

# Connecting an MGX 8220 AUSM–8T1/B to a 3620 Using IMA Trunks Sample Configuration

Document ID: 22203

---

## Introduction

### Prerequisites

- Requirements
- Components Used
- Conventions

### Configure

- Network Diagram
- 3620 Router
- MGX 8220 AUSM–8T1/B
- MC 3810
- MGX 8220 FRSM
- BPX 8600

### Show Commands

- MGX 8220 AUSM–8T1/B
- MC 3810
- MGX 8220 FRSM–8T1
- BPX 8600

### Related Information

---

## Introduction

This document provides configuration information for a service–interworking (SIW) connection over an inverse multiplexing for ATM (IMA) trunk group. The configuration for each device is created using the command line interface (CLI). The SIW connection establishes IP connectivity between a Cisco 3620 router ATM interface and a Cisco MC 3810 frame relay interface. The four T1 IMA trunk groups are established between the 3620 router T1 IMA and MGX 8220 AUSM–8T1/B service modules. The MGX 8220 is connected as a feeder shelf to the BPX 8600. The BPX 8600 provides the switching from the AUSM–8T1/B ATM connection to the FRSM–8T1 frame relay connection on the same MGX 8220. The MGX 8220 FRSM–8T1 service module provides the SIW conversion from ATM (aal5snap encapsulation) to frame relay (IETF encapsulation).

This document is intended to be used as an aid for configuring Cisco equipment, but is not a substitute for proper network design and planning with your Cisco Sales Engineer, Systems Engineer, or Account Manager.

## Prerequisites

### Requirements

There are no specific requirements for this document.

### Components Used

The information in this document is based on these software and hardware versions:

- 3620:

- ◆ Software – Cisco IOS® Software Release 12.1(1a)T1.
- ◆ Hardware – Cisco 3620 with 8–port T1 IMA network interface.
- **MC 3810**
  - ◆ Software – Cisco IOS Software Release 12.0(4)T.
  - ◆ Hardware – Cisco MC 3810 with T1 multi–flex trunk (MFT) interface.
- **MGX 8220**
  - ◆ Firmware – Cisco release 5.0.14 and the appropriate versions of service module hardware and firmware. Refer to the WAN Switching Software Center ( registered customers only) .
  - ◆ Hardware – Cisco AUSM model B service module is used for ATM Forum compliant IMA. Four T1 trunks are used to connect between the 8–port AUSM–8T1/B service module and the 8–port 3620 T1 IMA module. Both the AUSM–8T1/B and 3620 T1 IMA service modules use RJ48 connectors.
  - ◆ FRSM–8T1 service module uses RJ48 connectors.
- **BPX 8600**
  - ◆ Software – Cisco switch software release 9.1.18 and the appropriate versions of card hardware and firmware as specified in the Release Notes.
  - ◆ Hardware – The BPX 8600 is connected to the MGX 8220 feeder shelf using a BNI–T3 card set.

The information in this document was created from the devices in a specific lab environment. All of the devices used in this document started with a cleared (default) configuration. If your network is live, make sure that you understand the potential impact of any command.

## Conventions

For more information on document conventions, refer to the Cisco Technical Tips Conventions.

## Configure

In this section, you are presented with the information to configure the features described in this document.

**Note:** To find additional information on the commands used in this document, use the Command Lookup Tool ( registered customers only) .

## Network Diagram

This document uses this network setup:

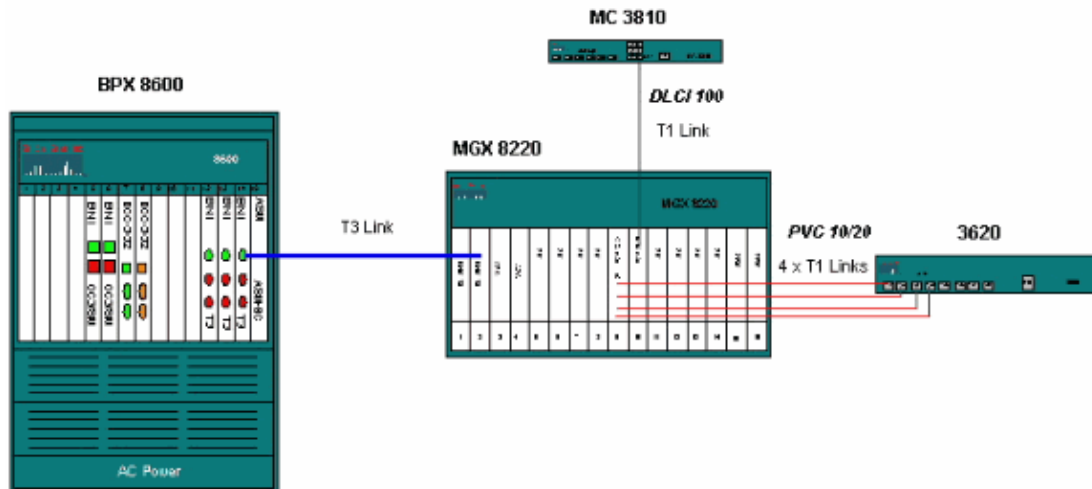

## 3620 Router

Configure ATM interfaces as an IMA group and assign IP address to the logical IMA interface. All **show** command output is in the Show Command section of this document. For additional **show** commands and troubleshooting information, refer to Troubleshooting ATM IMA Links on Cisco 2600 and 3600 Routers.

```
r3620(config)#interface atm0/0
r3620(config-if)#ima-group 1

!-1- Add the interface to IMA group 1.

r3620(config-if)#no shut
r3620(config-if)#int atm0/1
r3620(config-if)#ima-group 1

!--- Each interface must be added to IMA group 1.

r3620(config-if)#no shut
r3620(config)#int atm0/2
r3620(config-if)#ima-group 1
r3620(config-if)#no shut
r3620(config)#int atm0/3
r3620(config-if)#ima-group 1
r3620(config-if)#no shut
r3620(config-if)#int ATM0/IMA1.10 point-to-point

!--- Configure the IMA interface.

r3620(config-subif)#ip add 2.2.2.1 255.255.255.0
r3620(config-subif)#ima active-links-minimum 1
r3620(config-subif)#ima differential-delay-maximum 75
r3620(config-subif)#pvc IMA-VC 10/20
r3620(config-if-at)#protocol ip 10.1.1.2 broadcast
r3620(config-if-at)#encapsulation aal5snap
r3620(config-if-at)#vbr-nrt 512 384 128

!--- Set the connection type.
```

This output is the minimum number of active links required for the IMA group to be operational. The default value is 1.

```
ima active-links-minimum 1
```

This output is the maximum timing delay that can exist among the active links in the IMA group. The default value is 25 milliseconds (msec).

```
ima differential-delay-maximum 75
```

This output specifies a non-realtime variable bit-rate connection with a Peak Cell Rate (PCR) of 512 kbps, sustained cell rate (SCR) of 384 kbps, and Maximum Burst Size (MBS) of 128 cells.

```
vbr-nrt 512 384 128
```

Configuring traffic-shaping parameters for PCR, SCR, and MBS on the router is important to avoid data loss caused by discards on the switch. When traffic-shaping parameters are not configured on the router, the initial router burst of data may be transmitted at port speed. In this example with four physical T1s composing one IMA port, the port speed is high. If the switch is not configured to accept large initial bursts, data is discarded.

## MGX 8220 AUSM-8T1/B

Issue the StrataCom-level **dsptype** command to verify the IMA feature is enabled on the AUSM-8T1/B service module. If StrataCom-level access is not available, proceed with the configuration.

```
a1.1.10.AUSMB8.a > dsptype
Channelized: Off
Rate Control: On
IMA feature: On
```

If IMA feature is off or you are unable to add the IMA group, contact Cisco Technical Support (registered customers only) for assistance with enabling this feature.

Add the lines on the AUSM-8T1/B card that are included in the IMA group. The relationship between the AUSM-8T1/B and 3620 T1 IMA lines is shown here.

| Service Module | Physical Ports |
|----------------|----------------|
| 3620 T1 IMA    | 0, 1, 2, 3     |
| AUSM-8T1/B     | 1, 2, 3, 4     |

```
a1.1.10.AUSMB8.a > addln 1
a1.1.10.AUSMB8.a > addln 2
a1.1.10.AUSMB8.a > addln 3
a1.1.10.AUSMB8.a > addln 4
```

Check all the lines and clear any alarms before adding them into the IMA group. Using contiguous lines in an IMA group is recommended but not required. An IMA group can be composed of lines 1, 3, 4, and 5. Note that line framing and line coding for the T1s between the AUSM/B and 3620 must match. For IMA groups that span international boundaries, configure network clock sources before you add the lines.

```
a1.1.10.AUSMB8.a > dsplns
```

| Line | Conn Type | Type    | Status/Coding | Length   | XmtClock Source | Alarm | Stats Alarm |
|------|-----------|---------|---------------|----------|-----------------|-------|-------------|
| 14.1 | RJ-48     | dsx1ESF | Ena/dsx1B8ZS  | 0-131 ft | LocalTim        | No    | No          |
| 14.2 | RJ-48     | dsx1ESF | Ena/dsx1B8ZS  | 0-131 ft | LocalTim        | No    | No          |
| 14.3 | RJ-48     | dsx1ESF | Ena/dsx1B8ZS  | 0-131 ft | LocalTim        | No    | No          |
| 14.4 | RJ-48     | dsx1ESF | Ena/dsx1B8ZS  | 0-131 ft | LocalTim        | No    | No          |
| 14.5 | RJ-48     | dsx1ESF | Dis/dsx1B8ZS  | 0-131 ft | LocalTim        |       |             |



```

GroupBeta          : 2
GroupGamma         : 1

```

Type <CR> to continue, Q<CR> to stop:

```

GroupConfiguration : 1
IMAGrp Failure status : No Failure
Timing reference link : 3

```

Verify the AUSM-8T1/B IMA port payload scrambling configuration is the same as that of the 3620 interface. Payload scrambling was developed to ensure that ATM cell payload does not resemble cell header and is only locally significant. Specifically, each side of an ATM interface must have the same payload scrambling value, but all ATM interfaces in the network do not require the same configuration.

```
a1.1.10.AUSMB8.a > dspports
```

No ATM T1/E1 UNI ports currently active

```
List of IMA groups:
=====
```

| ImaGrp | PortType | Conf rate | Avail rate | Lines configured | Lines present | Tol Diff Delay(ms) | Port e |
|--------|----------|-----------|------------|------------------|---------------|--------------------|--------|
| 14.1   | UNI      | 14364     | 3591       | 1.2.3.4          | 1.2.3.4       | 275                | Active |

```
NextPortNumAvailable: 8
```

```
a1.1.10.AUSMB8.a > dspplpp 1
```

```

PhysicalPortNumber: 1
CellFraming: ATM
CellScramble: No Scramble
Plpp Loopback: No Loopback
Single-bit error correction: Disabled

```

Now add a VBR connection to the IMA port with VPI 10 and VCI 20.

```
a1.1.10.AUSMB8.a > addcon 200 0 1 10 20 2
```

| User Input    | Definition   |
|---------------|--|
| <b>addcon</b> | Add a connection to the current AUSM.  |
| <b>200</b>    | channel number Value that ranges from 16 to 1015.  |
| <b>0</b>      | Connection Type Connection Type : 0 – VCC , non zero – Local VP Id of the VPC (1 to 20(UNI)/100(STI)/340(NNI)) |
| <b>1</b>      | port number Values that range from 1 to 8.   |
| <b>10</b>     | Channel VPI Virtual Path Identifier: 0 – 255. <i>Must match VPI on 3620.</i>                                   |
| <b>20</b>     | Channel VCI Virtual Channel Identifier: 0 – 65535 for VCC, * for VPC. <i>Must match VCI on 3620.</i>           |
| <b>2</b>      | Service Type Service Type: 1 – CBR, 2 – VBR, 3 –   |

```
ABR, 4 – UBR. Should match connection type on
3620.
```

Configure the VBR connection values to reflect those of the 3620. The connection values are not optimized and are used for example only.

```
a1.1.10.AUSMB8.a > cnfupcvbr

ERR : incorrect number of parameters (not enough)
Syntax : cnfupcvbr "chan_num enable pcr[0+1] cdvt[0+1] scr scr_police
             mbs IngPcUtil EgSrvRate EgPcUtil clp_tag "

Channel # -- Channel Number : 16 - 1015
Enable/Disable -- UPC : 1 - Disable, 2 - Enable
PeakCellRate -- PCR [0+1]: 10-PortRate(T1-3622,E1-4528,clearE1-4830),
             For IMA,T1-3591,E1-4490,clrE1-4789, multiply rate by #links
CDVT[0+1] -- Cell Delay Variation [0+1]: 1 - 250000 micro_secs
SCR -- Sustained Cell Rate:10-PortRate(T1-3622,E1-4528,clearE1-4830),
             For IMA,T1-3591,E1-4490,clrE1-4789, multiply rate by #links
SCR Policing -- 1 - CLP[0] Cells, 2 - CLP[0+1] Cells, 3 - No SCR Policing
Maximum Burst -- 1 - 5000 cells
IngPcUtil -- Ingress percentage util: 1 to 127. 0 for default
EgSrvRate -- Egress service rate:1-PortRate(T1-3622,E1-4528,clearE1-48,
             For IMA,T1-3591,E1-4490,clrE1-4789, multiply rate by #links
EgPcUtil -- Egress percentage util: 1 to 127. 0 for default
Clp Tagging -- CLP TAG Enable : 1 - Disable, 2 - Enable

a1.1.10.AUSMB8.a > cnfupcvbr 200 2 3622 25000 2048 1 1000 100 2633 100 2
```

## MC 3810

```
r3a#conf t
r3a(config)#cont t1 0
r3a(config-controller)#framing esf
r3a(config-controller)#linecode b8zs
r3a(config-controller)#channel-group 0 timeslots 1-24 speed 64
r3a(config-controller)#no shut
r3a(config-controller)#int s0:0
r3a(config-if)#ip address 2.2.2.2 255.255.255.0
r3a(config-if)#encapsulation frame-relay IETF
r3a(config-if)#frame-relay map ip 2.2.2.1 100 broadcast

!-- associate the DLCI to the IP address

r3a(config-if)#no shut
```

## MGX 8220 FRSM

Verify the existing lines.

```
a1.1.9.FRSM.a > dsplns

Line Conn Type Status/Coding Length XmtClock Alarm Stats
Type                                     Source Alarm
-----
6.1 DB-15 dsx1ESF Dis/dsx1B8ZS 0-110 ft LocalTim
6.2 DB-15 dsx1ESF Dis/dsx1B8ZS 0-110 ft LocalTim
6.3 DB-15 dsx1ESF Dis/dsx1B8ZS 0-110 ft LocalTim
6.4 DB-15 dsx1ESF Dis/dsx1B8ZS 0-110 ft LocalTim

LineNumOfValidEntries: 4
```

Enable the line connected to the MC 3810 router. Note that line framing and line coding for the T1 between the FRSM and MC 3810 must match.

```
a1.1.9.FRSM.a > addln 1
```

Enable the logical port and configure for frame-relay service.

```
a1.1.9.FRSM.a > addport 1 1 2 1 24 1
```

| User Input     | Definition  |
|----------------|---|
| <b>addport</b> | Add a Port  |
| <b>1</b>       | port number Values that range from 1 to 192 are accepted for T1 and 1–2481. |
| <b>1</b>       | line number Value that ranges from 1 to 8.                                  |
| <b>2</b>       | DS0 speed; for 56 K, 2 for 64 K   |
| <b>1</b>       | beginning slot Beginning time slot in 1 base.                               |
| <b>24</b>      | number of slot Number of DS0 time slots assigned to.                        |
| <b>1</b>       | port type Values 1–3, 1=frame relay, 2=FUNI mode-1a, 3=frForward            |

Configure the logical port to use local management interface (LMI) signaling. This example uses StrataLMI with asynchronous updates enabled and enhanced LMI disabled.

```
a1.1.9.FRSM.a > cnfport 1 S 2 n
```

| User Input     | Definition  |
|----------------|---|
| <b>cnfport</b> | Configure Port  |
| <b>1</b>       | port number Values that range from 1 to 192 are accepted for T1 and 1 to 2481 for E1.   |
| <b>S</b>       | LMI signaling (N)one (S)trataLMI au-AnnexAUNI du-AnnexDUNI an-AnnexANNI dn-AnnexDNNI. <i>Must match LMI on MC 3810.</i>           |
| <b>2</b>       | asyn UPD/UFS (UPD = Update Status, UFS = Unsolicited Full Status) (n or 1) = both dis, (y or 2) = UPD en, 3 = UFS en, 4 = both en |
| <b>n</b>       | Enhanced LMI (N or n) disable (Y or y) enable   |

Display and verify the configuration of the logical port.

```
a1.1.9.FRSM.a > dsports
```

```

Port      Ena/Speed   EQServ  SignalType  T391  T392  N391  N392  N393  Type      I
-----
6.1.1    Mod/1536 Kbps  1      StrataLMI   10    15    6     3     4    frameRel

```

```

Number of ports:          1

PortDs0UsedLine1:       0x00ffffff
PortDs0UsedLine2:       0x00000000
PortDs0UsedLine3:       0x00000000
PortDs0UsedLine4:       0x00000000
PortNumNextAvailable:   7

```

Add the connection and enable service internetworking translation. Note that connection values are not optimized and are used for example only.

```
a1.1.9.FRSM.a > addchan 100 1 100 1536000 3
```

| User Input | Definition  |
|------------|---|
| addchan    | Add a channel to the current FRSM   |
| 100        | channel number Value that ranges from 16 to 1015.                                     |
| 1          | port number Values that range from 1 to 192 are accepted for T1 and 1 to 2481 for E1. |
| 100        | DLCI number Value that ranges from 0 to 1023.<br><i>Must match DLCI on MC 3810.</i>   |
| 1536000    | committed rate --- 0-1536000 bps for T1;<br>0-2048000 bps for E1.                     |
| 3          | chan type Values 1 to 5, 1=NIW 2=SIW-transparent<br>3=SIW-xlation 4=FUNI 5=frForward  |

## BPX 8600

Add the MGX 8220 as a feeder shelf to the BPX 8600 switch. Issue the **uptrk** command to activate the T3 trunk.

```

b3          TRM   SuperUser      BPX 8600  9.1.18   Oct. 6 2000  10:48 GMT
TRK        Type   Current Line Alarm Status   Other End
  2.1      T3     Clear - OK                    -

```

Last Command: **uptrk 2.1**

Next Command:

Check the trunk and clear any alarms. Once the trunk is clear of alarms, issue the **addshelf** command.

```

b3          TRM   SuperUser      BPX 8600  9.1.18   Oct. 6 2000  10:54 GMT
          BPX 8600 Interface Shelf Information

Trunk      Name      Type          Part Id   Ctrl Id   Alarm
  2.1      a1         AXIS          -         -         MIN

```

Last Command: **addshelf 2.1 A**

**Shelf has been added**

Next Command:

Add the connection on the BPX 8600 switch by issuing the **addcon** command. The connection values are not optimized for frame relay to ATM service interworking and are used for example only. For more information about ATM connection configuration and troubleshooting, refer to ATM Connection Configuration and Troubleshooting for the Cisco BPX 8600 Series Switch and Troubleshooting ATM PVC Problems.

```
addcon 2.1.9.100 b3 2.1.10.200 atfr 2000/2000 * 25000/25000 1000/1000 * * * * *
```

| User Input         | Definition  |
|--------------------|---|
| <b>addcon</b>      | Add a connection.   |
| <b>2.1.9.100</b>   | connection number<br><feeder_trunk_slot.feeder_trunk_port.FRSM_slot.FRSM_channel>   |
| <b>b3</b>          | remote node name Repeat the name for locally-switched connections.  |
| <b>2.1.10.200</b>  | connection number<br><feeder_trunk_slot.feeder_trunk_port.AUSM_slot.AUSM_channel>   |
| <b>atfr</b>        | connection type ATM (at) to frame relay (fr)  |
| <b>2000/2000</b>   | PCR (0 + 1) [50/50] Peak Cell Rate. Equivalent to frame relay peak information rate (PIR) for cell loss priority (CLP) 0 and CLP=1 traffic. Default value is 50 in both transmit and receive directions.                            |
| <b>100/100</b>     | % Util [100/100] Percent utilization. Default value is 100 in both transmit and receive directions.   |
| <b>25000/25000</b> | CDVT (0 + 1) [250000/250000] Cell Delay Variation Tolerance. Default value is 250000 in both transmit and receive directions.   |
| <b>1000/1000</b>   | SCR [50/50] Sustainable Cell Rate. Equivalent to frame relay committed information rate (CIR). Default value is 50 in both transmit and receive directions.   |
| <b>1000/1000</b>   | MBS [1000/1000] Maximum Burst Size. Equivalent to frame relay excess burst size (Be). Default value is 1000 in both transmit and receive directions.  |
| <b>3</b>           | Policing [3] The algorithm used to determine conformance to traffic contract. Default value is 3 for ATM Forum Traffic Management Specification Version 4.0 VBR.3.  |
| <b>1280/1280</b>   | VC Qdepth [1280/1280] Virtual Connection Queue Depth. Default value is 1280 in both transmit and receive directions.  |
| <b>35/35</b>       | EFCI [35/35] Explicit Forward Congestion Indication. Equivalent to frame relay forward explicit congestion notification (FECN). Configured per port queue for the BXM. Default value is 35 in both transmit and receive directions. |
| <b>1/1</b>         | IBS [1/1] Initial Burst Size. Equivalent to frame relay Cmax. Default value is 1 in both transmit and receive directions.   |

## Show Commands

Certain **show** commands are supported by the Output Interpreter Tool (registered customers only), which allows you to view an analysis of **show** command output.

Command summary:

- **show version**
- **show run**
- **show atm pvc**
- **show interface atm0/0**
- **show atm interface atm0/0**
- **show interface ATM0/IMA1**
- **show interface ATM0/IMA1.10**
- **show ima interface atm0/0**
- **show ima interface atm0/ima1 detail**
- **show cont atm0/ima1**

```
r3620#ping 2.2.2.2
```

```
Type escape sequence to abort.
```

```
Sending 5, 100-byte ICMP Echos to 2.2.2.2, timeout is 2 seconds:
```

```
!!!!
```

```
Success rate is 100 percent (5/5), round-trip min/avg/max = 104/136/148 ms
```

```
r3620#show version
```

```
Cisco Internetwork Operating System Software
```

```
IOS (tm) 3600 Software (C3620-JS-M), Version 12.1(1a)T1, RELEASE SOFTWARE (fc1)
```

```
Copyright (c) 1986-2000 by cisco Systems, Inc.
```

```
Compiled Mon 03-Apr-00 11:10 by ccai
```

```
Image text-base: 0x600088F0, data-base: 0x612A6000
```

```
ROM: System Bootstrap, Version 11.1(20)AA2, EARLY DEPLOYMENT RELEASE SOFTWARE ( )
```

```
r3620 uptime is 4 hours, 27 minutes
```

```
System returned to ROM by power-on
```

```
System image file is "flash:c3620-js-mz.121-1a.T1"
```

```
cisco 3620 (R4700) processor (revision 0x81) with 57344K/8192K bytes of memory.
```

```
Processor board ID 10707918
```

```
R4700 CPU at 80Mhz, Implementation 33, Rev 1.0
```

```
Bridging software.
```

```
X.25 software, Version 3.0.0.
```

```
SuperLAT software (copyright 1990 by Meridian Technology Corp).
```

```
TN3270 Emulation software.
```

```
16 ATM network interface(s)
```

```
DRAM configuration is 32 bits wide with parity disabled.
```

```
29K bytes of non-volatile configuration memory.
```

```
16384K bytes of processor board System flash (Read/Write)
```

```
Configuration register is 0x2102
```

```
r3620#show run
```

```
Building configuration...
```

```
Current configuration:
```

```
!
```

```
version 12.1
```

```
service timestamps debug uptime
```

```
service timestamps log uptime
```

```
service password-encryption
```

```
!
```

```
hostname r3620
```

```
!
```

```
!
```

```
!
```

```
!
```

```
!  
!  
ip subnet-zero  
no ip domain-lookup  
!  
cns event-service server  
!  
!  
!  
interface ATM0/0  
no ip address  
no atm ilmi-keepalive  
ima-group 1  
no scrambling-payload  
!  
interface ATM0/1  
no ip address  
no atm ilmi-keepalive  
ima-group 1  
no scrambling-payload  
!  
interface ATM0/2  
no ip address  
no atm ilmi-keepalive  
ima-group 1  
no scrambling-payload  
!  
interface ATM0/3  
no ip address  
no atm ilmi-keepalive  
ima-group 1  
no scrambling-payload  
!  
interface ATM0/4  
no ip address  
shutdown  
no atm ilmi-keepalive  
no scrambling-payload  
!  
interface ATM0/5  
no ip address  
shutdown  
no atm ilmi-keepalive  
no scrambling-payload  
!  
interface ATM0/6  
no ip address  
shutdown  
no atm ilmi-keepalive  
no scrambling-payload  
!  
interface ATM0/7  
no ip address  
shutdown  
no atm ilmi-keepalive  
no scrambling-payload  
!  
interface ATM0/IMA1  
no ip address  
no atm ilmi-keepalive  
!  
interface ATM0/IMA1.10 point-to-point  
ip address 2.2.2.1 255.255.255.0  
pvc 10/20  
protocol ip 2.2.2.2 broadcast
```

```

    encapsulation aal5snap
    !
    !
interface ATM1/0
    no ip address
    shutdown
    no atm ilmi-keepalive
    no scrambling-payload
    !
interface ATM1/1
    no ip address
    shutdown
    no atm ilmi-keepalive
    no scrambling-payload
    !
interface ATM1/2
    no ip address
    shutdown
    no atm ilmi-keepalive
    no scrambling-payload
    !
interface ATM1/3
    no ip address
    shutdown
    no atm ilmi-keepalive
    no scrambling-payload
    !
interface ATM1/4
    no ip address
    shutdown
    no atm ilmi-keepalive
    no scrambling-payload
    !
interface ATM1/5
    shutdown
    no atm ilmi-keepalive
    no scrambling-payload
    !
interface ATM1/6
    no ip address
    shutdown
    no atm ilmi-keepalive
    no scrambling-payload
    !
interface ATM1/7
    no ip address
    shutdown
    no atm ilmi-keepalive
    no scrambling-payload
    !
ip classless
no ip http server
    !
    !
    !
line con 0
    transport input none
line aux 0
line vty 0 4
    login
    !
end

```

r3620#show atm pvc

| Interface | VCD /<br>Name | VPI | VCI | Type | Encaps | SC | Peak<br>Kbps | Avg/Min<br>Kbps | Burst<br>Cells | Sts |
|-----------|---------------|-----|-----|------|--------|----|--------------|-----------------|----------------|-----|
|-----------|---------------|-----|-----|------|--------|----|--------------|-----------------|----------------|-----|

0/IMA1.10 1 10 20 PVC SNAP UBR 1500 UP

r3620#**show interface atm0/0**

ATM0/0 is up, line protocol is up  
Hardware is ATM T1  
MTU 4470 bytes, sub MTU 4470, BW 1500 Kbit, DLY 20000 usec,  
reliability 0/255, txload 1/255, rxload 1/255  
Encapsulation ATM, loopback not set  
Keepalive not supported  
Encapsulation(s): AAL5  
256 maximum active VCs, 0 current VCCs  
VC idle disconnect time: 300 seconds  
Last input never, output never, output hang never  
Last clearing of "show interface" counters never  
Input queue: 0/75/0/0 (size/max/drops/flushes); Total output drops: 0  
Queueing strategy: Per VC Queueing  
5 minute input rate 0 bits/sec, 0 packets/sec  
5 minute output rate 0 bits/sec, 0 packets/sec  
0 packets input, 0 bytes, 0 no buffer  
Received 0 broadcasts, 0 runts, 0 giants, 0 throttles  
0 input errors, 0 CRC, 0 frame, 0 overrun, 0 ignored, 0 abort  
0 packets output, 0 bytes, 0 underruns  
0 output errors, 0 collisions, 1 interface resets  
0 output buffer failures, 0 output buffers swapped out

r3620#**show atm interface atm0/0**

Interface ATM0/0:  
AAL enabled: AAL5 , Maximum VCs: 256, Current VCCs: 0

Maximum Transmit Channels: 0  
Max. Datagram Size: 4496  
PLIM Type: DS1, Framing is T1 ESF, TX clocking: LINE  
Cell-payload scrambling: OFF  
0 input, 0 output, 0 IN fast, 0 OUT fast, 0 out drop  
Avail bw = 1500  
Config. is ACTIVE

r3620#**show interface ATM0/IMA1**

ATM0/IMA1 is up, line protocol is up  
Hardware is ATM IMA  
MTU 4470 bytes, sub MTU 4470, BW 6000 Kbit, DLY 20000 usec,  
reliability 236/255, txload 1/255, rxload 1/255  
Encapsulation ATM, loopback not set  
Keepalive not supported  
Encapsulation(s): AAL5  
256 maximum active VCs, 1 current VCCs  
VC idle disconnect time: 300 seconds  
Last input 00:04:32, output 00:04:32, output hang never  
Last clearing of "show interface" counters never  
Input queue: 0/75/0/0 (size/max/drops/flushes); Total output drops: 0  
Queueing strategy: Per VC Queueing  
5 minute input rate 0 bits/sec, 0 packets/sec  
5 minute output rate 0 bits/sec, 0 packets/sec  
41 packets input, 4548 bytes, 0 no buffer  
Received 0 broadcasts, 0 runts, 0 giants, 0 throttles  
0 input errors, 0 CRC, 0 frame, 0 overrun, 0 ignored, 0 abort  
493 packets output, 30688 bytes, 0 underruns  
0 output errors, 0 collisions, 1 interface resets  
0 output buffer failures, 0 output buffers swapped out

r3620#**show interface ATM0/IMA1.10**

ATM0/IMA1.10 is up, line protocol is up  
Hardware is ATM IMA  
Internet address is 2.2.2.1/24  
MTU 4470 bytes, BW 6000 Kbit, DLY 20000 usec,

```
reliability 236/255, txload 1/255, rxload 1/255
Encapsulation ATM
41 packets input, 4548 bytes
493 packets output, 30688 bytes
438 OAM cells input, 438 OAM cells output
AAL5 CRC errors : 0
AAL5 SAR Timeouts : 0
AAL5 Oversized SDUs : 0
```

**r3620#show ima interface atm0/0**

```
Interface ATM0/0 is up
    ifIndex 1, Group Index 1, Row Status is active
    Tx/Rx Lid 0/0, relative delay 0ms
    Ne Tx/Rx state active/active
    Fe Tx/Rx state active/active
    Ne Rx failure status is noFailure
    Fe Rx failure status is noFailure
    Rx test pattern 0x43, test procedure disabled
IMA Link Current Counters (time elapsed 756 seconds):
    0 Ima Violations, 0 Oif Anomalies
    0 Ne Severely Err Secs, 0 Fe Severely Err Secs
    0 Ne Unavail Secs, 0 Fe Unavail Secs
    0 Ne Tx Unusable Secs, 0 Ne Rx Unusable Secs
    0 Fe Tx Unusable Secs, 0 Fe Rx Unusable Secs
    0 Ne Tx Failures, 0 Ne Rx Failures
    0 Fe Tx Failures, 0 Fe Rx Failures
IMA Link Total Counters (last 7 15 minute intervals):
    1 Ima Violations, 3 Oif Anomalies
    12 Ne Severely Err Secs, 0 Fe Severely Err Secs
    3600 Ne Unavail Secs, 0 Fe Unavail Secs
    1802 Ne Tx Unusable Secs, 3602 Ne Rx Unusable Secs
    2 Fe Tx Unusable Secs, 0 Fe Rx Unusable Secs
    0 Ne Tx Failures, 8 Ne Rx Failures
    0 Fe Tx Failures, 0 Fe Rx Failures
```

**r3620#show ima interface atm0/ima1 detail**

```
Interface ATM0/IMA1 is up
    Group index is 1
    Ne state is operational, failure status is noFailure
    Active links bitmap 0xF
IMA Group Current Configuration:
    Tx/Rx configured links bitmap 0xF/0xF
    Tx/Rx minimum required links 1/1
    Maximum allowed diff delay is 25ms, Tx frame length 128
    Ne Tx clock mode CTC, configured timing reference link ATM0/0
    Test pattern procedure is disabled
Detailed group Information:
    Tx/Rx Ima_id 0x1/0x0, symmetry symmetricOperation
    Number of Tx/Rx configured links 4/4
    Number of Tx/Rx active links 4/4
    Fe Tx clock mode ctc, Rx frame length 128
    Tx/Rx timing reference link 0/0
    Maximum observed diff delay 0ms, least delayed link 2
    Running seconds 9273
    GTSM last changed 03:49:15 UTC Mon Mar 1 1993
IMA Group Current Counters (time elapsed 870 seconds):
    0 Ne Failures, 0 Fe Failures, 0 Unavail Secs
IMA Group Interval(1) Counters:
    0 Ne Failures, 0 Fe Failures, 0 Unavail Secs
IMA Group Interval(2) Counters:
    0 Ne Failures, 0 Fe Failures, 0 Unavail Secs
IMA Group Interval(3) Counters:
    0 Ne Failures, 0 Fe Failures, 0 Unavail Secs
IMA Group Interval(4) Counters:
    1 Ne Failures, 1 Fe Failures, 900 Unavail Secs
IMA Group Interval(5) Counters:
```

```
0 Ne Failures, 0 Fe Failures, 900 Unavail Secs
IMA Group Interval(6) Counters:
0 Ne Failures, 0 Fe Failures, 900 Unavail Secs
IMA Group Interval(7) Counters:
1 Ne Failures, 0 Fe Failures, 900 Unavail Secs
IMA Group Total Counters (last 8 15 minute intervals):
3 Ne Failures, 2 Fe Failures, 3604 Unavail Secs
Detailed IMA link Information:
```

```
Interface ATM0/0 is up
  ifIndex 1, Group Index 1, Row Status is active
  Tx/Rx Lid 0/0, relative delay 0ms
  Ne Tx/Rx state active/active
  Fe Tx/Rx state active/active
  Ne Rx failure status is noFailure
  Fe Rx failure status is noFailure
  Rx test pattern 0x43, test procedure disabled
IMA Link Current Counters (time elapsed 61 seconds):
0 Ima Violations, 0 Oif Anomalies
0 Ne Severely Err Secs, 0 Fe Severely Err Secs
0 Ne Unavail Secs, 0 Fe Unavail Secs
0 Ne Tx Unusable Secs, 0 Ne Rx Unusable Secs
0 Fe Tx Unusable Secs, 0 Fe Rx Unusable Secs
0 Ne Tx Failures, 0 Ne Rx Failures
0 Fe Tx Failures, 0 Fe Rx Failures
IMA Link Interval(1) Counters:
0 Ima Violations, 0 Oif Anomalies
0 Ne Severely Err Secs, 0 Fe Severely Err Secs
0 Ne Unavail Secs, 0 Fe Unavail Secs
0 Ne Tx Unusable Secs, 0 Ne Rx Unusable Secs
0 Fe Tx Unusable Secs, 0 Fe Rx Unusable Secs
0 Ne Tx Failures, 0 Ne Rx Failures
0 Fe Tx Failures, 0 Fe Rx Failures
IMA Link Interval(2) Counters:
0 Ima Violations, 0 Oif Anomalies
0 Ne Severely Err Secs, 0 Fe Severely Err Secs
0 Ne Unavail Secs, 0 Fe Unavail Secs
0 Ne Tx Unusable Secs, 0 Ne Rx Unusable Secs
0 Fe Tx Unusable Secs, 0 Fe Rx Unusable Secs
0 Ne Tx Failures, 0 Ne Rx Failures
0 Fe Tx Failures, 0 Fe Rx Failures
IMA Link Interval(3) Counters:
0 Ima Violations, 0 Oif Anomalies
0 Ne Severely Err Secs, 0 Fe Severely Err Secs
0 Ne Unavail Secs, 0 Fe Unavail Secs
0 Ne Tx Unusable Secs, 0 Ne Rx Unusable Secs
0 Fe Tx Unusable Secs, 0 Fe Rx Unusable Secs
0 Ne Tx Failures, 0 Ne Rx Failures
0 Fe Tx Failures, 0 Fe Rx Failures
```

```
r3620#show cont atm0/ima1
```

```
Interface ATM0/IMA1 is up
  Hardware is ATM IMA
LANE client MAC address is 0050.7305.e681
  hwidb=0x62384A14, ds=0x61D6D2E0
  slot 0, unit 1, subunit 1
  rs8234 base 0x3C000000, slave base 0x3C000000
  rs8234 ds 0x61D6D2E0
  SBDs - avail 2048, guaranteed 1, unguaranteed 2047, starved 0
  Seg VCC table 3C00B800, Shadow Seg VCC Table 61D89928, VCD Table 61D9F954
  Schedule table 3C016800, Shadow Schedule table 61DA5980, Size C7E
  RSM VCC Table 3C03EA80, Shadow RSM VCC Table 61DABC80
  VPI Index Table 3C03C000, VCI Index Table 3C03E680
  Bucket2 Table 3C026200, Shadow Bucket2 Table 61DA8BA4
  MCR Limit Table 3C026600, Shadow MCR Table 61DAA7D0
  ABR template 3C026800, Shadow template 61A738E0
```

```

RM Cell RS Queue 3C03C680
Queue          TXQ Addr  Pos  StQ Addr  Pos
0  UBR CHN0    3C038800  0    039184A0  0
1  UBR CHN1    3C038C00  0    03918CA0  0
2  UBR CHN2    3C039000  0    039194A0  0

3  UBR CHN3    3C039400  237  03919CA0  237
4  VBR/ABR CHN0 3C039800  0    0391A4A0  0
5  VBR/ABR CHN1 3C039C00  0    0391ACA0  0
6  VBR/ABR CHN2 3C03A000  0    0391B4A0  0
7  VBR/ABR CHN3 3C03A400  0    0391BCA0  0
8  VBR-RT CHN0  3C03A800  0    0391C4A0  0
9  VBR-RT CHN1  3C03AC00  0    0391CCA0  0
10 VBR-RT CHN2  3C03B000  0    0391D4A0  0
11 VBR-RT CHN3  3C03B400  0    0391DCA0  0
12 SIG          3C03B800  0    0391E4A0  0
13 VPD          3C03BC00  0    0391ECA0  0

```

```

Queue          FBQ Addr  Pos  RSQ Addr  Pos
0  OAM          3C0FEA80  181  0391F560  182
1  UBR CHN0    3C0FFA80  0    03920560  0
2  UBR CHN1    3C100A80  0    03921560  0
3  UBR CHN2    3C101A80  0    03922560  0
4  UBR CHN3    3C102A80  40   03923560  41
5  VBR/ABR CHN0 3C103A80  0    03924560  0
6  VBR/ABR CHN1 3C104A80  0    03925560  0
7  VBR/ABR CHN2 3C105A80  0    03926560  0
8  VBR/ABR CHN3 3C106A80  0    03927560  0
9  VBR-RT CHN0  3C107A80  0    03928560  0
10 VBR-RT CHN1  3C108A80  0    03929560  0
11 VBR-RT CHN2  3C109A80  0    0392A560  0
12 VBR-RT CHN3  3C10AA80  0    0392B560  0
13 SIG          3C10BA80  0    0392C560  0

```

SAR Scheduling channels: 3 3 3 3 -1 -1 -1 -1

ATM channel number is 3

link members are 0xF, active links are 0xF

Group status is noFailure, 4 links configured,

Group Info: Configured links bitmap 0xF, Active links bitmap 0xF,

Tx/Rx IMA\_id 0x1/0x0,

NE Group status is operational,

frame length 0x80, Max Diff Delay 0,

1 min links, clock mode ctc, symmetry symmetricOperation, trl 0,

Group Failure status is noFailure.

Test pattern procedure is disabled

SAR counter totals across all links and groups:

603 cells output, 0 cells stripped

560 cells input, 17573739 cells discarded, 0 AAL5 frames discarded

0 pci bus err, 0 dma fifo full err, 0 rsm parity err

0 rsm syn err, 0 rsm/seg q full err, 0 rsm overflow err

0 hs q full err, 0 no free buff q err, 0 seg underflow err

0 host seg stat q full err

## MGX 8220 AUSM-8T1/B

Command summary:

- version
- dspfeature
- dsplns
- dspln
- dsports
- dspimagrp
- dspimainfo

- **dspplpp**
- **dspimagrpcnt**
- **dspimalncnt**
- **dspimaln**
- **dspchans**
- **tstcon**
- **dspchan**

a1.1.10.AUSMB8.a > **version**

```

***** Cisco Systems, Inc. AXIS AUSM-8T1/E1 Card *****
Firmware Version      = 5.0.12
Backup Boot version   = AU8_BT_1.0.02
AUSM8p Xilinx file   = ausm8pXilinx.h
VxWorks (for Cisco Systems, Inc.) version 5.1.1-R3000.
Kernel: WIND version 2.4.
Made on Wed Jun 21 18:24:45 PDT 2000.
Boot line:

```

a1.1.10.AUSMB8.a > **dspfeature**

```

Channelized: Off
Rate Control: On
IMA feature: On

```

a1.1.10.AUSMB8.a > **dsplns**

| Line | Conn Type | Type    | Status/Coding | Length   | XmtClock Source | Alarm | Stats Alarm |
|------|-----------|---------|---------------|----------|-----------------|-------|-------------|
| 10.1 | RJ-48     | dsx1ESF | Ena/dsx1B8ZS  | 0-131 ft | LocalTim        | No    | No          |
| 10.2 | RJ-48     | dsx1ESF | Ena/dsx1B8ZS  | 0-131 ft | LocalTim        | No    | No          |
| 10.3 | RJ-48     | dsx1ESF | Ena/dsx1B8ZS  | 0-131 ft | LocalTim        | No    | No          |
| 10.4 | RJ-48     | dsx1ESF | Ena/dsx1B8ZS  | 0-131 ft | LocalTim        | No    | No          |
| 10.5 | RJ-48     | dsx1ESF | Dis/dsx1B8ZS  | 0-131 ft | LocalTim        |       |             |
| 10.6 | RJ-48     | dsx1ESF | Dis/dsx1B8ZS  | 0-131 ft | LocalTim        |       |             |
| 10.7 | RJ-48     | dsx1ESF | Dis/dsx1B8ZS  | 0-131 ft | LocalTim        |       |             |
| 10.8 | RJ-48     | dsx1ESF | Dis/dsx1B8ZS  | 0-131 ft | LocalTim        |       |             |

LineNumOfValidEntries: 8

a1.1.10.AUSMB8.a > **dspln 1**

```

LineNum: 1
LineConnectorType: RJ-48
LineType: dsx1ESF
LineEnable: Enabled
LineCoding: dsx1B8ZS
LineLength: 0-131 ft
LineXmtClockSource: LocalTiming
LineLoopbackCommand: NoLoop
LineSendCode: NoCode
LineUsedTimeslotsBitMap: 0xffffffff
LineLoopbackCodeDetection: codeDetectDisabled
LineBERTEnable: Disable

```

LineNumOfValidEntries: 8

a1.1.10.AUSMB8.a > **dsports**

No ATM T1/E1 UNI ports currently active

```

List of IMA groups:
=====

```

| ImaGrp | PortType | Conf rate | Avail rate | Lines configured | Lines present | Tol Diff Delay(ms) | Port e  |
|--------|----------|-----------|------------|------------------|---------------|--------------------|---------|
| 10.1   | UNI      | 14364     | 14364      | 1.2.3.4          | 1.2.3.4       | 275                | B/w chd |

NextPortNumAvailable: 8

a1.1.10.AUSMB8.a > **dspimagrp 1**

```

IMA Group number           : 1
Port type                  : UNI
Lines configured           : 1.2.3.4
Enable                     : Enabled
IMA Port state             : B/w changed
IMA Group Ne state        : operational
PortSpeed (cells/sec)     : 14364
GroupTxAvailCellRate (cells/sec) : 14364
ImaGroupTxFrameLength(cells) : 128
LcpDelayTolerance (IMA frames) : 1
ReadPtrWrPtrDiff (cells)   : 4
Minimum number of links    : 1
MaxTolerableDiffDelay (msec) : 275
Lines Present              : 1.2.3.4
Observed Diff delay (msec) : 0
Clock Mode                 : CTC
GroupAlpha                 : 2
GroupBeta                  : 2
GroupGamma                 : 1
GroupConfiguration        : 1
IMAGrp Failure status     : No Failure
Timing reference link     : 1
ImaGroupTxImaId           : 0x0
ExpectedGroupRxImaId      : 0x1

```

a1.1.10.AUSMB8.a > **dspimainfo**

| Link | Group | NeTx State | NeRx State | FeTx State | FeRx State | TxLID | RxID |
|------|-------|------------|------------|------------|------------|-------|------|
| 1    | 1     | Active     | Active     | Active     | Active     | 0     | 0    |
| 2    | 1     | Active     | Active     | Active     | Active     | 1     | 1    |
| 3    | 1     | Active     | Active     | Active     | Active     | 2     | 2    |
| 4    | 1     | Active     | Active     | Active     | Active     | 3     | 3    |

a1.1.10.AUSMB8.a > **dspplpp 1**

```

PhysicalPortNumber: 1
CellFraming: ATM
CellScramble: No Scramble
Plpp Loopback: No Loopback
Single-bit error correction: Disabled

```

a1.1.10.AUSMB8.a > **dspimagrpcnt 1**

```

IMA Group number: 1
Ne Number of failures : 0

```

a1.1.10.AUSMB8.a > **dspimalncnt 1 1**

```

IMA group number : 1
Line number : 1
Icp Cells Received : 140041
Icp Errored Cells Recvd : 10
Ima Violations Count : 10

```

```

    Ima OIF anomalies           : 0
    Ima Ne Severely Errored Seconds : 0
    Ima Fe Severely Errored Seconds : 1
    Ima Ne Unavailable Seconds     : 0
    Ima Fe Unavailable Seconds     : 0
    Ima NeTx Unusable Seconds     : 1336
    Ima NeRx Unusable Seconds     : 1335
    Ima FeTx Unusable Seconds     : 1
    Ima FeRx Unusable Seconds     : 1
    Ima FeTx Num. Failues        : 0
    Ima FeRx Num. Failures       : 0
    # HEC errored cells          : 0
    # HEC errored seconds        : 0
    # Severely HEC errored seconds : 0

```

a1.1.10.AUSMB8.a > **dspimaln 1 1**

```

    IMA Group number           : 1
    Link number                 : 1
    ImaLink TxLID              : 0x0
    ImaLink RxLID              : 0x0
    LinkNeRxState              : Active
    LinkNeTxState              : Active
    LinkNeRxFailureStatus      : No Failure
    LinkFeRxState              : Active
    LinkFeTxState              : Active
    LinkFeRxFailureStatus      : No Failure
    LinkRelDelay               : 0
    LinkRxTestPattern          : 255
    Ne Link Tx Num Failures     : 0
    Ne Link Rx Num Failures     : 0

```

a1.1.10.AUSMB8.a > **dspchans**

| Chan | Port    | VPI | VCI | ConnType | Service Type | PCR[0+1] | Q-Depth | State  |
|------|---------|-----|-----|----------|--------------|----------|---------|--------|
| 200  | 1.10.20 |     |     | VCC      | VBR          | 10       | 1000    | Active |

```

    ChanNumNextAvailable      : 18
    Local VpId NextAvailable  : 16

```

a1.1.10.AUSMB8.a > **tstcon 200**

tstcon in progress

Test passed.

r3620#**ping 2.2.2.2**

Type escape sequence to abort.

Sending 5, 100-byte ICMP Echos to 2.2.2.2, timeout is 2 seconds:

.....

Success rate is 0 percent (0/5)

a1.1.10.AUSMB8.a > **dspchan 200**

```

    ChanNum:                200
    RowStatus:              Mod
    ConnectionType:         VCC
    ServiceType:            VBR
    PortNum:                1
    VPI:                    10
    VCI (For VCC):         20
    Local VPIId(for VPC):  0
    EgressQNum:            3

```

```
IngressQDepth(cells):          1000
IngressDiscardOption:          CLP hysteresis
IngressFrameDiscardThreshold   1000
IngressQCLPHigh(cells):        900
IngressQCLPLow(cells):         800
QCLPState:                      LOW
IngressEfcIThreshold(cells):   1000

UPCEnable:                      Enabled
PeakCellRate[0+1](cells/sec):  50
```

*!--- PINGS set at port speed are discarded.*

```
CellDelayVariation[0+1]:       10000 (micro secs)
PeakCellRate[0](cells/sec):    14364
CellDelayVariation[0]:         250000 (micro secs)
SustainedCellRate(cells/sec):  50
```

*!--- PINGS set at port speed are discarded.*

```
MaximumBurstSize(cells):       1000
SCRPolicing:                    CLP[0]
CLPTagEnable:                   Enabled
FrameGCRAEnable:               Disable

ForesightEnable:               Disable
InitialBurstSize(cells):        0
ForeSightPeakCellRate(cells/sec):  50
MinimumCellRate(cells/sec):     50
InitialCellRate(cells/sec):     50

LocalRemoteLpbkState:          Disable
ChanTestType:                  No Test
ChanTestState:                 Passed
ChanRTDresult:                 1 ms

Ingress percentage util:       100
Egress percentage util :       100
Egress Service Rate:           50
ChanOvrSubOvrRide:             Enabled
ChanNumNextAvailable : 17
Local VpId NextAvailable : 6
```

r3620#ping 2.2.2.2

```
Type escape sequence to abort.
Sending 5, 100-byte ICMP Echos to 2.2.2.2, timeout is 2 seconds:
.....
Success rate is 0 percent (0/5)
```

**After cnfupcvbr command is used to increase connection parameter:**

a1.1.10.AUSMB8.a > dspchan 200

```
ChanNum:                        200
RowStatus:                      Mod
ConnectionType:                 VCC
ServiceType:                    VBR
PortNum:                        1
VPI:                            10
VCI (For VCC):                 20
Local VPIId(for VPC):           0
EgressQNum:                     3
IngressQDepth(cells):          1000
IngressDiscardOption:          CLP hysteresis
IngressFrameDiscardThreshold   1000
```

```

IngressQCLPHigh(cells):          900
IngressQCLPLow(cells):          800
QCLPState:                       LOW
IngressEfciThreshold(cells):    1000

UPCEnable:                       Enabled
PeakCellRate[0+1](cells/sec):    3622
CellDelayVariation[0+1]:        25000 (micro secs)
PeakCellRate[0](cells/sec):     14364
CellDelayVariation[0]:          250000 (micro secs)
SustainedCellRate(cells/sec):    2048
MaximumBurstSize(cells):        1000
SCRPolicing:                     CLP[0]
CLPTagEnable:                   Enabled
FrameGCRAEnable:                Disable

ForesightEnable:                Disable
InitialBurstSize(cells):        0
ForeSightPeakCellRate(cells/sec): 3622
MinimumCellRate(cells/sec):     3622
InitialCellRate(cells/sec):     3622

LocalRemoteLpbkState:           Disable
ChanTestType:                   No Test
ChanTestState:                  Passed
ChanRTDresult:                  1 ms

Ingress percentage util:        100
Egress percentage util :        100
Egress Service Rate:            2633
ChanOvrSubOvrRide:             Enabled

ChanNumNextAvailable : 17
Local VpId NextAvailable : 16

```

```
r3620#ping 2.2.2.2
```

```

Type escape sequence to abort.
Sending 5, 100-byte ICMP Echos to 2.2.2.2, timeout is 2 seconds:
!!!!
Success rate is 100 percent (5/5), round-trip min/avg/max = 8/13/28 ms

```

## MC 3810

Command summary:

- **show version**
- **show run**
- **show fr pvc**
- **show contr t1 0**
- **show interface s0:0**
- **debug frame-relay lmi**

```
r3a#ping 2.2.2.1
```

```

Type escape sequence to abort.
Sending 5, 100-byte ICMP Echos to 2.2.2.1, timeout is 2 seconds:
!!!!
Success rate is 100 percent (5/5), round-trip min/avg/max = 104/134/144 ms

```

```
r3a#show version
```

```

Cisco Internetwork Operating System Software
IOS (tm) MC3810 Software (MC3810-JS-M), Version 12.0(4)T, RELEASE SOFTWARE (fc)

```

Copyright (c) 1986-1999 by cisco Systems, Inc.  
Compiled Wed 28-Apr-99 21:19 by kpma  
Image text-base: 0x00023000, data-base: 0x00AF1324

ROM: System Bootstrap, Version 11.3(1)MA1, MAINTENANCE INTERIM SOFTWARE  
ROM: MC3810 Software (MC3810-WBOOT-M), Version 11.3(1)MA1, MAINTENANCE INTERIM

r3a uptime is 2 hours, 51 minutes  
System restarted by reload  
System image file is "flash:mc3810-js-mz.120-4.T.bin"

Cisco MC3810 (MPC860) processor (revision 06.07) with 27648K/5120K bytes of mem.  
Processor board ID 09550018  
PPC860 PowerQUICC, partnum 0x0000, version A03(0x0013)  
Channelized E1, Version 1.0.  
Bridging software.  
X.25 software, Version 3.0.0.  
SuperLAT software copyright 1990 by Meridian Technology Corp).  
TN3270 Emulation software.  
Primary Rate ISDN software, Version 1.1.  
MC3810 SCB board (v05.A0)  
1 Multiflex T1(slot 3) RJ45 interface(v01.K0)  
1 Six-Slot Analog Voice Module (v03.K0)  
1 Analog FXS voice interface (v03.K0) port 1/1  
1 3-DSP(slot2) Voice Compression Module(v01.--)  
1 Ethernet/IEEE 802.3 interface(s)  
1 Serial network interface(s)  
2 Serial(sync/async) network interface(s)  
1 Channelized E1/PRI port(s)  
1 Channelized T1/PRI port(s)  
256K bytes of non-volatile configuration memory.  
8192K bytes of processor board System flash (INTEL28F016)

Configuration register is 0x2102

r3a#**show run**  
Building configuration...

Current configuration:  
!  
version 12.0  
service timestamps debug uptime  
service timestamps log uptime  
service password-encryption  
!  
hostname r3a  
enable password 7 016E2C  
!  
enable password  
!  
network-clock base-rate 56k  
ip subnet-zero  
no ip domain-lookup  
!  
!  
!  
controller T1 0  
framing esf  
linecode b8zs  
channel-group 0 timeslots 1-24 speed 64  
!  
interface Ethernet0  
ip address 172.16.150.53 255.255.255.0  
no ip directed-broadcast  
!  
interface Serial0

```

no ip address
no ip directed-broadcast
no ip mroute-cache
shutdown
no fair-queue
!
interface Serial1
no ip address
no ip directed-broadcast
shutdown
!
interface Serial0:0
ip address 2.2.2.2 255.255.255.0
no ip directed-broadcast
encapsulation frame-relay IETF
ip mroute-cache
frame-relay map ip 2.2.2.1 100 broadcast
!
interface Switch0
no ip address
no ip directed-broadcast
encapsulation frame-relay
no fair-queue
!
ip classless
ip route 0.0.0.0 0.0.0.0 172.16.150.1
no ip http server
!
!
!
line con 0
transport input none
line aux 0
line 2 3
line vty 0 4
exec-timeout 0 0
password 7 0236C1C
login
!
!
voice-port 1/1
timeouts call-disconnect 0
!
!
end

```

r3a#show fr pvc

PVC Statistics for interface Serial0:0 (Frame Relay DTE)

|          | Active | Inactive | Deleted | Static |
|----------|--------|----------|---------|--------|
| Local    | 1      | 0        | 0       | 0      |
| Switched | 0      | 0        | 0       | 0      |
| Unused   | 0      | 0        | 0       | 0      |

DLCI = 100, DLCI USAGE = LOCAL, PVC STATUS = ACTIVE, INTERFACE = Serial0:0

```

input pkts 140          output pkts 161          in bytes 104560
out bytes 106700       dropped pkts 0          in FECN pkts 0
in BECN pkts 0        out FECN pkts 0        out BECN pkts 0
in DE pkts 0          out DE pkts 0
out bcast pkts 0      out bcast bytes 0
pvc create time 02:42:19, last time pvc status changed 01:30:06

```

PVC Statistics for interface Switch0 (Frame Relay DTE)

r3a#show contr t1 0

T1 0 is up.

Applique type is Channelized T1

Cablelength is long gain36 0db

No alarms detected.

Slot 3 CSU Serial #08625843 Model TEB HWVersion 4.70 RX level = -0DB

Framing is ESF, Line Code is B8ZS, Clock Source is Line.

Data in current interval (567 seconds elapsed):

0 Line Code Violations, 0 Path Code Violations

0 Slip Secs, 0 Fr Loss Secs, 0 Line Err Secs, 0 Degraded Mins

0 Errored Secs, 0 Bursty Err Secs, 0 Severely Err Secs, 0 Unavail Secs

Data in Interval 1:

0 Line Code Violations, 0 Path Code Violations

0 Slip Secs, 0 Fr Loss Secs, 0 Line Err Secs, 0 Degraded Mins

0 Errored Secs, 0 Bursty Err Secs, 0 Severely Err Secs, 0 Unavail Secs

Data in Interval 2:

0 Line Code Violations, 0 Path Code Violations

0 Slip Secs, 0 Fr Loss Secs, 0 Line Err Secs, 0 Degraded Mins

0 Errored Secs, 0 Bursty Err Secs, 0 Severely Err Secs, 0 Unavail Secs

Data in Interval 3:

0 Line Code Violations, 0 Path Code Violations

0 Slip Secs, 0 Fr Loss Secs, 0 Line Err Secs, 0 Degraded Mins

0 Errored Secs, 0 Bursty Err Secs, 0 Severely Err Secs, 0 Unavail Secs

Data in Interval 4:

0 Line Code Violations, 0 Path Code Violations

0 Slip Secs, 0 Fr Loss Secs, 0 Line Err Secs, 0 Degraded Mins

0 Errored Secs, 0 Bursty Err Secs, 0 Severely Err Secs, 0 Unavail Secs

Data in Interval 5:

0 Line Code Violations, 0 Path Code Violations

0 Slip Secs, 0 Fr Loss Secs, 0 Line Err Secs, 0 Degraded Mins

0 Errored Secs, 0 Bursty Err Secs, 0 Severely Err Secs, 0 Unavail Secs

Data in Interval 6:

0 Line Code Violations, 0 Path Code Violations

0 Slip Secs, 0 Fr Loss Secs, 0 Line Err Secs, 0 Degraded Mins

0 Errored Secs, 0 Bursty Err Secs, 0 Severely Err Secs, 0 Unavail Secs

Data in Interval 7:

0 Line Code Violations, 0 Path Code Violations

0 Slip Secs, 0 Fr Loss Secs, 0 Line Err Secs, 0 Degraded Mins

0 Errored Secs, 0 Bursty Err Secs, 0 Severely Err Secs, 0 Unavail Secs

Data in Interval 8:

0 Line Code Violations, 0 Path Code Violations

0 Slip Secs, 0 Fr Loss Secs, 0 Line Err Secs, 0 Degraded Mins

0 Errored Secs, 0 Bursty Err Secs, 0 Severely Err Secs, 0 Unavail Secs

Data in Interval 9:

0 Line Code Violations, 0 Path Code Violations

0 Slip Secs, 0 Fr Loss Secs, 0 Line Err Secs, 0 Degraded Mins

0 Errored Secs, 0 Bursty Err Secs, 0 Severely Err Secs, 0 Unavail Secs

0 Line Code Violations, 0 Path Code Violations

0 Slip Secs, 0 Fr Loss Secs, 0 Line Err Secs, 0 Degraded Mins

0 Errored Secs, 0 Bursty Err Secs, 0 Severely Err Secs, 0 Unavail Secs

Data in Interval 8:

0 Line Code Violations, 0 Path Code Violations

0 Slip Secs, 0 Fr Loss Secs, 0 Line Err Secs, 0 Degraded Mins

0 Errored Secs, 0 Bursty Err Secs, 0 Severely Err Secs, 0 Unavail Secs

Data in Interval 9:

0 Line Code Violations, 0 Path Code Violations

0 Slip Secs, 0 Fr Loss Secs, 0 Line Err Secs, 0 Degraded Mins

0 Errored Secs, 0 Bursty Err Secs, 0 Severely Err Secs, 0 Unavail Secs

Data in Interval 10:

0 Line Code Violations, 0 Path Code Violations

0 Slip Secs, 0 Fr Loss Secs, 0 Line Err Secs, 0 Degraded Mins

0 Errored Secs, 0 Bursty Err Secs, 0 Severely Err Secs, 0 Unavail Secs

Data in Interval 11:

7 Line Code Violations, 0 Path Code Violations

2 Slip Secs, 0 Fr Loss Secs, 2 Line Err Secs, 0 Degraded Mins

1 Errored Secs, 0 Bursty Err Secs, 0 Severely Err Secs, 866 Unavail Secs

```
Total Data (last 11 15 minute intervals):
  7 Line Code Violations, 0 Path Code Violations,
  2 Slip Secs, 0 Fr Loss Secs, 2 Line Err Secs, 0 Degraded Mins,
  1 Errored Secs, 0 Bursty Err Secs, 0 Severely Err Secs, 866 Unavail Secs
```

```
r3a#show interface s0:0
```

```
Serial0:0 is up, line protocol is up
Hardware is PQUICC Serial
Internet address is 2.2.2.2/24
MTU 1500 bytes, BW 1536 Kbit, DLY 20000 usec,
  reliability 255/255, txload 1/255, rxload 1/255
Encapsulation FRAME-RELAY IETF, crc 16, loopback not set
Keepalive set (10 sec)
Scramble enabled
LMI enq sent 964, LMI stat recvd 966, LMI upd recvd 2, DTE LMI up
LMI enq recvd 0, LMI stat sent 0, LMI upd sent 0
LMI DLCI 1023 LMI type is CISCO frame relay DTE
FR SVC disabled, LAPF state down
Broadcast queue 0/64, broadcasts sent/dropped 0/0, interface broadcasts 0
Last input 00:00:04, output 00:00:04, output hang never
Last clearing of "show interface" counters 02:45:12
Input queue: 0/75/0 (size/max/drops); Total output drops: 0
Queueing strategy: weighted fair
Output queue: 0/1000/64/0 (size/max total/threshold/drops)
  Conversations 0/1/256 (active/max active/max total)
  Reserved Conversations 0/0 (allocated/max allocated)
5 minute input rate 0 bits/sec, 0 packets/sec
5 minute output rate 0 bits/sec, 0 packets/sec
  1108 packets input, 118434 bytes, 0 no buffer
  Received 0 broadcasts, 0 runts, 0 giants, 0 throttles
  0 input errors, 0 CRC, 0 frame, 0 overrun, 0 ignored, 0 abort
  1133 packets output, 119338 bytes, 0 underruns
  0 output errors, 0 collisions, 2 interface resets
  0 output buffer failures, 0 output buffers swapped out
  0 carrier transitions
```

**Note:** Because the **debug** commands generate a significant amount of output, use them only when traffic on the IP network is low, so other activity on the system is not adversely affected.

```
r3a#debug frame-relay lmi
```

```
Frame Relay LMI debugging is on
Displaying all Frame Relay LMI data
```

```
r3a#terminal monitor
```

```
% Console already monitors
```

```
r3a#
```

```
02:59:35: Serial0:0(out): StEnq, myseq 206, yourseen 53, DTE up
```

```
02:59:35: datagramstart = 0x1C98A18, datagramsize = 13
```

```
02:59:35: FR encap = 0xFCF10309
```

```
02:59:35: 00 75 01 01 01 03 02 CE 35
```

```
02:59:35:
```

```
02:59:35: Serial0:0(in): Status, myseq 206
```

```
02:59:35: RT IE 1, length 1, type 1
```

```
02:59:35: KA IE 3, length 2, yourseq 54, myseq 206
```

```
r3a#
```

```
02:59:45: Serial0:0(out): StEnq, myseq 207, yourseen 54, DTE up
```

```
02:59:45: datagramstart = 0x1C98A18, datagramsize = 13
```

```
02:59:45: FR encap = 0xFCF10309
```

```
02:59:45: 00 75 01 01 01 03 02 CF 36
```

```
02:59:45:
```

```
02:59:45: Serial0:0(in): Status, myseq 207
```

```
02:59:45: RT IE 1, length 1, type 1
```

```
02:59:45: KA IE 3, length 2, yourseq 55, myseq 207
```

# MGX 8220 FRSM-8T1

Command summary:

- **version**
- **dspfeature**
- **dsplns**
- **dspln**
- **dsports**
- **dsport**
- **dspchans**
- **dspchan**
- **tstcon**

```
a1.1.9.FRSM.a > version
***** Cisco Systems, Inc. AXIS FRSM-8P Card *****
Firmware Version      = 5.0.13
Backup Boot version = FR8_BT_1.0.02
ASCFRSM Xilinx file = cbslave.h
VxWorks (for Cisco Systems, Inc.) version 5.2 Rev B.
Kernel: WIND version 2.4.
Made on Wed Jun 21 16:15:40 PDT 2000.
Boot line:
```

```
a1.1.9.FRSM.a > dspfeature
```

```
Channelized: On
Rate Control: On
```

```
a1.1.9.FRSM.a > dsplns
```

| Line | Conn<br>Type | Type    | Status/Coding | Length   | XmtClock<br>Source | Alarm | Stats<br>Alarm |
|------|--------------|---------|---------------|----------|--------------------|-------|----------------|
| 9.1  | RJ-48        | dsx1ESF | Ena/dsx1B8ZS  | 0-131 ft | LocalTim           | No    | No             |
| 9.2  | RJ-48        | dsx1ESF | Dis/dsx1B8ZS  | 0-131 ft | LocalTim           |       |                |
| 9.3  | RJ-48        | dsx1ESF | Dis/dsx1B8ZS  | 0-131 ft | LocalTim           |       |                |
| 9.4  | RJ-48        | dsx1ESF | Dis/dsx1B8ZS  | 0-131 ft | LocalTim           |       |                |
| 9.5  | RJ-48        | dsx1ESF | Dis/dsx1B8ZS  | 0-131 ft | LocalTim           |       |                |
| 9.6  | RJ-48        | dsx1ESF | Dis/dsx1B8ZS  | 0-131 ft | LocalTim           |       |                |
| 9.7  | RJ-48        | dsx1ESF | Dis/dsx1B8ZS  | 0-131 ft | LocalTim           |       |                |
| 9.8  | RJ-48        | dsx1ESF | Dis/dsx1B8ZS  | 0-131 ft | LocalTim           |       |                |

```
LineNumOfValidEntries: 8
```

```
a1.1.9.FRSM.a > dspln 1
```

```
LineNum: 1
LineConnectorType: RJ-48
LineType: dsx1ESF
LineEnable: Enabled
LineCoding: dsx1B8ZS
LineLength: 0-131 ft
LineXmtClockSource: LocalTiming
LineLoopbackCommand: NoLoop
LineSendCode: NoCode
LineUsedTimeslotsBitMap: 0xffffffff
LineLoopbackCodeDetection: codeDetectDisabled
LineBertEnable: Disable
```

```
LineNumOfValidEntries: 8
```

a1.1.9.FRSM.a > **dsports**

| Port  | Ena/Speed | EQServ<br>Ratio | SignalType | T391 | T392 | N391 | N392 | N393 | Type     | AlarI |
|-------|-----------|-----------------|------------|------|------|------|------|------|----------|-------|
| 9.1.1 | Mod/1536k | 1               | StrataLMI  | 10   | 15   | 6    | 3    | 4    | frameRel | No    |

Number of ports: 1

PortDs0UsedLine1: 0x00ffffff  
PortDs0UsedLine2: 0x00000000  
PortDs0UsedLine3: 0x00000000  
PortDs0UsedLine4: 0x00000000  
PortDs0UsedLine5: 0x00000000  
PortDs0UsedLine6: 0x00000000  
PortDs0UsedLine7: 0x00000000  
PortDs0UsedLine8: 0x00000000  
PortNumNextAvailable: 155

a1.1.9.FRSM.a > **dsport 1**

SlotNum: 9  
PortLineNum: 1  
PortNum: 1  
PortRowStatus: Mod  
PortDs0Speed: 64k  
PortDs0ConfigBitMap(1stDS0): 0xffffffff(1)  
PortEqueueServiceRatio: 1  
PortFlagsBetweenFrames: 1  
PortSpeed: 1536kbps  
SignallingProtocolType: StrataLMI  
AsynchronousMsgs: UPD enabled  
T391LineIntegrityTimer: 10  
T392PollingVerificationTimer: 15  
N391FullStatusPollingCounter: 6  
N392ErrorThreshold: 3  
N393MonitoredEventCount: 4  
EnhancedLmi: On  
PortState: Active  
PortSignallingState: No Signalling Failure  
CLLMEnableStatus: Disable  
CLLMxmtStatusTimer: 0  
portType: frameRelay  
PortIngrPercentUtil: 100  
PortEgrPercentUtil: 100  
PortOversubscribed: False  
PortSvcStatus: Disable  
PortSvcInUse: Not In-Use  
PortSvcShareLcn: Card-based  
PortSvcLcnLow: 0  
PortSvcLcnHigh: 0  
PortSvcDlciLow: 0  
PortSvcDlciHigh: 0

PortDs0UsedLine1: 0x00ffffff  
PortDs0UsedLine2: 0x00000000  
PortDs0UsedLine3: 0x00000000  
PortDs0UsedLine4: 0x00000000  
PortDs0UsedLine5: 0x00000000  
PortDs0UsedLine6: 0x00000000  
PortDs0UsedLine7: 0x00000000  
PortDs0UsedLine8: 0x00000000  
PortNumNextAvailable: 164

a1.1.9.FRSM.a > **dspchans**

| DLCI      | Chan | EQ | I/EQDepth   | I/EQDEThre  | I/EECNThre | Fst/ DE | Type  | Alarm |
|-----------|------|----|-------------|-------------|------------|---------|-------|-------|
| 9.1.1.100 | 100  | 2  | 65535/65535 | 32767/32767 | 6553/6553  | Dis/Dis | SIW-X | No    |

Number of channels: 1

ChanNumNextAvailable: 44

a1.1.9.FRSM.a > **dspchan 100**

```

ChanNum: 100
ChanRowStatus: Mod
ChanPortNum: 1
ChanDLCI: 100
EgressQSelect: 2
IngressQDepth: 65535
IngressQDEThresh: 32767
IngressQECNThresh: 6553
EgressQDepth: 65535
EgressQDEThresh: 32767
EgressQECNThresh: 6553
DETaggingEnable: Disabled
CIR: 1536000
Bc: 5100
Be: 5100
IBS: 100
ForeSightEnable: Disabled
QIR: 4000
MIR: 4000
PIR: 4000
ChanLocalRemoteLpbkState: Disabled
ChanTestType: TestOff
ChanTestState: Passed
ChanRTDresult: 1 ms
ChanType: SIW-Xlat
ChanFECNmap: setEFCIzero
ChanDEtoCLPmap: mapCLP
ChanCLPtoDEmap: mapDE
ChanFrConnType: PVC
ChanIngrPercentUtil: 100
ChanEgrPercentUtil: 100
ChanEgrSrvRate: 1536000
ChanOvrSubOvrRide: Enabled

```

ChanNumNextAvailable: 45

a1.1.9.FRSM.a > **tstcon 100**

TestCon in progress.

TestCon Passed.

## BPX 8600

Command summary:

- **dspcds**
- **dspnode**
- **dsptrks**
- **dsptrkcnf**
- **dspcons**
- **dspcon**
- **dspchstats**

- **tstconseg**
- **dspalms**
- **dspcons -abit**
- **dspcon in abit alarm**

b3 TRM SuperUser BPX 8600 9.1.18 Sep. 22 2000 17:08 GMT

| FrontCard |         |      |          |        | BackCard |         |         |      |          |           |         |
|-----------|---------|------|----------|--------|----------|---------|---------|------|----------|-----------|---------|
| Type      | Rev     | Type | Rev      | Status | Type     | Rev     | Type    | Rev  | Status   |           |         |
| 1         | Empty   |      |          |        | 9        | BXM-155 | CDB     | MM-4 | BA       | Standby-T |         |
| 2         | BNI-T3  | CJM  | T3-3     | BE     | Active   | 10      | BXM-155 | EJB  | MM-4     | BA        | Standby |
| 3         | BNI155E | DJR  | Empty    |        | Standby  | 11      | BNI155E | DJR  | MMF-2    | AC        | Standby |
| 4         | Empty   |      |          |        |          | 12      | Empty   |      |          |           |         |
| 5         | BXM-T3  | CDE  | TE3-12BA |        | Standby  | 13      | BXM-T3  | BDY  | TE3-12BA |           | Standby |
| 6         | ASI-T3  | CDF  | T3-2     | BE     | Standby  | 14      | Empty   |      |          |           |         |
| 7         | BCC-3   | CLM  | LM-2     | AC     | Active   | 15      | ASM     | ACC  | LMASM    | AC        | Active  |
| 8         | BCC-3   | CLM  | LM-2     | AC     | Standby  |         |         |      |          |           |         |

Last Command: **dspcds**

b3 TRM SuperUser BPX 8600 9.1.18 Sep. 22 2000 17:08 GMT

BPX 8600 Interface Shelf Information

| Trunk | Name | Type | Part Id | Ctrl Id | Alarm |
|-------|------|------|---------|---------|-------|
| 2.1   | a1   | AXIS | -       | -       | MIN   |

Last Command: **dspnode**

b3 TRM SuperUser BPX 8600 9.1.18 Sep. 22 2000 17:09 GMT

| TRK | Type | Current Line Alarm Status | Other End |
|-----|------|---------------------------|-----------|
| 2.1 | T3   | Clear - OK                | a1(AXIS)  |

Last Command: **dsptrks**

b3 TRM SuperUser BPX 8600 9.1.18 Sep. 22 2000 17:09 GMT

|                      |                             |             |                     |           |
|----------------------|-----------------------------|-------------|---------------------|-----------|
| TRK 2.1 Config       | T3                          | [96000 cps] | BNI-T3 slot:        | 2         |
| Transmit Rate:       |                             | 96000       | VPC Conns disabled: | --        |
| Subrate data rate:   |                             | --          | Line framing:       | PLCP      |
| Line DS-0 map:       |                             | --          | coding:             | --        |
| Statistical Reserve: | 1000                        | cps         | recv impedance:     | --        |
| Idle code:           |                             | 7F hex      | cable type:         |           |
| Max Channels/Port:   |                             | --          | length:             | 0-225 ft. |
| Connection Channels: | 2027                        |             | Pass sync:          | Yes       |
| Traffic:             | V,TS,NTS,FR,FST,CBR,VBR,ABR |             | Loop clock:         | No        |
| SVC Vpi Min:         |                             | --          | HCS Masking:        | Yes       |
| SVC Channels:        |                             | --          | Payload Scramble:   | No        |
| SVC Bandwidth:       |                             | -- cps      | Frame Scramble:     | --        |
| Restrict CC traffic: | No                          |             | Virtual Trunk Type: | --        |
| Link type:           | Terrestrial                 |             | Virtual Trunk VPI:  | --        |
| Routing Cost:        | 10                          |             | Deroute delay time: | 0 seconds |

Last Command: **dsptrkcnf 2.1**

b3 TRM SuperUser BPX 8600 9.1.18 Sep. 22 2000 17:09 GMT

| Local Channel | Remote NodeName | Remote Channel | State | Type | Route Avoid COS O |
|---------------|-----------------|----------------|-------|------|-------------------|
| 2.1.9.100     | b3              | 2.1.10.200     | Ok    | atfr |                   |
| 2.1.10.200    | b3              | 2.1.9.100      | Ok    | atfr |                   |

Last Command: **dspscons**

b3 TRM SuperUser BPX 8600 9.1.18 Sep. 22 2000 17:09 GMT

| Conn: 2.1.9.100 | b3      | 2.1.10.200  | atfr | Status:OK     |
|-----------------|---------|-------------|------|---------------|
| PCR(0+1)        | % Util  | CDVT(0+1)   | FBTC | SCR           |
| 2000/2000       | 100/100 | 25000/25000 | y    | 1000/1000     |
|                 |         |             |      | MBS 1000/1000 |
|                 |         |             |      | PLC 3         |

Path: Route information not applicable for local connections

|    |                    |    |               |
|----|--------------------|----|---------------|
| b3 | BNI-T3 : OK        | b3 | BNI-T3 : OK   |
|    | Line 2.1 : OK      |    | Line 2.1 : OK |
|    | OAM Cell RX: Clear |    | NNI : OK      |
|    | NNI : OK           |    |               |

| Conn: 2.1.9.100 | b3      | 2.1.10.200  | atfr      | Status:OK |
|-----------------|---------|-------------|-----------|-----------|
| PCR(0+1)        | % Util  | CDVT(0+1)   | SCR       | MBS       |
| 2000/2000       | 100/100 | 25000/25000 | 1000/1000 | 1000/1000 |

|          |           |       |     |
|----------|-----------|-------|-----|
| Policing | VC Qdepth | EFCI  | IBS |
| 3        | 1280/1280 | 35/35 | 1/1 |

Last Command: **dspscon 2.1.9.100**

b3 TRM SuperUser BPX 8600 9.1.18 Sep. 22 2000 17:13 GMT

| Local Channel | Remote NodeName | Remote Channel | State | Type | Route Avoid COS O |
|---------------|-----------------|----------------|-------|------|-------------------|
| 2.1.9.100     | b3              | 2.1.10.200     | Ok    | atfr |                   |
| 2.1.10.200    | b3              | 2.1.9.100      | Ok    | atfr |                   |

This Command: **dspschstats 2.1.10.200**

**Channel stats is not supported**  
**Enter channel:**

b3 TRM SuperUser BPX 8600 9.1.18 Sep. 22 2000 17:10 GMT

| Conn: 2.1.9.100 | b3      | 2.1.10.200  | atfr      | Status:OK |
|-----------------|---------|-------------|-----------|-----------|
| PCR(0+1)        | % Util  | CDVT(0+1)   | SCR       | MBS       |
| 2000/2000       | 100/100 | 25000/25000 | 1000/1000 | 1000/1000 |

|          |           |       |     |
|----------|-----------|-------|-----|
| Policing | VC Qdepth | EFCI  | IBS |
| 3        | 1280/1280 | 35/35 | 1/1 |

This Command: **tstconseg 2.1.9.100**

**Not allowed on feeder trunk endpoints**  
**Channel:**

!-- When no corresponding connection exists on the FRSM or AUSM:

b3 TRM SuperUser BPX 8600 9.1.18 Sep. 22 2000 21:46 GMT

Alarm summary (Configured alarm slots: None)  
 Connections Failed: None  
 TRK Alarms: None  
 Line Alarms: None  
 Cards Failed: None  
 Slots Alarmed: None  
 Missing Cards: None  
 Remote Node Alarms: None  
**Connection A-bit/AIS Alarms: 2**

Interface Shelf Alarms: 1 Minor  
 ASM Alarms: None

Last Command: **dspalms**

b3 TRM SuperUser BPX 8600 9.1.18 Sep. 22 2000 21:46 GMT

| Local Channel | Remote NodeName | Remote Channel | State | Local A-bit | Remote A-bit |
|---------------|-----------------|----------------|-------|-------------|--------------|
| 2.1.9.100     | b3              | 2.1.10.200     | Ok    | Failed      | Failed       |
| 2.1.10.200    | b3              | 2.1.9.100      | Ok    | Failed      | Failed       |

Last Command: **dspcons -abit**

b3 TRM SuperUser BPX 8600 9.1.18 Sep. 22 2000 21:47 GMT

| Conn:     | 2.1.9.100 | b3          | 2.1.10.200 | atfr      | Status:OK   |
|-----------|-----------|-------------|------------|-----------|-------------|
| PCR(0+1)  | % Util    | CDVT(0+1)   | FBTC       | SCR       | MBS PLC     |
| 2000/2000 | 100/100   | 25000/25000 | y          | 1000/1000 | 1000/1000 3 |

Path: Route information not applicable for local connections

|    |                           |    |                           |
|----|---------------------------|----|---------------------------|
| b3 | BNI-T3 : OK               | b3 | BNI-T3 : OK               |
|    | Line 2.1 : OK             |    | Line 2.1 : OK             |
|    | OAM Cell RX: Clear        |    | NNI : Rmt Segment Failure |
|    | NNI : Rmt Segment Failure |    |                           |

Last Command: **dspcon 2.1.9.100**

*!--- After the frame relay side has been configured on the MGX 8220 FRSM:*

b3 TRM SuperUser BPX 8600 9.1.18 Sep. 22 2000 21:55 GMT

| Conn:     | 2.1.9.100 | b3          | 2.1.10.200 | atfr      | Status:OK   |
|-----------|-----------|-------------|------------|-----------|-------------|
| PCR(0+1)  | % Util    | CDVT(0+1)   | FBTC       | SCR       | MBS PLC     |
| 2000/2000 | 100/100   | 25000/25000 | y          | 1000/1000 | 1000/1000 3 |

Path: Route information not applicable for local connections

|    |                    |    |                           |
|----|--------------------|----|---------------------------|
| b3 | BNI-T3 : OK        | b3 | BNI-T3 : OK               |
|    | Line 2.1 : OK      |    | Line 2.1 : OK             |
|    | OAM Cell RX: Clear |    | NNI : Rmt Segment Failure |
|    | NNI : OK           |    |                           |

Last Command: **dspcon 2.1.9.100**

*!--- When both frame relay and ATM sides have been configured on the MGX 8220 FRSM  
!--- and AUSM:*

b3 TRM SuperUser BPX 8600 9.1.18 Sep. 22 2000 21:58 GMT

|           |           |             |            |           |           |     |
|-----------|-----------|-------------|------------|-----------|-----------|-----|
| Conn:     | 2.1.9.100 | b3          | 2.1.10.200 | atfr      | Status:OK |     |
| PCR(0+1)  | % Util    | CDVT(0+1)   | FBTC       | SCR       | MBS       | PLC |
| 2000/2000 | 100/100   | 25000/25000 | y          | 1000/1000 | 1000/1000 | 3   |

Path: Route information not applicable for local connections

|    |              |       |    |          |      |
|----|--------------|-------|----|----------|------|
| b3 | BNI-T3       | : OK  | b3 | BNI-T3   | : OK |
|    | Line 2.1     | : OK  |    | Line 2.1 | : OK |
|    | OAM Cell RX: | Clear |    | NNI      | : OK |
|    | NNI          | : OK  |    |          |      |

Last Command: **dspscon 2.1.9.100**

---

## Related Information

- [AUSM/B IMA Configuration and Troubleshooting Guide](#)
- [Configuring ATM–Frame Relay Service Interworking](#)
- [Troubleshooting ATM Links on the 7x00 IMA Port Adapter](#)
- [Cisco WAN Switching Solutions – Cisco Documentation](#)
- [Guide to New Names and Colors for WAN Switching Products](#)
- [Software Center – WAN Switching Software \( registered customers only\)](#)
- [Technical Support – Cisco Systems](#)

---

[Contacts & Feedback](#) | [Help](#) | [Site Map](#)

© 2008 – 2009 Cisco Systems, Inc. All rights reserved. [Terms & Conditions](#) | [Privacy Statement](#) | [Cookie Policy](#) | [Trademarks of Cisco Systems, Inc.](#)

---

Updated: Oct 23, 2009

Document ID: 22203

---