

NAT: Local and Global Definitions

Document ID: 4606

Introduction

Prerequisites

Requirements

Components Used

Conventions

Term Definitions

Examples

Define Inside Local and Inside Global Addresses

Define Outside Local and Outside Global Addresses

Define All Local and Global Addresses

Related Information

Introduction

This document defines and clarifies the Network Address Translation (NAT) terms of inside local, inside global, outside local, and outside global. Refer to the Network Address Translation White Paper for further information on network services offered by NAT.

Prerequisites

Requirements

There are no specific requirements for this document.

Components Used

This document is not restricted to specific software and hardware versions.

Conventions

Refer to the Cisco Technical Tips Conventions for more information on document conventions.

Term Definitions

Cisco defines these terms as:

- **Inside local address** The IP address assigned to a host on the inside network. This is the address configured as a parameter of the computer OS or received via dynamic address allocation protocols such as DHCP. The address is likely not a legitimate IP address assigned by the Network Information Center (NIC) or service provider.
- **Inside global address** A legitimate IP address assigned by the NIC or service provider that represents one or more inside local IP addresses to the outside world.
- **Outside local address** The IP address of an outside host as it appears to the inside network. Not necessarily a legitimate address, it is allocated from an address space routable on the inside.
- **Outside global address** The IP address assigned to a host on the outside network by the host owner. The address is allocated from a globally routable address or network space.

These definitions still leave a lot to be interpreted. For this example, this document redefines these terms by first defining local address and global address. Keep in mind that the terms inside and outside are NAT definitions. Interfaces on a NAT router are defined as inside or outside with the NAT configuration commands, **ip nat inside** and **ip nat outside**. Networks to which these interfaces connect can then be thought of as inside networks or outside networks, respectively.

- **Local address** A local address is any address that appears on the inside portion of the network.
- **Global address** A global address is any address that appears on the outside portion of the network.

Packets sourced on the inside portion of the network have an inside local address as the source address and an outside local address as the destination address of the packet, while the packet resides on the inside portion of the network. When that same packet gets switched to the outside network, the source of the packet is now known as the inside global address and the destination of the packet is known as the outside global address.

Conversely, when a packet is sourced on the outside portion of the network, while it is on the outside network, its source address is known as the outside global address. The destination of the packet is known as the inside global address. When the same packet gets switched to the inside network, the source address is known as the outside local address and the destination of the packet is known as the inside local address.

This image provides an example.

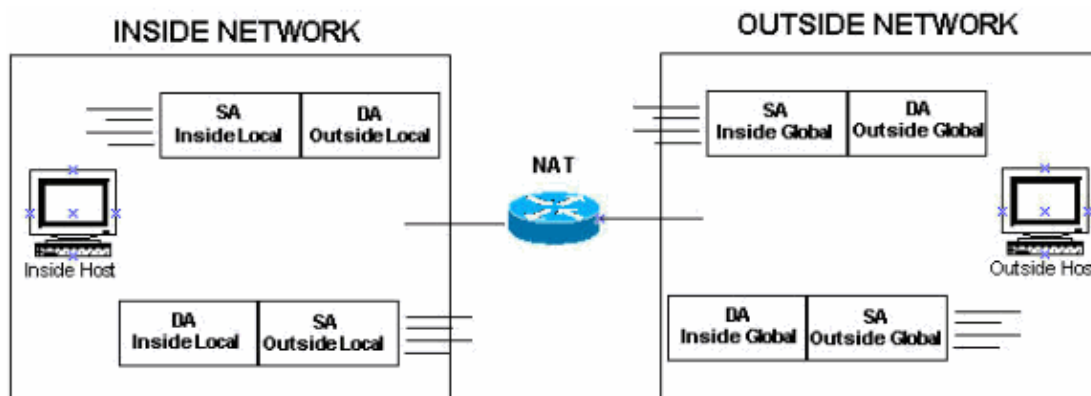

Examples

These sections examine these terms more closely and use this topology and examples.

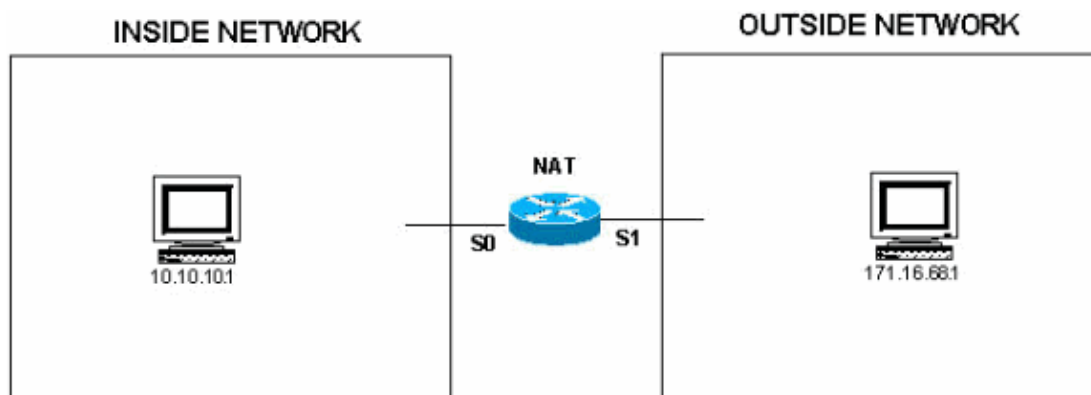

Define Inside Local and Inside Global Addresses

In this configuration, when the NAT router receives a packet on its inside interface with a source address of 10.10.10.1, the source address is translated to 171.16.68.5. This also means that when the NAT router receives

a packet on its outside interface with a destination address of 171.16.68.5, the destination address is translated to 10.10.10.1.

```
ip nat inside source static 10.10.10.1 171.16.68.5

!--- Inside host is known by the outside host as 171.16.68.5.

interface s 0
ip nat inside

interface s 1
ip nat outside
```

You can issue the **show ip nat translations** command in order to verify the NAT translations in the router. In the ideal condition, the output of the **show ip nat translations** command is as shown here:

```
Router#show ip nat translations

Pro      Inside global      Inside local      Outside local      Outside global
---      -
icmp     171.16.68.5       10.10.10.1       ---                ---
```

When the packet moves from the inside network to the outside network, the output of the **show ip nat translations** command is as shown here:

```
Router#show ip nat translations

Pro      Inside global      Inside local      Outside local      Outside global
---      -
icmp     171.16.68.5:15   10.10.10.1:15   171.16.68.1:15   171.16.68.1:15
---      -
icmp     171.16.68.5       10.10.10.1       ---                ---
```

Note: In this output of the NAT translations, the protocol entry shows ICMP because Ping is used to validate the entries. The Outside Local and Outside Global entries will have the same IP address of the Outside host, which is 171.16.68.1.

The local addresses are addresses that appear on the inside cloud. Global addresses are addresses that appear on the outside cloud. Because of the way NAT is configured, the inside addresses are the only addresses that are translated. Therefore, the inside local address is different from the inside global address.

This is what the packets look like when they are on the inside network and on the outside network.

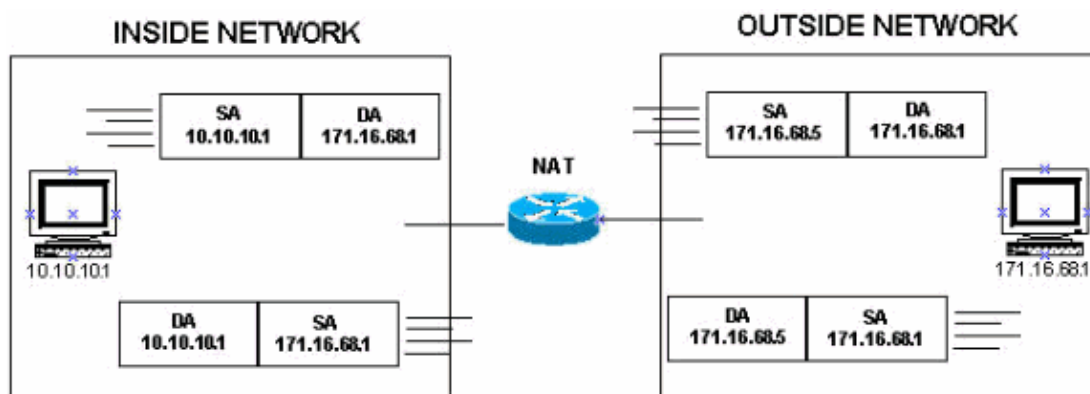

Define Outside Local and Outside Global Addresses

In this configuration, when the NAT router receives a packet on its outside interface with a source address of 171.16.68.1, the source address is translated to 10.10.10.5. This also means that if the NAT router receives a

packet on its inside interface with a destination address of 10.10.10.5, the destination address is translated to 171.16.68.1.

```
ip nat outside source static 171.16.68.1 10.10.10.5

!--- Outside host is known to the inside host as 10.10.10.5.

interface s 0
ip nat inside

interface s 1
ip nat outside
```

In the ideal condition, the output of the **show ip nat translations** command is as shown here:

```
Router#show ip nat translations

Pro      Inside global          Inside local           Outside local          Outside global
-----
          --- ---
                                ---
                                10.10.10.5
                                171.16.68.1
```

When the packet moves from the outside network to the inside network, the output of the **show ip nat translations** command is as shown here:

```
Router#show ip nat translations

Pro      Inside global          Inside local           Outside local          Outside global
-----
          --- ---
          10.10.10.1:37  10.10.10.1:37        10.10.10.5:37        171.16.68.1:37
icmp
```

Note: The Inside Global and Inside Local entries will have the same IP address of the Inside host, which is 10.10.10.1.

The local addresses are addresses that appear on the inside cloud. Global addresses are addresses that appear on the outside cloud. In this example, because of the way NAT is configured, only the outside addresses get translated. Therefore, the outside local address is different from the outside global address.

This is what the packets look like when they are on the inside network and on the outside network.

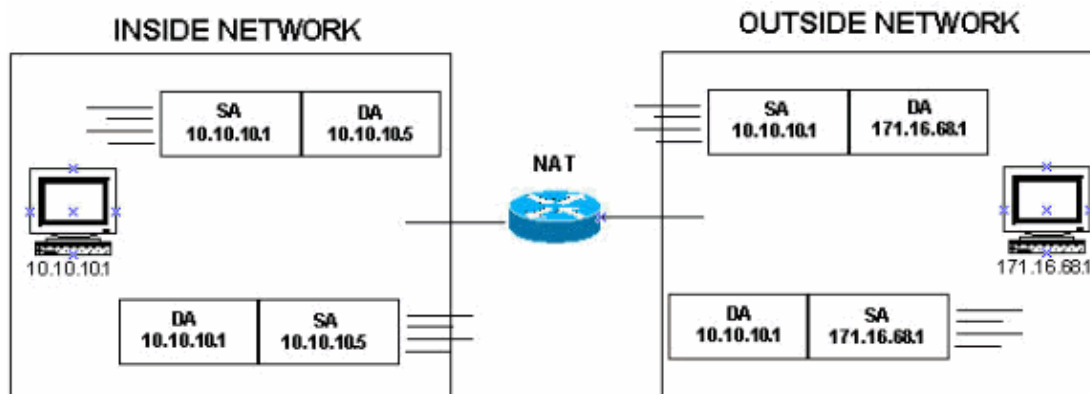

Define All Local and Global Addresses

In this configuration, when the NAT router receives a packet on its inside interface with a source address of 10.10.10.1, the source address is translated to 171.16.68.5. When the NAT router receives a packet on its outside interface with a source address of 171.16.68.1, the source address is translated to 10.10.10.5.

This also means that when the NAT router receives a packet on its outside interface with a destination address of 171.16.68.5, the destination address is translated to 10.10.10.1. Also, when the NAT router receives a packet on its inside interface with a destination address of 10.10.10.5, the destination address is translated to 171.16.68.1.

```
ip nat inside source static 10.10.10.1 171.16.68.5

!--- Inside host is known to the outside host as 171.16.68.5.

ip nat outside source static 171.16.68.1 10.10.10.5

!--- Outside host is known to the inside host as 10.10.10.5.

interface s 0
ip nat inside

interface s 1
ip nat outside
```

In the ideal condition, the output of the **show ip nat translations** command is as shown here:

```
Router#show ip nat translations

Pro   Inside global      Inside local          Outside local          Outside global
---   ---              ---                  ---                   ---
      171.16.68.5      10.10.10.1           10.10.10.5            171.16.68.1
```

The local addresses are addresses that appear on the inside cloud, and the global addresses are addresses that appear on the outside cloud. Because of how NAT is configured in this case, both the inside addresses and the outside addresses are translated. Therefore, the inside local addresses are different from the inside global addresses and the outside local addresses are different from the outside global addresses.

When the packet transfer is initiated from both the sides, the output of the **show ip nat translations** command is as shown here:

```
Router#show ip nat translations

Pro Inside global      Inside local          Outside local          Outside global
--- ---              ---                  ---                   ---
icmp 10.10.10.1:4      10.10.10.1:4         10.10.10.5:4         171.16.68.1:4
icmp 171.16.68.5:39   10.10.10.1:39        171.16.68.1:39       171.16.68.1:39
---  171.16.68.5        10.10.10.1           ---                   ---
```

This is what the packets look like when they are on the inside network and on the outside network.

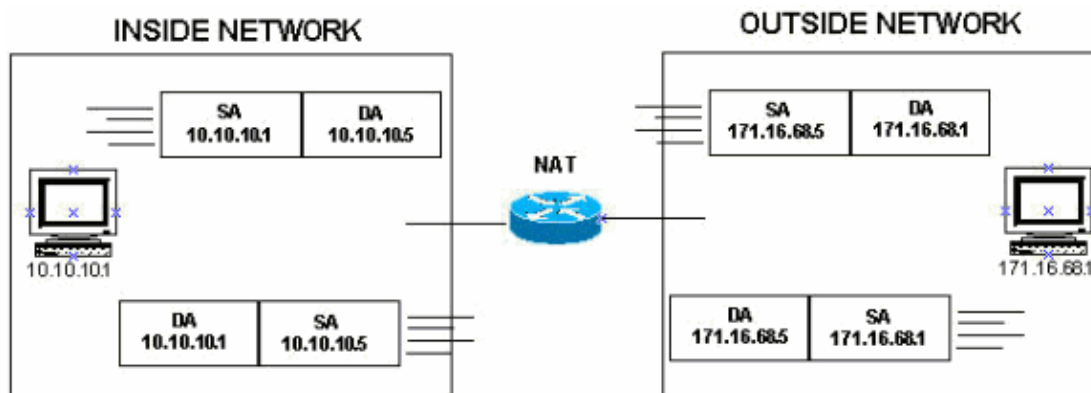

In summary, the terms local and global are actually very straight forward when you think of them in terms of where they appear in the network. Local addresses appear on the inside portion of the network while global addresses appear on the outside portion of the network.

Related Information

- **[Configuring Network Address Translation: Getting Started](#)**
 - **[NAT Support Page](#)**
 - **[IP Routing Support Page](#)**
 - **[Technical Support & Documentation – Cisco Systems](#)**
-

All contents are Copyright © 2006–2007 Cisco Systems, Inc. All rights reserved. Important Notices and Privacy Statement.

Updated: Aug 24, 2006

Document ID: 4606
