



Cisco Access Router USB Flash Memory Module and USB eToken Hardware Installation Guide

This document describes how to connect the Cisco universal serial bus (USB) flash memory modules and the Aladdin Knowledge Systems USB eToken Pro keys to the Cisco router USB ports, and how to troubleshoot issues with the USB modules. This document contains the following sections:

- [Cisco 90-Day Limited Hardware Warranty Terms, page 2](#)
- [Description, page 3](#)
- [Connecting a USB Module to the Router USB Port, page 4](#)
- [Related Documentation, page 6](#)
- [Obtaining Documentation, page 6](#)
- [Documentation Feedback, page 7](#)
- [Cisco Product Security Overview, page 7](#)
- [Obtaining Technical Assistance, page 8](#)
- [Obtaining Additional Publications and Information, page 10](#)

Cisco 90-Day Limited Hardware Warranty Terms

There are special terms applicable to your hardware warranty and various services that you can use during the warranty period. Your formal Warranty Statement, including the warranties and license agreements applicable to Cisco software, is available on Cisco.com. Follow these steps to access and download the *Cisco Information Packet* and your warranty and license agreements from Cisco.com.

1. Launch your browser, and go to this URL:

http://www.cisco.com/univercd/cc/td/doc/es_inpk/cetrans.htm

The Warranties and License Agreements page appears.

2. To read the *Cisco Information Packet*, follow these steps:

- a. Click the **Information Packet Number** field, and make sure that the part number 78-5235-03B0 is highlighted.
- b. Select the language in which you would like to read the document.
- c. Click **Go**.

The Cisco Limited Warranty and Software License page from the Information Packet appears.

- d. Read the document online, or click the **PDF** icon to download and print the document in Adobe Portable Document Format (PDF).



Note You must have Adobe Acrobat Reader to view and print PDF files. You can download the reader from Adobe's website: <http://www.adobe.com>

3. To read translated and localized warranty information about your product, follow these steps:

- a. Enter this part number in the Warranty Document Number field:
78-5236-01C0
- b. Select the language in which you would like to read the document.
- c. Click **Go**.

The Cisco warranty page appears.

- d. Review the document online, or click the **PDF** icon to download and print the document in Adobe Portable Document Format (PDF).

You can also contact the Cisco service and support website for assistance:

http://www.cisco.com/public/Support_root.shtml.

Duration of Hardware Warranty

Ninety (90) days.

Replacement, Repair, or Refund Policy for Hardware

Cisco or its service center will use commercially reasonable efforts to ship a replacement part within ten (10) working days after receipt of a Return Materials Authorization (RMA) request. Actual delivery times can vary, depending on the customer location.

Cisco reserves the right to refund the purchase price as its exclusive warranty remedy.

To Receive a Return Materials Authorization (RMA) Number

Contact the company from whom you purchased the product. If you purchased the product directly from Cisco, contact your Cisco Sales and Service Representative.

Complete the information below, and keep it for reference:

Company product purchased from	
Company telephone number	
Product model number	
Product serial number	
Maintenance contract number	

Description

Some Cisco access router models have USB ports that can be used with Cisco USB flash memory modules or with the Aladdin USB eToken Pro key. These USB modules can be used with a supported Cisco access router for the following functions:

- The Aladdin Knowledge Systems USB eToken Pro key provides a secure means of storing and deploying information, such as a bootstrap configuration or VPN credentials, apart from the router chassis. The USB eToken uses smart card technology to protect a small area of memory. The USB eToken grants access using a personal identification number (PIN). When IP Security (IPSec) VPN credentials are stored on the USB eToken, they are outside the router. When the USB eToken is inserted in a USB port, and when the user enters the PIN and unlocks the USB eToken, the user retrieves the credentials and copies them into running memory. When the USB eToken is removed, the router erases the credentials from running memory, ensuring that they cannot be retrieved from the router itself.



Note For more information about the eToken Pro key by Aladdin Knowledge Systems, see the Aladdin website.

- The Cisco USB flash memory module can be used to store an image or configuration file. Unlike the USB eToken, the Cisco USB flash memory module is nonsecure; but, is available in 64-MB, 128-MB, and 256-MB capacities.



Note The following routers support booting directly from a USB device: Cisco 1841, 2801, 2811, 2821, 2851, 3825, and 3845 routers.

- Touchless or low-touch provisioning—Combined with either the Cisco CNS 2100 Series Intelligence Engine or a Trivial File Transfer Protocol (TFTP) server, the USB ports can support a touchless or low-touch provisioning application. Both USB module options can store a bootstrap configuration: in a nonsecure memory area in the Cisco modules, and as a secure solution using the Aladdin USB eToken. The stored bootstrap configuration allows the router to boot and establish baseline connectivity. Once a connection is established, the router may contact an intelligence engine or TFTP server to download its full configuration or a new Cisco IOS software image. This capability eliminates the requirement to send a skilled technician to the customer premises for each installation.

**Note**

For detailed information about these features, configuring the router to support these features, and the Cisco IOS commands that support USB modules, see the [Cisco IOS USB Flash Module and USB eToken Support](#) document. For more information about supported router platforms, see the documents listed in the “[Related Documentation](#)” section on page 6.

Connecting a USB Module to the Router USB Port

To connect a Cisco USB flash memory module or the Aladdin USB eToken to a router USB port, simply insert the module into the port as shown in [Figure 1](#). The module can be inserted in only one way, and it can be inserted or removed whether the router is powered up or not.

**Caution**

Do not remove a USB flash memory module when a read or write operation to the USB flash memory module is in progress. The router might reload, or the USB flash memory module card can be damaged.

**Note**

Cisco routers support only Cisco USB flash memory modules and the Aladdin USB eToken Pro key.

Figure 1 Connecting a USB Module to a Router USB Port

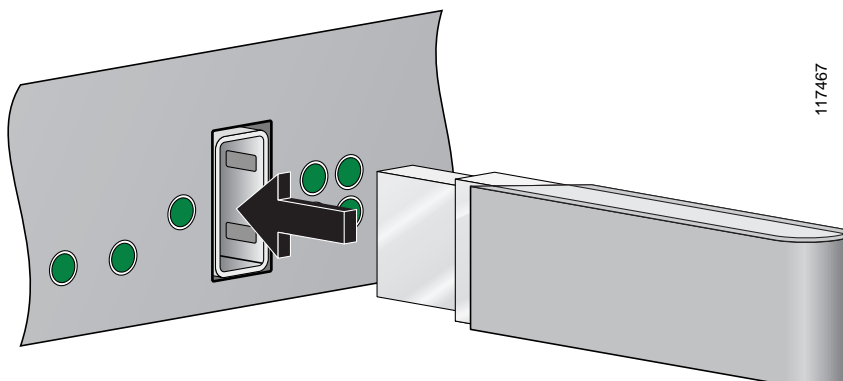

Using a USB Extension Cable

Some Cisco access router models have USB ports on the front side of the router; other models have USB ports on the back side of the router. Depending on your router model and the direction in which it is mounted on a rack, you may need a USB extension cable to provide easy access to the USB ports. In addition, some routers have two USB ports. In order to use two USB modules on a router with two USB ports, USB extension cables are required, because the USB ports are too close together to accommodate two modules side-by-side.

**Note**

USB hubs are not supported on Cisco Access routers.

To connect a USB extension cable, plug the male end of the USB extension cable into the USB port on the router, and route the female end of the USB extension cable to a convenient place on the rack to make access to the USB ports easy.

Figure 2 shows an example of how to connect the USB extension cable to a router.



Caution

Some USB extension cables have exposed metal parts when the USB flash memory module is plugged into them. This can cause the USB flash memory module and the router to which it is connected to be vulnerable to electrostatic discharge (ESD) damage. If you are using a USB extension cable, be sure to use an appropriate cable and to take precautions to avoid ESD damage. For more information about avoiding ESD damage, see the hardware installation document for your router. For more information about USB extension cables, see the *Cisco Access Router USB Flash Module and USB eToken Hardware Installation Guide* at the following URL:

http://www.cisco.com/en/US/products/ps6247/prod_installation_guide09186a008068f3dd.html

Figure 2 Connecting a USB Extension Cable

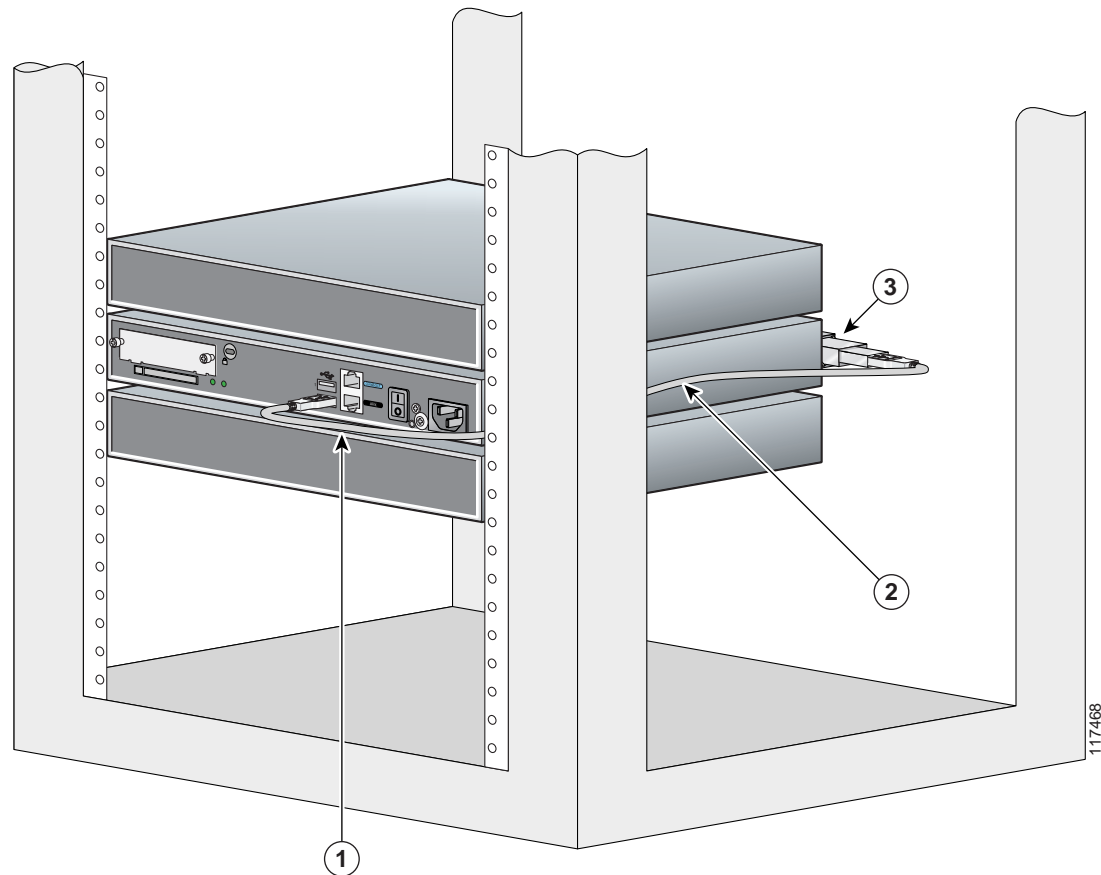

1	USB extension cable connection to router USB port
2	USB extension cable connection to USB flash memory module or USB eToken
3	USB flash memory module or USB eToken

Related Documentation

Use this document with the following guides:

- [Cisco IOS USB Flash Module and USB eToken Support](#)
- Cisco 1800 Series Integrated Services Routers (Modular) Hardware Installation documents
- Cisco 2800 Series Hardware Installation documents
- Cisco 3800 Series Hardware Installation documents

Obtaining Documentation

Cisco documentation and additional literature are available on Cisco.com. This section explains the product documentation resources that Cisco offers.

Cisco.com

You can access the most current Cisco documentation at this URL:

<http://www.cisco.com/techsupport>

You can access the Cisco website at this URL:

<http://www.cisco.com>

You can access international Cisco websites at this URL:

http://www.cisco.com/public/countries_languages.shtml

Product Documentation DVD

The Product Documentation DVD is a library of technical product documentation on a portable medium. The DVD enables you to access installation, configuration, and command guides for Cisco hardware and software products. With the DVD, you have access to the HTML documentation and some of the PDF files found on the Cisco website at this URL:

<http://www.cisco.com/univercd/home/home.htm>

The Product Documentation DVD is created and released regularly. DVDs are available singly or by subscription. Registered Cisco.com users can order a Product Documentation DVD (product number DOC-DOCDVD= or DOC-DOCDVD=SUB) from Cisco Marketplace at the Product Documentation Store at this URL:

<http://www.cisco.com/go/marketplace/docstore>

Ordering Documentation

You must be a registered Cisco.com user to access Cisco Marketplace. Registered users may order Cisco documentation at the Product Documentation Store at this URL:

<http://www.cisco.com/go/marketplace/docstore>

If you do not have a user ID or password, you can register at this URL:

<http://tools.cisco.com/RPF/register/register.do>

Documentation Feedback

You can provide feedback about Cisco technical documentation on the Cisco Technical Support & Documentation site area by entering your comments in the feedback form available in every online document.

Cisco Product Security Overview

Cisco provides a free online Security Vulnerability Policy portal at this URL:

http://www.cisco.com/en/US/products/products_security_vulnerability_policy.html

From this site, you will find information about how to do the following:

- Report security vulnerabilities in Cisco products
- Obtain assistance with security incidents that involve Cisco products
- Register to receive security information from Cisco

A current list of security advisories, security notices, and security responses for Cisco products is available at this URL:

<http://www.cisco.com/go/psirt>

To see security advisories, security notices, and security responses as they are updated in real time, you can subscribe to the Product Security Incident Response Team Really Simple Syndication (PSIRT RSS) feed. Information about how to subscribe to the PSIRT RSS feed is found at this URL:

http://www.cisco.com/en/US/products/products_psirt_rss_feed.html

Reporting Security Problems in Cisco Products

Cisco is committed to delivering secure products. We test our products internally before we release them, and we strive to correct all vulnerabilities quickly. If you think that you have identified a vulnerability in a Cisco product, contact PSIRT:

- For emergencies only—security-alert@cisco.com

An emergency is either a condition in which a system is under active attack or a condition for which a severe and urgent security vulnerability should be reported. All other conditions are considered nonemergencies.

- For nonemergencies—psirt@cisco.com

In an emergency, you can also reach PSIRT by telephone:

- 1 877 228-7302
- 1 408 525-6532

**Tip**

We encourage you to use Pretty Good Privacy (PGP) or a compatible product (for example, GnuPG) to encrypt any sensitive information that you send to Cisco. PSIRT can work with information that has been encrypted with PGP versions 2.x through 9.x.

Never use a revoked encryption key or an expired encryption key. The correct public key to use in your correspondence with PSIRT is the one linked in the Contact Summary section of the Security Vulnerability Policy page at this URL:

http://www.cisco.com/en/US/products/products_security_vulnerability_policy.html

The link on this page has the current PGP key ID in use.

If you do not have or use PGP, contact PSIRT to find other means of encrypting the data before sending any sensitive material.

Product Alerts and Field Notices

Modifications to or updates about Cisco products are announced in Cisco Product Alerts and Cisco Field Notices. You can receive Cisco Product Alerts and Cisco Field Notices by using the Product Alert Tool on Cisco.com. This tool enables you to create a profile and choose those products for which you want to receive information.

To access the Product Alert Tool, you must be a registered Cisco.com user. (To register as a Cisco.com user, go to this URL: <http://tools.cisco.com/RPF/register/register.do>) Registered users can access the tool at this URL: <http://tools.cisco.com/Support/PAT/do/ViewMyProfiles.do?local=en>

Obtaining Technical Assistance

Cisco Technical Support provides 24-hour-a-day award-winning technical assistance. The Cisco Technical Support & Documentation website on Cisco.com features extensive online support resources. In addition, if you have a valid Cisco service contract, Cisco Technical Assistance Center (TAC) engineers provide telephone support. If you do not have a valid Cisco service contract, contact your reseller.

Cisco Technical Support & Documentation Website

The Cisco Technical Support & Documentation website provides online documents and tools for troubleshooting and resolving technical issues with Cisco products and technologies. The website is available 24 hours a day at this URL:

<http://www.cisco.com/techsupport>

Access to all tools on the Cisco Technical Support & Documentation website requires a Cisco.com user ID and password. If you have a valid service contract but do not have a user ID or password, you can register at this URL:

<http://tools.cisco.com/RPF/register/register.do>

**Note**

Use the **Cisco Product Identification Tool** to locate your product serial number before submitting a request for service online or by phone. You can access this tool from the Cisco Technical Support & Documentation website by clicking the **Tools & Resources** link, clicking the **All Tools (A-Z)** tab, and then choosing **Cisco Product Identification Tool** from the alphabetical list. This tool offers three search options: by product ID or model name; by tree view; or, for certain products, by copying and pasting **show** command output. Search results show an illustration of your product with the serial number label location highlighted. Locate the serial number label on your product and record the information before placing a service call.

**Tip**

Displaying and Searching on Cisco.com

If you suspect that the browser is not refreshing a web page, force the browser to update the web page by holding down the Ctrl key while pressing F5.

To find technical information, narrow your search to look in technical documentation, not the entire Cisco.com website. On the Cisco.com home page, click the **Advanced Search** link under the Search box and then click the **Technical Support & Documentation** radio button.

To provide feedback about the Cisco.com website or a particular technical document, click **Contacts & Feedback** at the top of any Cisco.com web page.

Submitting a Service Request

Using the online TAC Service Request Tool is the fastest way to open S3 and S4 service requests. (S3 and S4 service requests are those in which your network is minimally impaired or for which you require product information.) After you describe your situation, the TAC Service Request Tool provides recommended solutions. If your issue is not resolved using the recommended resources, your service request is assigned to a Cisco engineer. The TAC Service Request Tool is located at this URL:

<http://www.cisco.com/techsupport/servicerequest>

For S1 or S2 service requests, or if you do not have Internet access, contact the Cisco TAC by telephone. (S1 or S2 service requests are those in which your production network is down or severely degraded.) Cisco engineers are assigned immediately to S1 and S2 service requests to help keep your business operations running smoothly.

To open a service request by telephone, use one of the following numbers:

Asia-Pacific: +61 2 8446 7411

Australia: 1 800 805 227

EMEA: +32 2 704 55 55

USA: 1 800 553 2447

For a complete list of Cisco TAC contacts, go to this URL:

<http://www.cisco.com/techsupport/contacts>

Definitions of Service Request Severity

To ensure that all service requests are reported in a standard format, Cisco has established severity definitions.

Severity 1 (S1)—An existing network is “down” or there is a critical impact to your business operations. You and Cisco will commit all necessary resources around the clock to resolve the situation.

Severity 2 (S2)—Operation of an existing network is severely degraded, or significant aspects of your business operations are negatively affected by inadequate performance of Cisco products. You and Cisco will commit full-time resources during normal business hours to resolve the situation.

Severity 3 (S3)—Operational performance of the network is impaired while most business operations remain functional. You and Cisco will commit resources during normal business hours to restore service to satisfactory levels.

Severity 4 (S4)—You require information or assistance with Cisco product capabilities, installation, or configuration. There is little or no effect on your business operations.

Obtaining Additional Publications and Information

Information about Cisco products, technologies, and network solutions is available from various online and printed sources.

- The Cisco Online Subscription Center is the website where you can sign up for a variety of Cisco e-mail newsletters and other communications. Create a profile and then select the subscriptions that you would like to receive. To visit the Cisco Online Subscription Center, go to this URL:
<http://www.cisco.com/offer/subscribe>
- The *Cisco Product Quick Reference Guide* is a handy, compact reference tool that includes brief product overviews, key features, sample part numbers, and abbreviated technical specifications for many Cisco products that are sold through channel partners. It is updated twice a year and includes the latest Cisco channel product offerings. To order and find out more about the *Cisco Product Quick Reference Guide*, go to this URL:
<http://www.cisco.com/go/guide>
- Cisco Marketplace provides a variety of Cisco books, reference guides, documentation, and logo merchandise. Visit Cisco Marketplace, the company store, at this URL:
<http://www.cisco.com/go/marketplace/>
- Cisco Press publishes a wide range of general networking, training, and certification titles. Both new and experienced users will benefit from these publications. For current Cisco Press titles and other information, go to Cisco Press at this URL:
<http://www.ciscopress.com>
- *Internet Protocol Journal* is a quarterly journal published by Cisco Systems for engineering professionals involved in designing, developing, and operating public and private internets and intranets. You can access the *Internet Protocol Journal* at this URL:
<http://www.cisco.com/ipj>
- Networking products offered by Cisco Systems, as well as customer support services, can be obtained at this URL:
<http://www.cisco.com/en/US/products/index.html>

- Networking Professionals Connection is an interactive website where networking professionals share questions, suggestions, and information about networking products and technologies with Cisco experts and other networking professionals. Join a discussion at this URL:
<http://www.cisco.com/discuss/networking>
- “What’s New in Cisco Documentation” is an online publication that provides information about the latest documentation releases for Cisco products. Updated monthly, this online publication is organized by product category to direct you quickly to the documentation for your products. You can view the latest release of “What’s New in Cisco Documentation” at this URL:
<http://www.cisco.com/univercd/cc/td/doc/abtnicd/136957.htm>
- World-class networking training is available from Cisco. You can view current offerings at this URL:
<http://www.cisco.com/en/US/learning/index.html>

This document is to be used in conjunction with the documents listed in the “[Related Documentation](#)” section.

CCVP, the Cisco logo, and the Cisco Square Bridge logo are trademarks of Cisco Systems, Inc.; Changing the Way We Work, Live, Play, and Learn is a service mark of Cisco Systems, Inc.; and Access Registrar, Aironet, BPX, Catalyst, CCDA, CCDP, CCIE, CCIP, CCNA, CCNP, CCSP, Cisco, the Cisco Certified Internetwork Expert logo, Cisco IOS, Cisco Press, Cisco Systems, Cisco Systems Capital, the Cisco Systems logo, Cisco Unity, Enterprise/Solver, EtherChannel, EtherFast, EtherSwitch, Fast Step, Follow Me Browsing, FormShare, GigaDrive, HomeLink, Internet Quotient, IOS, iPhone, IP/TV, iQ Expertise, the iQ logo, iQ Net Readiness Scorecard, iQuick Study, LightStream, Linksys, MeetingPlace, MGX, Networking Academy, Network Registrar, PIX, ProConnect, ScriptShare, SMARTnet, StackWise, The Fastest Way to Increase Your Internet Quotient, and TransPath are registered trademarks of Cisco Systems, Inc. and/or its affiliates in the United States and certain other countries.

All other trademarks mentioned in this document or Website are the property of their respective owners. The use of the word partner does not imply a partnership relationship between Cisco and any other company. (0709R)

Copyright © 2006 Cisco Systems, Inc. All rights reserved.

