



Installation and Configuration Note for the Catalyst 4500 Series Supervisor Engine V-10GE

Product Numbers: WS-X4516-10GE = Catalyst 4500 Series Supervisor Engine V-10GE

This publication describes how to install and verify the operation of the Catalyst 4500 series Supervisor Engine V-10GE. Refer to the software configuration guide for your switch for configuration information for the supervisor engines and switching modules.

Contents

This document contains these sections:

- [Safety Overview, page 2](#)
- [Supervisor Engine V-10GE, page 7](#)
- [Port Cabling Specifications, page 11](#)
- [Installing the Supervisor Engine, page 13](#)
- [Attaching Module Interface Cables, page 16](#)
- [Configuring Your Supervisor Engine, page 19](#)
- [X2 Handling Guidelines and Installation, page 19](#)
- [Related Documentation, page 29](#)
- [Obtaining Documentation and Submitting a Service Request, page 29](#)
- [Obtaining Technical Assistance, page 30](#)



Corporate Headquarters:
Cisco Systems, Inc., 170 West Tasman Drive, San Jose, CA 95134-1706 USA

Copyright © 2004 Cisco Systems, Inc. All rights reserved.

Safety Overview

Throughout this publication, safety warnings appear in procedures that can harm you if performed incorrectly. A warning symbol precedes each warning statement.



Warning

IMPORTANT SAFETY INSTRUCTIONS

This warning symbol means danger. You are in a situation that could cause bodily injury. Before you work on any equipment, be aware of the hazards involved with electrical circuitry and be familiar with standard practices for preventing accidents. Use the statement number provided at the end of each warning to locate its translation in the translated safety warnings that accompanied this device. Statement 1071

SAVE THESE INSTRUCTIONS

Waarschuwing

BELANGRIJKE VEILIGHEIDSINSTRUCTIES

Dit waarschuwingssymbool betekent gevaar. U verkeert in een situatie die lichamelijk letsel kan veroorzaken. Voordat u aan enige apparatuur gaat werken, dient u zich bewust te zijn van de bij elektrische schakelingen betrokken risico's en dient u op de hoogte te zijn van de standaard praktijken om ongelukken te voorkomen. Gebruik het nummer van de verklaring onderaan de waarschuwing als u een vertaling van de waarschuwing die bij het apparaat wordt geleverd, wilt raadplegen.

BEWAAR DEZE INSTRUCTIES

Varoitus

TÄRKEITÄ TURVALLISUUSOHJEITA

Tämä varoitusmerkki merkitsee vaaraa. Tilanne voi aiheuttaa ruumiillisia vammoja. Ennen kuin käsittelet laitteistoa, huomioi sähköpiirien käsittelyyn liittyvät riskit ja tutustu onnettomuuksien yleisiin ehkäisytapoihin. Turvallisuusvaroitusten käännökset löytyvät laitteen mukana toimitettujen käännettyjen turvallisuusvaroitusten joukosta varoitusten lopussa näkyvien lausuntonumeroiden avulla.

SÄILYTÄ NÄMÄ OHJEET

Attention

IMPORTANTES INFORMATIONS DE SÉCURITÉ

Ce symbole d'avertissement indique un danger. Vous vous trouvez dans une situation pouvant entraîner des blessures ou des dommages corporels. Avant de travailler sur un équipement, soyez conscient des dangers liés aux circuits électriques et familiarisez-vous avec les procédures couramment utilisées pour éviter les accidents. Pour prendre connaissance des traductions des avertissements figurant dans les consignes de sécurité traduites qui accompagnent cet appareil, référez-vous au numéro de l'instruction situé à la fin de chaque avertissement.

CONSERVEZ CES INFORMATIONS

Warnung	<p>WICHTIGE SICHERHEITSHINWEISE</p> <p>Dieses Warnsymbol bedeutet Gefahr. Sie befinden sich in einer Situation, die zu Verletzungen führen kann. Machen Sie sich vor der Arbeit mit Geräten mit den Gefahren elektrischer Schaltungen und den üblichen Verfahren zur Vorbeugung vor Unfällen vertraut. Suchen Sie mit der am Ende jeder Warnung angegebenen Anweisungsnummer nach der jeweiligen Übersetzung in den übersetzten Sicherheitshinweisen, die zusammen mit diesem Gerät ausgeliefert wurden.</p> <p>BEWAHREN SIE DIESE HINWEISE GUT AUF.</p>
Avvertenza	<p>IMPORTANTI ISTRUZIONI SULLA SICUREZZA</p> <p>Questo simbolo di avvertenza indica un pericolo. La situazione potrebbe causare infortuni alle persone. Prima di intervenire su qualsiasi apparecchiatura, occorre essere al corrente dei pericoli relativi ai circuiti elettrici e conoscere le procedure standard per la prevenzione di incidenti. Utilizzare il numero di istruzione presente alla fine di ciascuna avvertenza per individuare le traduzioni delle avvertenze riportate in questo documento.</p> <p>CONSERVARE QUESTE ISTRUZIONI</p>
Advarsel	<p>VIKTIGE SIKKERHETSINSTRUKSJONER</p> <p>Dette advarselssymbolet betyr fare. Du er i en situasjon som kan føre til skade på person. Før du begynner å arbeide med noe av utstyret, må du være oppmerksom på farene forbundet med elektriske kretser, og kjenne til standardprosedyrer for å forhindre ulykker. Bruk nummeret i slutten av hver advarsel for å finne oversettelsen i de oversatte sikkerhetsadvarslene som fulgte med denne enheten.</p> <p>TA VARE PÅ DISSE INSTRUKSJONENE</p>
Aviso	<p>INSTRUÇÕES IMPORTANTES DE SEGURANÇA</p> <p>Este símbolo de aviso significa perigo. Você está em uma situação que poderá ser causadora de lesões corporais. Antes de iniciar a utilização de qualquer equipamento, tenha conhecimento dos perigos envolvidos no manuseio de circuitos elétricos e familiarize-se com as práticas habituais de prevenção de acidentes. Utilize o número da instrução fornecido ao final de cada aviso para localizar sua tradução nos avisos de segurança traduzidos que acompanham este dispositivo.</p> <p>GUARDE ESTAS INSTRUÇÕES</p>
¡Advertencia!	<p>INSTRUCCIONES IMPORTANTES DE SEGURIDAD</p> <p>Este símbolo de aviso indica peligro. Existe riesgo para su integridad física. Antes de manipular cualquier equipo, considere los riesgos de la corriente eléctrica y familiarícese con los procedimientos estándar de prevención de accidentes. Al final de cada advertencia encontrará el número que le ayudará a encontrar el texto traducido en el apartado de traducciones que acompaña a este dispositivo.</p> <p>GUARDE ESTAS INSTRUCCIONES</p>

Varning! VIKTIGA SÄKERHETSANVISNINGAR

Denna varningssignal signalerar fara. Du befinner dig i en situation som kan leda till personskada. Innan du utför arbete på någon utrustning måste du vara medveten om farorna med elkretsar och känna till vanliga förfaranden för att förebygga olyckor. Använd det nummer som finns i slutet av varje varning för att hitta dess översättning i de översatta säkerhetsvarningar som medföljer denna anordning.

SPARA DESSA ANVISNINGAR**FONTOS BIZTONSÁGI ELOÍRÁSOK**

Ez a figyelmeztető jel veszélyre utal. Sérülésveszélyt rejtő helyzetben van. Mielőtt bármely berendezésen munkát végezte, legyen figyelemmel az elektromos áramkörök okozta kockázatokra, és ismerkedjen meg a szokásos balesetvédelmi eljárásokkal. A kiadványban szereplő figyelmeztetések fordítása a készülékhez mellékelt biztonsági figyelmeztetések között található; a fordítás az egyes figyelmeztetések végén látható szám alapján kereshető meg.

ORIZZE MEG EZEKET AZ UTASÍTÁSOKAT!**Предупреждение****ВАЖНЫЕ ИНСТРУКЦИИ ПО СОБЛЮДЕНИЮ ТЕХНИКИ БЕЗОПАСНОСТИ**

Этот символ предупреждения обозначает опасность. То есть имеет место ситуация, в которой следует опасаться телесных повреждений. Перед эксплуатацией оборудования выясните, каким опасностям может подвергаться пользователь при использовании электрических цепей, и ознакомьтесь с правилами техники безопасности для предотвращения возможных несчастных случаев. Воспользуйтесь номером заявления, приведенным в конце каждого предупреждения, чтобы найти его переведенный вариант в переводе предупреждений по безопасности, прилагаемом к данному устройству.

СОХРАНИТЕ ЭТИ ИНСТРУКЦИИ**警告** 重要的安全性说明

此警告符号代表危险。您正处于可能受到严重伤害的工作环境中。在您使用设备开始工作之前，必须充分意识到触电的危险，并熟练掌握防止事故发生的标准工作程序。请根据每项警告结尾提供的声明号码来找到此设备的安全性警告说明的翻译文本。

请保存这些安全性说明

警告 安全上の重要な注意事項

「危険」の意味です。人身事故を予防するための注意事項が記述されています。装置の取り扱い作業を行うときは、電気回路の危険性に注意し、一般的な事故防止策に留意してください。警告の各国語版は、各注意事項の番号を基に、装置に付属の「Translated Safety Warnings」を参照してください。

これらの注意事項を保管しておいてください。

주의 **중요 안전 지침**

이 경고 기호는 위험을 나타냅니다. 작업자가 신체 부상을 일으킬 수 있는 위험한 환경에 있습니다. 장비에 작업을 수행하기 전에 전기 회로와 관련된 위험을 숙지하고 표준 작업 관례를 숙지하여 사고를 방지하십시오. 각 경고의 마지막 부분에 있는 경고문 번호를 참조하여 이 장치와 함께 제공되는 번역된 안전 경고문에서 해당 번역문을 찾으십시오.

이 지시 사항을 보관하십시오.

Aviso **INSTRUÇÕES IMPORTANTES DE SEGURANÇA**

Este símbolo de aviso significa perigo. Você se encontra em uma situação em que há risco de lesões corporais. Antes de trabalhar com qualquer equipamento, esteja ciente dos riscos que envolvem os circuitos elétricos e familiarize-se com as práticas padrão de prevenção de acidentes. Use o número da declaração fornecido ao final de cada aviso para localizar sua tradução nos avisos de segurança traduzidos que acompanham o dispositivo.

GUARDE ESTAS INSTRUÇÕES**Advarsel** **VIGTIGE SIKKERHEDSANVISNINGER**

Dette advarselssymbol betyder fare. Du befinder dig i en situation med risiko for legemeskadedigelse. Før du begynder arbejde på udstyr, skal du være opmærksom på de involverede risici, der er ved elektriske kredsløb, og du skal sætte dig ind i standardprocedurer til undgåelse af ulykker. Brug erklæringsnummeret efter hver advarsel for at finde oversættelsen i de oversatte advarsler, der fulgte med denne enhed.

GEM DISSE ANVISNINGER**تحذير****إرشادات الأمان الهامة**

يوضح رمز التحذير هذا وجود خطر. وهذا يعني أنك متواجد في مكان قد ينتج عنه التعرض للإصابات. قبل بدء العمل، احذر مخاطر التعرض للصدمات الكهربائية وكن على علم بالإجراءات القياسية للحيولة دون وقوع أي حوادث. استخدم رقم البيان الموجود في آخر كل تحذير لتحديد مكان ترجمته داخل تحذيرات الأمان المترجمة التي تأتي مع الجهاز. قم بحفظ هذه الإرشادات

Upozorenje **VAŽNE SIGURNOSNE NAPOMENE**

Ovaj simbol upozorenja predstavlja opasnost. Nalazite se u situaciji koja može prouzročiti tjelesne ozljede. Prije rada s bilo kojim uređajem, morate razumjeti opasnosti vezane uz električne sklopove, te biti upoznati sa standardnim načinima izbjegavanja nesreća. U prevedenim sigurnosnim upozorenjima, priloženima uz uređaj, možete prema broju koji se nalazi uz pojedino upozorenje pronaći i njegov prijevod.

SAČUVAJTE OVE UPUTE

Upozornění DŮLEŽITÉ BEZPEČNOSTNÍ POKYNY

Tento upozorňující symbol označuje nebezpečí. Jste v situaci, která by mohla způsobit nebezpečí úrazu. Před prací na jakémkoliv vybavení si uvědomte nebezpečí související s elektrickými obvody a seznamte se se standardními opatřeními pro předcházení úrazům. Podle čísla na konci každého upozornění vyhledejte jeho překlad v přeložených bezpečnostních upozorněních, která jsou přiložena k zařízení.

USCHOVEJTE TYTO POKYNY**Προειδοποίηση ΣΗΜΑΝΤΙΚΕΣ ΟΔΗΓΙΕΣ ΑΣΦΑΛΕΙΑΣ**

Αυτό το προειδοποιητικό σύμβολο σημαίνει κίνδυνο. Βρίσκεστε σε κατάσταση που μπορεί να προκαλέσει τραυματισμό. Πριν εργαστείτε σε οποιοδήποτε εξοπλισμό, να έχετε υπόψη σας τους κινδύνους που σχετίζονται με τα ηλεκτρικά κυκλώματα και να έχετε εξοικειωθεί με τις συνήθειες πρακτικές για την αποφυγή ατυχημάτων. Χρησιμοποιήστε τον αριθμό δήλωσης που παρέχεται στο τέλος κάθε προειδοποίησης, για να εντοπίσετε τη μετάφρασή της στις μεταφρασμένες προειδοποιήσεις ασφαλείας που συνοδεύουν τη συσκευή.

ΦΥΛΑΞΤΕ ΑΥΤΕΣ ΤΙΣ ΟΔΗΓΙΕΣ**אזהרה****הוראות בטיחות חשובות**

סימן אזהרה זה מסמל סכנה. אתה נמצא במצב העלול לגרום לפציעה. לפני שתעבוד עם ציוד כלשהו, עליך להיות מודע לסכנות הכרוכות במעגלים חשמליים ולהכיר את הנהלים המקובלים למניעת תאונות. השתמש במספר ההוראה המסופק בסופה של כל אזהרה כדי לאתר את התרגום באזהרות הבטיחות המתורגמות שמצורפות להתקן.

שמור הוראות אלה**Opomena VAŽNI BEZBEDNOSNI NAPATSTVIJA**

Симболот за предупредување значи опасност. Се наоѓате во ситуација што може да предизвика телесни повреди. Пред да работите со опремата, бидете свесни за ризикот што постои кај електричните кола и треба да ги познавате стандардните постапки за спречување на несреќни случаи. Искористете го бројот на изјавата што се наоѓа на крајот на секое предупредување за да го најдете неговиот период во преведените безбедносни предупредувања што се испорачани со уредот.

ЧУВАЈТЕ ГИ ОВИЕ НАПАТСТВИЈА

Ostrzeżenie WAŻNE INSTRUKCJE DOTYCZĄCE BEZPIECZEŃSTWA

Ten symbol ostrzeżenia oznacza niebezpieczeństwo. Zachodzi sytuacja, która może powodować obrażenia ciała. Przed przystąpieniem do prac przy urządzeniach należy zapoznać się z zagrożeniami związanymi z układami elektrycznymi oraz ze standardowymi środkami zapobiegania wypadkom. Na końcu każdego ostrzeżenia podano numer, na podstawie którego można odszukać tłumaczenie tego ostrzeżenia w dołączonym do urządzenia dokumencie z tłumaczeniami ostrzeżeń.

NINIEJSZE INSTRUKCJE NALEŻY ZACHOWAĆ**Upozornenie DÔLEŽITÉ BEZPEČNOSTNÉ POKYNY**

Tento varovný symbol označuje nebezpečenstvo. Nachádzate sa v situácii s nebezpečenstvom úrazu. Pred prácou na akomkoľvek vybavení si uvedomte nebezpečenstvo súvisiace s elektrickými obvodmi a oboznámte sa so štandardnými opatreniami na predchádzanie úrazom. Podľa čísla na konci každého upozornenia vyhľadajte jeho preklad v preložených bezpečnostných upozorneniach, ktoré sú priložené k zariadeniu.

USCHOVAJTE SI TENTO NÁVOD

Supervisor Engine V-10GE

This section describes the Catalyst 4500 series Supervisor Engine V-10GE (WS-X4516-10GE). See [Figure 1](#). This supervisor engine provides data path and data control for all network interfaces, and provides 10-Gigabit Ethernet interfaces for uplinks.

The Supervisor Engine V-10GE is supported in the Catalyst 4503, 4506, 4507R, and 4510R switches. It is not supported in Catalyst 4003 or 4006 switches. On the Catalyst 4503, and 4506 switches, you can install the Supervisor Engine V-10GE only in slot 1. On the Catalyst 4507R or 4510R switch, you install the primary supervisor engine in slot 1, and you can install an optional redundant supervisor engine in slot 2. The supervisors in slots 1 and 2 of a redundant system must be of the same type.

The supervisor engine is hot swappable, but packets are not forwarded when the last supervisor engine has been removed from the switch. When a supervisor engine is reinserted into the switch, the supervisor reboots.

Figure 1 Catalyst 4500 Series Supervisor Engine V-10GE (WS-X4516-10GE)

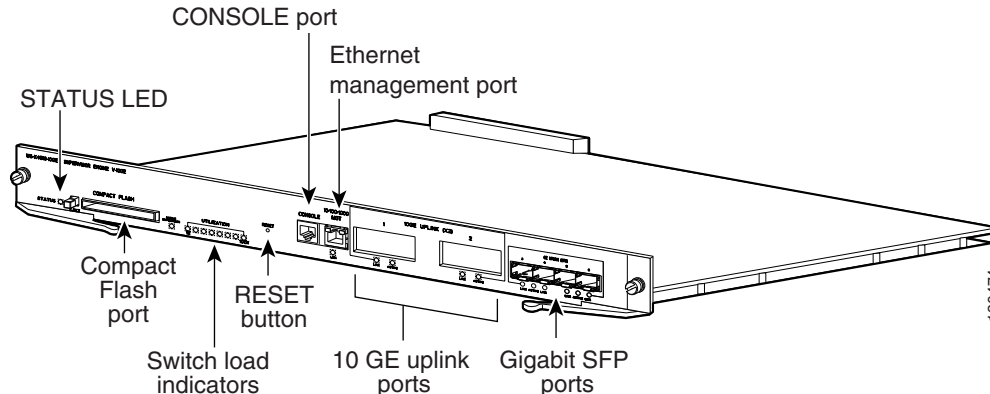

The supervisor engine includes interfaces for SNMP, console, and Telnet, and provides management functions, such as environmental status monitoring.

The Supervisor Engine V-10GE provides the following features:

- 512-MB onboard SDRAM memory
- 64-MB onboard flash memory (in addition to compact flash memory)
- Compact flash port
- 136-Gbps switching capacity, 102 million packets-per-second actual forwarding rate
- Support for up to 55,000 MAC addresses for Layer 2 switching (up to 64,000 entries, 16-way associative lookup table)
- Support for up to 4,000 VLANs
 - 802.1Q VLAN tagging on all ports
 - Cisco Inter Switch Link (ISL) tagging on all ports
- Up to 64,000 unicast and multicast forwarding entries, expandable to 256,000 unicast and multicast IPV4 forwarding information base (FIB) entries
- Support for all Catalyst 4500 series switching modules (except WS-X4232-L3 and WS-X4019)
- Default Layer 2 forwarding at startup (hardware based)
- Broadcast suppression on a per-port basis
- Multicast suppression on a per-port basis
- Unicast suppression on a per-port basis
- EtherChannel at 10/100/1000 Mbps and 10Gbps
- Protocol filtering on a per-port basis
- Dynamic protocol filtering
- Support for IEEE 802.3x flow control
- Hardware-based Layer 3 switching
- Hardware-based multicast
- Hardware-based access lists
- Supervisor engine redundancy between primary and standby supervisor engines in Catalyst 4510R and Catalyst 4507R

- 802.1Q tunneling
- Storm control in hardware
- The Catalyst 4500 Series NetFlow Services Card (WS-F4531) functionality is built in, no upgrade is needed for Netflow services.

Features of the Supervisor Engine Front Panel

The following sections describe the LEDs, connectors, and switches on the Catalyst 4500 series Supervisor Engine V-10GE:

- [LEDs, page 9](#)
- [10-Gigabit Ethernet Uplink Ports, page 10](#)
- [Gigabit Ethernet SFP Uplink Ports, page 10](#)
- [Ethernet Management Port, page 10](#)
- [Console Port, page 10](#)
- [Reset Button, page 11](#)
- [Compact Flash Port, page 11](#)

LEDs

[Table 1](#) describes the LEDs on the supervisor engine front panel.

Table 1 Supervisor Engine LEDs (WS-X4516-10GE)

LED	LED Status	Description
STATUS	Green	All diagnostic tests passed.
	Red	A test failed.
	Orange	System boot or diagnostic test is in progress.
	Off	Module is disabled.
UTILIZATION	Green 1–100%	If the switch is operational, this display indicates the current traffic load over the backplane (as an approximate percentage).
Link	Green	The link is operational.
	Orange	The link is disabled by user.
	Flashing orange	The power-on self-test indicates a faulty port.
	Off	No signal is detected or there is a link configuration failure.

Table 1 Supervisor Engine LEDs (WS-X4516-10GE) (Continued)

LED	LED Status	Description
Active		Indicates whether the uplink port is active.
	Green	The port is active.
	Off	The port is not active.

10-Gigabit Ethernet Uplink Ports

The 10-Gigabit Ethernet uplink ports operate in full-duplex mode only. These ports use the hot-swappable 10GBASE-LR long-reach X2 optical transceivers. The X2s have SC connectors to interface with multimode fiber (MMF) and single-mode fiber (SMF) cable. For further information on X2s, see the [“X2 Handling Guidelines and Installation”](#) section on page 19.

There is the option to use either a Gigabit Ethernet uplink using SFPs or two X2 (10G) uplinks. In the first case, the total bandwidth would be 48G+4G = 52G, and in the second case, the bandwidth would be 48G+20G=68G. SFP and 10-Gigabit Ethernet uplink options cannot be used simultaneously.

When two Supervisor Engine V-10GEs are present in a Catalyst 4510R or Catalyst 4507R switch, one X2 uplink is active on both the primary (active) and secondary (standby) supervisor engines by default, or two uplinks will be active in a nonredundant configuration.

Gigabit Ethernet SFP Uplink Ports

The four Gigabit Ethernet uplink ports operate in full-duplex mode only. These ports use the 1000BASE-T, 1000BASE-SX, 1000BASE-LX/LH, 1000BASE-ZX, CWDM, and DWDM small form-factor pluggables (SFPs). The SFPs have LC connectors to interface with multimode fiber (MMF) and single-mode fiber (SMF) cable. For further information on SFPs, see the [“SFP Guidelines”](#) section on page 24.

When two Supervisor Engine V-10GEs are present in a Catalyst 4510R or Catalyst 4507R switch, two SFP uplinks are active on both the primary (active) and secondary (standby) supervisor engines by default, or four uplinks will be active in a nonredundant configuration.

Ethernet Management Port

The Ethernet management port can be used (in ROMMON mode only) to recover a switch software image that has been corrupted or destroyed due to a network catastrophe. When using Cisco IOS Release 12.2(50)SG or later, this port can also perform the same functions as the console port. For earlier Cisco IOS software releases, this port is not active while the switch is operating normally.

Console Port

The Catalyst 4500 series Supervisor Engine V-10GE console port has an EIA/TIA-232 RJ-45 connector. The console port allows you to perform the following functions:

- Configure the switch from the CLI
- Monitor network statistics and errors
- Configure SNMP agent parameters

**Note**

EIA/TIA-232 was known as recommended standard RS-232 before its acceptance as a standard by the Electronic Industries Alliance (EIA) and Telecommunications Industry Association (TIA).

Reset Button

The Reset button is used to restart the switch.

**Note**

Use a paper clip or other small, pointed object to press the Reset button.

Compact Flash Port

The Flash port accepts a Type 1 compact Flash card. You can use it for file transfer tasks such as loading a new software image. The Flash card is optional and can be obtained from third-party suppliers.

For more information, refer to *Using the Compact Flash on the Catalyst 4000 Family Supervisor Engine III and IV* at the following URL:

http://www.cisco.com/en/US/docs/switches/lan/catalyst4500/hardware/configuration/notes/OL_2788.html

Port Cabling Specifications

This section provides port cabling specifications and includes the following subsections:

- [Maximum Cable Distances, page 12](#)
- [Removing the Supervisor Engine, page 12](#)

The length of your networks and the distances between connections depend on the type of signal, the signal speed, and the transmission medium (the type of cabling used to transmit the signals). The distance and rate limits in this document are the IEEE-recommended maximum speeds and distances for signaling. [Table 2](#) shows the transmission speed versus the distance.

Table 2 EIA/TIA-232 Transmission Speed in Contrast with Distance

Rate (bps)	Distance (ft)	Distance (m)
2400	200	60
4800	100	30
9600	50	15
19,200	25	7.6
38,400	12	3.7
56,000	8.6	2.6

Maximum Cable Distances

Table 3 shows the maximum cable distances for transceiver speed and cable type.

Table 3 Maximum Cable Distances

Transceiver Speed (Mbps)	Cable Type	Duplex Mode	Maximum Distance Between Stations
10	Category 3 UTP	Half or full	328 ft (100 m)
10	MMF	Half or full	1.2 mi (2 km)
100	Category 5 UTP	Half or full	328 ft (100 m)
100	MMF	Half	1312 ft (400 m)
100	MMF	Full	1.2 mi (2 km)

Removing the Supervisor Engine

All Catalyst 4500 series switches support hot swapping, which lets you install, remove, replace, and rearrange supervisor engines and switching modules without powering the system off. When the system detects that a switching module has been installed or removed, it runs diagnostic and discovery routines automatically, acknowledges the presence or absence of the module, and resumes system operation with no operator intervention.

This section contains the following subsections:

- [Required Tools, page 12](#)
- [Installing the Supervisor Engine, page 13](#)
- [Removing the Supervisor Engine, page 15](#)



Warning

Only trained and qualified personnel should be allowed to install, replace, or service this equipment.
Statement 1030



Warning

Ultimate disposal of this product should be handled according to all national laws and regulations.
Statement 1040

Required Tools

You will need these tools to install a supervisor engine in a Catalyst 4500 series switch:

- Number 1 and number 2 Phillips screwdrivers for the captive installation screws on most modules
- 3/16-in. flat-blade screwdriver for the captive installation screws on other modules
- Antistatic mat or antistatic foam
- Wrist strap or other grounding device

**Note**

Whenever you handle supervisor engines, use a wrist strap or other grounding device to prevent electrostatic discharge (ESD) damage.

Preventing Electrostatic Discharge Damage

ESD damage, which can occur when electronic cards or components are improperly handled, results in complete or intermittent failures. Port adapters and processor modules consist of printed circuit boards that are fixed in metal carriers. Electromagnetic interference (EMI) shielding and connectors are integral components of the carrier. Although the metal carrier helps to protect the board from ESD, use a preventive antistatic strap during handling.

Following are guidelines for preventing ESD damage:

- Always use an ESD wrist or ankle strap and ensure that it makes good skin contact.
- Connect the equipment end of the strap to an unfinished chassis surface.
- When installing a component, use any available ejector levers or captive installation screws to properly seat the bus connectors in the backplane or midplane. These devices prevent accidental removal, provide proper grounding for the system, and help to ensure that bus connectors are properly seated.
- When removing a component, use any available ejector levers or captive installation screws to release the bus connectors from the backplane or midplane.
- Handle carriers by available handles or edges only; avoid touching the printed circuit boards or connectors.
- Place a removed component board-side-up on an antistatic surface or in a static shielding container. If you plan to return the component to the factory, immediately place it in a static shielding container.
- Avoid contact between the printed circuit boards and clothing. The wrist strap only protects components from ESD voltages on the body; ESD voltages on clothing can still cause damage.
- Never attempt to remove the printed circuit board from the metal carrier.

**Caution**

For safety, periodically check the resistance value of the antistatic strap. The measurement should be between 1 and 10 megohm (Mohm).

Installing the Supervisor Engine

Catalyst 4500 series switches have horizontal chassis slots that are numbered from top to bottom. On the Catalyst 4503, and 4506 switches, you can install the supervisor engine only in slot 1. On the Catalyst 4507R or 4510R switch, you install the primary supervisor engine in slot 1, and you can install an optional redundant supervisor engine in slot 2.

**Warning**

Hazardous voltage or energy is present on the backplane when the system is operating. Use caution when servicing. Statement 1034



Caution

To prevent ESD damage, handle supervisor engines by the carrier edges only.

To install a supervisor engine in a Catalyst 4500 series switch, follow this procedure:

- Step 1** Take the necessary precautions to prevent ESD damage as described in the installation guide for your switch.
- Step 2** Ensure that you have enough clearance to accommodate any interface equipment that you will connect directly to the supervisor engine ports.
- Step 3** Loosen the captive installation screws that secure the switching-module filler plate or the existing supervisor engine (whichever is present) and remove it.
- Step 4** Remove the supervisor engine filler plate or the existing supervisor engine from slot 1. If a switching module filler plate was installed, save it for future use. If you are removing an existing supervisor engine, see the [“Removing the Supervisor Engine” section on page 15](#).
- Step 5** To install the new supervisor engine, grasp the switching module front panel with one hand and place your other hand under the carrier to support the supervisor engine, as shown in [Figure 2](#). Do not touch the printed circuit boards or connector pins.
- Step 6** Align the edges of the supervisor engine carrier with the slot guides on the sides of the switch chassis, as shown in [Figure 2](#).

Figure 2 Installing the Supervisor Engine in the Chassis

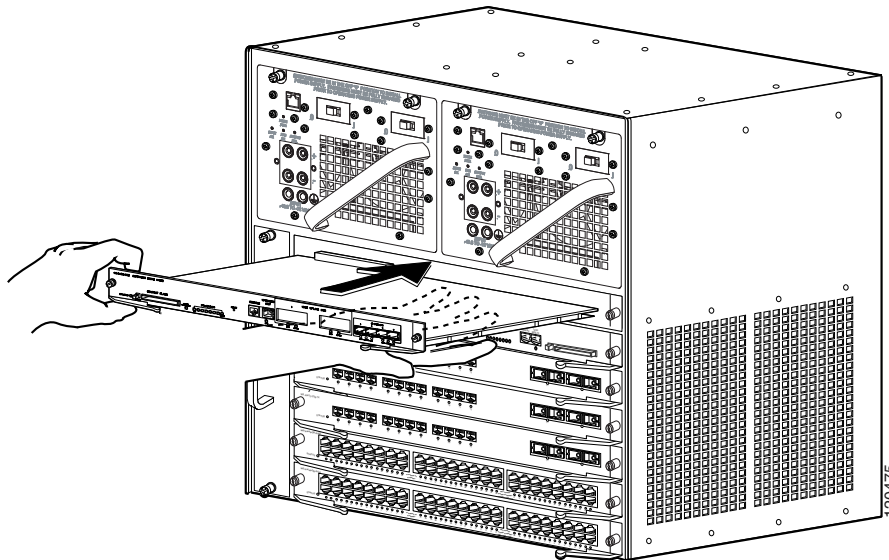

- Step 7** Pivot the two module ejector levers out and away from the faceplate.
- Step 8** Carefully slide the supervisor engine into the slot until the notches on both ejector levers engage the chassis sides.
- Step 9** Using the thumb and forefinger of each hand, simultaneously pivot in both ejector levers to fully seat the supervisor engine in the backplane connector.

**Caution**

Always use the ejector levers when installing or removing a supervisor engine. A supervisor engine that is partially seated in the backplane will not function correctly.

- Step 10** Use a screwdriver to tighten the captive installation screws on each end of the supervisor engine faceplate.

To check the status of the module, follow these steps:

- Step 1** Ensure that the LED labeled Status is green (module operational).
- Step 2** When the switch is online, enter the **show module** command. Verify that the system acknowledges the new module and that the module's status is good.
- Step 3** If the module is not operational, reseal it. If the module is still not operational, contact your customer service representative.

Removing the Supervisor Engine

**Warning**

Invisible laser radiation may be emitted from disconnected fibers or connectors. Do not stare into beams or view directly with optical instruments. Statement 1051

**Warning**

Hazardous voltage or energy is present on the backplane when the system is operating. Use caution when servicing. Statement 1034

**Caution**

To prevent ESD damage, handle supervisor engines by the carrier edges only.

To remove a supervisor engine from a Catalyst 4500 series switch, follow this procedure:

- Step 1** Disconnect any network interface cables attached to the ports on the supervisor engine that you intend to remove.
- Step 2** Loosen the captive installation screws (see [Figure 3](#)).

Figure 3 Captive Installation Screws and Ejector Levers

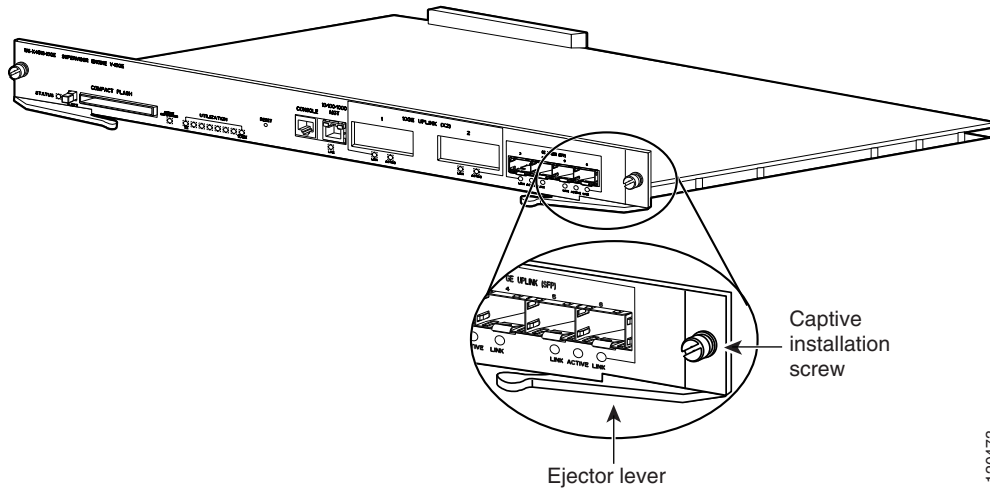

- Step 3** Grasp the left and right ejector levers and simultaneously pivot the levers outward to release the supervisor engine from the backplane connector. [Figure 3](#) shows a close-up of the right ejector lever.
- Step 4** Grasp the front panel of the supervisor engine with one hand and place your other hand under the carrier to support and guide it out of the slot. Do not touch the printed circuit boards or connector pins.
- Step 5** Carefully pull the supervisor engine straight out of the slot, keeping your other hand under the carrier to guide it.
- Step 6** Place the supervisor engine on an antistatic mat or antistatic foam, or immediately install it in another slot.



Warning

Blank faceplates and cover panels serve three important functions: they prevent exposure to hazardous voltages and currents inside the chassis; they contain electromagnetic interference (EMI) that might disrupt other equipment; and they direct the flow of cooling air through the chassis. Do not operate the system unless all cards, faceplates, front covers, and rear covers are in place.
Statement 1029

- Step 7** If the slot is to remain empty, install a switching-module filler plate (part number 800-00292-01).

Attaching Module Interface Cables

[Figure 4](#) and [Figure 5](#) show the connector types used to attach interface cables to the supervisor engine.

Figure 4 RJ-45 Connector

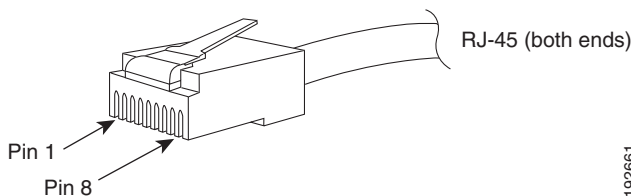

Warning

To avoid electric shock, do not connect safety extra-low voltage (SELV) circuits to telephone-network voltage (TNV) circuits. LAN ports contain SELV circuits, and WAN ports contain TNV circuits. Some LAN and WAN ports both use RJ-45 connectors. Use caution when connecting cables. Statement 1021



Note

Always keep caps and plugs on the fiber-optic connectors on the cable and the switch when they are not in use.

Warning

Invisible laser radiation may be emitted from disconnected fibers or connectors. Do not stare into beams or view directly with optical instruments. Statement 1051

Figure 5 SC-Type Fiber-Optic Connector

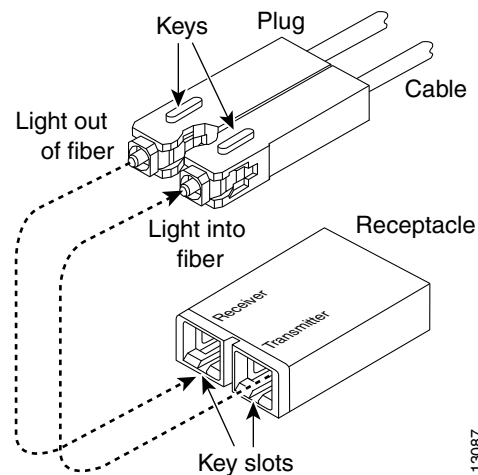

13087

SC Connector

The SC connector, shown in [Figure 6](#), is used to connect fiber-optic module ports or transceivers with the external SMF or MMF network.



Warning

Invisible laser radiation may be emitted from disconnected fibers or connectors. Do not stare into beams or view directly with optical instruments. Statement 1051

Note

Make sure that the optical connectors are clean before making the connections. Contaminated connectors can damage the fiber and cause data errors.

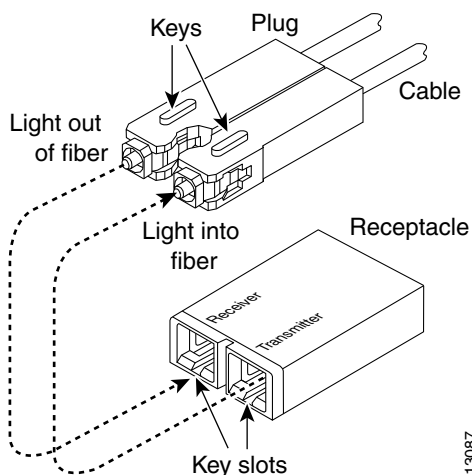
Figure 6 SC Fiber-Optic Connector



Always insert the network connector completely into the socket. A secure connection is especially important when you are establishing a connection between a module and a long distance (1.24 miles) (2 km) network or a module and a suspected highly attenuated network. If the link LED does not light, try removing the network cable plug and reinserting it firmly into the module socket. It is possible that dirt or skin oils have accumulated on the plug faceplate (around the optical-fiber openings), generating significant attenuation and reducing the optical power levels below threshold levels so that a link cannot be made.

Caution

Use extreme care when removing or installing connectors so that you do not damage the connector housing or scratch the end-face surface of the fiber. Always install protective covers on unused or disconnected components to prevent contamination. Always clean fiber connectors before installing them.

LC Connector

Warning

Invisible laser radiation may be emitted from disconnected fibers or connectors. Do not stare into beams or view directly with optical instruments. Statement 1051

The LC fiber optic connector, shown in [Figure 7](#), is a small form-factor fiber-optic connector that provides high density fiber connectivity. The LC connector can be used with either MMF cable or SMF cable. The LC connector uses a latching clip mechanism that is similar to the one used on the RJ-45 copper connector.

**Note**

Make sure that the optical connectors are clean before making the connections. Contaminated connectors can damage the fiber and cause data errors.

Figure 7 LC Fiber Optic Connector

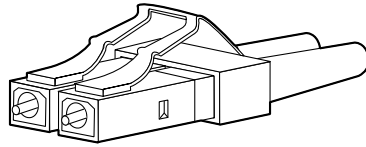

58476

Configuring Your Supervisor Engine

For information and commands to configure your supervisor engine, refer to the *Software Configuration Guide* for your switch.

X2 Handling Guidelines and Installation

An X2 transceiver (see [Figure 8](#)) is a hot swappable input/output device that plugs into the 10 Gigabit Ethernet port of the supervisor engine and links the supervisor engine with a fiber-optic network. X2 transceivers are online swappable.

Figure 8 10-Gigabit Ethernet X2 Transceiver

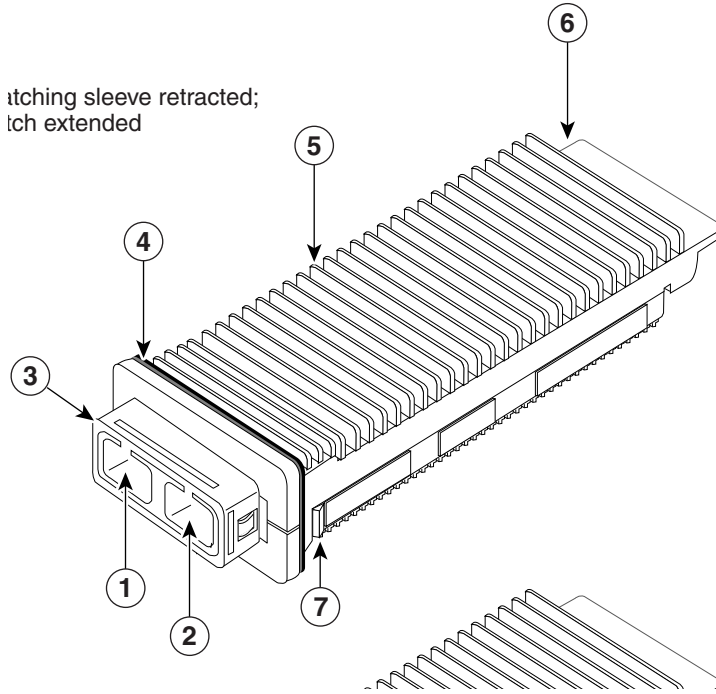

1	Transmit optical bore	4	EMI gasket
2	Receive optical bore	5	Transceiver heat sink
3	Sleeve latching mechanism	6	Module connector

Table 4 lists the specifications for the 10-Gigabit Ethernet X2 transceiver.

Table 4 X2 10-Gigabit Ethernet Transceiver Specifications

Specification	Description
Wavelength	1310 nm (1260 nm–1355 nm)
Cabling distance	Up to 10 km (6.2 miles)
Connector	SC Duplex
Mean launch power (maximum)	+0.5 dBm
Minimum sensitivity	-14.4 dBm
Dimensions	89.05 mm x 40.05 mm x 19.25 mm (3.5 in x 1.58 in x 0.76 in)

Warning

Class 1 laser product. Statement 1008

Warning

Do not stare into the beam or view it directly with optical instruments. Statement 1011

**Warning**

Use of controls, adjustments, or performing procedures other than those specified may result in hazardous radiation exposure. Statement 1057

The following transceiver media types are supported:

- 1000BASE-T (WS-G5483)
- 1000BASE-SX (WS-G5484)
- 1000BASE-LX/LH (WS-G5486)
- 1000BASE-ZX (WS-G5487)
- 10GBASE-LR (X2-10GBASE-LR)

**Caution**

Because of interoperability issues, Cisco does not support xenpaks purchased from third-party vendors.

Cisco 1000BASE-LX/LH interfaces fully comply with the IEEE 802.3z 1000BASE-LX standard. However, their higher optical quality allows them to reach 10 km over SMF cable instead of the 5 km specified in the standard.

If an LR X2 designed for operation on an SMF cable is directly coupled to an MMF cable, an effect known as Differential Mode Delay (DMD) might occur. See the *Catalyst 4000 Family Module Installation Guide* for more information.

This section describes the following topics:

- [Installing the 10-Gigabit Ethernet X2 Transceiver, page 21](#)
- [Installing the 10-Gigabit Ethernet X2 Transceiver, page 21](#)
- [X2 Transceiver Maintenance Guidelines, page 24](#)

Installing the 10-Gigabit Ethernet X2 Transceiver

**Caution**

The 10-Gigabit Ethernet X2 transceiver is a static-sensitive device. Always use an ESD wrist strap or similar individual grounding device when handling X2 transceivers or coming into contact with modules.

To install a 10-Gigabit Ethernet X2 transceiver, follow these steps:

-
- Step 1** Using a small flat-blade screwdriver, carefully pry the X2 transceiver port cover off of the module faceplate.
- Use the two arrows on the port cover as guides for inserting the screwdriver blade. Save the port cover for future use.
- Step 2** Remove the 10-Gigabit Ethernet X2 transceiver from its protective packaging.
- Step 3** Check the label on the 10-Gigabit Ethernet X2 transceiver to verify that the 10-Gigabit Ethernet X2 transceiver is the correct model for your network.
- Step 4** Grip the sides of the 10-Gigabit Ethernet X2 transceiver sleeve with your thumb and forefinger, and insert the 10-Gigabit Ethernet X2 transceiver into the X2 socket on the module front panel. You will hear a click when the X2 transceiver is approximately 90 percent installed. Continue sliding the X2

transceiver into the socket until you hear a second click. The X2 transceiver connector is now mated to the socket connector. Verify that the X2 transceiver EMI gasket is in contact with the module faceplate. (See [Figure 9](#).)



Tip

With some X2 transceivers you might need to pull out the latching sleeve as you slide the X2 transceiver into the socket. When the EMI gasket makes contact with the module faceplate, slide the latching sleeve in to secure the X2 transceiver in the socket.

Figure 9 *Installing the 10-Gigabit Ethernet X2 Transceiver*

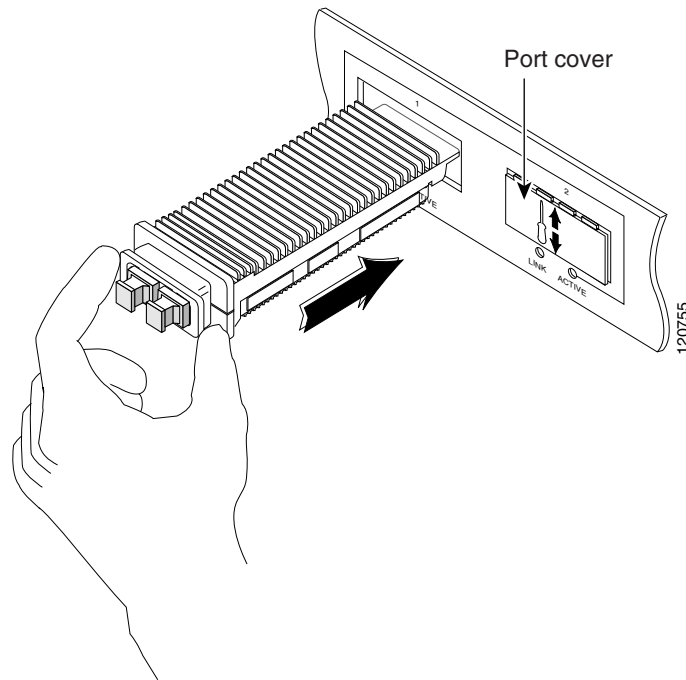

Note

10-Gigabit Ethernet X2 transceivers are keyed to prevent incorrect insertion.



Note

Before removing the dust plugs and making any optical connections, observe the following guidelines:

- Always keep the protective dust plugs on the unplugged fiber-optic cable connectors and the transceiver optical bores until you are ready to make a connection.
- Always inspect and clean the SC connector end-faces just before making any connections. Refer to the Tip on this page for a pointer to a fiber-optic inspection and cleaning white paper.
- Always grasp the SC connector housing to plug or unplug a fiber-optic cable.

Step 5 Remove the dust plugs from the network interface cable SC connectors.
Save the dust plugs for future use.

Step 6 Inspect and clean the SC connector's fiber-optic end-faces. Refer to the Tip below for a pointer to a fiber-optic inspection and cleaning white paper.

**Tip**

For complete information on inspecting and cleaning fiber-optic connections, refer to the white-paper document at this URL:

http://www.cisco.com/en/US/tech/tk482/tk876/technologies_white_paper09186a0080254eba.shtml

- Step 7** Remove the dust plugs from the 10-Gigabit Ethernet X2 transceiver optical bores.
- Step 8** Immediately attach the network interface cable SC connectors to the 10-Gigabit Ethernet X2 transceiver.

Removing the 10-Gigabit Ethernet X2 Transceiver

**Caution**

The 10-Gigabit Ethernet X2 transceiver is a static-sensitive device. Always use an ESD wrist strap or similar individual grounding device when handling X2 transceivers or coming into contact with modules.

If you are removing a 10-Gigabit Ethernet X2 transceiver, follow these steps:

- Step 1** Disconnect the network fiber-optic cable from the 10-Gigabit Ethernet X2 transceiver connectors. Immediately reinstall the dust plugs in the X2 transceiver optical bores and the fiber-optic cable SC connectors
- Step 2** Grip the sides of the 10-Gigabit Ethernet X2 transceiver sleeve with your thumb and forefinger, and pull the sleeve out to release the X2 transceiver from the socket connector. (See [Figure 10](#).)

Figure 10 Removing the 10-Gigabit Ethernet X2 Transceiver

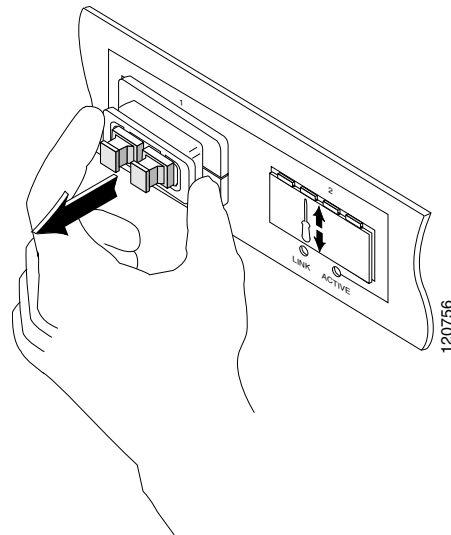

- Step 3** Slide the 10-Gigabit Ethernet X2 transceiver out of the socket and immediately place it in an antistatic bag.

- Step 4** Reinstall the socket cover if you are not installing an X2 transceiver in the empty socket.
- a. Position the socket cover in front of the socket opening.
 - b. Snap the socket cover in place.
-

X2 Transceiver Maintenance Guidelines

To properly maintain X2 transceivers, follow these guidelines:

- To prevent ESD damage, follow normal handling procedures.
- When the transceiver is stored or when a fiber-optic cable is not plugged in, always keep plugs in the optical bores.
- The most common source of contaminants in the optical bores is debris picked up on the ferrules of the optical connectors. Use an alcohol swab or Kim-Wipe to clean the ferrules of the optical connector.



Warning

Invisible laser radiation may be emitted from disconnected fibers or connectors. Do not stare into beams or view directly with optical instruments. Statement 1051

SFP Guidelines

SFP modules are hot-pluggable and field-replaceable, and you can insert them into the four SFP module slots on the front panel of the Supervisor Engine V-10GE. You can use the SFP modules for connections to other network devices.

You can use any combination of supported SFP modules. Use only Cisco SFP modules on your Cisco device. Each SFP module has an internal serial EEPROM that is encoded with security information. This encoding provides a way for Cisco to identify and validate that the SFP module meets the requirements for the device.

The following SFP media types are supported:

- 1000BASE-SX (GLC-SX-MM)
- 1000BASE-LX/LH (GLC-LH-SM)
- 1000BASE-ZX (GLC-ZX-SM)
- 1000BASE-T (GLC-T)
- CWDM (CWDM-SFP-xxxx)

Cisco 1000BASE-LX/LH interfaces fully comply with the IEEE 802.3z 1000BASE-LX standard. However, their higher optical quality allows them to reach 10 km over SMF cable instead of the 5 km specified in the standard.

If an LX/LH SFP designed for operation on an SMF cable is directly coupled to an MMF cable, an effect known as Differential Mode Delay (DMD) might occur. See the *Catalyst 4000 Family Module Installation Guide* for more information.

This section describes the following topics:

- [Fiber-Optic SFP Modules, page 25](#)

- [1000BASE-T SFP Modules, page 26](#)
- [CWDM SFPs, page 26](#)

Fiber-Optic SFP Modules

Some fiber-optic SFP modules use LC-type connectors, as shown in [Figure 11](#).



Caution

Protect your fiber-optic SFP modules by inserting clean dust plugs into the SFP modules after you remove the cables. Be sure to clean the optic surfaces of the fiber-optic cables with a soft antistatic cloth before you reconnect them to another SFP module. Avoid getting dust and other contaminants into the optical bores, as the optics do not work correctly when obstructed with dust.

Figure 11 LC Fiber-Optic SFP Module

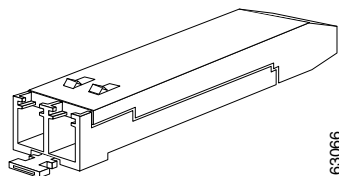

LC SFPs provide duplex single-mode and multimode connections in supported devices. [Table 5](#) lists the cable specifications for fiber-optic SFP module ports.

Table 5 Fiber-Optic SFP Module Port Cabling Specifications

SFP Module	Wavelength (nanometers)	Fiber Type	Core Size (micron)	Modal Bandwidth (MHz/km)	Cable Distance
1000BASE-SX	850	MMF	62.5	160	722 feet (220 m)
			62.5	200	902 feet (275 m)
			50.0	400	1640 feet (500 m)
			50.0	500	1804 feet (550 m)
1000BASE-LX/LH	1300	MMF ¹	62.5	500	1804 feet (550 m)
			50.0	400	1804 feet (550 m)
		SMF	50.0	500	1804 feet (550 m)
			9/10	—	32,810 feet (10 km)
1000BASE-ZX	1550	SMF	9/10	—	43.4 to 62 miles (70 to 100 km) ²

1. A mode-conditioning patch cord is required. Using an ordinary patch cord with MMF, 1000BASE-LX/LH SFP modules, and a short link distance can cause transceiver saturation, resulting in an elevated bit error rate (BER). When using the LX/LH SFP module with 62.5-micron diameter MMF, you must also install a mode-conditioning patch cord between the SFP module and the MMF cable on both the sending and receiving ends of the link. The mode-conditioning patch cord is required for link distances greater than 984 feet (300 m).
2. 1000BASE-ZX SFP modules can reach up to 100 km by using dispersion-shifted SMF or low-attenuation SMF; the distance depends on the fiber quality, the number of splices, and the connectors.

**Note**

When using shorter distances of single-mode fiber cable, you might need to insert an inline optical attenuator in the link to avoid overloading the receiver.

When the fiber-optic cable span is less than 15.43 miles (25 km), you should insert a 5-decibel (dB) or 10-dB inline optical attenuator between the fiber-optic cable plant and the receiving port on the 1000BASE-ZX SFP module at each end of the link.

Fiber-optic SFP modules also use MT-RJ connectors, as shown in [Figure 12](#).

Figure 12 MT-RJ Fiber-Optic SFP Module

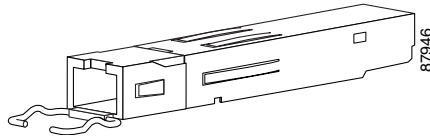

1000BASE-T SFP Modules

Copper 1000BASE-T SFP modules use RJ-45 connectors, as shown in [Figure 13](#).

Figure 13 1000BASE-T Copper SFP Module

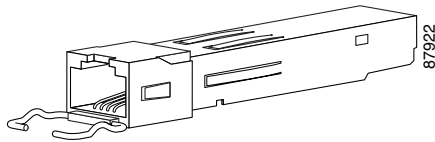

1000BASE-T copper SFP modules used with the Catalyst 4500 series Supervisor Engine V-10GE operate only in 1000BASE-T mode, or at 1000 Mbps. Copper 1000BASE-T SFP modules use standard four twisted-pair, Category 5 cable at lengths up to 328.08 feet (100 meters).

CWDM SFPs

You can connect the CWDM SFPs to CWDM passive optical system optical add/drop multiplexer (OADM) or multiplexer/demultiplexer plug-in modules using single-mode fiber-optic cables with standard SC connectors. [Figure 14](#) shows a CWDM SFP with the optical port dust plug removed. [Figure 5](#) shows an SC-type connector.

Figure 14 CWDM SFP Module (Yellow-Coded CWDM-SFP-1550= Shown)

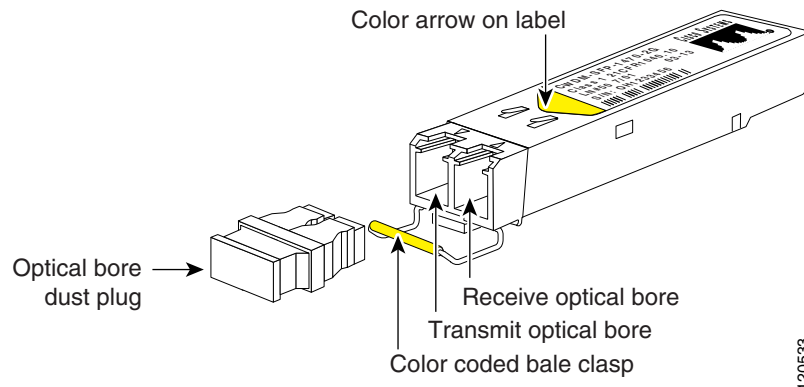
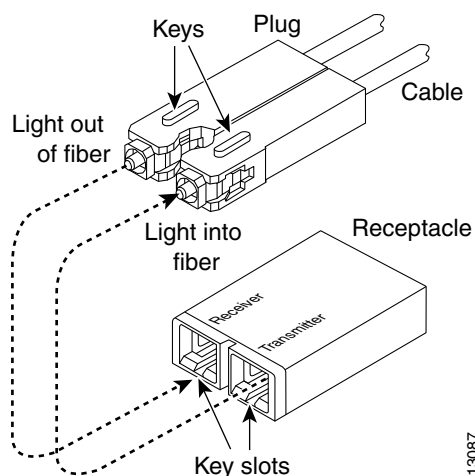

Figure 15 SC-Type Fiber-Optic Connector



CWDM SFPs come in eight wavelengths that range from 1470 nm to 1610 nm. Color markings on the devices identify the wavelength to which the Gigabit Ethernet channel is mapped. [Table 6](#) lists the CWDM SFPs with their wavelengths and color codes.

Table 6 SFP Wavelengths and Color Coding

SFP Product Number	Wavelength	Color Identifier
CWDM-SFP-1470=	Longwave 1470 nm laser, single mode	Gray
CWDM-SFP-1490=	Longwave 1490 nm laser, single mode	Violet
CWDM-SFP-1510=	Longwave 1510 nm laser, single mode	Blue
CWDM-SFP-1530=	Longwave 1530 nm laser, single mode	Green
CWDM-SFP-1550=	Longwave 1550 nm laser, single mode	Yellow
CWDM-SFP-1570=	Longwave 1570 nm laser, single mode	Orange
CWDM-SFP-1590=	Longwave 1590 nm laser, single mode	Red
CWDM-SFP-1610=	Longwave 1610 nm laser, single mode	Brown

Cleaning the Fiber Optic Connectors

Fiber optic connectors are used to connect two fibers together. When these connectors are used in a communications system, proper connection becomes a critical factor.

Fiber optic cable connectors can be damaged by improper cleaning and connection procedures. Dirty or damaged fiber optic connectors can result in communication that is not repeatable or inaccurate.

Fiber optic connectors differ from electrical or microwave connectors. In a fiber optic system, light is transmitted through an extremely small fiber core. Because fiber cores are often 62.5 microns or less in diameter, and dust particles range from a tenth of a micron to several microns in diameter, dust and any contamination at the end of the fiber core can degrade the performance of the connector interface where the two cores meet. Therefore, the connector must be precisely aligned, and the connector interface must be absolutely free of trapped foreign material.

Connector loss, or insertion loss, is a critical performance characteristic of a fiber optic connector. Return loss is also an important factor. Return loss specifies the amount of reflected light; the lower the reflection, the better the connection. The best physical contact connectors have return losses greater than -40 dB, although -20 to -30 dB is more common.

The connection quality depends on two factors: the type of connector and the proper cleaning and connection techniques. Dirty fiber connectors are a common source of light loss. Keep the connectors clean at all times, and keep the dust covers installed when the connectors are not in use.

Before installing any type of cable or connector, use a lint-free alcohol pad from a cleaning kit to clean the ferrule, the protective white tube around the fiber, and the end-face surface of the fiber.

As a general rule, whenever there is a significant, unexplained loss of light, clean the connectors.



Caution

Use extreme care when removing or installing connectors so that you do not damage the connector housing or scratch the end-face surface of the fiber. Always install protective covers on unused or disconnected components to prevent contamination. Always clean fiber connectors before installing them.

To clean the optical connectors, use a CLETOP cassette cleaner (type A for SC connectors or type B for MT-RJ connectors) and follow the product directions. If a CLETOP cassette cleaner is not available, follow these steps:

Step 1 Use a lint-free tissue soaked in 99 percent pure isopropyl alcohol to gently wipe the faceplate. Wait five seconds for the surfaces to dry, and repeat.

Step 2 Remove any residual dust from the faceplate with clean, dry, oil-free compressed air.



Warning

Invisible laser radiation may be emitted from disconnected fibers or connectors. Do not stare into beams or view directly with optical instruments. Statement 1051

Step 3 Use a magnifying glass or inspection microscope to inspect the ferrule at an angle. Do not look directly into the aperture. Repeat the process if any contamination is detected.

The connectors used inside the system have been cleaned by the manufacturer and connected to the adapters in the proper manner. The operation of the system should be error free if the customer provides clean connectors on the application side, follows the previous directions, and follows these guidelines:

- Clean the connectors using either a CLETOP cassette cleaner (Type A for SC connectors and Type B for MT-RJ connectors) or lens tissues before connecting to the adapters. Use pure alcohol to remove contamination.
- Do not clean the inside of the connector adapters.
- Do not use force or quick movements when connecting the fiber optic connectors in the adapters.
- Cover the connectors and adapters to keep the inside of the adapters or the surface of the connectors from getting dirty when you are not using the connectors or while you are cleaning the chassis.

Related Documentation

For more detailed installation and configuration information, refer to the following:

- [Catalyst 4000 Series Installation Guide](#)
- [Catalyst 4500 Series Installation Guide](#)
- [Catalyst 4000 Series Module Installation Guide](#)
- [Regulatory Compliance and Safety Information for the Catalyst 4500 Series Switches](#)
- [Software Configuration Guide](#)—Catalyst 4000 Family, Catalyst 2948G, and Catalyst 2980G Switches
- [Command Reference](#)—Catalyst 4000 Family, Catalyst 2948G, and Catalyst 2980G Switches
- [System Message Guide](#)—Catalyst 6000 Family, Catalyst 5000 Family, Catalyst 4000 Family, Catalyst 2926G Series, Catalyst 2948G, and Catalyst 2980G Switches

Obtaining Documentation and Submitting a Service Request

For information on obtaining documentation, submitting a service request, and gathering additional information, see the monthly *What's New in Cisco Product Documentation*, which also lists all new and revised Cisco technical documentation, at:

<http://www.cisco.com/en/US/docs/general/whatsnew/whatsnew.html>

Subscribe to the *What's New in Cisco Product Documentation* as a Really Simple Syndication (RSS) feed and set content to be delivered directly to your desktop using a reader application. The RSS feeds are a free service and Cisco currently supports RSS version 2.0.

This document is to be used in conjunction with the documents listed in the “[Related Documentation](#)” section.

CCDE, CCENT, Cisco Eos, Cisco Lumin, Cisco Nexus, Cisco StadiumVision, Cisco TelePresence, Cisco WebEx, the Cisco logo, DCE, and Welcome to the Human Network are trademarks; Changing the Way We Work, Live, Play, and Learn and Cisco Store are service marks; and Access Registrar, Aironet, AsyncOS, Bringing the Meeting To You, Catalyst, CCDA, CCDP, CCIE, CCIP, CCNA, CCNP, CCSP, CCVP, Cisco, the Cisco Certified Internetwork Expert logo, Cisco IOS, Cisco Press, Cisco Systems, Cisco Systems Capital, the Cisco Systems logo, Cisco Unity, Collaboration Without Limitation, EtherFast, EtherSwitch, Event Center, Fast Step, Follow Me Browsing, FormShare, GigaDrive, HomeLink, Internet Quotient, IOS, iPhone, iQuick Study, IronPort, the IronPort logo, LightStream, Linksys, MediaTone, MeetingPlace, MeetingPlace Chime Sound, MGX, Networkers, Networking Academy, Network Registrar, PCNow, PIX, PowerPanels, ProConnect, ScriptShare, SenderBase, SMARTnet, Spectrum Expert, StackWise, The Fastest Way to Increase Your Internet Quotient, TransPath, WebEx, and the WebEx logo are registered trademarks of Cisco Systems, Inc. and/or its affiliates in the United States and certain other countries.

All other trademarks mentioned in this document or website are the property of their respective owners. The use of the word partner does not imply a partnership relationship between Cisco and any other company. (0809R)

Copyright © 2004 Cisco Systems, Inc. All rights reserved.

