

Cisco TelePresence VX Clinical Assistant™

INSTALLATION AND USER GUIDE

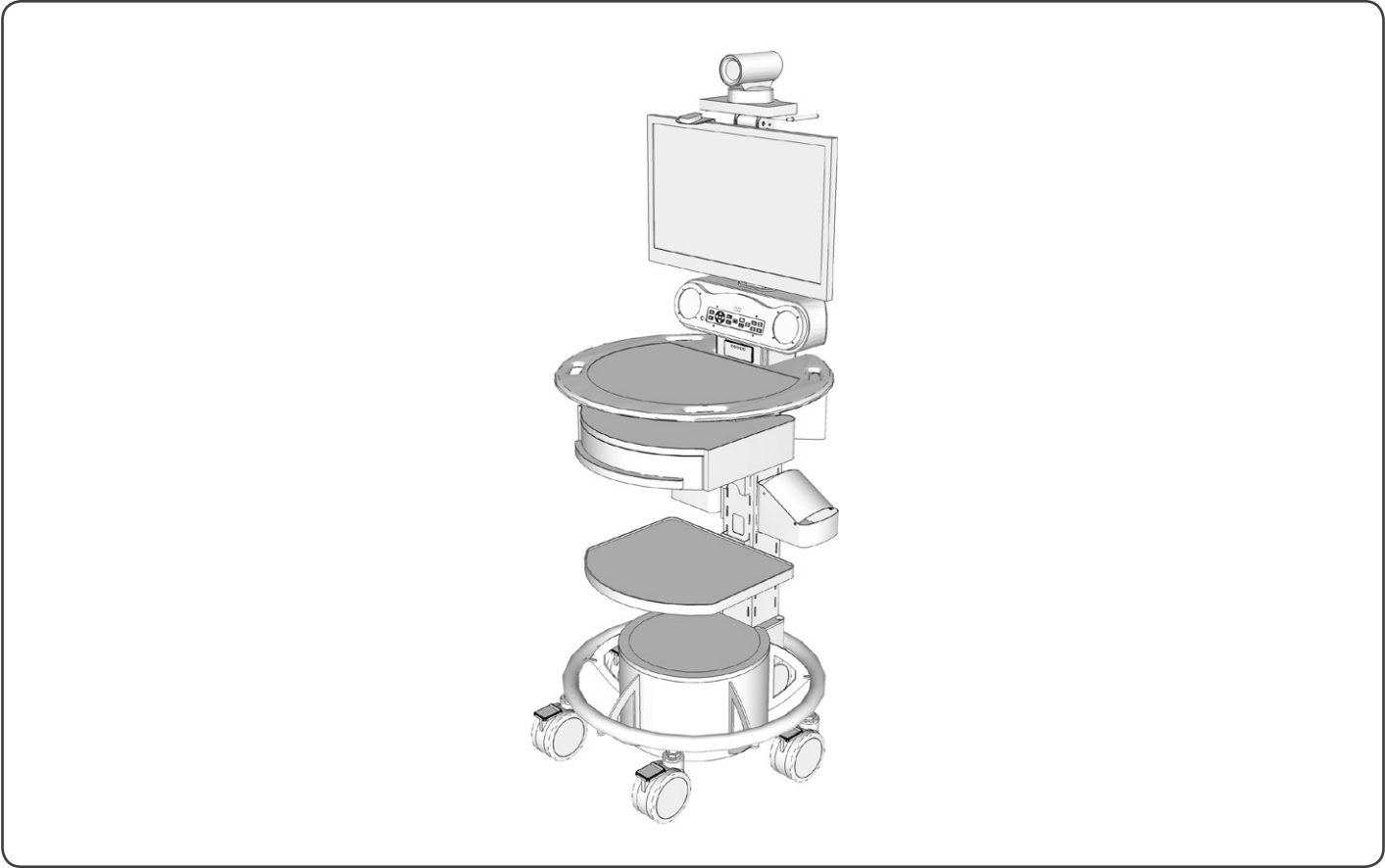

Table of Contents



What's in this guide?

For more information about configuring and using your Cisco product, refer to the following URL:

<http://www.cisco.com/go/telepresence/docs>

Contraindications	3	Installing Options	12
Introduction.....	4	Drawer Module, PC Shelf, and Storage Pods	12
Safety Precautions.....	5	Laptop Shelf	13
Warning.....	5	Scope Hooks.....	14
Environmental Issues.....	5	Wireless Mount.....	14
Waste Handling	5	Splash Cover.....	14
Important Safeguards	6	Retractable Cord Caddy.....	15
Using System in a Medical Environment.....	6	Power Schematics.....	16
Warning on Power Connection.....	6	Audio Schematics.....	17
ElectroStatic Discharge (ESD)	6	Video Schematics.....	18
Operator Safety Summary	7	Control Schematics	19
Equipment Markings	7	Using the System	20
Warnings.....	8	Turning the System On.....	20
Not Intended For Dialing Emergency Medical Services	8	Call Controls.....	21
Loss of Connectivity	8	Source Control and Rear Interface.....	22
Delay or Choppiness of Audio or Video Transmission.....	8	Headphone and Audio Input	23
Proper Training Is Required	8	Headphone Output.....	23
Camera May Not Focus	8	Audio Input.....	23
Audio Distortions	8	Cleaning the System.....	24
Tools Required for Assembly.....	9	Troubleshooting	25
System Assembly	9	Frequently Asked Questions	26
Installing the Cisco PrecisionHD Camera.....	10	Technical Specifications	27
Installing the Rechargeable Battery.....	11	Electromagnetic Emissions and Immunity Summary	28

Indications for Use



The Cisco TelePresence VX Clinical Assistant™ (VX Clinical Assistant) enables secure and effective audio/video communication between multiple healthcare providers and between providers and patients. The system transmits real-time audio and video captured by a high-definition camera and integrated microphone. It also receives real-time audio and video from a corresponding functionally like system in a remote location. Finally, the VX Clinical Assistant supports transmission of real-time audio and video from peripheral audio/visual medical devices, which may be connected to standard audio and video inputs provided on the system.

The VX Clinical Assistant is intended to facilitate remote provider/patient and provider/provider consultations. These consultations should always be conducted with a licensed medical professional physically in the room with the patient.

Contraindications

The VX Clinical Assistant is not intended to substitute for the in-person physical examination of a patient or as a substitute for direct medical intervention. It is also not intended for real-time, active, or online patient monitoring, nor is it intended to provide time sensitive data or alarms. The VX Clinical Assistant does not support transmission of numerical telemetric/serial data and is not intended for use with non-audio/visual medical devices.



Introduction



The VX Clinical Assistant brings the power of telepresence to healthcare environments. Designed for mobility and ease of use at the point of care, the VX Clinical Assistant is a high-definition video collaboration system with functionality that facilitates medical use cases ranging from remote patient consultations to virtual care teams and medical education. This mobile telemedicine endpoint is part of the Cisco TelePresence portfolio, which offers a total solution approach including content sharing, recording, firewall traversal, and management capabilities. With the VX Clinical Assistant healthcare providers can overcome the barrier of distance and work more productively through remote face-to-face collaboration in a medical setting.

Key Features of VX Clinical Assistant:

- Lightweight and highly mobile with integrated industrial design to maximize durability and functionality in a medical environment
- Cisco TelePresence C-Series codec featuring 1080p30 video, full-duplex audio, and high-definition (HD) content sharing
- 1080p HD camera with full pan-tilt-zoom (PTZ) capability - 4x zoom standard, 12x zoom optional
- 24-inch 1080p HD LED backlit display
- Tactile control panel offering simple system control with minimal training, plus infrared remote control for full untethered system operation
- Both AC and rechargeable battery power through medical-grade isolation transformer
- Flexible range of storage module options for computers, medical devices, supplies, etc.
- Five 5-inch hospital-grade, antistatic free running castors with foot locks

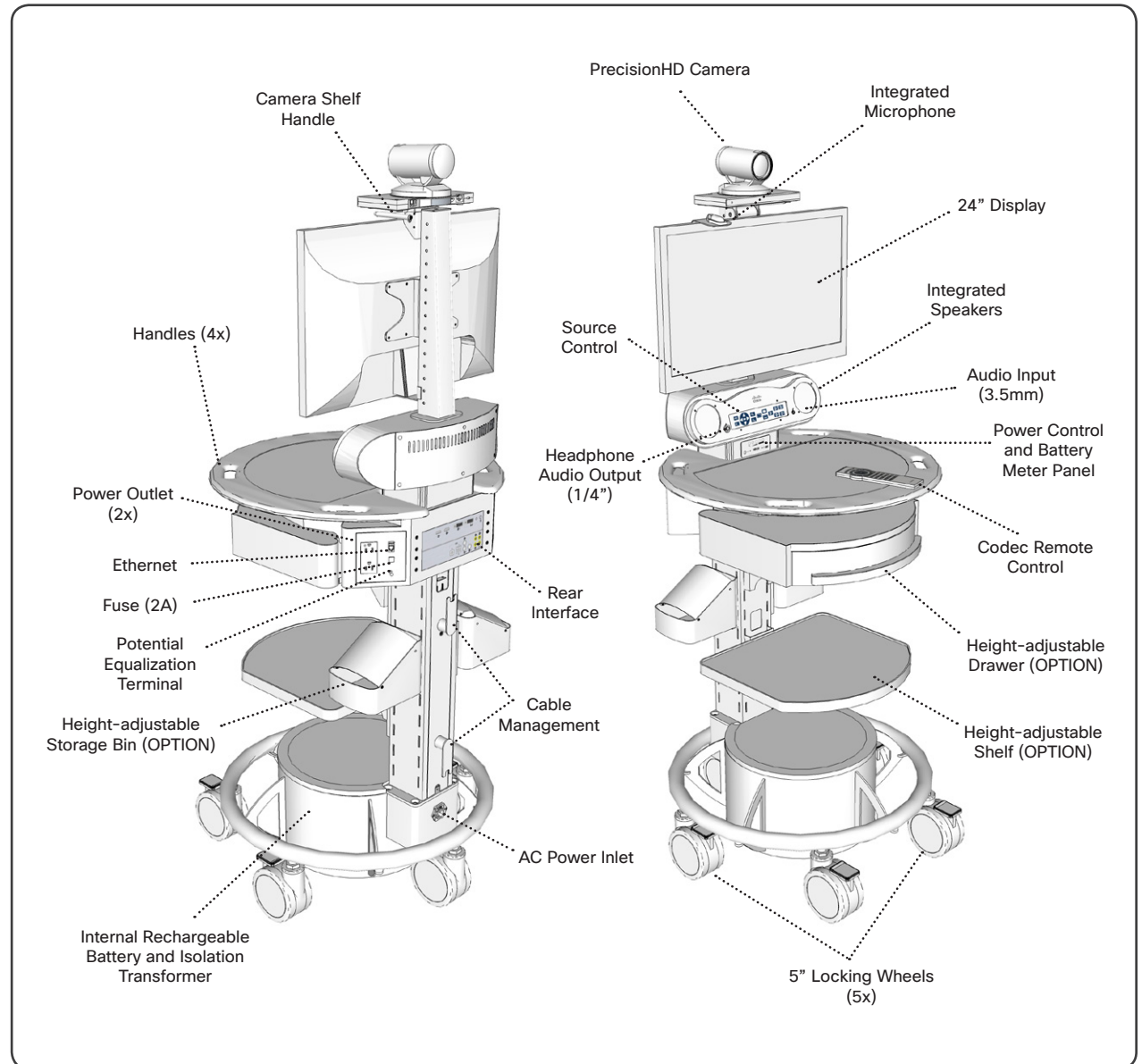

Warning

Precaution should be taken during transportation of the system. It is recommended that the operator use caution when wheeling the unit over doorstops and/or into elevators to ensure their safety and prevent damage to the unit.

For Customers In North America

This equipment complies to the limits for a Class A digital device, pursuant to Part 15 of the FCC Rules.

These limits are designed to provide reasonable protection against harmful interference when the equipment is operated in a commercial environment. This equipment generates, uses, and can radiate radio frequency energy, which may cause harmful interference to radio communications.

You are cautioned that any changes or modifications not expressly approved in this manual could void your authority to operate this equipment

Environmental Issues

Thank you for buying a product, which contributes to a reduction in pollution, and thereby helps save the environment. Our products reduce the need for travel and transport and thereby reduce pollution. Our products have either none or few consumable parts (chemicals, toner, gas, paper). Our products are low energy consuming products.

Battery handling

Batteries for the Remote Control are Long Life Alkaline batteries; please follow guidelines on the packing material for handling and disposal of the batteries.

The system enclosed battery (rechargeable battery for wireless use) in this product is non-user replaceable and should be removed by a service technician only.

CAUTION
RISK OF EXPLOSION IF BATTERY IS REPLACED BY AN INCORRECT TYPE. DISPOSE OF USED BATTERIES ACCORDING TO MANUFACTURER INSTRUCTIONS.

Production of Products

Our factories employ efficient environmental methods for reducing waste and pollution and ensuring the products are recyclable.

Waste Handling

EU Battery and WEEE Directives

Your Cisco product may contain a user replaceable battery or a permanently affixed battery as indicated in the user manual. For product safety and data integrity reasons a permanently affixed battery should only be removed or replaced professionally by a repair technician or waste management professional. Please contact Cisco or an authorized service agent if the product fails to perform due to malfunction of the permanently affixed battery.



This symbol on a Cisco product, battery or packaging means that the product and/or battery should not be disposed of with your household waste.

It is your responsibility to dispose of your waste equipment and batteries separately from your household waste and in accordance with local laws and regulations. The correct disposal of your old equipment and batteries will help prevent potential negative consequences for the environment and human health.

Please use the nearest waste collection facility as directed by your municipality or your retailer.

Important Safeguards



Using System in a Medical Environment

No currently available technology can completely substitute for the in-person physical examination of an individual patient. Cisco Telepresence products have the ability to provide high quality audio/high resolution video over long distances; and when used properly, these products can provide tools for physicians and other medical professionals who are unable to examine a patient in person. The use and value of the system will vary depending on the specific circumstances of the patient's condition, transmission speed and the ability of audio/visual technology to be used for remote evaluations. Ultimately, judgments on how this tool should be used must be at the individual discretion of the physician or other medical personnel supervising the patient's care.

All the equipment connected to this system shall be certified according to UL Standard UL60601-1 or other IEC/ISO/CSA Standards applicable to the equipment.

When this system is used together with other equipment in the patient area*, the equipment shall be either powered by an isolation transformer or connected to the power outlet that is at the rear of the cart, unless it is certified according to UL Standard UL60601-1.

NOTE: The power outlet provided in the system is powered from an isolation transformer. The maximum output rating of this outlet is 150 Watts.

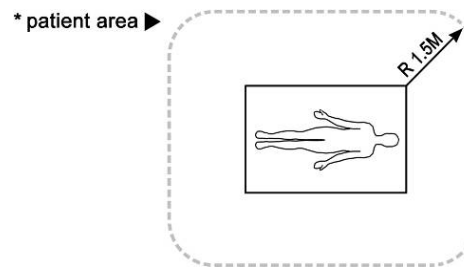

CAUTION:

The leakage current could increase when connected to other equipment.

The operator should take precautions to avoid touching the rear panel input and output circuitry and the patient at the same time.

To isolate the system from the mains supply remove the mains plug from the wall socket.

Warning on Power Connection

Use only with the supplied power cords or cords that meet local hospital-grade requirements. Users in the United States and Canada should use hospital-grade cords that meet the following requirements:

	United States	Canada
Plug Type	Hospital Grade	Hospital Grade
Cord Type	SJT3 x 18 AWG	SJT3 x 18 AWG
Minimum Cord Det Rating	10A/125V	10A/125V
Safety Approval	CSA NRTLus	CSA

NEVER USE AN EXTENSION CABLE TO POWER THE SYSTEM.

Wireless Access Point Compliance

Any customer-supplied Wireless Access Point used with the VX Clinical Assistant must comply with appropriate regulations in the country of use.

ElectroStatic Discharge (ESD)

When subjected to an electrostatic discharge the 12x system camera image may suffer momentary interruption - this will self-recover in a few seconds after the discharge.

Operator Safety Summary



For your protection, please read these safety instructions completely before operating the equipment and keep this manual for future reference. The information in this summary is intended for persons who operate the equipment as well as repair (servicing) personnel. Carefully observe all warnings, precautions and instructions on the apparatus, or the ones described in the operating instructions and adhere to them.

Also, adhere to safety guidelines found in manuals for any peripheral equipment. For your protection, the instruction manual for the LCD display is provided.

Equipment Markings



The “exclamation mark” within an equilateral triangle is intended to alert the user to the presence of important operating and maintenance (servicing) instructions within literature accompanying the equipment.



Potential Equalization Terminal



Manufacturer

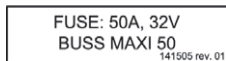
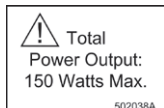

- Water and moisture - Do not operate the equipment under or near water - for example near a bathtub, kitchen sink, or laundry tub, in a wet basement, or near a swimming pool or in areas with high humidity.
- Cleaning - Unplug the apparatus from the wall outlet before cleaning or polishing. Please adhere to the general cleaning guidelines found in this document’s section: “Cleaning the System.”
- Ventilation - Do not block any of the ventilation openings of the apparatus. Install in accordance with the installation instructions. Never cover the slots and openings with a cloth or other material. Never install the apparatus near heat sources such as radiators, heat registers, stoves, or other apparatus (including amplifiers) that produce heat.
- Grounding- This equipment must be grounded. Never defeat the ground conductor or operate the equipment in the absence of a suitably installed ground conductor. Contact the appropriate electrical inspection authority or an electrician if you are uncertain that suitable grounding is available.
- Power-Cord Protection - Route the power cord so as to avoid it being walked on or pinched by items placed upon or against it, paying particular attention to the plugs, receptacles, and the point where the cord exits from the apparatus.
- Attachments - Only use attachments as recommended by the manufacturer.
- Accessories - Use only with a cart, stand, tripod, bracket, or table specified by the manufacturer, or sold with the apparatus. When a cart is used, use caution when moving the cart/apparatus combination to avoid injury from tip-over.
- Lightning - Unplug this apparatus during lightning storms or when unused for long periods of time.
- Servicing - Do not attempt to service the apparatus yourself as opening or removing covers may expose you to dangerous voltages or other hazards, and will void the warranty. Refer all servicing to qualified service personnel.
- Storage - If you need to store the system, ensure that it is stored in a controlled environment to avoid damage. Refer to the codec documentation for further guidelines.
- Repacking - Do not throw away the carton and packing materials. They make for an ideal container with which to transport the system.
- Mobility - Before moving the system unplug the power cord and securely wrap them around the cable wrap brackets. Unplug connected microphone(s) and carry separately. To move the cart, use one or more of the cart handles. You may use the camera tilt handle for local repositioning of the cart.
- Damaged Equipment - Unplug the apparatus from the outlet and refer servicing to qualified personnel under the following conditions:
 - When the power cord or plug is damaged or frayed
 - If liquid has been spilled or objects have fallen into the apparatus
 - If the apparatus has been exposed to rain or moisture
 - If the apparatus has been subjected to excessive shock by being dropped, or the unit has been damaged
 - If the apparatus fails to operate in accordance with the operating instructions.

Not Intended For Dialing Emergency Medical Services

The VX Clinical Assistant is not intended to make emergency calls. In the event of an emergency, the user should use a telephone or device other than the Cisco Telepresence VX Clinical Assistant™ to call local emergency services

Loss of Connectivity

During the use of the VX Clinical Assistant, a healthcare professional may lose connectivity with the system. Loss of connectivity can result from power outages, network outages, failure in the VX Clinical Assistant software/hardware, or other causes. Loss of connectivity can prevent a health care professional from completing a patient session in a timely manner. In cases where time is critical, the user should not use the VX Clinical Assistant and seek an in-person examination from a licensed health care professional.

Delay or Choppiness of Audio or Video Transmission

The VX Clinical Assistant may operate at a delay of up to 150 milliseconds, depending on network condition. This means that the provider may experience the audio and video transmissions later than they are really occurring. In cases where the remote health care provider needs to make time sensitive assessments or give instructions this delay may result in misalignment of audio and visual transmissions to the real-time procedure and/or inappropriate treatment or diagnosis.

Proper Training Is Required

Healthcare professionals using the VX Clinical Assistant should be sufficiently trained and familiar with the Installation and User Guide and the instructions for use. Please refer to the Cisco Telepresence VX Clinical Assistant™ Installation and User Guide (under “Troubleshooting & Frequently Asked Questions,” “Safety Precautions” and “Operator Safety Precaution.” See http://www.cisco.com/en/US/products/ps11417/tsd_products_support_install_and_upgrade.html.

Camera May Not Focus

There may be times when the system’s main camera or a connected peripheral camera does not focus or loses focus. This problem can result from equipment malfunction, improper use of the camera, improper configuration, or other reasons. An improperly configured or poorly focused camera may reduce the quality of the image. The camera can be maximized on the inputs on frame rate and resolution. Please refer to the Cisco TelePresence System Codec C Series “Getting Started Guide” at http://www.cisco.com/en/US/products/ps11422/prod_installation_guides_list.html.

Audio Distortions

The VX Clinical Assistant can experience audio distortions due to network latency, software/hardware malfunction, insufficient bandwidth, or for other reasons. If audio is not of sufficient quality for the intended use of the VX Clinical Assistant, please refer to the Cisco Telepresence VX Clinical Assistant™ Installation and User Guide (under “Source Controls,” “Technical Specifications,” and “Troubleshooting & Frequently Asked Questions.” See http://www.cisco.com/en/US/products/ps11417/tsd_products_support_install_and_upgrade.html.

System Assembly



The VX Clinical Assistant™ comes fully assembled with the exception of the Cisco PrecisionHD Camera, any optional accessories, and some cable connections.

- Cisco PrecisionHD Camera (4x or 12x option)
- Rechargeable Battery

OPTIONS:

- Drawer (lockable option)
- PC shelf
- Laptop tray
- Storage pod
- Retractable cord caddy
- Scope hooks (2)
- Splash cover
- Wireless mount

Tools Required for Assembly

There are no tools required for the base cart configuration.

A Phillips Screwdriver will be needed for installing optional accessories.

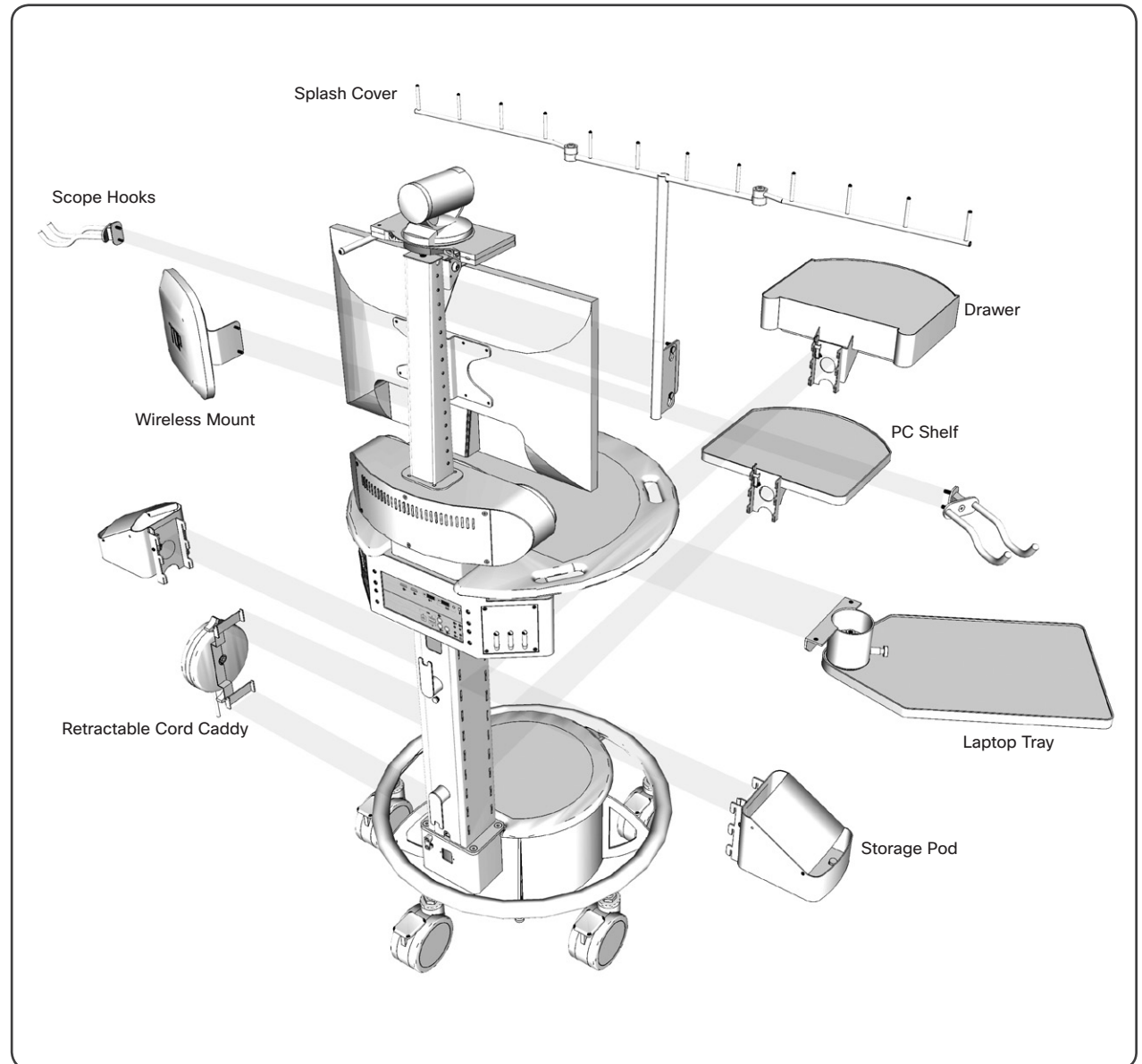

Installing the Cisco PrecisionHD Camera



1. Dismount the DISPLAY. Remove the screws (4x) from the DISPLAY BRACKET.
2. Remove the COVER PLATE under the CAMERA SHELF by unscrewing the hex screw.
3. Secure the PRECISIONHD CAMERA to the CAMERA SHELF using a 1/4-20 X 3/8" FLATHEAD PHILLIPS SCREW.
4. Replace the COVER PLATE and the DISPLAY.
5. Connect the CAMERA CABLES -- bundled and loomed to the MOUNTING COLUMN -- to the back of the PRECISIONHD CAMERA:
 - a. HDMI VIDEO OUT
 - b. CAMERA CONTROL

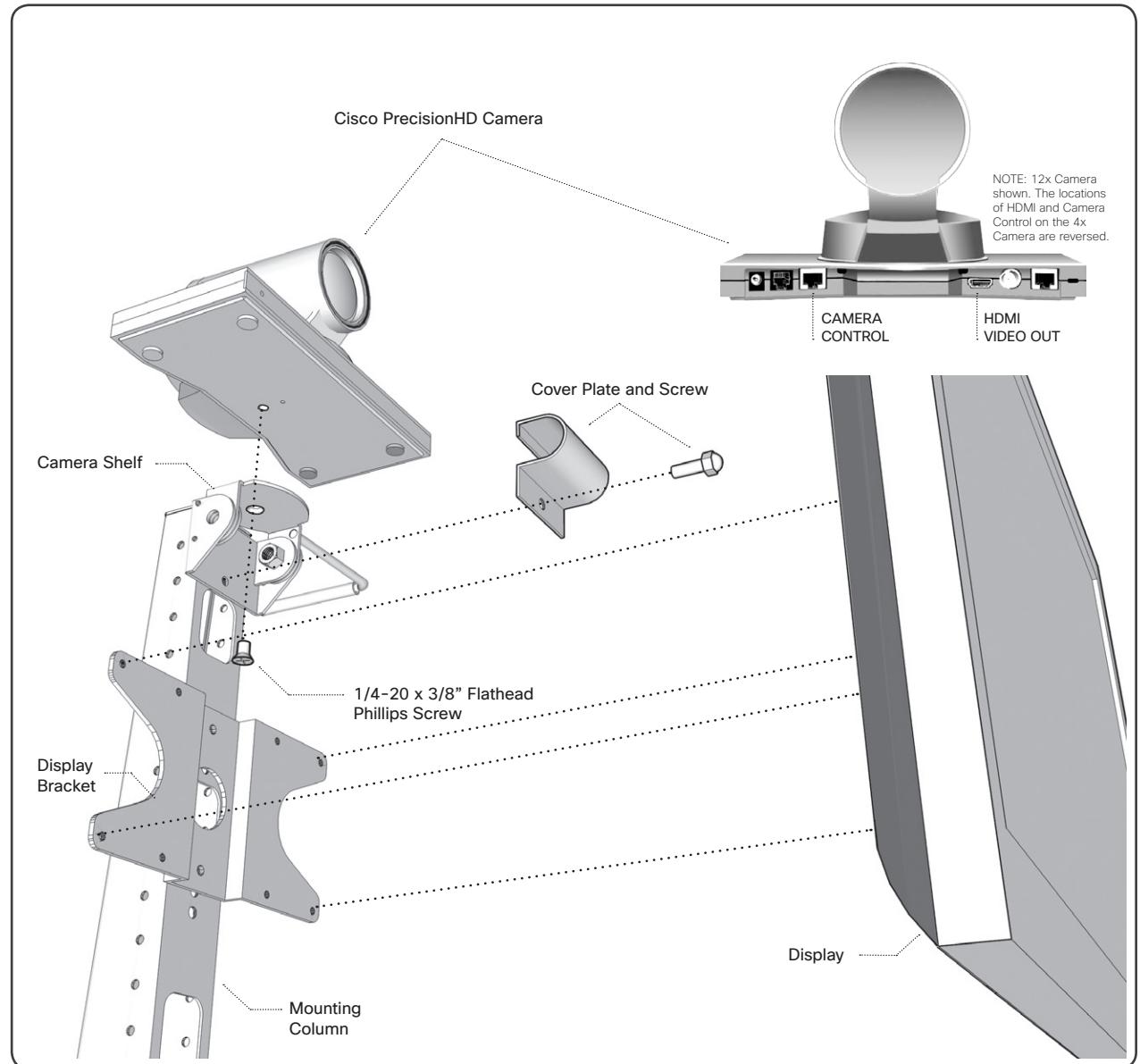

Installing the Rechargeable Battery



The system's rechargeable battery is disconnected for shipping and must be connected for proper operation.

1. Remove the ACCESS PANEL on the lower column by unscrewing the THUMBSCREW (1) near the top of the plate.
2. Remove the WING NUT (1) holding the BASE PLATE in place.
3. Remove the BASE PLATE by gently pulling the plate forward and then up.
4. Locate the YELLOW BATTERY CONNECTOR that extends from the battery and plug into the POWER SUPPLY UNIT.
5. Replace the BASE PLATE and the ACCESS PANEL.

If the BATTERY has enough charge, then the VX Clinical Assistant is ready to be configured and begin making calls.

If the BATTERY does not have enough charge, provide power by plugging the system into an appropriate outlet (120V or 240V) -- this charges the BATTERY while powering the system with AC power.

It is recommended that the unit is initially charged 4-6 hours or until the batter meter indicates a full charge.

Make sure the display is ON if it has not turned on automatically.

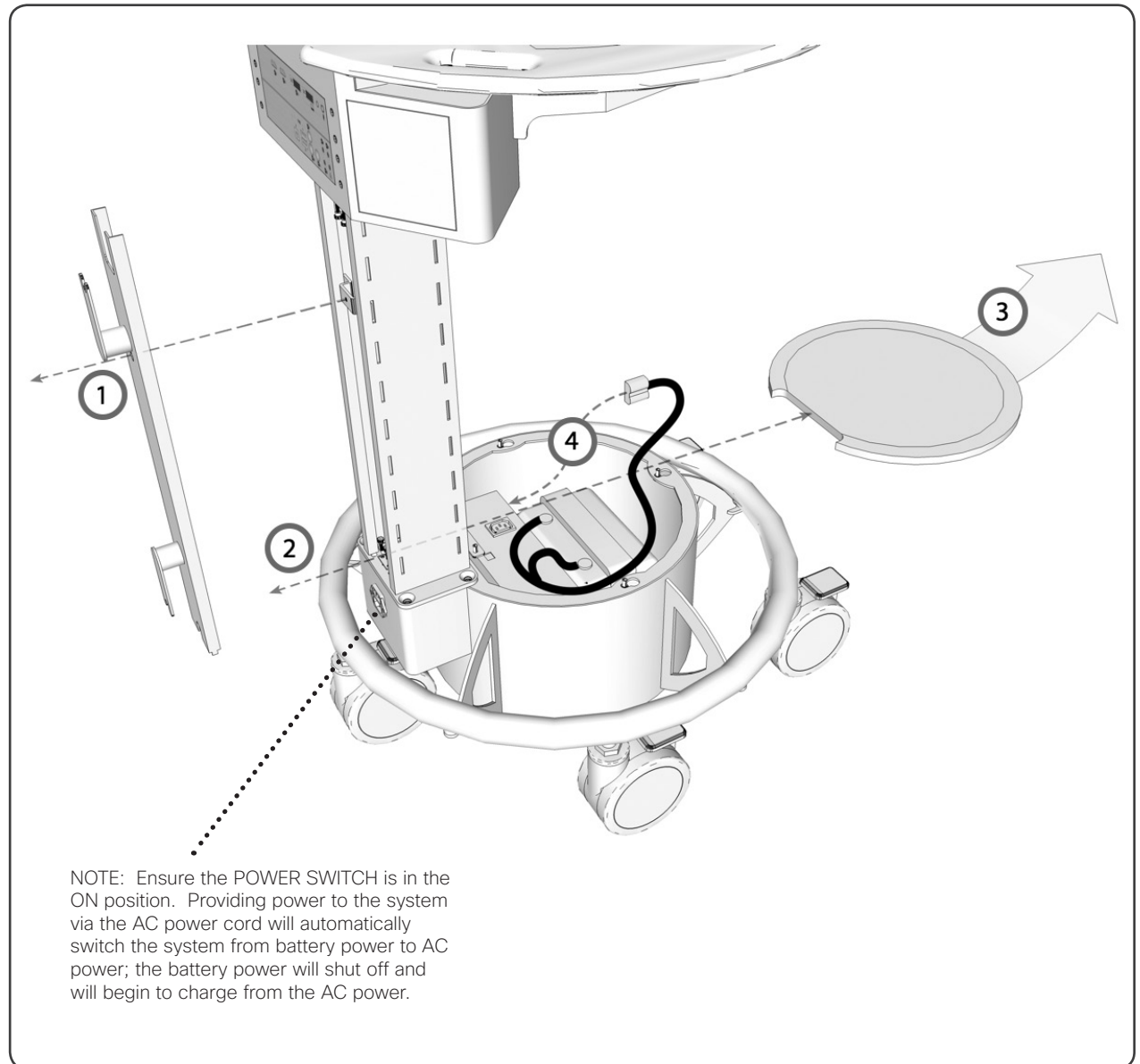

Installing Options



The following describes how the storage options are installed. While some items are easily installed without the need for any tools, there are some that will require a screwdriver and minor assembly.

Drawer Module, PC Shelf, and Storage Pods

Determine the desired location(s) of the optional DRAWER, SHELVES, or BINS.

- Align and insert the set of hooks to the SUPPORT COLUMN.
- Slide in
- Press down
- Verify locking mechanism on the upper-right hook of the accessory has “clicked” in place.

TO REMOVE an accessory:

- PULL and HOLD the locking mechanism on the upper-right hook of the accessory
- LIFT and PULL the accessory away from the column.

MAXIMUM WEIGHT CONSIDERATIONS

Locking Drawer: 15lbs / 6.8kg
Laptop Tray: 8lbs / 3.6kg
PC Shelf: 10lbs / 4.5kg
Storage Pod: 5lbs / 2.3kg
Scope Hook: 3lbs / 1.3kg

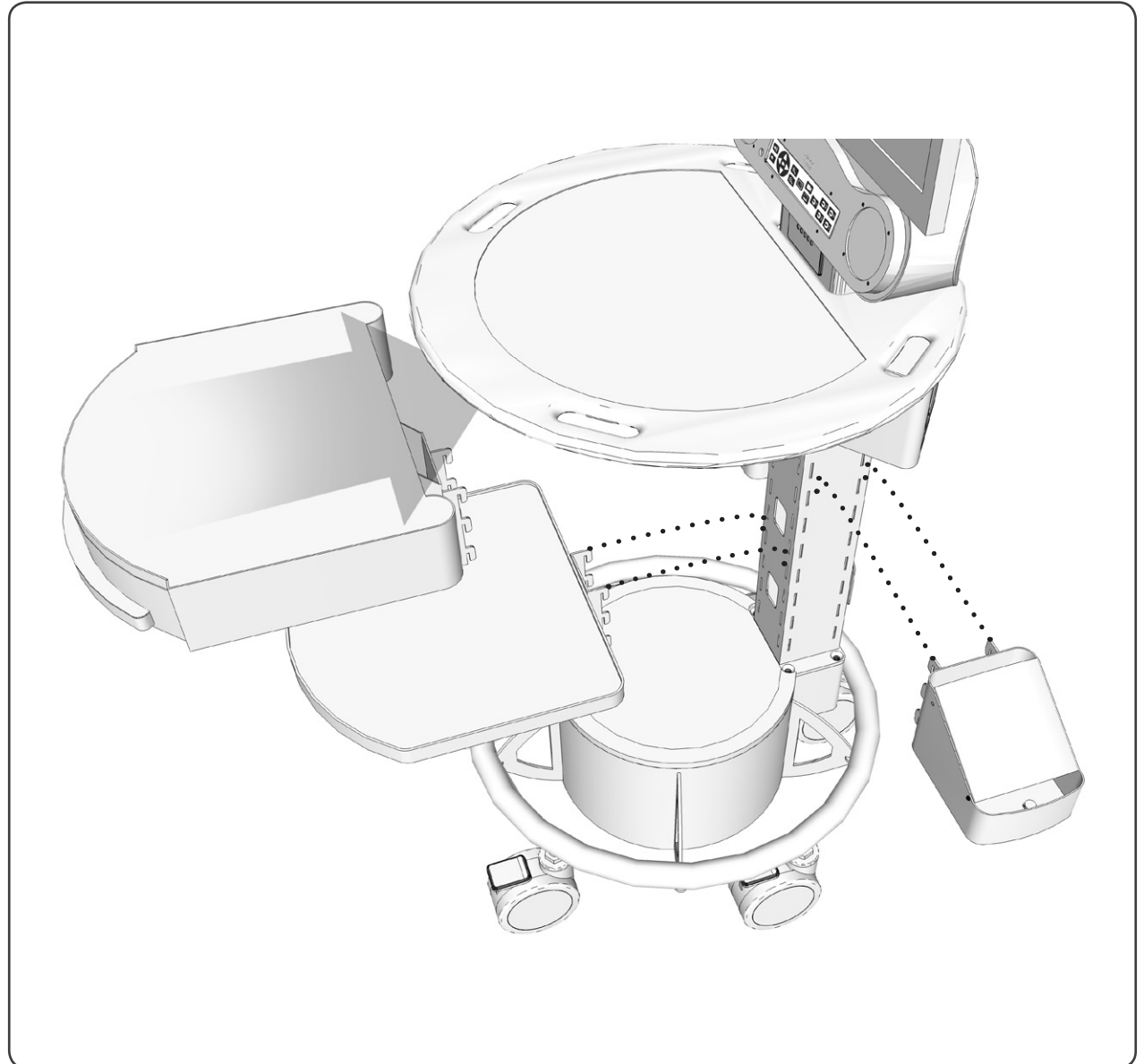

Installing Options



Laptop Shelf

1. Remove the WORK SURFACE

- Unscrew the screw at bottom of WORK SURFACE
- Lift and pull the WORK SURFACE from the system to remove.
- Flip the codec up -- to gain access to the side holes for mounting the shelf -- by removing the small Phillips screw at the bottom of the codec shelf.

2. Mount the LAPTOP SHELF to the system with the supplied screws (4) as shown.

To operate the LAPTOP SHELF, while pulling the knob to release the tray's locking mechanism, swing the tray to lock in the closed position (under the work surface) or in the extended position.

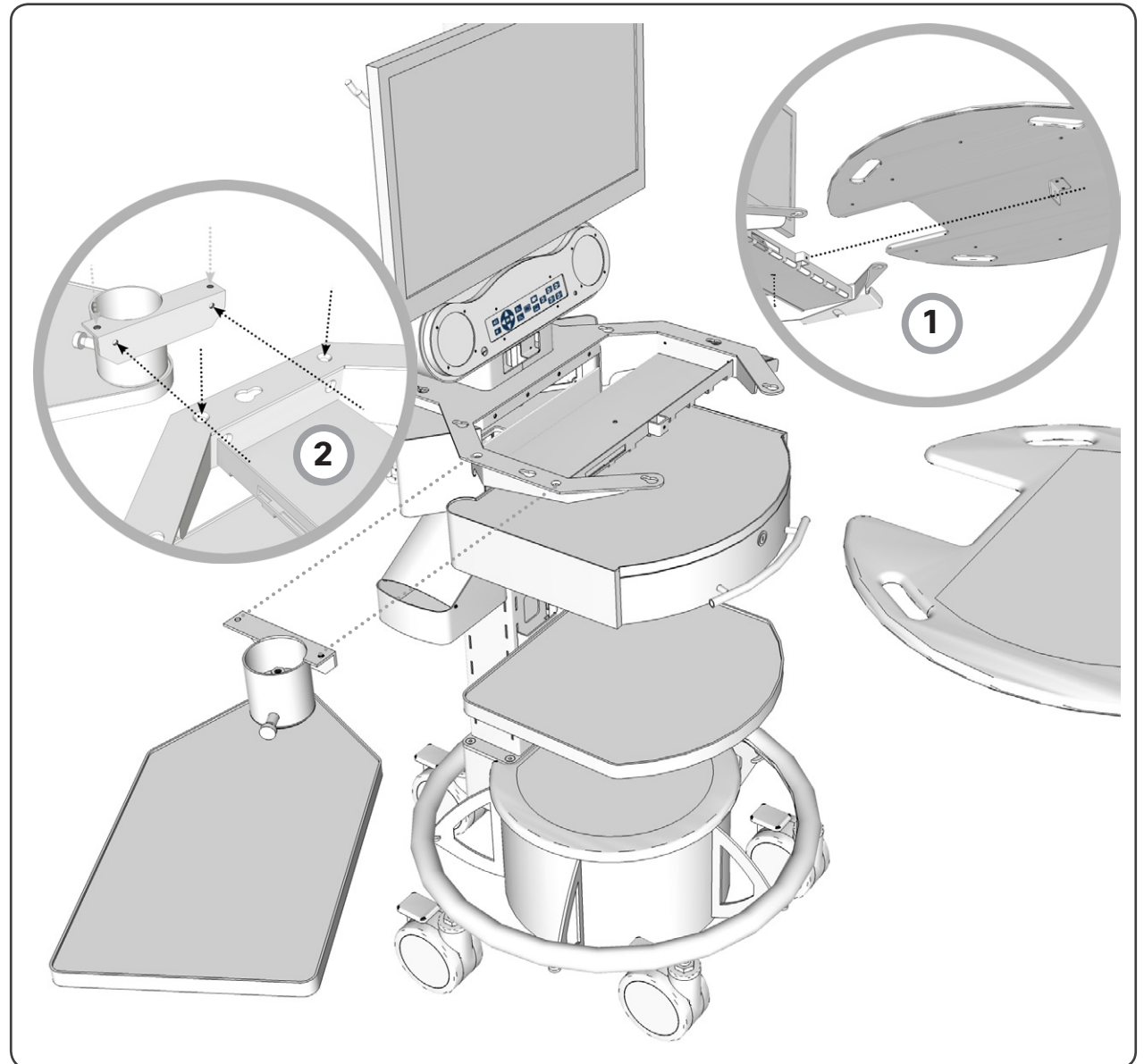
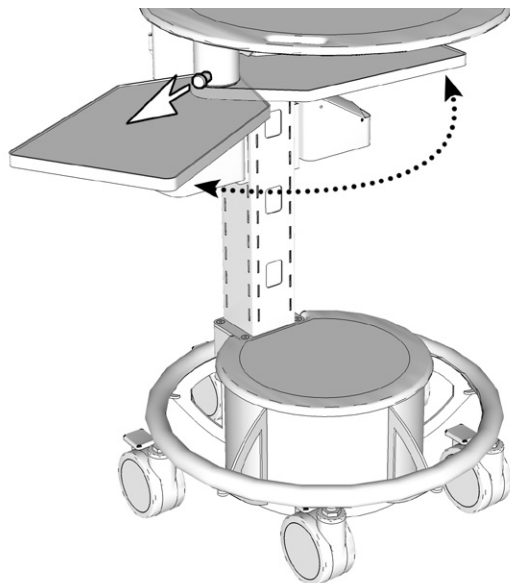

Installing Options



To properly mount the optional SCOPE HOOKS, WIRELESS MOUNT, and SPLASH GUARD, remove the BACK PANEL of the MONITOR SUPPORT COLUMN by removing the THUMB SCREW located at the top of the support column. This provides access to mount the options.

Each of these options are installed using the provided WINGNUTS.

Replace the BACK PANEL when finished.

Scope Hooks

Use the provided WINGNUTS to mount the scope hooks to the column as shown.

Wireless Mount

Mount the WIRELESS MOUNTING BRACKET to the column using the provided WINGNUTS.

Secure the Cisco Aironet Wireless Access Point (AP1040/1140 Series) to the mounting bracket, as shown, by aligning the mounting pegs to the bracket.

Splash Cover

Mount the splash cover's BRACKET to the MONITOR SUPPORT COLUMN with the provided WINGNUTS.

Secure the SPLASH COVER to the BRACKET.

Hang the transparent, plastic guard, as needed, onto the posts atop the SPLASH COVER.

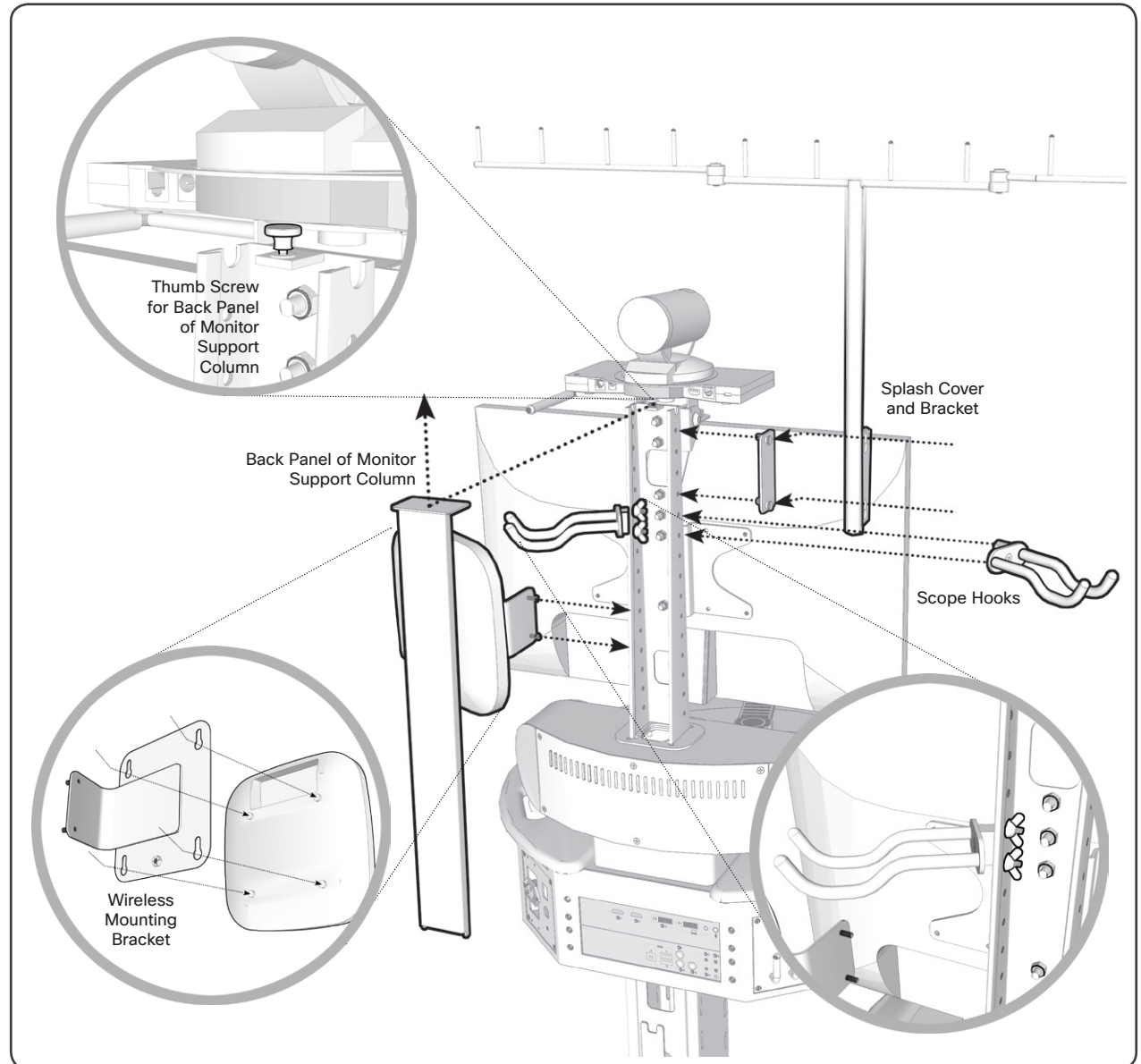

Installing Options



Retractable Cord Caddy

This option is available for North America ONLY.

1. Insert the MOUNTING BRACKETS to the side of the SUPPORT COLUMN as shown.
2. Position the RETRACTOR HOUSING to fit the flanges over the screws of the MOUNTING BRACKETS.
3. Secure the RETRACTOR HOUSING with the FASTENING KNOBS.
4. Remove the existing power cord by unscrewing the CORD STRAIN RELIEF.

Plug the power cord from the rear of the RETRACTOR HOUSING into the base of the system.

5. Secure the CORD STRAIN RELIEF over the power cord with an appropriate amount of slack.
6. Pull and plug the retractable cable into an appropriate outlet to provide AC power to the system.

To retract the power cord, unplug from outlet, gently tug to cable to retract into the housing.

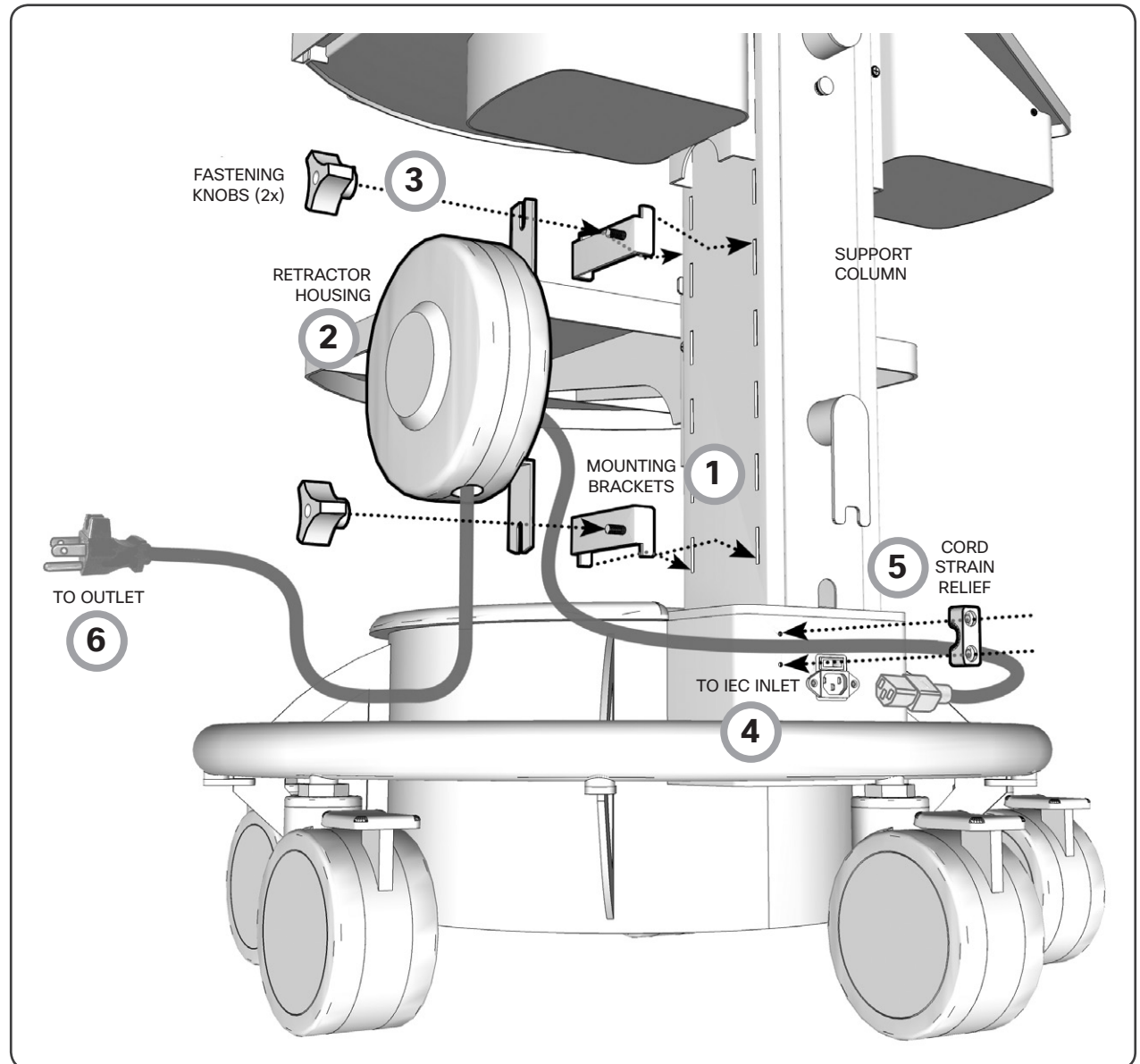

Power Schematics



Power Schematics

Audio Schematics

Video Schematics

Control Schematics

NOTES:

- 1 ⚠️ CIRCUIT BREAKER = 2AMP FOR 115VAC
CIRCUIT BREAKER = 1AMP FOR 230VAC
- 2 ⚠️ FOR 120V USE HC350SR
FOR 240V USE HCINT350SR

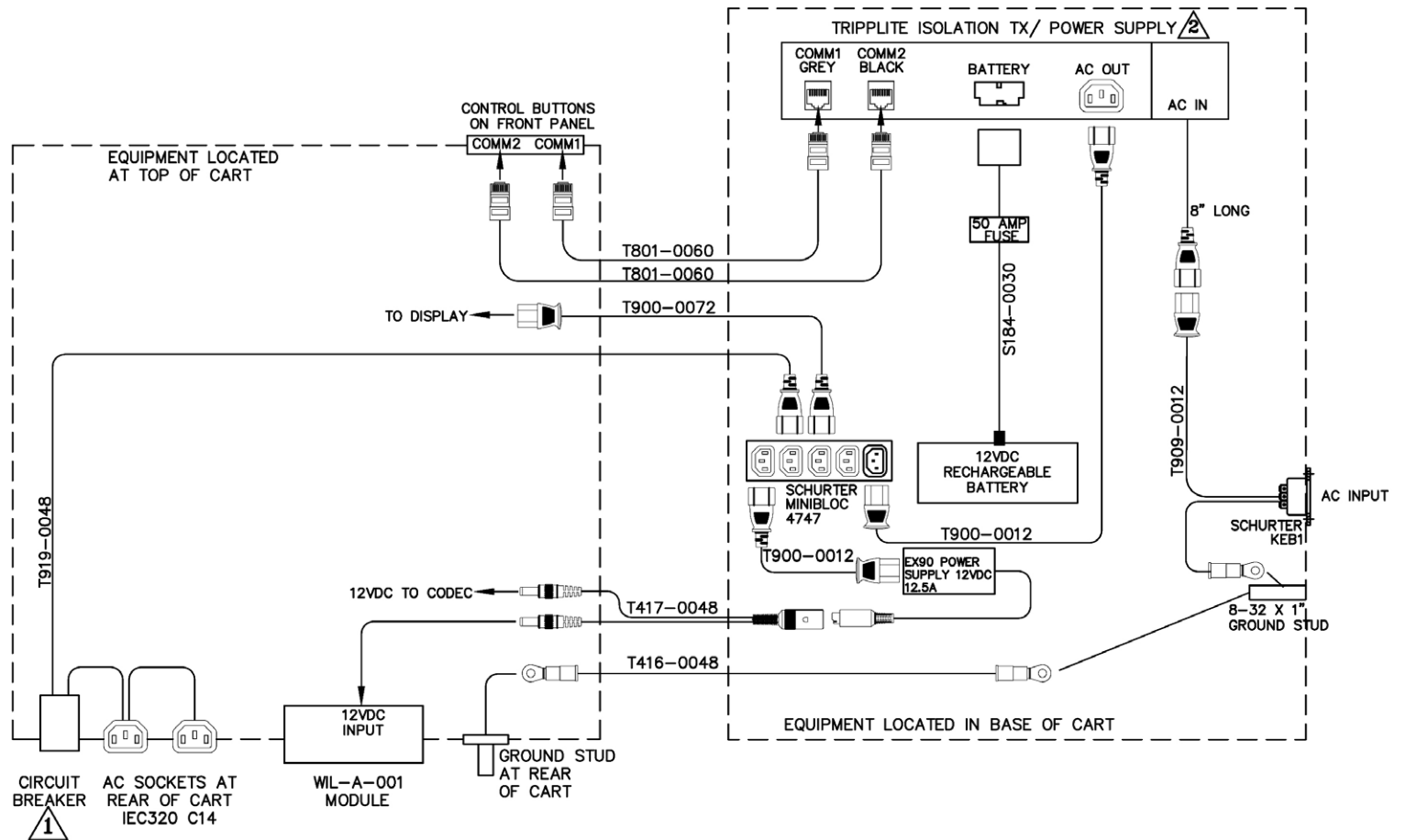

NOTE: The battery in this product is non-user replaceable and should be removed by a service technician only.

FILE NAME : YC2SC05C

Audio Schematics

Power Schematics

Audio Schematics

Video Schematics

Control Schematics

NOTES:

⚠ WHEN A HEADPHONE IS CONNECTED THE SPEAKERS ARE DISCONNECTED

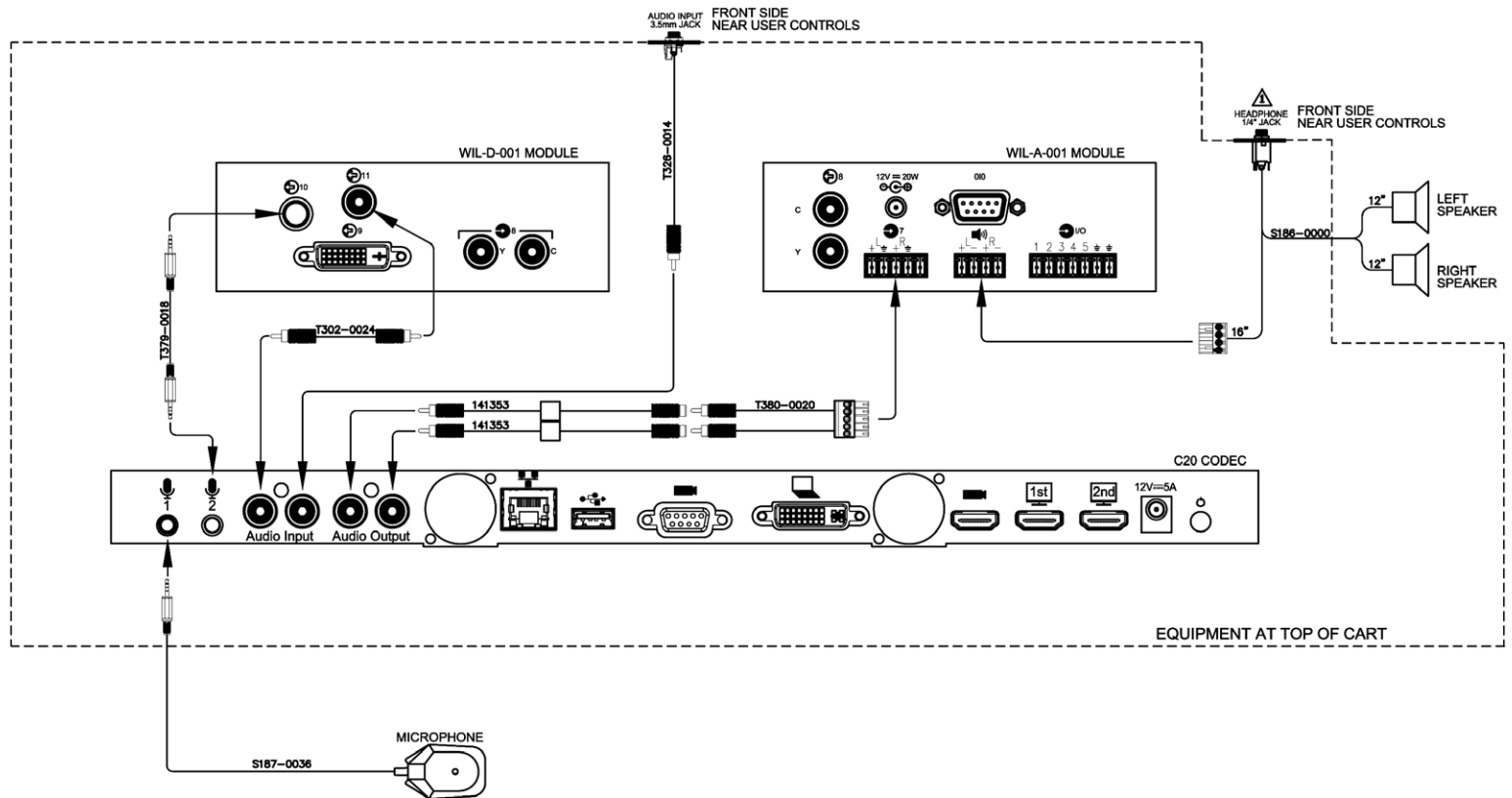

FILE NAME : YC2SC08C

Video Schematics



Power Schematics

Audio Schematics

Video Schematics

Control Schematics

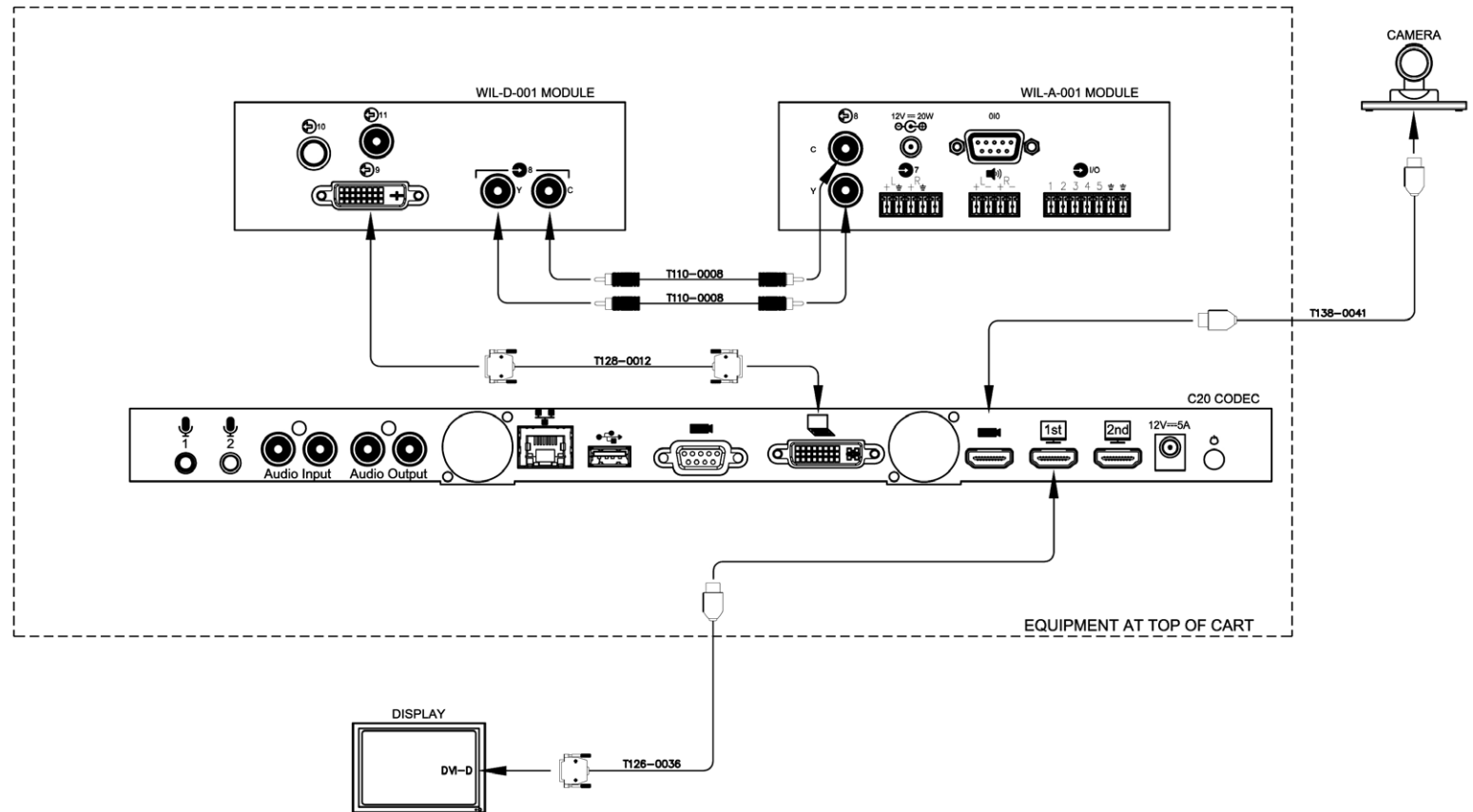

FILE NAME : YC28C01C

Control Schematics



- Power Schematics
- Audio Schematics
- Video Schematics
- Control Schematics**

NOTES:

- ⚠ THE WIRELESS ACCESS POINT IS OPTIONAL
- ⚠ THIS PORT WILL EITHER CONNECT TO THE WIRELESS ACCESS POINT OR TO THE LOCAL LAN

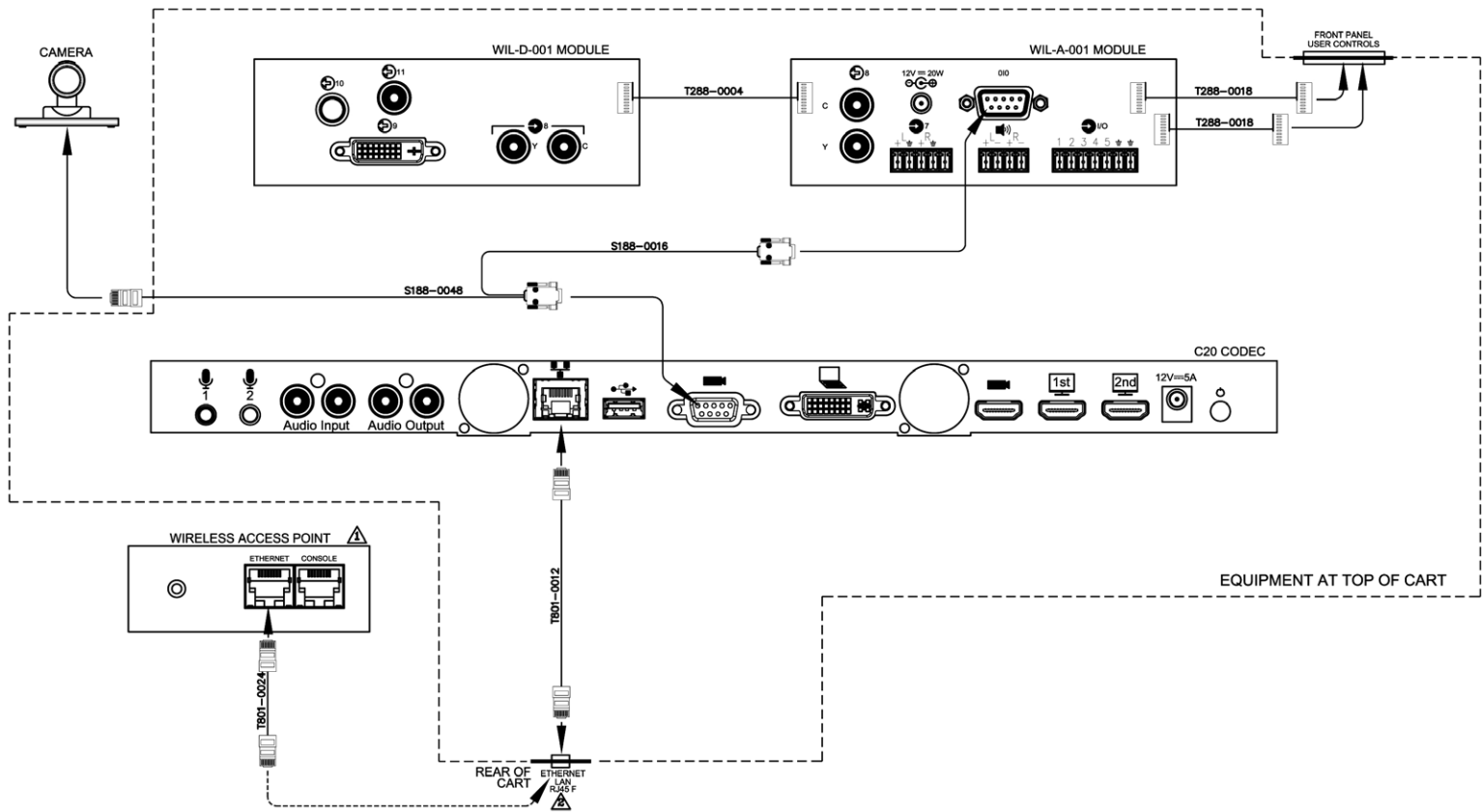

FILE NAME : YC28C02C

Using the System



- Turning the System On
- Making a Call
- System Interface

Turning the System On

When connected to AC outlet, simply turn ON the unit with the power switch at the rear of the unit's BASE and then press and hold the system's POWER BUTTON on the POWER CONTROL AND BATTERY METER PANEL for one second.

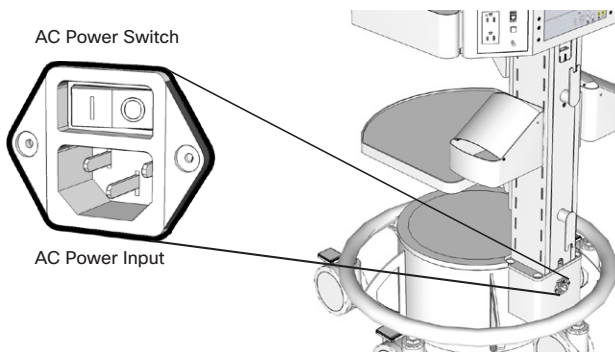

When operating with the battery only, press and hold the system's POWER BUTTON for one second on the POWER CONTROL AND BATTERY METER PANEL.

NOTE: The switch at the unit's base toggles AC power only. The battery will operate when it has a charge and the system is not connected to AC power. The battery will not charge unless the AC switch is on and plugged in to an AC outlet.

POWER BUTTON
This button turns the Power Supply Module's outlets (and any connected equipment) on and off.

To turn the Power Supply Module's outlets ON: Press and hold the "Power" button for one second. The alarm will beep once briefly after one second has passed. Release the button. The "Power" LED will illuminate. The "Power" button will turn the outlets on regardless of whether the Power Supply Module is plugged in or not.

To turn the Power Supply Module's outlets OFF: Press and hold the "Power" button for one second. The alarm will beep once briefly after one second has passed. Release the button. The "Power" LED will turn off.

POWER LED
This green LED indicates whether the Power Supply Module's outlets are ON or OFF.

BATTERY CHARGE LED METER
These LEDs will illuminate in several sequences to indicate the approximate charge level of the Battery Module. See "Operation" section for charts illustrating Battery Charge LED Meter Display depending on different charge levels while discharging and charging.

ALARM MUTE BUTTON
This button silences the Power Supply Module's low battery alarm. To silence the low battery alarm, briefly press and release the Alarm Mute button. The low battery alarm will beep once per second unless it is silenced. Once the charge level falls below 30% (and shutdown is imminent) the alarm will resume again after one minute. Once the charge level falls below 30%, the user should save open files and safely shut down connected equipment immediately. If the cart is unattended and PowerAlert Software is loaded on a computer connected to the Power Supply Module, PowerAlert will automatically save open files prior to automatic shutdown.

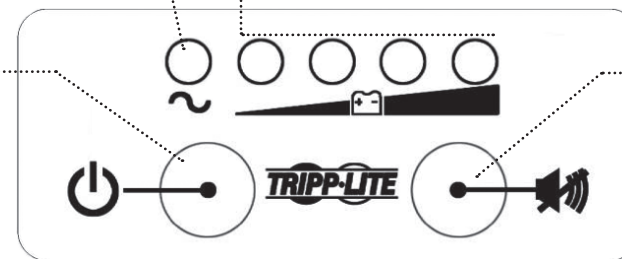

POWER CONTROL AND BATTERY METER PANEL

MOBILE OPERATION (UNPLUGGED / DISCHARGING)
Unplug the Power Supply Module from the AC wall outlet. Ensure that the cord is safely stowed aboard the cart to reduce the risk of damage.

Use connected equipment between charges, depending on battery conditions, environmental conditions and equipment load. As the Battery Module's charge is depleted, the Battery Charge LED Meter will indicate the approximate charge level (see chart).

To turn the Power Supply Module's outlets (and any connected equipment) OFF and stop the battery from discharging, press the "Power" button for one second. The alarm will beep once briefly after one second has passed. Release the button. All LEDs will be OFF.

STATIONARY OPERATION (PLUGGED IN / CHARGING)
Plug the Power Supply Module into a live AC wall outlet.* The Power Supply Module will deliver AC power to connected equipment while simultaneously charging the Battery Module.

Use connected equipment indefinitely as long as the Power Supply is connected to a live AC outlet. If the utility power fails, due to a blackout or severe brownout, the Power Supply will automatically support connected equipment with AC power from the Battery Module (if adequately charged). When power resumes after a blackout, the Power Supply will automatically resume supplying AC power and recharging the Battery Module.

Charge Level Indicators (Discharging)

Approximate Battery Module Charge Level	Battery Charge LED Meter Display				Low Battery Alarm*
	LED 1	LED 2	LED 3	LED 4	
90 - 100%	Green	Green	Green	Green	OFF
60% - 89%	Green	Green	Green	OFF	OFF
31% - 59%	Yellow	Yellow	OFF	OFF	ON
<= 30%	Flashing Red	OFF	OFF	OFF	ON

* The low battery alarm will beep once per second unless it is silenced by pressing the "Alarm Mute" button. Once the charge level falls below 30% (and shutdown is imminent) the alarm will resume again after one minute. The user should save open files and safely shut down connected equipment immediately. If the cart is unattended and PowerAlert Software is loaded on a computer connected to the Power Supply Module, PowerAlert will automatically save open files prior to automatic shutdown.

Charge Level Indicators (Charging)

Approximate Battery Module Charge Level	Battery Charge LED Meter Display			
	LED 1	LED 2	LED 3	LED 4
90 - 100%	Green	Green	Green	Green
60% - 89%	Green	Green	Green	Flashing Green
31% - 59%	Green	Green	OFF	Flashing Green
<= 30%	Green	OFF	OFF	Flashing Green

* Tripp Lite recommends that the Power Supply be plugged into a wall outlet, charging the battery as often as possible. Charging the batteries for brief intervals DOES NOT adversely affect battery performance. However, leaving the batteries fully discharged for long periods of time DOES adversely affect battery performance.

Call Controls



The VX Clinical Assistant makes video calls and presentations using the Cisco Telepresence Codec C20, housed within the system, and its accompanying Control Interface. A Remote Control is included to provide advanced codec functionality.

The system control interface on the VX Clinical Assistant provides simple source control options once you are connected to a video call.

Please refer to the C-Series codec documentation for instructions on making calls and using the remote control.

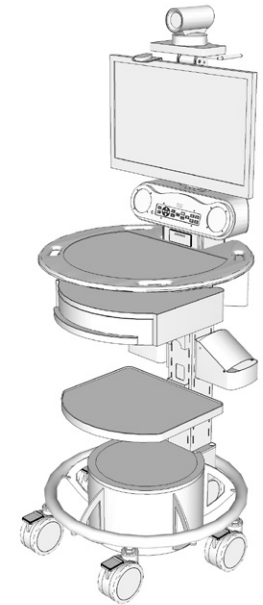
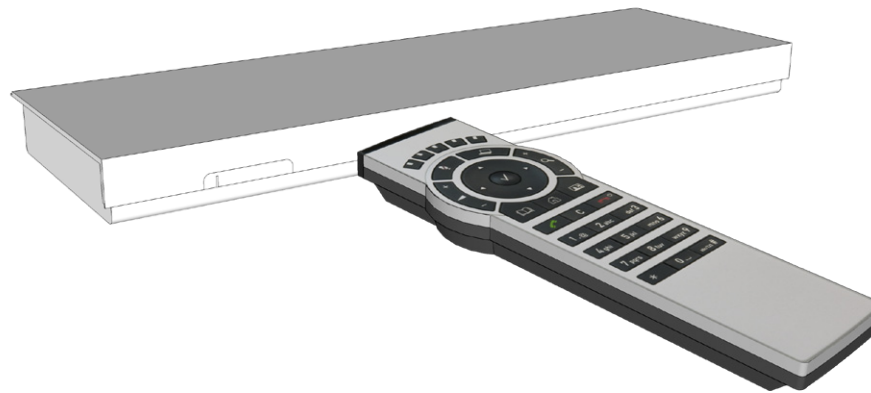

You may access additional documentation online at:

<http://www.Cisco.com/support/>

Select DOCUMENTATION in the menu to search.

Source Control and Rear Interface



The REAR INTERFACE provides video, audio, and computer connectivity. The corresponding SOURCE CONTROLS found at the front of the VX Clinical Assistant are designed to provide simple use and quick access to sources when in a call or for local presentation.

- VOLUME** - Increase or decrease the volume output from the system's speakers or connected headphones.
- CAMERA CONTROL** - Control the system's camera position.
- ZOOM** - Increase or decrease the system's camera zoom.
- LAYOUT** - Toggle through various screen layouts from the Cisco Codec C20. Refer to the codec's documentation to understand the various layouts when in a call and when not in call.
- CAMERA** - Present the system camera.
- COMPUTER** - Present the connected computer.
- VIDEO SOURCES 1-5** - Display the video sources connected to the corresponding video inputs on the REAR INTERFACE.



- SOURCE CONTROLS -

- HDMI IN or S-VIDEO IN** (S-VIDEO ONLY if no HDMI signal present)
- HDMI IN or S-VIDEO IN** (S-VIDEO ONLY if no HDMI signal present)
- DVI-I IN or S-VIDEO IN** (S-VIDEO ONLY if no DVI signal present)
- DVI-I IN and 3.5mm STEREO MINI PLUG**
- 3.5mm QUICKSET MIC IN** (for additional coverage)
- USB 1-3** Used for diagnostics, firmware updates, and configuration.
- COMPOSITE VIDEO IN**
- COMPOSITE VIDEO IN**
- COMPOSITE VIDEO IN** (corresponds to if no DVI signal present)
- ANALOG VIDEO OUT** (outputs signal from S-VIDEO IN 1, 2, 3 and COMPOSITE VIDEO IN 4, 5, 6)

- REAR INTERFACE -

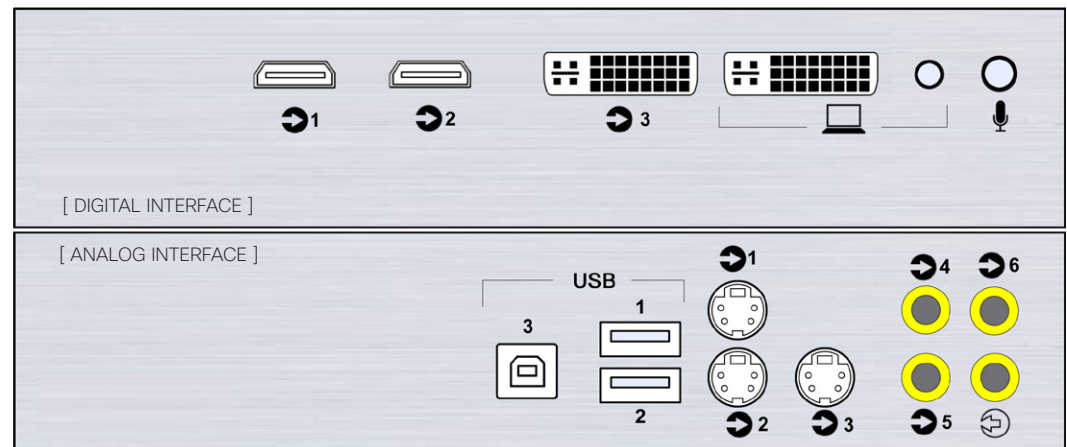

Headphone and Audio Input



Headphone Output

The 1/4" HEADPHONE OUTPUT at the left of the SOURCE CONTROLS panel provides audio through a connected headphone. When connected, the audio will be cut off from the integrated speakers -- audio is only heard through the headphones.

Control the headphone volume using the VOLUME CONTROLS on the Source Controls panel.

Audio Input

The 3.5mm line level AUDIO INPUT is located at the right of the SOURCE CONTROLS panel. The audio from the connected source (stethoscope or other) will be **transmitted and heard locally** through the system's speakers. If using a stethoscope, it is recommended that the HEADPHONE AUDIO OUT be used to listen to the stethoscope's audio.

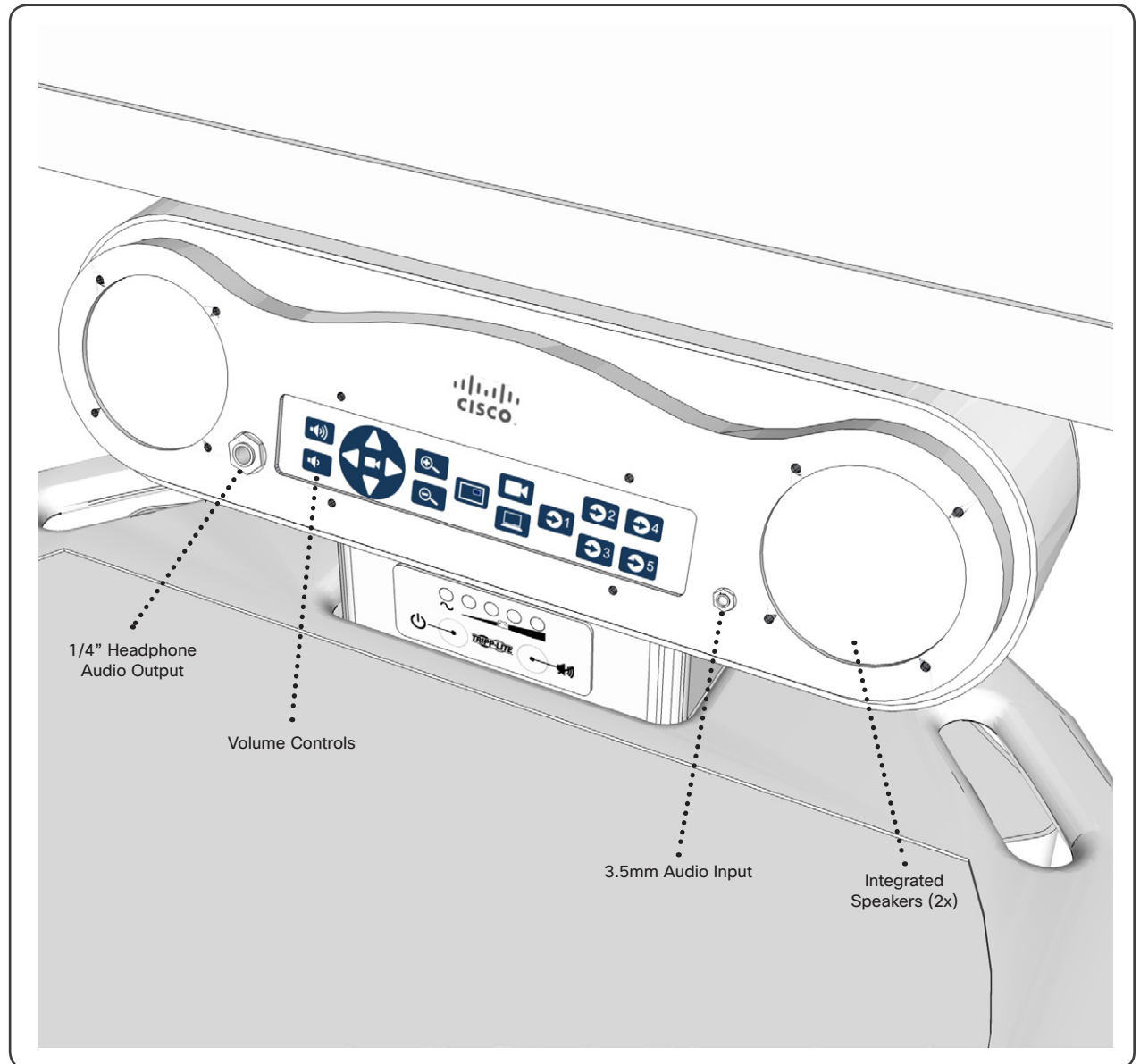

Cleaning the System



The surface materials of the VX Clinical Assistant are durable and easy to maintain.

Please refer to the respective Materials Safety Data Sheets (MSDS) for detailed descriptions for each product from its manufacturer.

DuPont™ Corian® Solid Surface

www.dupont.com

www.corian.com

Wilsonart® Chemsurf®

www.wilsonartlaminat.com

800-433-3222

DuPont™ Corian® Solid Surface (light-colored solid material)

General and everyday cleaning can be done by wiping the surface with a damp cloth or sponge, then dry with soft cloth or paper towels. An ammonia-based, non-abrasive cleaner may be used for stains.

Disinfect the surface with the appropriate sterilant or disinfectant.

Prolonged exposure to concentrated, undiluted disinfectant solutions may degloss or etch solid surface material and require refinishing to restore the surface to its original condition. Using a wet Scotch-Brite® pad and bleaching and/or abrasive cleanser may restore the surface finish.

GENERAL CLEANING:

1. Before cleaning, ensure that the monitor is turned off.
2. Direct the suction nozzle of vacuum cleaner to remove dirt/dust accumulated in crevices. Hand brush may be used to assist in removing settled dirt/dust.
3. Use cloth dampens with ethyl alcohol to wipe

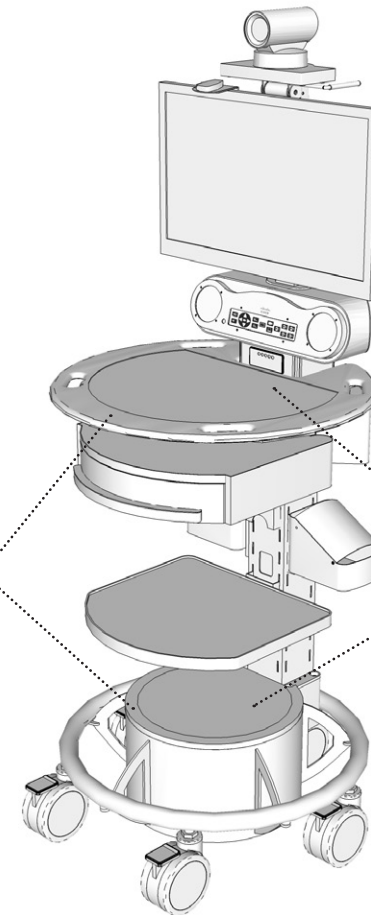

clean the surfaces. Do not use excessive alcohol as the disinfectant is flammable.

4. Use 0.1% hypochlorite solution to wipe clean the surface of CPU or laptop and monitor casings. Wait for 5 minutes and use another piece of cloth dampened with water to clean off residual hypochlorite.
5. The glass surface of video display terminals with cathode ray tubes may be cleaned and

Wilsonart® Atlantis D525-60 (blue inlaid laminate material)

Clean with warm water and mild soaps, such as those used for hands or dishes. Avoid cleansers containing abrasives, acids, or alkalis.

Stubborn stains may be removed with a 1.5 minute exposure to hypochlorite bleach (such as Clorox®) followed by a clean water rinse.

It is recommend that you not allow any of the following reagents to remain in contact with the decorative surface:

1. Hypochlorite bleach, except as described above
2. Hydrogen peroxide solution
3. Mineral acids, hydrochloric acid such as Lime-A-Way™, sulfuric or nitric acid
4. Caustic solutions containing greater than 2% lye, such as Drano®
5. Sodium bisulfate, such as Sani-Flush®
6. Potassium permanganate
7. Berry juices
8. Silver nitrate, in 1% concentration
9. Gentian violet
10. Mild silver protein, such as 20% Argyrol
11. Bluing
12. Fabric dye, such as Tintex® or Rit®
13. Alcohol containing 1% iodine in solution.

disinfected using diluted hypochlorite solution.

6. The video display surface of LCD monitor should be wiped gently using a damp cloth.

POWER

No power to cart

Verify the unit is plugged in and the rear input switch is on. Verify the power has been turned on both at the AC power control at the base of the cart and the battery meter panel beneath the display.

No power to monitor

Verify power to the cart and the monitor are switched ON. Once on, powering on/off the cart will automatically power the monitors.

No power to camera

Verify power to the cart and verify the connection to the camera control port of the camera.

VIDEO

No video on the monitor(s)

Make sure power is going to the monitor(s) and the DVI-D input source is selected on the monitor. Ensure the codec is not in a sleep state by pressing a button on the remote control or front button panel.

PC not recognized by the codec, not shown on the monitor when selecting PC input.

Maximum resolution for the DVI and HDMI

inputs is 1920 x 1080 @ 60 Hz (1920 x 1200 at 50 Hz). Resolutions above that will not be recognized by the codec.

Presenter Option issues/No Content sharing.

The Natural Presenter Package (NPP) option may not be installed. Check the system information screen to verify the NPP is installed. The NPP should be default on the system. If the package is not installed, contact technical services).

Can't see the far end in a call, selfview only.

Verify that the selfview is not selected with the remote control. Pressing the selfview button on the remote control will toggle between far and near end video.

Far side video blocky/discolored/frozen

If disruptions are apparent in the datastream, view the percentages of lost packets in the call status pages. Attempting calls at lower bandwidths may lessen or eliminate the disruptions.

How do I see my selfview.

Pressing the selfview button on the remote control will toggle between far and near end video.

AUDIO

No audio from the system.

Use volume controls to make sure the volume is at a reasonable level (approximately 75%). Make sure the headphone jack is clear. Audio alert tones and ringer settings may be sampled to verify audio from the codec.

Far side cannot hear me

Verify that the microphone is not muted (no on-screen mute icon). Check the audio input levels screen in the codec's advanced configuration for microphone 1.

CONTROL

No control of the camera

Verify power to the camera and no menus are on the screen for remote operation. Remote should be pointed at the camera. Verify remote control operation by pointing the remote directly into the lens of the camera at a distance of 2-3 inches. When viewing the selfview the IR transmitter should be blinking. If not, change remote control batteries.

Not able to switch video inputs/buttons

Verify Dataport 1 baud rate is set to 38400 N,8,1 in the dataport advanced settings.

Remote control not working

Remote should be pointed directly at the camera for operation. Correct remote control operation can be verified by pointing the remote directly into the lens of the camera. The IR transmitter should be blinking. If there no indication of transmission, change remote control batteries.

For additional codec troubleshooting articles please visit:

<http://www.tandberg.com/support/video-conferencing-knowledge-base/faq-topics/troubleshooting-2.jsp>

Frequently Asked Questions



How do I obtain the software version and IP address?

With remote press home button for the home menu to displayed and then press the fifth soft key (top of remote) which will display the system information.

Where can I find additional information, downloads, and manuals?

Additional information can be found at the Cisco website listed below.

<http://www.Cisco.com/support/>

How many devices may I connect to the AC outlets on the rear of the cart?

The system will allow a maximum of 150 Watts from the rear AC outlets.

Can I access the system remotely?

Call control and endpoint configuration is available through the codec's web interface. Enter the username and password for permissions. The default username is "admin" without a password.

Who do I contact for system repairs?

For assistance regarding repairs to the VX Clinical Assistant, contact Cisco Systems:

http://www.cisco.com/en/US/support/tsd_cisco_worldwide_contacts.html

Technical Specifications



UNIT DELIVERED COMPLETE WITH:

Base Cart with C20 codec, PrecisionHD 4x camera, 24" widescreen LCD, Integrated microphone and speakers, rechargeable battery, remote control, and cables.

- 1280x768@60Hz(WXGA)
- 1280x1024@60,75Hz(SXGA)
- 1024x768@60,75Hz(XGA)
- 800x600@60,72,75,85Hz(SVGA)
- 640x480@60Hz(VGA)

DISPLAY

- 24-in. widescreen LCD/LED backlight monitor
- Maximum resolution: 1920x1080
- Color support: 16.7 million colors
- Response time: 5 ms
- Display positions adjustment: Tilt
- Display screen coating: Antiglare
- Features: f-Engine technology, SUPER energy saving technology
- Image contrast ratio: 1000:1 and 5000000:1 (dynamic)
- Image brightness: 250 cd/m²
- Image maximum H-View angle: 170
- Image maximum V-View angle: 160
- Kensington Lock Connection

VIDEO INPUTS

- Three (3) S-video inputs (4-pin mini din connectors)
- Three (3) composite inputs (RCA connectors)
 - PAL/NTSC
- Three (3) High-Definition Multimedia Interface (HDMI) inputs (one designated as main camera input); supported formats:
 - 1920x1080@60Hz(1080p60)
 - 1920x1080@50Hz(1080p50)
 - 1920x1080@30Hz(1080p30)
 - 1280x720@60Hz(720p60)
 - 1280x720@50Hz(720p50)
 - 1440x900@60Hz(WXGA+)
 - 1280x768@60Hz(WXGA)
 - 1280x1024@60,75Hz(SXGA)
 - 1024x768@60,75Hz(XGA)
 - 800x600@60,72,75,85Hz(SVGA)
 - 640x480@60Hz(VGA)
- Two (2) Digital Visual Interface Input (DVI-I) inputs (one designated as PC input); supported formats:

Analog (Video Graphics Array [VGA]):

- 1920x1080@60Hz(1080p60)
- 1280x720@60Hz(720p60)
- 1440x900@60Hz(WXGA+)
- 1280x768@60Hz(WXGA)
- 1280x1024@60,75Hz(SXGA)
- 1024x768@60,75Hz(XGA)
- 800x600@60,72,75,85Hz(SVGA)
- 640x480@60Hz(VGA)

Digital (DVI-D)

- 1920x1080@60Hz(1080p60)
- 1920x1080@50Hz(1080p50)
- 1920x1080@30Hz(1080p30)
- 1280x720@60Hz(720p60)
- 1280x720@50Hz(720p50)
- 1440x900@60Hz(WXGA+)

VIDEO OUTPUTS

- One (1) composite output (RCA connector)
- One (1) HDMI output (main display); supported formats:
 - 1920x1080@60Hz(1080p60)
 - 1280x720@60Hz(720p60)
 - 1280x768@60Hz(WXGA)
 - 1280x1024@60Hz(SXGA)
 - 1024x768@60Hz(XGA)
 - 800x600@60Hz(SVGA)
 - 640x480@60Hz(VGA)

AUDIO INPUTS

- Two microphones, 4 pin MiniJack with mono signal with 1 echo canceller
- Two 3.5-mm audio inputs, line level: 1 back of system for PC audio, 1 front of system for electronic audio systems

AUDIO OUTPUT

- One 1/4 Phono line level: front of system for Head Phones

CAMERA

- Cisco TelePresence PrecisionHD Camera: 1080p
- One-third-inch complementary metal oxide semiconductor (CMOS)
- 4x zoom or 12x zoom
- +15° and -25° tilt, +/- 90° pan
- 43.5° vertical field of view
- 72° horizontal field of view
- Focus distance 0.3m-infinity
- 1920x1080 pixels progressive@30 frames per second (fps) (4x version)
- 1920x1080 pixels progressive@60 fps (12x version)
- Other formats supported (configurable through dip-switch, 12x version only):
 - 1920x1080@60fps (HDMI only)
 - 1920x1080@50fps (HDMI only)
 - 1920x1080@30fps
 - 1920x1080@25fps
 - 1280x720@60fps
 - 1280x720@50fps
 - 1280x720@30fps
 - 1280x720@25fps
- Automatic or manual focus, brightness, and white balance
- Far-end camera control
- Kensington Lock Connection

USER INTERFACE

- TRC 5 I/R remote control for full system control
- "One-touch" tactile control panel for supple-

mental control of volume, camera, and video source

BANDWIDTH

- H.323 and Session Initiation Protocol (SIP) up to 6 Mbps point-to-point
- 720p30 from 768 kbps
- 720p60 from 1152 kbps
- 1080p30 from 1472 kbps

VIDEO STANDARDS

H.261, H.263, H.263+, H.264

VIDEO FEATURES

- Native 16:9 widescreen
- Advanced screen layouts
- Intelligent video management
- Local auto layout

LIVE VIDEO RESOLUTIONS (ENCODE and DECODE)

- 176x144@30 fps (QCIF)
- 352x288@30 fps (CIF)
- 512x288@30 fps (w288p)
- 576x448@30 fps (448p)
- 768x448@30 fps (w448p)
- 704x576@30 fps (4CIF)
- 1024x576@30 fps (w576p)
- 1280x720@30 fps (720p30)
- 1920x1080@30 fps (1080p30) (requires option)
- 512x288@60 fps (w288p60)
- 768x448@60 fps (w448p60)
- 1024x576@60 fps (w576p60)
- 1280x720@60 fps (720p60) (requires option)
- 640x480@30 fps (VGA)
- 800x600@30 fps (SVGA)
- 1024x768@30 fps (XGA)
- 1280x768@30 fps (WXGA)

AUDIO STANDARDS

G.711, G.722, G.722.1, 64 kbps MPEG4 AAC-LD

AUDIO FEATURES

- CD-quality 20-kHz mono
- One acoustic echo canceller
- Automatic Gain Control (AGC)
- Automatic noise reduction
- Active lip synchronization

DUAL STREAM

- H.239 (H.323) dual stream
- Binary Floor Control Protocol (BFCP) (SIP) dual stream
- Support for resolutions up to WXGAp15 (main video maximum 720p30)

PROTOCOLS

H.323, SIP

NETWORK INTERFACES

One LAN or Ethernet (RJ-45) 10/100/1000 Mbps

OTHER INTERFACES

- Three USB inputs for diagnostics and upgrades

IP NETWORK FEATURES

- Domain Name System (DNS) lookup for service configuration
- Differentiated Services (quality of service [QoS])
- IP adaptive bandwidth management (including flow control)
- Auto gatekeeper discovery
- Dynamic playout and lip-sync buffering
- H.245 dual-tone multifrequency (DTMF) tones in H.323
- Date and time support with Network Time Protocol (NTP)
- Packet loss-based downspeeding
- Uniform Resource Identifier (URI) dialing
- TCP/IP
- Dynamic Host Configuration Protocol (DHCP)
- IEEE 802.1x network authentication
- ClearPath

FIREWALL TRAVERSAL

- Cisco TelePresence Video Communication Server Expressway
- H.460.18 and H.460.19 Firewall Traversal

EMBEDDED ENCRYPTION

- H.323 and SIP point-to-point
- Standards-based: H.235v3 and Advanced Encryption Standard (AES)
- Automatic key generation and exchange
- Support in dual stream
- Auto NAT
- SIP ICE

SECURITY FEATURES

- Management through Secure HTTP (HTTPS) and Secure Shell (SSH) Protocol
- IP administration password
- Menu administration password
- Disable IP services
- Network settings protection

SYSTEM MANAGEMENT

- Support for Cisco TelePresence Management Suite
- Total management through embedded Simple Network Management Protocol (SNMP), Telnet, SSH, XML, and
- Simple Object Access Protocol (SOAP)
- Remote software upload: Through web server, Secure Copy Protocol, HTTP, and HTTPS
- Remote control and on-screen menu system
- One RS-232 for local control and diagnostics (Y-cable required)

DIRECTORY SERVICES

- Support for local directories (My Contacts)
- Corporate directory
- Unlimited entries using server directory
- Lightweight Directory Access Protocol (LDAP) and H.350
- Unlimited number for corporate directory (available with Cisco TelePresence Management Suite local directory: 200 numbers)
- Received calls
- Placed calls
- Missed calls with date and time

PHYSICAL DIMENSIONS

- Diameter: 27 in. (68.5 cm)
- Height: 67 in. (170 cm)
- Weight: 170 lb (77.11 kg) (without accessory options)

POWER

- 120 VAC, 60 Hz, 5.1 A or 230 VAC, 50 Hz, 2.7 A
- 90 watts (nominal) up to 240 watts maximum with peripheral equipment
- 40 Ah rechargeable battery
- Rear of cart: Two 120 VAC, 60 Hz or 230 VAC, 50 Hz -- 150 watts maximum medical grade AC receptacles for peripheral equipment
- Medical grade isolation transformer

OPERATING TEMPERATURE AND HUMIDITY

- 50 to 95°F (10 to 35°C) ambient temperature
- 20 to 90% relative humidity (RH)
- Atmospheric pressure: 700 to 1060 hPa

STORAGE AND TRANSPORT TEMPERATURE

- -4 to 140°F (-20 to 60°C) at RH 10 to 90% (noncondensing) at RH 20 to 90%
- Atmospheric pressure: 700 to 1060 hPa

APPROVALS AND COMPLIANCE (PENDING)

- IEC 60601-1-2nd edition
- IEC 60950-1
- EN 60950-1
- UL 60601-1
- UL 60950-1
- CSA C22.2 No. 60601.1
- CSA C22.2 No. 60950-1
- Compliance with FCC 47 CFR Part 15
- FDA Class I Medical Device Data System (MDDS)
- Medical Device Directive EN 60601-1 Class I Equipment
- Patient Applied Parts - Type B equipment.



- Continuous Operation (Mode of Operation)

Electromagnetic Emissions and Immunity Summary



The Teleconferencing Unit is intended for use in the electromagnetic environment specified below. The customer or the user of the Teleconferencing Unit should assure that it is used in such an environment.

Guidance and manufacturer's declaration -- electromagnetic emissions -- for all ME equipment and ME systems (See clause 5.2.2.1 c) of IEC 60601-1-2:2007)		
Emissions test	Compliance	Electromagnetic environment - guidance
RF emissions CISPR 11	Group 1	The Cisco TelePresence Unit uses RF energy only for its internal function. Therefore, its RF emission are very low and are not likely to cause any interference in nearby electronic equipment.
RF emissions CISPR 11	Class A	The Cisco TelePresence Unit is suitable for use in all establishments other than domestic and those directly connected to the public low-voltage power supply network that supplies buildings used for domestic purposes.
Harmonic emissions IEC 61000-3-2	Class A	
Voltage fluctuation/flicker emissions IEC 61000-3-3	Complies	

Recommended separation distances between portable and mobile RF communications equipment and the ME equipment or ME system (See clause 5.2.2.2) of IEC 60601-1-2:2007)			
The Cisco TelePresence Unit is intended for the use in an electromagnetic environment in which radiated RF disturbances are controlled. The customer or the user if the Teleconferencing Unit can help prevent electromagnetic interference by maintaining a minimum distance between portable and mobile RF communications equipment (transmitters) and the Teleconferencing Unit as recommended below, according to the maximum output power of the communications equipment			
Rated maximum output power on transmitter W	Separation distance according to frequency of transmitter m		
	150 KHz to 80 MHz $d = [1.17] \sqrt{P}$	80 MHz to 800 MHz $d = [1.17] \sqrt{P}$	800 MHz to 2.5 GHz $d = [2.33] \sqrt{P}$
0,01	0.117	0.117	0.233
0,1	0.37	0.37	0.74
1	1.17	1.17	2.33
10	3.70	3.70	7.37
100	11.70	11.70	23.3
For transmitters rated at a maximum output power not listed above, the recommended separation distance d in meters (m) can be estimated using the equation applicable to the frequency of the transmitter, where P is the maximum output power rating of the transmitter in watts (W) according to the transmitter manufacturer.			
NOTE 1: At 80 MHz and 800 MHz, the higher frequency range applies. NOTE 2: These guidelines may not apply in all situations. Electromagnetic propagation is affected by absorption and reflection from structures, objects, and people.			

Guidance and manufacturer's declaration -- electromagnetic immunity -- For all ME equipment and ME systems (See clause 5.2.2.1 f) of IEC 60601-1-2:2007)			
Immunity test	IEC 60601 test level	Compliance level	Electromagnetic environment - Guidance
Electrostatic discharge (ESD) IEC 61000-4-2	±6 kV contact ±8 kV air	±6 kV contact ±8 kV air	Floors should be wood, concrete or ceramic tile. If floors are covered with synthetic material, the relative humidity should be at least 30%.
Electrical fast transient/burst EIC 61000-4-4	±2 kV for power supply lines ±1 kV for input/output lines	±2 kV for power supply lines ±1 kV for input/output lines	Mains power quality should be that of a typical commercial or hospital environment.
Surge IEC 61000-4-5	±1 kV differential mode ±2 kV common mode	±1 kV differential mode ±2 kV common mode	Mains power quality should be that of a typical commercial or hospital environment.
Voltage dips, short interruptions and voltage variations on power supply input lines IEC 61000-4-11	<5 % UT (>95 % dip in UT) for 0,5 cycle 40 % UT (60 % dip in UT) for 5 cycles 70 % UT (30 % dip in UT) for 25 cycles <5 % UT (>95 % dip in UT) for 5 sec	<5 % UT (>95 % dip in UT) for 0,5 cycle 40 % UT (60 % dip in UT) for 5 cycles 70 % UT (30 % dip in UT) for 25 cycles <5 % UT (>95 % dip in UT) for 5 sec	Mains power quality should be that of a typical commercial or hospital environment. If the user of the Teleconferencing Unit requires continued operation during power mains interruptions, it is recommended that the Teleconferencing Unit be powered from an uninterruptible power supply or a battery.
Power frequency (50/60 Hz) magnetic field IEC 61000-4-8	3 A/m	3 A/m	Power frequency magnetic fields should be at levels characteristic of a typical location in a typical commercial environment.
NOTE: UT is the a.c. mains voltage prior to application of the test level.			

Guidance and manufacturer's declaration -- electromagnetic immunity -- for all ME equipment and ME systems that are not Life-Supporting (See clause 5.2.2.2) of IEC 60601-1-2:2007)			
Immunity test	IEC 60601 test level	Compliance level	Electromagnetic environment guidance
Conducted RF IEC 61000-4-6	3 Vrms 150 kHz to 80 MHz	3 Vrms	Portable and mobile RF communications equipment should be used no closer to any part of the Cisco TelePresence Device, including cables, than the recommended separation distance calculated from the equation applicable to the frequency of the transmitter. Recommended separation distance: $d = [1.17] \sqrt{P}$ $d = [1.17] \sqrt{P}$ <i>80MHz to 800MHz</i> $d = [2.33] \sqrt{P}$ <i>800MHz to 2.5GHz</i> where P is the maximum output power rating of the transmitter in watts (W) according to the transmitter manufacturer and d is the recommended separation distance in meters (m). Field strengths from fixed RF transmitters, as determined by an electromagnetic site survey ¹ should be less than the compliance level in each frequency range ² . Interference may occur in the vicinity of equipment marked with the following: 
Radiated RF IEC 61000-4-3	3 V/m 80 MHz to 2.5 GHz	3 V/m	
NOTE 1: At 80 MHz and 800 MHz, the higher frequency range applies. NOTE 2: These guidelines may not apply in all situations. Electromagnetic propagation is affected by absorption and reflection from structures, objects, and people.			
(a) Field strengths from fixed transmitters, such as base stations for radio (cellular/cordless) telephones and land mobile radios, amateur radio, AM and FM radio broadcast and TV broadcast cannot be predicted theoretically with accuracy. To assess the electromagnetic environment due to fixed RF transmitters, an electromagnetic site survey should be considered. If the measured field strength in the location in which the Cisco TelePresence Device issued exceeds the applicable RF compliance level above, the Cisco TelePresence Device should be observed to verify normal operation. If abnormal performance is observed, additional measures may be necessary, such as re-orienting or relocating the Cisco TelePresence Device. (b) Over the frequency range 150 kHz to 80 MHz, field strengths should be less than 3 V/m.			

THE SPECIFICATIONS AND INFORMATION REGARDING THE PRODUCTS IN THIS MANUAL ARE SUBJECT TO CHANGE WITHOUT NOTICE. ALL STATEMENTS, INFORMATION, AND RECOMMENDATIONS IN THIS MANUAL ARE BELIEVED TO BE ACCURATE BUT ARE PRESENTED WITHOUT WARRANTY OF ANY KIND, EXPRESS OR IMPLIED. USERS MUST TAKE FULL RESPONSIBILITY FOR THEIR APPLICATION OF ANY PRODUCTS.

THE SOFTWARE LICENSE AND LIMITED WARRANTY FOR THE ACCOMPANYING PRODUCT ARE SET FORTH IN THE INFORMATION PACKET THAT SHIPPED WITH THE PRODUCT AND ARE INCORPORATED HEREIN BY THIS REFERENCE. IF YOU ARE UNABLE TO LOCATE THE SOFTWARE LICENSE OR LIMITED WARRANTY, CONTACT YOUR CISCO REPRESENTATIVE FOR A COPY.

The Cisco implementation of TCP header compression is an adaptation of a program developed by the University of California, Berkeley (UCB) as part of UCB's public domain version of the UNIX operating system. All rights reserved. Copyright © 1981, Regents of the University of California.

NOTWITHSTANDING ANY OTHER WARRANTY HEREIN, ALL DOCUMENT FILES AND SOFTWARE OF THESE SUPPLIERS ARE PROVIDED "AS IS" WITH ALL FAULTS. CISCO AND THE ABOVE-NAMED SUPPLIERS DISCLAIM ALL WARRANTIES, EXPRESSED OR IMPLIED, INCLUDING, WITHOUT LIMITATION, THOSE OF MERCHANTABILITY, FITNESS FOR A PARTICULAR PURPOSE AND NONINFRINGEMENT OR ARISING FROM A COURSE OF DEALING, USAGE, OR TRADE PRACTICE.

IN NO EVENT SHALL CISCO OR ITS SUPPLIERS BE LIABLE FOR ANY INDIRECT, SPECIAL, CONSEQUENTIAL, OR INCIDENTAL DAMAGES, INCLUDING, WITHOUT LIMITATION, LOST PROFITS OR LOSS OR DAMAGE TO DATA ARISING OUT OF THE USE OR INABILITY TO USE THIS MANUAL, EVEN IF CISCO OR ITS SUPPLIERS HAVE BEEN ADVISED OF THE POSSIBILITY OF SUCH DAMAGES.

Cisco and the Cisco Logo are trademarks of Cisco Systems, Inc. and/or its affiliates in the U.S. and other countries. A listing of Cisco's trademarks can be found at www.cisco.com/go/trademarks. Third party trademarks mentioned are the property of their respective owners. The use of the word partner does not imply a partnership relationship between Cisco and any other company. (1005R)

Any Internet Protocol (IP) addresses and phone numbers used in this document are not intended to be actual addresses and phone numbers. Any examples, command display output, network topology diagrams, and other figures included in the document are shown for illustrative purposes only. Any use of actual IP addresses or phone numbers in illustrative content is unintentional and coincidental.



On our web site you will find an overview of the worldwide Cisco contacts.

Go to: <http://www.cisco.com/web/siteassets/contacts>



Cisco Systems, Inc.
170 West Tasman Dr.
San Jose, CA 95134 USA



Emergo Europe
Molenstraat 15
2513 BH
The Hague, Netherlands

+31.70.345.8570 - phone
+31.70.346.7299 - fax
service@emergogroup.com

Australia Sponsor
Cisco Systems Australia Pty Ltd
Level 9-10, 80 Pacific Highway, North Sydney NSW 2060
Free Call: 1800 805 227
E-mail: asiapac-tac@cisco.com

New Zealand Sponsor
Cisco Systems New Zealand Limited
Level 3, 152 Fanshawe Street, Auckland
Telephone: 0800 44 6237
E-mail: asiapac-tac@cisco.com