

10 Gigabit Ethernet DWDM XPonder Card for the Cisco ONS 15454 Multiservice Transport Platform

The Cisco® ONS 15454 Multiservice Transport Platform (MSTP) features a radical new approach to Ethernet over dense wavelength-division multiplexing (DWDM) transport and aggregation: a 4-port 10 Gigabit Ethernet XPonder that includes DWDM transmission functions and Layer 2 switching functions (Figure 1).

Figure 1. Cisco 10 Gigabit Ethernet XPonder Card



Background

Metropolitan (metro) transport networks must support numerous service demands, from low-rate DS-1/T1, DS-3/E3, 10/100BASE-T, and OC-3/STM-1 to higher-rate OC-12/STM-4, Gigabit Ethernet, OC-48/STM-16, OC-192/STM-64, and 10 Gigabit Ethernet services. In the recent past, as the broadband data services have been growing to become a major service and Ethernet is becoming a basic protocol, service providers need more and more integration between Ethernet switching and transport to optimize capital investment and minimize operating costs. Industrial trends indicate that DWDM is being used to transport the huge amount of bandwidth that broadband services are consuming. As a consequence, DWDM needs to evolve from being able to purely manage Layer 1 (where optical wavelengths are dispatched across the network) to offer Layer 1 and Layer 2 capabilities aimed at providing wavelength connection on top of VLAN management; quality-of-service (QoS) services; and multicast, broadcast, and unicast services – all this with a reliability comparable or better than traditional time-division multiplexing (TDM) technology.

Product Overview

The Cisco ONS 15454 10 Gigabit Ethernet XPonder card portfolio includes two options: a 10 Gigabit Ethernet XPonder card and a 10 Gigabit Ethernet enhanced XPonder card. The portfolio provides a complete solution with the base XPonder optimized for Ethernet access applications, while the enhanced XPonder card provides additional capabilities for Ethernet aggregation rings.

The Cisco ONS 15454 10 Gigabit Ethernet XPonder is a single-slot Cisco ONS 15454 board providing four 10-Gbps Small Form-Factor Pluggable (XFP)-based 10 Gigabit Ethernet ports, two of which provide G.709 digital-wrapper and Enhanced Forward Error Correction (E-FEC) capabilities. These two ports can be equipped also with DWDM XFPs to allow direct interconnection off the XPonder with the DWDM MSTP system. Two client ports can be equipped with various XFPs: 10BASE-LR (ER or ZR in planning stage). The board can be configured in two different operating modes:

- Layer 2 switch: In this operating mode the XPonder behaves as a Layer 2 switch, including the “GR³” protection mechanism.
- Multiple 10 Gigabit Ethernet transponders: In this operating mode the XPonder provides a 1-to-1 mapping between two 10 Gigabit Ethernet ports, enabling equivalent functions of two standard 10 Gigabit Ethernet DWDM transponders. Each of the 10 Gigabit Ethernet ports providing G.709 digital-wrapper and E-FEC are equipped with DWDM XFP to directly interface the cards with the DWDM layer.

DWDM XFPs used as a line interface provide one 10-Gbps, long-reach, ITU-compliant, 100-GHz-spaced optical interface using LC connectors supporting an OUT-2 G.709 digital wrapper and 10 Gigabit Ethernet LAN physical layer (PHY), or 10 Gigabit Ethernet WAN PHY interfaces. There are 40 different card types of DWDM XFP (one per wavelength) enabling support for 40-channel DWDM networks. When operated within the outlined specifications, each card transports the 10 Gigabit Ethernet signal with a maximum bite error rate (BER) of 10E-15.

The XPonder cards are deployable in the 12 multiservice interface card slots of the Cisco ONS 15454 platform, in systems with or without cross-connect cards. The addition of a cross-connect card enables the platform to support hybrid applications, containing transparent 10-Gbps services as well as aggregation of other services supported by the Cisco ONS 15454 platform. The only required common card is the appropriate timing, communications, and control card.

The XPonder card provides many carrier-class features and advanced capabilities necessary to deliver 10 Gigabit Ethernet Metro Ethernet services, including the protocol transparency, flexible protection mechanisms, broadcast and multicast topology flow-through timing, management, and performance monitoring capabilities outlined in the following sections.

Enhanced FEC Capability

The critical feature of the 10 Gigabit Ethernet XPonder is the availability to configure the FEC in three modes (the output bit rate depends on this choice):

- 10.3125 Gbps for 10 Gigabit Ethernet LAN PHY
- 11.095 Gbps for 10 Gigabit Ethernet LAN PHY (over-clocking mode)

Error coding performance can be provisioned:

- NO FEC: No forward error correction
- FEC: Standard G.975 Reed-Salomon algorithm

- E-FEC: Standard G.975.1 two orthogonally concatenated BCH super FEC codes; this FEC scheme contains three parameterizations of the same scheme of two orthogonally interleaved block codes (BCH); the constructed code is decoded iteratively to achieve the expected performance

Protocol Transparency

The XPonder card provides transparent wavelength services on the Cisco ONS 15454 platform. Digital wrapper technology (G.709) adds a management wrapper to the service, allowing the XPonder card to transparently forward the payload while enabling derivation of performance metrics to ensure circuit service quality.

The cards are transparent to the embedded payload and do not access the Cisco ONS 15454 platform cross-connect.

Layer 2 Functions

The XPonder cards can be configured as Ethernet Layer 2 switches:

A tagged VLAN mechanism makes it possible to build an Ethernet ring over a DWDM wavelength. The two trunk ports equipped with DWDM XFPs are used as Layer 1 substratum Network-to-Network Interface (NNI) ports for an Ethernet distribution ring built by various clients shared on the different XPonders belonging to that wavelength (Figure 2).

Figure 2. XPonder Layer 2 Physical Scheme

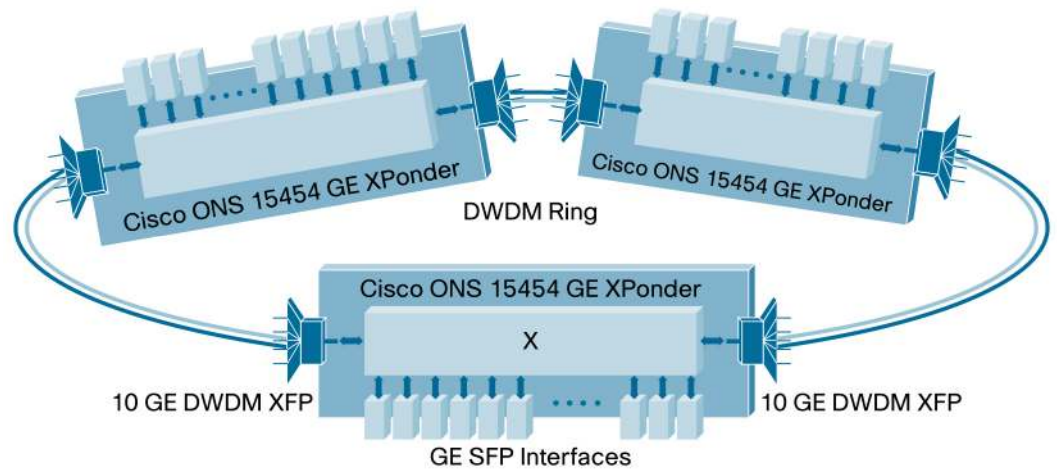
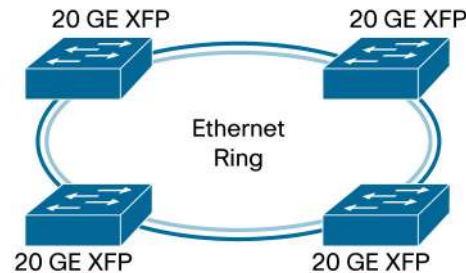

Figure 3. XPonder Layer 2 Logical Scheme



Layer 2 switches support:

- XPonder with MAC address table with up to 16,000 entries
- Enhanced XPonder with MAC address table with up to 32,000 entries*
- Standard 802.1D virtual bridged LANs and VLAN tagging according to the IEEE 802.1Q (up to 4096 VLAN IDs on all ports)
- Standard 801.1ad S-TAG (or outer tag, or QinQ)
- Per-VLAN MAC address enable-disable*

All Layer 2 packet forwarding and multicast replication is performed at wire speed.

The XPonder card provides QoS features such as ingress policing:

- Ingress port-based rate limiting*
- Per-SVLAN-based ingress rate limiting*
- Flow control available (pause frames)
- Policing-based bandwidth metering per port:
 - Single rate: Three-color marker (RFC 2697)
 - Bandwidth profile based on committed information rate (CIR), committed burst size (CBS), and excess burst size (EBS) parameters
 - Only color-blind implementation

Additional QoS functions on Enhanced XPonder include:

- Add of double tag and Add+Translation
- Add SVLAN +Translate CVLAN*
- Per-CVLAN to SVLAN ingress CoS

QoS: Egress Policing

- CoS-based
- One strict-priority and seven Weighted Round Robin (WRR) queues (weight can go from 0 to 15); tail drop to control congestion; when zero is configured the queue is managed as strict-priority queue
- Bandwidth limitation per queue (bandwidth can also be configured per port)
- Up to eight queues configurable for each port

Multicast and Video Broadcast

The Cisco ONS 15454 10 Gigabit Ethernet XPonder supports both push and pull models for video broadcast or multicast applications. The SVLAN-based drop-and-continue approach is used for the push model, where all multicast/video broadcast traffic is dropped at each site. With IGMPv2* capability, the XPonder provides a pull model where a multicast stream or a video channel is pulled on to the network via a join from the end customer. Multicast VLAN registration (MVR)* further enhances network flexibility for video applications where a multicast VLAN is reserved for the network independent of the VLAN on which the service is delivered on each port. The translation from multicast VLAN to customer VLAN happens at the client port.

* Requires system software release 9.0 or later

Flexible Protection Mechanisms

The XPonder card provides flexible protection capabilities for both client and DWDM line interfaces, enabling support for numerous network configurations required to deliver the various service-level agreements (SLAs) required by the customer application.

For a multiple-transponder configuration, the XPonder card supports:

- Unprotected client and line: No client terminal interface, XPonder card, or DWDM line protection; the client signal is transported over a single unprotected XPonder card; this configuration is suitable for transporting client payloads over a DWDM network that is being protected through a Layer 2 or Layer 3 protocol
- Y-cable client interface: Provides XPonder equipment protection without client terminal equipment interface protection; a single client interface is split to two XPonder cards using a Y-protection device
- For a Layer 2 configuration, the XPonder provides redundancy with no single point of failure in a ring configuration:
 - For ring protection, the XPonder provides revolutionary new GR³ Ethernet protection through the G.709 Rapid Resilient Ring Ethernet Protection mechanism, integrating G.709 messaging with an Ethernet VLAN mechanism when configured as Layer 2 switches, to provide reliability comparable to older TDM systems. A recovery time of 50ms (including detection time) can be achieved. The protection mechanism uses a mix of Layer 1 and Layer 2 functions, with fault detection and failure propagation performed through the G.709 bytes (failure propagation is performed at the hardware level) while traffic is flooded, for each protected VLAN on all 10 Gigabit Ethernet WDM rings. One node is identified (through user configuration) as the master node (or port). This node is responsible for opening and closing the Layer 2 VLAN loop in case of failure.
 - The XPonder provides client and card redundancy with SONET/SDH-like 1+1 card protection in either the same or a different shelf (within the same multishelf management domain)* with the following protection models:
 - Active port is enabled while the standby port stays disabled
 - Both active and standby ports are enabled; only the active port forwards while the standby port drops all ingress-egress traffic
 - GR3 protection mechanism is required
 - The Layer 2 XPonder also supports “Y-cable bidirectional-like” switching where two cards in 1+1 protection are connected through a Y-cable to a single client*.

* Requires system software release 9.0 or later

Management

The Cisco ONS 15454 provides comprehensive management capabilities to support the operations, administration, monitoring, and provisioning (OAM&P) capabilities through the integrated Cisco Transport Controller Craft Interface with support from the Cisco Transport Manager element management system (EMS). The XPonder card incorporates provisionable digital-wrapper (G.709) functions, providing per-wavelength performance management capabilities, especially for services being transported transparently across the network. Without the digital-wrapper functions, a carrier transporting a service transparently would be unable to identify network impairments that may degrade the transported signal and exceed SLA requirements. The generic communications channel (GCC) of the digital wrapper enables a separate communications channel on a per-wavelength basis. This GCC enables the Cisco ONS 15454 to extend its advanced network auto-discovery capabilities to DWDM-based services. The integrated Cisco ONS 15454 Transport Controller Craft Manager and the Cisco Transport Manager EMS give users OAM&P access for the system.

End-to-End Circuit EVC Provisioning*

The Cisco ONS 15454 10 Gigabit Ethernet XPonder card provides service and network provisioning with Cisco Transport Controller. The XPonder ring and SVLAN-based Ethernet virtual circuits (EVCs) can be provisioned using Cisco Transport Controller. Both point-to-point and multipoint EVC provisioning is supported.

QoS Provisioning*

The XPonder card provides QoS provisioning through Cisco Transport Controller. Standard system-level QoS profiles can be defined and independently applied on a per-EVC basis.

The XPonder provides remarkable management capabilities for service and QoS provisioning for Carrier Ethernet services.

VLAN Database

The XPonder offers the capability to provision a VLAN database. The Cisco ONS 15454 Transport Controller can perform the action to retrieve all the VLANs available in the network. VLAN retrieval allows users to “view” the WDM ring based on the XPonder card and the EVC/VLAN circuit. Retrieval can be performed on a per-VLAN basis, and it requires the creation of OCH-Trail between the XPonder cards. VLAN retrieval results can be:

- Green: Selected VLAN is configured on both ends of the link
- Orange: Selected VLAN is configured only on one end of the link
- Gray: Selected VLAN is not configured on any end of the link

VLAN Profiling*

All SVLAN associated parameters can be provisioned using predefined profiles.

* Requires system software release 9.0 or later

Performance Monitoring

The performance monitoring capabilities of the XPonder card provide support for Ethernet signal transport. Standard performance parameters for transmit and receive signals are based on RFCs 3635, 2358, 2233, and 1757. Each digital-wrapper channel is monitored per ITU-T digital-wrapper requirements (G.709). Optical parameters on the XFP interfaces are supported, including laser bias, transmit optical power, and receiver optical power. Calculation and accumulation of the performance monitoring data is in 15-minute and 24-hour intervals.

The XPonder card incorporates faceplate-mounted LEDs to provide a quick visual check of the operational status of the card. An orange circle is printed on the faceplate, indicating the shelf slots in which the card can be installed.

Link Integrity*

The XPonder supports link integrity using Y.1731 Ethernet OAM-AIS message per SVLAN. Squelching can be enabled or disabled on a per-port basis.

Cisco IOS Software-Like CLI*

The XPonder supports a Cisco IOS Software-like CLI for management purposes. This allows customers with Cisco IOS Software-based networks to manage the XPonder in a familiar fashion.

Application Description

The XPonder card adds several new applications to an already flexible Cisco ONS 15454 platform. Cards have been developed to meet many different network applications, from pure DWDM point-to-point to VPN services in a Metro Ethernet environment. The availability of pluggable XFP optics for DWDM increases dramatically the density of 10 Gigabit Ethernet, reducing the port cost at the same time.

The Layer 2 switching configuration addresses applications requiring huge bandwidth and high flexibility:

- Video distribution: Video-hub topology fits perfectly in the XPonder architecture. Two different approaches are supported :
 - XPonder-only DWDM ring, where the only Ethernet switching units feeding the DWDM ring are the XPonders: Many Gigabit Ethernet XPonders feed the video-switching-office (VSO) location while the 10 Gigabit Ethernet XPonder feeds the video-headend-office (VHO) location. This topology provides a huge advantage to the capability for supporting GR³ protection.

* Requires system software release 9.0 or later

Figure 4. Video Distribution Using Ethernet XPonders

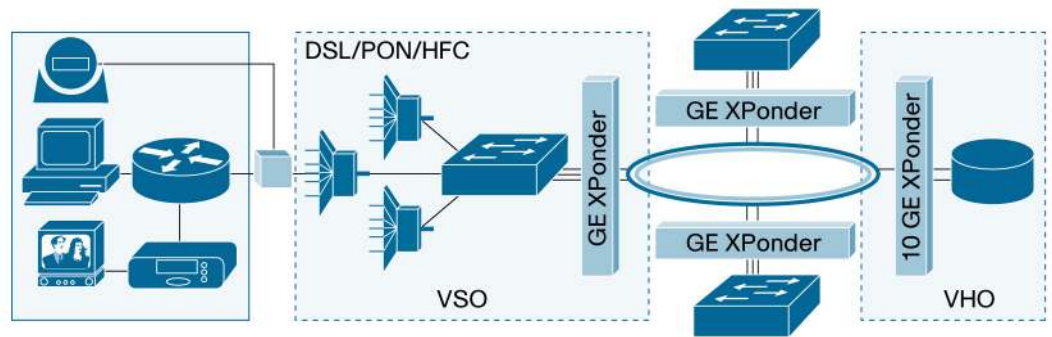

- IP over DWDM (IPoDWDM) architecture, where a Cisco CRS-1 Carrier Routing System or Cisco Catalyst® 7600 are directly facing a DWDM network through WDM PHY interfaces: The primary advantage is the full integration of optical and IP layers, with a common control plane providing provisioning, performance monitoring, and alarm correlation functions in addition to capital expenditures (CapEx) savings by avoiding the use of DWDM transponders.

Figure 5. IP over DWDM (IPoDWDM) Architecture

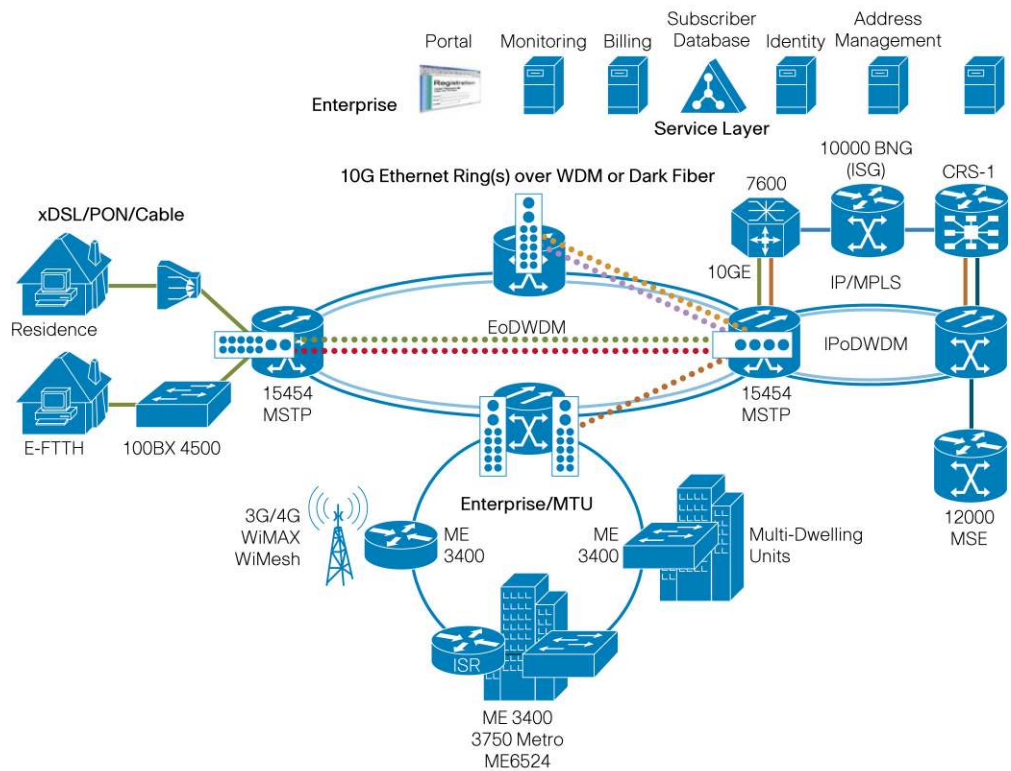

- Cost-optimized Ethernet distribution ring for managed services: Flexibility to aggregate Ethernet on a virtual Ethernet ring in place of many point-to-point transponder-based connections dramatically decreases network CapEx investment.
- Metro Ethernet application: Access-independent architecture with MEF9 and MEF14 certification for environment as Ethernet virtual private line (EVPL) and emulated LAN

(ELAN), demonstrates full support for Ethernet carrier applications and business services as well as triple play with real video, voice, and data services.

- Metro 10 Gigabit Ethernet connectivity: With the addition of 10 Gigabit Ethernet on data terminals, the need for service providers to add a 10 Gigabit Ethernet transport service becomes critical to provide a complete metro service portfolio to their customer bases. The 10 Gigabit Ethernet XPonder card enables service providers to cost-effectively integrate 10 Gigabit Ethernet into their metro service mix over a multiservice network, reducing the need to deploy an overlay metro DWDM platform, and reducing the cost to deploy the service.

The Cisco Advantage

The Cisco ONS 15454 10 Gigabit Ethernet XPonder Card complements and extends the service capabilities of the Cisco ONS 15454 MSTP. The card enables carriers to take advantage of their existing fiber plant and installed base of Cisco ONS 15454 systems, while providing a completely new way to transport and manage Ethernet over the same Cisco ONS 15454 platform.

The Cisco ONS 15454 optical transport solution offers significant advantages over traditional network elements, offering 10-Gbps interfaces, including:

- Unprecedented service densities: The Cisco ONS 15454 platform supports up to twenty-four 10 Gigabit Ethernet interfaces per shelf. When installed in a typical central-office bay frame, a bay can support up to ninety-six 10 Gigabit Ethernet interfaces. These industry-leading densities are attainable because of the single-slot footprint of the 10 Gigabit Ethernet XPonder interface card.
- Common line cards and chassis: Optical line cards are not restoration type-dependent, reducing sparing costs and technician confusion. Additionally, as networks and customer interface demands evolve, users can easily redeploy optical circuit packs as necessary.
- Single software load: One software load supports all restoration types listed previously, eliminating unnecessary guesswork when ordering. All protection configurations are covered under a single right-to-use software license. After the software is purchased, all features and full functions are available to the user.
- Common chassis: A common chassis supporting all optical interface speeds allows the technician to spend time deploying bandwidth and services instead of learning about multiple equipment platforms. Many equipment vendors offer optical line speed-specific platforms (for example, OC-3/STM-1 or OC-12/STM-4) and categorize platforms by restoration mechanisms (for example, Unidirectional Path Switched Ring/Subnetwork Connection Protection, 2 Fiber-Bidirectional Line Switched Ring /Multiplex Section-Switched Protection Ring, and 4 Fiber- Bidirectional Line Switched Ring), not only causing ordering confusion, but bringing into question whether the inventoried equipment will accommodate the functions required to support the desired application. The line-rate and restoration flexibility of the Cisco ONS 15454 platform makes ordering and deploying simple, fast, and easy.
- Multiservice interface selection: DS-1/E1 through OC-192/STM-64, Ethernet, Fast Ethernet, Gigabit Ethernet, and 10 Gigabit Ethernet interfaces are all supported, eliminating the “missing interface” found with many vendors’ bit rate-specific product offerings.

The Cisco ONS 15454, the industry’s leading metro optical transport platform, delivers supercharged SONET/SDH transport, integrated optical networking, unprecedented multiservice interfaces, and competitive economic benefits.

Cisco ONS 15454 10 Gigabit Ethernet XPonder Card Features and Specifications

Compact Design

- Single-width card slot design for high-density, 10 Gigabit Ethernet solutions
- Up to 12 XPonder cards per shelf assembly (240 Gbps), and 96 cards per bay (960 Gbps)

Flexible Restoration Options

- Layer 2 GR³ Ethernet protection: G.709 Rapid Resilient Ring Ethernet protection mechanism
- Client Y-protection
- Unprotected (0 + 1)
- Protected (1+1)*

Table 1 gives regulatory compliance information, Tables 2 through 6 give system requirements and specifications, and Table 7 gives ordering information for the Cisco ONS 15454 10 Gigabit Ethernet XPonder card.

Table 1. Regulatory Compliance¹

ANSI (SONET) System	ETSI (SDH) System
Supported Countries	
<ul style="list-style-type: none"> • Canada • United States 	<ul style="list-style-type: none"> • Europe • Latin America • Japan • Asia Pacific • Middle-East and Africa
EMC (Class A)	
<ul style="list-style-type: none"> • ICES-003 Issue 3 (1997) • GR-1089-CORE, Issue 3 • FCC 47CFR15 subpart B (2004) 	<ul style="list-style-type: none"> • EN 300 386 v1.3.3 (2005) • CISPR22 (2005), CISPR24 (+ Am 1, Am.2 2002) • EN55022 and EN55024
Safety	
<ul style="list-style-type: none"> • UL/CSA 60950-1 First Edition (2003) • GR-1089-CORE, Issue 3 	<ul style="list-style-type: none"> • UL/CSA 60950 -1 First Edition (2003) • IEC 60950-1 (2001-01) First Edition/EN60950-1 (2001), First Edition
Laser	
<ul style="list-style-type: none"> • UL/CSA 60950-1 First Edition (2003) • IEC 60950-1 (2001-01) First Edition/EN60950-1 (2001), First Edition • IEC 60825-2 (2004-06) Third Edition • IEC 60825-1 +Am.1+ Am.2 (2001) • CDRH (Accession letter and report) 	
Environmental	
<ul style="list-style-type: none"> • GR-63-CORE, Issue 2 and Issue 3 	<ul style="list-style-type: none"> • ETS 300-019-2-1 V2.1.2 (Storage, Class 1.1) • ETS 300-019-2-2 V2.1.2 (Transportation, Class 2.3) • ETS 300-019-2-3 V2.1.2 (Operational, Class 3.1E)
Optical	
<ul style="list-style-type: none"> • G.709 • G.975 	

* Requires system software release 9.0 or later

ANSI (SONET) System	ETSI (SDH) System
Miscellaneous	
<ul style="list-style-type: none"> AT&T Network Equipment Development Standards (NEDS) Generic Requirements, AT&T 802-900-260 SBC TP76200MP Verizon SIT.NEBS.NPI.2002.010 Worldcom ESD requirement 	

1. All compliance documentation may not be completed at the time of product release. Please check with your Cisco sales representative for countries outside of Canada, the United States, and the European Union.

Table 2. System Requirements

Component	Cisco ONS 15454 ANSI	Cisco ONS 15454 ETSI
Processor	TCC2P and TCC2	TCC2P and TCC2
Cross-connect	All (not required)	All (not required)
Shelf assembly	15454-SA-HD or 15454-SA-HD-DDR shelf assembly with CC-FTA version fan-tray assembly	15454-SA-ETSI shelf assembly with SDH CC-FTA version fan-tray assembly
System software	Release 8.0 or later	Release 8.0 or later
Slot compatibility	1 to 6 and 12 to 17	1 to 6 and 12 to 17

Table 3. Client-Side Specifications

Specification		
Client Interface	10GE BASE-LR XFP	10GE BASE-ER XFP (available with Release 8.5 onward)
Specification <ul style="list-style-type: none"> IEEE 802.3 	10GE BASE-LR	10GE BASE-ER
Automatic laser shutdown and restart	ITU-T G.664 (06/99)	ITU-T G.664 (06/99)
System reach (SR _{OLB})	4 dB	11 dB
Unamplified targeted fiber distance, SMF28 ¹ (FD ^{SMF28}) <ul style="list-style-type: none"> 10 Gigabit Ethernet 	10 km	40 km
Nominal wavelength (λ_{Tnom})	1310 nm	1550 nm
Spectral range (λ_{Tmin} to λ_{Tmax}) <ul style="list-style-type: none"> 10 Gigabit Ethernet 	1260 to 1355 nm	1530 to 1565 nm
Type	Distributed feedback, direct modulation (DFB/DM) ²	Electro absorption (EML)
Output power (P _{Tmin} to P _{Tmax})	-6 to -1 dBm	-1 to +2 dBm
Minimum required optical return loss <ul style="list-style-type: none"> 10 Gigabit Ethernet 	12 dB	12 dB
Minimum extinction ratio (reminx)	6 dB	8.2 dB
Laser safety class	1	1
Type	PIN	PIN
Sensitivity @ BER (PR _{min} to PR _{max}) <ul style="list-style-type: none"> 10 Gigabit Ethernet 	-14.4 to +0.5 dBm	-14 to 2 dBm
Chromatic dispersion tolerance (D _{SRmax})	6.6 ps/nm (SONET/SDH)	800 ps/nm (SONET/SDH)
Minimum BER (BER _{min})	10E-12	10E-12
Maximum receiver reflectance	-14 dB	-14 dB
Input wavelength bandwidth (λ_{c_rx})	1290 to 1335 nm ³	1530 to 1565 nm ⁴
Connector type (Tx/Rx)	LC-LC	LC-LC

1. Fiber distance of $\langle FD_{SMF28} \rangle$ km in SMF28 of equivalent $\langle SR_{OLB} \rangle$ dB optical link budget. Assumes $D_{1550} = 17$ ps/nm/km, $D_{1310} = 3.3$ ps/nm/km; Fiber + Splice + Connector loss at 1550 nm = 0.275 dB/km and 1310 nm = 0.55 dB/km, including $\langle P_o \rangle$ dB dispersion penalty at $\langle D_{LRlong-reachmax} \rangle$ ps.

2. DFB/DM is typical, but other technologies may be substituted if specifications are met.

3. Acceptable input wavelength range is 1290 to 1605 nm, but receiver sensitivity is guaranteed only for the indicated range

Table 4. xWDM Optical Specifications

Specification	DWDM XFP (ONS-XC-10G-xx.x=)
Automatic Laser Shutdown and Restart	Compliant with ITU-T G.664 (06/99)
Transmitter Wavelength Range	Single wavelength on 100GHz grid (see Table 5)
Transmitter Output Power	-1 dBm (Min) / 3 dBm (Max)
Receiver Wavelength Range	1260 nm to 1607 nm
Input Power Sensitivity (Power Limited)	-7 dBm to -24 dBm (BER $\leq 7 \times 10^{-4}$) (E-FEC), OSNR ≥ 23 dB (0.5nm RBW), CD Tolerance -500ps/nm to 1300ps/nm)
Input Power Sensitivity (OSNR Limited)	-7 dBm to -18 dBm (BER $\leq 7 \times 10^{-4}$) (E-FEC), OSNR ≥ 9 dB (0.5nm RBW), CD Tolerance -500ps/nm to 1100ps/nm)

Table 5. Supported Wavelengths on DWDM Pluggable Units – C Band

xx.x	λ (nm)	ONS-XC-10G-xx.x=
28.7	1528.77	
30.3	1530.33	X
31.1	1531.12	X
31.9	1531.90	X
32.6	1532.68	X
33.4	1533.46	X
34.2	1534.25	X
35.0	1535.04	X
35.8	1535.82	X
36.6	1536.61	X
37.4	1537.40	X
38.1	1538.19	X
38.9	1538.98	X
39.7	1539.77	X
40.5	1540.56	X
41.3	1541.34	X
42.1	1542.14	X
42.9	1542.94	X
43.7	1543.73	X
44.5	1544.53	X
45.3	1545.32	X
46.1	1546.12	X
46.9	1546.92	X
47.7	1547.72	X
48.5	1548.51	X
49.3	1549.31	X
50.1	1550.12	X
50.9	1550.92	X
51.7	1551.72	X
52.5	1552.52	X
53.3	1553.32	X
54.1	1554.13	X
54.9	1554.94	X

xx.x	λ (nm)	ONS-XC-10G-xx.x=
55.7	1555.75	X
56.5	1556.55	X
57.3	1557.36	X
58.1	1558.17	X
58.9	1558.98	X
59.7	1559.79	X
60.6	1560.61	X
61.4	1561.41	X

Table 6. Card Specifications

Specification	
Management	
Card LEDs <ul style="list-style-type: none"> • Failure (FAIL) • Active/standby (ACT/STBY) • Signal fail (SF) Client port LEDs <ul style="list-style-type: none"> • Active input signal DWDM port LEDs <ul style="list-style-type: none"> • Active input signal • Output wavelength 	Red Green/yellow Yellow Green Green Green
Power	
Card power draw with pluggables <ul style="list-style-type: none"> • Typical • Maximum 	76W 79W
Operating Environment	
Temperature	-5 to 55°C (23 to 131°F)
Humidity	5 to 95 percent noncondensing
Storage Environment	
Temperature	-5 to 55°C (23 to 131°F)
Humidity	5 to 95 percent noncondensing

Table 7. Ordering Information

Part Number	Description
15454-10GE-XP=	Ethernet 4-10 Gigabit Ethernet XPonder
15454-10GE-XPE=	Ethernet 4-10 Gigabit Ethernet Enhanced XPonder
ONS-XC-10G-xx.x=	OC-192/STM64/10 Gigabit Ethernet, XFP, 15xx.xx (see Table 6), 100 GHz, LC
ONS-XC-10G-S1=	10 Gigabit SFP OC-192/STM-64/10 GE/10-Gbps Fibre Channel , 1310 SR-SM LC connectors
ONS-XC-10G-I2=	XFP - OC192/STM64/10GE - 1550 IR/SH2 - SM LC

Cisco Services

Cisco Services make networks, applications, and the people who use them work better together.

Today, the network is a strategic platform in a world that demands better integration between people, information, and ideas. The network works better when services, together with products, create solutions aligned with business needs and opportunities.

The unique Cisco Lifecycle approach to services defines the requisite activities at each phase of the network lifecycle to help ensure service excellence. With a collaborative delivery methodology that joins the forces of Cisco, our skilled network of partners, and our customers, we achieve the best results.

For More Information

For more information about the Cisco ONS 15454 10 Gigabit Ethernet XPonder card, visit <http://www.cisco.com/en/US/products/hw/optical/ps2006/index.html> or contact your local account representative.



Americas Headquarters
Cisco Systems, Inc.
San Jose, CA

Asia Pacific Headquarters
Cisco Systems (USA) Pte. Ltd.
Singapore

Europe Headquarters
Cisco Systems International BV
Amsterdam, The Netherlands

Cisco has more than 200 offices worldwide. Addresses, phone numbers, and fax numbers are listed on the Cisco Website at www.cisco.com/go/offices.

CCDE, CCENT, Cisco Eos, Cisco Lumin, Cisco Nexus, Cisco StadiumVision, Cisco TelePresence, the Cisco logo, DCE, and Welcome to the Human Network are trademarks; Changing the Way We Work, Live, Play, and Learn and Cisco Store are service marks; and Access Registrar, Aironet, AsyncOS, Bringing the Meeting To You, Catalyst, CCDA, CCDP, CCIE, CCOIP, CCNA, CCNP, CCSP, CCVP, Cisco, the Cisco Certified Internetwork Expert logo, Cisco IOS, Cisco Press, Cisco Systems, Cisco Systems Capital, the Cisco Systems logo, Cisco Unity, Collaboration Without Limitation, EtherFast, EtherSwitch, Event Center, Fast Step, Follow Me Browsing, FormShare, GigaDrive, HomeLink, Internet Quotient, IOS, iPhone, IQ Expertise, the IQ logo, IQ Net Readiness Scorecard, iQuick Study, IronPort, the IronPort logo, LightStream, Linksys, MediaTone, MeetingPlace, MeetingPlace Chime Sound, MGX, Networkers, Networking Academy, Network Registrar, PCNow, PIX, PowerPanels, ProConnect, ScriptShare, SenderBase, SMARTnet, Spectrum Expert, StackWise, The Fastest Way to Increase Your Internet Quotient, TransPath, WebEx, and the WebEx logo are registered trademarks of Cisco Systems, Inc. and/or its affiliates in the United States and certain other countries.

All other trademarks mentioned in this document or Website are the property of their respective owners. The use of the word partner does not imply a partnership relationship between Cisco and any other company. (0807R)