

4-Port 2.5-Gbps Enhanced Muxponder Card for the Cisco ONS 15454 Multiservice Transport Platform

The Cisco® ONS 15454 Multiservice Transport Platform (MSTP) support for a 4-Port 2.5-Gbps 4-Channel Tunable Enhanced Muxponder Card for the Cisco ONS 15454 Multiservice Transport Platform expands the Cisco ONS platform's OC-48/STM-16 interface density. The card facilitates the delivery of transparent 2.5-Gbps-based services for enterprises or metropolitan and regional service provider networks (Figure 1).

Figure 1

4-Port 2.5-Gbps Enhanced Muxponder Card



Background

Metro transport networks must support numerous service demands, from low-rate DS-1/T1, DS-3/E3, 10/100BASE-T, and OC-3/STM-1 to higher-rate OC-12/STM-4, Gigabit Ethernet, OC-48/STM-16, OC-192/STM-64, and 10 Gigabit Ethernet services. In the recent past, SONET add-drop multiplexers (ADMs) provided the services platform to aggregate and transport services up to OC-48/STM-16, whereas metro dense wavelength-division multiplexing (DWDM) platforms were designed for optical signals from OC-3/STM-1 to OC-192/STM-64, including Gigabit and 10 Gigabit Ethernet. Unfortunately, deploying multiple platforms (including metro DWDM and SONET ADMs) to support multiple services is not cost-effective for many service provider and enterprise networks. The Cisco ONS 15454 MSTP with a muxponder card provides a more cost-effective networking solution to enable the delivery of all services, from lower-speed DS-1/E1, high-density 2.5 Gbps, and high-bandwidth OC-192/STM-64.

Product Overview

The Cisco ONS 15454 MSTP 4-Port 2.5-Gbps Enhanced Muxponder Card can transport four OC-48/STM-16 payloads over a G.709 OTU-2-based, 100-GHz spaced, 50-GHz stabilized, ITU-compliant wavelength with selectable Enhanced Forward Error Correction (E-FEC). The muxponder card is a plug-in module to the Cisco ONS 15454 MSTP, enabling a high-density, cost-effective solution for OC-48/STM-16 services transport over a platform capable of low-rate services down to 1.5 Mbps. The muxponder card architecture contains four client interfaces that are mapped to a single line interface, without accessing the Cisco ONS 15454 shelf cross-connect fabric.

Each client interface provides a 2.488-Mbps (OC-48/STM-16) SONET/SDH interface through a Small Form-Factor Pluggable (SFP) optics module with LC connectors, providing the flexibility to support several optical reaches, including short-reach/intra-office, intermediate-reach/short-haul, and long-reach/long-haul. The muxponder card supports any mixture of SFP reach types and also supports in-service insertion or removal without affecting other active ports, allowing superior networking flexibility and reduced pre-planning activities.

The DWDM line interface provides one 10.70923-Gbps G.709 OTU-2 digital wrapper, long-reach/long-haul, ITU-compliant, 100-GHz spaced optical interface using LC connectors supporting G.709 OTU-2 digital wrapper interfaces. The DWDM output line interface is tunable across four adjacent 100-GHz wavelengths, reducing inventories for spares. When operated within the outlined specifications, each card will transport the 10-Gbps signal with a maximum bit error rate (BER) of 10E-15.

The muxponder card incorporates the four clients and one DWDM line interface on the same card. The muxponder cards are deployable in the 12 multiservice interface card slots of the Cisco ONS 15454 platform, in systems with or without cross-connect cards. The addition of a cross-connect card enables the platform to support hybrid applications, containing transparent 2.5-Gbps services as well as aggregation of the other services supported by the Cisco ONS 15454 platform. The only other common card required for operation is the timing, communications, and control (TCC) card.

The muxponder card provides many carrier-class features and capabilities necessary to deliver 2.5-Gbps services, including selectable protocol transparency, wavelength tunability, flexible protection mechanisms, flexible timing options, and management capabilities.

Enhanced FEC Capability

An important feature of the enhanced muxponder card is the ability to configure the Forward Error Correction (FEC) in three modes: NO FEC, FEC, and E-FEC. The output bit rate will be always 10.7092 Gbps as defined in G.709 but the error-coding performance can be provisioned:

- NO FEC: no Forward Error Correction
- FEC: standard G.975 Reed-Salomon algorithm
- E-FEC: standard G.975.1 two orthogonally concatenated BCH super FEC code. This FEC scheme contains three parameterizations of the same scheme of two orthogonally interleaved block codes (BCH). The constructed code is decoded iteratively, to achieve the expected performance.

E-FEC gains 2 dB respect standard FEC.

Selectable Protocol Transparency

The muxponder card provides the capability to deliver “transparent” 2.5-Gbps wavelength services, OC-48/STM-16 terminated signals, and a high-density solution for cost-effective, point-to-point SONET/SDH payload transport for the Cisco ONS 15454 platform. The card is provisionable to either pass all the SONET/SDH overhead bytes transparently or to terminate the line and section overhead. In transparent mode, client terminal equipment interconnected over a muxponder-card-based circuit can communicate over the section/multiplexer section data communications channel (SDCC/MSDCC), can signal 1+1 and bidirectional line switched ring/multiplex section shared protection ring (BLSR/MS-SPR) protection switching using the K1 and K2 bytes, and can support provisionable section trace capabilities over the J0 byte. In addition, the muxponder circuit, whether provisioned in transparent or terminating mode, can support unidirectional path switched ring/subnetwork connection protection (UPSR/SNCP)-based client circuits. Full transparency is guaranteed by the enhanced multiplex engine that performs the multiplexing of the incoming 2.5-Gbps signal at the OTN layer that is no longer in the SONET/SDH domain. Each of the 4 x OC-48/STM-16 streams are mapped into a fully standard ODU-1 encapsulation and then the 4 x ODU-1 streams are multiplexed into an ODU-2 envelope to be transmitted in a fully standard G.709 OTU-2 format.

The client interfaces can support nonconcatenated SONET/SDH payloads on an STS-1, VC-4, VC-12, and VT1.5 basis, as well as concatenated SONET/SDH payloads (STS-Nc, N = 3, 6, 9, 12, 24, or 48; or VC-4-Mc, M = 1, 2, 3, 4, 8, or 16).

Wavelength Tunability

The muxponder cards operate on the 100-GHz ITU grid and are tunable across four adjacent 100-GHz channels per card. The incorporation of tunability into the muxponder cards reduces the customer’s inventory required to cover all the system wavelengths.

Flexible Protection Mechanism Support

The muxponder card, depending upon the requirement of the network, can be deployed to support the many protection mechanisms found in optical transport networks. Table 1 outlines the supported protection options that help to deliver the service-level agreements (SLAs) required by the application.

Table 1. Protection Formats

Protection Type	Capabilities	Figure
Unprotected	Offers no client terminal interface, muxponder card, or DWDM line protection. The client signal is transported over a single unprotected muxponder card.	Figure 2
1+1 protection or UPSR/SNCP and BLSR/MSP-SPR	Provides protection for the client terminal interface, muxponder card, and DWDM line protection through client automatic protection switching/linear multiplex section protection (APS/LMSP) signaling transported transparently over the muxponder card.	Figure 3
	Similar to unprotected format. Protection is provided through client line or path protection via transparent signal transport through muxponder circuit.	Figure 4
Y-cable protection	Provides muxponder card and DWDM line protection without requiring client terminal equipment interface protection. Uses Y-protection device to optically split a single client interface to two muxponder cards. The Cisco ONS 15454 system controls the muxponder card active/standby status to provide a single signal feed to client equipment.	Figure 5

Figure 2
Unprotected

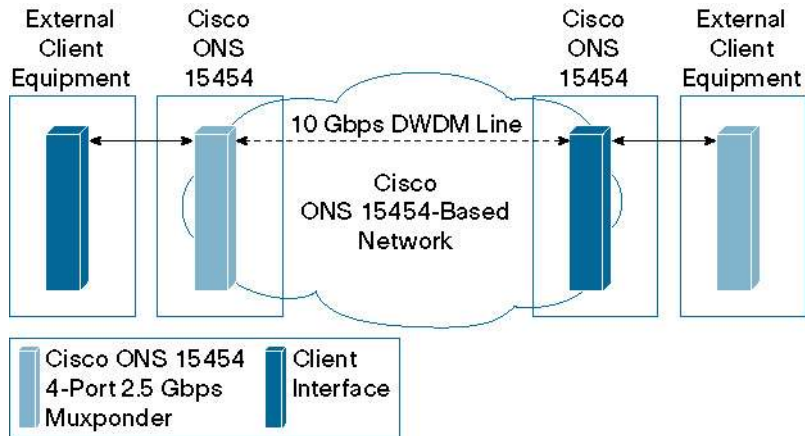

Figure 3
1+1 Protection

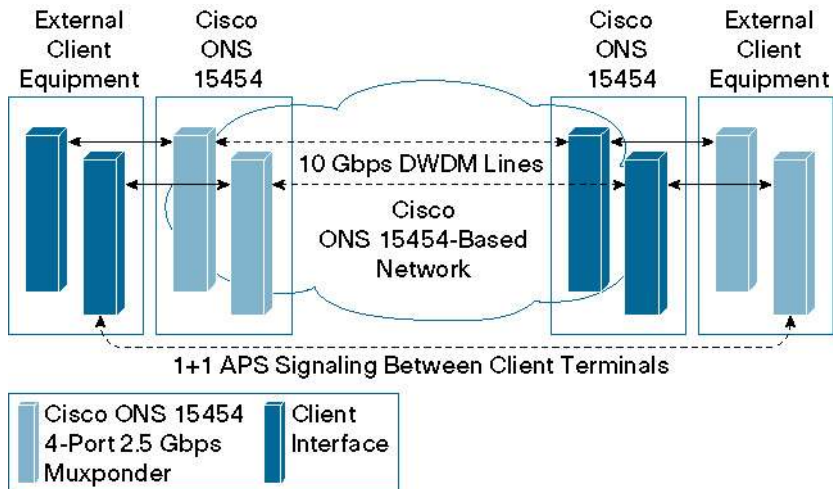

Figure 4
 UPSR/SNCP and BLSR/MSP-SPR Protection

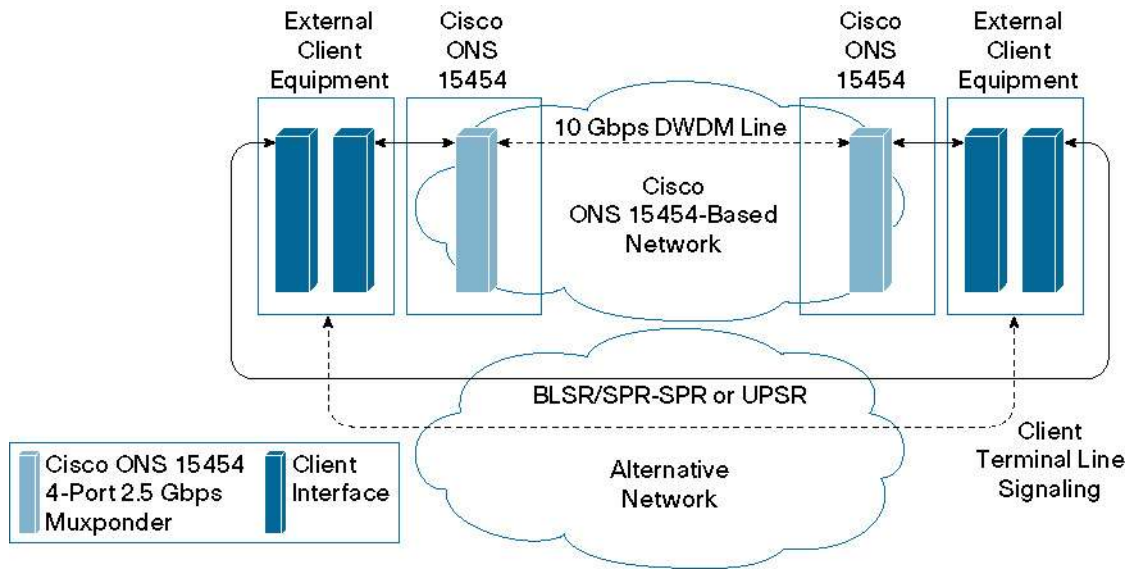
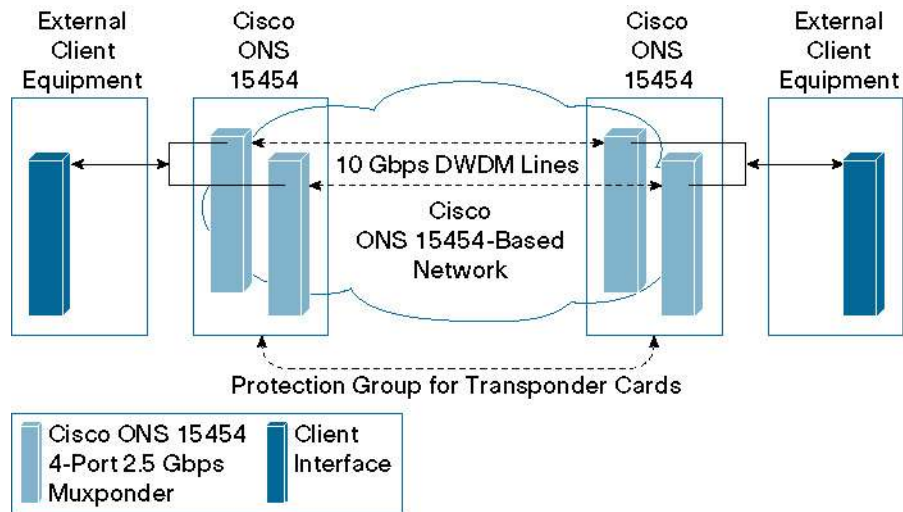

Figure 5
 Y-Cable Configuration



Flexible Timing Options

The muxponder card times the client side and the DWDM line optical transmitter port with the clock derived by the shelf processor. The Cisco ONS 15454 platform provides the option to recover timing signals for node-timing reference, with sync status messaging support, from any of the four client optical interfaces, in addition to the standard options of using an external clock derived from a building integrated timing supply (BITS) clock or another optical interface card on the Cisco ONS 15454 system. The muxponder card can also maintain synchronization from one of the available clients even if both the shelf processors (active and standby) fail.

Management

The Cisco ONS 15454 MSTP provides comprehensive management capabilities for operations, administration, monitoring, and provisioning (OAM&P) accessed through the integrated Cisco Transport Controller craft interface with support from the Cisco Transport Manager element management system (EMS). The muxponder card incorporates provisionable digital wrapper (G.709) functions, providing DWDM wavelength performance-management capabilities, especially for services being transported transparently across the network. Without the digital wrapper function, a carrier transporting a service transparently would be unable to identify network impairments that may degrade the transported signal and exceed SLA requirements. The digital wrapper's general communication channel (GCC) enables a separate communications channel, versus the section DCC/regenerator section DCC (SDCC/RSDCC) in SONET/SDH signals, to be used by the platform when transparent signals are transported. This GCC enables the Cisco ONS 15454 to extend its advanced network autodiscovery capabilities to DWDM-based services. The integrated Cisco Transport Controller craft manager and the Cisco Transport Manager EMS provide the user with OAM&P access for the system.

Configurable Far-End-Laser-Off Behavior

The Enhanced Muxponder Card offers the capability to provision the Far-End-Laser-Off behavior. You can use Cisco Transport Controller to configure how the remote client interface will behave following a fault condition. It is possible to configure the remote client to squelch or to send an alarm indication signal (AIS).

Performance Monitoring

The performance monitoring capabilities of the muxponder card provide support for both transparent and nontransparent signal transport. For SONET/SDH signals, standard performance monitoring, threshold-crossing conditions, and alarms are supported per Telcordia GR-474 and GR-2918, as well as ITU G.783 and ETS 300 417-1 standards. Each digital wrapper channel will be monitored per G.709 (OTN). Optical parameters on the client and DWDM line interfaces are supported, including loss of signal (LOS), laser bias current, transmit optical power, and receive optical power. Calculation and accumulation of the performance monitoring data is in 15-minute and 24-hour intervals as per G.7710.

The muxponder card incorporates faceplate-mounted LEDs to provide a quick visual check of the operational status of the card. An orange circle is printed on the faceplate, indicating the shelf slot in which the card can be installed.

Application Description

The muxponder card adds the capability to cost-effectively aggregate 2.5-Gbps services and transport them with or without overhead transparency. Figure 6 displays a typical service provider backbone network application. The muxponder card on the Cisco ONS 15454 network will enable the transport of the four services or termination of the SONET/SDH overhead of the 4 streams, or it is possible to have them transparently pass through service provider A's network.

Figure 6
High-Density OC-48/STM-16 Transport

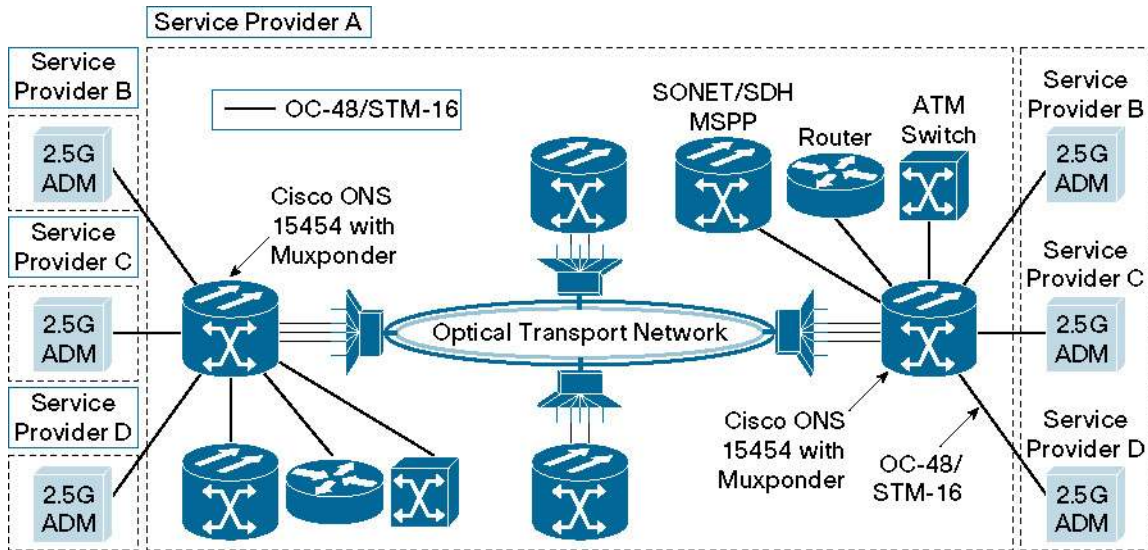

As well as transporting 2.5-Gbps service, the user can deliver a mixture of service types, from DS-1/E1 to 10-Gbps services using a common Cisco ONS 15454 transport platform, reducing system complexity, capital expenditures, and operational expenses related to technician training.

The Cisco Advantage

The muxponder card complements and extends the service capabilities of the Cisco ONS 15454 MSTP. It allows users to take advantage of their existing fiber plant and installed base of Cisco ONS 15454 systems, while providing the required services, such as DS-1/E1, DS-3/E3, OC-n/STM-n, Ethernet, ATM, and video over the same Cisco ONS 15454 platform. The muxponder solution improves the Cisco ONS 15454 platform's 2.5-Gbps service densities while reducing the networking costs associated with the typical deployment option of an overlay metro DWDM platform to transport a mixture of services (Figures 7 and 8).

Figure 7
Today's DWDM Architecture

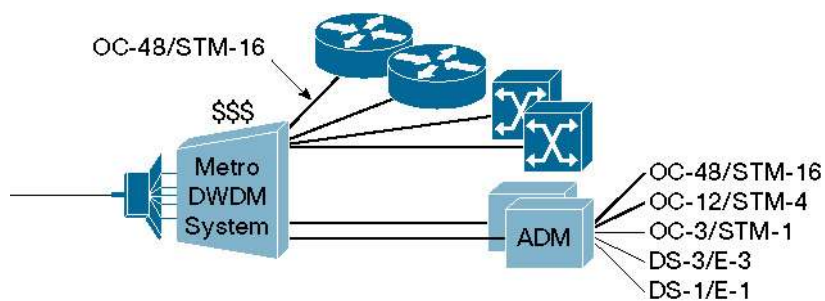
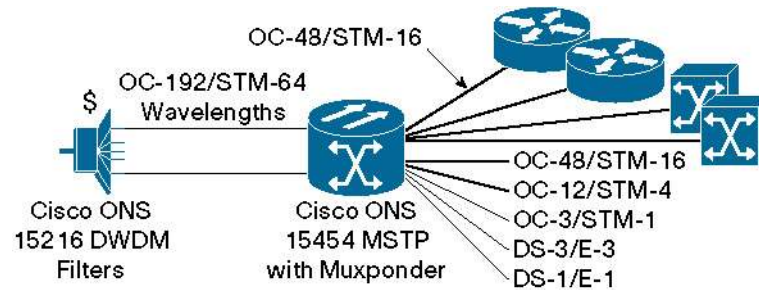

Figure 8

Cisco ONS 15454/ONS 15216 Hybrid DWDM Architecture



The Cisco ONS 15454 optical transport solution offers significant advantages over traditional network elements offering 10-Gbps interfaces, including the following:

Unprecedented Service Densities

The Cisco ONS 15454 platform supports up to 48 2.5-Gbps interfaces per shelf. When the platform is installed in a typical central office bay frame, a bay can support up to 192 2.5-Gbps interfaces. These industry-leading densities are attainable because of the single-slot footprint of the muxponder interface card.

Multiple Restoration Types

The Cisco ONS 15454 platform supports 2- or 4-fiber BLSR/MS-SPR, UPSR/SNCP, linear APS/MSP, and path-protected mesh networking (PPMN). This allows the service provider to deploy the platform in all areas of the transport networking applications, including the interoffice network, normally deployed using 2- or 4-fiber BLSR/MS-SPR restoration, as well as the collector or fiber to the building networks, normally using UPSR/SNCP restoration.

Common Line Cards

Optical line cards are not restoration-type-dependent, which reduces sparing costs and technician confusion. Additionally, as networks and customer interface demands evolve, you can easily redeploy optical circuit packs as necessary.

Single Software Load

One software load supports all of the restoration types listed previously, eliminating unnecessary guesswork when ordering. No software right-to-use license is required for each protection type. After the software is purchased, all features with full functionality are available to the user.

Common Chassis

A common chassis supporting all optical interface speeds allows the technician to spend time deploying bandwidth and services instead of learning about multiple equipment platforms. Many equipment vendors offer optical line-speed specific platforms (OC-3/STM-1, OC-12/STM-4, DWDM, and so on) and categorize platforms by restoration mechanisms (UPSR/SNCP, 2F-BLSR/MS-SPR, and 4F-BLSR/MS-SPR). This not only causes ordering confusion, but brings into question whether the inventoried equipment will accommodate the functionality required to support the desired application. The Cisco ONS 15454 platform's line-rate and restoration flexibility makes

ordering and deploying simple, fast, and easy. With integrated DWDM capabilities, the need to deploy another metro-DWDM platform is reduced.

Multiservice Interface Selection

DS-1/E1 through OC-192/STM-64, Ethernet, Fast Ethernet, Gigabit Ethernet, and 10 Gigabit Ethernet interfaces are all supported. This eliminates the “missing interface” found with many vendors’ bit-rate-specific product offerings.

The Cisco ONS 15454, the industry’s leading metro optical transport platform, delivers supercharged SONET/SDH transport, integrated optical networking, unprecedented multiservice interfaces, and competitive economic benefits.

Cisco ONS 15454 4-Port 2.5-Gbps Muxponder Card Features and Specifications

Compact Design

- Single-width card slot design for high-density, 2.5-Gbps solutions
- Up to 12 muxponder cards per shelf assembly enables up to 192 2.5-Gbps interfaces per bay frame

Flexible Restoration Options

- Transparent APS/LMSP, UPSR/SNCP, and BLSR/MSP-SPR
- Unprotected (1+0)
- Client Y-protection option

Regulatory Compliance¹

Tables 2 and 3 list the regulatory compliance and system requirements for the muxponder card. Tables 4 and 5 list product specifications and ordering information.

Table 2. Regulatory Compliance

Countries Supported	
<p>SONET/ANSI System</p> <ul style="list-style-type: none"> • Canada • United States • Mexico • Korea • Japan • European Union 	<p>SDH/ETSI System</p> <ul style="list-style-type: none"> • European Union • Australia • New Zealand • Singapore • China • Mexico • Hong Kong • Korea
<p>EMC (Class A)</p> <ul style="list-style-type: none"> • ICES-003 Issue 3, 1997 • GR-1089-CORE, Level 3 • 47CFR15 	<ul style="list-style-type: none"> • EN 300 386-TC • CISPR22, CISPR24 • EN55022, EN55024

¹ All compliance documentation may not be completed at the time of product release. Please check with your Cisco sales representative for countries outside of Canada, the United States, and the European Union.

Safety	
<ul style="list-style-type: none"> CAN/CSA-C22.2 No.950-95, Third Edition GR-1089-CORE 	<ul style="list-style-type: none"> UL 60950 IEC 60950/EN60950, Third Edition
Laser	
<ul style="list-style-type: none"> UL 60950 IEC60950/EN60950 IEC 60825-2 (2000) 	<ul style="list-style-type: none"> CDRH (Accession letter and report) IEC 60825-1 Am.2 (2001)
Environmental	
<ul style="list-style-type: none"> GR-63-CORE, Level 3 ETS 300-019-2-1 (Storage, Class 1.1) 	<ul style="list-style-type: none"> ETS 300-019-2-2 (Transportation, Class 2.3) ETS 300-019-2-3 (Operational, Class 3.1E)
Optical	
<ul style="list-style-type: none"> GR-253-CORE G.691 	<ul style="list-style-type: none"> G.709 G.975
Quality	
<ul style="list-style-type: none"> TR-NWT-000332, Issue 4, Method 1 calculation for 20-year mean time between failure (MTBF) 	
Miscellaneous	
<ul style="list-style-type: none"> AT&T Network Equipment Development Standards (NEDS) Generic Requirements, AT&T 802-900-260, Issue 3, December 1999 SBC TP76200MP, May 2003 	<ul style="list-style-type: none"> Verizon SIT.NEBS.NPI.2002.010, October 2002 Worldcom ESD requirement

Table 3. System Requirements

Component	Cisco ONS 15454 ANSI	Cisco ONS 15454 ETSI
Processor	TCC2P/TCC2	TCC2P/TCC2
Cross-connect	All (not required)	All (not required)
Shelf assembly	15454-SA-HD or 15454-SA-HD-DDR shelf assembly with FTA3 version fan-tray assembly	15454-SA-ETSI shelf assembly with SDH 48V fan-tray assembly
System software	Release 4.7 or greater	Release 4.7 or greater
Slot compatibility	1–6, 12–17	1–6, 12–17

Table 4. Client Side Specifications

Specification	Short Reach/Intra-office	Intermediate Reach/Short Haul	Long Reach/Long Haul
Client Interface (SFP)			
Type	SFP	SFP	SFP
Specification			
Telcordia GR-253-Core	GR-253-Core SR-1	GR-253-Core IR-1	GR-253-Core LR-2
ITU	I-16.1	S-16.1	L-16.2
Optical Path Attenuation	0 to 7 dB	0 to 12 dB	0 to 7 dB
Wavelength, nominal, (I_{Tnom})	1310 nm	1310 nm	1550 nm
Spectral range (I_{Tmin} to I_{Tmax})	1266 to 1360	1260 to 1360 nm	1500 to 1580
Spectral width @ 20 dB ($\Delta\lambda_{20}$)	—	1 nm	1 nm

Specification	Short Reach/Intra-office	Intermediate Reach/Short Haul	Long Reach/Long Haul
Maximum RMS width (σ)	4 nm	—	—
Optical transmitter			
Type	Fabry-Perot	Distributed feedback /Direct Modulation (DFB/DM)	Distributed feedback /Direct Modulation (DFB/DM)
Output power (P_{Tmin} to P_{Tmax})	-10 to -3	-5 to 0 dBm	-3 to +2 dBm
Extinction ratio, minimum (r_{eminx})	8.2 dB	8.2 dB	8.2 dB
Laser safety class	1	1	1
Optical receiver			
Type	PIN	PIN	APD
Sensitivity @ BER (P_{Rmin} to P_{Rmax})	-18 to -3 dBm	-18 to 0 dBm	-28 to -9 dBm
Chromatic dispersion tolerance (D_{SRmax})	12 ps/nm	—	1200 to 1600 ps/nm
Power penalty (P_o)	1	1	2
BER, maximum (BER_{min})	10E-12	10E-12	10E-12
Receiver reflectance (maximum)	-27 dB	-27 dB	-27 dB
Input wavelength bandwidth ($I_{c,rx}$)	1266 to 1580 nm	1260 to 1580 nm	1500 to 1580 nm
Connector type (Tx/Rx)	LC	LC	LC

Table 5. DWDM Specifications

Specification	DWDM Line Interface
DWDM Line Interface	
Bit Rate	10.7092 ±100 ppm Gbps
Automatic laser shutdown and restart	ITU-T G.664 (06/99)
Nominal wavelength (λ_{Tnom})	Four-channel tunable (C-band – Table 8)
Spectral width @ 20 dB ($_20$)	≤25 GHz
Optical transmitter	
Type	Lithium niobate external modulator
Output power (P_{Tmin} to P_{Tmax})	+3 dBm, +6 dBm
Required optical return loss, minimum (ORL _{min})	27 dB
Extinction ratio, minimum (r_{eminx})	>10.5 dB
Laser safety class	1
Optical receiver	
Type	Avalanche photo diode (APD)
Reflectance between far-end Tx and near-end Rx (maximum)	-27 dB
Receiver reflectance (maximum)	-14 dB
Input wavelength bandwidth ($I_{c,rx}$)	1290 nm to 1605 nm
Connector type (Tx/Rx)	LC, duplex (shuttered)

Table 6. DWDM Receive Side Optical Performances

OSNR	FEC Type	Pre-FEC BER	Post-FEC BER	Input Power Sensitivity	CD Tolerance
23 dB	OFF	<10E(-12)	–	–8 to –20 dBm	±1200 ps/nm
19 dB	OFF	<10E(-12)	–	–8 to –20 dBm	±1000 ps/nm
19 dB	OFF	<10E(-12)	–	–8 to –22 dBm	–
10 dB	STD	<10E(-5)	<10E(-15)	–8 to –18 dBm	±800 ps/nm
8 dB	STD	<10E(-5)	<10E(-15)	–8 to –18 dBm	–
8 dB	ENH	<7x10E(-4)	<10E(-15)	–8 to –18 dBm	±800 ps/nm
7 dB	ENH	<7x10E(-4)	<10E(-15)	–8 to –18 dBm	–

Table 7. Card Specifications

Specification	
Management	
Card LEDs	
Failure (FAIL)	Red
Active/standby (ACT/STBY)	Green/yellow
Signal fail (SF)	Yellow
Client Port LEDs (per port)	
Active input signal	Green
DWDM Port LEDs	
Active input signal	Green
Output wavelength	Green
Power	
Card power draw (including SFPs)	
Typical	40W
Maximum	50W
Operating Environment	
Temperature	23 to 131 F (–5 to 55°C)
Humidity	5 to 95 percent noncondensing
Storage Environment	
Temperature	–40 to 185 F (–40 to 85°C)
Humidity	5 to 95 percent noncondensing

Table 8. Wavelength Channel Plan for Muxponder Cards

Card (xx.x)	λ (nm)	Card (xx.x)	λ (nm)	Card (xx.x)	λ (nm)	Card (xx.x)	λ (nm)
30.3	1530.33	38.1	1538.19	46.1	1546.12	54.1	1554.13
	1531.12		1538.98		1546.92		1554.94
	1531.90		1539.77		1547.72		1555.75
	1532.68		1540.56		1548.51		1556.55
34.2	1534.25	42.1	1542.14	50.1	1550.12	58.1	1558.17
	1535.04		1542.94		1550.92		1558.98
	1535.82		1543.73		1551.72		1559.79
	1536.61		1544.53		1552.52		1560.61

Table 9. Ordering Information

Part Number	Description
15454-10ME-xx.x	4-Port OC-48/STM-16 EFEC muxponder card, 4 SFP-based client interfaces, 4-channel tunable on 100-GHz ITU wavelengths (50-GHz stability) DWDM line with LC connectors – C band
15454-SFP-OC48-IR= 15454E-SFP-L.16.1=	OC-48/STM-16 SFP, intermediate-reach, 1550-nm, single-mode, LC connectors
ONS-SE-2G-S1=	OC-48/STM-16 SFP optics module, short-reach/intra-office, 1310-nm, single-mode, EXT temperature range, LC connectors
ONS-SE-2G-L2=	OC-48/STM-16 SFP optics module, long-reach/long-haul, 1550-nm, single-mode, EXT temperature range, LC connectors

**Corporate Headquarters**

Cisco Systems, Inc.
170 West Tasman Drive
San Jose, CA 95134-1706
USA
www.cisco.com
Tel: 408 526-4000
800 553-NETS (6387)
Fax: 408 526-4100

European Headquarters

Cisco Systems International BV
Haarlerbergpark
Haarlerbergweg 13-19
1101 CH Amsterdam
The Netherlands
www-europe.cisco.com
Tel: 31 0 20 357 1000
Fax: 31 0 20 357 1100

Americas Headquarters

Cisco Systems, Inc.
170 West Tasman Drive
San Jose, CA 95134-1706
USA
www.cisco.com
Tel: 408 526-7660
Fax: 408 527-0883

Asia Pacific Headquarters

Cisco Systems, Inc.
168 Robinson Road
#28-01 Capital Tower
Singapore 068912
www.cisco.com
Tel: +65 6317 7777
Fax: +65 6317 7799

Cisco Systems has more than 200 offices in the following countries and regions. Addresses, phone numbers, and fax numbers are listed on **the Cisco Website at www.cisco.com/go/offices.**

Argentina • Australia • Austria • Belgium • Brazil • Bulgaria • Canada • Chile • China PRC • Colombia • Costa Rica
Croatia • Cyprus • Czech Republic • Denmark • Dubai, UAE • Finland • France • Germany • Greece • Hong Kong SAR
Hungary • India • Indonesia • Ireland • Israel • Italy • Japan • Korea • Luxembourg • Malaysia • Mexico
The Netherlands • New Zealand • Norway • Peru • Philippines • Poland • Portugal • Puerto Rico • Romania • Russia
Saudi Arabia • Scotland • Singapore • Slovakia • Slovenia • South Africa • Spain • Sweden • Switzerland • Taiwan
Thailand • Turkey • Ukraine • United Kingdom • United States • Venezuela • Vietnam • Zimbabwe

All contents are Copyright © 1992–2005 Cisco Systems, Inc. All rights reserved. Cisco, Cisco Systems, and the Cisco Systems logo are registered trademarks or trademarks of Cisco Systems, Inc. and/or its affiliates in the United States and certain other countries.

All other trademarks mentioned in this document or Website are the property of their respective owners. The use of the word partner does not imply a partnership relationship between Cisco and any other company. (0502R) Pa/LW9883 12/05

