

DATA SHEET

10-GBPS MULTIRATE TRANSPONDER CARD FOR THE CISCO ONS 15454 MULTISERVICE TRANSPORT PLATFORM

Figure 1
Cisco ONS 15454 10-Gbps
Multirate Transponder Card



The Cisco® ONS 15454 Multiservice Transport Platform (MSTP) support for a 10-Gbps multirate transponder card simplifies the integration and transport of 10 Gigabit Ethernet, OC-192, and STM-64 interfaces and services into enterprises or metropolitan and regional service provider networks (Figure 1).

BACKGROUND

Metropolitan (metro) transport networks must support numerous service demands, from low-rate DS-1/E1, DS-3/E3, 10/100BASE-T, and OC-3/STM-1, to higher-rate OC-12/STM-4, Gigabit Ethernet, OC-48/STM-16, and 10 Gigabit Ethernet services. In the recent past, SONET add/drop multiplexers (ADMs) provided the services platform to aggregate and transport services up to OC-48/STM-16, where metro dense wavelength-division multiplexing (DWDM) platforms were designed for optical signals from OC-3/STM-1 to OC-192/STM-64, including Gigabit Ethernet and 10 Gigabit Ethernet. Unfortunately, deploying multiple platforms (including metro DWDM and SONET ADMs) to support the wide variety of services is not cost effective for many service provider and enterprise networks. The Cisco ONS 15454 MSTP with a 10-Gbps transponder card provides a more cost-effective networking solution for the delivery of all services, from lower-speed DS-1/E1 to higher-speed 10 Gigabit Ethernet and OC-192/STM-64.

PRODUCT OVERVIEW

The 10-Gbps Multirate Transponder card for the Cisco ONS 15454 MSTP can transport 10 Gigabit Ethernet, SONET OC-192, and SDH STM-64 services over a 100-GHz spaced, 50-GHz stabilized, ITU-compliant wavelength. The transponder card is a plug-in module to the Cisco ONS 15454 MSTP, providing a cost-effective architecture for delivering high-rate 10-Gbps services as well as low-rate services down to 1.5 Mbps. The transponder card architecture contains a single client interface that is mapped to a single line interface, without accessing the Cisco ONS 15454 shelf cross-connect fabric.

The client interface supports 10 Gigabit Ethernet LAN physical layer, 10 Gigabit Ethernet WAN physical layer, SONET OC-192, and SDH STM-64 signals. The OC-192/STM-64 interface to the client is a short-reach/intraoffice, 1310-nanometer (nm) optical interface using LC connectors supporting fiber distances of up to 2 kilometers (km) with or without the Y-protection option.

The line interface provides one 10-Gbps, long-reach, ITU-compliant, 100-GHz-spaced optical interface using LC connectors supporting OC-192, STM-64, 10 Gigabit Ethernet LAN physical-layer, or 10 Gigabit Ethernet WAN physical-layer interfaces. The DWDM output-line interface is tunable across two adjacent 100-GHz wavelengths, allowing support for 32-channel DWDM networks via 16 discrete card types. Using amplification and dispersion compensation, the transponder card is capable of a 800-km reach. When operated within the outlined specifications each card will transport the 10-Gbps signal with a maximum bit error rate (BER) of 10E-15.

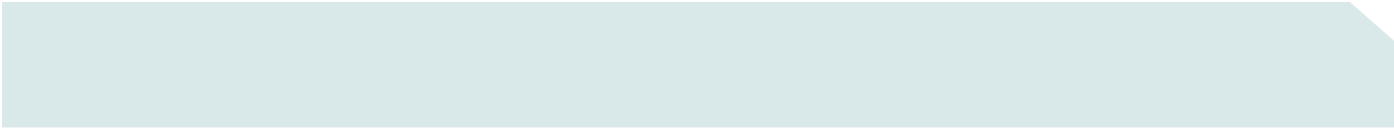

The transponder card incorporates both a client and DWDM line interface on the same card. The transponder cards are deployable in the 12 multiservice interface card slots of the Cisco ONS 15454 MSTP in systems with or without cross-connect cards. The addition of a cross-connect card allows the platform to support hybrid applications, containing transparent 10-Gbps services as well as aggregation of other services supported by the Cisco ONS 15454. The only required common card is the appropriate timing, communications, and control card.

The transponder card provides many carrier-class features and advanced capabilities necessary to deliver 10-Gbps services, including the protocol transparency, wavelength tunability, flexible protection mechanisms, flow-through timing, management, and performance monitoring capabilities outlined below.

Protocol Transparency

The transponder card provides transparent wavelength services on the Cisco ONS 15454 MSTP. For SONET- or SDH-based client payloads, when provisioned in transparent operating mode, the card will pass all of the SONET/SDH overhead bytes transparently. The card monitors important SONET/SDH overhead bytes, such as B1 (section BIP-8) and J0 (section trace), to allow fault-isolation and performance-monitoring capabilities. Termination of the line data communications channel (LDCC) is user-provisionable, to enable the platform processor to route the DCC information for intracarrier networking or to allow the DCC information to be transported untouched, via the digital wrapper's general communications channel (GCC), for intercarrier networking. For 10 Gigabit Ethernet and OC-192/STM-64 payloads, digital wrapper technology (G.709) is used to add a management wrapper to the service, allowing the transponder card to transparently forward the payload while enabling performance metrics to be derived to help ensure circuit service quality.

The cards are transparent to the embedded payload and do not access the Cisco ONS 15454 platform's cross-connect. They can carry any type of concatenated SONET/SDH payloads (STS-Nc or VC-4-Mc), nonconcatenated payloads on an STS-1, VC-4, VC-3, VC-12, or VT1.5 basis, and 10 Gigabit Ethernet LAN or WAN physical-layer payloads.

Wavelength Tunability

The transponder cards operate on the 100-GHz ITU grid and are tunable across two adjacent 100-GHz channels per card. The incorporation of tunability into the transponder card reduces the customer's inventory required to cover all of the wavelengths for deployment and spares.

Flexible Protection Mechanisms

The transponder card provides flexible protection capabilities for both client and DWDM line interfaces, facilitating support for numerous network configurations required to deliver the various service-level agreements (SLAs) required by the customer application (Table 1).

Table 1. Protection Formats

Protection Type	Capabilities	Figure
Unprotected client and line	No client terminal interface, transponder card, or DWDM line protection. The client signal is transported over a single unprotected transponder card. This configuration is suitable for transporting client payloads over a DWDM network that is being protected via unidirectional-path switched ring/subnetwork connection protection (UPSR/SNCP) or bidirectional line switched ring/multiplex section shared protection ring (BLSR/MS-SPR) protocols.	2
1+1 protected client	Facilitates protection for both the client-terminal interfaces and the transponder cards. Two client-terminal interfaces operating 1+1 automatic protection switching/multiplex section protection (APS/MSP) switching are passed through two transponder cards, with switching managed between client-terminal equipment interfaces.	3
Y-cable client interface	Provides transponder-equipment protection without client-terminal equipment-interface protection. A single client interface is split to two transponder cards using a Y-protection device.	4

Figure 2
Unprotected Configuration

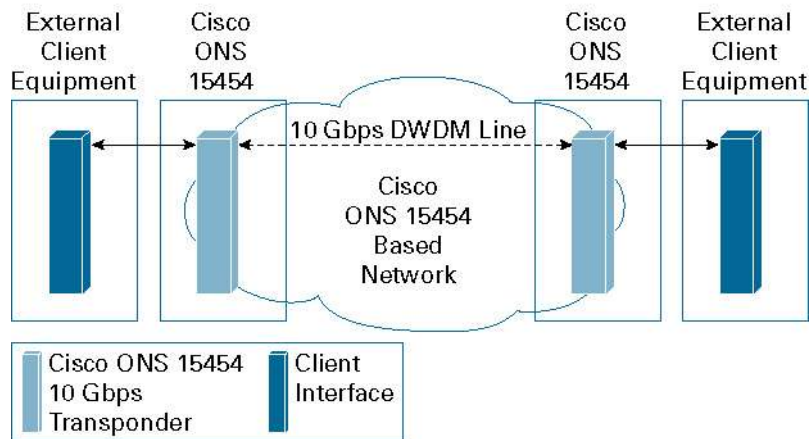

Figure 3
1+1 Configurations

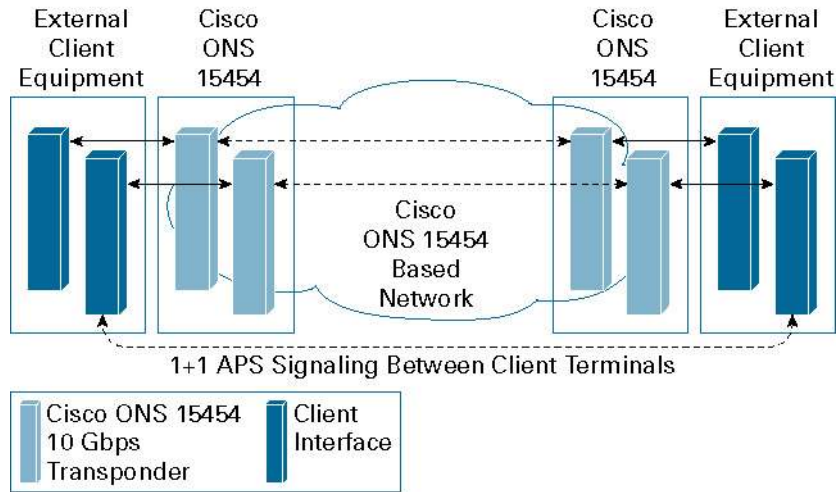
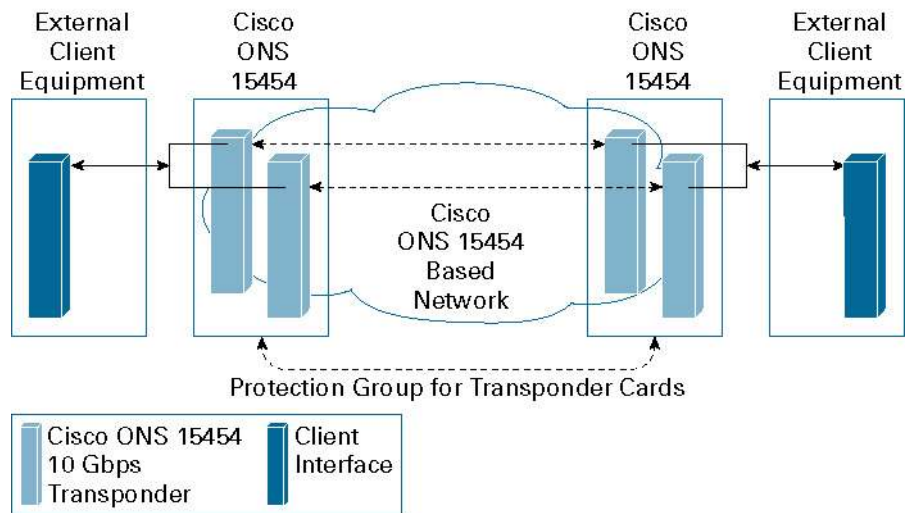

Figure 4
Y-Cable Configuration



Flow-Through Timing

The transponder card allows the timing to “flow through” from client to line optical interfaces. Receive timing from one interface (client or line) is used to time the other transmitter interface (line or client). This flow-through timing enables the transported signal to remain independent from the node timing.

Management

The Cisco ONS 15454 provides comprehensive management capabilities to support the operations, administration, monitoring, and provisioning (OAM&P) capabilities through the integrated Cisco transport-controller craft interface with support from the Cisco transport-manager element management system (EMS). The transponder card incorporates provisionable digital wrapper (G.709) functions, providing per-wavelength performance-management capabilities, especially for services being transported transparently across the network. Without the digital-wrapper functions, a carrier transporting a service transparently would be unable to identify network impairments that may degrade the transported signal and exceed SLA requirements. The digital wrapper’s GCC enables a separate communications channel on a per-wavelength basis, versus the section DCC/regenerator section DCC (SDCC/RSDCC) in SONET/SDH signals that is used by the platform when transparent signals are transported. This GCC allows the Cisco ONS 15454 to extend its advanced network autodiscovery capabilities to DWDM-based services. The integrated Cisco ONS 15454 Transport Controller craft manager and the Cisco Transport Manager EMS provide the user with OAM&P access for the system.

Performance Monitoring

The performance-monitoring capabilities of the transponder card provide support for both transparent and nontransparent signal transport. For SONET/SDH-terminated signals, standard performance-monitoring and threshold-crossing conditions and alarms are supported per Telcordia GR-474, GR-2918, ITU G.783, and ETS 300 417-1 standards. For 10 Gigabit Ethernet signals, standard performance parameters for transmit and receive signals are based on RFC 2819. Each digital-wrapper channel is monitored per ITU-T digital wrapper requirements (G.709). Optical parameters on the DWDM line interface are supported, including laser bias, transmit optical power, and receiver optical power. Calculation and accumulation of the performance-monitoring data is in 15-minute and 24-hour intervals.

The transponder cards incorporate faceplate-mounted LEDs to provide a quick visual check of the operational status of the card. An orange circle is printed on the faceplate, indicating the shelf slots where the card can be installed.

APPLICATION DESCRIPTION

The transponder card adds several new applications to an already flexible Cisco ONS 15454 MSTP. Three identified applications include metro 10 Gigabit Ethernet connectivity [Figure 5], STM-64 transport for cable landing service extension [Figure 6], and OC-192/STM-64 transport for carrier’s carrier services [Figure 7].

Metro 10 Gigabit Ethernet Connectivity

With the addition of 10 Gigabit Ethernet on data terminals, the need for service providers to add a 10 Gigabit Ethernet transport service becomes critical to provide a complete metro service portfolio to their customer bases. The transponder card allows service providers to cost-effectively integrate 10 Gigabit Ethernet into their metro service mix over a multiservice network, reducing the need to deploy an overlay metro DWDM platform, and reducing the cost to deploy the service.

Figure 5

Metro 10 Gigabit Ethernet Connectivity

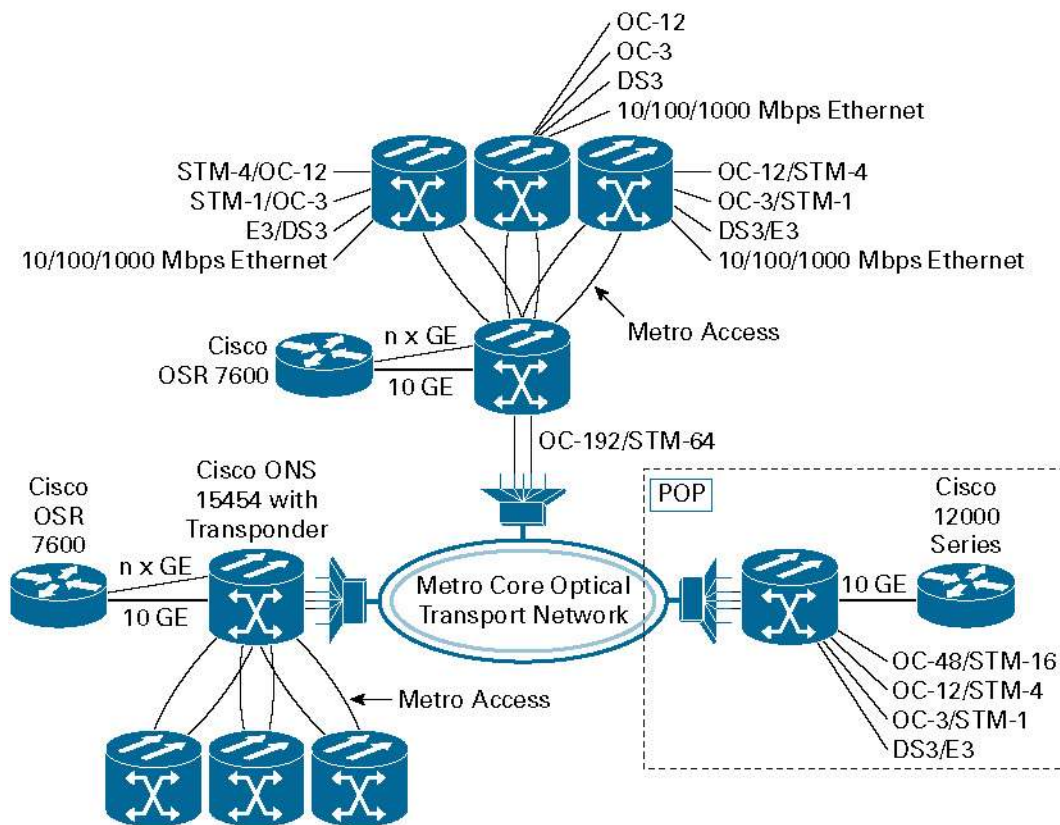

STM-64 Transport for Cable Landing Service Extension

A second application is the capability of a carrier's carrier service provider (Service Provider A) to transport STM-64 payloads from a transoceanic cable-landing site to another service provider's international gateway site (Service Provider B).

Figure 6
 STM-64 Transport for Cable Landing Service Extension

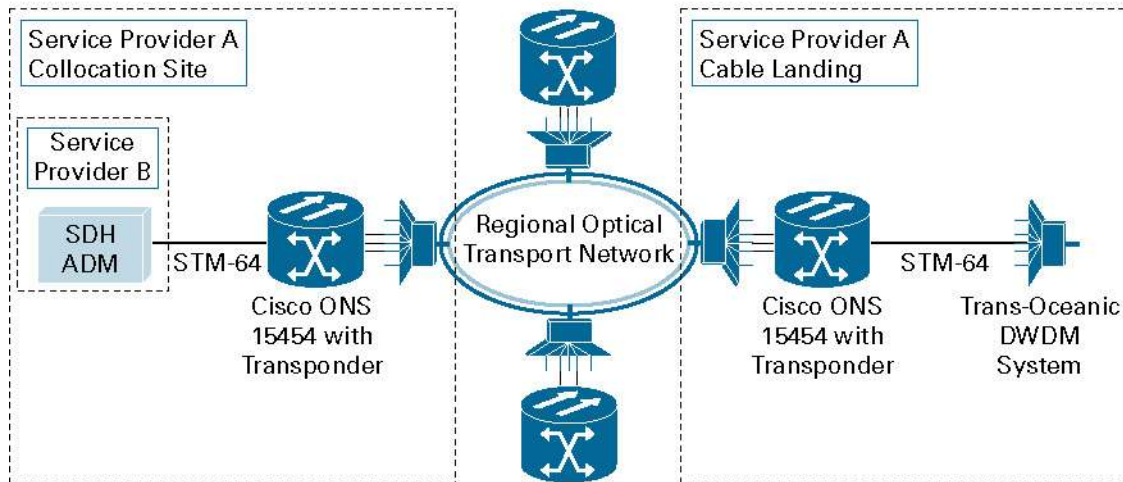

OC-192/STM-64 Transport for Carrier's Carrier Services

The OC-192/STM-64 transport for carrier's carrier services application is similar to the application outlined in Figure 7.

Figure 7
 OC-192/STM-64 Transport for Carrier's Carrier Services

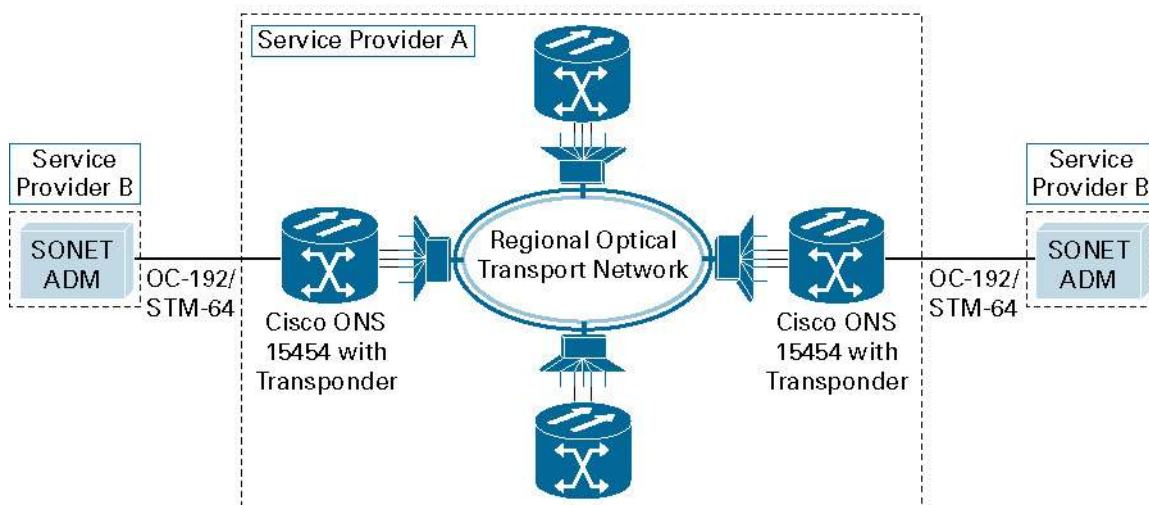

In each of these applications, the user can provide several service types, from DS-1/E1 to 10-Gbps services using a single transport platform, such as the Cisco ONS 15454 MSTP, reducing system complexity, capital expenditures, and operational expenses related to technician training.

THE CISCO ADVANTAGE

The 10-Gbps Multirate Transponder card complements and extends the service capabilities of the Cisco ONS 15454 MSTP. The transponder card enables carriers to take advantage of their existing fiber plant and installed base of Cisco ONS 15454 systems, while providing the required services, such as DS-1/E1, DS-3/E3, OC-n/STM-n, Ethernet, ATM, and video, over the same Cisco ONS 15454 platform. The solution reduces the need to deploy an overlay metro DWDM platform to transport a mixture of services (Figure 8 and Figure 9).

Figure 8

Today's DWDM Architectures

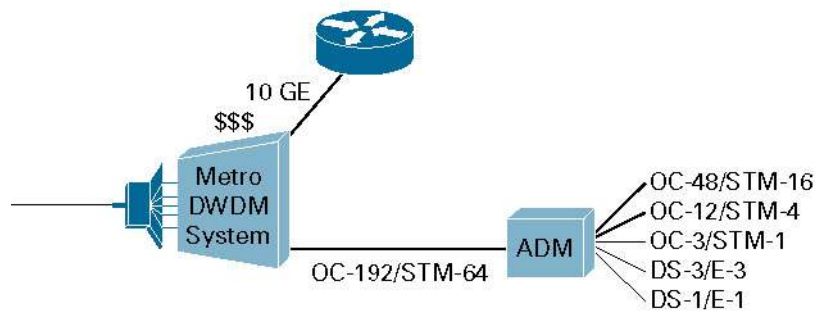
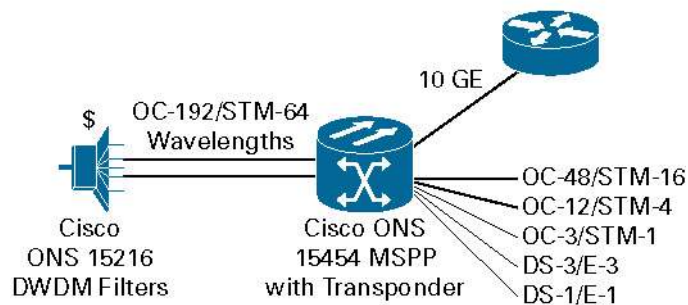

Figure 9

Cisco ONS 15454 Hybrid DWDM Architectures



The Cisco ONS 15454 optical transport solution offers significant advantages over traditional network elements offering 10-Gbps interfaces, including the following.

- Unprecedented Service Densities—The Cisco ONS 15454 MSTP supports up to 12 10-Gbps interfaces per node. When installed in a typical central-office bay frame, a bay can support up to 48 10-Gbps interfaces. These industry-leading densities are attainable due to the single-slot footprint of the transponder interface card.

- **Multiple Restoration Types**—The Cisco ONS 15454 MSTP supports 2- or 4-fiber BLSR/MS-SPR, UPSR/SNCP, linear APS/SNC, and path-protected mesh networking (PPMN). This allows the service provider to deploy the platform in all areas of the transport networking applications, including the interoffice network, normally deployed using 2- or 4-fiber BLSR/MS-SPR restoration, as well as the collector or fiber to the building networks, normally using UPSR/SNCP restoration.
- **Common Line Cards and Chassis**—Optical line cards are not restoration type-dependent, which reduces sparing costs and technician confusion. Additionally, as networks and customer-interface demands evolve, the user has the ability to easily redeploy optical circuit packs as necessary.
- **Single Software Load**—One software load supports all restoration types listed previously, eliminating unnecessary guesswork when ordering. All protection configurations are covered under a single right-to-use software license. After the software is purchased, all features and full functions are available to the user.
- **Common Chassis**—A common chassis supporting all optical-interface speeds allows the technician to spend time deploying bandwidth and services instead of learning about multiple equipment platforms. Many equipment vendors offer optical line speed-specific platforms (such as OC-3/STM-1 or OC-12/STM-4) and categorize platforms by restoration mechanisms (such as UPSR/SNCP, 2F-BLSR/MS-SPR, and 4F-BLSR/MS-SPR). This not only causes ordering confusion, but brings into question whether the inventoried equipment will accommodate the capability required to support the desired application. The Cisco ONS 15454 platform's line-rate and restoration flexibility makes ordering and deploying simple, fast, and easy.
- **Multiservice Interface Selection**—DS-1/E1 through OC-192/STM-64, Ethernet, Fast Ethernet, Gigabit Ethernet, and 10 Gigabit Ethernet interfaces are all supported. This eliminates the “missing interface” found with many vendors' bit rate-specific product offerings.

The Cisco ONS 15454 MSTP, the industry's leading metro optical transport platform, delivers supercharged SONET/SDH transport, integrated optical networking, unprecedented multiservice interfaces, and competitive economic benefits.

CISCO ONS 15454 10-GBPS MULTIRATE TRANSPONDER CARD FEATURES AND SPECIFICATIONS

Compact Design

The transponder card's compact design offers the following benefits:

- Single-width card-slot design for high-density, 10-Gbps solutions
- Up to 12 transponder cards per shelf assembly (120 Gbps), and 48 cards per bay (480 Gbps)

Flexible Protection Options

The transponder card includes the following features:

- Transparent support for UPSR/SNCP, BLSR/MSP, and 1+1 APS/MSP
- Client Y protection
- Unprotected (0+1)

Table 2. Regulatory Compliance¹

Countries Supported	
SONET/ANSI System	SDH/ETSI System
<ul style="list-style-type: none"> • Canada • United States • Mexico • Korea • Japan • European Union 	<ul style="list-style-type: none"> • European Union • Australia • New Zealand • Singapore • China • Mexico • Hong Kong • Korea
EMC (Class A)	
<ul style="list-style-type: none"> • ICES-003 Issue 3, 1997 • GR-1089-CORE, Level 3 • 47CFR15 	<ul style="list-style-type: none"> • EN 300 386-TC • CISPR22, CISPR24 • EN55022, EN55024
Safety	
<ul style="list-style-type: none"> • CAN/CSA-C22.2 No.950-95, Third Edition • GR-1089-CORE 	<ul style="list-style-type: none"> • UL 60950 • IEC 60950/EN60950, Third Edition
Laser	
<ul style="list-style-type: none"> • UL 60950 • IEC60950/EN60950 • IEC 60825-2 (2000) 	<ul style="list-style-type: none"> • CDRH (Accession letter and report) • IEC 60825-1 Am.2 (2001)
Environmental	
<ul style="list-style-type: none"> • GR-63-CORE, Level 3 • ETS 300-019-2-1 (Storage, Class 1.1) 	<ul style="list-style-type: none"> • ETS 300-019-2-2 (Transportation, Class 2.3) • ETS 300-019-2-3 (Operational, Class 3.1E)
Optical	
<ul style="list-style-type: none"> • GR-253-CORE • G.691 	<ul style="list-style-type: none"> • G.709 • G.975

Quality

- TR-NWT-000332, Issue 4, Method 1 calculation for 20-year mean time between failure (MTBF)

Miscellaneous

- | | |
|--|---|
| • AT&T Network Equipment Development Standards (NEDS) Generic Requirements, AT&T 802-900-260, Issue 3, December 1999 | • Verizon SIT.NEBS.NPI.2002.010, October 2002 |
| • SBC TP76200MP, May 2003 | • Worldcom ESD requirement |

1. All compliance documentation may not be completed at the time of product release. Please check with your Cisco sales representative for countries outside of Canada, the United States, and the European Union.

Tables 3 and 4 list the system requirements and the specifications for the transponder card.

Table 3. System Requirements

Component	Cisco ONS 15454 SONET/ANSI	Cisco ONS 15454 SDH/ETSI
Processor	TCC2 or TCC2P	TCC2 or TCC2P
Cross-connect	All (not required)	All (not required)
Shelf assembly	15454-SA-ANSI or 15454-SA-HD shelf assembly with FTA3 version fan-tray assembly	15454-SA-ETSI shelf assembly with SDH 48V fan-tray assembly
System software	Release 4.6.0 or later	Release 4.6.0 or later
Slot compatibility	1 to 6, 12 to 17	1 to 6, 12 to 17

Table 4. Specifications

Specification	SR/IO 1310 nm
Client Interface	
Specification	
Telcordia GR-253-Core	SR-1
ITU G.691	I-64.1
IEEE 802.3ae	10GE LAN PHY BASE-LR 10GE WAN PHY BASE-LW
Automatic laser shutdown and restart	ITU-T G.664
System reach (SR _{0db})	4 dB for OC-192/STM-64 signals
Unamplified targeted fiber distance, SMF28 ³ (FD _{smf28})	2 km for OC-192/STM-64 signal and 10 km for 10GE signals
Nominal wavelength (λ_{Tnom})	1310 nm
Spectral range (λ_{Tmin} to λ_{Tmax})	1290 to 1330 nm
Spectral width at 20 dB ($\Delta\lambda_{20}$)	1 nm
Optical Transmitter	
Type	Distributed feedback, direct modulation (DFB/DM) ⁴
Output power (P _{Tmin} to P _{Tmax})	-6 to -1 dBm
Minimum required optical return loss	24 dB
Minimum extinction ratio (r _{eminx})	6 dB
Laser safety class	1

Specification	SR/IO 1310 nm
Optical Receiver	
Type	PIN
Sensitivity at BER (P_{Rmin} to P_{Rmax})	-11 to -1 dBm for OC-192/STM-64 signals -14.4 dBm for 10GE signals
Chromatic dispersion tolerance (D_{SRmax})	6.6 ps/nm for OC-192/STM-64 signals
Power penalty (P_o)	1 dB
Minimum BER (BER_{min})	10E-12
Maximum reflectance between Tx (S) and Rx (R)	-27 dB
Maximum receiver reflectance	-14 dB
Optical signal-to-noise ratio (OSNR) (0.5-nm bandwidth at 10E-12 BER)	30 dB
Input wavelength bandwidth ($\lambda_{c,rx}$)	1290 to 1330 nm ⁵
Connector type (Tx/Rx)	LC, duplex, shuttered

3. Fiber distance of <FDSmf28>km in SMF28 of equivalent <SR0lb>dB optical link budget. Assumes D1550 = 17ps/nm/km, D1310 = 3.3ps/nm/km; fiber+splice+connector loss at 1550 nm = 0.275 dB/km and 1310 nm = 0.55 dB/km; including <Po>dB dispersion penalty at <DLRlong-reachmax>ps.

4 DFB/DM is typical but other technologies may be substituted if specifications are met.

5. Acceptable input wavelength range is 1290 to 1605 nm, but receiver sensitivity is guaranteed only for the indicated range.

Specification	
DWDM Line Interface	
Specification	
Telcordia GR-253-Core	LR-2
ITU G.691	L-64.2c
Automatic laser shutdown and restart	ITU-T G.664
Nominal wavelength (λ_{Tnom})	2-channel tunable (Table 5)
Spectral range (λ_{Tmin} to λ_{Tmax})	1530 to 1565 nm
Peak Wavelength Stability	+/-0.025 nm
Optical Transmitter	
Type	Continuous wave with Lithium niobate external modulator
Output power (P_{Tmin} to P_{Tmax})	3 dBm to +/-0.5 dB
Minimum required optical return loss	24 dB
Minimum extinction ratio (r_{eminx})	10 dB
Laser safety class	1
Optical Receiver	
Type	Avalanche photo diode (APD)
Sensitivity, FEC off (P_{Rmin} to P_{Rmax})	
OSNR < 23 dB	-21 to -8 dBm
OSNR < 23 dB at +/-1000 ps/nm	-19 to -9 dBm
Sensitivity, FEC on (P_{Rmin} to P_{Rmax})	
OSNR < 23 dB	-24 to -8 dBm
OSNR < 23 dB at +/-1000 ps/nm	-22 to -8 dBm
Note: OSNR defined at 0.5-nm bandwidth	

Chromatic dispersion tolerance (D_{LRmax})	+/-1000 ps/nm
Minimum BER (BER_{min})	
FEC off	10E-12
FEC on	10E-15
Reflectance between Tx and Rx (maximum)	-27 dB
Receiver reflectance (maximum)	-14 dB
Input wavelength bandwidth ($\lambda_{c,rx}$)	1530 to 1565 nm ⁵
Connector type (Tx/Rx)	LC, duplex, shuttered

Specification

Management

Card LEDs	
Failure (FAIL)	Red
Active/standby (ACT/STBY)	Green/yellow
Signal fail (SF)	Yellow
Client Port LEDs	
Active input signal	Green
DWDM Port LEDs	
Active input signal	Green
Output wavelength	Green

Power

Card power draw (including SFPs)	
Typical	45W
Maximum	50W

Operating Environment

Temperature	23 to 131°F (-5 to 55°C)
Humidity	5 to 95 percent noncondensing

Storage Environment

Temperature	-40 to 185°F (-40 to 85°C)
Humidity	5 to 95 percent noncondensing

Table 5. Supported Wavelengths on Transponder Cards⁶

Card (xx.x)	λ (nm)	Card (xx.x)	λ (nm)	Card (xx.x)	λ (nm)	Card (xx.x)	λ (nm)
30.3	1530.33 1531.12	38.1	1538.19 1538.98	46.1	1546.12 1546.92	54.1	1554.13 1554.94
31.9	1531.90 1532.68	39.7	1539.77 1540.56	47.7	1547.72 1548.51	55.7	1555.75 1556.55
34.2	1534.25 1535.04	42.1	1542.14 1542.94	50.1	1550.12 1550.92	58.1	1558.17 1558.98
35.8	1535.82 1536.61	43.7	1543.73 1544.53	51.7	1551.72 1552.52	59.7	1559.79 1560.61

6. Lead times on wavelength-based optical modules vary substantially. For assistance with wavelength selection, please refer to Cisco price list or lead-time tool, available on Cisco.com at: <http://www.cisco.com/en/US/ordering/index.shtml>

Table 6 lists ordering information for the transponder card.

Table 6. Ordering Information⁷

Part Number	Description
15454-10T-L1-xx.x	10-Gbps transponder optics card; short-reach client interface with LC connectors; long-reach, two-wavelength-tunable, 100-GHz ITU-compliant DWDM line optics with LC connectors, SONET platform
15454E-10T-xx.x	10-Gbps transponder optics card; intraoffice client interface with LC connectors; long-haul, two-wavelength-tunable, 100-GHz ITU-compliant DWDM line optics with LC connectors, SDH platform
15216-CS-SM-Y=	Y-cable splitter/combiner module, single-mode, single-width module, LC connectors, installs in Cisco FlexLayer shelf assembly (15216-FL-SA)
15216-FL-SA=	Shelf assembly, 4 module slots, 1-rack unit high, 19- or 23-inch rack mounting, Cisco FlexLayer platform

7. The letter "E" in the part number (for example, 15454E-) indicates SDH/ETSI system compatibility.

**Corporate Headquarters**

Cisco Systems, Inc.
170 West Tasman Drive
San Jose, CA 95134-1706
USA
www.cisco.com
Tel: 408 526-4000
800 553-NETS (6387)
Fax: 408 526-4100

European Headquarters

Cisco Systems International BV
Haarlerbergpark
Haarlerbergweg 13-19
1101 CH Amsterdam
The Netherlands
www-europe.cisco.com
Tel: 31 0 20 357 1000
Fax: 31 0 20 357 1100

Americas Headquarters

Cisco Systems, Inc.
170 West Tasman Drive
San Jose, CA 95134-1706
USA
www.cisco.com
Tel: 408 526-7660
Fax: 408 527-0883

Asia Pacific Headquarters

Cisco Systems, Inc.
168 Robinson Road
#28-01 Capital Tower
Singapore 068912
www.cisco.com
Tel: +65 6317 7777
Fax: +65 6317 7799

Cisco Systems has more than 200 offices in the following countries and regions. Addresses, phone numbers, and fax numbers are listed on **the Cisco Website at www.cisco.com/go/offices.**

Argentina • Australia • Austria • Belgium • Brazil • Bulgaria • Canada • Chile • China PRC • Colombia • Costa Rica
Croatia • Cyprus • Czech Republic • Denmark • Dubai, UAE • Finland • France • Germany • Greece • Hong Kong SAR
Hungary • India • Indonesia • Ireland • Israel • Italy • Japan • Korea • Luxembourg • Malaysia • Mexico
The Netherlands • New Zealand • Norway • Peru • Philippines • Poland • Portugal • Puerto Rico • Romania • Russia
Saudi Arabia • Scotland • Singapore • Slovakia • Slovenia • South Africa • Spain • Sweden • Switzerland • Taiwan
Thailand • Turkey • Ukraine • United Kingdom • United States • Venezuela • Vietnam • Zimbabwe

Copyright © 2006 Cisco Systems, Inc. All rights reserved. Cisco, Cisco Systems, and the Cisco Systems logo are registered trademarks or trademarks of Cisco Systems, Inc. and/or its affiliates in the United States and certain other countries.

All other trademarks mentioned in this document or Website are the property of their respective owners. The use of the word partner does not imply a partnership relationship between Cisco and any other company. (0601R) Pa/LW11534 06/06