



How To Select A Power Supply For Cisco Catalyst 4500 E-Series Switches

Getting Started

Questions to ask when selecting a power supply.

Is Power Over Ethernet (Poe) Required?

If PoE is not required, select the 1000W supply for the Cisco® Catalyst® 4503, 4506, and 4507R Switch chassis. Select the 1400W supply for Cisco Catalyst 4510R Switch chassis

- PoE supplies: 1300WACV, 2800WACV, 4200WACV, 1400WDC-P

How Many and What Type of Powered Devices Do You Require?

Maximum class 2/3 powered devices are supported.

Table 1. Maximum Class 2/3 Powered Devices Supported

	133W	2800W	4200W	1400WDC-P
4503*	101/45	178/80	470/213	All ports
4506*	100/45	178/80	469/213	All ports
4507R*	77/35	178/80	419/190	All ports
4510R*	N/A	178/80	419/190	All ports

*All configurations include a Cisco Catalyst 4000/4500 Supervisor Engine V with all line-card slots filled with 48-port PoE cards.

Figure 1. 4200W AC Power Supply



1000WAC: Data-only AC power supply designed for Cisco Catalyst 4503, 4506, and 4507R chassis

1300WACV: Data and limited PoE up to 46 class 3 devices; designed for small IP telephony and wireless deployments

1400WAC: Data-only AC supply designed for Cisco Catalyst 4510R chassis

2800WACV: Data and PoE up to 80 class 3 devices; designed for medium-sized PoE deployments

1400WDC-P: Data and large-scale PoE or DC PoE deployments; designed to be used with -48VDC power sources such as the power shelf or an AC-powered DC UPS

1400WDC: Data-only DC supply; designed for service providers with low-current circuits

4200WACV: Data and large-scale PoE deployments; designed for large PoE deployments

Quick Power Calculations

Calculating the maximum power required is simple. Your total system power requirement comes from two sources: data and PoE plus some efficiency loss. The following chart gives you baseline power requirement numbers for data power components on the Cisco Catalyst 4500E.

Table 2. Max Data Power Required

Chassis	Data power (Watts)	Heat in closet (BTU/hr)
4503	40	182
4506	60	273
4507R	90	409
4510R	120	546
4503-E	60	182
4506-E	120	273
4507R-E	135	409
4510R-E	200	546
Supervisor		
Sup II Plus	109	500
Sup II Plus TS	362	705

Sup IV	144	660	
Sup V	150	683	
Sup V-10GE	150	683	
Sup 6-E	260	938	
Line Cards			
10/100	65	296	
10/100 PoE	65	296	
10/100/1000	60	273	
10/100/1000 PoE	60	273	
48 Port Pluggable	84	387	
10/100 Fibre	120	546	
E-Series 10/100/1000 PoE	90	307	
E-Series 10GbE	50	170	
PoE Power Supply	Data Watts	PoE Watts	Heat Output (BTU/Hr)
1300WACV*	1000	800	1568
2800WACV	1400	1400	2387
4200WACV*	1400	3700	3580
2500W Shelf	N/A	2500	

*Maximum power supply output is equal to 1300W and 4200W, respectively.

The Formulas

Data Power Required = Sum Chassis Parts

PoE Power Required = Sum PoE device Watts / 89% efficiency

Required (Data Power Required + PoE Power Required) < Power Supply Max Select the power supply that has the required amount of PoE Watts

Example

Cisco Catalyst 4503 with a Supervisor Engine IV and 2x 48 port cards requiring all class 3 devices.



How To Select A Power Supply For Cisco Catalyst 4500e Series Switches

Cisco Catalyst 4503 + Supervisor Engine IV + 2x 10/100/1000 PoE = 304W Data Power (96 x class 3 PDs) / 89% = 1661W PoE Power

Total Power required = 1661W + 304W = 1965W

Order the 4200WAC Power Supply.

PoE device classifications:

Table 3. PoE Device Classifications

PoE Class	Watts
0/3	15.4*
1	4*
2	7*

*Power required at the port divide by 89% for power supply output Watts required.

Multi-Input Supplies Explained

Dual-Input 4200wac

The 4200W power supply is designed to accept either a 100V or a 200VAC circuit. Customers planning large-scale PoE deployments can use the inputs in the 200V mode. Customers planning for the future can deploy the 4200W supply with as little as one 100V circuit.

Table 4. Power Input Mapping

Mode	Input 1	Input 2	PoE Watts	Data Watts	Max Watts
1	100V	OFF	922	660	1050
2	100V	100V	1850	1400	2100
3	200V	OFF	1850	1400	2100
4	200V	200V	3700	1400	4200

1400WDC-P Power Input Options

The 1400WDC-P power supply has two operating modes. The default data-only mode and the inline power mode. When inline power is selected, the supply can provide up to 8600W of power to the chassis (data and

PoE). This is enough power to support a fully loaded Cisco Catalyst 4510 with all class 3 devices. This power can come from a variety of sources, including the AC power shelf or an AC-powered DC UPS.

An AC-powered DC UPS is powered by standard commercial power and outputs -48VDC to the 1400WDC-P supply. When compared with a standard AC UPS this solution is more efficient, produces less heat, takes up less space, and provides longer run times than a standard AC UPS. The AC-powered DC UPS requires only a single AC/DC conversion compared to three in an AC UPS.

Figure 2. UPS Design

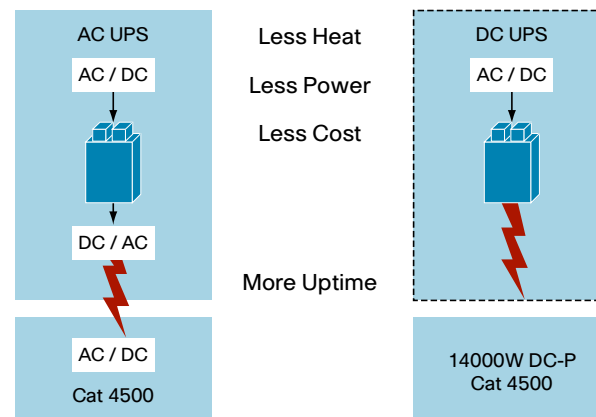

For More Information

http://www.cisco.com/en/US/products/hw/switches/ps4324/products_data_sheet09186a00801f3dd9.html