



# Antenna Product Portfolio for Cisco Aironet 1250 Series Access Points

Cisco® Aironet® 1250 Series Access Points require the use of external antennas to make them fully functioning units. Although most existing Cisco antennas can be used, Cisco has developed antennas specifically designed for use with 802.11n access points to optimize performance. This document explains antenna options for the Cisco Aironet 1250 Series Access Points.

## Flexible Options

Cisco offers a variety of antennas that provide different mounting options and coverage patterns. Customers can select an antenna that will increase the overall efficiency and data rates of their wireless network, while accommodating specific deployment conditions, including physical layout, distance, and aesthetics. To optimize the overall performance of a Cisco wireless LAN, it is important to understand how to maximize radio coverage with the appropriate antenna selection and placement. Table 1 illustrates the three antennas available for use with the 1250 Series Access Points.

**Table 1. Antennas for 1250 Series Access Points**

Antenna Type	Description	Ideal Deployment
<b>Dipole</b>	360 degree coverage pattern. Circular pattern covers large areas	Carpeted space environments, classrooms, hallways, conference rooms.
<b>Indoor/Outdoor Omni Directional</b>	360 degree coverage pattern. Circular pattern to cover wide areas	Open office areas, hallways, conference rooms, outside areas
<b>Directional</b>	Focused signal to direct energy in certain directions	Hallways, outside areas, on walls pointing inward to direct signals.

## Omnidirectional Antennas



An omnidirectional antenna is designed to provide a 360-degree radiation pattern. This type of antenna is used when coverage in all directions from the antenna is required. Cisco provides different types of omnidirectional antennas for use in a variety of environments, such as retail, manufacturing, or offices. Cisco provides both dipole antennas and indoor/outdoor omnidirectional antennas.

### Dipole Antennas

Dipole antennas are mounted directly to the Cisco Aironet 1250 Series Access Point and provide a large, circular coverage pattern. The antennas are available in three different colors (white, black and gray) so that they blend better into the area in which they will be placed. The white and black dipole antennas can be bent in different angles to modify the coverage as needed. The gray dipole does not offer this option and is shorter than its counterparts. If a reduced-sized dipole antenna is needed (for example, in an area where dipoles projecting into the space are undesirable), the gray dipole should be considered.

Other applications for dipoles include large, open areas like conference rooms or lecture halls. Areas requiring shared coverage—in which the access point is placed in the middle of the room or in a hallway, such as in a hotel or medical facility—are also a good use for the small form-factor dipole. Because of the circular pattern of coverage provided by dipole antennas, rooms located directly off the hallway may receive coverage as well. Table 2 lists the part numbers for 2.4-GHz and 5-GHz dipole antennas.

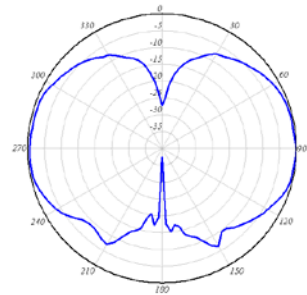
**Table 2. Dipole Antennas for Cisco Aironet 1250 Series Access Points**

	2.4-GHz Dipole Antenna Part Numbers	Quantity Required	Color	Gain
	AIR-ANT4941	3	Black	2.2 dBi
	AIR-ANT2422DW-R	3	White	2.2 dBi
	AIR-ANT2422DG-R	3	Gray	2.2 dBi
<b>Typical Antenna Pattern 1</b> 				
	5-GHz Dipole Antenna Part Numbers	Quantity Required	Color	Gain
	AIR-ANT5135D-R	3	Black	3.5 dBi
	AIR-ANT5135DW-R	3	White	3.5 dBi
	AIR-ANT5135DG-R	3	Gray	3.5 dBi



### Indoor/Outdoor Omnidirectional Antennas

Omnidirectional antennas are mounted to Cisco Aironet 1250 Series Access Points via short, attached cables. The antennas can be mounted to a ceiling and provide a large, circular coverage area. These antennas can be used both inside and outdoors (see Table 3 for specific details for usage) and are typically mounted on a ceiling or mast-pole. Examples of places in which omnidirectional antennas are useful include warehouses, manufacturing floors, and other large areas, as well as outdoor seating areas, such as cafés or central gathering places for students. Omnidirectional antennas can also be used to provide good coverage in a retail environment, both indoors and outside, as well as in areas where trucks or police cars dock and need to upload data.

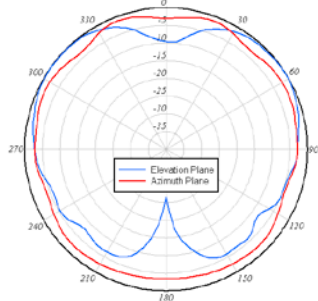

# Antenna Product Portfolio for Cisco Aironet 1250 Series Access Points

**Table 3. Indoor/Outdoor Omnidirectional Antennas for Cisco Aironet 1250 Series Access Points**

	2.4-GHz Omnidirectional Antenna Part Numbers		Quantity Required	Description	Gain
	AIR-ANT1728		3	Ceiling-mount: indoor/outdoor	5.2 dBi
	AIR-ANT2506		3	Mast-mount: indoor/outdoor	5.2 dBi
	AIR-ANT2430V-R		1	Ceiling-mount: indoor	3 dBi
<b>Typical Antenna Pattern 2</b> 					
	5-GHz Omnidirectional Antenna Part Numbers		Quantity Required	Description	Gain
	AIR-ANT5140V-R		1	Ceiling-mount: indoor	4 dBi
	AIR-ANT5160V-R		3	Ceiling-mount: indoor/outdoor	6 dBi

## Directional Antennas

Directional antennas redirect the signal they receive from the access point. Redirecting the signal has the effect of providing more energy in one direction and less energy in all other directions.

## Patch and Yagi Antennas

These antennas are typically mounted to a wall or a mast and provide coverage in a limited-angle pattern. Application cases for a directional antenna include RF coverage down a hallway in a hospital or office corridor. In a warehouse or manufacturing facility, which typically have high steel-shelving units, aiming a directional antenna down open areas provides coverage for people moving among the shelves with their wireless devices. The mining industry also benefits from the use of directional antennas when wireless is used in the shafts. Table 4 shows the directional antennas available for use with the Cisco Aironet 1250 Series Access Points.

**Table 4. Directional Antennas for Cisco Aironet 1250 Series Access Points**

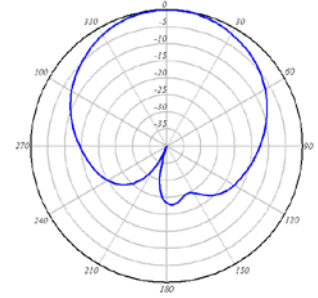
	2.4-GHz Directional Antenna Part Numbers		Quantity Required	Description	Gain
	AIR-ANT2460P-R		3	Patch antenna: indoor/outdoor, wall mount	6 dBi
	AIR-ANT2485P-R		3	Patch antenna: indoor/outdoor, wall mount	8.5 dBi
	AIR-ANT2410Y-R		3	Yagi antenna: indoor/outdoor, mast mount	10 dBi
<b>Typical Antenna Pattern 3</b> 					

## Why Cisco?

Cisco is committed to providing the best access points, client adapters, and bridges in the industry and to providing a complete solution for any wireless LAN deployment. Cisco also has the widest range of antennas, cable, and accessories available from any wireless manufacturer. For more information on Cisco Aironet antennas, visit:

<http://www.in.cisco.com/ewtg/wnbu/products/antennas.shtml>