



# Cisco Unified CallManager Release 4.1(2) with Avaya Intuity AUDIX with Avaya Definity G3 MV1.1 PBX with 6608 T1 Q.SIG as MGCP Gateway

10/31/2007

## Table of Contents

<a href="#">Introduction</a>	1
<a href="#">Network Topology</a>	2
<a href="#">System Components</a>	2
<a href="#">Hardware Requirements</a>	2
<a href="#">Software Requirements</a>	2
<a href="#">Features</a>	3
<a href="#">Features Supported</a>	3
<a href="#">Configuration</a>	3
<a href="#">Configuring the Avaya Definity G3 PBX</a>	3
<a href="#">Configuring the Avaya Intuity AUDIX</a>	19
<a href="#">Note: CallManager users' mailboxes are configured with field Switch Number set to 2</a>	22
<a href="#">Configuring the Cisco Unified CallManager</a>	22
<a href="#">Appendix A</a>	30
<a href="#">CallManager Software Release</a>	30
<a href="#">Avaya Definity G3 Software Releases</a>	30
<a href="#">Intuity AUDIX Software Releases</a>	31
<a href="#">Cisco Catalyst 6500 Switch Configuration</a>	33
<a href="#">Acronyms</a>	39

## Introduction

- This is a lab report performed to ascertain interoperability of Cisco Unified CallManager Release 4.1(2) when used as a PINX in a QSIG private network comprised of Avaya Definity G3 MV1.1 and a Centralized Intuity AUDIX voicemail server using C-LAN integration.
- The network topology diagram (Figure 1) shows the test setup for end-to-end interoperability with the Cisco Unified CallManager connected to the PBX's via Catalyst 6608 T1/E1 blade ports used as MGCP gateways configured as ISO QSIG trunks, and an Intuity AUDIX used as a Centralized voicemail system using C-LAN integration to the "host" Avaya Definity G3
- This Application Note uses the Cisco Catalyst 6608 T1/E1 voice gateway; however other Cisco voice gateways are also an option to use since Cisco Unified CallManager QSIG implementation does not depend on the physical interface.

## Network Topology

Figure 1. Network Topology

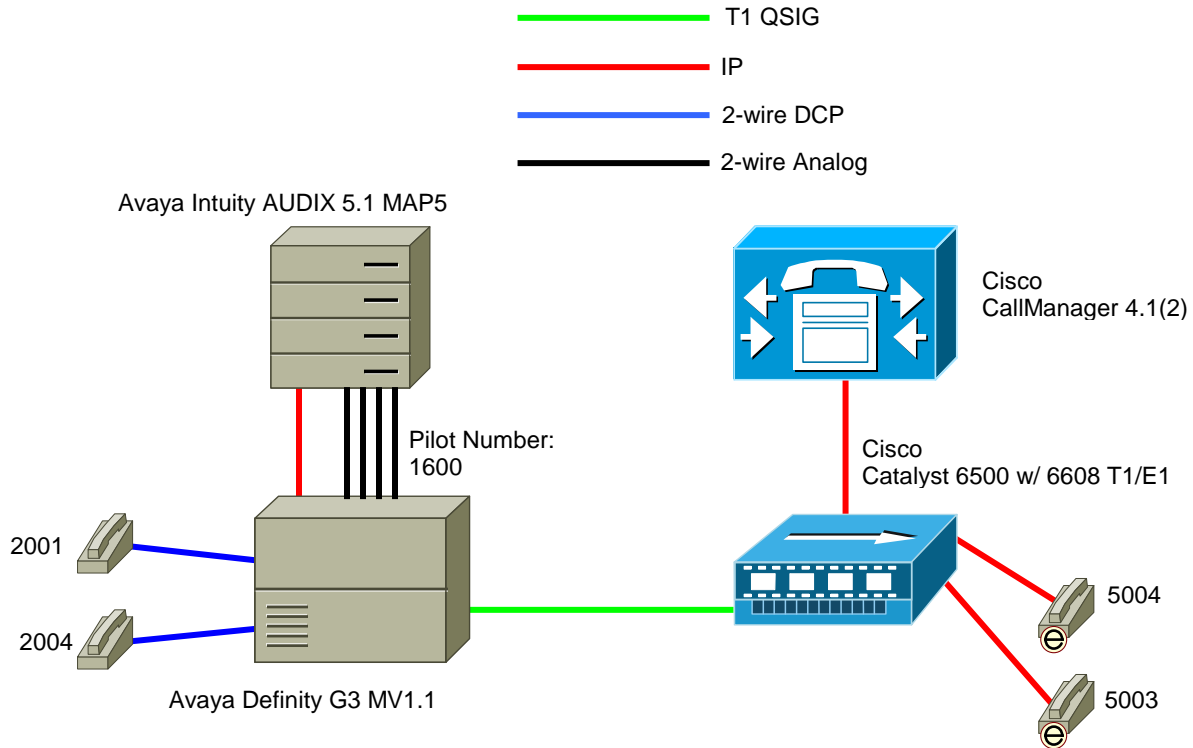

## System Components

### Hardware Requirements

The following hardware is required:

- Cisco Catalyst 6500 switch with 6608 T1/E1 blades
- Cisco MCS server
- Avaya TN464F DS1 circuit pack
- Avaya TN799DP C-LAN card
- Avaya Intuity MAP server

### Software Requirements

The following software is required:



- Cisco Unified CallManager Release 4.1(2)
- Cisco 6500 CatOs 7.6(8)
- Avaya Definity G3 MV1.1
- Avaya Intuity AUDIX R5.1 w/OVERLAN integration (LANSet SWIN package)

## Features

This section lists new and changed features and features that are not supported.

### Features Supported

- Station forward to personal greeting (busy/ring no answer/all calls)
- Reply to messages left in telephone answering mode
- Direct Call
- Message Waiting Indication

## Configuration

The configuration examples shown in this document is an example only; its settings are typical only. In addition, prior to configuring the “central” Definity G3 and CallManager, the following should be installed and tested for proper functionality:

- **Intuity AUDIX** - Test for proper functionality of the Intuity AUDIX for “Central” Definity G3 users
- **Unique Extension Numbering Plans** – Extension numbers on the Definity G3 and Cisco Unified CallManager must be unique and of the same length

### Configuring the Avaya Definity G3 PBX

1. Display customer-optional features configuration forms to insure required features are enabled on PBX
2. Configure the DS1 circuit pack(s)
3. Configure the Signaling Group(s)
4. Configure the Trunk Group(s)
5. Configure ISDN Numbering plan
6. Configure the Uniform Dialing Plan
7. Configure Route Pattern(s)
8. Configure Processor Channels for AUDIX Message Waiting updates to CallManager stations
9. Configure ISDN Message Waiting Prefixes
10. Configure Intuity AUDIX Hunt Group and analog ports
11. Configure feature-related System Parameters for Centralized AUDIX operation

“Central” Avaya G3 Configuration Menus for Q.SIG trunk connectivity to CallManager

**Figure 2.** Customer-option system parameter form - Page 1



```
display system-parameters customer-options Page 1 of 9
OPTIONAL FEATURES
G3 Version: U11 Maximum Ports: 274 USED 166
Location: 1 Maximum XMOBILE Stations: 10 0
Platform: 2
IP PORT CAPACITIES
Maximum Administered IP Trunks: 1 1
Maximum Concurrently Registered IP Stations: 16 0
Maximum Administered Remote Office Trunks: 0 0
Maximum Concurrently Registered Remote Office Stations: 0 0
Maximum Concurrently Registered IP eCons: 1 0
Maximum Number of DS1 Boards with Echo Cancellation: 30 0
Maximum TN2501 UAL Boards: 1 0
(NOTE: You must logoff & login to effect the permission changes.)
```



Figure 3. Customer-option system parameter form - Page 2

```
display system-parameters customer-options Page 2 of 9
OPTIONAL FEATURES
Abbreviated Dialing Enhanced List? y Audible Message Waiting? y
Access Security Gateway (ASG)? n Authorization Codes? y
Analog Trunk Incoming Call ID? y CAS Branch? n
A/D Grp/Sys List Dialing Start at 01? y CAS Main? n
Answer Supervision by Call Classifier? y Change COR by FAC? y
ARS? y Computer Telephony Adjunct Links? n
ARS/AAR Partitioning? y Co-Res DEFINITY LAN Gateway? n
ARS/AAR Dialing without FAC? n Cvg Of Calls Redirected Off-net? y
ASAI Link Core Capabilities? n DCS (Basic)? y
ASAI Link Plus Capabilities? n DCS Call Coverage? y
DCS with Rerouting? y
Async. Transfer Mode (ATM) Trunking? n
ATMS? y Digital Loss Plan Modification? y
Attendant Vectoring? y DS1 MSP? n
DS1 Echo Cancellation? y
(NOTE: You must logoff & login to effect the permission changes.)
```

Note: Make sure features ARS and ARS/AAR Partitioning are set to y

Figure 4. Customer-option system parameter form - Page 3

```
display system-parameters customer-options Page 3 of 9
OPTIONAL FEATURES
Emergency Access to Attendant? y ISDN Feature Plus? y
Enable 'dadmin' Login? y ISDN Network Call Redirection? n
Enhanced Conferencing? y ISDN-BRI Trunks? y
Enhanced EC500? y ISDN-PRI? y
Extended Cvg/Fwd Admin? y Local Spare Processor? n
External Device Alarm Admin? y Malicious Call Trace? y
Five Port Networks Max Per MCC? n Media Encryption Over IP? n
Flexible Billing? y Mode Code for Centralized Voice Mail? y
Forced Entry of Account Codes? y
Global Call Classification? y Multifrequency Signaling? y
Hospitality (Basic)? y Multimedia Appl. Server Interface (MASI)? n
Hospitality (G3V3 Enhancements)? y Multimedia Call Handling (Basic)? y
IP Trunks? y Multimedia Call Handling (Enhanced)? y
Multiple Locations? y
IP Attendant Consoles? y Personal Station Access (PSA)? y
IP Stations? y Posted Messages? n
(NOTE: You must logoff & login to effect the permission changes.)
```



Note: Make sure feature **ISDN-PRI** is set to **y**

Figure 5. Customer-option system parameter form - Page 4

```
display system-parameters customer-options Page 4 of 9
OPTIONAL FEATURES
Port Network Support? y
Processor and System MSP? n
Private Networking? y
Remote Office? y
Restrict Call Forward Off Net? y
Secondary Data Module? y
Station and Trunk MSP? n
Station as Virtual Extension? y
Survivable Remote Processor? n
System Management Data Transfer? y
Tenant Partitioning? n
Terminal Trans. Init. (TTI)? y
Time of Day Routing? y
Uniform Dialing Plan? y
Usage Allocation Enhancements? y
TN2501 UAL Maximum Capacity? y
Wideband Switching? y
Wireless? n
(NOTE: You must logoff & login to effect the permission changes.)
```

Note: Make sure features **Private Networking**, **Uniform Dialing Plan** are set to **y**



Figure 6. Customer-option system parameter form - Page 7

```
display system-parameters customer-options Page 7 of 9
      QSIG OPTIONAL FEATURES
          Basic Call Setup? y
          Basic Supplementary Services? y
          Centralized Attendant? y
          Interworking with DCS? y
          Supplementary Services with Rerouting? y
          Transfer into QSIG Voice Mail? y
          Value-Added (VALU)? y

(NOTE: You must logoff & login to effect the permission changes.)
```

Note: Make sure features **Basic Call Setup** and **Basic Supplementary Services** are set to **y**

Figure 7. DS1 circuit pack configuration

```
display ds1 1a13 Page 1 of 2
      DS1 CIRCUIT PACK
          Location: 01A13 Name: QSIG to 3745
          Bit Rate: 1.544 Line Coding: b8zs
          Line Compensation: 5 Framing Mode: esf
          Signaling Mode: isdn-pri
          Connect: pbx Interface: peer-master
          TN-C7 Long Timers? n Peer Protocol: Q-SIG
          Interworking Message: PROGRESS Side: a
          Interface Companding: mulaw CRC? n
          Idle Code: 11111111
          DCP/Analog Bearer Capability: 3.1kHz

          Slip Detection? n Near-end CSU Type: other
```



Note: The configuration above shows the DS1 circuit pack configured as a T1 trunk., although the DS1 circuit can be also configured as E1 trunk.

Figure 8. Signaling Group configuration

```
display signaling-group 13
SIGNALING GROUP
Group Number: 13          Group Type: isdn-pri
Associated Signaling? y   Max number of NCA TSC: 5
Primary D-Channel: 01A1324 Max number of CA TSC: 23
Trunk Group for Channel Selection: 13  Trunk Group for NCA TSC: 13
Supplementary Service Protocol: b      X-Mobility/Wireless Type: NONE
```

Figure 9. Trunk Group configuration – Page 1

```
display trunk-group 13                                     Page 1 of 10
TRUNK GROUP
Group Number: 13          Group Type: isdn          CDR Reports: y
Group Name: QSIG trunk to Jupiter      COR: 1          TN: 1          TAC: 613
Direction: two-way        Outgoing Display? y     Carrier Medium: PRI/BRI
Dial Access? y            Busy Threshold: 99      Night Service:
Queue Length: 0
Service Type: tie          Auth Code? n           TestCall ITC: rest
Far End Test Line No:
TestCall BCC: 4
TRUNK PARAMETERS
Codeset to Send Display: 0          Codeset to Send National IEs: 6
Max Message Size to Send: 260      Charge Advice: none
Supplementary Service Protocol: b    Digit Handling (in/out): enbloc/enbloc
Trunk Hunt: ascend                 QSIG Value-Added? y
Digital Loss Group: 13
Calling Number - Delete:          Insert:          Numbering Format: unk-unk
Bit Rate: 1200                    Synchronization: async Duplex: full
Disconnect Supervision - In? y Out? y
Answer Supervision Timeout: 0
```



Figure 10. Trunk Group configuration – Page 2

```

display trunk-group 13                                     Page 2 of 10
TRUNK FEATURES
  ACA Assignment? n                                     Measured: none      Wideband Support? n
                                                         Internal Alert? n   Maintenance Tests? y
                                                         Data Restriction? n NCA-TSC Trunk Member: 1
                                                         Send Name: y       Send Calling Number: y
  Used for DCS? n                                       Hop Dgt? y
  Suppress # Outpulsing? n                               Numbering Format: unknown
  Outgoing Channel ID Encoding: preferred              UUI IE Treatment: service-provider
                                                         Replace Restricted Numbers? y
                                                         Replace Unavailable Numbers? n
                                                         Send Called/Busy/Connected Number: y
  Send UUI IE? y
  Send UCID? y
  Send Codeset 6/7 LAI IE? y                            Ds1 Echo Cancellation? n
  Path Replacement with Retention? n
  Path Replacement Method: better-route
                                                         SBS? n Network (Japan) Needs Connect Before Disconnect? y

```

Figure 11. ISDN Numbering plan configuration

```

display isdn public-unknown-numbering                     Page 1 of 8
ISDN NUMBERING - PUBLIC/UNKNOWN FORMAT
Total
Ext Len Ext Code Trk Grp(s) CPN Prefix Total
CPN Ext Len Ext Code Trk Grp(s) CPN Prefix CPN Len
4 2 4 3 4 4 13 4 4 4 4 16 4

```



Note: Since the QSIG trunk group used for this testing is configured to use ISDN – Unknown Numbering, configuration form “ISDN Public-Unknown-Numbering” is used. If trunk group(s) are configured to use Private numbering, configuration form “ISDN Private-Numbering” needs to be used.

Figure 12. Dial Plan Configuration

```
display dialplan analysis Page 1 of 3
```

DIAL PLAN ANALYSIS TABLE								
Percent Full: 2								
Dialed String	Total Length	Call Type	Dialed String	Total Length	Call Type	Dialed String	Total Length	Call Type
0	1	attd						
16	4	ext						
20	4	ext						
22	4	dac						
3	4	ext						
4	4	ext						
5	4	ext						
6	3	dac						
7	5	ext						
8	1	fac						
9	1	fac						
*	3	fac						



Figure 13. Uniform Dial Plan Configuration

```
list uniform-dialplan
UNIFORM DIAL PLAN TABLE
Matching Pattern  Len  Del  Insert Digits  Net  Conv  Node Num
10                4    0    998            aar  n
2000              4    0    222            aar  n
2005              4    0    777            aar  n
2012              4    0    333            aar  n
31                4    0    310            aar  n
4                 4    0    222            aar  n
4003              4    0    666            aar  n
4006              4    0    510            aar  n
5                 4    0    555            aar  n
5050              4    0    777            aar  n
51                4    0    510            aar  n
52                4    0    520            aar  n
53                4    0    530            aar  n
54                4    0    999            aar  n
7                 4    0    777            aar  n
Command successfully completed
```

Figure 14. Call Routing Configuration (AAR)

```
display aar analysis 555 Page 1 of 2
AAR DIGIT ANALYSIS TABLE
Percent Full: 2
Dialed String      Total      Route      Call      Node      ANI
                   Min Max    Pattern   Type      Num      Reqd
555                 7  7      105      aar       n
611                 7  7       13      aar       n
777                 7  7       13      aar       n
888                 7  7       15      aar       n
998                 7  7       11      aar       n
999                 7  7       98      aar       n
n
n
n
n
n
n
n
n
```



Figure 15. Route Pattern Configuration

```

display route-pattern 105
Pattern Number: 105 Pattern Name: QSIG - 14 First

  Grp FRL NPA Pfx Hop Toll No.  Inserted          DCS/  IXC
  No   Mrk Lmt List Del  Digits          QSIG
  1: 13  0                3                Intw
  2:                                     n    user
  3:                                     n    user
  4:                                     n    user
  5:                                     n    user
  6:                                     n    user

  BCC VALUE  TSC CA-TSC  ITC BCIE Service/Feature BAND  No. Numbering LAR
  0 1 2 3 4 W      Request          Dgts Format
  1: y y y y y n  y  as-needed  bothept                none
  2: y y y y y n  n                rest                    none
  3: y y y y y n  n                rest                    none
  4: y y y y y n  n                rest                    none
  5: y y y y y n  n                rest                    none
  6: y y y y y n  n                rest                    none
  
```

Figure 16. Processor Channels Configuration

```

display communication-interface processor-channels
Page 1 of 16
PROCESSOR CHANNEL ASSIGNMENT
Proc  Gtwy  Interface  Destination  Session  Mach
Chan Enable Appl.  To  Mode Link/Chan  Node  Port  Local/Remote ID
 1:  y  audix  s  1  5002  audix  0  1  1  1
 2:  y  qsig-mwi  s  1  6002  audix  0  2  1  2
 3:  n
 4:  n
 5:  n
 6:  n
 7:  n
 8:  n
 9:  n
10:  n
11:  n
12:  n
13:  n
14:  n
15:  n
16:  n
  
```



Notes:

- Processor Channel 1 is assigned to AUDIX for exchanging call-related data and for message waiting updates to the “Central” PBX. Processor Channel 2 handles Q.SIG message waiting updates to the CallManager stations
- The **Proc. Chan**, **Session Local** and **Mach ID** settings should all be the same
- The **Mach ID** field is also used to match entries in the **ISDN mwi-prefixes** configuration form (Figure 17)
- The **Link** field should contain the link number assigned to the C-LAN card (data-module configuration form). That is usually set to 1 on PBX’s with single C-LAN circuit packs
- The **Node** field should contain the AUDIX node name as entered in the **node-names audix-msa** configuration form
- The **Chan** numbers should match the **TCP Port** number configured on the Intuity AUDIX **Switch Link Administration** form (Figure 25). On Definity PBX’s, Channel numbers (TCP Ports numbers) start with 5002 for AUDIX apps, and 6002 for qsig-mwi apps
- Leave the **Destination Port** field as 0

Figure 17. ISDN MWI Prefixes

```
display isdn mwi-prefixes
MESSAGE WAITING INDICATION SUBSCRIBER NUMBER PREFIXES
```

Machine ID	Inserted Digits	Routing Digits	AUDIX Mach ID	Machine ID	Inserted Digits	Routing Digits	AUDIX Mach ID
1:				11:			
2:		8555	1	12:			
3:				13:			
4:				14:			
5:				15:			
6:				16:			
7:				17:			
8:				18:			
9:				19:			
10:				20:			

Notes:



- Choose the **Machine ID** used previously on the **communication-interface processor channel** configuration form for qsig-mwi operation. In our example we used Machine ID 2; hence the entry in this screen is done on the second line of the form, which is associated with Machine ID 2
- In the **Routing Digits** field, enter the routing digits used to send the calls over the proper Route Pattern. In this example, we used 8555. The digit 8 in our lab's Definity G3 is the AAR feature access code; the 555 is the aar routing digits pattern used to route calls over to Route Pattern 105, which is the route pattern used to send calls to the Q.SIG trunk group connecting to CallManager. Route Pattern 105 is configured, as illustrated in Figure 10, to strip the leading 3 digits (aar routing digits 555, as the digit 8 is a feature access code and will therefore not be passed as part of the routing digits)
- In the **AUDIX Mach ID** field, enter the **AUDIX Number** as set in the Intuity **AUDIX Switch Link Administration** form (Figure 25)

Figure 18. Hunt Group Configuration for AUDIX - Page 1

```
display hunt-group 99                                     Page 1 of 10
HUNT GROUP
  Group Number: 99                                       ACD? n
  Group Name: AUDIX                                     Queue? n
  Group Extension: 1600                                  Vector? n
  Group Type: ucd-mia                                   Coverage Path:
  TN: 1                                                  Night Service Destination:
  COR: 16                                               MM Early Answer? n
  Security Code:
  ISDN Caller Display: grp-name
```

Note: in the **Group Type** field, enter **ucd-mia**

Figure 19. Hunt Group Configuration for AUDIX - Page 2



```
display hunt-group 99                                     Page 2 of 10
HUNT GROUP
Message Center: audix

Calling Party Number to INTUITY AUDIX? y
LWC Reception: none
```

Notes:

- In the **Message Center** field, enter **audix**.
- In the **Calling Party Number to INTUITY AUDIX?** field, enter **y**



Figure 20. Hunt Group Configuration for AUDIX - Page 3

```
display hunt-group 99 Page 3 of 10
HUNT GROUP
  Group Number: 99      Group Extension: 1600      Group Type: ucd-mia
  Member Range Allowed: 1 - 200      Administered Members (min/max): 1 /1
                                      Total Administered Members: 1
GROUP MEMBER ASSIGNMENTS
  Ext      Name (24 characters)      Ext      Name (24 characters)
  1 : 1601      Audix Port 01      14 :
  2 :
  3 :
  4 :
  5 :
  6 :
  7 :
  8 :
  9 :
  10 :
  11 :
  12 :
  13 :
  14 :
  15 :
  16 :
  17 :
  18 :
  19 :
  20 :
  21 :
  22 :
  23 :
  24 :
  25 :
  26 :

At End of Member List
```



Figure 21. Analog voice port configuration - Page 1

```
display station 1601                                     Page 1 of 3
STATION
Extension: 1601                                         Lock Messages? n      BCC: 0
Type: 2500                                              Security Code:        TN: 1
Port: 01A0301                                          Coverage Path 1:     COR: 15
Name: Audix Port 01                                   Coverage Path 2:     COS: 15
                                                         Hunt-to Station:     Tests? y

STATION OPTIONS
    Loss Group: 1                                       Message Waiting Indicator: none
Off Premises Station? n

Remote Office Phone? n
```

Figure 22. Analog voice port configuration - Page 2

```
display station 1601                                     Page 2 of 3
STATION
FEATURE OPTIONS
    LWC Reception: audix
    LWC Activation? n
LWC Log External Calls? n
    CDR Privacy? n
Redirect Notification? n
Per Button Ring Control? n
Bridged Call Alerting? n
    Switchhook Flash? y
Ignore Rotary Digits? n
    H.320 Conversion? n
    Service Link Mode: as-needed
    Multimedia Mode: basic
MWI Served User Type:
    Coverage Msg Retrieval? n
    Auto Answer: none
    Data Restriction? n
    Call Waiting Indication? n
    Att. Call Waiting Indication? n
    Distinctive Audible Alert? n
    Adjunct Supervision? y
    Per Station CPN - Send Calling Number?
    Audible Message Waiting? n
    Coverage After Forwarding? s
    Multimedia Early Answer? n
    Direct IP-IP Audio Connections? n
    IP Audio Hairpinning? n

Emergency Location Ext: 1601
```

Figure 23. Feature-related system parameter Configuration - Page 1



```
display system-parameters features Page 1 of 12
FEATURE-RELATED SYSTEM PARAMETERS
  Self Station Display Enabled? y
  Trunk-to-Trunk Transfer: all
Automatic Callback - No Answer Timeout Interval (rings): 3
  Call Park Timeout Interval (minutes): 10
  Off-Premises Tone Detect Timeout Interval (seconds): 20
  AAR/ARS Dial Tone Required? y
  Music/Tone on Hold: none
  Music (or Silence) on Transferred Trunk Calls? no
  DID/Tie/ISDN Intercept Treatment: attd

Internal Auto-Answer of AttD-Extended/Transferred Calls: transferred
  Automatic Circuit Assurance (ACA) Enabled? n

  Abbreviated Dial Programming by Assigned Lists? n
  Auto Abbreviated/Delayed Transition Interval (rings): 2
  Protocol for Caller ID Analog Terminals: Bellcore
Display Calling Number for Room to Room Caller ID Calls? y
```

Note: set field **Trunk-to-Trunk Transfer** to **all**.



Figure 24. Feature-related system parameter Configuration - Page 7

```
display system-parameters features Page 7 of 12
FEATURE-RELATED SYSTEM PARAMETERS

ISDN PARAMETERS

Send Non-ISDN Trunk Group Name as Connected Name? n
Display Connected Name/Number for ISDN DCS Calls? y
Send ISDN Trunk Group Name on Tandem Calls? n

                QSIG TSC Extension: 2099
MWI - Number of Digits Per Voice Mail Subscriber: 4
                Feature Plus Ext: 2098
                National CPN Prefix:
                International CPN Prefix:
                Pass Prefixed CPN to ASAI? n
Unknown Numbers Considered Internal for AUDIX? y Maximum Length: 5
USNI Calling Name for Outgoing Calls? y
Path Replacement with Measurements? y
                QSIG Path Replacement Extension: 2097
Path Replace While in Queue/Vectoring? y
```

Notes:

- Set field **Connected Name/Number for ISDN DCS Calls?** to **y**
- In the field **QSIG TSC Extension**, enter a valid available extension number
- Set field **MWI – Number of Digits Per Voice Mail Subscriber** to match the extension length being used in the customer’s private network (in our example, this is set to 4)
- Set field **Unknown Numbers Considered Internal for AUDIX?** to **y**

In the **Maximum Length** field, again enter the extension length used in the customer’s private network.

### Configuring the Avaya Intuity AUDIX

As mentioned at the beginning of this document, Intuity AUDIX should have already been installed and configured to proper integrate with the “Central” Definity PBX. Test calls should have been made to verify its operation. In order to provide proper QISG MWI signaling to the CallManager, additional configuration must be made in the Switch Link Administration form so as to add an additional “Switch”, which is the one used by CallManager station users’ mailboxes. In our example, this is Switch Number 2.



Figure 25. AUDIX Switch Link Administration form

```

Switch Link Administration

Switch Link Type : LAN                Country : UNITED STATES
Extension Length : 4                  Switch  : DEFINITY OVERLAN
Host Switch Number: 1
AUDIX Number     : 1

Switch Number  IP Address/Host Name  TCP Port  Switch Number  IP Address/Host Name  TCP Port
-----
1             172.20.7.252                 5002     2             172.20.7.252                 6002
  
```

Figure 26. Central PBX users' mailbox configuration

```

AUDIX Active Alarms: w Logins: 2
display subscriber 2001 Page 1 of 2
SUBSCRIBER

Name: test mbox 2 Locked? n
Extension: 2001 Password:
COS: class00 Miscellaneous 1:
Switch Number: 1 Miscellaneous 2:
Community ID: 1 Miscellaneous 3:
Secondary Ext: Miscellaneous 4:
Account Code: Covering Extension:
Broadcast Mailbox? n

Email Address:
  
```

Note: Central PBX mailboxes are configured with field **Switch Number** set to 1

Figure 27. CallManager users' mailbox configuration



```
AUDIX           Active           Alarms:  w           Logins: 2
display subscriber 5003           Page 1 of 2
SUBSCRIBER
Name: test mbox 11           Locked? n
Extension: 5003           Password:
COS: class00           Miscellaneous 1:
Switch Number: 2           Miscellaneous 2:
Community ID: 1           Miscellaneous 3:
Secondary Ext:           Miscellaneous 4:
Account Code:           Covering Extension:
Broadcast Mailbox? n
Email Address:
```



**Note:** CallManager users' mailboxes are configured with field **Switch Number** set to 2

### Configuring the Cisco Unified CallManager

6608 T1/E1 Voice Gateway Configuration

## Gateway Configuration

[Back to Find/List Gateways](#)  
[Dependency Records](#)

**Product :** Cisco Catalyst 6000 T1 VoIP Gateway  
**Gateway :** S0/DS1-0@SDA0001C9D93A9B  
**Device Protocol:** Digital Access PRI  
**Registration:** Registered with Cisco CallManager 172.20.236.2  
**IP Address:** [172.20.236.16](#)

Status: Ready

### Device Information

MAC Address*	<input type="text" value="0001C9D93A9B"/>
Description	<input type="text" value="Cat 6500 port 5/4"/>
Device Pool*	<input type="text" value="Default"/>
Call Classification*	<input type="text" value="OnNet"/>
Network Locale	<input type="text" value="United States"/>
Media Resource Group List	<input type="text" value="&lt; None &gt;"/>
Location	<input type="text" value="&lt; None &gt;"/>
AAR Group	<input type="text" value="&lt; None &gt;"/>
Load Information	<input type="text"/>

### Multilevel Precedence and Preemption (MLPP) Information



### Multilevel Precedence and Preemption (MLPP) Information

MLPP Domain (e.g., "0000FF")	<input type="text"/>
MLPP Indication	<input type="text" value="Off"/>
MLPP Preemption	<input type="text" value="Disabled"/>

### Interface Information

PRI Protocol Type*	<input type="text" value="PRI QSIG T1"/>
Protocol Side*	<input type="text" value="User"/>
Channel Selection Order*	<input type="text" value="Bottom Up"/>
Channel IE Type*	<input type="text" value="Use Number when 1B"/>
PCM Type*	<input type="text" value="μ-law"/>
Delay for first restart (1/8 sec ticks)	<input type="text" value="32"/>
Delay between restarts (1/8 sec ticks)	<input type="text" value="4"/>
<input checked="" type="checkbox"/> Inhibit restarts at PRI initialization	
<input type="checkbox"/> Enable status poll	



## Call Routing Information

### Inbound Calls

Significant Digits*	<input type="text" value="All"/>
Calling Search Space	<input type="text" value="&lt; None &gt;"/>
AAR Calling Search Space	<input type="text" value="&lt; None &gt;"/>
Prefix DN	<input type="text"/>

### Outbound Calls

Calling Line ID Presentation*	<input type="text" value="Allowed"/>
Calling Party Selection*	<input type="text" value="Originator"/>
Called party IE number type unknown*	<input type="text" value="Cisco CallManager"/>
Calling party IE number type unknown*	<input type="text" value="Cisco CallManager"/>
Called Numbering Plan*	<input type="text" value="Cisco CallManager"/>
Calling Numbering Plan*	<input type="text" value="Cisco CallManager"/>
Number of digits to strip*	<input type="text" value="0"/>
Caller ID DN	<input type="text"/>
SMDI Base Port*	<input type="text" value="0"/>



### PRI Protocol Type Specific Information

- Display IE Delivery
- Redirecting Number IE Delivery - Outbound
- Redirecting Number IE Delivery - Inbound
- Send Extra Leading Character In DisplayIE\*\*\*
- Setup non-ISDN Progress Indicator IE Enable\*\*\*\*
- MCDN Channel Number Extension Bit Set to Zero\*\*
- Send Calling Name In Facility IE
- Interface Identifier Present\*\*

Interface Identifier Value\*\*

Connected Line ID Presentation (QSIG Inbound Call)\*

### UUIE Configuration

- Passing Precedence Level Through UUIE

Security Access Level

### Product Specific Configuration

Clock Reference*	<input type="text" value="Network"/>
TX-Level CSU*	<input type="text" value="0dB"/>
FDL Channel*	<input type="text" value="ATT 54016"/>
Framing*	<input type="text" value="ESF"/>
Audio Signal Adjustment into IP Network*	<input type="text" value="NoDbPadding"/>
Audio Signal Adjustment from IP Network*	<input type="text" value="NoDbPadding"/>
Yellow Alarm*	<input type="text" value="Bit2"/>
Zero Suppression*	<input type="text" value="B8ZS"/>
Digit On Duration(50-500ms)*	<input type="text" value="100"/>
Interdigit Duration(50-500msec)*	<input type="text" value="100"/>
SNMP Community String	<input type="text" value="public"/>
Disable SNMP Set operations*	<input type="checkbox"/>
Debug Port Enable*	<input checked="" type="checkbox"/>
Hold Tone Silence Duration*	<input type="text" value="0"/>
Port Used for Voice Calls*	<input checked="" type="checkbox"/>
Port Used for Modem Calls*	<input checked="" type="checkbox"/>
Port Used for Fax Calls*	<input checked="" type="checkbox"/>



### Fax and Modem Parameters

Fax Relay Enable*	<input checked="" type="checkbox"/>
Fax Error Correction Mode Override*	<input checked="" type="checkbox"/>
Maximum Fax Rate*	14400bps
Fax Payload Size*	20
Non Standard Facilities Country Code*	65535
Non Standard Facilities Vendor Code*	65535
Fax/Modem Packet Redundancy*	<input type="checkbox"/>
NSE Type*	Non-IOS Gateways

### Playout Delay Parameters

Initial Playout Delay*	40
Minimum Playout Delay*	20
Maximum Playout Delay*	150

### Echo Canceller Configuration

Echo TailLength (ms)*	32 ms
Minimum ERL (db)*	6 db

\* indicates required item

\*\* applicable to DMS-100 protocol only

\*\*\* applicable to DMS-100 protocol and DMS-250 protocol only



Cisco CallManager QSIG-related Service Parameters Configuration

**Clusterwide Parameters (Feature - Forward)**

Parameter Name	Parameter Value	Suggested Value
Forward Maximum Hop Count*	<input type="text" value="12"/>	12
Forward No Answer Timer (sec)*	<input type="text" value="12"/>	12
Max Forward Hops to DN*	<input type="text" value="12"/>	12
Retain Forward Information*	<input type="text" value="False"/>	False
Forward By Reroute Enabled*	<input type="text" value="True"/>	False
Forward By Reroute T1 Timer (sec)*	<input type="text" value="10"/>	10
Include Original Called Info for Q.SIG Call Diversions*	<input type="text" value="Always"/>	Only after the first diversion



### Clusterwide Parameters (Feature - Path Replacement)

Parameter Name	Parameter Value	Suggested Value
Path Replacement Enabled*	<input type="text" value="True"/>	False
Path Replacement on Tromboned Calls*	<input type="text" value="True"/>	True
Start Path Replacement Minimum Delay Time (sec)*	<input type="text" value="0"/>	0
Start Path Replacement Maximum Delay Time (sec)*	<input type="text" value="0"/>	0
Path Replacement T1 Timer (sec)*	<input type="text" value="30"/>	30
Path Replacement T2 Timer (sec)*	<input type="text" value="15"/>	15
Path Replacement PINX ID	<input type="text" value="5555"/>	



## Appendix A

### CallManager Software Release

 When reporting or troubleshooting a problem, please give the following information to Technical Assistance:

Cisco CallManager System version: 4.1(2.14)  
Cisco CallManager Administration version: 4.1(0.11)  
Cisco CallManager Installation ID: CCM4.1(2.14)

Database Information  
DSN: CiscoCallManager  
SERVER: CM-NEPTUNE  
DATABASE: CCM0301

### Avaya Definity G3 Software Releases

```
list configuration software-versions Page 1
      SOFTWARE VERSIONS
      SPE_A          SPE_B

  UPDATE FILE
Creation (GMT) Date: none
  Old Version: none
  Old Identifier: none
  New Identifier: none
  Update State: none in memory

  SOFTWARE VERSION
Memory Resident: R011i.03.0.526.5
Mem Card Resident: none
Update Identifier: none

  TRANSLATION DATE
Memory Resident: date invalid
Mem Card Resident: date invalid

press CANCEL to quit -- press NEXT PAGE to continue
```



```
list configuration software-versions Page 1

          SOFTWARE VERSIONS
          SPE_A          SPE_B

UPDATE FILE
Creation (GMT) Date: none
  Old Version: none
  Old Identifier: none
  New Identifier: none
  Update State: none in memory

SOFTWARE VERSION
Memory Resident: R012i.00.1.221.1
Mem Card Resident: none
Update Identifier: none

TRANSLATION DATE
Memory Resident: 1:00 am WED OCT 20, 2004
Mem Card Resident: 1:00 am WED OCT 20, 2004

press CANCEL to quit -- press NEXT PAGE to continue
```

Intuity AUDIX Software Releases

```
Intuity Software Display (p1 of 2)

High level packages installed on audix in alphabetical order

APPLset      5.1-16  AUDIX(R) Application Set
AUDIXset     3.2-30  INTUITY Platform AUDIX Set
LANset       3.2-20.7  INTUITY SWIN LANset
RMBset       3.2-30  INTUITY RMB V2 set
UNIXfix      2.1-7   INTUITY SCO UnixWare 2.1.3 Enhancement/Fix Set
audixcd      ia5.1.16  Intuity AUDIX CD Versioning Package
french-c     R5.1-4   French-c System Announcements
html         5.1-16   Intuity html server and browser
* lat-span   R5.1-5   Lat-Span System Announcements
swmgmt       5.1-16   Software Management
syseval      5.1-16   System Evaluation Utility
upgset       5.1-16   Intuity Upgrade Utility
us-eng       R5.1-7   US-ENG System Announcements
us-tdd       R5.1-4   US-Tdd System Announcements

Display software in Package priority order
Display software installation time

-- press space for more, use arrow keys to move, <enter> to activate.
```



Unix Software Display (p1 of 10)

Unix software installed on audix

APPLset	5.1-16	AUDIX(R) Application Set
AUDIXset	3.2-30	INTUITY Platform AUDIX Set
AUDIXtune	3.2-30	INTUITY Platform AUDIX Tuning
FlexTool	3.2-30	INTUITY FlexWord Toolkit
LANset	3.2-20.7	INTUITY SWIN LANset
Perl	Version 5.003	Perl
RMBset	3.2-30	INTUITY RMB V2 set
TSM	3.2-30	INTUITY Transaction State Machine Package
UNIXfix	2.1-7	INTUITY SCO UnixWare 2.1.3 Enhancement/Fix Set
UPGsw	5.1-16	Intuity Upgrade Software
UPGvm	5.1-16	VM upgrade package
UnixWare	2.1	UnixWare Set
VM-dfltodb	5.1-16	AUDIX(R) Default db with POET
VM-files	5.1-16	AUDIX(R) Files
VM-sw	5.1-16	AUDIX(R) Software
VM	NA	AUDIX(R) Module marker file
acl	2.1	Access Control List Utilities
acp	2.1	Enhanced Application Compatibility

-- press space for more, use arrow keys to move, <enter> to activate.



### Cisco Catalyst 6500 Switch Configuration

```
Console> (enable) sh version
WS-C6506 Software, Version NmpSW: 7.6(8)
Copyright (c) 1995-2004 by Cisco Systems
NMP S/W compiled on Jul 15 2004, 19:13:13
```

```
System Bootstrap Version: 5.3(1)
System Boot Image File is 'bootflash:cat6000-supk8.7-6-8.bin'
System Configuration register is 0x2102
```

```
Hardware Version: 2.0 Model: WS-C6506 Serial #: TBA04110341
```

```
PS1 Module: WS-CAC-1300W Serial #: SON04080868
```

Mod	Port	Model	Serial #	Versions
1	2	WS-X6K-SUP1A-2GE	SAD041504XL	Hw : 3.1 Fw : 5.3(1) Fw1: 5.1(1)CSX Sw : 7.6(8) Sw1: 7.6(8)
		WS-F6K-PFC	SAD0413097K	Hw : 1.1 Sw :
		WS-X6K-SUP1A-2GE	SAD041504XL	Hw : 3.1 Sw :
2	48	WS-X6348-RJ-45	SAL0708D6FK	Hw : 6.2 Fw : 5.4(2) Sw : 7.6(8)
		WS-F6K-VPWR		Hw : 2.0 Sw : 1.0
3	5	WS-SVC-CMM	SAD0825030S	Hw : 2.5 Fw : 12.2(13)ZP3, Sw : 12.2(13)ZP3,
4	24	WS-X6624-FXS	SAD050203M8	Hw : 3.0 Fw : 5.4(2) Sw : 7.6(8) HP : A00204000005; DSP : A0034133 (4.1.
33)				
5	8	WS-X6608-E1	SAD043300AJ	Hw : 1.1 Fw : 5.4(2) Sw : 7.6(8) HP1: D00404000006; DSP1: D0054133 (4.1.
33)				HP2: D00404000006; DSP2: D0054133 (4.1.
33)				HP3: D00404000006; DSP3: D0054133 (4.1.
33)				HP4: D00404000006; DSP4: D0054133 (4.1.
33)				HP5: D00404000011; DSP5: D0054140 (4.1.
40)				HP6: D00404000011; DSP6: D0054140 (4.1.
40)				HP7: D00404000011; DSP7: D0054140 (4.1.
40)				HP8: C00103010014; DSP8: C002E031 (3.3.



```

2)
6 8 WS-X6608-T1 SAD080303C2 Hw : 1.4
                               Fw : 5.4(2)
                               Sw : 7.6(8)
                               HP1: D00404000006; DSP1: D0054133 (4.1.
33)
                               HP2: D00404000006; DSP2: D0054133 (4.1.
33)
                               HP3: D00404000006; DSP3: D0054133 (4.1.
33)
                               HP4: D00404000006; DSP4: D0054133 (4.1.
33)
                               HP5: D00404000011; DSP5: D0054140 (4.1.
40)
                               HP6: D00404000011; DSP6: D0054140 (4.1.
40)
                               HP7: D00404000011; DSP7: D0054140 (4.1.
40)
                               HP8: D00404000011; DSP8: D0054140 (4.1.
40)

```

	DRAM			FLASH			NVRAM		
Module	Total	Used	Free	Total	Used	Free	Total	Used	Free
1	65408K	46141K	19267K	16384K	15489K	895K	512K	293K	219K

Uptime is 21 days, 19 hours, 22 minute

Console> (enable) **sh module**

Mod	Slot	Ports	Module-Type	Model	Sub	Status
1	1	2	1000BaseX Supervisor	WS-X6K-SUP1A-2GE	yes	ok
2	2	48	10/100BaseTX Ethernet	WS-X6348-RJ-45	yes	ok
3	3	5	Communication Media Mod.	WS-SVC-CMM	no	other
4	4	24	FXS	WS-X6624-FXS	no	ok
5	5	8	E1	WS-X6608-E1	no	ok
6	6	8	T1	WS-X6608-T1	no	ok

Mod	Module-Name	Serial-Num
1		SAD041504XL
2		SAL0708D6FK
3		SAD0825030S
4		SAD050203M8
5		SAD043300AJ
6		SAD080303C2

Mod	MAC-Address(es)	Hw	Fw	Sw
1	00-d0-d3-37-f9-8e to 00-d0-d3-37-f9-8f 00-d0-d3-37-f9-8c to 00-d0-d3-37-f9-8d 00-01-63-af-5c-00 to 00-01-63-af-5f-ff	3.1	5.3(1)	7.6(8)
2	00-0c-30-44-30-30 to 00-0c-30-44-30-5f	6.2	5.4(2)	7.6(8)
3	00-11-5c-28-e8-bc to 00-11-5c-28-e8-c5	2.5	12.2(13)ZP	12.2(13)ZP3,
4	00-03-32-ba-2e-35	3.0	5.4(2)	7.6(8)
5	00-01-64-12-22-80 to 00-01-64-12-22-87	1.1	5.4(2)	7.6(8)
6	00-0e-38-79-ae-f6 to 00-0e-38-79-ae-fd	1.4	5.4(2)	7.6(8)



```

Mod Sub-Type                Sub-Model                Sub-Serial  Sub-Hw  Sub-Sw
-----
1   L3 Switching Engine    WS-F6K-PFC              SAD0413097K 1.1
2   Inline Power Module    WS-F6K-VPWR              2.0      1.0
Console> (enable)

```

```

Console> (enable) sh port 3
* = Configured MAC Address

```

Port	Name	Status	Vlan	Duplex	Speed	Type
3/1		connected	231	full	1000	1000BaseT
3/2		notconnect	231	full	100	100BaseTX
3/3		notconnect	1	full	100	100BaseTX
3/4		notconnect	1	full	100	100BaseTX
3/5		notconnect	1	full	100	100BaseTX

Port	Trap	IfIndex
3/1	disabled	111
3/2	disabled	112
3/3	disabled	113
3/4	disabled	114
3/5	disabled	115

Port	Status	ErrDisable Reason	Port ErrDisableTimeout	Action on Timeout
3/1	connected	-	Enable	No Change
3/2	notconnect	-	Enable	No Change
3/3	notconnect	-	Enable	No Change
3/4	notconnect	-	Enable	No Change
3/5	notconnect	-	Enable	No Change

```

Console> (enable)

```

```

Console> (enable) sh vlan

```

VLAN	Name	Status	IfIndex	Mod/Ports, Vlans
1	default	active	5	1/1-2
32	VLAN0032	active	104	2/1
66	VLAN0066	active	105	
225	VLAN0225	active	102	2/2, 2/4-12, 2/14-24 4/1-24 5/1-4 6/1-4
231	VLAN0231	active	110	2/25-48 5/5-8 6/5-8
700	VLAN0700	active	109	2/13
1002	fddi-default	active	6	
1003	token-ring-default	active	9	
1004	fddinet-default	active	7	
1005	trnet-default	active	8	



VLAN	Type	SAID	MTU	Parent	RingNo	BrdgNo	Stp	BrdgMode	Trans1	Trans2
1	enet	100001	1500	-	-	-	-	-	0	0
32	enet	100032	1500	-	-	-	-	-	0	0
66	enet	100066	1500	-	-	-	-	-	0	0
225	enet	100225	1500	-	-	-	-	-	0	0
231	enet	100231	1500	-	-	-	-	-	0	0
700	enet	100700	1500	-	-	-	-	-	0	0
1002	fddi	101002	1500	-	-	-	-	-	0	0
1003	trcrf	101003	1500	-	-	-	-	-	0	0
1004	fdnet	101004	1500	-	-	-	-	-	0	0
1005	trbrf	101005	1500	-	-	-	ibm	-	0	0

VLAN	MISTP-Inst	DynCreated	RSPAN
1	-	static	disabled
32	-	static	disabled
66	-	static	disabled
225	-	static	disabled
231	-	static	disabled
700	-	static	disabled
1002	-	static	disabled
1003	-	static	disabled
1004	-	static	disabled
1005	-	static	disabled

```
VLAN AREHops STEHops Backup CRF lq VLAN
-----
1003 7 7 off
Console> (enable)
```

```
Console> (enable) sh config
This command shows non-default configurations only.
Use 'show config all' to show both default and non-default configurations.
```

```
.....
.....
.....
.....
.....
..
begin
!
# ***** NON-DEFAULT CONFIGURATION *****
!
!
#time: Wed Sep 15 2004, 12:40:15
!
#version 7.6(8)
!
```



```
!  
#dot1x  
set dot1x shutdown-timeout 0  
!  
#!  
#vtp  
set vtp mode transparent  
set vlan 1 name default type ethernet mtu 1500 said 100001 state active  
set vlan 1002 name fddi-default type fddi mtu 1500 said 101002 state active  
set vlan 1004 name fddinet-default type fddinet mtu 1500 said 101004 state activ  
e stp ieee  
set vlan 1005 name trnet-default type trbrf mtu 1500 said 101005 state active st  
p ibm  
set vlan 32,66,225,231,700  
set vlan 1003 name token-ring-default type trcrf mtu 1500 said 101003 state acti  
ve mode srb aremaxhop 7 stemaxhop 7 backupcrf off  
!  
#ip  
set interface sc0 225 172.20.31.20/255.255.255.0 172.20.31.255  
  
set interface sc1 0 0.0.0.0/0.0.0.0 0.0.0.0  
  
set interface sc1 down  
set ip route 0.0.0.0/0.0.0.7 172.20.31.1  
set ip alias default 0.0.0.0  
!  
#spanntree  
#vlan parameters  
set spanntree fwddelay 15 1003  
set spanntree maxage 20 1003  
set spanntree disable 1005  
set spanntree fwddelay 15 1005  
set spanntree maxage 20 1005  
!  
#syslog  
set logging level ld 2 default  
set logging level privatevlan 2 default  
set logging level ethc 2 default  
set logging level gl2pt 2 default  
!  
#set boot command  
set boot config-register 0x2102  
set boot system flash bootflash:cat6000-supk8.7-6-8.bin  
!  
#igmp  
set igmp disable  
!  
#qos  
set qos enable  
set qos wrr 2q2t 5 255  
set qos wrr lp2q2t 5 255  
set qos wred lp2q2t tx queue 1 40:80 70:100  
set qos wred lp2q2t tx queue 2 40:80 70:100  
clear qos acl all  
#IP_PHONE_SCCP  
set qos acl ip IP_PHONE_SCCP dscp 26 tcp any any range 2000 2002  
#
```



```
commit qos acl all
!
# default port status is enable
!
!
#module 1 : 2-port 1000BaseX Supervisor
!
#module 2 : 48-port 10/100BaseTX Ethernet
set vlan 32 2/1,2/3
set vlan 225 2/2,2/4-12,2/14-24
set vlan 231 2/25-48
set vlan 700 2/13
set port speed 2/1,2/3 100
set port duplex 2/1,2/3 full
set trunk 2/1 desirable dot1q 1-1005,1025-4094
!
#module 3 : 5-port Communication Media Mod.
set vlan 231 3/1-2
!
#module 4 : 24-port FXS
set port voice interface 4/1-24 dhcp enable vlan 225
!
#module 5 : 8-port E1
set port voice interface 5/1 dhcp enable vlan 225
set port voice interface 5/2 dhcp enable vlan 225
set port voice interface 5/3 dhcp enable vlan 225
set port voice interface 5/4 dhcp enable vlan 225
set port voice interface 5/5 dhcp enable vlan 231
set port voice interface 5/6 dhcp enable vlan 231
set port voice interface 5/7 dhcp enable vlan 231
set port voice interface 5/8 dhcp enable vlan 231
!
#module 6 : 8-port T1
set port voice interface 6/1 dhcp enable vlan 225
set port voice interface 6/2 dhcp enable vlan 225
set port voice interface 6/3 dhcp enable vlan 225
set port voice interface 6/4 dhcp enable vlan 225
set port voice interface 6/5 dhcp enable vlan 231
set port voice interface 6/6 dhcp enable vlan 231
set port voice interface 6/7 dhcp enable vlan 231
set port voice interface 6/8 dhcp enable vlan 231
!
#module 15 empty
!
#module 16 empty
end
```

---

## Acronyms

Acronym	Definitions
ANF-PR	Additional Network Feature Path Replacement



Acronym	Definitions
AOC	Advice-of-charge. Information element is sent with the connection setup information for incoming Euro-ISDN connections. The AOC IE is used for call charge calculation.
CCM	Cisco Unified CallManager
CCBS	Call Completion to Busy Subscriber
CCNR	Call Completion on No Reply
CFB	Call Forwarding on Busy
CFNR	Call Forwarding No Reply
CFU	Call Forwarding Unconditional
CLIP	Calling Line (Number) Identification Presentation
CLIR	Calling Line (Number) Identification Restriction
CMM	Communication Media Module (CMM) is a Cisco Catalyst® 6500 Series and Cisco 7600 Series line card that provides flexible and high-density T1/E1 gateways
CNIP	Calling Name Identification Presentation
CNIR	Calling Name Identification Restriction
CNIR	Calling Name Identification Restriction
COLP	Connected Line (Number) Identification Presentation
COLR	Connected Line (Number) Identification Restriction
CONP	Connected Name Identification Presentation
CONR	Connected Name Identification Restriction
CT	Call Transfer
MWI	Message Waiting Indicator
PSTN	Public Switched Telephone Network



## Important Information

THE SPECIFICATIONS AND INFORMATION REGARDING THE PRODUCTS IN THIS MANUAL ARE SUBJECT TO CHANGE WITHOUT NOTICE. ALL STATEMENTS, INFORMATION, AND RECOMMENDATIONS IN THIS MANUAL ARE BELIEVED TO BE ACCURATE BUT ARE PRESENTED WITHOUT WARRANTY OF ANY KIND, EXPRESS OR IMPLIED. USERS MUST TAKE FULL RESPONSIBILITY FOR THEIR APPLICATION OF ANY PRODUCTS.

IN NO EVENT SHALL CISCO OR ITS SUPPLIERS BE LIABLE FOR ANY INDIRECT, SPECIAL, CONSEQUENTIAL, OR INCIDENTAL DAMAGES, INCLUDING, WITHOUT LIMITATION, LOST PROFITS OR LOSS OR DAMAGE TO DATA ARISING OUT OF THE USE OR INABILITY TO USE THIS MANUAL, EVEN IF CISCO OR ITS SUPPLIERS HAVE BEEN ADVISED OF THE POSSIBILITY OF SUCH DAMAGES.



### Corporate Headquarters

Cisco Systems, Inc.  
170 West Tasman Drive  
San Jose, CA 95134-1706  
USA  
www.cisco.com  
Tel: 408 526-4000  
800 553-NETS (6387)  
Fax: 408 526-4100

### European Headquarters

Cisco Systems International  
BV  
Haarlerbergpark  
Haarlerbergweg 13-19  
1101 CH Amsterdam  
The Netherlands  
www-europe.cisco.com  
Tel: 31 0 20 357 1000  
Fax: 31 0 20 357 1100

### Americas Headquarters

Cisco Systems, Inc.  
170 West Tasman Drive  
San Jose, CA 95134-1706  
USA  
www.cisco.com  
Tel: 408 526-7660  
Fax: 408 527-0883

### Asia Pacific Headquarters

Cisco Systems, Inc.  
Capital Tower  
168 Robinson Road  
#22-01 to #29-01  
Singapore 068912  
www.cisco.com  
Tel: +65 317 7777  
Fax: +65 317 7799

Cisco Systems has more than 200 offices in the following countries and regions. Addresses, phone numbers, and fax numbers are listed on the Cisco Web site at [www.cisco.com/go/offices](http://www.cisco.com/go/offices).

Argentina • Australia • Austria • Belgium • Brazil • Bulgaria • Canada • Chile • China PRC • Colombia • Costa Rica • Croatia • Czech Republic • Denmark • Dubai, UAE • Finland • France • Germany • Greece • Hong Kong SAR • Hungary • India • Indonesia • Ireland • Israel • Italy • Japan • Korea • Luxembourg • Malaysia • Mexico • The Netherlands • New Zealand • Norway • Peru • Philippines • Poland • Portugal • Puerto Rico • Romania • Russia • Saudi Arabia • Scotland • Singapore • Slovakia • Slovenia • South Africa • Spain • Sweden • Switzerland • Taiwan • Thailand • Turkey • Ukraine • United Kingdom • United States • Venezuela • Vietnam • Zimbabwe

© 2007 Cisco Systems, Inc. All rights reserved.

CCVP, the Cisco logo, and the Cisco Square Bridge logo are trademarks of Cisco Systems, Inc.; Changing the Way We Work, Live, Play, and Learn is a service mark of Cisco Systems, Inc.; and Access Registrar, Aironet, BPX, Catalyst, CCDA, CCDP, CCIE, CCIP, CCNA, CCNP, CCSP, Cisco, the Cisco Certified Internetwork Expert logo, Cisco IOS, Cisco Press, Cisco Systems, Cisco Systems Capital, the Cisco Systems logo, Cisco Unity, Enterprise/Solver, EtherChannel, EtherFast, EtherSwitch, Fast Step, Follow Me Browsing, FormShare, GigaDrive, HomeLink, Internet Quotient, IOS, iPhone, IP/TV, iQ Expertise, the iQ logo, iQ Net Readiness Scorecard, iQuick Study, LightStream, Linksys, MeetingPlace, MGX, Networking Academy, Network Registrar, Packet, PIX, ProConnect, ScriptShare, SMARTnet, StackWise, The Fastest Way to Increase Your Internet Quotient, and TransPath are registered trademarks of Cisco Systems, Inc. and/or its affiliates in the United States and certain other countries.

All other trademarks mentioned in this document or Website are the property of their respective owners. The use of the word partner does not imply a partnership relationship between Cisco and any other company. (0705R)

Printed in the USA

