

## Cisco Industrial IoT Solutions

# Solutions for Industries



## Rail Solutions

Transforming passenger experiences and rail operations with secure, reliable connectivity



Railway infrastructure, rail vehicles, and passenger volumes continue to grow globally. Rail operators must ensure the safety of workers, passengers, and the public while at the same time keeping trains running on time, providing superior service, and minimizing operational costs. To achieve these business objectives, rail equipment and infrastructure owners can take advantage of increasingly advanced technology to address safety concerns, improve asset visibility, offer new value-added services, increase ridership, and reduce operating expenses. Cisco helps by providing a strong networking foundation to help them achieve their goals.

### How Cisco industrial IoT solutions help

Cisco has a long track record of delivering reliable and secure network infrastructure for the railway industry globally. A highly available, reliable, and secure network helps ensure passenger and worker safety while providing operational efficiency and superior service. Cisco's strength comes from its many years of being a leader in the networking industry. Wireless solutions are key for signal control, railroad crossing control, surveillance cameras, passenger Wi-Fi, asset remote condition monitor and, worker devices. Cisco Ultra-Reliable Wireless Backhaul (URWB) delivers high throughput, low latency, and seamless handoffs, even for vehicles moving at high speed.

## Connectivity to trackside infrastructure

Cisco industrial networking products are purpose-built for the harshest environments, with the ability to withstand extreme temperatures, water, dust, and vibration. This makes them ideal for trackside connectivity. Catalyst Industrial Ethernet switches are used to connect to optical fiber along the tracks. Catalyst Industrial Wireless access points that support URWB or Catalyst industrial routers with cellular connectivity are used to provide reliable wireless connectivity where running fiber is not possible or is too costly, making it possible to support both vital and non-vital applications in the most remote locations.

## Train-to-wayside connectivity

The Cisco Catalyst IW9167E and IW9165E access points are the ideal combination to provide a trackside train-to-ground system. This solution offers reliable wireless connectivity, even for high-speed trains, to support Communication-Based Train Control (CBTC), video data offload, onboard Wi-Fi, and real-time security video monitoring, situational awareness, and more.

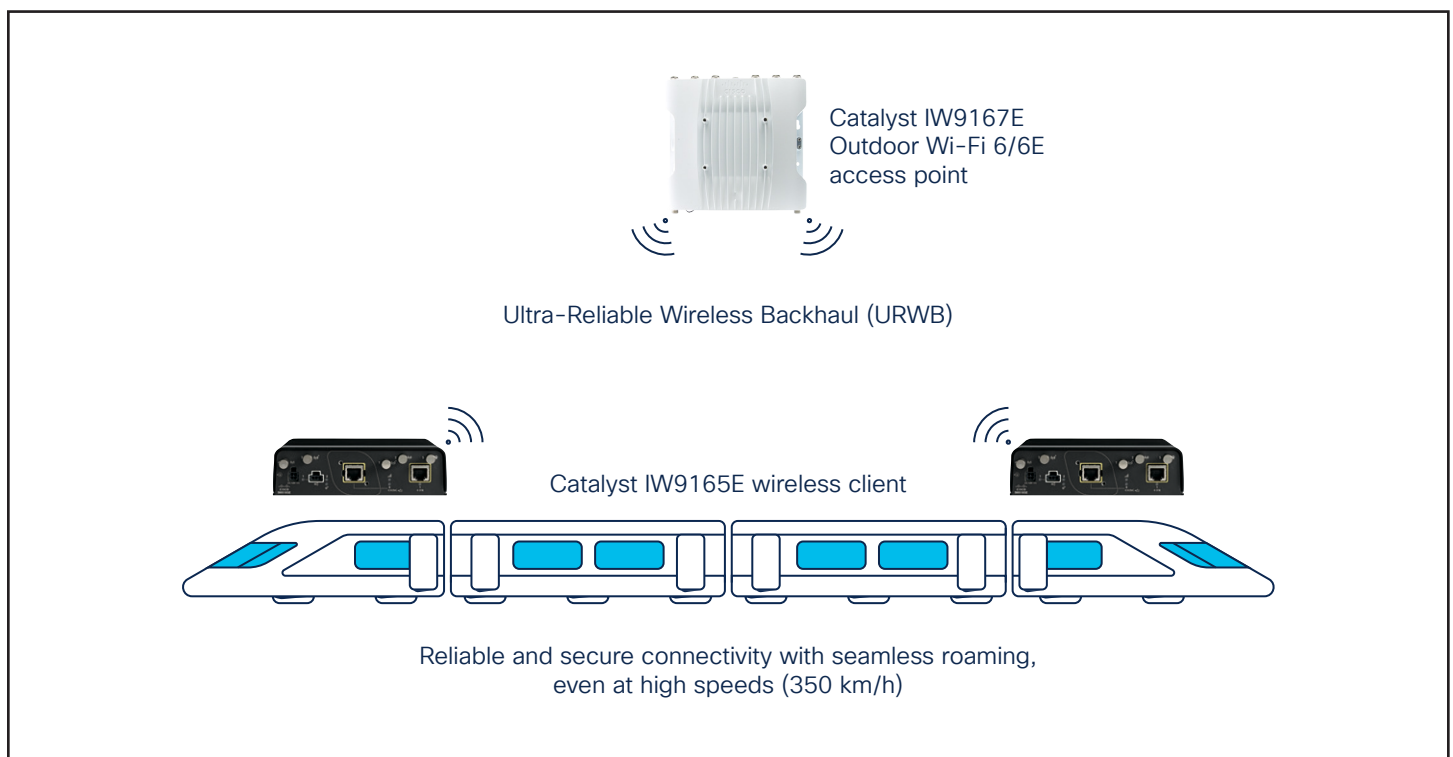

## Connected Rail solutions

Onboard, station, and trackside connectivity

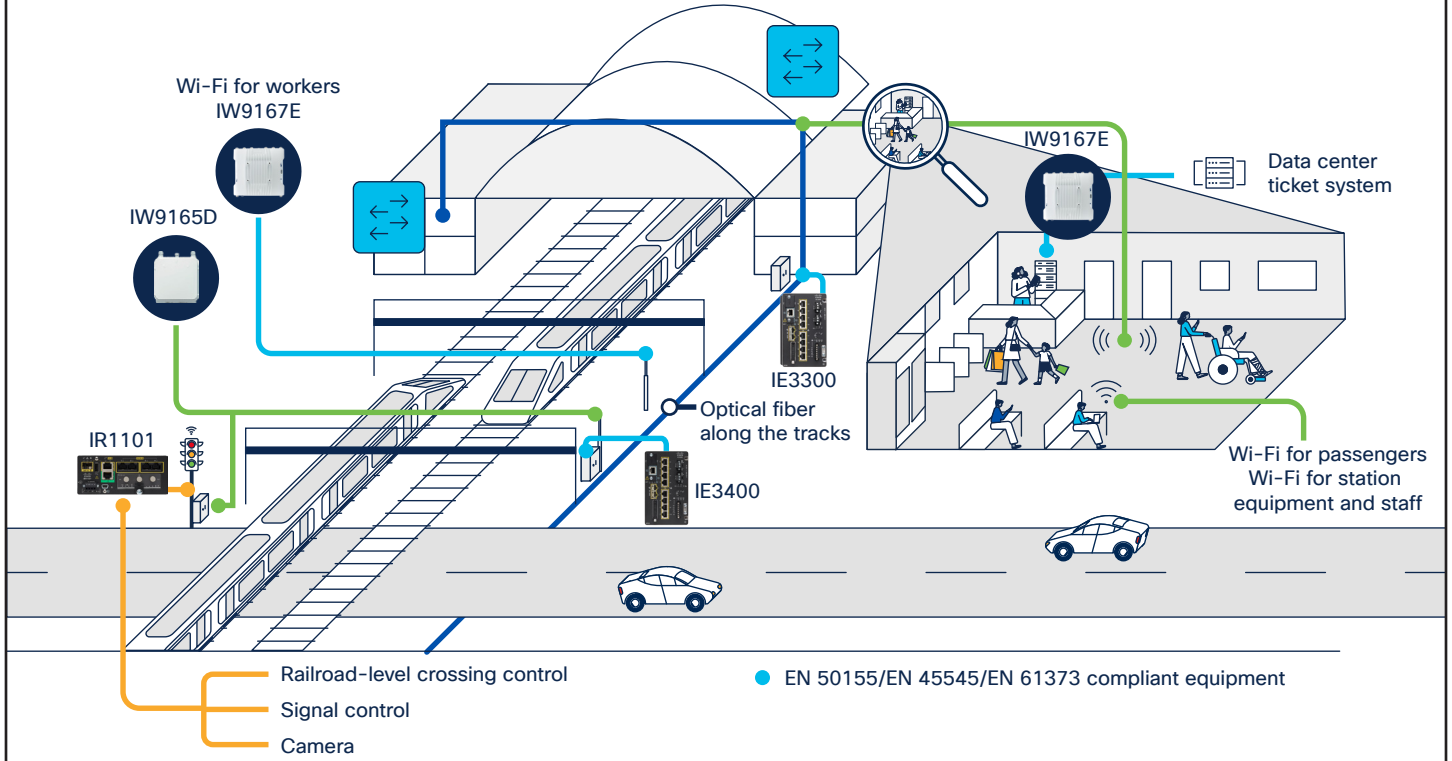

## Trackside and inter-car network

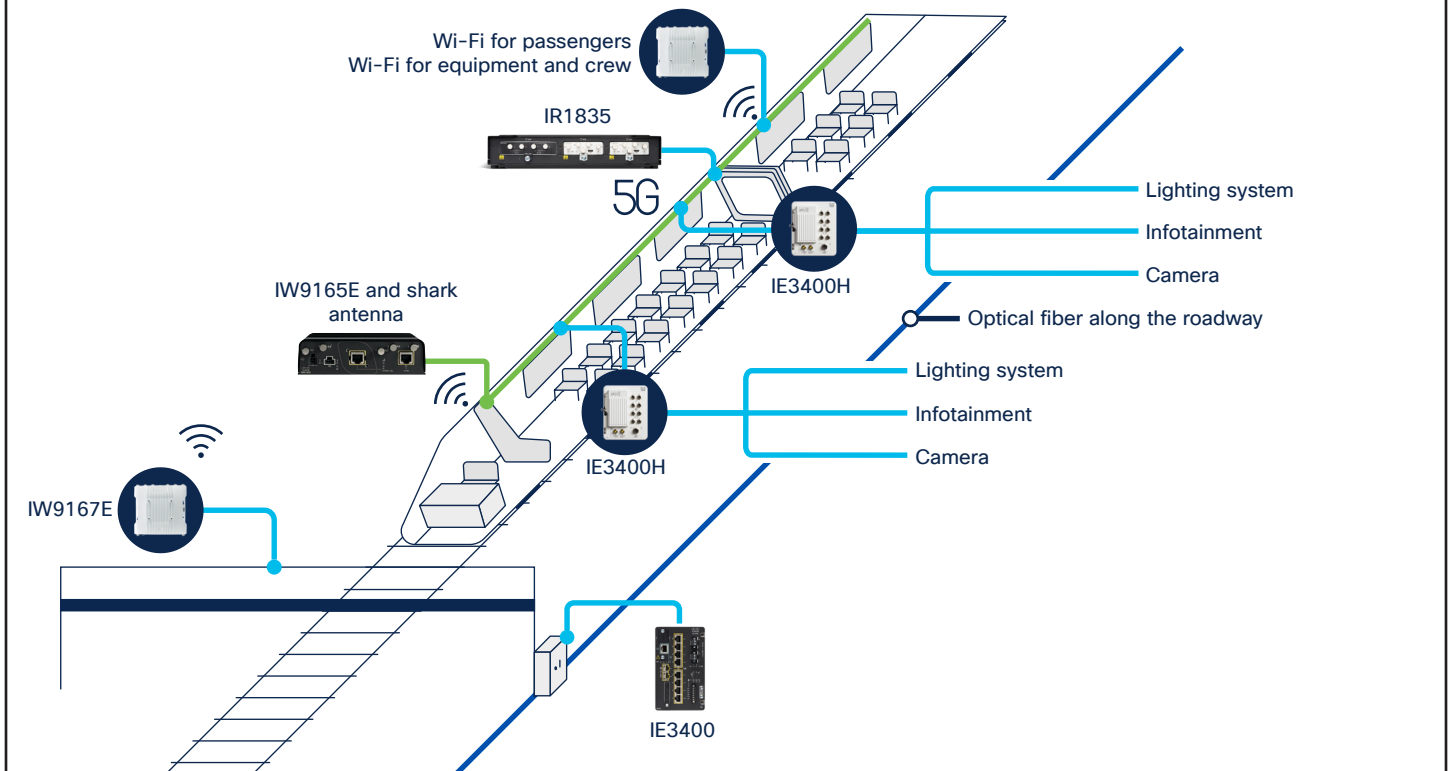

## Smart manufacturing

### Manufacturing solutions overview and benefits



In their pursuit of industry 4.0's potential, manufacturers are embracing digitization. This digital transformation empowers them to enhance efficiency, gain valuable insights, and safeguard their operations. Industrial IoT, AI, robotics, and zero-trust cybersecurity are key technologies facilitating these advancements. To fully realize these benefits, a robust industrial network infrastructure is crucial. This network must be scalable, secure, seamlessly connect to enterprise systems, and utilize reliable, low-latency wireless technology.

### Cisco solutions for manufacturers

Cisco empowers manufacturers to achieve their smart manufacturing goals by providing a high-performance and resilient industrial network. This network leverages our established enterprise network architecture, helping ensure seamless integration with existing IT infrastructure and using tools already familiar to IT teams, thereby minimizing training requirements and streamlining network management.

### Build a robust foundation for smart manufacturing

Cisco Catalyst™ Industrial Ethernet (IE) switches constitute the foundational element of industrial networking infrastructure. These versatile switches offer deployment flexibility with DIN-rail, rack-mount, and IP-67 rated wall-mount options. Designed for harsh industrial environments, Catalyst IE switches are ruggedized to withstand demanding conditions. They leverage the well-established and extensible Cisco IOS® XE operating system familiar to network administrators. Additionally, the intelligent Cisco Catalyst Center network management system streamlines network automation and assures performance. Furthermore, Catalyst IE switches support industrial communication protocols, including CC-Link IE, EtherNet/IP, PROFINET, and Modbus. They also facilitate network resilience through redundancy protocols such as Parallel Redundancy Protocol (PRP), Media Redundancy Protocol (MRP), and Device Level Ring (DLR).

## Unify OT security with networking

Cisco Catalyst IE switches promote a streamlined approach to industrial security by eliminating the need for additional dedicated security appliances. This is achieved through the integration of key security features as software functions:

- **Cisco® Cyber Vision Sensor:** Facilitates comprehensive asset, network traffic, and security vulnerabilities visibility within the industrial network.
- **Zero-Trust Network Access (ZTNA) gateway:** Enables secure remote access while adhering to zero-trust security principles.
- **Segmentation:** Enforces operations segmentation by creating secure zones and conduits, aligning with the industry standard ISA/IEC 62443 for industrial automation and control system security.

## Enable smart manufacturing innovations

Virtualization of hardware resources allows more efficient utilization of resources. While well accepted in the enterprise, virtualization in operations is considerably more complex. With a high-performing, resilient, secure, and deterministic network, Cisco industrial networking can provide uninterrupted connectivity between virtualized hardware and machines leading to lower OpEx, and greater flexibility.

Convergence between Operational Technology (OT) and Information Technology (IT) network equipment and

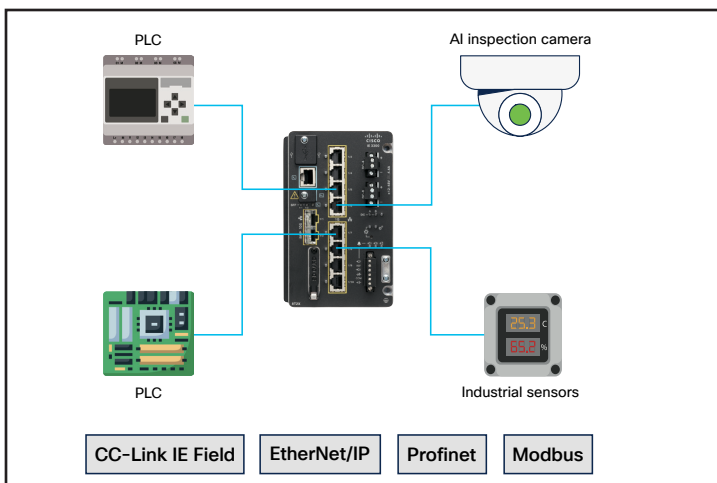

architectures facilitates a more seamless connection between the two domains. This enhanced connectivity enables the real-time flow of production data from OT to analytical applications in the IT domain. By leveraging this data stream, manufacturers can gain valuable insights, make informed decisions, and realize their AI strategies.

## Derive actionable insights from Splunk

Splunk offers significant value to manufacturing operations by providing a platform to centralize, analyze, and gain insights from a vast amount of data generated across various manufacturing systems. Splunk empowers manufacturers to transform their data into actionable insights. With these insights, manufacturers can improve efficiency and productivity, enhance quality control, obtain better supply chain visibility, mitigate security threats, etc.

## Add flexibility with reliable wireless

A reliable wireless connectivity solution is paramount for the effective operation of autonomous robots and vehicles. This solution must function effectively in environments with obstacles and radio frequency interference to ensure real-time responsiveness. Cisco Ultra-Reliable Wireless Backhaul (URWB) technology addresses these challenges by offering ultra-low latency and seamless handoffs between access points. Operating within the same unlicensed spectrum as Wi-Fi, it is the ideal choice for supporting the demanding requirements of autonomous systems.



### A converged security and network architecture for manufacturing

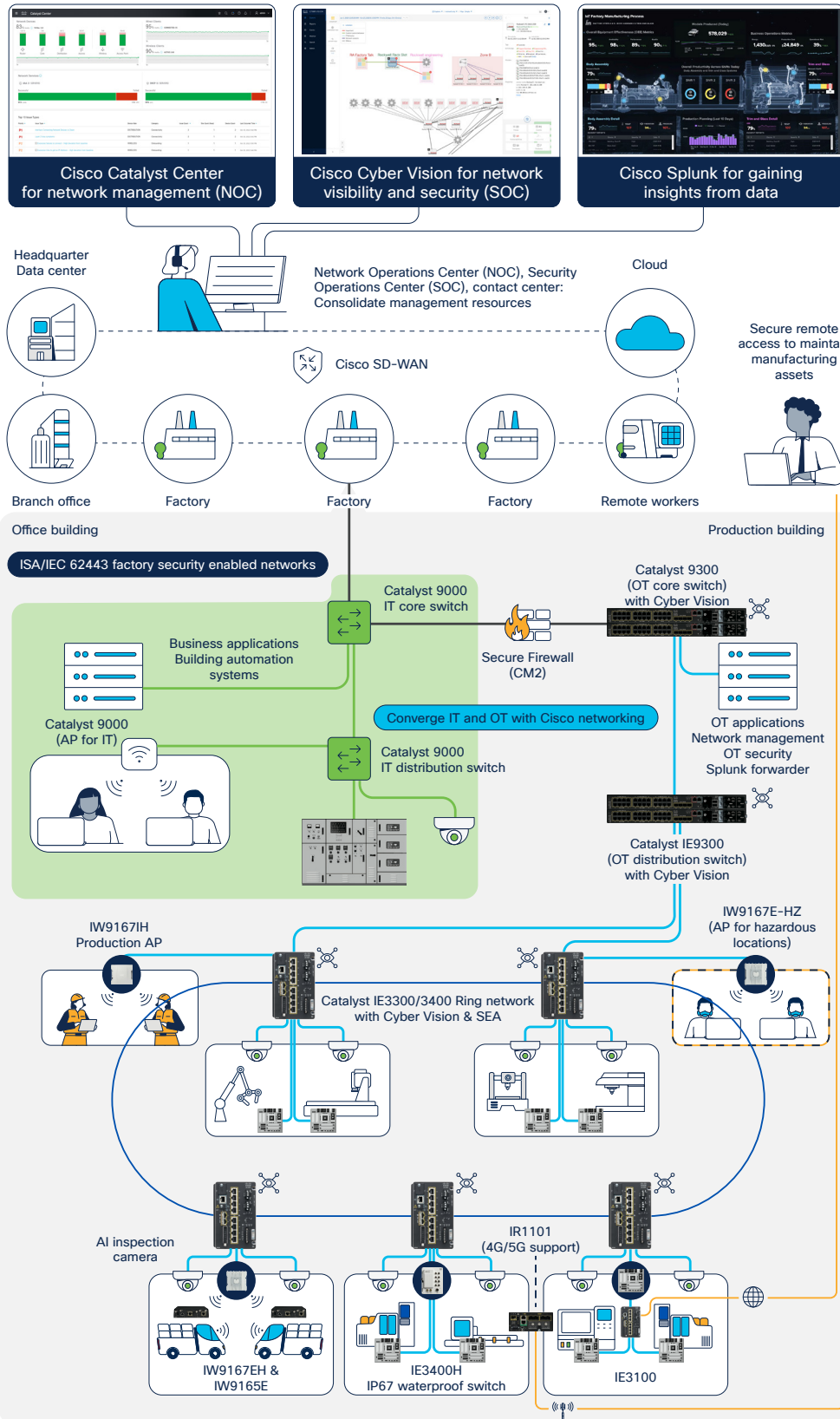

## Power utilities

Overview and benefits of power utility solutions

### Overview and benefits of Power utility solutions



Power utilities are undergoing a monumental shift toward grid modernization and are grappling with the need for a flexible and evolving grid as they face many challenges. These include the need to accelerate cybersecurity measures to safeguard operational technologies and critical infrastructures, update aging grids, integrate renewable energy resources, comply with tightening regulations, and meet increased energy demands – and amidst all these challenges loom the shortages of resources and skilled staff to get the work done.

## Cisco industrial IoT solutions for power utilities

A strategic and comprehensive approach is essential for effective grid modernization. Cisco's Industrial IoT team has been collaborating with utilities for over two decades, recognizing that a modern grid necessitates a modern network. Our focus is to provide industrial networking products and solutions built and certified for utility needs, helping ensure security, simplicity, and scalability for the modern grid.

### Substation automation

Cisco's substation automation solutions enhance remote monitoring of substation equipment and sensors, minimize service interruptions by providing greater visibility into where maintenance is needed, reduce costs by eliminating multiple leased lines, and help ensure compliance with security and industry standards, including IEC 61850. These benefits are delivered through products like the Cisco Catalyst IR8300 Rugged Series Router with Next Generation Firewall built-in, and IE9300 Rugged Series Switches, which provide the networking foundation for advanced control, diagnostics, and maintenance capabilities. Learn more in our [Cisco Validated Design and solution overview for Substation Automation](#).



## Network example for the power utility industry

Centralized management of substation LAN (Cisco Catalyst Center)

Centralized management of substation WAN (Cisco Catalyst SD-WAN Manager)

Cisco Splunk for gaining insights from data

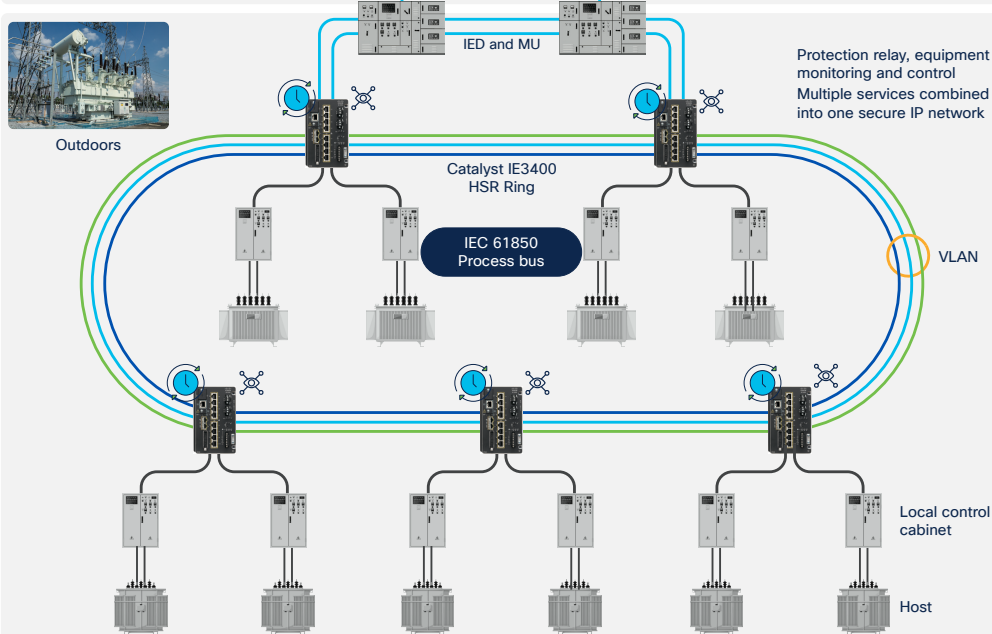
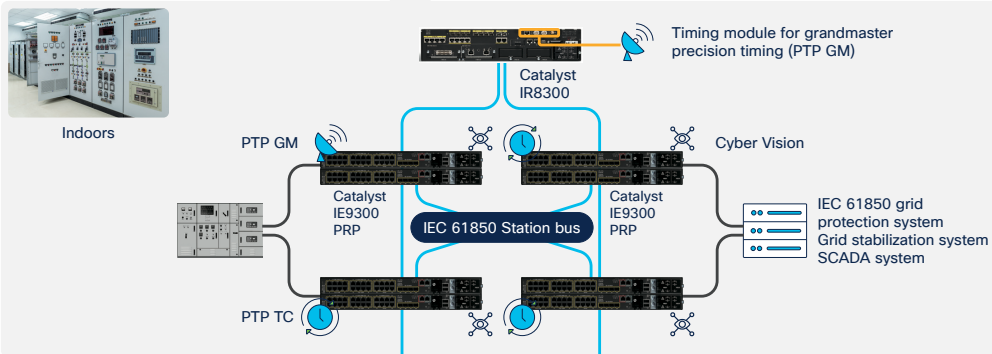
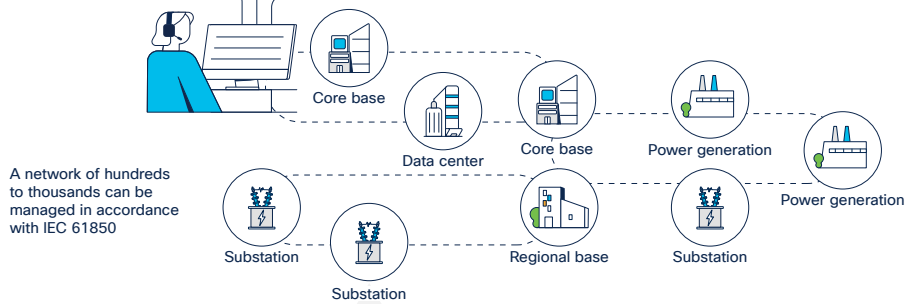

## Distribution grid automation

Multiservice data communications networks are essential to realizing the full potential of the smart grid. With Cisco® industrial IoT solutions, utilities can get the data they need to improve the operational efficiency, safety, and security of the distribution power system. Field area networks are powered by the Cisco industrial routing and switching portfolios, including the Cisco Catalyst IR1101 Rugged Router and Catalyst IE3X00 family of rugged switches. They support all the capabilities that drive the competitive edge of modern utilities, including high-efficiency Distribution Automation (DA), remote asset management, smart metering, and mobile workforce automation. Cisco multiservice networks are the foundation for enabling distributed power generation, including renewables such as solar and wind, energy storage, microgrids, and more.

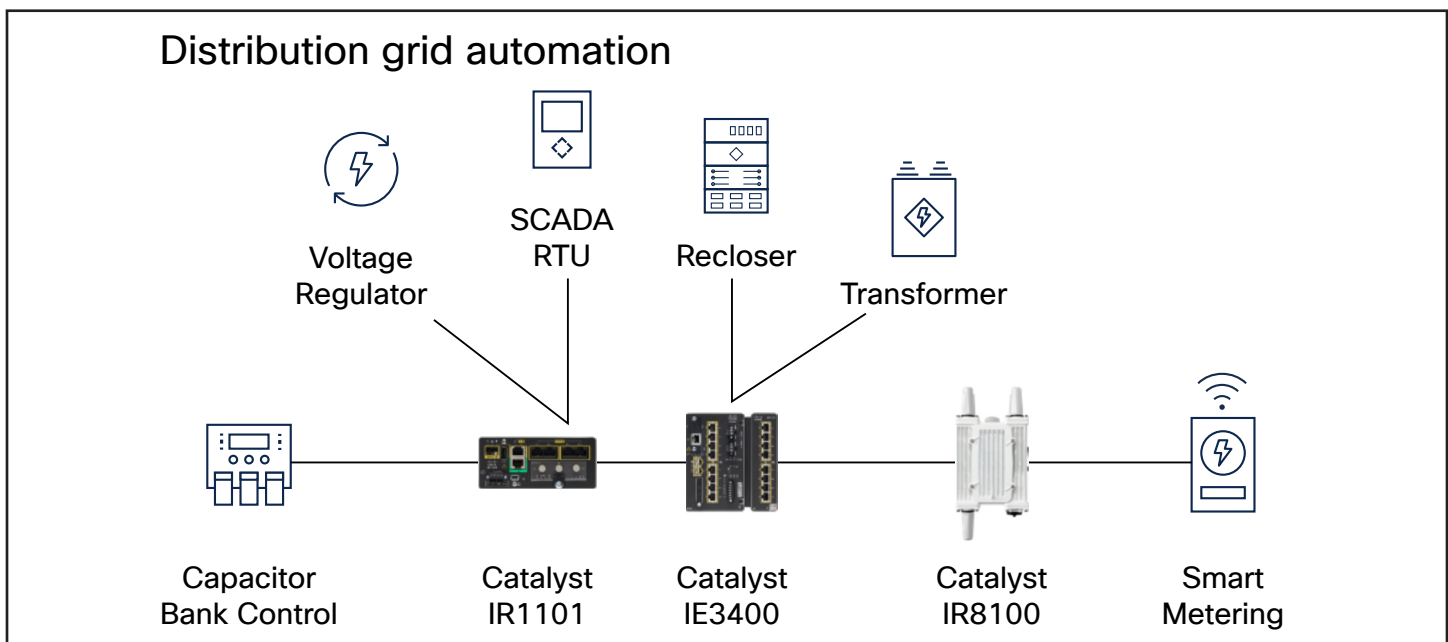

## Advanced metering infrastructure

Advanced metering infrastructure (AMI) is a critical part of any smart grid initiative, enabling utilities to obtain real-time power consumption data and allowing customers to make informed choices about energy usage. Unlike legacy electricity meters, AMI-based smart meters are capable of two-way communication with the utility network. Cisco is committed to open standards, and our AMI solutions are fully Wi-SUN compliant.

Our flexible AMI solutions enable utilities to:

- Scale to connect millions of smart meters
- Provide over-the-air meter firmware upgrades
- Remotely connect and disconnect power from meter to load
- Deliver power outage and restoration notifications
- Receive alerts when meters have been damaged

## Connected roadways and intersections



Departments of Transportation (DOTs), roadway authorities and cities around the globe are focusing on enhancing the safety of road users, especially vulnerable road users, reducing traffic congestion, and achieving climate change and sustainability goals. To meet these objectives, it's more important than ever to securely connect our critical roadways and intersections infrastructure and provide the visibility of roadways equipment and access to data that is necessary to optimize processes and pave the way to support emerging and innovative vehicle technologies including Cellular Vehicle-to-Everything (C-V2X) communication.

### Cisco industrial IoT solutions for connected roadways

Cisco understands the challenges that roadway owner-operators face and has extensive experience in the industry. Our validated solutions help organizations to securely connect critical roadway and intersection infrastructure at scale and support the successful digital transformation of roads, highways and intersections, while paving the way for new innovations.

Our solutions for roadways combine secure, reliable, scalable connectivity with multi-level end-to-end security. They offer fixed, cellular, and wireless options to support remote locations, and enable data collection and processing at the edge. Security is key, and we provide solutions that help protect roadways infrastructure by providing visibility into all connected roadside devices and their security posture, together with network segmentation, and built-in Next-Generation Firewall (NGFW) capabilities, and secure remote access for employees, contractors, and vendors. Operational efficiency can be optimized with centralized management and configuration of industrial devices, and policy management.

To minimize complexity and space requirements, support for ITS visibility, security and data collection capabilities are built into the industrial routers and switches themselves—with no additional hardware required. To provide the resilience required for roadside locations, Cisco's industrial network products provide vibration and shock resistance and are built to withstand extreme temperature and humidity fluctuations.

Learn more about [solutions for connected roadways and intersections](#).

# Connected Roadways and Intersections

## Traffic Management Center

Catalyst Center  
SD-WAN Manager  
Cyber Vision Center  
Secure Equipment Access



Secure remote access, embedded in network devices, to maintain roadside ITS equipment

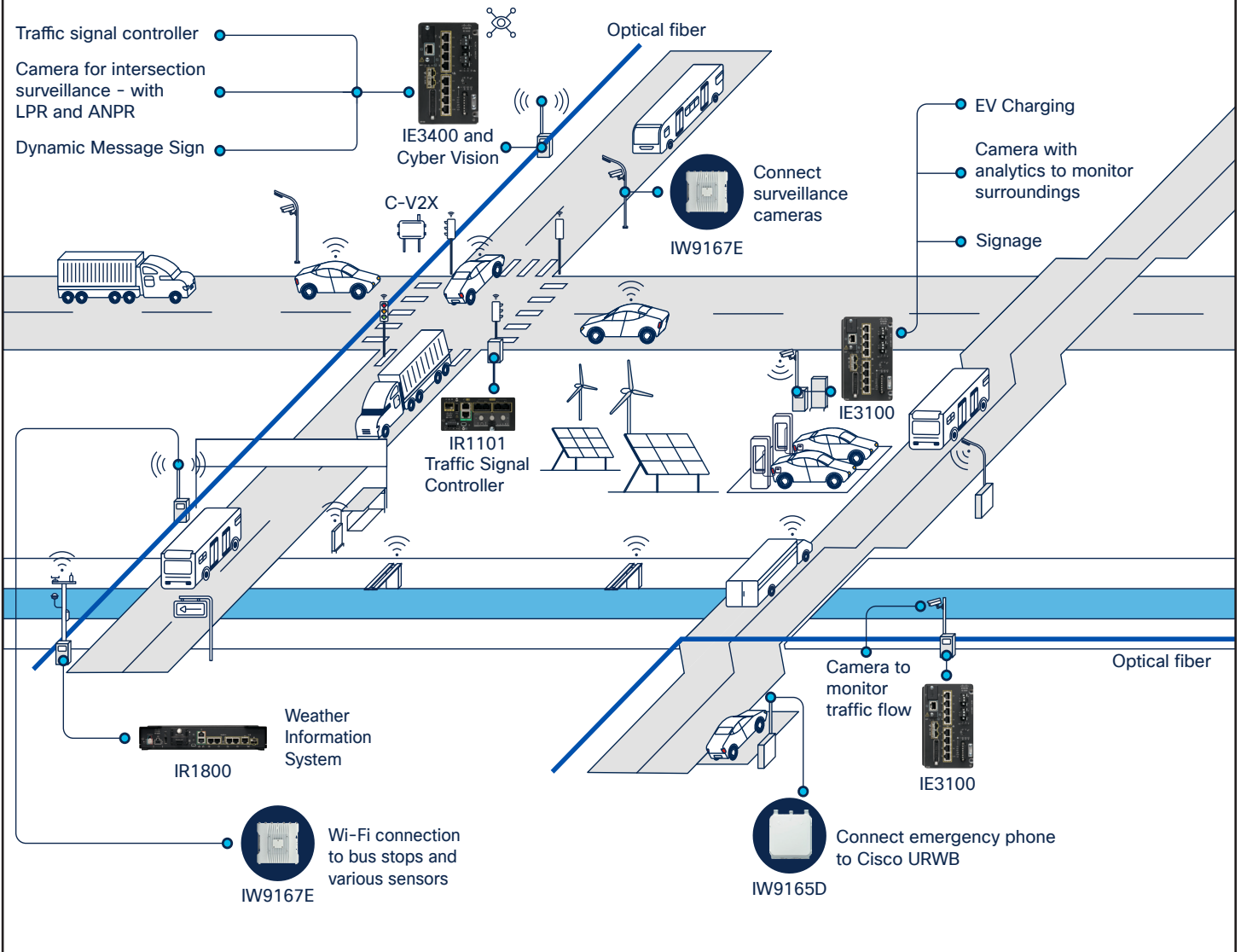

## Connected Intelligent Transportation Systems (ITS)

Connecting ITS equipment at intersections and the roadside is key to reducing accidents and fatalities, reducing congestion, and achieving sustainability goals. It also helps boost operational efficiency and reduce costs. Equipment and systems like traffic signal controllers, surveillance and detection cameras, weather information systems, Wi-Fi access points, and digital signage need to be connected reliably and securely. This enables data from these systems to be leveraged to gain insights to help with process optimization and enhance the flow of traffic.

However, systems can number in the thousands, and fiber may not be available at every location, so cellular or wireless connectivity may also be required. And managing and maintaining everything remotely can be challenging and expensive.

Network devices providing connectivity need to be able to withstand extreme temperature and humidity fluctuations and be compact enough to fit inside roadside cabinets. And the more connected equipment you introduce, the greater the potential cyber risk.

### Challenges

- Lack of availability of connectivity and space at the roadside and at intersections.
- Risk of cyber attacks due to lack of visibility into connected devices and their security posture, limited physical security in roadside locations and lack of control of external access to equipment.
- Outages and delays in troubleshooting and maintenance due to lack of awareness of issues with connected equipment.
- Expensive and time-consuming truck rolls for maintenance and troubleshooting of connected equipment.

### Benefits of Cisco solution

- Scalable, modular fiber, wireless and cellular solutions in compact, ruggedized form factor for connecting systems at the roadside and at intersections.
- Visibility of everything connected to your network, and zero trust remote access, embedded in switches and routers.
- Advanced network security Next Generation Firewall (NGFW) and intrusion protection (IDS/IPS) features to keep roadway assets safe from cyber threats.
- Support for centralized management and configuration of industrial devices in the transportation management center as well as simple and secure provisioning in the field without the need for staging.

# Connecting ITS Equipment

