



# Implementing BGP

Border Gateway Protocol (BGP) is an Exterior Gateway Protocol (EGP) that allows you to create loop-free interdomain routing between autonomous systems. An *autonomous system* is a set of routers under a single technical administration. Routers in an autonomous system can use multiple Interior Gateway Protocols (IGPs) to exchange routing information inside the autonomous system and an EGP to route packets outside the autonomous system.

This module provides conceptual and configuration information on BGP.



---

**Tip** You can programmatically configure BGP and retrieve operational data using `openconfig-network-instance.yang` OpenConfig data model. To get started with using data models, see the .

---

- [Prerequisites for Implementing BGP, on page 3](#)
- [BGP Functional Overview, on page 3](#)
- [Disabling Per Neighbor TCP MSS, on page 136](#)
- [Configuring Discard Extra Paths, on page 138](#)
- [Configuring Per Neighbor TCP MSS, on page 139](#)
- [Disabling Per Neighbor TCP MSS, on page 141](#)
- [Configure BGP Route Filtering by Route Policy, on page 143](#)
- [Configure BGP Attribute Filtering, on page 144](#)
- [Configure BGP Next-Hop Trigger Delay, on page 145](#)
- [Disable Next-Hop Processing on BGP Updates, on page 146](#)
- [Configure BGP Community and Extended-Community Advertisements, on page 148](#)
- [Configure BGP Cost Community, on page 150](#)
- [Configure Software to Store Updates from Neighbor, on page 151](#)
- [BGP Persistence, on page 153](#)
- [Flexible BGP Persistence, on page 155](#)
- [BGP Graceful Maintenance, on page 159](#)
- [Bring Router or Link Back into Service, on page 166](#)
- [Show Command Outputs to Verify BGP Graceful Maintenance, on page 166](#)
- [Bring Router or Link Back into Service, on page 168](#)
- [Show Command Outputs to Verify BGP Graceful Maintenance, on page 168](#)
- [Flow-tag propagation, on page 169](#)
- [Neighbor Capability Suppression, on page 177](#)

- BGP Dynamic Neighbors, on page 179
- Remote AS List, on page 180
- Maximum-peers and Idle-watch timeout, on page 181
- Resetting Neighbors Using BGP Inbound Soft Reset, on page 182
- Resetting Neighbors Using BGP Outbound Soft Reset, on page 183
- Reset Neighbors Using BGP Hard Reset, on page 183
- Clearing Caches, Tables, and Databases, on page 184
- Display System and Network Statistics, on page 185
- Display BGP Process Information, on page 186
- Configure iBGP Multipath Load Sharing , on page 188
- Originate Prefixes with AiGP, on page 189
- Configure BGP Accept Own, on page 191
- Configuring BGP Link-state, on page 193
- Configuring BGP Permanent Network, on page 195
- How to Advertise Permanent Network, on page 196
- Enable BGP Unequal Cost Recursive Load Balancing, on page 198
- Configuring BGP Large Communities, on page 201
- Enabling BGP: Example, on page 206
- Displaying BGP Update Groups: Example, on page 207
- BGP Neighbor Configuration: Example , on page 208
- BGP Confederation: Example , on page 208
- BGP Route Reflector: Example, on page 210
- BGP Route Reflector: Example, on page 210
- BGP MDT Address Family Configuration: Example, on page 211
- BGP Nonstop Routing Configuration: Example, on page 211
- Best-External Path Advertisement Configuration: Example, on page 211
- Primary Backup Path Installation: Example, on page 212
- iBGP Multipath Loadsharing Configuration: Example, on page 212
- Discard Extra Paths Configuration: Example, on page 212
- Verify Per Neighbor TCP MSS: Examples, on page 212
- Originating Prefixes With AiGP: Example, on page 215
- BGP Accept Own Configuration: Example, on page 215
- BGP Unequal Cost Recursive Load Balancing: Example, on page 216
- Flow-tag propagation, on page 218
- Restrictions for Flow-Tag Propagation, on page 219
- Configuring Destination-Based Flow-Tag Propagation, on page 219
- Configure Software to Store Updates from Neighbor, on page 222
- Configuring BGP Route Dampening, on page 223
- Apply Policy When Updating Routing Table, on page 224
- Configure BGP Route Filtering by Route Policy, on page 226
- Configure Destination-based RTBH Filtering , on page 227
- Resilient Hashing and Flow Auto-Recovery, on page 229
- Persistent Loadbalancing , on page 231
- BGP Selective Multipath, on page 232
- Remove and Replace Private AS Numbers from AS Path in BGP, on page 234
- BGP DMZ Link Bandwidth for Unequal Cost Recursive Load Balancing, on page 235

- [BGP Multi-Instance and Multi-AS](#), on page 235
- [BGP Prefix Origin Validation Based on RPKI](#), on page 236
- [BGP Update Message Error Handling](#), on page 238
- [BGP Attribute Filtering](#), on page 239
- [BGP Error Handling and Attribute Filtering Syslog Messages](#), on page 239
- [BGP-RIB Feedback Mechanism for Update Generation](#), on page 240
- [Configure BGP Large Communities](#), on page 240
- [Resetting an eBGP Session Immediately Upon Link Failure](#), on page 245
- [Management Information Base \(MIBs\) for BGP](#), on page 245
- [Virtual Routing Forwarding Next Hop Routing Policy](#), on page 246

## Prerequisites for Implementing BGP

You must be in a user group associated with a task group that includes the proper task IDs. The command reference guides include the task IDs required for each command. If you suspect user group assignment is preventing you from using a command, contact your AAA administrator for assistance.

## BGP Functional Overview

BGP uses TCP as its transport protocol. Two BGP routers form a TCP connection between one another (peer routers) and exchange messages to open and confirm the connection parameters.

BGP routers exchange network reachability information. This information is mainly an indication of the full paths (BGP autonomous system numbers) that a route should take to reach the destination network. This information helps construct a graph that shows which autonomous systems are loop free and where routing policies can be applied to enforce restrictions on routing behavior.

Any two routers forming a TCP connection to exchange BGP routing information are called peers or neighbors. BGP peers initially exchange their full BGP routing tables. After this exchange, incremental updates are sent as the routing table changes. BGP keeps a version number of the BGP table, which is the same for all of its BGP peers. The version number changes whenever BGP updates the table due to routing information changes. Keepalive packets are sent to ensure that the connection is alive between the BGP peers and notification packets are sent in response to error or special conditions.



---

**Note** ASN change for BGP process is not currently supported via **commit replace**.

---

## BGP Router Identifier

For BGP sessions between neighbors to be established, BGP must be assigned a router ID. The router ID is sent to BGP peers in the OPEN message when a BGP session is established.

BGP attempts to obtain a router ID in the following ways (in order of preference):

- By means of the address configured using the **bgp router-id** command in router configuration mode.
- By using the highest IPv4 address on a loopback interface in the system if the router is booted with saved loopback address configuration.

- By using the primary IPv4 address of the first loopback address that gets configured if there are not any in the saved configuration.

If none of these methods for obtaining a router ID succeeds, BGP does not have a router ID and cannot establish any peering sessions with BGP neighbors. In such an instance, an error message is entered in the system log, and the **show bgp summary** command displays a router ID of 0.0.0.0.

After BGP has obtained a router ID, it continues to use it even if a better router ID becomes available. This usage avoids unnecessary flapping for all BGP sessions. However, if the router ID currently in use becomes invalid (because the interface goes down or its configuration is changed), BGP selects a new router ID (using the rules described) and all established peering sessions are reset.



---

**Note** We strongly recommend that the **bgp router-id** command is configured to prevent unnecessary changes to the router ID (and consequent flapping of BGP sessions).

---

## BGP Route Distinguisher

In network design solutions where customer equipment is dual-homed and Fast Reroute is required, such as in EVPN and BGP PIC Edge solutions, the Route Distinguisher (RD) associated with each VRF must be unique per Provider Edge (PE) router. In other design scenarios, while it isn't mandatory for the RD to be unique per PE, it is highly recommended to make it unique. This practice facilitates easier transitions to dual-homed solutions in the future.

There are few available options to keep unique RD per device:

- Manual configuration: You must manually assign a unique value per device in the network. For example, in this scenario:
  - Leaf (ToR) = RD 1
  - Edge DCI Gateway = RD 2
  - Remote PE = RD 3
- Use **rd auto** command under VRF. To assign a unique route distinguisher for each router, you must ensure that each router has a unique BGP router-id. If so, the **rd auto** command assigns a Type 1 route distinguisher to the VRF using the following format: *ip-address:number*. The IP address is specified by the BGP router-id statement and the number (which is derived as an unused index in the 0 to 65535 range) is unique across the VRFs.



---

**Note** In a DCI deployment, for route re-originate with stitching-rt for a particular VRF, using the same Route Distinguisher (RD) between edge DCI gateway and MPLS-VPN PE or same RD between edge DCI gateway and Leaf (ToR) is not supported.

---

## BGP Maximum Prefix - Discard Extra Paths

IOS XR BGP maximum-prefix feature imposes a maximum limit on the number of prefixes that are received from a neighbor for a given address family. Whenever the number of prefixes received exceeds the maximum number configured, the BGP session is terminated, which is the default behavior, after sending a cease notification to the neighbor. The session is down until a manual clear is performed by the user. The session can be resumed by using the **clear bgp** command. It is possible to configure a period after which the session can be automatically brought up by using the **maximum-prefix** command with the **restart** keyword. The maximum prefix limit can be configured by the user. Default limits are used if the user does not configure the maximum number of prefixes for the address family. .

### Discard Extra Paths

An option to discard extra paths is added to the maximum-prefix configuration. Configuring the discard extra paths option drops all excess prefixes received from the neighbor when the prefixes exceed the configured maximum value. This drop does not, however, result in session flap.

The benefits of discard extra paths option are:

- Limits the memory footprint of BGP.
- Stops the flapping of the peer if the paths exceed the set limit.

When the discard extra paths configuration is removed, BGP sends a route-refresh message to the neighbor if it supports the refresh capability; otherwise the session is flapped.

On the same lines, the following describes the actions when the maximum prefix value is changed:

- If the maximum value alone is changed, a route-refresh message is sourced, if applicable.
- If the new maximum value is greater than the current prefix count state, the new prefix states are saved.
- If the new maximum value is less than the current prefix count state, then some existing prefixes are deleted to match the new configured state value.

There is currently no way to control which prefixes are deleted.

### Configure Discard Extra Paths

The discard extra paths option in the maximum-prefix configuration allows you to drop all excess prefixes received from the neighbor when the prefixes exceed the configured maximum value. This drop does not, however, result in session flap.

The benefits of discard extra paths option are:

- Limits the memory footprint of BGP.
- Stops the flapping of the peer if the paths exceed the set limit.

When the discard extra paths configuration is removed, BGP sends a route-refresh message to the neighbor if it supports the refresh capability; otherwise the session is flapped.

**Note**

- When the router drops prefixes, it is inconsistent with the rest of the network, resulting in possible routing loops.
- If prefixes are dropped, the standby and active BGP sessions may drop different prefixes. Consequently, an NSR switchover results in inconsistent BGP tables.
- The discard extra paths configuration cannot co-exist with the *soft reconfig* configuration.
- When the system runs out of physical memory, bgp process exits and you must manually restart bpm. To manually restart, use the **process restart bpm** command.

Perform this task to configure BGP maximum-prefix discard extra paths.

**SUMMARY STEPS**

1. **configure**
2. **router bgp** *as-number*
3. **neighbor** *ip-address*
4. **address-family** { **ipv4** | **ipv6** } **unicast**
5. **maximum-prefix** *maximum* **discard-extra-paths**
6. Use the **commit** or **end** command.

**DETAILED STEPS****Step 1** **configure****Example:**

```
RP/0/# configure
```

Enters .

**Step 2** **router bgp** *as-number***Example:**

```
RP/0/(config)# router bgp 10
```

Specifies the autonomous system number and enters the BGP configuration mode, allowing you to configure the BGP routing process.

**Step 3** **neighbor** *ip-address***Example:**

```
RP/0/(config-bgp)# neighbor 10.0.0.1
```

Places the router in neighbor configuration mode for BGP routing and configures the neighbor IP address as a BGP peer.

**Step 4** **address-family** { **ipv4** | **ipv6** } **unicast****Example:**

```
RP/0/(config-bgp-nbr)# address-family ipv4 unicast
```

Specifies either the IPv4 or IPv6 address family and enters address family configuration submode.

**Step 5** `maximum-prefix` *maximum* `discard-extra-paths`**Example:**

```
RP/0/(config-bgp-nbr-af)# maximum-prefix 1000 discard-extra-paths
```

Configures a limit to the number of prefixes allowed.

Configures discard extra paths to discard extra paths when the maximum prefix limit is exceeded.

**Step 6** Use the `commit` or `end` command.

**commit**—Saves the configuration changes and remains within the configuration session.

**end**—Prompts user to take one of these actions:

- **Yes** — Saves configuration changes and exits the configuration session.
- **No** —Exits the configuration session without committing the configuration changes.
- **Cancel** —Remains in the configuration session, without committing the configuration changes.

**Example**

The following example shows how to configure discard extra paths feature for the IPv4 address family:

```
RP/0//CPU0:router# configure
RP/0//CPU0:router(config)# router bgp 10
RP/0//CPU0:router(config-bgp)# neighbor 10.0.0.1
RP/0//CPU0:router(config-bgp-nbr)# address-family ipv4 unicast
RP/0//CPU0:router(config-bgp-nbr-af)# maximum-prefix 1000 discard-extra-paths
RP/0//CPU0:router(config-bgp-vrf-af)# commit
```

The following screen output shows details about the discard extra paths option:

```
RP/0//CPU0:ios# show bgp neighbor 10.0.0.1

BGP neighbor is 10.0.0.1
Remote AS 10, local AS 10, internal link
Remote router ID 0.0.0.0
BGP state = Idle (No best local address found)
Last read 00:00:00, Last read before reset 00:00:00
Hold time is 180, keepalive interval is 60 seconds
Configured hold time: 180, keepalive: 60, min acceptable hold time: 3
Last write 00:00:00, attempted 0, written 0
Second last write 00:00:00, attempted 0, written 0
Last write before reset 00:00:00, attempted 0, written 0
Second last write before reset 00:00:00, attempted 0, written 0
Last write pulse rcvd not set last full not set pulse count 0
Last write pulse rcvd before reset 00:00:00
Socket not armed for io, not armed for read, not armed for write
Last write thread event before reset 00:00:00, second last 00:00:00
Last KA expiry before reset 00:00:00, second last 00:00:00
Last KA error before reset 00:00:00, KA not sent 00:00:00
Last KA start before reset 00:00:00, second last 00:00:00
Precedence: internet
Multi-protocol capability not received
```





- You can use LDP or Segment Routing (SR) as the transport underlay. You cannot use TE as the transport underlay.
- BGP PIC edge feature is not supported.
- L3VPN and 6VPE over BGP LU feature is not supported.
- BGP PIC core feature is supported.

**Supported features**

The following features are supported:

- BGP LU with inter-AS option C
- 6PE over MPLS transport using LDP or Segment Routing.
- BGP PIC core

**Topology**

*Figure 1: BGP Labeled Unicast (Intra-Autonomous System) Control Plane and Data Plane*

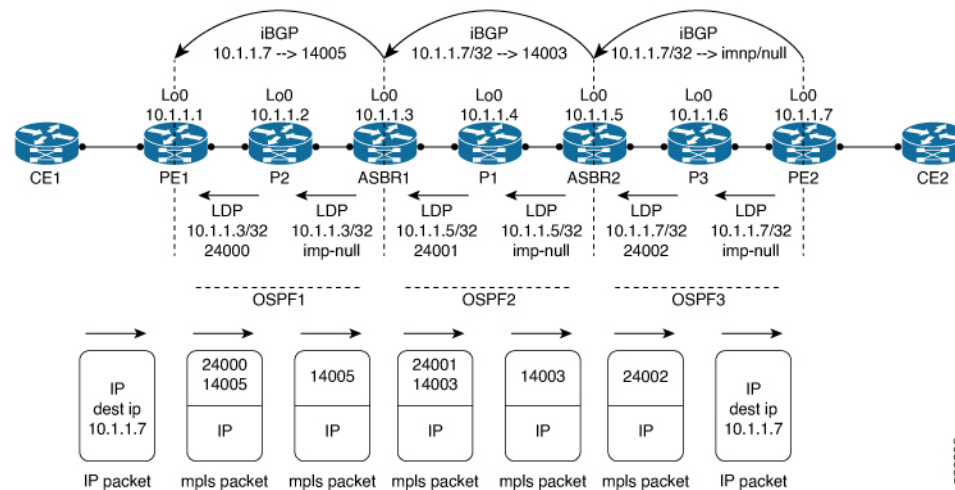

The above diagram explains how PE1 is connected with PE2 through MPLS connectivity. PE1 and PE2 are separated by many areas within the same AS. Consider three network areas OSPF1, OSPF2, and OSPF3. Each of these areas is running separate OSPFs. LDP acts as transport between each of these areas. To establish a connection between the Provider Edge routers PE1 and PE2, send iBGP from PE2 to PE1 through P3, ASBR2, P1 and ASBR1, P2. PE1 must learn the loopback address of PE2 to establish a connection between the loopback address of PE1 and the loopback address of PE2.

The loopback address of PE2 which is 10.1.1.7 advertises a BGP label through iBGP to ASBR2. This address is advertised as an implicit null label. The ASBR2 allocates a local label 14003 for the loopback address 10.1.1.7 and sends it to ASBR1. ASBR1 allocates its own label 14005 to the loopback address 10.1.1.7 and sends it to PE1. PE1 has learnt the prefix of loopback address 10.1.1.7 and the BGP label 14005. The BGP next hop for PE1 is ASBR1. When PE1 sends traffic to PE2, PE1 adds two labels: the BGP-LU label and transport LDP label. The transport LDP label 24000, is above the BGP-LU label 14005. PE1 imposes the transport LDP label and the BGP-LU label when PE1 transmits an IP packet destined to the loopback address 10.1.1.7. The transport LDP label carries the packet to ASBR1. ASBR1 receives the IP packet. It contains

only the BGP-LU label, 14005. ASBR1 swaps the BGP-LU label from 14005 to 14003 and imposes transport LDP label 24001 and sends the IP packet to ASBR2. ASBR2 receives the packet. The BGP-LU label for the loopback address 10.1.1.7 in ASBR2 is implicit null. Only the transport label is pushed to 24002. ASBR2 transmits the transport label that carries the transport to PE2.

Figure 2: BGP Labeled Unicast (Intra-Autonomous System Option C) Control Plane and Data Plane

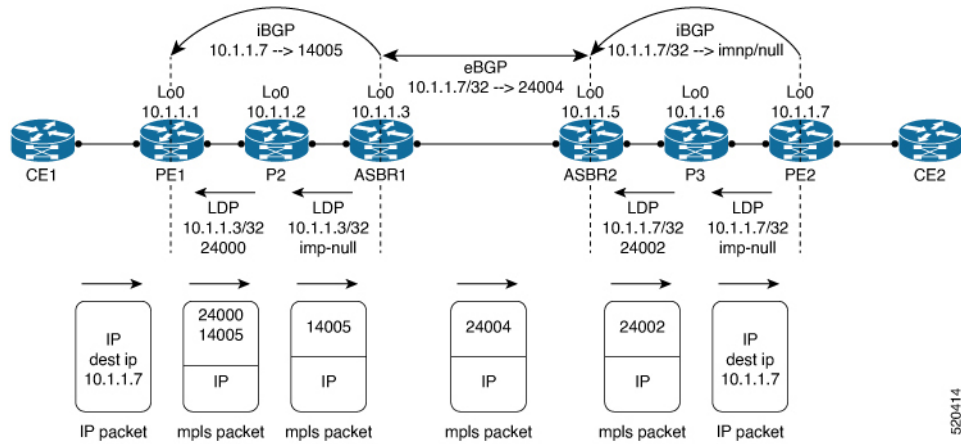

ASBR2 prefers IGP MPLS path over BGP path 10.1.1.7. It advertises LDP local label as BGP label to ASBR1. A LDP swap operation takes place on ASBR2.

The above figure explains how PE1 is connected with PE2 through MPLS connectivity using eBGP. In the above-mentioned scenario, eBGP exists between ASBR1 and ASBR2. PE2 advertises the BGP-LU label which has a value of implicit null to ASBR2 through iBGP. The loopback address is known to ASBR2 through the IGP. ASBR2 prefers the IGP path with ldp label 24002. ASBR2 allocates local label 24004 to loopback 10.1.1.7. It advertises the local label 24004 to ASBR1. ASBR1 creates a local label 14005 and advertises it to PE1. Now, PE1 is aware of the loopback address 10.1.1.7. The IP packet has two labels: the BGP label 14005 and the transport label 24000. PE1 transmits the IP packet to ASBR1. The IP packet received by ASBR1 has only the BGP LU label 14005. ASBR1 swaps BGP-LU label from 14005 to 24004. The IP packet reaches ASBR2 where LDP label 24002 is pushed and transmits the packet to PE2.

Figure 3: 6PE over BGP LU (Inter-AS Option C) Control Plane and Data Plane

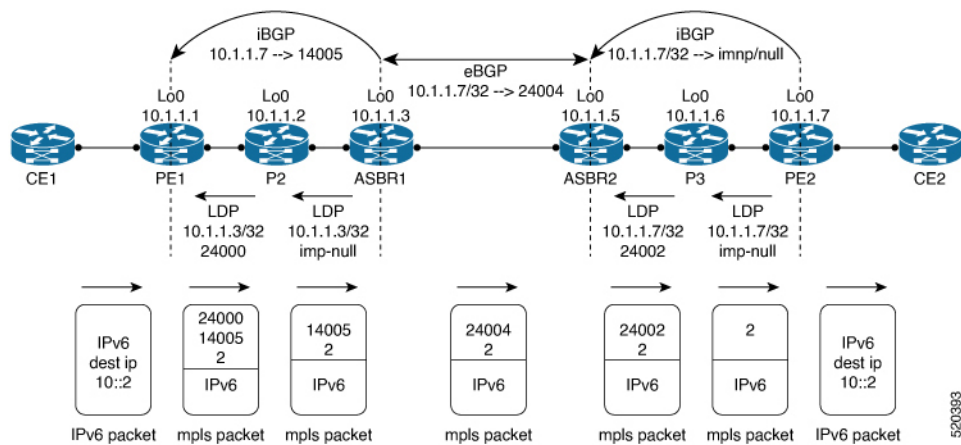

The above illustration explains how PE1 is connected with PE2 through MPLS connectivity using Multihop eBGP between multiple ASes. Multihop BGP exists between PE1 and PE2. PE1 and PE2 can exchange 6PE

routes on the multihop eBGP with the labels. The label value for 6PE is v6 explicit null. When PE2 advertises v6 prefix 10::2/128, the label is always the explicit null label. The BGP label and LDP label constitute the top two labels. The 6PE label constitutes the bottom label which is v6 explicit null. The v6 packet reaches PE1 with destination IP 10:2. The label imposition takes place here. The 6PE label of value 2 is imposed first, the BGP label 14005 is imposed next, and then the next hop LDP label 14005 for the BGP LU next hop is imposed. ASBR1 swaps BGP-LU label from 14005 to 24004 and forwards the packet to ASBR2. ASBR2 adds LDP label on top of 6PE label 2 and forwards it to P3 where LDP label is POPed, so PE2 receives packet with 6PE explicit null label only. PE2 performs a v6 lookup and forwards the packet.

### Configure BGP Labeled Unicast

```
Router(config)# hw-module profile cef bgplu enable
Router(config)# router bgp 1
Router(config-bgp)# bgp router-id 2001:DB8::1
Router(config-bgp)# address-family ipv6 unicast
Router(config-bgp-af)# redistribute connected route-policy set-lbl-idx
Router(config-bgp-af)# allocate-label all
Router(config-bgp-af)# exit
Router(config-bgp)# neighbor 2001:DB8::2
Router(config-bgp)# remote-as 1
Router(config-bgp)# update-source Loopback 0
Router(config-bgp)# address-family ipv6 labeled-unicast
Router(config-bgp)# route-policy pass-all in
Router(config-bgp)# route-policy pass-all out

/* Note: Restart the router for the hw-module command configuration to take effect. */
```

### Running Configuration

```
!
hw-module profile cef bgplu enable
!
router bgp 1
  bgp router-id 2001:DB8::1
  address-family ipv6 unicast
  redistribute connected route-policy set-lbl-idx
  allocate-label all
!
  neighbor 2001:DB8::2
  remote-as 1
  update-source Loopback0
!
  address-family ipv6 labeled-unicast
  route-policy pass-all in
  route-policy pass-all out
!
```

### Verification

SME to provide the show output required below.

```
Router # show bgp ipv6 unicast labels
  Network                Next Hop                Rcvd Label                Local Label

Router# show bgp ipv6 unicast labels
Network                Next Hop                Rcvd Label                Local Label
```

## Convergence for BGP Labeled Unicast PIC Edge

*Table 1: Feature History Table*

Feature Name	Release Information	Feature Description
Convergence for BGP Labeled Unicast PIC Edge	Release 7.7.1	This feature improves the convergence time of BGP labeled unicast (LU) routes to subseconds when an ingress provider edge router fails or loses PE router connectivity, and another PE router needs to be connected. This feature minimizes traffic drops when the primary paths fail for the BGP LU routes.

BGP Labeled Unicast (LU) PIC Edge feature enables you to create and store both the primary and backup path in the Routing Information Base (RIB), Forwarding Information Base (FIB), and Cisco Express Forwarding. When the router detects a failure, the backup or alternate path immediately takes over, thus this feature enables fast failover and convergence in subseconds.

For BGP LU PIC Edge to work, the edge iBGP devices, such as ingress PEs and Autonomous System Border Router (ASBR), must support BGP PIC and must receive backup BGP next hop.

The topology diagram given below illustrates the Convergence for BGP Labeled Unicast PIC Edge feature. The topology is explained as follows:

- The BGP LU PIC Edge feature is enabled on a provider edge router, PE1.
- PE1 learns the BGP LU prefix from the remote PE router, PE2.
- PE1 routes traffic through the Area Border Routers, ABR1, ABR2 and ABR3. If one of them fails, the preprogrammed backup of the failed ABR routes the traffic.
- PE1 routes traffic through the Area Border Routers, ABR1, ABR2 and ABR3.
- PE2 is marked as the backup or alternate next hop and is programmed into the FIB of PE1.
- When PE1 learns PE2 is not reachable through ABR1, it immediately changes the BGP next hop for the PE1's prefix to ABR2.
- The switchover occurs in less than a second regardless of the number of prefixes.
- Subsecond convergence occurs although updates to multiple BGP prefixes are pending.

## Topology

Figure 4: BGP LU PIC Edge

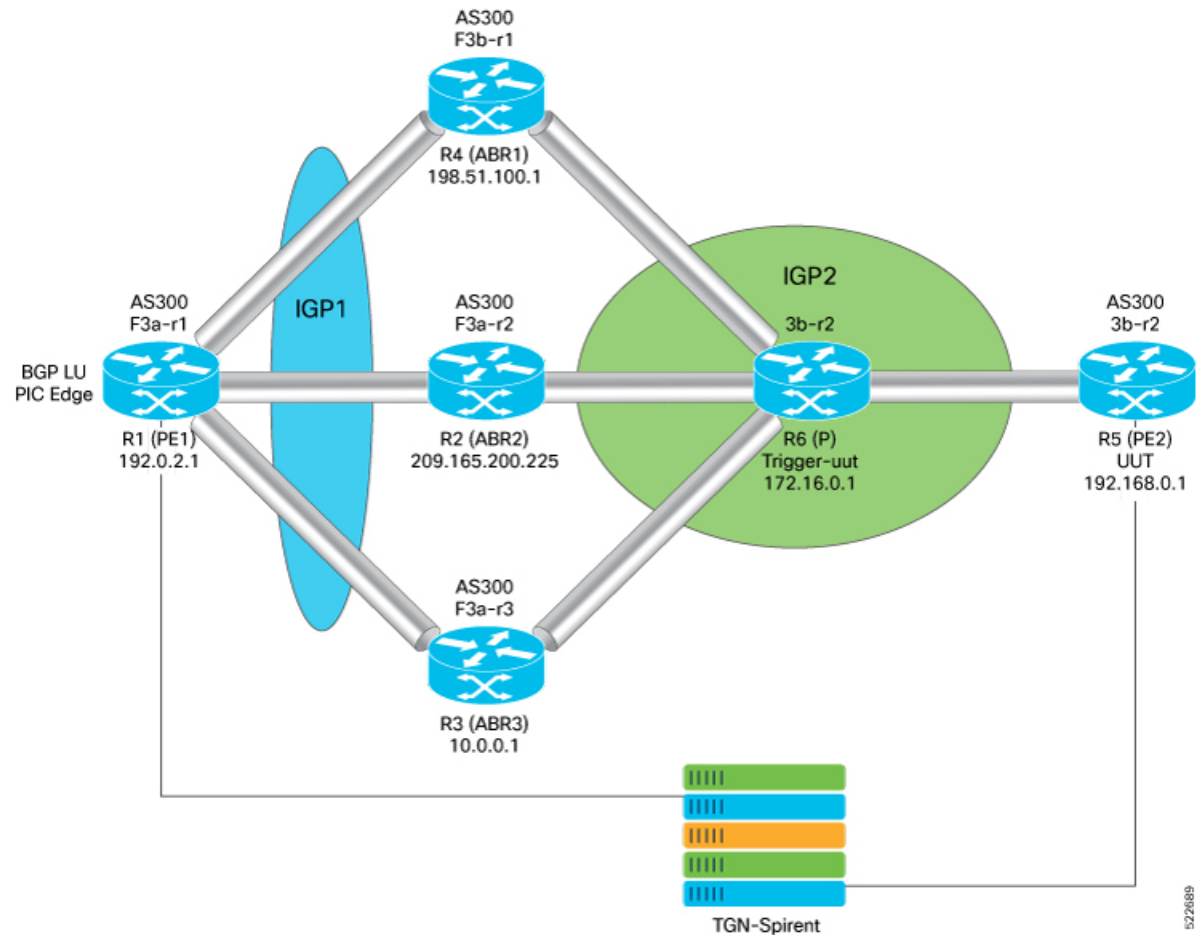

### Guidelines and Limitations

This feature supports BGP multipaths that allows the router to install multiple internal BGP paths and multiple external BGP paths to the forwarding table. The multiple paths enable BGP to load balance traffic across multiple links.

The convergence time is independent of the BGP LU route scale.

### Configure Convergence for BGP Labeled Unicast PIC Edge

Perform the following steps to configure Convergence for BGP Labeled Unicast PIC Edge:

- Configure BGP labeled unicast and attach route-policy to BGP address families.
- Configure BGP labeled unicast multipath and attach route-policy to BGP address families

```
Router(config)# route-policy BGP-PIC-EDGE
Router(config-rpl)# set path-selection backup 1 install
Router(config-rpl)# end-policy
```

```

Router(config)# end
Router(config)# router bgp 200
Router(config-bgp)# bgp router-id 10.0.0.1
Router(config-bgp)# address-family ipv4 unicast
Router(config-bgp-af)# additional-paths receive
Router(config-bgp-af)# additional-paths send
Router(config-bgp-af)# additional-paths selection route-policy BGP-PIC-EDGE

/*Perform the following steps to configure BGP labeled unicast multipath and attach
route-policy to BGP address families: */
Router(config)# route-policy BGP-PIC-EDGE-MULTIPATH
Router(config-rpl)# set path-selection backup 1 install multipath-protect
Router(config)# end-policy
Router(config)# router bgp 200
Router(config)# bgp router-id 192.168.1.0
Router(config)# address-family ipv4 unicast
Router(config)# maximum-paths ibgp 2
Router(config)# additional-paths receive
Router(config)# additional-paths send
Router(config)# additional-paths selection route-policy BGP-PIC-EDGE-MULTIPATH

```

### Running Configuration

```

route-policy BGP-PIC-EDGE
  set path-selection backup 1 install
  end-policy
router bgp 200
  bgp router-id 192.168.1.0
  address-family ipv4 unicast
    additional-paths receive
    additional-paths send
    additional-paths selection route-policy BGP-PIC-EDGE

route-policy BGP-PIC-EDGE-MULTIPATH
  set path-selection backup 1 install multipath-protect
  end-policy
router bgp 200
  bgp router-id 192.168.1.0
  address-family ipv4 unicast
    maximum-paths ibgp 2
    additional-paths receive
    additional-paths send
    additional-paths selection route-policy BGP-PIC-EDGE-MULTIPATH

```

### Verification

Verify that the backup path is established.

```

Router# show cef 192.0.2.1/32
192.168.0.0/32, version 31, internal 0x5000001 0x40 (ptr 0x901d2370) [1], 0x0 (0x90d2beb8),
0xa08 (0x91c74378)
Prefix Len 32, traffic index 0, precedence n/a, priority 4
  via 203.0.113.1/32, 3 dependencies, recursive [flags 0x6000] << Primary Path
    path-idx 0 NHID 0x0 [0x90319650 0x0]
    recursion-via-/32
  next hop 192.51.100.1/32 via 24006/0/21
  next hop 209.165.200.225/32 Hu0/0/0/25 labels imposed {24002 24000}
  next hop 10.0.0.1/32 Hu0/0/0/26 labels imposed {24002 24000}
via 203.0.113.2/32, 2 dependencies, recursive, backup [flags 0x6100] << Backup Path
  path-idx 1 NHID 0x0 [0x903197b8 0x0]
  recursion-via-/32

```

```

next hop 209.165.200.225/32 via 24005/0/21
next hop 192.51.100.1/32 Hu0/0/0/25 labels imposed {24001 24000}
next hop 10.0.0.1/32 Hu0/0/0/26 labels imposed {24001 24000}

```

## Black Box Monitoring

**Table 2: Feature History Table**

Feature Name	Release Information	Feature Description
Black Box Monitoring	Release 7.3.2	This feature enables you to set up forwarding path on the router that you can use to probe customer circuits for system metrics specific to the network devices. Such monitoring helps you to keep up the service level agreements with your customers.

This feature uses a technique whereby a dummy BGP session is established across the GRE encapsulation and decapsulation infrastructure. To terminate the dummy BGP session, the router peers to an address that is configured on the peering fabric which is peering to itself.

The router must peer to an address which is configured on the PF, peering to itself in essence. The only way to make this work is by plugging two interfaces into one another with a physical cable. After two interfaces are connected to one another place one of them into a VRF so that the BGP session is brought up. A router does not attempt to establish a BGP session to itself normally, so you must separate the routing table using a VRF. On the other interface it is a 'normal' interface in the global vrf with the same configuration that is typically on a PF peering interface.

### Configuration Example

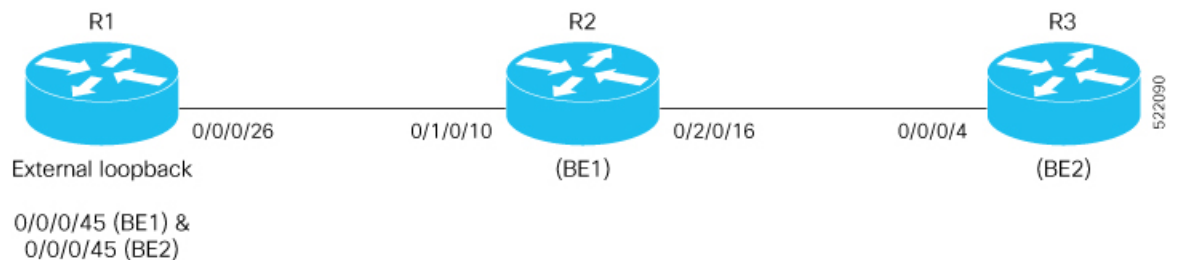

Perform the following steps to configure BGP and GRE tunnel..

```

/* Configure the Local Proxy ARP on the Bundle-Ether interfaces.*/
Router(config)# interface Bundle-Ether1.1
Router(config-if)# ipv4 address 10.1.1.1 255.255.255.240
Router(config-if)# local-proxy-arp
Router(config-if)# encapsulation dot1q 12
Router(config-if)# ipv4 access-group acl-aa ingress

Router(config-if)# exit
Router(config)# interface Bundle-Ether2.1
Router(config-if)# vrf aa
Router(config-if-vrf)# ipv4 address 10.1.1.2 255.255.255.240
Router(config-if-vrf)# local-proxy-arp
Router(config-if-vrf)# encapsulation dot1q 12

/* Configure a bundle on FortyGigE interfaces.*/

```

```

Router(config)# interface FortyGigE 0/0/0/46
Router(config-if)# bundle id 1 mode on
Router(config-if)# exit
Router(config)# interface FortyGigE0/0/0/47
Router(config-if)# bundle id 2 mode on

/* Configure the access list.*/
Router(config-if)# ipv4 access-list acl-aa
Router(config-if)# 1 permit icmp any host 10.1.1.1 echo-reply
Router(config-if)# 2 permit ipv4 any any nexthop1 ipv4 100.100.2.2
Router(config-if)# 10 permit tcp any eq bgp any
Router(config-if)# 20 permit tcp any any eq bgp

/* Configure BGP.*/
Router(config)# router bgp 100
Router(config-bgp)# bgp router-id 10.10.10.10
Router(config-bgp)# bgp log neighbor changes detail
Router(config-bgp)# address-family ipv4 unicast
Router(config-bgp)# maximum-paths ebgp 64
Router(config-bgp)# maximum-paths ibgp 64

/* Apply route policy. */
Router(config)# address-family vpv4 unicast
Router(config-af)# vrf aa
Router(config-af)# rd auto
Router(config-af)# exitexit
Router(config)# address-family ipv4 unicast
Router(config)# exit
Router(config)# neighbor 10.1.1.1
Router(config-nbr)# remote-as 200
Router(config-nbr)# ebgp-multihop 4
Router(config-nbr)# exit
Router(config)# address-family ipv4 unicast
Router(config-af)#send-community-ebgp
Router(config-af)# route-policy pass-all in
Router(config-af)# route-policy pass-all out

/* Configure loopback interfaces. */
Router(config)# interface Loopback1001
Router(config-if)# ipv4 address 10.10.10.10 255.255.255.255
Router(config)# exit
Router(config)# interface Loopback1002
Router(config-if)# vrf aa
Router(config-if-vrf)# ipv4 address 10.10.10.10 255.255.255.255

/* Configure a class map. */
Router(config)# class-map type traffic match-all aa
Router(config-cmap)# match protocol gre
Router(config-cmap)# match destination-address ipv4 10.10.10.10 255.255.255.255
Router(config-cmap)# end-class-map

/* Configure a policy map. */
Router(config)# policy-map type pbr pmap1
Router(config-pmap)# class type traffic aa
Router(config-pmap-c)# decapsulate gre
Router(config-pmap-c)# class type traffic class-default
Router(config-pmap-c)# end-policy-map

/* Configure VRF policy. */
Router(config)# vrf-policy
Router(config-vrf)# vrf default address-family ipv4 policy type pbr input pmap1
Router(config)# interface tunnel-ip 1100
Router(config-if)#ipv4 unnumbered Loopback1001

```



```
Router(config-if)#tunnel mode gre ipv4 encaps
Router(config-if)#tunnel source Loopback1001
Router(config-if)#tunnel destination 200.1.2.1
Router(config-if)#logging events link-status
```

## Running Configuration

```
interface Bundle-Ether1.1
  ipv4 address 10.1.1.1 255.255.255.240
  local-proxy-arp
  encapsulation dot1q 12
  ipv4 access-group aa-acl ingress

interface Bundle-Ether2.1
  vrf aa
  ipv4 address 10.1.1.2 255.255.255.240
  local-proxy-arp
  encapsulation dot1q 12

interface FortyGigE0/0/0/46
  bundle id 1 mode on

interface FortyGigE0/0/0/47
  bundle id 2 mode on
  ipv4 access-list aa-acl
  1 permit icmp any host 10.1.1.1 echo-reply
  2 permit ipv4 any any nexthop1 ipv4 100.100.2.2
  10 permit tcp any eq bgp any
  20 permit tcp any any eq bgp

router bgp 100
  bgp router-id 10.10.10.10
  bgp log neighbor changes detail
  address-family ipv4 unicast
    maximum-paths ebgp 64
    maximum-paths ibgp 64
  !
  address-family vpv4 unicast
  !
  vrf aa
    rd auto
    address-family ipv4 unicast
    !
    neighbor 10.1.1.1
      remote-as 200
      ebgp-multihop 4
    address-family ipv4 unicast
      send-community-ebgp
      route-policy pass-all in
      route-policy pass-all out

interface Loopback1001
  ipv4 address 10.10.10.10 255.255.255.255
RP/0/RP0/CPU0:SF-DD#sh run int loopback 1002
interface Loopback1002
  vrf aa
  ipv4 address 10.10.10.10 255.255.255.255

class-map type traffic match-all aa
  match protocol gre
  match destination-address ipv4 10.10.10.10 255.255.255.255
end-class-map
```

```

policy-map type pbr pmap1
  class type traffic aa
    decapsulate gre
  class type traffic class-default
end-policy-map
!
vrf-policy
  vrf default address-family ipv4 policy type pbr input pmap1

interface tunnel-ip1100
  ipv4 unnumbered Loopback1001
  tunnel mode gre ipv4 encap
  tunnel source Loopback1001
  tunnel destination 200.1.2.1
  logging events link-status

```

## Verification

Verify the configuration of black box monitoring.

```

Router# show bgp vrf aa neighbors
BGP neighbor is 10.1.1.1, vrf aa
  Remote AS 200, local AS 100, external link
  Remote router ID 200.1.2.1
  BGP state = Established, up for 00:12:35
  NSR State: None
  Last read 00:00:30, Last read before reset 00:00:00
  Hold time is 180, keepalive interval is 60 seconds
  Configured hold time: 180, keepalive: 60, min acceptable hold time: 3
  Last write 00:00:30, attempted 19, written 19
  Second last write 00:01:30, attempted 19, written 19
  Last write before reset 00:00:00, attempted 0, written 0
  Second last write before reset 00:00:00, attempted 0, written 0
  Last write pulse rcvd Sep 29 05:50:49.983 last full not set pulse count 30
  Last write pulse rcvd before reset 00:00:00
Connections established 1; dropped 0
  Local host: 10.1.1.2, Local port: 52660, IF Handle: 0x00000000
  Foreign host: 10.1.1.1, Foreign port: 179
  Last reset 00:00:00
  External BGP neighbor may be up to 4 hops away.

```

# BGP Labeled Unicast Version 6

## Overview of BGP Labeled Unicast

The BGP Labeled Unicast (LU) feature, also known as unified MPLS, provides MPLS transport between Provider Edge (PE) routers that are separated by either many IGP boundaries (intra-AS) or by many autonomous systems (inter-AS). Using autonomous systems border routers (ASBRs), you can advertise loopback prefixes of PEs and their MPLS label bindings: iBGP between area border routers (ABRs) and eBGP between autonomous system border routers. You can use Multihop eBGP between the PEs if they are in different autonomous systems (ASes) to exchange the VPN routes. You can run 6PE and other services between the PEs that have BGP LU connectivity.

The BGP LU feature lowers the IGP labeled prefix scale and adjacency scale values. If the router is not being configured with BGP LU, it is necessary to prevent lowering of scale values. Hence it is mandatory to configure

the `hw-module` command before you enable the BGP LU feature. Restart the router for the `hw-module` command configuration to take effect.

The BGP Labeled Unicast Version 6 (BGP LU v6) feature extends the BGP Labeled Unicast (LU) functionality over IPv6.

### Restrictions

- 6VPE over BGP LU feature is not supported.
- Inter-AFI is not supported.
- BGP PIC core feature is not supported.
- Coexistence of 6PE with the same neighbor is not supported.
- Coexistence of BGP LU version 6 IPv6 unicast-address family is not supported.
- VPNV6 over BGP LU v6 is not supported.
- Link-local addresses are not supported.
- Rewrite cases, in which BGP LU is itself the transport, is not supported.
- Carrier Supporting Carrier Version 6 is not supported.
- Inter-AS Option-C with BGP LU Version 6 is not supported.

### Configure BGP Labeled Unicast Version 6

```
Router(config)# hw-module profile cef bgplu enable
Router(config)# router bgp 1
Router(config-bgp)# bgp router-id 2001:DB8::1
Router(config-bgp)# address-family ipv6 unicast
Router(config-bgp-af)# redistribute connected route-policy set-lbl-idx
Router(config-bgp-af)# allocate-label all
Router(config-bgp-af)# exit
Router(config-bgp)# neighbor 2001:DB8::2
Router(config-bgp)# remote-as 1
Router(config-bgp)# update-source Loopback 0
Router(config-bgp)# address-family ipv6 labeled-unicast
Router(config-bgp)# route-policy pass-all in
Router(config-bgp)# route-policy pass-all out
Router(config-bgp)# commit
```



---

**Note** Reload the router for the `hw-module profile cef bgplu enable` command to take effect.

---

### Running Configuration

```
hw-module profile cef bgplu enable
router bgp 1
  bgp router-id 2001:DB8::1
  address-family ipv6 unicast
    redistribute connected route-policy set-lbl-idx
    allocate-label all
  exit
```

```
neighbor 2001:DB8::2
remote-as 1
update-source Loopback 0
address-family ipv6 labeled-unicast
route-policy pass-all in
route-policy pass-all out
```

## Verification

Verify that the BGP LU has been configured.

```
Router# show hw-module profile cef
Thu Jun 17 00:06:32.974 UTC
```

Knob	Status	Applied	Action
<b>BGPLU</b>	<b>Configured</b>	<b>Yes</b>	<b>None</b>
LPTS ACL	Unconfigured	Yes	None
Dark Bandwidth	Unconfigured	Yes	None
MPLS Per Path Stats	Unconfigured	Yes	None
Tunnel TTL Decrement	Unconfigured	Yes	None
High-Scale No-LDP-Over-TE	Unconfigured	Yes	None
IPv6 Hop-limit Punt	Unconfigured	Yes	None
IP Redirect Punt	Unconfigured	Yes	None

Verify the details of route paths along with the BGP and transport label information.

```
Router# show cef ipv6 192:168:9::80/128
Wed Jun 16 07:42:04.789 UTC
192:168:9::80/128, version 27, internal 0x5000001 0x40 (ptr 0x93f2d478) [1], 0x0 (0x93ef6cc0),
0xa08 (0x9460a8a8)
Updated Jun 16 07:36:00.189
Prefix Len 128, traffic index 0, precedence n/a, priority 4, encap-id 0x1001000000001
via 10:0:1::51/128, 3 dependencies, recursive [flags 0x6000]
path-idx 0 NHID 0x0 [0x94720660 0x0]
recursion-via-/128
next hop 10:0:1::51/128 via 16061/0/21
next hop fe80::7af8:c2ff:fee4:20c0/128 Hu0/0/0/27 labels imposed {16061 25001}
/*
16061 - Transport Label
25001 - BGP Label
*/
```

Verify the BGP LU version 6 routes and BGP label information in BGP process.

```
Router# show bgp ipv6 unicast labels
Wed Jun 16 07:34:58.968 UTC
BGP router identifier 10.0.1.50, local AS number 1
BGP generic scan interval 60 secs
Non-stop routing is enabled
BGP table state: Active
Table ID: 0xe0800000 RD version: 6
BGP main routing table version 6
BGP NSR Initial initsync version 3 (Reached)
BGP NSR/ISSU Sync-Group versions 0/0
BGP scan interval 60 secs

Status codes: s suppressed, d damped, h history, * valid, > best
i - internal, r RIB-failure, S stale, N Nexthop-discard
Origin codes: i - IGP, e - EGP, ? - incomplete
Network Next Hop Rcvd Label Local Label
*> 192:168::/64 192:168:1::70 nolabel 24006
*>i192:168:9::80/128 10:0:1::51 25001 nolabel
```

Processed 2 prefixes, 2 paths

## BGP Default Limits

BGP imposes maximum limits on the number of neighbors that can be configured on the router and on the maximum number of prefixes that are accepted from a peer for a given address family. This limitation safeguards the router from resource depletion caused by misconfiguration, either locally or on the remote neighbor. The following limits apply to BGP configurations:

- The default maximum number of peers that can be configured is 4000. The default can be changed using the **bgp maximum neighbor** command. The *limit* range is 1 to 15000. Any attempt to configure additional peers beyond the maximum limit or set the maximum limit to a number that is less than the number of peers currently configured will fail.
- To prevent a peer from flooding BGP with advertisements, a limit is placed on the number of prefixes that are accepted from a peer for each supported address family. The default limits can be overridden through configuration of the maximum-prefix *limit* command for the peer for the appropriate address family. The following default limits are used if the user does not configure the maximum number of prefixes for the address family:
  - IPv4 Unicast: 1048576
  - IPv4 Labeled-unicast: 131072
  - IPv4 Tunnel: 1048576
  - IPv6 Unicast: 524288
  - IPv6 Labeled-unicast: 131072
  - IPv4 Multicast: 131072
  - IPv6 Multicast: 131072
  - IPv4 MVPN: 2097152
  - VPNv4 Unicast: 2097152
  - IPv4 MDT: 131072
  - VPNv6 Unicast: 1048576
  - L2VPN EVPN: 2097152

A cease notification message is sent to the neighbor and the peering with the neighbor is terminated when the number of prefixes received from the peer for a given address family exceeds the maximum limit (either set by default or configured by the user) for that address family.

It is possible that the maximum number of prefixes for a neighbor for a given address family has been configured after the peering with the neighbor has been established and a certain number of prefixes have already been received from the neighbor for that address family. A cease notification message is sent to the neighbor and peering with the neighbor is terminated immediately after the configuration if the configured maximum number of prefixes is fewer than the number of prefixes that have already been received from the neighbor for the address family.

## BGP Next Hop Tracking

BGP receives notifications from the Routing Information Base (RIB) when next-hop information changes (event-driven notifications). BGP obtains next-hop information from the RIB to:

- Determine whether a next hop is reachable.
- Find the fully recursed IGP metric to the next hop (used in the best-path calculation).
- Validate the received next hops.
- Calculate the outgoing next hops.
- Verify the reachability and connectedness of neighbors.

BGP is notified when any of the following events occurs:

- Next hop becomes unreachable
- Next hop becomes reachable
- Fully recursed IGP metric to the next hop changes
- First hop IP address or first hop interface change
- Next hop becomes connected
- Next hop becomes unconnected
- Next hop becomes a local address
- Next hop becomes a nonlocal address



---

**Note** Reachability and recursed metric events trigger a best-path recalculation.

---

Event notifications from the RIB are classified as critical and noncritical. Notifications for critical and noncritical events are sent in separate batches. However, a noncritical event is sent along with the critical events if the noncritical event is pending and there is a request to read the critical events.

- Critical events are related to the reachability (reachable and unreachable), connectivity (connected and unconnected), and locality (local and nonlocal) of the next hops. Notifications for these events are not delayed.
- Noncritical events include only the IGP metric changes. These events are sent at an interval of 3 seconds. A metric change event is batched and sent 3 seconds after the last one was sent.

The next-hop trigger delay for critical and noncritical events can be configured to specify a minimum batching interval for critical and noncritical events using the **nexthop trigger-delay** command. The trigger delay is address family dependent.

The BGP next-hop tracking feature allows you to specify that BGP routes are resolved using only next hops whose routes have the following characteristics:

- To avoid the aggregate routes, the prefix length must be greater than a specified value.

- The source protocol must be from a selected list, ensuring that BGP routes are not used to resolve next hops that could lead to oscillation.

This route policy filtering is possible because RIB identifies the source protocol of route that resolved a next hop as well as the mask length associated with the route. The **nexthop route-policy** command is used to specify the route-policy.

## Next Hop as the IPv6 Address of Peering Interface

BGP can carry IPv6 prefixes over an IPv4 session. The next hop for the IPv6 prefixes can be set through a nexthop policy. In the event that the policy is not configured, the nexthops are set as the IPv6 address of the peering interface (IPv6 neighbor interface or IPv6 update source interface, if any one of the interfaces is configured).

If the nexthop policy is not configured and neither the IPv6 neighbor interface nor the IPv6 update source interface is configured, the next hop is the IPv4 mapped IPv6 address.

### IPv6 Multiprotocol BGP Peering Using a Global Address

When all ECMP links are shutdown except any one of the interfaces, the next-hop is changed from global address to link-local address which leads to traffic loss of all flows for a few seconds transient time.

You can then configure the **set next-hop ipv6-global** command under the BGP table-policy to avoid traffic loss over an undisturbed path.

BGP installs global ipv6 address nexthop for multipath routes and install *linklocal* and *ifhandle* for single path route to connect *ebgp neighbor* directly. You can configure the **set next-hop ipv6-global** command under the BGP table-policy as follows to set the global ipv6 address nexthop:

```
route-policy RESILIENT-HASH-V6
  if destination in (1000:1000::/32 le 128) or destination in (2000:1000::/32 le 128) then
    set load-balance ecmp-consistent
    set next-hop ipv6-global
  pass
endif
pass
end-policy
```

## Scoped IPv4 Table Walk

To determine which address family to process, a next-hop notification is received by first de-referencing the gateway context associated with the next hop, then looking into the gateway context to determine which address families are using the gateway context. The IPv4 unicast address families share the same gateway context, because they are registered with the IPv4 unicast table in the RIB. As a result, the global IPv4 unicast table processed when an IPv4 unicast next-hop notification is received from the RIB. A mask is maintained in the next hop, indicating the next hop belongs to IPv4 unicast. This scoped table walk localizes the processing in the appropriate address family table.

## Reordered Address Family Processing

The software walks address family tables based on the numeric value of the address family. When a next-hop notification batch is received, the order of address family processing is reordered to the following order:

- IPv4 tunnel
- VPNv4 unicast

- IPv4 labeled unicast
- IPv4 unicast
- IPv4 multicast
- IPv6 unicast

## New Thread for Next-Hop Processing

The critical-event thread in the spkr process handles only next-hop, Bidirectional Forwarding Detection (BFD), and fast-external-failover (FEF) notifications. This critical-event thread ensures that BGP convergence is not adversely impacted by other events that may take a significant amount of time.

## show, clear, and debug Commands

The **show bgp nexthops** command provides statistical information about next-hop notifications, the amount of time spent in processing those notifications, and details about each next hop registered with the RIB. The **clear bgp nexthop performance-statistics** command ensures that the cumulative statistics associated with the processing part of the next-hop **show** command can be cleared to help in monitoring. The **clear bgp nexthop registration** command performs an asynchronous registration of the next hop with the RIB.

The **debug bgp nexthop** command displays information on next-hop processing. The **out** keyword provides debug information only about BGP registration of next hops with RIB. The **in** keyword displays debug information about next-hop notifications received from RIB. The **out** keyword displays debug information about next-hop notifications sent to the RIB.

## BGP Configuration

BGP in Cisco IOS XR software follows a neighbor-based configuration model that requires that all configurations for a particular neighbor be grouped in one place under the neighbor configuration. Peer groups are not supported for either sharing configuration between neighbors or for sharing update messages. The concept of peer group has been replaced by a set of configuration groups to be used as templates in BGP configuration and automatically generated update groups to share update messages between neighbors.

### Configuration Modes

BGP configurations are grouped into modes. The following sections show how to enter some of the BGP configuration modes. From a mode, you can enter the **?** command to display the commands available in that mode.

#### *Router Configuration Mode*

The following example shows how to enter router configuration mode:

```
Router# configuration
Router(config)# router bgp 140
Router(config-bgp)#
```

#### *Router Address Family Configuration Mode*

The following example shows how to enter router address family configuration mode:

```
Router(config)# router bgp 112
```



```
Router(config-bgp) # address-family ipv4 unicast
Router(config-bgp-af) #
```

### *Neighbor Configuration Mode*

The following example shows how to enter neighbor configuration mode:

```
Router(config) # router bgp 140
Router(config-bgp) # neighbor 10.0.0.1
Router(config-bgp-nbr) #
```

### *VRF Configuration Mode*

The following example shows how to enter VPN routing and forwarding (VRF) configuration mode:

```
Router(config) # router bgp 140
Router(config-bgp) # vrf vrf_A
Router(config-bgp-vrf) #
```

### *VRF Neighbor Configuration Mode*

The following example shows how to enter VRF neighbor configuration mode:

```
Router(config) # router bgp 140
Router(config-bgp) # vrf vrf_A
Router(config-bgp-vrf) # neighbor 11.0.1.2
Router(config-bgp-vrf-nbr) #
```

### *VRF Neighbor Address Family Configuration Mode*

The following example shows how to enter VRF neighbor address family configuration mode:

```
RP/0/(config) # router bgp 112
RP/0/(config-bgp) # vrf vrf_A
RP/0/(config-bgp-vrf) # neighbor 11.0.1.2
RP/0/(config-bgp-vrf-nbr) # address-family ipv4 unicast
RP/0/(config-bgp-vrf-nbr-af) #
```

### *VPNv6 Address Family Configuration Mode*

The following example shows how to enter VPNv6 address family configuration mode:

```
Router(config) # router bgp 150
Router(config-bgp) # address-family vpnv6 unicast
Router(config-bgp-af) #
```

### *L2VPN Address Family Configuration Mode*

The following example shows how to enter L2VPN address family configuration mode:

```
Router(config) # router bgp 100
Router(config-bgp) # address-family l2vpn vpls-vpws
```

```
Router(config-bgp-af) #
```

## Neighbor Submode

Cisco IOS XR BGP uses a neighbor submode to make it possible to enter configurations without having to prefix every configuration with the **neighbor** keyword and the neighbor address:

- Cisco IOS XR software has a submode available for neighbors in which it is not necessary for every command to have a “neighbor x.x.x.x” prefix:

In Cisco IOS XR software, the configuration is as follows:

```
Router(config-bgp) # neighbor 192.23.1.2
Router(config-bgp-nbr) # remote-as 2002
Router(config-bgp-nbr) # address-family ipv4 unicast
```

- An address family configuration submode inside the neighbor configuration submode is available for entering address family-specific neighbor configurations. In the Cisco IOS XR software, the configuration is as follows:

```
Router(config-bgp) # neighbor 2002::2
Router(config-bgp-nbr) # remote-as 2023
Router(config-bgp-nbr) # address-family ipv6 unicast
Router(config-bgp-nbr-af) # next-hop-self
Router(config-bgp-nbr-af) # route-policy one in
```

## Configuration Templates

The **af-group**, **session-group**, and **neighbor-group** configuration commands provide template support for the neighbor configuration in Cisco IOS XR software.

The **af-group** command is used to group address family-specific neighbor commands within an IPv4, IPv6, address family. Neighbors that have the same address family configuration are able to use the address family group (af-group) name for their address family-specific configuration. A neighbor inherits the configuration from an address family group by way of the **use** command. If a neighbor is configured to use an address family group, the neighbor (by default) inherits the entire configuration from the address family group. However, a neighbor does not inherit all of the configuration from the address family group if items are explicitly configured for the neighbor. The address family group configuration is entered under the BGP router configuration mode. The following example shows how to enter address family group configuration mode

```
Router(config) # router bgp 140
Router(config-bgp) # af-group afmcast1 address-family ipv4 unicast
Router(config-bgp-afgrp) #
```

The **session-group** command allows you to create a session group from which neighbors can inherit address family-independent configuration. A neighbor inherits the configuration from a session group by way of the **use** command. If a neighbor is configured to use a session group, the neighbor (by default) inherits the entire configuration of the session group. A neighbor does not inherit all of the configuration from a session group if a configuration is done directly on that neighbor. The following example shows how to enter session group configuration mode:

```
Router# router bgp 140
Router(config-bgp) # session-group session1
Router(config-bgp-sngrp) #
```

The **neighbor-group** command helps you apply the same configuration to one or more neighbors. Neighbor groups can include session groups and address family groups and can comprise the complete configuration for a neighbor. After a neighbor group is configured, a neighbor can inherit the configuration of the group using the **use** command. If a neighbor is configured to use a neighbor group, the neighbor inherits the entire BGP configuration of the neighbor group.

The following example shows how to enter neighbor group configuration mode:

```
Router(config) # router bgp 123
Router(config-bgp) # neighbor-group nbrgroup1
Router(config-bgp-nbrgrp) #
```

The following example shows how to enter neighbor group address family configuration mode:

```
Router(config) # router bgp 140
Router(config-bgp) # neighbor-group nbrgroup1
Router(config-bgp-nbrgrp) # address-family ipv4 unicast
Router(config-bgp-nbrgrp-af) #
```

- However, a neighbor does not inherit all of the configuration from the neighbor group if items are explicitly configured for the neighbor. In addition, some part of the configuration of the neighbor group could be hidden if a session group or address family group was also being used.

Configuration grouping has the following effects in Cisco IOS XR software:

- Commands entered at the session group level define address family-independent commands (the same commands as in the neighbor submode).
- Commands entered at the address family group level define address family-dependent commands for a specified address family (the same commands as in the neighbor-address family configuration submode).
- Commands entered at the neighbor group level define address family-independent commands and address family-dependent commands for each address family (the same as all available **neighbor** commands), and define the **use** command for the address family group and session group commands.

## Template Inheritance Rules

In Cisco IOS XR software, BGP neighbors or groups inherit configuration from other configuration groups.

For address family-independent configurations:

- Neighbors can inherit from session groups and neighbor groups.
- Neighbor groups can inherit from session groups and other neighbor groups.
- Session groups can inherit from other session groups.
- If a neighbor uses a session group and a neighbor group, the configurations in the session group are preferred over the global address family configurations in the neighbor group.

For address family-dependent configurations:

- Address family groups can inherit from other address family groups.
- Neighbor groups can inherit from address family groups and other neighbor groups.
- Neighbors can inherit from address family groups and neighbor groups.

Configuration group inheritance rules are numbered in order of precedence as follows:

1. If the item is configured directly on the neighbor, that value is used. In the example that follows, the advertisement interval is configured both on the neighbor group and neighbor configuration and the advertisement interval being used is from the neighbor configuration:

```
Router(config)# router bgp 140
Router(config-bgp)# neighbor-group AS_1
Router(config-bgp-nbrgrp)# advertisement-interval 15
Router(config-bgp-nbrgrp)# exit
Router(config-bgp)# neighbor 10.1.1.1
Router(config-bgp-nbr)# remote-as 1
Router(config-bgp-nbr)# use neighbor-group AS_1
Router(config-bgp-nbr)# advertisement-interval 20
```

The following output from the **show bgp neighbors** command shows that the advertisement interval used is 20 seconds:

```
Router# show bgp neighbors 10.1.1.1

BGP neighbor is 10.1.1.1, remote AS 1, local AS 140, external link
Remote router ID 0.0.0.0
  BGP state = Idle
  Last read 00:00:00, hold time is 180, keepalive interval is 60 seconds
  Received 0 messages, 0 notifications, 0 in queue
  Sent 0 messages, 0 notifications, 0 in queue
  Minimum time between advertisement runs is 20 seconds

For Address Family: IPv4 Unicast
BGP neighbor version 0
Update group: 0.1
eBGP neighbor with no inbound or outbound policy; defaults to 'drop'
Route refresh request: received 0, sent 0
0 accepted prefixes
Prefix advertised 0, suppressed 0, withdrawn 0, maximum limit 524288
Threshold for warning message 75%

Connections established 0; dropped 0
Last reset 00:00:14, due to BGP neighbor initialized
External BGP neighbor not directly connected.
```

2. Otherwise, if an item is configured to be inherited from a session-group or neighbor-group and on the neighbor directly, then the configuration on the neighbor is used. If a neighbor is configured to be inherited from session-group or af-group, but no directly configured value, then the value in the session-group or af-group is used. In the example that follows, the advertisement interval is configured on a neighbor group and a session group and the advertisement interval value being used is from the session group:

```
Router(config)# router bgp 140
Router(config-bgp)# session-group AS_2
Router(config-bgp-sngrp)# advertisement-interval 15
```

```

Router(config-bgp-sngrp)# exit
Router(config-bgp)# neighbor-group AS_1
Router(config-bgp-nbrgrp)# advertisement-interval 20
Router(config-bgp-nbrgrp)# exit
Router(config-bgp)# neighbor 192.168.0.1
Router(config-bgp-nbr)# remote-as 1
Router(config-bgp-nbr)# use session-group AS_2
Router(config-bgp-nbr)# use neighbor-group AS_1

```

The following output from the **show bgp neighbors** command shows that the advertisement interval used is 15 seconds:

```

Router# show bgp neighbors 192.168.0.1

BGP neighbor is 192.168.0.1, remote AS 1, local AS 140, external link
Remote router ID 0.0.0.0
  BGP state = Idle
  Last read 00:00:00, hold time is 180, keepalive interval is 60 seconds
  Received 0 messages, 0 notifications, 0 in queue
  Sent 0 messages, 0 notifications, 0 in queue
  Minimum time between advertisement runs is 15 seconds

For Address Family: IPv4 Unicast
  BGP neighbor version 0
  Update group: 0.1
  eBGP neighbor with no inbound or outbound policy; defaults to 'drop'
  Route refresh request: received 0, sent 0
  0 accepted prefixes
  Prefix advertised 0, suppressed 0, withdrawn 0, maximum limit 524288
  Threshold for warning message 75%

Connections established 0; dropped 0
Last reset 00:03:23, due to BGP neighbor initialized
External BGP neighbor not directly connected.

```

3. Otherwise, if the neighbor uses a neighbor group and does not use a session group or address family group, the configuration value can be obtained from the neighbor group either directly or through inheritance. In the example that follows, the advertisement interval from the neighbor group is used because it is not configured directly on the neighbor and no session group is used:

```

Router(config)# router bgp 150
Router(config-bgp)# session-group AS_2
Router(config-bgp-sngrp)# advertisement-interval 20
Router(config-bgp-sngrp)# exit
Router(config-bgp)# neighbor-group AS_1
Router(config-bgp-nbrgrp)# advertisement-interval 15
Router(config-bgp-nbrgrp)# exit
Router(config-bgp)# neighbor 192.168.1.1
Router(config-bgp-nbr)# remote-as 1
Router(config-bgp-nbr)# use neighbor-group AS_1

```

The following output from the **show bgp neighbors** command shows that the advertisement interval used is 15 seconds:

```

Router# show bgp neighbors 192.168.1.1

BGP neighbor is 192.168.2.2, remote AS 1, local AS 140, external link
Remote router ID 0.0.0.0
  BGP state = Idle

```

```

Last read 00:00:00, hold time is 180, keepalive interval is 60 seconds
Received 0 messages, 0 notifications, 0 in queue
Sent 0 messages, 0 notifications, 0 in queue
Minimum time between advertisement runs is 15 seconds

```

```

For Address Family: IPv4 Unicast
BGP neighbor version 0
Update group: 0.1
eBGP neighbor with no outbound policy; defaults to 'drop'
Route refresh request: received 0, sent 0
Inbound path policy configured
Policy for incoming advertisements is POLICY_1
0 accepted prefixes
Prefix advertised 0, suppressed 0, withdrawn 0, maximum limit 524288
Threshold for warning message 75%

```

```

Connections established 0; dropped 0
Last reset 00:01:14, due to BGP neighbor initialized
External BGP neighbor not directly connected.

```

To illustrate the same rule, the following example shows how to set the advertisement interval to 15 (from the session group) and 25 (from the neighbor group). The advertisement interval set in the session group overrides the one set in the neighbor group. The inbound policy is set to POLICY\_1 from the neighbor group.

```

Routerconfig)# router bgp 140
Router(config-bgp)# session-group ADV
Router(config-bgp-sngrp)# advertisement-interval 15
Router(config-bgp-sngrp)# exit
Router(config-bgp)# neighbor-group ADV_2
Router(config-bgp-nbrgrp)# advertisement-interval 25
Router(config-bgp-nbrgrp)# address-family ipv4 unicast
Router(config-bgp-nbrgrp-af)# route-policy POLICY_1 in
Router(config-bgp-nbrgrp-af)# exit
Router(config-bgp-nbrgrp)# exit
Router(config-bgp)# exit
Router(config-bgp)# neighbor 192.168.2.2
Router(config-bgp-nbr)# remote-as 1
Router(config-bgp-nbr)# use session-group ADV
Router(config-bgp-nbr)# use neighbor-group ADV_2

```

The following output from the **show bgp neighbors** command shows that the advertisement interval used is 15 seconds:

```

Router# show bgp neighbors 192.168.2.2

BGP neighbor is 192.168.2.2, remote AS 1, local AS 140, external link
Remote router ID 0.0.0.0
BGP state = Idle
Last read 00:00:00, hold time is 180, keepalive interval is 60 seconds
Received 0 messages, 0 notifications, 0 in queue
Sent 0 messages, 0 notifications, 0 in queue
Minimum time between advertisement runs is 15 seconds

For Address Family: IPv4 Unicast
BGP neighbor version 0
Update group: 0.1
eBGP neighbor with no inbound or outbound policy; defaults to 'drop'
Route refresh request: received 0, sent 0
0 accepted prefixes

```

```
Prefix advertised 0, suppressed 0, withdrawn 0, maximum limit 524288
Threshold for warning message 75%
```

```
Connections established 0; dropped 0
Last reset 00:02:03, due to BGP neighbor initialized
External BGP neighbor not directly connected.
```

4. Otherwise, the default value is used. In the example that follows, neighbor 10.0.101.5 has the minimum time between advertisement runs set to 30 seconds (default) because the neighbor is not configured to use the neighbor configuration or the neighbor group configuration:

```
Router(config)# router bgp 140
Router(config-bgp)# neighbor-group AS_1
Router(config-bgp-nbrgrp)# remote-as 1
Router(config-bgp-nbrgrp)# exit
Router(config-bgp)# neighbor-group adv_15
Router(config-bgp-nbrgrp)# remote-as 10
Router(config-bgp-nbrgrp)# advertisement-interval 15
Router(config-bgp-nbrgrp)# exit
Router(config-bgp)# neighbor 10.0.101.5
Router(config-bgp-nbr)# use neighbor-group AS_1
Router(config-bgp-nbr)# exit
Router(config-bgp)# neighbor 10.0.101.10
Router(config-bgp-nbr)# use neighbor-group adv_15
```

The following output from the **show bgp neighbors** command shows that the advertisement interval used is 30 seconds:

```
Router# show bgp neighbors 10.0.101.5

BGP neighbor is 10.0.101.5, remote AS 1, local AS 140, external link
Remote router ID 0.0.0.0
  BGP state = Idle
  Last read 00:00:00, hold time is 180, keepalive interval is 60 seconds
  Received 0 messages, 0 notifications, 0 in queue
  Sent 0 messages, 0 notifications, 0 in queue
  Minimum time between advertisement runs is 30 seconds

For Address Family: IPv4 Unicast
  BGP neighbor version 0
  Update group: 0.2
  eBGP neighbor with no inbound or outbound policy; defaults to 'drop'
  Route refresh request: received 0, sent 0
  0 accepted prefixes
  Prefix advertised 0, suppressed 0, withdrawn 0, maximum limit 524288
  Threshold for warning message 75%
  Connections established 0; dropped 0
  Last reset 00:00:25, due to BGP neighbor initialized
  External BGP neighbor not directly connected.
```

The inheritance rules used when groups are inheriting configuration from other groups are the same as the rules given for neighbors inheriting from groups.

## Viewing Inherited Configurations

You can use the following **show** commands to view BGP inherited configurations:

**show bgp neighbors**

Use the **show bgp neighbors** command to display information about the BGP configuration for neighbors.

- Use the **configuration** keyword to display the effective configuration for the neighbor, including any settings that have been inherited from session groups, neighbor groups, or address family groups used by this neighbor.
- Use the **inheritance** keyword to display the session groups, neighbor groups, and address family groups from which this neighbor is capable of inheriting configuration.

The **show bgp neighbors** command examples that follow are based on this sample configuration:

```
Router(config)# router bgp 142
Router(config-bgp)# af-group GROUP_3 address-family ipv4 unicast
Router(config-bgp-afgrp)# next-hop-self
Router(config-bgp-afgrp)# route-policy POLICY_1 in
Router(config-bgp-afgrp)# exit
Router(config-bgp)# session-group GROUP_2
Router(config-bgp-sngrp)# advertisement-interval 15
Router(config-bgp-sngrp)# exit
Router(config-bgp)# neighbor-group GROUP_1
Router(config-bgp-nbrgrp)# use session-group GROUP_2
Router(config-bgp-nbrgrp)# ebgp-multihop 3
Router(config-bgp-nbrgrp)# address-family ipv4 unicast
Router(config-bgp-nbrgrp-af)# weight 100
Router(config-bgp-nbrgrp-af)# send-community-ebgp
Router(config-bgp-nbrgrp-af)# exit
Router(config-bgp-nbrgrp)# exit
Router(config-bgp)# neighbor 192.168.0.1
Router(config-bgp-nbr)# remote-as 2
Router(config-bgp-nbr)# use neighbor-group GROUP_1
Router(config-bgp-nbr)# address-family ipv4 unicast
Router(config-bgp-nbr-af)# use af-group GROUP_3
Router(config-bgp-nbr-af)# weight 200
```

**show bgp neighbors**

Use the **show bgp neighbors** command to display information about the BGP configuration for neighbors.

- Use the **configuration** keyword to display the effective configuration for the neighbor, including any settings that have been inherited from session groups, neighbor groups, or address family groups used by this neighbor.
- Use the **inheritance** keyword to display the session groups, neighbor groups, and address family groups from which this neighbor is capable of inheriting configuration.

The **show bgp neighbors** command examples that follow are based on this sample configuration:

```
Router(config)# router bgp 142
Router(config-bgp)# af-group GROUP_3 address-family ipv4 unicast
Router(config-bgp-afgrp)# next-hop-self
Router(config-bgp-afgrp)# route-policy POLICY_1 in
Router(config-bgp-afgrp)# exit
Router(config-bgp)# session-group GROUP_2
Router(config-bgp-sngrp)# advertisement-interval 15
Router(config-bgp-sngrp)# exit
Router(config-bgp)# neighbor-group GROUP_1
```



```

Router(config-bgp-nbrgrp) # use session-group GROUP_2
Router(config-bgp-nbrgrp) # ebgp-multihop 3
Router(config-bgp-nbrgrp) # address-family ipv4 unicast
Router(config-bgp-nbrgrp-af) # weight 100
Router(config-bgp-nbrgrp-af) # send-community-ebgp
Router(config-bgp-nbrgrp-af) # exit
Router(config-bgp-nbrgrp) # exit
Router(config-bgp) # neighbor 192.168.0.1
Router(config-bgp-nbr) # remote-as 2
Router(config-bgp-nbr) # use neighbor-group GROUP_1
Router(config-bgp-nbr) # address-family ipv4 unicast
Router(config-bgp-nbr-af) # use af-group GROUP_3
Router(config-bgp-nbr-af) # weight 200

```

## show bgp af-group

Use the **show bgp af-group** command to display address family groups:

- Use the **configuration** keyword to display the effective configuration for the address family group, including any settings that have been inherited from address family groups used by this address family group.
- Use the **inheritance** keyword to display the address family groups from which this address family group is capable of inheriting configuration.
- Use the **users** keyword to display the neighbors, neighbor groups, and address family groups that inherit configuration from this address family group.

The **show bgp af-group** sample commands that follow are based on this sample configuration:

```

Router(config) # router bgp 140
Router(config-bgp) # af-group GROUP_3 address-family ipv4 unicast
Router(config-bgp-afgrp) # remove-private-as
Router(config-bgp-afgrp) # route-policy POLICY_1 in
Router(config-bgp-afgrp) # exit
Router(config-bgp) # af-group GROUP_1 address-family ipv4 unicast
Router(config-bgp-afgrp) # use af-group GROUP_2
Router(config-bgp-afgrp) # maximum-prefix 2500 75 warning-only
Router(config-bgp-afgrp) # default-originate
Router(config-bgp-afgrp) # exit
Router(config-bgp) # af-group GROUP_2 address-family ipv4 unicast
Router(config-bgp-afgrp) # use af-group GROUP_3
Router(config-bgp-afgrp) # send-community-ebgp
Router(config-bgp-afgrp) # send-extended-community-ebgp
Router(config-bgp-afgrp) # capability orf prefix both

```

The following example displays sample output from the **show bgp af-group** command using the **configuration** keyword. This example shows from where each configuration item was inherited. The **default-originate** command was configured directly on this address family group (indicated by [ ]). The **remove-private-as** command was inherited from address family group GROUP\_2, which in turn inherited from address family group GROUP\_3:

```

Router# show bgp af-group GROUP_1 configuration

af-group GROUP_1 address-family ipv4 unicast
  capability orf prefix-list both           [a:GROUP_2]
  default-originate                         [ ]

```

**show bgp session-group**

```

maximum-prefix 2500 75 warning-only      []
route-policy POLICY_1 in                  [a:GROUP_2 a:GROUP_3]
remove-private-AS                          [a:GROUP_2 a:GROUP_3]
send-community-ebgp                         [a:GROUP_2]
send-extended-community-ebgp               [a:GROUP_2]

```

The following example displays sample output from the **show bgp af-group** command using the **users** keyword:

```

Router# show bgp af-group GROUP_2 users

IPv4 Unicast: a:GROUP_1

```

The following example displays sample output from the **show bgp af-group** command using the **inheritance** keyword. This shows that the specified address family group GROUP\_1 directly uses the GROUP\_2 address family group, which in turn uses the GROUP\_3 address family group:

```

Router# show bgp af-group GROUP_1 inheritance

IPv4 Unicast: a:GROUP_2 a:GROUP_3

```

**show bgp session-group**

Use the **show bgp session-group** command to display session groups:

- Use the **configuration** keyword to display the effective configuration for the session group, including any settings that have been inherited from session groups used by this session group.
- Use the **inheritance** keyword to display the session groups from which this session group is capable of inheriting configuration.
- Use the **users** keyword to display the session groups, neighbor groups, and neighbors that inherit configuration from this session group.

The output from the **show bgp session-group** command is based on the following session group configuration:

```

Router(config)# router bgp 113
Router(config-bgp)# session-group GROUP_1
Router(config-bgp-sngrp)# use session-group GROUP_2
Router(config-bgp-sngrp)# update-source Loopback 0
Router(config-bgp-sngrp)# exit
Router(config-bgp)# session-group GROUP_2
Router(config-bgp-sngrp)# use session-group GROUP_3
Router(config-bgp-sngrp)# ebgp-multihop 2
Router(config-bgp-sngrp)# exit
Router(config-bgp)# session-group GROUP_3
Router(config-bgp-sngrp)# dmz-link-bandwidth

```

The following is sample output from the **show bgp session-group** command with the **configuration** keyword in session group configuration mode:

```

Router# show bgp session-group GROUP_1 configuration

```

```

session-group GROUP_1
  ebgp-multihop 2          [s:GROUP_2]
  update-source Loopback0 []
  dmz-link-bandwidth      [s:GROUP_2 s:GROUP_3]

```

The following is sample output from the **show bgp session-group** command with the **inheritance** keyword showing that the GROUP\_1 session group inherits session parameters from the GROUP\_3 and GROUP\_2 session groups:

```

Router# show bgp session-group GROUP_1 inheritance

Session: s:GROUP_2 s:GROUP_3

```

The following is sample output from the **show bgp session-group** command with the **users** keyword showing that both the GROUP\_1 and GROUP\_2 session groups inherit session parameters from the GROUP\_3 session group:

```

Router# show bgp session-group GROUP_3 users

Session: s:GROUP_1 s:GROUP_2

```

## show bgp session-group

Use the **show bgp session-group** command to display session groups:

- Use the **configuration** keyword to display the effective configuration for the session group, including any settings that have been inherited from session groups used by this session group.
- Use the **inheritance** keyword to display the session groups from which this session group is capable of inheriting configuration.
- Use the **users** keyword to display the session groups, neighbor groups, and neighbors that inherit configuration from this session group.

The output from the **show bgp session-group** command is based on the following session group configuration:

```

Router(config)# router bgp 113
Router(config-bgp)# session-group GROUP_1
Router(config-bgp-sngrp)# use session-group GROUP_2
Router(config-bgp-sngrp)# update-source Loopback 0
Router(config-bgp-sngrp)# exit
Router(config-bgp)# session-group GROUP_2
Router(config-bgp-sngrp)# use session-group GROUP_3
Router(config-bgp-sngrp)# ebgp-multihop 2
Router(config-bgp-sngrp)# exit
Router(config-bgp)# session-group GROUP_3
Router(config-bgp-sngrp)# dmz-link-bandwidth

```

The following is sample output from the **show bgp session-group** command with the **configuration** keyword in session group configuration mode:

```

Router# show bgp session-group GROUP_1 configuration

session-group GROUP_1
  ebgp-multihop 2          [s:GROUP_2]

```

**show bgp neighbor-group**

```
update-source Loopback0 []
dmz-link-bandwidth      [s:GROUP_2 s:GROUP_3]
```

The following is sample output from the **show bgp session-group** command with the **inheritance** keyword showing that the GROUP\_1 session group inherits session parameters from the GROUP\_3 and GROUP\_2 session groups:

```
Router# show bgp session-group GROUP_1 inheritance

Session: s:GROUP_2 s:GROUP_3
```

The following is sample output from the **show bgp session-group** command with the **users** keyword showing that both the GROUP\_1 and GROUP\_2 session groups inherit session parameters from the GROUP\_3 session group:

```
Router# show bgp session-group GROUP_3 users

Session: s:GROUP_1 s:GROUP_2
```

**show bgp neighbor-group**

Use the **show bgp neighbor-group** command to display neighbor groups:

- Use the **configuration** keyword to display the effective configuration for the neighbor group, including any settings that have been inherited from neighbor groups used by this neighbor group.
- Use the **inheritance** keyword to display the address family groups, session groups, and neighbor groups from which this neighbor group is capable of inheriting configuration.
- Use the **users** keyword to display the neighbors and neighbor groups that inherit configuration from this neighbor group.

The examples are based on the following group configuration:

```
Router(config)# router bgp 140
Router(config-bgp)# af-group GROUP_3 address-family ipv4 unicast
Router(config-bgp-afgrp)# remove-private-as
Router(config-bgp-afgrp)# soft-reconfiguration inbound
Router(config-bgp-afgrp)# exit
Router(config-bgp)# af-group GROUP_2 address-family ipv4 unicast
Router(config-bgp-afgrp)# use af-group GROUP_3
Router(config-bgp-afgrp)# send-community ebgp
Router(config-bgp-afgrp)# send-extended-community ebgp
Router(config-bgp-afgrp)# capability orf prefix both
Router(config-bgp-afgrp)# exit
Router(config-bgp)# session-group GROUP_3
Router(config-bgp-sngrp)# timers 30 90
Router(config-bgp-sngrp)# exit
Router(config-bgp)# neighbor-group GROUP_1
Router(config-bgp-nbrgrp)# remote-as 1982
Router(config-bgp-nbrgrp)# use neighbor-group GROUP_2
Router(config-bgp-nbrgrp)# address-family ipv4 unicast
Router(config-bgp-nbrgrp-af)# exit
Router(config-nbrgrp)# exit
Router(config-bgp)# neighbor-group GROUP_2
Router(config-bgp-nbrgrp)# use session-group GROUP_3
```

```
Router(config-bgp-nbrgrp)# address-family ipv4 unicast
Routerconfig-bgp-nbrgrp-af)# use af-group GROUP_2
Router(config-bgp-nbrgrp-af)# weight 100
```

The following is sample output from the **show bgp neighbor-group** command with the **configuration** keyword. The configuration setting source is shown to the right of each command. In the output shown previously, the remote autonomous system is configured directly on neighbor group GROUP\_1, and the send community setting is inherited from neighbor group GROUP\_2, which in turn inherits the setting from address family group GROUP\_3:

```
Router# show bgp neighbor-group GROUP_1 configuration

neighbor-group GROUP_1
remote-as 1982                []
timers 30 90                  [n:GROUP_2 s:GROUP_3]
address-family ipv4 unicast   []
capability orf prefix-list both [n:GROUP_2 a:GROUP_2]
remove-private-AS            [n:GROUP_2 a:GROUP_2 a:GROUP_3]
send-community-ebgp          [n:GROUP_2 a:GROUP_2]
send-extended-community-ebgp [n:GROUP_2 a:GROUP_2]
soft-reconfiguration inbound  [n:GROUP_2 a:GROUP_2 a:GROUP_3]
weight 100                    [n:GROUP_2]
```

The following is sample output from the **show bgp neighbor-group** command with the **inheritance** keyword. This output shows that the specified neighbor group GROUP\_1 inherits session (address family-independent) configuration parameters from neighbor group GROUP\_2. Neighbor group GROUP\_2 inherits its session parameters from session group GROUP\_3. It also shows that the GROUP\_1 neighbor group inherits IPv4 unicast configuration parameters from the GROUP\_2 neighbor group, which in turn inherits them from the GROUP\_2 address family group, which itself inherits them from the GROUP\_3 address family group:

```
Router# show bgp neighbor-group GROUP_1 inheritance

Session:      n:GROUP-2 s:GROUP_3
IPv4 Unicast: n:GROUP_2 a:GROUP_2 a:GROUP_3
```

The following is sample output from the **show bgp neighbor-group** command with the **users** keyword. This output shows that the GROUP\_1 neighbor group inherits session (address family-independent) configuration parameters from the GROUP\_2 neighbor group. The GROUP\_1 neighbor group also inherits IPv4 unicast configuration parameters from the GROUP\_2 neighbor group:

```
Router# show bgp neighbor-group GROUP_2 users

Session:      n:GROUP_1
IPv4 Unicast: n:GROUP_1
```

## No Default Address Family

BGP does not support the concept of a default address family. An address family must be explicitly configured under the BGP router configuration for the address family to be activated in BGP. Similarly, an address family must be explicitly configured under a neighbor for the BGP session to be activated under that address family. It is not required to have any address family configured under the BGP router configuration level for a neighbor

to be configured. However, it is a requirement to have an address family configured at the BGP router configuration level for the address family to be configured under a neighbor.

## Neighbor Address Family Combinations

For default VRF, both IPv4 Unicast and IPv4 Labeled-unicast address families are supported under the same neighbor.

For non-default VRF, both IPv4 Unicast and IPv4 Labeled-unicast address families are not supported under the same neighbor. However, the configuration is accepted on the router with the following error:

```
bgp[1051]: %ROUTING-BGP-4-INCOMPATIBLE_AFI : IPv4 Unicast and IPv4 Labeled-unicast Address families together are not supported under the same neighbor.
```

When one BGP session has both IPv4 unicast and IPv4 labeled-unicast AFI/SAF, then the routing behavior is nondeterministic. Therefore, the prefixes may not be correctly advertised. Incorrect prefix advertisement results in reachability issues. In order to avoid such reachability issues, you must explicitly configure a route policy to advertise prefixes either through IPv4 unicast or through IPv4 labeled-unicast address families.

## Routing Policy Enforcement

External BGP (eBGP) neighbors must have an inbound and outbound policy configured. If no policy is configured, no routes are accepted from the neighbor, nor are any routes advertised to it. This added security measure ensures that routes cannot accidentally be accepted or advertised in the case of a configuration omission error.



---

**Note** This enforcement affects only eBGP neighbors (neighbors in a different autonomous system than this router). For internal BGP (iBGP) neighbors (neighbors in the same autonomous system), all routes are accepted or advertised if there is no policy.

---

## Table Policy

The table policy feature in BGP allows you to configure traffic index values on routes as they are installed in the global routing table. This feature is enabled using the **table-policy** command and supports the BGP policy accounting feature.

BGP policy accounting uses traffic indices that are set on BGP routes to track various counters.

Table policy also provides the ability to drop routes from the RIB based on match criteria. This feature can be useful in certain applications and should be used with caution as it can easily create a routing ‘black hole’ where BGP advertises routes to neighbors that BGP does not install in its global routing table and forwarding table.

## BGP Update Group

When a change to the configuration occurs, the router automatically recalculates update group memberships and applies the changes.

For the best optimization of BGP update group generation, we recommend that the network operator keeps outbound routing policy the same for neighbors that have similar outbound policies. This feature contains commands for monitoring BGP update groups.

## BGP Update Generation and Update Groups

The BGP Update Groups feature separates BGP update generation from neighbor configuration. The BGP Update Groups feature introduces an algorithm that dynamically calculates BGP update group membership based on outbound routing policies. This feature does not require any configuration by the network operator. Update group-based message generation occurs automatically and independently.

## BGP Cost Community

The BGP cost community is a nontransitive extended community attribute that is passed to internal BGP (iBGP) and confederation peers but not to external BGP (eBGP) peers. The cost community feature allows you to customize the local route preference and influence the best-path selection process by assigning cost values to specific routes. The extended community format defines generic points of insertion (POI) that influence the best-path decision at different points in the best-path algorithm.

## How BGP Cost Community Influences the Best Path Selection Process

The cost community attribute influences the BGP best-path selection process at the point of insertion (POI). By default, the POI follows the Interior Gateway Protocol (IGP) metric comparison. When BGP receives multiple paths to the same destination, it uses the best-path selection process to determine which path is the best path. BGP automatically makes the decision and installs the best path in the routing table. The POI allows you to assign a preference to a specific path when multiple equal cost paths are available. If the POI is not valid for local best-path selection, the cost community attribute is silently ignored.

Cost communities are sorted first by POI then by community ID. Multiple paths can be configured with the cost community attribute for the same POI. The path with the lowest cost community ID is considered first. In other words, all cost community paths for a specific POI are considered, starting with the one with the lowest cost community. Paths that do not contain the cost community cost (for the POI and community ID being evaluated) are assigned the default community cost value (2147483647). If the cost community values are equal, then cost community comparison proceeds to the next lowest community ID for this POI.

To select the path with the lower cost community, simultaneously walk through the cost communities of both paths. This is done by maintaining two pointers to the cost community chain, one for each path, and advancing both pointers to the next applicable cost community at each step of the walk for the given POI, in order of community ID, and stop when a best path is chosen or the comparison is a tie. At each step of the walk, the following checks are done:

```

If neither pointer refers to a cost community,
    Declare a tie;

Elseif a cost community is found for one path but not for the other,
    Choose the path with cost community as best path;
Elseif the Community ID from one path is less than the other,
    Choose the path with the lesser Community ID as best path;
Elseif the Cost from one path is less than the other,
    Choose the path with the lesser Cost as best path;
Else Continue.

```



---

**Note** Paths that are not configured with the cost community attribute are considered by the best-path selection process to have the default cost value (half of the maximum value [4294967295] or 2147483647).

---

Applying the cost community attribute at the POI allows you to assign a value to a path originated or learned by a peer in any part of the local autonomous system or confederation. The cost community can be used as a “tie breaker” during the best-path selection process. Multiple instances of the cost community can be configured for separate equal cost paths within the same autonomous system or confederation. For example, a lower cost community value can be applied to a specific exit path in a network with multiple equal cost exit points, and the specific exit path is preferred by the BGP best-path selection process. .



---

**Note** The cost community comparison in BGP is enabled by default. Use the **bgp bestpath cost-community ignore** command to disable the comparison.

---

## Cost Community Support for Aggregate Routes and Multipaths

The BGP cost community feature supports aggregate routes and multipaths. The cost community attribute can be applied to either type of route. The cost community attribute is passed to the aggregate or multipath route from component routes that carry the cost community attribute. Only unique IDs are passed, and only the highest cost of any individual component route is applied to the aggregate for each ID. If multiple component routes contain the same ID, the highest configured cost is applied to the route. For example, the following two component routes are configured with the cost community attribute using an inbound route policy:

- 10.0.0.1
  - POI=IGP
  - cost community ID=1
  - cost number=100
- 192.168.0.1
  - POI=IGP
  - cost community ID=1
  - cost number=200

If these component routes are aggregated or configured as a multipath, the cost value 200 is advertised, because it has the highest cost.

If one or more component routes do not carry the cost community attribute or the component routes are configured with different IDs, then the default value (2147483647) is advertised for the aggregate or multipath route. For example, the following three component routes are configured with the cost community attribute using an inbound route policy. However, the component routes are configured with two different IDs.

- 10.0.0.1
  - POI=IGP



- cost community ID=1
- cost number=100
- 172.16.0.1
  - POI=IGP
  - cost community ID=2
  - cost number=100
- 192.168.0.1
  - POI=IGP
  - cost community ID=1
  - cost number=200

The single advertised path includes the aggregate cost communities as follows:

{POI=IGP, ID=1, Cost=2147483647} {POI=IGP, ID=2, Cost=2147483647}

## Influencing Route Preference in a Multiexit IGP Network

This figure shows an IGP network with two autonomous system boundary routers (ASBRs) on the edge. Each ASBR has an equal cost path to network 10.8/16.

**Figure 5: Multiexit Point IGP Network**

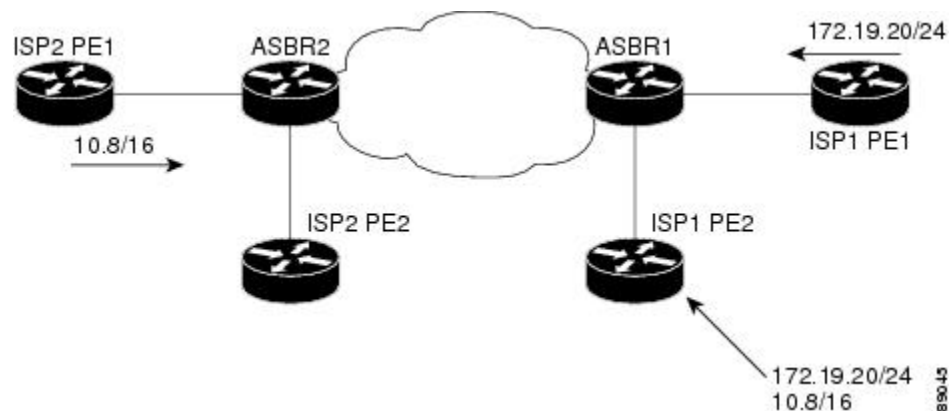

Both paths are considered to be equal by BGP. If multipath loadsharing is configured, both paths to the routing table are installed and are used to balance the load of traffic. If multipath load balancing is not configured, the BGP selects the path that was learned first as the best path and installs this path to the routing table. This behavior may not be desirable under some conditions. For example, the path is learned from ISP1 PE2 first, but the link between ISP1 PE2 and ASBR1 is a low-speed link.

The configuration of the cost community attribute can be used to influence the BGP best-path selection process by applying a lower-cost community value to the path learned by ASBR2. For example, the following configuration is applied to ASBR2:

```
Router(config)# route-policy ISP2_PE1
```

```
Router(config-rpl)# set extcommunity cost (1:1)
```

The preceding route policy applies a cost community number of 1 to the 10.8.0.0 route. By default, the path learned from ASBR1 is assigned a cost community number of 2147483647. Because the path learned from ASBR2 has a lower-cost community number, the path is preferred.

## Adding Routes to the Routing Information Base

If a nonsourced path becomes the best path after the best-path calculation, BGP adds the route to the Routing Information Base (RIB) and passes the cost communities along with the other IGP extended communities.

When a route with paths is added to the RIB by a protocol, RIB checks the current best paths for the route and the added paths for cost extended communities. If cost-extended communities are found, the RIB compares the set of cost communities. If the comparison does not result in a tie, the appropriate best path is chosen. If the comparison results in a tie, the RIB proceeds with the remaining steps of the best-path algorithm. If a cost community is not present in either the current best paths or added paths, then the RIB continues with the remaining steps of the best-path algorithm.

## BGP DMZ Aggregate Bandwidth

Table 3: Feature History Table

Feature Name	Release Information	Feature Description
Removal of Link-Bandwidth Extended Community to iBGP Peers	Release 7.3.2	The demilitarized zone (DMZ) link-bandwidth extended community allows BGP to send traffic over multiple internal BGP (iBGP) learned paths. The traffic that is sent is proportional to the bandwidth of the links that are used to exit the autonomous system. By default, iBGP propagates DMZ link-bandwidth community. This feature minimizes the risk of exposure of the community parameters, which are used to control the routing policy in the service provider network, to networks zones where they are not recognized or not required.

BGP supports aggregating *dmz-link bandwidth* values of external BGP (eBGP) multipaths when advertising the route to interior BGP (iBGP) peer.

There is no explicit command to aggregate bandwidth. The bandwidth is aggregated if following conditions are met:

- The network has multipaths and all the multipaths have link-bandwidth values.
- The next-hop attribute set to next-hop-self. The next-hop attribute for all routes advertised to the specified neighbor to the address of the local router.
- There is no out-bound policy configured that might change the dmz-link bandwidth value.
- If the *dmz-link bandwidth* value is not known for any one of the multipaths (eBGP or iBGP), the *dmz-link* value for all multipaths including the best path is not downloaded to routing information base (RIB).
- The *dmz-link bandwidth* value of iBGP multipath is not considered during aggregation.
- The route that is advertised with aggregate value can be best path or add-path.

- Add-path does not qualify for DMZ link bandwidth aggregation as next hop is preserved. Configuring next-hop-self for add-path is not supported.
- For VPNv4 and VPNv6 afi, if *dmz link-bandwidth* value is configured using outbound route-policy, specify the route table or use the **additive** keyword. Else, this will lead to routes not imported on the receiving end of the peer.

```

extcommunity-set bandwidth dmz_ext
  1:8000
end-set
!
route-policy dmz_rp_vpn
  set extcommunity bandwidth dmz_ext additive    <<< 'additive' keyword.
  pass
end-policy

```

### Removal of Link-Bandwidth Extended Community to iBGP Peers

The demilitarized zone (DMZ) link-bandwidth extended community allows BGP to send traffic over multiple internal BGP (iBGP) learned paths. The traffic that is sent is proportional to the bandwidth of the links that are used to exit the autonomous system. By default, iBGP propagates DMZ link-bandwidth community. The Removal of Link-Bandwidth Extended Community to iBGP Peers feature provides the flexibility to remove the DMZ link-bandwidth community to minimize the risk of exposure of the community parameters to networks zones where they are not recognized or unnecessary.

### Configuration Example

Perform the following steps to allow users to be able to configure route-policy to remove the extended communities.

```

/* Delete all the extended communities. */
Router(config)# route-policy dmz_del_all
Router(config-rpl)# delete extcommunity bandwidth all
Router(config-rpl)# pass
Router(config-rpl)# end-policy

/* Delete only the extended communities that match an extended community mentioned in the
list. */
Router(config)# route-policy dmz_CE1_del_non_match
Router(config-rpl)# if destination in (10.9.9.9/32) then
Router(config-rpl-if)# delete extcommunity bandwidth in (10:7000)
Router(config-rpl-if)# endif
Router(config-rpl)# pass
Router(config-rpl)# end-policy

/* Delete all the extended communities. */
Router(config)# route-policy dmz_del_param2($a,$b)
Router(config-rpl)# if destination in (10.9.9.9/32) then
Router(config-rpl-if)# delete extcommunity bandwidth in ($a:$b)
Router(config-rpl-if)# endif
Router(config-rpl)# pass
Router(config-rpl)# end-policy

```

### Verification

Verify the configuration that allows the user to remove a particular extended community.

```

Router# show bgp 10.9.9.9/32
Fri Aug 27 13:15:05.833 EDT

```

```

BGP routing table entry for 10.9.9.9/32
Versions:
Process bRIB/RIB SendTblVer
Speaker 15 15
Last Modified: Aug 27 13:06:45.000 for 00:08:21
Paths: (3 available, best #1)
Advertised IPv4 Unicast paths to peers (in unique update groups):
13.13.13.5
Path #1: Received by speaker 0
Advertised IPv4 Unicast paths to peers (in unique update groups):
13.13.13.5
10
10.10.10.1 from 10.10.10.1 (192.168.0.1)
Origin incomplete, metric 0, localpref 100, valid, external, best, group-best, multipath
Received Path ID 0, Local Path ID 1, version 15
Extended community: LB:10:48
Origin-AS validity: (disabled)
Path #2: Received by speaker 0
Not advertised to any peer
10
11.11.11.3 from 11.11.11.3 (192.168.0.3)
Origin incomplete, metric 0, localpref 100, valid, external, multipath
Received Path ID 0, Local Path ID 0, version 0
Extended community: LB:10:48
Origin-AS validity: (disabled)
Path #3: Received by speaker 0
Not advertised to any peer
10
12.12.12.4 from 12.12.12.4 (192.168.0.4)
Origin incomplete, metric 0, localpref 100, valid, external, multipath
Received Path ID 0, Local Path ID 0, version 0
Extended community: LB:10:48
Origin-AS validity: (disabled)

22:35 30-09-2021

```

## Configuring BGP DMZ Aggregate Bandwidth: Example

This is a sample configuration for Border Gateway Protocol Demilitarized Zone (BGP DMZ) link bandwidth. Consider the topology, R1---(iBGP)---R2---(iBGP)---R3:

### 1. On R1:

```

bgp: prefix p/n has:
path 1(bestpath)          with LB value 100
path 2(ebgp multipath)    with LB value 30
path 3(ebgp multipath)    with LB value 50

```

When best path is advertised to R2, send aggregated dmz-link bandwidth value of 180; aggregated value of paths 1, 2 and 3.

### 2. On R2:

```

bgp: prefix p/n has:
path 1(bestpath)          with LB value 60
path 2(ebgp multipath)    with LB value 200
path 3(ebgp multipath)    with LB value 50

```

When best path is advertised to R3, send aggregated dmz-link bandwidth value of 310; aggregated value of paths 1, 2 and 3.

### 3. On R3:

```

bgp: prefix p/n has:
path 1(bestpath)      with LB 180 {learned from R1}
path 2(ibgp multipath) with LB 310 {learned from R2}

```

## Configuring Policy-based Link Bandwidth: Example

This is a sample configuration for policy-based DMZ link bandwidth. The link-bandwidth ext-community can be set on a *per-path* basis either at the neighbor-in or neighbor-out policy attach-points. The *dmz-link-bandwidth* knob is configured under eBGP neighbor configuration mode. All paths received from that particular neighbor will be marked with the link-bandwidth extended community when sent to iBGP peers.

### 1. Configure inbound or outbound route-policy.

```

extcommunity-set bandwidth dmz_ext
  1:1290400000
end-set
!
route-policy dmz_rp
  set extcommunity bandwidth dmz_ext
  pass
end-policy
!

neighbor 10.0.101.1
  remote-as 1001
  address-family ipv4 unicast
    route-policy dmz_rp in          <<< Inbound route-policy.
    route-policy pass out
  !

```

### 2. Configure *dmz-link-bandwidth* under BGP neighbor.

```

neighbor 10.0.101.2
  remote-as 1001
  dmz-link-bandwidth              <<< Under neighbor.
  address-family ipv4 unicast
    route-policy pass in
    route-policy pass out
  !

```

## 64-ECMP Support for BGP

IOS XR supports configuration of up to 64 equal cost multipath (ECMP) next hops for BGP. 64-ECMP is required in networks, where overloaded routers can load balance the traffic over as many as 64 LSPs.

## BGP Best Path Algorithm

BGP routers typically receive multiple paths to the same destination. The BGP best-path algorithm determines the best path to install in the IP routing table and to use for forwarding traffic. This section describes the Cisco IOS XR software implementation of BGP best-path algorithm, as specified in Section 9.1 of the Internet Engineering Task Force (IETF) Network Working Group draft-ietf-idr-bgp4-24.txt document.

The BGP best-path algorithm implementation is in three parts:

- Part 1—Compares two paths to determine which is better.

- Part 2—Iterates over all paths and determines which order to compare the paths to select the overall best path.
- Part 3—Determines whether the old and new best paths differ enough so that the new best path should be used.



---

**Note** The order of comparison determined by Part 2 is important because the comparison operation is not transitive; that is, if three paths, A, B, and C exist, such that when A and B are compared, A is better, and when B and C are compared, B is better, it is not necessarily the case that when A and C are compared, A is better. This nontransitivity arises because the multi exit discriminator (MED) is compared only among paths from the same neighboring autonomous system (AS) and not among all paths.

---

## Comparing Pairs of Paths

Perform the following steps to compare two paths and determine the better path:

1. If either path is invalid (for example, a path has the maximum possible MED value or it has an unreachable next hop), then the other path is chosen (provided that the path is valid).
2. If the paths have unequal pre-bestpath cost communities, the path with the lower pre-bestpath cost community is selected as the best path.
3. If the paths have unequal weights, the path with the highest weight is chosen.



---

**Note** The weight is entirely local to the router, and can be set with the **weight** command or using a routing policy.

---

4. If the paths have unequal local preferences, the path with the higher local preference is chosen.



---

**Note** If a local preference attribute was received with the path or was set by a routing policy, then that value is used in this comparison. Otherwise, the default local preference value of 100 is used. The default value can be changed using the **bgp default local-preference** command.

---

5. If one of the paths is a redistributed path, which results from a **redistribute** or **network** command, then it is chosen. Otherwise, if one of the paths is a locally generated aggregate, which results from an **aggregate-address** command, it is chosen.



---

**Note** Step 1 through Step 4 implement the “Path Selection with BGP” of RFC 1268.

---

6. If the paths have unequal AS path lengths, the path with the shorter AS path is chosen. This step is skipped if **bgp bestpath as-path ignore** command is configured.



---

**Note** When calculating the length of the AS path, confederation segments are ignored, and AS sets count as 1.

---



---

**Note** eiBGP specifies internal and external BGP multipath peers. eiBGP allows simultaneous use of internal and external paths.

---

7. If the paths have different origins, the path with the lower origin is selected. Interior Gateway Protocol (IGP) is considered lower than EGP, which is considered lower than INCOMPLETE.
8. If appropriate, the MED of the paths is compared. If they are unequal, the path with the lower MED is chosen.

A number of configuration options exist that affect whether or not this step is performed. In general, the MED is compared if both paths were received from neighbors in the same AS; otherwise the MED comparison is skipped. However, this behavior is modified by certain configuration options, and there are also some corner cases to consider.

If the **bgp bestpath med always** command is configured, then the MED comparison is always performed, regardless of neighbor AS in the paths. Otherwise, MED comparison depends on the AS paths of the two paths being compared, as follows:

- If a path has no AS path or the AS path starts with an AS\_SET, then the path is considered to be internal, and the MED is compared with other internal paths.
- If the AS path starts with an AS\_SEQUENCE, then the neighbor AS is the first AS number in the sequence, and the MED is compared with other paths that have the same neighbor AS.
- If the AS path contains only confederation segments or starts with confederation segments followed by an AS\_SET, then the MED is not compared with any other path unless the **bgp bestpath med confed** command is configured. In that case, the path is considered internal and the MED is compared with other internal paths.
- If the AS path starts with confederation segments followed by an AS\_SEQUENCE, then the neighbor AS is the first AS number in the AS\_SEQUENCE, and the MED is compared with other paths that have the same neighbor AS.



---

**Note** If no MED attribute was received with the path, then the MED is considered to be 0 unless the **bgp bestpath med missing-as-worst** command is configured. In that case, if no MED attribute was received, the MED is considered to be the highest possible value.

---

9. If one path is received from an external peer and the other is received from an internal (or confederation) peer, the path from the external peer is chosen.
10. If the paths have different IGP metrics to their next hops, the path with the lower IGP metric is chosen.
11. If the paths have unequal IP cost communities, the path with the lower IP cost community is selected as the best path.
12. If all path parameters in Step 1 through Step 10 are the same, then the router IDs are compared. If the path was received with an originator attribute, then that is used as the router ID to compare; otherwise, the router ID of the neighbor from which the path was received is used. If the paths have different router IDs, the path with the lower router ID is chosen.



---

**Note** Where the originator is used as the router ID, it is possible to have two paths with the same router ID. It is also possible to have two BGP sessions with the same peer router, and therefore receive two paths with the same router ID.

---

13. If the paths have different cluster lengths, the path with the shorter cluster length is selected. If a path was not received with a cluster list attribute, it is considered to have a cluster length of 0.
14. Finally, the path received from the neighbor with the lower IP address is chosen. Locally generated paths (for example, redistributed paths) are considered to have a neighbor IP address of 0.

## Order of Comparisons

The second part of the BGP best-path algorithm implementation determines the order in which the paths should be compared. The order of comparison is determined as follows:

1. The paths are partitioned into groups such that within each group the MED can be compared among all paths. The same rules as in *Comparing Paths* section are used to determine whether MED can be compared between any two paths. Normally, this comparison results in one group for each neighbor AS. If the **bgp bestpath med always** command is configured, then there is just one group containing all the paths.
2. The best path in each group is determined. Determining the best path is achieved by iterating through all paths in the group and keeping track of the best one seen so far. Each path is compared with the best-so-far, and if it is better, it becomes the new best-so-far and is compared with the next path in the group.
3. A set of paths is formed containing the best path selected from each group in Step 2. The overall best path is selected from this set of paths, by iterating through them as in Step 2.

## Best Path Change Suppression

The third part of the implementation is to determine whether the best-path change can be suppressed or not—whether the new best path should be used, or continue using the existing best path. The existing best path can continue to be used if the new one is identical to the point at which the best-path selection algorithm becomes arbitrary (if the router-id is the same). Continuing to use the existing best path can avoid churn in the network.



---

**Note** This suppression behavior does not comply with the IETF Networking Working Group draft-ietf-idr-bgp4-24.txt document, but is specified in the IETF Networking Working Group draft-ietf-idr-avoid-transition-00.txt document.

---

The suppression behavior can be turned off by configuring the **bgp bestpath compare-routerid** command. If this command is configured, the new best path is always preferred to the existing one.

Otherwise, the following steps are used to determine whether the best-path change can be suppressed:

1. If the existing best path is no longer valid, the change cannot be suppressed.
2. If either the existing or new best paths were received from internal (or confederation) peers or were locally generated (for example, by redistribution), then the change cannot be suppressed. That is, suppression is possible only if both paths were received from external peers.



3. If the paths were received from the same peer (the paths would have the same router-id), the change cannot be suppressed. The router ID is calculated using rules in *Comparing Pairs of Paths* section.
4. If the paths have different weights, local preferences, origins, or IGP metrics to their next hops, then the change cannot be suppressed. Note that all these values are calculated using the rules in *Comparing Pairs of Paths* section..
5. If the paths have different-length AS paths and the **bgp bestpath as-path ignore** command is not configured, then the change cannot be suppressed. Again, the AS path length is calculated using the rules in *Comparing Pairs of Paths* section.
6. If the MED of the paths can be compared and the MEDs are different, then the change cannot be suppressed. The decision as to whether the MEDs can be compared is exactly the same as the rules in *Comparing Pairs of Paths* section, as is the calculation of the MED value.
7. If all path parameters in Step 1 through Step 6 do not apply, the change can be suppressed.

## Administrative Distance

An administrative distance is a rating of the trustworthiness of a routing information source. In general, the higher the value, the lower the trust rating.

Normally, a route can be learned through more than one protocol. Administrative distance is used to discriminate between routes learned from more than one protocol. The route with the lowest administrative distance is installed in the IP routing table. By default, BGP uses the administrative distances shown in *BGP Default Administrative Distances* section.

**Table 4: BGP Default Administrative Distances**

Distance	Default Value	Function
External	20	Applied to routes learned from eBGP.
Internal	200	Applied to routes learned from iBGP.
Local	200	Applied to routes originated by the router.





---

**Note** Distance does not influence the BGP path selection algorithm, but it does influence whether BGP-learned routes are installed in the IP routing table.

---

In most cases, when a route is learned through eBGP, it is installed in the IP routing table because of its distance (20). Sometimes, however, two ASs have an IGP-learned back-door route and an eBGP-learned route. Their policy might be to use the IGP-learned path as the preferred path and to use the eBGP-learned path when the IGP path is down.

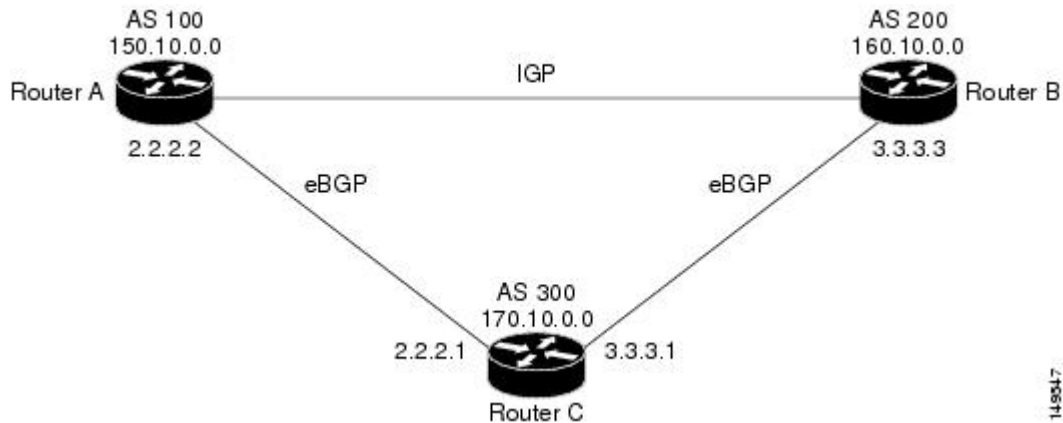
Figure 6: Back Door Example



In *Back Door Example* section, Routers A and C and Routers B and C are running eBGP. Routers A and B are running an IGP (such as Routing Information Protocol [RIP], Interior Gateway Routing Protocol [IGRP], Enhanced IGRP, or Open Shortest Path First [OSPF]). The default distances for RIP, IGRP, Enhanced IGRP, and OSPF are 120, 100, 90, and 110, respectively. All these distances are higher than the default distance of eBGP, which is 20. Usually, the route with the lowest distance is preferred.

Router A receives updates about 160.10.0.0 from two routing protocols: eBGP and IGP. Because the default distance for eBGP is lower than the default distance of the IGP, Router A chooses the eBGP-learned route from Router C. If you want Router A to learn about 160.10.0.0 from Router B (IGP), establish a BGP back door. See .

In the following example, a network back-door is configured:

```
Router(config)# router bgp 100
Router(config-bgp)# address-family ipv4 unicast
Router(config-bgp-af)# network 160.10.0.0/16 backdoor
```

Router A treats the eBGP-learned route as local and installs it in the IP routing table with a distance of 200. The network is also learned through Enhanced IGRP (with a distance of 90), so the Enhanced IGRP route is successfully installed in the IP routing table and is used to forward traffic. If the Enhanced IGRP-learned route goes down, the eBGP-learned route is installed in the IP routing table and is used to forward traffic.

Although BGP treats network 160.10.0.0 as a local entry, it does not advertise network 160.10.0.0 as it normally would advertise a local entry.

## Route Dampening

Route dampening is a BGP feature that minimizes the propagation of flapping routes across an internetwork. A route is considered to be flapping when it is repeatedly available, then unavailable, then available, then unavailable, and so on.

For example, consider a network with three BGP autonomous systems: autonomous system 1, autonomous system 2, and autonomous system 3. Suppose the route to network A in autonomous system 1 flaps (it becomes unavailable). Under circumstances without route dampening, the eBGP neighbor of autonomous system 1 to autonomous system 2 sends a withdraw message to autonomous system 2. The border router in autonomous system 2, in turn, propagates the withdrawal message to autonomous system 3. When the route to network A reappears, autonomous system 1 sends an advertisement message to autonomous system 2, which sends it to

autonomous system 3. If the route to network A repeatedly becomes unavailable, then available, many withdrawal and advertisement messages are sent. Route flapping is a problem in an internetwork connected to the Internet, because a route flap in the Internet backbone usually involves many routes.

## Minimize Flapping

The route dampening feature minimizes the flapping problem as follows. Suppose again that the route to network A flaps. The router in autonomous system 2 (in which route dampening is enabled) assigns network A a penalty of 1000 and moves it to history state. The router in autonomous system 2 continues to advertise the status of the route to neighbors. The penalties are cumulative. When the route flaps so often that the penalty exceeds a configurable suppression limit, the router stops advertising the route to network A, regardless of how many times it flaps. Thus, the route is dampened.

The penalty placed on network A is decayed until the reuse limit is reached, upon which the route is once again advertised. At half of the reuse limit, the dampening information for the route to network A is removed.



---

**Note** No penalty is applied to a BGP peer reset when route dampening is enabled, even though the reset withdraws the route.

---

## BGP Routing Domain Confederation

One way to reduce the iBGP mesh is to divide an autonomous system into multiple sub-autonomous systems and group them into a single confederation. To the outside world, the confederation looks like a single autonomous system. Each autonomous system is fully meshed within itself and has a few connections to other autonomous systems in the same confederation. Although the peers in different autonomous systems have eBGP sessions, they exchange routing information as if they were iBGP peers. Specifically, the next hop, MED, and local preference information is preserved. This feature allows you to retain a single IGP for all of the autonomous systems.

## BGP Optimal Route Reflector

BGP-ORR (optimal route reflector) enables virtual route reflector (vRR) to calculate the best path from a route reflector (RR) client's point of view.

BGP ORR calculates the best path by:

1. Running SPF multiple times in the context of its RR clients or RR clusters (set of RR clients)
2. Saving the result of different SPF runs in separate databases
3. Using these databases to manipulate BGP best path decision and thereby allowing BGP to use and announce best path that is optimal from the client's point of view



---

**Note** Enabling the ORR feature increases the memory footprint of BGP and RIB. With increased number of vRR configured in the network, ORR adversely impacts convergence for BGP.

---

In an autonomous system, a BGP route reflector acts as a focal point and advertises routes to its peers (RR clients) along with the RR's computed best path. Since the best path advertised by the RR is computed from the RR's point of view, the RR's placement becomes an important deployment consideration.

With network function virtualization (NFV) becoming a dominant technology, service providers (SPs) are hosting virtual RR functionality in a cloud using servers. A vRR can run on a control plane device and can be placed anywhere in the topology or in a SP data center. Cisco IOS XRv 9000 Router can be implemented as vRR over a NFV platform in a SP data center. vRR allows SPs to scale memory and CPU usage of RR deployments significantly. Moving a RR out of its optimal placement requires vRRs to implement ORR functionality that calculates the best path from a RR client's point of view.

BGP ORR offers these benefits:

- Calculates the bestpath from the point of view of a RR client.
- Enables vRR to be placed anywhere in the topology or in a SP data center.
- Allows SPs to scale memory and CPU usage of RR deployments.

## Use Case

Consider a BGP Route Reflector topology where:

- Router R1, R2, R3, R4, R5 and R6 are route reflector clients
- Router R1 and R4 advertise 6/8 prefix to vRR

**Figure 7: BGP-ORR Topology**

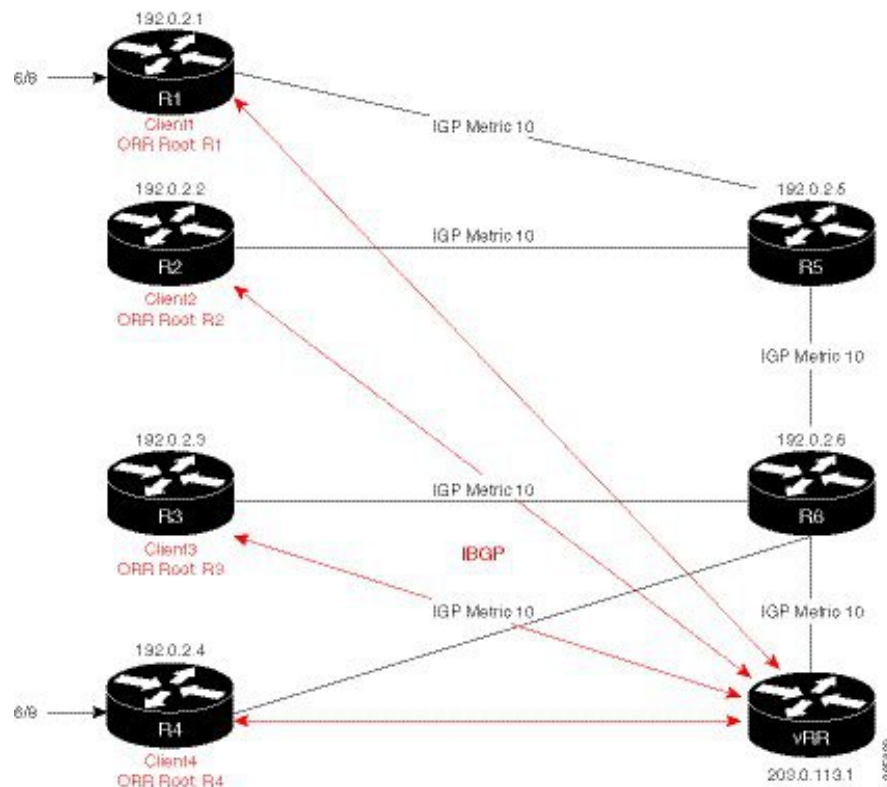

vRR receives prefix 6/8 from R1 and R4. Without BGP ORR configured in the network, the vRR selects R4 as the closest exit point for RR clients R2, R3, R5, and R6, and reflects the 6/8 prefix learned from R4 to these RR clients R2, R3, R5, and R6. From the topology, it is evident that for R2 the best path is R1 and not R4. This is because the vRR calculates best path from the RR's point of view.

When the BGP ORR is configured in the network, the vRR calculates the shortest exit point in the network from R2's point of view (ORR Root: R2) and determines that R1 is the closest exit point to R2. vRR then reflects the 6/8 prefix learned from R1 to R2.

Configuring BGP ORR includes:

- enabling ORR on the RR for the client whose shortest exit point is to be determined
- applying the ORR configuration to the neighbor

### Enabling ORR on vRR for R2 (RR client)

For example to determine shortest exit point for R2; configure ORR on vRR with an IP address of R2 that is 192.0.2.2. Use 6500 as AS number and g1 as orr (root) policy name:

```
router bgp 6500
  address-family ipv4 unicast
    optimal-route-reflection g1 192.0.2.2
  commit
```

### Applying the ORR configuration to the neighbor

Next, apply the ORR policy to BGP neighbor R2 (this enables RR to advertise best path calculated using the root IP address, 192.0.2.2, configured in orr (root) policy g1 to R2):

```
router bgp 6500
  neighbor 192.0.2.2
    address-family ipv4 unicast
      optimal-route-reflection g1
  commit
```

### Configuring MPLS Traffic-Engineering on Root Router

The root routers advertise the Multi Protocol Label Switching (MPLS) TE router-ID that matches with the configured root address on the RR. So, you must configure the root router with a minimal MPLS TE configuration to advertise this MPLS TE router-ID. The minimal set of commands that you need to configure depends on the operating system of the root router.

The following is a sample configuration on the root router:

```
router isis 100

is-type level-2-only

net 49.0001.0000.0000.0001.00

distribute link-state

  metric-style wide

  mpls traffic-eng level-2-only
```

```

mpls traffic-eng router-id Loopback0

!

mpls traffic-eng

```

## Verification

To verify whether R2 received the best exit, execute the **show bgp <prefix>** command (from R2) in EXEC mode. In the above example, R1 and R4 advertise the 6/8 prefix; run the **show bgp 6.0.0.0/8** command:

```

R2# show bgp 6.0.0.0/8
Tue Apr  5 20:21:58.509 UTC
BGP routing table entry for 6.0.0.0/8
Versions:
  Process          bRIB/RIB  SendTblVer
  Speaker          8         8
Last Modified: Apr  5 20:00:44.022 for 00:21:14
Paths: (1 available, best #1)
  Not advertised to any peer
  Path #1: Received by speaker 0
  Not advertised to any peer
  Local
    192.0.2.1 (metric 20) from 203.0.113.1 (192.0.2.1)
      Origin incomplete, metric 0, localpref 100, valid, internal, best, group-best
      Received Path ID 0, Local Path ID 1, version 8
      Originator: 192.0.2.1, Cluster list: 203.0.113.1

```

The above show output states that the best path for R2 is through R1, whose IP address is 192.0.2.1 and the metric of the path is 20.

Execute the **show bgp** command from the vRR to determine the best path calculated for R2 by ORR. R2 has its own update-group because it has a different best path (or different policy configured) than those of other peers:

```

VRR#show bgp 6.0.0.0/8
Thu Apr 28 13:36:42.744 UTC
BGP routing table entry for 6.0.0.0/8
Versions:
Process bRIB/RIB SendTblVer
Speaker 13 13
Last Modified: Apr 28 13:36:26.909 for 00:00:15
Paths: (2 available, best #2)
Advertised to update-groups (with more than one peer):
0.2
Path #1: Received by speaker 0
ORR bestpath for update-groups (with more than one peer):
0.1
Local, (Received from a RR-client)
192.0.2.1 (metric 30) from 192.0.2.1 (192.0.2.1)
Origin incomplete, metric 0, localpref 100, valid, internal, add-path
Received Path ID 0, Local Path ID 2, version 13
Path #2: Received by speaker 0
Advertised to update-groups (with more than one peer):
0.2
ORR addpath for update-groups (with more than one peer):
0.1
Local, (Received from a RR-client)
192.0.2.4 (metric 20) from 192.0.2.4 (192.0.2.4)
Origin incomplete, metric 0, localpref 100, valid, internal, best, group-best

```

Received Path ID 0, Local Path ID 1, version 13



**Note** Path #1 is advertised to update-group 0.1. R2 is in update-group 0.1.

Execute the **show bgp** command for update-group 0.1 verify whether R2 is in update-group 0.1.

```
VRR#show bgp update-group 0.1
Thu Apr 28 13:38:18.517 UTC

Update group for IPv4 Unicast, index 0.1:
Attributes:
Neighbor sessions are IPv4
Internal
Common admin
First neighbor AS: 65000
Send communities
Send GSHUT community if originated
Send extended communities
Route Reflector Client
ORR root (configured): g1; Index: 0
4-byte AS capable
Non-labeled address-family capable
Send AIGP
Send multicast attributes
Minimum advertisement interval: 0 secs
Update group desynchronized: 0
Sub-groups merged: 0
Number of refresh subgroups: 0
Messages formatted: 5, replicated: 5
All neighbors are assigned to sub-group(s)
Neighbors in sub-group: 0.2, Filter-Groups num:1
Neighbors in filter-group: 0.2(RT num: 0)
192.0.2.2
```

For further verification, check the contents of the table created on vRR as a result of configuring the g1 policy. From R2's point of view, the cost of reaching R1 is 20 and the cost of reaching R4 is 30. Therefore, the closest and best exit for R2 is through R1:

```
VRR#show orrspf database g1
Thu Apr 28 13:39:20.333 UTC

ORR policy: g1, IPv4, RIB tableid: 0xe0000011
Configured root: primary: 192.0.2.2, secondary: NULL, tertiary: NULL
Actual Root: 192.0.2.2, Root node: 2000.0100.1002.0000

Prefix Cost
203.0.113.1 30
192.0.2.1 20
192.0.2.2 0
192.0.2.3 30
192.0.2.4 30
192.0.2.5 10
192.0.2.6 20

Number of mapping entries: 8
```

## RPL - if prefix is-best-path/is-best-multipath

Border Gateway Protocol (BGP) routers receive multiple paths to the same destination. As a standard, by default the BGP best path algorithm decides the best path to install in IP routing table. This is used for traffic forwarding.

BGP assigns the first valid path as the current best path. It then compares the best path with the next in the list. This process continues, until BGP reaches the end of the list of valid paths. This contains all rules used to determine the best path. When there are multiple paths for a given address prefix, BGP:

- Selects one of the paths as the best path as per the best-path selection rules.
- Installs the best path in its forwarding table. Each BGP speaker advertises only the best-path to its peers.



---

**Note** The advertisement rule of sending only the best path does not convey the full routing state of a destination, present on a BGP speaker to its peers.

---

After the BGP speaker receives a path from one of its peers; the path is used by the peer for forwarding packets. All other peers receive the same path from this peer. This leads to a consistent routing in a BGP network. To improve the link bandwidth utilization, most BGP implementations choose additional paths satisfy certain conditions, as multi-path, and install them in the forwarding table. Incoming packets for such are load-balanced across the best-path and the multi-path(s). You can install the paths in the forwarding table that are not advertised to the peers. The RR route reflector finds out the best-path and multi-path. This way the route reflector uses different communities for best-path and multi-path. This feature allows BGP to signal the local decision done by RR or Border Router. With this new feature, selected by RR using community-string (if is-best-path then community 100:100). The controller checks which best path is sent to all R's. Border Gateway Protocol routers receive multiple paths to the same destination. While carrying out best path computation there will be one best path, sometimes equal and few non-equal paths. Thus, the requirement for a best-path and is-equal-best-path.

The BGP best path algorithm decides the best path in the IP routing table and used for forwarding traffic. This enhancement within the RPL allows creating policy to take decisions. Adding community-string for local selection of best path. With introduction of BGP Additional Path (Add Path), BGP now signals more than the best Path. BGP can signal the best path and the entire path equivalent to the best path. This is in accordance to the BGP multi-path rules and all backup paths.

## Remotely Triggered Blackhole Filtering with RPL Next-hop Discard Configuration

Remotely triggered black hole (RTBH) filtering is a technique that provides the ability to drop undesirable traffic before it enters a protected network. RTBH filtering provides a method for quickly dropping undesirable traffic at the edge of the network, based on either source addresses or destination addresses by forwarding it to a null0 interface. RTBH filtering based on a destination address is commonly known as Destination-based RTBH filtering. Whereas, RTBH filtering based on a source address is known as Source-based RTBH filtering.

RTBH filtering is one of the many techniques in the security toolkit that can be used together to enhance network security in the following ways:

- Effectively mitigate DDoS and worm attacks



- Quarantine all traffic destined for the target under attack
- Enforce blacklist filtering

## Configure Destination-based RTBH Filtering

RTBH is implemented by defining a route policy (RPL) to discard undesirable traffic at next-hop using **set next-hop discard** command.

RTBH filtering sets the next-hop of the victim's prefix to the null interface. The traffic destined to the victim is dropped at the ingress.

The **set next-hop discard** configuration is used in the neighbor inbound policy. When this config is applied to a path, though the primary next-hop is associated with the actual path but the RIB is updated with next-hop set to Null0. Even if the primary received next-hop is unreachable, the RTBH path is considered reachable and will be a candidate in the bestpath selection process. The RTBH path is readvertised to other peers with either the received next-hop or nexthop-self based on normal BGP advertisement rules.

A typical deployment scenario for RTBH filtering would require running internal Border Gateway Protocol (iBGP) at the access and aggregation points and configuring a separate device in the network operations center (NOC) to act as a trigger. The triggering device sends iBGP updates to the edge, that cause undesirable traffic to be forwarded to a null0 interface and dropped.

Consider below topology, where a rogue router is sending traffic to a border router.

**Figure 8: Topology to Implement RTBH Filtering**

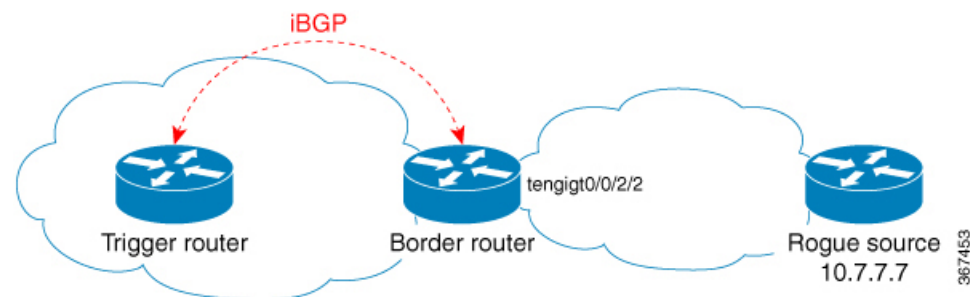

### Configurations applied on the Trigger Router

Configure a static route redistribution policy that sets a community on static routes marked with a special tag, and apply it in BGP:

```
route-policy RTBH-trigger
  if tag is 777 then
    set community (1234:4321, no-export) additive
  pass
  else
    pass
  endif
end-policy

router bgp 65001
  address-family ipv4 unicast
    redistribute static route-policy RTBH-trigger
  !
  neighbor 192.168.102.1
    remote-as 65001
```

```
address-family ipv4 unicast
route-policy bgp_all in
route-policy bgp_all out
```

Configure a static route with the special tag for the source prefix that has to be block-holed:

```
router static
address-family ipv4 unicast
10.7.7.7/32 Null0 tag 777
```

### Configurations applied on the Border Router

Configure a route policy that matches the community set on the trigger router and configure set next-hop discard:

```
route-policy RTBH
if community matches-any (1234:4321) then
set next-hop discard
else
pass
endif
end-policy
```

Apply the route policy on the iBGP peers:

```
router bgp 65001
address-family ipv4 unicast
!
neighbor 192.168.102.2
remote-as 65001
address-family ipv4 unicast
route-policy RTBH in
route-policy bgp_all out
```

## Default Address Family for show Commands

Most of the **show** commands provide address family (AFI) and subaddress family (SAFI) arguments (see RFC 1700 and RFC 2858 for information on AFI and SAFI). The Cisco IOS XR software parser provides the ability to set the **afi** and **safi** so that it is not necessary to specify them while running a **show** command. The parser commands are:

- **set default-afi** { **ipv4** | **ipv6** | **all** }
- **set default-safi** { **unicast** | **multicast** | **all** }

The parser automatically sets the default **afi** value to **ipv4** and default **safi** value to **unicast**. It is necessary to use only the parser commands to change the default **afi** value from **ipv4** or default **safi** value from **unicast**. Any **afi** or **safi** keyword specified in a **show** command overrides the values set using the parser commands. Use the following **show default-afi-safi-vrf** command to check the currently set value of the **afi** and **safi**.

## TCP Maximum Segment Size

Maximum Segment Size (MSS) is the largest amount of data that a computer or a communication device can receive in a single, unfragmented TCP segment. All TCP sessions are bounded by a limit on the number of

bytes that can be transported in a single packet; this limit is MSS. TCP breaks up packets into chunks in a transmit queue before passing packets down to the IP layer.

The TCP MSS value is dependent on the maximum transmission unit (MTU) of an interface, which is the maximum length of data that can be transmitted by a protocol at one instance. The maximum TCP packet length is determined by both the MTU of the outbound interface on the source device and the MSS announced by the destination device during the TCP setup process. The closer the MSS is to the MTU, the more efficient is the transfer of BGP messages. Each direction of data flow can use a different MSS value.

## Per Neighbor TCP MSS

The per neighbor TCP MSS feature allows you to create unique TCP MSS profiles for each neighbor. Per neighbor TCP MSS is supported in two modes: neighbor group and session group. Before, TCP MSS configuration was available only at the global level in the BGP configuration.

The per neighbor TCP MSS feature allows you to:

- Enable per neighbor TCP MSS configuration.
- Disable TCP MSS for a particular neighbor in the neighbor group or session group using the **inheritance-disable** command.
- Unconfigure TCP MSS value. On unconfiguration, TCP MSS value in the protocol control block (PCB) is set to the default value.



---

**Note** The default TCP MSS value is 536 (in octets) or 1460 (in bytes). The MSS default of 1460 means that TCP segments the data in the transmit queue into 1460-byte chunks before passing the packets to the IP layer.

---

To configure per neighbor TCP MSS, use the **tcp mss** command under per neighbor, neighbor group or session group configuration.

For detailed configuration steps, see the *Configuring Per Neighbor TCP MSS* section.

For detailed steps to disable per neighbor TCP MSS, see the *Disabling Per Neighbor TCP MSS* section.

## BGP Keychains

BGP keychains enable keychain authentication between two BGP peers. The BGP endpoints must both comply with draft-bonica-tcp-auth-05.txt and a keychain on one endpoint and a password on the other endpoint does not work.

BGP is able to use the keychain to implement hitless key rollover for authentication. Key rollover specification is time based, and in the event of clock skew between the peers, the rollover process is impacted. The configurable tolerance specification allows for the accept window to be extended (before and after) by that margin. This accept window facilitates a hitless key rollover for applications (for example, routing and management protocols).

The key rollover does not impact the BGP session, unless there is a keychain configuration mismatch at the endpoints resulting in no common keys for the session traffic (send or accept).

## BGP Nonstop Routing

The Border Gateway Protocol (BGP) Nonstop Routing (NSR) with Stateful Switchover (SSO) feature enables all bgp peerings to maintain the BGP state and ensure continuous packet forwarding during events that could interrupt service. Under NSR, events that might potentially interrupt service are not visible to peer routers. Protocol sessions are not interrupted and routing states are maintained across process restarts and switchovers.

BGP NSR provides nonstop routing during the following events:

- Route processor switchover
- Process crash or process failure of BGP or TCP



---

**Note** BGP NSR is enabled by default. Use the **nsr disable** command to turn off BGP NSR. The **no nsr disable** command can also be used to turn BGP NSR back on if it has been disabled.

In case of process crash or process failure, NSR will be maintained only if **nsr process-failures switchover** command is configured. In the event of process failures of active instances, the **nsr process-failures switchover** configures failover as a recovery action and switches over to a standby route processor (RP) or a standby distributed route processor (DRP) thereby maintaining NSR. An example of the configuration command is `RP/0/RSP0/CPU0:router(config)# nsr process-failures switchover`

The **nsr process-failures switchover** command maintains both the NSR and BGP sessions in the event of a BGP or TCP process crash. Without this configuration, BGP neighbor sessions flap in case of a BGP or TCP process crash. This configuration does not help if the BGP or TCP process is restarted in which case the BGP neighbors are expected to flap.

When the *l2vpn\_mgr* process is restarted, the NSR client (te-control) flaps between the **Ready** and **Not Ready** state. This is the expected behavior and there is no traffic loss.

---

During route processor switchover and In-Service System Upgrade (ISSU), NSR is achieved by stateful switchover (SSO) of both TCP and BGP.

NSR does not force any software upgrades on other routers in the network, and peer routers are not required to support NSR.

When a route processor switchover occurs due to a fault, the TCP connections and the BGP sessions are migrated transparently to the standby route processor, and the standby route processor becomes active. The existing protocol state is maintained on the standby route processor when it becomes active, and the protocol state does not need to be refreshed by peers.

Events such as soft reconfiguration and policy modifications can trigger the BGP internal state to change. To ensure state consistency between active and standby BGP processes during such events, the concept of post-it is introduced that act as synchronization points.

BGP NSR provides the following features:

- NSR-related alarms and notifications

- Configured and operational NSR states are tracked separately
- NSR statistics collection
- NSR statistics display using **show** commands
- XML schema support
- Auditing mechanisms to verify state synchronization between active and standby instances
- CLI commands to enable and disable NSR
- Support for 5000 NSR sessions

## BGP Best-External Path

The best-external path functionality supports advertisement of the best-external path to the iBGP and Route Reflector peers when a locally selected bestpath is from an internal peer. BGP selects one best path and one backup path to every destination. By default, selects one best path. Additionally, BGP selects another bestpath from among the remaining external paths for a prefix. Only a single path is chosen as the best-external path and is sent to other PEs as the backup path. BGP calculates the best-external path only when the best path is an iBGP path. If the best path is an eBGP path, then best-external path calculation is not required.

The procedure to determine the best-external path is as follows:

1. Determine the best path from the entire set of paths available for a prefix.
2. Eliminate the current best path.
3. Eliminate all the internal paths for the prefix.
4. From the remaining paths, eliminate all the paths that have the same next hop as that of the current best path.
5. Rerun the best path algorithm on the remaining set of paths to determine the best-external path.

BGP considers the external and confederations BGP paths for a prefix to calculate the best-external path. BGP advertises the best path and the best-external path as follows:

- On the primary PE—advertises the best path for a prefix to both its internal and external peers
- On the backup PE—advertises the best path selected for a prefix to the external peers and advertises the best-external path selected for that prefix to the internal peers

## BGP Prefix Independent Convergence

BGP Prefix Independent Convergence (PIC) feature enables the activation of a backup path in the event of the primary path failure.

Networks use Fast reroute (FRR) to calculate the next best path (backup path) and store it in BGP and IP Routing Information Bases (RIBs). The RIBs share the backup path information with the Forwarding Information Base (FIB). BGP PIC feature uses the backup path information in the FIB to quickly switch to this path during network failure, provided the line cards are enabled for PIC.

### Drawbacks of Using Prefix-Dependent Convergence

In a standard BGP network, a BGP router advertises only its best path to a destination prefix. Hence, in an autonomous system, routers running BGP are not aware of all the possible paths to a destination prefix. In the event of a link or network failure that causes the best path to fail, the following process takes place:

1. The affected BGP router advertising the failed best path, announces a withdrawal of the path.
2. The BGP routers receiving the best path withdrawal from the affected BGP router, withdraw their own best paths, and recalculate their best paths to the destination prefix.
3. The BGP routers advertise their recalculated best paths to all neighboring routers.
4. Each BGP router that receives a new best path from its neighboring BGP router, again evaluates its own best path, and possibly withdraws and recalculates its best path.
5. The BGP routers that recalculate their best paths, again advertise the new paths in the network.

Because this process repeats until all the BGP routers have the best path to the destination prefix, convergence of the network takes a lot of time. This form of convergence is known as prefix-dependent convergence. If route reflectors are configured in the network, then convergence takes even longer.

### Benefits of Using Prefix-Independent Convergence

When prefix-independent convergence is configured in a BGP network, all BGP routers advertise their best external paths to a destination prefix. This indicates that all BGP routers are aware of multiple best external paths to a destination prefix.

Each BGP router selects a backup path from the available best external paths, and downloads it to its FIB. Hence, the FIB on each BGP router contains a best path and a best external path to a destination prefix. In the event of a link or network failure that causes the best path to fail, the FIB on the affected BGP router can switch all its routes using the failed path to the best external path, in a single operation. Because this form of convergence takes minimal time, it is preferred in large scale network deployments.

### Using Prefix-Independent Convergence with Route Reflectors

For traffic from the customer edge router to a remote provider edge router, the BGP `local-pref` attribute is used to select the primary path (from a primary PE) and the backup path (from the backup PE). Even though the remote provider edge router receives the backup (best external) path from the backup PE, when the backup PE receives the iBGP best path from the primary PE, it withdraws the backup path from the core network. Hence, the primary and backup (best external) paths must be pre-programmed in the network for PIC to work.

When the primary path fails, the delay in convergence is because of the following process that takes place:

1. The primary PE sends a request to the provider core network for withdrawing the primary path.
2. The backup PE advertises the backup (best external) path as the new primary (best) path.
3. The remote PE recalculates its primary paths on receiving the withdrawal request from the primary PE, and the new primary path from the backup PE.
4. Traffic resumes in the network after all prefixes in the FIB are updated with the new primary path.

Hence, convergence is slow because it depends on prefixes advertised by the PE routers.

By introducing prefix-independent convergence, the following changes take place:

- Primary and backup paths are pre-programmed in the RIB and FIB.

- All provider edge routers receive the backup path from the FIB.
- In the event of primary path failure, the FIB modifies LDIs to include the backup path and instantly divert traffic along this route.



**Note** To use BGP PIC feature with route reflectors, the provider edge routers must be configured with unique route distinguishers (RDs) within the context of a VRF. Else, the paths from different PEs are considered to be belonging to the same network, and the route reflector cannot accurately calculate the best backup path.

### Backup Path Selection Process

Use the following procedure to identify the best backup path to be programmed in the RIB and FIB.

1. Use the best path algorithm to identify the best path from the available set of paths for a prefix.
2. Eliminate the best path.
3. Eliminate all paths that have the same next hop as the best path.
4. Rerun the best path algorithm on the remaining set of paths to identify the best backup path.

## Configure BGP PIC in Provider Edge Networks

This section describes the procedure to configure BGP PIC for provider edge networks.

### Topology

Consider the topology shown in the following illustration.

**Figure 9: Prefix Independent Convergence in Provider Edge Networks**

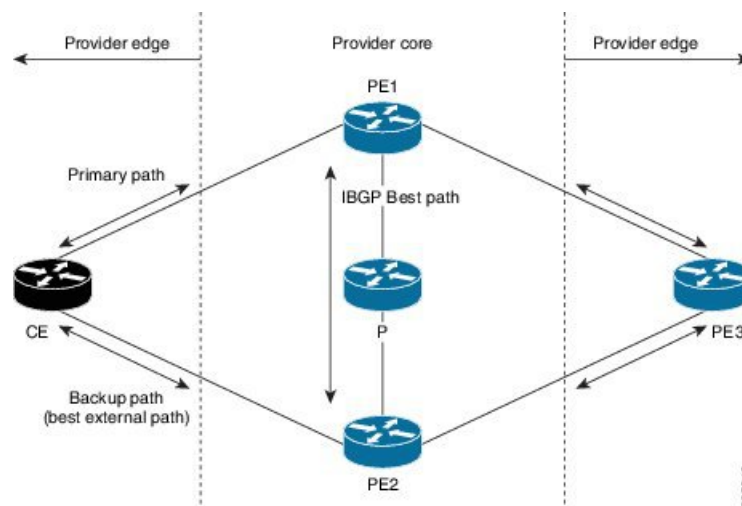

For traffic from the customer edge router CE to the provider edge router PE3, the BGP `local-pref` attribute is used to select CE-PE1-PE3 as the primary path, and CE-PE2-PE3 as the backup path. PE1-P-PE2 is the best internal path for the provider core network.

## Before you Begin

Before you can configure the BGP PIC feature, ensure that you have configured the following:

1. The loopback and network interfaces as per the topology.
2. The VRFs for the provider core network.

## Configuration

Use the configuration in this section to configure BGP PIC feature for the illustrated topology.

### Router PE1

For traffic from Router CE to Router PE3, the eBGP path from Router CE is stored as the primary path on Router PE1.

Configure Router PE1 to install the backup (best external) path advertised by Router PE2, and the period for which the local label must be retained on convergence, as shown.

```
Router(config)# router bgp 10
Router(config-bgp)# vrf foo
Router(config-bgp-vrf)# address-family ipv4 unicast
Router(config-bgp-vrf-af)# additional-path install
Router(config-bgp-vrf-af)# label-retention 10
```

### Router PE2

Configure Router PE2 to install and advertise the backup CE-PE2 path as the best external path.

```
Router(config)# router bgp 10
Router(config-bgp)# vrf foo
Router(config-bgp-vrf)# address-family ipv4 unicast
Router(config-bgp-vrf-af)# advertise-best-external label-alloc-mode
Router(config-bgp-vrf-af)# additional-path install
```

### Router PE3

The iBGP path from Router PE1 (CE-PE1) is stored as the primary path on Router PE3. Configure the iBGP backup path CE-PE2 as shown.

```
Router(config)# router bgp 10
Router(config-bgp)# vrf foo
Router(config-bgp-vrf)# address-family ipv4 unicast
Router(config-bgp-vrf-af)# additional-path install
```

## Verify BGP PIC

Run the following commands on Router PE3 to verify the BGP PIC feature in operation.

1. Verify the presence of the backup path in the FIB.

```
Router# show cef 1.1.1.1/32 detail
Fri Oct 10 10:24:33.079 UTC
1.1.1.1/32, version 1, internal 0x40000001 (0xa94c0574) [1], 0x0 (0x0), 0x0
(0x0)
Updated Oct 9 16:49:06.795
Prefix Len 32, traffic index 0, precedence routine (0)
gateway array (0xa8d9b130) reference count 4, flags 0x80200, source rib
(3),
[1 type 3 flags 0x901101 (0xa8ec6b90) ext 0x0 (0x0)]
LW-LDI[type=0, refc=0, ptr=0x0, sh-ldi=0x0]
Level 1 - Load distribution: 0
```



```

[0] via 12.24.0.1, recursive
via 12.24.0.1, 3 dependencies, recursive
next hop 12.24.0.1 via 12.24.0.1/32
via 12.24.0.2, 3 dependencies, recursive, backup
next hop 12.24.0.2 via 12.24.0.2/32
Load distribution: 0 (refcount 1)
Hash OK Interface Address
0 Y MgmtEth0/RP0/CPU0/0 12.24.0.1

```

## 2. Verify the presence of the backup (best external) path for BGP.

```

Router# show bgp vrf foo 206.1.1.1/32
BGP routing table entry for 206.1.1.1/32
Versions:
Process bRIB/RIB SendTblVer
Speaker 6 6
Local Label: 3
Paths: (1 available, best #1)
Advertised to peers (in unique update groups):
100.100.100.1
Path #1: Received by speaker 0
1.1.1.1 from 1.1.1.1 (200.200.200.1)
Origin incomplete, metric 0, localpref 100, weight 32768, valid,
internal, best
2.2.2.2 from 2.2.2.2 (100.100.100.1)
Origin incomplete, metric 0, localpref 100, weight 32768, valid,
external, backup, best-external

```

## Configure BGP PIC between Autonomous Systems

This section describes the procedure to configure BGP PIC between autonomous systems. .



**Note** BGP PIC is supported only for Option A and Option B scenarios. The following section describes a sample configuration for Option B.

### Topology

For example, consider the topology shown in the following illustration.

**Figure 10: Prefix-Independent Convergence between Autonomous Systems**

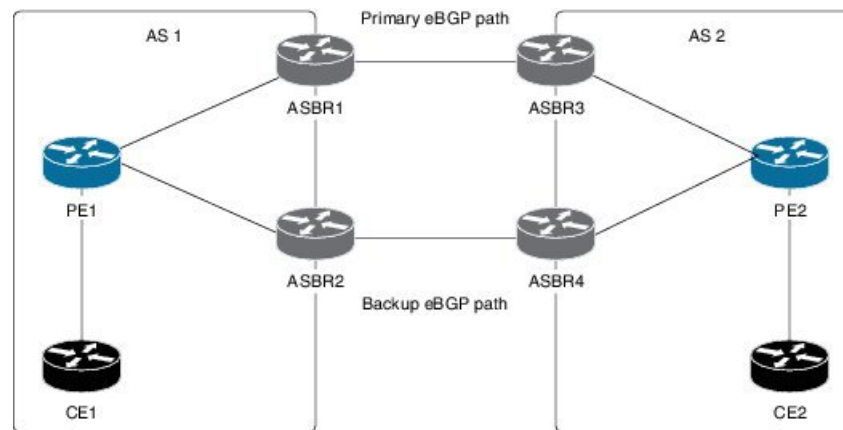

For traffic from Router PE1 to Router PE2, ASBR1 is the primary router and ASBR2 is the backup router. The ASBR1-ASBR3 eBGP path is the primary path. The ASBR2-ASBR4 eBGP path is the backup path. For traffic from Router PE2 to Router PE1, ASBR3 is the primary router and ASBR4 is the backup router. The ASBR3-ASBR1 eBGP path is the primary path and the ASBR4-ASBR2 eBGP path is the backup path.

### Before you Begin

Before you can configure the BGP PIC feature, ensure that you have configured the loopback and network interfaces as per the illustrated topology.

### Configuration

Use the configuration in this section to configure BGP PIC feature for the illustrated topology.

#### Router ASBR1

Configure Router ASBR1 to install the backup (best external) path advertised by Router ASBR2, and the period for which the local label must be retained on convergence, as shown.

```
Router(config)# router bgp 10
Router(config-bgp)# address-family vpnv4 unicast
Router(config-bgp-af)# additional-path install
Router(config-bgp-af)# label-retention 10
```

The provided configuration is for traffic from Router PE1 to Router PE2. Similarly, configure Router ASBR3 for traffic from Router PE2 to Router PE1.

#### Router ASBR2

Configure Router ASBR2 to install and advertise the ASBR2-ASBR4 backup (best external) path, as shown.

```
Router(config)# router bgp 10
Router(config-bgp)# address-family vpnv4 unicast
Router(config-bgp-af)# advertise-best-external label-alloc-mode
Router(config-bgp-af)# additional-path install
```

The provided configuration is for traffic from Router PE1 to Router PE2. Similarly, configure Router ASBR4 for traffic from Router PE2 to Router PE1.

### Verify BGP PIC

Run the following commands on Router PE2 (for traffic from Router PE1 to Router PE2) or on Router PE1 (for traffic from Router PE2 to Router PE1) to verify the BGP PIC feature in operation.

1. Verify the presence of the backup path in the FIB.

```
Router# show cef 1.1.1.1/32 detail

Fri Oct 10 10:24:33.079 UTC
1.1.1.1/32, version 1, internal 0x40000001 (0xa94c0574) [1], 0x0 (0x0), 0x0
(0x0)
Updated Oct 9 16:49:06.795
Prefix Len 32, traffic index 0, precedence routine (0)
gateway array (0xa8d9b130) reference count 4, flags 0x80200, source rib
(3),
[1 type 3 flags 0x901101 (0xa8ec6b90) ext 0x0 (0x0)]
LW-LDI[type=0, refc=0, ptr=0x0, sh-ldi=0x0]
Level 1 - Load distribution: 0
[0] via 12.24.0.1, recursive
via 12.24.0.1, 3 dependencies, recursive
```

```

next hop 12.24.0.1 via 12.24.0.1/32
via 12.24.0.2, 3 dependencies, recursive, backup
next hop 12.24.0.2 via 12.24.0.2/32
Load distribution: 0 (refcount 1)
Hash OK Interface Address
0 Y MgmtEth0/RP0/CPU0/0 12.24.0.1

```

## 2. Verify the presence of the backup (best external) path for BGP.

```

Router# show bgp vrf foo 206.1.1.1/32

BGP routing table entry for 206.1.1.1/32
Versions:
Process bRIB/RIB SendTblVer
Speaker 6 6
Local Label: 3
Paths: (1 available, best #1)
Advertised to peers (in unique update groups):
100.100.100.1
Path #1: Received by speaker 0
1.1.1.1 from 1.1.1.1 (200.200.200.1)
Origin incomplete, metric 0, localpref 100, weight 32768, valid,
internal, best
2.2.2.2 from 2.2.2.2 (100.100.100.1)
Origin incomplete, metric 0, localpref 100, weight 32768, valid,
external, backup, best-external

```

## Command Line Interface (CLI) Consistency for BGP Commands

The Border Gateway Protocol (BGP) commands use **disable** keyword to disable a feature. The keyword **inheritance-disable** disables the inheritance of the feature properties from the parent level.

## BGP Additional Paths

*Table 5: Feature History Table*

Feature Name	Release Information	Feature Description
Additional path control per neighbor	Release 7.3.15	<p>This feature allows flexibility and granular control of the advertisement of additional paths based on the neighbor outbound policy configuration.</p> <p>This is done by allowing configuration of combinations of different path selection procedures unlike singular path selection, and extending neighbor outbound policy to have finer control of the path types to be advertised.</p> <p>This feature enables operational efficiency to manage additional paths and reduce scale of the paths in a typical clustered network architecture.</p> <p>Without this feature, the path scale limitation of the memory is impacted, and control plane convergence issues develop because of the excessive number of paths.</p>

The Border Gateway Protocol (BGP) Additional Paths feature modifies the BGP protocol machinery for a BGP speaker to be able to send multiple paths for a prefix. This gives 'path diversity' in the network. The add path enables BGP prefix independent convergence (PIC) at the edge routers.

BGP add path enables add path advertisement in an iBGP network and advertises the following types of paths for a prefix:

- Backup paths—to enable fast convergence and connectivity restoration.
- Group-best paths—to resolve route oscillation.
- All paths—to emulate an iBGP full-mesh.

## iBGP Multipath Load Sharing

When a Border Gateway Protocol (BGP) speaking router that has no local policy configured, receives multiple network layer reachability information (NLRI) from the internal BGP (iBGP) for the same destination, the router will choose one iBGP path as the best path. The best path is then installed in the IP routing table of the router. The iBGP Multipath Load Sharing feature enables the BGP speaking router to select multiple iBGP paths as the best paths to a destination. The best paths or multipaths are then installed in the IP routing table of the router.

### Configure iBGP Multipath Load Sharing

Perform this task to configure the iBGP Multipath Load Sharing:

#### SUMMARY STEPS

1. **configure**
2. **router bgp** *as-number*
3. **address-family** {*ipv4|ipv6*} {*unicast|multicast*}
4. **maximum-paths** **ibgp** *number*
5. Use the **commit** or **end** command.

#### DETAILED STEPS

---

**Step 1**    **configure****Example:**

```
RP/0/# configure
Enters mode.
```

**Step 2**    **router bgp** *as-number***Example:**

```
Router(config)# router bgp 100
```

Specifies the autonomous system number and enters the BGP configuration mode, allowing you to configure the BGP routing process.

**Step 3**    **address-family** {*ipv4|ipv6*} {*unicast|multicast*}

**Example:**

```
Router(config-bgp)# address-family ipv4 multicast
```

Specifies either the IPv4 or IPv6 address family and enters address family configuration submode.

**Step 4** `maximum-paths ibgp number`**Example:**

```
Router(config-bgp-af)# maximum-paths ibgp 30
```

Configures the maximum number of iBGP paths for load sharing.

**Step 5** Use the `commit` or `end` command.

**commit** —Saves the configuration changes and remains within the configuration session.

**end** —Prompts user to take one of these actions:

- **Yes** — Saves configuration changes and exits the configuration session.
- **No** —Exits the configuration session without committing the configuration changes.
- **Cancel** —Remains in the configuration session, without committing the configuration changes.

**iBGP Multipath Loadsharing Configuration: Example**

The following is a sample configuration where 30 paths are used for loadsharing:

```
router bgp 100
 address-family ipv4 multicast
   maximum-paths ibgp 30
 !
end
```

## Accumulated IGP Attribute for BGP

*Table 6: Feature History Table*

Feature Name	Release Information	Feature Description
Accumulated IGP Attribute for BGP	Release 7.3.2	This feature enables you to implement multiple contiguous BGP Autonomous Systems under a single administration.  You can allow BGP to make its routing decisions based on the IGP metric just as an IGP would do.

**Overview of BGP AIGP**

The Accumulated IGP (AIGP) Attribute for BGP is an optional non-transitive BGP path Attribute. IANA assigned the attribute type code for the AIGP attribute. The value field of the AIGP attribute is defined as a set of Type/Length/Value elements (TLVs). The AIGP TLV contains the Accumulated IGP metric.

The AIGP feature is required in the network to simulate the current OSPF behavior of computing the distance associated with a path. OSPF or LDP carries the prefix or label information only in the local area. Then, BGP carries the prefix label to all the remote areas by redistributing the routes into BGP at area boundaries. The routes or labels are then advertised using LSPs. The next hop for the route is changed at each ABR to local router which removes the need to leak OSPF routes across area boundaries. The bandwidth available on each of the core links is mapped to OSPF cost, hence it is imperative that BGP carries this cost correctly between each of the PEs. This functionality is achieved by using the AIGP.

### Originate Prefixes with AIGP

Origination of routes with the accumulated interior gateway protocol (AIGP) metric is controlled by configuration. AIGP attributes are attached to redistributed routes that satisfy following conditions.

- The protocol redistributing the route is enabled for AIGP.
- The route is an interior gateway protocol (IGP) route redistributed into border gateway protocol (BGP). The value assigned to the AIGP attribute is the value of iGP next hop to the route or as set by a route-policy.
- The route is a static route redistributed into BGP. The value assigned is the value of next hop to the route or as set by a route-policy.
- The route is imported into BGP through network statement. The value assigned is the value of next hop to the route or as set by a route-policy.

### Configuration Examples

Originate prefixes with AIGP.

```
Router(config)# route-policy aip_policy
Router(config-rpl)# set aigp-metric igp-cost
Router(config-rpl)# exit
Router(config)# router bgp 100
Router(config-bgp)# address-family ipv4 unicast
Router(config-bgp-af)# redistribute ospf route-policy aip_policy
```

### Running Configuration

```
route-policy aip_policy
  set aigp-metric igp-cost
!
router bgp 100
  address-family ipv4 unicast
    redistribute ospf route-policy aip_policy
```

### Verification

Verify the status of the AIGP attribute.

```
Router# show bgp 10.0.0.1
Thu Sep 30 21:21:15.279 EDT
BGP routing table entry for 10.0.0.1/32
Versions:
Process bRIB/RIB SendTblVer
Speaker 4694 4694
Last Modified: Sep 30 21:20:09.000 for 00:01:06
```

```

Paths: (2 available, best #1)
Not advertised to any peer
Path #1: Received by speaker 0
Not advertised to any peer
Local
192.168.0.1 (metric 2) from 192.168.0.1 (192.168.0.6)
Received Label 24000
Origin IGP, localpref 80, aigp metric 900, valid, internal, best, group-best, labeled-unicast
Received Path ID 1, Local Path ID 1, version 4694
Originator: 192.168.0.6, Cluster list: 192.168.0.1
Total AIGP metric 902 <-- AIGP attribute received.

```

## Accumulated Interior Gateway Protocol Attribute

The Accumulated Interior Gateway Protocol (AiGP) Attribute is an optional non-transitive BGP Path Attribute. The attribute type code for the AiGP Attribute is to be assigned by IANA. The value field of the AiGP Attribute is defined as a set of Type/Length/Value elements (TLVs). The AiGP TLV contains the Accumulated IGP Metric.

The AiGP feature is required in the 3107 network to simulate the current OSPF behavior of computing the distance associated with a path. OSPF/LDP carries the prefix/label information only in the local area. Then, BGP carries the prefix/label to all the remote areas by redistributing the routes into BGP at area boundaries. The routes/labels are then advertised using LSPs. The next hop for the route is changed at each ABR to local router which removes the need to leak OSPF routes across area boundaries. The bandwidth available on each of the core links is mapped to OSPF cost, hence it is imperative that BGP carries this cost correctly between each of the PEs. This functionality is achieved by using the AiGP.

## BGP Accept Own

The BGP Accept Own feature enables handling of self-originated VPN routes, which a BGP speaker receives from a route-reflector (RR). A "self-originated" route is one which was originally advertised by the speaker itself. As per BGP protocol [RFC4271], a BGP speaker rejects advertisements that were originated by the speaker itself. However, the BGP Accept Own mechanism enables a router to accept the prefixes it has advertised, when reflected from a route-reflector that modifies certain attributes of the prefix. A special community called ACCEPT-OWN is attached to the prefix by the route-reflector, which is a signal to the receiving router to bypass the ORIGINATOR\_ID and NEXTHOP/MP\_REACH\_NLRI check. Generally, the BGP speaker detects prefixes that are self-originated through the self-origination check (ORIGINATOR\_ID, NEXTHOP/MP\_REACH\_NLRI) and drops the received updates. However, with the Accept Own community present in the update, the BGP speaker handles the route.

One of the applications of BGP Accept Own is auto-configuration of extranets within MPLS VPN networks. In an extranet configuration, routes present in one VRF is imported into another VRF on the same PE. Normally, the extranet mechanism requires that either the import-rt or the import policy of the extranet VRFs be modified to control import of the prefixes from another VRF. However, with Accept Own feature, the route-reflector can assert that control without the need for any configuration change on the PE. This way, the Accept Own feature provides a centralized mechanism for administering control of route imports between different VRFs.

BGP Accept Own is supported only for VPNv4 and VPNv6 address families in neighbor configuration mode.

### Route-Reflector Handling Accept Own Community and RTs

The ACCEPT\_OWN community is originated by the InterAS route-reflector (InterAS-RR) using an outbound route-policy. To minimize the propagation of prefixes with the ACCEPT\_OWN community attribute, the attribute will be attached on the InterAS-RR using an outbound route-policy towards the originating PE. The

InterAS-RR adds the ACCEPT-OWN community and modifies the set of RTs before sending the new Accept Own route to the attached PEs, including the originator, through intervening RRs. The route is modified via route-policy.

### Accept Own Configuration Example

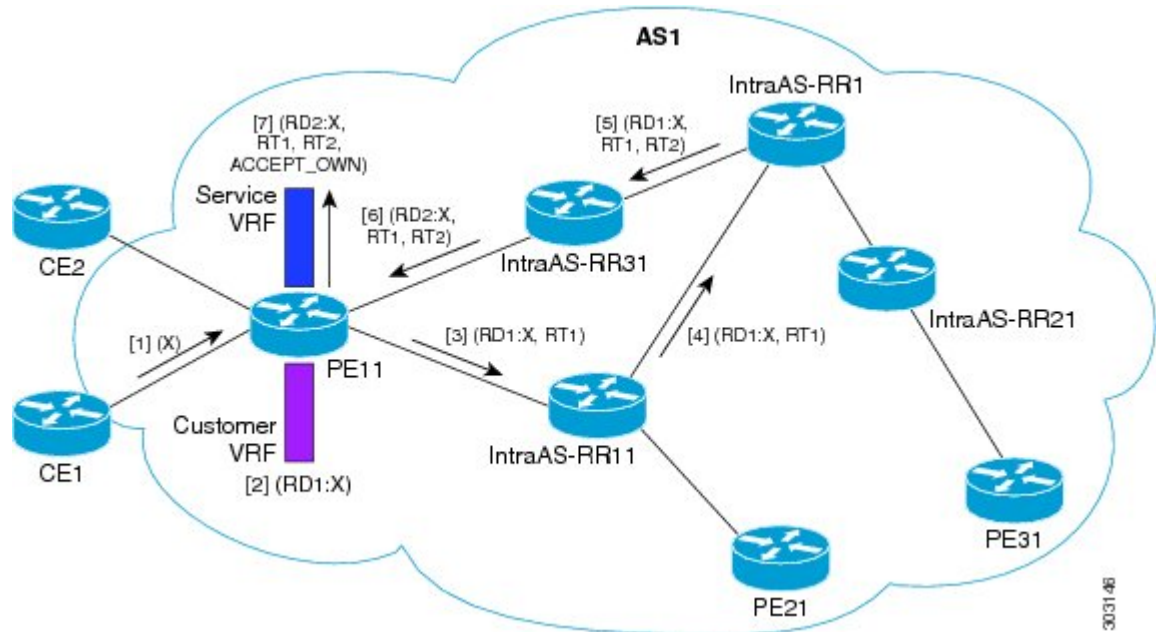

In this configuration example:

- PE11 is configured with Customer VRF and Service VRF.
- OSPF is used as the IGP.
- VPNv4 unicast and VPNv6 unicast address families are enabled between the PE and RR neighbors and IPv4 and IPv6 are enabled between PE and CE neighbors.

The Accept Own configuration works as follows:

1. CE1 originates prefix X.
2. Prefix X is installed in customer VRF as (RD1:X).
3. Prefix X is advertised to IntraAS-RR11 as (RD1:X, RT1).
4. IntraAS-RR11 advertises X to InterAS-RR1 as (RD1:X, RT1).
5. InterAS-RR1 attaches RT2 to prefix X on the inbound and ACCEPT\_OWN community on the outbound and advertises prefix X to IntraAS-RR31.
6. IntraAS-RR31 advertises X to PE11.
7. PE11 installs X in Service VRF as (RD2:X,RT1, RT2, ACCEPT\_OWN).



### Remote PE: Handling of Accept Own Routes

Remote PEs (PEs other than the originator PE), performs bestpath calculation among all the comparable routes. The bestpath algorithm has been modified to prefer an Accept Own path over non-Accept Own path. The bestpath comparison occurs immediately before the IGP metric comparison. If the remote PE receives an Accept Own path from route-reflector 1 and a non-Accept Own path from route-reflector 2, and if the paths are otherwise identical, the Accept Own path is preferred. The import operates on the Accept Own path.

## Configuring BGP Accept Own

Perform this task to configure BGP Accept Own:

### SUMMARY STEPS

1. **configure**
2. **router bgp** *as-number*
3. **neighbor** *ip-address*
4. **remote-as** *as-number*
5. **update-source** *type interface-path-id*
6. **address-family** {*vpn4 unicast* | *vpn6 unicast*}
7. **accept-own** [**inheritance-disable**]

### DETAILED STEPS

	Command or Action	Purpose
Step 1	<b>configure</b> <b>Example:</b> RP/0/# configure	Enters mode.
Step 2	<b>router bgp</b> <i>as-number</i> <b>Example:</b> Router(config)#router bgp 100	Specifies the autonomous system number and enters the BGP configuration mode, allowing you to configure the BGP routing process.
Step 3	<b>neighbor</b> <i>ip-address</i> <b>Example:</b> Router(config-bgp)#neighbor 10.1.2.3	Places the router in neighbor configuration mode for BGP routing and configures the neighbor IP address as a BGP peer.
Step 4	<b>remote-as</b> <i>as-number</i> <b>Example:</b> Router(config-bgp-nbr)#remote-as 100	Assigns a remote autonomous system number to the neighbor.
Step 5	<b>update-source</b> <i>type interface-path-id</i> <b>Example:</b> Router(config-bgp-nbr)#update-source Loopback0	Allows sessions to use the primary IP address from a specific interface as the local address when forming a session with a neighbor.
Step 6	<b>address-family</b> { <i>vpn4 unicast</i>   <i>vpn6 unicast</i> } <b>Example:</b>	Specifies the address family as VPNv4 or VPNv6 and enters neighbor address family configuration mode.

	Command or Action	Purpose
	<code>Router(config-bgp-nbr)#address-family vpnv6 unicast</code>	
<b>Step 7</b>	<p><b>accept-own [inheritance-disable]</b></p> <p><b>Example:</b></p> <pre>Router(config-bgp-nbr-af)#accept-own</pre>	<p>Enables handling of self-originated VPN routes containing Accept_Own community.</p> <p>Use the <b>inheritance-disable</b> keyword to disable the "accept own" configuration and to prevent inheritance of "acceptown" from a parent configuration.</p>

## BGP Link-State

BGP Link-State (LS) is an Address Family Identifier (AFI) and Sub-address Family Identifier (SAFI) originally defined to carry interior gateway protocol (IGP) link-state information through BGP. The BGP Network Layer Reachability Information (NLRI) encoding format for BGP-LS and a new BGP Path Attribute called the BGP-LS attribute are defined in [RFC7752](#). The identifying key of each Link-State object, namely a node, link, or prefix, is encoded in the NLRI and the properties of the object are encoded in the BGP-LS attribute.





---

**Note** IGP's do not use BGP LS data from remote peers. BGP does not download the received BGP LS data to any other component on the router.

---

An example of a BGP-LS application is the Segment Routing Path Computation Element (SR-PCE). The SR-PCE can learn the SR capabilities of the nodes in the topology and the mapping of SR segments to those nodes. This can enable the SR-PCE to perform path computations based on SR-TE and to steer traffic on paths different from the underlying IGP-based distributed best-path computation.

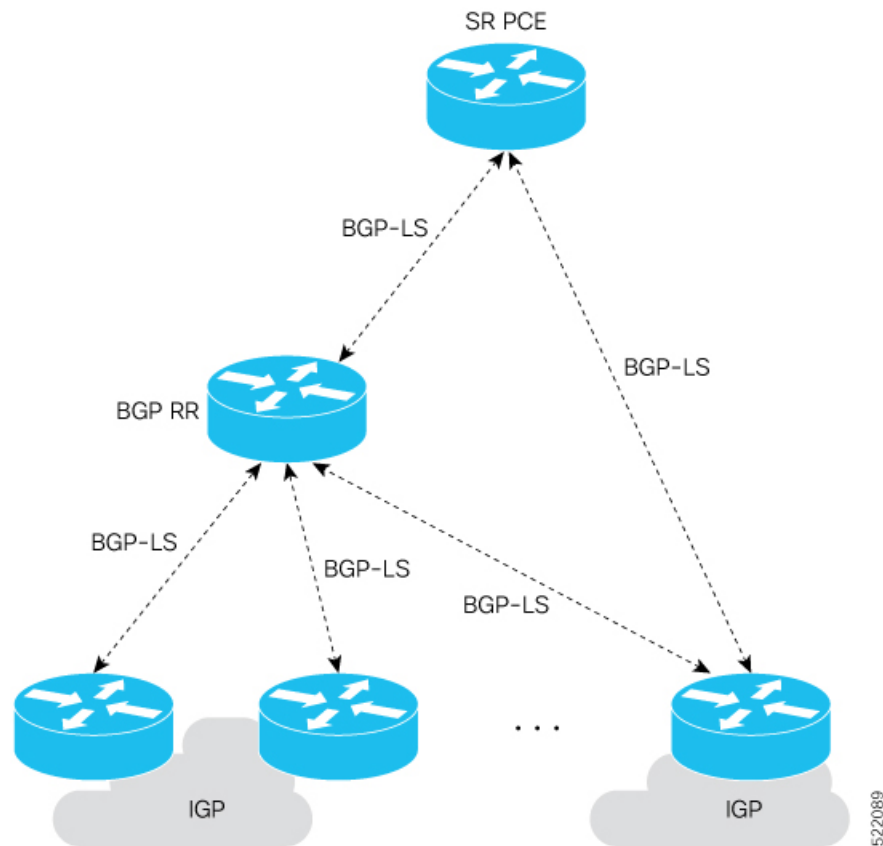
The following figure shows a typical deployment scenario. In each IGP area, one or more nodes (BGP speakers) are configured with BGP-LS. These BGP speakers form an iBGP mesh by connecting to one or more route-reflectors. This way, all BGP speakers (specifically the route-reflectors) obtain Link-State information from all IGP areas (and from other ASes from eBGP peers).



### Exchange Link State Information with BGP Neighbor

The following example shows how to exchange link-state information with a BGP neighbor:

```
Router# configure
Router(config)# router bgp 1
Router(config-bgp)# neighbor 10.0.0.2
Router(config-bgp-nbr)# remote-as 1
Router(config-bgp-nbr)# address-family link-state link-state
Router(config-bgp-nbr-af)# exit
```

### IGP Link-State Database Distribution

A given BGP node may have connections to multiple, independent routing domains. IGP link-state database distribution into BGP-LS is supported for both OSPF and IS-IS protocols in order to distribute this information on to controllers or applications that desire to build paths spanning or including these multiple domains.

To distribute OSPFv2 link-state data using BGP-LS, use the **distribute link-state** command in router configuration mode.

```
Router# configure
Router(config)# router ospf 100
Router(config-ospf)# distribute link-state instance-id 32
```

### Usage Guidelines and Limitations

- BGP-LS supports IS-IS and OSPFv2.
- The identifier field of BGP-LS (referred to as the Instance-ID) identifies the IGP routing domain where the NLRI belongs. The NRIs representing link-state objects (nodes, links, or prefixes) from the same IGP routing instance must use the same Instance-ID value.
- When there is only a single protocol instance in the network where BGP-LS is operational, we recommend configuring the Instance-ID value to **0**.
- Assign consistent BGP-LS Instance-ID values on all BGP-LS Producers within a given IGP domain.
- NRIs with different Instance-ID values are considered to be from different IGP routing instances.
- Unique Instance-ID values must be assigned to routing protocol instances operating in different IGP domains. This allows the BGP-LS Consumer (for example, SR-PCE) to build an accurate segregated multi-domain topology based on the Instance-ID values, even when the topology is advertised via BGP-LS by multiple BGP-LS Producers in the network.
- If the BGP-LS Instance-ID configuration guidelines are not followed, a BGP-LS Consumer may see duplicate link-state objects for the same node, link, or prefix when there are multiple BGP-LS Producers deployed. This may also result in the BGP-LS Consumers getting an inaccurate network-wide topology.

## Configuring BGP Link-state

To exchange BGP link-state (LS) information with a BGP neighbor, perform these steps:

---

**Step 1** **configure****Example:**

```
RP/0/# configure
```

Enters mode.

**Step 2** **router bgp** *as-number***Example:**

```
Router(config)# router bgp 100
```

Specifies the BGP AS number and enters the BGP configuration mode, allowing you to configure the BGP routing process.

**Step 3** **neighbor** *ip-address***Example:**

```
Router(config-bgp)# neighbor 10.0.0.2
```

Configures a CE neighbor. The ip-address argument must be a private address.

**Step 4** **remote-as** *as-number*

**Example:**

```
Router(config-bgp-nbr)# remote-as 1
```

Configures the remote AS for the CE neighbor.

**Step 5** **address-family link-state link-state****Example:**

```
Router(config-bgp-nbr)# address-family link-state link-state
```

Distributes BGP link-state information to the specified neighbor.

**Step 6** Use the **commit** or **end** command.

**commit**—Saves the configuration changes and remains within the configuration session.

**end**—Prompts user to take one of these actions:

- **Yes** — Saves configuration changes and exits the configuration session.
- **No** —Exits the configuration session without committing the configuration changes.
- **Cancel** —Remains in the configuration session, without committing the configuration changes.

---

## Configuring Domain Distinguisher

To configure unique identifier four-octet ASN, perform these steps:

---

**Step 1** **configure****Example:**

```
RP/0/# configure
```

Enters mode.

**Step 2** **router bgp** *as-number***Example:**

```
Router(config)# router bgp 100
```

Specifies the BGP AS number and enters the BGP configuration mode, allowing you to configure the BGP routing process.

**Step 3** **address-family link-state link-state****Example:**

```
Router(config-bgp)# address-family link-state link-state
```

Enters address-family link-state configuration mode.

**Step 4** `domain-distinguisher` *unique-id***Example:**

```
Router(config-bgp-af)# domain-distinguisher 1234
```

Configures unique identifier four-octet ASN. Range is from 1 to 4294967295.

**Step 5** Use the `commit` or `end` command.

**commit** —Saves the configuration changes and remains within the configuration session.

**end** —Prompts user to take one of these actions:

- **Yes** — Saves configuration changes and exits the configuration session.
- **No** —Exits the configuration session without committing the configuration changes.
- **Cancel** —Remains in the configuration session, without committing the configuration changes.

---

## BGP Permanent Network

BGP permanent network feature supports static routing through BGP. BGP routes to IPv4 or IPv6 destinations (identified by a route-policy) can be administratively created and selectively advertised to BGP peers. These routes remain in the routing table until they are administratively removed. A permanent network is used to define a set of prefixes as permanent, that is, there is only one BGP advertisement or withdrawal in upstream for a set of prefixes. For each network in the prefix-set, a BGP permanent path is created and treated as less preferred than the other BGP paths received from its peer. The BGP permanent path is downloaded into RIB when it is the best-path.

The **permanent-network** command in global address family configuration mode uses a route-policy to identify the set of prefixes (networks) for which permanent paths is to be configured. The **advertise permanent-network** command in neighbor address-family configuration mode is used to identify the peers to whom the permanent paths must be advertised. The permanent paths is always advertised to peers having the advertise permanent-network configuration, even if a different best-path is available. The permanent path is not advertised to peers that are not configured to receive permanent path.

The permanent network feature supports only prefixes in IPv4 unicast and IPv6 unicast address-families under the default Virtual Routing and Forwarding (VRF).

### Restrictions

These restrictions apply while configuring the permanent network:

- Permanent network prefixes must be specified by the route-policy on the global address family.
- You must configure the permanent network with route-policy in global address family configuration mode and then configure it on the neighbor address family configuration mode.
- When removing the permanent network configuration, remove the configuration in the neighbor address family configuration mode and then remove it from the global address family configuration mode.

## Configuring BGP Permanent Network

Perform this task to configure BGP permanent network. You must configure at least one route-policy to identify the set of prefixes (networks) for which the permanent network (path) is to be configured.

---

**Step 1**     **configure****Example:**

```
RP/0/# configure
Enters mode.
```

**Step 2**     **prefix-set** *prefix-set-name***Example:**

```
Router(config)# prefix-set PERMANENT-NETWORK-IPv4
Router(config-pfx)# 1.1.1.1/32,
Router(config-pfx)# 2.2.2.2/32,
Router(config-pfx)# 3.3.3.3/32
Router(config-pfx)# end-set
```

Enters prefix set configuration mode and defines a prefix set for contiguous and non-contiguous set of bits.

**Step 3**     **exit****Example:**

```
Router(config-pfx)# exit
```

Exits prefix set configuration mode and enters global configuration mode.

**Step 4**     **route-policy** *route-policy-name***Example:**

```
Router(config)# route-policy POLICY-PERMANENT-NETWORK-IPv4
Router(config-rpl)# if destination in PERMANENT-NETWORK-IPv4 then
Router(config-rpl)# pass
Router(config-rpl)# endif
```

Creates a route policy and enters route policy configuration mode, where you can define the route policy.

**Step 5**     **end-policy****Example:**

```
Router(config-rpl)# end-policy
```

Ends the definition of a route policy and exits route policy configuration mode.

**Step 6**     **router bgp** *as-number***Example:**

```
Router(config)# router bgp 100
```

Specifies the autonomous system number and enters the BGP configuration mode.

**Step 7** **address-family { ipv4 | ipv6 } unicast**

**Example:**

```
Router(config-bgp)# address-family ipv4 unicast
```

Specifies either an IPv4 or IPv6 address family unicast and enters address family configuration submode.

**Step 8** **permanent-network route-policy route-policy-name**

**Example:**

```
Router(config-bgp-af)# permanent-network route-policy POLICY-PERMANENT-NETWORK-IPv4
```

Configures the permanent network (path) for the set of prefixes as defined in the route-policy.

**Step 9** Use the **commit** or **end** command.

**commit** —Saves the configuration changes and remains within the configuration session.

**end** —Prompts user to take one of these actions:

- **Yes** — Saves configuration changes and exits the configuration session.
- **No** —Exits the configuration session without committing the configuration changes.
- **Cancel** —Remains in the configuration session, without committing the configuration changes.

**Step 10** **show bgp { ipv4 | ipv6 } unicast prefix-set**

**Example:**

```
show bgp ipv4 unicast
```

(Optional) Displays whether the prefix-set is a permanent network in BGP.

## Advertise Permanent Network

Perform this task to identify the peers to whom the permanent paths must be advertised.

**Step 1** **configure**

**Example:**

```
RP/0/# configure
```

Enters mode.



**Step 2** `router bgp as-number`**Example:**

```
Router(config)# router bgp 100
```

Specifies the autonomous system number and enters the BGP configuration mode.

**Step 3** `neighbor ip-address`**Example:**

```
Router(config-bgp)# neighbor 10.255.255.254
```

Places the router in neighbor configuration mode for BGP routing and configures the neighbor IP address as a BGP peer.

**Step 4** `remote-as as-number`**Example:**

```
Router(config-bgp-nbr)# remote-as 4713
```

Assigns the neighbor a remote autonomous system number.

**Step 5** `address-family { ipv4 | ipv6 } unicast`**Example:**

```
Router(config-bgp-nbr)# address-family ipv4 unicast
```

Specifies either an IPv4 or IPv6 address family unicast and enters address family configuration submode.

**Step 6** `advertise permanent-network`**Example:**

```
Router(config-bgp-nbr-af)# advertise permanent-network
```

Specifies the peers to whom the permanent network (path) is advertised.

**Step 7** Use the **commit** or **end** command.

**commit** —Saves the configuration changes and remains within the configuration session.

**end** —Prompts user to take one of these actions:

- **Yes** — Saves configuration changes and exits the configuration session.
- **No** —Exits the configuration session without committing the configuration changes.
- **Cancel** —Remains in the configuration session, without committing the configuration changes.

**Step 8** `show bgp { ipv4 | ipv6 } unicast neighbor ip-address`**Example:**

```
Router# show bgp ipv4 unicast neighbor 10.255.255.254
```

(Optional) Displays whether the neighbor is capable of receiving BGP permanent networks.

---

## BGP-RIB Feedback Mechanism for Update Generation

The Border Gateway Protocol-Routing Information Base (BGP-RIB) feedback mechanism for update generation feature avoids premature route advertisements and subsequent packet loss in a network. This mechanism ensures that routes are installed locally, before they are advertised to a neighbor.

BGP waits for feedback from RIB indicating that the routes that BGP installed in RIB are installed in forwarding information base (FIB) before BGP sends out updates to the neighbors. RIB uses the the BCDL feedback mechanism to determine which version of the routes have been consumed by FIB, and updates the BGP with that version. BGP will send out updates of only those routes that have versions up to the version that FIB has installed. This selective update ensures that BGP does not send out premature updates resulting in attracting traffic even before the data plane is programmed after router reload, LC OIR, or flap of a link where an alternate path is made available.

To configure BGP to wait for feedback from RIB indicating that the routes that BGP installed in RIB are installed in FIB, before BGP sends out updates to neighbors, use the **update wait-install** command in router address-family IPv4 or router address-family VPNv4 configuration mode. The **show bgp**, **show bgp neighbors**, and **show bgp process performance-statistics** commands display the information from update wait-install configuration.

## Default-originate Under VRF

BGP advertises default routes to provider-edge neighbors, based on per-VRF configuration.

## User-Defined Martian Address Check

When you configure BGP on a Cisco 8000 Series Router, you can prevent routers from accessing certain sites with certain IP address prefixes. These routers drop packets from such IP addresses, and such IP addresses are known as Martian addresses. However, you can enable routers with BGP IPv4 address-family or BGP IPv6 address-family configuration to access these sites by configuring the command **default-martian-check disable**. These sites are sites with certain IPv4 and IPv6 prefixes as follows:

- IPv4 address prefixes
  - 0.0.0.0/8
  - 127.0.0.0/8
  - 224.0.0.0/4
  
- IPv6 address prefixes
  - ::
  - ::0002 - ::ffff
  - ::ffff:a.b.c.d
  - fe80:xxxx
  - ffxx:xxxx

## Restrictions

Routers with OSPF or IS-IS Protocols cannot access these sites even by having the **default-martian-check disable** command configured.

## Configuration Example

To allow routes from Martian addresses, use the following steps:

1. Enter BGP IPv4 or BGP IPv6 address-family configuration mode.
2. Configure the address-family modifier as a unicast address.
3. Disable the Martian address check.

## Configuration

```
/* Enter BGP IPv4 or BGP IPv6 address-family configuration mode. */
Router# configure
Router(config)# router bgp 100

/* Configure the address-family modifier as unicast. */
Router(config-bgp)# address-family ipv4 unicast

/* Disable the martian address check. */
Router(config-bgp-af)# default-martian-check disable
Router(config-bgp-af)# commit
```

## Verification

To verify if you have enabled or disabled a Martian address check, you can use the **show bgp ipv4 unicast** command or **show bgp ipv6 unicast** command:

```
Router# show bgp ipv6 unicast
BGP router identifier 2.2.2.1, local AS number 1
BGP generic scan interval 60 secs
Non-stop routing is enabled
BGP table state: Active
Table ID: 0xe0800000 RD version: 29
BGP main routing table version 29
BGP NSR Initial initsync version 4 (Reached)
BGP NSR/ISSU Sync-Group versions 0/0
Dampening enabled
BGP scan interval 60 secs

Status codes: s suppressed, d damped, h history, * valid, > best
i - internal, r RIB-failure, S stale, N Nexthop-discard
Origin codes: i - IGP, e - EGP, ? - incomplete
Network          Next Hop          Metric   LocPrf   Weight Path
*>i::/0          1:1:1:1:1:1:1:1  100      0        0      i
* i192:1::/112   1.1.1.1           0        100      0      ?
*>i             1:1:1:1:1:1:1:1  0        100      0      ?
* iff11:1123::/64 1.1.1.1           2        100      0      ?
*>i             1:1:1:1:1:1:1:1  2        100      0      ?
```

# BGP Multipath Enhancements

- Overwriting of next-hop calculation for multipath prefixes is not allowed. The **next-hop-unchanged multipath** command disables overwriting of next-hop calculation for multipath prefixes.

- The ability to ignore as-path onwards while computing multipath is added. The **bgp multipath as-path ignore onwards** command ignores as-path onwards while computing multipath.

When multiple connected routers start ignoring as-path onwards while computing multipath, it causes routing loops. Therefore, you should not configure the **bgp multipath as-path ignore onwards** command on routers that can form a loop.

*Figure 11: Topology to illustrate formation of loops*

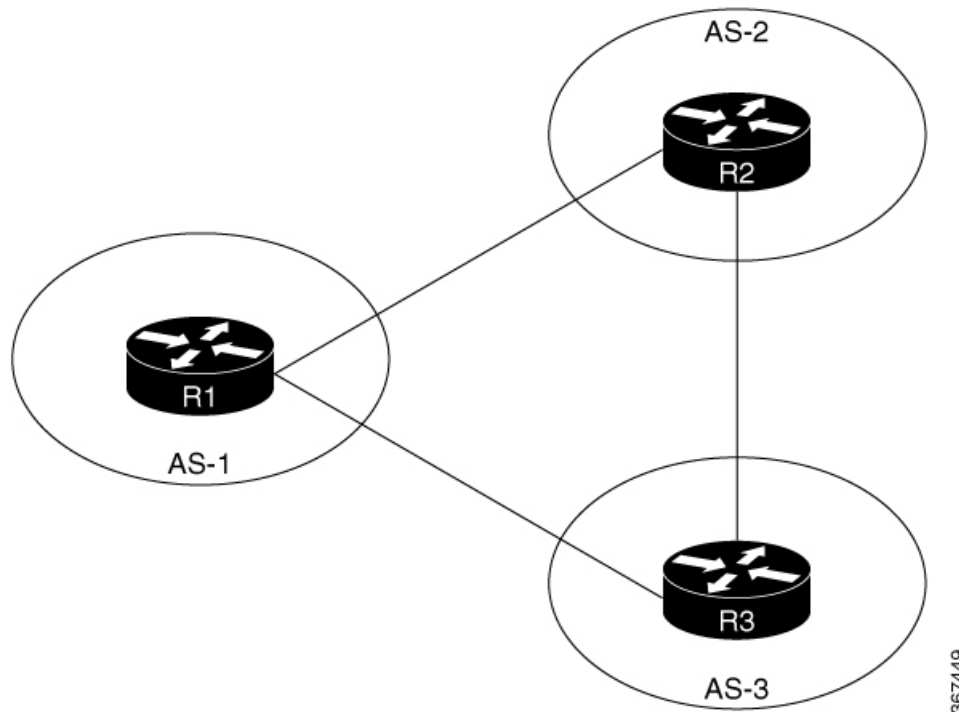

Consider three routers R1, R2 and R3 in different autonomous systems (AS-1, AS-2, and AS-3). The routers are connected with each other. R1 announces a prefix to R2 and R3. Both R2 and R3 are configured with multipath and also with **bgp multipath as-path ignore onwards** command. Since R3 is configured as multipath, R2 will send part of its traffic to R3. Similarly, R3 will send part of its traffic to R2. This creates a forwarding loop between R3 and R2. Therefore, to avoid such forwarding loops you should not configure the **bgp multipath as-path ignore onwards** command on connected routers.

## Overview of BGP Monitoring Protocol

The BGP Monitoring Protocol (BMP) feature enables monitoring of BGP speakers (called BMP clients). You can configure a device to function as a BMP server, which monitors either one or several BMP clients, which in turn, has several active peer sessions configured. You can also configure a BMP client to connect to one or more BMP servers. The BMP feature enables configuration of multiple BMP servers (configured as primary servers) to function actively and independent of each other, simultaneously to monitor BMP clients.

The BMP Protocol provides access to the Adjacent Routing Information Base, Incoming (Adj-RIB-In) table of a peer on an ongoing basis and a periodic dump of certain statistics that the monitoring station can use for further analysis. The BMP provides pre-policy view of the Adj-RIB-In table of a peer.

There can be several BMP servers configured globally across all the BGP instances. The BMP servers configured are common across multiple speaker instances and each BGP peer in an instance can be configured for

monitoring by all or a subset of the BMP servers, giving a 'any-to-any' map between BGP peers and BMP servers from the point of view of a BGP speaker. If a BMP server is configured before any of the BGP peers come up, then the monitoring will start as soon as the BGP peers come up. A BMP server configuration can be removed only when there are no BGP peers configured to be monitored by that particular BMP server.

Sessions between BMP clients and BMP servers operate over plain TCP (no encryption/encapsulation). If a TCP session with the BMP server is not established, the client retries to connect every 7 seconds.

The BMP server does not send any messages to its clients (BGP speakers). The message flow is in one direction only—from BGP speakers to the BMP servers

A maximum of eight BMP servers can be configured on the router. Each BMP server is specified by a server ID and certain parameters such as IP address, port number, etc are configurable. Upon successful configuration of a BMP server with host and port details, the BGP speaker attempts to connect to BMP Server. Once the TCP connection is setup, an Initiation message is sent as first message.

The **bmp server** command enables the user to configure multiple—independent and asynchronous—BMP server connections.

All neighbors for a BGP speaker need not necessarily be BMP clients. BMP clients are the ones that have direct TCP connection with a BMP server. Each of these BGP speakers can have many BGP neighbors or peers. Under a BGP speaker, if any of its neighbors are configured for BMP monitoring, only that particular peer router's messages are sent to BMP servers.

The session connection to BMP server is attempted after an initial-delay at the BMP client. This initial-delay can be configured. If the initial-delay is not configured, then the default connection delay of 7 seconds is used. Configuring the initial delay becomes significant under certain circumstances where, if multiple BMP servers' states toggle closely and refresh delay is so small, then this might result in redundant route-refreshes being generated. This causes considerable network traffic and load on the device. Having different initial delays can reduce the load spike on the network and router.

After the initial delay, TCP connection to BMP servers are attempted. Once the server connections are up, it is checked if there are any peers enabled for monitoring. Once a BGP peer that is already being monitored is in the “ESTAB” state, speaker sends a “peer-up” message for that peer to the BMP server. After the BGP peer receives a route-refresh request, neighbor sends the updates. This route refresh is initiated based on a delay configured for each BMP server. This is called route refresh delay. When there are multiple neighbors to be monitored, each neighbor is set a refresh delay based upon the BMP server they are enabled for. Once all the BGP neighbors have sent the updates in response to the refresh requests, the tables will be up to date in the BMP Server. If a neighbor establishes connection after BMP monitoring has begun, it does not require a route-refresh request. All received routes from that neighbor is sent to BMP servers.



---

**Note** In the case of BMP Pre Inbound Policy Route monitoring, when a new BMP server comes up, route refresh requests are sent to the peer router by the BGP speaker. However, in the case of BMP Post Inbound Policy Route Monitoring route refresh request are not sent to the peer routers when the new BMP server comes up because the BMP table is used for update generation.

---

It is advantageous to batch up refresh requests to BGP peers, if several BMP servers are activated in quick succession. Use the **bmp server initial-refresh-delay** command to configure a delay in triggering the refresh mechanism when the first BMP server comes up. If other BMP servers come online within this time-frame, only one set of refresh requests is sent to the BGP peers. You can also configure the **bmp server initial-refresh-delay skip** command to skip all refresh requests from BGP speakers and just monitor all incoming messages from the peers.

In a client-server configuration, it is recommended that the resource load of the devices be kept minimal and adding excessive network traffic must be avoided. In the BMP configuration, you can configure various delay timers on the BMP server to avoid flapping during connection between the server and client.

## BGP—Multiple Cluster IDs

The BGP—Multiple Cluster IDs feature allows an iBGP neighbor (usually a route reflector) to have multiple cluster IDs: a global cluster ID and additional cluster IDs that are assigned to clients (neighbors). Prior to the introduction of this feature, a device could have a single, global cluster ID.

When a network administrator configures per-neighbor cluster IDs:

- The loop prevention mechanism based on a CLUSTER\_LIST is automatically modified to take into account multiple cluster IDs.
- A network administrator can disable client-to-client route reflection based on cluster ID.

### Restriction

The BGP Multiple Cluster-IDs feature only works in default VRF.

## BGP Flowspec Overview

The BGP flow specification (flowspec) feature allows you to rapidly deploy and propagate filtering and policing functionality among many BGP peer routers to mitigate the effects of a distributed denial-of-service (DDoS) attack over your network.

BGP Flowspec feature allows you to construct instructions to match a particular flow with IPv4 and IPv6 source, IPv4 and IPv6 destination, L4 parameters and packet specifics such as length, fragment, destination port and source port, actions that must be taken, such as dropping the traffic, or policing it at a definite rate, or redirect the traffic, through a BGP update. In the BGP update, the flowspec matching criteria is represented by Network Layer Reachability Information (BGP NLRI) and the actions are represented by BGP extended communities.

You can use the BGP Flowspec feature for mitigation of DDoS attack. When a DDoS attack occurs on a particular host inside a network, you can send a flowspec update to the border routers so that the attack traffic can be policed or dropped, or even redirected elsewhere. For example, to an appliance that cleans the traffic by filtering out the bad traffic and forward only the good traffic toward the affected host.

Once flowspecs have been received by a router and programmed in applicable line cards, any active L3 ports on those line cards start processing ingress traffic according to flowspec rules.

The BGP Flowspec feature cannot coexist with MAP-E and PBR on a given interface. If you configure BGP Flowspec with PBR, the router does not display any error or system message. The router ignores the BGP Flowspec configuration and the feature will not function.

## Flow Specifications

A flow specification is an n-tuple consisting of several matching criteria that can be applied to IP traffic. A given IP packet matches the defined flow if it matches all the specified criteria.

Every flow-spec route is effectively a rule, consisting of a matching part (encoded in the NLRI field) and an action part (encoded as a BGP extended community). The BGP flowspec rules are converted internally to equivalent C3PL policy representing match and action parameters. The match and action support can vary

based on underlying platform hardware capabilities. Sections *Supported Matching Criteria and Actions* and *Traffic Filtering Actions* provide information on the supported match (tuple definitions) and action parameters.



**Note** Up to 2,000 flowspec rules are supported in Cisco 8000.

## Supported Matching Criteria and Actions

*Table 7: Feature History Table*

Feature Name	Release Name	Description
Additional BGP FlowSpec Actions for Enhanced Security	Release 7.3.3	<p>This release introduces additional BGP FlowSpec actions for enhanced security against distributed denial-of-service (DDoS) attacks.</p> <ul style="list-style-type: none"> <li>• <b>Redirect Nexthop VRF only:</b> Redirects the traffic to a different Autonomous System Number (ASN).</li> <li>• <b>Rate Limit and Redirect IPv4 or IPv6 Nexthop:</b> Redirects the traffic to the indicated nexthop IPv4 or IPv6 address. Policer rate regulates the traffic.</li> <li>• <b>Rate Limit and Redirect Nexthop VRF:</b> Redirects the traffic to the next hop IPv4 address through a VRF. Policer rate regulates the traffic. This action is supported only on Q200 Silicon One ASIC.</li> </ul>

Table 8: Feature History Table

Feature Name	Release Name	Description
BGP FlowSpec NLRI types	Release 7.3.15	<p>A BGP flow specification consists of several matching criteria encoded in the NLRI that is applied to IP traffic. A given IP packet must match all the specified criteria. Network layer reachability information (NLRI) exchanges routing information and matching criteria between BGP peers, indicating how to reach the destination.</p> <p>The following NLRI types are supported:</p> <ul style="list-style-type: none"> <li>• Type 7: IPv4 or IPv6 ICMP type</li> <li>• Type 8: IPv4 or IPv6 ICMP code</li> <li>• Type 9: IPv4 TCP flags (2 bytes include reserved bits)</li> <li>• Type 10: IPv4 Packet length</li> <li>• Type 11: IPv4 or IPv6 DSCP</li> <li>• Type 12: IPv4 fragmentation bits</li> </ul>
BGP FlowSpec Actions	Release 7.3.15	<p>This feature provides information on the actions that can be associated with a BGP flow. The traffic filtering flow specification is applied based on the specified rule. The following extended community values that can be used to specify particular action:</p> <ul style="list-style-type: none"> <li>• Set DSCP</li> <li>• Redirect IPv4 or IPv6 next hop</li> </ul>

### Overview

A flow specification NLRI type may include several components such as destination prefix, source prefix, protocol, ports, and so on. This NLRI is treated as an opaque bit string prefix by BGP. Each bit string identifies a key to a database entry with which a set of attributes can be associated. This NLRI information is encoded using MP\_REACH\_NLRI and MP\_UNREACH\_NLRI attributes. Whenever the corresponding application



does not require Next-Hop information, this is encoded as a 0-octet length Next Hop in the MP\_REACH\_NLRI attribute, and ignored. The NLRI field of the MP\_REACH\_NLRI and MP\_UNREACH\_NLRI is encoded as a 1- or 2-octet NLRI length field followed by a variable-length NLRI value. The NLRI length is expressed in octets.

The flow specification NLRI type consists of several optional sub-components. A specific packet is considered to match the flow specification when it matches the intersection and of all the components present in the specification. The following are the supported component types or tuples that you can define:

BGP Flowspec NLRI type	QoS Match Fields	Description and Syntax Construction	Value Input Method
Type 1	IPv4 or IPv6 destination address	<p>Defines the destination prefix to match. Prefixes are encoded in the BGP UPDATE messages as a length in bits followed by enough octets to contain the prefix information.</p> <p>Encoding: &lt;type (1 octet), prefix length (1 octet), prefix&gt;</p> <p><b>Syntax:</b></p> <p><b>match destination-address {ipv4   ipv6} address/mask length</b></p>	Prefix length
Type 2	IPv4 or IPv6 source address	<p>Defines the source prefix to match.</p> <p>Encoding: &lt;type (1 octet), prefix-length (1 octet), prefix&gt;</p> <p><b>Syntax:</b></p> <p><b>match source-address {ipv4   ipv6} address/mask length</b></p>	Prefix length
Type 3	IPv4 or IPv6 protocol	<p>Contains a set of {operator, value} pairs that are used to match the IP protocol value byte in IP packets.</p> <p>Encoding: &lt;type (1 octet), [op, value]+&gt;</p> <p><b>Syntax:</b></p> <p><b>match protocol {protocol-value   [min-value - max-value]}</b></p>	<p>Single value</p> <p><b>Note</b> Multi-value range is not supported</p>

Type 4	IPv4 or IPv6 source or destination port	<p>Defines a list of {operation, value} pairs that matches source or destination TCP or UDP ports. Values are encoded as 1- or 2-byte quantities. Port, source port, and destination port components evaluate to FALSE if the IP protocol field of the packet has a value other than TCP or UDP. If the packet is fragmented and this is not the first fragment, or if the system is unable to locate the transport header.</p> <p>Encoding: &lt;type (1 octet), [op, value]+&gt;</p> <p><b>Syntax:</b></p> <p><b>match source-port</b> { <i>source-port-value</i>   <i>min-value</i> - <i>max-value</i> }</p> <p><b>match destination-port</b> { <i>destination-port-value</i>   <i>min-value</i> - <i>max-value</i> }</p>	Multi-value range
Type 5	IPv4 or IPv6 destination port	<p>Defines a list of {operation, value} pairs used to match the destination port of a TCP or UDP packet. Values are encoded as 1- or 2-byte quantities.</p> <p>Encoding: &lt;type (1 octet), [op, value]+&gt;</p> <p><b>Syntax:</b></p> <p><b>match destination-port</b> { <i>destination-port-value</i>   [<i>min-value</i> - <i>max-value</i>] }</p>	Multi-value range
Type 6	IPv4 or IPv6 Source port	<p>Defines a list of {operation, value} pairs used to match the source port of a TCP or UDP packet. Values are encoded as 1- or 2-byte quantities.</p> <p>Encoding: &lt;type (1 octet), [op, value]+&gt;</p> <p><b>Syntax:</b></p> <p><b>match source-port</b> { <i>source-port-value</i>   [<i>min-value</i> - <i>max-value</i>] }</p>	Multi-value range

Type 7	IPv4 or IPv6 ICMP type	<p>Defines a list of {operation, value} pairs used to match the type field of an ICMP packet. Values are encoded using a single byte. The ICMP type and code specifiers evaluate to FALSE whenever the protocol value is not ICMP.</p> <p>Encoding: &lt;type (1 octet), [op, value]+&gt;</p> <p><b>Syntax:</b></p> <p><b>match {ipv4   ipv6} icmp-type {value   min-value -max-value}</b></p>	<p>Single value</p> <p><b>Note</b> Multi-value range is not supported</p>
Type 8	IPv4 or IPv6 ICMP code	<p>Defines a list of {operation, value} pairs used to match the code field of an ICMP packet. Values are encoded using a single byte.</p> <p><b>Syntax:</b></p> <p>Encoding: &lt;type (1 octet), [op, value]+&gt;</p> <p><b>match {ipv4   ipv6} icmp-type {value   min-value -max-value}</b></p>	<p>Single value</p> <p><b>Note</b> Multi-value range is not supported</p>
Type 9	<p>IPv4 or IPv6 TCP flags (2 bytes include reserved bits)</p> <p><b>Note</b> Reserved and NS bit not supported</p>	<p>Bitmask values can be encoded as a 1- or 2-byte bitmask. When a single byte is specified, it matches byte 13 of the TCP header, which contains bits 8 through 15 of the 4th 32-bit word. When a 2-byte encoding is used, it matches bytes 12 and 13 of the TCP header with the data offset field having a "don't care" value. As with port specifier, this component evaluates to FALSE for packets that are not TCP packets. This type uses the bitmask operand format, which differs from the numeric operator format in the lower nibble.</p> <p>Encoding: &lt;type (1 octet), [op, bitmask]+&gt;</p> <p><b>Syntax:</b></p> <p><b>match tcp-flag value bit-mask mask_value</b></p>	<p>Bit mask</p>

Type 10	<p>IPv4 Packet length</p> <p><b>Note</b></p> <ul style="list-style-type: none"> <li>• Reserved and NS bit not supported</li> <li>• IPv4 or IPv6 support is available for the packets that are not the first fragment packets.</li> </ul>	<p>Match on the total IP packet length (excluding Layer 2, but including IP header). Values are encoded using 1- or 2-byte quantities.</p> <p>Encoding: &lt;type (1 octet), [op, value]+&gt;</p> <p><b>Syntax:</b></p> <p><b>matchpacket length</b> {packet-length-value  min-value -max-value}</p>	Multi-value range
Type 11	IPv4 or IPv6 DSCP	<p>Defines a list of (operation, value) pairs used to match the 6-bit DSCP field. Values are encoded using a single byte, whereas the two most significant bits are zero and the six least significant bits contain the DSCP value.</p> <p><b>Note</b> The DSCP does not contain Flowspec statistics.</p> <p>Encoding: &lt;type (1 octet), [op, value]+&gt;</p> <p><b>Syntax:</b></p> <p><b>match dscp</b> {dscp-value  min-value -max-value}</p>	Multi-value range
Type 12	<p>IPv4 Fragmentation bits</p> <p><b>Note</b> IPv4 support is available for the packets that are not the first fragment packets.</p> <p>IPv6 BGP flowspec does not support Type 12 NRLI.</p>	<p>Identifies a fragment-type as the match criterion for a class map.</p> <p>Encoding: &lt;type (1 octet), [op, bitmask]+&gt;</p> <p><b>Syntax:</b></p> <p><b>match fragment type [is-fragment]</b></p>	Bit mask

In a given flowspec rule, 2-tuple action combinations can be specified without restrictions. However, mixing address family between matching criterion and actions are not allowed. For example, IPv4 matches cannot be combined with IPv6 actions and vice versa.

## Limitations for BGP FlowSpec

These limitations apply to the BGP FlowSpec feature.

- BGP Flowspec statistics are not supported when there is Redirect Nexthop VRF.
- BGP Flowspec statistics are supported when there is a policer rate limit.

The policer action scale is limited to a maximum of 128 per slice.

- BGP Flowspec statistics are supported in Redirect action only when a policer is attached. BGP Flowspec statistics is not supported for Redirect action alone.
- VRF to default VRF redirect is not supported.

## Traffic Filtering Actions

The default action for a traffic filtering flow specification is to accept IP traffic that matches that particular rule. The following extended community values can be used to specify particular actions:



**Note** The BGP flowspec actions *rate limit* and *redirect* are not supported together.

The BGP flowspec action *redirect* is supported only for nexthop IPv4 and IPv6 not with nexthop VRF IPv4 and IPv6.

Type	Extended Community	PBR Action	Description
0x8006	traffic-rate 0 traffic-rate <rate>	Drop Police	<p>The traffic-rate extended community is a non-transitive extended community across the autonomous-system boundary and uses following extended community encoding:</p> <p>The first two octets carry the 2-octet id, which can be assigned from a 2-byte AS number. When a 4-byte AS number is locally present, the 2 least significant bytes of such an AS number can be used. This value is informational. The remaining 4 octets carry the rate information in IEEE floating point [IEEE.754.1985] format, bytes per second. A traffic-rate of 0 should result on all traffic for the particular flow to be discarded.</p> <p><b>Command syntax</b> police rate &lt;&gt;   drop</p>

0x8009	traffic-marking	Set DSCP	<p>The traffic marking extended community instructs a system to modify the differentiated service code point (DSCP) bits of a transiting IP packet to the corresponding value. This extended community is encoded as a sequence of 5 zero bytes followed by the DSCP value encoded in the 6 least significant bits of 6th byte.</p> <p><b>Command syntax</b></p> <pre>set dscp &lt;6 bit value&gt;</pre>
0x0800	Redirect IP NH	Redirect IPv4 or IPv6 Nexthop	<p>Announces the reachability of one or more flowspec NLRI. When a BGP speaker receives an UPDATE message with the redirect-to- IP extended community it is expected to create a traffic filtering rule for every flow-spec NLRI in the message that has this path as its best path. The filter entry matches the IP packets described in the NLRI field and redirects them or copies them towards the IPv4 or IPv6 address specified in the Network Address of Next-Hop field of the associated MP_REACH_NLRI.</p> <p><b>Note</b> The redirect-to-IP extended community is valid with any other set of flow-spec extended communities except if that set includes a redirect-to-VRF extended community (type 0x8008) and in that case the redirect-to-IP extended community should be ignored.</p> <p><b>Note</b> Redirect IP NH is supported only in default VRF.</p> <p><b>Command syntax</b></p> <pre>redirect {ipv4   ipv6} next-hop {ipv4-address   ipv6-address}</pre>

## BGP Flowspec Client-Server Controller Model

The BGP Flowspec model comprises of a client and a server Controller. The Controller is responsible for sending or injecting the flowspec NRLI entry. The client (acting as a BGP speaker) receives that NRLI and programs the hardware forwarding to act on the instruction from the Controller. An illustration of this model is provided below.

### BGP Flowspec Client

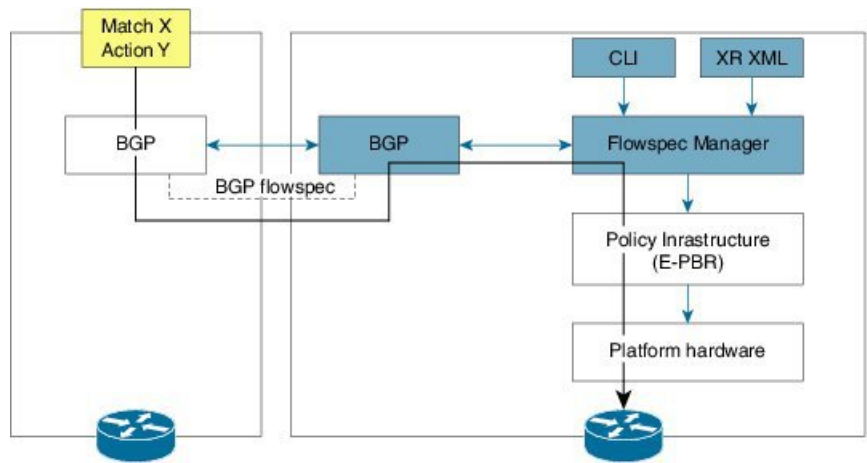

Here, the Controller on the left-hand side injects the flowspec NRLI, and the client on the right-hand side receives the information, sends it to the flowspec manager, configures the ePBR (Enhanced Policy-based Routing) infrastructure, which in turn programs the hardware from the underlying platform in use.

**BGP Flowspec Controller**

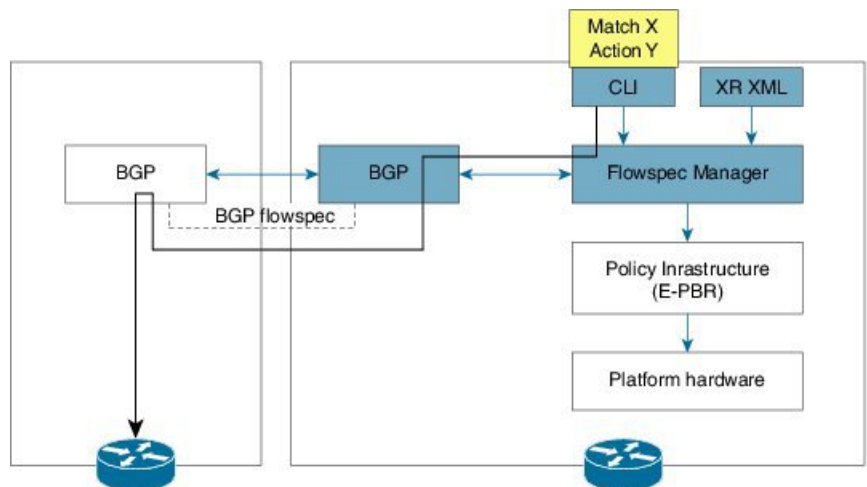

The Controller is configured using CLI to provide an entry for NRLI injection.

**Configure BGP Flowspec**

The following sections show how to configure BGP Flowspec feature.

Figure 12: BGP Flowspec

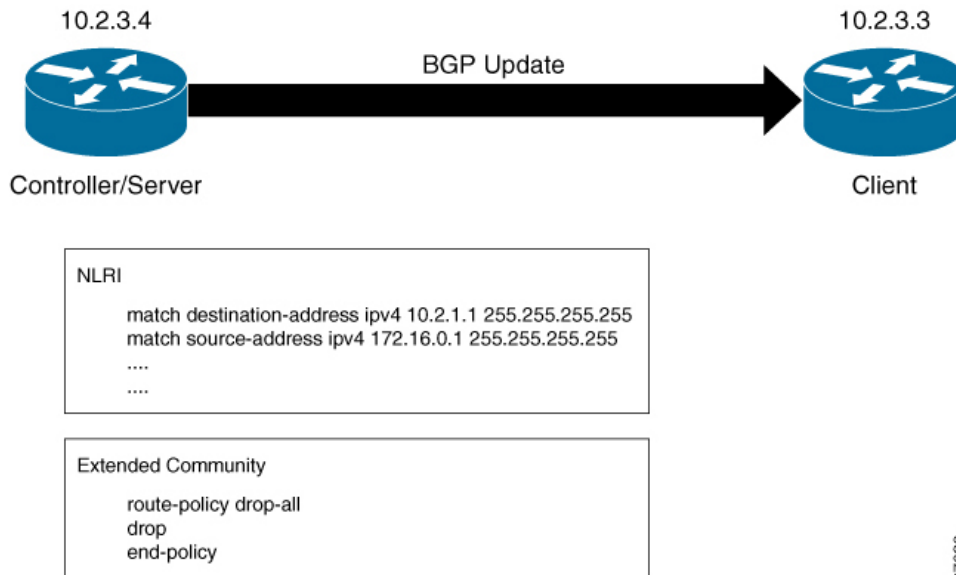

367630

The controller or the server with IP address 10.2.3.4 sends the Flowspec NLRI to the client with IP address 10.2.3.3. The NLRI consists of matching criteria, the client processes based on this criteria. Traffic is dropped or accepted based on the configured criteria.

The following section describes how you can configure BGP Flowspec on the client:

```

/*Configure BGP Flowspec */
Router(config)# flowspec
Router(config-flowspec)# address-family ipv4
Router(config-flowspec-af)# local-install interface-all
Router(config-flowspec-af)# exit
Router(config-flowspec)# address-family ipv6
Router(config-flowspec-af)# local-install interface-all
Router(config-flowspec-af)# exit

/* Configure the policy to accept all presented routes without modifying the routes */
Router(config)# route-policy pass-all
Router(config)# pass
Router(config)# end-policy

/* Configure the policy to reject all presented routes without modifying the routes */
Router(config)# route-policy drop-all
Router(config)# drop
Router(config)# end-policy

/* Configure BGP towards flowspec server */
Router(config)# router bgp 1
Router(config-bgp)# nsr
Router(config-bgp)# bgp router-id 10.2.3.3
Router(config-bgp)# address-family ipv4 flowspec
Router(config-bgp-af)# exit
Router(config-bgp)# address-family ipv6 flowspec
Router(config-bgp-af)# exit
Router(config-bgp)# neighbor 10.2.3.4
Router(config-bgp-nbr)# remote-as 1
  
```



```

Router(config-bgp-nbr)# address-family ipv4 flowspec
Router(config-bgp-nbr-af)# route-policy pass-all in
Router(config-bgp-nbr-af)# route-policy drop-all out
Router(config-bgp-af)# exit
Router(config-bgp-nbr)# address-family ipv6 flowspec
Router(config-bgp-nbr-af)# route-policy pass-all in
Router(config-bgp-nbr-af)# route-policy drop-all out
Router(config-bgp-nbr-af)# exit
Router(config-bgp-nbr)# update-source Loopback0

/* Disable BGP Flowspec */
Router(config)# interface bundle-ether 3.1
Router(config-subif)# ipv4 flowspec disable
Router(config-subif)# ipv6 flowspec disable

The following section describes how you can configure BGP Flowspec on the server:
/* Configure the policy to accept all presented routes without modifying the routes */
Router(config)# route-policy pass-all
Router(config)# pass
Router(config)# end-policy

/* Configure the policy to reject all presented routes without modifying the routes */
Router(config)# route-policy drop-all
Router(config)# drop
Router(config)# end-policy

/* Configure BGP towards flowspec client */
Router(config)# router bgp 1
Router(config-bgp)# nsr
Router(config-bgp)# bgp router-id 10.2.3.4
Router(config-bgp)# address-family ipv4 flowspec
Router(config-bgp-af)# exit
Router(config-bgp)# address-family ipv6 flowspec
Router(config-bgp-af)# exit
Router(config-bgp)# neighbor 10.2.3.3
Router(config-bgp-nbr)# remote-as 1
Router(config-bgp-nbr)# address-family ipv4 flowspec
Router(config-bgp-nbr-af)# route-policy pass-all in
Router(config-bgp-nbr-af)# route-policy pass-all out
Router(config-bgp-nbr-af)# exit
Router(config-bgp-nbr)# update-source Loopback0

/* Configure IPv4 flowspec to be advertised to client. Define traffic classes. */
Router(config)# class-map type traffic match-all ipv4_fragment
Router(config-cmap)# match destination-address ipv4 10.2.1.1 255.255.255.255
Router(config-cmap)# match source-address ipv4 172.16.0.1 255.255.255.255

Router(config-cmap)# end-class-map
Router(config)# class-map type traffic match-all ipv4_icmp
Router(config-cmap)# match destination-address ipv4 10.2.1.1 255.255.255.255
Router(config-cmap)# match source-address ipv4 172.16.0.1 255.255.255.255
Router(config-cmap)# end-class-map

/* Define a policy map and associate it with traffic classes.
Router(config)# policy-map type pbr scale_ipv4
Router(config-pmap)# class type traffic ipv4_fragment
Router(config-pmap-c)# drop
Router(config-pmap-c)# exit
Router(config-pmap)# class type traffic ipv4_icmp
Router(config-pmap-c)# exit
Router(config-pmap)# class type traffic class-default
Router(config-pmap-c)# end-policy-map
Router(config)# flowspec

```

```

Router(config)# address-family ipv4
Router(config-af)# service-policy type pbr scale_ipv4

/* Configure IPv6 flowspec to be advertised to client. Define traffic classes. */
Router(config)# class-map type traffic match-all ipv6_tcp
Router(config-cmap)# match destination-address ipv6 70:1:1::5a/128
Router(config-cmap)# match source-address ipv4 ipv6 80:1:1::5a/128
Router(config-cmap)# match destination-port 22
Router(config-cmap)# match source-port 4000
Router(config-cmap)# end-class-map
Router(config)# class-map type traffic match-all ipv6_icmp
Router(config-cmap)# match destination-address ipv6 70:2:1::1/128
Router(config-cmap)# match source-address ipv4 ipv6 80:2:1::1/128
Router(config-cmap)# end-class-map

/* Define a policy map and associate it with traffic classes.
Router(config)# policy-map type pbr scale_ipv6
Router(config-pmap)# class type traffic ipv6_tcp
Router(config-pmap-c)# exit
Router(config-pmap)# class type traffic ipv6_icmp
Router(config-pmap-c)# exit
Router(config-pmap)# class type traffic class-default
Router(config-pmap-c)# end-policy-map
Router(config)# flowspec
Router(config)# address-family ipv6
Router(config-af)# service-policy type pbr scale_ipv6

/* Class map configuration with DSCP */
Router(config-map)# class-map type traffic match-all class_dscp_5
Router(config-cmap)# match destination-address ipv4 192.0.2.254 255.255.255.0
Router(config-cmap)# match dscp 10-12

/* Policy map configuration with IPv4 Redirect and Rate Limiter */
Router(config-pmap)#class type traffic class_dscp_5
Router(config-pmap-c)#redirect ipv4 nexthop 10.26.245.2
Router(config-pmap-c)#police rate 5 mbps
Router(config-pmap-c)# root

```

## Running Configuration

```

/* Client-side configuration */

flowspec
address-family ipv4
local-install interface-all
!
address-family ipv6
local-install interface-all
!
!
route-policy pass-all
pass
end-policy
!
route-policy drop-all
drop
end-policy
!
router bgp 1
nsr
bgp router-id 10.2.3.3
address-family ipv4 flowspec
!

```

```
address-family ipv6 flowspec
!
neighbor 10.2.3.4
remote-as 1
address-family ipv4 flowspec
route-policy pass-all in
route-policy drop-all out
!
address-family ipv6 flowspec
route-policy pass-all in
route-policy drop-all out
!
update-source Loopback0
!
!
vrf vrfl
address-family ipv4 unicast
import route-target
4787:13
!
export route-target
4787:13
!
!
address-family ipv6 unicast
import route-target
4787:13
!
export route-target
4787:13
!
!
!
router static
vrf vrfl
address-family ipv4 unicast
10.0.0.0/8 200.255.55.2
!
!
!
/* Disable the flowspec. This is optional configuration */
interface Bundle-Ether3.1
ipv4 flowspec disable
ipv6 flowspec disable
!
/* Server-side Configuration */
route-policy pass-all
pass
end-policy
!
route-policy drop-all
drop
end-policy
!
router bgp 1
nsr
bgp router-id 10.2.3.4
address-family ipv4 flowspec
!
address-family ipv6 flowspec
!
neighbor 10.2.3.3
remote-as 1
address-family ipv4 flowspec
```

```

route-policy drop-all in
route-policy pass-all out
exit
update-source Loopback0
!
!
class-map type traffic match-all ipv4_fragment
match destination-address ipv4 10.2.1.1 255.255.255.255
end-class-map
!
class-map type traffic match-all ipv4_icmp
match destination-address ipv4 10.2.1.1 255.255.255.255
match source-address ipv4 172.16.0.1 255.255.255.255
end-class-map
!
policy-map type pbr scale_ipv4
class type traffic ipv4_fragment
drop
!
class type traffic ipv4_icmp
!
!
class type traffic class-default
!
end-policy-map
!
flowspec
address-family ipv4
service-policy type pbr scale_ipv4
!
!
class-map type traffic match-all ipv6_tcp
match destination-address ipv6 70:1:1::5a/128
match source-address ipv6 80:1:1::5a/128
match protocol tcp
match destination-port 22
match source-port 4000
end-class-map
!
class-map type traffic match-all ipv6_icmp
match destination-address ipv6 70:2:1::1/128
match source-address ipv6 80:2:1::1/128
end-class-map
!
policy-map type pbr scale_ipv6
class type traffic ipv6_tcp
!
!
class type traffic ipv6_icmp
!
!
class type traffic class-default
!
!
flowspec
address-family ipv6
service-policy type pbr scale_ipv6
!
!

```

### Verification

The following show output displays the status of the flowspec from the client side.

```

Router# show bgp ipv4 flowspec
GP router identifier 202.158.0.1, local AS number 4787
BGP generic scan interval 60 secs
Non-stop routing is enabled
BGP table state: Active
Table ID: 0x0 RD version: 7506
BGP main routing table version 7506
BGP NSR Initial initsync version 130 (Reached)
BGP NSR/ISSU Sync-Group versions 7506/0
BGP scan interval 60 secs
Status codes: s suppressed, d damped, h history, * valid, > best
i - internal, r RIB-failure, S stale, N Nexthop-discard
Origin codes: i - IGP, e - EGP, ? - incomplete
Network Next Hop Metric LocPrf Weight Path
*>iDest:10.1.1.1/32,Proto:=6,DPort:=80,SPort:=3000,Length:=200,DSCP:=10/176
0.0.0.0 10 0 ?
*>iDest:10.1.1.2/32,Proto:=6,DPort:=80,SPort:=3000,Length:=200,DSCP:=10/176
0.0.0.0 10 0 ?
*>iDest:10.1.1.3/32,Proto:=6,DPort:=80,SPort:=3000,Length:=200,DSCP:=10/176
0.0.0.0 10 0 ?
*>iDest:10.1.1.4/32,Proto:=6,DPort:=80,SPort:=3000,Length:=200,DSCP:=10/176
0.0.0.0 10 0 ?
*>iDest:10.1.1.5/32,Proto:=6,DPort:=80,SPort:=3000,Length:=200,DSCP:=10/176
0.0.0.0 10 0 ?

Router# show bgp ipv6 flowspec

BGP router identifier 202.158.0.1, local AS number 4787
BGP generic scan interval 60 secs
Non-stop routing is enabled
BGP table state: Active
Table ID: 0x0 RD version: 1503
BGP main routing table version 1504
BGP NSR Initial initsync version 2 (Reached)
BGP NSR/ISSU Sync-Group versions 1504/0
BGP scan interval 60 secs
Status codes: s suppressed, d damped, h history, * valid, > best
i - internal, r RIB-failure, S stale, N Nexthop-discard
Origin codes: i - IGP, e - EGP, ? - incomplete
Network Next Hop Metric LocPrf Weight Path
*>iDest:70:1:1::1/0-128,Source:80:1:1::1/0-128,NH:=6,DPort:=22,SPort:=4000,TCPFlags:=0x10,Length:=300,DSCP:=12/464
202:158:2::1 100 0 i
*>iDest:70:1:1::2/0-128,Source:80:1:1::2/0-128,NH:=6,DPort:=22,SPort:=4000,TCPFlags:=0x10,Length:=300,DSCP:=12/464
202:158:2::1 100 0 i
*>iDest:70:1:1::3/0-128,Source:80:1:1::3/0-128,NH:=6,DPort:=22,SPort:=4000,TCPFlags:=0x10,Length:=300,DSCP:=12/464
202:158:2::1 100 0 i
*>iDest:70:1:1::4/0-128,Source:80:1:1::4/0-128,NH:=6,DPort:=22,SPort:=4000,TCPFlags:=0x10,Length:=300,DSCP:=12/464
202:158:2::1 100 0 i
*>iDest:70:1:1::5/0-128,Source:80:1:1::5/0-128,NH:=6,DPort:=22,SPort:=4000,TCPFlags:=0x10,Length:=300,DSCP:=12/464
202:158:2::1 100 0 i

Router# show bgp vpnv4 flowspec
BGP router identifier 202.158.0.1, local AS number 4787
BGP generic scan interval 60 secs
Non-stop routing is enabled
BGP table state: Active
Table ID: 0x0 RD version: 0
BGP main routing table version 5
BGP NSR Initial initsync version 3 (Reached)
BGP NSR/ISSU Sync-Group versions 5/0
BGP scan interval 60 secs
Status codes: s suppressed, d damped, h history, * valid, > best
i - internal, r RIB-failure, S stale, N Nexthop-discard
Origin codes: i - IGP, e - EGP, ? - incomplete

```

```

Network Next Hop Metric LocPrf Weight Path
Route Distinguisher: 202.158.0.1:0 (default for vrf customer_1)
*>iDest:202.158.3.2/32,Source:202.158.1.2/32/96
0.0.0.0 100 0 i
Route Distinguisher: 202.158.0.2:1
*>iDest:202.158.3.2/32,Source:202.158.1.2/32/96
0.0.0.0 100 0 i
Processed 2 prefixes, 2 paths

Router# show bgp vpnv6 flowspec
BGP router identifier 202.158.0.1, local AS number 4787
BGP generic scan interval 60 secs
Non-stop routing is enabled
BGP table state: Active
Table ID: 0x0 RD version: 0
BGP main routing table version 5
BGP NSR Initial initsync version 4 (Reached)
BGP NSR/ISSU Sync-Group versions 5/0
BGP scan interval 60 secs
Status codes: s suppressed, d damped, h history, * valid, > best
i - internal, r RIB-failure, S stale, N NextHop-discard
Origin codes: i - IGP, e - EGP, ? - incomplete
Network Next Hop Metric LocPrf Weight Path
Route Distinguisher: 202.158.0.1:0 (default for vrf customer_1)
*>iDest:200:158:3::2/0-128,Source:200:158:1::2/0-128,NH:=6,DPort:=22,SPort:=4000,Length:=300,DSCP:=12/440
0.0.0.0 100 0 i
Route Distinguisher: 202.158.0.2:1
*>iDest:200:158:3::2/0-128,Source:200:158:1::2/0-128,NH:=6,DPort:=22,SPort:=4000,Length:=300,DSCP:=12/440
0.0.0.0 100 0 i
Processed 2 prefixes, 2 paths

Router# show bgp ipv6 flowspec summary
BGP router identifier 202.158.0.1, local AS number 4787
BGP generic scan interval 60 secs
Non-stop routing is enabled
BGP table state: Active
Table ID: 0x0 RD version: 1503
BGP main routing table version 1504
BGP NSR Initial initsync version 2 (Reached)
BGP NSR/ISSU Sync-Group versions 1504/0
BGP scan interval 60 secs
BGP is operating in STANDALONE mode.
Process RcvTblVer bRIB/RIB LabelVer ImportVer SendTblVer StandbyVer
Speaker 1504 1504 1504 1504 1504 1504
Neighbor Spk AS MsgRcvd MsgSent TblVer InQ OutQ Up/Down St/PfxRcd
200.255.1.5 0 4787 6957 2957 1504 0 0 04:48:02 0
200.255.1.6 0 50011 3015 3010 0 0 0 05:27:50 (NoNeg)
202.158.2.1 0 4787 1548 1648 1504 0 0 1d01h 750 <-- this
many flowspecs were received from server
202.158.3.1 0 4787 1683 1644 1504 0 0 1d01h 751
202.158.4.1 0 4787 1543 1649 1504 0 0 1d01h 0

Router# show bgp vpnv4 flowspec summary
BGP router identifier 202.158.0.1, local AS number 4787
BGP generic scan interval 60 secs
Non-stop routing is enabled
BGP table state: Active
Table ID: 0x0 RD version: 0
BGP main routing table version 5
BGP NSR Initial initsync version 3 (Reached)
BGP NSR/ISSU Sync-Group versions 5/0
BGP scan interval 60 secs
BGP is operating in STANDALONE mode.

```

```

Process RcvTblVer bRIB/RIB LabelVer ImportVer SendTblVer StandbyVer
Speaker 5 5 5 5 5
Neighbor Spk AS MsgRcvd MsgSent TblVer InQ OutQ Up/Down St/PfxRcd
202.158.2.1 0 4787 1549 1648 5 0 0 1d01h 1 <-- this
many flowspecs were received from server
202.158.3.1 0 4787 1684 1644 5 0 0 1d01h 0
202.158.4.1 0 4787 1543 1649 5 0 0 1d01h 0

```

```

Router# show bgp vpnv6 flowspec summary
BGP router identifier 202.158.0.1, local AS number 4787
BGP generic scan interval 60 secs
Non-stop routing is enabled
BGP table state: Active
Table ID: 0x0 RD version: 0
BGP main routing table version 5
BGP NSR Initial initsync version 4 (Reached)
BGP NSR/ISSU Sync-Group versions 5/0
BGP scan interval 60 secs
BGP is operating in STANDALONE mode.
Process RcvTblVer bRIB/RIB LabelVer ImportVer SendTblVer StandbyVer
Speaker 5 5 5 5 5
Neighbor Spk AS MsgRcvd MsgSent TblVer InQ OutQ Up/Down St/PfxRcd
202.158.2.1 0 4787 1549 1649 5 0 0 1d01h 1 <-- this
many flowspecs were received from server
202.158.3.1 0 4787 1684 1645 5 0 0 1d01h 0
202.158.4.1 0 4787 1543 1650 5 0 0 1d01h 0

```

```

Router# show flowspec ipv4 detail
AFI: IPv4
Flow :Dest:10.1.1.1/32,Proto:=6,DPort:=80,SPort:=3000,Length:=200,DSCP:=10
Actions :Traffic-rate: 0 bps (bgp.1)
Statistics (packets/bytes)
Matched : 18174999/3707699796
Transmitted : 0/0
Dropped : 18174999/3707699796

```

```

Router# show flowspec ipv6 detail
AFI: IPv6
Flow
:Dest:70:1::1/0-128,Source:80:1::1/0-128,NH:=6,DPort:=22,SPort:=4000,TCPFlags:=0x10,Length:=300,DSCP:=12
Actions :Traffic-rate: 1000000 bps DSCP: cs1 Nexthop: 202:158:2::1 (bgp.1)
Statistics (packets/bytes)
Matched : 64091597/19483845488
Transmitted : 33973978/10328089312
Dropped : 30117619/9155756176

```

```

Router# show flowspec vrf customer_1 ipv4 detail
VRF: customer_1 AFI: IPv4
Flow :Dest:202.158.3.2/32,Source:202.158.1.2/32
Actions :Traffic-rate: 250000000 bps DSCP: cs6 Redirect: VRF dirty_dancing
Route-target: ASN2-4787:666 (bgp.1)
Statistics (packets/bytes)
Matched : 37260786850/4098686553500
Transmitted : 21304093027/2343450232970
Dropped : 15956693823/1755236320530

```

```

Router# show flowspec vrf customer_1 ipv6 detail
VRF: customer_1 AFI: IPv6
Flow
:Dest:200:158:3::2/0-128,Source:200:158:1::2/0-128,NH:=6,DPort:=22,SPort:=4000,Length:=300,DSCP:=12
Actions :Traffic-rate: 250000000 bps DSCP: cs6 Redirect: VRF dirty_dancing
Route-target: ASN2-4787:666 (bgp.1)
Statistics (packets/bytes)
Matched : 16130480136/4903665961344

```





## BGP Extended Route Retention

Table 9: Feature History Table

Feature Name	Release Name	Description
BGP Extended Route Retention	Release 7.3.3	This feature allows you to maintain stale routing information from a failed BGP peer for longer periods of time than that is configured in the Graceful Restart attribute. However, this feature ensures that the BGP neighbor considers the stale routes as new routes.

When a BGP peer fails, the Extended Route Retention feature applies the route retention policy to the routes to modify the route attributes. This feature modifies the route attributes in addition to the modification that occur due to neighbor's inbound policy. This feature enables the use of route retention policy in place of LLGR, when the BGP hold timer expires or when the BGP session fails to reestablish as a receiving speaker within the configured graceful restart timer.

When you apply LLGR, you cannot remove the LLGR\_STALE community when the stale route is advertised, and the route will treat it as the least preferred. Also, stale routes may be advertised to those neighbors that would not have advertised the LLGR capability under the following conditions:

- The neighbors must be internal (IBGP or confederation) neighbors.
- The NO\_EXPORT community must be attached to the stale routes.
- The stale routes must have their LOCAL\_PREF community set to zero.

This feature provides you the flexibility to advertise stale routes to eBGP neighbors and enable you to specify local preference values for any stale route that is retained within the iBGP system.

### Restrictions

- The neighbor should be capable of graceful restart.
- When the BGP neighbor fails, the graceful restart functionality is applied till the graceful restart timer is valid.
- The Extended Route Retention feature starts, when the graceful restart timer expires,
- Soft-reconfiguration inbound configuration is a mandatory configuration. If required, configure the inbound policy.
- The Extended Route Retention feature starts only when BGP peer goes down, that is, on the expiry of the hold-down timer.
- For any other trigger, such as the expiry of a timer, the routes will not be indicated as stale and the routes is purged.
- The Extended Route Retention feature is applicable only to the following address-family modes:
  - IPv4 and IPv6 unicast address family mode

- IPv4 and IPv4 labelled unicast address family mode
- You cannot configure both LLGR and Extended Route Retention feature on the same neighbor.
- When you configure the Extended Route Retention feature, the capability attribute is not sent.

### Configuration Example

## How a CLUSTER\_LIST Attribute is Used

The CLUSTER\_LIST propagation rules differ among releases, depending on whether the device is running a Cisco software release generated before or after the BGP—Multiple Cluster IDs feature was implemented. The same is true for loop prevention based on the CLUSTER\_LIST.

The CLUSTER\_LIST behavior is described below. Classic refers to the behavior of software released before the multiple cluster IDs feature was implemented; MCID refers to the behavior of software released after the feature was implemented.

### CLUSTER\_LIST Propagation Rules

- Classic—Before reflecting a route, the RR appends the global cluster ID to the CLUSTER\_LIST. If the received route had no CLUSTER\_LIST attribute, the RR creates a new CLUSTER\_LIST attribute with that global cluster ID.
- MCID—Before reflecting a route, the RR appends the cluster ID of the neighbor the route was received from to the CLUSTER\_LIST. If the received route had no CLUSTER\_LIST attribute, the RR creates a new CLUSTER\_LIST attribute with that cluster ID. This behavior includes a neighbor that is not a client of the speaker. If the nonclient neighbor the route was received from does not have an associated cluster ID, the RR uses the global cluster ID.

### Loop Prevention Based on CLUSTER\_LIST

- Classic—When receiving a route, the RR discards the route if the RR's global cluster ID is contained in the CLUSTER\_LIST of the route.
- MCID—When receiving a route, the RR discards the route if the RR's global cluster ID or any of the cluster IDs assigned to any of the iBGP neighbors is contained in the CLUSTER\_LIST of the route.

## Configure a Cluster ID per Neighbor

Perform this task on an iBGP peer, usually a route reflector, to configure a cluster ID per neighbor. Configuring a cluster ID per neighbor causes the loop-prevention mechanism based on the CLUSTER\_LIST to be automatically modified to take into account multiple cluster IDs. Also, you gain the ability to disable client-to-client route reflection on the basis of cluster ID. The software tags the neighbor so that you can disable route reflection with the use of another command.



---

**Note** When you change a cluster ID for a neighbor, BGP automatically does an inbound soft refresh and an outbound soft refresh for all iBGP peers.

---

```
Router> enable
Router # configure terminal
```

```
Router(config)# router bgp 65000
Router(config-router)# neighbor 192.168.1.2
Router(config-router)# remote-as 65000
Router(config-router)# cluster-id 0.0.0.1
Router(config-router)# end
```

### Running Configuration

```
!
!
router bgp 65000
  neighbor 192.168.1.2
  remote-as 65000
  cluster-id 0.0.0.1
```

### Verification

The following example shows that if a cluster-id is configured on any level, either global or per-neighbour, it will be added to the active cluster IDs regardless of the neighbour state. BGP does not track the neighbour state for this feature.

```
Router# show bgp process detail

BGP Process Information:
BGP is operating in STANDALONE mode
Autonomous System number format: ASPLAIN
Autonomous System: 65000
Router ID: 10.10.1.92 (manually configured)
Default Cluster ID: 10.10.1.92
Active Cluster IDs: 10.10.1.92, 10.10.3.93, 10.10.4.20
                    10.10.5.20, 198.51.100.254
...

Router# show configuration commit change last 1

Building configuration...
!! IOS XR Configuration 6.1.3
router bgp 65000
neighbor 198.51.100.254                <<< not operational, no AFs etc
  remote-as 65000
  cluster-id 198.51.100.254
!
!
end
```

## Disable Client-to-Client Reflection for Specified Cluster IDs



---

**Note** When the software changes reflection state for a given cluster ID, BGP sends an outbound soft refresh to all clients.

---

```
Router# configure terminal
Router(config)# router bgp 65000
Router(config-bgp)# address-family ipv4 unicast
Router(config-bgp-af)# bgp client-to-client reflection cluster-id 0.0.0.1 disable
Router(config-bgp)# commit
```

### Running Configuration

```
!
router bgp 65000
  address-family ipv4 unicast
    bgp client-to-client reflection cluster-id 0.0.0.1 disable
```

### Verification

The following show command output shows that client-to-client reflection for the cluster IDs has been disabled.

```
Router# show bgp process
BGP Process Information:
BGP is operating in STANDALONE mode
Autonomous System number format: ASPLAIN
Autonomous System: 65000
Router ID: 0.0.0.0
Active Cluster IDs: 0.0.0.1
Fast external fallover enabled
Platform RLIMIT max: 2147483648 bytes
Maximum limit for BMP buffer size: 409 MB
Default value for BMP buffer size: 307 MB
Current limit for BMP buffer size: 307 MB
Current utilization of BMP buffer limit: 0 B
Neighbor logging is enabled
Enforce first AS enabled
Default local preference: 100
Default keepalive: 60
Non-stop routing is enabled
Update delay: 120
Generic scan interval: 60

Address family: IPv4 Unicast
Dampening is not enabled
Client reflection is not enabled in global config
Dynamic MED is Disabled
Dynamic MED interval : 10 minutes
Dynamic MED Timer : Not Running
Dynamic MED Periodic Timer : Not Running
Scan interval: 60
Total prefixes scanned: 0
Prefixes scanned per segment: 100000
Number of scan segments: 1
Nexthop resolution minimum prefix-length: 0 (not configured)
Main Table Version: 2
Table version synced to RIB: 2
Table version acked by RIB: 2
IGP notification: IGP notified
RIB has converged: version 0
RIB table prefix-limit reached ? [No], version 0
Permanent Network Unconfigured

Node          Process      Nbrs Estb Rst Upd-Rcvd Upd-Sent Nfn-Rcv Nfn-Snt
node0_0_CPU0  Speaker      1     0   2         0         0         0         3
```

## How to Implement BGP

### Information About Implementing BGP

To implement BGP, you need to understand the following concepts:

## Adjust BGP Timers

BGP uses certain timers to control periodic activities, such as the sending of keepalive messages and the interval after which a neighbor is assumed to be down if no messages are received from the neighbor during the interval. The values set using the **timers bgp** command in router configuration mode can be overridden on particular neighbors using the **timers** command in the neighbor configuration mode.

Perform this task to set the timers for BGP neighbors.

---

**Step 1** **configure****Example:**

```
RP/0/# configure
Enters mode.
```

**Step 2** **router bgp** *as-number***Example:**

```
Router(config)# router bgp 123
```

Specifies the autonomous system number and enters the BGP configuration mode, allowing you to configure the BGP routing process.

**Step 3** **timers bgp** *keepalive hold-time***Example:**

```
Router(config-bgp)# timers bgp 30 90
```

Sets a default keepalive time and a default hold time for all neighbors.

**Step 4** **neighbor** *ip-address***Example:**

```
Router(config-bgp)# neighbor 172.168.40.24
```

Places the router in neighbor configuration mode for BGP routing and configures the neighbor IP address as a BGP peer.

**Step 5** **timers** *keepalive hold-time***Example:**

```
Router(config-bgp-nbr)# timers 60 220
```

(Optional) Sets the keepalive timer and the hold-time timer for the BGP neighbor.

**Step 6** Use the **commit** or **end** command.

**commit** —Saves the configuration changes and remains within the configuration session.

**end** —Prompts user to take one of these actions:

- **Yes** — Saves configuration changes and exits the configuration session.
- **No** —Exits the configuration session without committing the configuration changes.

- **Cancel** —Remains in the configuration session, without committing the configuration changes.

## Enabling BGP Routing

Perform this task to enable BGP routing and establish a BGP routing process. Configuring BGP neighbors is included as part of enabling BGP routing.



**Note** At least one neighbor and at least one address family must be configured to enable BGP routing. At least one neighbor with both a remote AS and an address family must be configured globally using the **address family** and **remote as** commands.

### Before you begin

BGP must be able to obtain a router identifier (for example, a configured loopback address). At least, one address family must be configured in the BGP router configuration and the same address family must also be configured under the neighbor.



**Note** If the neighbor is configured as an external BGP (eBGP) peer, you must configure an inbound and outbound route policy on the neighbor using the **route-policy** command.



**Note** Instead of configuring an inbound and outbound route policy, you can configure the unsafe eBGP policy to allow all eBGP neighbors to pass routes using the **bgp unsafe-ebgp-policy** command.



**Note** While establishing eBGP neighborhood between two peers, BGP checks if the two peers are directly connected. If the peers are not directly connected, BGP does not try to establish a relationship by default. If two BGP peers are not directly connected and peering is required between the loop backs of the routers, you can use the **ignore-connected-check** command. This command overrides the default check that BGP performs which is to verify if source IP in BGP control packets is in same network as that of destination. In this scenario, a TTL value of 1 is sufficient if **ignore-connected-check** is used.

Configuring **egp-multihop ttl** is needed when the peers are not directly connected and there are more routers in between. If the **egp-multihop ttl** command is not configured, eBGP sets the TTL of packets carrying BGP messages to 1 by default. When eBGP needs to be setup between routers which are more than one hop away, you need to configure a TTL value which is at least equal to the number of hops between them. For example, if there are 2 hops (R2, R3) between two BGP peering routers R1 and R4, you need to set a TTL value of 3.

**Step 1** configure

**Example:**

```
RP/0/# configure
```

Enters mode.

**Step 2**     **route-policy** *route-policy-name*

**Example:**

```
Routing(config)# route-policy drop-as-1234
Routing(config-rpl)# if as-path passes-through '1234' then
Routing(config-rpl)# apply check-communities
Routing(config-rpl)# else
Routing(config-rpl)# pass
Routing(config-rpl)# endif
```

(Optional) Creates a route policy and enters route policy configuration mode, where you can define the route policy.

**Step 3**     **end-policy**

**Example:**

```
Routing(config-rpl)# end-policy
```

(Optional) Ends the definition of a route policy and exits route policy configuration mode.

**Step 4**     Use the **commit** or **end** command.

**commit** —Saves the configuration changes and remains within the configuration session.

**end** —Prompts user to take one of these actions:

- **Yes** — Saves configuration changes and exits the configuration session.
- **No** —Exits the configuration session without committing the configuration changes.
- **Cancel** —Remains in the configuration session, without committing the configuration changes.

**Step 5**     **configure**

**Example:**

```
RP/0/# configure
```

Enters mode.

**Step 6**     **router bgp** *as-number*

**Example:**

```
Routing(config)# router bgp 120
```

Specifies the BGP AS number and enters the BGP configuration mode, allowing you to configure the BGP routing process.

**Step 7**     **bgp router-id** *ip-address*

**Example:**

```
Routing(config-bgp)# bgp router-id 192.168.70.24
```

Configures the local router with a specified router ID.

**Step 8**     **address-family** { **ipv4** | **ipv6** } **unicast**

**Example:**

```
Routing(config-bgp)# address-family ipv4 unicast
```

Specifies either the IPv4 or IPv6 address family and enters address family configuration submode.

To see a list of all the possible keywords and arguments for this command, use the CLI help (?).

**Step 9**     **exit**

**Example:**

```
Routing(config-bgp-af)# exit
```

Exits the current configuration mode.

**Step 10**    **neighbor** *ip-address*

**Example:**

```
Routing(config-bgp)# neighbor 172.168.40.24
```

Places the router in neighbor configuration mode for BGP routing and configures the neighbor IP address as a BGP peer.

**Step 11**    **remote-as** *as-number*

**Example:**

```
Routing(config-bgp-nbr)# remote-as 2002
```

Creates a neighbor and assigns a remote autonomous system number to it.

**Step 12**    **address-family** { **ipv4** | **ipv6** } **unicast**

**Example:**

```
Routing(config-bgp-nbr)# address-family ipv4 unicast
```

Specifies either the IPv4 or IPv6 address family and enters address family configuration submode.

To see a list of all the possible keywords and arguments for this command, use the CLI help (?).

**Step 13**    **route-policy** *route-policy-name* { **in** | **out** }

**Example:**

```
Routing(config-bgp-nbr-af)# route-policy drop-as-1234 in
```

(Optional) Applies the specified policy to inbound IPv4 unicast routes.

**Step 14**    Use the **commit** or **end** command.

**commit** —Saves the configuration changes and remains within the configuration session.

**end** —Prompts user to take one of these actions:

- **Yes** — Saves configuration changes and exits the configuration session.



- **No** —Exits the configuration session without committing the configuration changes.
- **Cancel** —Remains in the configuration session, without committing the configuration changes.

---

## Configure Multiple BGP Instances for a Specific Autonomous System

Perform this task to configure multiple BGP instances for a specific autonomous system. All configuration changes for a single BGP instance can be committed together. However, configuration changes for multiple instances cannot be committed together.

### SUMMARY STEPS

1. **configure**
2. **router bgp** *as-number* [**instance** *instance name*]
3. **bgp router-idip-address**
4. Use the **commit** or **end** command.

### DETAILED STEPS

---

**Step 1** **configure****Example:**

```
RP/0/# configure
```

Enters mode.

**Step 2** **router bgp** *as-number* [**instance** *instance name*]**Example:**

```
RP/0/RSP0/CPU0:router(config)# router bgp 100 instance inst1
```

Enters BGP configuration mode for the user specified BGP instance.

**Step 3** **bgp router-idip-address****Example:**

```
RP/0/RSP0/CPU0:router(config-bgp)# bgp router-id 10.0.0.0
```

Configures a fixed router ID for the BGP-speaking router (BGP instance).

**Note** You must manually configure unique router ID for each BGP instance.

**Step 4** Use the **commit** or **end** command.

**commit** —Saves the configuration changes and remains within the configuration session.

**end** —Prompts user to take one of these actions:

- **Yes** — Saves configuration changes and exits the configuration session.
- **No** —Exits the configuration session without committing the configuration changes.

- **Cancel** —Remains in the configuration session, without committing the configuration changes.

---

## Configure Routing Domain Confederation for BGP

Perform this task to configure the routing domain confederation for BGP. This includes specifying a confederation identifier and autonomous systems that belong to the confederation.

Configuring a routing domain confederation reduces the internal BGP (iBGP) mesh by dividing an autonomous system into multiple autonomous systems and grouping them into a single confederation. Each autonomous system is fully meshed within itself and has a few connections to another autonomous system in the same confederation. The confederation maintains the next hop and local preference information, and that allows you to retain a single Interior Gateway Protocol (IGP) for all autonomous systems. To the outside world, the confederation looks like a single autonomous system.

---

### Step 1 **configure**

**Example:**

```
RP/0/# configure
```

Enters mode.

### Step 2 **router bgp** *as-number*

**Example:**

```
Router# router bgp 120
```

Specifies the autonomous system number and enters the BGP configuration mode, allowing you to configure the BGP routing process.

### Step 3 **bgp confederation identifier** *as-number*

**Example:**

```
Router(config-bgp)# bgp confederation identifier 5
```

Specifies a BGP confederation identifier.

### Step 4 **bgp confederation peers** *as-number*

**Example:**

```
Router(config-bgp)# bgp confederation peers 1091
Router(config-bgp)# bgp confederation peers 1092
Router(config-bgp)# bgp confederation peers 1093
Router(config-bgp)# bgp confederation peers 1094
Router(config-bgp)# bgp confederation peers 1095
Router(config-bgp)# bgp confederation peers 1096
```

Specifies that the BGP autonomous systems belong to a specified BGP confederation identifier. You can associate multiple AS numbers to the same confederation identifier, as shown in the example.

### Step 5 Use the **commit** or **end** command.

**commit** —Saves the configuration changes and remains within the configuration session.

**end** —Prompts user to take one of these actions:

- **Yes** — Saves configuration changes and exits the configuration session.
- **No** —Exits the configuration session without committing the configuration changes.
- **Cancel** —Remains in the configuration session, without committing the configuration changes.

---

### BGP Confederation: Example

The following is a sample configuration that shows several peers in a confederation. The confederation consists of three internal autonomous systems with autonomous system numbers 6001, 6002, and 6003. To the BGP speakers outside the confederation, the confederation looks like a normal autonomous system with autonomous system number 666 (specified using the **bgp confederation identifier** command).

In a BGP speaker in autonomous system 6001, the **bgp confederation peers** command marks the peers from autonomous systems 6002 and 6003 as special eBGP peers. Hence, peers 171.16.232.55 and 171.16.232.56 get the local preference, next hop, and MED unmodified in the updates. The router at 171.19.69.1 is a normal eBGP speaker, and the updates received by it from this peer are just like a normal eBGP update from a peer in autonomous system 666.

```
router bgp 6001
  bgp confederation identifier 666
  bgp confederation peers
    6002
    6003
  exit
  address-family ipv4 unicast
    neighbor 171.16.232.55
    remote-as 6002
  exit
  address-family ipv4 unicast
    neighbor 171.16.232.56
    remote-as 6003
  exit
  address-family ipv4 unicast
    neighbor 171.19.69.1
    remote-as 777
```

In a BGP speaker in autonomous system 6002, the peers from autonomous systems 6001 and 6003 are configured as special eBGP peers. Peer 171.17.70.1 is a normal iBGP peer, and peer 199.99.99.2 is a normal eBGP peer from autonomous system 700.

```
router bgp 6002
  bgp confederation identifier 666
  bgp confederation peers
    6001
    6003
  exit
  address-family ipv4 unicast
    neighbor 171.17.70.1
```

```

    remote-as 6002
    exit
address-family ipv4 unicast
neighbor 171.19.232.57
    remote-as 6001
    exit
address-family ipv4 unicast
neighbor 171.19.232.56
    remote-as 6003
    exit
address-family ipv4 unicast
neighbor 171.19.99.2
    remote-as 700
    exit
address-family ipv4 unicast
route-policy pass-all in
route-policy pass-all out

```

In a BGP speaker in autonomous system 6003, the peers from autonomous systems 6001 and 6002 are configured as special eBGP peers. Peer 192.168.200.200 is a normal eBGP peer from autonomous system 701.

```

router bgp 6003
bgp confederation identifier 666
bgp confederation peers
6001
6002
    exit
address-family ipv4 unicast
neighbor 171.19.232.57
    remote-as 6001
    exit
address-family ipv4 unicast
neighbor 171.19.232.55
    remote-as 6002
    exit
address-family ipv4 unicast
neighbor 192.168.200.200
    remote-as 701
    exit
address-family ipv4 unicast
route-policy pass-all in
route-policy pass-all out

```

The following is a part of the configuration from the BGP speaker 192.168.200.205 from autonomous system 701 in the same example. Neighbor 171.16.232.56 is configured as a normal eBGP speaker from autonomous system 666. The internal division of the autonomous system into multiple autonomous systems is not known to the peers external to the confederation.

```

router bgp 701
address-family ipv4 unicast
neighbor 172.16.232.56
    remote-as 666
    exit
address-family ipv4 unicast
route-policy pass-all in
route-policy pass-all out
    exit

```

```
address-family ipv4 unicast
neighbor 192.168.200.205
remote-as 701
```

## Resetting an eBGP Session Immediately Upon Link Failure

By default, if a link goes down, all BGP sessions of any directly adjacent external peers are immediately reset. Use the **bgp fast-external-fallover disable** command to disable automatic resetting. Turn the automatic reset back on using the **no bgp fast-external-fallover disable** command.

eBGP sessions flap when the node reaches 3500 eBGP sessions with BGP timer values set as 10 and 30. To support more than 3500 eBGP sessions, increase the packet rate by using the **lpts pifib hardware police location** *location-id* command. Following is a sample configuration to increase the eBGP sessions:

```
Router# configure
Router(config)# lpts pifib hardware police location 0/2/CPU0
Router(config-pifib-policer-per-node)#flow bgp configured rate 4000
Router(config-pifib-policer-per-node)#flow bgp known rate 4000
Router(config-pifib-policer-per-node)#flow bgp default rate 4000
Router(config-pifib-policer-per-node)#commit
```

## Logging Neighbor Changes

Logging neighbor changes is enabled by default. Use the **log neighbor changes disable** command to turn off logging. The **no log neighbor changes disable** command can also be used to turn logging back on if it has been disabled.

## Change BGP Default Local Preference Value

Perform this task to set the default local preference value for BGP paths.

---

### Step 1 **configure**

#### Example:

```
RP/0/# configure
Enters mode.
```

### Step 2 **router bgp** *as-number*

#### Example:

```
Router(config)# router bgp 120
```

Specifies the autonomous system number and enters the BGP configuration mode, allowing you to configure the BGP routing process.

### Step 3 **bgp default local-preference** *value*

#### Example:

```
Router(config-bgp)# bgp default local-preference 200
```

Sets the default local preference value from the default of 100, making it either a more preferable path (over 100) or less preferable path (under 100).

**Step 4** Use the **commit** or **end** command.

**commit** —Saves the configuration changes and remains within the configuration session.

**end** —Prompts user to take one of these actions:

- **Yes** — Saves configuration changes and exits the configuration session.
- **No** —Exits the configuration session without committing the configuration changes.
- **Cancel** —Remains in the configuration session, without committing the configuration changes.

## Configure MED Metric for BGP

Perform this task to set the multi exit discriminator (MED) to advertise to peers for routes that do not already have a metric set (routes that were received with no MED attribute).

**Step 1** **configure**

**Example:**

```
RP/0/# configure
```

Enters mode.

**Step 2** **router bgp** *as-number*

**Example:**

```
Routing(config)# router bgp 120
```

Specifies the autonomous system number and enters the BGP configuration mode, allowing you to configure the BGP routing process.

**Step 3** **default-metric** *value*

**Example:**

```
Routing(config-bgp)# default metric 10
```

Sets the default metric, which is used to set the MED to advertise to peers for routes that do not already have a metric set (routes that were received with no MED attribute).

**Step 4** Use the **commit** or **end** command.

**commit** —Saves the configuration changes and remains within the configuration session.

**end** —Prompts user to take one of these actions:

- **Yes** — Saves configuration changes and exits the configuration session.

- **No** —Exits the configuration session without committing the configuration changes.
- **Cancel** —Remains in the configuration session, without committing the configuration changes.

---

## Configure BGP Weights

A weight is a number that you can assign to a path so that you can control the best-path selection process. If you have particular neighbors that you want to prefer for most of your traffic, you can use the **weight** command to assign a higher weight to all routes learned from that neighbor. Perform this task to assign a weight to routes received from a neighbor.

---

### Step 1 **configure**

**Example:**

```
RP/0/# configure
Enters mode.
```

### Step 2 **router bgp** *as-number*

**Example:**

```
Routing(config)# router bgp 120
```

Specifies the autonomous system number and enters the BGP configuration mode, allowing you to configure the BGP routing process.

### Step 3 **neighbor** *ip-address*

**Example:**

```
Routing(config-bgp)# neighbor 172.168.40.24
```

Places the router in neighbor configuration mode for BGP routing and configures the neighbor IP address as a BGP peer.

### Step 4 **remote-as** *as-number*

**Example:**

```
Routing(config-bgp-nbr)# remote-as 2002
```

Creates a neighbor and assigns a remote autonomous system number to it.

### Step 5 **address-family** { **ipv4** | **ipv6** } **unicast**

**Example:**

```
Routing(config-bgp-nbr)# address-family ipv4 unicast
```

Specifies either the IPv4 or IPv6 address family and enters address family configuration submode.

To see a list of all the possible keywords and arguments for this command, use the CLI help (?).

### Step 6 **weight** *weight-value*

**Example:**

```
Routing(config-bgp-nbr-af)# weight 41150
```

Assigns a weight to all routes learned through the neighbor.

**Step 7** Use the **commit** or **end** command.

**commit** —Saves the configuration changes and remains within the configuration session.

**end** —Prompts user to take one of these actions:

- **Yes** — Saves configuration changes and exits the configuration session.
- **No** —Exits the configuration session without committing the configuration changes.
- **Cancel** —Remains in the configuration session, without committing the configuration changes.

**What to do next**

You the **clear bgp** command for the newly configured weight to take effect.

## Tune BGP Best-Path Calculation

BGP routers typically receive multiple paths to the same destination. The BGP best-path algorithm determines the best path to install in the IP routing table and to use for forwarding traffic. The BGP best-path comprises of three steps:

- Step 1—Compare two paths to determine which is better.
- Step 2—Iterate over all paths and determines which order to compare the paths to select the overall best path.
- Step 3—Determine whether the old and new best paths differ enough so that the new best path should be used.



**Note** The order of comparison determined by Step 2 is important because the comparison operation is not transitive; that is, if three paths, A, B, and C exist, such that when A and B are compared, A is better, and when B and C are compared, B is better, it is not necessarily the case that when A and C are compared, A is better. This nontransitivity arises because the multi exit discriminator (MED) is compared only among paths from the same neighboring autonomous system (AS) and not among all paths.

Perform this task to change the default BGP best-path calculation behavior.

**Step 1** **configure**

**Example:**

```
RP/0/# configure
```



Enters mode.

**Step 2** `router bgp as-number`

**Example:**

```
Router(config)# router bgp 126
```

Specifies the autonomous system number and enters the BGP configuration mode, allowing you to configure the BGP routing process.

**Step 3** `bgp bestpath med missing-as-worst`

**Example:**

```
Router(config-bgp)# bgp bestpath med missing-as-worst
```

Directs the BGP software to consider a missing MED attribute in a path as having a value of infinity, making this path the least desirable path.

**Step 4** `bgp bestpath med always`

**Example:**

```
Router(config-bgp)# bgp bestpath med always
```

Configures the BGP speaker in the specified autonomous system to compare MEDs among all the paths for the prefix, regardless of the autonomous system from which the paths are received.

**Step 5** `bgp bestpath med confed`

**Example:**

```
Router(config-bgp)# bgp bestpath med confed
```

Enables BGP software to compare MED values for paths learned from confederation peers.

**Step 6** `bgp bestpath as-path ignore`

**Example:**

```
Router(config-bgp)# bgp bestpath as-path ignore
```

Configures the BGP software to ignore the autonomous system length when performing best-path selection.

**Step 7** `bgp bestpath compare-routerid`

**Example:**

```
Router(config-bgp)# bgp bestpath compare-routerid
```

Configure the BGP speaker in the autonomous system to compare the router IDs of similar paths.

**Step 8** Use the `commit` or `end` command.

**commit** —Saves the configuration changes and remains within the configuration session.

**end** —Prompts user to take one of these actions:

- **Yes** — Saves configuration changes and exits the configuration session.
- **No** —Exits the configuration session without committing the configuration changes.

- **Cancel** —Remains in the configuration session, without committing the configuration changes.

## Configure Aggregate Addresses

Perform this task to create aggregate entries in a BGP routing table.



- Note** For optimal CPU utilization when deploying BGP aggregate for supernet addresses with a higher scale such as internet bgp table, it is recommended to:
- Use aggregate subnet of size not exceeding /24.
  - Tune the subnet mask size based on network scale and churn.
  - Use the **default-originate** or **network** 0.0.0.0 CLI instead of 0.0.0.0 as aggregate, when advertising the default route 0.0.0.0.

### Step 1 **configure**

**Example:**

```
RP/0/# configure
```

Enters mode.

### Step 2 **router bgp *as-number***

**Example:**

```
Router(config)# router bgp 120
```

Specifies the autonomous system number and enters the BGP configuration mode, allowing you to configure the BGP routing process.

### Step 3 **address-family { *ipv4* | *ipv6* } *unicast***

**Example:**

```
Router(config-bgp)# address-family ipv4 unicast
```

Specifies either the IPv4 or IPv6 address family and enters address family configuration submode.

To see a list of all the possible keywords and arguments for this command, use the CLI help (?).

### Step 4 **aggregate-address *address/mask-length* [ *as-set* ] [ *as-confed-set* ] [ *summary-only* ] [ *route-policy route-policy-name* ]**

**Example:**

```
Router(config-bgp-af)# aggregate-address 10.0.0.0/8 as-set
```

Creates an aggregate address. The path advertised for this route is an autonomous system set consisting of all elements contained in all paths that are being summarized.

- The **as-set** keyword generates autonomous system set path information and community information from contributing paths.
- The **as-confed-set** keyword generates autonomous system confederation set path information from contributing paths.
- The **summary-only** keyword filters all more specific routes from updates.
- The **route-policy** *route-policy-name* keyword and argument specify the route policy used to set the attributes of the aggregate route.

**Step 5** Use the **commit** or **end** command.

**commit** —Saves the configuration changes and remains within the configuration session.

**end** —Prompts user to take one of these actions:

- **Yes** — Saves configuration changes and exits the configuration session.
- **No** —Exits the configuration session without committing the configuration changes.
- **Cancel** —Remains in the configuration session, without committing the configuration changes.

## Indicate BGP Back-door Routes

Perform this task to set the administrative distance on an external Border Gateway Protocol (eBGP) route to that of a locally sourced BGP route, causing it to be less preferred than an Interior Gateway Protocol (IGP) route.

**Step 1** **configure**

**Example:**

```
RP/0/# configure
```

Enters mode.

**Step 2** **router bgp** *as-number*

**Example:**

```
Router(config)# router bgp 120
```

Specifies the autonomous system number and enters the BGP configuration mode, allowing you to configure the BGP routing process.

**Step 3** **address-family** { **ipv4** | **ipv6** } **unicast**

**Example:**

```
Router(config-bgp)# address-family ipv4 unicast
```

Specifies either the IPv4 or IPv6 address family and enters address family configuration submenu.

To see a list of all the possible keywords and arguments for this command, use the CLI help (?).

**Step 4** **network** { *ip-address / prefix-length* | *ip-address mask* } **backdoor**

**Example:**

```
Router(config-bgp-af)# network 172.20.0.0/16
```

Configures the local router to originate and advertise the specified network.

**Step 5** Use the **commit** or **end** command.

**commit** —Saves the configuration changes and remains within the configuration session.

**end** —Prompts user to take one of these actions:

- **Yes** — Saves configuration changes and exits the configuration session.
- **No** —Exits the configuration session without committing the configuration changes.
- **Cancel** —Remains in the configuration session, without committing the configuration changes.

### Back Door: Example

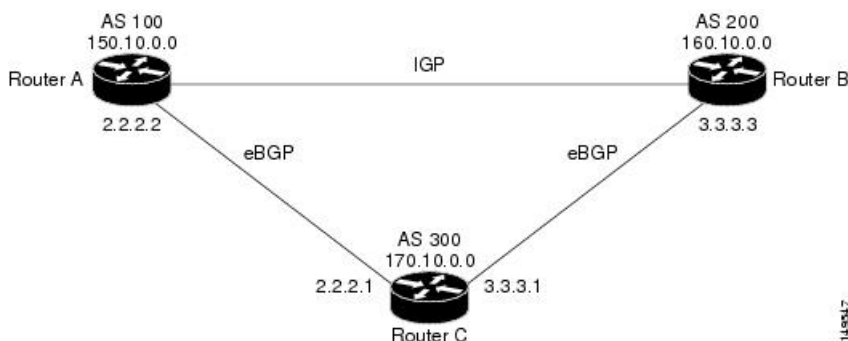

Here, Routers A and C and Routers B and C are running eBGP. Routers A and B are running an IGP (such as Routing Information Protocol [RIP], Interior Gateway Routing Protocol [IGRP], Enhanced IGRP, or Open Shortest Path First [OSPF]). The default distances for RIP, IGRP, Enhanced IGRP, and OSPF are 120, 100, 90, and 110, respectively. All these distances are higher than the default distance of eBGP, which is 20. Usually, the route with the lowest distance is preferred.

Router A receives updates about 160.10.0.0 from two routing protocols: eBGP and IGP. Because the default distance for eBGP is lower than the default distance of the IGP, Router A chooses the eBGP-learned route from Router C. If you want Router A to learn about 160.10.0.0 from Router B (IGP), establish a BGP back door. See .

In the following example, a network back-door is configured:

```
Router(config)# router bgp 100
Router(config-bgp)# address-family ipv4 unicast
Router(config-bgp-af)# network 160.10.0.0/16 backdoor
```

Router A treats the eBGP-learned route as local and installs it in the IP routing table with a distance of 200. The network is also learned through Enhanced IGRP (with a distance of 90), so the Enhanced IGRP route is successfully installed in the IP routing table and is used to forward traffic. If the

Enhanced IGRP-learned route goes down, the eBGP-learned route is installed in the IP routing table and is used to forward traffic.

Although BGP treats network 160.10.0.0 as a local entry, it does not advertise network 160.10.0.0 as it normally would advertise a local entry.

## Set BGP Administrative Distance

An administrative distance is a rating of the trustworthiness of a routing information source. In general, the higher the value, the lower the trust rating. Normally, a route can be learned through more than one protocol. Administrative distance is used to discriminate between routes learned from more than one protocol. The route with the lowest administrative distance is installed in the IP routing table. By default, BGP uses the administrative distances shown in here:

**Table 10: BGP Default Administrative Distances**

Distance	Default Value	Function
External	20	Applied to routes learned from eBGP.
Internal	200	Applied to routes learned from iBGP.
Local	200	Applied to routes originated by the router.



**Note** Distance does not influence the BGP path selection algorithm, but it does influence whether BGP-learned routes are installed in the IP routing table.

Perform this task to specify the use of administrative distances that can be used to prefer one class of route over another.

**Step 1** **configure**

**Step 2** **router bgp** *as-number*

**Example:**

```
Router(config)# router bgp 120
```

Specifies the autonomous system number and enters the BGP configuration mode, allowing you to configure the BGP routing process.

**Step 3** **address-family** { **ipv4** | **ipv6** } **unicast**

**Example:**

```
Router(config-bgp)# address-family ipv4 unicast
```

Specifies either an IPv4 or IPv6 address family unicast and enters address family configuration submode.

To see a list of all the possible keywords and arguments for this command, use the CLI help (?).

**Step 4** **distance bgp** *external-distance internal-distance local-distance*

**Example:**

```
Router(config-bgp-af)# distance bgp 20 20 200
```

Sets the external, internal, and local administrative distances to prefer one class of routes over another. The higher the value, the lower the trust rating.

**Step 5** Use the **commit** or **end** command.

**commit** —Saves the configuration changes and remains within the configuration session.

**end** —Prompts user to take one of these actions:

- **Yes** — Saves configuration changes and exits the configuration session.
- **No** —Exits the configuration session without committing the configuration changes.
- **Cancel** —Remains in the configuration session, without committing the configuration changes.

## Configure BGP Neighbor Group and Neighbors

Perform this task to configure BGP neighbor groups and apply the neighbor group configuration to a neighbor. A neighbor group is a template that holds address family-independent and address family-dependent configurations associated with the neighbor.

After a neighbor group is configured, each neighbor can inherit the configuration through the **use** command. If a neighbor is configured to use a neighbor group, the neighbor (by default) inherits the entire configuration of the neighbor group, which includes the address family-independent and address family-dependent configurations. The inherited configuration can be overridden if you directly configure commands for the neighbor or configure session groups or address family groups through the **use** command.

You can configure an address family-independent configuration under the neighbor group. An address family-dependent configuration requires you to configure the address family under the neighbor group to enter address family submode. From neighbor group configuration mode, you can configure address family-independent parameters for the neighbor group. Use the **address-family** command when in the neighbor group configuration mode. After specifying the neighbor group name using the **neighbor group** command, you can assign options to the neighbor group.



**Note** All commands that can be configured under a specified neighbor group can be configured under a neighbor.

**Step 1** **configure**

**Example:**

```
RP/0/# configure
```

Enters mode.

**Step 2** **router bgp** *as-number*

**Example:**

```
Router(config)# router bgp 120
```

Specifies the autonomous system number and enters the BGP configuration mode, allowing you to configure the BGP routing process.

**Step 3**     **address-family { ipv4 | ipv6 } unicast**

**Example:**

```
Router(config-bgp)# address-family ipv4 unicast
```

Specifies either an IPv4 or IPv6 address family unicast and enters address family configuration submode.

To see a list of all the possible keywords and arguments for this command, use the CLI help (?).

**Step 4**     **exit**

**Example:**

```
Router(config-bgp-af)# exit
```

Exits the current configuration mode.

**Step 5**     **neighbor-group name**

**Example:**

```
Router(config-bgp)# neighbor-group nbr-grp-A
```

Places the router in neighbor group configuration mode.

**Step 6**     **remote-as as-number**

**Example:**

```
Router(config-bgp-nbrgrp)# remote-as 2002
```

Creates a neighbor and assigns a remote autonomous system number to it.

**Step 7**     **address-family { ipv4 | ipv6 } unicast**

**Example:**

```
Router(config-bgp-nbrgrp)# address-family ipv4 unicast
```

Specifies either an IPv4 or IPv6 address family unicast and enters address family configuration submode.

To see a list of all the possible keywords and arguments for this command, use the CLI help (?).

**Step 8**     **route-policy route-policy-name { in | out }**

**Example:**

```
Router(config-bgp-nbrgrp-af)# route-policy drop-as-1234 in
```

(Optional) Applies the specified policy to inbound IPv4 unicast routes.

**Step 9**     **exit**

**Example:**

```
Router(config-bgp-nbrgrp-af)# exit
```

Exits the current configuration mode.

**Step 10**    **exit**

**Example:**

```
Router(config-bgp-nbrgrp)# exit
```

Exits the current configuration mode.

**Step 11**    **neighbor** *ip-address*

**Example:**

```
Router(config-bgp)# neighbor 172.168.40.24
```

Places the router in neighbor configuration mode for BGP routing and configures the neighbor IP address as a BGP peer.

**Step 12**    **use neighbor-group** *group-name*

**Example:**

```
Router(config-bgp-nbr)# use neighbor-group nbr-grp-A
```

(Optional) Specifies that the BGP neighbor inherit configuration from the specified neighbor group.

**Step 13**    **remote-as** *as-number*

**Example:**

```
Router(config-bgp-nbr)# remote-as 2002
```

Creates a neighbor and assigns a remote autonomous system number to it.

**Step 14**    Use the **commit** or **end** command.

**commit** —Saves the configuration changes and remains within the configuration session.

**end** —Prompts user to take one of these actions:

- **Yes** — Saves configuration changes and exits the configuration session.
- **No** —Exits the configuration session without committing the configuration changes.
- **Cancel** —Remains in the configuration session, without committing the configuration changes.

### BGP Neighbor Configuration: Example

The following example shows how BGP neighbors on an autonomous system are configured to share information. In the example, a BGP router is assigned to autonomous system 109, and two networks are listed as originating in the autonomous system. Then the addresses of three remote routers (and their autonomous systems) are listed. The router being configured shares information about networks 172.16.0.0 and 192.168.7.0 with the neighbor routers. The first router listed is in a different autonomous system; the second **neighbor** and **remote-as** commands specify an internal neighbor (with the same autonomous system number) at address 172.26.234.2; and the third **neighbor** and **remote-as** commands specify a neighbor on a different autonomous system.

```
route-policy pass-all
  pass
end-policy
router bgp 109
  address-family ipv4 unicast
    network 172.16.0.0 255.255.0.0
    network 192.16831.7.0 255.255.0.0
```



```
neighbor 172.16.200.1
  remote-as 167
  exit
address-family ipv4 unicast
  route-policy pass-all in
  route-policy pass-out out
neighbor 172.26.234.2
  remote-as 109
  exit
address-family ipv4 unicast
neighbor 172.26.64.19
  remote-as 99
  exit
address-family ipv4 unicast
  route-policy pass-all in
  route-policy pass-all out
```

## Configure Route Reflector for BGP

Perform this task to configure a route reflector for BGP.

All the neighbors configured with the **route-reflector-client** command are members of the client group, and the remaining iBGP peers are members of the nonclient group for the local route reflector.

Together, a route reflector and its clients form a *cluster*. A cluster of clients usually has a single route reflector. In such instances, the cluster is identified by the software as the router ID of the route reflector. To increase redundancy and avoid a single point of failure in the network, a cluster can have more than one route reflector. If it does, all route reflectors in the cluster must be configured with the same 4-byte cluster ID so that a route reflector can recognize updates from route reflectors in the same cluster. The **bgp cluster-id** command is used to configure the cluster ID when the cluster has more than one route reflector.

The **bgp cluster-id** option is used in this task to configure the router as one of the route reflectors serving the cluster. The **cluster-id** option is also available in the BGP neighbor address-family (config-bgp-nbr-af) mode. To enable a router to accept BGP routes which have the same first cluster-ID as the router's own cluster-ID in the list of cluster-IDs, use the **cluster-id allow-equal** command. You must use this command with care to avoid routing loops.

---

### Step 1 configure

#### Example:

```
RP/0/# configure
```

Enters mode.

### Step 2 router bgp *as-number*

#### Example:

```
Router(config)# router bgp 120
```

Specifies the autonomous system number and enters the BGP configuration mode, allowing you to configure the BGP routing process.

### Step 3 bgp cluster-id *cluster-id*

#### Example:

```
Router(config-bgp)# bgp cluster-id 192.168.70.1
```

Configures the local router as one of the route reflectors serving the cluster. It is configured with a specified cluster ID to identify the cluster.

**Step 4** **neighbor** *ip-address*

**Example:**

```
Router(config-bgp)# neighbor 172.168.40.24
```

Places the router in neighbor configuration mode for BGP routing and configures the neighbor IP address as a BGP peer.

**Step 5** **remote-as** *as-number*

**Example:**

```
Router(config-bgp-nbr)# remote-as 2003
```

Creates a neighbor and assigns a remote autonomous system number to it.

**Step 6** **address-family** { **ipv4** | **ipv6** } **unicast**

**Example:**

```
Router(config-nbr)# address-family ipv4 unicast
```

Specifies either an IPv4 or IPv6 address family unicast and enters address family configuration submode.

To see a list of all the possible keywords and arguments for this command, use the CLI help (?).

**Step 7** **route-reflector-client**

**Example:**

```
Router(config-bgp-nbr-af)# route-reflector-client
```

Configures the router as a BGP route reflector and configures the neighbor as its client.

**Step 8** Use the **commit** or **end** command.

**commit** —Saves the configuration changes and remains within the configuration session.

**end** —Prompts user to take one of these actions:

- **Yes** — Saves configuration changes and exits the configuration session.
- **No** —Exits the configuration session without committing the configuration changes.
- **Cancel** —Remains in the configuration session, without committing the configuration changes.

### BGP Route Reflector: Example

The following example shows how to use an address family to configure internal BGP peer 10.1.1.1 as a route reflector client for unicast prefixes:

```
router bgp 140
 address-family ipv4 unicast
  neighbor 10.1.1.1
  remote-as 140
 address-family ipv4 unicast
```

```
route-reflector-client
exit
```

## Understanding BGP MD5 Authentication

BGP provides a mechanism, known as Message Digest 5 (MD5) authentication, for authenticating a TCP segment between two BGP peers by using a clear text or encrypted password.

MD5 authentication is configured at the BGP neighbor level. BGP peers using MD5 authentication are configured with the same password. If the password authentication fails, then the packets are not transmitted along the segment.

## Redistributing iBGP Routes into IGP

Perform this task to redistribute iBGP routes into an Interior Gateway Protocol (IGP), such as Intermediate System-to-Intermediate System (IS-IS) or Open Shortest Path First (OSPF).



**Note** Use of the **bgp redistribute-internal** command requires the **clear route \*** command to be issued to reinstall all BGP routes into the IP routing table.



**Caution** Redistributing iBGP routes into IGPs may cause routing loops to form within an autonomous system. Use this command with caution.

### Procedure

	Command or Action	Purpose
Step 1	<b>configure</b>	
Step 2	<b>router bgp</b> <i>as-number</i> <b>Example:</b> Router(config)# router bgp 120	Specifies the autonomous system number and enters the BGP configuration mode, allowing you to configure the BGP routing process.
Step 3	<b>bgp redistribute-internal</b> <b>Example:</b> Router(config-bgp)# bgp redistribute-internal	Allows the redistribution of iBGP routes into an IGP, such as IS-IS or OSPF.
Step 4	<b>commit</b>	

## Set BGP Administrative Distance

An administrative distance is a rating of the trustworthiness of a routing information source. In general, the higher the value, the lower the trust rating. Normally, a route can be learned through more than one protocol.

Administrative distance is used to discriminate between routes learned from more than one protocol. The route with the lowest administrative distance is installed in the IP routing table. By default, BGP uses the administrative distances shown in here:

**Table 11: BGP Default Administrative Distances**

Distance	Default Value	Function
External	20	Applied to routes learned from eBGP.
Internal	200	Applied to routes learned from iBGP.
Local	200	Applied to routes originated by the router.



**Note** Distance does not influence the BGP path selection algorithm, but it does influence whether BGP-learned routes are installed in the IP routing table.

Perform this task to specify the use of administrative distances that can be used to prefer one class of route over another.

**Step 1** **configure**

**Step 2** **router bgp** *as-number*

**Example:**

```
Router(config)# router bgp 120
```

Specifies the autonomous system number and enters the BGP configuration mode, allowing you to configure the BGP routing process.

**Step 3** **address-family { ipv4 | ipv6 } unicast**

**Example:**

```
Router(config-bgp)# address-family ipv4 unicast
```

Specifies either an IPv4 or IPv6 address family unicast and enters address family configuration submode.

To see a list of all the possible keywords and arguments for this command, use the CLI help (?).

**Step 4** **distance bgp** *external-distance internal-distance local-distance*

**Example:**

```
Router(config-bgp-af)# distance bgp 20 20 200
```

Sets the external, internal, and local administrative distances to prefer one class of routes over another. The higher the value, the lower the trust rating.

**Step 5** Use the **commit** or **end** command.

**commit** —Saves the configuration changes and remains within the configuration session.

**end** —Prompts user to take one of these actions:

- **Yes** — Saves configuration changes and exits the configuration session.
- **No** —Exits the configuration session without committing the configuration changes.
- **Cancel** —Remains in the configuration session, without committing the configuration changes.

## Configuring Discard Extra Paths

Perform this task to configure BGP maximum-prefix discard extra paths.

### Procedure

	Command or Action	Purpose
Step 1	<b>configure</b> <b>Example:</b> Router# configure	Enters Global configuration mode.
Step 2	<b>router bgp</b> <i>as-number</i> <b>Example:</b> Router(config)# router bgp 10	Specifies the autonomous system number and enters the BGP configuration mode, allowing you to configure the BGP routing process.
Step 3	<b>neighbor</b> <i>ip-address</i> <b>Example:</b> Router(config-bgp)# neighbor 10.0.0.1	Places the router in neighbor configuration mode for BGP routing and configures the neighbor IP address as a BGP peer.
Step 4	<b>address-family</b> { <i>ipv4</i>   <i>ipv6</i> } <b>unicast</b> <b>Example:</b> Router(config-bgp-nbr)# address-family ipv4 unicast	Specifies either the IPv4 or IPv6 address family and enters address family configuration submenu.
Step 5	<b>maximum-prefix</b> <i>maximum</i> <b>discard-extra-paths</b> <b>Example:</b> Router(config-bgp-nbr-af)# maximum-prefix 1000 discard-extra-paths	Configures a limit to the number of prefixes allowed. Configures discard extra paths to discard extra paths when the maximum prefix limit is exceeded.
Step 6	Use the <b>commit</b> or <b>end</b> command.	<b>commit</b> —Saves the configuration changes and remains within the configuration session. <b>end</b> —Prompts user to take one of these actions: <ul style="list-style-type: none"> <li>• <b>Yes</b> — Saves configuration changes and exits the configuration session.</li> <li>• <b>No</b> —Exits the configuration session without committing the configuration changes.</li> <li>• <b>Cancel</b> —Remains in the configuration session, without committing the configuration changes.</li> </ul>

## Configuring Per Neighbor TCP MSS

Perform this task to configure TCP MSS under neighbor group, which is inherited by a neighbor.

---

**Step 1**     **configure****Example:**

```
Router# configure
Enters .
```

**Step 2**     **router bgp** *as-number***Example:**

```
Router(config)# router bgp 10
```

Specifies the autonomous system number and enters the BGP configuration mode, allowing you to configure the BGP routing process.

**Step 3**     **address-family ipv4 unicast****Example:**

```
Router(config-bgp)# address-family ipv4 unicast
```

Specifies the IPv4 address family unicast and enters address family configuration mode.

**Step 4**     **exit****Example:**

```
Router(config-bgp-af)# exit
```

Exits router address family configuration mode, and returns to BGP configuration mode.

**Step 5**     **neighbor-group** *name***Example:**

```
Router(config-bgp)# neighbor-group n1
```

Enters neighbor group configuration mode.

**Step 6**     **tcp mss** *segment-size***Example:**

```
Router(config-bgp-nbrgrp)# tcp mss 500
```

Configures TCP maximum segment size. The range is from 68 to 10000.

**Step 7**     **address-family ipv4 unicast****Example:**

```
Router(config-bgp-nbrgrp)# address-family ipv4 unicast
```

Specifies the IPv4 address family unicast and enters address family configuration mode.

**Step 8**     **exit****Example:**

```
Router(config-bgp-nbrgrp-af)# exit
```

Exits router address family configuration mode.

**Step 9**     **exit**

**Example:**

```
Router(config-bgp-nbrgrp)# exit
```

Exits the neighbor group configuration mode.

**Step 10**    **neighbor ip-address**

**Example:**

```
Router(config-bgp)# neighbor 10.0.0.2
```

Places the router in neighbor configuration mode for BGP routing and configures the neighbor IP address as a BGP peer.

**Step 11**    **remote-as as-number**

**Example:**

```
Router(config-bgp-nbr)# remote-as 1
```

Creates a neighbor and assigns a remote autonomous system (AS) number to it.

- Range for 2-byte autonomous system numbers (ASNs) is 1 to 65535.
- Range for 4-byte autonomous system numbers (ASNs) in asplain format is 1 to 4294967295.
- Range for 4-byte autonomous system numbers (ASNs) in asdot format is 1.0 to 65535.65535.

**Step 12**    **use neighbor-group group-name**

**Example:**

```
Router(config-bgp-nbr)# use neighbor-group n1
```

Specifies that the BGP neighbor inherit configuration from the specified neighbor group.

**Step 13**    **address-family ipv4 unicast**

**Example:**

```
Router(config-bgp-nbr)# address-family ipv4 unicast
```

```
Router(config-bgp-nbr-af)#
```

Specifies the IPv4 address family unicast and enters address family configuration mode.

**Step 14**    Use the **commit** or **end** command.

**commit** —Saves the configuration changes and remains within the configuration session.

**end** —Prompts user to take one of these actions:

- **Yes** — Saves configuration changes and exits the configuration session.
- **No** —Exits the configuration session without committing the configuration changes.
- **Cancel** —Remains in the configuration session, without committing the configuration changes.

# Disabling Per Neighbor TCP MSS

Perform this task to disable TCP MSS for a particular neighbor under neighbor group.

---

**Step 1**     **configure****Example:**

```
Router# configure
```

**Step 2**     **router bgp** *as-number***Example:**

```
Router(config)# router bgp 10
```

Specifies the autonomous system number and enters the BGP configuration mode, allowing you to configure the BGP routing process.

**Step 3**     **address-family ipv4 unicast****Example:**

```
Router(config-bgp)# address-family ipv4 unicast
```

Specifies the IPv4 address family unicast and enters address family configuration mode.

**Step 4**     **exit****Example:**

```
Router(config-bgp-af)# exit
```

Exits router address family configuration mode, and returns to BGP configuration mode.

**Step 5**     **neighbor-group** *name***Example:**

```
Router(config-bgp)# neighbor-group n1
```

Enters neighbor group configuration mode.

**Step 6**     **tcp mss** *segment-size***Example:**

```
Router(config-bgp-nbrgrp)# tcp mss 500
```

Configures TCP maximum segment size. The range is from 68 to 10000.

**Step 7**     **address-family ipv4 unicast****Example:**

```
Router(config-bgp-nbrgrp)# address-family ipv4 unicast
```

Specifies the IPv4 address family unicast and enters address family configuration mode.

**Step 8**     **exit****Example:**



```
Router(config-bgp-nbrgrp-af)# exit
```

Exits router address family configuration mode.

**Step 9**     **exit**

**Example:**

```
Router(config-bgp-nbrgrp)# exit
```

Exits the neighbor group configuration mode.

**Step 10**    **neighbor ip-address**

**Example:**

```
Router(config-bgp)# neighbor 10.0.0.2
```

Places the router in neighbor configuration mode for BGP routing and configures the neighbor IP address as a BGP peer.

**Step 11**    **remote-as as-number**

**Example:**

```
Router(config-bgp-nbr)# remote-as 1
```

Creates a neighbor and assigns a remote autonomous system (AS) number to it.

- Range for 2-byte autonomous system numbers (ASNs) is 1 to 65535.
- Range for 4-byte autonomous system numbers (ASNs) in asplain format is 1 to 4294967295.
- Range for 4-byte autonomous system numbers (ASNs) in asdot format is 1.0 to 65535.65535.

**Step 12**    **use neighbor-group group-name**

**Example:**

```
Router(config-bgp-nbr)# use neighbor-group n1
```

Specifies that the BGP neighbor inherit configuration from the specified neighbor group.

**Step 13**    **tcp mss inheritance-disable**

**Example:**

```
Router(config-bgp-nbr)# tcp mss inheritance-disable
```

Disables TCP MSS for the neighbor.

**Step 14**    **address-family ipv4 unicast**

**Example:**

```
Router(config-bgp-nbr)# address-family ipv4 unicast
```

```
Router(config-bgp-nbr-af)#
```

Specifies the IPv4 address family unicast and enters address family configuration mode.

**Step 15**    Use the **commit** or **end** command.

**commit** —Saves the configuration changes and remains within the configuration session.

**end** —Prompts user to take one of these actions:

- **Yes** — Saves configuration changes and exits the configuration session.
- **No** —Exits the configuration session without committing the configuration changes.
- **Cancel** —Remains in the configuration session, without committing the configuration changes.

## Configuring Discard Extra Paths

Perform this task to configure BGP maximum-prefix discard extra paths.

### Procedure

	Command or Action	Purpose
<b>Step 1</b>	<b>configure</b> <b>Example:</b> Router# configure	Enters Global configuration mode.
<b>Step 2</b>	<b>router bgp as-number</b> <b>Example:</b> Router(config)# router bgp 10	Specifies the autonomous system number and enters the BGP configuration mode, allowing you to configure the BGP routing process.
<b>Step 3</b>	<b>neighbor ip-address</b> <b>Example:</b> Router(config-bgp)# neighbor 10.0.0.1	Places the router in neighbor configuration mode for BGP routing and configures the neighbor IP address as a BGP peer.
<b>Step 4</b>	<b>address-family { ipv4   ipv6 } unicast</b> <b>Example:</b> Router(config-bgp-nbr)# address-family ipv4 unicast	Specifies either the IPv4 or IPv6 address family and enters address family configuration submenu.
<b>Step 5</b>	<b>maximum-prefix maximum discard-extra-paths</b> <b>Example:</b> Router(config-bgp-nbr-af)# maximum-prefix 1000 discard-extra-paths	Configures a limit to the number of prefixes allowed. Configures discard extra paths to discard extra paths when the maximum prefix limit is exceeded.
<b>Step 6</b>	Use the <b>commit</b> or <b>end</b> command.	<b>commit</b> —Saves the configuration changes and remains within the configuration session. <b>end</b> —Prompts user to take one of these actions: <ul style="list-style-type: none"> <li>• <b>Yes</b> — Saves configuration changes and exits the configuration session.</li> <li>• <b>No</b> —Exits the configuration session without committing the configuration changes.</li> </ul>

	Command or Action	Purpose
		<ul style="list-style-type: none"> <li>• <b>Cancel</b> —Remains in the configuration session, without committing the configuration changes.</li> </ul>

## Configuring Per Neighbor TCP MSS

Perform this task to configure TCP MSS under neighbor group, which is inherited by a neighbor.

### Step 1 **configure**

**Example:**

```
Router# configure
Enters .
```

### Step 2 **router bgp *as-number***

**Example:**

```
Router(config)# router bgp 10
```

Specifies the autonomous system number and enters the BGP configuration mode, allowing you to configure the BGP routing process.

### Step 3 **address-family *ipv4 unicast***

**Example:**

```
Router(config-bgp)# address-family ipv4 unicast
```

Specifies the IPv4 address family unicast and enters address family configuration mode.

### Step 4 **exit**

**Example:**

```
Router(config-bgp-af)# exit
```

Exits router address family configuration mode, and returns to BGP configuration mode.

### Step 5 **neighbor-group *name***

**Example:**

```
Router(config-bgp)# neighbor-group n1
Enters neighbor group configuration mode.
```

### Step 6 **tcp mss *segment-size***

**Example:**

```
Router(config-bgp-nbrgrp)# tcp mss 500
```

Configures TCP maximum segment size. The range is from 68 to 10000.

### Step 7 **address-family *ipv4 unicast***

**Example:**

```
Router(config-bgp-nbrgrp)# address-family ipv4 unicast
```

Specifies the IPv4 address family unicast and enters address family configuration mode.

**Step 8** **exit****Example:**

```
Router(config-bgp-nbrgrp-af)# exit
```

Exits router address family configuration mode.

**Step 9** **exit****Example:**

```
Router(config-bgp-nbrgrp)# exit
```

Exits the neighbor group configuration mode.

**Step 10** **neighbor** *ip-address***Example:**

```
Router(config-bgp)# neighbor 10.0.0.2
```

Places the router in neighbor configuration mode for BGP routing and configures the neighbor IP address as a BGP peer.

**Step 11** **remote-as** *as-number***Example:**

```
Router(config-bgp-nbr)# remote-as 1
```

Creates a neighbor and assigns a remote autonomous system (AS) number to it.

- Range for 2-byte autonomous system numbers (ASNs) is 1 to 65535.
- Range for 4-byte autonomous system numbers (ASNs) in asplain format is 1 to 4294967295.
- Range for 4-byte autonomous system numbers (ASNs) in asdot format is 1.0 to 65535.65535.

**Step 12** **use neighbor-group** *group-name***Example:**

```
Router(config-bgp-nbr)# use neighbor-group n1
```

Specifies that the BGP neighbor inherit configuration from the specified neighbor group.

**Step 13** **address-family** **ipv4 unicast****Example:**

```
Router(config-bgp-nbr)# address-family ipv4 unicast
```

```
Router(config-bgp-nbr-af)#
```

Specifies the IPv4 address family unicast and enters address family configuration mode.

**Step 14** Use the **commit** or **end** command.

**commit** —Saves the configuration changes and remains within the configuration session.

**end** —Prompts user to take one of these actions:

- **Yes** — Saves configuration changes and exits the configuration session.
- **No** — Exits the configuration session without committing the configuration changes.
- **Cancel** — Remains in the configuration session, without committing the configuration changes.

---

## Disabling Per Neighbor TCP MSS

Perform this task to disable TCP MSS for a particular neighbor under neighbor group.

---

**Step 1**     **configure**

**Example:**

```
Router# configure
```

**Step 2**     **router bgp *as-number***

**Example:**

```
Router(config)# router bgp 10
```

Specifies the autonomous system number and enters the BGP configuration mode, allowing you to configure the BGP routing process.

**Step 3**     **address-family ipv4 unicast**

**Example:**

```
Router(config-bgp)# address-family ipv4 unicast
```

Specifies the IPv4 address family unicast and enters address family configuration mode.

**Step 4**     **exit**

**Example:**

```
Router(config-bgp-af)# exit
```

Exits router address family configuration mode, and returns to BGP configuration mode.

**Step 5**     **neighbor-group *name***

**Example:**

```
Router(config-bgp)# neighbor-group n1
```

Enters neighbor group configuration mode.

**Step 6**     **tcp mss *segment-size***

**Example:**

```
Router(config-bgp-nbrgrp)# tcp mss 500
```

Configures TCP maximum segment size. The range is from 68 to 10000.

**Step 7**     **address-family ipv4 unicast**

**Example:**

```
Router(config-bgp-nbrgrp)# address-family ipv4 unicast
```

Specifies the IPv4 address family unicast and enters address family configuration mode.

**Step 8**     **exit****Example:**

```
Router(config-bgp-nbrgrp-af)# exit
```

Exits router address family configuration mode.

**Step 9**     **exit****Example:**

```
Router(config-bgp-nbrgrp)# exit
```

Exits the neighbor group configuration mode.

**Step 10**    **neighbor** *ip-address***Example:**

```
Router(config-bgp)# neighbor 10.0.0.2
```

Places the router in neighbor configuration mode for BGP routing and configures the neighbor IP address as a BGP peer.

**Step 11**    **remote-as** *as-number***Example:**

```
Router(config-bgp-nbr)# remote-as 1
```

Creates a neighbor and assigns a remote autonomous system (AS) number to it.

- Range for 2-byte autonomous system numbers (ASNs) is 1 to 65535.
- Range for 4-byte autonomous system numbers (ASNs) in asplain format is 1 to 4294967295.
- Range for 4-byte autonomous system numbers (ASNs) in asdot format is 1.0 to 65535.65535.

**Step 12**    **use neighbor-group** *group-name***Example:**

```
Router(config-bgp-nbr)# use neighbor-group n1
```

Specifies that the BGP neighbor inherit configuration from the specified neighbor group.

**Step 13**    **tcp mss inheritance-disable****Example:**

```
Router(config-bgp-nbr)# tcp mss inheritance-disable
```

Disables TCP MSS for the neighbor.

**Step 14**    **address-family** *ipv4 unicast***Example:**

```
Router(config-bgp-nbr)# address-family ipv4 unicast
Router(config-bgp-nbr-af)#
```

Specifies the IPv4 address family unicast and enters address family configuration mode.

**Step 15** Use the **commit** or **end** command.

**commit** —Saves the configuration changes and remains within the configuration session.

**end** —Prompts user to take one of these actions:

- **Yes** — Saves configuration changes and exits the configuration session.
- **No** —Exits the configuration session without committing the configuration changes.
- **Cancel** —Remains in the configuration session, without committing the configuration changes.

---

## Configure BGP Route Filtering by Route Policy

Perform this task to configure BGP routing filtering by route policy.

---

**Step 1** **configure**

**Step 2** **route-policy** *name*

**Example:**

```
Router(config)# route-policy drop-as-1234
Router(config-rpl)# if as-path passes-through '1234' then
Router(config-rpl)# apply check-communities
Router(config-rpl)# else
Router(config-rpl)# pass
Router(config-rpl)# endif
```

(Optional) Creates a route policy and enters route policy configuration mode, where you can define the route policy.

**Step 3** **end-policy**

**Example:**

```
Router(config-rpl)# end-policy
```

(Optional) Ends the definition of a route policy and exits route policy configuration mode.

**Step 4** **router bgp** *as-number*

**Example:**

```
Router(config)# router bgp 120
```

Specifies the autonomous system number and enters the BGP configuration mode, allowing you to configure the BGP routing process.

**Step 5** **neighbor** *ip-address*

**Example:**

```
Router(config-bgp)# neighbor 172.168.40.24
```

Places the router in neighbor configuration mode for BGP routing and configures the neighbor IP address as a BGP peer.

**Step 6** **address-family { ipv4 | ipv6 } unicast****Example:**

```
Router(config-bgp-nbr)# address-family ipv4 unicast
```

Specifies either an IPv4 or IPv6 address family unicast and enters address family configuration submode.

To see a list of all the possible keywords and arguments for this command, use the CLI help (?).

**Step 7** **route-policy route-policy-name { in | out }****Example:**

```
Router(config-bgp-nbr-af)# route-policy drop-as-1234 in
```

Applies the specified policy to inbound routes.

**Step 8** **commit**

---

## Configure BGP Attribute Filtering

### SUMMARY STEPS

1. **configure**
2. **router bgp** *as-number*
3. **attribute-filter group** *attribute-filter group name*
4. **attribute** *attribute code* { **discard** | **treat-as-withdraw** }

### DETAILED STEPS

---

**Step 1** **configure****Example:**

```
RP/0/# configure
```

Enters mode.

**Step 2** **router bgp** *as-number***Example:**

```
Router(config)# router bgp 100
```

Specifies the autonomous system number and enters the BGP configuration mode, allowing you to configure the BGP routing process.



**Step 3** `attribute-filter group` *attribute-filter group name*

**Example:**

```
Router(config-bgp)# attribute-filter group ag_discard_med
```

Specifies the attribute-filter group name and enters the attribute-filter group configuration mode, allowing you to configure a specific attribute filter group for a BGP neighbor.

**Step 4** `attribute` *attribute code* { **discard** | **treat-as-withdraw** }

**Example:**

```
Router(config-bgp-attrfg)# attribute 24 discard
```

Specifies a single or a range of attribute codes and an associated action. The allowed actions are:

- **Treat-as-withdraw**— Considers the update message for withdrawal. The associated IPv4-unicast or MP\_REACH NLRIs, if present, are withdrawn from the neighbor's Adj-RIB-In.
- **Discard Attribute**— Discards this attribute. The matching attributes alone are discarded and the rest of the Update message is processed normally.

---

## Configure BGP Next-Hop Trigger Delay

Perform this task to configure BGP next-hop trigger delay. The Routing Information Base (RIB) classifies the dampening notifications based on the severity of the changes. Event notifications are classified as critical and noncritical. This task allows you to specify the minimum batching interval for the critical and noncritical events.

### SUMMARY STEPS

1. **configure**
2. **router bgp** *as-number*
3. **address-family** { **ipv4** | **ipv6** } **unicast**
4. **nexthop trigger-delay** { **critical** *delay* | **non-critical** *delay* }
5. Use the **commit** or **end** command.

### DETAILED STEPS

---

**Step 1** **configure**

**Example:**

```
RP/0/# configure
```

Enters mode.

**Step 2** **router bgp** *as-number*

**Example:**

```
Router(config)# router bgp 120
```

Specifies the autonomous system number and enters the BGP configuration mode, allowing you to configure the BGP routing process.

**Step 3** `address-family { ipv4 | ipv6 } unicast`

**Example:**

```
Router(config-bgp)# address-family ipv4 unicast
```

Specifies either an IPv4 or IPv6 address family unicast and enters address family configuration submode.

To see a list of all the possible keywords and arguments for this command, use the CLI help (?).

**Step 4** `nexthop trigger-delay { critical delay | non-critical delay }`

**Example:**

```
Router(config-bgp-af)# nexthop trigger-delay critical 15000
```

Sets the critical next-hop trigger delay.

This list provides the default **critical** and **non-critical** delay values for the specified address families.

- **critical** : 3000 msec for all address families, except VPNv4 and VPNv6 address families.
- **critical**: 50 msec for VPNv4 and VPNv6 address families.
- **non-critical**: 10000 msec for all address families.

**Step 5** Use the **commit** or **end** command.

**commit** —Saves the configuration changes and remains within the configuration session.

**end** —Prompts user to take one of these actions:

- **Yes** — Saves configuration changes and exits the configuration session.
- **No** —Exits the configuration session without committing the configuration changes.
- **Cancel** —Remains in the configuration session, without committing the configuration changes.

## Disable Next-Hop Processing on BGP Updates

Perform this task to disable next-hop calculation for a neighbor and insert your own address in the next-hop field of BGP updates. Disabling the calculation of the best next hop to use when advertising a route causes all routes to be advertised with the network device as the next hop.



**Note** Next-hop processing can be disabled for address family group, neighbor group, or neighbor address family.

**Step 1** `configure`

**Example:**

```
RP/0/# configure
```

Enters mode.

**Step 2** **router bgp** *as-number*

**Example:**

```
Router(config)# router bgp 120
```

Specifies the autonomous system number and enters the BGP configuration mode, allowing you to configure the BGP routing process.

**Step 3** **neighbor** *ip-address*

**Example:**

```
Router(config-bgp)# neighbor 172.168.40.24
```

Places the router in neighbor configuration mode for BGP routing and configures the neighbor IP address as a BGP peer.

**Step 4** **remote-as** *as-number*

**Example:**

```
Router(config-bgp-nbr)# remote-as 206
```

Creates a neighbor and assigns a remote autonomous system number to it.

**Step 5** **address-family** { **ipv4** | **ipv6** } **unicast**

**Example:**

```
Router(config-bgp-nbr)# address-family ipv4 unicast
```

Specifies either an IPv4 or IPv6 address family unicast and enters address family configuration submode.

To see a list of all the possible keywords and arguments for this command, use the CLI help (?).

**Step 6** **next-hop-self**

**Example:**

```
Router(config-bgp-nbr-af)# next-hop-self
```

Sets the next-hop attribute for all routes advertised to the specified neighbor to the address of the local router. Disabling the calculation of the best next hop to use when advertising a route causes all routes to be advertised with the local network device as the next hop.

**Step 7** Use the **commit** or **end** command.

**commit** —Saves the configuration changes and remains within the configuration session.

**end** —Prompts user to take one of these actions:

- **Yes** — Saves configuration changes and exits the configuration session.
- **No** —Exits the configuration session without committing the configuration changes.
- **Cancel** —Remains in the configuration session, without committing the configuration changes.

# Configure BGP Community and Extended-Community Advertisements

Perform this task to specify that community/extended-community attributes should be sent to an eBGP neighbor. These attributes are not sent to an eBGP neighbor by default. By contrast, they are always sent to iBGP neighbors. This section provides examples on how to enable sending community attributes. The **send-community-ebgp** keyword can be replaced by the **send-extended-community-ebgp** keyword to enable sending extended-communities.

If the **send-community-ebgp** command is configured for a neighbor group or address family group, all neighbors using the group inherit the configuration. Configuring the command specifically for a neighbor overrides inherited values.



**Note** BGP community and extended-community filtering cannot be configured for iBGP neighbors. Communities and extended-communities are always sent to iBGP neighbors under VPNv4, MDT, IPv4, and IPv6 address families.

## Step 1 **configure**

### Example:

```
RP/0/# configure
Enters mode.
```

## Step 2 **router bgp** *as-number*

### Example:

```
Router(config)# router bgp 120
```

Specifies the autonomous system number and enters the BGP configuration mode, allowing you to configure the BGP routing process.

## Step 3 **neighbor** *ip-address*

### Example:

```
Router(config-bgp)# neighbor 172.168.40.24
```

Places the router in neighbor configuration mode for BGP routing and configures the neighbor IP address as a BGP peer.

## Step 4 **remote-as** *as-number*

### Example:

```
Router(config-bgp-nbr)# remote-as 2002
```

Creates a neighbor and assigns a remote autonomous system number to it.

## Step 5 **address-family** {**ipv4** {**labeled-unicast** | **unicast** | **mdt** | | **mvpn** | **rt-filter** | **tunnel**} | **ipv6** {**labeled-unicast** | **mvpn** | **unicast**}}

### Example:

```
Router(config-bgp-nbr)# address-family ipv6 unicast
```

Enters neighbor address family configuration mode for the specified address family. Use either **ipv4** or **ipv6** address family keyword with one of the specified address family sub mode identifiers.

IPv6 address family mode supports these sub modes:

- **labeled-unicast**
- **mvpn**
- **unicast**

IPv4 address family mode supports these sub modes:

- **labeled-unicast**
- **mdt**
- **mvpn**
- **rt-filter**
- **tunnel**
- **unicast**

**Step 6** Use one of these commands:

- **send-community-ebgp**
- **send-extended-community-ebgp**

**Example:**

```
Router(config-bgp-nbr-af)# send-community-ebgp
```

or

```
Router(config-bgp-nbr-af)# send-extended-community-ebgp
```

Specifies that the router send community attributes or extended community attributes (which are disabled by default for eBGP neighbors) to a specified eBGP neighbor.

**Step 7** Use the **commit** or **end** command.

**commit** —Saves the configuration changes and remains within the configuration session.

**end** —Prompts user to take one of these actions:

- **Yes** — Saves configuration changes and exits the configuration session.
  - **No** —Exits the configuration session without committing the configuration changes.
  - **Cancel** —Remains in the configuration session, without committing the configuration changes.
-

# Configure BGP Cost Community

BGP receives multiple paths to the same destination and it uses the best-path algorithm to decide which is the best path to install in RIB. To enable users to determine an exit point after partial comparison, the cost community is defined to tie-break equal paths during the best-path selection process. Perform this task to configure the BGP cost community.

---

**Step 1** **configure****Example:**

```
RP/0/# configure
```

Enters mode.

**Step 2** **route-policy** *name***Example:**

```
Router(config)# route-policy costA
```

Enters route policy configuration mode and specifies the name of the route policy to be configured.

**Step 3** **set extcommunity cost** { *cost-extcommunity-set-name* | *cost-inline-extcommunity-set* } [ **additive** ]**Example:**

```
Router(config)# set extcommunity cost cost_A
```

Specifies the BGP extended community attribute for cost.

**Step 4** **end-policy****Example:**

```
Router(config)# end-policy
```

Ends the definition of a route policy and exits route policy configuration mode.

**Step 5** **router bgp** *as-number***Example:**

```
Router(config)# router bgp 120
```

Enters BGP configuration mode allowing you to configure the BGP routing process.

**Step 6** Do one of the following:

- **default-information originate**
- **aggregate-address** *address/mask-length* [ **as-set** ] [ **as-confed-set** ] [ **summary-only** ] [ **route-policy** *route-policy-name* ]

Applies the cost community to the attach point (route policy).

**Step 7** Do one of the following:

- **neighbor** *ip-address* **remote-as** *as-number*
- **route-policy** *route-policy-name* { **in** | **out** }

**Step 8** Use the **commit** or **end** command.

**commit** —Saves the configuration changes and remains within the configuration session.

**end** —Prompts user to take one of these actions:

- **Yes** — Saves configuration changes and exits the configuration session.
- **No** —Exits the configuration session without committing the configuration changes.
- **Cancel** —Remains in the configuration session, without committing the configuration changes.

**Step 9** **show bgp** *ip-address*

**Example:**

```
Router# show bgp 172.168.40.24
```

Displays the cost community in the following format:

Cost: *POI* : *cost-community-ID* : *cost-number*

## Configure Software to Store Updates from Neighbor

Perform this task to configure the software to store updates received from a neighbor.

The **soft-reconfiguration inbound** command causes a route refresh request to be sent to the neighbor if the neighbor is route refresh capable. If the neighbor is not route refresh capable, the neighbor must be reset to relearn received routes using the **clear bgp soft** command.



**Note** Storing updates from a neighbor works only if either the neighbor is route refresh capable or the **soft-reconfiguration inbound** command is configured. Even if the neighbor is route refresh capable and the **soft-reconfiguration inbound** command is configured, the original routes are not stored unless the **always** option is used with the command. The original routes can be easily retrieved with a route refresh request. Route refresh sends a request to the peer to resend its routing information. The **soft-reconfiguration inbound** command stores all paths received from the peer in an unmodified form and refers to these stored paths during the clear. Soft reconfiguration is memory intensive.

### SUMMARY STEPS

1. **configure**
2. **router bgp** *as-number*
3. **neighbor** *ip-address*
4. **address-family** { **ipv4** | **ipv6** } **unicast**
5. **soft-reconfiguration inbound** [ **always** ]
6. Use the **commit** or **end** command.

## DETAILED STEPS

**Step 1** **configure****Example:**

```
RP/0/# configure
```

Enters mode.

**Step 2** **router bgp** *as-number***Example:**

```
Router(config)# router bgp 120
```

Specifies the autonomous system number and enters the BGP configuration mode, allowing you to configure the BGP routing process.

**Step 3** **neighbor** *ip-address***Example:**

```
Router(config-bgp)# neighbor 172.168.40.24
```

Places the router in neighbor configuration mode for BGP routing and configures the neighbor IP address as a BGP peer.

**Step 4** **address-family** { **ipv4** | **ipv6** } **unicast****Example:**

```
Router(config-bgp-nbr)# address-family ipv4 unicast
```

Specifies either an IPv4 or IPv6 address family unicast and enters address family configuration submode.

To see a list of all the possible keywords and arguments for this command, use the CLI help (?).

**Step 5** **soft-reconfiguration inbound** [ **always**]**Example:**

```
Router(config-bgp-nbr-af)# soft-reconfiguration inbound always
```

Configures the software to store updates received from a specified neighbor. Soft reconfiguration inbound causes the software to store the original unmodified route in addition to a route that is modified or filtered. This allows a “soft clear” to be performed after the inbound policy is changed.

Soft reconfiguration enables the software to store the incoming updates before apply policy if route refresh is not supported by the peer (otherwise a copy of the update is not stored). The **always** keyword forces the software to store a copy even when route refresh is supported by the peer.

**Step 6** Use the **commit** or **end** command.

**commit** —Saves the configuration changes and remains within the configuration session.

**end** —Prompts user to take one of these actions:

- **Yes** — Saves configuration changes and exits the configuration session.
- **No** —Exits the configuration session without committing the configuration changes.



- **Cancel**—Remains in the configuration session, without committing the configuration changes.

---

## BGP Persistence

BGP persistence enables the local router to retain routes that it has learnt from the configured neighbor even after the neighbor session is down. BGP persistence is also referred as Long Lived Graceful Restart (LLGR). LLGR takes effect after graceful restart (GR) ends or immediately if GR is not enabled. LLGR ends either when the LLGR stale timer expires or when the neighbor sends the end-of-RIB marker after it has revised its routes. When LLGR for a neighbor ends, all routes from that neighbor that are still stale will be deleted. The LLGR capability is signaled to a neighbor in the BGP OPEN message if it has been configured for that neighbor. LLGR differs from graceful restart in the following ways.

- It can be in effect for a much longer time than GR
- LLGR stale routes are least preferred during route selection (bestpath computation).
- An LLGR stale route will be advertised with the LLGR\_STALE community attached if it is selected as best path. It will not be advertised at all to routers that are not LLGR capable.
- LLGR stale routes will not be deleted when the forwarding path to the neighbor is detected to be down.
- An LLGR stale route will not be deleted if the BGP session to the neighbor goes down multiple times even if that neighbor does not re-advertise the route.
- Any route that has the NO\_LLGR community will not be retained.

BGP will not pass the updates containing communities 65535:6, 65535:7 to its neighbors until the neighbors negotiate BGP persistence capabilities. The communities 65535:6 and 65535:7 are reserved for LLGR\_STALE and NO\_LLGR respectively, BGP behavior maybe unpredictable if you have configured these communities prior to release 5.2.2. We recommend not to configure the communities 65535:6 and 65535:7.

The BGP persistence feature is supported only on the following AFIs:

- VPNv4 and VPNv6
- RT constraint
- Flow spec (IPv4, IPv6, VPNv4 and VPNv6)
- IPv4 and IPv6 address family

## BGP Persistence Configuration: Example

This example sets long lived graceful restart (LLGR) stale-time of 16777215 on BGP neighbor 10.3.3.3.

```
router bgp 100
 neighbor 10.3.3.3
  remote-as 30813
  update-source Loopback0
  graceful-restart stalepath-time 150
  address-family vpnv4 unicast
  long-lived-graceful-restart capable
```

```
    long-lived-graceful-restart stale-time send 16777215 accept 16777215
  !
  address-family vpnv6 unicast
    long-lived-graceful-restart capable
    long-lived-graceful-restart stale-time send 16777215 accept 16777215
```

# Flexible BGP Persistence

*Table 12: Feature History Table*

<b>Feature Name</b>	<b>Release Name</b>	<b>Description</b>
Flexible BGP Persistence	Release 24.3.1	

Feature Name	Release Name	Description
		<p>Introduced in this release on: Fixed Systems (8200, 8700); Centralized Systems (8600); Modular Systems (8800 [LC ASIC: Q100, Q200, P100])</p> <p>Now you can ensure continuous connectivity by allowing non-Long Lived Graceful Restart (LLGR) eBGP neighbors to use LLGR stale routes, allowing for LLGR capability to be enabled and advertised without having to explicitly configure a timeout value, and gain greater flexibility in route management by advertising stale routes to non-LLGR peers through the NO_EXPORT community. This is an enhancement to the existing BGP Persistence feature.</p> <p>The feature introduces these changes:</p> <p><b>CLI:</b></p> <ul style="list-style-type: none"> <li>• The <b>default</b>, <b>any</b>, and <b>advertise-internal-only</b> keywords are added to the <a href="#">long-lived-graceful-restart</a> command.</li> <li>• The fields <b>Long-lived Graceful Restart Stale Time Send Default</b>, <b>Default advertised long-lived stale time</b>, and <b>Long-lived Graceful Restart Stale Time Accept Any</b> are added to the show output of the <a href="#">show bgp</a> command.</li> </ul> <p><b>YANG Data Model:</b></p> <ul style="list-style-type: none"> <li>• <a href="#">Cisco-IOS-XR-ipv4-bgp-cfg</a> (see <a href="#">GitHub</a>, <a href="#">YANG Data Models Navigator</a>)</li> </ul>

## Flexible BGP Persistence and its Benefits

The Flexible BGP Persistence feature provides you the flexibility to enable LLGR without manual timeout configuration, advertise LLGR stale routes to non-LLGR eBGP neighbors seamlessly, and ensures controlled route distribution and policy enforcement by attaching NO\_EXPORT community and setting local preference to 0.

- **Simplified configuration:** You can configure the router to enable and advertise the LLGR capability without explicitly setting a timeout value, and to accept the LLGR stale time provided by the peer without imposing its own threshold, by using the **long-lived-graceful-restart send default accept any** command.
- The **send default** keyword pair provides the flexibility from not having to specify a timeout value.

The **accept any** keyword pair allows the router to accept the LLGR stale time provided by the peer without imposing its own threshold for acceptance. This flexibility ensures compatibility with a wider range of peer configurations and simplifies the management of LLGR settings.

- **Enhanced network resilience:** This feature allows LLGR stale routes to be advertised to non-LLGR capable eBGP neighbors, enhancing network resilience. This capability ensures that even non-LLGR capable neighbors can benefit from the stability provided by LLGR, thereby contributing to overall network robustness.
- **Enhanced network stability:** This feature allows the attachment of the NO\_EXPORT community and setting the local preference to 0 when advertising an LLGR route to an internal neighbor that has not negotiated the capability. The LLGR\_STALE community is always sent along with NO\_EXPORT community. The feature allows explicit configuration to enable this requirement through the **long-lived-graceful-restart capable advertise-internal-only** command.

This approach prevents the stale route from being propagated beyond the local Autonomous System (AS) and ensures that it is not preferred over other routes. This helps maintain network stability and prevents potential routing issues by ensuring that only capable and properly negotiated routes are used for forwarding traffic.

## Configure Flexible BGP Persistence

### Configure LLGR Advertisement and Activation with Default and Peer-Specified Stale Time

**Step 1** Configure LLGR advertisement and activation with default and peer-specified stale time.

**Example:**

```
Router(config)# router bgp 100
Router(config-bgp)# neighbor 10.1.1.1
Router(config-bgp-nbr)# address-family ipv4 unicast
Router(config-bgp-nbr-af)# long-lived-graceful-restart stale-time send default accept any
```

Configure the local router to advertise the LLGR capability to the neighbor and activate LLGR for prefixes received from the neighbor, specify that the router sends the default value, which is 172800 seconds, for the LLGR time, and ensure that the router accepts the LLGR stale time provided by the peer without imposing its own acceptance threshold.

**Step 2** Verify that the router is configured to send a default LLGR stale time to its BGP neighbors, that the default stale time being advertised is 172800 seconds, and that the router accepts any LLGR stale time value provided by the peer without imposing its own threshold.

**Example:**

```
Router(config)# show bgp neighbor 192.0.2.254
...
AF-dependent capabilities:
  Long-lived Graceful Restart Capability advertised
    Advertised Long-lived Stale time 172800 seconds
  Long-lived Graceful Restart Stale Time Send Default is ON
  Default advertised long-lived stale time is 172800 seconds
  Long-lived Graceful Restart Stale Time Accept Any is ON
  Maximum acceptable long-lived stale time from this neighbor is 16777215
  Long-lived Graceful Restart Capability received
    Received long-lived stale time is 172800 seconds
    Neighbor preserved the forwarding state during latest restart
...
```

Here is an explanation of the highlighted fields:

- **Long-lived Graceful Restart Stale Time Send Default is ON:** This field indicates that the router is configured to send a default value for the LLGR stale time to its BGP neighbors. The default stale time is used when the router advertises its LLGR capability.
- **Default advertised long-lived stale time is 172800 seconds:** This field specifies the default LLGR stale time value that the router advertises to its BGP neighbors. In this case, Cisco sets the the default stale time to 172800 seconds, which is equivalent to 2 days, in the BGP configuration parameters.
- **Long-lived Graceful Restart Stale Time Accept Any is ON:** This field indicates that the router is configured to accept any LLGR stale time value provided by its BGP neighbors. The router does not impose its own threshold for the stale time and accepts the value sent by the peer.

---

## Enable the LLGR Capability and Advertise It Only to iBGP Peers

---

**Step 1** Enable the LLGR capability and advertise it only to iBGP peers.

**Example:**

```
Router(config)# router bgp 100
Router(config-bgp)# neighbor 10.1.1.1
Router(config-bgp-nbr)# address-family ipv4 unicast
Router(config-bgp-nbr-af)# long-lived-graceful-restart capable advertise-internal-only
```

Configure the router to enable the LLGR capability and advertise it exclusively to iBGP peers. Set the local preference of the router to 0 to ensure it is not preferred for outbound traffic within the AS and is utilized only when no other routes are available. Set the community attribute to llgr-stale to retain the route temporarily during a graceful restart event. Additionally, set the community attribute to no-export to limit the propagation of the route within the local AS.

**Step 2** Verify that the route is not preferred for outbound traffic within the AS, and that it will not be advertised to external BGP peers, thereby limiting its propagation to within the local AS.

**Example:**

```
Router# show bgp 10.1.1.1

Path #32: Received by speaker 0
...
192.0.2.254 (metric 30) from 10.1.1.1 (192.0.2.254)
  Origin IGP, localpref 0, valid, internal, add-path
  Received Path ID 40, Local Path ID 9, version 14321
```

```
Community: llgr-stale no-export
Originator: 192.0.2.254, Cluster list: 10.1.1.1
```

---

## BGP Graceful Maintenance

When a BGP link or router is taken down, other routers in the network find alternative paths for the traffic that was flowing through the failed router or link, if such alternative paths exist. The time required before all routers involved can reach a consensus about an alternate path is called convergence time. During convergence time, traffic that is directed to the router or link that is down is dropped. The BGP Graceful Maintenance feature allows the network to perform convergence before the router or link is taken out of service. The router or link remains in service while the network reroutes traffic to alternative paths. Any traffic that is yet on its way to the affected router or link is still delivered as before. After all traffic has been rerouted, the router or link can safely be taken out of service.

The Graceful Maintenance feature is helpful when alternate paths exist and these alternate paths are not known to routers at the time that the primary paths are withdrawn. The feature provides these alternate paths before the primary paths are withdrawn. The feature is most helpful in networks where convergence time is long. Several factors, such as large routing tables and presence of route reflectors, can result in longer convergence time.

When a BGP router or link is brought into service, the possibility of traffic loss during convergence also exists, although it is less than when a router or link is taken out of service. The BGP Graceful Maintenance feature can also be used in this scenario.

## Restrictions for BGP Graceful Maintenance

The following restrictions apply for BGP Graceful Maintenance:

- If the affected router is configured to send the GSHUT community attribute, then other routers in the network that receive it must be configured to interpret it. You must match the community with a routing policy and set a lower preference.
- The LOCAL\_PREF attribute is not sent to another AS. Therefore, the LOCAL\_PREF option cannot be used on an eBGP link.



---

**Note** This restriction does not apply to eBGP links between member-ASs of an AS confederation.

---

- Alternative routes must exist in the network, otherwise advertising a lower preference has no effect. For example, there is no advantage in configuring Graceful Maintenance for a singly-homed customer router which does not have alternate routes.
- If time consuming policies exist, either at the output of the sending router or at the input of the receiving router, the Graceful Maintenance operation can take a long time.
- Configuring an eBGP ASBR neighbor results in advertising an implicit null label for directly connected routes via BGP. If a user shuts down an eBGP neighbor, the label is not reprogrammed as the system

withdraws rewrites on any neighbor state changes. Implicit null label feature support helps avoid churn in terms of adding or removing rewrites for neighbor flaps.

## Graceful Maintenance Operation

When Graceful Maintenance is activated, the affected routes are advertised again with a reduced preference. This causes neighboring routers to choose alternative routes. You can use any of the following methods to signal reduced route preference:

- **Add GSHUT community:** Use this method to allow remote routers the freedom to set a preference. Receiving routers must match this community in a policy and set their own preference.
- **Reduce LOCAL\_PREF value:** This works for internal BGP neighbors. Use this method if remote routers do not match the GSHUT community.
- **Prepend AS Path:** This works for both internal and external BGP neighbors. Use this method if remote routers do not match the GSHUT community.

When Graceful Maintenance is activated on a BGP connection, the following two operations happen:

1. All routes received from the connection are re-advertised to other neighbors with a lower preference. Note, this happens to only those routes that have actually been advertised to other neighbors. It is possible that a received route was not selected as the best path and therefore not advertised. In that case, it will not be re-advertised.
2. All routes that were advertised to the connection is re-advertised with a lower preference.

In order for the first operation to happen, all routes received from the connection are tagged with an internal attribute called graceful-shut. This attribute is stored internal to only the router; it is not advertised by BGP. This attribute can be seen when the route is displayed with the **show bgp** command. It is different from the GSHUT community. The GSHUT community is advertised by BGP and can be seen in the community list when the route is displayed with the **show bgp** command.

All routes that have the graceful-shut attribute are given the lowest preference during route-selection. Any new route updates that are sent or received on a BGP session under Graceful Maintenance are also treated as described above.

## Inter Autonomous System

Advertising a lower preference to another AS in the public Internet may cause unnecessary routing advertisements in distant networks, which may not be desirable. An additional configuration under the neighbor address family, **send-community-gshut-ebgp**, is necessary for the router to originate the GSHUT community to the eBGP neighbor.



---

**Note** This does not affect the GSHUT community on a route that already had this community when it was received; it only affects the GSHUT community when this router adds it.

---



## When to Shut Down After Graceful Maintenance

The router or link can be shut down after the network has converged as a result of a graceful-maintenance activation. Convergence can take from less than a second to more than an hour. Unfortunately, a single router cannot know when a whole network has converged. After a graceful-maintenance activation, it can take a few seconds to start sending updates. Then, the “InQ” and “OutQ” of neighbors in the **show bgp <vrf> <afi> <safi> summary** command's output indicates the level of BGP messaging. Both InQ and OutQ should be 0 after convergence. Neighbors should stop sending traffic. However, they won't stop sending traffic if they do not have alternate paths; and in that case traffic loss cannot be prevented.

## Activate Graceful Maintenance under BGP Router (All Neighbors)

Activating Graceful Maintenance under a BGP router results in **activate** being configured under **graceful-maintenance** for all neighbors. With just this one configuration, you get the same result if you were to go to every neighbor that has **graceful-maintenance** configured, and added **activate** under it. If you add the keyword **all-neighbors**, thus, **graceful-maintenance activate all-neighbors**, then the router acts as if you configured **graceful-maintenance activate** under every neighbor.



---

**Note** We suggest that you activate Graceful Maintenance under a BGP router instance only if it is acceptable to send the GSHUT community for all routes on every neighbor. Re-sending all routes to every neighbor can take significant amount of time on a large router. Sending GSHUT to a neighbor that does not have alternative routes is pointless. If a router has many of such neighbors then a significant amount of time can be saved by not activating Graceful Maintenance on them.

---

The BGP Graceful Maintenance feature allows you to enable Graceful Maintenance either on a single neighbor, on a group of neighbors across BGP sessions, or on all neighbors. Enabling Graceful Maintenance under a neighbor sub-mode, does two things:

1. All routes that are advertised to this neighbor that has the graceful-shut attribute are advertised to that neighbor with the GSHUT community.
2. Enters graceful-maintenance configuration mode to allow further configuration.

Using the **activate** keyword under graceful-maintenance, causes the following:

1. All routes that are received from this neighbor acquire the graceful-shut attribute.
2. All routes that are advertised to this neighbor are re-advertised to that neighbor with the GSHUT community.

### SUMMARY STEPS

1. **configure**
2. **router bgp** *as-number*
3. **graceful-maintenance activate** [ **all-neighbors** | **retain-routes** ]
4. Use the **commit** or **end** command.

## DETAILED STEPS

	Command or Action	Purpose
<b>Step 1</b>	<b>configure</b> <b>Example:</b> RP/0/# configure	Enters mode.
<b>Step 2</b>	<b>router bgp <i>as-number</i></b> <b>Example:</b> Router(config)# router bgp 120	Specifies the BGP AS number and enters the BGP configuration mode, allowing you to configure the BGP routing process.
<b>Step 3</b>	<b>graceful-maintenance activate [ <b>all-neighbors</b>   <b>retain-routes</b> ]</b> <b>Example:</b> Router(config-bgp)# graceful-maintenance activate all-neighbors	<p>Announces routes with the g-shut community and other attributes as configured under the neighbors. This causes neighbors to reject routes from this router and choose alternates. This allows the router to be gracefully brought in or out of service.</p> <p>If you use the <b>all-neighbors</b> keyword, Graceful Maintenance is activated even for those neighbors that do not have it activated. Choosing <b>retain-routes</b> causes RIB to retain BGP routes when the BGP process is stopped.</p> <p>Use the <b>retain-routes</b> option when only BGP must be brought down instead of the entire router, and when it is known that neighboring routers are kept in operation during the maintenance of the local BGP. If RIB has alternative routes provided by another protocol or a default route, then it is recommended that you do not to retain BGP routes after the BGP process stops.</p>
<b>Step 4</b>	Use the <b>commit</b> or <b>end</b> command.	<p><b>commit</b> —Saves the configuration changes and remains within the configuration session.</p> <p><b>end</b> —Prompts user to take one of these actions:</p> <ul style="list-style-type: none"> <li>• <b>Yes</b> — Saves configuration changes and exits the configuration session.</li> <li>• <b>No</b> —Exits the configuration session without committing the configuration changes.</li> <li>• <b>Cancel</b> —Remains in the configuration session, without committing the configuration changes.</li> </ul>

**What to do next**

After activating Graceful Maintenance, you must wait for all the routes to be sent and for the neighboring routers to redirect their traffic away from the router or link under maintenance. After the traffic is redirected, then it is safe to take the router or link out of service. While there is no definitive way to know when all the routes have been sent, you can use the **show bgp summary** command to check the OutQ of the neighbors. When OutQ reaches a value 0, there are no more updates to be sent.

## Activate Graceful Maintenance on a Single Neighbor

Use the following steps to activate Graceful Maintenance for a single neighbor:

### SUMMARY STEPS

1. **configure**
2. **router bgp** *as-number*
3. **neighbor** *ip-address*
4. **graceful-maintenance activate**
5. Use the **commit** or **end** command.

### DETAILED STEPS

	Command or Action	Purpose
Step 1	<b>configure</b> <b>Example:</b> RP/0/# configure	Enters mode.
Step 2	<b>router bgp</b> <i>as-number</i> <b>Example:</b> Router(config)# router bgp 120	Specifies the BGP AS number and enters the BGP configuration mode, allowing you to configure the BGP routing process.
Step 3	<b>neighbor</b> <i>ip-address</i> <b>Example:</b> Router(config-bgp)# neighbor 172.168.40.24	Places the router in neighbor configuration mode for BGP routing and configures the neighbor IP address as a BGP peer.
Step 4	<b>graceful-maintenance activate</b> <b>Example:</b> Router(config-bgp-nbr)# graceful-maintenance activate	Announces routes with Graceful Maintenance attributes.
Step 5	Use the <b>commit</b> or <b>end</b> command.	<b>commit</b> —Saves the configuration changes and remains within the configuration session. <b>end</b> —Prompts user to take one of these actions: <ul style="list-style-type: none"> <li>• <b>Yes</b> — Saves configuration changes and exits the configuration session.</li> <li>• <b>No</b> —Exits the configuration session without committing the configuration changes.</li> <li>• <b>Cancel</b> —Remains in the configuration session, without committing the configuration changes.</li> </ul>

## Activate Graceful Maintenance on a Group of Neighbors

Use the following steps to activate Graceful Maintenance on a group of neighbors:

### SUMMARY STEPS

1. **configure**
2. **router bgp** *as-number*
3. **neighbor-group** *Neighbor-group name*
4. **graceful-maintenance activate**
5. Use the **commit** or **end** command.

### DETAILED STEPS

	Command or Action	Purpose
<b>Step 1</b>	<b>configure</b> <b>Example:</b>  RP/0/# configure	Enters mode.
<b>Step 2</b>	<b>router bgp</b> <i>as-number</i> <b>Example:</b>  Router(config)# router bgp 120	Specifies the BGP AS number and enters the BGP configuration mode, allowing you to configure the BGP routing process.
<b>Step 3</b>	<b>neighbor-group</b> <i>Neighbor-group name</i> <b>Example:</b>  Router(config-bgp)# neighbor-group AS_1	Places the router in neighbor group configuration mode.
<b>Step 4</b>	<b>graceful-maintenance activate</b> <b>Example:</b>  Router(config-bgp-nbrgrp)# graceful-maintenance activate	Announces routes with Graceful Maintenance attributes.
<b>Step 5</b>	Use the <b>commit</b> or <b>end</b> command.	<p><b>commit</b> —Saves the configuration changes and remains within the configuration session.</p> <p><b>end</b> —Prompts user to take one of these actions:</p> <ul style="list-style-type: none"> <li>• <b>Yes</b> — Saves configuration changes and exits the configuration session.</li> <li>• <b>No</b> —Exits the configuration session without committing the configuration changes.</li> <li>• <b>Cancel</b> —Remains in the configuration session, without committing the configuration changes.</li> </ul>

### What to do next

You must configure the **send-community-gshut-ebgp** command under the neighbor address family of an eBGP neighbor for this router to add the GSHUT community.



---

**Note** Sending GSHUT community may not be desirable under every address family of an eBGP neighbor. To allow you to target GSHUT community to a specific set of address families, use the **send-community-gshut-ebgp** command.

---

## Direct Router to Reduce Route Preference

The BGP Graceful Maintenance feature works only with the availability of alternate paths. You must advertise routes with a lower preference to allow alternate routes to take over before taking down a link or router. Use the following steps to modify the route preference:



---

**Note** Attributes for graceful maintenance are added to a route update message after an outbound policy has been applied to it.

---

---

### Step 1 **configure**

**Example:**

```
RP/0/# configure
Enters mode.
```

### Step 2 **router bgp** *as-number*

**Example:**

```
Router(config)# router bgp 120
```

Specifies the BGP AS number and enters the BGP configuration mode, allowing you to configure the BGP routing process.

### Step 3 **neighbor** *ip-address*

**Example:**

```
Router(config-bgp)# neighbor 172.168.40.24
```

Places the router in neighbor configuration mode for BGP routing and configures the neighbor IP address as a BGP peer.

### Step 4 **remote-as** *as-number*

**Example:**

```
Router(config-bgp-nbr)# remote-as 2002
```

Creates a neighbor and assigns a remote autonomous system number to it.

**Step 5** `graceful-maintenance as-prepends value|local-preference value`**Example:**

```
Router(config-bgp-nbr)# graceful-maintenance
local-preference 4
```

Specifies the number of times the local AS number is to be prepended to the AS path of routes and advertises the GSHUT community with the local preference value specified for the routes. When the router adds the GSHUT community to a route as it advertises it, it also changes the LOCAL\_PREF attribute and prepends the local AS number as specified in the commands. Sending GSHUT provides flexibility in the manner in which neighboring routers handle the lower preference: they can match it in a route policy and do the most appropriate thing with it. On the other hand, in simple networks, it is easier to set local-preference to 0, than to create route policies everywhere else.

**Note** LOCAL\_PREF is not sent to real eBGP neighbors, but sent to confederation member AS eBGP neighbors. To lower the preference to eBGP neighbors, as-prepends value is required.

**Example: Configure route policy matching GSHUT community to lower route preference**

```
route-policy gshut
  if community matches-any gshut then
    set local-preference 0
  endif
  pass
end-policy
```

```
neighbor 666.0.0.3
  address-family ipv4 unicast
    route-policy gshut in
```



**Note** Routes received from a GSHUT neighbor are marked with a GSHUT attribute to distinguish them from routes received with the GSHUT community. When a neighbor is taken out of maintenance, the attribute on its paths is removed, but not the community. The attribute is internal and not sent in BGP messages. It is used to reject routes during path selection.

## Bring Router or Link Back into Service

Before you bring the router or link back into service, you must first activate graceful maintenance and then remove the **activate** configuration.

## Show Command Outputs to Verify BGP Graceful Maintenance

This section lists the show commands you can use to verify that BGP Graceful Maintenance is activated and check related attributes:

Use the **show bgp <IP address>** command to display graceful-shutdown community and the graceful-shut path attribute with BGP graceful maintenance activated:

```
RP/0/0/CPU0:R4#show bgp 5.5.5.5
...
10.10.10.1 from 10.10.10.1 (192.168.0.5)
Received Label 24000
Origin incomplete, metric 0, localpref 100, valid, internal, best, group-best,
import-candidate
Received Path ID 0, Local Path ID 1, version 4
Community: graceful-shutdown
Originator: 192.168.0.5, Cluster list: 192.168.0.1
```

The following is sample output from the **show bgp community graceful-shutdown** command displaying the graceful maintenance feature information:

```
RP/0/0/CPU0:R4#show bgp community graceful-shutdown
BGP router identifier 192.168.0.4, local AS number 4
BGP generic scan interval 60 secs
BGP table state: Active
Table ID: 0xe0000000 RD version: 18
BGP main routing table version 18
BGP scan interval 60 secs
Status codes: s suppressed, d damped, h history, * valid, > best
i - internal, r RIB-failure, S stale, N Nexthop-discard
Origin codes: i - IGP, e - EGP, ? - incomplete
Network Next Hop Metric LocPrf Weight Path
* 5.5.5.5/32 10.10.10.1 88 0 1 ?
Processed 1 prefixes, 1 paths
```

The following is the sample output from the **show bgp neighbors** command with the ip-address and configuration argument and keyword to display graceful maintenance feature attributes:

```
RP/0/0/CPU0:R1#show bgp neighbor 12.12.12.5
...
Graceful Maintenance locally active, Local Pref=45, AS prepends=3
...
For Address Family: IPv4 Unicast
...
GSHUT Community attribute sent to this neighbor
...
*****
RP/0/0/CPU0:R1#show bgp neighbor 12.12.12.5 configuration
neighbor 12.12.12.5
remote-as 1 []
graceful-maintenance 1 []
gr-maint local-preference 45 []
gr-maint as-prepends 3 []
gr-maint activate []
```

The following is the sample output of the **show rpl community-set** command with graceful maintenance feature attributes displayed:

```
RP/0/0/CPU0:R5#show rpl community-set
Listing for all Community Set objects
community-set gshut
graceful-shutdown
end-set
```

The following is the sample of the syslog that is issued when a BGP neighbor that has graceful maintenance activated, comes up. It is a warning text that reminds you to deactivate graceful maintenance after convergence.

```
RP/0/0/CPU0:Jan 28 22:01:36.356 : bgp[1056]: %ROUTING-BGP-5-ADJCHANGE : neighbor 10.10.10.4
Up (VRF: default) (AS: 4)
WARNING: Graceful Maintenance is Active
```

## Bring Router or Link Back into Service

Before you bring the router or link back into service, you must first activate graceful maintenance and then remove the **activate** configuration.

## Show Command Outputs to Verify BGP Graceful Maintenance

This section lists the show commands you can use to verify that BGP Graceful Maintenance is activated and check related attributes:

Use the **show bgp <IP address>** command to display graceful-shutdown community and the graceful-shut path attribute with BGP graceful maintenance activated:

```
RP/0/0/CPU0:R4#show bgp 5.5.5.5
...
10.10.10.1 from 10.10.10.1 (192.168.0.5)
Received Label 24000
Origin incomplete, metric 0, localpref 100, valid, internal, best, group-best,
import-candidate
Received Path ID 0, Local Path ID 1, version 4
Community: graceful-shutdown
Originator: 192.168.0.5, Cluster list: 192.168.0.1
```

The following is sample output from the **show bgp community graceful-shutdown** command displaying the graceful maintenance feature information:

```
RP/0/0/CPU0:R4#show bgp community graceful-shutdown
BGP router identifier 192.168.0.4, local AS number 4
BGP generic scan interval 60 secs
BGP table state: Active
Table ID: 0xe0000000 RD version: 18
BGP main routing table version 18
BGP scan interval 60 secs
Status codes: s suppressed, d damped, h history, * valid, > best
i - internal, r RIB-failure, S stale, N Nexthop-discard
Origin codes: i - IGP, e - EGP, ? - incomplete
Network Next Hop Metric LocPrf Weight Path
* 5.5.5.5/32 10.10.10.1 88 0 1 ?
Processed 1 prefixes, 1 paths
```

The following is the sample output from the **show bgp neighbors** command with the ip-address and configuration argument and keyword to display graceful maintenance feature attributes:

```
RP/0/0/CPU0:R1#show bgp neighbor 12.12.12.5
...
Graceful Maintenance locally active, Local Pref=45, AS prepends=3
...
For Address Family: IPv4 Unicast
...
GSHUT Community attribute sent to this neighbor
...
*****
RP/0/0/CPU0:R1#show bgp neighbor 12.12.12.5 configuration
neighbor 12.12.12.5
remote-as 1 []
graceful-maintenance 1 []
gr-maint local-preference 45 []
gr-maint as-prepends 3 []
gr-maint activate []
```



The following is the sample output of the **show rpl community-set** command with graceful maintenance feature attributes displayed:

```
RP/0/0/CPU0:R5#show rpl community-set
Listing for all Community Set objects
community-set gshut
graceful-shutdown
end-set
```

The following is the sample of the syslog that is issued when a BGP neighbor that has graceful maintenance activated, comes up. It is a warning text that reminds you to deactivate graceful maintenance after convergence.

```
RP/0/0/CPU0:Jan 28 22:01:36.356 : bgp[1056]: %ROUTING-BGP-5-ADJCHANGE : neighbor 10.10.10.4
Up (VRF: default) (AS: 4)
WARNING: Graceful Maintenance is Active
```

## Flow-tag propagation

The flow-tag propagation feature enables you to establish a co-relation between route-policies and user-policies. Flow-tag propagation using BGP allows user-side traffic-steering based on routing attributes such as, AS number, prefix lists, community strings and extended communities. Flow-tag is a logical numeric identifier that is distributed through RIB as one of the routing attribute of FIB entry in the FIB lookup table. A flow-tag is instantiated using the 'set' operation from RPL and is referenced in the C3PL PBR policy, where it is associated with actions (policy-rules) against the flow-tag value.

You can use flow-tag propagation to:

- Classify traffic based on destination IP addresses (using the Community number) or based on prefixes (using Community number or AS number).
- Select a TE-group that matches the cost of the path to reach a service-edge based on customer site service level agreements (SLA).
- Apply traffic policy (TE-group selection) for specific customers based on SLA with its clients.
- Divert traffic to application or cache server.

## Restrictions for Flow-Tag Propagation

Some restrictions are placed with regard to using Quality-of-service Policy Propagation Using Border Gateway Protocol (QPPB) and flow-tag feature together. These include:

- A route-policy can have either 'set qos-group' or 'set flow-tag,' but not both for a prefix-set.
- Route policy for qos-group and route policy flow-tag cannot have overlapping routes. The QPPB and flow tag features can coexist (on same as well as on different interfaces) as long as the route policy used by them do not have any overlapping route.
- Mixing usage of qos-group and flow-tag in route-policy and policy-map is not recommended.

## Source and destination-based flow tag

The source-based flow tag feature allows you to match packets based on the flow-tag assigned to the source address of the incoming packets. Once matched, you can then apply any supported PBR action on this policy.

## Configure Source and Destination-based Flow Tag

This task applies flow-tag to a specified interface. The packets are matched based on the flow-tag assigned to the source address of the incoming packets.



---

**Note** You will not be able to enable both QPPB and flow tag feature simultaneously on an interface.

---

### SUMMARY STEPS

1. **configure**
2. **interface** *type interface-path-id*
3. **ipv4 | ipv6 bgp policy propagation input flow-tag** {destination | source}
4. Use the **commit** or **end** command.

### DETAILED STEPS

---

#### Step 1 **configure**

**Example:**

```
RP/0/# configure
```

Enters mode.

#### Step 2 **interface** *type interface-path-id*

**Example:**

```
Router(config-if)# interface FourHundredGige 0/1/0/0
```

Enters interface configuration mode and associates one or more interfaces to the VRF.

#### Step 3 **ipv4 | ipv6 bgp policy propagation input flow-tag** {destination | source}

**Example:**

```
Router(config-if)# ipv4 bgp policy propagation input flow-tag source
```

Enables flow-tag policy propagation on source or destination IP address on an interface.

#### Step 4 Use the **commit** or **end** command.

**commit** —Saves the configuration changes, and remains within the configuration session.

**end** —Prompts user to take one of these actions:

- **Yes** — Saves configuration changes and exits the configuration session.
  - **No** —Exits the configuration session without committing the configuration changes.
  - **Cancel** —Remains in the configuration mode, without committing the configuration changes.
-

**Example**

The following show commands display outputs with PBR policy applied on the router:

```
show running-config interface gigabitEthernet 0/0/0/12
Thu Feb 12 01:51:37.820 UTC
interface GigabitEthernet0/0/0/12
 service-policy type pbr input flowMatchPolicy
 ipv4 bgp policy propagation input flow-tag source
 ipv4 address 192.5.1.2 255.255.255.0
!

Router#show running-config policy-map type pbr flowMatchPolicy
Thu Feb 12 01:51:45.776 UTC
policy-map type pbr flowMatchPolicy
 class type traffic flowMatch36
   transmit
   !
 class type traffic flowMatch38
   transmit
   !
 class type traffic class-default
   !
end-policy-map
!

Router#show running-config class-map type traffic flowMatch36
Thu Feb 12 01:52:04.838 UTC
class-map type traffic match-any flowMatch36
 match flow-tag 36
end-class-map
!
```

## Configure Keychains for BGP

Keychains provide secure authentication by supporting different MAC authentication algorithms and provide graceful key rollover. Perform this task to configure keychains for BGP. This task is optional.



---

**Note** If a keychain is configured for a neighbor group or a session group, a neighbor using the group inherits the keychain. Values of commands configured specifically for a neighbor override inherited values.

---

**Step 1** **configure****Example:**

```
RP/0/# configure
Enters mode.
```

**Step 2** **router bgp** *as-number***Example:**

```
Router(config)# router bgp 120
```

Specifies the autonomous system number and enters the BGP configuration mode, allowing you to configure the BGP routing process.

**Step 3** **neighbor** *ip-address*

**Example:**

```
Router(config-bgp)# neighbor 172.168.40.24
```

Places the router in neighbor configuration mode for BGP routing and configures the neighbor IP address as a BGP peer.

**Step 4** **remote-as** *as-number*

**Example:**

```
Router(config-bgp-nbr)# remote-as 2002
```

Creates a neighbor and assigns a remote autonomous system number to it.

**Step 5** **keychain** *name*

**Example:**

```
Router(config-bgp-nbr)# keychain kych_a
```

Configures keychain-based authentication.

**Step 6** Use the **commit** or **end** command.

**commit** —Saves the configuration changes and remains within the configuration session.

**end** —Prompts user to take one of these actions:

- **Yes** — Saves configuration changes and exits the configuration session.
- **No** —Exits the configuration session without committing the configuration changes.
- **Cancel** —Remains in the configuration session, without committing the configuration changes.

## Configuring an MDT Address Family Session in BGP

Perform this task to configure an IPv4 multicast distribution tree (MDT) subaddress family identifier (SAFI) session in BGP, which can also be used for MVPNv6 network distribution.

### SUMMARY STEPS

1. **configure**
2. **router bgp** *as-number*
3. **address-family** { **ipv4** | **ipv6** } **unicast**
4. **exit**
5. **address-family** { **vpn4** | **vpn6** } **unicast**
6. **exit**
7. **address-family ipv4 mdt**
8. **exit**
9. **neighbor** *ip-address*
10. **remote-as** *as-number*

11. **update-source** *interface-type interface-id*
12. **address-family** { **ipv4** | **ipv6** } **unicast**
13. **exit**
14. **address-family** { **vpn4** | **vpn6** } **unicast**
15. **exit**
16. **address-family** **ipv4** **mdt**
17. **exit**
18. **vrf** *vrf-name*
19. **rd** { *as-number:nn* | *ip-address:nn* | **auto** }
20. **address-family** { **ipv4** | **ipv6** } **unicast**
21. Do one of the following:
  - **redistribute connected** [ **metric** *metric-value* ] [ **route-policy** *route-policy-name* ]
  - **redistribute eigrp** *process-id* [ **match** { **external** | **internal** } ] [ **metric** *metric-value* ] [ **route-policy** *route-policy-name* ]
  - **redistribute isis** *process-id* [ **level** { **1** | **1-inter-area** | **2** } ] [ **metric** *metric-value* ] [ **route-policy** *route-policy-name* ]
  - **redistribute ospf** *process-id* [ **match** { **external** [ **1** | **2** ] | **internal** | **nssa-external** [ **1** | **2** ] } ] [ **metric** *metric-value* ] [ **route-policy** *route-policy-name* ]
  - **redistribute ospfv3** *process-id* [ **match** { **external** [ **1** | **2** ] | **internal** | **nssa-external** [ **1** | **2** ] } ] [ **metric** *metric-value* ] [ **route-policy** *route-policy-name* ]
  - **redistribute rip** [ **metric** *metric-value* ] [ **route-policy** *route-policy-name* ]
  - **redistribute static** [ **metric** *metric-value* ] [ **route-policy** *route-policy-name* ]
22. Use the **commit** or **end** command.

## DETAILED STEPS

	Command or Action	Purpose
<b>Step 1</b>	<b>configure</b> <b>Example:</b> RP/0/# <code>configure</code>	Enters mode.
<b>Step 2</b>	<b>router bgp</b> <i>as-number</i> <b>Example:</b> Router(config)# <code>router bgp 120</code>	Specifies the autonomous system number and enters the BGP configuration mode, allowing you to configure the BGP routing process.
<b>Step 3</b>	<b>address-family</b> { <b>ipv4</b>   <b>ipv6</b> } <b>unicast</b> <b>Example:</b> Router(config-vrf)# <code>address-family ipv4 unicast</code>	Specifies either an IPv4 or IPv6 address family unicast and enters address family configuration submenu.  To see a list of all the possible keywords and arguments for this command, use the CLI help (?).
<b>Step 4</b>	<b>exit</b> <b>Example:</b> Router(config-bgp-af)# <code>exit</code>	Exits the current configuration mode.

	Command or Action	Purpose
<b>Step 5</b>	<b>address-family { vpnv4   vpnv6 } unicast</b> <b>Example:</b> <pre>Router(config-bgp)# address-family vpnv4 unicast</pre>	<p>Specifies the address family and enters the address family configuration submode.</p> <p>To see a list of all the possible keywords and arguments for this command, use the CLI help (?).</p> <p><b>Note</b> Required if you are configuring multicast MVPN. If configuring MVPNv6, use the <b>vpnv6</b> keyword</p>
<b>Step 6</b>	<b>exit</b> <b>Example:</b> <pre>Router(config-bgp-af)# exit</pre>	Exits the current configuration mode.
<b>Step 7</b>	<b>address-family ipv4 mdt</b> <b>Example:</b> <pre>Router(config-bgp)# address-family ipv4 mdt</pre>	Specifies the multicast distribution tree (MDT) address family.
<b>Step 8</b>	<b>exit</b> <b>Example:</b> <pre>Router(config-bgp-af)# exit</pre>	Exits the current configuration mode.
<b>Step 9</b>	<b>neighbor ip-address</b> <b>Example:</b> <pre>Router(config-bgp)# neighbor 172.168.40.24</pre>	Places the router in neighbor configuration mode for BGP routing and configures the neighbor IP address as a BGP peer.
<b>Step 10</b>	<b>remote-as as-number</b> <b>Example:</b> <pre>Router(config-bgp-nbr)# remote-as 2002</pre>	Creates a neighbor and assigns a remote autonomous system number to it.
<b>Step 11</b>	<b>update-source interface-type interface-id</b> <b>Example:</b> <pre>Router(config-bgp-nbr)# update-source loopback 0</pre>	<p>Allows sessions to use the primary IP address from a specific interface as the local address when forming a session with a neighbor.</p> <p>The <i>interface-type interface-id</i> arguments specify the type and ID number of the interface, such as ATM, POS, Loopback. Use the CLI help (?) to see a list of all the possible interface types and their ID numbers.</p>
<b>Step 12</b>	<b>address-family { ipv4   ipv6 } unicast</b> <b>Example:</b> <pre>Router(config-vrf)# address-family ipv4 unicast</pre>	<p>Specifies either an IPv4 or IPv6 address family unicast and enters address family configuration submode.</p> <p>To see a list of all the possible keywords and arguments for this command, use the CLI help (?).</p>
<b>Step 13</b>	<b>exit</b> <b>Example:</b> <pre>Router(config-bgp-nbr-af)# exit</pre>	(Optional) Exits the current configuration mode.

	Command or Action	Purpose
Step 14	<b>address-family { vpvv4   vpvv6 } unicast</b> <b>Example:</b> <pre>Router(config-bgp-nbr)# address-family vpvv4 unicast</pre>	(Optional) Enters address family configuration submode for the specified address family. <b>Note</b> Required if you are configuring multicast MVPN. If configuring MVPNV6, use the <b>vpvv6</b> keyword.
Step 15	<b>exit</b> <b>Example:</b> <pre>Router(config-bgp-nbr-af)# exit</pre>	Exits the current configuration mode.
Step 16	<b>address-family ipv4 mdt</b> <b>Example:</b> <pre>Router(config-bgp)# address-family ipv4 mdt</pre>	Specifies the multicast distribution tree (MDT) address family.
Step 17	<b>exit</b> <b>Example:</b> <pre>Router(config-bgp-af)# exit</pre>	Exits the current configuration mode.
Step 18	<b>vrf vrf-name</b> <b>Example:</b> <pre>Router(config-bgp)# vrf vpv1</pre>	(Optional) Enables BGP routing for a particular VRF on the PE router. <b>Note</b> Required if you are configuring multicast MVPN.
Step 19	<b>rd { as-number:nn   ip-address:nn   auto }</b> <b>Example:</b> <pre>Router(config-bgp-vrf)# rd 1:1</pre>	(Optional) Configures the route distinguisher. <ul style="list-style-type: none"> <li>• Use the <b>auto</b> keyword if you want the router to automatically assign a unique RD to the VRF.</li> <li>• Automatic assignment of RDs is possible only if a router ID is configured using the <b>bgp router-id</b> command in router configuration mode. This allows you to configure a globally unique router ID that can be used for automatic RD generation.</li> </ul> <p>The router ID for the VRF does not need to be globally unique, and using the VRF router ID would be incorrect for automatic RD generation. Having a single router ID also helps in checkpointing RD information for BGP graceful restart, because it is expected to be stable across reboots.</p> <b>Note</b> Required if you are configuring multicast MVPN.
Step 20	<b>address-family { ipv4   ipv6 } unicast</b> <b>Example:</b> <pre>Router(config-vrf)# address-family ipv4 unicast</pre>	Specifies either an IPv4 or IPv6 address family unicast and enters address family configuration submode. To see a list of all the possible keywords and arguments for this command, use the CLI help (?).

	Command or Action	Purpose
<p><b>Step 21</b></p>	<p>Do one of the following:</p> <ul style="list-style-type: none"> <li>• <b>redistribute connected</b> [ <b>metric</b> <i>metric-value</i> ] [ <b>route-policy</b> <i>route-policy-name</i> ]</li> <li>• <b>redistribute eigrp</b> <i>process-id</i> [ <b>match</b> { <b>external</b>   <b>internal</b> } ] [ <b>metric</b> <i>metric-value</i> ] [ <b>route-policy</b> <i>route-policy-name</i> ]</li> <li>• <b>redistribute isis</b> <i>process-id</i> [ <b>level</b> { <b>1</b>   <b>1-inter-area</b>   <b>2</b> } ] [ <b>metric</b> <i>metric-value</i> ] [ <b>route-policy</b> <i>route-policy-name</i> ]</li> <li>• <b>redistribute ospf</b> <i>process-id</i> [ <b>match</b> { <b>external</b> [ <b>1</b>   <b>2</b> ]   <b>internal</b>   <b>nssa-external</b> [ <b>1</b>   <b>2</b> ] } ] [ <b>metric</b> <i>metric-value</i> ] [ <b>route-policy</b> <i>route-policy-name</i> ]</li> <li>• <b>redistribute ospfv3</b> <i>process-id</i> [ <b>match</b> { <b>external</b> [ <b>1</b>   <b>2</b> ]   <b>internal</b>   <b>nssa-external</b> [ <b>1</b>   <b>2</b> ] } ] [ <b>metric</b> <i>metric-value</i> ] [ <b>route-policy</b> <i>route-policy-name</i> ]</li> <li>• <b>redistribute rip</b> [ <b>metric</b> <i>metric-value</i> ] [ <b>route-policy</b> <i>route-policy-name</i> ]</li> <li>• <b>redistribute static</b> [ <b>metric</b> <i>metric-value</i> ] [ <b>route-policy</b> <i>route-policy-name</i> ]</li> </ul> <p><b>Example:</b></p> <pre>Router(config-bgp-vrf-af)# redistribute eigrp 23</pre>	<p>(Optional) Configures redistribution of a protocol into the VRF address family context.</p> <p><b>Note</b> Required if you are configuring multicast MVPN.</p>
<p><b>Step 22</b></p>	<p>Use the <b>commit</b> or <b>end</b> command.</p>	<p><b>commit</b> —Saves the configuration changes and remains within the configuration session.</p> <p><b>end</b> —Prompts user to take one of these actions:</p> <ul style="list-style-type: none"> <li>• <b>Yes</b> — Saves configuration changes and exits the configuration session.</li> <li>• <b>No</b> —Exits the configuration session without committing the configuration changes.</li> <li>• <b>Cancel</b> —Remains in the configuration session, without committing the configuration changes.</li> </ul>

## Disable BGP Neighbor

Perform this task to administratively shut down a neighbor session without removing the configuration.

### SUMMARY STEPS

1. **configure**
2. **router bgp** *as-number*
3. **neighbor** *ip-address*



4. **shutdown**
5. Use the **commit** or **end** command.

## DETAILED STEPS

---

### Step 1 **configure**

**Example:**

```
RP/0/# configure
Enters mode.
```

### Step 2 **router bgp** *as-number*

**Example:**

```
Router(config)# router bgp 127
```

Specifies the autonomous system number and enters the BGP configuration mode, allowing you to configure the BGP routing process.

### Step 3 **neighbor** *ip-address*

**Example:**

```
Router(config-bgp)# neighbor 172.168.40.24
```

Places the router in neighbor configuration mode for BGP routing and configures the neighbor IP address as a BGP peer.

### Step 4 **shutdown**

**Example:**

```
Router(config-bgp-nbr)# shutdown
```

Disables all active sessions for the specified neighbor.

### Step 5 Use the **commit** or **end** command.

**commit** —Saves the configuration changes and remains within the configuration session.

**end** —Prompts user to take one of these actions:

- **Yes** — Saves configuration changes and exits the configuration session.
  - **No** —Exits the configuration session without committing the configuration changes.
  - **Cancel** —Remains in the configuration session, without committing the configuration changes.
- 

## Neighbor Capability Suppression

A BGP speaker can learn about BGP extensions that are supported by a peer by using the capabilities negotiation feature. Capabilities negotiation allows BGP to use only the set of features supported by both BGP peers on a link. The neighbor capability suppression feature will turn off neighbor capabilities negotiation during Open

message exchange. This is required for interoperability with very old customer premises equipment devices that do not understand Capabilities option.

## Configuration

Command introduced in neighbor, session-group and neighbor-group modes.

### SUMMARY STEPS

1. **configure**
2. **router bgp** *as-number*
3. **neighbor** *ip-address*
4. **capability suppress all**
5. Use the **commit** or **end** command.

### DETAILED STEPS

	Command or Action	Purpose
<b>Step 1</b>	<b>configure</b> <b>Example:</b>  RP/0/# configure	Enters mode.
<b>Step 2</b>	<b>router bgp</b> <i>as-number</i> <b>Example:</b>  Router(config)# router bgp 4	Specifies the autonomous system number and enters the BGP configuration mode, allowing you to configure the BGP routing process.
<b>Step 3</b>	<b>neighbor</b> <i>ip-address</i> <b>Example:</b>  Router(config-bgp)# neighbor 172.168.40.24	Places the router in neighbor configuration mode for BGP routing and configures the neighbor IP address as a BGP peer.
<b>Step 4</b>	<b>capability suppress all</b> <b>Example:</b>  Router(config-bgp-nbr)# capability suppress all	Turn off neighbor capabilities.
<b>Step 5</b>	Use the <b>commit</b> or <b>end</b> command.	<p><b>commit</b> —Saves the configuration changes and remains within the configuration session.</p> <p><b>end</b> —Prompts user to take one of these actions:</p> <ul style="list-style-type: none"> <li>• <b>Yes</b> — Saves configuration changes and exits the configuration session.</li> <li>• <b>No</b> —Exits the configuration session without committing the configuration changes.</li> <li>• <b>Cancel</b> —Remains in the configuration session, without committing the configuration changes.</li> </ul>

# BGP Dynamic Neighbors

Earlier IOS-XR supported explicitly configured or static neighbor configuration. BGP dynamic neighbor support allows BGP peering to a group of remote neighbors that are defined by a range of IP addresses. Each range can be configured as a subnet IP address.

In larger BGP networks, implementing BGP dynamic neighbors can reduce the amount and complexity of CLI configuration and save CPU and memory usage. Both IPv4 and IPv6 peering are supported. Both IPv4 and IPv6 peering are supported.

## Configuring BGP Dynamic Neighbors using Address Range

The existing neighbor command is extended to accept a prefix instead of an address.

In the following task, Router B is configured as a remote BGP peer. After a subnet range is configured, a TCP session is initiated by Router B which has an IP address in the subnet range and a new BGP neighbor is dynamically established.

After the initial configuration of subnet ranges and activation of the peer neighbor, dynamic BGP neighbor creation does not require any further CLI configuration on the Router A.



### Step 1 **configure**

#### **Example:**

```
Router# configure
```

Enters the global configuration mode.

### Step 2 **router bgp *as-number***

#### **Example:**

```
Router(config)# router bgp 100
```

Specifies the autonomous system number and enters the BGP configuration mode, allowing you to configure the BGP routing process.

### Step 3 **neighbor *address prefix***

#### **Example:**

```
Router(config-bgp)# neighbor 10.0.0.0/16
```

Places the router in neighbor configuration mode for BGP routing and configures the BGP dynamic neighbor within the subnet range.

**Note** All commands currently supported under a static neighbor, including address-family and inheritance using neighbor-group, session-group and af-group, will be supported for dynamic neighbor ranges with the exception of the following commands:

- session-open-mode
- local address

**Step 4** `remote-as as-number`

**Example:**

```
Router(config-bgp-nbr)# remote-as 1
```

Creates a neighbor and assigns a remote autonomous system (AS) number to it.

**Step 5** `update-source type interface-id`

**Example:**

```
Router(config-bgp-nbr)# update-source FourHundredGige 0/0/0/0
```

Allows sessions to use the primary IP address from a specific interface as the local address when forming a session with a neighbor.

The type and interface-id arguments specify the type and ID number of the interface. Use the CLI help (?) to see a list of all the possible interface types and their ID numbers.

**Step 6** `address-family ipv4 unicast`

**Example:**

```
Router(config-bgp-nbr)# address-family ipv4 unicast
```

Specifies the IPv4 unicast address family unicast and enters address family configuration mode.

**Step 7** Use the **commit** or **end** command.

**commit** - Saves the configuration changes and remains within the configuration session.

**end** - Prompts user to take one of these actions:

- **Yes** - Saves configuration changes and exits the configuration session.
- **No** - Exits the configuration session without committing the configuration changes.
- **Cancel** - Remains in the configuration mode, without committing the configuration changes.

---

## Remote AS List

In the following task, Router B and Router C are configured as a remote BGP peers. Both Router B and Router C are in different autonomous systems.

A list is created with the autonomous system of the remote routers and the list is then configured under neighbor mode using **remote-as-list** command.

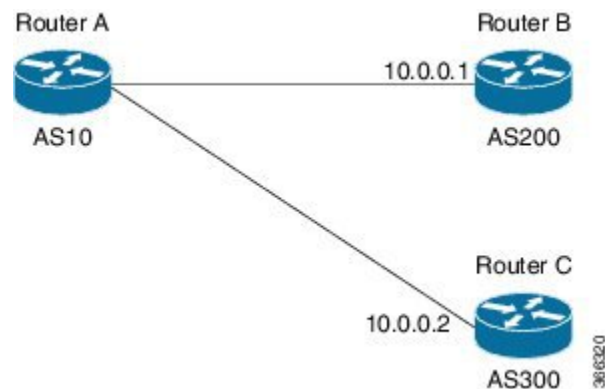

### Configuration

```

Router# configure
Router(config)# router bgp as-number
Router(config-bgp)# as-list name
Router(config-bgp)# neighbor address prefix
Router(config-bgp-nbr)# remote-as-list name
Router(config-bgp-nbr)# address-family ipv4 unicast
Router# commit
  
```

## Maximum-peers and Idle-watch timeout

In the below task, maximum-peers and idle-watch timeout commands are configured for a remote BGP peer.

### Step 1 **configure**

#### Example:

```
Router# configure
```

Enters the global configuration mode.

### Step 2 **router bgp as-number**

#### Example:

```
Router(config)# router bgp 10
```

Specifies the autonomous system number and enters the BGP configuration mode, allowing you to configure the BGP routing process.

### Step 3 **neighbor address prefix**

#### Example:

```
Router(config-bgp)# neighbor 10.0.0.0/16
```

Places the router in neighbor configuration mode for BGP routing and configures the BGP dynamic neighbor within the subnet range.

### Step 4 **maximum-peers number**

#### Example:

```
Router(config-bgp-nbr)# maximum-peers 16
```

This is used to configure an upper limit on the number of dynamic neighbor instances allowed under a range.

**Step 5** `idle-watch-time number`

**Example:**

```
Router(config-bgp)# idle-watch-time 120
```

Configures the time to wait before deleting an idle TCP instance.

**Step 6** Use the `commit` or `end` command.

**commit** —Saves the configuration changes and remains within the configuration session.

**end** —Prompts user to take one of these actions:

- **Yes** — Saves configuration changes and exits the configuration session.
- **No** —Exits the configuration session without committing the configuration changes.
- **Cancel** —Remains in the configuration session, without committing the configuration changes.

---

## Resetting Neighbors Using BGP Inbound Soft Reset

Perform this task to trigger an inbound soft reset of the specified address families for the specified group or neighbors. The group is specified by the `*`, `ip-address`, `as-number`, or `external` keywords and arguments.

Resetting neighbors is useful if you change the inbound policy for the neighbors or any other configuration that affects the sending or receiving of routing updates. If an inbound soft reset is triggered, BGP sends a REFRESH request to the neighbor if the neighbor has advertised the ROUTE\_REFRESH capability. To determine whether the neighbor has advertised the ROUTE\_REFRESH capability, use the `show bgp neighbors` command.

---

**Step 1** `show bgp neighbors`

**Example:**

```
Router# show bgp neighbors
```

Verifies that received route refresh capability from the neighbor is enabled.

**Step 2** `soft [ in [ prefix-filter ] | out ]`

**Example:**

```
Router# clear bgp ipv4 unicast 10.0.0.1 soft in
```

Soft resets a BGP neighbor.

- The `*` keyword resets all BGP neighbors.
- The `ip-address` argument specifies the address of the neighbor to be reset.
- The `as-number` argument specifies that all neighbors that match the autonomous system number be reset.

- The **external** keyword specifies that all external neighbors are reset.

---

## Resetting Neighbors Using BGP Outbound Soft Reset

Perform this task to trigger an outbound soft reset of the specified address families for the specified group or neighbors. The group is specified by the **\***, *ip-address*, *as-number*, or **external** keywords and arguments.

Resetting neighbors is useful if you change the outbound policy for the neighbors or any other configuration that affects the sending or receiving of routing updates.

If an outbound soft reset is triggered, BGP resends all routes for the address family to the given neighbors.

To determine whether the neighbor has advertised the ROUTE\_REFRESH capability, use the **show bgp neighbors** command.

---

### Step 1 show bgp neighbors

#### Example:

```
Router# show bgp neighbors
```

Verifies that received route refresh capability from the neighbor is enabled.

### Step 2 clear bgp ipv4 unicast *ip-address* soft out

#### Example:

```
Router# clear bgp ipv4 unicast 10.0.0.2 soft out
```

Soft resets a BGP neighbor.

- The **\*** keyword resets all BGP neighbors.
- The *ip-address* argument specifies the address of the neighbor to be reset.
- The *as-number* argument specifies that all neighbors that match the autonomous system number be reset.
- The **external** keyword specifies that all external neighbors are reset.

---

## Reset Neighbors Using BGP Hard Reset

Perform this task to reset neighbors using a hard reset. A hard reset removes the TCP connection to the neighbor, removes all routes received from the neighbor from the BGP table, and then re-establishes the session with the neighbor. If the **graceful** keyword is specified, the routes from the neighbor are not removed from the BGP table immediately, but are marked as stale. After the session is re-established, any stale route that has not been received again from the neighbor is removed.

---

```
clear bgp { ipv4 { unicast | labeled-unicast | all | tunnel tunnel | mdt } | ipv6 unicast | all | labeled-unicast
} | all { unicast | multicast | all | labeled-unicast | mdt | tunnel } | vpnv4 unicast | vrf { vrf-name | all } {
ipv4 unicast | labeled-unicast } | vpnv6 unicast } { * | ip-address | as as-number | external
} [ graceful ] soft [ in [ prefix-filter ] | out ] clear bgp { ipv4 | ipv6 } { unicast | labeled-unicast }
```

**Example:**

```
Router# clear bgp ipv4 unicast 10.0.0.3 graceful soft out
```

Clears a BGP neighbor.

- The `*` keyword resets all BGP neighbors.
- The `ip-address` argument specifies the address of the neighbor to be reset.
- The `as-number` argument specifies that all neighbors that match the autonomous system number be reset.
- The `external` keyword specifies that all external neighbors are reset.

The `graceful` keyword specifies a graceful restart.

---

## Clearing Caches, Tables, and Databases

Perform this task to remove all contents of a particular cache, table, or database. The `clear bgp` command resets the sessions of the specified group of neighbors (hard reset); it removes the TCP connection to the neighbor, removes all routes received from the neighbor from the BGP table, and then re-establishes the session with the neighbor. Clearing a cache, table, or database can become necessary when the contents of the particular structure have become, or are suspected to be, invalid.

---

**Step 1** `clear bgp ipv4 ip-address`

**Example:**

```
Router# clear bgp ipv4 172.20.1.1
```

Clears a specified neighbor.

**Step 2** `clear bgp external`

**Example:**

```
Router# clear bgp external
```

Clears all external peers.

**Step 3** `clear bgp *`

**Example:**

```
Router# clear bgp *
```



Clears all BGP neighbors.

---

## Display System and Network Statistics

Perform this task to display specific statistics, such as the contents of BGP routing tables, caches, and databases. Information provided can be used to determine resource usage and solve network problems. You can also display information about node reachability and discover the routing path that the packets of your device are taking through the network.

### SUMMARY STEPS

1. **show bgp cidr-only**
2. **show bgp community** *community-list* [ **exact-match** ]
3. **show bgp regexp** *regular-expression*
4. **show bgp**
5. **show bgp neighbors** *ip-address* [ **advertised-routes** | **dampened-routes** | **flap-statistics** | **performance-statistics** | **received** *prefix-filter* | **routes** ]
6. **show bgp paths**
7. **show bgp neighbor-group** *group-name* **configuration**
8. **show bgp summary**

### DETAILED STEPS

---

#### Step 1 **show bgp cidr-only**

**Example:**

```
Router# show bgp cidr-only
```

Displays routes with nonnatural network masks (classless interdomain routing [CIDR]) routes.

#### Step 2 **show bgp community** *community-list* [ **exact-match** ]

**Example:**

```
Router# show bgp community 1081:5 exact-match
```

Displays routes that match the specified BGP community.

#### Step 3 **show bgp regexp** *regular-expression*

**Example:**

```
Router# show bgp regexp "^3 "
```

Displays routes that match the specified autonomous system path regular expression.

#### Step 4 **show bgp**

**Example:**

```
Router# show bgp
```

Displays entries in the BGP routing table.

**Step 5** **show bgp neighbors** *ip-address* [ **advertised-routes** | **dampened-routes** | **flap-statistics** | **performance-statistics** | **received** *prefix-filter* | **routes** ]

**Example:**

```
Router# show bgp neighbors 10.0.101.1
```

Displays information about the BGP connection to the specified neighbor.

- The **advertised-routes** keyword displays all routes the router advertised to the neighbor.
- The **dampened-routes** keyword displays the dampened routes that are learned from the neighbor.
- The **flap-statistics** keyword displays flap statistics of the routes learned from the neighbor.
- The **performance-statistics** keyword displays performance statistics relating to work done by the BGP process for this neighbor.
- The **received** *prefix-filter* keyword and argument display the received prefix list filter.
- The **routes** keyword displays routes learned from the neighbor.

**Step 6** **show bgp paths**

**Example:**

```
Router# show bgp paths
```

Displays all BGP paths in the database.

**Step 7** **show bgp neighbor-group** *group-name* **configuration**

**Example:**

```
Router# show bgp neighbor-group group_1 configuration
```

Displays the effective configuration for a specified neighbor group, including any configuration inherited by this neighbor group.

**Step 8** **show bgp summary**

**Example:**

```
Router# show bgp summary
```

Displays the status of all BGP connections.

---

## Display BGP Process Information

Perform this task to display specific BGP process information.

---

**Step 1** **show bgp process**

**Example:**

```
Router# show bgp process
```

Displays status and summary information for the BGP process. The output shows various global and address family-specific BGP configurations. A summary of the number of neighbors, update messages, and notification messages sent and received by the process is also displayed.

**Step 2**    **show bgp ipv4 unicast summary****Example:**

```
Router# show bgp ipv4 unicast summary
```

Displays a summary of the neighbors for the IPv4 unicast address family.

**Step 3**    **show bgp vpnv4 unicast summary****Example:**

```
Router# show bgp vpnv4 unicast summary
```

Displays a summary of the neighbors for the VPNv4 unicast address family.

**Step 4**    **show bgp vrf ( vrf-name | all )****Example:**

```
Router# show bgp vrf vrf_A
```

Displays BGP VPN virtual routing and forwarding (VRF) information.

**Step 5**    **show bgp process detail****Example:**

```
Router# show bgp processes detail
```

Displays detailed process information including the memory used by each of various internal structure types.

**Step 6**    **show bgp summary****Example:**

```
Router# show bgp summary
```

Displays the status of all BGP connections.

**Step 7**    **show placement program bgp****Example:**

```
Router# show placement program bgp
```

Displays BGP program information.

- If a program is shown as having ‘rejected locations’ (for example, locations where program cannot be placed), the locations in question can be viewed using the **show placement program bgp** command.
- If a program has been placed but not started, the amount of elapsed time since the program was placed is displayed in the Waiting to start column.

**Step 8**    **show placement program brib**

**Example:**

```
Router# show placement program brib
```

Displays bRIB program information.

- If a program is shown as having ‘rejected locations’ (for example, locations where program cannot be placed), the locations in question can be viewed using the **show placement program bgp** command.
- If a program has been placed but not started, the amount of elapsed time since the program was placed is displayed in the Waiting to start column.

---

## Configure iBGP Multipath Load Sharing

Perform this task to configure the iBGP Multipath Load Sharing:

### SUMMARY STEPS

1. **configure**
2. **router bgp** *as-number*
3. **address-family** {**ipv4|ipv6**} {**unicast|multicast**}
4. **maximum-paths ibgp** *number*
5. Use the **commit** or **end** command.

### DETAILED STEPS

---

**Step 1**    **configure****Example:**

```
RP/0/# configure
```

Enters mode.

**Step 2**    **router bgp** *as-number***Example:**

```
Router(config)# router bgp 100
```

Specifies the autonomous system number and enters the BGP configuration mode, allowing you to configure the BGP routing process.

**Step 3**    **address-family** {**ipv4|ipv6**} {**unicast|multicast**}**Example:**

```
Router(config-bgp)# address-family ipv4 multicast
```

Specifies either the IPv4 or IPv6 address family and enters address family configuration submode.

**Step 4**    **maximum-paths ibgp** *number***Example:**

```
Router(config-bgp-af)# maximum-paths ibgp 30
```

Configures the maximum number of iBGP paths for load sharing.

**Step 5** Use the **commit** or **end** command.

**commit** —Saves the configuration changes and remains within the configuration session.

**end** —Prompts user to take one of these actions:

- **Yes** — Saves configuration changes and exits the configuration session.
- **No** —Exits the configuration session without committing the configuration changes.
- **Cancel** —Remains in the configuration session, without committing the configuration changes.

---

### iBGP Multipath Loadsharing Configuration: Example

The following is a sample configuration where 30 paths are used for loadsharing:

```
router bgp 100
  address-family ipv4 multicast
    maximum-paths ibgp 30
  !
!
end
```

## Originate Prefixes with AiGP

Perform this task to configure origination of routes with the AiGP metric:

### Before you begin

Origination of routes with the accumulated interior gateway protocol (AiGP) metric is controlled by configuration. AiGP attributes are attached to redistributed routes that satisfy following conditions:

- The protocol redistributing the route is enabled for AiGP.
- The route is an interior gateway protocol (iGP) route redistributed into border gateway protocol (BGP). The value assigned to the AiGP attribute is the value of iGP next hop to the route or as set by a route-policy.
- The route is a static route redistributed into BGP. The value assigned is the value of next hop to the route or as set by a route-policy.
- The route is imported into BGP through network statement. The value assigned is the value of next hop to the route or as set by a route-policy.

---

**Step 1** **configure**

**Example:**

```
RP/0/# configure
```

Enters mode.

**Step 2** **route-policy** *aigp\_policy*

**Example:**

```
Router(config)# route-policy aigp_policy
```

Enters route-policy configuration mode and sets the route-policy

**Step 3** **set aigp-metric** *igp-cost*

**Example:**

```
Router(config-rpl)# set aigp-metric igp-cost
```

Sets the internal routing protocol cost as the aigp metric.

**Step 4** **exit**

**Example:**

```
Router(config-rpl)# exit
```

Exits route-policy configuration mode.

**Step 5** **router bgp** *as-number*

**Example:**

```
Router(config)# router bgp 100
```

Specifies the BGP AS number and enters the BGP configuration mode, allowing you to configure the BGP routing process.

**Step 6** **address-family** {*ipv4* | *ipv6*} **unicast**

**Example:**

```
Router(config-bgp)# address-family ipv4 unicast
```

Specifies either the IPv4 or IPv6 address family and enters address family configuration submode.

**Step 7** **redistribute ospf** *osp* **route-policy** *plcy\_name* **metric** *value*

**Example:**

```
Router(config-bgp-af)# redistribute ospf osp route-policy aigp_policy metric 1
```

Allows the redistribution of AiBGP metric into OSPF.

**Step 8** Use the **commit** or **end** command.

**commit** —Saves the configuration changes and remains within the configuration session.

**end** —Prompts user to take one of these actions:

- **Yes** — Saves configuration changes and exits the configuration session.
- **No** —Exits the configuration session without committing the configuration changes.
- **Cancel** —Remains in the configuration session, without committing the configuration changes.

**Originating Prefixes With AiGP: Example**

The following is a sample configuration for originating prefixes with the AiGP metric attribute:

```
route-policy aigp-policy
  set aigp-metric 4
  set aigp-metric igp-cost
end-policy
!
router bgp 100
  address-family ipv4 unicast
    network 10.2.3.4/24 route-policy aigp-policy
    redistribute ospf ospf metric 4 route-policy aigp-policy
  !
!
end
```

## Configure BGP Accept Own

Perform this task to configure BGP Accept Own:

**Step 1**    **configure**

**Step 2**    **router bgp** *as-number*

**Example:**

```
Router(config)#router bgp 100
```

Specifies the autonomous system number and enters the BGP configuration mode, allowing you to configure the BGP routing process.

**Step 3**    **neighbor** *ip-address*

**Example:**

```
Router(config-bgp)#neighbor 10.1.2.3
```

Places the router in neighbor configuration mode for BGP routing and configures the neighbor IP address as a BGP peer.

**Step 4**    **remote-as** *as-number*

**Example:**

```
Router(config-bgp-nbr)#remote-as 100
```

Assigns a remote autonomous system number to the neighbor.

**Step 5**    **update-source** *type interface-path-id*

**Example:**

```
Router(config-bgp-nbr)#update-source Loopback0
```

Allows sessions to use the primary IP address from a specific interface as the local address when forming a session with a neighbor.

**Step 6**    **address-family** {*vpn4 unicast* | *vpn6 unicast*}

**Example:**

```
Router(config-bgp-nbr)#address-family vpnv6 unicast
```

Specifies the address family as VPNv4 or VPNv6 and enters neighbor address family configuration mode.

**Step 7** `accept-own [inheritance-disable]`

**Example:**

```
Router(config-bgp-nbr-af)#accept-own
```

Enables handling of self-originated VPN routes containing Accept\_Own community.

Use the **inheritance-disable** keyword to disable the "accept own" configuration and to prevent inheritance of "acceptown" from a parent configuration.

**BGP Accept Own Configuration: Example**

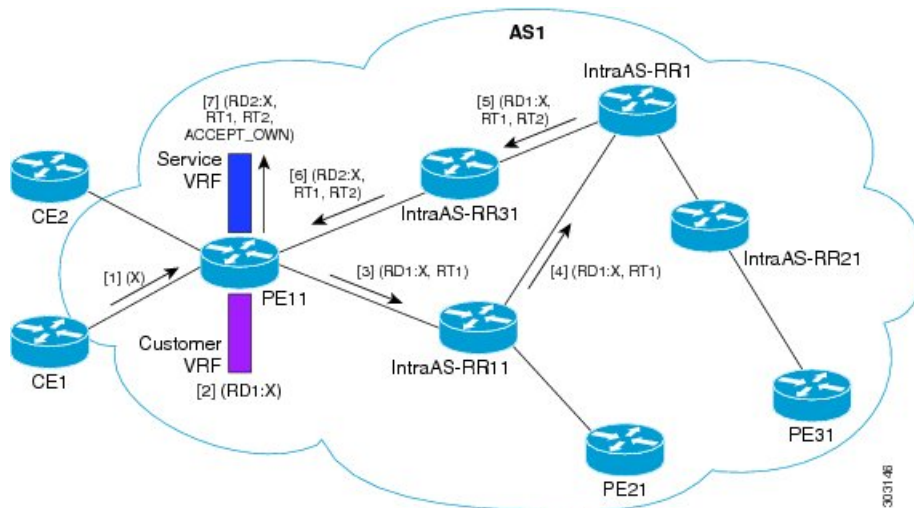

In this configuration example:

- PE11 is configured with Customer VRF and Service VRF.
- OSPF is used as the IGP.
- VPNv4 unicast and VPNv6 unicast address families are enabled between the PE and RR neighbors and IPv4 and IPv6 are enabled between PE and CE neighbors.

The Accept Own configuration works as follows:

1. CE1 originates prefix X.
2. Prefix X is installed in customer VRF as (RD1:X).
3. Prefix X is advertised to IntraAS-RR11 as (RD1:X, RT1).
4. IntraAS-RR11 advertises X to IntraAS-RR1 as (RD1:X, RT1).
5. IntraAS-RR1 attaches RT2 to prefix X on the inbound and ACCEPT\_OWN community on the outbound and advertises prefix X to IntraAS-RR31.



6. IntraAS-RR31 advertises X to PE11.
7. PE11 installs X in Service VRF as (RD2:X,RT1, RT2, ACCEPT\_OWN).

This example shows how to configure BGP Accept Own on a PE router.

```
router bgp 100
 neighbor 45.1.1.1
   remote-as 100
   update-source Loopback0
   address-family vpnv4 unicast
     route-policy pass-all in
     accept-own
     route-policy drop_111.x.x.x out
   !
   address-family vpnv6 unicast
     route-policy pass-all in
     accept-own
     route-policy drop_111.x.x.x out
   !
 !
```

This example shows an InterAS-RR configuration for BGP Accept Own.

```
router bgp 100
 neighbor 45.1.1.1
   remote-as 100
   update-source Loopback0
   address-family vpnv4 unicast
     route-policy rt_stitch1 in
     route-reflector-client
     route-policy add_bgp_ao out
   !
   address-family vpnv6 unicast
     route-policy rt_stitch1 in
     route-reflector-client
     route-policy add_bgp_ao out
   !
 !
 extcommunity-set rt cs_100:1
   100:1
 end-set
 !
 extcommunity-set rt cs_1001:1
   1001:1
 end-set
 !
 route-policy rt_stitch1
   if extcommunity rt matches-any cs_100:1 then
     set extcommunity rt cs_1000:1 additive
   endif
 end-policy
 !
 route-policy add_bgp_ao
   set community (accept-own) additive
 end-policy
 !
```

## Configuring BGP Link-state

To exchange BGP link-state (LS) information with a BGP neighbor, perform these steps:

---

**Step 1** **configure****Example:**

```
RP/0/# configure
```

Enters mode.

**Step 2** **router bgp** *as-number***Example:**

```
Router(config)# router bgp 100
```

Specifies the BGP AS number and enters the BGP configuration mode, allowing you to configure the BGP routing process.

**Step 3** **neighbor** *ip-address***Example:**

```
Router(config-bgp)# neighbor 10.0.0.2
```

Configures a CE neighbor. The *ip-address* argument must be a private address.

**Step 4** **remote-as** *as-number***Example:**

```
Router(config-bgp-nbr)# remote-as 1
```

Configures the remote AS for the CE neighbor.

**Step 5** **address-family link-state link-state****Example:**

```
Router(config-bgp-nbr)# address-family link-state link-state
```

Distributes BGP link-state information to the specified neighbor.

**Step 6** Use the **commit** or **end** command.

**commit** —Saves the configuration changes and remains within the configuration session.

**end** —Prompts user to take one of these actions:

- **Yes** — Saves configuration changes and exits the configuration session.
  - **No** —Exits the configuration session without committing the configuration changes.
  - **Cancel** —Remains in the configuration session, without committing the configuration changes.
-

# Configuring BGP Permanent Network

Perform this task to configure BGP permanent network. You must configure at least one route-policy to identify the set of prefixes (networks) for which the permanent network (path) is to be configured.

---

**Step 1**     **configure****Example:**

```
RP/0/# configure
```

Enters mode.

**Step 2**     **prefix-set** *prefix-set-name***Example:**

```
Router(config)# prefix-set PERMANENT-NETWORK-IPv4
Router(config-pfx)# 1.1.1.1/32,
Router(config-pfx)# 2.2.2.2/32,
Router(config-pfx)# 3.3.3.3/32
Router(config-pfx)# end-set
```

Enters prefix set configuration mode and defines a prefix set for contiguous and non-contiguous set of bits.

**Step 3**     **exit****Example:**

```
Router(config-pfx)# exit
```

Exits prefix set configuration mode and enters global configuration mode.

**Step 4**     **route-policy** *route-policy-name***Example:**

```
Router(config)# route-policy POLICY-PERMANENT-NETWORK-IPv4
Router(config-rpl)# if destination in PERMANENT-NETWORK-IPv4 then
Router(config-rpl)# pass
Router(config-rpl)# endif
```

Creates a route policy and enters route policy configuration mode, where you can define the route policy.

**Step 5**     **end-policy****Example:**

```
Router(config-rpl)# end-policy
```

Ends the definition of a route policy and exits route policy configuration mode.

**Step 6**     **router bgp** *as-number***Example:**

```
Router(config)# router bgp 100
```

Specifies the autonomous system number and enters the BGP configuration mode.

**Step 7** **address-family { ipv4 | ipv6 } unicast**

**Example:**

```
Router(config-bgp)# address-family ipv4 unicast
```

Specifies either an IPv4 or IPv6 address family unicast and enters address family configuration submode.

**Step 8** **permanent-network route-policy route-policy-name**

**Example:**

```
Router(config-bgp-af)# permanent-network route-policy POLICY-PERMANENT-NETWORK-IPv4
```

Configures the permanent network (path) for the set of prefixes as defined in the route-policy.

**Step 9** Use the **commit** or **end** command.

**commit** —Saves the configuration changes and remains within the configuration session.

**end** —Prompts user to take one of these actions:

- **Yes** — Saves configuration changes and exits the configuration session.
- **No** —Exits the configuration session without committing the configuration changes.
- **Cancel** —Remains in the configuration session, without committing the configuration changes.

**Step 10** **show bgp { ipv4 | ipv6 } unicast prefix-set**

**Example:**

```
show bgp ipv4 unicast
```

(Optional) Displays whether the prefix-set is a permanent network in BGP.

---

## How to Advertise Permanent Network

Perform this task to identify the peers to whom the permanent paths must be advertised.

---

**Step 1** **configure**

**Example:**

```
RP/0/# configure
```

Enters mode.

**Step 2** `router bgp as-number`

**Example:**

```
Router(config)# router bgp 100
```

Specifies the autonomous system number and enters the BGP configuration mode.

**Step 3** `neighbor ip-address`

**Example:**

```
Router(config-bgp)# neighbor 10.255.255.254
```

Places the router in neighbor configuration mode for BGP routing and configures the neighbor IP address as a BGP peer.

**Step 4** `remote-as as-number`

**Example:**

```
Router(config-bgp-nbr)# remote-as 4713
```

Assigns the neighbor a remote autonomous system number.

**Step 5** `address-family { ipv4 | ipv6 } unicast`

**Example:**

```
Router(config-bgp-nbr)# address-family ipv4 unicast
```

Specifies either an IPv4 or IPv6 address family unicast and enters address family configuration submode.

**Step 6** `advertise permanent-network`

**Example:**

```
Router(config-bgp-nbr-af)# advertise permanent-network
```

Specifies the peers to whom the permanent network (path) is advertised.

**Step 7** Use the **commit** or **end** command.

**commit** —Saves the configuration changes and remains within the configuration session.

**end** —Prompts user to take one of these actions:

- **Yes** — Saves configuration changes and exits the configuration session.
- **No** —Exits the configuration session without committing the configuration changes.
- **Cancel** —Remains in the configuration session, without committing the configuration changes.

**Step 8** `show bgp { ipv4 | ipv6 } unicast neighbor ip-address`

**Example:**

```
Router#show bgp ipv4 unicast neighbor 10.255.255.254
```

(Optional) Displays whether the neighbor is capable of receiving BGP permanent networks.

# Enable BGP Unequal Cost Recursive Load Balancing

## Procedure

	Command or Action	Purpose
<b>Step 1</b>	<b>configure</b>	
<b>Step 2</b>	<b>router bgp</b> <i>as-number</i> <b>Example:</b> Router(config)# router bgp 120	Specifies the autonomous system number and enters the BGP configuration mode, allowing you to configure the BGP routing process.
<b>Step 3</b>	<b>address-family</b> { <b>ipv4</b>   <b>ipv6</b> } <b>unicast</b> <b>Example:</b> Router(config-bgp)# address-family ipv4 unicast	Specifies either an IPv4 or IPv6 address family unicast and enters address family configuration submenu.  To see a list of all the possible keywords and arguments for this command, use the CLI help (?).
<b>Step 4</b>	<b>maximum-paths</b> { <b>ebgp</b>   <b>ibgp</b>   <b>eibgp</b> } <i>maximum</i> [ <b>unequal-cost</b> ] <b>Example:</b> Router(config-bgp-af)# maximum-paths ebgp 3	Configures the maximum number of parallel routes that BGP installs in the routing table. <ul style="list-style-type: none"> <li>• <b>ebgp</b> <i>maximum</i> : Consider only eBGP paths for multipath.</li> <li>• <b>ibgp</b> <i>maximum</i> [ <b>unequal-cost</b> ]: Consider load balancing between iBGP learned paths.</li> <li>• <b>eibgp</b> <i>maximum</i> : Consider both eBGP and iBGP learned paths for load balancing. eiBGP load balancing always does unequal-cost load balancing.</li> </ul> When eiBGP is applied, eBGP or iBGP load balancing cannot be configured; however, eBGP and iBGP load balancing can coexist.
<b>Step 5</b>	<b>exit</b> <b>Example:</b> Router(config-bgp-af)# exit	Exits the current configuration mode.
<b>Step 6</b>	<b>neighbor</b> <i>ip-address</i> <b>Example:</b> Router(config-bgp)# neighbor 10.0.0.0	Configures a CE neighbor. The <i>ip-address</i> argument must be a private address.

	Command or Action	Purpose
Step 7	<b>dmz-link-bandwidth</b> <b>Example:</b> Router(config-bgp-nbr)# dmz-link-bandwidth	Originates a demilitarized-zone (DMZ) link-bandwidth extended community for the link to an eBGP/iBGP neighbor.
Step 8	<b>commit</b>	

### BGP Unequal Cost Recursive Load Balancing: Example

This is a sample configuration for unequal cost recursive load balancing:

```

interface Loopback0
  ipv4 address 20.20.20.20 255.255.255.255
!
interface MgmtEth0/RSP0/CPU0/0
  ipv4 address 8.43.0.10 255.255.255.0
!
interface TenGigE0/3/0/0
  bandwidth 8000000
  ipv4 address 11.11.11.11 255.255.255.0
  ipv6 address 11:11:0:1::11/64
!
interface TenGigE0/3/0/1
  bandwidth 7000000
  ipv4 address 11.11.12.11 255.255.255.0
  ipv6 address 11:11:0:2::11/64
!
interface TenGigE0/3/0/2
  bandwidth 6000000
  ipv4 address 11.11.13.11 255.255.255.0
  ipv6 address 11:11:0:3::11/64
!
interface TenGigE0/3/0/3
  bandwidth 5000000
  ipv4 address 11.11.14.11 255.255.255.0
  ipv6 address 11:11:0:4::11/64
!
interface TenGigE0/3/0/4
  bandwidth 4000000
  ipv4 address 11.11.15.11 255.255.255.0
  ipv6 address 11:11:0:5::11/64
!
interface TenGigE0/3/0/5
  bandwidth 3000000
  ipv4 address 11.11.16.11 255.255.255.0
  ipv6 address 11:11:0:6::11/64
!
interface TenGigE0/3/0/6
  bandwidth 2000000
  ipv4 address 11.11.17.11 255.255.255.0
  ipv6 address 11:11:0:7::11/64
!
interface TenGigE0/3/0/7
  bandwidth 1000000
  ipv4 address 11.11.18.11 255.255.255.0
  ipv6 address 11:11:0:8::11/64

```

```

!
interface TenGigE0/4/0/0
  description CONNECTED TO IXIA 1/3
  transceiver permit pid all
!
interface TenGigE0/4/0/2
  ipv4 address 9.9.9.9 255.255.0.0
  ipv6 address 9:9::9/64
  ipv6 enable
!
route-policy pass-all
  pass
end-policy
!
router static
  address-family ipv4 unicast
    202.153.144.0/24 8.43.0.1
!
!
router bgp 100
  bgp router-id 20.20.20.20
  address-family ipv4 unicast
    maximum-paths eibgp 8
    redistribute connected
!
neighbor 11.11.11.12
  remote-as 200
  dmz-link-bandwidth
  address-family ipv4 unicast
    route-policy pass-all in
    route-policy pass-all out
!
!
neighbor 11.11.12.12
  remote-as 200
  dmz-link-bandwidth
  address-family ipv4 unicast
    route-policy pass-all in
    route-policy pass-all out
!
!
neighbor 11.11.13.12
  remote-as 200
  dmz-link-bandwidth
  address-family ipv4 unicast
    route-policy pass-all in
    route-policy pass-all out
!
!
neighbor 11.11.14.12
  remote-as 200
  dmz-link-bandwidth
  address-family ipv4 unicast
    route-policy pass-all in
    route-policy pass-all out
!
!
neighbor 11.11.15.12
  remote-as 200
  dmz-link-bandwidth
  address-family ipv4 unicast
    route-policy pass-all in
    route-policy pass-all out
!

```



```
!  
neighbor 11.11.16.12  
  remote-as 200  
  dmz-link-bandwidth  
  address-family ipv4 unicast  
    route-policy pass-all in  
    route-policy pass-all out  
  !  
!  
neighbor 11.11.17.12  
  remote-as 200  
  dmz-link-bandwidth  
  address-family ipv4 unicast  
    route-policy pass-all in  
    route-policy pass-all out  
  !  
!  
neighbor 11.11.18.12  
  remote-as 200  
  dmz-link-bandwidth  
  address-family ipv4 unicast  
    route-policy pass-all in  
    route-policy pass-all out  
  !  
!  
!  
end
```

## Configuring BGP Large Communities

BGP communities provide a way to group destinations and apply routing decisions such as acceptance, rejection, preference, or redistribution on a group of destinations using community attributes. BGP community attributes are variable length attributes consisting of a set of one or more 4-byte values which are split into two parts of 16 bits. The higher-order 16 bits represents the AS number and the lower order bits represents a locally defined value assigned by the operator of the AS.

Since the adoption of 4-byte ASNs (RFC6793), the BGP communities attribute can no longer accommodate the 4 byte ASNs as you need more than 4 bytes to encode the 4-byte ASN and an AS specific value that you want to tag with the route. Although BGP extended community permits a 4-byte AS to be encoded as the global administrator field, the local administrator field has only 2-byte of available space. So, 6-byte extended community attribute is also unsuitable. To overcome this limitation, you can configure a 12-byte BGP large community which is an optional attribute that provides the most significant 4-byte value to encode autonomous system number as the global administrator and the remaining two 4-byte assigned numbers to encode the local values.

Similar to BGP communities, routers can apply BGP large communities to BGP routes by using route policy languages (RPL) and other routers can then perform actions based on the community that is attached to the route. The policy language provides sets as a container for groups of values for matching purposes.

When large communities are specified in other commands, they are specified as three non negative decimal integers separated by colons. For example, 1:2:3. Each integer is stored in 32 bits. The possible range for each integer is 0 to 4294967295.

In route-policy statements, each integer in the BGP large community can be replaced by any of the following expressions :

- [x..y] — This expression specifies a range between x and y, inclusive.

- \* —This expression stands for any number.
- peeras — This expression is replaced by the AS number of the neighbor from which the community is received or to which the community is sent, as appropriate.
- not-peeras —This expression matches any number other than the peeras.
- private-as — This expression specifies any number in the private ASN range: [64512..65534] and [4200000000..4294967294].

These expressions can be also used in policy-match statements.

IOS regular expression (ios-regex) and DFA style regular expression (dfa-regex) can be used in any of the large-community policy match and delete statements. For example, the IOS regular expression ios-regex '^5:.\*:7\$' is equivalent to the expression 5:\*.7.

The **send-community-ebgp** command is extended to include BGP large communities. This command is required for the BGP speaker to send large communities to ebgp neighbors.

### Restrictions and Guidelines

The following restrictions and guidelines apply for BGP large communities:

- All functionalities of the BGP community attribute is available for the BGP large-community attribute.
- The **send-community-ebgp** command is required for the BGP speaker to send large communities to ebgp neighbors.
- There are no well-known large-communities.
- The peeras expression cannot be used in a large-community-set.
- The peeras expression can only be used in large-community match or delete statements that appear in route policies that are applied at the neighbor-in or neighbor-out attach points.
- The not-peeras expression cannot be used in a large-community-set or in policy set statements.

### Configuration Example: Large Community Set

A large-community set defines a set of large communities. Named large-community sets are used in route-policy match and set statements.

This example shows how to create a named large-community set.

```
RP/0/RP0/CPU0:router(config)# large-community-set catbert
RP/0/RP0/CPU0:router(config-largecomm)# 1: 2: 3,
RP/0/RP0/CPU0:router(config-largecomm)# peeras:2:3
RP/0/RP0/CPU0:router(config-largecomm)# end-set
```

### Configuration Example: Set Large Community

The following example shows how to set the BGP large community attribute in a route, using the **set large-community** {*large-community-set-name* | *inline-large-community-set* | *parameter* } [**additive** ] command. You can specify a named large-community-set or an inline set. The **additive** keyword retains the large communities already present in the route and adds the new set of large communities. However the **additive** keyword does not result in duplicate entries.

If a particular large community is attached to a route and you specify the same large community again with the additive keyword in the set statement, then the specified large community is not added again. The merging operation removes duplicate entries. This also applies to the `peer-as` keyword.

The `peer-as` expression in the example is replaced by the AS number of the neighbor from which the BGP large community is received or to which the community is sent, as appropriate.

```
RP/0/RP0/CPU0:router(config)# route-policy mordac
RP/0/RP0/CPU0:router(config-rpl)# set large-community (1:2:3, peer-as:2:3)
RP/0/RP0/CPU0:router(config-rpl)# end-set
RP/0/RP0/CPU0:router(config)# large-community-set catbert
RP/0/RP0/CPU0:router(config-largecomm)# 1: 2: 3,
RP/0/RP0/CPU0:router(config-largecomm)# peer-as:2:3
RP/0/RP0/CPU0:router(config-largecomm)# end-set
RP/0/RP0/CPU0:router(config)# route-policy wally
RP/0/RP0/CPU0:router(config-rpl)# set large-community catbert additive
RP/0/RP0/CPU0:router(config-rpl)# end-set
```

In this example, if the route-policy `mordac` is applied to a neighbor, the ASN of which is 1, then the large community (1:2:3) is set only once.



---

**Note** You should configure the `send-community-ebgp` command to send large communities to ebgp neighbors.

---

### Configuration Example: Large Community Matches-any

The following example shows how to configure a route policy to match any element of a large -community set. This is a boolean condition and returns true if any of the large communities in the route match any of the large communities in the match condition.

```
RP/0/RP0/CPU0:router(config)# route-policy elbonia
RP/0/RP0/CPU0:router(config-rpl)# if large-community matches-any (1:2:3, 4:5:*) then
RP/0/RP0/CPU0:router(config-rpl)#   set local-preference 94
RP/0/RP0/CPU0:router(config-rpl)# endif
RP/0/RP0/CPU0:router(config-rpl)# end-policy
```

### Configuration Example: Large Community Matches-every

The following example shows how to configure a route policy where every match specification in the statement must be matched by at least one large community in the route.

```
RP/0/RP0/CPU0:router(config)# route-policy bob
RP/0/RP0/CPU0:router(config-rpl)# if large-community matches-every (*:3, 4:5:*) then
RP/0/RP0/CPU0:router(config-rpl)#   set local-preference 94
RP/0/RP0/CPU0:router(config-rpl)# endif
RP/0/RP0/CPU0:router(config-rpl)# end-policy
```

In this example, routes with these sets of large communities return TRUE:

- (1:1:3, 4:5:10)
- (4:5:3) —This single large community matches both specifications.
- (1:1:3, 4:5:10, 7:6:5)

Routes with the following set of large communities return FALSE:

(1:1:3, 5:5:10)—The specification (4:5:\*) is not matched.

### Configuration Example: Large Community Matches-within

The following example shows how to configure a route policy to match within a large community set. This is similar to the **large-community matches-any** command but every large community in the route must match at least one match specification. Note that if the route has no large communities, then it matches.

```
RP/0/RP0/CPU0:router(config)# route-policy bob
RP/0/RP0/CPU0:router(config-rpl)# if large-community matches-within (*:3, 4:5:*) then
RP/0/RP0/CPU0:router(config-rpl)#   set local-preference 103
RP/0/RP0/CPU0:router(config-rpl)# endif
RP/0/RP0/CPU0:router(config-rpl)# end-policy
```

For example, routes with these sets of large communities return TRUE:

- (1:1:3, 4:5:10)
- (4:5:3)
- (1:2:3, 6:6:3, 9:4:3)

Routes with this set of large communities return FALSE:

(1:1:3, 4:5:10, 7:6:5) —The large community (7:6:5) does not match

### Configuration Example: Community Matches-within

The following example shows how to configure a route policy to match within the elements of a community set. This command is similar to the **community matches-any** command, but every community in the route must match at least one match specification. If the route has no communities, then it matches.

```
RP/0/RP0/CPU0:router(config)# route-policy bob
RP/0/RP0/CPU0:router(config-rpl)# if community matches-within (*:3, 5:*) then
RP/0/RP0/CPU0:router(config-rpl)#   set local-preference 94
RP/0/RP0/CPU0:router(config-rpl)# endif
RP/0/RP0/CPU0:router(config-rpl)# end-policy
```

For example, routes with these sets of communities return TRUE:

- (1:3, 5:10)
- (5:3)
- (2:3, 6:3, 4:3)

Routes with this set of communities return FALSE:

(1:3, 5:10, 6:5) —The community (6:5) does not match.

### Configuration Example: Large Community Is-empty

The following example shows using the **large-community is-empty** clause to filter routes that do not have the large-community attribute set.

```
RP/0/RP0/CPU0:router(config)# route-policy lrg_comm_rp4
RP/0/RP0/CPU0:router(config-rpl)# if large-community is-empty then
RP/0/RP0/CPU0:router(config-rpl)#   set local-preference 104
RP/0/RP0/CPU0:router(config-rpl)# endif
RP/0/RP0/CPU0:router(config-rpl)# end-policy
```

### Configuration Example: Attribute Filter Group

The following example shows how to configure and apply the attribute-filter group with large-community attributes for a BGP neighbor. The filter specifies the BGP path attributes and an action to take when BGP update message is received. If an update message is received from the BGP neighbor that contains any of the specified attributes, then the specified action is taken. In this example, the attribute filter named dogbert is created and applied to the BGP neighbor 10.0.1.101. It specifies the large community attribute and the action of discard. That means, if the large community BGP path attribute is received in a BGP UPDATE message from the neighbor 10.0.1.101 then the attribute will be discarded before further processing of the message.

```
RP/0/RP0/CPU0:router(config)# router bgp 100
RP/0/RP0/CPU0:router(config-bgp)# attribute-filter group dogbert
RP/0/RP0/CPU0:router(config-bgp-attrfg)# attribute LARGE-COMMUNITY discard
RP/0/RP0/CPU0:router(config-bgp-attrfg)# neighbor 10.0.1.101
RP/0/RP0/CPU0:router(config-bgp-nbr)# remote-as 6461
RP/0/RP0/CPU0:router(config-bgp-nbr)# update in filtering
RP/0/RP0/CPU0:router(config-nbr-upd-filter)# attribute-filter group dogbert
```

### Configuration Example: Deleting Large Community

The following example shows how to delete specified BGP large-communities from a route policy using the **delete large-community** command.

```
RP/0/RP0/CPU0:router(config)# route-policy lrg_comm_rp2
RP/0/RP0/CPU0:router(config-rpl)# delete large-community in (ios-regex '^100000:')
RP/0/RP0/CPU0:router(config-rpl)# delete large-community all
RP/0/RP0/CPU0:router(config-rpl)# delete large-community not in (peeras:*:*, 41289:*:*)
```

### Verification

This example displays the routes with large-communities given in the **show bgp large-community list-of-large-communities [exact-match ]** command. If the optional keyword exact-match is used, then the listed routes will contain only the specified large communities. Otherwise, the displayed routes may contain additional large communities.

```
RP/0/0/CPU0:R1# show bgp large-community 1:2:3 5:6:7
Thu Mar 23 14:40:33.597 PDT
BGP router identifier 4.4.4.4, local AS number 3
BGP generic scan interval 60 secs
Non-stop routing is enabled
BGP table state: Active
Table ID: 0xe0000000 RD version: 66
BGP main routing table version 66
BGP NSR Initial initsync version 3 (Reached)
BGP NSR/ISSU Sync-Group versions 66/0
BGP scan interval 60 secs

Status codes: s suppressed, d damped, h history, * valid, > best
               i - internal, r RIB-failure, S stale, N Nexthop-discard
Origin codes: i - IGP, e - EGP, ? - incomplete
   Network        Next Hop           Metric LocPrf Weight Path
* 10.0.0.3/32     10.10.10.3         0      94      0 ?
* 10.0.0.5/32     10.11.11.5         0              0 5 ?
```

This example displays the large community attached to a network using the **show bgp ip-address/prefix-length** command.

```

RP/0/0/CPU0:R4# show bgp 10.3.3.3/32
Thu Mar 23 14:36:15.301 PDT
BGP routing table entry for 10.3.3.3/32
Versions:
  Process          bRIB/RIB  SendTblVer
  Speaker          42        42
Last Modified: Mar 22 20:04:46.000 for 18:31:30
Paths: (1 available, best #1)
  Advertised to peers (in unique update groups):
    10.11.11.5
  Path #1: Received by speaker 0
  Advertised to peers (in unique update groups):
    10.11.11.5
Local
  10.10.10.3 from 10.10.10.3 (10.3.3.3)
  Origin incomplete, metric 0, localpref 94, valid, internal, best, group-best
  Received Path ID 0, Local Path ID 0, version 42
  Community: 258:259 260:261 262:263 264:265
  Large Community: 1:2:3 5:6:7 4123456789:4123456780:4123456788

```

## Enabling BGP: Example

The following shows how to enable BGP.

```

prefix-set static
  2020::/64,
  2012::/64,
  10.10.0.0/16,
  10.2.0.0/24
end-set

route-policy pass-all
  pass
end-policy
route-policy set_next_hop_agg_v4
  set next-hop 10.0.0.1
end-policy

route-policy set_next_hop_static_v4
  if (destination in static) then
    set next-hop 10.1.0.1
  else
    drop
  endif
end-policy

route-policy set_next_hop_agg_v6
  set next-hop 2003::121
end-policy

route-policy set_next_hop_static_v6
  if (destination in static) then
    set next-hop 2011::121
  else
    drop
  endif
end-policy

router bgp 65000
  bgp fast-external-fallover disable
  bgp confederation peers

```

```
65001
65002
bgp confederation identifier 1
bgp router-id 1.1.1.1
address-family ipv4 unicast
  aggregate-address 10.2.0.0/24 route-policy set_next_hop_agg_v4
  aggregate-address 10.3.0.0/24
  redistribute static route-policy set_next_hop_static_v4

address-family ipv6 unicast
  aggregate-address 2012::/64 route-policy set_next_hop_agg_v6
  aggregate-address 2013::/64
  redistribute static route-policy set_next_hop_static_v6

neighbor 10.0.101.60
  remote-as 65000
  address-family ipv4 unicast

neighbor 10.0.101.61
  remote-as 65000
  address-family ipv4 unicast

neighbor 10.0.101.62
  remote-as 3
  address-family ipv4 unicast
  route-policy pass-all in
  route-policy pass-all out

neighbor 10.0.101.64
  remote-as 5
  update-source Loopback0
  address-family ipv4 unicast
  route-policy pass-all in
  route-policy pass-all out
```

## Displaying BGP Update Groups: Example

The following is sample output from the `show bgp update-group`:

### `show bgp update-group`

```
Update group for IPv4 Unicast, index 0.1:
  Attributes:
    Outbound Route map:rm
    Minimum advertisement interval:30
  Messages formatted:2, replicated:2
  Neighbors in this update group:
    10.0.101.92

Update group for IPv4 Unicast, index 0.2:
  Attributes:
    Minimum advertisement interval:30
  Messages formatted:2, replicated:2
  Neighbors in this update group:
    10.0.101.91
```

## BGP Neighbor Configuration: Example

The following example shows how BGP neighbors on an autonomous system are configured to share information. In the example, a BGP router is assigned to autonomous system 109, and two networks are listed as originating in the autonomous system. Then the addresses of three remote routers (and their autonomous systems) are listed. The router being configured shares information about networks 172.16.0.0 and 192.168.7.0 with the neighbor routers. The first router listed is in a different autonomous system; the second **neighbor** and **remote-as** commands specify an internal neighbor (with the same autonomous system number) at address 172.26.234.2; and the third **neighbor** and **remote-as** commands specify a neighbor on a different autonomous system.

```
route-policy pass-all
  pass
end-policy
router bgp 109
  address-family ipv4 unicast
    network 172.16.0.0 255.255.0.0
    network 192.168.7.0 255.255.0.0
    neighbor 172.16.200.1
      remote-as 167
    exit
  address-family ipv4 unicast
    route-policy pass-all in
    route-policy pass-out out
    neighbor 172.26.234.2
      remote-as 109
    exit
  address-family ipv4 unicast
    neighbor 172.26.64.19
      remote-as 99
    exit
  address-family ipv4 unicast
    route-policy pass-all in
    route-policy pass-all out
```

## BGP Confederation: Example

The following is a sample configuration that shows several peers in a confederation. The confederation consists of three internal autonomous systems with autonomous system numbers 6001, 6002, and 6003. To the BGP speakers outside the confederation, the confederation looks like a normal autonomous system with autonomous system number 666 (specified using the **bgp confederation identifier** command).

In a BGP speaker in autonomous system 6001, the **bgp confederation peers** command marks the peers from autonomous systems 6002 and 6003 as special eBGP peers. Hence, peers 171.16.232.55 and 171.16.232.56 get the local preference, next hop, and MED unmodified in the updates. The router at 171.19.69.1 is a normal eBGP speaker, and the updates received by it from this peer are just like a normal eBGP update from a peer in autonomous system 666.

```
router bgp 6001
  bgp confederation identifier 666
  bgp confederation peers
    6002
    6003
```



```
    exit
address-family ipv4 unicast
neighbor 171.16.232.55
remote-as 6002
    exit
address-family ipv4 unicast
neighbor 171.16.232.56
remote-as 6003
    exit
address-family ipv4 unicast
neighbor 171.19.69.1
remote-as 777
```

In a BGP speaker in autonomous system 6002, the peers from autonomous systems 6001 and 6003 are configured as special eBGP peers. Peer 171.17.70.1 is a normal iBGP peer, and peer 199.99.99.2 is a normal eBGP peer from autonomous system 700.

```
router bgp 6002
  bgp confederation identifier 666
  bgp confederation peers
    6001
    6003
  exit
address-family ipv4 unicast
neighbor 171.17.70.1
remote-as 6002
  exit
address-family ipv4 unicast
neighbor 171.19.232.57
remote-as 6001
  exit
address-family ipv4 unicast
neighbor 171.19.232.56
remote-as 6003
  exit
address-family ipv4 unicast
neighbor 171.19.99.2
remote-as 700
  exit
address-family ipv4 unicast
route-policy pass-all in
route-policy pass-all out
```

In a BGP speaker in autonomous system 6003, the peers from autonomous systems 6001 and 6002 are configured as special eBGP peers. Peer 192.168.200.200 is a normal eBGP peer from autonomous system 701.

```
router bgp 6003
  bgp confederation identifier 666
  bgp confederation peers
    6001
    6002
  exit
address-family ipv4 unicast
neighbor 171.19.232.57
remote-as 6001
  exit
address-family ipv4 unicast
```

```

neighbor 171.19.232.55
  remote-as 6002
  exit
address-family ipv4 unicast
  neighbor 192.168.200.200
  remote-as 701
  exit
address-family ipv4 unicast
  route-policy pass-all in
  route-policy pass-all out

```

The following is a part of the configuration from the BGP speaker 192.168.200.205 from autonomous system 701 in the same example. Neighbor 171.16.232.56 is configured as a normal eBGP speaker from autonomous system 666. The internal division of the autonomous system into multiple autonomous systems is not known to the peers external to the confederation.

```

router bgp 701
  address-family ipv4 unicast
  neighbor 172.16.232.56
  remote-as 666
  exit
  address-family ipv4 unicast
  route-policy pass-all in
  route-policy pass-all out
  exit
  address-family ipv4 unicast
  neighbor 192.168.200.205
  remote-as 701

```

## BGP Route Reflector: Example

The following example shows how to use an address family to configure internal BGP peer 10.1.1.1 as a route reflector client:

```

router bgp 140
  address-family ipv4 unicast
  neighbor 10.1.1.1
  remote-as 140
  address-family ipv4 unicast
  route-reflector-client
  exit

```

## BGP Route Reflector: Example

The following example shows how to use an address family to configure internal BGP peer 10.1.1.1 as a route reflector client:

```

router bgp 140
  address-family ipv4 unicast
  neighbor 10.1.1.1

```

```
remote-as 140
address-family ipv4 unicast
route-reflector-client
exit
```

## BGP MDT Address Family Configuration: Example

The following example shows how to configure an MDT address family in BGP:

```
router bgp 10

  bgp router-id 10.0.0.2
  address-family ipv4 unicast
  address-family vpnv4 unicast
  address-family ipv4 mdt

  !
  neighbor 1.1.1.1

  remote-as 11
  update-source Loopback0
  address-family ipv4 unicast
  address-family vpnv4 unicast
  address-family ipv4 md

  !
```

## BGP Nonstop Routing Configuration: Example

The following example shows how to enable BGP NSR:

```
configure
router bgp 120
nsr
end
```

The following example shows how to disable BGP NSR:

```
configure
router bgp 120
no nsr
end
```

## Best-External Path Advertisement Configuration: Example

The following example shows how to configure Best-External Path Advertisement:

```
router bgp 100
  address-family l2vpn vpls-vpws
  advertise best-external
end
```

## Primary Backup Path Installation: Example

The following example shows how to enable installation of primary backup path:

```
router bgp 100
  address-family l2vpn vpls-vpws
  additional-paths install backup
end
```

## iBGP Multipath Loadsharing Configuration: Example

The following is a sample configuration where 30 paths are used for loadsharing:

```
router bgp 100
  address-family ipv4 multicast
  maximum-paths ibgp 30
  !
  !
end
```

## Discard Extra Paths Configuration: Example

The following example shows how to configure discard extra paths feature for the IPv4 address family:

```
RP/0/RSP0/CPU0:router# configure
RP/0/RSP0/CPU0:router(config)# router bgp 10
RP/0/RSP0/CPU0:router(config-bgp)# neighbor 10.0.0.1
RP/0/RSP0/CPU0:router(config-bgp-nbr)# address-family ipv4 unicast
RP/0/RSP0/CPU0:router(config-bgp-nbr-af)# maximum-prefix 1000 discard-extra-paths
RP/0/RSP0/CPU0:router(config-bgp-vrf-af)# commit
```

## Verify Per Neighbor TCP MSS: Examples

The following example shows how to verify the per neighbor TCP MSS feature on a router:

The **show bgp neighbor** output shows the cumulative number for the *Prefix advertised* count if the same prefixes are withdrawn and re-advertised.

```
Router#show bgp neighbor 10.0.0.2

BGP neighbor is 10.0.0.2
```

```

Remote AS 1, local AS 1, internal link
Remote router ID 10.0.0.2
BGP state = Established, up for 00:09:17
Last read 00:00:16, Last read before reset 00:00:00
Hold time is 180, keepalive interval is 60 seconds
Configured hold time: 180, keepalive: 60, min acceptable hold time: 3
Last write 00:00:16, attempted 19, written 19
Second last write 00:01:16, attempted 19, written 19
Last write before reset 00:00:00, attempted 0, written 0
Second last write before reset 00:00:00, attempted 0, written 0
Last write pulse rcvd Dec 7 11:58:42.411 last full not set pulse count 23
Last write pulse rcvd before reset 00:00:00
Socket not armed for io, armed for read, armed for write
Last write thread event before reset 00:00:00, second last 00:00:00
Last KA expiry before reset 00:00:00, second last 00:00:00
Last KA error before reset 00:00:00, KA not sent 00:00:00
Last KA start before reset 00:00:00, second last 00:00:00
Precedence: internet
Multi-protocol capability received
Neighbor capabilities:
Route refresh: advertised (old + new) and received (old + new)
Graceful Restart (GR Awareness): advertised and received
4-byte AS: advertised and received
Address family IPv4 Unicast: advertised and received
Received 12 messages, 0 notifications, 0 in queue
Sent 12 messages, 0 notifications, 0 in queue
Minimum time between advertisement runs is 0 secs
TCP Maximum Segment Size 500

For Address Family: IPv4 Unicast
BGP neighbor version 4
Update group: 0.2 Filter-group: 0.1 No Refresh request being processed
Route refresh request: received 0, sent 0
0 accepted prefixes, 0 are bestpaths
Cumulative no. of prefixes denied: 0.
Prefix advertised 0, suppressed 0, withdrawn 0
Maximum prefixes allowed 1048576
Threshold for warning message 75%, restart interval 0 min
AIGP is enabled
An EoR was received during read-only mode
Last ack version 4, Last synced ack version 0
Outstanding version objects: current 0, max 0
Additional-paths operation: None
Send Multicast Attributes

```

The following example shows how to verify the TCP MSS configuration:

```

RP/0/0/CPU0:ios#show bgp neighbor 10.0.0.2 configuration

neighbor 10.0.0.2
remote-as 1 []
tcp-mss 400 [n:n1]
address-family IPv4 Unicast []

```

The following example shows how to display TCP connection endpoints information:

```

RP/0/0/CPU0:ios#show tcp brief

```

PCB	VRF-ID	Recv-Q	Send-Q	Local Address	Foreign Address	State
0x08789b28	0x60000000	0	0	:::179	:::0	LISTEN
0x08786160	0x00000000	0	0	:::179	:::0	LISTEN

```

0xecb0c9f8 0x60000000 0 0 10.0.0.1:12404 10.0.0.2:179 ESTAB
0x0878b168 0x60000000 0 0 11.0.0.1:179 11.0.0.2:61177 ESTAB
0xecb0c6b8 0x60000000 0 0 0.0.0.0:179 0.0.0.0:0 LISTEN
0x08781590 0x00000000 0 0 0.0.0.0:179 0.0.0.0:0 LISTEN

```

The following example shows how to display TCP connection information for a specific PCB value:

```

RP/0/0/CPU0:ios#show tcp pcb 0xecb0c9f8

Connection state is ESTAB, I/O status: 0, socket status: 0
Established at Sun Dec 7 11:49:39 2014

PCB 0xecb0c9f8, SO 0xecb01b68, TCPCB 0xecb01d78, vrfid 0x60000000,
Pak Prio: Medium, TOS: 192, TTL: 255, Hash index: 1322
Local host: 10.0.0.1, Local port: 12404 (Local App PID: 19840)
Foreign host: 10.0.0.2, Foreign port: 179

Current send queue size in bytes: 0 (max 24576)
Current receive queue size in bytes: 0 (max 32768) mis-ordered: 0 bytes
Current receive queue size in packets: 0 (max 0)

Timer Starts Wakeups Next(msec)
Retrans 17 2 0
SendWnd 0 0 0
TimeWait 0 0 0
AckHold 13 5 0
KeepAlive 1 0 0
PmtuAger 0 0 0
GiveUp 0 0 0
Throttle 0 0 0

iss: 1728179225 snduna: 1728179536 sndnxt: 1728179536
sndmax: 1728179536 sndwnd: 32517 sndcwnd: 1000
irs: 2055835995 rcvnxt: 2055836306 rcvwnd: 32536 rcvadv: 2055868842

SRTT: 206 ms, RTTO: 300 ms, RTV: 59 ms, KRTT: 0 ms
minRTT: 10 ms, maxRTT: 230 ms

ACK hold time: 200 ms, Keepalive time: 0 sec, SYN waittime: 30 sec
Giveup time: 0 ms, Retransmission retries: 0, Retransmit forever: FALSE
Connect retries remaining: 30, connect retry interval: 30 secs

State flags: none
Feature flags: Win Scale, Nagle
Request flags: Win Scale

Datagrams (in bytes): MSS 500, peer MSS 1460, min MSS 500, max MSS 1460

Window scales: rcv 0, snd 0, request rcv 0, request snd 0
Timestamp option: recent 0, recent age 0, last ACK sent 0
Sack blocks {start, end}: none
Sack holes {start, end, dups, rxmit}: none

Socket options: SO_REUSEADDR, SO_REUSEPORT, SO_NBIO
Socket states: SS_ISCONNECTED, SS_PRIV
Socket receive buffer states: SB_DEL_WAKEUP
Socket send buffer states: SB_DEL_WAKEUP
Socket receive buffer: Low/High watermark 1/32768
Socket send buffer : Low/High watermark 2048/24576, Notify threshold 0

PDU information:
#PDU's in buffer: 0
FIB Lookup Cache: IFH: 0x200 PD ctx: size: 0 data:

```

Num Labels: 0 Label Stack:

## Originating Prefixes With AiGP: Example

The following is a sample configuration for originating prefixes with the AiGP metric attribute:

```
route-policy aigp-policy
  set aigp-metric 4
  set aigp-metric igp-cost
end-policy
!
router bgp 100
  address-family ipv4 unicast
    network 10.2.3.4/24 route-policy aigp-policy
    redistribute ospf osp1 metric 4 route-policy aigp-policy
  !
  !
end
```

## BGP Accept Own Configuration: Example

This example shows how to configure BGP Accept Own on a PE router.

```
router bgp 100
  neighbor 45.1.1.1
    remote-as 100
    update-source Loopback0
    address-family vpnv4 unicast
      route-policy pass-all in
      accept-own
      route-policy drop_111.x.x.x out
    !
    address-family vpnv6 unicast
      route-policy pass-all in
      accept-own
      route-policy drop_111.x.x.x out
    !
  !
```

This example shows an InterAS-RR configuration for BGP Accept Own.

```
router bgp 100
  neighbor 45.1.1.1
    remote-as 100
    update-source Loopback0
    address-family vpnv4 unicast
      route-policy rt_stitch1 in
      route-reflector-client
      route-policy add_bgp_ao out
    !
    address-family vpnv6 unicast
      route-policy rt_stitch1 in
      route-reflector-client
      route-policy add_bgp_ao out
    !
  !
  extcommunity-set rt cs_100:1
```

```

    100:1
end-set
!
extcommunity-set rt cs_1001:1
    1001:1
end-set
!
route-policy rt_stitch1
    if extcommunity rt matches-any cs_100:1 then
        set extcommunity rt cs_1000:1 additive
    endif
end-policy
!
route-policy add_bgp_ao
    set community (accept-own) additive
end-policy
!

```

## BGP Unequal Cost Recursive Load Balancing: Example

This is a sample configuration for unequal cost recursive load balancing:

```

interface Loopback0
    ipv4 address 20.20.20.20 255.255.255.255
!
!
interface FourHundredGige0/1/0/0
    bandwidth 8000000
    ipv4 address 11.11.11.11 255.255.255.0
    ipv6 address 11:11:0:1::11/64
!
interface FourHundredGige0/0/0/0
    bandwidth 7000000
    ipv4 address 11.11.12.11 255.255.255.0
    ipv6 address 11:11:0:2::11/64
!
interface FourHundredGige0/3/0/0
    bandwidth 6000000
    ipv4 address 11.11.13.11 255.255.255.0
    ipv6 address 11:11:0:3::11/64
!
interface FourHundredGige0/4/0/0
    bandwidth 5000000
    ipv4 address 11.11.14.11 255.255.255.0
    ipv6 address 11:11:0:4::11/64
!
interface FourHundredGige0/0/0/0
    bandwidth 4000000
    ipv4 address 11.11.15.11 255.255.255.0
    ipv6 address 11:11:0:5::11/64
!
interface FourHundredGige0/2/0/0
    bandwidth 3000000
    ipv4 address 11.11.16.11 255.255.255.0
    ipv6 address 11:11:0:6::11/64
!
interface FourHundredGige0/3/0/0
    bandwidth 2000000
    ipv4 address 11.11.17.11 255.255.255.0
    ipv6 address 11:11:0:7::11/64

```



```
!  
interface FourHundredGige0/3/0/0  
  bandwidth 1000000  
  ipv4 address 11.11.18.11 255.255.255.0  
  ipv6 address 11:11:0:8::11/64  
!  
interface FourHundredGige0/4/0/0  
  description CONNECTED TO IXIA 1/3  
  transceiver permit pid all  
!  
interface FourHundredGige0/4/0/0  
  ipv4 address 9.9.9.9 255.255.0.0  
  ipv6 address 9:9::9/64  
  ipv6 enable  
!  
route-policy pass-all  
  pass  
end-policy  
!  
router static  
  address-family ipv4 unicast  
    202.153.144.0/24 8.43.0.1  
  !  
!  
router bgp 100  
  bgp router-id 10.20.20.20  
  address-family ipv4 unicast  
    maximum-paths eibgp 8  
    redistribute connected  
  !  
  neighbor 11.11.11.12  
    remote-as 200  
    dmz-link-bandwidth  
    address-family ipv4 unicast  
      route-policy pass-all in  
      route-policy pass-all out  
    !  
  !  
  neighbor 11.11.12.12  
    remote-as 200  
    dmz-link-bandwidth  
    address-family ipv4 unicast  
      route-policy pass-all in  
      route-policy pass-all out  
    !  
  !  
  neighbor 10.11.13.12  
    remote-as 200  
    dmz-link-bandwidth  
    address-family ipv4 unicast  
      route-policy pass-all in  
      route-policy pass-all out  
    !  
  !  
  neighbor 11.11.14.12  
    remote-as 200  
    dmz-link-bandwidth  
    address-family ipv4 unicast  
      route-policy pass-all in  
      route-policy pass-all out  
    !  
  !  
  neighbor 11.11.15.12  
    remote-as 200
```

```

dmz-link-bandwidth
address-family ipv4 unicast
  route-policy pass-all in
  route-policy pass-all out
!
!
neighbor 11.11.16.12
  remote-as 200
  dmz-link-bandwidth
  address-family ipv4 unicast
    route-policy pass-all in
    route-policy pass-all out
  !
!
neighbor 11.11.17.12
  remote-as 200
  dmz-link-bandwidth
  address-family ipv4 unicast
    route-policy pass-all in
    route-policy pass-all out
  !
!
neighbor 11.11.18.12
  remote-as 200
  dmz-link-bandwidth
  address-family ipv4 unicast
    route-policy pass-all in
    route-policy pass-all out
  !
!
end

```

## Flow-tag propagation

The flow-tag propagation feature enables you to establish a co-relation between route-policies and user-policies. Flow-tag propagation using BGP allows user-side traffic-steering based on routing attributes such as, AS number, prefix lists, community strings and extended communities. Flow-tag is a logical numeric identifier that is distributed through RIB as one of the routing attribute of FIB entry in the FIB lookup table. A flow-tag is instantiated using the 'set' operation from RPL and is referenced in the C3PL PBR policy, where it is associated with actions (policy-rules) against the flow-tag value.

You can use flow-tag propagation to:

- Classify traffic based on destination IP addresses (using the Community number) or based on prefixes (using Community number or AS number).
- Select a TE-group that matches the cost of the path to reach a service-edge based on customer site service level agreements (SLA).
- Apply traffic policy (TE-group selection) for specific customers based on SLA with its clients.
- Divert traffic to application or cache server.

## Restrictions for Flow-Tag Propagation

Some restrictions are placed with regard to using Quality-of-service Policy Propagation Using Border Gateway Protocol (QPPB) and flow-tag feature together. These include:

- A route-policy can have either 'set qos-group' or 'set flow-tag,' but not both for a prefix-set.
- Route policy for qos-group and route policy flow-tag cannot have overlapping routes. The QPPB and flow tag features can coexist (on same as well as on different interfaces) as long as the route policy used by them do not have any overlapping route.
- Mixing usage of qos-group and flow-tag in route-policy and policy-map is not recommended.

## Configuring Destination-Based Flow-Tag Propagation

The destination-based flow tag feature allows you to match packets based on the flow-tag assigned to the destination address of the incoming packets. Once matched, you can then apply any supported PBR action on this policy.



---

**Note** You will not be able to enable both QPPB and flow tag features simultaneously on an interface.

---

### Configuration

Use the following sample configuration to configure destination-based flow-tag propagation.

```

/* Configure a route policy for flow-tag propagation */
Router(config)# prefix-set FLOWTAG36
Router(config-pfx)# 10.1.30.0/24
Router(config-pfx)# end-set
Router(config)# prefix-set FLOWTAG38
Router(config-pfx)# 10.1.40.0/24
Router(config-pfx)# end-set

Router(config)# route-policy SETFLOWTAG
Router(config-rpl)# if destination in FLOWTAG36 then set flow-tag 36 endif
Router(config-rpl)# if destination in FLOWTAG38 then set flow-tag 38 endif
Router(config-rpl)# end-policy
Router(config)# commit
Tue Apr  3 15:10:07.223 IST

/* Configure the class map and policy map for flow-tag propagation */
Router(config)# class-map type traffic match-any FLOWMATCH36
Router(config-cmap)# match flow-tag 36
Router(config-cmap)# end-class-map

Router(config)# class-map type traffic match-any FLOWMATCH38
Router(config-cmap)# match flow-tag 38
Router(config-cmap)# end-class-map

Router(config)# policy-map type pbr FLOWMATCH
Router(config-pmap)# class type traffic FLOWMATCH36
Router(config-pmap-c)# redirect ipv4 nexthop 20.20.20.1
Router(config-pmap-c)# exit

```

```

Router(config-pmap)# class type traffic FLOWMATCH38
Router(config-pmap-c)# drop
Router(config-pmap-c)# exit
Router(config-pmap)# class type traffic DEFAULT
Router(config-pmap-c)# exit
Router(config-pmap)# end-policy-map

/* Configure BGP with flow-tag propagation */
Router(config)# router bgp 10
Router(config-bgp)# bgp router-id 1.1.1.1
Router(config-bgp)# address-family ipv4 unicast
Router(config-bgp-af)# table-policy SETFLOWTAG
Router(config-bgp-af)# redistribute static
Router(config-bgp-af)# bgp attribute-download
Router(config-bgp-af)# redistribute connected
Router(config-bgp-af)# exit

Router(config-bgp)# neighbor 20.20.20.1/24
Router(config-bgp-nbr)# remote-as 20
Router(config-bgp-nbr)# address-family ipv4 unicast
Router(config-bgp-nbr-af)# route-policy BGPIN in
Router(config-bgp-nbr-af)# route-policy BGPOUT out
Router(config-bgp-nbr-af)# exit
Router(config-bgp-nbr)# exit
Router(config-bgp)# exit

Router(config)# route-policy BGPIN
Router(config-rpl)# pass
Router(config-rpl)# end-policy
Router(config)# route-policy BGPOUT
Router(config-rpl)# pass
Router(config-rpl)# end-policy

/* Enter the interface configuration mode and enable flow tag on an interface. */
Router(config)# interface FourHundredGige 0/0/0/0
Router(config-if)# ipv4 address 10.10.10.1 255.255.255.0
Router(config-if)# service-policy type pbr input FLOWMATCH
Router(config-if)# no shut

/* Commit the configuration */
Router(config-if)# commit
Mon Mar 19 07:59:01.081 IST
RP/0/0/CPU0:Mar 19 07:59:01.537 : ifmgr[403]: %PKT_INFRA-LINK-3-UPDOWN : Interface
FourHundredGige0/1/0/0, changed state to Down
RP/0/0/CPU0:Mar 19 07:59:01.619 : ifmgr[403]: %PKT_INFRA-LINK-3-UPDOWN : Interface
FourHundredGige0/2/0/0, changed state to Up

/* Validate the configuraton */
Router(config)# do show run
Mon Mar 19 08:03:31.106 IST
Building configuration...
!! IOS XR Configuration 0.0.0
!! Last configuration change at Mon Mar 19 08:02:55 2018 by UNKNOWN
...
class-map type traffic match-any FLOWMATCH36
match flow-tag 36
end-class-map
!
!
class-map type traffic match-any FLOWMATCH40
match flow-tag 40
end-class-map
!

```

```
policy-map type pbr FLOWMATCH
  class type traffic FLOWMATCH36
    transmit
  !
  class type traffic FLOWMATCH40
    transmit
  !
  class type traffic class-default
  !
end-policy-map
!
interface FourHundredGige0/1/0/0
  ipv4 forwarding-enable
  ipv6 address 2000::2/64
!
interface FourHundredGige0/2/0/0
  service-policy type pbr input FLOWMATCH
  ipv4 address 10.10.10.1 255.255.255.0
!
interface FourHundredGige0/3/0/0
  ipv4 forwarding-enable
  ipv6 address 3000::2/64
!
...
!
prefix-set FLOWTAG36
  10.1.30.0/24
end-set
!
prefix-set FLOWTAG40
  10.1.40.0/24
end-set
!
route-policy SETFLOWTAG
  if destination in FLOWTAG36 then
    set flow-tag 36
  endif
  if destination in FLOWTAG40 then
    set flow-tag 40
  endif
end-policy
!
!
router bgp 10
  bgp router-id 1.1.1.1
  address-family ipv4 unicast
  table-policy SETFLOWTAG
  redistribute static
  bgp attribute-download
  redistribute connected
!
neighbor 20.20.20.1/24
  remote-as 20
  address-family ipv4 unicast
  route-policy BGPIN in
  route-policy BGPOUT out
!
route-policy BGPIN
  pass
end-policy
route-policy BGPOUT
  pass
end-policy
```

!

You have successfully configured destination-based flow-tag propagation.

## Configure Software to Store Updates from Neighbor

Perform this task to configure the software to store updates received from a neighbor.

The **soft-reconfiguration inbound** command causes a route refresh request to be sent to the neighbor if the neighbor is route refresh capable. If the neighbor is not route refresh capable, the neighbor must be reset to relearn received routes using the **clear bgp soft** command.



**Note** Storing updates from a neighbor works only if either the neighbor is route refresh capable or the **soft-reconfiguration inbound** command is configured. Even if the neighbor is route refresh capable and the **soft-reconfiguration inbound** command is configured, the original routes are not stored unless the **always** option is used with the command. The original routes can be easily retrieved with a route refresh request. Route refresh sends a request to the peer to resend its routing information. The **soft-reconfiguration inbound** command stores all paths received from the peer in an unmodified form and refers to these stored paths during the clear. Soft reconfiguration is memory intensive.

### SUMMARY STEPS

1. **configure**
2. **router bgp** *as-number*
3. **neighbor** *ip-address*
4. **address-family** { **ipv4** | **ipv6** } **unicast**
5. **soft-reconfiguration inbound** [ **always**]
6. Use the **commit** or **end** command.

### DETAILED STEPS

#### Step 1 **configure**

**Example:**

```
RP/0/# configure
```

Enters mode.

#### Step 2 **router bgp** *as-number*

**Example:**

```
Router(config)# router bgp 120
```

Specifies the autonomous system number and enters the BGP configuration mode, allowing you to configure the BGP routing process.

#### Step 3 **neighbor** *ip-address*

**Example:**

```
Router(config-bgp)# neighbor 172.168.40.24
```

Places the router in neighbor configuration mode for BGP routing and configures the neighbor IP address as a BGP peer.

**Step 4** **address-family { ipv4 | ipv6 } unicast****Example:**

```
Router(config-bgp-nbr)# address-family ipv4 unicast
```

Specifies either an IPv4 or IPv6 address family unicast and enters address family configuration submode.

To see a list of all the possible keywords and arguments for this command, use the CLI help (?).

**Step 5** **soft-reconfiguration inbound [ always]****Example:**

```
Router(config-bgp-nbr-af)# soft-reconfiguration inbound always
```

Configures the software to store updates received from a specified neighbor. Soft reconfiguration inbound causes the software to store the original unmodified route in addition to a route that is modified or filtered. This allows a “soft clear” to be performed after the inbound policy is changed.

Soft reconfiguration enables the software to store the incoming updates before apply policy if route refresh is not supported by the peer (otherwise a copy of the update is not stored). The **always** keyword forces the software to store a copy even when route refresh is supported by the peer.

**Step 6** Use the **commit** or **end** command.

**commit** —Saves the configuration changes and remains within the configuration session.

**end** —Prompts user to take one of these actions:

- **Yes** — Saves configuration changes and exits the configuration session.
- **No** —Exits the configuration session without committing the configuration changes.
- **Cancel** —Remains in the configuration session, without committing the configuration changes.

## Configuring BGP Route Dampening

Perform this task to configure and monitor BGP route dampening.

### SUMMARY STEPS

1. **configure**
2. **router bgp** *as-number*
3. **address-family { ipv4 | ipv6 } unicast**
4. **bgp dampening** [ *half-life* [ *reuse suppress max-suppress-time* ] ] | **route-policy** *route-policy-name* ]
5. Use the **commit** or **end** command.

## DETAILED STEPS

---

### Step 1 **configure**

#### Example:

```
RP/0/# configure
```

Enters mode.

### Step 2 **router bgp** *as-number*

#### Example:

```
Router(config)# router bgp 120
```

Specifies the autonomous system number and enters the BGP configuration mode, allowing you to configure the BGP routing process.

### Step 3 **address-family** { **ipv4** | **ipv6** } **unicast**

#### Example:

```
Router(config-bgp)# address-family ipv4 unicast
```

Specifies either the IPv4 or IPv6 address family and enters address family configuration submode.

To see a list of all the possible keywords and arguments for this command, use the CLI help (?).

### Step 4 **bgp dampening** [ *half-life* [ *reuse suppress max-suppress-time* ] | **route-policy** *route-policy-name* ]

#### Example:

```
Router(config-bgp-af)# bgp dampening 30 1500 10000 120
```

Configures BGP dampening for the specified address family.

### Step 5 Use the **commit** or **end** command.

**commit** —Saves the configuration changes and remains within the configuration session.

**end** —Prompts user to take one of these actions:

- **Yes** — Saves configuration changes and exits the configuration session.
  - **No** —Exits the configuration session without committing the configuration changes.
  - **Cancel** —Remains in the configuration session, without committing the configuration changes.
- 

## Apply Policy When Updating Routing Table

The table policy feature in BGP allows you to configure traffic index values on routes as they are installed in the global routing table. This feature is enabled using the table-policy command and supports the BGP policy accounting feature. Table policy also provides the ability to drop routes from the RIB based on match criteria. This feature can be useful in certain applications and should be used with caution as it can easily create a



routing ‘black hole’ where BGP advertises routes to neighbors that BGP does not install in its global routing table and forwarding table.

Perform this task to apply a routing policy to routes being installed into the routing table.

---

**Step 1** **configure****Example:**

```
RP/0/# configure
```

Enters mode.

**Step 2** **router bgp** *as-number***Example:**

```
Router(config)# router bgp 120.6
```

Specifies the autonomous system number and enters the BGP configuration mode, allowing you to configure the BGP routing process.

**Step 3** **address-family** { **ipv4** | **ipv6** } **unicast****Example:**

```
Router(config-bgp)# address-family ipv4 unicast
```

Specifies either the IPv4 or IPv6 address family and enters address family configuration submenu.

To see a list of all the possible keywords and arguments for this command, use the CLI help (?).

**Step 4** **table-policy** *policy-name***Example:**

```
Router(config-bgp-af)# table-policy tbl-plcy-A
```

Applies the specified policy to routes being installed into the routing table.

**Step 5** Use the **commit** or **end** command.

**commit** —Saves the configuration changes and remains within the configuration session.

**end** —Prompts user to take one of these actions:

- **Yes** — Saves configuration changes and exits the configuration session.
- **No** —Exits the configuration session without committing the configuration changes.
- **Cancel** —Remains in the configuration session, without committing the configuration changes.

---

**Applying routing policy: Example**

In the following example, for an eBGP neighbor, if all routes should be accepted and advertised with no modifications, a simple pass-all policy is configured:

```
Router(config)# route-policy pass-all
Router(config-rpl)# pass
Router(config-rpl)# end-policy
Router(config)# commit
```

Use the **route-policy (BGP)** command in the neighbor address-family configuration mode to apply the pass-all policy to a neighbor. The following example shows how to allow all IPv4 unicast routes to be received from neighbor 192.168.40.42 and advertise all IPv4 unicast routes back to it:

```
Router(config)# router bgp 1
Router(config-bgp)# neighbor 192.168.40.24
Router(config-bgp-nbr)# remote-as 21
Router(config-bgp-nbr)# address-family ipv4 unicast
Router(config-bgp-nbr-af)# route-policy pass-all in
Router(config-bgp-nbr-af)# route-policy pass-all out
Router(config-bgp-nbr-af)# commit
```

Use the **show bgp summary** command to display eBGP neighbors that do not have both an inbound and outbound policy for every active address family. In the following example, such eBGP neighbors are indicated in the output with an exclamation (!) mark:

```
Router# show bgp all all summary

Address Family: IPv4 Unicast
=====

BGP router identifier 10.0.0.1, local AS number 1
BGP generic scan interval 60 secs
BGP main routing table version 41
BGP scan interval 60 secs
BGP is operating in STANDALONE mode.

Process          RecvTblVer    bRIB/RIB    SendTblVer
Speaker
-----
Neighbor         Spk   AS MsgRcvd  MsgSent    TblVer  InQ  OutQ  Up/Down  St/PfxRcd
10.0.101.1        0     1     919      925       41     0    0 15:15:08    10
10.0.101.2        0     2         0         0         0     0    0 00:00:00  Idle
```

## Configure BGP Route Filtering by Route Policy

Perform this task to configure BGP routing filtering by route policy.

- 
- Step 1**    **configure**  
**Step 2**    **route-policy** *name*

**Example:**

```
Router(config)# route-policy drop-as-1234
Router(config-rpl)# if as-path passes-through '1234' then
Router(config-rpl)# apply check-communities
Router(config-rpl)# else
```

```
Router(config-rpl)# pass
Router(config-rpl)# endif
```

(Optional) Creates a route policy and enters route policy configuration mode, where you can define the route policy.

**Step 3** **end-policy**

**Example:**

```
Router(config-rpl)# end-policy
```

(Optional) Ends the definition of a route policy and exits route policy configuration mode.

**Step 4** **router bgp** *as-number*

**Example:**

```
Router(config)# router bgp 120
```

Specifies the autonomous system number and enters the BGP configuration mode, allowing you to configure the BGP routing process.

**Step 5** **neighbor** *ip-address*

**Example:**

```
Router(config-bgp)# neighbor 172.168.40.24
```

Places the router in neighbor configuration mode for BGP routing and configures the neighbor IP address as a BGP peer.

**Step 6** **address-family** { **ipv4** | **ipv6** } **unicast**

**Example:**

```
Router(config-bgp-nbr)# address-family ipv4 unicast
```

Specifies either an IPv4 or IPv6 address family unicast and enters address family configuration submode.

To see a list of all the possible keywords and arguments for this command, use the CLI help (?).

**Step 7** **route-policy** *route-policy-name* { **in** | **out** }

**Example:**

```
Router(config-bgp-nbr-af)# route-policy drop-as-1234 in
```

Applies the specified policy to inbound routes.

**Step 8** **commit**

---

## Configure Destination-based RTBH Filtering

RTBH is implemented by defining a route policy (RPL) to discard undesirable traffic at next-hop using **set next-hop discard** command.

RTBH filtering sets the next-hop of the victim's prefix to the null interface. The traffic destined to the victim is dropped at the ingress.

The **set next-hop discard** configuration is used in the neighbor inbound policy. When this config is applied to a path, though the primary next-hop is associated with the actual path but the RIB is updated with next-hop set to Null0. Even if the primary received next-hop is unreachable, the RTBH path is considered reachable and will be a candidate in the bestpath selection process. The RTBH path is readvertised to other peers with either the received next-hop or nexthop-self based on normal BGP advertisement rules.

A typical deployment scenario for RTBH filtering would require running internal Border Gateway Protocol (iBGP) at the access and aggregation points and configuring a separate device in the network operations center (NOC) to act as a trigger. The triggering device sends iBGP updates to the edge, that cause undesirable traffic to be forwarded to a null0 interface and dropped.

Consider below topology, where a rogue router is sending traffic to a border router.

**Figure 13: Topology to Implement RTBH Filtering**

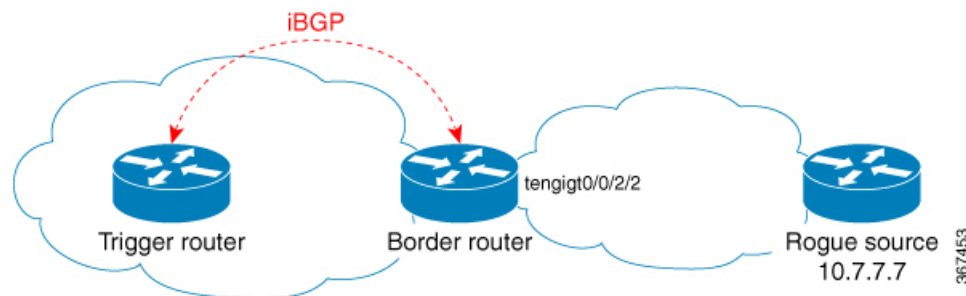

### Configurations applied on the Trigger Router

Configure a static route redistribution policy that sets a community on static routes marked with a special tag, and apply it in BGP:

```
route-policy RTBH-trigger
  if tag is 777 then
    set community (1234:4321, no-export) additive
    pass
  else
    pass
  endif
end-policy
```

```
router bgp 65001
  address-family ipv4 unicast
    redistribute static route-policy RTBH-trigger
  !
  neighbor 192.168.102.1
    remote-as 65001
  address-family ipv4 unicast
    route-policy bgp_all in
    route-policy bgp_all out
```

Configure a static route with the special tag for the source prefix that has to be block-holed:

```
router static
  address-family ipv4 unicast
  10.7.7.7/32 Null0 tag 777
```

### Configurations applied on the Border Router

Configure a route policy that matches the community set on the trigger router and configure set next-hop discard:

```
route-policy RTBH
  if community matches-any (1234:4321) then
    set next-hop discard
  else
    pass
  endif
end-policy
```

Apply the route policy on the iBGP peers:

```
router bgp 65001
  address-family ipv4 unicast
  !
  neighbor 192.168.102.2
    remote-as 65001
    address-family ipv4 unicast
    route-policy RTBH in
    route-policy bgp_all out
```

## Resilient Hashing and Flow Auto-Recovery

Resilient Hashing and Flow Auto-Recovery feature provides an option to selectively override the default equal cost multipath (ECMP) behavior during a ECMP path failure. This feature enables the redirection of flows through inactive links only and the prevention of all existing flows from being rehashed to a new link. This feature also provides an option to recover a link or a server when it comes back so it can be reused for sessions.

### ECMP Path Failure

Prior to the implementation of Resilient Hashing and Flow Auto-Recovery feature, ECMP would load balance the traffic over a number of available paths towards a destination. When one path fails, the traffic gets rehashed over a new set of paths and elects a new next-hop for each path.

**Figure 14: ECMP Path Failure**

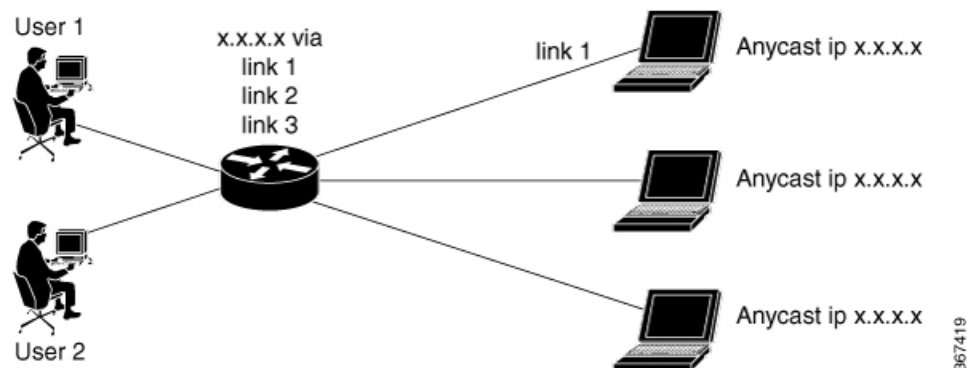

For example, as shown in the figure, among three links link 1, link 2, and link 3, the traffic flow that took link 1 before the failure, takes link 3 after the failure although only link 2 failed.

This traffic flow redistribution does not cause any problem in traditional core networks because the end-to-end connectivity is preserved and the user does not encounter problems from it. However, in data center environments, load balancing due to traffic flow redistribution can cause a problem.

In data center environments where multiple servers are connected through ECMP, the loss of traffic on active link caused by this rehashing resets the TCP session.

**Figure 15: Resilient Hashing and Flow Auto-Recovery**

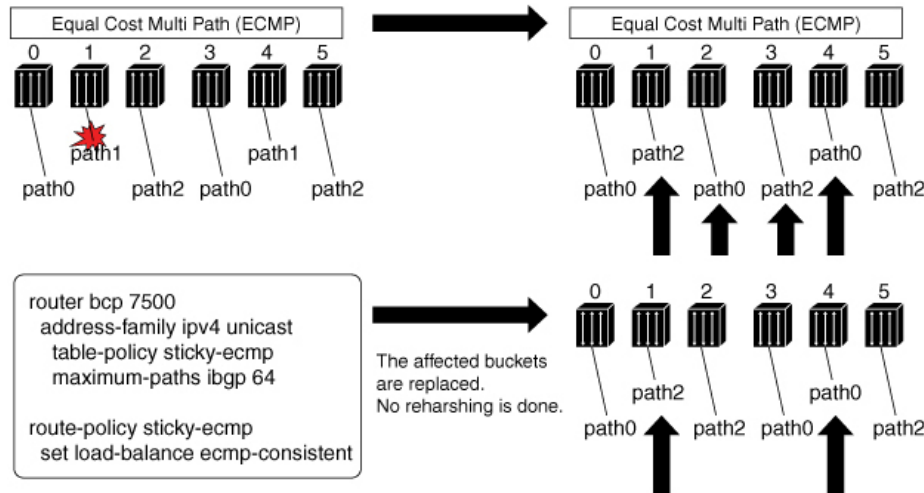

The above figure shows how complete rehashing of paths occurs when path 1 fails. However, when Resilient Hashing and Flow Auto-Recovery feature is configured, only the affected buckets are replaced. No rehashing is done. Use an RPL to define prefixes that require resilient hashing and flow auto-recovery. Each prefix has a path list, say for example a prefix 'X' has a path list namely, path 0, path 1, path 2. For example, when path 1 fails and when you have configured Resilient Hashing and Flow Auto-Recovery feature, the new path list becomes (path 0, path 0, and path 2), instead of the default rehash logic, which results (path 0, path 2, and path 0).

When path 1 becomes active, if the Resilient Hashing and Flow Auto-Recovery feature is not configured, no rehashing is done and the path is not utilized until one of the following occurs:

- Addition of new path to ECMP
- Use of **clear route** command.
- Removal of table-policy, commit, addition of table-policy, and commit
- Configuration of **cef consistent-hashing auto-recovery** command

When path 1 becomes active, if the Resilient Hashing and Flow Auto-Recovery feature is configured, the sessions get reshuffled automatically. This causes the sessions, which were moved from the failed path to a new server, to be rehashed back to the original server that became active. Hence, only these sessions are disrupted.

# Persistent Loadbalancing

Traditional ECMP or equal cost multipath loadbalances traffic over a number of available paths towards a destination. When one path fails, the traffic gets re-shuffled over the available number of paths. This flow distribution can be a problem in data center loadbalancing.

Persistent Loadbalancing or Sticky ECMP defines a prefix in such a way that it do not rehash flows on existing paths and only replace those bucket assignments of the failed server. The advantage is that the established sessions to servers will not get rehashed.

The following section describes how you can configure persistent load balancing:

```
/*Configure persistent load balancing. */

Router(config)# router bgp 7500
Router(config-bgp)# address-family ipv4 unicast
Router(config-bgp-af)# table-policy sticky-ecmp
Router(config-bgp-af)# bgp attribute-download
Router(config-bgp-af)# maximum-paths ebgp 64
Router(config-bgp-af)# maximum-paths ibgp 32
Router(config-bgp-af)# exit
Router(config-bgp)# exit
Router(config)# route-policy sticky-ecmp
Router(config-rpl)# if destination in (192.1.1.1/24) then
Router(config-rpl-if)# set load-balance ecmp-consistent
Router(config-rpl-if)# else
Router(config-rpl-else)# pass
Router(config-rpl-else)# endif
RP/0/0/CPU0:ios(config-rpl)# end-policy
RP/0/0/CPU0:ios(config)#

/* Enable autocoverry and hence recover the original hashing state
after failed paths become active. */
Router(config)# cef consistent-hashing auto-recovery

/* Recover to the original hashing state after failed paths come up
and avoid affecting newly formed flows after path failure. */
Router(config)# clear route 192.0.2.0/24
```

## Running Configuration

```
/* Configure persistent loadbalancing. */
router bgp 7500
 address-family ipv4 unicast
   table-policy sticky-ecmp
   bgp attribute-download
   maximum-paths ebgp 64
   maximum-paths ibgp 32

cef consistent-hashing auto-recovery

clear route 192.0.2.0/24
```

## Verification

Verify that the path distribution with persistent loadbalancing is configured.

The following show output displays the status of path distribution before a link fails. In this output, three paths are identified with three next hops (10.1/2/3.0.1) through three different GigabitEthernet interfaces.

**show cef 192.0.2.0/24**

```
LDI Update time Sep  5 11:22:38.201
  via 10.1.0.1/32, 3 dependencies, recursive, bgp-multipath [flags 0x6080]
    path-idx 0 NHID 0x0 [0x57ac4e74 0x0]
    next hop 10.1.0.1/32 via 10.1.0.1/32
  via 10.2.0.1/32, 3 dependencies, recursive, bgp-multipath [flags 0x6080]
    path-idx 1 NHID 0x0 [0x57ac4a74 0x0]
    next hop 10.2.0.1/32 via 10.2.0.1/32
  via 10.3.0.1/32, 3 dependencies, recursive, bgp-multipath [flags 0x6080]
    path-idx 2 NHID 0x0 [0x57ac4f74 0x0]
    next hop 10.3.0.1/32 via 10.3.0.1/32
```

```
Load distribution (consistent): 0 1 2 (refcount 1)
```

Hash	OK	Interface	Address
0	Y	GigabitEthernet0/0/0/0	10.1.0.1
1	Y	GigabitEthernet0/0/0/1	10.2.0.1
2	Y	GigabitEthernet0/0/0/2	10.3.0.1

The following show output displays the status of the path distribution after a link fails. The replacement of bucket 1 with GigabitEthernet 0/0/0/0 and the "\*" symbol denotes that this path is a replacement for a failed path.

**show cef 192.0.2.0/24**

```
LDI Update time Sep  5 11:23:13.434
  via 10.1.0.1/32, 3 dependencies, recursive, bgp-multipath [flags 0x6080]
    path-idx 0 NHID 0x0 [0x57ac4e74 0x0]
    next hop 10.1.0.1/32 via 10.1.0.1/32
  via 10.3.0.1/32, 3 dependencies, recursive, bgp-multipath [flags 0x6080]
    path-idx 1 NHID 0x0 [0x57ac4f74 0x0]
    next hop 10.3.0.1/32 via 10.3.0.1/32
```

```
Load distribution (consistent) : 0 1 2 (refcount 1)
```

Hash	OK	Interface	Address
0	Y	GigabitEthernet0/0/0/0	10.1.0.1
<b>1*</b>	<b>Y</b>	<b>GigabitEthernet0/0/0/0</b>	<b>10.1.0.1</b>
2	Y	GigabitEthernet0/0/0/2	10.3.0.1

## BGP Selective Multipath

Traditional BGP multipath feature allows a router receiving parallel paths to the same destination to install the multiple paths in the routing table. By default, this multipath feature is applied to all configured peers. BGP selective multipath allows application of the multipath feature only to selected peers.

The BGP router receiving multiple paths is configured with the **maximum-paths ... selective** option. The iBGP/eBGP neighbors sharing multiple paths are configured with the **multipath** option, while being added as neighbors on the BGP router.



---

**Note** Use **next-hop-unchanged multipath** command to avoid overwriting next-hop information before advertising multipaths.

---

The following behavior is to be noted while using BGP selective multipath:



- BGP selective multipath does not impact best path calculations. A best path is always included in the set of multipaths.
- For VPN prefixes, the PE paths are *always* eligible to be multipaths.

### Topology

A sample topology to illustrate the configuration used in this section is shown in the following figure.

**Figure 16: BGP Selective Multipath**

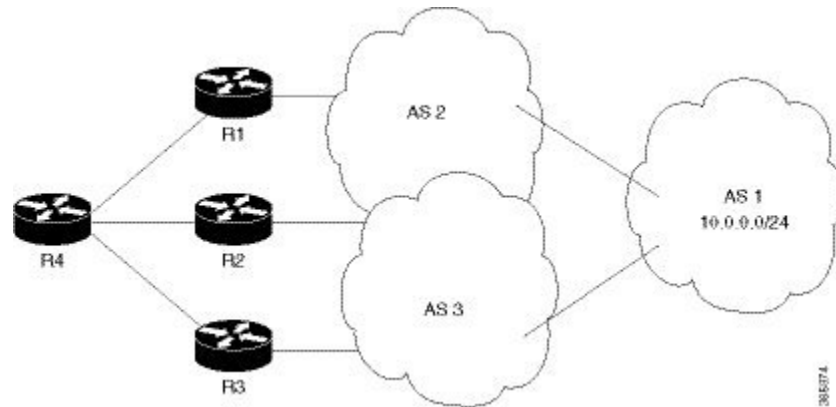

Router R4 receives parallel paths from Routers R1, R2 and R3 to the same destination. If Routers R1 and R2 are configured as selective multipath neighbors on Router R4, only the parallel paths from these routers are installed in the routing table of Router R4.

### Configuration



**Note** Configure your network topology with iBGP/eBGP running on your routers, before configuring this feature.

To configure BGP selective multipath on Router R4, use the following steps.

1. Configure Router R4 to accept selective multiple paths in your topology.

```
/* To configure selective multipath for iBGP/eBGP
Router(config)# router bgp 1
Router(config-bgp)# address-family ipv4 unicast
Router(config-bgp-af)# maximum-paths ibgp 4 selective
Router(config-bgp-af)# maximum-paths ebgp 5 selective
Router(config-bgp-af)# commit

/* To configure selective multipath for eiBGP
Router(config)# router bgp 1
Router(config-bgp)# address-family ipv4 unicast
Router(config-bgp-af)# maximum-paths eiBGP 6 selective
Router(config-bgp-af)# commit
```

2. Configure neighbors for Router R4.

Routers R1 (1.1.1.1) and R2 (2.2.2.2) are configured as neighbors with the **multipath** option.

Router R3 (3.3.3.3) is configured as a neighbor without the **multipath** option, and hence the routes from this router are not eligible to be chosen as multipaths.

```
Router(config-bgp)# neighbor 1.1.1.1
Router(config-bgp-nbr)# address-family ipv4 unicast
Router(config-bgp-nbr-af)# multipath
Router(config-bgp-nbr-af)# commit

Router(config-bgp-nbr)# neighbor 2.2.2.2
Router(config-bgp-nbr)# address-family ipv4 unicast
Router(config-bgp-nbr-af)# multipath
Router(config-bgp-nbr-af)# commit

Router(config-bgp-nbr)# neighbor 3.3.3.3
Router(config-bgp-nbr)# address-family ipv4 unicast
Router(config-bgp-nbr-af)# commit
```

You have successfully configured the BGP selective multipath feature.

## Remove and Replace Private AS Numbers from AS Path in BGP

Private autonomous system numbers (ASNs) are used by Internet Service Providers (ISPs) and customer networks to conserve globally unique AS numbers. Private AS numbers cannot be used to access the global Internet because they are not unique. AS numbers appear in eBGP AS paths in routing updates. Removing private ASNs from the AS path is necessary if you have been using private ASNs and you want to access the global Internet.

Public AS numbers are assigned by InterNIC and are globally unique. They range from 1 to 64511. Private AS numbers are used to conserve globally unique AS numbers, and they range from 64512 to 65535. Private AS numbers cannot be leaked to a global BGP routing table because they are not unique, and BGP best path calculations require unique AS numbers. Therefore, it might be necessary to remove private AS numbers from an AS path before the routes are propagated to a BGP peer.

External BGP (eBGP) requires that globally unique AS numbers be used when routing to the global Internet. Using private AS numbers (which are not unique) would prevent access to the global Internet. The remove and replace private AS Numbers from AS Path in BGP feature allows routers that belong to a private AS to access the global Internet. A network administrator configures the routers to remove private AS numbers from the AS path contained in outgoing update messages and optionally, to replace those numbers with the ASN of the local router, so that the AS Path length remains unchanged.

The ability to remove and replace private AS numbers from the AS Path is implemented in the following ways:

- The **remove-private-as** command removes private AS numbers from the AS path even if the path contains both public and private ASNs.
- The **remove-private-as** command removes private AS numbers even if the AS path contains only private AS numbers. There is no likelihood of a 0-length AS path because this command can be applied to eBGP peers only, in which case the AS number of the local router is appended to the AS path.
- The **remove-private-as** command removes private AS numbers even if the private ASNs appear before the confederation segments in the AS path.

- The **replace-as** command replaces the private AS numbers being removed from the path with the local AS number, thereby retaining the same AS path length.

The feature can be applied to neighbors per address family (address family configuration mode). Therefore, you can apply the feature for a neighbor in one address family and not on another, affecting update messages on the outbound side for only the address family for which the feature is configured.

Use **show bgp neighbors** and **show bgp update-group** commands to verify that the that private AS numbers were removed or replaced.

## BGP DMZ Link Bandwidth for Unequal Cost Recursive Load Balancing

Border Gateway Protocol demilitarized zone (BGP DMZ) Link Bandwidth for Unequal Cost Recursive Load Balancing provides support for unequal cost load balancing for recursive prefixes on local node using BGP DMZ Link Bandwidth. The unequal load balance is achieved by using the **dmz-link-bandwidth** command in BGP Neighbor configuration mode and the **bandwidth** command in Interface configuration mode.

## BGP Multi-Instance and Multi-AS

Multi-AS BGP enables configuring each instance of a multi-instance BGP with a different AS number. Multi-Instance and Multi-AS BGP provides these capabilities:

- Mechanism to consolidate the services provided by multiple routers using a common routing infrastructure into a single IOS-XR router.
- Mechanism to achieve AF isolation by configuring the different AFs in different BGP instances.
- Means to achieve higher session scale by distributing the overall peering sessions between multiple instances.
- Mechanism to achieve higher prefix scale (especially on a RR) by having different instances carrying different BGP tables.
- Improved BGP convergence under certain scenarios.
- All BGP functionalities including NSR are supported for all the instances.
- The load and commit router-level operations can be performed on previously verified or applied configurations.

### Restrictions

- The router supports maximum of 4 BGP instances.
- Each BGP instance needs a unique router-id.
- Only one Address Family can be configured under each BGP instance (VPNv4, VPNv6 and RT-Constrain can be configured under multiple BGP instances).

- IPv4/IPv6 Unicast should be within the same BGP instance in which IPv4/IPv6 Labeled-Unicast is configured.
- IPv4/IPv6 Multicast should be within the same BGP instance in which IPv4/IPv6 Unicast is configured.
- All configuration changes for a single BGP instance can be committed together. However, configuration changes for multiple instances cannot be committed together.
- Cisco recommends that BGP update-source should be unique in the default VRF over all instances while peering with the same remote router.

## BGP Prefix Origin Validation Based on RPKI

A BGP route associates an address prefix with a set of autonomous systems (AS) that identify the interdomain path the prefix has traversed in the form of BGP announcements. This set is represented as the AS\_PATH attribute in BGP and starts with the AS that originated the prefix.

To help reduce well-known threats against BGP including prefix mis-announcing and monkey-in-the-middle attacks, one of the security requirements is the ability to validate the origination AS of BGP routes. The AS number claiming to originate an address prefix (as derived from the AS\_PATH attribute of the BGP route) needs to be verified and authorized by the prefix holder. The Resource Public Key Infrastructure (RPKI) is an approach to build a formally verifiable database of IP addresses and AS numbers as resources. The RPKI is a globally distributed database containing, among other things, information mapping BGP (internet) prefixes to their authorized origin-AS numbers. Routers running BGP can connect to the RPKI to validate the origin-AS of BGP paths.

### Configure RPKI Cache-server

Perform this task to configure Resource Public Key Infrastructure (RPKI) cache-server parameters.

Configure the RPKI cache-server parameters in `rpki-server` configuration mode. Use the `rpki server` command in router BGP configuration mode to enter into the `rpki-server` configuration mode

---

#### Step 1 **configure**

##### Example:

```
RP/0/# configure
```

Enters mode.

#### Step 2 **router bgp** *as-number*

##### Example:

```
Router(config)#router bgp 100
```

Specifies the BGP AS number and enters the BGP configuration mode, allowing you to configure the BGP routing process.

#### Step 3 **rpki cache** {*host-name* | *ip-address*}

##### Example:

```
Router(config-bgp)#rpki server 10.2.3.4
```

Enters `rpki-server` configuration mode and enables configuration of RPKI cache parameters.

**Step 4** Use one of these commands:

- **transport ssh port** *port\_number*
- **transport tcp port** *port\_number*

**Example:**

```
Router(config-bgp-rpki-server)#transport ssh port 22
```

Or

```
Router(config-bgp-rpki-server)#transport tcp port 2
```

Specifies a transport method for the RPKI cache.

- **ssh**—Select **ssh** to connect to the RPKI cache using SSH.
- **tcp**—Select **tcp** to connect to the RPKI cache using TCP (unencrypted).
- **port** *port\_number*—Specify the port number for the RPKI cache transport over TCP and SSH protocols. The port number ranges from 1 to 65535.

- Note**
- SSH supports custom ports in addition to the default port number 22.
  - You can set the transport to either TCP or SSH. Change of transport causes the cache session to flap.

**Step 5** (Optional) **username** *user\_name*

**Example:**

```
Router(config-bgp-rpki-server)#username ssh_rpki_cache
```

Specifies a (SSH) username for the RPKI cache-server.

**Step 6** (Optional) **password**

**Example:**

```
Router(config-bgp-rpki-server)#password ssh_rpki_pass
```

Specifies a (SSH) password for the RPKI cache-server.

**Note** The “username” and “password” configurations only apply if the SSH method of transport is active.

**Step 7** **preference** *preference\_value*

**Example:**

```
Router(config-bgp-rpki-server)#preference 1
```

Specifies a preference value for the RPKI cache. Range for the preference value is 1 to 10. Setting a lower preference value is better.

**Step 8** **purge-time** *time*

**Example:**

```
Router(config-bgp-rpki-server)#purge-time 30
```

Configures the time BGP waits to keep routes from a cache after the cache session drops. Set purge time in seconds. Range for the purge time is 30 to 360 seconds.

**Step 9** Use one of these commands.

- **refresh-time** *time*
- **refresh-time off**

**Example:**

```
Router(config-bgp-rpki-server)#refresh-time 20
```

Or

```
Router(config-bgp-rpki-server)#refresh-time off
```

Configures the time BGP waits in between sending periodic serial queries to the cache. Set refresh-time in seconds. Range for the refresh time is 15 to 3600 seconds.

Configure the **off** option to specify not to send serial-queries periodically.

**Step 10** Use one these commands.

- **response-time** *time*
- **response-time off**

**Example:**

```
Router(config-bgp-rpki-server)#response-time 30
```

Or

```
Router(config-bgp-rpki-server)#response-time off
```

Configures the time BGP waits for a response after sending a serial or reset query. Set response-time in seconds. Range for the response time is 15 to 3600 seconds.

Configure the **off** option to wait indefinitely for a response.

**Step 11** **shutdown**

**Example:**

```
Router(config-bgp-rpki-server)#shutdown
```

Configures shut down of the RPKI cache.

**Step 12** Use the **commit** or **end** command.

**commit** —Saves the configuration changes and remains within the configuration session.

**end** —Prompts user to take one of these actions:

- **Yes** — Saves configuration changes and exits the configuration session.
- **No** —Exits the configuration session without committing the configuration changes.
- **Cancel** —Remains in the configuration session, without committing the configuration changes.

---

## BGP Update Message Error Handling

The BGP UPDATE message error handling changes BGP behavior in handling error UPDATE messages to avoid session reset. Based on the approach described in IETF IDR *I-D:draft-ietf-idr-error-handling*, the Cisco

IOS XR BGP UPDATE Message Error handling implementation classifies BGP update errors into various categories based on factors such as, severity, likelihood of occurrence of UPDATE errors, or type of attributes. Errors encountered in each category are handled according to the draft. Session reset will be avoided as much as possible during the error handling process. Error handling for some of the categories are controlled by configuration commands to enable or disable the default behavior.

According to the base BGP specification, a BGP speaker that receives an UPDATE message containing a malformed attribute is required to reset the session over which the offending attribute was received. This behavior is undesirable as a session reset would impact not only routes with the offending attribute, but also other valid routes exchanged over the session.

## BGP Attribute Filtering

The BGP Attribute Filter feature checks integrity of BGP updates in BGP update messages and optimizes reaction when detecting invalid attributes. BGP Update message contains a list of mandatory and optional attributes. These attributes in the update message include MED, LOCAL\_PREF, COMMUNITY etc. In some cases, if the attributes are malformed, there is a need to filter these attributes at the receiving end of the router. The BGP Attribute Filter functionality filters the attributes received in the incoming update message. The attribute filter can also be used to filter any attributes that may potentially cause undesirable behavior on the receiving router.

Some of the BGP updates are malformed due to wrong formatting of attributes such as the network layer reachability information (NLRI) or other fields in the update message. These malformed updates, when received, causes undesirable behavior on the receiving routers. Such undesirable behavior may be encountered during update message parsing or during re-advertisement of received NLRIs. In such scenarios, its better to filter these corrupted attributes at the receiving end.

## BGP Error Handling and Attribute Filtering Syslog Messages

When a router receives a malformed update packet, an ios\_msg of type ROUTING-BGP-3-MALFORM\_UPDATE is printed on the console. This is rate limited to 1 message per minute across all neighbors. For malformed packets that result in actions "Discard Attribute" (A5) or "Local Repair" (A6), the ios\_msg is printed only once per neighbor per action. This is irrespective of the number of malformed updates received since the neighbor last reached an "Established" state.

This is a sample BGP error handling syslog message:

```
%ROUTING-BGP-3-MALFORM_UPDATE : Malformed UPDATE message received from neighbor 13.0.3.50
- message length 90 bytes,
  error flags 0x00000840, action taken "TreatAsWithdraw".
Error details: "Error 0x00000800, Field "Attr-missing", Attribute 1 (Flags 0x00, Length 0),
  Data []"
```

This is a sample BGP attribute filtering syslog message for the "discard attribute" action:

```
4843.46]RP/0/0/CPU0:Aug 21 17:06:17.919 : bgp[1037]: %ROUTING-BGP-5-UPDATE_FILTERED :
One or more attributes were filtered from UPDATE message received from neighbor 40.0.101.1
- message length 173 bytes,
  action taken "DiscardAttr".
Filtering details: "Attribute 16 (Flags 0xc0): Action "DiscardAttr"". NLRIs: [IPv4 Unicast]
```

```
88.2.0.0/17
```

This is a sample BGP attribute filtering syslog message for the "treat-as-withdraw" action:

```
[391.01]RP/0/0/CPU0:Aug 20 19:41:29.243 : bgp[1037]: %ROUTING-BGP-5-UPDATE_FILTERED :  
One or more attributes were filtered from UPDATE message received from neighbor 40.0.101.1  
- message length 166 bytes,  
action taken "TreatAsWdr".  
Filtering details: "Attribute 4 (Flags 0xc0): Action "TreatAsWdr"". NLRI: [IPv4 Unicast]  
88.2.0.0/17
```

## BGP-RIB Feedback Mechanism for Update Generation

The Border Gateway Protocol-Routing Information Base (BGP-RIB) feedback mechanism for update generation feature avoids premature route advertisements and subsequent packet loss in a network. This mechanism ensures that routes are installed locally, before they are advertised to a neighbor.

BGP waits for feedback from RIB indicating that the routes that BGP installed in RIB are installed in forwarding information base (FIB) before BGP sends out updates to the neighbors. RIB uses the the BCDL feedback mechanism to determine which version of the routes have been consumed by FIB, and updates the BGP with that version. BGP will send out updates of only those routes that have versions up to the version that FIB has installed. This selective update ensures that BGP does not send out premature updates resulting in attracting traffic even before the data plane is programmed after router reload, LC OIR, or flap of a link where an alternate path is made available.

To configure BGP to wait for feedback from RIB indicating that the routes that BGP installed in RIB are installed in FIB, before BGP sends out updates to neighbors, use the **update wait-install** command in router address-family IPv4 or router address-family VPNv4 configuration mode. The **show bgp**, **show bgp neighbors**, and **show bgp process performance-statistics** commands display the information from update wait-install configuration.

## Configure BGP Large Communities

BGP communities provide a way to group destinations and apply routing decisions such as acceptance, rejection, preference, or redistribution on a group of destinations using community attributes. BGP community attributes are variable length attributes consisting of a set of one or more 4-byte values which are split into two parts of 16 bits. The higher-order 16 bits represents the AS number and the lower order bits represents a locally defined value assigned by the operator of the AS.

Since the adoption of 4-byte ASNs (RFC6793), the BGP communities attribute can no longer accommodate the 4 byte ASNs as you need more than 4 bytes to encode the 4-byte ASN and an AS specific value that you want to tag with the route. Although BGP extended community permits a 4-byte AS to be encoded as the global administrator field, the local administrator field has only 2-byte of available space. So, 6-byte extended community attribute is also unsuitable. To overcome this limitation, you can configure a 12-byte BGP large community which is an optional attribute that provides the most significant 4-byte value to encode autonomous system number as the global administrator and the remaining two 4-byte assigned numbers to encode the local values.



Similar to BGP communities, routers can apply BGP large communities to BGP routes by using route policy languages (RPL) and other routers can then perform actions based on the community that is attached to the route. The policy language provides sets as a container for groups of values for matching purposes.

When large communities are specified in other commands, they are specified as three non negative decimal integers separated by colons. For example, 1:2:3. Each integer is stored in 32 bits. The possible range for each integer is 0 to 4294967295.

In route-policy statements, each integer in the BGP large community can be replaced by any of the following expressions :

- [x..y] — This expression specifies a range between x and y, inclusive.
- \* —This expression stands for any number.
- peeras — This expression is replaced by the AS number of the neighbor from which the community is received or to which the community is sent, as appropriate.
- not-peeras —This expression matches any number other than the peeras.
- private-as — This expression specifies any number in the private ASN range: [64512..65534] and [4200000000..4294967294].

These expressions can be also used in policy-match statements.

IOS regular expression (`ios-regex`) and DFA style regular expression (`dfa-regex`) can be used in any of the large-community policy match and delete statements. For example, the IOS regular expression `ios-regex '^5.:*:7$'` is equivalent to the expression `5:*:7`.

The **send-community-ebgp** command is extended to include BGP large communities. This command is required for the BGP speaker to send large communities to ebgp neighbors.

### Restrictions and Guidelines

The following restrictions and guidelines apply for BGP large communities:

- All functionalities of the BGP community attribute is available for the BGP large-community attribute.
- The **send-community-ebgp** command is required for the BGP speaker to send large communities to ebgp neighbors.
- There are no well-known large-communities.
- The peeras expression cannot be used in a large-community-set.
- The peeras expression can only be used in large-community match or delete statements that appear in route policies that are applied at the neighbor-in or neighbor-out attach points.
- The not-peeras expression cannot be used in a large-community-set or in policy set statements.

### Configuration Example: Large Community Set

A large-community set defines a set of large communities. Named large-community sets are used in route-policy match and set statements.

This example shows how to create a named large-community set.

```
Router(config)# large-community-set catbert
Router(config-largecomm)# 1: 2: 3,
```

```
Router(config-largecomm)# peeras:2:3
Router(config-largecomm)# end-set
```

### Configuration Example: Set Large Community

The following example shows how to set the BGP large community attribute in a route, using the **set large-community** {*large-community-set-name* | *inline-large-community-set* | *parameter* } [**additive** ] command. You can specify a named large-community-set or an inline set. The **additive** keyword retains the large communities already present in the route and adds the new set of large communities. However the **additive** keyword does not result in duplicate entries.

If a particular large community is attached to a route and you specify the same large community again with the additive keyword in the set statement, then the specified large community is not added again. The merging operation removes duplicate entries. This also applies to the peeras keyword.

The peeras expression in the example is replaced by the AS number of the neighbor from which the BGP large community is received or to which the community is sent, as appropriate.

```
Router(config)# route-policy mordac
Router(config-rpl)# set large-community (1:2:3, peeras:2:3)
Router(config-rpl)# end-set
Router(config)# large-community-set catbert
Router(config-largecomm)# 1: 2: 3,
Router(config-largecomm)# peeras:2:3
Router(config-largecomm)# end-set
Router(config)# route-policy wally
Router(config-rpl)# set large-community catbert additive
Router(config-rpl)# end-set
```

In this example, if the route-policy mordac is applied to a neighbor, the ASN of which is 1, then the large community (1:2:3) is set only once.



---

**Note** You should configure the **send-community-ebgp** command to send large communities to ebgp neighbors.

---

### Configuration Example: Large Community Matches-any

The following example shows how to configure a route policy to match any element of a large -community set. This is a boolean condition and returns true if any of the large communities in the route match any of the large communities in the match condition.

```
Router(config)# route-policy elbonia
Router(config-rpl)# if large-community matches-any (1:2:3, 4:5:*) then
Router(config-rpl)#   set local-preference 94
Router(config-rpl)# endif
Router(config-rpl)# end-policy
```

### Configuration Example: Large Community Matches-every

The following example shows how to configure a route policy where every match specification in the statement must be matched by at least one large community in the route.

```
Router(config)# route-policy bob
Router(config-rpl)# if large-community matches-every (*:3, 4:5:*) then
Router(config-rpl)#   set local-preference 94
Router(config-rpl)# endif
Router(config-rpl)# end-policy
```

In this example, routes with these sets of large communities return TRUE:

- (1:1:3, 4:5:10)
- (4:5:3) —This single large community matches both specifications.
- (1:1:3, 4:5:10, 7:6:5)

Routes with the following set of large communities return FALSE:

(1:1:3, 5:5:10)—The specification (4:5:\*) is not matched.

### Configuration Example: Large Community Matches-within

The following example shows how to configure a route policy to match within a large community set. This is similar to the **large-community matches-any** command but every large community in the route must match at least one match specification. Note that if the route has no large communities, then it matches.

```
Router(config)# route-policy bob
Router(config-rpl)# if large-community matches-within (*:3, 4:5:*) then
Router(config-rpl)#   set local-preference 103
Router(config-rpl)# endif
Router(config-rpl)# end-policy
```

For example, routes with these sets of large communities return TRUE:

- (1:1:3, 4:5:10)
- (4:5:3)
- (1:2:3, 6:6:3, 9:4:3)

Routes with this set of large communities return FALSE:

(1:1:3, 4:5:10, 7:6:5) —The large community (7:6:5) does not match

### Configuration Example: Community Matches-within

The following example shows how to configure a route policy to match within the elements of a community set. This command is similar to the **community matches-any** command, but every community in the route must match at least one match specification. If the route has no communities, then it matches.

```
Router(config)# route-policy bob
Router(config-rpl)# if community matches-within (*:3, 5:*) then
Router(config-rpl)#   set local-preference 94
Router(config-rpl)# endif
Router(config-rpl)# end-policy
```

For example, routes with these sets of communities return TRUE:

- (1:3, 5:10)
- (5:3)
- (2:3, 6:3, 4:3)

Routes with this set of communities return FALSE:

(1:3, 5:10, 6:5) —The community (6:5) does not match.

### Configuration Example: Large Community Is-empty

The following example shows using the **large-community is-empty** clause to filter routes that do not have the large-community attribute set.

```
Router(config)# route-policy lrg_comm_rp4
Router(config-rpl)# if large-community is-empty then
Router(config-rpl)#   set local-preference 104
Router(config-rpl)# endif
Router(config-rpl)# end-policy
```

### Configuration Example: Attribute Filter Group

The following example shows how to configure and apply the attribute-filter group with large-community attributes for a BGP neighbor. The filter specifies the BGP path attributes and an action to take when BGP update message is received. If an update message is received from the BGP neighbor that contains any of the specified attributes, then the specified action is taken. In this example, the attribute filter named dogbert is created and applied to the BGP neighbor 10.0.1.101. It specifies the large community attribute and the action of discard. That means, if the large community BGP path attribute is received in a BGP UPDATE message from the neighbor 10.0.1.101 then the attribute will be discarded before further processing of the message.

```
Router(config)# router bgp 100
Router(config-bgp)# attribute-filter group dogbert
Router(config-bgp-attrfg)# attribute LARGE-COMMUNITY discard
Router(config-bgp-attrfg)# neighbor 10.0.1.101
Router(config-bgp-nbr)# remote-as 6461
Router(config-bgp-nbr)# update in filtering
Router(config-nbr-upd-filter)# attribute-filter group dogbert
```

### Configuration Example: Deleting Large Community

The following example shows how to delete specified BGP large-communities from a route policy using the **delete large-community** command.

```
Router(config)# route-policy lrg_comm_rp2
Router(config-rpl)# delete large-community in (ios-regex '^10000:')
Router(config-rpl)# delete large-community all
Router(config-rpl)# delete large-community not in (peeras:*, 41289:*)
```

### Verification

This example displays the routes with large-communities given in the **show bgp large-community list-of-large-communities [exact-match ]** command. If the optional keyword exact-match is used, then the listed routes will contain only the specified large communities. Otherwise, the displayed routes may contain additional large communities.

```
Router:R1# show bgp large-community 1:2:3 5:6:7
Thu Mar 23 14:40:33.597 PDT
BGP router identifier 4.4.4.4, local AS number 3
BGP generic scan interval 60 secs
Non-stop routing is enabled
BGP table state: Active
Table ID: 0xe0000000 RD version: 66
BGP main routing table version 66
BGP NSR Initial initsync version 3 (Reached)
BGP NSR/ISSU Sync-Group versions 66/0
BGP scan interval 60 secs
```

```

Status codes: s suppressed, d damped, h history, * valid, > best
               i - internal, r RIB-failure, S stale, N Nexthop-discard
Origin codes: i - IGP, e - EGP, ? - incomplete
  Network          Next Hop          Metric LocPrf Weight Path
* 10.0.0.3/32      10.10.10.3          0      94      0 ?
* 10.0.0.5/32      10.11.11.5          0              0 5 ?

```

This example displays the large community attached to a network using the **show bgp ip-address/prefix-length** command.

```

Router:R4# show bgp 10.3.3.3/32
Thu Mar 23 14:36:15.301 PDT
BGP routing table entry for 10.3.3.3/32
Versions:
  Process          bRIB/RIB  SendTblVer
  Speaker          42        42
Last Modified: Mar 22 20:04:46.000 for 18:31:30
Paths: (1 available, best #1)
  Advertised to peers (in unique update groups):
    10.11.11.5
  Path #1: Received by speaker 0
  Advertised to peers (in unique update groups):
    10.11.11.5
Local
  10.10.10.3 from 10.10.10.3 (10.3.3.3)
    Origin incomplete, metric 0, localpref 94, valid, internal, best, group-best
    Received Path ID 0, Local Path ID 0, version 42
    Community: 258:259 260:261 262:263 264:265
    Large Community: 1:2:3 5:6:7 4123456789:4123456780:4123456788

```

## Resetting an eBGP Session Immediately Upon Link Failure

By default, if a link goes down, all BGP sessions of any directly adjacent external peers are immediately reset. Use the **bgp fast-external-fallover disable** command to disable automatic resetting. Turn the automatic reset back on using the **no bgp fast-external-fallover disable** command.

eBGP sessions flap when the node reaches 3500 eBGP sessions with BGP timer values set as 10 and 30. To support more than 3500 eBGP sessions, increase the packet rate by using the **lpts pifib hardware police location location-id** command. Following is a sample configuration to increase the eBGP sessions:

```

Router# configure
Router(config)# lpts pifib hardware police location 0/2/CPU0
Router(config-pifib-policer-per-node)#flow bgp configured rate 4000
Router(config-pifib-policer-per-node)#flow bgp known rate 4000
Router(config-pifib-policer-per-node)#flow bgp default rate 4000
Router(config-pifib-policer-per-node)#commit

```

## Management Information Base (MIBs) for BGP

Cisco IOS XR supports full MIBs and traps for OSPFv2/v3, as defined in RFC 4273. The RFC 4273 defines objects of the Management Information Base (MIB) for use with the BGP Routing Protocol.

To know more about MIBS, please use the [MIB Locator](#).

# Virtual Routing Forwarding Next Hop Routing Policy

Table 13: Feature History Table

Feature Name	Release Name	Description
Virtual Routing Forwarding Next Hop Routing Policy	Release 7.11.1	<p>You can now enable a route policy at the BGP next-hop attach point to limit notifications delivered to BGP for specific prefixes, which equips you with better control over routing decisions, and allows for precise traffic engineering and security compliance for each VRF instance, and helps establish redundant paths specific to each VRF.</p> <p>The feature introduces these changes:</p> <p><b>CLI:</b></p> <p>Modified Command:</p> <ul style="list-style-type: none"> <li>The <code>nexthop route-policy</code> command is extended to VRF address-family configuration mode.</li> </ul> <p><b>YANG Data Model</b></p> <ul style="list-style-type: none"> <li>New XPath for <code>Cisco-IOS-XR-ipv4-bgp-cfg.yang</code></li> <li><code>Cisco-IOS-XR-um-router-bgp-cfg</code></li> </ul> <p>(see <a href="#">GitHub</a>, <a href="#">YANG Data Models Navigator</a>)</p>

## Configure VRF Next Hop Policy

To enable next hop route policy on a VRF table, perform the following steps:

- Configure a route policy and enter route-policy configuration mode.
- Define the route policy to help limit notifications delivered to BGP for specific prefixes.
- Drop the prefix of the routes that matches the conditions set in the route policy.
- Enable BGP routing and enter the router configuration mode.
- Configure a VRF.

- Configure an IPv4 or IPv6 address family.
- Configure route policy filtering using next hops.

```
Router(config)# route-policy nh-route-policy
Router(config-rpl)# if destination in (10.1.1.0/24) and protocol in (connected, static)
then
Router(config-rpl-if)# drop
Router(config-rpl-if)# endif
Router(config-rpl)# end-policy
Router(config-rpl)# exit
Router(config)# router bgp 500
Router(config-bgp)# vrf vrf10
Router(config-bgp-vrf)# address-family ipv4 unicast
Router(config-bgp-vrf-af)# nexthop route-policy nh-route-policy
```

### Running Configuration

```
route-policy nh-route-policy
  if destination in (10.1.1.0/24) and protocol in (connected, static) then
    drop
  endif
end-policy
!

router bgp 500
  vrf vrf10
    address-family ipv4 unicast
      nexthop route-policy nh-route-policy
```

### Verification

Verify that the configured next route hop policy is enabled in a VRF table. The "BGP table nexthop route policy" field indicates the route policy used to determine the next hop for BGP routes in the specified VRF instance VRF1.

```
Router# show bgp vrf vrf1 ipv4 unicast
Fri Jul 7 15:51:16.309 +0530
BGP VRF vrf1, state: Active
BGP Route Distinguisher: 1:1
VRF ID: 0x6000000b
BGP router identifier 10.1.1.1, local AS number 65001
Non-stop routing is enabled
BGP table state: Active
Table ID: 0xe000000b RD version: 1356
BGP table nexthop route policy: nh-route-policy --> This is the same route policy that was
  configured.
BGP main routing table version 1362
BGP NSR Initial initsync version 1355 (Reached)
BGP NSR/ISSU Sync-Group versions 1362/0

Status codes: s suppressed, d damped, h history, * valid, > best
               i - internal, r RIB-failure, S stale, N Nexthop-discard
Origin codes: i - IGP, e - EGP, ? - incomplete
   Network        Next Hop          Metric  LocPrf  Weight Path
Route Distinguisher: 1:1 (default for vrf vrf1)
Route Distinguisher Version: 1356
*> 10.1.1.0/24      0.0.0.0          0        32768  ?
```

```
*> 192.0.2.0/24    10.1.1.1    0    32768  ?  
*> 198.50.100.0/24 10.1.1.1    0           101  i
```