



# Shelf and Backplane Hardware

---



## Note

The terms "Unidirectional Path Switched Ring" and "UPSR" may appear in Cisco literature. These terms do not refer to using Cisco ONS 15xxx products in a unidirectional path switched ring configuration. Rather, these terms, as well as "Path Protected Mesh Network" and "PPMN," refer generally to Cisco's path protection feature, which may be used in any topological network configuration. Cisco does not recommend using its path protection feature in any particular topological network configuration.

---

This chapter provides a description of Cisco ONS 15454 shelf and backplane hardware. Card descriptions are provided in Chapter 2, "Common Control Cards," Chapter 3, "Electrical Cards," Chapter 4, "Optical Cards," Chapter 5, "Ethernet Cards," and Chapter 6, "DWDM Cards." To install equipment, refer to the *Cisco ONS 15454 Procedure Guide*.

Chapter topics include:

- Overview, page 2
- Rack Installation, page 3
- Front Door, page 7
- Backplane Covers, page 11
- Electrical Interface Assemblies, page 15
- Coaxial Cable, page 25
- DS-1 Cable, page 25
- Cable Routing and Management, page 26
- Alarm Expansion Panel, page 29
- Fan-Tray Assembly, page 36
- Power and Ground Description, page 37
- Alarm, Timing, LAN, and Craft Pin Connections, page 38
- Cards and Slots, page 42
- Ferrites, page 46
- Software and Hardware Compatibility, page 46



## Note

The Cisco ONS 15454 assembly is intended for use with telecommunications equipment only.

---

**Warning**

**Only trained and qualified personnel should be allowed to install, replace, or service this equipment.**

**Warning**

**This equipment must be installed and maintained by service personnel as defined by AS/NZS 3260. Incorrectly connecting this equipment to a general purpose outlet could be hazardous. The telecommunications lines must be disconnected 1) before unplugging the main power connector and/or 2) while the front door is open.**

**Warning**

**The ONS 15454 is intended for installation in restricted access areas. A restricted access area is where access can only be gained by service personnel through the use of a special tool, lock, key, or other means of security. A restricted access area is controlled by the authority responsible for the location.**

**Warning**

**The ONS 15454 is suitable for mounting on concrete or other non-combustible surfaces only.**

**Caution**

Unused card slots should be filled with a blank faceplate (Cisco P/N 15454-BLANK). The blank faceplate ensures proper airflow when operating the ONS 15454 without the front door attached, although Cisco recommends that the front door remain attached.

**Note**

The ONS 15454 is designed to comply with GR-1089-CORE Type 2 and Type 4. Install and operate the ONS 15454 only in environments that do not expose wiring or cabling to the outside plant. Acceptable applications include Central Office Environments (COEs), Electronic Equipment Enclosures (EEEs), Controlled Environment Vaults (CEVs), huts, and Customer Premise Environments (CPEs).

**Note**

You can search for cross-referenced Cisco part numbers and CLEI (Common Language Equipment Identification) codes at the following link: [http://www.cisco.com/cgi-bin/front.x/clei/code\\_search.cgi](http://www.cisco.com/cgi-bin/front.x/clei/code_search.cgi)

## 1.1 Overview

When installed in an equipment rack, the ONS 15454 assembly is typically connected to a fuse and alarm panel to provide centralized alarm connection points and distributed power for the ONS 15454. Fuse and alarm panels are third-party equipment and are not described in this documentation. If you are unsure about the requirements or specifications for a fuse and alarm panel, consult the user documentation for the related equipment. The front door of the ONS 15454 allows access to the shelf assembly, fan-tray assembly, and cable-management area. The backplanes provide access to alarm contacts, external interface contacts, power terminals, and BNC/SMB connectors.

**Warning**

**The ONS 15454 relies on the protective devices in the building installation to protect against short circuit, overcurrent, and grounding faults. Ensure that the protective devices are properly rated to protect the system, and that they comply with national and local codes.**

**Warning**

---

**Incorporate a readily-accessible, two-poled disconnect device in the fixed wiring.**

---

You can mount the ONS 15454 in a 19- or 23-inch rack. The shelf assembly weighs approximately 55 pounds with no cards installed. The shelf assembly includes a front door for added security, a fan tray module for cooling, and extensive cable-management space.

ONS 15454 optical cards have SC and LC connectors on the card faceplate. Fiber optic cables are routed into the front of the destination cards. Electrical cards (DS-1, DS-3, DS3XM-6, and EC-1) require electrical interface assemblies (EIAs) to provide the cable connection points for the shelf assembly. In most cases, EIAs are ordered with the ONS 15454 and come pre-installed on the backplane. See the “Electrical Interface Assemblies” section on page 15 for more information about the EIAs.

The ONS 15454 is powered using –48 VDC power. Negative, return, and ground power terminals are accessible on the backplane.

**Note**

---

In this chapter, the terms “ONS 15454” and “shelf assembly” are used interchangeably. In the installation context, these terms have the same meaning. Otherwise, shelf assembly refers to the physical steel enclosure that holds cards and connects power, and ONS 15454 refers to the entire system, both hardware and software.

---

Install the ONS 15454 in compliance with your local and national electrical codes:

- United States: National Fire Protection Association (NFPA) 70; United States National Electrical Code
- Canada: Canadian Electrical Code, Part I, CSA C22.1
- Other countries: If local and national electrical codes, are not available, refer to IEC 364, Part 1 through Part 7.

**Warning**

---

**Dispose of this product according to all national laws and regulations.**

---

## 1.2 Rack Installation

**Warning**

---

**To prevent the equipment from overheating, do not operate it in an area that exceeds the maximum recommended ambient temperature of 131°F (55°C) unless configured for industrial temperature (I-temp). All I-temp rated components are –40°C to +65°C. To prevent airflow restriction, allow at least 1 inch (25.4 mm) of clearance around the ventilation openings.**

---

The ONS 15454 is mounted in a 19- or 23-inch equipment rack. The shelf assembly projects five inches (127 mm) from the front of the rack. It mounts in both EIA-standard and Telcordia-standard racks. The shelf assembly is a total of 17 inches (431.8 mm) wide with no mounting ears attached. Ring runs are not provided by Cisco and may hinder side-by-side installation of shelves where space is limited.

The ONS 15454 measures 18.5 inches (469.9 mm) high, 19 or 23 inches (482.6 or 584.2 mm) wide (depending on which way the mounting ears are attached), and 12 inches (304.8 mm) deep. You can install up to four ONS 15454s in a seven-foot (2133.6 mm) equipment rack. The ONS 15454 must have one inch (25.4 mm) of airspace below the installed shelf assembly to allow air flow to the fan

intake. If a second ONS 15454 is installed underneath the shelf assembly, the air ramp on top of the lower shelf assembly provides the air spacing needed and should not be modified in any way. [Figure 1-1 on page 1-4](#) shows the dimensions of the ONS 15454.

**Note**

The 10 Gbps compatible shelf assembly (15454-SA-ANSI) and fan-tray assembly (15454-FTA3 or 15454-FTA3-T) are required if ONS 15454 XC10G cards are installed in the shelf.

**Warning**

The ONS 15454 should be installed in the lower rack position or mounted above another ONS 15454 shelf assembly.

**Warning**

The ONS 15454 must have 1 inch (25.4 mm) of airspace below the installed shelf assembly to allow air flow to the fan intake. The air ramp (the angled piece of sheet metal on top of the shelf assembly) provides this spacing and should not be modified in any way.

**Figure 1-1 Cisco ONS 15454 Dimensions**

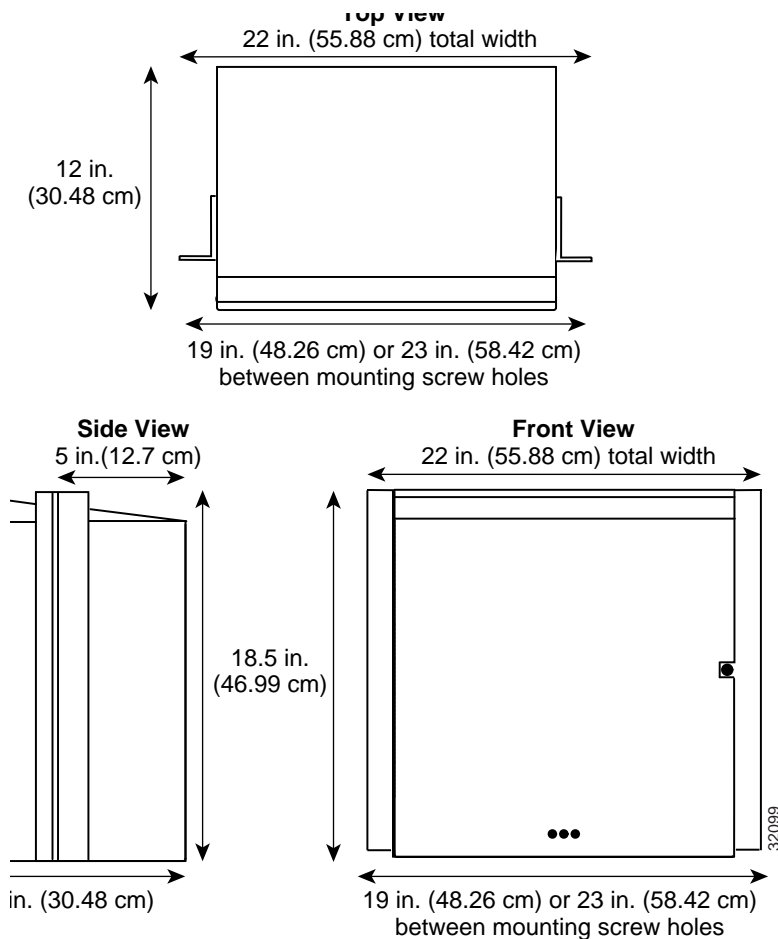

## 1.2.1 Reversible Mounting Bracket



**Caution**

Use only the fastening hardware provided with the ONS 15454 to prevent loosening, deterioration, and electromechanical corrosion of the hardware and joined material.



**Caution**

When mounting the ONS 15454 in a frame with a non-conductive coating (such as paint, lacquer, or enamel) either use the thread-forming screws provided with the ONS 15454 shipping kit, or remove the coating from the threads to ensure electrical continuity.

The shelf assembly comes preset for installation in a 23-inch rack, but you can reverse the mounting bracket to fit the smaller 19-inch rack.

## 1.2.2 Mounting a Single Node

Mounting the ONS 15454 in a rack requires a minimum of 18.5 inches (469.9 mm) of vertical rack space and one additional inch (25.4 mm) for air flow. To ensure the mounting is secure, use two to four #12-24 mounting screws for each side of the shelf assembly. Figure 1-2 shows the rack mounting position for the ONS 15454.

*Figure 1-2 Mounting an ONS 15454 in a Rack*

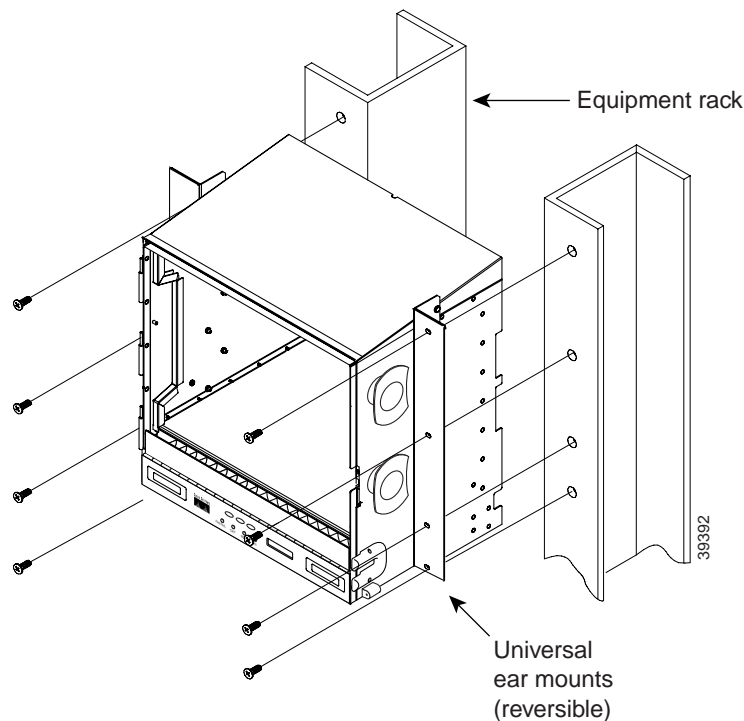

Two people should install the shelf assembly; however, one person can install it using the temporary set screws included. The shelf assembly should be empty for easier lifting. The front door can also be removed to lighten the shelf assembly.

**Note**

If you are installing the fan-tray air filter using the bottom (external) brackets provided, mount the brackets on the bottom of the shelf assembly before installing the ONS 15454 in a rack.

## 1.2.3 Mounting Multiple Nodes

Most standard (GR-63-CORE, 19-inch or 23-inch) seven-foot racks can hold four ONS 15454s and a fuse and alarm panel. However, unequal flange racks are limited to three ONS 15454s and a fuse and alarm panel or four ONS 15454s and a fuse and alarm panel from an adjacent rack.

If you are using the external (bottom) brackets to install the fan-tray air filter, you can install three shelf assemblies in a standard seven-foot rack. If you are not using the external (bottom) brackets, you can install four shelf assemblies in a rack. The advantage to using the bottom brackets is that you can replace the filter without removing the fan tray.

## 1.2.4 ONS 15454 Bay Assembly

The Cisco ONS 15454 Bay Assembly simplifies ordering and installing the ONS 15454 because it allows you to order shelf assemblies pre-installed in a seven-foot rack. The Bay Assembly is available in a three- or four-shelf configuration. The three-shelf configuration includes three ONS 15454 shelf assemblies, a pre-wired fuse and alarm panel, and two cable-management trays. The four-shelf configuration includes four ONS 15454 shelf assemblies and a pre-wired fuse and alarm panel. You can order optional fiber channels with either configuration. Installation procedures are included in the *Unpacking and Installing the Cisco ONS 15454 Four-Shelf and Zero-Shelf Bay Assembly* document that ships with the Bay Assembly.

## 1.2.5 Typical DWDM Rack Layouts

Typical DWDM applications may include:

- 3 ONS 15454 shelves
- 1 DCUs
- 7 Patch Panels (or Fiber Storage tray(s))

Or, alternatively:

- 3 ONS 15454 shelves
- 2 DCUs
- 6 Patch Panels (or Fiber Storage tray(s))

See [Figure 1-3 on page 1-7](#) for a typical rack layout. If you are installing a patch panel or fiber storage tray below the ONS 15454 shelf you must install the air ramp between the shelf and patch panel/fiber tray, or leave one RMU space open.

Figure 1-3 Typical DWDM Equipment Layout

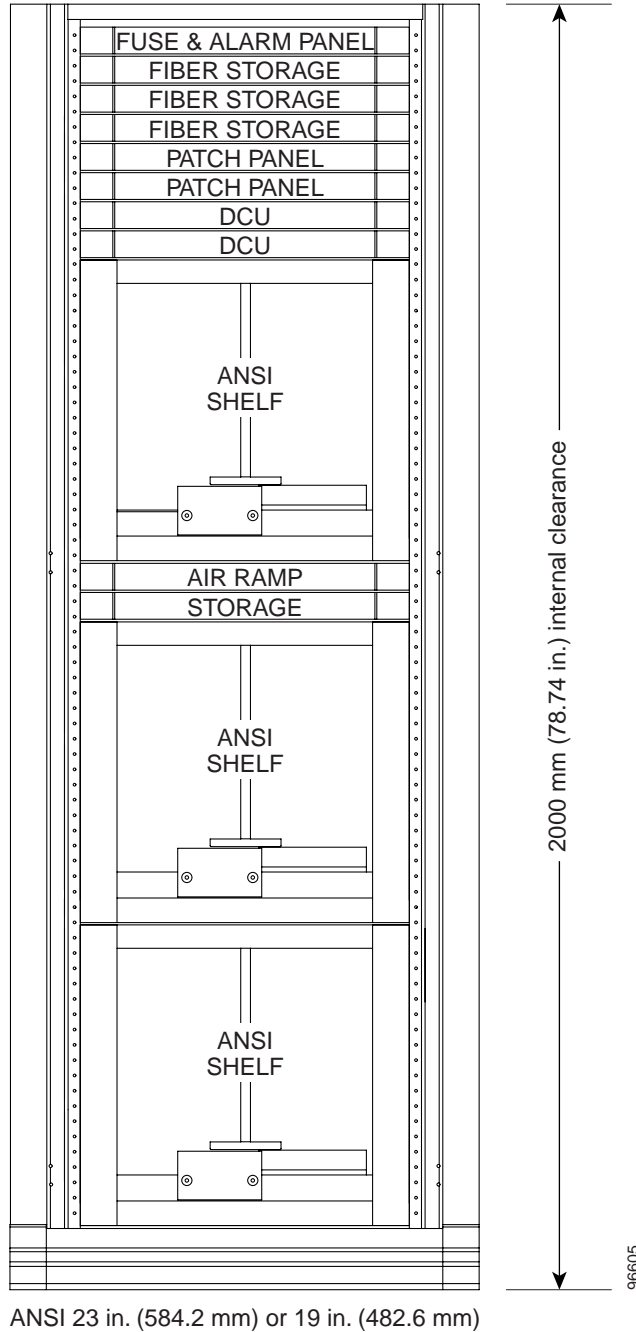

## 1.3 Front Door

The Critical, Major, and Minor alarm LEDs visible through the front door indicate whether a critical, major, or minor alarm is present anywhere on the ONS 15454. These LEDs must be visible so technicians can quickly determine if any alarms are present on the ONS 15454 shelf or the network. You can use the LCD to further isolate alarms.

The ONS 15454 features a locked door to the front compartment. A pinned hex key that unlocks the front door ships with the ONS 15454. A button on the right side of the shelf assembly releases the door. The front door (Figure 1-4) provides access to the shelf assembly, cable-management tray, fan-tray assembly, and LCD screen.

**Figure 1-4** The ONS 15454 Front Door

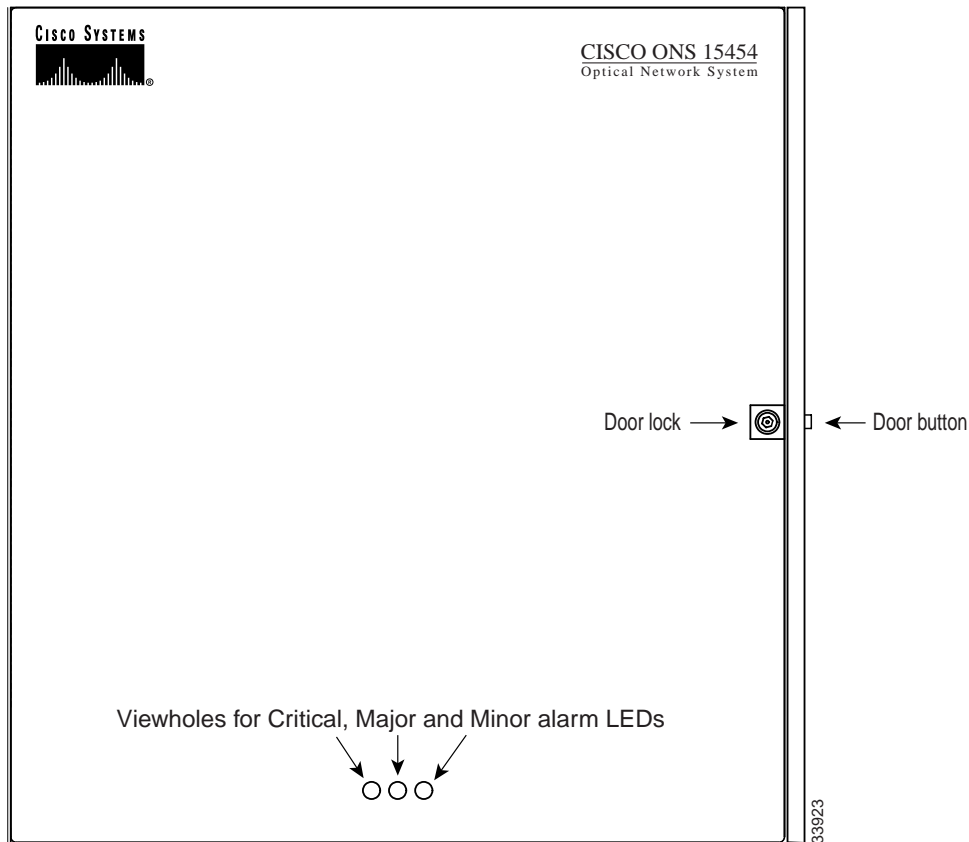

You can remove the front door of the ONS 15454 to provide unrestricted access to the front of the shelf assembly. Before you remove the front door, you have to remove the ground strap of the front door (Figure 1-5 on page 1-9).



Figure 1-5 ONS 15454 Front Door Ground Strap

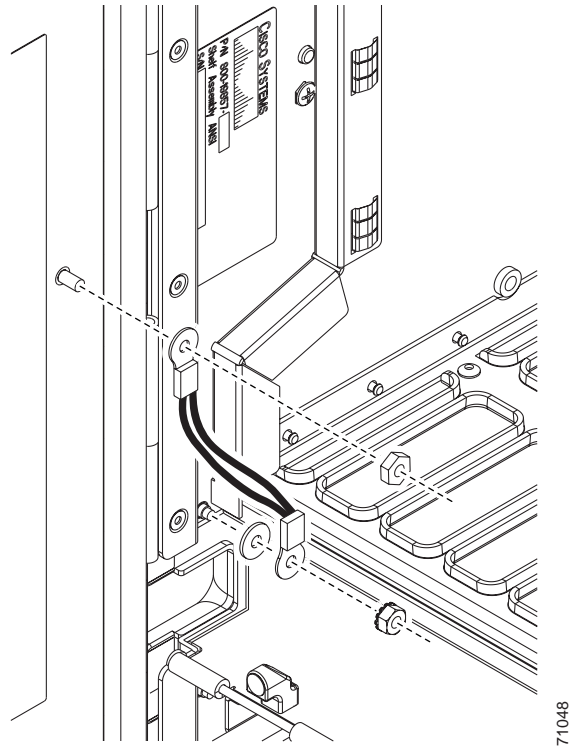
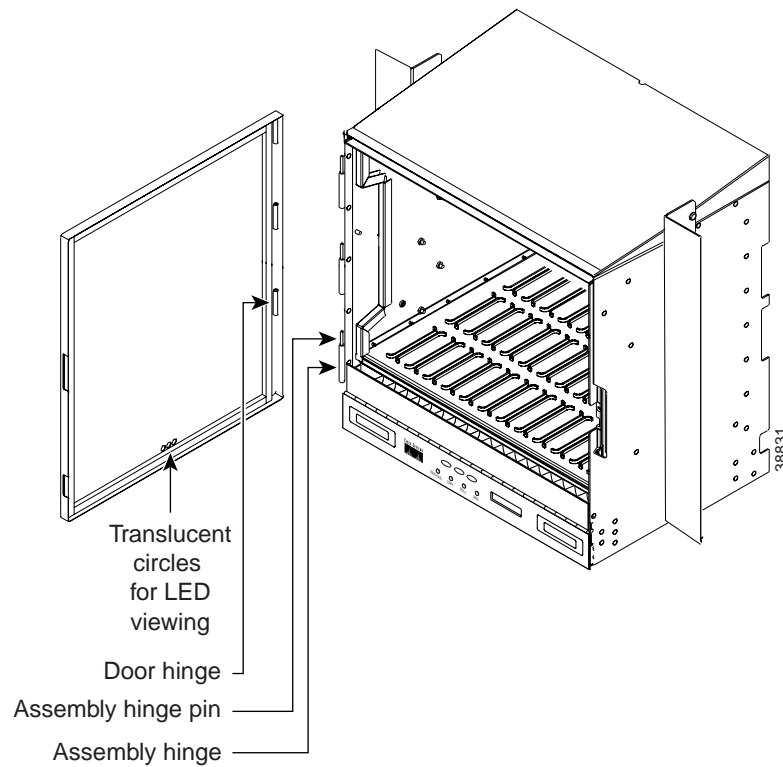

Figure 1-6 on page 1-10 shows how to remove the front door.

**Figure 1-6 Removing the ONS 15454 Front Door**



An erasable label is pasted on the inside of the front door (Figure 1-7 on page 1-11). You can use the label to record slot assignments, port assignments, card types, node ID, rack ID, and serial number for the ONS 15454.

Figure 1-7 Front-Door Erasable Label

		SLOT ASSIGNMENTS																
CARD NAME		1	2	3	4	5	6	7	8	9	10	11	12	13	14	15	16	17
PORT ASSIGNMENTS	1							TCC___	XC___	---	XC___	TCC___						
	2																	
	3																	
	4																	
	5																	
	6																	
	7																	
	8																	
	9																	
	10																	
	11																	
	12																	
	13																	
	14																	
	15																	
	16																	

SHELF ID: \_\_\_\_\_

RACK ID: \_\_\_\_\_

SERIAL #: \_\_\_\_\_

**DANGER**

INVISIBLE RADIATION MAY BE EMITTED FROM OPTICAL CARDS AT THE END OF UNTERMINATED FIBER CABLES OR CONNECTORS. DO NOT STARE INTO THE BEAM OR VIEW DIRECTLY WITH OPTICAL INSTRUMENTS.

**CLASS I - LASER PRODUCT (CDRH)**  
**CLASS 1M LASER PRODUCT (IEC)**

ATTN: TO MAINTAIN FCC EMI COMPLIANCE REPLACE FRONT COVER AFTER SERVICING.

**CAUTION: ELECTROSTATIC SENSITIVE DEVICES**

IP ADDRESS: \_\_\_\_\_

MAC ADDRESS: \_\_\_\_\_

61840

**Note**

The front door label also includes the Class I and Class 1M laser warning (Figure 1-8).

Figure 1-8 Laser Warning on the Front-Door Label

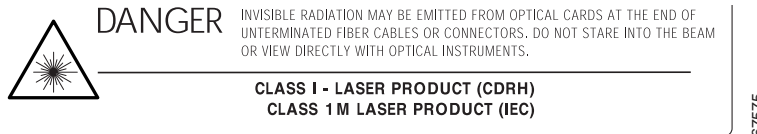

67575

## 1.4 Backplane Covers

If a backplane does not have an EIA panel installed, it should have two sheet metal backplane covers (one on each side of the backplane). See [Figure 1-9 on page 1-12](#). Each cover is held in place with nine 6-32 x 3/8 inch Phillips screws.

**Note**

See the “Electrical Interface Assemblies” section on page 15 for information on EIAs.

Figure 1-9 Backplane Covers

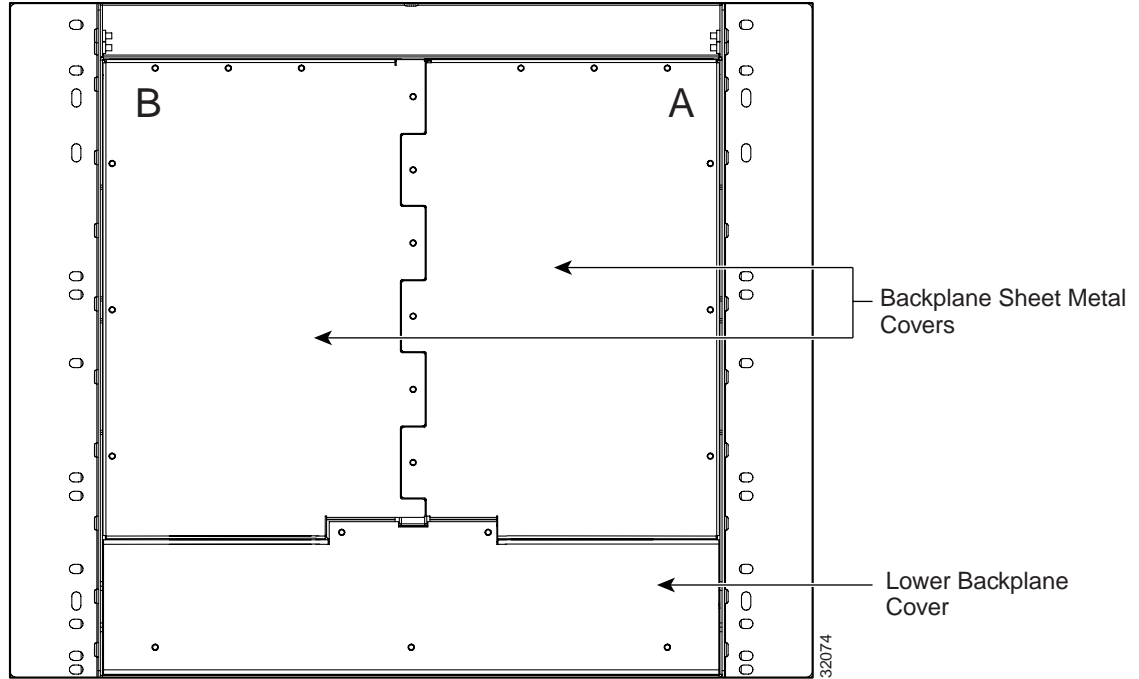

## 1.4.1 Lower Backplane Cover

The lower section of the ONS 15454 backplane is covered by a clear plastic protector, which is held in place by five 6-32 x 1/2 inch screws. Remove the lower backplane cover to access the alarm interface panel (AIP), alarm pin fields, frame ground, and power terminals (Figure 1-10).

Figure 1-10 Removing the Lower Backplane Cover

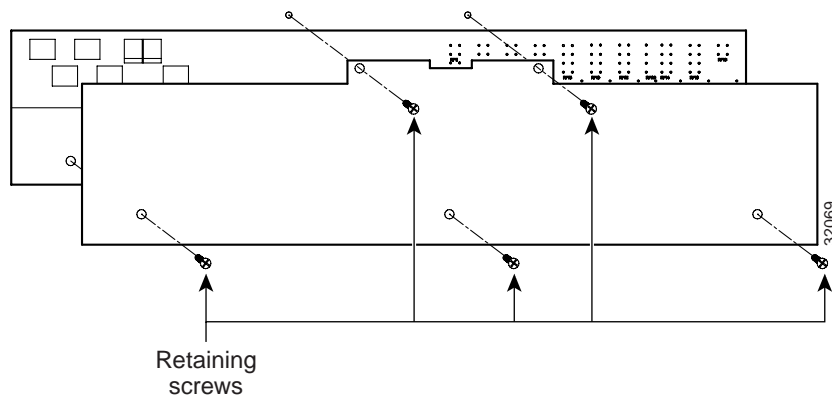

## 1.4.2 Rear Cover

The ONS 15454 has an optional clear plastic rear cover. This clear plastic cover provides additional protection for the cables and connectors on the backplane. Figure 1-11 shows the rear cover screw locations.

*Figure 1-11 Backplane Attachment for Cover*

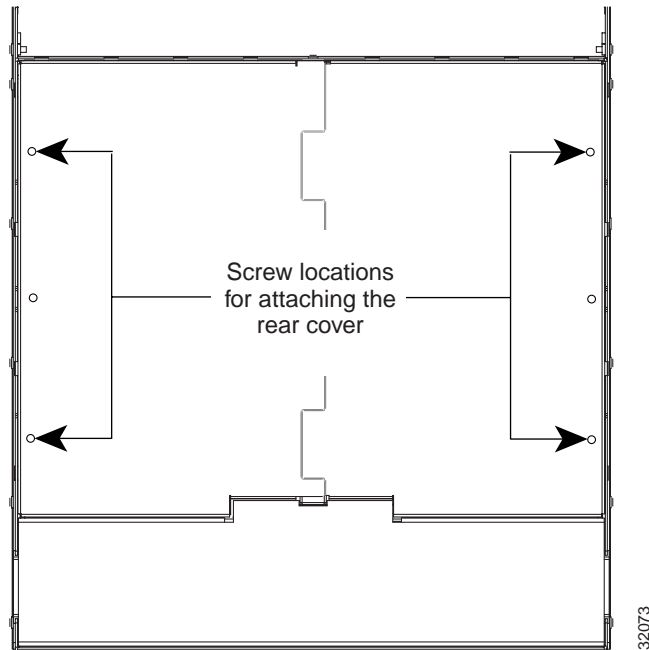

You can also install the optional spacers if more space is needed between the cables and rear cover ([Figure 1-12 on page 1-14](#)).

Figure 1-12 Installing the Plastic Rear Cover with Spacers

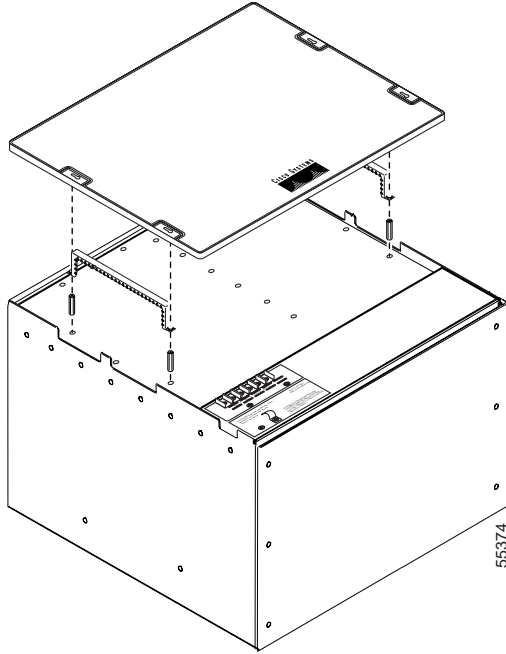

### 1.4.3 Alarm Interface Panel

The AIP is located above the alarm contacts on the lower section of the backplane. The AIP provides surge protection for the ONS 15454. It also provides an interface from the backplane to the fan-tray assembly and LCD. The AIP plugs into the backplane using a 96-pin DIN connector and is held in place with two retaining screws. The panel has a non-volatile memory chip that stores the unique node address (MAC address).



**Note**

The 5-A AIP (73-7665-XX) is required when installing the new fan-tray assembly (15454-FTA3), which comes preinstalled on the shelf assembly (15454-SA-ANSI).



**Note**

The MAC address identifies the nodes that support circuits. It allows CTC to determine circuit sources, destinations, and spans. The TCC+ or TCC2 cards in the ONS 15454 also use the MAC address to store the node database.



**Note**

A blown fuse on the AIP board can cause the LCD display to go blank.

## 1.4.4 Alarm Interface Panel Replacement

If the alarm interface panel (AIP) fails, a MAC Fail alarm displays on the CTC Alarms menu and/or the LCD display on the fan-tray assembly will go blank. To perform an in-service replacement of the AIP, you must contact Cisco Technical Assistance Center (TAC). For contact information, go to the TAC website at <http://www.cisco.com/tac>.

You can replace the AIP on an in-service system without affecting traffic (except Ethernet traffic on nodes running a software release earlier than Release 4.0). The circuit repair feature allows you to repair circuits affected by MAC address changes on one node at a time. Circuit repair will work when all nodes are running the same software version. Each individual AIP upgrade requires an individual circuit repair; if AIPs are replaced on two nodes, the circuit repair must be performed twice.

**Caution**

Do not use a 2-A AIP with a 5-A fan-tray assembly; doing so will cause a blown fuse on the AIP.

**Note**

Ensure that all nodes in the affected network are running the same software version before replacing the AIP and repairing circuits. If you need to upgrade nodes to the same software version, no hardware should be changed or circuit repair performed until after the software upgrade is complete.

**Note**

Replace an AIP during a maintenance window. Resetting the active TCC+/TCC2 can cause a service disruption of less than 50 ms to optical (OC-N) or electrical (DS-N) traffic. Resetting the active TCC+/TCC2 will cause a service disruption of 3 to 5 minutes on all E-Series Ethernet traffic due to spanning tree reconvergence.

## 1.5 Electrical Interface Assemblies

Optional EIA backplane covers are typically pre-installed when ordered with the ONS 15454. EIAs must be ordered when using DS-1, DS-3, DS3XM-6, or EC-1 cards. This section describes each EIA.

Four different EIA backplane covers are available for the ONS 15454: BNC, High-Density BNC, SMB, and AMP Champ. This section describes each EIA in detail. If the shelf was not shipped with the correct EIA interface, you must order and install the correct EIA.

EIAs are attached to the shelf assembly backplane to provide electrical interface cable connections. EIAs are available with SMB and BNC connectors for DS-3 or EC-1 cards. EIAs are available with AMP Champ connectors for DS-1 cards. You must use SMB EIAs for DS-1 twisted-pair cable installation. You can install EIAs on one or both sides of the ONS 15454 backplane in any combination (in other words, AMP Champ on Side A and BNC on Side B or High-Density BNC on side A and SMB on side B, and so forth).

As you face the rear of the ONS 15454 shelf assembly, the right-hand side is the A side and the left-hand side is the B side. The top of the EIA connector columns are labeled with the corresponding slot number, and EIA connector pairs are marked transmit (Tx) and receive (Rx) to correspond to transmit and receive cables.

## 1.5.1 EIA Installation

Optional EIA backplane covers are typically pre-installed when ordered with the ONS 15454. A minimum amount of assembly may be required when EIAs are ordered separately from the ONS 15454. If you are installing EIAs after the shelf assembly is installed, plug the EIA into the backplane. The EIA has six electrical connectors that plug into six corresponding backplane connectors. The EIA backplane must replace the standard sheet metal cover to provide access to the coaxial cable connectors. The EIA sheet metal covers use the same screw holes as the solid backplane panels, but they have 12 additional 6-32 x 1/2 inch Phillips screw holes so you can screw down the cover and the board using standoffs on the EIA board.

When using the RG-179 coaxial cable on an EIA, the maximum distance available (122 feet) is less than the maximum distance available with standard RG-59 (735A) cable (306 feet). The maximum distance when using the RG-59 (734A) cable is 450 feet. The shorter maximum distance available with the RG179 is due to a higher attenuation rate for the thinner cable. Attenuation rates are calculated using a DS-3 signal:

- For RG-179, the attenuation rate is 59 dB/kft at 22 MHz.
- For RG-59 (735A) the attenuation rate is 23 dB/kft at 22 MHz.

## 1.5.2 EIA Configurations

Table 1-1 gives the product numbers and common names for EIAs.

**Table 1-1** EIA Configurations

EIA Type	Cards Supported	A Side Hosts	A Side Columns Map to	A Side Product Number	B Side Hosts	B Side Columns Map to	B Side Product Number
BNC	DS-3 DS3XM-6 EC-1	24 pairs of BNC connectors	Slot 2 Slot 4	15454-EIA-BNC-A24	24 pairs of BNC connectors	Slot 14 Slot 16	15454-EIA-BNC-B24
High-Density BNC	DS-3 DS3XM-6 EC-1	48 pairs of BNC connectors	Slot 1 Slot 2 Slot 4 Slot 5	15454-EIA-BNC-A48	48 pairs of BNC connectors	Slot 13 Slot 14 Slot 16 Slot 17	15454-EIA-BNC-B48



Table 1-1 EIA Configurations (continued)

EIA Type	Cards Supported	A Side Hosts	A Side Columns Map to	A Side Product Number	B Side Hosts	B Side Columns Map to	B Side Product Number
SMB	DS-1 DS-3 EC-1 DS3XM-6	84 pairs of SMB connectors	Slot 1 Slot 2 Slot 3 Slot 4 Slot 5 Slot 6	15454-EIA-SMB-A84	84 pairs of SMB connectors	Slot 12 Slot 13 Slot 14 Slot 15 Slot 16 Slot 17	15454-EIA-SMB-B84
AMP Champ	DS-1	6 AMP Champ connectors	Slot 1 Slot 2 Slot 3 Slot 4 Slot 5 Slot 6	15454-EIA-AMP-A84	6 AMP Champ connectors	Slot 12 Slot 13 Slot 14 Slot 15 Slot 16 Slot 17	15454-EIA-AMP-B84

### 1.5.3 BNC EIA

The ONS 15454 BNC EIA supports 24 DS-3 circuits on each side of the ONS 15454 (24 transmit and 24 receive connectors). If you install BNC EIAs on both sides of the shelf assembly, the ONS 15454 hosts up to 48 circuits. The BNC connectors on the EIA supports Trompeter UCBJ224 (75 ohm) 4 leg connectors (King or ITT are also compatible). Right-angle mating connectors for the connecting cable are AMP 413588-2 (75 Ohm) connectors. If preferred, you can also use a straight connector of the same type. Use RG-59/U cable to connect to the ONS 15454 BNC EIA. These cables are recommended to connect to a patch panel and are designed for long runs. You can use BNC EIAs for DS-3 (including the DS3XM-6) or EC-1 cards.

Figure 1-13 shows the ONS 15454 with pre-installed BNC EIAs.

To install coaxial cable with BNC connectors, refer to the *Cisco ONS 15454 Procedure Guide*.

Figure 1-13 BNC Backplane for use in 1:1 Protection Schemes

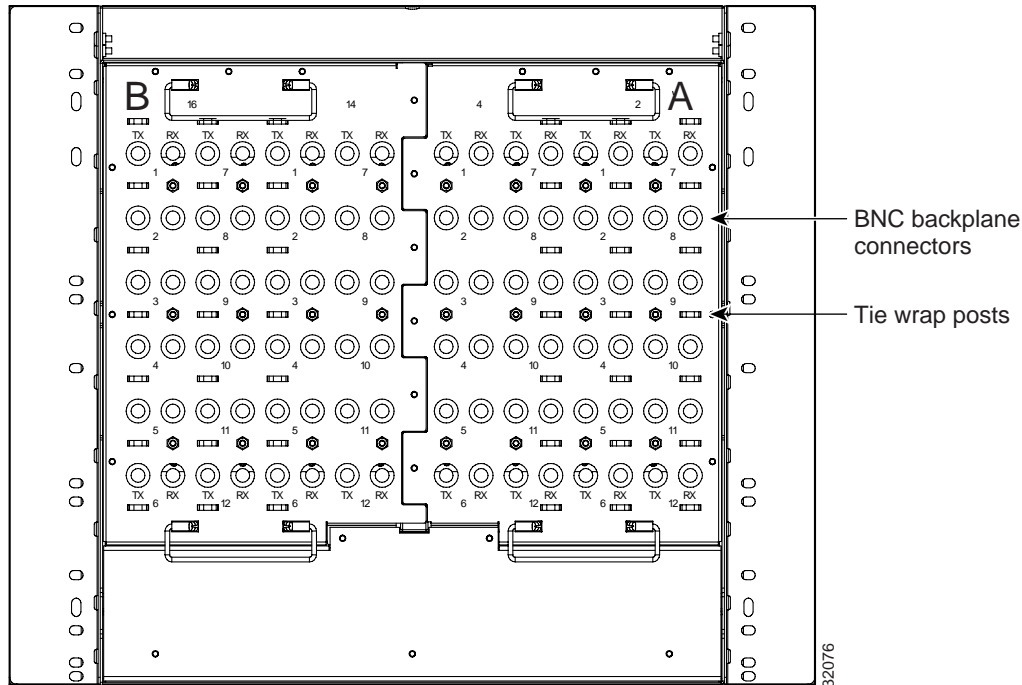

### 1.5.3.1 BNC Connectors

The EIA side marked “A” has 24 pairs of BNC connectors. The first 12 pairs of BNC connectors correspond to Ports 1 to 12 for a 12-port card and map to Slot 2 on the shelf assembly. The BNC connector pairs are marked “Tx” and “Rx” to indicate transmit and receive cables for each port. You can install an additional card in Slot 1 as a protect card for the card in Slot 2. The second 12 BNC connector pairs correspond to Ports 1 to 12 for a 12-port card and map to Slot 4 on the shelf assembly. You can install an additional card in Slot 3 as a protect card for the card in Slot 4. Slots 5 and 6 do not support DS-3 cards when the standard BNC EIA panel connectors are used.

The EIA side marked “B” provides an additional 24 pairs of BNC connectors. The first 12 BNC connector pairs correspond to Ports 1 to 12 for a 12-port card and map to Slot 14 on the shelf assembly. The BNC connector pairs are marked “Tx” and “Rx” to indicate transmit and receive cables for each port. You can install an additional card in Slot 15 as a protect card for the card in Slot 14. The second 12 BNC connector pairs correspond to Ports 1 to 12 for a 12-port card and map to Slot 16 on the shelf assembly. You can install an additional card in Slot 17 as a protect card for the card in Slot 16. Slots 12 and 13 do not support DS-3 cards when the standard BNC EIA panel connectors are used.

When BNC connectors are used with a DS3N-12 card in Slot 3 or 15, the 1:N card protection extends only to the two slots adjacent to the 1:N card due to BNC wiring constraints.

### 1.5.3.2 BNC Insertion and Removal Tool

Due to the large number of BNC connectors on the High-Density BNC EIA, you might require a special tool for inserting and removing BNC EIAs (Figure 1-14). This tool also helps with ONS 15454 patch panel connections.

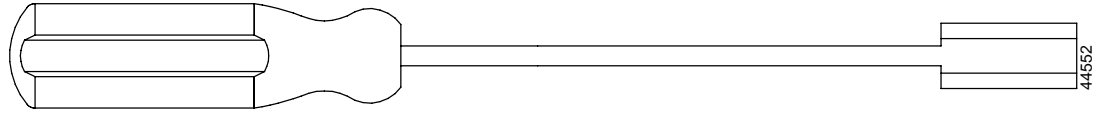
**Figure 1-14 BNC Insertion and Removal Tool**

This tool can be obtained with P/N 227-T1000 from:

Amphenol USA ([www.amphenol.com](http://www.amphenol.com))  
One Kennedy Drive  
Danbury, CT 06810  
Phone: 203-743-9272 Fax: 203-796-2032

This tool can be obtained with P/N RT-1L from:

Trompeter Electronics Inc. ([www.trompeter.com](http://www.trompeter.com))  
31186 La Baya Drive  
Westlake Village, CA 91362-4047  
Phone: (800) 982-2629 Fax: (818) 706-1040

## 1.5.4 High-Density BNC EIA

The ONS 15454 high-density BNC EIA supports 48 DS-3 circuits on each side of the ONS 15454 (48 transmit and 48 receive connectors). If you install BNC EIAs on both sides of the unit, the ONS 15454 hosts up to 96 circuits. The high-density BNC EIA supports Trompeter UCBJ224 (75 ohm) 4 leg connectors (King or ITT are also compatible). Use straight connectors on RG-59/U cable to connect to the high-density BNC EIA. Cisco recommends these cables for connection to a patch panel; they are designed for long runs. You can use high-density BNC EIAs for DS-3 (including the DS3XM-6) or EC-1 cards. [Figure 1-15 on page 1-20](#) shows the ONS 15454 with pre-installed high-density BNC EIAs.

To install coaxial cable with high-density BNC connectors, refer to the *Cisco ONS 15454 Procedure Guide*.

Figure 1-15 High-Density BNC Backplane for use in 1:N Protection Schemes

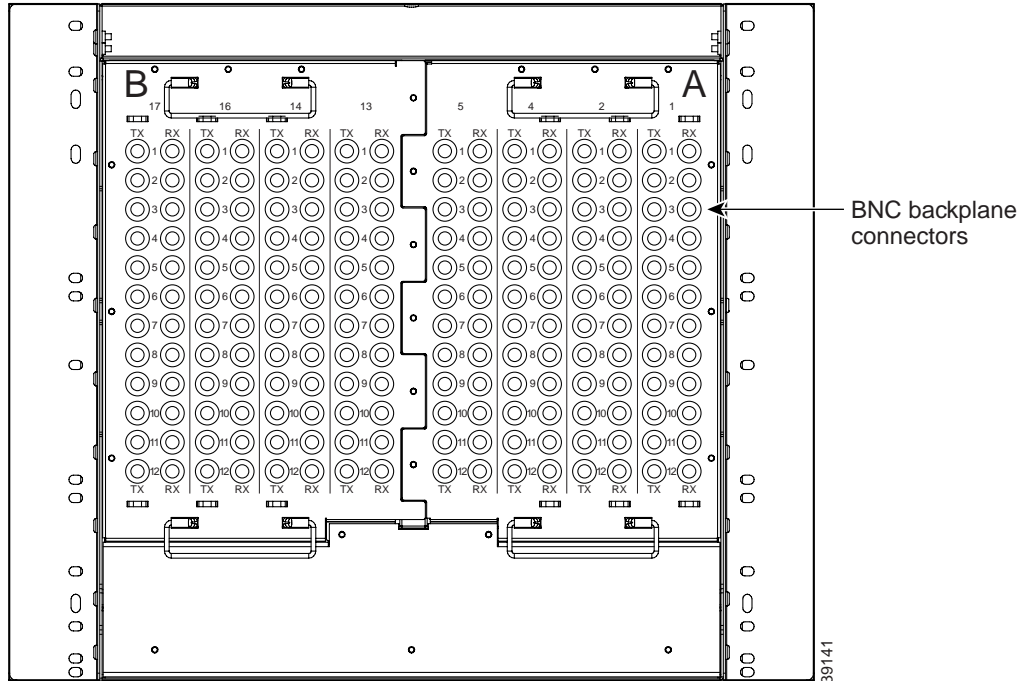

The EIA side marked “A” hosts 48 pairs of BNC connectors. Each column of connector pairs is numbered and corresponds to the slot of the same number. The first column (12 pairs) of BNC connectors corresponds to Slot 1 on the shelf assembly, the second column to Slot 2, the third column to Slot 4, and the fourth column to Slot 5. The rows of connectors correspond to Ports 1 to 12 of a 12-port card.

The EIA side marked “B” provides an additional 48 pairs of BNC connectors. The first column (12 pairs) of BNC connectors corresponds to Slot 13 on the shelf assembly, the second column to Slot 14, the third column to Slot 16, and the fourth column to Slot 17. The rows of connectors correspond to Ports 1 to 12 of a 12-port card. The BNC connector pairs are marked “Tx” and “Rx” to indicate transmit and receive cables for each port. The High-Density BNC EIA supports both 1:1 and 1:N protection across all slots except Slots 6 and 12.

## 1.5.5 SMB EIA

The ONS 15454 SMB EIA supports AMP 415484-1 75 ohm 4 leg connectors. Right-angle mating connectors for the connecting cable are AMP 415484-2 (75 ohm) connectors. Use RG-179/U cable to connect to the ONS 15454 EIA. Cisco recommends these cables for connection to a patch panel; they are not designed for long runs. Range does not affect loopback testing.

You can use SMB EIAs with DS-1, DS-3 (including the DS3XM-6), and EC-1 cards. If you use DS-1 cards, use the DS-1 electrical interface adapter (balun) to terminate the twisted pair DS-1 cable to the SMB EIA (see the “Electrical Interface Adapters” section on page 25). SMB EIAs support 14 ports per slot when used with a DS-1 card, 12 ports per slot when used with a DS-3 or EC-1 card, and 6 ports per slot when used with a DS3XM-6 card.

Figure 1-16 on page 1-21 shows the ONS 15454 with pre-installed SMB EIAs and the sheet metal cover and screw locations for the EIA. The SMB connectors on the EIA are AMP 415504-3 (75 ohm) 4 leg connectors.

To install SMB connectors, refer to the *Cisco ONS 15454 Procedure Guide*.

**Figure 1-16 SMB EIA Backplane**

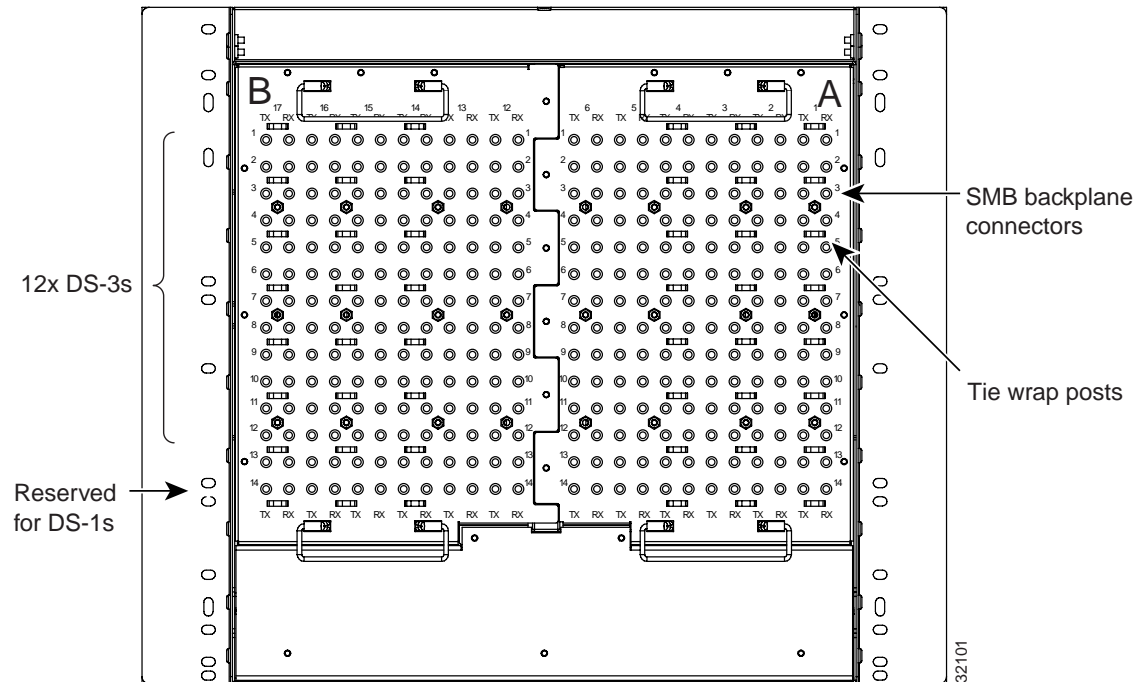

The SMB EIA has 84 transmit and 84 receive connectors on each side of the ONS 15454 for a total of 168 SMB connectors (84 circuits).

The EIA side marked “A” hosts 84 SMB connectors in six columns of 14 connectors. The “A” side columns are numbered 1 to 6 and correspond to Slots 1 to 6 on the shelf assembly. The EIA side marked “B” hosts an additional 84 SMB connectors in six columns of 14 connectors. The “B” side columns are numbered 12 to 17 and correspond to Slots 12 to 17 on the shelf assembly. The connector rows are numbered 1 to 14 and correspond to the 14 ports on a DS-1 card.

For DS-3 or EC-1, the EIA supports 72 transmit and 72 receive connectors, for a total of 144 SMB connectors (72 circuits). If you use a DS-3 or EC-1 card, only Ports 1 to 12 are active. If you use a DS3XM-6 card, only Ports 1 to 6 are active. The SMB connector pairs are marked “Tx” and “Rx” to identify transmit and receive cables for each port. If you use SMB connectors, you can install DS-1, DS-3, or EC-1 cards in any multispeed slot (Slots 1 to 4 or 14 to 17).

## 1.5.6 AMP Champ EIA

The ONS 15454 AMP Champ EIA supports 64-pin (32 pair) AMP Champ connectors for each slot on both sides of the shelf assembly where the EIA is installed. Cisco AMP Champ connectors are female AMP # 552246-1 with AMP # 552562-2 bail locks. Each AMP Champ connector supports 14 DS-1 ports. You can use AMP Champ EIAs with DS-1 cards only. [Figure 1-17 on page 1-22](#) shows the ONS 15454 with pre-installed AMP Champ EIAs and the corresponding sheet metal cover and screw locations for the EIA.

To install AMP Champ connector DS-1 cables, you must use 64-pin bundled cable connectors with a 64-pin male AMP Champ connector. You need an AMP Champ connector #552276-1 for the receptacle side and #1-552496-1 (for cable diameter .475in.–.540in.) or #2-552496-1 (for cable diameter

.540in.–.605in.) for the right-angle shell housing (or their functional equivalent). The corresponding 64-pin female AMP Champ connector on the AMP Champ EIA supports one receive and one transmit for each DS-1 port for the corresponding card slot.

Because each DS1-14 card supports 14 DS-1 ports, only 56 pins (28 pairs) of the 64-pin connector are used. Prepare one 56-wire cable for each DS-1 facility installed.

**Figure 1-17 AMP Champ EIA Backplane**

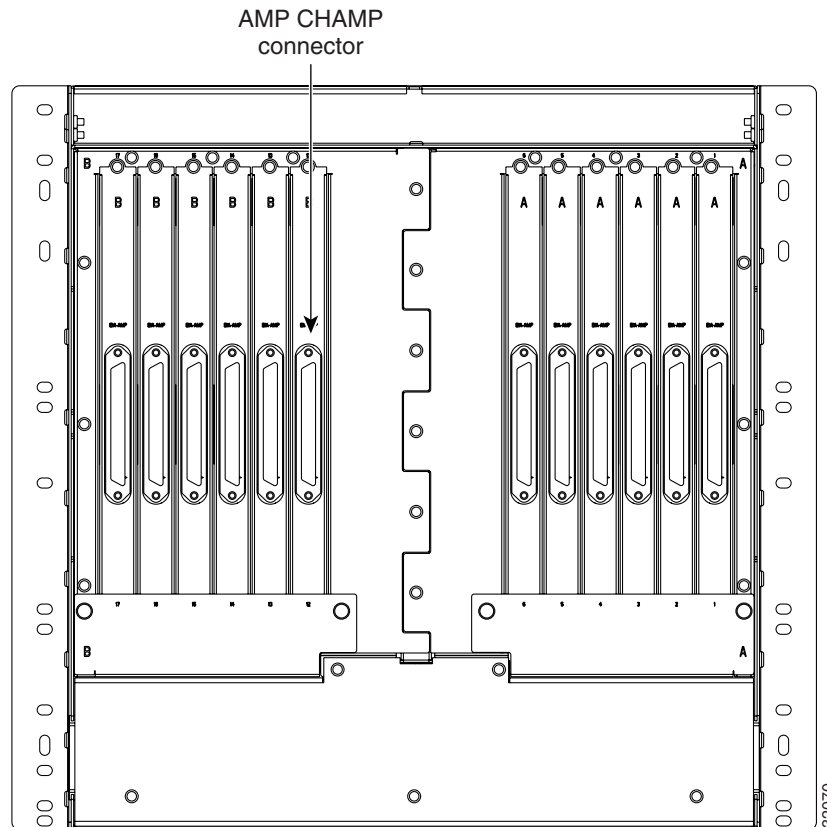

Table 1-2 on page 1-23 shows the pin assignments for the AMP Champ connectors on the ONS 15454 AMP Champ EIA. The EIA side marked “A” hosts six AMP Champ connectors. The connectors are numbered 1 to 6 for the corresponding slots on the shelf assembly. Each AMP Champ connector on the backplane supports 14 DS-1 ports for a DS1-14 card, and each connector features 28 live pairs—one transmit pair and one receive pair—for each DS-1 port.

The EIA side marked “B” hosts six AMP Champ connectors. The connectors are labeled 12 to 17 for the corresponding slots on the shelf assembly. Each AMP Champ connector on the backplane supports 14 DS-1 ports for a DS1-14 card, and each connector features 28 live pairs—one transmit pair and one receive pair—for each DS-1 port.



**Note**

EIAs are hot-swappable. You do not need to disconnect power to install or remove EIAs.



**Caution**

Always use an electrostatic discharge (ESD) wristband when working with a powered ONS 15454. Plug the wristband cable into the ESD jack located on the lower-right outside edge of the shelf assembly.

**Table 1-2 AMP Champ Connector Pin Assignments**

Signal/Wire	Pin	Pin	Signal/Wire	Signal/Wire	Pin	Pin	Signal/Wire
Tx Tip 1 white/blue	1	33	Tx Ring 1 blue/white	Rx Tip 1 yellow/orange	17	49	Rx Ring 1 orange/yellow
Tx Tip 2 white/orange	2	34	Tx Ring 2 orange/white	Rx Tip 2 yellow/green	18	50	Rx Ring 2 green/yellow
Tx Tip 3 white/green	3	35	Tx Ring 3 green/white	Rx Tip 3 yellow/brown	19	51	Rx Ring 3 brown/yellow
Tx Tip 4 white/brown	4	36	Tx Ring 4 brown/white	Rx Tip 4 yellow/slate	20	52	Rx Ring 4 slate/yellow
Tx Tip 5 white/slate	5	37	Tx Ring 5 slate/white	Rx Tip 5 violet/blue	21	53	Rx Ring 5 blue/violet
Tx Tip 6 red/blue	6	38	Tx Ring 6 blue/red	Rx Tip 6 violet/orange	22	54	Rx Ring 6 orange/violet
Tx Tip 7 red/orange	7	39	Tx Ring 7 orange/red	Rx Tip 7 violet/green	23	55	Rx Ring 7 green/violet
Tx Tip 8 red/green	8	40	Tx Ring 8 green/red	Rx Tip 8 violet/brown	24	56	Rx Ring 8 brown/violet
Tx Tip 9 red/brown	9	41	Tx Ring 9 brown/red	Rx Tip 9 violet/slate	25	57	Rx Ring 9 slate/violet
Tx Tip 10 red/slate	10	42	Tx Ring 10 slate/red	Rx Tip 10 white/blue	26	58	Rx Ring 10 blue/white
Tx Tip 11 black/blue	11	43	Tx Ring 11 blue/black	Rx Tip 11 white/orange	27	59	Rx Ring 11 orange/white
Tx Tip 12 black/orange	12	44	Tx Ring 12 orange/black	Rx Tip 12 white/green	28	60	Rx Ring 12 green/white
Tx Tip 13 black/green	13	45	Tx Ring 13 green/black	Rx Tip 13 white/brown	29	61	Rx Ring 13 brown/white
Tx Tip 14 black/brown	14	46	Tx Ring 14 brown/black	Rx Tip 14 white/slate	30	62	Rx Ring 14 slate/white
Tx Spare0+ N/A	15	47	Tx Spare0- N/A	Rx Spare0+ N/A	31	63	Rx Spare0- N/A
Tx Spare1+ N/A	16	48	Tx Spare1- N/A	Rx Spare1+ N/A	32	64	Rx Spare1- N/A

Table 1-3 shows the pin assignments for the AMP Champ connectors on the ONS 15454 AMP Champ EIA for a shielded DS-1 cable.

**Table 1-3 AMP Champ Connector Pin Assignments (Shielded DS-1 Cable)**

64-Pin Blue Bundle				64-Pin Orange Bundle			
Signal/Wire	Pin	Pin	Signal/Wire	Signal/Wire	Pin	Pin	Signal/Wire
Tx Tip 1 white/blue	1	33	Tx Ring 1 blue/white	Rx Tip 1 white/blue	17	49	Rx Ring 1 blue/white
Tx Tip 2 white/orange	2	34	Tx Ring 2 orange/white	Rx Tip 2 white/orange	18	50	Rx Ring 2 orange/white

**Table 1-3 AMP Champ Connector Pin Assignments (Shielded DS-1 Cable) (continued)**

64-Pin Blue Bundle				64-Pin Orange Bundle			
Signal/Wire	Pin	Pin	Signal/Wire	Signal/Wire	Pin	Pin	Signal/Wire
Tx Tip 3 white/green	3	35	Tx Ring 3 green/white	Rx Tip 3 white/green	19	51	Rx Ring 3 green/white
Tx Tip 4 white/brown	4	36	Tx Ring 4 brown/white	Rx Tip 4 white/brown	20	52	Rx Ring 4 brown/white
Tx Tip 5 white/slate	5	37	Tx Ring 5 slate/white	Rx Tip 5 white/slate	21	53	Rx Ring 5 slate/white
Tx Tip 6 red/blue	6	38	Tx Ring 6 blue/red	Rx Tip 6 red/blue	22	54	Rx Ring 6 blue/red
Tx Tip 7 red/orange	7	39	Tx Ring 7 orange/red	Rx Tip 7 red/orange	23	55	Rx Ring 7 orange/red
Tx Tip 8 red/green	8	40	Tx Ring 8 green/red	Rx Tip 8 red/green	24	56	Rx Ring 8 green/red
Tx Tip 9 red/brown	9	41	Tx Ring 9 brown/red	Rx Tip 9 red/brown	25	57	Rx Ring 9 brown/red
Tx Tip 10 red/slate	10	42	Tx Ring 10 slate/red	Rx Tip 10 red/slate	26	58	Rx Ring 10 slate/red
Tx Tip 11 black/blue	11	43	Tx Ring 11 blue/black	Rx Tip 11 black/blue	27	59	Rx Ring 11 blue/black
Tx Tip 12 black/orange	12	44	Tx Ring 12 orange/black	Rx Tip 12 black/orange	28	60	Rx Ring 12 orange/black
Tx Tip 13 black/green	13	45	Tx Ring 13 green/black	Rx Tip 13 black/green	29	61	Rx Ring 13 green/black
Tx Tip 14 black/brown	14	46	Tx Ring 14 brown/black	Rx Tip 14 black/brown	30	62	Rx Ring 14 brown/black
Tx Tip 15 black/slate	15	47	Tx Tip 15 slate/black	Rx Tip 15 black/slate	31	63	Rx Tip 15 slate/black
Tx Tip 16 yellow/blue	16	48	Tx Tip 16 blue/yellow	Rx Tip 16 yellow/blue	32	64	Rx Tip 16 blue/yellow

When using DS-1 AMP Champ cables, you must equip the ONS 15454 with an AMP Champ connector EIA on each side of the backplane where DS-1 cables will terminate. Each AMP Champ connector on the EIA corresponds to a slot in the shelf assembly and is numbered accordingly. The AMP Champ connectors have screw-down tooling at each end of the connector.

## 1.5.7 EIA Replacement

The replacement procedure is the same for all the EIA types. However, installing the AMP Champ EIA requires the additional step of attaching the fastening plate to the bottom of the connector row. Before you attach a new EIA, you must remove the backplane cover or EIA already attached to the ONS 15454.



## 1.6 Coaxial Cable

**Caution**

Always use the supplied ESD wristband when working with a powered ONS 15454. Plug the wristband cable into the ESD jack located on the lower-right outside edge of the shelf assembly.

When using ONS 15454 DS-3 electrical cables, the cables must terminate on an EIA installed on the ONS 15454 backplane. All DS-3 cables connected to the ONS 15454 DS-3 card must terminate with coaxial cables using the desired connector type to connect to the specified EIA.

The electromagnetic compatibility (EMC) performance of the node depends on good-quality DS-3 coaxial cables, such as Shuner Type G 03233 D, or the equivalent.

## 1.7 DS-1 Cable

DS-1 cables support AMP Champ connectors and twisted-pair wire-wrap cabling. Twisted-pair wire-wrap cables require SMB EIAs.

### 1.7.1 Twisted Pair Wire-Wrap Cables

Installing twisted-pair, wire-wrap DS-1 cables requires separate pairs of grounded twisted-pair cables for receive (in) and transmit (out). Prepare four cables, two for receive and two for transmit, for each DS-1 facility to be installed.

**Caution**

Always use the supplied ESD wristband when working with a powered ONS 15454. Plug the wristband cable into the ESD jack located on the lower-right outside edge of the shelf assembly.

If you use DS-1 electrical twisted-pair cables, equip the ONS 15454 with an SMB EIA on each side of the backplane where DS-1 cables will terminate. You must install special DS-1 electrical interface adapters, commonly referred to as a balun, on every transmit and receive connector for each DS-1 termination.

### 1.7.2 Electrical Interface Adapters

**Note**

DS-1 electrical interface adapters project an additional 1.72 inches (43.7 mm) from the ONS 15454 backplane.

If you install DS-1 cards in the ONS 15454, you must fit the corresponding transmit and receive SMB connectors on the EIA with a DS-1 electrical interface adapter. You can install the adapter on the SMB connector for the port. The adaptor has wire-wrap posts for DS-1 transmit and receive cables.

[Figure 1-18 on page 1-26](#) shows the DS-1 electrical interface adapter.

**Note**

“EIA” refers to electrical interface assemblies and not electrical interface adapters. Electrical interface adapters are also known as baluns.

Figure 1-18 DS-1 Electrical Interface Adapter (Balun)

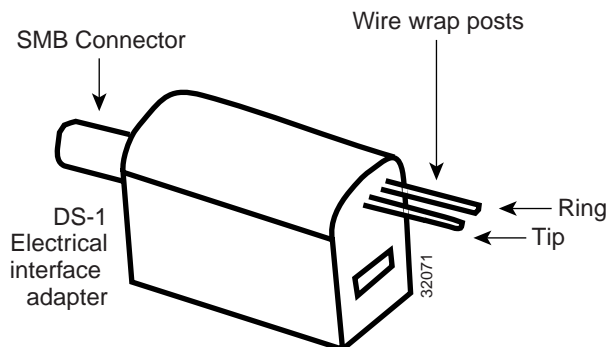

Each DS-1 electrical interface adapter has a female SMB connector on one end and a pair of 0.045 inch (1.14 mm) square wire-wrap posts on the other end. The wire-wrap posts are 0.200 inches (5.08 mm) apart.



**Caution**

Always use the supplied ESD wristband when working with a powered ONS 15454. Plug the wristband cable into the ESD jack located on the lower-right outside edge of the shelf assembly.

## 1.8 Cable Routing and Management

The ONS 15454 cable management facilities include the following:

- A cable-routing channel (behind the fold-down door) that runs the width of the shelf assembly, [Figure 1-19 on page 1-27](#)
- Plastic horseshoe-shaped fiber guides at each side opening of the cable-routing channel that ensure the proper bend radius is maintained in the fibers, [Figure 1-20 on page 1-27](#)



**Note**

You can remove the fiber guide if necessary to create a larger opening (if you need to route CAT-5 Ethernet cables out the side, for example). To remove the fiber guide, take out the three screws that anchor it to the side of the shelf assembly.

- A fold-down door that provides access to the cable-management tray
- Cable tie-wrap facilities on EIAs that secure cables to the cover panel
- Reversible jumper routing fins that enable you to route cables out either side by positioning the fins as desired
- Jumper slack storage reels (2) on each side panel that reduce the amount of slack in cables that are connected to other devices



**Note**

To remove the jumper slack storage reels, take out the screw in the center of each reel.

- Optional Fiber management tray (recommended for DWDM nodes)

[Figure 1-19 on page 1-27](#) shows the cable management facilities that you can access through the fold-down front door, including the cable-routing channel and the jumper routing fins.

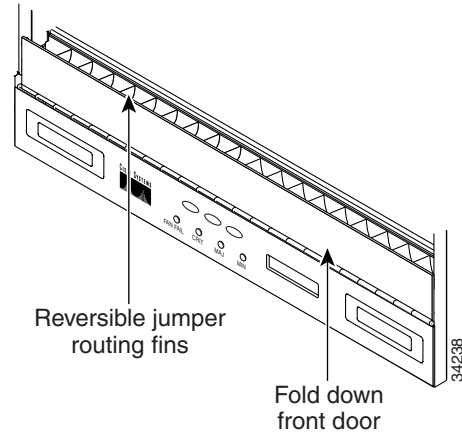
**Figure 1-19 Managing Cables on the Front Panel**

## 1.8.1 Fiber Management

The jumper routing fins are designed to route fiber jumpers out of both sides of the shelf. Slots 1 to 6 exit to the left, and slots 12 to 17 exit to the right. Figure 1-20 shows fibers routed from cards in the left slots, down through the fins, then exiting out the fiber channel to the left. The maximum capacity of the fiber routing channel depends on the size of the fiber jumpers. Table 1-4 on page 1-28 gives the maximum capacity of the fiber channel for each side of the shelf, for the different fiber sizes.

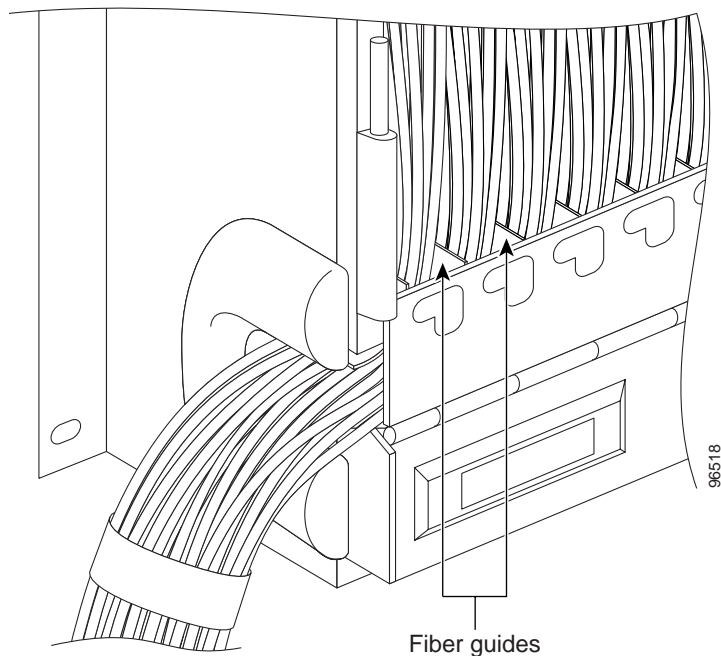
**Figure 1-20 Fiber Capacity**

**Table 1-4 Fiber Capacity**

Fiber Diameter	Maximum Number of Fibers Exiting Each Side
1.6 mm	224
2 mm	144
3 mm	64

Plan your fiber size according to the number of cards/ports installed in each side of the shelf. For example, if your port combination requires 36 fibers, 3 mm fiber is adequate. If your port combination requires 68 fibers, you must use 2 mm or smaller fibers.

## 1.8.2 Fiber Boots

The fiber boot, shown in [Figure 1-21 on page 1-28](#), serves to hold the fiber cable bend radius in a non flexible position. The fiber boot is a rigid plastic sleeve with circular slots that allow you to insert the fiber boot over the fiber cable, and position over the strain relief shroud, next to the cable connector.

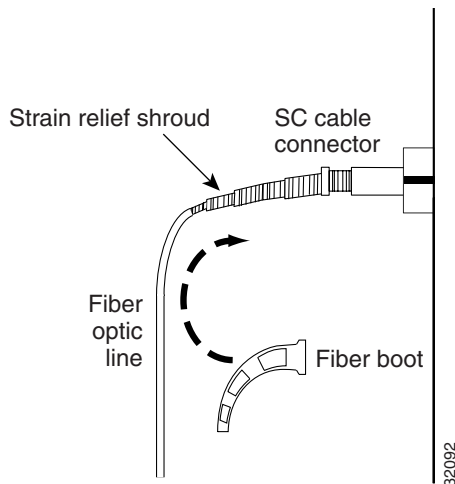
**Figure 1-21 Fiber boot**

## 1.8.3 Fiber Management using the Optional DWDM Fiber Tray

Cisco recommends installing a fiber storage tray in multi-node racks to facilitate fiber management for DWDM applications. Refer to [Figure 1-3 on page 1-7](#) for typical mounting locations.

The fiber capacity for each tray is listed in Table 1-5.

**Table 1-5 Fiber Tray Capacity**

Fiber Diameter	Maximum Number of Fibers Exiting Each Side
1.6 mm	62

*Table 1-5 Fiber Tray Capacity (continued)*

Fiber Diameter	Maximum Number of Fibers Exiting Each Side
2 mm	48
3 mm	32

## 1.8.4 Coaxial Cable Management

Coaxial cables connect to EIAs on the ONS 15454 backplane using cable connectors. EIAs feature cable-management eyelets for tie wrapping or lacing cables to the cover panel.

## 1.8.5 DS-1 Twisted-Pair Cable Management

Connect twisted pair/DS-1 cables to SMB EIAs on the ONS 15454 backplane using cable connectors and DS-1 electrical interface adapters (baluns).

## 1.8.6 AMP Champ Cable Management

EIAs have cable management eyelets to tiwrap or lace cables to the cover panel. Tie wrap or lace the AMP Champ cables according to local site practice and route the cables. If you configure the ONS 15454 for a 23-inch rack, two additional inches (50.8 mm) of cable management area is available on each side of the shelf assembly.

# 1.9 Alarm Expansion Panel

The optional ONS 15454 alarm expansion panel (AEP) can be used with the Alarm Interface Controller card (AIC-I) card to provide an additional 48 dry alarm contacts for the ONS 15454, 32 of which are inputs and 16 are outputs. The AEP is a printed circuit board assembly that is installed on the backplane. Figure 1-22 shows the AEP board. In Figure 1-22, the left connector is the input connector and the right connector is the output connector.

The AIC-I without an AEP already contains direct alarm contacts. These direct AIC-I alarm contacts are routed through the backplane to wire-wrap pins accessible from the back of the shelf. If you install an AEP, you cannot use the alarm contacts on the wire-wrap pins. For further information about the AIC-I, see the “AIC-I Card” section on page 29.

Figure 1-22 AEP Printed Circuit Board Assembly

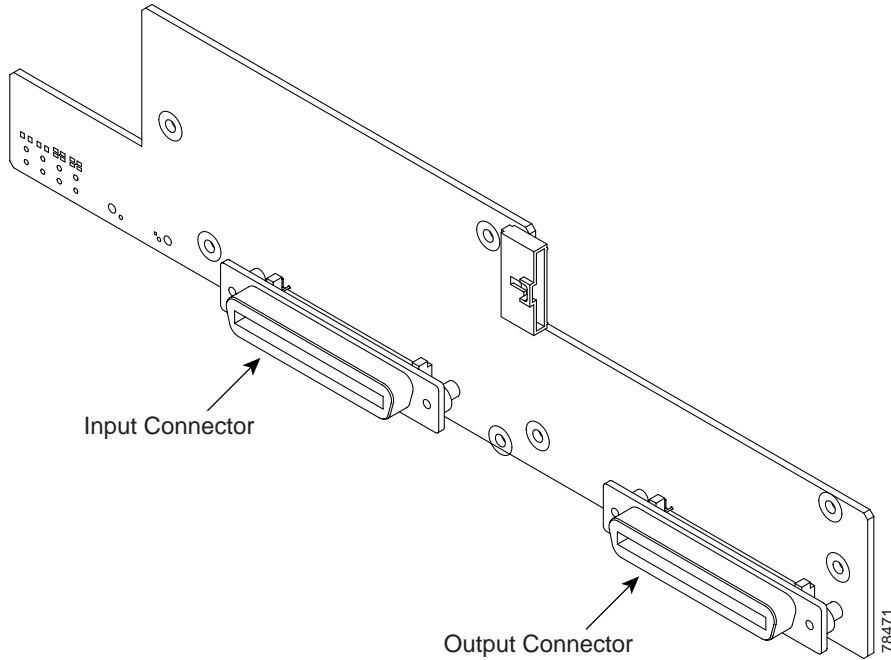
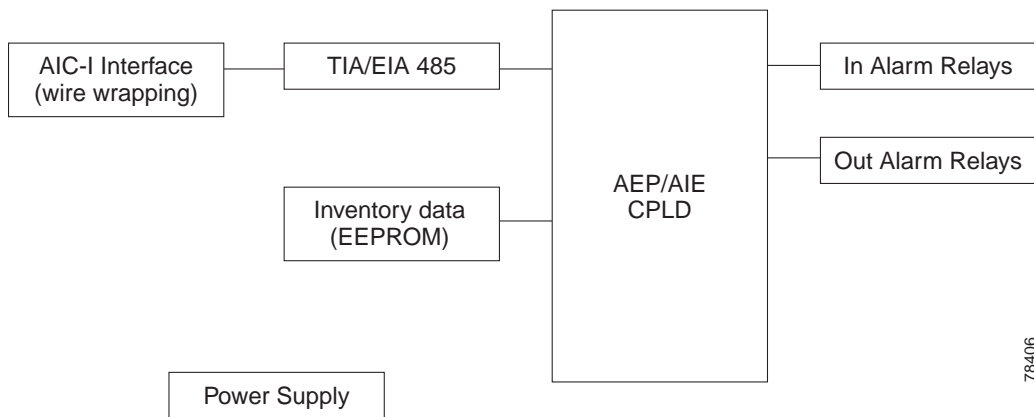

Figure 1-23 shows the AEP block diagram.

Figure 1-23 AEP Block Diagram



Each AEP alarm input port has provisionable label and severity. The alarm inputs have optocoupler isolation. They have one common 32 VDC output and a maximum of 2 mA per input. Each opto metal oxide semiconductor (MOS) alarm output can operate by definable alarm condition, a maximum open circuit voltage of 60 VDC, and a maximum current of 100 mA. See the “External Alarms and Controls” section on page 30 for further information.

## 1.9.1 Wire-Wrap and Pin Connections

Figure 1-24 shows the wire-wrapping connections on the backplane.

Figure 1-24 Wire-Wrapping Connections on the Backplane

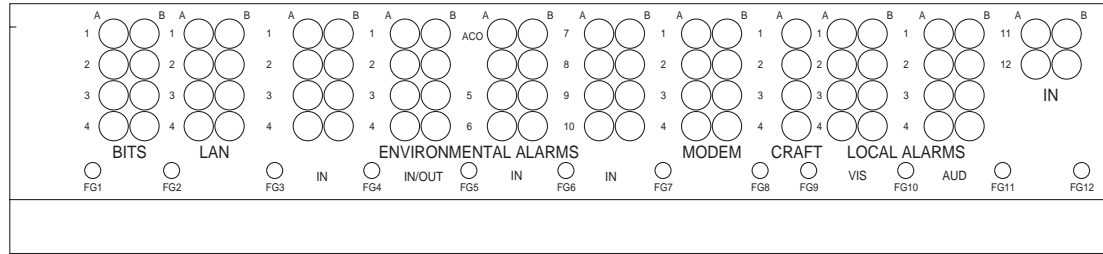

Field	Pin	Function	Field	Pin	Function
BITS	A1	BITS Output 2 negative (-)	ENVIR ALARMS IN/OUT	A1/A13	Normally open output pair number 1
	B1	BITS Output 2 positive (+)		B1/B13	
	A2	BITS Input 2 negative (-)		A2/A14	Normally open output pair number 2
	B2	BITS Input 2 positive (+)		B2/B14	
	A3	BITS Output 1 negative (-)	N/O	A3/A15	Normally open output pair number 3
	B3	BITS Output 1 positive (+)		B3/B15	
	A4	BITS Input 1 negative (-)		A4/A16	Normally open output pair number 4
	B4	BITS Input 1 positive (+)		B4/B16	
LAN	Connecting to a hub, or switch		ACO	A1	Normally open ACO pair
	A1	RJ-45 pin 6 RX-		B1	
	B1	RJ-45 pin 3 RX+	CRAFT	A1	Receive (PC pin #2)
	A2	RJ-45 pin 2 TX-		A2	Transmit (PC pin #3)
	B2	RJ-45 pin 1 TX+		A3	Ground (PC pin #5)
	Connecting to a PC/Workstation or router			A4	DTR (PC pin #4)
	A1	RJ-45 pin 2 RX-	LOCAL ALARMS AUD (Audible)	A1	Alarm output pair number 1: Remote audible alarm.
	B1	RJ-45 pin 1 RX+		B1	
A2	RJ-45 pin 6 TX-	A2		Alarm output pair number 2: Critical audible alarm.	
B2	RJ-45 pin 3 TX+	B2			
ENVIR ALARMS IN	A1	Alarm input pair number 1: Reports closure on connected wires.	N/O	A3	Alarm output pair number 3: Major audible alarm.
	B1			B3	
	A2	Alarm input pair number 2: Reports closure on connected wires.		A4	Alarm output pair number 4: Minor audible alarm.
	B2			B4	
	A3	Alarm input pair number 3: Reports closure on connected wires.	LOCAL ALARMS VIS (Visual)	A1	Alarm output pair number 1: Remote visual alarm.
	B3			B1	
	A4	Alarm input pair number 4: Reports closure on connected wires.		A2	Alarm output pair number 2: Critical visual alarm.
	B4			B2	
	A5	Alarm input pair number 5: Reports closure on connected wires.	N/O	A3	Alarm output pair number 3: Major visual alarm.
	B5			B3	
	A6	Alarm input pair number 6: Reports closure on connected wires.		A4	Alarm output pair number 4: Minor visual alarm.
	B6			B4	
A7	Alarm input pair number 7: Reports closure on connected wires.				
B7					
A8	Alarm input pair number 8: Reports closure on connected wires.				
B8					
A9	Alarm input pair number 9: Reports closure on connected wires.				
B9					
A10	Alarm input pair number 10: Reports closure on connected wires.				
B10					
A11	Alarm input pair number 11: Reports closure on connected wires.				
B11					
A12	Alarm input pair number 12: Reports closure on connected wires.				
B12					

If you are using an AIC-I card, contacts provisioned as OUT are 1-4. Contacts provisioned as IN are 13-16.

83020

Table 1-6 shows the wire-wrap pins and corresponding signals on the AIC-I and AEP.

**Table 1-6 AEP Wire-Wrap Connections**

Wire-Wrap Pin	Signal on AIC-I	Signal on AEP	P1-pins on AEP
TIP_1	GND	AEP_GND	7
TIP_2	AE_+5V	AEP_+5V	8
TIP_3	VBAT-	VBAT-	9
TIP_4	VB+	VB+	10
TIP_6	AE_CLK_P	AE_CLK_P	6
TIP_7	AE_CLK_N	AE_CLK_N	5
TIP_8	AE_DIN_P	AE_DOUT_P	4
TIP_9	AE_DIN_N	AE_DOUT_P	3
TIP_10	AE_DOUT_P	AE_DIN_P	2
TIP_11	AE_DOUT_N	AE_DIN_N	1

Figure 1-25 is a circuit diagram of the alarm inputs (inputs #1 and #32 are shown in the example).

**Figure 1-25 Alarm Input Circuit Diagram**

Table 1-7 lists the connections to the external alarm sources.

**Table 1-7 Alarm Input Pin Association**

AMP Champ Pin Number	Signal name	AMP Champ Pin Number	Signal name
1	ALARM_IN_1-	27	GND
2	GND	28	ALARM_IN_2-
3	ALARM_IN_3-	29	ALARM_IN_4-
4	ALARM_IN_5-	30	GND

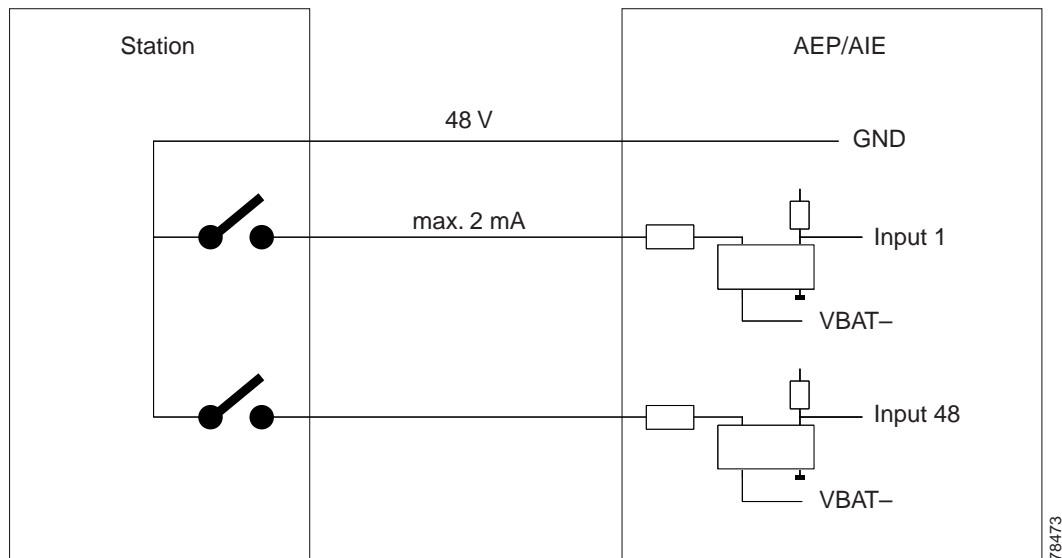
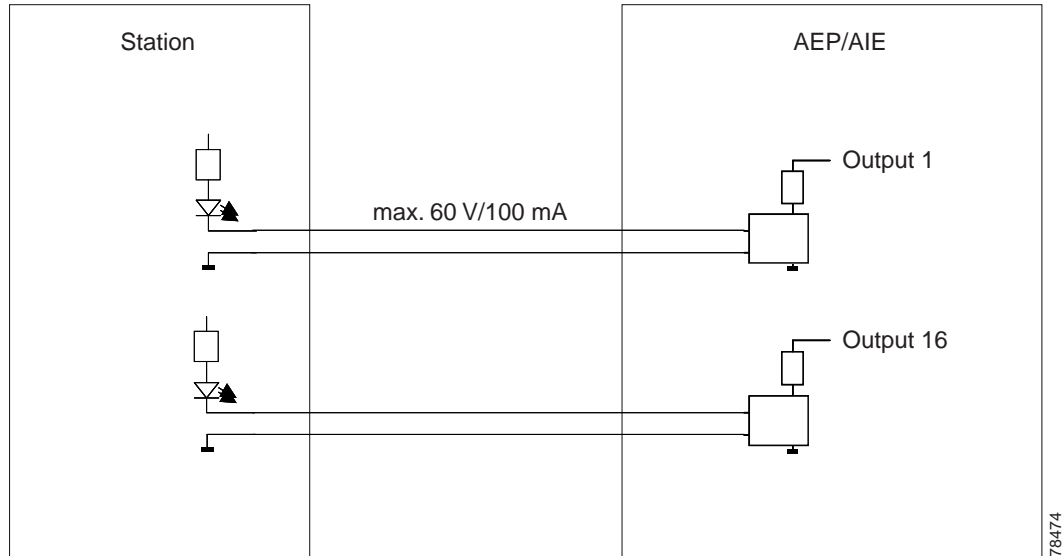

**Table 1-7 Alarm Input Pin Association (continued)**

AMP Champ Pin Number	Signal name	AMP Champ Pin Number	Signal name
5	GND	31	ALARM_IN_6-
6	ALARM_IN_7-	32	ALARM_IN_8-
7	ALARM_IN_9-	33	GND
8	GND	34	ALARM_IN_10-
9	ALARM_IN_11-	35	ALARM_IN_12-
10	ALARM_IN_13-	36	GND
11	GND	37	ALARM_IN_14-
12	ALARM_IN_15-	38	ALARM_IN_16-
13	ALARM_IN_17-	39	GND
14	GND	40	ALARM_IN_18-
15	ALARM_IN_19-	41	ALARM_IN_20-
16	ALARM_IN_21-	42	GND
17	GND	43	ALARM_IN_22-
18	ALARM_IN_23-	44	ALARM_IN_24-
19	ALARM_IN_25-	45	GND
20	GND	46	ALARM_IN_26-
21	ALARM_IN_27-	47	ALARM_IN_28-
22	ALARM_IN_29-	48	GND
23	GND	49	ALARM_IN_30-
24	ALARM_IN_31-	50	N.C.
25	ALARM_IN_+	51	GND1
26	ALARM_IN_0-	52	GND2

Figure 1-26 is a circuit diagram of the alarm outputs (outputs #1 and #16 are shown in the example).

Figure 1-26 Alarm Output Circuit Diagram



Use the pin numbers in Table 1-8 to connect to the external elements being switched by external alarms.

Table 1-8 Pin Association for Alarm Output Pins

AMP Champ Pin Number	Signal name	AMP Champ Pin Number	Signal name
1	N.C.	27	COM_0
2	COM_1	28	N.C.
3	NO_1	29	NO_2
4	N.C.	30	COM_2
5	COM_3	31	N.C.
6	NO_3	32	NO_4
7	N.C.	33	COM_4
8	COM_5	34	N.C.
9	NO_5	35	NO_6
10	N.C.	36	COM_6
11	COM_7	37	N.C.
12	NO_7	38	NO_8
13	N.C.	39	COM_8
14	COM_9	40	N.C.
15	NO_9	41	NO_10
16	N.C.	42	COM_10
17	COM_11	43	N.C.
18	NO_11	44	NO_12
19	N.C.	45	COM_12

Table 1-8 Pin Association for Alarm Output Pins (continued)

AMP Champ Pin Number	Signal name	AMP Champ Pin Number	Signal name
20	COM_13	46	N.C.
21	NO_13	47	NO_14
22	N.C.	48	COM_14
23	COM_15	49	N.C.
24	NO_15	50	N.C.
25	N.C.	51	GND1
26	NO_0	52	GND2

## 1.9.2 AEP Specifications

- Alarm inputs
  - Number of inputs: 32
  - Optocoupler isolated
  - Label customer provisionable
  - Severity customer provisionable
  - Common 32 V output for all alarm-inputs
  - Each input limited to 2 mA
  - Termination: 50-pin AMP champ connector
- Alarm outputs
  - Number of outputs: 16
  - Switched by opto MOS (metal oxide semiconductor)
  - Triggered by definable alarm condition
  - Maximum allowed open circuit voltage: 60 VDC
  - Maximum allowed closed circuit current: 100 mA
  - Termination: 50-pin AMP champ connector
- Environmental
  - Overvoltage protection: as in ITU-T G.703 Annex B
  - Operating temperature: –40 to +65 degrees Celsius
  - Operating humidity: 5 to 95%, non-condensing
  - Power consumption: 3.00 W max., from +5 VDC from AIC-I, 10.2 BTU/Hr. max.
- Dimensions of AEP board
  - Height: 20 mm (0.79 in.)
  - Width: 330 mm (13.0 in.)
  - Depth: 89 mm (3.5 in.)
  - Weight: 0.18 kg (0.4 lb.)

- Compliance
  - Installed ONS 15454 cards comply with these standards:
    - Safety: IEC 60950, EN 60950, UL 60950, CSA C22.2 No. 60950, TS 001, AS/NZS 3260

## 1.10 Fan-Tray Assembly

The fan-tray assembly is located at the bottom of the ONS 15454 fan-tray assembly. The fan tray is a removable drawer that holds fans and fan-control circuitry for the ONS 15454. The front door can be left in place or removed before installing the fan-tray assembly. After you install the fan tray, you should only need to access it if a fan failure occurs or you need to replace or clean the fan-tray air filter.

The front of the fan-tray assembly has an LCD screen that provides slot and port-level information for all ONS 15454 card slots, including the number of Critical, Major, and Minor alarms. The LCD also tells you whether the software load is SONET or SDH and the software version number.

The fan-tray assembly features an air filter at the bottom of the tray that you can install and remove by hand. Remove and visually inspect this filter every 30 days and keep spare filters in stock. Refer to the *Cisco ONS 15454 Troubleshooting Guide* for information about cleaning and maintaining the fan-tray air filter.



### Note

The 15454-SA-ANSI shelf assembly and 15454-FTA3 fan-tray assembly are required with any ONS 15454 that has XC10G cards.



### Caution

Do not operate an ONS 15454 without the mandatory fan-tray air filter.



### Caution

The 15454-FTA3-T fan-tray assembly can only be installed in ONS 15454 Release 3.1 and later shelf assemblies (15454-SA-ANSI, P/N: 800-19857). It includes a pin that does not allow it to be installed in ONS 15454 shelf assemblies released before ONS 15454 Release 3.1 (15454-SA-NEBS3E, 15454-SA-NEBS3, and 15454-SA-R1, P/N: 800-07149). Equipment damage can result from attempting to install the 15454-FTA3 in a non-compatible shelf assembly.



### Note

The 15454-FTA3 is not I-temp. To obtain an I-temp fan tray, install the 15454-FTA3-T fan-tray assembly in an ONS 15454 Release 3.1 shelf assembly (15454-SA-ANSI). However, do not install the ONS 15454 XC10G cross-connect cards with the 15454-FTA2 fan-tray assembly.

### 1.10.1 Fan Speed

If one or more fans fail on the fan-tray assembly, replace the entire assembly. You cannot replace individual fans. The red Fan Fail LED on the front of the fan tray illuminates when one or more fans fail. For fan tray replacement instructions, refer to the *Cisco ONS 15454 Troubleshooting Guide*. The red Fan Fail LED clears after you install a working fan tray.

Fan speed is controlled by TCC+/TCC2 card temperature sensors. The sensors measure the input air temperature at the fan-tray assembly. Fan speed options are low, medium, and high. If the TCC+/TCC2 card fails, the fans automatically shift to high speed. The temperature measured by the TCC+/TCC2 sensors is displayed on the LCD screen.

Table 1-9 lists power requirements for the fan-tray assembly.

**Table 1-9 Fan Tray Assembly Power Requirements**

Fan Tray Assembly	Watts	Amps	BTU/Hr.
FTA2	53	1.21	198
FTA3 -T	86.4	1.8	295

## 1.10.2 Air Filter

The ONS 15454 contains a reusable air filter; Model 15454-FTF2, that is installed either beneath the fan-tray assembly or in the optional external filter brackets. Earlier versions of the ONS 15454 used a disposable air filter that is installed beneath the fan-tray assembly only. However, the reusable air filter is backward compatible.



**Warning**

**Do not reach into a vacant slot or chassis while you install or remove a module or a fan. Exposed circuitry could constitute an energy hazard.**

The reusable filter is made of a gray, open-cell, polyurethane foam that is specially coated to provide fire and fungi resistance. All versions of the ONS 15454 can use the reusable air filter. Spare filters should be kept in stock.

## 1.11 Power and Ground Description

Ground the equipment according to Telcordia standards or local practices.

Cisco recommends the following wiring conventions, but customer conventions prevail:

- Red wire for battery connections (–48 VDC)
- Black wire for battery return connections (0 VDC)

The ONS 15454 has redundant –48 VDC #8 power terminals on the shelf-assembly backplane. The terminals are labeled BAT1, RET1, BAT2, and RET2 and are located on the lower section of the backplane behind a clear plastic cover.

To install redundant power feeds, use four power cables and one ground cable. For a single power feed, only two power cables (#10 AWG, 2.588 mm<sup>2</sup>, copper conductor, 194°F [90°C]) and one ground cable (#6 AWG, 4.115 mm<sup>2</sup>) are required. Use a conductor with low impedance to ensure circuit overcurrent protection. However, the conductor must have the capability to safely conduct any faulty current that might be imposed.



**Note**

If you are installing power on a Release 3.0 ONS 15454 shelf assembly (15454-SA-NEBS3E, 15454-SA-NEBS3, and 15454-SA-R1, P/N: 800-07149), the #12 to #14 AWG (2.053 to 1.628 mm<sup>2</sup>) power cable and #14 AWG (1.628 mm<sup>2</sup>) ground cable are required.

The existing ground post is a #10-32 bolt. The nut provided for a field connection is also a #10 AWG (2.588 mm<sup>2</sup>), with an integral lock washer. The lug must be a dual-hole type and rated to accept the #6 AWG (4.115 mm<sup>2</sup>) cable. Two posts are provided on the Cisco ONS 15454 to accommodate the dual-hole lug. Figure 1-27 shows the location of the ground posts.

**Figure 1-27** Ground Posts on the ONS 15454 Backplane

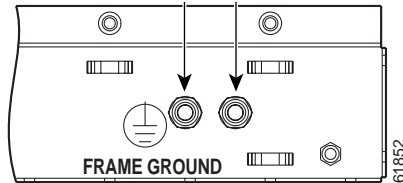

For information about attaching ferrites to power cabling, refer to the “Ferrites” section on page 46.

## 1.12 Alarm, Timing, LAN, and Craft Pin Connections



### Caution

Always use the supplied ESD wristband when working with a powered ONS 15454. Plug the wristband cable into the ESD jack located on the lower-right outside edge of the shelf assembly.

The ONS 15454 has a backplane pin field located at the bottom of the backplane. The backplane pin field provides 0.045 square inch wire-wrap pins for enabling external alarms, timing input and output, and craft interface terminals. This section describes the backplane pin field and the pin assignments for the field. Figure 1-28 shows the wire-wrap pins on the backplane pin field. Beneath each wire-wrap pin is a frame ground pin. Frame ground pins are labeled FG1, FG2, FG3, etc. Install the ground shield of the cables connected to the backplane to the ground pin that corresponds to the pin field used.



### Note

The AIC-I requires a shelf assembly running Software Release 3.4.0 or higher. The backplane of the ANSI shelf contains a wire-wrap field with pin assignment according to the layout in Figure 1-28. The shelf assembly may be an existing shelf that has been upgraded to 3.4 or higher. In this case the backplane pin labeling will appear as indicated in [Figure 1-29 on page 1-40](#). But you must use the pin assignments provided by the AIC-I as shown in Figure 1-28.

Figure 1-28 ONS 15454 Backplane Pinouts (Release 3.4 or Higher)

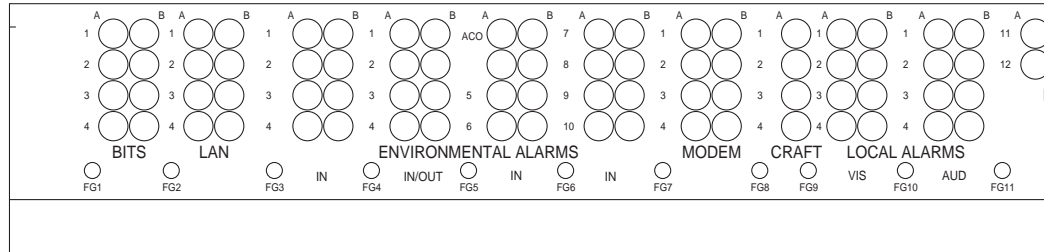

Field	Pin	Function	Field	Pin	Function	
BITS	A1	BITS Output 2 negative (-)	ENVIR ALARMS IN/OUT	A1/A13	Normally open output pair number 1	
	B1	BITS Output 2 positive (+)		B1/B13		
	A2	BITS Input 2 negative (-)		A2/A14	Normally open output pair number 2	
	B2	BITS Input 2 positive (+)		B2/B14		
	A3	BITS Output 1 negative (-)	N/O	A3/A15	Normally open output pair number 3	
	B3	BITS Output 1 positive (+)		B3/B15		
	A4	BITS Input 1 negative (-)		A4/A16	Normally open output pair number 4	
	B4	BITS Input 1 positive (+)		B4/B16		
LAN	Connecting to a hub, or switch		ACO	A1	Normally open ACO pair	
	A1	RJ-45 pin 6 RX-		B1		
	B1	RJ-45 pin 3 RX+	CRAFT	A1	Receive (PC pin #2)	
	A2	RJ-45 pin 2 TX-		A2	Transmit (PC pin #3)	
	B2	RJ-45 pin 1 TX+		A3	Ground (PC pin #5)	
	Connecting to a PC/Workstation or router			A4	DTR (PC pin #4)	
	A1	RJ-45 pin 2 RX-	LOCAL ALARMS AUD (Audible)	A1	Alarm output pair number 1: Remote audible alarm.	
	B1	RJ-45 pin 1 RX+		B1		
A2	RJ-45 pin 6 TX-	A2		Alarm output pair number 2: Critical audible alarm.		
B2	RJ-45 pin 3 TX+	B2				
ENVIR ALARMS IN	A1	Alarm input pair number 1: Reports closure on connected wires.	N/O	A3	Alarm output pair number 3: Major audible alarm.	
	B1	Alarm input pair number 2: Reports closure on connected wires.		B3	Alarm output pair number 4: Minor audible alarm.	
	A2	Alarm input pair number 3: Reports closure on connected wires.		LOCAL ALARMS VIS (Visual)	A1	Alarm output pair number 1: Remote visual alarm.
	B2	Alarm input pair number 4: Reports closure on connected wires.			B1	
	A3	Alarm input pair number 5: Reports closure on connected wires.	A2		Alarm output pair number 2: Critical visual alarm.	
	B3	Alarm input pair number 6: Reports closure on connected wires.	B2			
	A4	Alarm input pair number 7: Reports closure on connected wires.	N/O	A3	Alarm output pair number 3: Major visual alarm.	
	B4	Alarm input pair number 8: Reports closure on connected wires.		B3	Alarm output pair number 4: Minor visual alarm.	
	A5	Alarm input pair number 9: Reports closure on connected wires.		A4		
	B5	Alarm input pair number 10: Reports closure on connected wires.		B4		
	A6	Alarm input pair number 11: Reports closure on connected wires.				
	B6	Alarm input pair number 12: Reports closure on connected wires.				
A7						
B7						
A8						
B8						
A9						
B9						
A10						
B10						
A11						
B11						
A12						
B12						

If you are using AIC-I card, connections 1-4 are provided. Connections 13-16 are not provided.

83020



**Note** The Modem pin field is not active.

Figure 1-29 ONS 15454 Backplane Pinouts (Release 3.3 and Earlier)

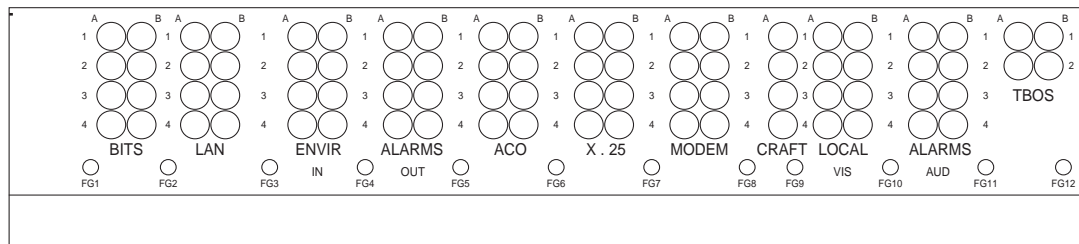

Field	Pin	Function	Field	Pin	Function
BITS	A1	BITS Output 2 negative (-)	ENVIR ALARMS OUT	A1	Normally open output pair number 1
	B1	BITS Output 2 positive (+)		B1	
	A2	BITS Input 2 negative (-)		A2	Normally open output pair number 2
	B2	BITS Input 2 positive (+)		B2	
	A3	BITS Output 1 negative (-)	N/O	A3	Normally open output pair number 3
	B3	BITS Output 1 positive (+)		B3	
	A4	BITS Input 1 negative (-)		A4	Normally open output pair number 4
	B4	BITS Input 1 positive (+)		B4	
LAN	Connecting to a hub, or switch		ACO	A1	Normally open ACO pair
	A1	RJ-45 pin 6 RX-		B1	
	B1	RJ-45 pin 3 RX+	CRAFT	A1	Receive (PC pin #2)
	A2	RJ-45 pin 2 TX-		A2	Transmit (PC pin #3)
	B2	RJ-45 pin 1 TX+		A3	Ground (PC pin #5)
	Connecting to a PC/Workstation or router			A4	DTR (PC pin #4)
	A1	RJ-45 pin 2 RX-	LOCAL ALARMS AUD (Audible)	A1	Alarm output pair number 1: Remote audible alarm.
	B1	RJ-45 pin 1 RX+		B1	
A2	RJ-45 pin 6 TX-	A2		Alarm output pair number 2: Critical audible alarm.	
B2	RJ-45 pin 3 TX+	B2			
ENVIR ALARMS IN	A1	Alarm input pair number 1: Reports closure on connected wires.	N/O	A3	Alarm output pair number 3: Major audible alarm.
	B1	Alarm input pair number 2: Reports closure on connected wires.		B3	
	A2	Alarm input pair number 2: Reports closure on connected wires.		A4	Alarm output pair number 4: Minor audible alarm.
	B2	Alarm input pair number 2: Reports closure on connected wires.		B4	
	A3	Alarm input pair number 3: Reports closure on connected wires.	LOCAL ALARMS VIS (Visual)	A1	Alarm output pair number 1: Remote visual alarm.
	B3	Alarm input pair number 3: Reports closure on connected wires.		B1	
	A4	Alarm input pair number 4: Reports closure on connected wires.		A2	Alarm output pair number 2: Critical visual alarm.
	B4	Alarm input pair number 4: Reports closure on connected wires.		B2	
		N/O	A3	Alarm output pair number 3: Major visual alarm.	
			B3		
			A4	Alarm output pair number 4: Minor visual alarm.	
			B4		

386533



**Note** The X.25, Modem, and TBOS pin fields are not active.

## 1.12.1 Alarm Contact Connections

The alarm pin field supports up to 17 alarm contacts, including four audible alarms, four visual alarms, one alarm cutoff (ACO), and four user-definable alarm input and output contacts.

Audible alarm contacts are in the LOCAL ALARM AUD pin field and visual contacts are in the LOCAL ALARM VIS pin field. Both of these alarms are in the LOCAL ALARMS category. User-definable contacts are in the ENVIR ALARM IN (external alarm) and ENVIR ALARM OUT (external control) pin fields. These alarms are in the ENVIR ALARMS category; you must have the AIC card installed to use the ENVIR ALARMS. Alarm contacts are Normally Open (N/O), meaning that the system closes the



alarm contacts when the corresponding alarm conditions are present. Each alarm contact consists of two wire-wrap pins on the shelf assembly backplane. Visual and audible alarm contacts are classified as critical, major, minor, and remote. [Figure 1-29 on page 1-40](#) shows alarm pin assignments.

Visual and audible alarms are typically wired to trigger an alarm light or bell at a central alarm collection point when the corresponding contacts are closed. You can use the Alarm Cutoff pins to activate a remote ACO for audible alarms. You can also activate the ACO function by pressing the ACO button on the TCC+/TCC2 card faceplate. The ACO function clears all audible alarm indications. After clearing the audible alarm indication, the alarm is still present and viewable in the Alarms tab in CTC.

## 1.12.2 Timing Connections

The ONS 15454 backplane supports two Building Integrated Timing Supply (BITS) clock pin fields. The first four BITS pins, rows 3 and 4, support output and input from the first external timing device. The last four BITS pins, rows 1 and 2, perform the identical functions for the second external timing device. Table 1-10 lists the pin assignments for the BITS timing pin fields.



Note

For timing connection, use 100-ohm shielded BITS clock cable pair #22 or #24 AWG (0.51 mm<sup>2</sup> or 0.64 mm<sup>2</sup>), twisted-pair T1-type.

**Table 1-10 BITS External Timing Pin Assignments**

External Device	Contact	Tip and Ring	Function
First external device	A3 (BITS 1 Out)	Primary ring (-)	Output to external device
	B3 (BITS 1 Out)	Primary tip (+)	Output to external device
	A4 (BITS 1 In)	Secondary ring (-)	Input from external device
	B4 (BITS 1 In)	Secondary tip (+)	Input from external device
Second external device	A1 (BITS 2 Out)	Primary ring (-)	Output to external device
	B1 (BITS 2 Out)	Primary tip (+)	Output to external device
	A2 (BITS 2 In)	Secondary ring (-)	Input from external device
	B2 (BITS 2 In)	Secondary tip (+)	Input from external device



Note

Refer to Telcordia SR-NWT-002224 for rules about provisioning timing references.

## 1.12.3 LAN Connections

Use the LAN pins on the ONS 15454 backplane to connect the ONS 15454 to a workstation or Ethernet LAN, or to a LAN modem for remote access to the node. You can also use the LAN port on the TCC+/TCC2 faceplate to connect a workstation or to connect the ONS 15454 to the network. Table 1-11 on page 1-42 shows the LAN pin assignments.

Before you can connect an ONS 15454 to other ONS 15454s or to a LAN, you must change the default IP address that is shipped with each ONS 15454 (192.1.0.2).

**Table 1-11 LAN Pin Assignments**

Pin Field	Backplane Pins	RJ-45 Pins
LAN 1 Connecting to data circuit-terminating equipment (DCE <sup>1</sup> ) (a hub or switch)	B2	1
	A2	2
	B1	3
	A1	6
LAN 1 Connecting to data terminal equipment (DTE) (a PC/workstation or router)	B1	1
	A1	2
	B2	3
	A2	6

1. The Cisco ONS 15454 is DCE.

## 1.12.4 TL1 Craft Interface Installation

You can use the craft pins on the ONS 15454 backplane or the EIA/TIA-232 port on the TCC+/TCC2 faceplate to create a VT100 emulation window to serve as a TL1 craft interface to the ONS 15454. Use a straight-through cable to connect to the EIA/TIA-232 port. Table 1-12 shows the pin assignments for the CRAFT pin field.



**Note**

You cannot use the craft backplane pins and the EIA/TIA-232 port on the TCC+/TCC2 card simultaneously.

**Table 1-12 Craft Interface Pin Assignments**

Pin Field	Contact	Function
Craft	A1	Receive
	A2	Transmit
	A3	Ground
	A4	DTR

## 1.13 Cards and Slots

ONS 15454 cards have electrical plugs at the back that plug into electrical connectors on the shelf-assembly backplane. When the ejectors are fully closed, the card plugs into the assembly backplane. [Figure 1-30 on page 1-43](#) shows card installation.

Figure 1-30 Installing Cards in the ONS 15454

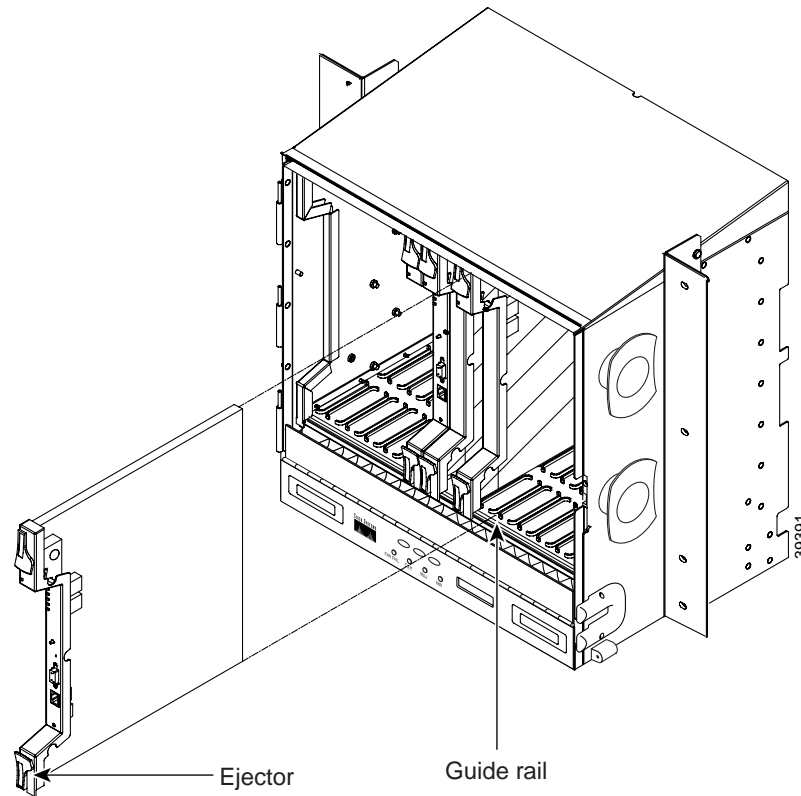

### 1.13.1 Card Slot Requirements

The ONS 15454 shelf assembly has 17 card slots numbered sequentially from left to right. Slots 1 to 4 and 14 to 17 are multispeed slots. They can host any ONS 15454 card, except the OC48 IR 1310, OC48 LR 1550, OC48 ELR 1550, and OC192 LR 1550 cards. Slots 5, 6, 12, and 13 are high-speed slots. They can host all ONS 15454 cards, except the OC12/STM4-4 and OC3-8 cards. You can install the OC48 IR/STM16 SH AS 1310 and the OC48 LR/STM16 LH AS 1550 cards in any multispeed or high-speed card slot.

Slots 7 and 11 are dedicated to TCC+/TCC2 cards. Slots 8 and 10 are dedicated to cross-connect (XC, XCVT, XC10G) cards. Slot 9 is reserved for the optional Alarm Interface Controller (AIC or AIC-I) card. Slots 3 and 15 can also host DS1N-14 and DS3N-12 cards that are used in 1:N protection.



#### Caution

Do not operate the ONS 15454 with a single TCC+ or TCC2 card or a single XC/XCVT/XC10G card installed. Always operate the shelf assembly with one working and one protect card of the same type.

Shelf assembly slots have symbols indicating the type of cards that you can install in them. Each ONS 15454 card has a corresponding symbol. The symbol on the card must match the symbol on the slot.

Table 1-13 shows the slot and card symbol definitions.

**Note**

Protection schemes and EIA types can affect slot compatibility. Refer to the “Card Compatibility” section on page 2 for more detailed compatibility information.

**Table 1-13 Slot and Card Symbols**

Symbol Color/Shape	Definition
Orange/Circle	Slots 1 to 6 and 12 to 17. Only install ONS 15454 cards with a circle symbol on the faceplate.
Blue/Triangle	Slots 5, 6, 12, and 13. Only install ONS 15454 cards with circle or a triangle symbol on the faceplate.
Purple/Square	TCC+/TCC2 slot, Slots 7 and 11. Only install ONS 15454 cards with a square symbol on the faceplate.
Green/Cross	Cross-connect (XC/XCVT/XC10G) slot, i.e. Slots 8 and 10. Only install ONS 15454 cards with a cross symbol on the faceplate.
Red/P	Protection slot in 1:N protection schemes.
Red/Diamond	AIC slot, that is Slot 9. Only install ONS 15454 cards with a diamond symbol on the faceplate.
Gold/Star	Slots 1 to 4 and 14 to 17. Only install ONS 15454 cards with a star symbol on the faceplate.

Table 1-14 lists the number of ports, line rates, connector options, and connector locations for ONS 15454 optical and electrical cards.

**Table 1-14 Card Ports, Line Rates, and Connectors**

Card	Ports	Line Rate per Port	Connector Types	Connector Location
DS1-14	14	1.544 Mbps	SMB w/wire wrap adapter, AMP Champ Connector	Backplane
DS1N-14	14	1.544 Mbps	SMB w/wire wrap <sup>1</sup> adapter, AMP Champ Connector	—
DS3-12	12	44.736 Mbps	SMB or BNC <sup>1</sup>	Backplane
DS3N-12	12	44.736 Mbps	SMB or BNC <sup>1</sup>	—
DS3-12E	12	44.736 Mbps	SMB or BNC <sup>1</sup>	Backplane
DS3N-12E	12	44.736 Mbps	SMB or BNC <sup>1</sup>	—
DS3XM-6	6	44.736 Mbps	SMB or BNC <sup>1</sup>	Backplane
EC1-12	12	51.84 Mbps	SMB or BNC <sup>1</sup>	Backplane
E100T-12	12	100 Mbps	RJ-45	Faceplate
E1000-2	2	1 Gbps	SC (GBIC)	Faceplate

Table 1-14 Card Ports, Line Rates, and Connectors (continued)

Card	Ports	Line Rate per Port	Connector Types	Connector Location
E100T-G	12	100 Mbps	RJ-45	Faceplate
E1000-2-G	2	1 Gbps	SC (GBIC)	Faceplate
G1000-4	4	1 Gbps	SC (GBIC)	Faceplate
G1K-4	4	1 Gbps	SC (GBIC)	Faceplate
ML100T-12	12	100 Mbps	RJ-45	Faceplate
ML1000-2	2	1 Gbps	LC (SFP)	Faceplate
OC-3 IR	4	155.52 Mbps (STS-3)	SC	Faceplate
OC3 IR/STM4 SH 1310-8	8	155.52 Mbps (STS-3)	LC	Faceplate
OC-12/STM4-4 (IR/LR)	4	622.08 Mbps (STS-12)	SC	Faceplate
OC-12 (IR/LR)	1	622.08 Mbps (STS-12)	SC	Faceplate
OC-48 (IR/LR/ELR)	1	2488.32 Mbps (STS-48)	SC	Faceplate
OC-48 AS (IR/LR)	1	2488.32 Mbps (STS-48)	SC	Faceplate
OC-48 ELR (100GHz, 200GHz)	1	2488.32 Mbps (STS-48)	SC	Faceplate
OC192 SR/STM64 IO 1310	1	9.95 Gbps (STS-192)	SC	Faceplate
OC192 IR/STM64 SH 1550	1	9.95 Gbps (STS-192)	SC	Faceplate
OC192 LR/STM64 LH 1550	1	9.95 Gbps (STS-192)	SC	Faceplate
OC192 LR/STM64 LH ITU 15xx.xx	1	9.95 Gbps (STS-192)	SC	Faceplate
TXP_MR_10G	1 (client)	9.95 Gbps (STS-192)	SC	Faceplate
	1 (trunk)	9.95 Gbps (STS-192)	SC	
MXP_2.5G_10G	4 (client)	2488.32 Mbps (STS-48)	LC SFP	Faceplate
	1 (trunk)	9.95 Gbps (STS-192)	SC	

1. When used as a protect card, the card does not have a physical external connection. The protect card connects to the working card(s) through the backplane and becomes active when the working card fails. The protect card then uses the physical connection of the failed card.

## 1.13.2 Card Replacement

To replace an ONS 15454 card with another card of the same type, you do not need to make any changes to the database; remove the old card and replace it with a new card. To replace a card with a card of a different type, physically remove the card and replace it with the new card, then delete the original card from CTC. For specifics, refer to the *Cisco ONS 15454 Procedure Guide*.



### Caution

Removing any active card from the ONS 15454 can result in traffic interruption. Use caution when replacing cards and verify that only inactive or standby cards are being replaced. If the active card needs to be replaced, switch it to standby prior to removing the card from the node. For traffic switching procedures, refer to the *Cisco ONS 15454 Procedure Guide*.



### Note

An improper removal (IMPROPRMVL) alarm is raised whenever a card pull (reseat) is performed, unless the card is deleted in CTC first. The alarm will clear after the card replacement is complete.



### Note

In a path protection, pulling the active XC/XCVT/XC10G without a lockout will cause path protection circuits to switch.



### Warning

**Do not reach into a vacant slot or chassis while you install or remove a module or a fan. Exposed circuitry could constitute an energy hazard.**

## 1.14 Ferrites

Place third-party ferrites on certain cables to dampen electromagnetic interference (EMI) from the ONS 15454. Ferrites must be added to meet the requirements of Telcordia GR-1089-CORE. Refer to the ferrite manufacturer documentation for proper use and installation of the ferrites. Ferrite placements on the ONS 15454 can include power cables, AMP Champ connectors, baluns, BNC/SMB connectors, and the wire-wrap pin field.

## 1.15 Software and Hardware Compatibility

Table 1-15 shows ONS 15454 software and hardware compatibility for systems configured with XC/XCVT cards for Releases 2.0, 2.1, 2.2.0, 3.0, 3.1, 3.2, 3.3, 3.4, 4.0, and 4.1.



### Note

The XC10G card is not supported before Release 3.1. Release 4.5 is not supported by x-connect cards.

Table 1-15 ONS 15454 Software and Hardware Compatibility—XC/XCVT Configurations

Hardware	2.00.0x (2.0)	2.10.0x (2.1)	2.20.0x (2.2.0)	3.00.0x (3.0)	3.10.0x (3.1)	3.20.0x (3.2)	3.30.0x (3.3)	3.40.0x (3.4)	4.0.0x (4.0) 4.1.0x (4.1)
XC <sup>1</sup>	Fully Compatible	Fully Compatible	Fully Compatible	Fully Compatible	Fully Compatible	Fully Compatible	Fully Compatible	Fully Compatible	Fully Compatible
XCVT	Fully Compatible	Fully Compatible	Fully Compatible	Fully Compatible	Fully Compatible	Fully Compatible	Fully Compatible	Fully Compatible	Fully Compatible
TCC	Required	Required	Fully Compatible	Not Supported	Not Supported	Not Supported	Not Supported	Not Supported	Not Supported
TCC+	Not Supported	Not Supported	Fully Compatible	Required	Required	Required	Required	Required	Fully Compatible
TCC2	Not Supported	Not Supported	Not Supported	Not Supported	Not Supported	Not Supported	Not Supported	Not Supported	Fully Compatible
AIC	Fully Compatible	Fully Compatible	Fully Compatible	Fully Compatible	Fully Compatible	Fully Compatible	Fully Compatible	Fully Compatible	Fully Compatible
AIC-I	Not Supported	Not Supported	Not Supported	Not Supported	Not Supported	Not Supported	Not Supported	Fully Compatible	Fully Compatible
DS1-14	Fully Compatible	Fully Compatible	Fully Compatible	Fully Compatible	Fully Compatible	Fully Compatible	Fully Compatible	Fully Compatible	Fully Compatible
DS1N-14	Fully Compatible	Fully Compatible	Fully Compatible	Fully Compatible	Fully Compatible	Fully Compatible	Fully Compatible	Fully Compatible	Fully Compatible
DS3-12	Fully Compatible	Fully Compatible	Fully Compatible	Fully Compatible	Fully Compatible	Fully Compatible	Fully Compatible	Fully Compatible	Fully Compatible
DS3N-12	Fully Compatible	Fully Compatible	Fully Compatible	Fully Compatible	Fully Compatible	Fully Compatible	Fully Compatible	Fully Compatible	Fully Compatible
DS3-12E	Supported <sup>2</sup>			Fully Compatible	Fully Compatible	Fully Compatible	Fully Compatible	Fully Compatible	Fully Compatible
DS3N-12E				Fully Compatible	Fully Compatible	Fully Compatible	Fully Compatible	Fully Compatible	Fully Compatible
DS3XM-6	Fully Compatible	Fully Compatible	Fully Compatible	Fully Compatible	Fully Compatible	Fully Compatible	Fully Compatible	Fully Compatible	Fully Compatible
EC1-12	Fully Compatible	Fully Compatible	Fully Compatible	Fully Compatible	Fully Compatible	Fully Compatible	Fully Compatible	Fully Compatible	Fully Compatible
E100T-12	Fully Compatible	Fully Compatible	Fully Compatible	Fully Compatible	Fully Compatible	Fully Compatible	Fully Compatible	Fully Compatible	Fully Compatible
E1000-2	Not Supported	Not Supported	Fully Compatible	Fully Compatible	Fully Compatible	Fully Compatible	Fully Compatible	Fully Compatible	Fully Compatible
E100T-12-G	Fully Compatible	Fully Compatible	Fully Compatible	Fully Compatible	Fully Compatible	Fully Compatible	Fully Compatible	Fully Compatible	Fully Compatible
E1000-2-G	Not Supported	Not Supported	Fully Compatible	Fully Compatible	Fully Compatible	Fully Compatible	Fully Compatible	Fully Compatible	Fully Compatible
G1000-4	Not Supported	Not Supported	Not Supported	Not Supported	Not Supported	Not Supported	Not Supported	Not Supported	Not Supported
G1K-4	Not Supported	Not Supported	Not Supported	Not Supported	Not Supported	Not Supported	Not Supported	Not Supported	Supported in Slots 5, 6, 12, 13

Table 1-15 ONS 15454 Software and Hardware Compatibility—XC/XCVT Configurations (continued)

Hardware	2.00.0x (2.0)	2.10.0x (2.1)	2.20.0x (2.2.0)	3.00.0x (3.0)	3.10.0x (3.1)	3.20.0x (3.2)	3.30.0x (3.3)	3.40.0x (3.4)	4.0.0x (4.0) 4.1.0x (4.1)
ML100T-12	Not Supported	Not Supported	Not Supported	Not Supported	Not Supported	Not Supported	Not Supported	Not Supported	Supported in Slots 5, 6, 12, 13
ML1000-2	Not Supported	Not Supported	Not Supported	Not Supported	Not Supported	Not Supported	Not Supported	Not Supported	Supported in Slots 5, 6, 12, 13
OC3 IR 4/STM1 SH 1310	Fully Compatible	Fully Compatible	Fully Compatible	Fully Compatible	Fully Compatible	Fully Compatible	Fully Compatible	Fully Compatible	Fully Compatible
OC3IR/STM 1SH 1310-8	Not Supported	Not Supported	Not Supported	Not Supported	Not Supported	Not Supported	Not Supported	Not Supported	Fully Compatible
OC12 IR 1310	Fully Compatible	Fully Compatible	Fully Compatible	Fully Compatible	Fully Compatible	Fully Compatible	Fully Compatible	Fully Compatible	Fully Compatible
OC12 IR/4 1310	Not Supported	Not Supported	Not Supported	Not Supported	Not Supported	Not Supported	Not Supported	Not Supported	Fully Compatible
OC12 LR 1310	Fully Compatible	Fully Compatible	Fully Compatible	Fully Compatible	Fully Compatible	Fully Compatible	Fully Compatible	Fully Compatible	Fully Compatible
OC12 LR 1550	Fully Compatible	Fully Compatible	Fully Compatible	Fully Compatible	Fully Compatible	Fully Compatible	Fully Compatible	Fully Compatible	Fully Compatible
OC48 IR 1310	Fully Compatible	Fully Compatible	Fully Compatible	Fully Compatible	Fully Compatible	Fully Compatible	Fully Compatible	Fully Compatible	Fully Compatible
OC48 LR 1550	Fully Compatible	Fully Compatible	Fully Compatible	Fully Compatible	Fully Compatible	Fully Compatible	Fully Compatible	Fully Compatible	Fully Compatible
OC48 ELR DWDM	Fully Compatible	Fully Compatible	Fully Compatible	Fully Compatible	Fully Compatible	Fully Compatible	Fully Compatible	Fully Compatible	Fully Compatible
OC48 IR/STM16 SH AS 1310	Supported <sup>3</sup>				Fully Compatible	Fully Compatible	Fully Compatible	Fully Compatible	Fully Compatible
OC48 LR/STM16 LH AS 1550					Fully Compatible	Fully Compatible	Fully Compatible	Fully Compatible	Fully Compatible
OC192 SR/STM64 IO 1310	Not Supported	Not Supported	Not Supported	Not Supported	Not Supported	Not Supported	Not Supported	Not Supported	Not Supported
OC192 IR/STM64 SH 1550	Not Supported	Not Supported	Not Supported	Not Supported	Not Supported	Not Supported	Not Supported	Not Supported	Not Supported
OC192 LH/STM64 LH 1550	Not Supported	Not Supported	Not Supported	Not Supported	Not Supported	Not Supported	Not Supported	Not Supported	Not Supported
OC192 LR/STM64 LH ITU 15xx.xx	Not Supported	Not Supported	Not Supported	Not Supported	Not Supported	Not Supported	Not Supported	Not Supported	Not Supported
TXP_MR_2. 5G	Not Supported	Not Supported	Not Supported	Not Supported	Not Supported	Not Supported	Not Supported	Not Supported	Fully Supported



**Table 1-15 ONS 15454 Software and Hardware Compatibility—XC/XCVT Configurations (continued)**

Hardware	2.00.0x (2.0)	2.10.0x (2.1)	2.20.0x (2.2.0)	3.00.0x (3.0)	3.10.0x (3.1)	3.20.0x (3.2)	3.30.0x (3.3)	3.40.0x (3.4)	4.0.0x (4.0) 4.1.0x (4.1)
TXPP_MR_2.5G	Not Supported	Not Supported	Not Supported	Not Supported	Not Supported	Not Supported	Not Supported	Not Supported	Fully Supported
TXP_MR_10G	Not Supported	Not Supported	Not Supported	Not Supported	Not Supported	Not Supported	Not Supported	Not Supported	Fully Supported
MXP_2.5G_10G	Not Supported	Not Supported	Not Supported	Not Supported	Not Supported	Not Supported	Not Supported	Not Supported	Fully Supported

1. VT 1.5 provisioning is not supported for the XC.
2. In Software R2.0 – 2.2, extended features are not supported for the DS3-12E and DS3N-12E cards.
3. You must use the XC10G card (Table 1-16), the TCC+/TCC2 card, and Software R3.1 or higher to enable the any slot function on the OC48 IR/STM16 SH AS 1310 and OC48 LR/STM16 LH AS 1550 cards.

Table 1-16 shows the ONS 15454 software and hardware compatibility for nodes configured with XC10G cards for Releases 3.1, 3.2, 3.3, 3.4, and 4.0. The 15454-SA-ANSI shelf assembly is required to operate the XC10G card.

**Table 1-16 ONS 15454 Software and Hardware Compatibility—XC10G Configurations**

Hardware	3.10.0x (3.1)	3.20.0x (3.2)	3.30.0x (3.3)	3.40.0x (3.4)	4.0.0x (4.0)	4.1.0x (4.1)	4.5.0x (4.5)
TCC+	TCC+ Required	TCC+ Required	TCC+ Required	TCC+ Required	TCC+ or TCC2 Required	TCC+ or TCC2 Required	Not Supported
TCC2	Not Supported	Not Supported	Not Supported	Not Supported	TCC+ or TCC2 Required	TCC+ or TCC2 Required	Required
XC10G	Fully Compatible	Fully Compatible	Fully Compatible	Fully Compatible	Fully Compatible	Fully Compatible	Not Supported
AIC	Fully Compatible	Fully Compatible	Fully Compatible	Fully Compatible	Fully Compatible	Fully Compatible	Not Supported
AIC-I	Not Supported	Not Supported	Not Supported	Fully Compatible	Fully Compatible	Fully Compatible	Not Supported
DS1-14	Fully Compatible	Fully Compatible	Fully Compatible	Fully Compatible	Fully Compatible	Fully Compatible	Not Supported
DS1N-14	Fully Compatible	Fully Compatible	Fully Compatible	Fully Compatible	Fully Compatible	Fully Compatible	Not Supported
DS3-12	Fully Compatible	Fully Compatible	Fully Compatible	Fully Compatible	Fully Compatible	Fully Compatible	Not Supported
DS3N-12	Fully Compatible	Fully Compatible	Fully Compatible	Fully Compatible	Fully Compatible	Fully Compatible	Not Supported
DS3-12E	Fully Compatible	Fully Compatible	Fully Compatible	Fully Compatible	Fully Compatible	Fully Compatible	Not Supported
DS3N-12E	Fully Compatible	Fully Compatible	Fully Compatible	Fully Compatible	Fully Compatible	Fully Compatible	Not Supported
DS3XM-6	Fully Compatible	Fully Compatible	Fully Compatible	Fully Compatible	Fully Compatible	Fully Compatible	Not Supported

Table 1-16 ONS 15454 Software and Hardware Compatibility—XC10G Configurations (continued)

Hardware	3.10.0x (3.1)	3.20.0x (3.2)	3.30.0x (3.3)	3.40.0x (3.4)	4.0.0x (4.0)	4.1.0x (4.1)	4.5.0x (4.5)
EC1-12	Fully Compatible	Fully Compatible	Fully Compatible	Fully Compatible	Fully Compatible	Fully Compatible	Not Supported
E100T	Not Supported	Not Supported	Not Supported	Not Supported	Not Supported	Not Supported	Not Supported
E1000	Not Supported	Not Supported	Not Supported	Not Supported	Not Supported	Not Supported	Not Supported
E100T-12-G	Fully Compatible	Fully Compatible	Fully Compatible	Fully Compatible	Fully Compatible	Fully Compatible	Not Supported
E1000-2-G	Fully Compatible	Fully Compatible	Fully Compatible	Fully Compatible	Fully Compatible	Fully Compatible	Not Supported
G1000-4	Fully Compatible	Fully Compatible	Fully Compatible	Fully Compatible	Fully Compatible	Fully Compatible	Not Supported
G1K-4	Fully Compatible	Fully Compatible	Fully Compatible	Fully Compatible	Fully Compatible	Fully Compatible	Not Supported
ML100T-12	Not Supported	Not Supported	Not Supported	Not Supported	Fully Supported	Fully Supported	Not Supported
ML1000-2	Not Supported	Not Supported	Not Supported	Not Supported	Fully Compatible	Fully Compatible	Not Supported
OC3 IR 4/STM1 SH 1310	Fully Compatible	Fully Compatible	Fully Compatible	Fully Compatible	Fully Compatible	Fully Compatible	Not Supported
OC3IR/STM1S H 1310-8	Not Supported	Not Supported	Not Supported	Not Supported	Fully Compatible, Slots 1-4, 14-17	Fully Compatible, Slots 1-4, 14-17	Not Supported
OC12/STM4-4	Not Supported	Not Supported	Fully Compatible	Fully Compatible	Fully Compatible	Fully Compatible	Not Supported
OC12 IR 1310	Fully Compatible	Fully Compatible	Fully Compatible	Fully Compatible	Fully Compatible	Fully Compatible	Not Supported
OC12 LR 1310	Fully Compatible	Fully Compatible	Fully Compatible	Fully Compatible	Fully Compatible	Fully Compatible	Not Supported
OC12 LR 1550	Fully Compatible	Fully Compatible	Fully Compatible	Fully Compatible	Fully Compatible	Fully Compatible	Not Supported
OC48 IR 1310	Fully Compatible	Fully Compatible	Fully Compatible	Fully Compatible	Fully Compatible	Fully Compatible	Not Supported
OC48 LR 1550	Fully Compatible	Fully Compatible	Fully Compatible	Fully Compatible	Fully Compatible	Fully Compatible	Not Supported
OC48 ELR DWDM	Fully Compatible	Fully Compatible	Fully Compatible	Fully Compatible	Fully Compatible	Fully Compatible	Not Supported
OC48 IR/STM16 SH AS 1310	Fully Compatible	Fully Compatible	Fully Compatible	Fully Compatible	Fully Compatible	Fully Compatible	Not Supported

Table 1-16 ONS 15454 Software and Hardware Compatibility—XC10G Configurations (continued)

Hardware	3.10.0x (3.1)	3.20.0x (3.2)	3.30.0x (3.3)	3.40.0x (3.4)	4.0.0x (4.0)	4.1.0x (4.1)	4.5.0x (4.5)
OC48 LR/STM16 LH AS 1550	Fully Compatible	Fully Compatible	Fully Compatible	Fully Compatible	Fully Compatible	Fully Compatible	Not Supported
OC192 SR/STM64 IO 1310	Not Supported	Not Supported	Not Supported	Not Supported	Fully Compatible	Fully Compatible	Not Supported
OC192 IR/STM64 SH 1550	Not Supported	Not Supported	Not Supported	Not Supported	Fully Compatible	Fully Compatible	Not Supported
OC192 LR/STM64 LH 1550	Fully Compatible	Fully Compatible	Fully Compatible	Fully Compatible	Fully Compatible	Fully Compatible	Not Supported
OC192 LR/STM64 LH ITU 15xx.xx	Not Supported	Not Supported	Not Supported	Not Supported	Fully Compatible	Fully Compatible	Not Supported
TXP_MR_10G	Not Supported	Not Supported	Not Supported	Not Supported	Fully Compatible	Not Supported	Not Supported
MXP_2.5G_10G	Not Supported	Not Supported	Not Supported	Not Supported	Fully Compatible	Not Supported	Not Supported
TXP_MR_10G	Not Supported	Not Supported	Not Supported	Not Supported	Fully Compatible	Not Supported	Not Supported
MXP_2.5G_10G	Not Supported	Not Supported	Not Supported	Not Supported	Fully Compatible	Not Supported	Not Supported
MR-L1-xx.x	Not Supported	Not Supported	Not Supported	Not Supported	Not Supported	Not Supported	Fully Compatible
MRP-L1-xx.xx	Not Supported	Not Supported	Not Supported	Not Supported	Not Supported	Not Supported	Fully Compatible
OSC	Not Supported	Not Supported	Not Supported	Not Supported	Not Supported	Not Supported	Fully Compatible
OSC-CSM	Not Supported	Not Supported	Not Supported	Not Supported	Not Supported	Not Supported	Fully Compatible
OPT-PRE	Not Supported	Not Supported	Not Supported	Not Supported	Not Supported	Not Supported	Fully Compatible
OPT-BST	Not Supported	Not Supported	Not Supported	Not Supported	Not Supported	Not Supported	Fully Compatible
32MUX-O	Not Supported	Not Supported	Not Supported	Not Supported	Not Supported	Not Supported	Fully Compatible
32DMX-O	Not Supported	Not Supported	Not Supported	Not Supported	Not Supported	Not Supported	Fully Compatible
4MD-xx.x	Not Supported	Not Supported	Not Supported	Not Supported	Not Supported	Not Supported	Fully Compatible
AD-1C-xx.x	Not Supported	Not Supported	Not Supported	Not Supported	Not Supported	Not Supported	Fully Compatible

**Table 1-16 ONS 15454 Software and Hardware Compatibility—XC10G Configurations (continued)**

Hardware	3.10.0x (3.1)	3.20.0x (3.2)	3.30.0x (3.3)	3.40.0x (3.4)	4.0.0x (4.0)	4.1.0x (4.1)	4.5.0x (4.5)
AD-2C-xx.x	Not Supported	Not Supported	Not Supported	Not Supported	Not Supported	Not Supported	Fully Compatible
AD-4C-xx.x	Not Supported	Not Supported	Not Supported	Not Supported	Not Supported	Not Supported	Fully Compatible
AD-1B-xx.x	Not Supported	Not Supported	Not Supported	Not Supported	Not Supported	Not Supported	Fully Compatible
AD-4B-xx.x	Not Supported	Not Supported	Not Supported	Not Supported	Not Supported	Not Supported	Fully Compatible

If an upgrade is required for compatibility, contact the Technical Assistance Center (TAC). For contact information, go to <http://www.cisco.com/tac>.