



Configuring Resilient Ethernet Protocol

This chapter describes Resilient Ethernet Protocol (REP), REP configuration guidelines, VLAN load balancing, REP timers, and REP over EVC. This chapter also describes procedures to configure REP.

- [Understanding Resilient Ethernet Protocol, page 1](#)
- [Understanding VLAN Load Balancing, page 20](#)
- [Understanding REP Configurable Timers, page 25](#)
- [Understanding REP with EVC, page 29](#)
- [REP with Other Features, page 38](#)

Understanding Resilient Ethernet Protocol

The Resilient Ethernet Protocol (REP) is a protocol that provides an alternative to Spanning Tree Protocol (STP) to support L2 resiliency, and fast switchover with Ethernet networks. REP provides a way to control network loops, handle link failures, and improve convergence time.

REP performs the following tasks:

- Controls a group of ports connected in a segment.
- Ensures that the segment does not create any bridging loops.
- Handles single link failure within the segment.
- Improves convergence time.
- Supports VLAN load balancing.

REP Configuration Procedures

The following procedures can be performed using Cisco IOS commands to configure REP:

- [DLP-J29 Configure REP Administrative VLAN Using Cisco IOS Commands, on page 10](#)
- [DLP-J31 Enable REP on a Port Using Cisco IOS Commands, on page 13](#)
- [DLP-J32 Configure STCN on the Primary Edge Port Using Cisco IOS Commands, on page 14](#)

- [DLP-J38 Configure VLAN Load Balancing on the Primary Edge Port Using Cisco IOS Commands, on page 21](#)
- [DLP-J33 Configure Preemption Delay on the Primary Edge Port Using Cisco IOS Commands, on page 15](#)
- [DLP-J39 Configure the Preemption for VLAN Load Balancing Using Cisco IOS Commands, on page 23](#)
- [DLP-J42 Configure REP Link Status Layer Retries Using Cisco IOS Commands, on page 26](#)
- [DLP-J43 Configure the REP Link Status Layer Ageout Timer Using Cisco IOS Commands, on page 28](#)
- [DLP-J44 Configure REP over EVC Using a Cross-Connect Using Cisco IOS Commands, on page 31](#)
- [DLP-J45 Configure REP over EVC Using the Bridge Domain Using Cisco IOS Commands, on page 34](#)
- [Verify REP with EVC Configuration Using Cisco IOS Commands, on page 36](#)

The following procedures can be performed using CTC to configure REP:

- [DLP-J30 Configure REP Administrative VLAN Using CTC, on page 11](#)
- [DLP-J34 Create a Segment Using CTC, on page 17](#)
- [DLP-J35 Edit a Segment Using CTC, on page 19](#)
- [DLP-J40 Activate VLAN Load Balancing Using CTC, on page 24](#)
- [DLP-J41 Deactivate VLAN Load Balancing Using CTC, on page 25](#)

Understanding REP Segments

A REP segment is a chain of ports connected to each other and configured with a segment ID. Each segment consists of standard (non-edge) segment ports and two user-configured edge ports. The two edge ports terminate the segments.

A router cannot have more than two ports that belong to the same segment, and each segment port can have only one external neighbor. A segment can go through a shared medium, but on any link only two ports can belong to the same segment. REP is supported only on Layer 2 interfaces.

[Figure 1: REP Open Segments, on page 3](#) shows an example of a segment consisting of six ports spread across four switches. Ports E1 and E2 are configured as edge ports. When all ports are operational (as in the

segment on the left), a single port is blocked, shown by the diagonal line. When there is a failure in the network, the blocked port returns to the forwarding state to minimize network disruption.

Figure 1: REP Open Segments

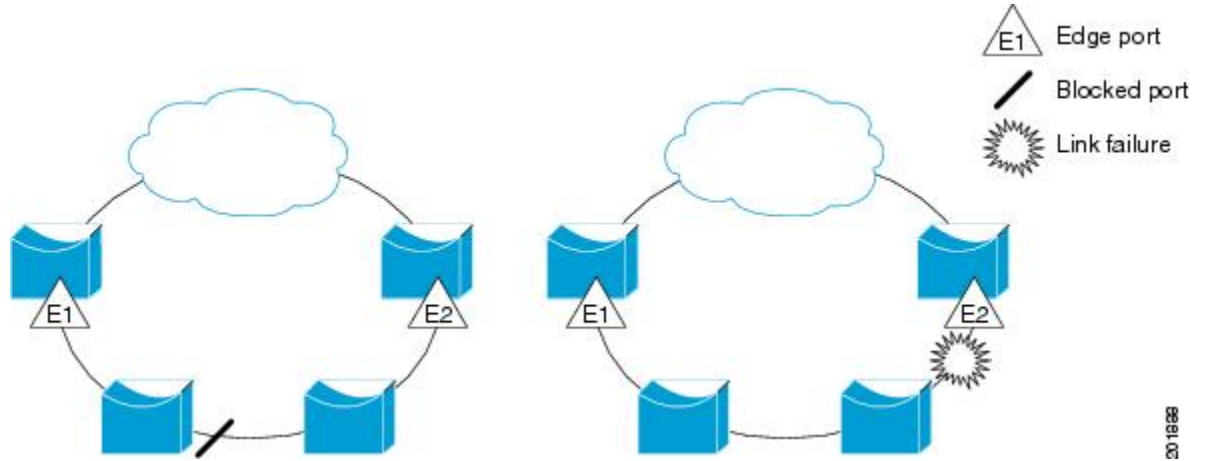

The segment shown in [Figure 1: REP Open Segments, on page 3](#) is an open segment; there is no connectivity between the two edge ports. The REP segment cannot cause a bridging loop and it is safe to connect the segment edges to any network. The traffic from a REP ring node toward the network cloud is sent to either of the edge nodes, depending on the location of the alternate port. If a failure is detected anywhere in the ring, the alternate port changes to an open port forwarding all traffic. This may cause the traffic being redirected to the other edge node depending on the fault location. It ensures that data flow is maintained between a particular REP node and the network cloud. If a failure occurs on any segment or any port on a REP segment, REP unblocks all the ports to ensure that connectivity is available through the other edge.

The segment shown in [Figure 2: REP Ring Segment, on page 3](#), with both edge ports located on the same router, is a ring segment. In this configuration, there is connectivity between the edge ports through the segment. With this configuration, you can create a redundant connection between any two routers in the segment.

Figure 2: REP Ring Segment

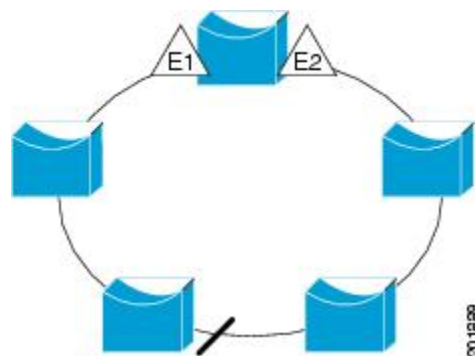

Characteristics of REP Segments

REP segments have the following characteristics:

- If all the ports in the segment are operational, one port (referred to as the alternate port) blocks traffic for each VLAN. If VLAN load balancing is configured, two ports in the segment control the blocked state of VLANs.
- If one or more ports in a segment is not operational, causing a link failure, all ports forward traffic on all VLANs to ensure connectivity. The Failed ports are blocked for all traffic, while all the other ports in the ring stay in open state.
- In case of a link failure, the alternate ports are immediately unblocked. When the failed link comes up, a logically blocked port per VLAN is selected with minimal disruption to the network. When VLAN load balancing preemption timer is set, VLAN load balancing is automatically applied after the last failure has recovered. There are 2 alternate ports when VLAN load balancing takes effect.

Understanding Link Adjacency

REP does not use an end-to-end polling mechanism between edge ports to verify link integrity. It implements local link failure detection. When enabled on an interface, the REP Link Status Layer (LSL) detects its REP-aware neighbor and establishes connectivity within the segment. All VLANs are blocked on an interface until it detects the neighbor. After the neighbor is identified, REP determines which neighbor port should become the alternate port and which ports should forward traffic.

Each port in a segment has a unique port ID. When a segment port starts, the LSL layer sends packets that include the segment ID and the port ID. The port is declared as operational after it performs a three-way handshake with a neighbor in the same segment.

A segment port does not become operational under the following conditions:

- No neighbor port has the same segment ID.
- More than one neighbor port has the same segment ID.
- The neighbor port does not acknowledge the local port as a peer.

Each port creates an adjacency with its immediate neighbor. When the neighbor adjacencies are created, the ports negotiate to determine one blocked port for the segment, the alternate port. All other ports become unblocked.

Understanding Fast Convergence

A failure in a REP segment is noticed and propagated across the ring by LSL and HFL messages. LSL messages are sent hop by hop on the control plane, with each node receiving, processing, and forwarding LSL messages. This process is time-consuming.

HFL messages are flooded in the data plane across the ring on a preconfigured administrative VLAN, using a fixed multicast address. This results in each node receiving failure notifications instantaneously. Using HFL, traffic reconvergence is achieved fast, leading to insignificant loss of traffic on segment failure.

HFL messages are handled as data packets on the nodes in a ring which do not have the REP configured. The administrative VLAN is common to all the REP segments that are configured on a node.

Convergence time varies depending on the type and number of nodes that are present on the ring.

REP Edge No-Neighbor

You can configure the non-REP switch facing ports as edge no-neighbor ports. These ports inherit the properties of edge ports, and overcome the limitation of not being able to converge quickly during a failure.

You can configure the non-REP facing ports (E1 and E2) as edge no-neighbor ports as shown in [Figure 3: Edge No-Neighbor Ports](#), on page 5. These ports inherit all the properties of edge ports. You can configure these no-neighbor ports as any other edge port and also enable the ports to send REP topology change notifications to the aggregation switch.

Figure 3: Edge No-Neighbor Ports

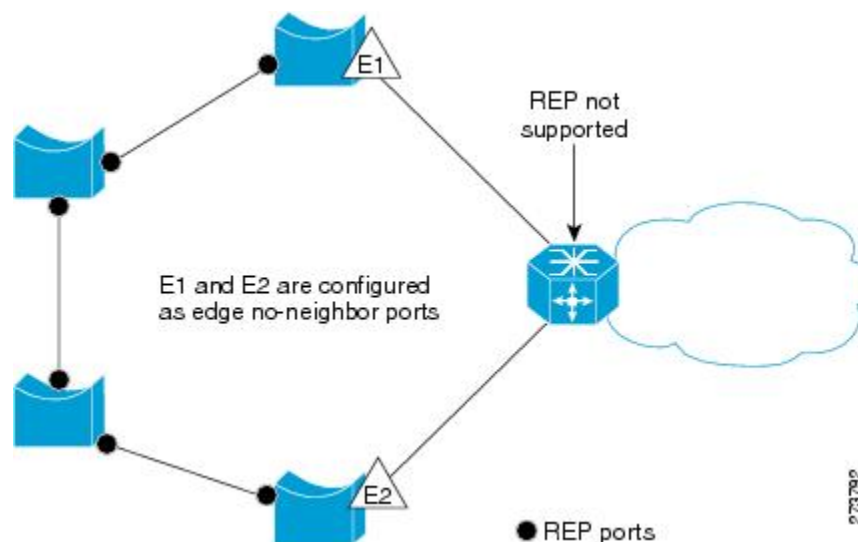

Understanding REP Ports

Ports in REP segments take one of three roles or states—Failed, Open, or Alternate.

- A port configured as a regular segment port starts as a failed port.
- When the neighbor adjacencies are determined, the port transitions to the alternate port state, blocking all the VLANs on the interface. Blocked port negotiations occur and when the segment settles, one blocked port remains in the alternate role and all the other ports become open ports.
- When a failure occurs in a link, all the ports move to the failed state. When the alternate port receives the failure notification, it changes to the open state, forwarding all VLANs.

If you convert an edge port into a regular segment port, VLAN load balancing is not implemented unless it has been configured. For VLAN load balancing, you must configure two edge ports in the segment.

REP Actions on Packets

REP performs specific actions depending on the type of packets.

The following actions are taken by REP on packets that originate from an alternate port.

Packet type	Block/Allow (TX)	Action (TX)	Block/Allow (RX)	Action (RX)
REP LSL packet	Allow	—	Allow	Punt to CPU
REP HFL packet	Allow	—	Allow	Punt to CPU; no forward
Tagged control packet	Block if VLAN is blocked on the port	—	Block if VLAN is blocked on the port	As per the configured protocol and EVC, if VLAN is not blocked.
Untagged control packet	Block	—	Block	—
Tagged data packet	Block if VLAN is blocked on the port	—	Block if VLAN is blocked on the port	As per EVC, if VLAN is not blocked.
Untagged data packet	Block	—	Block	—

REP blocks untagged packets on a port only when VLAN load balancing is not in effect. When VLAN load balancing takes effect, all the untagged packets flow across an alternate port.

The following actions are taken by REP on packets that originate from an open port (a port that is not blocked by REP).

Packet type	Block/Allow (TX)	Action (TX)	Block/Allow (RX)	Action (RX)
REP LSL packet	Allow	—	Allow	Punt to CPU
REP HFL packet	Allow only packets that originate from the node	—	Allow	Punt to CPU and forward as per EVC
Tagged control packet	Allow	—	Allow	As per the configured protocol and EVC
Untagged control packet	Allow	—	Allow	As per the configured protocol and EVC
Tagged data packet	Allow	—	Allow	As per EVC
Untagged data packet	Allow	—	Allow	As per EVC

Default REP Configuration

REP is disabled on all the interfaces by default. When enabled, the interface is a regular segment port unless it is configured as an edge port.

When REP is enabled, the sending of segment topology change notifications (STCNs) is disabled, all VLANs are blocked, and the administrative VLAN is VLAN 1. When REP administrative VLAN or STCN configuration is changed, the changed configuration applies to ports.

When VLAN load balancing is enabled, the default is manual preemption with the delay timer disabled. If VLAN load balancing is not configured, the default action after manual preemption is to block all the VLANs at the elected alternate port.

**Note**

REP cannot be enabled on the ports where link configuration is already present.

REP Configuration Guidelines

Follow these guidelines when configuring REP:

- REP ports must be a Layer 2 IEEE 802.1Q port or 802.1AD port.
- You must configure all trunk ports in the segment with the same set of allowed VLANs, or misconfiguration occurs.
- Be careful when configuring REP through a Telnet connection. Because REP blocks all VLANs until another REP interface sends a message to unblock it or you might lose connectivity to the router if you enable REP in a Telnet session that accesses the router through the same interface.
- If REP is enabled on two ports on a router, both ports must be either regular segment ports or edge ports. REP ports follow these rules:
 - If only one port on a router is configured in a segment, the port should be an edge port.
 - If two ports on a router belong to the same segment, both ports must be regular segment ports.
 - If two ports on a router belong to the same segment and one is configured as an edge port and one as a regular segment port (a misconfiguration), the edge port is treated as a regular segment port.
- REP interfaces come up in a blocked state and do not forward traffic till they change to open ports through exchange of LSL HELLO messages with neighbors. You need to be aware of this to avoid sudden connection losses.
- REP configuration parameters for a port must not be changed without shutting down the port. However, the VLAN range for VLAN load balancing on primary edge port can be changed without this restriction.
- When configuring VLAN load balancing, the port selected for load balancing and the primary edge port must be on different nodes. Otherwise, it may cause HFL packets to flood, when VLAN Load Balancing is activated.
- When configuring STCN, ensure that STCN propagates across the REP segments in one direction. When STCN is sent from a segment, the STCN packet must not reach the original segment. Otherwise, it may cause an infinite loop of STCN packets flowing across the segments.

- REP is not supported on service instances configured with encapsulation, untagged, or default type.

REP Configuration Sequence

You must perform the following tasks in sequence to configure REP:

- Configure the REP administrative VLAN. The range of the REP admin VLAN is from 2 to 4094. The default VLAN 1 is always configured for HFL packets. However, EVC configuration must be explicitly done for VLAN 1, or any other VLAN that is selected to be an administrative VLAN. See [DLP-J29 Configure REP Administrative VLAN Using Cisco IOS Commands](#), on page 10.
- Enable REP on ports and assign a segment ID to it. REP is disabled on all ports by default. The range of the segment ID is from 1 to 1024. See [DLP-J31 Enable REP on a Port Using Cisco IOS Commands](#), on page 13.
- Configure two edge ports in the segment; one port as the primary edge port and the other as the secondary edge port. See [DLP-J31 Enable REP on a Port Using Cisco IOS Commands](#), on page 13.

If you configure two ports in a segment as the primary edge port, for example, ports on different switches, REP selects one of the ports to serve as the primary edge port based on port priority. The Primary option is enabled only on edge ports.

- Configure the primary edge port to send STCNs and VLAN load balancing to another port or to other segments. STCNs and VLAN load balancing configurations are enabled only for edge ports. See [DLP-J32 Configure STCN on the Primary Edge Port Using Cisco IOS Commands](#), on page 14 and [DLP-J38 Configure VLAN Load Balancing on the Primary Edge Port Using Cisco IOS Commands](#), on page 21.

Understanding REP in a Ring

Resilient Ethernet Protocol (REP) is supported on the front port Ethernet Flow Points (EFP) in a ring for loop prevention and network reconvergence. It is supported on the control channel of the 10G interlink ring ports. It is used for CPT 50 topology discovery and in keeping the control channel loop-free. By default, REP is enabled on all the ports in a ring.

This table lists the default values of the REP parameters on the east port of a ring.

Parameter	Default Value
Port Role	Primary (Edge)
STCN	Disable
VLAN Load Balancing	(For a closed-ended ring) Enable (For an open-ended ring) Disable
Neighbor No	-1
VLB Preempt Delay (in seconds)	(Only for a closed-ended ring) 15
Retries (in seconds)	5
Ageout Timer (in milliseconds)	5000

This table lists the default values of the REP parameters on the west port of a ring.

**Note**

The details for west port is applicable only to a closed-ended ring.

Parameter	Default Value
Port Role	Preferred (Edge)
STCN	Disable
VLAN Load Balancing	Enable
Neighbor No	-1
VLB Preempt Delay (in seconds)	15
Retries (in seconds)	5
Ageout Timer (in milliseconds)	5000

Understanding REP Administrative VLAN

To avoid the delay introduced by relaying messages related to link-failure or VLAN-blocking notification during VLAN load balancing, REP floods packets at the HFL to a regular multicast address. HFL packets are used for fast transmission of failure notification across a REP ring by flooding a BPA on a VLAN. These messages are flooded to the whole network, not just the REP segment. You can control flooding of these messages by configuring an administrative VLAN for the whole domain.

Follow these guidelines when configuring the REP administrative VLAN:

- If you do not configure an administrative VLAN, the default VLAN is VLAN 1. The default VLAN 1 is always configured.
- There can be only one administrative VLAN on a router and on a segment.

The administrative VLAN is configured at the system level. Whenever the administrative VLAN is changed, the corresponding EFP must also be manually configured to match the outer encapsulation for tagged control packets. The EFP must be associated with a bridge domain used exclusively for administrative VLAN EFPs. The VLAN marked as administrative VLAN must not be used for any other service or data traffic.

NTP-J12 Configure REP Administrative VLAN

Purpose	This procedure configures REP Administrative VLAN.
Tools/Equipment	None
Prerequisite Procedures	None
Required/As Needed	As needed

Onsite/Remote	Onsite or remote
Security Level	Provisioning or higher

Procedure

Perform any of the following procedures as needed:

- [DLP-J29 Configure REP Administrative VLAN Using Cisco IOS Commands](#), on page 10
- [DLP-J30 Configure REP Administrative VLAN Using CTC](#), on page 11

Stop. You have completed this procedure.

DLP-J29 Configure REP Administrative VLAN Using Cisco IOS Commands

Purpose	This procedure configures REP administrative VLAN using Cisco IOS commands.
Tools/Equipment	None
Prerequisite Procedures	None
Required/As Needed	As needed
Onsite/Remote	Onsite or remote
Security Level	Provisioning or higher

Procedure

	Command or Action	Purpose
Step 1	enable Example: Router> enable	Enables privileged EXEC mode. <ul style="list-style-type: none"> • Enter your password if prompted.
Step 2	configure terminal Example: Router# configure terminal	Enters global configuration mode.
Step 3	rep admin vlan <i>vlan-id</i> Example: Router(config)# rep admin vlan 100	Configures an REP administrative VLAN. The range of the REP administrative VLAN is from 2 to 4094. The default value is VLAN 1.

	Command or Action	Purpose
Step 4	end Example: Router(config)# end	Returns to privileged EXEC mode.
Step 5	show interface [interface-id] rep detail Example: Router# show interface TenGigabitEthernet4/1 rep detail	Displays the REP configuration and status for a specified interface.
Step 6	Return to your originating procedure (NTP).	—

Example: Configure REP Administrative VLAN

The following example shows how to configure the administrative VLAN as VLAN 100.

```
Router> enable
Router# configure terminal
Router(config)# rep admin vlan 100
Router(config)# end
```

DLP-J30 Configure REP Administrative VLAN Using CTC

Purpose	This procedure configures REP administrative VLAN using CTC.
Tools/Equipment	None
Prerequisite Procedures	None
Required/As Needed	As needed
Onsite/Remote	Onsite or remote
Security Level	Provisioning or higher

Procedure

-
- Step 1** Complete the [NTP-J22 Log into CTC](#) procedure at a node where you want to configure the REP administrative VLAN.
- Step 2** From the View menu, choose **Go to Home View**.
- Step 3** Right-click the fabric or line card and choose **Open Packet Transport System View**. The Packet Transport System View dialog box appears.
- Step 4** Click the **Provisioning** tab.
- Step 5** From the left pane, click **REP**.
- Step 6** Click the **Admin VLAN Configuration** tab.
- Step 7** From the VLAN drop-down list, choose a VLAN. The range of the REP administrative VLAN is from 2 to 4094. The default value is VLAN 1.
- Step 8** Click **Apply**.
- Step 9** Return to your originating procedure (NTP).
-

NTP-J13 Configure REP

Purpose	This procedure configures REP.
Tools/Equipment	None
Prerequisite Procedures	None
Required/As Needed	As needed
Onsite/Remote	Onsite or remote
Security Level	Provisioning or higher

Procedure

Perform any of the following procedures as needed:

- [DLP-J31 Enable REP on a Port Using Cisco IOS Commands](#), on page 13
- [DLP-J32 Configure STCN on the Primary Edge Port Using Cisco IOS Commands](#), on page 14
- [DLP-J33 Configure Preemption Delay on the Primary Edge Port Using Cisco IOS Commands](#), on page 15
- [DLP-J34 Create a Segment Using CTC](#), on page 17
- [DLP-J35 Edit a Segment Using CTC](#), on page 19

Stop. You have completed this procedure.

DLP-J31 Enable REP on a Port Using Cisco IOS Commands

Purpose	This procedure enables REP on a port using Cisco IOS commands.
Tools/Equipment	None
Prerequisite Procedures	DLP-J29 Configure REP Administrative VLAN Using Cisco IOS Commands , on page 10
Required/As Needed	As needed
Onsite/Remote	Onsite or remote
Security Level	Provisioning or higher

Procedure

	Command or Action	Purpose
Step 1	enable Example: Router> enable	Enables privileged EXEC mode. <ul style="list-style-type: none"> • Enter your password if prompted.
Step 2	configure terminal Example: Router# configure terminal	Enters global configuration mode.
Step 3	interface <i>interface-id</i> Example: Router(config)# interface TenGigabitEthernet4/1	Specifies the interface and enters the interface configuration mode.
Step 4	rep segment <i>segment-id</i> [edge [no-neighbor] [primary]] [preferred] Example: Router(config-if)# rep segment 1 edge preferred	Enables REP on the interface, and identifies a segment number. The segment ID range value is from 1 to 1024. <p>Note You must configure a primary and secondary edge port on each segment. The following optional keywords are available.</p> <ul style="list-style-type: none"> • Enter edge to configure the port as an edge port. Each segment has only two edge ports. • Enter no-neighbor to specify that the edge port must not have a neighbor port.

	Command or Action	Purpose
		<ul style="list-style-type: none"> Enter primary to configure the port as the primary edge port where you can configure VLAN load balancing. Enter preferred to indicate that the port is the preferred alternate port or the preferred port for VLAN load balancing. <p>Note Configuring a port as preferred does not guarantee that it becomes the alternate port; it merely gives it a slight edge among equal contenders. The alternate port is usually a previously failed port.</p>
Step 5	end Example: Router(config-if)# end	Returns to privileged EXEC mode.
Step 6	show interface [interface-id] rep detail Example: Router(config)# show interface TenGigabitEthernet4/1 rep detail	Displays the REP interface configuration.
Step 7	Return to your originating procedure (NTP).	—

DLP-J32 Configure STCN on the Primary Edge Port Using Cisco IOS Commands

Purpose	This procedure configures the primary edge port to send STCNs to other segments or to an interface using Cisco IOS commands.
Tools/Equipment	None
Prerequisite Procedures	DLP-J31 Enable REP on a Port Using Cisco IOS Commands , on page 13
Required/As Needed	As needed
Onsite/Remote	Onsite or remote
Security Level	Provisioning or higher

**Note**

Perform this procedure only on edge ports and not on regular segment ports.

Procedure

	Command or Action	Purpose
Step 1	enable Example: Router> enable	Enables privileged EXEC mode. • Enter your password if prompted.
Step 2	configure terminal Example: Router# configure terminal	Enters global configuration mode.
Step 3	interface <i>interface-id</i> Example: Router(config)# interface TenGigabitEthernet4/1	Specifies the interface and enters interface configuration mode.
Step 4	rep stcn { interface <i>interface-id</i> segment <i>segment-id-list</i> } Example: Router(config-if)# rep stcn segment 2-5	Configures the edge port to send STCNs to one or more segments or to an interface.
Step 5	end Example: Router(config-if)# end	Returns to privileged EXEC mode.
Step 6	Return to your originating procedure (NTP).	—

DLP-J33 Configure Preemption Delay on the Primary Edge Port Using Cisco IOS Commands

Purpose	This procedure configures preemption time delay on the primary edge port using Cisco IOS commands.
Tools/Equipment	None
Prerequisite Procedures	DLP-J31 Enable REP on a Port Using Cisco IOS Commands , on page 13
Required/As Needed	As needed

Onsite/Remote	Onsite or remote
Security Level	Provisioning or higher

Procedure

	Command or Action	Purpose
Step 1	enable Example: Router> enable	Enables privileged EXEC mode. • Enter your password if prompted.
Step 2	configure terminal Example: Router# configure terminal	Enters global configuration mode.
Step 3	interface <i>interface-id</i> Example: Router(config)# interface TenGigabitEthernet4/1	Specifies the interface and enters interface configuration mode.
Step 4	rep preempt delay <i>seconds</i> Example: Router(config-if)# rep preempt delay 60	Configures a preempt time delay. Use this command if you want VLAN load balancing to automatically trigger after a link failure and recovery. The time delay range is from 15 to 300 seconds. The default action is manual preemption with no time delay.
Step 5	end Example: Router(config-if)# end	Returns to privileged EXEC mode.
Step 6	Return to your originating procedure (NTP).	—

Example: Configure a REP Interface Using Cisco IOS Commands

The following example shows how to configure an interface as the primary edge port for segment 1, to send STCNs to segments 2 through 5, and to configure the alternate port as the port with port ID 0009001818D68700 to block all VLANs after a preempt delay of 60 seconds after a segment port failure and recovery.

```
Router# configure terminal
Router(config)# interface TenGigabitEthernet4/1
Router(config-if)# rep segment 1 edge primary
Router(config-if)# rep stcn segment 2-5
```



```
Router(config-if)# rep block port 0009001818D68700 vlan all
Router(config-if)# rep preempt delay 60
Router(config-if)# end
```

The following example shows how to configure the VLAN blocking configuration shown in [Figure 4: Example of VLAN Blocking, on page 17](#). The alternate port is the neighbor with neighbor offset number 4. After manual preemption, VLANs 100 to 200 are blocked at this port and all other VLANs are blocked at the primary edge port E1 (TenGigabitEthernet4/1).

```
Router# configure terminal
Router(config)# interface TenGigabitEthernet4/1
Router(config-if)# rep segment 1 edge primary
Router(config-if)# rep block port 4 vlan 100-200
Router(config-if)# end
```

Figure 4: Example of VLAN Blocking

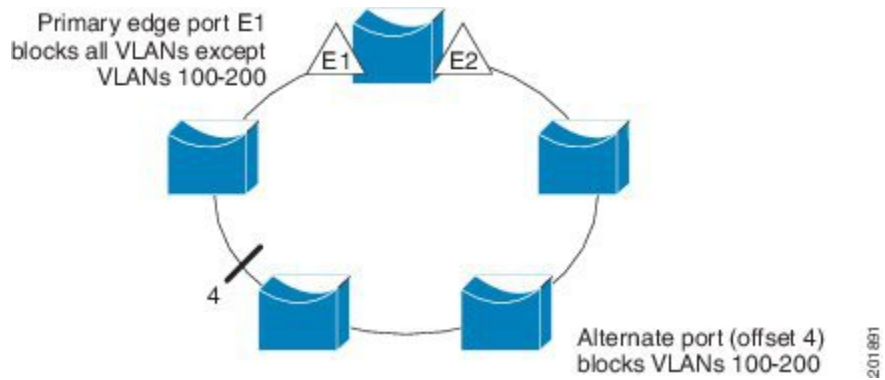

DLP-J34 Create a Segment Using CTC

Purpose	This procedure creates a REP segment using CTC.
Tools/Equipment	None
Prerequisite Procedures	DLP-J30 Configure REP Administrative VLAN Using CTC, on page 11
Required/As Needed	As needed
Onsite/Remote	Onsite or remote
Security Level	Provisioning or higher

- You must configure two edge ports in the segment. A segment has only one primary edge port. If you configure two ports in a segment as the primary edge port, for example, ports on different switches, REP selects one of the ports to serve as the primary edge port based on port priority.
- If REP is enabled on two ports on a switch, both the ports must be either regular ports or edge ports. However, if the No-neighbor port is configured, one port can be an edge port and another port can be a regular port.

- You can also optionally configure where to send STCNs and VLAN load balancing (VLB). STCNs can be enabled on any edge port. VLB can be enabled only on primary edge ports.



Note You can create up to 32 REP segments.

Procedure

- Step 1** Complete the [NTP-J22 Log into CTC](#) procedure at a node where you want to create a segment.
- Step 2** From the View menu, choose **Go to Home View**.
- Step 3** Right-click the fabric or line card and choose **Open Packet Transport System View**. The Packet Transport System View dialog box appears.
- Step 4** Click the **Provisioning** tab.
- Step 5** From the left pane, click **REP**.
- Step 6** Click the **Segment** tab.
- Step 7** Click **Create**. The Create Segment dialog box appears.
- Step 8** Enter the segment ID in the Segment No field. The range of the segment ID is 1 to 1024.
- Step 9** From the Slot drop-down list, choose a slot.
- Step 10** From the Port drop-down list, choose a REP port that must belong to this segment.
- Note** A REP port can belong to only one segment.
- Step 11** From the Port Role area, choose whether you want to configure the port as an edge port or a regular port. The options are:
- Edge—The port is configured as an edge port.
 - Check the **Primary** check box to configure the edge port as a primary edge port. Otherwise, uncheck the **Primary** check box to configure the edge port as a secondary edge port.
 - Check the **Preferred** check box to configure the edge port as a preferred alternate port.
 - Check the **NoNeighbor** check box if the edge port must not have a neighbor port. REP does not check for neighbor adjacency.
 - None—The port is configured as a regular port. If you choose this option, STCN and VLAN Load Balancing configurations are disabled.
 - Check the **Preferred** check box to configure the edge port as a preferred alternate port.
- Step 12** From the STCN area, configure the destination of STCN messages:
- Check the **Enable** check box to enable sending STCN messages.
 - From the Port drop-down list, choose the STCN port to send STCN messages or enter the segment ID in the Segment No field to send STCN messages. The STCN port and REP port must be unique.
- Step 13** From the VLAN Load Balancing area, configure VLAN load balancing on the primary edge port:
- Check the **Enable** check box to enable VLAN load balancing.
 - Enter a single VLAN or range of VLANs in the VLAN field.
 - Choose **Preferred**, **Port Id**, or **Neighbor Id**. Complete one of the following steps:

- Choose **Preferred** to identify the preferred alternate port for VLAN load balancing.
- Choose **Port Id** and enter the REP port ID in the Rep PortId field.
- Choose **Neighbor Id** and enter the neighbor port id in the Neighbor No field.

- Step 14** From the VLB Preempt Delay area, configure preemption delay on the primary edge port:
- Check the **Enable** check box to enable preemption delay.
 - Enter the trigger delay for automatic VLB activation in the Trigger Delay field. The range is from 15 to 300 seconds.
- Step 15** Enter the number of LSL retries before the REP link is disabled in the Retries field. The range is from 3 to 10 seconds.
- Step 16** Enter the LSL age out timer value in the Time field. The range is from 120 to 10000 milliseconds.
- Step 17** Click **Next**.
- Step 18** Enter the details of the second port to add it to the segment.
- Step 19** Click **Finish** to create a REP segment.
The new segment is added to the Selected Segment table.
- Step 20** Return to your originating procedure (NTP).
-

DLP-J35 Edit a Segment Using CTC

Purpose	This procedure edits a segment using CTC.
Tools/Equipment	None
Prerequisite Procedures	DLP-J34 Create a Segment Using CTC, on page 17
Required/As Needed	As needed
Onsite/Remote	Onsite or remote
Security Level	Provisioning or higher

Procedure

-
- Step 1** Complete the [NTP-J22 Log into CTC](#) procedure at a node where you want to edit a segment.
 - Step 2** From the View menu, choose **Go to Home View**.
 - Step 3** Right-click the fabric or line card and choose **Open Packet Transport System View**. The Packet Transport System View dialog box appears.
 - Step 4** Click the **Provisioning** tab.
 - Step 5** From the left pane, click **REP**.
 - Step 6** Click the **Segment** tab. The list of segments appear in the Selected Segment table.
 - Step 7** Choose a segment from the list of segments.
 - Step 8** Click **Edit**. The Edit Segment dialog box appears.
 - Step 9** Modify the values as required and click **Finish**.
 - Step 10** Return to your originating procedure (NTP).
-

Understanding VLAN Load Balancing

REP supports VLAN load balancing, controlled by the primary edge port but occurring at any port in the segment.

You must configure two edge ports in the segment for VLAN load balancing. One edge port in the REP segment acts as the primary edge port; the other edge port as the secondary edge port.

The primary edge port always participates in VLAN load balancing in the segment. REP VLAN load balancing is achieved by blocking some VLANs at a configured alternate port and all other VLANs at the primary edge port.



Note When VLAN load balancing is configured, it does not start working until triggered by either manual intervention or a link failure and recovery.

When VLAN load balancing is triggered, the primary edge port then sends out a message to alert all interfaces in the segment about the preemption. When the message is received by the secondary edge port, it is reflected into the network to notify the alternate port to block the set of VLANs specified in the message and to notify the primary edge port to block the remaining VLANs.

You can also configure a particular port in the segment to block all VLANs. VLAN load balancing is initiated only by the primary edge port and is not possible if the segment is not terminated by an edge port on each end. The primary edge port determines the local VLAN load balancing configuration.

NTP-J14 Configure VLAN Load Balancing

Purpose	This procedure configures VLAN load balancing.
Tools/Equipment	None

Prerequisite Procedures	None
Required/As Needed	As needed
Onsite/Remote	Onsite or remote
Security Level	Provisioning or higher

Procedure

Perform any of the following procedures as needed:

- [DLP-J38 Configure VLAN Load Balancing on the Primary Edge Port Using Cisco IOS Commands, on page 21](#)
- [DLP-J39 Configure the Preemption for VLAN Load Balancing Using Cisco IOS Commands, on page 23](#)
- [DLP-J40 Activate VLAN Load Balancing Using CTC, on page 24](#)
- [DLP-J41 Deactivate VLAN Load Balancing Using CTC, on page 25](#)

Stop. You have completed this procedure.

DLP-J38 Configure VLAN Load Balancing on the Primary Edge Port Using Cisco IOS Commands

Purpose	This procedure configures VLAN load balancing on the primary edge port using Cisco IOS commands.
Tools/Equipment	None
Prerequisite Procedures	DLP-J31 Enable REP on a Port Using Cisco IOS Commands, on page 13
Required/As Needed	As needed
Onsite/Remote	Onsite or remote
Security Level	Provisioning or higher

Procedure

	Command or Action	Purpose
Step 1	enable Example:	Enables privileged EXEC mode. • Enter your password if prompted.

	Command or Action	Purpose
	Router> enable	
Step 2	configure terminal Example: Router# configure terminal	Enters global configuration mode.
Step 3	interface <i>interface-id</i> Example: Router(config)# interface TenGigabitEthernet4/1	Specifies the interface and enters the interface configuration mode.
Step 4	rep block port { <i>id port-id</i> <i>neighbor-offset</i> preferred } vlan { <i>vlan-list</i> all } Example: Router(config-if)# rep block port 0009001818D68700 vlan all	Configures VLAN load balancing on the primary edge port, identifies the REP alternate port, and configures the VLANs to be blocked on the alternate port. <ul style="list-style-type: none"> • Enter the id <i>port-id</i> to identify the alternate port by port ID. The port ID is automatically generated for each port in the segment. You can view interface port IDs by entering the show interface interface-id rep detail command in privileged EXEC mode. • Enter a <i>neighbor-offset</i> number to identify the alternate port as a downstream neighbor from an edge port. The range is from –256 to 256, with negative numbers indicating the downstream neighbor from the secondary edge port. A value of 0 is invalid. Enter -1 to identify the secondary edge port as the alternate port. • Enter preferred to select the regular segment port previously identified as the preferred alternate port for VLAN load balancing. • Enter vlan <i>vlan-list</i> to block one VLAN or a range of VLANs. • Enter vlan all to block all the VLANs.
Step 5	end Example: Router(config-if)# end	Returns to privileged EXEC mode.
Step 6	Return to your originating procedure (NTP).	—

DLP-J39 Configure the Preemption for VLAN Load Balancing Using Cisco IOS Commands

Purpose	This procedure configures the preemption for VLAN load balancing using Cisco IOS commands.
Tools/Equipment	None
Prerequisite Procedures	DLP-J38 Configure VLAN Load Balancing on the Primary Edge Port Using Cisco IOS Commands, on page 21
Required/As Needed	As needed
Onsite/Remote	Onsite or remote
Security Level	Provisioning or higher

Ensure that all the other segment configuration has been completed before setting preemption for VLAN load balancing. When you enter the **rep preempt segment *segment-id*** command, a confirmation message appears before the command is executed because preemption for VLAN load balancing can disrupt the network.

If you do not enter the **rep preempt delay *seconds*** interface configuration command on the primary edge port to configure a preemption time delay, the default configuration is to manually trigger VLAN load balancing on the segment. Use the **show rep topology** privileged EXEC command to see which port in the segment is the primary edge port.

Perform these steps on the router that has the segment with the primary edge port.

Procedure

	Command or Action	Purpose
Step 1	enable Example: Router> enable	Enables privileged EXEC mode. Enter your password if prompted.
Step 2	rep preempt segment <i>segment-id</i> Example: Router# rep preempt segment 1	Manually triggers VLAN load balancing on the segment. Note Confirm the action before the command is executed.
Step 3	show rep topology Example: Router# show rep topology	Displays the REP topology information.
Step 4	Return to your originating procedure (NTP).	—

Example: Configure the Preemption for VLAN Load Balancing

The following example shows how to set the preemption for VLAN load balancing on a REP segment using Cisco IOS commands.

```
Router> enable
Router# rep preempt segment 1
```

DLP-J40 Activate VLAN Load Balancing Using CTC

Purpose	This procedure activates VLAN load balancing using CTC.
Tools/Equipment	None
Prerequisite Procedures	DLP-J34 Create a Segment Using CTC, on page 17
Required/As Needed	As needed
Onsite/Remote	Onsite or remote
Security Level	Provisioning or higher



Note When VLAN load balancing is activated, the default configuration is manual preemption with the delay timer disabled.

Procedure

- Step 1** Complete the [NTP-J22 Log into CTC](#) procedure at a node where you want to activate VLAN load balancing.
- Step 2** From the View menu, choose **Go to Home View**.
- Step 3** Right-click the fabric or line card and choose **Open Packet Transport System View**. The Packet Transport System View dialog box appears.
- Step 4** Click the **Provisioning** tab.
- Step 5** From the left pane, click **REP**.
- Step 6** Click the **Segment** tab. The list of segments appear.
- Step 7** Choose a segment from the list of segments.
- Step 8** Click **Activate VLB** to activate VLAN load balancing.
- Step 9** Return to your originating procedure (NTP).

DLP-J41 Deactivate VLAN Load Balancing Using CTC

Purpose	This procedure deactivates VLAN load balancing using CTC.
Tools/Equipment	None
Prerequisite Procedures	DLP-J34 Create a Segment Using CTC , on page 17
Required/As Needed	As needed
Onsite/Remote	Onsite or remote
Security Level	Provisioning or higher

Procedure

- Step 1** Complete the [NTP-J22 Log into CTC](#) procedure at a node where you want to deactivate VLAN load balancing.
- Step 2** From the View menu, choose **Go to Home View**.
- Step 3** Right-click the fabric or line card and choose **Open Packet Transport System View**. The Packet Transport System View dialog box appears.
- Step 4** Click the **Provisioning** tab.
- Step 5** From the left pane, click **REP**.
- Step 6** Click the **Segment** tab. The list of segments appear.
- Step 7** Choose a segment from the list of segments.
- Step 8** Click **Deactivate VLB** to deactivate VLAN load balancing.
- Step 9** Return to your originating procedure (NTP).

Understanding REP Configurable Timers

The REP Configurable Timer (REP Fast Hellos) feature provides a fast reconvergence in a ring topology with higher timer granularity and quicker failure detection on the remote side. This feature also supports improved convergence of REP segments having nodes with copper based SFPs, where the link detection time varies between 300 ms to 700 ms.

With the REP Link Status Layer (LSL) ageout timer configuration, the failure detection time can be configured between a range of 120 to 10000 ms, in multiples of 40 ms. The result of this configuration is that, even if the copper pull takes about 700 ms to notify the remote end about the failure, the REP configurable timers process will detect it much earlier and take subsequent action for the failure recovery within 200 ms.

The LSL retries and LSL ageout timer is related in terms of LSL hello packet transmission. The LSL hello packet interval is measured by `lsl_age_timer/lsl_retries` value. The LSL hello packet interval value must be at least 40 ms.

Restrictions and Usage Guidelines

Follow these guidelines and restrictions:

- While configuring REP configurable timers, we recommend that you shut the port, configure REP and only then use the **no shut** command. This prevents the REP from flapping and generating large number of internal messages.
- If incompatible switches are neighbors, configure the correct LSL Age Out value first. In some scenarios, you might not get the expected convergence range.
- While configuring REP configurable timers, we recommend that you configure the REP LSL number of retries first and then configure the REP LSL ageout timer value.

NTP-J15 Configure REP Timers

Purpose	This procedure configures REP timers.
Tools/Equipment	None
Prerequisite Procedures	None
Required/As Needed	As needed
Onsite/Remote	Onsite or remote
Security Level	Provisioning or higher

Procedure

Perform any of the following procedures as needed:

- [DLP-J42 Configure REP Link Status Layer Retries Using Cisco IOS Commands](#), on page 26
- [DLP-J43 Configure the REP Link Status Layer Ageout Timer Using Cisco IOS Commands](#), on page 28

Stop. You have completed this procedure.

DLP-J42 Configure REP Link Status Layer Retries Using Cisco IOS Commands

Purpose	This procedure configures REP LSL retries at the interface configuration level using Cisco IOS commands.
Tools/Equipment	None
Prerequisite Procedures	DLP-J31 Enable REP on a Port Using Cisco IOS Commands , on page 13

Required/As Needed	As needed
Onsite/Remote	Onsite or remote
Security Level	Provisioning or higher

Procedure

	Command or Action	Purpose
Step 1	enable Example: Router> enable	Enables privileged EXEC mode. • Enter your password if prompted.
Step 2	configure terminal Example: Router# configure terminal	Enters global configuration mode.
Step 3	interface <i>type number</i> Example: Router(config)# interface TenGigabitEthernet4/1	Specifies the interface to configure and enters interface configuration mode.
Step 4	rep lsl-retries <i>no-of-retries</i> Example: Router(config-if)# rep lsl-retries 4	Configures the number of retries before the REP link is disabled. The range of retries is from 3 to 10. The default number of LSL retries is 5.
Step 5	end Example: Router(config-if)# end	Returns to privileged EXEC mode.
Step 6	Return to your originating procedure (NTP).	—

Example: Configure REP Link Status Layer Retries

The following example shows how to configure REP LSL retries using Cisco IOS commands.

```
Router# enable
Router# configure terminal
Router(config)# interface TenGigabitEthernet4/1
Router(config-if)# rep segment 2 edge primary
Router(config-if)# rep lsl-retries 4
Router(config-if)# end
```

DLP-J43 Configure the REP Link Status Layer Ageout Timer Using Cisco IOS Commands

Purpose	This procedure configures REP LSL ageout timer at the interface configuration level using Cisco IOS commands.
Tools/Equipment	None
Prerequisite Procedures	<ul style="list-style-type: none"> • DLP-J31 Enable REP on a Port Using Cisco IOS Commands, on page 13 • DLP-J42 Configure REP Link Status Layer Retries Using Cisco IOS Commands, on page 26
Required/As Needed	As needed
Onsite/Remote	Onsite or remote
Security Level	Provisioning or higher

Procedure

	Command or Action	Purpose
Step 1	enable Example: Router> enable	Enables privileged EXEC mode. <ul style="list-style-type: none"> • Enter your password if prompted.
Step 2	configure terminal Example: Router# configure terminal	Enters global configuration mode.
Step 3	interface <i>type number</i> Example: Router(config)# interface TenGigabitEthernet4/1	Specifies the interface to configure and enters interface configuration mode.
Step 4	rep lsl-age-timer <i>lsl-age-timer</i> Example: Router(config-if)# rep lsl-age-timer 2000	Configures REP link status layer ageout timer value. The range of <i>lsl-age-timer</i> is between 120 ms and 10000 ms, in multiples of 40 ms. The default LSL ageout timer value is 5 seconds. The recommended LSL ageout timer value is 2 seconds.

	Command or Action	Purpose
Step 5	end Example: Router(config-if)# end	Returns to privileged EXEC mode.
Step 6	Return to your originating procedure (NTP).	—

Example: Configure the REP LSL Ageout Timer

The following example shows how to configure REP LSL ageout timer value using Cisco IOS commands.

```
Router# enable
Router# configure terminal
Router(config)# interface TenGigabitEthernet4/1
Router(config-if)# rep segment 1 edge primary
Router(config-if)# rep lsl-age-timer 2000
Router(config-if)# end
```

Understanding REP with EVC

REP can be integrated with an Ethernet Virtual Circuit (EVC) port using the REP over EVC feature. This feature allows you to configure and manage ports at the service instance level. An EVC port can have multiple service instances. Each service instance corresponds to a unique Ethernet Flow Point (EFP).

This feature allows you to configure an EVC port to participate in a REP segment. REP can selectively block or forward data traffic on particular VLANs. For EVC, the VLAN ID refers to the outer tag of the encapsulation that is configured on a service instance.



Note

REP is supported on an EVC cross-connect and bridge domain service. REP is not supported for Ethernet Private Line and Ethernet Virtual Private Line services.

REP does not support protection or loop prevention on ring interfaces which have one of the following EFP configurations:

- **encapsulation default**
- **encapsulation untagged**
- **encapsulation xxxx any**

Though a REP ring will converge with such interfaces, traffic loop can happen depending on the EVC configuration.

Using the REP over EVC feature, you can:

- Control data traffic.
- Configure VLAN load balancing.

Restrictions and Usage Guidelines

When configuring REP over EVC, follow these guidelines and restrictions:

- It is recommended that you begin by configuring one port and then configure the contiguous ports to minimize the number of segments and the number of blocked ports.
- REP is not supported on LACP.
- If more than two ports in a segment fail when no external neighbors are configured, one port goes into a forwarding state to maintain connectivity during configuration.
- To avoid misconfiguration, you must configure all the trunk ports in the segment with the same set of allowed VLANs.
- Because REP blocks all VLANs until another REP interface sends a message to unblock it, you might lose connectivity to the port. This happens if you enable REP in a telnet session that accesses the EVC port through the same interface.
- On a router if REP is enabled on two ports for a segment, both ports must either be a regular segment ports or edge ports. REP ports follow these rules on a router:
 - If only one port is configured in a segment, the port should be an edge port.
 - If two ports belong to the same segment, both ports must be edge ports or the regular segment ports.
 - If two ports belong to the same segment and one is configured as an edge port and other as a regular segment port, the edge port is treated as a regular segment port.
 - There can be only two edge ports in a segment; if there are two edge routers in a segment, each router can have only one edge port. All the other ports on the edge router function as normal ports.
- REP interfaces come up in a blocked state and remains in a blocked state until notified that it is safe to unblock.
- REP relays all LSL Protocol Data Units (PDUs) in untagged frames and only HFL packets are relayed on the administrative VLAN.
- REP is not supported on EtherChannels. It is supported on EVC port-channels. REP is implemented on port-channels instead of its individual member links.
- REP is not supported on static port-channels.
- In case of double VLAN tagged frame, REP is implemented only on the outer VLAN tag.
- When an edge no-neighbor is configured on a router, configuring and unconfiguring an edge port is not allowed.

NTP-J16 Configure REP over EVC

Purpose	This procedure configures REP over EVC.
Tools/Equipment	None
Prerequisite Procedures	None

Required/As Needed	As needed
Onsite/Remote	Onsite or remote
Security Level	Provisioning or higher

Procedure

Perform any of the following procedures as needed:

- [DLP-J44 Configure REP over EVC Using a Cross-Connect Using Cisco IOS Commands](#), on page 31
- [DLP-J45 Configure REP over EVC Using the Bridge Domain Using Cisco IOS Commands](#), on page 34

Stop. You have completed this procedure.

DLP-J44 Configure REP over EVC Using a Cross-Connect Using Cisco IOS Commands

Purpose	This procedure configures REP over EVC using a cross-connect at the service instance level using Cisco IOS commands.
Tools/Equipment	None
Prerequisite Procedures	None
Required/As Needed	As needed
Onsite/Remote	Onsite or remote
Security Level	Provisioning or higher

Procedure

	Command or Action	Purpose
Step 1	enable Example: Router> enable	Enables privileged EXEC mode. • Enter your password if prompted.
Step 2	configure terminal Example: Router# configure terminal	Enters global configuration mode.

	Command or Action	Purpose
Step 3	interface <i>type number</i> Example: Router(config)# interface TenGigabitEthernet4/1	Specifies the interface to configure and enters the interface configuration mode.
Step 4	ether vlan color-block all Example: Router(config-if)# ether vlan color-block all	Configures REP to block cross-connect type of service instances.
Step 5	service instance <i>id ethernet [evc-id]</i> Example: Router(config-if)# service instance 101 ethernet	Configures an Ethernet service instance on an interface and enters the service instance configuration mode.
Step 6	encapsulation dot1q <i>{any vlan-id [vlan-id [-vlan-id]]}</i> second-dot1q <i>{any vlan-id [vlan-id [-vlan-id]]}</i> Example: Router(config-if-srv)# encapsulation dot1q 100 second-dot1q 200	Configures the encapsulation. Defines the matching criteria to be used to map ingress dot1q frames on an interface to the appropriate service instance.
Step 7	rewrite ingress tag <i>{push {dot1q vlan-id dot1q vlan-id second-dot1q vlan-id dot1ad vlan-id dot1q vlan-id} pop {1 2} translate {1-to-1 {dot1q vlan-id dot1ad vlan-id} 2-to-1 dot1q vlan-id dot1ad vlan-id} 1-to-2 {dot1q vlan-id second-dot1q vlan-id dot1ad vlan-id dot1q vlan-id} 2-to-2 {dot1q vlan-id second-dot1q vlan-id dot1ad vlan-id dot1q vlan-id}} {symmetric}</i> Example: Router(config-if-srv)# rewrite ingress tag dot1q single symmetric	Specifies the rewrite operation to be applied on the frame ingress to the service instance.
Step 8	xconnect <i>loopback_id vc_id encapsulation mpls</i> Example: Router(config-if-srv)# xconnect 10.0.0.2 999 encapsulation mpls	Configures the forwarding mechanism on a service instance. Ensure that the MPLS connectivity is up.
Step 9	rep segment <i>segment-id [edge [no-neighbor] [primary]] [preferred]</i> Example:	Configures REP over EVC. The segment ID range is from 1 to 1024. Note You must configure a primary and secondary edge port on each segment.

	Command or Action	Purpose
	Router(config-if)# rep segment 3 edge	<p>The following optional keywords are available.</p> <ul style="list-style-type: none"> • Enter edge to configure the port as an edge port. Entering edge without the primary keyword configures the port as the secondary edge port. Each segment has only two edge ports. • Enter no-neighbor to specify that the edge port must not have a neighbor port. • Enter primary to configure the port as the primary edge port where you can configure VLAN load balancing. • Enter preferred to indicate that the port is the preferred alternate port or the preferred port for VLAN load balancing. <p>Note Configuring a port as preferred does not guarantee that it becomes the alternate port; it merely gives it a slight edge among equal contenders. The alternate port is usually a previously failed port.</p>
Step 10	<p>exit</p> <p>Example: Router(config-if)# exit</p>	Exits interface configuration mode.
Step 11	Return to your originating procedure (NTP).	—

Example: Configure REP over EVC Using Cross-Connect

The following example shows how to configure REP over EVC using cross-connect.

```
Router# enable
Router# configure terminal
Router(config)# interface TenGigabitEthernet4/1
Router(config-if)# service instance 10 ethernet
Router(config-srv)# encapsulation dot1q 20
Router(config-if-srv)# rewrite ingress tag push dot1q 20 symmetric
Router(config-if-srv)# xconnect 10.0.0.2 999 encapsulation MPLS
Router(config-if-srv)# exit
Router(config-if)# rep segment 2 edge
Router(config-if)# end
```

DLP-J45 Configure REP over EVC Using the Bridge Domain Using Cisco IOS Commands

Purpose	This procedure configures REP over EVC using the bridge domain at the service instance level using Cisco IOS commands.
Tools/Equipment	None
Prerequisite Procedures	None
Required/As Needed	As needed
Onsite/Remote	Onsite or remote
Security Level	Provisioning or higher

Procedure

	Command or Action	Purpose
Step 1	enable Example: Router> enable	Enables privileged EXEC mode. • Enter your password if prompted.
Step 2	configure terminal Example: Router# configure terminal	Enters global configuration mode.
Step 3	interface <i>type number</i> Example: Router(config)# interface TenGigabitEthernet4/1	Specifies the interface to configure and enters interface configuration mode.
Step 4	service instance <i>id ethernet [evc-id]</i> Example: Router(config-if)# service instance 101 ethernet	Configures an Ethernet service instance on an interface and enters service instance configuration mode.
Step 5	encapsulation dot1q <i>{any vlan-id [vlan-id [-vlan-id]]}</i> second-dot1q <i>{any vlan-id [vlan-id [-vlan-id]]}</i> Example: Router(config-if-srv)# encapsulation dot1q 100 second dot1q 200	Configures the encapsulation. Defines the matching criteria to be used in order to map ingress dot1q frames on an interface to the appropriate service instance.

	Command or Action	Purpose
Step 6	<pre>rewrite ingress tag {push {dot1q vlan-id dot1q vlan-id second-dot1q vlan-id dot1ad vlan-id dot1q vlan-id} pop {1 2} translate {1-to-1 {dot1q vlan-id dot1ad vlan-id} 2-to-1 dot1q vlan-id dot1ad vlan-id} 1-to-2 {dot1q vlan-id second-dot1q vlan-id dot1ad vlan-id dot1q vlan-id} 2-to-2 {dot1q vlan-id second-dot1q vlan-id dot1ad vlan-id dot1q vlan-id}} {symmetric}</pre> <p>Example: Router(config-if-srv)# rewrite ingress tag push dot1q 20</p>	Specifies the rewrite operation to be applied on the frame ingress to the service instance.
Step 7	<pre>bridge-domain bridge-id [split-horizon]</pre> <p>Example: Router(config-if-srv)# bridge-domain 10</p>	Configures the bridge domain to add another VLAN tag of type bridge-domain to the incoming packet.
Step 8	<pre>exit</pre> <p>Example: Router(config-if-srv)# exit</p>	Exits service instance configuration mode.
Step 9	<pre>rep segment segment-id [edge [no-neighbor] [primary]] [preferred]</pre> <p>Example: Router(config-if)# rep segment 2 edge primary</p>	<p>Configures REP over EVC. The segment ID range is from 1 to 1024.</p> <p>Note You must configure a primary and secondary edge port on each segment. The following optional keywords are available.</p> <ul style="list-style-type: none"> • Enter edge to configure the port as an edge port. Entering edge without the primary keyword configures the port as the secondary edge port. Each segment has only two edge ports. • Enter no-neighbor to specify that the edge port must not have a neighbor port. • Enter primary to configure the port as the primary edge port where you can configure VLAN load balancing. • Enter preferred to indicate that the port is the preferred alternate port or the preferred port for VLAN load balancing.

	Command or Action	Purpose
		Note Configuring a port as preferred does not guarantee that it becomes the alternate port; it merely gives it a slight edge among equal contenders. The alternate port is usually a previously failed port.
Step 10	exit Example: Router(config-if)# exit	Exits interface configuration mode.
Step 11	Return to your originating procedure (NTP).	—

Example: Configure REP over EVC Using the Bridge Domain

The following example shows how to configure REP over EVC using the bridge domain.

```
Router# enable
Router# configure terminal
Router(config)# interface TenGigabitEthernet4/1
Router(config-if)# service instance 10 ethernet
Router(config-if-srv)# encapsulation dot1q 10
Router(config-if-srv)# rewrite ingress tag push dot1q 10 symmetric
Router(config-if-srv)# bridge-domain 100
Router(config-if-srv)# exit
Router(config-if)# rep segment 2 edge
Router(config-if)# end
```

Verify REP with EVC Configuration Using Cisco IOS Commands

You can use the **show rep topology**, **show rep topology detail** and **show interface rep** commands to verify REP over EVC configuration.

Example of the show rep topology Command

```
Router# show rep topology
```

```
REP Segment 1
BridgeName      PortName      Edge Role
-----
10.64.106.63   Te5/4        Pri  Open
10.64.106.228  Te3/4        Open
10.64.106.228  Te3/3        Open
10.64.106.67   Te4/3        Open
10.64.106.67   Te4/4        Alt
10.64.106.63   Te4/4        Sec  Open

REP Segment 3
```

BridgeName	PortName	Edge	Role
10.64.106.63	Gi50/1	Pri	Open
SVT_3400_2	Gi0/3		Open
SVT_3400_2	Gi0/4		Open
10.64.106.68	Gi40/2		Open
10.64.106.68	Gi40/1		Open
10.64.106.63	Gi50/2	Sec	Alt

Example of the show rep topology detail Command

```
Router# show rep topology detail
```

```
REP Segment 1
10.64.106.63, Te5/4 (Primary Edge)
  Open Port, all vlans forwarding
  Bridge MAC: 0005.9b2e.1700
  Port Number: 010
  Port Priority: 000
  Neighbor Number: 1 / [-6]
10.64.106.228, Te3/4 (Intermediate)
  Open Port, all vlans forwarding
  Bridge MAC: 0005.9b1b.1f20
  Port Number: 010
  Port Priority: 000
  Neighbor Number: 2 / [-5]
10.64.106.228, Te3/3 (Intermediate)
  Open Port, all vlans forwarding
  Bridge MAC: 0005.9b1b.1f20
  Port Number: 00E
  Port Priority: 000
  Neighbor Number: 3 / [-4]
10.64.106.67, Te4/3 (Intermediate)
  Open Port, all vlans forwarding
  Bridge MAC: 0005.9b2e.1800
  Port Number: 008
  Port Priority: 000
  Neighbor Number: 4 / [-3]
10.64.106.67, Te4/4 (Intermediate)
  Alternate Port, some vlans blocked
  Bridge MAC: 0005.9b2e.1800
  Port Number: 00A
  Port Priority: 000
  Neighbor Number: 5 / [-2]
10.64.106.63, Te4/4 (Secondary Edge)
  Open Port, all vlans forwarding
  Bridge MAC: 0005.9b2e.1700
  Port Number: 00A
  Port Priority: 000
  Neighbor Number: 6 / [-1]
```

Example of the show interface rep detail Command

```
Router# show interface TenGigabitEthernet4/1 rep detail
```

```

TenGigabitEthernet4/1 REP enabled
Segment-id: 3 (Primary Edge)
PortID: 03010015FA66FF80
Preferred flag: No
Operational Link Status: TWO_WAY
Current Key: 02040015FA66FF804050
Port Role: Open
Blocked VLAN: <empty>
Admin-vlan: 1
Preempt Delay Timer: disabled
Configured Load-balancing Block Port: none
Configured Load-balancing Block VLAN: none
STCN Propagate to: none
LSL PDU rx: 999, tx: 652
HFL PDU rx: 0, tx: 0
BPA TLV rx: 500, tx: 4
BPA (STCN, LSL) TLV rx: 0, tx: 0
BPA (STCN, HFL) TLV rx: 0, tx: 0
EPA-ELECTION TLV rx: 6, tx: 5
EPA-COMMAND TLV rx: 0, tx: 0
EPA-INFO TLV rx: 135, tx: 136

```

REP with Other Features

REP supports up to 32 segments in each node. REP supports up to 5 segments or 10 ports on a single card or CPT 50 panel.

REP with High Availability

When the active fabric card fails, REP supports hot switchover to the standby fabric card. There might be momentary loss of traffic when the standby fabric card takes over as the active fabric card.

REP with Multicast

In a REP ring, the multicast traffic may not flow across all the elements on the ring; the traffic depends on the path taken from the multicast router to the client. The elements that do not form the multicast path do not become members of the multicast group.

When there is a failure in a REP ring, it is possible that the new path between the multicast router and the client may traverse elements which were previously not part of the multicast traffic path. These elements do not forward multicast traffic till they see a query from multicast router and a join from the client. A multicast router may only send query after long intervals, which results in a large traffic hit. All the ports that are enabled with REP must be configured as static mrouter ports to solve this issue.