



Alarm Propagation Scenarios

In an optical network, alarm propagation defines how different alarms propagate in a larger link during any failure in the network. The alarm correlation algorithm suppresses the lower-priority alarms on each device in the network. Hence, the network administrator can assess the health of the optical network and detect the root cause of the problem by focusing only on the significant alarms on the node.

This chapter covers the alarms that are active and suppressed during the common alarm propagation scenarios when operating the NCS1K4-2.4T-K9 line card of the NCS 1014 chassis.

- [Client Unidirectional Receiver Fiber Cut , on page 1](#)
- [Client Unidirectional Transmitter Fiber Cut , on page 2](#)
- [Client Bi-directional Fiber Cut , on page 3](#)
- [Client Unidirectional Loss of Synchronization on Data Interface , on page 4](#)
- [Client Unidirectional LOCAL FAULT, on page 5](#)
- [Client Unidirectional REMOTE-FAULT, on page 6](#)
- [Client Unidirectional High Symbol Error Rate , on page 7](#)
- [Client Unidirectional Degraded Symbol Error Rate , on page 8](#)
- [Client Unidirectional LOCAL-DEG-SER , on page 9](#)
- [Client Unidirectional REMOTE-DEG-SER, on page 10](#)
- [Client Unidirectional Improper Removal, on page 11](#)
- [Trunk Unidirectional Fiber Cut , on page 12](#)
- [Trunk Bidirectional Fiber Cut , on page 13](#)
- [Trunk Frequency Mismatch - Complete Offset with 150GHz Spacing, on page 15](#)
- [Trunk Frequency Mismatch - Partial Offset with 75GHz Spacing, on page 15](#)
- [Trunk Unidirectional Loss of Frame, on page 17](#)
- [Trunk Group ID Mismatch , on page 18](#)
- [Trunk Unidirectional OTUK-TIM, on page 19](#)
- [Trunk Unidirectional Improper Removal, on page 20](#)

Client Unidirectional Receiver Fiber Cut

When there is a client unidirectional receiver fiber cut between Router-1 and 2.4T line card-1, alarms are raised and suppressed at the respective ports of each node.

This figure displays a client unidirectional receiver fiber cut.

Figure 1: Client Unidirectional Receiver Fiber Cut

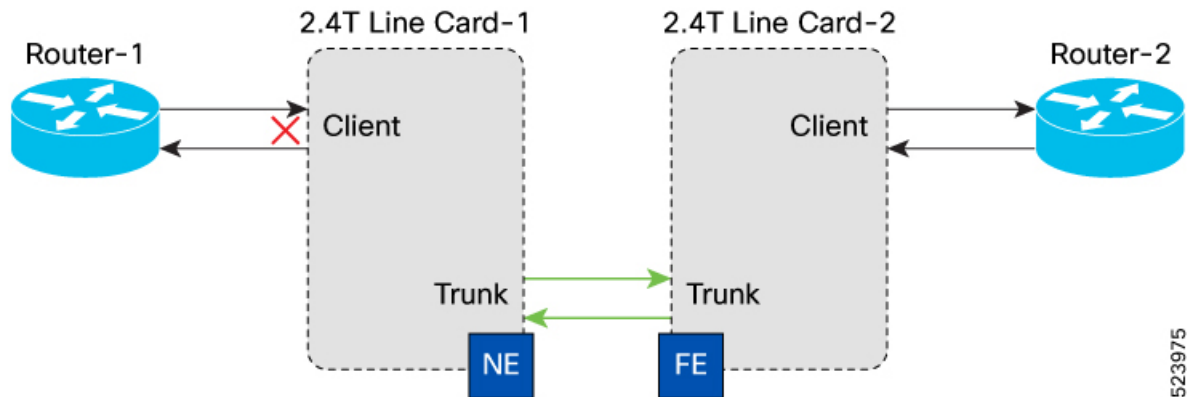

523975

These tables list the alarms raised at the respective ports of each node.

Table 1: Active and Suppressed Alarms for Near End (NE) Interface Faults

NE Interfaces	Active Alarms	Suppressed Alarms
Router 1	Remote Fault	No Alarms
NE_Client	SIGLOSS	No Alarms
NE_Trunk	No Alarms	No Alarms

Table 2: Active and Suppressed Alarms for Far End (FE) Interface Faults

FE Interfaces	Active Alarms	Suppressed Alarms
Router 2	<ul style="list-style-type: none"> Local Fault LOCAL-DEG-SER 	No Alarms
FE_Client	Remote Fault	No Alarms
FE_Trunk	OPUK-CSF	No Alarms

¹ The capability of the router is the determining factor for LD (LOCAL-DEG-SER) reporting. According to IEEE Standard 802.3, implementing Forward Error Correction (FEC) alarms is optional. However, if these alarms are supported, the router inserts an RD (Remote-Deg-Ser) in the upstream direction in response to the LD (Local-FEC -Deg-Ser) alarm.

Client Unidirectional Transmitter Fiber Cut

When there is a client unidirectional transmitter fiber cut between Router-1 and 2.4T Line Card-1, alarms are raised and suppressed at the respective ports of each node.

This figure displays the client unidirectional transmitter fiber cut.

Figure 2: Client Unidirectional Transmitter Fiber Cut

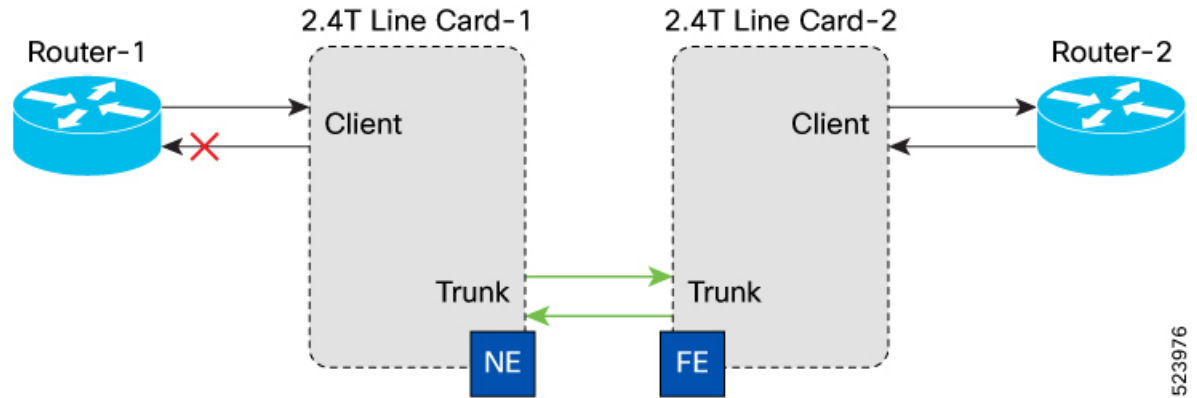

523976

The following tables list the alarms that are raised at the respective ports of each node.

Table 3: Active and Suppressed Alarms for Near End (NE) Interface Faults

Node	Active Alarms	Suppressed Alarms
Router 1	LOSS	No Alarms
NE_Client	Remote Fault	No Alarms
NE_Trunk	No Alarms	No Alarms

Table 4: Active and Suppressed Alarms for Far End (FE) Interface Faults

Node	Active Alarms	Suppressed Alarms
Router 2	Remote Fault	No Alarms
FE_Client	No Alarms	No Alarms
FE_Trunk	No Alarms	No Alarms

Client Bi-directional Fiber Cut

When there is a client bi-directional fiber cut between Router-1 and 2.4T Line Card-1, alarms are raised and suppressed at the respective ports of each node.

This figure displays a client bi-directional receiver fiber cut.

Figure 3: Client Bi-directional Fiber Cut

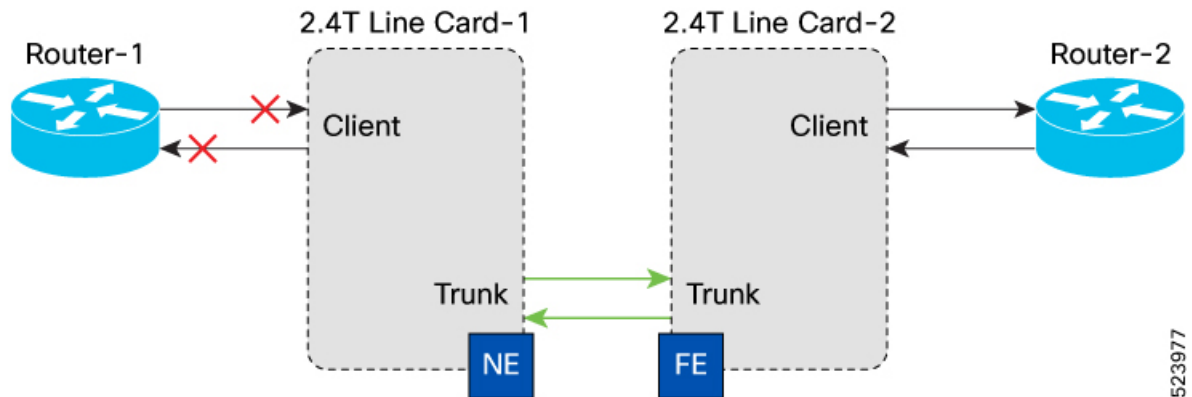

523977

These tables list the alarms that are raised at the respective ports of each node.

Table 5: Active and Suppressed Alarms for Near End (NE) Interface Faults

Node	Active Alarms	Suppressed Alarms
Router 1	LOSS	No Alarms
NE_Client	SIGLOSS	No Alarms
NE_Trunk	No Alarms	No Alarms

Table 6: Active and Suppressed Alarms for Far End (FE) Interface Faults

Node	Active Alarms	Suppressed Alarms
Router 2	<ul style="list-style-type: none"> Local Fault LD² 	No Alarms
FE_Client	Remote Fault	No Alarms
FE_Trunk	OPUK-CSF	No Alarms

² The capability of the router is the determining factor for LD (LOCAL-DEG-SER) reporting. According to IEEE Standard 802.3, implementing Forward Error Correction (FEC) alarms is optional. However, if these alarms are supported, the router inserts an RD (Remote-Deg-Ser) in the upstream direction in response to the LD (Local-FEC -Deg-Ser) alarm.

Client Unidirectional Loss of Synchronization on Data Interface

When there is a client unidirectional Loss of Synchronization on Data Interface (SYNCLOSS) between Router-1 and 2.4T line card-1, alarms are raised and suppressed at the respective ports of each node.

This figure displays the unidirectional SYNCLOSS.

Figure 4: Client Unidirectional SYNCLOSS

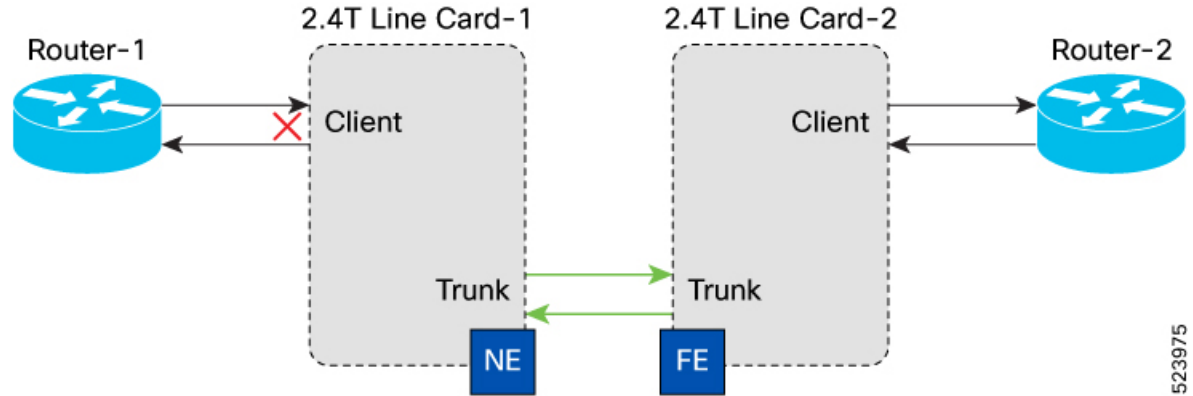

523975

These tables list the alarms that are raised and suppressed at the respective ports of each node.

Table 7: Active and Suppressed Alarms for Near End (NE) Interface Faults

Node	Active Alarms	Suppressed Alarms
Router 1	Remote Fault	No Alarms
NE_Client	SYNCLOSS	No Alarms
NE_Trunk	No Alarms	No Alarms

Table 8: Active and Suppressed Alarms for Far End (FE) Interface Faults

Node	Active Alarms	Suppressed Alarms
Router 2	<ul style="list-style-type: none"> Local Fault LOCAL-DEG-SER³ 	No Alarms
FE_Client	Remote Fault	No Alarms
FE_Trunk	OPUK-CSF	No Alarms

³ The capability of the router is the determining factor for LD (LOCAL-DEG-SER) reporting. According to IEEE Standard 802.3, implementing Forward Error Correction (FEC) alarms is optional. However, if these alarms are supported, the router inserts an RD (Remote-Deg-Ser) in the upstream direction in response to the LD (Local-FEC -Deg-Ser) alarm.

Client Unidirectional LOCAL FAULT

When there is a client unidirectional LOCAL FAULT (LF) between Router-1 and 2.4T Line Card-1, alarms are raised and suppressed at the respective ports of each node.

This figure displays unidirectional LF.

Figure 5: Client Unidirectional LF

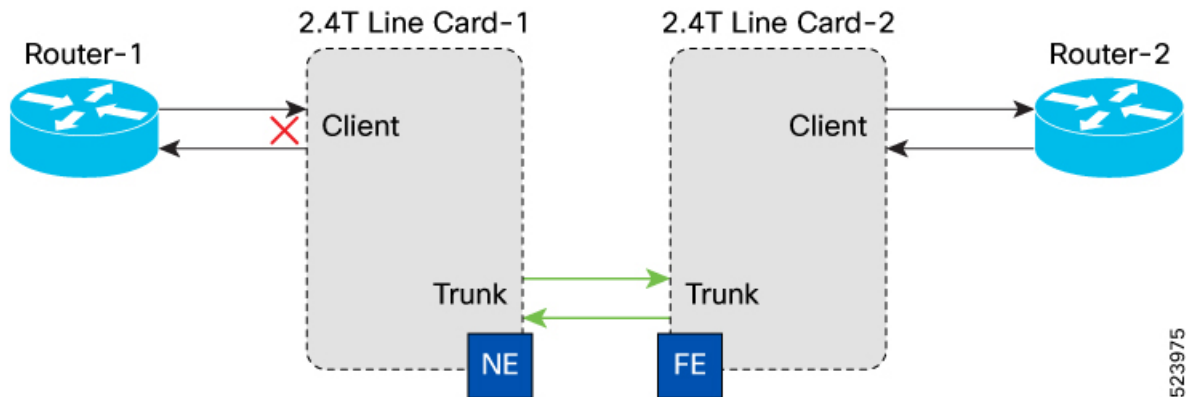

523975

These tables list the alarms that are raised and suppressed at the respective ports of each node.

Table 9: Active and Suppressed Alarms for Near End (NE) Interface Faults

Node	Active Alarms	Suppressed Alarms
Router 1	Remote Fault	No Alarms
NE_Client	Local Fault	No Alarms
NE_Trunk	No Alarms	No Alarms

Table 10: Active and Suppressed Alarms for Far End (FE) Interface Faults

Node	Active Alarms	Suppressed Alarms
Router 2	Local Fault	No Alarms
FE_Client	Remote Fault	No Alarms
FE_Trunk	No Alarms	No Alarms

Client Unidirectional REMOTE-FAULT

When there is a client unidirectional REMOTE-FAULT (RF) between Router-1 and 2.4T Line Card-1, alarms are raised and suppressed at the respective ports of each node.

This figure displays unidirectional RF.

Figure 6: Client Unidirectional RF

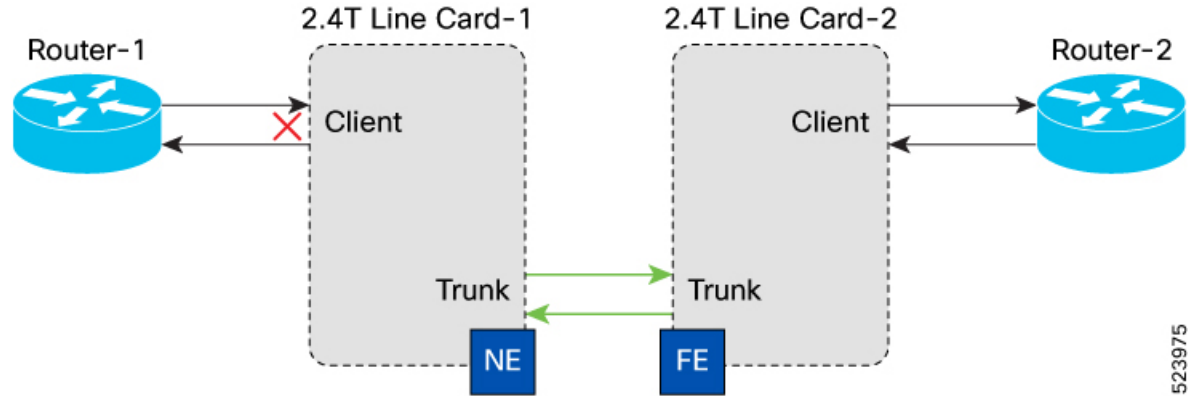

523975

These tables list the alarms that are raised and suppressed at the respective ports of each node:

Table 11: Active and Suppressed Alarms for Near End (NE) Interface Faults

Node	Active Alarms	Suppressed Alarms
Router 1	Any fault can be triggered (In case of LOSS/LF, Remote fault is triggered).	No Alarms
NE_Client	Remote Fault	No Alarms
NE_Trunk	No Alarms	No Alarms

Table 12: Active and Suppressed Alarms for Far End (FE) Interface Faults

Node	Active Alarms	Suppressed Alarms
Router 2	Remote Fault	No Alarms
FE_Client	No Alarms	No Alarms
FE_Trunk	No Alarms	No Alarms

Client Unidirectional High Symbol Error Rate

When there is a client unidirectional High Symbol Error Rate (Hi-SER) between Router-1 and 2.4T Line Card-1, alarms are raised and suppressed at the respective ports of each node.

This figure displays client unidirectional Hi-SER fault.

Figure 7: Client Unidirectional HI-SER

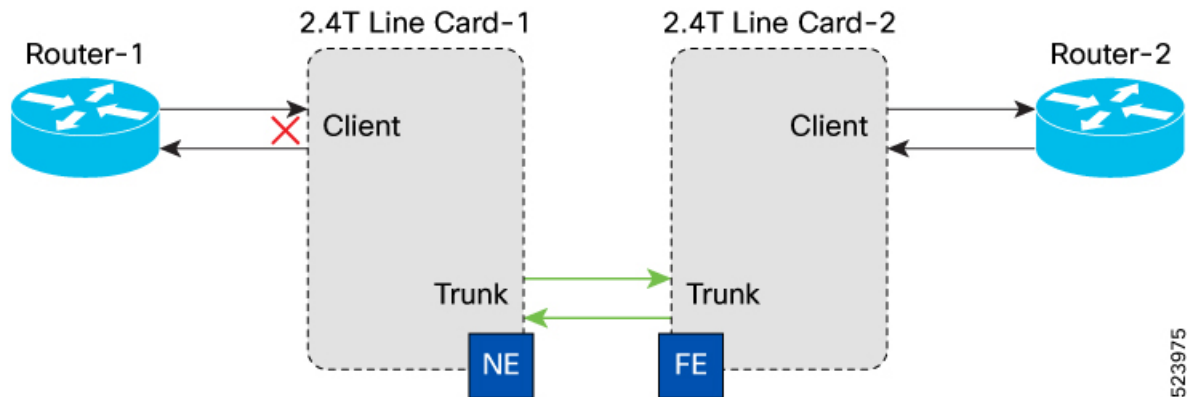

523975

These tables list the alarms that are raised at the respective ports of each node:

Table 13: Active and Suppressed Alarms for Near End (NE) Interface Faults

Node	Active Alarms	Suppressed Alarms
Router-1	No Alarms	No Alarms
NE_Client	<ul style="list-style-type: none"> • HI-SER • DEG-SER 	No Alarms
NE_Trunk	No Alarms	No Alarms

Table 14: Active and Suppressed Alarms for Far End (FE) Interface Faults

Node	Active Alarms	Suppressed Alarms
Router -2	LOCAL-DEG-SER ⁴	No Alarms
FE_Client	No Alarms	No Alarms
FE_Trunk	No Alarms	No Alarms

⁴ The capability of the router is the determining factor for LD (LOCAL-DEG-SER) reporting. According to IEEE Standard 802.3, implementing Forward Error Correction (FEC) alarms is optional. However, if these alarms are supported, the router inserts an RD (Remote-Deg-Ser) in the upstream direction in response to the LD (Local-FEC -Deg-Ser) alarm.

Client Unidirectional Degraded Symbol Error Rate

When there is a client unidirectional Degraded Symbol Error Rate (DEG-SER) between Router-1 and 2.4T Line Card-1, alarms are raised and suppressed at the respective ports of each node.

This figure displays client unidirectional DEG-SER:

Figure 8: Client Unidirectional DEG-SER

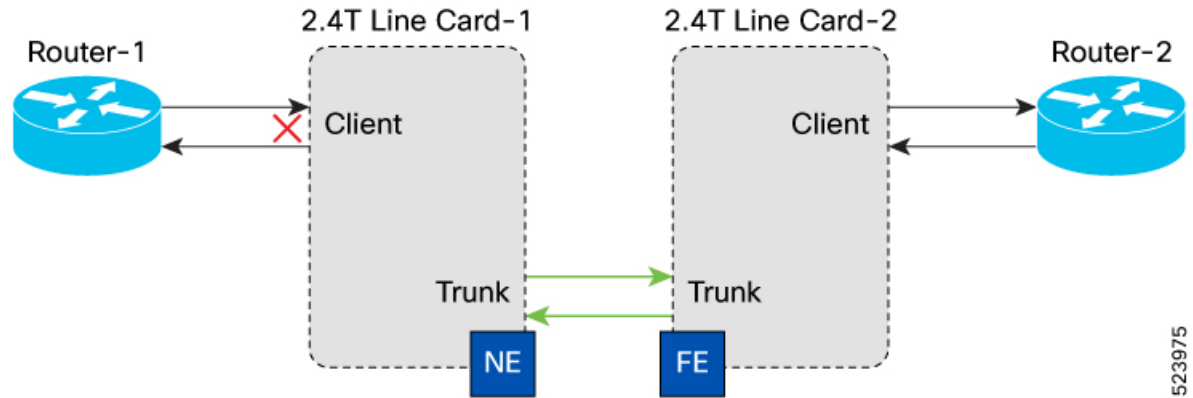

523975

These tables list the alarms that are raised at the respective ports of each node:

Table 15: Active and Suppressed Alarms for Near End (NE) Interface Faults

Node	Active Alarms	Suppressed Alarms
Router-1	No Alarms	No Alarms
NE_Client	DEG-SER Example: DEG-SER :DECLARE: FourHundredGigECtrlr0/1/0/1:	No Alarms
NE_Trunk	No Alarms	No Alarms

Table 16: Active and Suppressed Alarms for Far End (FE) Interface Faults

Node	Active Alarms	Suppressed Alarms
Router-2	LOCAL-DEG-SER ⁵	No Alarms
FE_Client	No Alarms	No Alarms
FE_Trunk	No Alarms	No Alarms

⁵ The capability of the router is the determining factor for LD (LOCAL-DEG-SER) reporting. According to IEEE Standard 802.3, implementing Forward Error Correction (FEC) alarms is optional. However, if these alarms are supported, the router inserts an RD (Remote-Deg-Ser) in the upstream direction in response to the LD (Local-FEC -Deg-Ser) alarm.

Client Unidirectional LOCAL-DEG-SER

When there is a client unidirectional LOCAL-DEG-SER (LD) between Router-1 and 2.4T Line Card-1, alarms are raised and suppressed at the respective ports of each node.

This figure displays client unidirectional LD.

Figure 9: Client Unidirectional LD

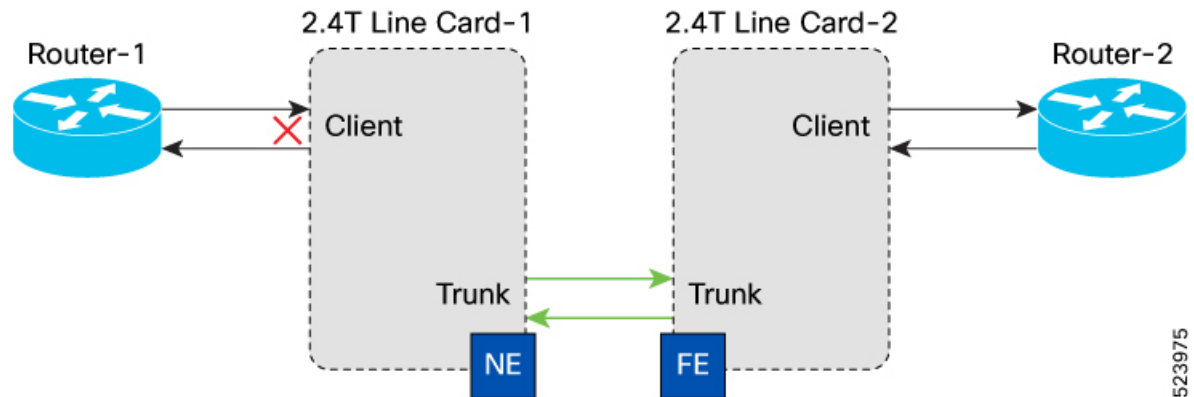

523975

These tables list the alarms that are raised at the respective ports of each node.

Table 17: Active and Suppressed Alarms for Near End (NE) Interface Faults

Node	Active Alarms	Suppressed Alarms
Router-1	No Alarms	No Alarms
NE_Client	LOCAL-DEG-SER	No Alarms
NE_Trunk	No Alarms	No Alarms

Table 18: Active and Suppressed Alarms for Far End (FE) Interface Faults

Node	Active Alarms	Suppressed Alarms
Router 2	LOCAL-DEG-SER ⁶	No Alarms
FE_Client	No Alarms	No Alarms
FE_Trunk	No Alarms	No Alarms

⁶ The capability of the router is the determining factor for LD (LOCAL-DEG-SER) reporting. According to IEEE Standard 802.3, implementing Forward Error Correction (FEC) alarms is optional. However, if these alarms are supported, the router inserts an RD (Remote-Deg-Ser) in the upstream direction in response to the LD (Local-FEC -Deg-Ser) alarm.

Client Unidirectional REMOTE-DEG-SER

When there is a client unidirectional REMOTE-DEG-SER (RD) between Router-1 and 2.4T Line Card-1, alarms are raised and suppressed at the respective ports of each node.

This figure displays client unidirectional RD.

Figure 10: Client Unidirectional RD

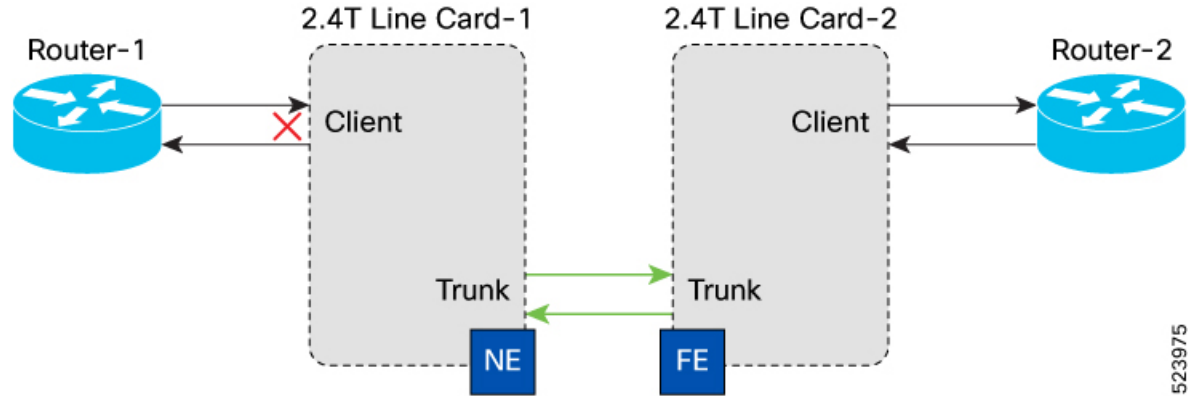

523975

These tables list the alarms that are raised at the respective ports of each node.

Table 19: Active and Suppressed Alarms for Near End (NE) Interface Faults

Node	Active Alarms	Suppressed Alarms
Router 1	LOCAL-DEG-SER ⁷	No Alarms
NE_Client	REMOTE-DEG-SER	No Alarms
NE_Trunk	No Alarms	No Alarms

⁷ The capability of the router is the determining factor for LD (LOCAL-DEG-SER) reporting. According to IEEE Standard 802.3, implementing Forward Error Correction (FEC) alarms is optional. However, if these alarms are supported, the router inserts an RD (Remote-Deg-Ser) in the upstream direction in response to the LD (Local-FEC -Deg-Ser) alarm.

Table 20: Active and Suppressed Alarms for Far End (FE) Interface Faults

Node	Active Alarms	Suppressed Alarms
Router 2	RD	No Alarms
FE_Client	No Alarms	No Alarms
FE_Trunk	No Alarms	No Alarms

Client Unidirectional Improper Removal

When there is a client unidirectional Improper Removal (IMPROPRMVL) between Router-1 and 2.4T Line Card-1, alarms are raised and suppressed at the respective ports of each node.

This figure displays client unidirectional IMPROPRMVL.

Figure 11: Client Unidirectional IMPROPRMVL

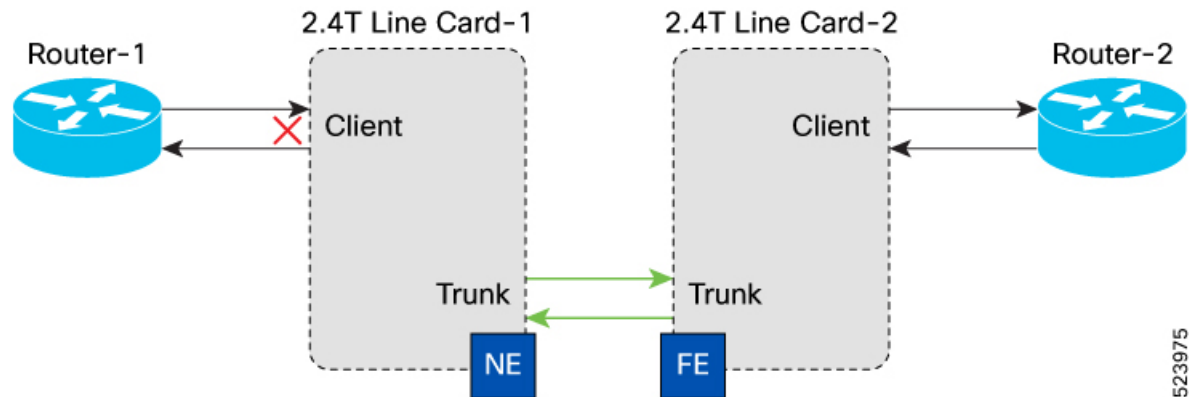

523975

These tables lists the alarms that are raised at the respective ports of each node.

Table 21: Active and Suppressed Alarms for Near End (NE) Interface Faults

Node	Active Alarms	Suppressed Alarms
Router-1	LOS	No Alarms
NE_Client	IMPROPRMVL	SYNCLOSS
NE_Trunk	No Alarms	No Alarms

Table 22: Active and Suppressed Alarms for Far End (FE) Interface Faults

Node	Active Alarms	Suppressed Alarms
Router-2	<ul style="list-style-type: none"> Local Fault LOCAL-DEG-SER⁸ 	No Alarms
FE_Client	Remote Fault	No Alarms
FE_Trunk	OPUK-CSF	No Alarms

⁸ The capability of the router is the determining factor for LD (LOCAL-DEG-SER) reporting. According to IEEE Standard 802.3, implementing Forward Error Correction (FEC) alarms is optional. However, if these alarms are supported, the router inserts an RD (Remote-Deg-Ser) in the upstream direction in response to the LD (Local-FEC -Deg-Ser) alarm.

Trunk Unidirectional Fiber Cut

When there is a trunk unidirectional fiber cut between 2.4T line card-1 and 2.4T line card-2, alarms are raised and suppressed at the respective ports of each node.

This figure displays trunk unidirectional fiber cut.

Figure 12: Trunk Unidirectional Fiber Cut

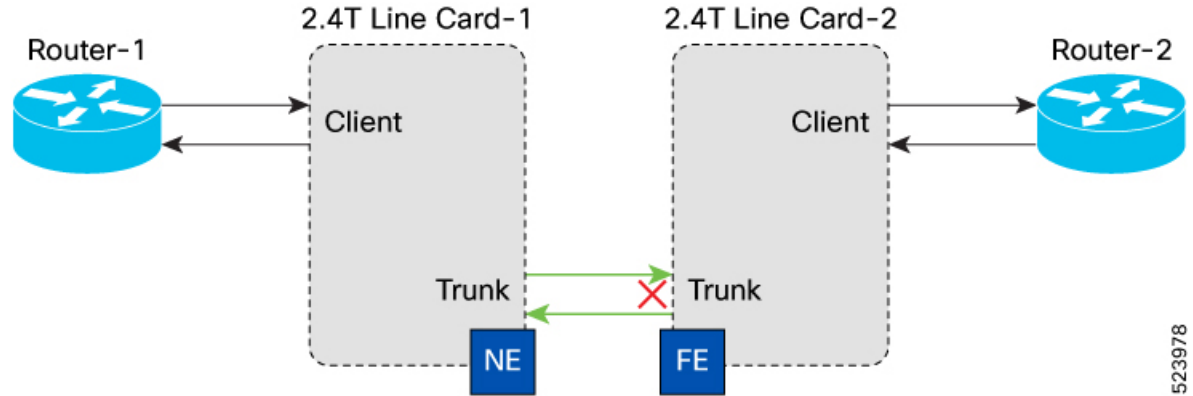

523978

These tables list the alarms that are raised at the respective ports of each node.

Table 23: Active and Suppressed Alarms for Near End (NE) Interface Faults

Node	Active Alarms	Suppressed Alarms
Router-1	Remote Fault	No Alarms
NE_Client	No Alarms	No Alarms
NE_Trunk	<ul style="list-style-type: none"> FLEXO-RDI ODUK-BDI-PM 	No Alarms

Table 24: Active and Suppressed Alarms for Far End (FE) Interface Faults

Node	Active Alarms	Suppressed Alarms
Router-2	<ul style="list-style-type: none"> Local Fault LOCAL-DEG-SER⁹ 	No Alarms
FE_Client	Remote Fault	No Alarms
FE_Trunk	LOS-P	No Alarms

⁹ The capability of the router is the determining factor for LD (LOCAL-DEG-SER) reporting. According to IEEE Standard 802.3, implementing Forward Error Correction (FEC) alarms is optional. However, if these alarms are supported, the router inserts an RD (Remote-Deg-Ser) in the upstream direction in response to the LD (Local-FEC -Deg-Ser) alarm.

Trunk Bidirectional Fiber Cut

When there is a trunk bi-directional fiber cut between 2.4T line card-1 and 2.4T line card-2 alarms are raised and suppressed at the respective ports of each node.

This figure displays trunk bidirectional fiber cut.

Figure 13: Trunk Bi-directional Fiber Cut

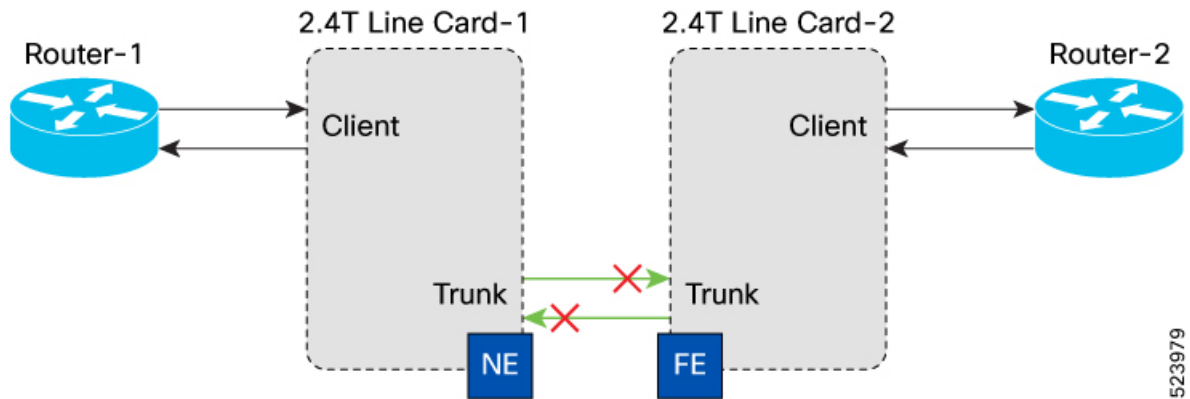

523979

These tables list the alarms that are raised at the respective ports of each node.

Table 25: Near End (NE) Interface Faults: Active and Suppressed Alarms

Node	Active Alarms	Suppressed Alarms
Router 1	<ul style="list-style-type: none"> LOCAL-DEG-SER¹⁰ Local Fault 	No Alarms
NE_Client	Remote Fault	No Alarms
NE_Trunk	LOS-P	No Alarms

¹⁰ The capability of the router is the determining factor for LD (LOCAL-DEG-SER) reporting. According to IEEE Standard 802.3, implementing Forward Error Correction (FEC) alarms is optional. However, if these alarms are supported, the router inserts an RD (Remote-Deg-Ser) in the upstream direction in response to the LD (Local-FEC -Deg-Ser) alarm.

Table 26: Active and Suppressed Alarms for Far End (FE) Interface Faults

Node	Active Alarms	Suppressed Alarms
Router 2	<ul style="list-style-type: none"> Local Fault LOCAL-DEG-SER¹¹ 	No Alarms
FE_Client	Remote Fault	No Alarms
FE_Trunk	LOS-P	No Alarms

¹¹ The capability of the router is the determining factor for LD (LOCAL-DEG-SER) reporting. According to IEEE Standard 802.3, implementing Forward Error Correction (FEC) alarms is optional. However, if these alarms are supported, the router inserts an RD (Remote-Deg-Ser) in the upstream direction in response to the LD (Local-FEC -Deg-Ser) alarm.

Trunk Frequency Mismatch - Complete Offset with 150GHz Spacing

When there is a trunk frequency mismatch between 2.4T line card-1 and 2.4T line card-2 alarms, are raised and suppressed at the respective ports of each node.

This figure displays trunk frequency mismatch for complete offset with 150GHz spacing.

Figure 14: Trunk Frequency Mismatch

These tables list the alarms that are raised at the respective ports of each node.

Table 27: Active and Suppressed Alarms for Near End (NE) Interface Faults

Node	Active Alarms	Suppressed Alarms
Router-1	<ul style="list-style-type: none"> Local Fault LOCAL-DEG-SER¹² 	No Alarms
NE_Client	Remote Fault	No Alarms
NE_Trunk	LOS-P	No Alarms

¹² The capability of the router is the determining factor for LD (LOCAL-DEG-SER) reporting. According to IEEE Standard 802.3, implementing Forward Error Correction (FEC) alarms is optional. However, if these alarms are supported, the router inserts an RD (Remote-Deg-Ser) in the upstream direction in response to the LD (Local-FEC -Deg-Ser) alarm.

Table 28: Active and Suppressed Alarms for Far End (FE) Interface Faults

Node	Active Alarms	Suppressed Alarms
Router -2	<ul style="list-style-type: none"> Local Fault LOCAL-DEG-SER¹³ 	No Alarms
FE_Client	Remote Fault	No Alarms
FE_Trunk	LOS-P	No Alarms

¹³ The capability of the router is the determining factor for LD (LOCAL-DEG-SER) reporting. According to IEEE Standard 802.3, implementing Forward Error Correction (FEC) alarms is optional. However, if these alarms are supported, the router inserts an RD (Remote-Deg-Ser) in the upstream direction in response to the LD (Local-FEC -Deg-Ser) alarm.

Trunk Frequency Mismatch - Partial Offset with 75GHz Spacing

When there is a trunk frequency mismatch between 2.4T line card-1 and 2.4T line card-2 alarms, are raised and suppressed at the respective ports of each node.

The following figure displays trunk frequency mismatch for partial offset with 75GHz spacing::

Figure 15: Trunk Frequency Mismatch

These tables list the alarms that are raised at the respective ports of each node.

Table 29: Active and Suppressed Alarms for Near End (NE) Interface Faults

NE Interface Faults		
Node	Active Alarms	Suppressed Alarms
Router-1	<ul style="list-style-type: none"> • LF • LD¹⁴ 	No Alarms
NE_Client	RF Example, RF: DECLARE :FourHundredGigEctrlr0/1/0/1	No Alarms
NE_Trunk	FLEXO-LOF & OSNR Example: FLEXO-LOF :DECLARE :CoherentDSP0/1/0/0: OSNR :DECLARE :Optics0/1/0/0	No Alarms

¹⁴ The capability of the router is the determining factor for LD (LOCAL-DEG-SER) reporting. According to IEEE Standard 802.3, implementing Forward Error Correction (FEC) alarms is optional. However, if these alarms are supported, the router inserts an RD (Remote-Deg-Ser) in the upstream direction in response to the LD (Local-FEC -Deg-Ser) alarm.

Table 30: Active and Suppressed Alarms for Far End (FE) Interface Faults

FE Interface Faults		
Node	Active Alarms	Suppressed Alarms
Router -2	<ul style="list-style-type: none"> • LF • LD¹⁵ 	No Alarms
FE_Client	RF Example, RF: DECLARE : FourHundredGigEctrlr0/1/0/1	No Alarms
FE_Trunk	FLEXO-LOF & OSNR Example: FLEXO-LOF :DECLARE : CoherentDSP0/1/0/0: OSNR :DECLARE :Optics0/1/0/0	No Alarms

- ¹⁵ The capability of the router is the determining factor for LD (LOCAL-DEG-SER) reporting. According to IEEE Standard 802.3, implementing Forward Error Correction (FEC) alarms is optional. However, if these alarms are supported, the router inserts an RD (Remote-Deg-Ser) in the upstream direction in response to the LD (Local-FEC -Deg-Ser) alarm.

Trunk Unidirectional Loss of Frame

When there is a trunk unidirectional Loss of Frame (LOF) between 2.4T line card-1 and 2.4T line card-2, alarms are raised and suppressed at the respective ports of each node.

This figure displays trunk LOF.

Figure 16: Trunk Unidirectional LOF

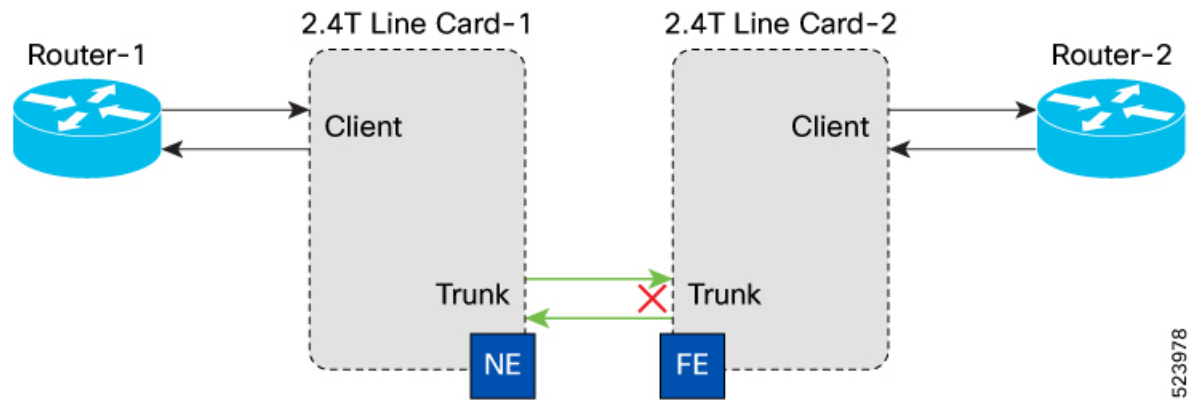

523978

These tables list the alarms that are raised at the respective ports of each node.

Table 31: Active and Suppressed Alarms for Near End (NE) Interface Faults

Node	Active Alarms	Suppressed Alarms
Router-1	RF	No Alarms
NE_Client	No Alarms	No Alarms
NE_Trunk	<ul style="list-style-type: none"> FLEXO-RDI Example: FLEXO-RDI :DECLARE :CoherentDSP0/1/0/0: ODUK-BDI-PM Example: ODUK-BDI-PM :DECLARE :ODU-FLEX0/1/0/0/1: 	No Alarms

Table 32: Active and Suppressed Alarms for Far End (FE) Interface Faults

Node	Active Alarms	Suppressed Alarms
------	---------------	-------------------

Router -2	<ul style="list-style-type: none"> • LF • LD¹⁶ 	No Alarms
FE_Client	RF Example, RF: DECLARE :FourHundredGigEctrlr0/1/0/1	No Alarms
FE_Trunk	<ul style="list-style-type: none"> • FLEXO-LOF Example: FLEXO-LOF :DECLARE :CoherentDSP0/1/0/0: <ul style="list-style-type: none"> • OSNR Example: OSNR:DECLARE :Optics0/1/0/0:	No Alarms

¹⁶ The capability of the router is the determining factor for LD (LOCAL-DEG-SER) reporting. According to IEEE Standard 802.3, implementing Forward Error Correction (FEC) alarms is optional. However, if these alarms are supported, the router inserts an RD (Remote-Deg-Ser) in the upstream direction in response to the LD (Local-FEC -Deg-Ser) alarm.

Trunk Group ID Mismatch

When there is a trunk Group ID Mismatch (GIDM) between 2.4T line card-1 and 2.4T line card-2, alarms are raised and suppressed at the respective ports of each node.

The following figure displays trunk GIDM:

Figure 17: Trunk GIDM

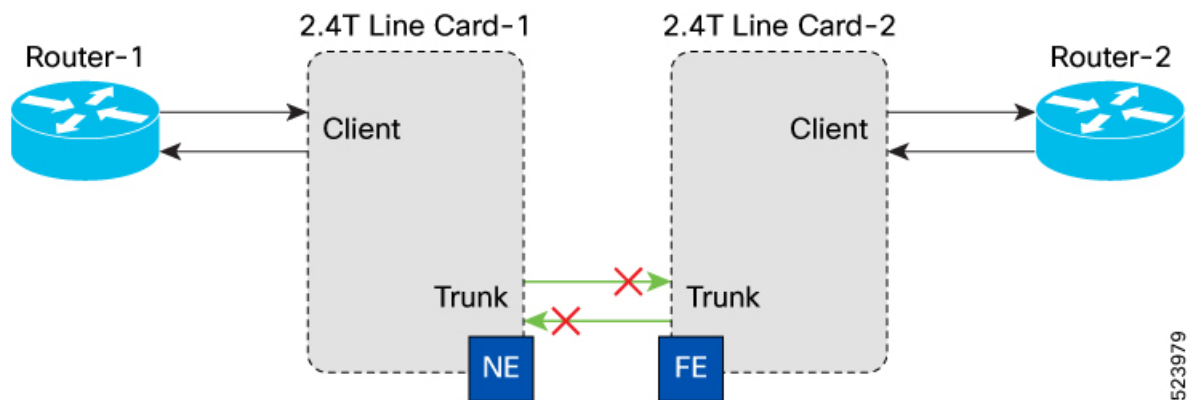

The following tables list the alarms that are raised at the respective ports of each node:

Table 33: Active and Suppressed Alarms for Near End (NE) Interface Faults

Node	Active Alarms	Suppressed Alarms
------	---------------	-------------------

Router-1	<ul style="list-style-type: none"> • LD • LF 	No Alarms
NE_Client	RF Example: RF :DECLARE :FourHundredGigEctr0/1/0/1	No Alarms
NE_Trunk	Flexo-GIDM Example: Flexo-GIDM :DECLARE :CoherentDSP0/1/0/0:	No Alarms

Table 34: Active and Suppressed Alarms for Far End (FE) Interface Faults

Node	Active Alarms	Suppressed Alarms
Router-2	<ul style="list-style-type: none"> • LF • LD¹⁷ 	No Alarms
FE_Client	RF Example, RF: DECLARE :FourHundredGigEctr0/1/0/1	No Alarms
FE_Trunk	FLEXO-GIDM Example: FLEXO-GIDM :DECLARE :CoherentDSP0/1/0/0:	No Alarms

¹⁷ The capability of the router is the determining factor for LD (LOCAL-DEG-SER) reporting. According to IEEE Standard 802.3, implementing Forward Error Correction (FEC) alarms is optional. However, if these alarms are supported, the router inserts an RD (Remote-Deg-Ser) in the upstream direction in response to the LD (Local-FEC -Deg-Ser) alarm.

Trunk Unidirectional OTUK-TIM

When there is a trunk unidirectional OTUK-TIM between 2.4T line card-1 and 2.4T line card-2, alarms are raised and suppressed at the respective ports of each node.

This figure displays trunk unidirectional OTUK-TIM.

Figure 18: Trunk Unidirectional OTUK-TIM

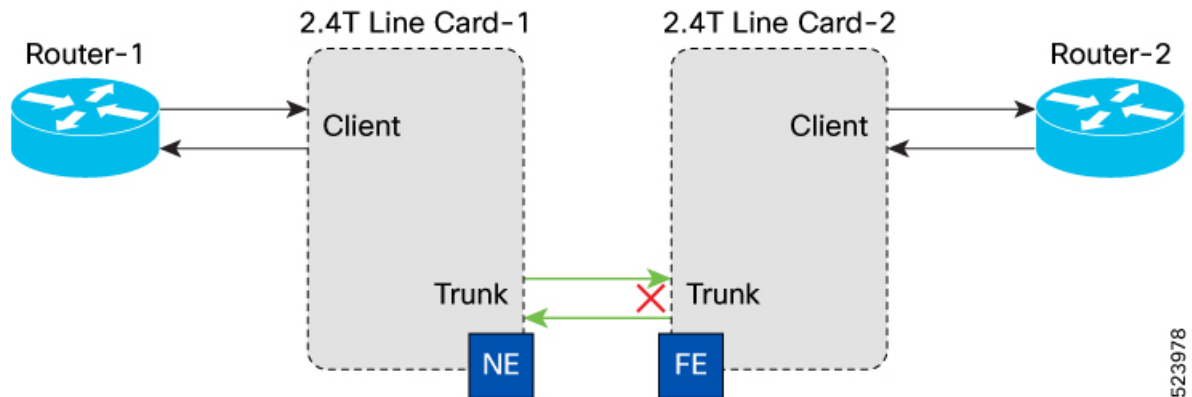

523978

These tables list the alarms that are raised at the respective ports of each node.

Table 35: Active and Suppressed Alarms for Near End (NE) Interface Faults

Node	Active Alarms	Suppressed Alarms
Router -1	No Alarms	No Alarms
NE_Client	No Alarms	No Alarms
NE_Trunk	No Alarms	No Alarms

Table 36: Active and Suppressed Alarms for Far End (FE) Interface Faults

Node	Active Alarms	Suppressed Alarms
Router-2	No Alarms	No Alarms
FE_Client	No Alarms	No Alarms
FE_Trunk	OTUK-TIM Example: OTUK-TIM :DECLARE :CoherentDSP0/1/0/0:	No Alarms

Trunk Unidirectional Improper Removal

When there is a trunk optics Improper Removal (IMPROPRMVL) between 2.4T line card-1 and 2.4T line card-2, alarms are raised and suppressed at the respective ports of each node.

This figure displays trunk optics IMPROPRMVL.

Figure 19: Trunk Unidirectional IMPROPRMVL

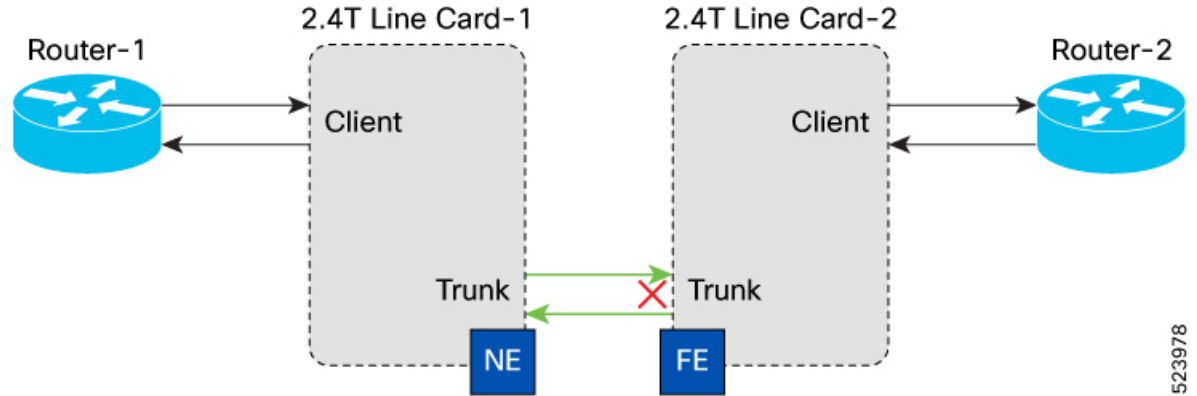

523978

These tables list the alarms that are raised at the respective ports of each node.

Table 37: Active and Suppressed Alarms for Near End (NE) Interface Faults

Node	Active Alarms	Suppressed Alarms
Router-1	<ul style="list-style-type: none"> • LF • LD¹⁸ 	No Alarms
NE_Client	RF Example: RF :DECLARE :FourHundredGigEctr0/1/0/1	No Alarms
NE_Trunk	LOS-P	No Alarms

¹⁸ The capability of the router is the determining factor for LD (LOCAL-DEG-SER) reporting. According to IEEE Standard 802.3, implementing Forward Error Correction (FEC) alarms is optional. However, if these alarms are supported, the router inserts an RD (Remote-Deg-Ser) in the upstream direction in response to the LD (Local-FEC -Deg-Ser) alarm.

Table 38: Far End (FE) Interface Faults: Active and Suppressed Alarms

Node	Active Alarms	Suppressed Alarms
Router-2	<ul style="list-style-type: none"> • LF • LD¹⁹ 	No Alarms
FE_Client	RF Example: RF :DECLARE :FourHundredGigEctr0/1/0/1	No Alarms

FE_Trunk	IMPROPRMVL Example: IMPROPRMVL :DECLARE :Optics0/1/0/1:	No Alarms
----------	--	-----------

- ¹⁹ The capability of the router is the determining factor for LD (LOCAL-DEG-SER) reporting. According to IEEE Standard 802.3, implementing Forward Error Correction (FEC) alarms is optional. However, if these alarms are supported, the router inserts an RD (Remote-Deg-Ser) in the upstream direction in response to the LD (Local-FEC -Deg-Ser) alarm.