



Install the Cisco NCS 1020 Chassis

This chapter contains procedures to install the Cisco NCS 1020 chassis.

- [Rack Compatibility](#), on page 1
- [Attach the Mounting Brackets to the Chassis](#), on page 2
- [Install the Cisco NCS 1020 Chassis on an EIA/ANSI/ETSI Rack](#), on page 4
- [General Power and Grounding Requirements](#), on page 12

Rack Compatibility

The Cisco NCS 1020 chassis can be installed in a standard EIA (19"), ANSI (23"), or ETSI rack.

- The rack can be two post type or four post type rack.
- The 19" and 23" racks must be compliant with "EIA Universal" holes.
- The ETSI Rack must be compliant with "ETSI Universal" holes.

Figure 1: Rack Specification

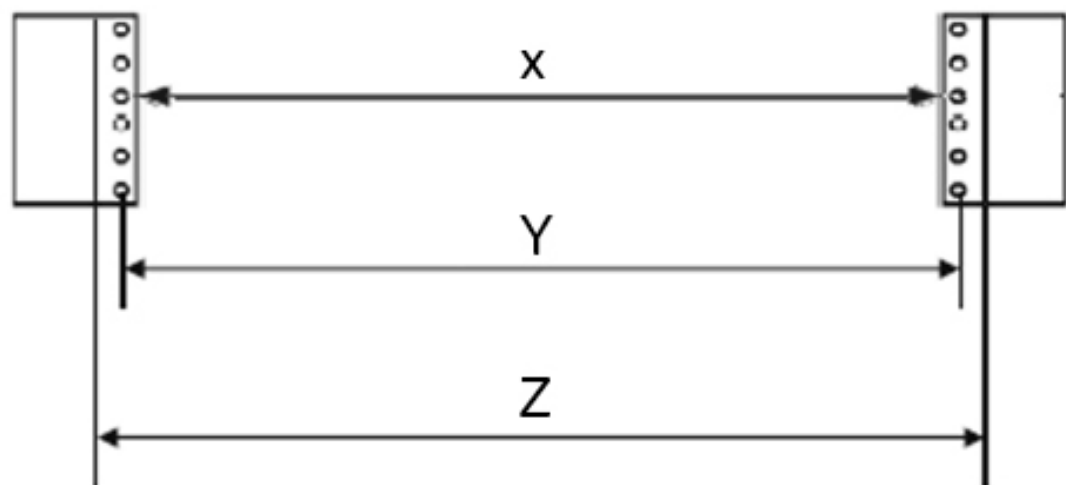

368967

Rack Type	Rack Front Opening X	Rack Mounting Hole Center-Center Y	Mounting Flange Dimension Z
19" racks	450.8mm (17.75")	465mm (18.312")	482.6mm (19")
23" racks	552.45mm (21.75")	566.7mm (22.312")	584.2mm (23")
ETSI racks	500.0mm(19.68")	515.0mm(20.276")	533.4mm(21")

Attach the Mounting Brackets to the Chassis

Use this procedure to attach the mounting brackets to the Cisco NCS 1020 chassis.

Before you begin

Required tools and equipment:

- NCS1020-19-KIT= accessory kit
- Torx head screwdriver (Cisco supplied)

-
- Step 1** Identify the left and right brackets.
- Step 2** Place the wider side of the mounting bracket flush against the chassis markings on the sides.
- Step 3** Align the mounting bracket screw holes against the chassis screw holes.

Figure 2: Attaching the Mounting Brackets on a Loaded Chassis

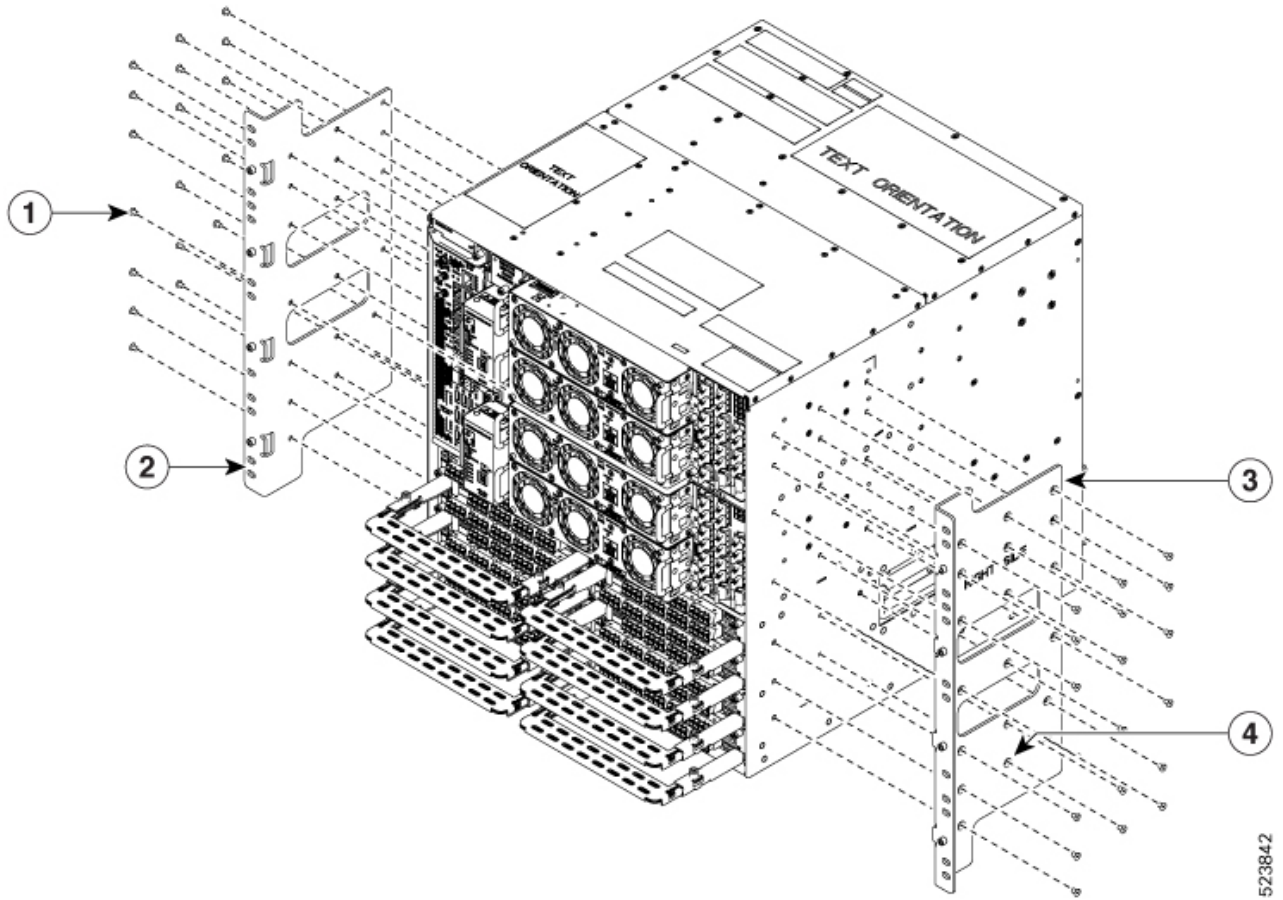

523842

Figure 3: Attaching the Mounting Brackets on an Empty Chassis

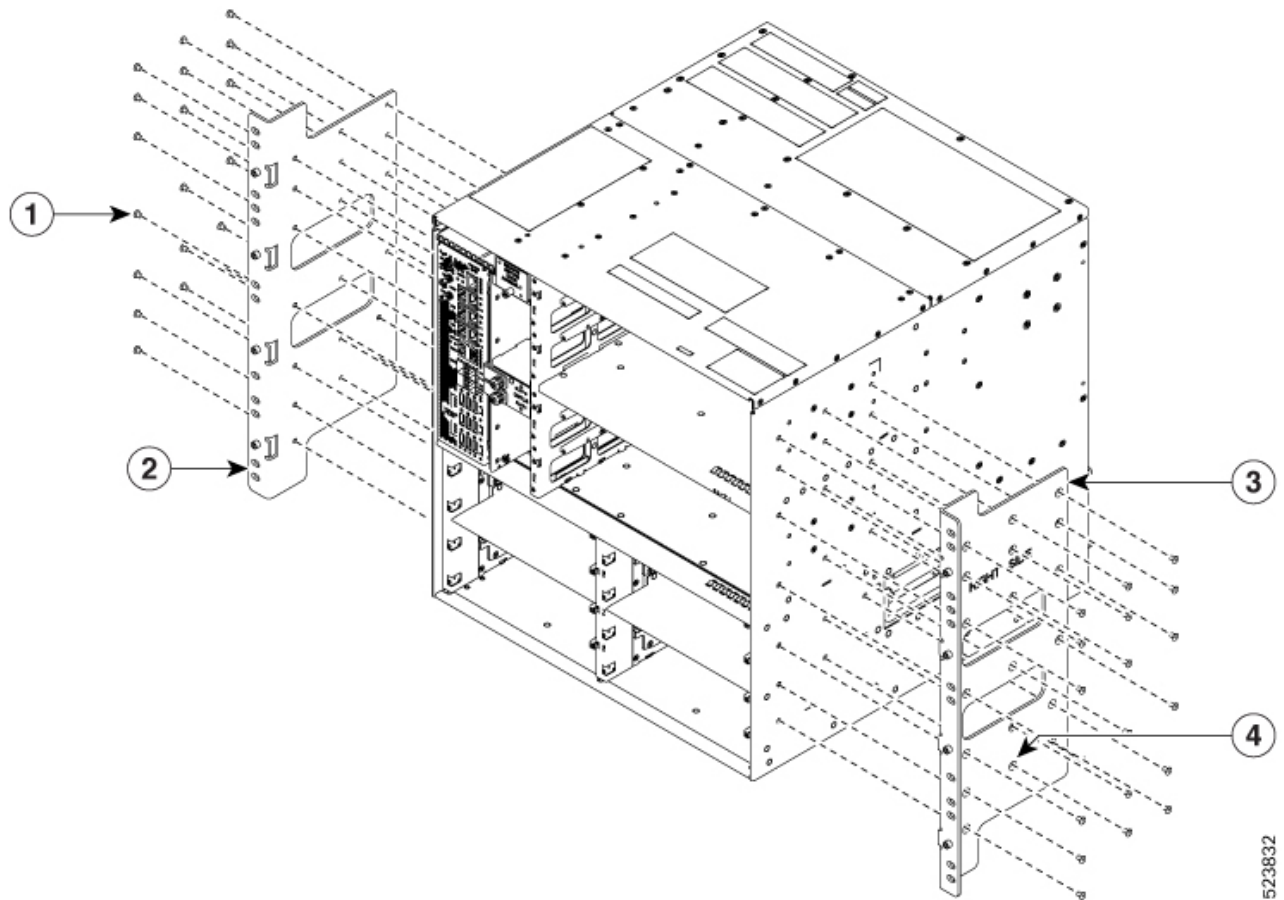

1	M4 flat torx head screws	3	Right bracket
2	Left bracket	4	Bracket screw holes

Step 4 Insert the M4 flat head screws available in the accessory kit (NCS1020-19-KIT=) and tighten them to a torque value of 1.5 N-m (13.3 lbs-in).

Step 5 Repeat the preceding steps to mount the bracket on the opposite side.

What to do next

[Install the Cisco NCS 1020 Chassis on an EIA/ANSI/ETSI Rack, on page 4](#)

Install the Cisco NCS 1020 Chassis on an EIA/ANSI/ETSI Rack

Use this procedure to mount the Cisco NCS 1020 chassis on an EIA/ANSI/ETSI rack.



Note The mounting brackets and adapters fit only in the front posts of the four-post rack. Therefore, you can use the mounting brackets and adapters for both two-post and four-post racks.



Warning **Rack Mount Instructions**

The following or similar rack-mount instructions are included with the installation instructions:

- **Elevated Operating Ambient**—If installed in a closed or multirack assembly, the operating temperature of the rack environment may be greater than room temperature. Therefore, consideration should be given to installing the equipment in an environment compatible with the maximum ambient temperature (T_{ma}) specified.
 - **Reduced Air Flow**—Installation of the equipment in a rack should be such that the amount of air flow required for safe operation of the equipment is not compromised.
 - **Mechanical Loading**—Mounting of the equipment in the rack should be such that a hazardous condition is not achieved due to uneven mechanical loading.
 - **Circuit Overloading**—Consideration should be given to the connection of the equipment to the supply circuit and the effect that overloading of the circuits might have on overcurrent protection and supply wiring. Appropriate consideration of equipment nameplate ratings should be used when addressing this concern.
 - **Reliable Earthing**—Reliable earthing of rack-mounted equipment should be maintained. Particular attention should be given to supply connections other than direct connections to the branch circuit (for example, use of power strips).
-

Before you begin

Ensure that the rack is compatible. See [Rack Compatibility](#).

[Attach the Mounting Brackets to the Chassis, on page 2](#)

Step 1 Attach the rack adapters to the chassis. Perform one of the following steps.

- For the 19" rack, the chassis directly fits the rack.
- For the 21" rack, use the 19 to ETSI adapter from the accessory kit (NCS1020-ETSI-KIT=). For the 23" rack, use the 19" to 23" adapter from the accessory kit (NCS1020-23-KIT=). To attach the 19" to ETSI or 19" to 23" adapter:
 - a. Identify the left side and right side adapters.
 - b. Place the adapters behind the narrower side of the mounting brackets.
 - c. Align the adapter screw holes against the mounting bracket screw holes.
 - d. Insert the adapter screws from the front on either side of the chassis.
 - e. Tighten the adapter screws to a torque value of 4.65 N-m (41 lbs-in).

Step 2 Mount the NCS 1020 chassis onto the rack. Perform the following steps:

- a. Lift the chassis to the needed position in the rack.

The fully loaded chassis requires two people to lift. Alternatively, you can use a mechanical lift to position the chassis in the rack.

- b. Align the mounting bracket screw holes against the rack screw holes.

For ETSI and 23" racks, align the adapter screw holes against the rack screw holes.

Figure 4: Mounting the NCS 1020 on a Two-Post 19" Rack

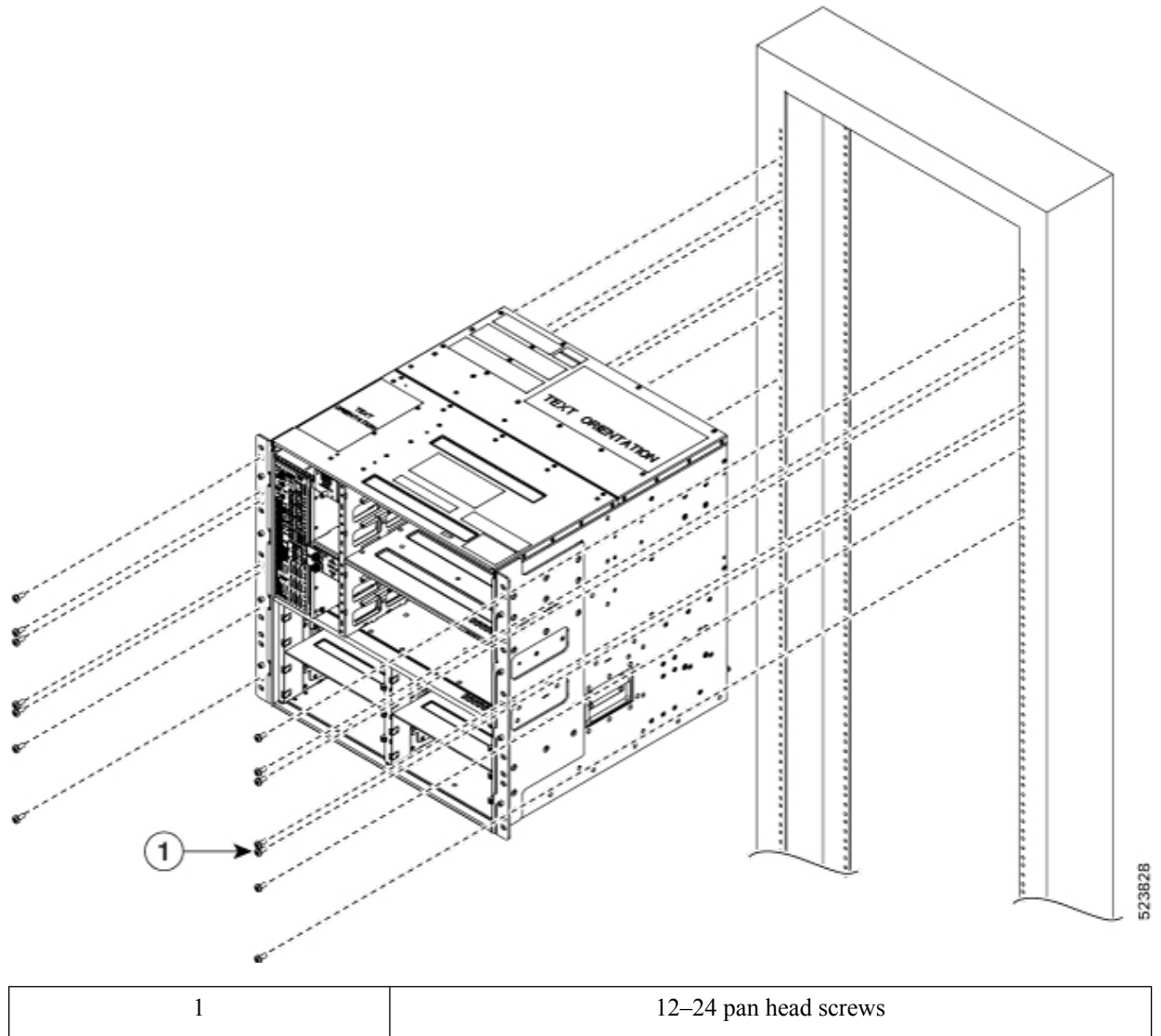
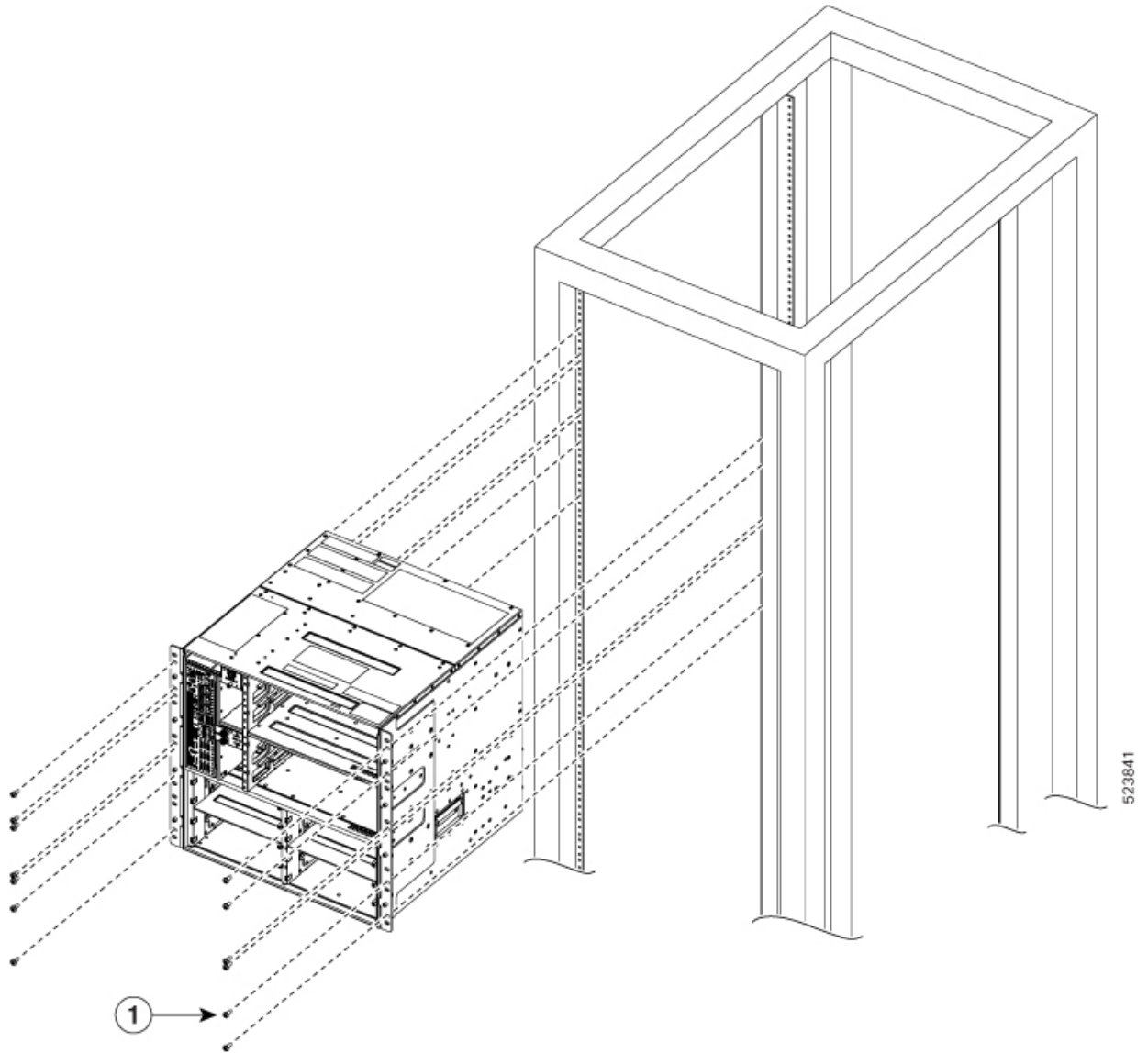

Figure 5: Mounting the NCS 1020 on a Four-Post 19" Rack



1	12-24 pan head screws
---	-----------------------

Figure 6: Mounting the NCS 1020 on a Two-Post ETSI Rack

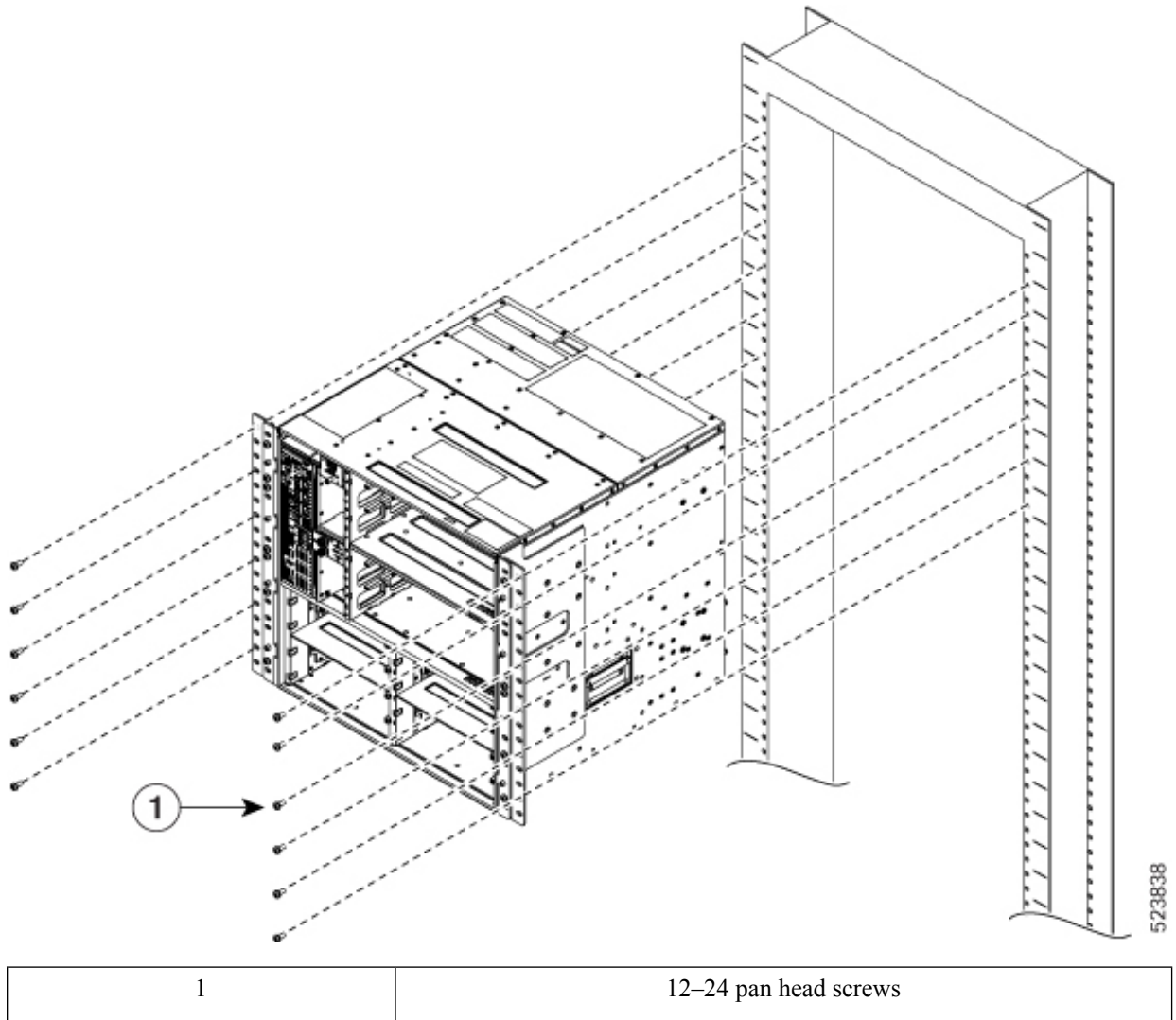
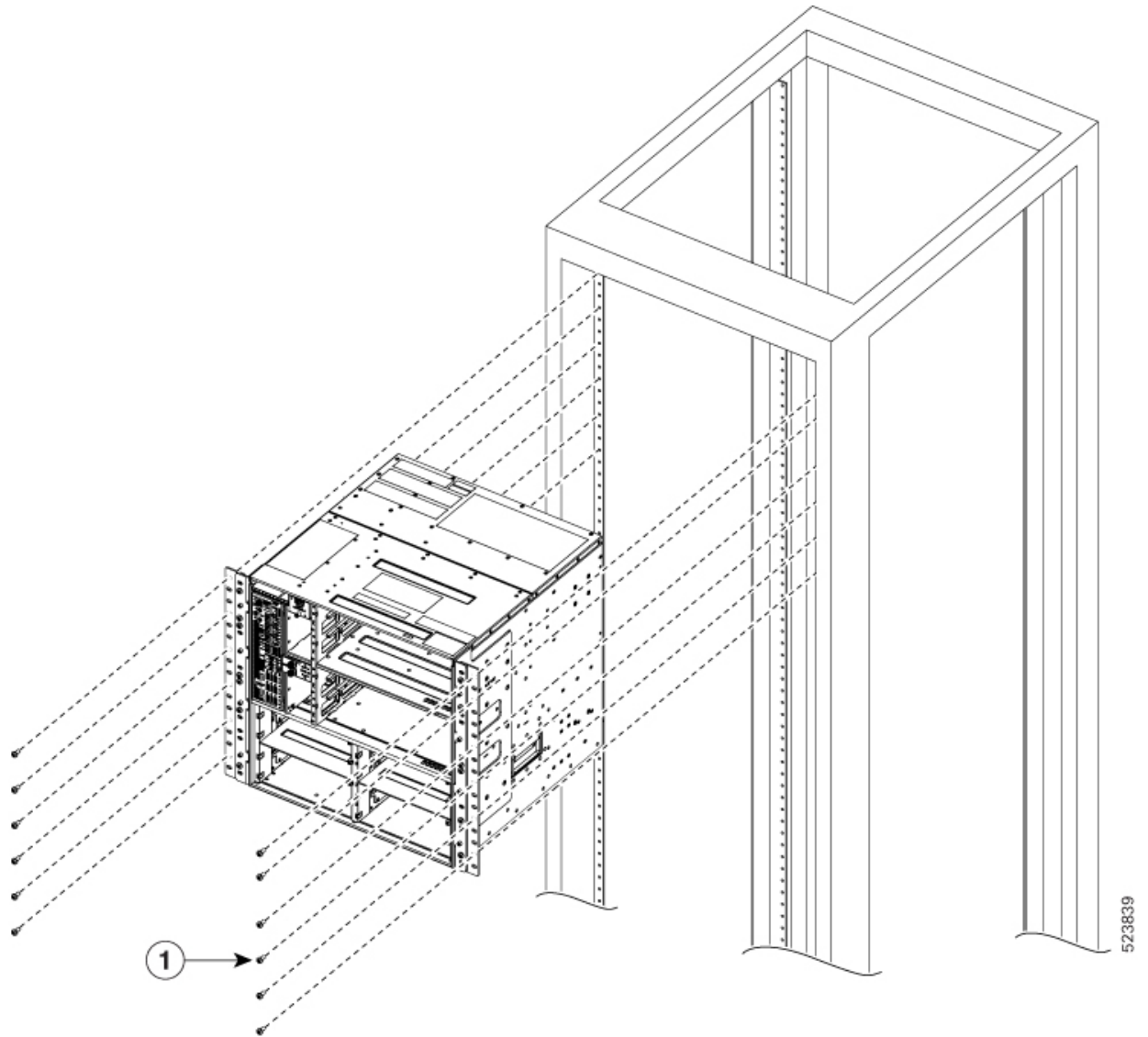
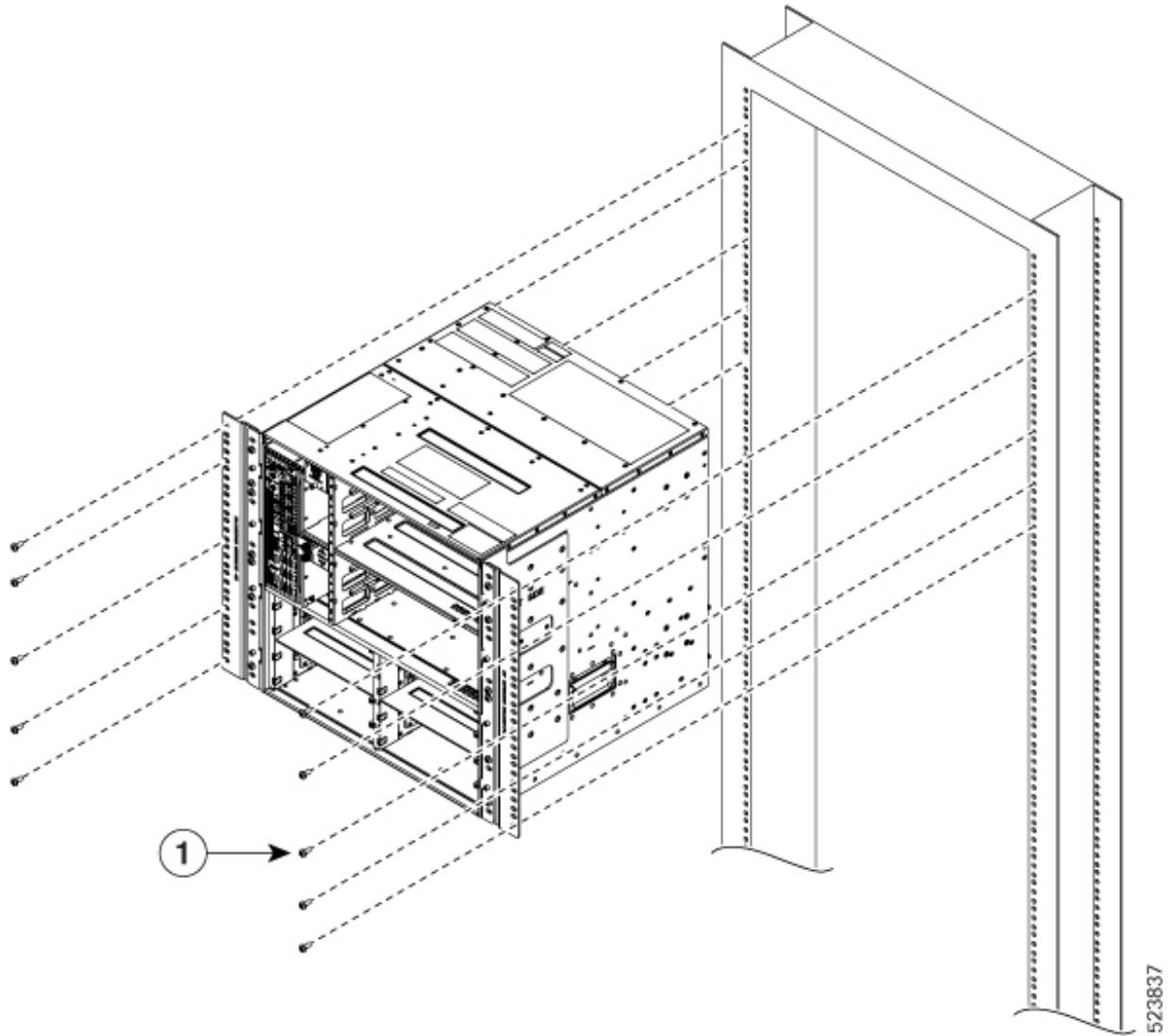

Figure 7: Mounting the NCS 1020 on a Four-Post ETSI Rack



1	12-24 pan head screws
---	-----------------------

Figure 8: Mounting the NCS 1020 on a Two-Post ANSI Rack



1	12-24 pan head screws
---	-----------------------

Figure 9: Mounting the NCS 1020 on a Four-Post ANSI Rack

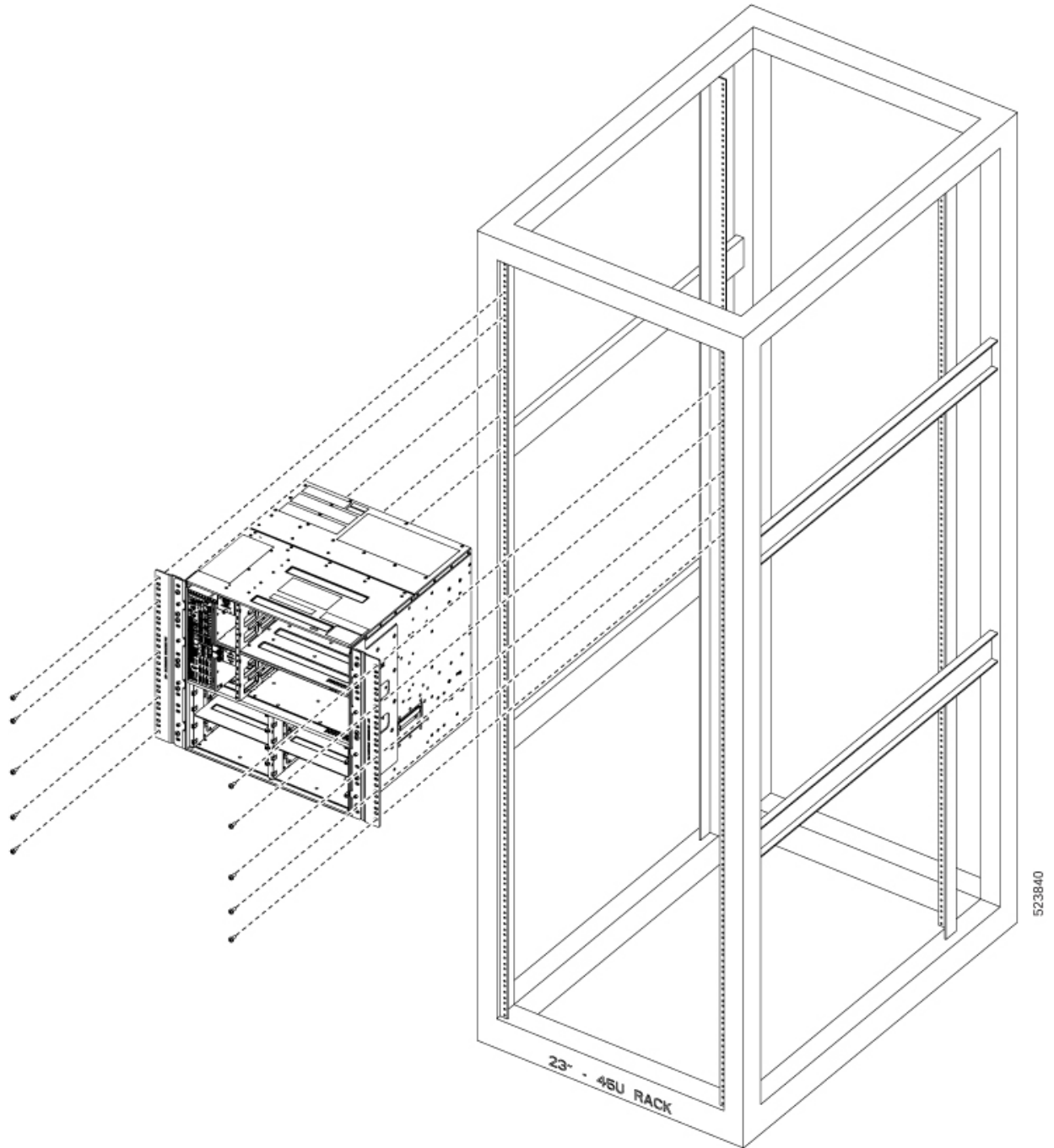

1	12-24 pan head screws
---	-----------------------

- c. Insert the mounting screws on each bracket or adapter screw holes.

- d. Using a screwdriver, tighten the 12–24 pan head screws to a torque value of 1.5 N-m (13.3 lbs-in).

General Power and Grounding Requirements

General power and grounding requirements are:

- Installation of the routing system must follow national and local electrical codes:
 - In the United States: United States National Fire Protection Association (NFPA) 70 and United States National Electrical Code (NEC).
 - In Canada: Canadian Electrical Code, part I, CSA C22.1.
 - In other countries: International Electrotechnical Commission (IEC) 60364, parts 1 through 7.
- Two separate and independent AC or DC power sources are needed to provide 2N redundancy for system power. Each power source requires its own circuit breaker.
- Each power source must provide clean power to the site. If necessary, install a power conditioner.
- The site must provide short-circuit (over-current) protection for devices.
- Proper grounding is required at the site to ensure that equipment is not damaged by lightning and power surges.



Note Ground lug connection is mandatory for the AC chassis version too.

- Site power planning must include the power requirements for any external terminals and test equipment you will use with your system.



Note Be sure to review the safety warnings in the Cisco Network Convergence System *Regulatory Compliance and Safety Information for the Cisco Network Convergence System 1020* before attempting to install the chassis.

Ground NCS 1020

This procedure provides the grounding details for the NCS 1020 chassis. In the installation of the chassis, the ground lug should be connected first.

There is one grounding point at the rear side of the NCS 1020 chassis. The following warning is affixed as a label on the chassis.



Warning High leakage current, earth connection essential before connecting supply.

**Caution**

When terminating the frame ground, do not use soldering lug connectors, screwless (push-in) connectors, quick connect connectors, or other friction-fit connectors.

-
- Step 1** Verify that the office ground cable is connected to the top of the rack and the office ground, according to local site practice.
- Step 2** Remove any paint and other nonconductive coatings from the surfaces between the shelf ground and bay frame ground point. Clean the mating surfaces and apply the appropriate antioxidant compound to the bare conductors.
- Step 3** Attach one end of the shelf ground cable (#6 AWG cable) to the ground point using the dual-hole lug connector.

Figure 10: NCS 1020 Ground Lug

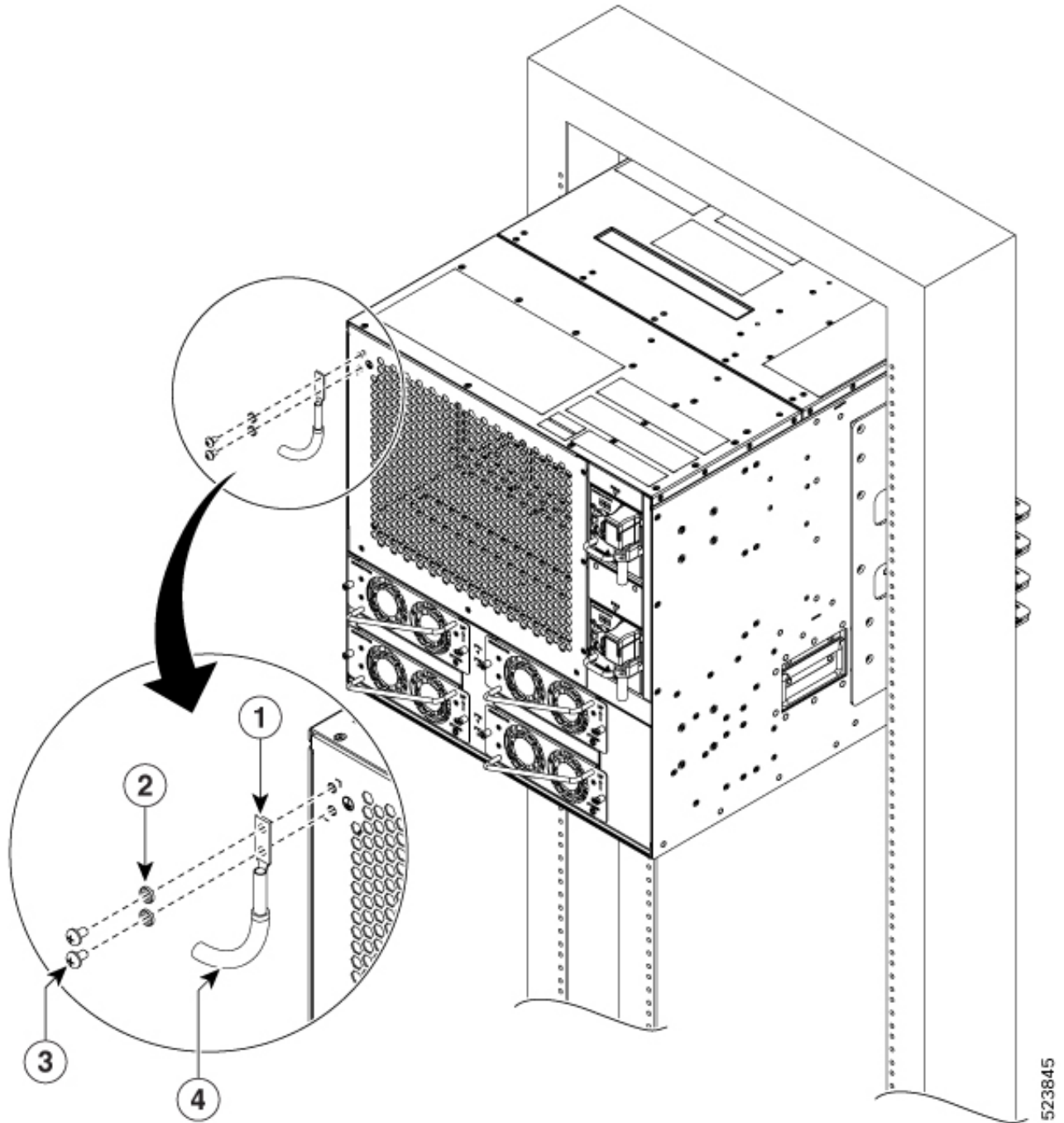

1	Double-hole lug	3	M5 pan head screws
2	M6 lock washers	4	Ground cable

The orientation of the lug cable is always at the bottom side.

Step 4 Tighten the M5 pan head screws to a torque value of 3.1 N-m (27.4 lbs-in).

- Step 5** Attach the other end of the shelf ground cable to the bay frame using a dual-hole lug connector according to the equipment rack frame specifications.
-

