



Upgrading and Managing Cisco IOS XR Software

Cisco IOS XR software is divided into software packages so that you can select which features run on your router. This module describes the concepts and tasks necessary to add feature packages, upgrade the active set of packages, roll back to a previously active set of packages, and perform other related package management tasks.

For complete descriptions of the commands listed in this module, see [Related Documents, on page 58](#). To locate documentation for other commands that might appear in the course of performing a configuration task, search online in *Cisco IOS XR Commands Master List for the Cisco CRS Router*.

Table 1: Feature History for Upgrading and Managing Cisco IOS XR Software

| Release | Modification |
|---------------|--|
| Release 3.4.0 | Support was added for installation operations in SDR EXEC mode. Three new software PIEs were added: <ul style="list-style-type: none">• Field-programmable devices (FPD)• Documentation• IPSec Module was moved to <i>System Management Configuration Guide for Cisco CRS Routers</i> from <i>Cisco IOS XR Getting Started Guide for the Cisco CRS Router</i> . |
| Release 3.6.0 | Support was added for installing PIE files from tar files. Support was added for labels to identify rollback points. |

| Release | Modification |
|---------------|---|
| Release 3.7.0 | <p>Support was added for activating software packages by specifying the operation ID of the install add command operation that added the packages.</p> <p>Simultaneous activation of multiple SMUs was streamlined to minimize disruption, with fewer cases requiring reloads.</p> <p>The install verify packages command was enhanced so that it checks for corruptions of installation state files and MBI image files as well as software files.</p> <p>Support was added for the following commands:</p> <ul style="list-style-type: none"> • install boot-options • clear boot-options • show boot-options |
| Release 3.8.0 | <p>Support was added for the pause sw-change keywords in the following commands:</p> <ul style="list-style-type: none"> • install activate • install add • install deactivate • install rollback |
| Release 4.0.0 | <p>A procedure to upgrade software from Cisco IOS XR Release 3.x was introduced. See Upgrading to Cisco IOS XR Software Release 4.0, on page 42.</p> <p>Support for installation commands was removed from EXEC mode.</p> <p>The ability to install software on a specific SDR was removed.</p> |

This module contains the following topics:

- [Overview of Cisco IOS XR Software Packages, on page 2](#)
- [Information About Package Management, on page 7](#)
- [Package Management Procedures, on page 19](#)
- [Rolling Back to a Previous Software Set, on page 55](#)
- [Additional References, on page 58](#)

Overview of Cisco IOS XR Software Packages

Cisco IOS XR software is divided into software packages so that you can select which features run on your router. Each package contains the components to perform a specific set of router functions, such as routing, security, or modular services card (MSC) support. Bundles are groups of packages that can be downloaded as a set. For example, Cisco IOS XR Unicast Routing Core Bundle (known as *mini*) provides the main packages for use on every router.

Adding a package to the router does not affect the operation of the router—it only copies the package files to a local storage device on the router, known as the *boot device* (such as the internal flash disk0:). To make the package functional on the router, you must activate it for one or more cards.

To upgrade a package, you activate a newer version of the package. When the automatic compatibility checks have been passed, the new version is activated, and the old version is deactivated.



Note Activating a software maintenance upgrade (SMU) does not cause any earlier SMUs or the package to which the SMU applies to be automatically deactivated.



Note If an interface on a router does not have a configuration and is brought up by performing no-shut operation, then upon router reload, the interface state changes to **admin-shutdown** automatically.

To downgrade a package, you activate an older version of the package. When the automatic compatibility checks have been passed, the older version is activated, and the newer version is deactivated.



Caution Do not perform any install operations when the router is reloading.



Note For more information on the features and components included in each package, refer to the release notes.

Package Installation Envelopes

Package Installation Envelopes (PIEs) are nonbootable files that contain a single package or a set of packages (called a *composite package* or *bundle*). Because the files are nonbootable, they are used to add software package files to a running router.

PIE files have a `pie` extension. When a PIE file contains software for a specific bug fix, it is called a *software maintenance upgrade* (SMU).



Note Files with the `vm` extension are bootable installation files used only to replace all current Cisco IOS XR software. These files are installed from ROM Monitor mode, which causes significant router downtime. Cisco Systems recommends installing or upgrading software packages only using PIE files as described in this document. For more information on `vm` files, see *ROM Monitor Configuration Guide for Cisco CRS Routers*.

Summary of Cisco IOS XR Software Packages

Every router includes a basic set of required packages contained in the Cisco IOS XR Unicast Routing Core Bundle. Additional optional packages can be added and activated on the router to provide specific features.

Packages in the Cisco IOS XR Unicast Routing Core Bundle

The packages contained in the Cisco IOS XR Unicast Routing Core Bundle are as follows:

- Operating system (OS) and minimum boot image (MBI)—Kernel, file system, memory management, and other slow changing core components.
- Base—Interface manager, system database, checkpoint services, configuration management, other slow-changing components.
- Infra—Resource management: rack, fabric, secure domain router (SDR).
- Routing—RIB, BGP, ISIS, OSPF, EIGRP, RIP, RPL, and other routing protocols.
- Forwarding—FIB, ARP, QoS, ACL, and other components.
- LC—MSC drivers.

The filename for this bundle is: `hfr-mini.pie-version`.

Refer to the release notes for additional information on the specific features provided by each package.

Software Maintenance Upgrades

A software maintenance upgrade (SMU) is a PIE file that contains fixes for a specific defect. A composite SMU is a PIE file that contains SMUs for more than one package. SMUs are added and activated using the same procedures as other PIE files. SMUs are created to respond to immediate issues and do not include new features. Typically, SMUs do not have a large impact on router operations. SMU versions are synchronized to the package major, minor, and maintenance versions they upgrade.

The affect of an SMU depends on its type:

- Process Restart SMU—Causes a process or group of processes to restart on activation.
- Reload SMU—Causes a parallel reload (of RPs and line cards).

SMUs are not an alternative to maintenance releases. They provide quick resolution of immediate issues. All bugs fixed by SMUs are integrated into the maintenance releases. For information on available SMUs, contact Cisco Technical Support, as described in *Obtaining Technical Assistance* in the monthly [What's New in Cisco Product Documentation](#).



Note Activating a software maintenance upgrade (SMU) does not cause any earlier SMUs, or the package to which the SMU applies, to be automatically deactivated.

Related Topics

[Updating Software Images Without a Router Reload](#)

PIE Filenames and Version Numbers

PIE filenames have two formats: one for composite-package PIEs (bundles) and one for single-package PIEs. A *composite-package file* is a PIE file that contains multiple packages.



Note Hyphens in the filename are part of the filename.

[Table 2: PIE Filenames, on page 5](#) shows the filenames for available PIE types.

Table 2: PIE Filenames

| Software Delivery Type | Filename | Example |
|------------------------|---|------------------------------|
| Composite (Bundle) PIE | <i>comp-platform-composite_name.pie-major.minor.maintenance</i> | comp-hfr-mini.pie-3.7.0 |
| Single package PIE | <i>platform-package_type-p.pie-major.minor.maintenance</i> | hfr-mgbl-p.pie-3.7.0 |
| Composite SMU | <i>comp-platform-composite_name.ddts.pie</i> | comp-hfr-001.CSCec98xxx.pie |
| Single package SMU | <i>platform-package_type-major.minor.maintenance.ddts.pie</i> | hfr-base-3.7.0.CSCei4xxx.pie |
| Note | A SMU composite name usually is “001”, which means the SMU is the first SMU for that DDTS. In rare cases in which the same DDTS requires multiple composite SMUs, a second composite version number is released as “002”. In the previous example, a second composite SMU “comp-002.CSCec98766” would be created for DDTS CSCec98766. | |

Filename Component Description

The filename components for all packages are described in [Table 3: Composite- and Single-Package Filename Components, on page 5](#).

Table 3: Composite- and Single-Package Filename Components

| Component | Description |
|-----------------------|--|
| <i>platform</i> | Identifies the platform for which the software package is designed. <ul style="list-style-type: none"> The platform designation is “hfr.” |
| <i>composite_name</i> | Identifies a specific composite package. <ul style="list-style-type: none"> The only composite PIE file at this time is named “mini” and includes all packages described in the Cisco IOS XR Unicast Routing Core Bundle. |

| Component | Description |
|---------------------|--|
| <i>package_type</i> | Identifies the type of package the file supports (<i>package_type</i> applies only to single-package PIEs). Package types include: <ul style="list-style-type: none"> • mcast—Multicast package • mgbl—Manageability package • mpls—MPLS package • k9sec—Security package • diags—Diagnostics package • fpd—Field-programmable device package • cgn—Carrier Grade NAT package • doc—Documentation package |
| <i>major</i> | Identifies the major release of this package. <ul style="list-style-type: none"> • A major release occurs when there is a major architectural change to the product (for example, a major new capability is introduced). • All packages operating on the router must be at the same major release level. • A major release is the least frequent release and may require a router reboot. |
| <i>minor</i> | Identifies the minor release of this package. <ul style="list-style-type: none"> • A minor release contains one or more of the following: <ul style="list-style-type: none"> • New features • Bug fixes • The minor release version does not have to be identical for all software packages operating on the router, but the operating packages must be certified by Cisco as compatible with each other. • A minor release may require a router reboot. |
| <i>maintenance</i> | Identifies the maintenance release of this package. <ul style="list-style-type: none"> • A maintenance release contains a collection of bug fixes for a package. • The maintenance release version does not have to be identical for all software packages operating on the router, but the major and minor versions of the maintenance release must match those of the package being updated. • A maintenance release does not usually require a router reboot. |
| <i>ddts</i> | SMUs only. Identifies a DDTS ¹ number that describes the problem this SMU addresses. DDTS is the method used to track known bugs and the resolutions or workarounds for those issues. |
| <i>px</i> | Identifies images that are compatible with hardware that uses the x86 architecture. Starting with Cisco IOS XR Release 4.2, -px releases replace the -p releases. |

¹ distributed defect tracking system

Copying the PIE File to a Local Storage Device or Network Server

To add an optional package or upgrade or downgrade a package, you must copy the appropriate PIE file to a local storage device or to a network file server to which the router has access.

If you need to store PIE files on the router, we recommended storing PIE files on the hard disk. Flash disk0: serves as the boot device for packages that have been added or activated on the system. Flash disk1: is used as a backup for disk0:.



Tip Before copying PIE files to a local storage device, use the **dir** command to check to see if the required PIE files are already on the device.

Information About Package Management

Summary of Package Management

The general procedure for adding optional packages, upgrading a package or package set, or downgrading packages on the router is as follows:

1. Copy the package file or files to a local storage device or file server.
2. Add the package or packages on one or more secure domain routers (SDRs) using the command **install add**.
3. Activate the package or packages on one or more SDRs using the **install activate** command.
4. Commit the current set of packages using the **install commit** command.

Figure 1: [Process to Add, Activate, and Commit Cisco IOS XR Software Packages, on page 7](#) illustrates key steps in the package management process.

Figure 1: Process to Add, Activate, and Commit Cisco IOS XR Software Packages

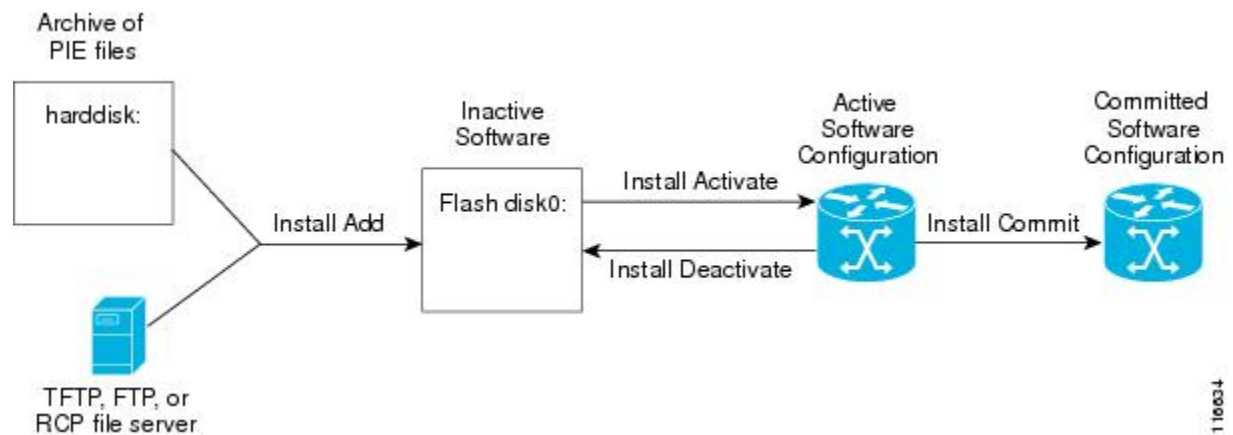

110034

Adding Packages

Use the **install add** command to unpack the package software files from a PIE file and copy them to the boot device (usually disk0:).

- From administration EXEC mode, the package software files are added to the boot device of the designated secure domain router system controller (DSDRSC) for a specific SDR specified by the **sdr** keyword in the **install add** command.
- From EXEC mode, the package software files are added to the boot device of the DSDRSC for the current SDR only.
- Package software files are also added to the standby DSDRSC for any SDR to which the package is added. This ensures that the files are available to the standby if there is a redundancy switchover. The package files are also added to any additional installed DRPs.
- In addition, package software files are added to all active and standby Route Processors (RPs), even if they are not acting as a DSC or DSDRSC, as well as active and standby fabric shelf controllers (SCs).



Note The disk that holds the unpacked software files is also known as the *boot device*. By default, flash disk0: is used as the boot device. To use an alternate storage device, such as flash disk1:, see the *Router Recovery with ROM Monitor* module of *ROM Monitor Configuration Guide for Cisco CRS Routers*. Remember that all RPs in a system must use the same boot device. If the boot device on the primary RP is flash disk0:, then the standby RP or DRP must also have a flash disk0:.

Verifying Package Details

Before you activate a package on the router, you can verify the type of upgrade that is required for the package and whether the package requires a router reload or not. Use the **show install package pie detail** command in admin mode.

```
RP/0/RP0/CPU0:router(admin)# show install package disk0:hfr-px-4.x.x.04I.CSCuc66088-0.0.4.i
detail

Mon Nov 19 09:44:24.036 UTC
disk0:hfr-px-4.x.x.04I.CSCuc66088-0.0.4.i
  asr9k-px-4.x.x.04I.CSCuc66088 V0.0.4.i[SMU]  User specified bundle
    iosxr-infra-hfr-px1-4.x.x.04I.CSCuc66088.pi.pie.
      [composite package]
      [root package, grouped contents]
  Vendor : Cisco Systems
  Desc   : User specified bundle iosxr-infra-hfr-px1-4.x.x.04I.CSCuc66088.pi.pie.
  Build  : Built on Fri Nov  9 11:00:11 UTC 2012
  Source : By iox-bld27 in /scratch1/SMU_BLD_WS/ci-431_206626_CSCuc66088_121109102249 for
  pie
  Card(s): RP, CRS-RP-X86, CRS8-RP-x86, CRS16-RP-x86, ASR9001-RP, RP-STARSCREAM,
  NP24-4x10GE,
    NP24-40x1GE, NP40-40x1GE, NP40-4x10GE, NP40-8x10GE, NP40-2_20_COMBO, NP80-8x10GE,
    NP80-16x10GE, NP200-24x10GE, NP200-36x10GE, NP200-2x100GE, NP200-1x100GE,
  NP200-5x40GE,
    NP200-8x10GE, NP200-MOD-SMEM, NP200-MOD-LMEM, ASR9001-LC, A9K-SIP-700,
  A9K-SIP-500, A9K-SIP-AVSM
  Restart information:
    Default:
      parallel impacted processes restart
  Size Compressed/Uncompressed: 1744KB/1830KB (95%)
```



```

Components in package disk0:asr9k-px-4.x.x.04I.CSCuc66088-0.0.4.i, package
hfr-px-4.x.x.04I.CSCuc66088:
  disk0:iosxr-infra-4.x.x.04I.CSCuc66088-0.0.4.i
    iosxr-infra-4.x.x.04I.CSCuc66088 V0.0.4.i[SMU]  IOS-XR Infra Package Definition
      Vendor : Cisco Systems
      Desc   : IOS-XR Infra Package Definition
      Build  : Built on Fri Nov  9 11:00:10 UTC 2012
      Source : By iox-bld27 in /scratch1/SMU_BLD_WS/ci-431_206626_CSCuc66088_121109102249
for pie
  Card(s): RP, CRS-RP-X86, CRS8-RP-x86, CRS16-RP-x86, ASR9001-RP, RP-STARSCREAM,
NP24-4x10GE,
          NP24-40x1GE, NP40-40x1GE, NP40-4x10GE, NP40-8x10GE, NP40-2_20_COMBO,
NP80-8x10GE,
          NP80-16x10GE, NP200-24x10GE, NP200-36x10GE, NP200-2x100GE, NP200-1x100GE,
          NP200-5x40GE, NP200-8x10GE, NP200-MOD-SMEM, NP200-MOD-LMEM, ASR9001-LC,
          A9K-SIP-700, A9K-SIP-500, A9K-SIP-AVSM

Size Compressed/Uncompressed: 1744KB/1830KB (95%)
Components in package disk0:iosxr-infra-4.x.x.04I.CSCuc66088-0.0.4.i,
package iosxr-infra-4.x.x.04I.CSCuc66088:
platforms-spa-chopper V[ci-4x-bugfix/8] This component contains Platform
Independent
Chopper SPA Code.
iosxr-infra-4.x.x.04I.CSCuc66088-package V[Default] Manifest information for
package
iosxr-infra-4.x.x.04I.CSCuc66088
iosxr-infra-4.x.x.04I.CSCuc66088-package-compatibility V[Default]
Package Compatibility information for package iosxr-infra-4.x.x.04I.CSCuc66088

```

Activating Packages

Software packages remain inactive until activated with the **install activate** command.

After a package has been added to the SDR, use the **install activate** command to activate the package or SMUs for all valid cards. Information within the package is used to verify compatibility with the target cards and with the other active software. Actual activation is performed only after the package compatibility and application programming interface (API) compatibility checks have been passed.



Note SDR-specific activation is supported for specific packages and upgrades, such as optional packages and SMUs. Packages that do not support SDR-specific EXEC mode activation can only be activated for all SDRs simultaneously from administration EXEC mode.

Activating a Package for all Secure Domain Routers

To activate a package for all secure domain routers (SDRs) in the system, use the **install activate** command in administration EXEC mode. If used in administration EXEC mode, the **install activate** command also activates the package on all administration plane nodes and resources, including service processors (SPs), fabric SCs, fan controllers, alarm modules, and power modules.



Note To enter administration EXEC mode, you must be logged in to the owner secure domain router (SDR) and have root-system access privileges.

Activating a Package for a Single SDR

- To activate a package for a specific SDR from administration EXEC mode, use the **install activate** command with the **sdr** keyword and *sdr-name* argument. This will also activate the package on all administration plane nodes and resources.
- To activate a package when logged in to the SDR, use the **install activate** command in EXEC mode.

Activating Multiple Packages or SMUs

To install multiple packages or software maintenance upgrades (SMUs) with a single command, use the **install activate** command and either specify up to 16 packages by repeating *device: package* arguments or use wildcard syntax to specify multiple packages. Some SMUs may require a reload. If the operation requires a node reload, the user is prompted before the installation operation occurs.

Related Topics

[SMU Installation Combinations](#)

Activating All Packages Added in a Specific Operation

To install all packages that were added in a specific **install add** operation, use the **install activate** command with the **id add-id** keyword and argument, specifying the operation ID of the **install add** operation. You can specify up to 16 operations in a single command.

Adding and Activating a Package with a Single Command

To add and activate a package with a single command, use the **install add** command with the **activate** keyword.

- To add and activate a package for all SDRs, enter the **install add** command with the **activate** keyword from administration EXEC mode. To add and activate a package for a specific SDR, from administration EXEC mode enter the **install add** command with the **activate** and the **sdr** keywords.
- To add and activate a package on a non-owner SDR, enter the **install add** command with the **activate** keyword from EXEC mode.

Upgrading and Downgrading Packages

To upgrade a package, activate the latest version of the package; the previous version is automatically deactivated. To downgrade a package, activate the previous version of the package; the latest version is automatically deactivated.

Actual activation is performed only after compatibility checks have been passed.



Note

- Activating a software maintenance upgrade (SMU) does not cause previous versions of the SMUs, or the package to which the SMU applies, to be automatically deactivated.
- If you upgrade an ASR 9000 router with low RSP card memory, then the RSP440-TR route-switch processor and Cisco ASR 9000 2nd Generation line card can become inaccessible due to insufficient memory. Power cycling the router may help bring the router back to the up state.

Committing the Active Software Set

When a package is activated for one or more SDRs, it becomes part of the current running configuration for those SDRs. To make the package activation persistent across reloads, enter the **install commit** command. On startup, the designated secure domain router shelf controller (DSRSC) of the secure domain router (SDR) loads the committed software set.

- To commit the active software set for a specific SDR from administration EXEC mode, use the **install commit** command with the **sdr sdr-name** keyword and argument.
- To commit the active software set for all SDRs in the system, use the **install commit** command without keywords or arguments in administration EXEC mode.



Note If the system is restarted before the active software set is saved with the **install commit** command, the previously committed software set is used.

Rolling Back to a Previous Installation Operation

Although the term *commit* sounds final, the Cisco IOS XR software provides the flexibility to roll back the selected package set to previously saved package sets. Each time a package is activated or deactivated, a rollback point is created that defines the package set that is active after the package activation or deactivation. The software also creates a rollback point for the last committed package set. If you find that you prefer a previous package set over the currently active package set, you can use the **install rollback** command to make a previously active package set active again.

Related Topics

[Rolling Back to a Previous Software Set](#), on page 55

Multiple Disks Support during Installations

In installations on platforms where Cisco IOS XR Software is supported, only a single disk is used as an install device; that is, either disk0 or disk1. When multiple packages are installed on a single disk, it results in space constraints. To resolve this space limitation, the disk supported for the install operations has been extended to another disk called the disk1. When installing multiple packages, this feature enables you to choose between disk0 and disk1.

To add packages to a specific disk name, use the **install media** command in the admin configuration mode.

```
RP/0/RSP0/CPU0: router (admin) # install media disk1
```

Restrictions

- Before enabling the addition of disk1 through the **install media** command, the disk mirroring feature should be explicitly disabled. For details regarding disk mirroring, see the Disk Mirroring chapter.
- All single version packages should be installed into one disk; that is, either disk0 or disk1.
- When downgrading to an image that does not support extended disk, the rollback points of the extended disk will not be available on the downgraded image. For example, assume a case where the version1 (V1) image does not support the extended disk functionality and version2 (V2) image supports the functionality. Upgrading from V1(disk0) to V2(disk1), in such a case, makes the rollback points of V1 available on V2. However, when downgrading from V2(disk1) to V1(disk0), the rollback points of V2

will not be available on V1. For more information about the rollback feature and rollback points, see the Upgrading and Managing Software chapter.

Deactivation of fully superseded SMUs

Cisco IOS XR Software will accumulate a set of Software Maintenance Upgrades (SMUs) over time, where an older SMU gets superseded by the latest SMU. For example, if SMU A was initially delivered to you, and subsequently, as a result of a bug resolution, SMU B was delivered, then SMU A becomes the subset of SMU B and SMU A is superseded by SMU B. In this case, SMU A is redundant and can be deactivated to clean up the software package.

To deactivate all the fully superseded SMUs, use the **install deactivate superseded** command in the admin mode.

```
RP/0/RSP0/CPU0: router(admin) # install deactivate superseded
```

To display the details of the SMUs that are superseded, use the **show install superseded** command in the EXEC mode.

```
RP/0/RSP0/CPU0: router # show install superseded
Thu Feb 3 17:37:20.379 UTC
disk0:asr9k-px-4.3.0.CSCud93518-1.0.0 is fully superseded by
disk0:asr9k-px-4.3.0.CSCue23747-1.0.0
```

Support for the Ignore Package Presence Check Option

During any software package upgrade in Cisco IOS XR Software, two versions of the packages get stored, both the previous version and the upgraded version. In Route Switch Processor 2 (RSP2), the disk space is insufficient to hold all packages of these two versions. To address this, a new optional keyword, **ignore-pkg-presence-check**, is added to the **install activate** command, which allows upgrading with lesser number of packages. For example, assume a case where version1 (V1) of the software consists of packages A, B, C, and D, and you want to upgrade to the version2 (V2) with only 3 packages (A, B, and C). The **ignore-pkg-presence-check** option allows only packages A, B, and C to be upgraded to V2 and deactivates package D of V1. Thus, an explicit deactivation of package D is not required and the user can add package D of V1 after upgrading to V2.

To upgrade software with lesser number of packages, use the **install activate [ignore-pkg-presence-check] V2 packages** command in the admin mode.

```
RP/0/RSP0/CPU0: router(admin) # install activate [ignore-pkg-presence-check] V2 packages
```

Restrictions

The restrictions for this option are:

- The **ignore-pkg-presence-check** keyword is supported only with the **install activate** command and is not supported with the **install add activate** command.
- When you upgrade using the **ignore-pkg-presence-check** option, the deactivation of packages always happens synchronously, using the synchronous keyword in the **install deactivate** command.

Managing Software Operations in Secure Domain Routers

Most installation operations can be performed for all SDRs, or for a specific SDR. Installation operations, such as adding and activating software packages, are performed in either administration EXEC mode or EXEC mode.

- Installation operations performed in administration EXEC mode can impact a single SDR, or all SDRs in the system. To access administration EXEC mode, you must be a member of the root-system user group.
- Installation operations performed in EXEC mode can impact only the SDR to which the user is logged in.

For more information, review the other sections in this document. See also the following Cisco documents:

- *Software Package Management Commands on the Cisco IOS XR Software module of System Management Command Reference for Cisco CRS Routers*
- *Configuring Secure Domain Routers on Cisco the Cisco IOS XR Software module of this book.*

Related Topics

[Summary of Cisco IOS XR Software Packages](#), on page 3

Managing Software Packages in a Multishelf System

Software operations in a multishelf system are the same as in a single-shelf system: software packages are added and activated on one or more SDRs from either administration EXEC mode or from EXEC mode. The DSC keeps track of software operations for the entire system, while the DSDRSC of each SDR manages the software operations for that specific SDR. Installation operations for a specific SDR can also be performed from administration EXEC mode for many features.

- When an installation operation is performed in administration EXEC mode, the software packages and related configurations are synchronized throughout a multishelf system by the designated shelf controller (DSC), using the Ethernet control network, as shown in [Figure 2: DSC in a CRS-1/M-F1 Multishelf System, on page 14](#). The DSC maintains an inventory of the packages, versions, and configurations for each node in the system.
- When an installation operation is performed in EXEC mode, the software packages and related configurations are synchronized throughout the nodes assigned to that SDR by the designated secure domain router shelf controller (DSDRSC). The DSDRSC maintains an inventory of the packages, versions, and configurations for each node in the SDR.

See the *Software Package Management Commands on Cisco IOS XR Software* module of *System Management Command Reference for Cisco CRS Routers* or more information on SDR support for each **install** command.



Note Whenever a new chassis or node is added to the system, the DSC verifies that the software configuration for that chassis is correct and downloads any required packages and configurations. The active RP in each chassis then distributes and manages the software and configurations for the cards and equipment in that chassis.

Figure 2: DSC in a CRS-1/M-F1 Multishelf System

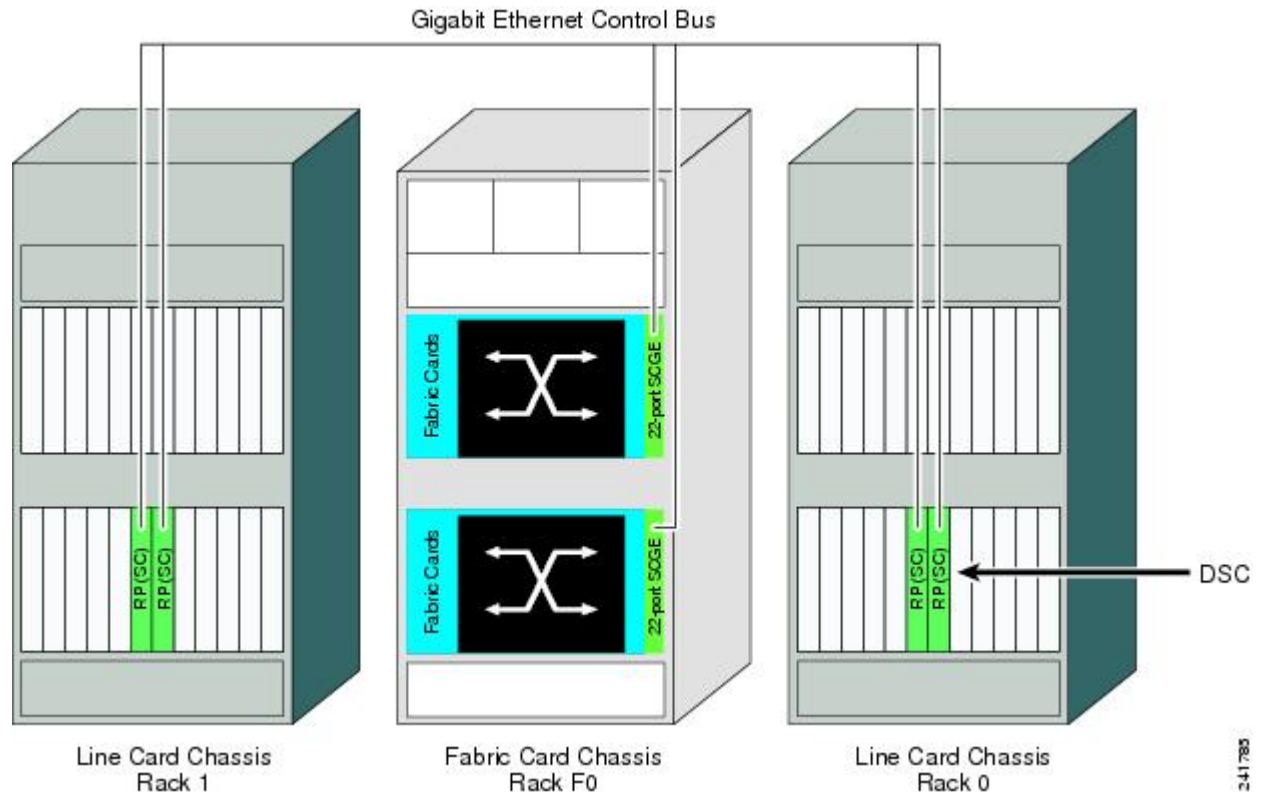

2-41783

Default Software Profile for New SDRs

When a new non-owner SDR is created, the nodes assigned to that SDR are activated with the default software profile. The default profile is the active software set for the owner SDR. The owner SDR is the default SDR accessed by logging into the DSC of the system.

To view the default software profile, use the **show install active summary** command in administration EXEC mode. Any new nodes that are configured to become a part of an SDR will boot with the default software profile listed in the output of this command.

```
RP/0/RP0/CPU0:router(admin)# show install active summary
```

```
Default Profile:
SDRs:
  Owner
  sdr1
Active Packages:
disk0:hfr-diags-3.3.0
disk0:hfr-mgbl-3.3.0
disk0:hfr-mcast-3.3.0
disk0:hfr-mpls-3.3.0
disk0:hfr-k9sec-3.3.0
disk0:hfr-mini-3.3.0
```

Upgrading Packages

To upgrade a package that is currently active on your SDR, add and activate a newer version of the same package (see [Figure 3: Example of a Maintenance Release Package Upgrade, on page 15](#)). The older version of the software package is deactivated automatically. These actions are permitted only after the package compatibility checks and API version compatibility checks have been passed.

Deactivated packages are not removed from the router. To remove inactive package files, use the **install remove** command.



Caution

Upgrading or downgrading a software package can cause a process to restart or a new process to start. Use the **test** option to preview the impact of the package activation.

Figure 3: Example of a Maintenance Release Package Upgrade

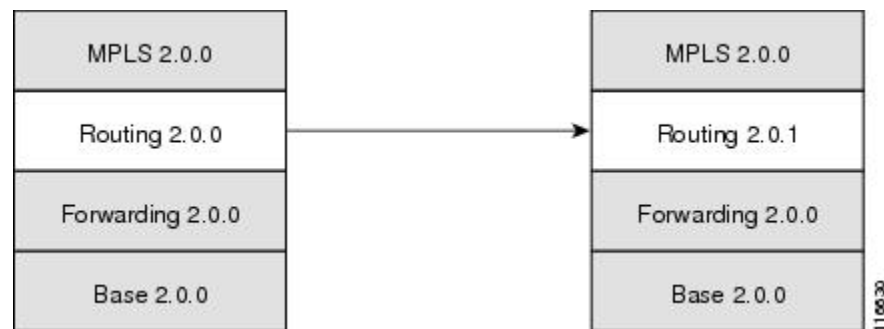

Related Topics

[Deactivating and Removing Cisco IOS XR Software Packages, on page 49](#)

Downgrading Packages

To downgrade a software package, activate an older version on one or more cards for which that package is already active. The newer version of the same software package is deactivated automatically. These actions are performed only after the package compatibility checks and API version compatibility checks have been passed.

Deactivated packages are not removed from the router. To remove inactive package files, use the **install remove** command. See the *Related Topics* section for links to more information.



Note

Downgrading to Cisco IOS XR Software Release 3.7.0 or earlier releases is not supported if you are using a FAT32 flash disk. If you are using a FAT32 flash disk, and you must downgrade, convert the flash disk to FAT16 before downgrading. If you do not convert the flash disk to FAT16 before the downgrade, the disk becomes unreadable and the router does not boot. Converting from FAT32 to FAT16 is a complex procedure. If you need to convert a FAT32 disk to FAT16, contact Cisco technical support for guidance.

Related Topics

[Deactivating and Removing Cisco IOS XR Software Packages, on page 49](#)

Impact of Package Version Changes

Each package version change has a different impact on the operation of the router, depending on the type of package and whether the upgrade is for a major, minor, or maintenance release. The following resources can provide more information on the impact of a package version change:

- See *Related Topics* for more information on the typical impact for major, minor, and maintenance releases.
- For specific information about the impact of an upgrade, consult the release notes for the package release, and test the impact of the package activation by adding the test option to the **install activate** command.
- The Cisco IOS XR Software Selector tool also contains information on package version compatibility.

Related Topics

[PIE Filenames and Version Numbers](#), on page 4

[Obtaining and Placing Cisco IOS XR Software](#), on page 21

Impact of Package Activation and Deactivation

Activation or deactivation of a package can have an immediate impact on the system. The system can be affected in the following ways:

- When a new package is activated, any new CLI commands for the package are added to the SDRs impacted by the new software . The router need not be restarted or reloaded.
- When a package is deactivated, the commands associated with the features being deactivated are removed from any SDR impacted by the operation . The commands are no longer available to the user.
- During a software package deactivation, upgrade, or downgrade, any incompatible configurations are removed from the running configuration of any SDR impacted by the operation , and saved to a file. Messages for incompatible configurations are displayed. Incompatible configurations are those configurations that are not supported by the new version of the software package.



Note You must address any issues that result from the revised configuration and reapply the configuration, if necessary.

- New processes may be started.
- Running processes may be stopped or restarted.
- All processes in the cards may be restarted. Restarting processes in the cards is equivalent to a soft reset.
- The cards may reload.
- No impact: no processes in the card may be affected.



Tip When activating and deactivating packages, use the **test** option to test the effects of a command without impacting the running system. After the activation or deactivation process completes, enter the **show install log** command to display the process results.

Concurrent Installation Operations in an SDR

Multiple installation operations can be performed in different SDRs at the same time, as long as they do not impact the same node. In other words, only one **install** command can run on a node at a time.

Installation operations performed on an SDR impact only the nodes assigned to that SDR, so operations can be performed on both SDRs at the same time. If a user performs an installation operation to one or more SDRs from administration EXEC mode, users of the effected SDRs can still perform additional installation operations as long as they do not impact the same nodes.

If a second installation operation impacts the same nodes as another incomplete install operation, then the new CLI is rejected until the first operation is complete.

Delaying the Return of the CLI Prompt

By default, the CLI prompt is returned to the screen before the installation operation is complete, which allows you to enter other commands that are not installation commands. If additional installation requests are attempted before the first operation is complete, they are not run.

To delay the return of the CLI prompt until an installation operation is complete, enter the **install** command with the **synchronous** keyword. For example:

```
install add disk1:/pie-file synchronous
install activate disk0:package synchronous
```

To determine if an **install** command is currently running, enter the **show install request** command.

Displaying Installation Log Information

The install log provides information on the history of the installation operations. Each time an installation operation is run, a number is assigned to that operation.

- Use the **show install log** command to display information about both successful and failed installation operations.
- The **show install log** command with no arguments displays a summary of all installation operations. Specify the *request-id* argument to display information specific to an operation. Use the **detail** or **verbose** keywords to display details for specific operation.
- Use the **detail** or **verbose** keywords to display detailed information, including file changes, nodes that could be reloaded, impact to processes, and impact to Dynamic Link Libraries (DLLs).



Tip By default, the install log stores up to 50 entries. Use the **clear install log-history** command to reset the number of entries to any value from 0 to 255.

Examples

Displaying install log Entries: Example

The following example displays information for the install requests. Use the **verbose** keyword to display detailed information, including files changes, impact to processes, and impact to DLLs.

```
RP/0/RP0/CPU0:router(admin)# show install log verbose
```

```
Install operation 1 started by user 'labuser' at 17:48:51 UTC Sat Jun 03 2006.
install add /disk1:hfr-diags-p.pie-PD34-06.06.07
```

```

/disk1:hfr-k9sec-p.pie-PD34-06.06.07 /disk1:hfr-mcast-p.pie-PD34-06.06.07
/disk1:hfr-mgbl-p.pie-PD34-06.06.07 /disk1:hfr-mpls-p.pie-PD34-06.06.07
Install operation 1 completed successfully at 17:51:32 UTC Sat Jun 03 2006.

Install logs:
Install operation 1 'install add /disk1:hfr-diags-p.pie-PD34-06.06.07
/disk1:hfr-k9sec-p.pie-PD34-06.06.07 /disk1:hfr-mcast-p.pie-PD34-06.06.07
/disk1:hfr-mgbl-p.pie-PD34-06.06.07 /disk1:hfr-mpls-p.pie-PD34-06.06.07'
started by user 'labuser' at 17:48:51 UTC Sat Jun 03 2006.
Info:      The following packages are now available to be activated:
Info:
Info:      disk0:hfr-diags-3.4.0.1I
Info:      disk0:hfr-k9sec-3.4.0.1I
Info:      disk0:hfr-mcast-3.4.0.1I
Info:      disk0:hfr-mgbl-3.4.0.1I
Info:      disk0:hfr-mpls-3.4.0.1I
Info:
Install operation 1 completed successfully at 17:51:32 UTC Sat Jun 03 2006.

Install operation 2 started by user 'labuser' at 18:06:32 UTC Sat Jun 03 2006.
install activate disk0:hfr-diags-3.4.0.1I disk0:hfr-k9sec-3.4.0.1I
disk0:hfr-mcast-3.4.0.1I disk0:hfr-mgbl-3.4.0.1I disk0:hfr-mpls-3.4.0.1I
Install operation 2 completed successfully at 18:07:48 UTC Sat Jun 03 2006.

Summary:
Install method: parallel
Summary of changes on nodes 0/1/SP, 0/6/SP, 0/SM0/SP, 0/SM1/SP, 0/SM2/SP,
0/SM3/SP:
  Activated:   hfr-diags-3.4.0.1I
  No processes affected

Summary of changes on nodes 0/1/CPU0, 0/6/CPU0:
  Activated:   hfr-diags-3.4.0.1I
               hfr-mcast-3.4.0.1I
               hfr-mpls-3.4.0.1I
  1 hfr-mpls processes affected (0 updated, 1 added, 0 removed, 0 impacted)
  2 hfr-mcast processes affected (0 updated, 2 added, 0 removed, 0 impacted)

Summary of changes on nodes 0/RP0/CPU0, 0/RP1/CPU0:
  Activated:   hfr-diags-3.4.0.1I
               hfr-k9sec-3.4.0.1I
               hfr-mcast-3.4.0.1I
               hfr-mgbl-3.4.0.1I
               hfr-mpls-3.4.0.1I
  6 hfr-mgbl processes affected (0 updated, 6 added, 0 removed, 0 impacted)
  8 hfr-mpls processes affected (0 updated, 8 added, 0 removed, 0 impacted)
  7 hfr-k9sec processes affected (0 updated, 7 added, 0 removed, 0 impacted)
  14 hfr-mcast processes affected (0 updated, 14 added, 0 removed, 0 impacted)

Install logs:
Install operation 2 'install activate disk0:hfr-diags-3.4.0.1I
disk0:hfr-k9sec-3.4.0.1I disk0:hfr-mcast-3.4.0.1I disk0:hfr-mgbl-3.4.0.1I
disk0:hfr-mpls-3.4.0.1I' started by user 'labuser' at 18:06:32 UTC Sat Jun
03 2006.
Info:      The changes made to software configurations will not be
Info:      persistent across system reloads. Use the command 'admin install
Info:      commit' to make changes persistent.
Info:      Please verify that the system is consistent following the
Info:      software change using the following commands:
Info:      show system verify
--More--

```

The following example displays information for a specific install request. Use the **detail** keyword to display additional information, including impact to processes and nodes impacted.

```
RP/0/RP0/CPU0:router(admin)# show install log 2 detail

Install operation 2 started by user 'labuser' at 18:06:32 UTC Sat Jun 03 2006.
install activate disk0:hfr-diags-3.4.0.1I disk0:hfr-k9sec-3.4.0.1I
disk0:hfr-mcast-3.4.0.1I disk0:hfr-mgbl-3.4.0.1I disk0:hfr-mpls-3.4.0.1I
Install operation 2 completed successfully at 18:07:48 UTC Sat Jun 03 2006.

Summary:
  Install method: parallel
  Summary of changes on nodes 0/1/SP, 0/6/SP, 0/SM0/SP, 0/SM1/SP, 0/SM2/SP,
  0/SM3/SP:
    Activated:      hfr-diags-3.4.0.1I
    No processes affected

  Summary of changes on nodes 0/1/CPU0, 0/6/CPU0:
    Activated:      hfr-diags-3.4.0.1I
                   hfr-mcast-3.4.0.1I
                   hfr-mpls-3.4.0.1I
    1 hfr-mpls processes affected (0 updated, 1 added, 0 removed, 0 impacted)
    2 hfr-mcast processes affected (0 updated, 2 added, 0 removed, 0 impacted)

  Summary of changes on nodes 0/RP0/CPU0, 0/RP1/CPU0:
    Activated:      hfr-diags-3.4.0.1I
                   hfr-k9sec-3.4.0.1I
                   hfr-mcast-3.4.0.1I
                   hfr-mgbl-3.4.0.1I
                   hfr-mpls-3.4.0.1I
    6 hfr-mgbl processes affected (0 updated, 6 added, 0 removed, 0 impacted)
    8 hfr-mpls processes affected (0 updated, 8 added, 0 removed, 0 impacted)
    7 hfr-k9sec processes affected (0 updated, 7 added, 0 removed, 0 impacted)
    14 hfr-mcast processes affected (0 updated, 14 added, 0 removed, 0 impacted)

Install logs:
  Install operation 2 'install activate disk0:hfr-diags-3.4.0.1I
  disk0:hfr-k9sec-3.4.0.1I disk0:hfr-mcast-3.4.0.1I disk0:hfr-mgbl-3.4.0.1I
  disk0:hfr-mpls-3.4.0.1I' started by user 'labuser' at 18:06:32 UTC Sat Jun
  03 2006.
  Info:      The changes made to software configurations will not be
  Info:      persistent across system reloads. Use the command 'admin install
  Info:      commit' to make changes persistent.
  Info:      Please verify that the system is consistent following the
  Info:      software change using the following commands:
  Info:      show system verify
  Info:      install verify packages
  Install operation 2 completed successfully at 18:07:48 UTC Sat Jun 03 2006.
```

Package Management Procedures



Note Review the concepts about package management before performing the tasks described in this module.

Related Topics

[Information About Package Management](#), on page 7

Activation and Deactivation Prerequisites

These prerequisites must be met for a package to be activated or deactivated:

- You must be in a user group associated with a task group that includes the proper task IDs. The command reference guides include the task IDs required for each command. If you suspect user group assignment is preventing you from using a command, contact your AAA administrator for assistance.
- Verify that all cards are installed and operating properly. For example, do not activate or deactivate packages while cards are booting, while cards are being upgraded or replaced, or when you anticipate an automatic switchover activity.
- If a ROM Monitor upgrade is required for the software package, the upgrade must be completed before the package is activated. For ROM Monitor upgrade information and procedures, see *ROM Monitor Configuration Guide for Cisco CRS Routers*.
- Check the sanity of the configuration file system and recover from any internal inconsistencies by using the **cfs check** command.

```
RP/0/RP0/CPU0:router# cfs check
```

```
Tue Sep 20 07:22:03.374 DST
```

```
Creating any missing directories in Configuration File system...OK
Initializing Configuration Version Manager...OK
Syncing commit database with running configuration...OK
```

- Clear any inconsistency alarms and remove any failed configurations using the **clear configuration inconsistency** command.

An inconsistency alarm is set when there is a failure to restore the configuration; this can occur during router startup, or when a line card, modular services card (MSC), or route processor (RP) card is inserted or removed. If an inconsistency alarm is set, a message similar to the one in this example is displayed:

```
RP/0/0/CPU0:May 26 11:58:40.662 : cfgmgr-rp[130]: %MGBL-CONFIGCLI-3
  BATCH_CONFIG_FAIL : 28 config(s) failed during startup. To view
  failed config(s) use the command - "show configuration failed startup"
```

When the inconsistency alarm is set, all configuration commit operations fail until the alarm is cleared.

- Although more than one version of a software package can be added to a storage device, only one version of a package can be active for any card.
- Some packages require the activation or deactivation of other packages.
- The package being activated must be compatible with the current active software set.
- SDR-specific activation is supported for specific packages and upgrades, such as optional packages and SMUs. Packages that do not support SDR-specific activation can only be activated for all SDRs simultaneously from administration EXEC mode.

Activation is performed only after the package compatibility checks and API version compatibility checks have been passed. If a conflict is found, an on-screen error message is displayed.

While a software package is being activated, other requests are not allowed to run on any of the impacted nodes. Package activation is completed when a message similar to this one appears:

```
Install operation 2 completed successfully at 20:30:29 UTC Mon Nov 14 2005.
```

Each CLI install request is assigned a request ID, which can be used later to review the events.

Obtaining and Placing Cisco IOS XR Software

This section contains information to locate the available software packages and to transfer them either to a local storage device or to a network server. When this is done, the package or packages can be added and activated on one or more SDRs .

There are two primary ways to obtain packages in Cisco IOS XR software:

- Request the software from Cisco on a flash disk that you can insert into the removable flash disk slot (usually flash disk1:). Flash disk1: is optional. When it is installed, flash disk1: can be used to store PIE files, which can then be used to add new software to the boot device (usually flash disk0:).
- Download the Cisco IOS XR software packages to a local storage device of the DSC, such as flash disk1:, or to a remote server, such as a tftp or rcp server.

The boot device is the local disk on the DSC where Cisco IOS XR software is added and activated. PIE files should not be stored on this boot device. The default boot device is disk0:. All PIE files should be stored on flash disk1:.

Transferring Installation Files from a Network File Server to a Local Storage Device

If the Cisco IOS XR software PIE files are located on a remote TFTP, FTP, SFTP, or rcp server, you can copy the files to a local storage device such as disk1:. When the PIE files are located on a local storage device, the software packages can be added and activated on the router from that storage device. [Table 4: Download Protocols Supported by Cisco IOS XR Software, on page 21](#) describes the supported server protocols, and the CLI syntax used copy files from each server type to the local storage device.



Tip Cisco IOS XR software PIE files can also be added to the router boot device directly from the remote server.



Note Consult your system administrator for the location and availability of your network server.

Table 4: Download Protocols Supported by Cisco IOS XR Software

| Name | Description |
|--------------------------------|---|
| Trivial File Transfer Protocol | TFTP allows files to be transferred from one computer to another over a network, usually without the use of client authentication (for example, username and password). It is a simplified version of FTP. Note Some Cisco IOS XR software images may be larger than 32 MB, and the TFTP services provided by some vendors may not support a file this large. If you do not have access to a TFTP server that supports files larger than 32 MB, download the software image using FTP or rcp. |
| File Transfer Protocol | FTP is part of the TCP/IP protocol stack and requires a username and password. |
| Remote Copy Protocol | The rcp protocol uses TCP to ensure the reliable delivery of data, and rcp downloads require a usernames. |

| Name | Description |
|----------------------------|--|
| SSH File Transfer Protocol | SFTP is part of the SSHv2 feature in the Security package and provides for secure file transfers. For more information, see the <i>System Security Configuration Guide for Cisco CRS Routers</i> . |

The router commands listed in [Table 5: Commands for Copying Package Files to the Router, on page 22](#) show how to copy package files to the router using three types of file transfer protocols.

Table 5: Commands for Copying Package Files to the Router

| Server Type | Command and Examples |
|-------------|--|
| TFTP | The following command syntax is used: copy tftp:// hostname_or_ipaddress / directory-path / pie-name disk1: Example: <pre>RP/0/RP0/CPU0:router# copy tftp://10.1.1.1/images/comp-hfr-mini.pie disk1:</pre> |
| FTP | The following command syntax is used: copy ftp:// username : password @ hostname_or_ipaddress / directory-path / pie-name disk1: Example: <pre>RP/0/RP0/CPU0:router# copy ftp://john:secret@10.1.1.1/images/comp-hfr-mini.pie disk1:</pre> |
| rcp | The following command syntax is used: copy rcp:// username @ hostname_or_ipaddress / directory-path / pie-name disk1: Example: <pre>RP/0/RP0/CPU0:router# copy rcp://john@10.1.1.1/images/comp-hfr-mini.pie disk1:</pre> |

[Table 6: Command Variables for Copying and Adding Packages from a Network Server, on page 22](#) describes the command variables for copying packages from a network server.

Table 6: Command Variables for Copying and Adding Packages from a Network Server

| Variable | Description |
|------------------------------|---|
| <i>hostname_or_ipaddress</i> | Host name or IP address of the server that stores the source file. |
| <i>pie-name</i> | Name of the PIE file (package). See the Overview of Cisco IOS XR Software Packages, on page 2 for descriptions of the available packages. |
| <i>username</i> | Required for FTP and rcp only and must be a valid username on the FTP or rcp server. |

| Variable | Description |
|-----------------------|---|
| <i>password</i> | Required for FTP only. If a password is not provided, the networking device accepts anonymous FTP. |
| <i>directory-path</i> | <p>The specified directory should be a directory under the home directory of the user. In the rcp and FTP examples in Table 5: Commands for Copying Package Files to the Router, on page 22, the file being downloaded is in a subdirectory called “images” in the home directory of the user “john.”</p> <p>Note For FTP and rcp services, <i>directory-path</i> is the directory relative to the <i>username</i> home directory. If you want to specify an absolute path for the directory, you must add a "/" following the server address.</p> |

When the installation files have been transferred to a network file server or the router, you are ready to activate or upgrade the software.



Note Files with the `vm` extension are bootable installation files used only to replace all current Cisco IOS XR software. These files are installed from ROM monitor mode and cause significant router downtime. We recommend installing or upgrading software packages using PIE files only, as described in this chapter. See *ROM Monitor Configuration Guide for Cisco CRS Routers* for information on installing from `vm` files.

Related Topics

[Adding and Activating Packages](#), on page 31

[Overview of Cisco IOS XR Software Packages](#), on page 2

Preparing for Software Installation Operations

This section includes instructions to prepare for software installation operations.



Note Activation is performed only after the automatic package compatibility and API version compatibility checks have been passed. If a conflict is found, an on-screen error message is displayed.

Before you begin

Before adding or activating Cisco IOS XR software:

- Update the ROM Monitor software, if necessary.
- Determine if a software change is required.
- Verify that the new package is supported on your system. Some software packages require that other packages or package versions be activated on the SDR, and some packages only support specific cards.
- Review the release notes for important information related to that release and to help determine the package compatibility with your router configuration.
- Verify that the system is stable and prepared for the software changes.

SUMMARY STEPS

1. **admin**
2. **show diag**
3. Update the ROMMON software if necessary.
4. **show install active [sdr sdr-name]**
5. **show install pie-info device:package [brief | detail | verbose]**
6. **verify packages install [sdr sdr-name]**
7. **exit**
8. (Optional) **show system verify start**
9. (Optional) **show system verify [detail | report]**
10. **show clock**

DETAILED STEPS

| | Command or Action | Purpose |
|---------------|--|---|
| Step 1 | admin Example: RP/0/RP0/CPU0:router# admin | Enters administration EXEC mode. |
| Step 2 | show diag Example: RP/0/RP0/CPU0:router(admin)# show diag | Displays the ROMMON software version for all cards in the system. Verify that the correct ROMMON software version is installed before upgrading a Cisco IOS XR software package. Note See <i>Related Topics</i> for information regarding the required ROM Monitor (ROMMON) software version. |
| Step 3 | Update the ROMMON software if necessary. | Updates the ROMMON software. For instructions, see <i>ROM Monitor Configuration Guide for Cisco CRS Routers</i> . |
| Step 4 | show install active [sdr sdr-name] Example: RP/0/RP0/CPU0:router(admin)# show install active | Displays the active software for an SDR or for all SDRs. Use this command to determine what software should be added, upgraded or downgraded on the router, and to compare to the active software report after installation operations are complete. Note You can also display the active packages for a specific node, and view results in detailed or summary mode. See the <i>Software Package Management Commands on the Cisco IOS XR Software</i> module of <i>System Management Command Reference for Cisco CRS Routers</i> for more information. |
| Step 5 | show install pie-info device:package [brief detail verbose] Example: | Displays information imbedded in the package. The following keywords provide three levels of information: |

| | Command or Action | Purpose |
|---------------|--|---|
| | <pre>RP/0/RP0/CPU0:router(admin)# show install pie-info disk1:/hfr-mcast-p.pie-3.8.30</pre> | <ul style="list-style-type: none"> • brief (default)—Displays the expiration date of the file, the size, and the installed package name. The expiration date is used for certifying the package. • detail—Displays the package components, the compatible cards, the expiration date, file size, and the installed package name. • verbose—Displays information from the detail display and sub-component information. <p>Note Always review the release notes for the software package for important information related to that release and to help determine the package compatibility with your router configuration.</p> |
| Step 6 | <p>verify packages install [sdr sdr-name]</p> <p>Example:</p> <pre>RP/0/RP0/CPU0:router(admin)# install verify packages</pre> | <p>Verifies that there are no corrupted software files. The consistency of a previously installed software set is verified against the package file from which it originated. This command can be used as a debugging tool to verify the validity of the files that constitute the packages, to determine if there are any corrupted files. This command also checks for corruptions of installation state files and MBI image files. This command is particularly useful when issued after the activation of a package or upgrading the Cisco IOS XR software to a major release.</p> <p>To perform the command for a specific SDR, use the sdr sdr-name keyword and argument.</p> <p>Note The install verify packages command can take up to two minutes per package to process.</p> |
| Step 7 | <p>exit</p> <p>Example:</p> <pre>RP/0/RP0/CPU0:router(admin)# exit</pre> | <p>Exits administration EXEC mode and returns to EXEC mode.</p> |
| Step 8 | <p>(Optional) show system verify start</p> <p>Example:</p> <pre>RP/0/RP0/CPU0:router# show system verify start</pre> | <p>Starts the system status check.</p> |
| Step 9 | <p>(Optional) show system verify [detail report]</p> <p>Example:</p> <pre>RP/0/RP0/CPU0:router# show system verify</pre> | <p>Displays system status information. A variety of information is displayed including the memory and CPU usage, process status, protocol status, and other status information. Use this information to verify that the system is stable.</p> <p>Enter this command in EXEC mode for each SDR impacted by the installation operation.</p> |

| | Command or Action | Purpose |
|----------------|--|---|
| | | <ul style="list-style-type: none"> • detail—Displays additional information at the card and processor level, including actual numbers. • report—Displays the same information as the default show system verify command <p>Note Although most of the output should display the status “OK,” some processes may show other output, such as “Warning.” This does not specifically indicate a problem. Contact your Cisco technical support representative for more information on the output of this command.</p> |
| Step 10 | show clock Example: RP/0/RP0/CPU0:router# show clock | Verifies that the system clock is correct. Software operations use certificates based on router clock times. |

Related Topics

[Activation and Deactivation Prerequisites](#), on page 20

Examples**Verifying That the ROM Monitor Version Is Correct: Example**

In the following example, the ROM Monitor software version is displayed in the “ROMMON:” field for each card.



Note For instructions to upgrade the ROM Monitor software, see *ROM Monitor Configuration Guide for Cisco CRS Routers*.

```
RP/0/RP0/CPU0:router# admin
RP/0/RP0/CPU0:router(admin)# show diag

CARD 0/1/* : Cisco CRS-1 Series Modular Services Card
  MAIN:  board type 500060
         800-25021-05 rev B0
         dev 079239
         S/N SAD09280BS9
  PCA:   73-7648-08 rev B0
  PID:   CRS-MS
  VID:   V02
  CLEI:  IPUCAC1BAA
  ECI:   132502

PLIM 0/PL1/* : Cisco Carrier Routing System SPA Interface Processor Card
  MAIN:  board type 580070
         800-23819-03 rev C0
         dev N/A
```

```

        S/N SAD094401CR
PCA: 73-8982-06 rev C0
PID: CRS1-SIP-800
VID: V01
CLEI: COUIAAMCAA
ECI: 134912
Interface port config: 0 Ports
Optical reach type: Unknown
Connector type: MT-P

NODE 0/1/SP
Node State : IOS XR RUN
PLD: Motherboard: 0x0025, Processor: 0xda13, Power: N/A
MONLIB: QNXFFS Monlib Version 3.1
ROMMON: Version 1.49(20080319:195528) [CRS-1 ROMMON]

NODE 0/1/CPU0
Node State : IOS XR RUN
PLD: Motherboard: 0x0025, Processor: 0xda13, Power: N/A
MONLIB: QNXFFS Monlib Version 3.0
ROMMON: Version 1.49(20080319:195807) [CRS-1 ROMMON]
--More--

```

Displaying the Active Software for All SDRs or for a Specific SDR: Example

The following example displays the active packages for all SDRs in the system. Use this information to determine if a software change is required:

```

RP/0/RP1/CPU0:router(admin)# show install active summary

Default Profile:
  SDRs:
    Owner
    CE1b
Active Packages:
  disk0:hfr-diags-3.3.30
  disk0:hfr-mgbl-3.3.30
  disk0:hfr-k9sec-3.3.30
  disk0:comp-hfr-mini-3.3.30

```

The following example displays a summary of active packages for a specific SDR:

```

RP/0/RP1/CPU0:router(admin)# show install active summary sdr owner

Active Packages:
  disk0:hfr-diags-3.3.30
  disk0:hfr-mgbl-3.3.30
  disk0:hfr-k9sec-3.3.30
  disk0:comp-hfr-mini-3.3.30

```

Displaying Information About the Contents of a PIE File: Example

In the following example, information is displayed about the manageability PIE. This command displays the expiry date of the package, the cards supported by the package, and other details. Use

this information to verify the compatibility of the package with your system and other software packages.

**Note**

A software activation is performed only after the automatic package compatibility and API version compatibility checks have been passed. If a conflict is found, an on-screen error message is displayed.

```
RP/0/RP0/CPU0:router(admin)# show install pie-info disk1:/
hfr-mgbl-p.pie-3.8.0 detail

Contents of pie file '/disk1:/hfr-mgbl-p.pie-3.8.0':
  Expiry date       : Jan 19, 2007 02:55:56 UTC
  Uncompressed size : 17892613

hfr-mgbl-3.8.0
  hfr-mgbl V3.8.0[00] Manageability Package
  Vendor  : Cisco Systems
  Desc    : Manageability Package
  Build   : Built on Wed May 10 08:04:58 UTC 2006
  Source  : By edde-bld1 in /vws/aga/production/3.8.0/hfr/workspace for c28
  Card(s) : RP, DRP, DRPSC
  Restart information:
    Default:
      parallel impacted processes restart
  Components in package hfr-mgbl-3.8.0, package hfr-mgbl:
    manageability-cwi V[r33x/2] Craft Web Interface related binaries ae
    hfr-feature-ipsla V[r33x/1] IPSLA time stamping feature
    doc-hfr-mgbl V[r33x/2] Contains the man page documentation for hfrs
--More--
```

Verifying That There Are No Corrupted Software Files: Example

The following sample output verifies the consistency of the currently active software against the file from which it originated:

```
RP/0/RP0/CPU0:router# install verify packages

Install operation 2 '(admin) install verify packages' started by user 'admin' via CLI at
07:35:01 UTC Wed May 14 2008.
Info: This operation can take up to 2 minutes per package being verified. Please be
patient.
Info: 0/3/CPU0 [LC] [SDR: Owner]
Info: meta-data: [SUCCESS] Verification Successful.
Info: /install/hfr-lc-3.8.0.02I: [SUCCESS] Verification Successful.
Info: /install/hfr-fwdg-3.8.0.02I: [SUCCESS] Verification Successful.
Info: /install/hfr-admin-3.8.0.02I: [SUCCESS] Verification Successful.
Info: /install/hfr-base-3.8.0.02I: [SUCCESS] Verification Successful.
Info: /install/hfr-os-mbi-3.8.0.02I: [SUCCESS] Verification Successful.
Info: 0/SM1/SP [SP] [Admin Resource]
Info: meta-data: [SUCCESS] Verification Successful.
Info: /install/hfr-admin-3.8.0.02I: [SUCCESS] Verification Successful.
Info: /install/hfr-base-3.8.0.02I: [SUCCESS] Verification Successful.
Info: /install/hfr-os-mbi-3.8.0.02I: [SUCCESS] Verification Successful.
Info: 0/3/SP [SP] [Admin Resource]
Info: meta-data: [SUCCESS] Verification Successful.
Info: /install/hfr-admin-3.8.0.02I: [SUCCESS] Verification Successful.
```

```

Info: /install/hfr-base-3.8.0.02I: [SUCCESS] Verification Successful.
Info: /install/hfr-os-mbi-3.8.0.02I: [SUCCESS] Verification Successful.
Info: 0/RP1/CPU0 [RP] [SDR: Owner]
Info: meta-data: [SUCCESS] Verification Successful.
Info: meta-data: [SUCCESS] Verification Successful.
Info: /install/hfr-os-mbi-3.8.0.02I: [SUCCESS] Verification Successful.
Info: /install/hfr-base-3.8.0.02I: [SUCCESS] Verification Successful.
Info: /install/hfr-admin-3.8.0.02I: [SUCCESS] Verification Successful.
Info: /install/hfr-fwdg-3.8.0.02I: [SUCCESS] Verification Successful.
Info: /install/hfr-lc-3.8.0.02I: [SUCCESS] Verification Successful.
Info: /install/hfr-rout-3.8.0.02I: [SUCCESS] Verification Successful.
Info: 0/RP0/CPU0 [RP] [SDR: Owner]
Info: meta-data: [SUCCESS] Verification Successful.
Info: meta-data: [SUCCESS] Verification Successful.
Info: /install/hfr-os-mbi-3.8.0.02I: [SUCCESS] Verification Successful.
Info: /install/hfr-base-3.8.0.02I: [SUCCESS] Verification Successful.
Info: /install/hfr-admin-3.8.0.02I: [SUCCESS] Verification Successful.
Info: /install/hfr-fwdg-3.8.0.02I: [SUCCESS] Verification Successful.
Info: /install/hfr-lc-3.8.0.02I: [SUCCESS] Verification Successful.
Info: /install/hfr-rout-3.8.0.02I: [SUCCESS] Verification Successful.
Info: Verification Summary:
Info: 0/3/CPU0: SUCCESSFUL. No anomalies found.
Info: 0/SML/SP: SUCCESSFUL. No anomalies found.
Info: 0/3/SP: SUCCESSFUL. No anomalies found.
Info: 0/RP1/CPU0: SUCCESSFUL. No anomalies found.
Info: 0/RP0/CPU0: SUCCESSFUL. No anomalies found.
Info: The system needs no repair.
Info: Install operation 2 completed successfully at 07:46:29 UTC Wed May 14 2008.

```

Verifying the Current System Status: Example

The following example shows how to prepare for system verification:

```
RP/0/RP0/CPU0:router# show system verify start
```

```

Storing initial router status ...
done.

```

The following example shows output from running the **show system verify** command.



Note Although most of the output should display the status “OK,” some processes may show other output, such as “Warning.” This does not specifically indicate a problem. Contact your Cisco technical support representative for more information on the output of this command.

```
RP/0/RP0/CPU0:router# show system verify
```

```

Getting current router status ...
System Verification Report
=====
- Verifying Memory Usage
- Verified Memory Usage           : [OK]
- Verifying CPU Usage
- Verified CPU Usage               : [OK]

- Verifying Blocked Processes

```

```

- Verified Blocked Processes : [OK]
- Verifying Aborted Processes
- Verified Aborted Processes : [OK]
- Verifying Crashed Processes
- Verified Crashed Processes : [OK]

- Verifying LC Status
- Verified LC Status : [OK]
- Verifying QNET Status
Unable to get current LC status info
- Verified QNET Status : [FAIL]

- Verifying GSP Fabric Status
- Verified GSP Fabric Status : [OK]
- Verifying GSP Ethernet Status
  gsp WARNING messages for router
  Current set of gsp ping nodes does not match initial set of nodes
- Verified GSP Ethernet Status : [WARNING]

- Verifying POS interface Status
- Verified POS interface Status : [OK]
- Verifying TenGigE interface Status
- Verified TenGigE interface Status : [OK]

- Verifying TCP statistics
- Verified TCP statistics : [OK]
- Verifying UDP statistics
  tcp_udp_raw WARNING messages for router
  UDP Packets sent has not increased during this period.
- Verified UDP statistics : [WARNING]
- Verifying RAW statistics
- Verified RAW statistics : [OK]

- Verifying RIB Status
- Verified RIB Status : [OK]
- Verifying CEF Status
- Verified CEF Status : [OK]
- Verifying CEF Consistency Status
- Verified CEF Consistency Status : [OK]
- Verifying BGP Status
- Verified BGP Status : [OK]
- Verifying ISIS Status
- Verified ISIS Status : [OK]
- Verifying OSPF Status
- Verified OSPF Status : [OK]

- Verifying Syslog Messages
- Verified Syslog Messages : [OK]

System may not be stable. Please look into WARNING messages.

```

Verifying That the System Clock Is Correct: Example

The following example displays the current system clock setting:

```

RP/0/RP0/CPU0:router# show clock

02:14:51.474 PST Wed Jan 28 2009

```

Adding and Activating Packages

The procedure in this section describes how to upgrade or add Cisco IOS XR software PIE files that are stored on a local storage device, such as a flash disk, or on a remote TFTP, FTP, SFTP, or rcp server. The PIE software file can include any of the following:

- The Cisco IOS XR Unicast Routing Core Bundle (six packages in one composite PIE file)
- Any of the optional packages (one package per PIE file)
- Software maintenance upgrades (SMUs)

When you need to add and activate two or more of the preceding package types, you should add and activate them in the order listed above.



Note When adding and activating two or more packages, optional packages can be activated together. Also, if the operation is a reload, multiple packages can be activated together. For example, five reload SMUs can be activated together or the Cisco IOS XR Unicast Routing Core Bundle plus the SMUs and optional packages can be activated together.

For a description of the software management process, see the *Related Topics* section.

These instructions are also used to downgrade software packages.



Note By default, installation operations are performed asynchronously: the CLI prompt is returned before the operation is complete, allowing the operator to continue work while the installation is completed in the background. Use the **synchronous** keyword at the end of install commands to delay the return of the CLI prompt until an installation operation is complete. See the *Related Topics* section for more information.

Before you begin

Before upgrading or adding packages, verify that these prerequisites have been met:

- Verify that the ROMMON version is correct. For instructions on upgrading ROM Monitor, see *ROM Monitor Configuration Guide for Cisco CRS Routers*.
- All packages to be upgraded or added are present on a local storage device (for example a flash disk), or a network file server.
- Prerequisites for the activation of packages are met as described in the Prerequisites section.
- Complete the procedures described in the [Preparing for Software Installation Operations, on page 23](#) section.



Note To use the automatic FPD upgrade feature, the **fpd auto-upgrade** command must be enabled in administration configuration mode.

SUMMARY STEPS

1. Connect to the console port and log in.
2. (Optional) **dir flash-disk :**

3. **admin**
4. **install add** [source *source-path* | **tar**] file [activate]
5. (Optional) **show install inactive summary** [**sdr** *sdr-name*]
6. **install activate** {**id** *add-id* | *device package*} [**test**] [**location** *node-id*] [**pause sw-change**] [**sdr** *sdr-name*] [**prompt-level** {**all** | **none**}] [**auto-abort-timer** {*time* | **off**}]
7. Repeat Step 4, on page 32 through Step 6, on page 34 until all packages are activated.
8. (Optional) **show install active summary** [**sdr** *sdr-name*]
9. (Optional) **install verify packages** [**sdr** *sdr-name*]
10. (Optional) **exit**
11. (Optional) **show system verify start**
12. **admin**
13. (Optional) **install commit** [**sdr** *sdr-name*]
14. Upgrade the field-programmable device (FPD) software, if necessary.

DETAILED STEPS

| | Command or Action | Purpose |
|---------------|---|--|
| Step 1 | Connect to the console port and log in. | Establishes a CLI management session with the SDR. Connect to the console port for the active DSC. For more information on console connections, see <i>Cisco IOS XR Getting Started Guide for the Cisco CRS Router</i> . |
| Step 2 | (Optional) dir <i>flash-disk</i> : Example: RP/0/RP0/CPU0:router# dir disk1: | Displays the package files that are available for package upgrades and additions. Note Only PIE files can be added and activated using this procedure. |
| Step 3 | Required: admin Example: RP/0/RP0/CPU0:router# admin | Enters administration EXEC mode. Note Some show install commands can be entered in EXEC mode on an SDR. |
| Step 4 | install add [source <i>source-path</i> tar] file [activate] Example: RP/0/RP0/CPU0:router(admin)# install add disk1:/hfr-mgbl-px.pie-6.0.1 or RP/0/RP0/CPU0:router(admin)# install add source tftp://10.1.1.1/images/ hfr-k9sec-p.pie hfr-mpis-p.pie hfr-mcast-p.pie or RP/0/RP0/CPU0:router(admin)# install add | Unpacks a PIE file from local storage device or network server and adds the package files to the boot device of the router. The boot device is located on the DSC. <ul style="list-style-type: none"> • If the source keyword is used, the <i>source-path</i> specifies the directory path that is used for multiple filenames in the same directory. • If the tar keyword is used, all PIE files contained in the tar file are unpacked. The <i>file</i> argument can take any of these formats: <ul style="list-style-type: none"> • <i>device filename</i> • tftp://hostname_or_ipaddress /directory-path /filename |

| | Command or Action | Purpose |
|----------------------|---|---|
| | <pre>ftp://john:secret@10.1.1.1/images/hfr-k9sec-p.pie</pre> <p>or</p> <pre>RP/0/RP0/CPU0:router(admin)# install add tar rcp://john@10.1.1.1/images/hfr-iosxr-3.6.0.tar</pre> | <ul style="list-style-type: none"> • ftp:// <i>username:password@hostname_or_ipaddress/directory-path/filename</i> • rcp:// <i>username@hostname_or_ipaddress/directory-path/filename</i> <p>These are descriptions for each of the terms used here:</p> <ul style="list-style-type: none"> • <i>device</i>—Name of the local storage device where the PIE file is stored, such as disk1:/. • <i>filename</i>—Name of the PIE file you want to add. If the tar keyword is used, the <i>file</i> argument is the name of a tar file containing one or more PIE files, or directories containing PIE files. • ftpt://—Unpacks the PIE file from a network server using Trivial File Transfer Protocol. • ftp://—Unpacks the PIE file from a network server using File Transfer Protocol. • rcp://—Unpacks the PIE file from a network server using Remote Copy Protocol • <i>hostname_or_ipaddress</i>—Host name or IP address of the network file server. • <i>directory-path</i>—Network file server path that leads to the PIE file to be added. • <i>username</i>—Username of user that has access privileges to the directory in which the PIE file is stored. • <i>password</i>—Password associated with the username of user that has access privileges to the directory in which the PIE file is stored. • activate—Automatically activates the software package after it is successfully added. <p>Note Multiple versions of a software package can be added to the storage device without impacting the running configuration, but only one version of a package can be activated for a card.</p> <p>Tip The automatic FPD upgrade occurs only when the FPD pie is added and activated together with the install PIE.</p> |
| <p>Step 5</p> | <p>(Optional) show install inactive summary [<i>sdr-name</i>]</p> <p>Example:</p> <pre>RP/0/RP0/CPU0:router(admin)# show install inactive summary</pre> | <p>Displays the inactive packages on the router. Verify that the package added in the previous step appears in the display.</p> |

| | Command or Action | Purpose |
|---------------|---|---|
| Step 6 | <p>install activate {<i>id add-id</i> <i>device package</i>} [test] [location <i>node-id</i>] [pause sw-change] [sdr <i>sdr-name</i>] [prompt-level {all none}] [auto-abort-timer {<i>time</i> off}]</p> <p>Example:</p> <pre>RP/0/RP0/CPU0:router(admin)# install activate disk0:hfr-mini-px-4.3.99</pre> | <p>Activates a package that was added to one or more SDRs . (Skip this step if the package was activated earlier with the install add command.)</p> <ul style="list-style-type: none"> • id <i>add-id</i>—Specifies the package using the operation ID of the install add operation in which you added the package. The operation ID is provided in the output of the install add command. You can also use show install log to display installation operation IDs. • device:package—Specifies the package by name. Replace the <i>device:package</i> argument with the name of the boot device and inactive package, which can be displayed as described in the previous step. <p>Note Press ? after a partial package name to display all possible matches available for activation. If there is only one match, press [TAB] to fill in the rest of the package name.</p> <ul style="list-style-type: none"> • sdr <i>sdr-name</i>—Specifies an SDR in administration EXEC mode. This option is not supported in EXEC mode. Replace the <i>sdr-name</i> argument with the name assigned to the SDR. • location <i>node-id</i>—Activates a package for a specific card (node). To display a list of node IDs for the entire system, enter the show platform command in administration EXEC mode. A package cannot be activated on a single node unless some version of the package being activated is already active on all nodes. <p>Note By default, packages are activated for all cards supported by that package.</p> <ul style="list-style-type: none"> • pause sw-change—Pauses the operation after preparatory checks and before the configuration is locked for the actual activation. This action enables you to hold the operation while you perform configuration changes, and proceed with the activation whenever you choose. This operation is useful, for example, if your workflow involves configuring a router out of the network during software installation and you want to minimize the time that the router is out of the network. Follow onscreen instructions to control the pausing and completion of the operation. • prompt-level—Use a prompt-level of all to view all stages of the installation process and to specify whether to continue, or not. • auto-abort-timer—Specifies an abort timer value, in minutes, which when expired loads the last |

| | Command or Action | Purpose |
|---------------|---|---|
| | | <p>committed loadpath. The default is 60. The timer is enabled by default. After the installation, if the activated software is working correctly, use the install commit command to cancel the timer and commit the new loadpath.</p> <p>Note The package being activated must be compatible with the currently active software to operate. When an activation is attempted, the system runs an automatic compatibility check to ensure that the package is compatible with the other active software on the router. The activation is permitted only after all compatibility checks have been passed.</p> <p>Tip When activating packages, use the test option to test the effects of a command without impacting the running system. After the activation process finishes, enter the show install log command to display the process results.</p> <p>Tip The automatic FPD upgrade occurs only when the FPD pie is added and activated together with the install PIE.</p> |
| Step 7 | Repeat Step 4, on page 32 through Step 6, on page 34 until all packages are activated. | Activates additional packages as required. |
| Step 8 | <p>(Optional) show install active summary [sdr sdr-name]</p> <p>Example:</p> <pre>RP/0/RP0/CPU0:router(admin)# show install active</pre> | <p>Displays all active packages. Use this display to determine if the correct packages are active:</p> <ul style="list-style-type: none"> To display the active packages for a specific SDR from administration EXEC mode, use the sdr sdr-name keyword and argument. This option is not supported in EXEC mode. Replace the <i>sdr-name</i> argument with the name assigned to the SDR. |
| Step 9 | <p>(Optional) install verify packages [sdr sdr-name]</p> <p>Example:</p> <pre>RP/0/RP0/CPU0:router(admin)# install verify packages</pre> | <p>Verifies the consistency of a installed software set with the package file from which it originated. This command can be used as a debugging tool to verify the validity of the files that constitute the packages, to determine whether there are any corrupted files. This command also checks for corruptions of installation state files and MBI image files. This command is particularly useful when issued after the activation of a package or upgrading the Cisco IOS XR software to a major release.</p> <p>To perform the command for a specific SDR in administration EXEC mode, use the sdr sdr-name keyword and argument.</p> |

| | Command or Action | Purpose |
|----------------|--|---|
| | | Note The install verify packages command can take up to two minutes for each package to process. |
| Step 10 | (Optional) exit Example: <pre>RP/0/RP0/CPU0:router(admin)# exit</pre> | Exits administration EXEC mode and returns to EXEC mode. Use this command only if you performed the installation operations in administration EXEC mode. |
| Step 11 | (Optional) show system verify start Example: <pre>RP/0/RP0/CPU0:router# show system verify start</pre> | Starts the system status check. |
| Step 12 | admin Example: <pre>RP/0/RP0/CPU0:router# admin</pre> | Enters administration EXEC mode. |
| Step 13 | (Optional) install commit [sdr sdr-name] Example: <pre>RP/0/RP0/CPU0:router# dir disk1: RP/0/RP0/CPU0:router(admin)# install commit</pre> | Commits the current set of packages for an SDR or for all SDRs so that these packages are used if the router is restarted. <ul style="list-style-type: none"> • Enter this command in administration EXEC mode to commit the active software set for all SDRs. • Enter this command in EXEC mode to commit the active software set for the SDR to which you are logged in. • To commit the active software set for a specific SDR from administration EXEC mode, use the sdr sdr-name keyword and argument. For more information, see the <i>Related Topics</i> section. |
| Step 14 | Upgrade the field-programmable device (FPD) software, if necessary. | Whenever a Cisco IOS XR software image that supports SPAs and SIPs is released, a companion SPA or SIP FPD image is bundled with the Cisco IOS XR software release. Generally, the FPD image is not automatically upgraded. You must manually upgrade the FPD image running on the SPA or SIP when you upgrade the Cisco IOS XR software image. FPD versions must be compatible with the Cisco IOS XR software that is running on the router. Note If you have enabled the fpd auto-upgrade command and add and activate the FPD PIE together with the software installation PIE, the FPD image is automatically upgraded before the router is rebooted. |

| | Command or Action | Purpose |
|--|-------------------|--|
| | | For information on FPDs, including instructions to upgrade FPD images, see the <i>Upgrading FPD Cisco IOS XR Software</i> section. |

Related Topics

- [Obtaining and Placing Cisco IOS XR Software](#), on page 21
- [Activation and Deactivation Prerequisites](#), on page 20
- [Preparing for Software Installation Operations](#), on page 23
- [Information About Package Management](#), on page 7
- [Downgrading Packages](#), on page 15
- [PIE Filenames and Version Numbers](#), on page 4
- [Committing the Active Package Set](#), on page 40
- [Prerequisites for ISSU](#)
- [Restrictions for ISSU](#)
- [ISSU Software Images](#)
- [Concurrent Installation Operations in an SDR](#), on page 16

Examples

Adding a Package: Example

The following example shows how to add the contents of a PIE file on disk1: to the boot device. Because the software package is added to the boot device by default, it is not necessary to specify the destination device in the CLI.



Note From Cisco IOS XR Software Release 6.0.1 and later, you must append a forward slash (/) to the source location (for example, **disk1:/**) of the PIE file in the **install add** command.

```
RP/0/RP0/CPU0:router(admin)# install add disk1:/hfr-mpls-px.pie-6.0.1 synchronous

Install operation 4 'install add /disk1:/hfr-mpls.pie-mpls-px.pie-6.0.1 synchronous' started
by user
'cisco' at 18:10:18 UTC Sat Apr 08 2009.
Info:      The following package is now available to be activated:
Info:
Info:      disk0:hfr-mpls-px.pie-6.0.1
Info:
Install operation 4 completed successfully at 18:14:11 UTC Sat Apr 08 2009.
```

The following example shows how to add the contents of a PIE file on a TFTP server to the boot device:

```
RP/0/RP0/CPU0:router(admin)# install add tftp://209.165.201.1/
hfr-mpls.pie synchronous

Install operation 4 '(admin) install add /tftp://209.165.201.1/hfr-mpls.pie synchronous'
```

```

    started by user 'cisco' at 18:16:18 UTC Thu Jan 03 2009.
Info:      The following package is now available to be activated:
Info:
Info:      disk0:hfr-mpls-3.7.2
Info:
Install operation 4 completed successfully at 18:19:10 UTC Thu Jan 03 2009.

```

Activating a Package: Example

The following example shows the activation of the MPLS package. The package is activated on the boot device disk0:

```

RP/0/RP0/CPU0:router(admin)# install activate disk0:
hfr-mpls-3.7.2 synchronous

Install operation 15 'install activate disk0:hfr-mpls-3.7.2 synchronous'
started by user 'lab' at 19:15:33 UTC Sat Apr 08 2009.
Info:      The changes made to software configurations will not be persistent
Info:      across system reloads. Use the command 'admin install commit' to make
Info:      changes persistent.
Info:      Please verify that the system is consistent following the software
Info:      change using the following commands:
Info:      show system verify
Info:      install verify packages
Install operation 5 completed successfully at 19:16:18 UTC Sat Apr 08 2009.

```

Activating a Package by Specifying an Operation ID: Example

The following example shows the activation of the MPLS package using the operation ID of the **install add** operation that added the package:

```

RP/0/RP0/CPU0:router(admin)# install activate id 4

Install operation 5 '(admin) install activate id 4' started by user 'lab' via
CLI at 18:20:17 UTC Thu Jan 03 2009.
Info:      This operation will activate the following package:
Info:      disk0:hfr-mpls-3.7.2
Info:      Install Method: Parallel Process Restart
The install operation will continue asynchronously.
Info:      The changes made to software configurations will not be persistent
Info:      across system reloads. Use the command '(admin) install commit' to
Info:      make changes persistent.
Info:      Please verify that the system is consistent following the software
Info:      change using the following commands:
Info:      show system verify
Info:      install verify packages
Install operation 5 completed successfully at 18:21:30 UTC Thu Jan 03 2009.

```

Adding and Activating a Package from an FTP File Server with One Command: Example

To add and activate a package with a single command, enter the **install add** command with the **activate** keyword. In the following example, the Manageability PIE located on disk1: is verified,

unpacked, and added to the boot device disk0. Because this operation is performed in administration EXEC mode, the package is activated for all SDRs in the system.

```
RP/0/RP0/CPU0:router(admin)# install add disk1:/
hfr-mgbl-px.pie-6.0.1 activate

Install operation 4 'install add /disk1:/hfr-mgbl-px.pie-6.0.1 activate' started
by user 'cisco' at 07:58:56 UTC Wed Mar 01 2009.
The install operation will continue asynchronously.
:router(admin)#Part 1 of 2 (add software): Started
Info:      The following package is now available to be activated:
Info:
Info:      disk0:hfr-mgbl-px.pie-6.0.1
Info:
Part 1 of 2 (add software): Completed successfully
Part 2 of 2 (activate software): Started
Info:      The changes made to software configurations will not be
persistent across system reloads. Use the command 'admin install
Info:      commit' to make changes persistent.
Info:      Please verify that the system is consistent following
the software change using the following commands:
Info:      show system verify
Info:      install verify packages
Part 2 of 2 (activate software): Completed successfully
Part 1 of 2 (add software): Completed successfully
Part 2 of 2 (activate software): Completed successfully
Install operation 4 completed successfully at 08:00:24 UTC Wed Mar 01 2009.
```

Displaying the Active Packages: Example

The following example displays a summary of the active packages on a router. Because this operation is performed in administration EXEC mode, the active packages for all SDRs are displayed.

```
RP/0/RP0/CPU0:router(admin)# show install active summary

Active Packages:
disk0:hfr-mpls-3.7.0
disk0:hfr-mgbl-3.7.0
disk0:hfr-mcast-3.7.0
disk0:hfr-k9sec-3.7.0
disk0:hfr-fpd-3.7.0
disk0:hfr-doc-3.7.0
disk0:hfr-diags-3.7.0
disk0:comp-hfr-mini-3.7.0
```

You can also display the active packages for a specific SDR, or for a specific node. Enter the **show install active** command in EXEC mode, or use the **sdr** keyword in administration EXEC mode, as shown in the following example:

```
RP/0/RP0/CPU0:router(admin)# show install active sdr owner

Secure Domain Router: Owner

Node 0/1/CPU0 [LC] [SDR: Owner]
Boot Device: bootflash:
Boot Image: /disk0/hfr-os-mbi-3.7.0/mbihfr-lc.vm
Committed Packages:
```

```

disk0:hfr-fpd-3.7.0
disk0:hfr-diags-3.7.0
disk0:hfr-mcast-3.7.0
disk0:hfr-mpls-3.7.0
disk0:comp-hfr-mini-3.7.0

Node 0/4/CPU0 [DRP] [SDR: Owner]
Boot Device: disk0:
Boot Image: /disk0/hfr-os-mbi-3.7.0/mbihfr-drp.vm
Committed Packages:
  disk0:hfr-fpd-3.7.0
  disk0:hfr-doc-3.7.0
  disk0:hfr-diags-3.7.0
  disk0:hfr-mgbl-3.7.0
  disk0:hfr-mcast-3.7.0
  disk0:hfr-mpls-3.7.0
  disk0:hfr-k9sec-3.7.0
  disk0:comp-hfr-mini-3.7.0

Node 0/4/CPU1 [DRP] [SDR: Owner]
Boot Device: disk0:
Boot Image: /disk0/hfr-os-mbi-3.7.0/mbihfr-drp.vm
Committed Packages:
  disk0:hfr-fpd-3.7.0
  disk0:hfr-doc-3.7.0
  disk0:hfr-diags-3.7.0
  disk0:hfr-mgbl-3.7.0
  disk0:hfr-mcast-3.7.0
  disk0:hfr-mpls-3.7.0
  disk0:hfr-k9sec-3.7.0
  disk0:comp-hfr-mini-3.7.0

Node 0/RP0/CPU0 [RP] [SDR: Owner]
Boot Device: disk0:
Boot Image: /disk0/hfr-os-mbi-3.7.0/mbihfr-rp.vm
Committed Packages:
  disk0:hfr-fpd-3.7.0
  disk0:hfr-doc-3.7.0
  disk0:hfr-diags-3.7.0
  disk0:hfr-mgbl-3.7.0
  disk0:hfr-mcast-3.7.0
  disk0:hfr-mpls-3.7.0
  disk0:hfr-k9sec-3.7.0
  disk0:comp-hfr-mini-3.7.0

```

Committing the Active Package Set

When a package is activated, it becomes part of the current running configuration. To make the package activation persistent across SDR or system-wide reloads, enter the **install commit** command. On startup, the DSDRSC of the SDR loads this committed software set. If the system is reloaded before the current active software is committed with the **install commit** command, the previously committed software set is used.



Note If the SDR reloads and the committed SDR software is incompatible with the current software running on the rest of the system, the committed software of the SDR will not be used and the current running SDR software is used.

If the system is reloaded before the current active software is committed with the **install commit** command, the previously committed software set is used.



Tip Before committing a package set, verify that the SDR is operating correctly and is forwarding packets as expected.

SUMMARY STEPS

1. **admin**
2. **install commit [sdr sdr-name]**
3. **show install committed [detail | summary | verbose] [location node-id] [sdr sdr-name]**

DETAILED STEPS

| | Command or Action | Purpose |
|---------------|--|---|
| Step 1 | admin Example: RP/0/RP0/CPU0:router# admin | Enters administration EXEC mode. |
| Step 2 | Required: install commit [sdr sdr-name] Example: RP/0/RP0/CPU0:router(admin)# install commit | Commits the current set of packages for an SDR or for all SDRs so that these packages are used if the router is restarted. <ul style="list-style-type: none"> • Enter this command in administration EXEC mode to commit the active software set for all SDRs. • Enter this command in EXEC mode to commit the active software set for the SDR to which you are logged in. • To commit the active software set for a specific SDR from administration EXEC mode, use the sdr sdr-name keyword and argument. |
| Step 3 | show install committed [detail summary verbose] [location node-id] [sdr sdr-name] Example: RP/0/RP0/CPU0:router(admin)# show install committed | Displays which packages are committed. <ul style="list-style-type: none"> • Enter this command in administration EXEC mode to display information for the entire system. Use the sdr sdr-name keyword and argument to display information for a specific SDR. • Enter this command in EXEC mode to display information for a specific SDR only. • For more information on the command options, see <i>System Management Command Reference for isco CRS Routers</i>. |

Examples

Committing the Active Package Set: Example

In the following example, the active software packages are committed on all SDRs in the router :

```
RP/0/RP0/CPU0:router(admin)# install commit

Install operation 16 'install commit' started by user 'lab' at 19:18:58 UTC
Sat Apr 08 2009.
Install operation 16 completed successfully at 19:19:01 UTC Sat Apr 08 2009.
```

Displaying the Committed Package Versions: Example

In the following example, the committed packages are shown for the owner SDR:

```
RP/0/RP0/CPU0:router# show install committed

Secure Domain Router: Owner

Node 0/1/SP [SP] [SDR: Owner]
  Boot Image: /disk0/hfr-os-mpi-3.3.30/sp/mbihfr-sp.vm
  Committed Packages:
    disk0:hfr-diags-3.3.30
    disk0:comp-hfr-mini-3.3.30

Node 0/1/CPU0 [LC] [SDR: Owner]
  Boot Image: /disk0/hfr-os-mpi-3.3.30/lc/mbihfr-lc.vm
  Committed Packages:
    disk0:hfr-diags-3.3.30
    disk0:comp-hfr-mini-3.3.30

Node 0/6/SP [SP] [SDR: Owner]
  Boot Image: /disk0/hfr-os-mpi-3.3.30/sp/mbihfr-sp.vm
  Committed Packages:
    disk0:hfr-diags-3.3.30
    disk0:comp-hfr-mini-3.3.30

Node 0/6/CPU0 [LC] [SDR: Owner]
  Boot Image: /disk0/hfr-os-mpi-3.3.30/lc/mbihfr-lc.vm
  Committed Packages:
--More--
```

As with the **show install active** command, the **show install committed** command may display a composite package that represents all packages in the Cisco IOS XR Unicast Routing Core Bundle.

Upgrading to Cisco IOS XR Software Release 4.0

The main difference between the standard upgrade procedure and the procedure required to upgrade from Release 3.x to 4.x is that the later requires the addition of one additional software package, known as the *upgrade package* (hfr-upgrade-p.pie).

Before you begin

Before performing this procedure, refer to the adding and activating software package procedures described in *System Management Configuration Guide for Cisco CRS Routers*.

SUMMARY STEPS

1. **admin**
2. **install add tftp:// hostname_or_ipaddress / directory-path / mandatory-bundle-pie**
3. **install add tftp:// hostname_or_ipaddress / directory-path / hfr-upgrade-p.pie**
4. **install activate device:mandatory-bundle-pie device:upgrade-package**
5. **install deactivate device:upgrade-package**
6. (Optional) **install commit**
7. **install remove device:upgrade-package**

DETAILED STEPS

| | Command or Action | Purpose |
|---------------|---|---|
| Step 1 | <p>Required: admin</p> <p>Example:</p> <pre>RP/0/RP0/CPU0:router# admin</pre> | <p>Enters administration EXEC mode.</p> <ul style="list-style-type: none"> • From administration EXEC mode, you can perform installation operations for all secure domain routers (SDRs), or for a specific SDR. To enter administration EXEC mode, you must be logged in to the owner SDR and have root-system access privileges. • This command is not required for users entering install commands for a specific SDR. <p>Note Some show install commands can be entered in EXEC mode on an SDR.</p> |
| Step 2 | <p>install add tftp:// hostname_or_ipaddress / directory-path / mandatory-bundle-pie</p> <p>Example:</p> <pre>RP/0/RP0/CPU0:router(admin)# install add tftp://10.1.1.1/auto/tftpboot/usr/400/hfr-mini-p.pie</pre> | <p>Unpacks the mandatory bundle PIE file from a network server and adds the package file to the boot device of the router.</p> <p>Note Refer to the standard procedure to add and activate packages to see other options of PIE file locations and a description of the various arguments for the install add command.</p> |
| Step 3 | <p>install add tftp:// hostname_or_ipaddress / directory-path / hfr-upgrade-p.pie</p> <p>Example:</p> <pre>RP/0/RP0/CPU0:router(admin)# install add tftp://10.1.1.1/auto/tftpboot/usr/400/hfr-upgrade-p.pie</pre> | <p>Unpacks the upgrade PIE file from a network server and adds the package file to the boot device of the router.</p> |
| Step 4 | <p>install activate device:mandatory-bundle-pie device:upgrade-package</p> <p>Example:</p> <pre>RP/0/RP0/CPU0:router(admin)# install activate disk0:hfr-mini-p-4.0.0 disk0:hfr-upgrade-p-4.0.0</pre> | <p>Activates the package that was added to one or more SDRs together with the upgrade package.</p> <p>Note The bundle of mandatory packages and the upgrade bundle are activated together to perform the successful upgrade from release 3.x to 4.x.</p> |

| | Command or Action | Purpose |
|---------------|--|---|
| Step 5 | install deactivate <i>device:upgrade-package</i> Example: RP/0/RP0/CPU0:router(admin)# install deactivate disk0:hfr-upgrade-p-4.0.0 | Deactivates the upgrade package on one or more SDRs . For specific information regarding the deactivation and removal of software packages, refer to the general procedure. |
| Step 6 | (Optional) install commit Example: RP/0/RP0/CPU0:router(admin)# install commit | Commits the current set of packages so that these packages are used if the router is restarted. Packages can be removed only if the deactivation operation is committed. |
| Step 7 | Required: install remove <i>device:upgrade-package</i> Example: RP/0/RP0/CPU0:router(admin)# install remove disk0:hfr-upgrade-p-4.0.0 | Removes the inactive upgrade package. |

Example

The following example illustrates the upgrade operation:

```
RP/0/RP0/CPU0:router(admin)# install add /tftp://223.255.254.254/auto/tftpboot/users/user/hfr-mini-p.pie
```

```
Fri Jul 9 03:53:11.052 UTCRP/0/RP1/CPU0:Jul 9 03:53:12.053 :
instdir[235]: %INSTALL-INSTMGR-6-INSTALL_OPERATION_STARTED :
Install operation 4 '(admin) install add
/tftp://223.255.254.254/auto/tftpboot/users/user/hfr-mini-p.pie'
started by user 'lab'
Install operation 4 '(admin) install add
/tftp://223.255.254.254/auto/tftpboot/users/user/hfr-mini-p.pie'
started by user 'lab' via CLI at 03:53:12 UTC Fri Jul 09 2010.
The install operation will continue asynchronously.
```

```
RP/0/RP0/CPU0:router(admin)#
Info: The following package is now available to be activated:
Info: disk0:hfr-mini-p-4.0.0
Info: The package can be activated across the entire router.
Info: RP/0/RP1/CPU0:Jul 9 04:32:26.152 : instdir[235]:
%INSTALL-INSTMGR-6-INSTALL_OPERATION_COMPLETED_SUCCESSFULLY :
Info: Install operation 4 completed successfully
Info: Install operation 4 completed successfully at 04:32:26 UTC Fri Jul 09 2010.
RP/0/RP0/CPU0:router(admin)# install add /tftp://223.255.254.254/auto/tftpboot/users/user/hfr-mpls-p.pie
```

```
Fri Jul 9 05:07:52.237 UTCRP/0/RP1/CPU0:Jul 9 05:07:53.710 : instdir[235]:
%INSTALL-INSTMGR-6-INSTALL_OPERATION_STARTED :
Info: Install operation 5 '(admin) install add
Info: /tftp://223.255.254.254/auto/tftpboot/users/user/hfr-mpls-p.pie'
Info: started by user 'lab'
Info: Install operation 5 '(admin) install add
Info: /tftp://223.255.254.254/auto/tftpboot/users/user/hfr-mpls-p.pie'
Info: started by user 'lab' via CLI at 05:07:53 UTC Fri Jul 09 2010.
Info: The install operation will continue asynchronously.
RP/0/RP0/CPU0:router(admin)#
```

```

Info: RP/0/RP1/CPU0:Jul 9 05:09:08.854 : instdir[235]:
%INSTALL-INSTMGR-6-INSTALL_OPERATION_COMPLETED_SUCCESSFULLY :
Install operation 5 completed successfully
Info: The following package is now available to be activated:
Info: disk0:hfr-mpls-p-4.0.0
Info: The package can be activated across the entire router.
Info: Install operation 5 completed successfully at 05:09:08 UTC Fri Jul 09 2010.
RP/0/RP0/CPU0:router# install add /tftp://223.255.254.254/auto/tftpboot/users/user/
hfr-upgrade-p.pie

Fri Jul 9 05:10:31.133 UTCRP/0/RP1/CPU0:Jul 9 05:10:32.156 : instdir[235]:
%INSTALL-INSTMGR-6-INSTALL_OPERATION_STARTED :
Info: Install operation 6 '(admin) install add
Info: /tftp://223.255.254.254/auto/tftpboot/users/user/hfr-upgrade-p.pie'
Info: started by user 'lab'
Info: Install operation 6 '(admin) install add
Info: /tftp://223.255.254.254/auto/tftpboot/users/user/hfr-upgrade-p.pie'
Info: started by user 'lab' via CLI at 05:10:32 UTC Fri Jul 09 2010.
Info: The install operation will continue asynchronously.
RP/0/RP0/CPU0:router(admin)#RP/0/RP1/CPU0:
Jul 9 05:11:55.634 : instdir[235]:
%INSTALL-INSTMGR-6-INSTALL_OPERATION_COMPLETED_SUCCESSFULLY :
Info: Install operation 6 completed successfully
Info: The following package is now available to be activated:
Info: disk0:hfr-upgrade-p-4.0.0
Info: The package can be activated across the entire router.
Info: Install operation 6 completed successfully at 05:11:55 UTC Fri Jul 09 2010.
RP/0/RP0/CPU0:router(admin)# install activate disk0:hfr-mini-p-4.0.0 disk0:hfr-upgrade-p-4.0.0
disk0:hfr-mpls-p-4.0.0

Fri Jul 9 05:23:23.150 UTC
Install operation 7 '(admin) install activate disk0:hfr-mini-p-4.0.0
Info: disk0:hfr-upgrade-p-4.0.0 disk0:hfr-mpls-p-4.0.0'
Info: started by user 'lab'RP/0/RP1/CPU0:Jul 9 05:23:24.161 : instdir[235]:
%INSTALL-INSTMGR-6-INSTALL_OPERATION_STARTED :
Info: Install operation 7 '(admin) install activate disk0:hfr-mini-p-4.0.0
Info: disk0:hfr-upgrade-p-4.0.0 disk0:hfr-mpls-p-4.0.0'
Info: started by user 'lab' via CLI at 05:23:24 UTC Fri Jul 09 2010.\ 1% complete:
Info: The operation can still be aborted (ctrl-c for options)
Info: This operation will reload the following nodes in parallel:
Info: 0/RP1/CPU0 (HRP) (SDR: Owner)
Info: 0/SM0/SP (Fabric-SP) (Admin Resource)Proceed with this install operation (y/n)?
[y]
Info: 1% complete: The operation can still be aborted (ctrl-c for options)
Info: Install Method: Parallel Reload/ 1% complete: The operation can still be aborted
(ctrl-c for options)
Info: The install operation will continue asynchronously.
RP/0/RP0/CPU0:router(admin)#SP/0/SM0/SP:
Jul 9 05:36:41.152 : insthelper[62]: %INSTALL-INSTHELPER-6-RELOAD_NODE_INFO :
Info: As part of install operation 7 this node (0/SM0/SP) will now reload.
Info: The changes made to software configurations will not be persistent
Info: across system reloads. Use the command '(admin) install commit' to
Info: make changes persistent.
Info: Please verify that the system is consistent following the software
RP/0/RP1/CPU0:Jul 9 05:36:43.962 : instdir[235]:
%INSTALL-INSTMGR-6-INSTALL_OPERATION_COMPLETED_SUCCESSFULLY :
Info: Install operation 7 completed successfully
Info: change using the following commands:
Info: show system verify
Info: install verify packages
Info: Install operation 7 completed successfully at 05:36:43 UTC Fri Jul 09 2010.
rebooting .....Initializing DDR SDRAM...found 4096 MB
Initializing ECC on bank 0Initializing ECC on bank 1
Initializing ECC on bank 2

```

```

Initializing ECC on bank 3
Turning off data cache, using DDR for first time
Initializing NVRAM...Testing a portion of DDR SDRAM ...done
Reading ID EEPROMs .....
Initializing SQUID ...
Initializing PCI ...PCI0 device[1]: Vendor ID 0x10eePCI0 device[1]: Device ID 0x300ePCI1
device[1]:
Device ID 0x1100PCI1 device[1]: Vendor ID 0x1013PCI1 device[2]: Device ID 0x680PCI1 device[2]:
Vendor ID 0x1095PCI1 device[3]: Device ID 0x5618PCI1 device[3]: Vendor ID 0x14e4Configuring
MPPs ...
Configuring PCMCIA slots ...System Bootstrap, Version 1.53(20090311:225342) [CRS-1 ROMMON],

Copyright (c) 1994-2009 by Cisco Systems, Inc.
Acquiring backplane mastership ... successful
Preparing for fan initialization..... ready
Setting fan speed to 4000 RPMs successfulReading backplane EEPROM ...
Released backplane mastership ...Board type is 0x100002 (1048578)
Switch 0 initialized
Switch 0 Port fe1: link up (100Mb Full Duplex Copper)
Enabling watchdogG4(7457-NonSMP-MV64360 Rev 3) platform with 4096 MB of main memory....

CARD_RACK_NUMBER: 0    CARD_SLOT_NUMBER: 1    CPU_INSTANCE: 1
RACK_SERIAL_NUMBER: TBC08052402
MBI Validation starts ... using Control Plane Ethernet.
DEBUG : Driving up signal strength for Intel LXT971
Our MAC address is 0005.9a3e.89da
Interface link changed state to UP.
Interface link state up.
MBI validation sending request.
HIT CTRL-C to abort
MBI validation sending request.
HIT CTRL-C to abort
MBI validation sending request.
HIT CTRL-C to abort
MBI validation sending request.
HIT CTRL-C to abort
MBI validation sending request.
HIT CTRL-C to abort
No MBI confirmation received from dSCboot: booting from
bootflash:disk0/hfr-os-mpi-4.0.0/mbihfr-rp.vm
.....
#####

Restricted Rights LegendUse, duplication, or disclosure by the Government is
subject to restrictions as set forth in subparagraph(c) of the Commercial Computer Software
- Restricted
Rights clause at FAR sec. 52.227-19 and subparagraph(c) (1) (ii) of the Rights in Technical
Data and Computer
Software clause at DFARS sec. 252.227-7013.
cisco Systems, Inc.
170 West Tasman Drive
San Jose, California 95134-1706
Cisco IOS XR Software for the Cisco XR Router, Version 4.0.0 Copyright (c) 2010 by Cisco
Systems, Inc.
Jul 09 05:39:21.334 : Install (Node Preparation): Booting with software activated by previous
install
operation,errno=2
RP/0/RP1/CPU0:Jul 9 05:44:45.941: syslogd_helper: [89]: dsc_event_handler: Got SysMgr dSC
event : 1
RP/0/RP1/CPU0:Jul 9 05:45:11.354 : shelfmgr[306]: %PLATFORM-SHELFMGR-3-POWERDOWN_RESET :
Node 0/2/SP is powered off due to admin power off request ios con0/RP1/CPU0 is now available
Press RETURN to get started.
RP/0/RP1/CPU0:Jul 9 05:45:27.453 : instdir[216]:

```

```
%INSTALL-INSTMGR-4-ACTIVE_SOFTWARE_COMMITTED_INFO :
The currently active software is not committed. If the system reboots then the committed
software will be used.
Use 'install commit' to commit the active software. SYSTEM CONFIGURATION IN PROCESS
The startup configuration for this device is presently loading.
This may take a few minutes. You will be notified upon completion.
Please do not attempt to reconfigure the device until this process is complete.
User Access VerificationUsername: labPassword:
RP/0/RP0/CPU0:router# admin
Fri Jul 9 05:45:55.941 UTC
RP/0/RP0/CPU0:router(admin)# show platform
```

```
Fri Jul 9 05:45:59.805 UTCNode          Type          PLIM          State
Config State
-----
0/2/SP          MSC(SP)       N/A           UNPOWERED     NPWR, NSHUT, MON
0/RP1/CPU0     RP(Active)    N/A           IOS XR RUN    PWR, NSHUT, MON
0/SM0/SP       FC-40G/S(SP) N/A           MBI-RUNNING   PWR, NSHUT, MON
0/SM1/*        UNKNOWN      N/A           PRESENT       PWR, NSHUT, MON
```

```
RP/0/RP1/CPU0:ios(admin)#
RP/0/RP1/CPU0:Jul 9 05:46:08.411 : instdir_lr[217]:
%INSTALL-INSTMGR-4-ACTIVE_SOFTWARE_COMMITTED_INFO :
The currently active software is not committed. If the system reboots then the committed
software will be used.
Use 'install commit' to commit the active software.
RP/0/RP1/CPU0:Jul 9 05:50:40.918 : placed[283]: LR-PLANE-READY DECLARATIONSYSTEM
CONFIGURATION COMPLETED
RP/0/RP1/CPU0:Jul 9 05:50:57.293 : ifmgr[213]: %PKT_INFRA-LINK-3-UPDOWN :
Interface MgmtEth0/RP1/CPU0/0, changed state to Down
RP/0/RP1/CPU0:Jul 9 05:50:57.313 : ifmgr[213]: %PKT_INFRA-LINK-3-UPDOWN :
Interface MgmtEth0/RP1/CPU0/0, changed state to Up
RP/0/RP0/CPU0:router(admin)# show platform
```

```
Fri Jul 9 05:59:36.266 UTC
Node          Type          PLIM          State          Config State
-----
0/2/SP          MSC(SP)       N/A           UNPOWERED     NPWR, NSHUT, MON
0/RP1/CPU0     RP(Active)    N/A           IOS XR RUN    PWR, NSHUT, MON
0/SM0/SP       FC-40G/S(SP) N/A           IOS XR RUN    PWR, NSHUT, MON
0/SM1/*        UNKNOWN      N/A           PRESENT       PWR, NSHUT, MON
```

```
RP/0/RP0/CPU0:router(admin)# install commit
```

```
Fri Jul 9 05:59:41.851 UTC
Install operation 8 '(admin) install commit' started by user 'lab' via CLI at
05:59:43 UTC Fri Jul 09 2010./
20% complete: The operation can no longer be aborted (ctrl-c for options)-
20% complete: The operation can no longer be aborted (ctrl-c for options)\
100% complete:
The operation can no longer be aborted (ctrl-c for options)
RP/0/RP1/CPU0:Jul 9 05:59:46.402 : instdir[216]:
%INSTALL-INSTMGR-4-ACTIVE_SOFTWARE_COMMITTED_INFO :
The currently active software is now the same as the committed software.
Install operation 8 completed successfully at 05:59:46 UTC Fri Jul 09 2010.
RP/0/RP0/CPU0:router(admin)# install deactivate disk0:
hfr-upgrade-p-4.0.0
```

```
Fri Jul 9 05:59:58.082 UTC
Install operation 9 '(admin) install deactivate disk0:hfr-upgrade-p-4.0.0' started
by user 'lab' via CLI at 05:59:59 UTC
Fri Jul 09 2010.
1% complete: The operation can still be aborted (ctrl-c for options)-
1% complete: The operation can still be aborted (ctrl-c for options)
```

```

Info:      Install Method: Parallel Process Restart\
1% complete: The operation can still be aborted (ctrl-c for options)
The install operation will continue asynchronously.
RP/0/RP0/CPU0:router(admin)#
Info:      The changes made to software configurations will not be persistent
Info:      across system reloads. Use the command '(admin) install commit' to
Info:      make changes persistent.
Info:      Please verify that the system is consistent following the software
Info:      change using the following commands:
Info:      show system verify
Info:      install verify packages
RP/0/RP1/CPU0:Jul  9 06:01:45.662 : instdir[216]:
%INSTALL-INSTMGR-4-ACTIVE_SOFTWARE_COMMITTED_INFO :
The currently active software is not committed. If the system reboots then the committed
software will be used.
Use 'install commit' to commit the active software.
Install operation 9 completed successfully at 06:01:45 UTC Fri Jul 09 2010.
RP/0/RP0/CPU0:router(admin)# install commit

Fri Jul  9 06:01:53.583 UTC
Install operation 10 '(admin) install commit' started by user 'lab' via CLI at06:01:54 UTC
  Fri Jul 09 2010./
20% complete: The operation can no longer be aborted (ctrl-c for options)-
20% complete: The operation can no longer be aborted (ctrl-c for options)\
100% complete: The operation can no longer be aborted (ctrl-c for options)
RP/0/RP1/CPU0:Jul  9 06:01:57.807 : instdir[216]:
%INSTALL-INSTMGR-4-ACTIVE_SOFTWARE_COMMITTED_INFO :
The currently active software is now the same as the committed software.
Install operation 10 completed successfully at 06:01:57 UTC Fri Jul 09 2010.
RP/0/RP0/CPU0:router(admin)#
RP/0/RP0/CPU0:router(admin)#
RP/0/RP0/CPU0:router(admin)# install remove disk0:
hfr-upgrade-p-4.0.0

Fri Jul  9 06:04:57.676 UTC
Install operation 11 '(admin) install remove disk0:hfr-upgrade-p-4.0.0' started
  by user 'lab' via CLI at 06:04:58 UTC
  Fri Jul 09 2010./
1% complete: The operation can no longer be aborted (ctrl-c for options)
Info:      This operation will remove the following packages:
Info:      disk0:hfr-fpd-4.0.0
Info:      disk0:hfr-doc-4.0.0
Info:      disk0:hfr-k9sec-4.0.0
Info:      disk0:hfr-sbc-4.0.0
Info:      disk0:hfr-diags-4.0.0
Info:      disk0:hfr-mgbl-4.0.0
Info:      disk0:hfr-mcast-4.0.0
Info:      disk0:hfr-mppls-4.0.0
Info:      disk0:hfr-rout-4.0.0
Info:      disk0:hfr-fwgd-4.0.0
Info:      disk0:hfr-lc-4.0.0
Info:      disk0:hfr-admin-4.0.0
Info:      disk0:hfr-upgrade-p-4.0.0-
1% complete: The operation can no longer be aborted (ctrl-c for options)
Info:      After this install remove the following install rollback point will
Info:      no longer be reachable, as the required packages will not be present:
Info:      7\
1% complete: The operation can no longer be aborted (ctrl-c for options)
Proceed with removing these packages? [confirm]
1% complete: The operation can no longer be aborted (ctrl-c for options)
The install operation will continue asynchronously.
RP/0/RP0/CPU0:router(admin)#SP/0/SMO/SP:Jul
  9 06:05:03.902 : envmon[117]: %PLATFORM-ENVMON-4-ALARM : MINOR_HI alarm
cleared by host__temp__Inlet0

```



```

Install operation 11 completed successfully at 06:05:33 UTC
Fri Jul 09 2010.
RP/0/RP0/CPU0:router(admin)#
RP/0/RP0/CPU0:router(admin)# show install act
Fri Jul 9 06:08:11.372 UTC
Secure Domain Router: Owner Node 0/RP1/CPU0 [HRP] [SDR: Owner]
Boot Device: disk0:      Boot Image: /disk0/hfr-os-mpi-4.0.0/mbihfr-rp.vm
Active Packages:      disk0:hfr-mpis-p-4.0.0      disk0:hfr-mini-p-4.0.0
Admin Resources: Node 0/SM0/SP [Fabric-SP] [Admin Resource]
Boot Device: bootflash:  Boot Image: /disk0/hfr-os-mpi-4.0.0/sp/mbihfr-sp.vm
Active Packages:      disk0:hfr-mini-p-4.0.0
RP/0/RP0/CPU0:router(admin)#

```

Related Topics

[Activation and Deactivation Prerequisites](#), on page 20

[Adding and Activating Packages](#), on page 31

[Deactivating and Removing Cisco IOS XR Software Packages](#), on page 49

Deactivating and Removing Cisco IOS XR Software Packages

When a package is deactivated, it is no longer active on the SDR, but the package files remain on the boot disk. The package files can be reactivated later, or they can be removed from the disk.

A package is deactivated using the following methods:

- When a newer version of a package is activated, the earlier version of the package is automatically deactivated. See *Related Topics* for more information.



Note Activating a software maintenance upgrade (SMU) does not cause any earlier SMUs or the package to which the SMU applies to be automatically deactivated.

- When an earlier version of a package is activated, the newer version is deactivated automatically. See *Related Topics* for more information.
- A specific package is deactivated using the **install deactivate** command. This command turns off the package features for a card or card type.

Before you begin

The following are the restrictions when deactivating and removing Cisco IOS XR Software packages:

- If a package is added to all SDRs by the admin user, an SDR user cannot remove the package.
- If a package is added to a specific SDR by an admin user or SDR user, an SDR user can remove the package.
- A package cannot be deleted if it is part of the running or committed software of the SDR.
- A package cannot be deactivated if that package is required by another active package. When a deactivation is attempted, the system runs an automatic check to ensure that the package is not required by other active packages. The deactivation is permitted only after all compatibility checks have been passed.
- Router reloads: If the deactivation requires a router reload, a confirmation prompt appears. Use the **install deactivate** command with the **prompt-level none** keywords to automatically ignore any reload confirmation prompts and proceed with the package deactivation. The router reloads if required.

- Node reloads: If a software operation requires a node reload, the configuration register for that node should be set to autoboot. If the config-register for the node is not set to autoboot, then the system automatically changes the setting and the node reloads. A message describing the change is displayed.
- FPD versions must be compatible with the Cisco IOS XR software that is running on the router; if an incompatibility exists between an FPD version and the Cisco IOS XR software, the device with the field-programmable gate array (FPGA) may not operate properly until the incompatibility is resolved. For information on FPDs, including instructions to upgrade FPD images, see the *Upgrading FPD Cisco IOS XR Software* module of *Interface and Hardware Component Configuration Guide for Cisco CRS Routers*.

SUMMARY STEPS

1. Connect to the console port and log in.
2. **admin**
3. **install deactivate** { **id** *add-id* | *device : package* } [**location** *node-id*] [**test**] [**pause sw-change**] [**sdr** *sdr-name*]
4. (Optional) **show install inactive summary** [**sdr** *sdr-name*]
5. (Optional) **install verify packages** [**sdr** *sdr-name*]
6. **exit**
7. (Optional) **show system verify start**
8. (Optional) **show system verify** [**detail** | **report**]
9. **admin**
10. (Optional) **install commit**
11. (Optional) **install remove** { **id** *add-id* | *device : package* | **inactive** } [**test**]

DETAILED STEPS

| | Command or Action | Purpose |
|---------------|--|--|
| Step 1 | Connect to the console port and log in. | Establishes a CLI management session with the SDR. <ul style="list-style-type: none"> • To log in to a specific SDR, connect to the console port of the active DSDRSC. • To perform installation operations in administration EXEC mode, connect to the console port for the active DSC (active DSDRSC for the owner SDR). For more information on console connections, see <i>Cisco IOS XR Getting Started Guide for the Cisco CRS Router</i> . |
| Step 2 | Required: admin Example: RP/0/RP0/CPU0:router# admin | Enters administration EXEC mode. <ul style="list-style-type: none"> • From administration EXEC mode, you can perform installation operations for all SDRs, or for a specific SDR. To enter administration EXEC mode, you must be logged in to the owner SDR and have root-system access privileges. • This command is not required for users entering install CLIs for a specific SDR. |

| | Command or Action | Purpose |
|--------|--|---|
| Step 3 | <p>install deactivate { id <i>add-id</i> <i>device : package</i> } [location <i>node-id</i>] [test] [pause sw-change] [sdr <i>sdr-name</i>]</p> <p>Example:</p> <pre>RP/0/RP0/CPU0:router(admin)# install deactivate disk0:hfr-diags-3.8.30</pre> | <p>Deactivates a package on one or more SDRs .</p> <ul style="list-style-type: none"> To deactivate all packages that were added in one or more specific install add operations, or specify packages by name, use the id <i>add-id</i> keyword and argument. The operation ID of an install add operation is indicated in the syslog displayed during the operation and in the output of the show install log command. To deactivate a package for all SDRs in the system , use this command in administration EXEC mode. To deactivate a package for a specific SDR from administration EXEC mode, use the sdr <i>sdr-name</i> keyword and argument. To deactivate a package when logged in to an SDR, use this command in EXEC mode. Use the location <i>node-id</i> keyword and argument to deactivate the package for a specific node, if supported. Use the pause sw-change keywords to pause the operation after preparatory checks and before the configuration is locked for the actual deactivation. This enables you to hold the operation while you perform configuration changes, and proceed with the deactivation whenever you choose. This is useful, for example, if your workflow involves configuring a router out of the network during software changes and you want to minimize the time that the router is out of the network. Follow the onscreen instructions to control the pausing and completion of the operation. <p>Note Press ? after a partial package name to display all possible matches available for deactivation. If there is only one match, press [TAB] to fill in the rest of the package name.</p> <p>When a package is deactivated for an SDR from administration EXEC mode, a notification message appears on the console for that SDR, with information on the impact of the deactivation.</p> |
| Step 4 | <p>(Optional) show install inactive summary [sdr <i>sdr-name</i>]</p> <p>Example:</p> | <p>Displays the inactive packages on the router.</p> <p>To display the inactive packages for a specific SDR from administration EXEC mode, use the sdr <i>sdr-name</i></p> |

| | Command or Action | Purpose |
|---------------|--|---|
| | RP/0/RP0/CPU0:router(admin)# show install inactive summary | keyword and argument. This option is not supported in EXEC mode. Replace <i>sdr-name</i> with the name assigned to the SDR. |
| Step 5 | <p>(Optional) install verify packages [sdr <i>sdr-name</i>]</p> <p>Example:</p> <pre>RP/0/RP0/CPU0:router(admin)# install verify packages</pre> | <p>Verifies the consistency of an installed software set with the package file from which it originated. This command can be used as a debugging tool to verify the validity of the files that constitute the packages, to determine if there are any corrupted files. This command also checks for corruptions of installation state files and MBI image files. This command is particularly useful when issued after the activation of a package or upgrading the Cisco IOS XR software to a major release.</p> <p>To perform the command for an SDR, use the install verify packages command with the sdr <i>sdr-name</i> keyword and argument.</p> <p>Note The install verify packages command can take up to two minutes per package to process.</p> |
| Step 6 | <p>Required: exit</p> <p>Example:</p> <pre>RP/0/RP0/CPU0:router(admin)# exit</pre> | <p>Exits administration EXEC mode and returns to EXEC mode.</p> <p>Use this command only if you performed the installation operations in administration EXEC mode.</p> |
| Step 7 | <p>(Optional) show system verify start</p> <p>Example:</p> <pre>RP/0/RP0/CPU0:router# show system verify start</pre> | Starts the system status check. |
| Step 8 | <p>(Optional) show system verify [detail report]</p> <p>Example:</p> <pre>RP/0/RP0/CPU0:router# show system verify</pre> | <p>Displays system status information. A variety of information is displayed including the memory and CPU usage, process status, protocol status, and other status information. Use this information to verify that the system is stable.</p> <p>Enter this command in EXEC mode for each SDR impacted by the installation operation.</p> <ul style="list-style-type: none"> • detail—Displays additional information at the card and processor level, including actual numbers. • report—Displays the same information as the default show system verify command |

| | Command or Action | Purpose |
|----------------|---|--|
| | | <p>Note Although most of the output should display the status “OK,” some processes may show other output, such as “Warning.” This does not specifically indicate a problem. Contact your Cisco technical support representative for more information on the output of this command.</p> |
| Step 9 | <p>admin</p> <p>Example:</p> <pre>RP/0/RP0/CPU0:router# admin</pre> | Enters administration EXEC mode. |
| Step 10 | <p>(Optional) install commit</p> <p>Example:</p> <pre>RP/0/RP0/CPU0:router(admin)# install commit</pre> | <p>Commits the current set of packages so that these packages are used if the router is restarted. Packages can be removed only if the deactivation operation is committed.</p> <p>Note This command is entered in administration EXEC or EXEC mode.</p> |
| Step 11 | <p>(Optional) install remove { id <i>add-id</i> device : <i>package</i> inactive } [test]</p> <p>Example:</p> <pre>RP/0/RP0/CPU0:router(admin)# install remove disk0:hfr-diags-3.8.30</pre> | <p>Removes the inactive package.</p> <ul style="list-style-type: none"> • Only inactive packages can be removed. • Packages can be removed only if they are deactivated from all cards in all SDRs . • The package deactivation must be committed. • To remove a specific inactive package from a storage device, use the install remove command with the <i>device: package</i> arguments. • To remove all packages that were added in one or more specific install add operations, use the id <i>add-id</i> keyword and argument. The operation ID of an install add operation is indicated in the syslog displayed during the operation and in the output of the show install log command. If you specify packages according to operation ID, all the packages that were added by the specified operation must still be on the router. • To remove all inactive packages from all nodes in the system or SDR, use the install remove command with the inactive keyword. • To remove packages from all SDRs, use the install remove command in administration EXEC mode. • To remove packages from a specific SDR, use the install remove command in EXEC mode. |

Related Topics

[Adding and Activating Packages](#), on page 31

[Committing the Active Package Set](#), on page 40

Examples

In the following examples, a package is deactivated from all SDRs in a router. The changes are committed and the inactive package is removed from the router.

Deactivating the Package: Example

```
RP/0/RP0/CPU0:router(admin)# install deactivate disk0:hfr
-diags-.7.2
```

```
Install operation 27 'install deactivate disk0:hfr-diags-3.7.2' started by
user 'lab' at 23:29:37 UTC Sat Apr 15 2009.
The install operation will continue asynchronously.
Info:      The changes made to software configuration
Info:      across system reloads. Use the command 'admin install commit' to make
Info:      changes persistent.
Info:      Please verify that the system is consistent following the software
Info:      change using the following commands:
Info:      show system verify
Info:      install verify packages
Install operation 27 completed successfully at 23:30:22 UTC Sat Apr 15 2009.
```

Committing the Active Software Set: Example

```
RP/0/RP0/CPU0:router(admin)# install commit
```

```
Install operation 29 'install commit' started by user 'lab' at 23:39:21 UTC
Sat Apr 15 2009.
Install operation 29 completed successfully at 23:39:24 UTC Sat Apr 15 2009.
```

Displaying the Inactive Packages: Example

```
RP/0/RP0/CPU0:router(admin)# show install inactive summary
```

```
Default Profile:
  SDRs:
  Owner
  Inactive Packages:
    disk0:hfr-diags-3.7.2
```

Removing the Inactive Package from the Router: Example

The following example shows how to remove an inactive package. In this example, the operation is run in test mode. The operation is confirmed and the package is removed.

```
RP/0/RP0/CPU0:router(admin)# install remove disk0:hfr-diags-3.7.2 test
```

```
Install operation 30 'install remove disk0:hfr-diags-3.7.2 test' started by
user 'lab' at 23:40:22 UTC Sat Apr 15 2009.
Warning: No changes will occur due to 'test' option being specified. The
Warning: following is the predicted output for this install command.
Info:      This operation will remove the following package:
```

```

Info:          disk0:hfr-diags-3.7.2
Info:          After this install remove the following install rollback points will
Info:          no longer be reachable, as the required packages will not be present:
Info:          4, 9, 10, 14, 15, 17, 18
Proceed with removing these packages? [confirm] y

The install operation will continue asynchronously.
Install operation 30 completed successfully at 23.

```

Pausing Before Configuration Lock: Example

The following example shows how to deactivate a package, pausing the operation before locking the configuration for the actual software deactivation. While the operation is paused, you can enter a configuration mode and perform configurations. When you want to complete the operation, enter the **install operation id complete** command, or the **install operation id attach synchronous** command.

```

RP/0/RP0/CPU0:router(admin)# install deactivate disk0:comp-hfr
-3.7.2.07I.CSCsr09575-1.0.0 pause sw-change

Install operation 12 '(admin) install deactivate
  disk0:comp-hfr-3.7.2.07I.CSCsr09575-1.0.0 pause sw-change'
  started by user 'admin' via CLI at 09:06:26 BST Mon Jul 07 2009.
Info: This operation will reload the following nodes in parallel:
Info: 0/0/CPU0 (RP) (SDR: Owner)
Info: 0/1/CPU0 (LC (E3-GE-4)) (SDR: Owner)
Info: 0/5/CPU0 (LC (E3-OC3-POS-4)) (SDR: Owner)
Proceed with this install operation (y/n)? [y]
The install operation will continue asynchronously.
Info: Install Method: Parallel Reload
Info: Install operation 12 is pausing before the config lock is applied for
Info:       the software change as requested by the user.
Info: No further install operations will be allowed until the operation is resumed.
Info: Please continue the operation using one of the following steps:
Info: - run the command '(admin) install operation 12 complete'.
Info: - run the command '(admin) install operation 12 attach synchronous' and then
Info:       answer the query.

```

Rolling Back to a Previous Software Set

Cisco IOS XR software allows you to roll back one or more SDRs to a previous committed or uncommitted software set. Use the **show install rollback ?** command to view the available rollback points and use the **install rollback to** command to roll back the SDR to a previous software set. You can also use the **install rollback to committed** command to roll back to the most recent committed software set.



Note Rollback operations can be performed for all SDRs by running the command in administration EXEC or for a single SDR by running the command in either administration EXEC or EXEC mode.

Displaying Rollback Points

A rollback point is created every time a software package is activated, deactivated, or committed. Use the **show install rollback ?** command to display the eligible rollback points.

```
RP/0/RP0/CPU0:router# admin
RP/0/RP0/CPU0:router(admin)# show install rollback ?

  0  ID of the rollback point to show package information for
  2  ID of the rollback point to show package information for
```

In this example, the rollback points are 0 and 2. The rollback point with the highest number is the current software point. For example, if the last installation operation was operation 3 (activating the MPLS package) then the highest rollback point is 3, which is the same as the current software (MPLS package activated).

To easily identify specific rollback points, you can assign a label or description to a rollback point using the **install label** command.

Enter the command in administration EXEC mode to display rollback points for all SDRs. Enter the command in EXEC mode to display rollback points for the SDR to which you are currently logged in. You can also display rollback points for a specific SDR in administration EXEC mode by using the **sdm sdr-name** keyword and argument.

Displaying the Active Packages Associated with a Rollback Point

To display the active packages associated with a rollback point, use the **show install rollback** command with the *point-id* argument. This command displays the packages that are active if you roll back one or more SDRs to that installation point. For example, the **show install rollback 2** command displays the packages that are active if you roll back to rollback point 2.

```
RP/0/RP0/CPU0:router(admin)# show install rollback 2

Secure Domain Router: Owner

Node 0/1/SP [SP] [SDR: Owner]
  Boot Image: /disk0/hfr-os-mbi-3.8.84/sp/mbihfr-sp.vm
  Rollback Packages:
    disk0:hfr-diags-3.8.84
    disk0:comp-hfr-mini-3.8.84

Node 0/1/CPU0 [LC] [SDR: Owner]
  Boot Image: /disk0/hfr-os-mbi-3.8.84/lc/mbihfr-lc.vm
  Rollback Packages:
    disk0:hfr-diags-3.8.84
    disk0:comp-hfr-mini-3.8.84

Node 0/RP0/CPU0 [RP] [SDR: Owner]
  Boot Image: /disk0/hfr-os-mbi-3.8.84/mbihfr-rp.vm
  Rollback Packages:
    disk0:hfr-diags-3.8.84
    disk0:hfr-mgbl-3.8.84
    disk0:hfr-k9sec-3.8.84
    disk0:comp-hfr-mini-3.8.84

Node 0/RP1/CPU0 [RP] [SDR: Owner]
  Boot Image: /disk0/hfr-os-mbi-3.8.84/mbihfr-rp.vm
  Rollback Packages:
    disk0:hfr-diags-3.8.84
    disk0:hfr-mgbl-3.8.84
    disk0:hfr-k9sec-3.8.84
    disk0:comp-hfr-mini-3.8.84
```



```

Node 0/SM0/SP [SP] [SDR: Owner]
  Boot Image: /disk0/hfr-os-mbi-3.8.84/sp/mbihfr-sp.vm
  Rollback Packages:
    disk0:hfr-diags-3.8.84
    disk0:comp-hfr-mini-3.8.84
Node 0/SM1/SP [SP] [SDR: Owner]
  Boot Image: /disk0/hfr-os-mbi-3.8.84/sp/mbihfr-sp.vm
  Rollback Packages:
    disk0:hfr-diags-3.8.84
    disk0:comp-hfr-mini-3.8.84

Node 0/SM2/SP [SP] [SDR: Owner]
  Boot Image: /disk0/hfr-os-mbi-3.8.84/sp/mbihfr-sp.vm
  Rollback Packages:
    disk0:hfr-diags-3.8.84
    disk0:comp-hfr-mini-3.8.84

Node 0/SM3/SP [SP] [SDR: Owner]
  Boot Image: /disk0/hfr-os-mbi-3.8.84/sp/mbihfr-sp.vm
  Rollback Packages:
    disk0:hfr-diags-3.8.84
    disk0:comp-hfr-mini-3.8.84

```

Enter the command in administration EXEC mode to view the rollback points for all SDRs. Enter the command in EXEC mode to display the rollback points for the SDR to which you are currently logged in. You can also display rollback points for a specific SDR in administration EXEC mode by using the **sdr** *sdr-name* keyword and argument.



Note For more information on the command options, see the *Software Package Management Commands on Cisco IOS XR Software* module of *System Management Command Reference for isco CRS Routers*.

Rolling Back to a Specific Rollback Point

You can roll back to a specific rollback point, including a noncommitted software set:

- If you roll back to the most recent noncommitted rollback point (with the highest number), you do not need to reload the router.
- You can repeat the rollback process one rollback point at a time without reloading if you always choose the most recent rollback point.
- If you choose a rollback point that is older than the most recent point, the impacted nodes reload, interrupting data traffic on those nodes. Before the reload occurs, you are prompted to confirm the install rollback operation.

In the following example, the system is rolled back to noncommitted rollback point 8:

```

RP/0/RP0/CPU0:router(admin)# install rollback to 8

Install operation 10 'install rollback to 8' started by user 'cisco' at 07:49:26
UTC Mon Nov 14 2009.
The install operation will continue asynchronously.
Info:      The changes made to software configurations will not be persistent
Info:      across system reloads. Use the command 'admin install commit' to make
Info:      changes persistent.
Info:      Please verify that the system is consistent following the software
Info:      change using the following commands:

```

```
Info:          show system verify
Info:          install verify packages
```

The currently active software is the same as the committed software.

Install operation 10 completed successfully at 07:51:24 UTC Mon Nov 14 2009.

Rolling Back to the Last Committed Package Set

Use the **install rollback to committed** command to roll back to the last committed package set.

In the following example, all SDRs in the system are rolled back to the last committed package set :

```
RP/0/RP0/CPU0:router(admin)# install rollback to committed

Install operation 27 'install rollback to committed' started by user 'lab' at
16:41:38 UTC Sat Nov 19 2009.
Info:      The rollback to committed software will require a reload of impacted
Info:      nodes because it is over multiple activation & deactivation
Info:      operations.
Info:      This operation will reload the following node:
Info:      0/RP1/CPU0 (RP) (SDR: Owner)
Info:      This operation will reload all RPs in the Owner SDR, and thereby
Info:      indirectly cause every node in the router to reload.

Proceed with this install operation? [confirm]

Updating Commit Database. Please wait...[OK]
Info:      The changes made to software configurations will not be persistent
Info:      across system reloads. Use the command 'admin install commit' to make
Info:      changes persistent.
Info:      Please verify that the system is consistent following the software
Info:      change using the following commands:
Info:      show system verify
Info:      install verify packages
Install operation 27 completed successfully at 16:42:23 UTC Sat Nov 19 2009.
```

Enter the command in administration EXEC mode to perform a rollback for all SDRs in the system. Enter the command in EXEC mode to roll back the committed software set for the SDR to which you are currently logged in. You can also roll back the committed software for a specific SDR in administration EXEC mode by using the **sdr sdr-name** keyword and argument. s

Additional References

The following sections provide references related to software package management on Cisco IOS XR software.

Related Documents

| Related Topic | Document Title |
|-------------------------------|---|
| Cisco IOS XR install commands | <i>Software Package Management Commands on the Cisco IOS XR Software module of System Management Command Reference for isco CRS Routers</i> |

| Related Topic | Document Title |
|--|--|
| Cisco IOS XR getting started material | <i>Cisco IOS XR Getting Started Guide for the Cisco CRS Router</i> |
| Cisco IOS XR master command index | <i>Cisco IOS XR Commands Master List for the Cisco CRS Router</i> |
| Information about user groups and task IDs | <i>Configuring AAA Services on the Cisco IOS XR Software module of System Security Configuration Guide for Cisco CRS Routers</i> |
| ROM Monitor | <i>ROM Monitor Configuration Guide for Cisco CRS Routers</i> |

Standards

| Standards | Title |
|---|-------|
| No new or modified standards are supported by this feature, and support for existing standards has not been modified by this feature. | — |

MIBs

| MIBs | MIBs Link |
|------|--|
| — | To locate and download MIBs using Cisco IOS XR software, use the Cisco MIB Locator found at the following URL and choose a platform under the Cisco Access Products menu: http://cisco.com/public/sw-center/netmgmt/ctmk/mibs.shtml |

RFCs

| RFCs | Title |
|---|-------|
| No new or modified RFCs are supported by this feature, and support for existing RFCs has not been modified by this feature. | — |

Technical Assistance

| Description | Link |
|---|---|
| The Cisco Technical Support website contains thousands of pages of searchable technical content, including links to products, technologies, solutions, technical tips, and tools. Registered Cisco.com users can log in from this page to access even more content. | http://www.cisco.com/cisco/web/support/index.html |

