



IPsec and ISAKMP

- [About Tunneling, IPsec, and ISAKMP, on page 1](#)
- [Licensing for IPsec VPNs, on page 6](#)
- [Guidelines for IPsec VPNs, on page 7](#)
- [Configure ISAKMP, on page 7](#)
- [Configure IPsec, on page 18](#)
- [Managing IPsec VPNs, on page 38](#)

About Tunneling, IPsec, and ISAKMP

This topic describes the Internet Protocol Security (IPsec) and the Internet Security Association and Key Management Protocol (ISAKMP) standards used to build Virtual Private Networks (VPNs).

Tunneling makes it possible to use a public TCP/IP network, such as the Internet, to create secure connections between remote users and a private corporate network. Each secure connection is called a tunnel.

The ASA uses the ISAKMP and IPsec tunneling standards to build and manage tunnels. ISAKMP and IPsec accomplish the following:

- Negotiate tunnel parameters
- Establish tunnels
- Authenticate users and data
- Manage security keys
- Encrypt and decrypt data
- Manage data transfer across the tunnel
- Manage data transfer inbound and outbound as a tunnel endpoint or router

The ASA functions as a bidirectional tunnel endpoint. It can receive plain packets from the private network, encapsulate them, create a tunnel, and send them to the other end of the tunnel where they are unencapsulated and sent to their final destination. It can also receive encapsulated packets from the public network, unencapsulate them, and send them to their final destination on the private network.

IPsec Overview

The ASA uses IPsec for LAN-to-LAN VPN connections and provides the option of using IPsec for client-to-LAN VPN connections. In IPsec terminology, a *peer* is a remote-access client or another secure gateway. For both connection types, the ASA supports only Cisco peers. Because we adhere to VPN industry standards, ASAs can work with other vendors' peers; however, we do not support them.

During tunnel establishment, the two peers negotiate security associations (SAs) that govern authentication, encryption, encapsulation, and key management. These negotiations involve two phases: first, to establish the tunnel (the IKE SA) and second, to govern traffic within the tunnel (the IPsec SA).

A LAN-to-LAN VPN connects networks in different geographic locations. In IPsec LAN-to-LAN connections, the ASA can function as initiator or responder. In IPsec client-to-LAN connections, the ASA functions only as responder. Initiators propose SAs; responders accept, reject, or make counter-proposals—all in accordance with configured SA parameters. To establish a connection, both entities must agree on the SAs.

Understanding IPsec Tunnels

IPsec tunnels are sets of SAs that the ASA establishes between peers. The SAs specify the protocols and algorithms to apply to sensitive data and also specify the keying material that the peers use. IPsec SAs control the actual transmission of user traffic. SAs are unidirectional, but are generally established in pairs (inbound and outbound).

The peers negotiate the settings to use for each SA. Each SA consists of the following:

- IKEv1 transform sets or IKEv2 proposals
- Crypto maps
- ACLs
- Tunnel groups
- Prefragmentation policies

ISAKMP and IKE Overview

ISAKMP is the negotiation protocol that lets two hosts agree on how to build an IPsec security association (SA). It provides a common framework for agreeing on the format of SA attributes. This security association includes negotiating with the peer about the SA and modifying or deleting the SA. ISAKMP separates negotiation into two phases: Phase 1 and Phase 2. Phase 1 creates the first tunnel, which protects later ISAKMP negotiation messages. Phase 2 creates the tunnel that protects data.

IKE uses ISAKMP to set up the SA for IPsec to use. IKE creates the cryptographic keys used to authenticate peers.

The ASA supports IKEv1 for connections from the legacy Cisco VPN client, and IKEv2 for the AnyConnect VPN client.

To set the terms of the ISAKMP negotiations, you create an IKE policy, which includes the following:

- The authentication type required of the IKEv1 peer, either RSA signature using certificates or preshared key (PSK).
- An encryption method to protect the data and ensure privacy.

- A Hashed Message Authentication Codes (HMAC) method to ensure the identity of the sender, and to ensure that the message has not been modified in transit.
- A Diffie-Hellman group to determine the strength of the encryption-key-determination algorithm. The ASA uses this algorithm to derive the encryption and hash keys.
- For IKEv2, a separate pseudo-random function (PRF) used as the algorithm to derive keying material and hashing operations required for the IKEv2 tunnel encryption and so on.
- A limit to the time the ASA uses an encryption key before replacing it.

With IKEv1 policies, you set one value for each parameter. For IKEv2, you can configure multiple encryption and authentication types, and multiple integrity algorithms for a single policy. The ASA orders the settings from the most secure to the least secure and negotiates with the peer using that order. This ordering allows you to potentially send a single proposal to convey all the allowed transforms instead of sending each allowed combination as with IKEv1.

The ASA does not support IKEv2 multiple security associations (SAs). The ASA currently accepts inbound IPsec traffic only on the first SA that is found. If IPsec traffic is received on any other SA, it is dropped with reason `vpn-overlap-conflict`. Multiple IPsec SAs can come about from duplicate tunnels between two peers, or from asymmetric tunneling.

Understanding IKEv1 Transform Sets and IKEv2 Proposals

An IKEv1 transform set or an IKEv2 proposal is a combination of security protocols and algorithms that define how the ASA protects data. During IPsec SA negotiations, the peers must identify a transform set or proposal that is the same at both peers. The ASA then applies the matching transform set or proposal to create an SA that protects data flows in the ACL for that crypto map.

With IKEv1 transform sets, you set one value for each parameter. For IKEv2 proposals, you can configure multiple encryption and authentication types and multiple integrity algorithms for a single proposal. The ASA orders the settings from the most secure to the least secure and negotiates with the peer using that order. This allows you to potentially send a single proposal to convey all the allowed combinations instead of the need to send each allowed combination individually as with IKEv1.

The ASA tears down the tunnel if you change the definition of the transform set or proposal used to create its SA. See the [Clear Security Associations, on page 39](#) for further information.



Note If you clear or delete the only element in a transform set or proposal, the ASA automatically removes the crypto map references to it.

About IKEv2 Multi-Peer Crypto Map

Beginning with the 9.14(1) release, ASA IKEv2 supports multi-peer crypto map—when a peer in a tunnel goes down, IKEv2 attempts to establish the tunnel with the next peer in the list. You can configure crypto map with a maximum of 10 peer addresses. This multiple peer support on IKEv2 is useful, especially, when you are migrating from IKEv1 with multi-peer crypto maps.

IKEv2 supports only bi-directional crypto maps. Hence, the multiple peers are also configured on bi-directional crypto maps, and the same is used to accept the request from peers initiating the tunnel.

IKEv2 Initiator Behavior

IKEv2 initiates session with a peer, say Peer1. If Peer1 is unreachable for 5 SA_INIT retransmits, a final retransmit is sent. This activity takes about 2 minutes.

When Peer1 fails, the SA_INIT message is sent to Peer2. If Peer2 is also unreachable, session establishment is initiated with Peer3 after 2 minutes.

After all the peers are exhausted in the peer list of the crypto map, IKEv2 initiates the session again from Peer1 until a SA is established with any of the peers. The following figure depicts this behavior.

Figure 1: Initiator Process Flow

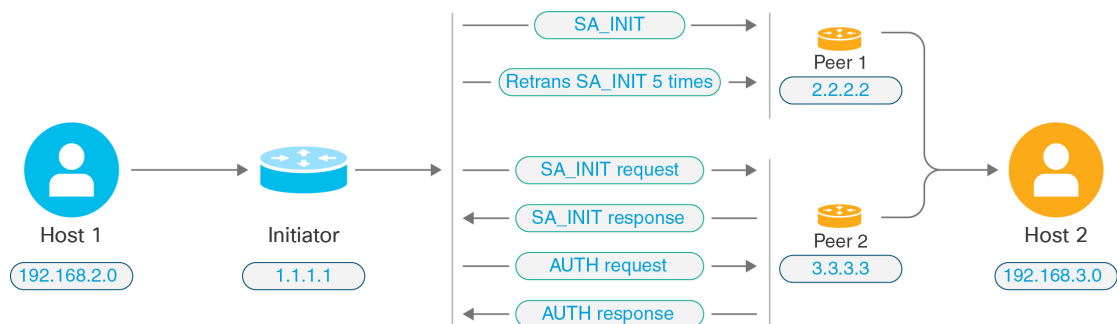

Note Continuous traffic is required to initiate IKE SA so that each failure attempt would move to the next peer and finally some reachable peer establishes the SA. In cases of disrupted traffic, a manual trigger is needed to initiate the IKE SA with the next peer.

IKEv2 Responder Behavior

If the responder device of IKE SA is configured with multiple peers in the crypto map, whenever an IKE SA is attempted, the address of the initiator IKE SA is validated with that of the current active peer in the crypto map.

For example, if the current active peer in the crypto map (being used as Responder) is the first peer, then the IKE SA is initiated from Peer1 IP address. Similarly, if the current active peer in the crypto map (being used as Responder) is the second peer, then IKE SA is initiated from Peer2 IP address.



Note Peer traversal is not supported on the Responder Side of a IKEv2 multi-peer topology.

Peer Index Reset Upon Crypto Map Changes

Any change to the crypto map resets the peer index to zero, and the tunnel initiation starts from first peer in the list. Following table provides multiple peer index transition under specific conditions:

Table 1: Multi-Peer Index Transition before SA

Conditions prior to SA	Peer Index Moved Yes/No/Reset
Peer not reachable	Yes
Phase 1 proposal mismatch	Yes
Phase 2 proposal mismatch	Yes
DPD ack not received	Yes
Traffic selectors mismatch during AUTH phase	Yes
Authentication failure	Yes
Rekey failure due to peer not reachable	Reset

Table 2: Multi-Peer Index Transition after SA

Conditions after SA	Peer Index Moved Yes/No/Reset
Rekey failure due to proposal mismatch	Reset
Traffic selectors mismatch during rekey	Reset
Crypto map modification	Reset
HA switchover	No
Clear crypto IKEv2 SA	Reset
Clear ipsec sa	Reset
IKEv2 SA timeout	Reset

Guidelines for IKEv2 Multi-Peer

IKEv1 and IKEv2 Protocols

If a crypto map is configured with both the IKE versions and multiple peers, SA attempt is made on each peer with both versions before moving to next peer.

For example, if a crypto map is configured with two peers, say P1 and P2, then the tunnel is initiated to P1 with IKEv2, P1 with IKEv1, P2 with IKEv2, and so on.

High Availability

A crypto map with multiple peers initiates tunnels to the Responder device that is in HA. It moves to the next Responder device when the first device isn't reachable.

An initiator device initiates tunnels to the Responder device. If the active device goes down, the standby device attempts to establish the tunnel from the Peer1 IP address, irrespective of the crypto map moving to the Peer2 IP address on the active device.

Centralized Cluster

A crypto map with multiple peers can initiate tunnels to the Responder device that is in a Centralized cluster deployment. If the first device is unreachable, it attempts to move to the next Responder device.

An initiator device initiates tunnels to the Responder device. Every node in the cluster moves to the next Peer2, if Peer1 isn't reachable.

Distributed Cluster

Distributed clustering isn't supported when an IKEv2 multi-peer crypto map is configured.

Multiple Context Modes

In multiple context modes, multi-peer behavior is specific to each context.

Debug Command

If the tunnel establishment fails, enable these commands to further analyse the issue.

- `debug crypto ikev2 platform 255`
- `debug crypto ikev2 protocol 255`
- `debug crypto ike-common 255`

The following example is that of a debug log that is specific to IKEv2 multi-peer, which displays the transition of peers.

```
Sep 13 10:08:58 [IKE COMMON DEBUG]Failed to initiate ikev2 SA with peer 192.168.2.2,
initiate to next peer 192.168.2.3 configured in the multiple peer list of the crypto map.
```

Licensing for IPsec VPNs



Note This feature is not available on No Payload Encryption models.

IPsec remote access VPN using IKEv2 requires an AnyConnect Plus or Apex license, available separately. IPsec remote access VPN using IKEv1 and IPsec site-to-site VPN using IKEv1 or IKEv2 uses the Other VPN license that comes with the Essentials license. See [Cisco ASA Series Feature Licenses](#) for maximum values per model.

Guidelines for IPsec VPNs

Context Mode Guidelines

Supported in single or multiple context mode. Anyconnect Apex license is required for remote-access VPN in multi-context mode. Although ASA does not specifically recognize an AnyConnect Apex license, it enforces licenses characteristics of an Apex license such as AnyConnect Premium licensed to the platform limit, Secure Client for mobile, Secure Client for Cisco VPN phone, and advanced endpoint assessment.

Firewall Mode Guidelines

Supported in routed firewall mode only. Does not support transparent firewall mode.

Failover Guidelines

IPsec VPN sessions are replicated in Active/Standby failover configurations only.

Additional Guidelines

When you configure IKE, the system automatically reserves the RADIUS UDP ports 1645 and 1646. This reservation is noted in syslog 713903, where the port numbers are shown as 27910 and 28166. This reservation ensures that the ports do not get used for PAT translations.

Configure ISAKMP

Configure IKEv1 and IKEv2 Policies

IKEv1 and IKEv2 each support a maximum of 20 IKE policies, each with a different set of values. Assign a unique priority to each policy that you create. The lower the priority number, the higher the priority.

When IKE negotiations begin, the peer that initiates the negotiation sends all of its policies to the remote peer, and the remote peer tries to find a match. The remote peer checks all of the peer's policies against each of its configured policies in priority order (highest priority first) until it discovers a match.

A match exists when both policies from the two peers contain the same encryption, hash, authentication, and Diffie-Hellman parameter values. For IKEv1, the remote peer policy must also specify a lifetime less than or equal to the lifetime in the policy the initiator sent. If the lifetimes are not identical, the ASA uses the shorter lifetime. For IKEv2 the lifetime is not negotiated but managed locally between each peer, making it possible to configure lifetime independently on each peer. If no acceptable match exists, IKE refuses negotiation and the SA is not established.

There is an implicit trade-off between security and performance when you choose a specific value for each parameter. The level of security the default values provide is adequate for the security requirements of most organizations. If you are interoperating with a peer that supports only one of the values for a parameter, your choice is limited to that value.

You must include the priority in each of the ISAKMP commands. The priority number uniquely identifies the policy and determines the priority of the policy in IKE negotiations.

Procedure

Step 1 To create an IKE policy, enter the **crypto ikev1 | ikev2 policy** command from global configuration mode in either single or multiple context mode. The prompt displays IKE policy configuration mode.

Example:

```
hostname(config)# crypto ikev1 policy 1
```

Note New ASA configurations do not have a default IKEv1 or IKEv2 policy.

Step 2 Specify the encryption algorithm. The default is AES-128.

encryption [aes | aes-192 | aes-256]

Example:

```
hostname(config-ikev1-policy)#  
encryption aes
```

Step 3 Specify the hash algorithm. The default is SHA-1.

hash[sha]

Example:

```
hostname(config-ikev1-policy)#  
hash sha
```

Step 4 Specify the authentication method. The default is preshared keys.

authentication[pre-shared]rsa-sig]

Example:

```
hostname(config-ikev1-policy)# authentication rsa-sig
```

Step 5 Specify the Diffie-Hellman group identifier. The default is Group 14.

group [14]

Example:

```
hostname(config-ikev1-policy)#  
group 14
```

Step 6 Specify the SA lifetime. The default is 86400 seconds (24 hours).

lifetime seconds

Example:

This examples sets a lifetime of 4 hours (14400 seconds):

```
hostname(config-ikev1-policy)# lifetime 14400
```

- Step 7** Specify additional settings using the IKEv1 and IKEv2 policy keywords and their values provided in [IKE Policy Keywords and Values, on page 9](#). If you do not specify a value for a given policy parameter, the default value applies.

IKE Policy Keywords and Values

	Keyword	Meaning	Description
authentication	rsa-sig	A digital certificate with keys generated by the RSA signatures algorithm	Specifies the authentication method the ASA uses to establish the identity of each IPsec peer.
	pre-share (default)	Preshared keys	Preshared keys do not scale well with a growing network but are easier to set up in a small network.
encryption	aes (default)	AES with a 128-bit key	Specifies the symmetric encryption algorithm that protects data transmitted between two IPsec peers. The default is 128 -bit key.
hash	sha (default)	SHA-1 (HMAC variant)	Specifies the hash algorithm used to ensure data integrity. It ensures that a packet comes from where it says it comes from and that it has not been modified in transit.
group			
	14 (default)	Group 14 (2048-bit)	Specifies the Diffie-Hellman group identifier, which the two IPsec peers use to derive a shared secret without transmitting it to each other. The lower the Diffie-Hellman group number, the less CPU time it requires to execute. The higher the Diffie-Hellman group number, the greater the security. The default group is DH Group 14
lifetime	integer value (86400 = default)	120 to 2147483647 seconds	Specifies the SA lifetime. The default is 86,400 seconds or 24 hours. As a general rule, a shorter lifetime provides more secure ISAKMP negotiations (up to a point). However, with shorter lifetimes, the ASA sets up future IPsec SAs more quickly.
	Keyword	Meaning	Description
integrity	sha (default)	SHA-1 (HMAC variant)	Specifies the hash algorithm used to ensure data integrity. It ensures that a packet comes from where it says it comes from and that it has not been modified in transit.
	sha256	SHA 2, 256-bit digest	Specifies the Secure Hash Algorithm SHA 2 with the 256-bit digest.
	sha384	SHA 2, 384-bit digest	Specifies the Secure Hash Algorithm SHA 2 with the 384-bit digest.

	Keyword	Meaning	Description
	sha512	SHA 2, 512-bit digest	Specifies the Secure Hash Algorithm SHA 2 with the 512-bit digest.
	null		When AES-GCM is specified as the encryption algorithm, an administrator can choose null as the IKEv2 integrity algorithm.
encryption	aes (default)	AES	Specifies the symmetric encryption algorithm that protects data transmitted between two IPsec peers. The default is 128-bit AES.
	aes aes-192 aes-256		The Advanced Encryption Standard supports key lengths of 128, 192, 256 bits.
	aes-gcm aes-gcm-192 aes-gcm-256 null	AES-GCM algorithm options to use for IKEv2 encryption	The Advanced Encryption Standard supports key lengths of 128, 192, 256 bits.
policy_index			Accesses the IKEv2 policy sub-mode.
prf	sha (default)	SHA-1 (HMAC variant)	Specifies the pseudo random function (PRF)—the algorithm used to generate keying material.
	sha256	SHA 2, 256-bit digest	Specifies the Secure Hash Algorithm SHA 2 with the 256-bit digest.
	sha384	SHA 2, 384-bit digest	Specifies the Secure Hash Algorithm SHA 2 with the 384-bit digest.
	sha512	SHA 2, 512-bit digest	Specifies the Secure Hash Algorithm SHA 2 with the 512-bit digest.
priority			Extends the policy mode to support the additional IPsec V3 features and makes the AES-GCM and ECDH settings part of the Suite B support.
group	14 19 20 21 24	Group 14 (2048-bit)	Specifies the Diffie-Hellman group identifier, which the two IPsec peers use to derive a shared secret without transmitting it to each other. The lower the Diffie-Hellman group number, the less CPU time it requires to execute. The higher the Diffie-Hellman group number, the greater the security. The default is (DH) Group 14
lifetime	integer value (86400 = default)	120 to 2147483647 seconds	Specifies the SA lifetime. The default is 86,400 seconds or 24 hours. As a general rule, a shorter lifetime provides more secure ISAKMP negotiations (up to a point). However, with shorter lifetimes, the ASA sets up future IPsec SAs more quickly.

Enable IKE on the Outside Interface

You must enable IKE on the interface that terminates the VPN tunnel. Typically this is the outside, or public interface. To enable IKEv1 or IKEv2, use the `crypto [ikev1 | ikev2] enable interface-name` command from global configuration mode in either single or multiple context mode.

For example:

```
hostname(config)# crypto ikev1 enable outside
```

Enable or Disable IKEv1 Aggressive Mode

Phase 1 IKEv1 negotiations can use either main mode or aggressive mode. Both provide the same services, but aggressive mode requires only two exchanges between the peers totaling three messages, rather than three exchanges totaling six messages. Aggressive mode is faster, but does not provide identity protection for the communicating parties. Therefore, the peers must exchange identification information before establishing a secure SA. Aggressive mode is enabled by default.



Note Disabling aggressive mode prevents Cisco VPN clients from using preshared key authentication to establish tunnels to the ASA. However, they may use certificate-based authentication (that is, ASA or RSA) to establish tunnels.

To enable aggressive mode for phase 1 IKEv1 negotiations, enter the following command in either single or multiple context mode:

```
hostname(config)# crypto map <map-name> seq-num set ikev1 phase1-mode aggressive <group-name>
```

To disable aggressive mode, enter the following command in either single or multiple context mode:

```
hostname(config)# crypto ikev1 am-disable
```

If you have disabled aggressive mode, and want to revert back to it, use the `no` form of the command. For example:

```
hostname(config)# no crypto ikev1 am-disable
```

Configure an ID Method for IKEv1 and IKEv2 ISAKMP Peers

During IKEv1 or IKEv2 ISAKMP Phase I negotiations, the peers must identify themselves to each other. You can choose the identification method from the following options.

Address	Uses the IP addresses of the hosts exchanging ISAKMP identity information.
Automatic (default)	Determines ISAKMP negotiation by connection type: <ul style="list-style-type: none"> • IP address for preshared key. • Cert Distinguished Name for certificate authentication.

Hostname	Uses the fully qualified domain name of the hosts exchanging ISAKMP identity information (default). This name comprises the hostname and the domain name.
Key ID <i>key_id_string</i>	Specifies the string used by the remote peer to look up the preshared key.

The ASA uses the Phase I ID to send to the peer. This is true for all VPN scenarios except LAN-to-LAN IKEv1 connections in main mode that authenticate with preshared keys.

To change the peer identification method, enter the following command in either single or multiple context mode:

```
crypto isakmp identity {address | hostname | key-id id-string | auto}
```

For example, the following command sets the peer identification method to hostname:

```
hostname(config)# crypto isakmp identity hostname
```

INVALID_SELECTORS Notification

If an IPsec system receives an inbound packet on an SA and the packet's header fields are not consistent with the selectors for the SA, it MUST discard the packet. The audit log entry for this event includes the current date/time, SPI, IPsec protocol(s), source and destination of the packet, any other vector values of the packet that are available, and the selector values from the relevant SA entry. The system generates and sends an IKE notification of INVALID_SELECTORS to the sender (IPsec peer), indicating that the received packet was discarded because of failure to pass selector checks.

The ASA already implements the logging of this event in CTM using the existing syslog shown below:

```
%ASA-4-751027: IKEv2 Received INVALID_SELECTORS Notification from peer: <peer IP>. Peer received a packet (SPI=<spi>) from <local_IP>. The decapsulated inner packet didn't match the negotiated policy in the SA. Packet destination <pkt_daddr>, port <pkt_dest_port>, source <pkt_saddr>, port <pkt_src_port>, protocol <pkt_prot>
```

An administrator can now enable or disable sending an IKEv2 notification to the peer when an inbound packet is received on an SA that does not match the traffic selectors for that SA. If enabled, the IKEv2 notification messages are rate limited to one notification message per SA every five seconds. The IKEv2 notification is sent in an IKEv2 informational exchange to the peer.

Configure IKEv2 Pre-shared Key in Hex

You can configure the IKEv2 pre-shared keys in Hex by adding the keyword *hex* to both the local and remote pre-shared key commands.

```
ikev2 local-authentication pre-shared-key [ 0 | 8 | hex ] <string>
ikev2 remote-authentication pre-shared-key [ 0 | 8 | hex ] <string>
```

Enable or Disable Sending of IKE Notification

An administrator can enable or disable sending an IKE notification to the peer when an inbound packet is received on an IKEv2 IPsec VPN connection that does not match the traffic selectors for that connection.

Sending this notification is disabled by default. Sending IKE INVALID_SELECTORS Notifications when Authorization of a username from ASDM certificate is enabled or disabled using the following CLI:

```
[no] crypto ikev2 notify invalid-selectors
```

When certificate authentication is performed, the CN from the certificate is the username, and authorization is performed against the LOCAL server. If “service-type” attribute is retrieved, it is processed as described earlier.

Configure IKEv2 Fragmentation Options

On the ASA, IKEv2 fragmentation can be enabled or disabled, the MTU (Maximum Transmission Unit) used when fragmenting IKEv2 packets can be specified, and a preferred fragmentation method can be configured by the administrator using the following command:

```
[no] crypto ikev2 fragmentation [mtu <mtu-size>] | [preferred-method [ietf | cisco]]
```

By default, all methods of IKEv2 fragmentation are enabled, the MTU is 576 for IPv4, or 1280 for IPv6, and the preferred method is the IETF standard RFC-7383.

Specify the [mtu <mtu-size>] with the following considerations:

- The MTU value used should include the IP(IPv4/IPv6) header + UDP header size.
- If not specified by the administrator the default MTU is 576 for IPv4, or 1280 for IPv6.
- Once specified, the same MTU will be used for both IPv4 and IPv6.
- Valid range is 68-1500.



Note You must consider the ESP overhead while configuring the MTU. The packet size increases after encryption due to the ESP overhead that is added to the MTU during the encryption. If you get the "packet too big" error, ensure that you check the MTU size and configure a lower MTU.

One of the following supported fragmentation methods can be configured as the preferred fragmentation method for IKEv2 [preferred-method [ietf | cisco]]:

- IETF RFC-7383 standard based IKEv2 fragmentation.
 - This method will be used when both peers specify support and preference during negotiation.
 - Using this method, encryption is done after fragmentation providing individual protection for each IKEv2 Fragment message.
- Cisco proprietary fragmentation.
 - This method will be used if it is the only method provided by a peer, such as the Secure Client, or if both peers specify support and preference during negotiation.
 - Using this method fragmentation is done after encryption. The receiving peer cannot decrypt or authenticate the message until all fragments are received.
 - This method does not interoperate with non-Cisco peers.

The command **show running-config crypto ikev2** will display the current configuration, and **show crypto ikev2 sa detail** displays the MTU enforced if fragmentation was used for the SA.

Before you begin

- Path MTU Discovery is not supported, the MTU needs to be manually configured to match the needs of the network.
- This configuration is global and will affect future SAs established after the configuration has been applied. Older SAs will not be affected. Same behavior holds true when fragmentation is disabled.
- A maximum of a 100 fragments can be received.

Examples

- To disable IKEv2 fragmentation:

```
no crypto ikev2 fragmentation
```

- To reinstate the default operation:

```
crypto ikev2 fragmentation
```

or

```
crypto ikev2 fragmentation mtu 576  
preferred-method ietf
```

- To change the MTU value to 600:

```
crypto ikev2 fragmentation mtu 600
```

- To restore the default MTU value:

```
no crypto ikev2 fragmentation mtu 576
```

- To change the preferred method of fragmentation to Cisco:

```
crypto ikev2 fragmentation preferred-method cisco
```

- To restore the preferred fragmentation method to IETF:

```
no crypto ikev2 fragmentation preferred-method cisco
```

or

```
crypto ikev2 fragmentation preferred-method ietf
```

AAA Authentication With Authorization

```
aaa authentication http console LOCAL  
aaa authorization http console radius
```

AAA authentication is performed against the LOCAL server using the username/password typed in by the user. Additional authorization is performed against the *radius* server using the same username. *service-type* attribute, if retrieved, is processed as described earlier.

Enable IPsec over NAT-T

NAT-T lets IPsec peers establish a connection through a NAT device. It does this by encapsulating IPsec traffic in UDP datagrams, using port 4500, which provides NAT devices with port information. NAT-T auto-detects any NAT devices and only encapsulates IPsec traffic when necessary.



Note Due to a limitation of the Secure Client, you must enable NAT-T for the Secure Client to successfully connect using IKEv2. This requirement applies even if the client is not behind a NAT-T device.

The ASA can simultaneously support standard IPsec, IPsec over TCP, NAT-T, and IPsec over UDP, depending on the client with which it is exchanging data.

The following breakdown shows the connections with each option enabled.

Options	Enabled Feature	Client Position	Feature Used
Option 1	If NAT-T is enabled	and client is behind NAT, then	NAT-T is used
		and no NAT exists, then	Native IPsec (ESP) is used
Option 2	If IPsec over UDP is enabled	and client is behind NAT, then	IPsec over UDP is used
		and no NAT exists, then	IPsec over UDP is used
Option 3	If both NAT-T and IPsec over UDP are enabled	and client is behind NAT, then	NAT-T is used
		and no NAT exists, then	IPsec over UDP is used



Note When IPsec over TCP is enabled, it takes precedence over all other connection methods.

When you enable NAT-T, the ASA automatically opens port 4500 on all IPsec-enabled interfaces.

The ASA supports multiple IPsec peers behind a single NAT/PAT device operating in LAN-to-LAN or remote access networks, but not both. In a mixed environment, the remote access tunnels fail the negotiation because all peers appear to be coming from the same public IP address, address of the NAT device. Also, remote access tunnels fail in a mixed environment because they often use the same name as the LAN-to-LAN tunnel group (that is, the IP address of the NAT device). This match can cause negotiation failures among multiple peers in a mixed LAN-to-LAN and remote access network of peers behind the NAT device.

To use NAT-T, perform the following site-to-site steps in either single or multiple context mode:

Procedure

Step 1 Enter the following command to enable IPsec over NAT-T globally on the ASA:

```
crypto isakmp nat-traversal natkeepalive
```

The range for the `natkeepalive` argument is 10 to 3600 seconds. The default is 20 seconds.

Example:

Enter the following command to enable NAT-T and set the keepalive value to one hour:

```
hostname(config)# crypto isakmp nat-traversal 3600
```

Step 2 Select the before-encryption option for the IPsec fragmentation policy by entering this command:

```
hostname(config)# crypto ipsec fragmentation before-encryption
```

This option lets traffic travel across NAT devices that do not support IP fragmentation. It does not impede the operation of NAT devices that do support IP fragmentation.

Enable IPsec with IKEv1 over TCP

IPsec over TCP encapsulates both the IKEv1 and IPsec protocols within a TCP-like packet and enables secure tunneling through both NAT and PAT devices and firewalls. This feature is disabled by default. IPsec/IKEv1 over TCP enables a Cisco VPN client to operate in an environment in which standard ESP or IKEv1 cannot function or can function only with modification to existing firewall rules.



Note This feature does not work with proxy-based firewalls.

IPsec over TCP works with remote access clients. You enable IPsec over TCP on both the ASA and the client to which it connects. On the ASA, it is enabled globally, working on all IKEv1-enabled interfaces. It does not work for LAN-to-LAN connections.

The ASA can simultaneously support standard IPsec, IPsec over TCP, NAT-Traversal, and IPsec over UDP, depending on the client with which it is exchanging data. IPsec over TCP, if enabled, takes precedence over all other connection methods.

You can enable IPsec over TCP for up to 10 ports that you specify. If you enter a well-known port, for example port 80 (HTTP) or port 443 (HTTPS), the system displays a warning that the protocol associated with that port no longer works on the public interface. The consequence is that you can no longer use a browser to manage the ASA through the public interface. To solve this problem, reconfigure the HTTP/HTTPS management to different ports.

The default port is 10000.

You must configure TCP port(s) on the client as well as on the ASA. The client configuration must include at least one of the ports you set for the ASA.

To enable IPsec over TCP for IKEv1 globally on the ASA, perform the following command in either single or multiple context mode:

```
crypto ikev1 ipsec-over-tcp [port port 1...port0]
```

This example enables IPsec over TCP on port 45:

```
hostname(config)# crypto ikev1 ipsec-over-tcp port 45
```

Configure Certificate Group Matching for IKEv1

Tunnel groups define user connection terms and permissions. Certificate group matching lets you match a user to a tunnel group using either the Subject DN or Issuer DN of the user certificate.



Note Certificate group matching applies to IKEv1 and IKEv2 LAN-to-LAN connections only. IKEv2 remote access connections support the pull-down group selection configured in the `webvpn-attributes` of the `tunnel-group` and `webvpn` configuration mode for `certificate-group-map`, and so on.

To match users to tunnel groups based on these fields of the certificate, you must first create rules that define a matching criteria, and then associate each rule with the desired tunnel group.

To create a certificate map, **use the `crypto ca certificate map` command**. To define a tunnel group, use the `tunnel-group` command.

You must also configure a certificate group matching policy, specifying to match the group from the rules, or from the organizational unit (OU) field, or to use a default group for all certificate users. You can use any or all of these methods.

Procedure

Step 1 To configure the policy and rules by which certificate-based ISAKMP sessions map to tunnel groups, and to associate the certificate map entries with tunnel groups, enter the `tunnel-group-map` command in either single or multiple context mode.

```
tunnel-group-map enable {rules | ou | ike-id | peer ip}
```

```
tunnel-group-map [rule-index] enable policy
```

<i>policy</i>	Specifies the policy for deriving the tunnel group name from the certificate. Policy can be one of the following: <i>ike-id</i> —Indicates that if a tunnel group is not determined based on a rule lookup or taken from the OU, then the certificate-based ISAKMP sessions are mapped to a tunnel group based on the content of the phase1 ISAKMP ID. <i>ou</i> —Indicates that if a tunnel-group is not determined based on a rule lookup, then use the value of the OU in the subject distinguished name (DN). <i>peer-ip</i> —Indicates that if a tunnel group is not determined based on a rule lookup or taken from the OU or ike-id methods, then use the peer IP address. <i>rules</i> —Indicates that the certificate-based ISAKMP sessions are mapped to a tunnel group based on the certificate map associations configured by this command.
<i>rule index</i>	(Optional) Refers to parameters specified by the crypto ca certificate map command. The values are 1 to 65535.

Be aware of the following:

- You can invoke this command multiple times as long as each invocation is unique and you do not reference a map index more than once.

- Rules cannot be longer than 255 characters.
- You can assign multiple rules to the same group. To do that, you add the rule priority and group first. Then you define as many criteria statements as you need for each group. When multiple rules are assigned to the same group, a match results for the first rule that tests true.
- By creating a single rule, you can require all criteria to match before assigning a user to a specific tunnel group. Requiring all criteria to match is equivalent to a logical AND operation. Alternatively, create one rule for each criterion if you want to require that only one match before assigning a user to a specific tunnel group. Requiring only one criterion to match is equivalent to a logical OR operation.

Step 2 Specify a default tunnel group to use when the configuration does not specify a tunnel group.

The syntax is **tunnel-group-map** [*rule-index*] **default-group** *tunnel-group-name* where *rule-index* is the priority for the rule, and tunnel-group name must be for a tunnel group that already exists.

Examples

The following example enables mapping of certificate-based ISAKMP sessions to a tunnel group based on the content of the phase1 ISAKMP ID:

```
hostname(config)# tunnel-group-map enable ike-id
```

The following example enables mapping of certificate-based ISAKMP sessions to a tunnel group based on the IP address of the peer:

```
hostname(config)# tunnel-group-map enable peer-ip
```

The following example enables mapping of certificate-based ISAKMP sessions based on the organizational unit (OU) in the subject distinguished name (DN):

```
hostname(config)# tunnel-group-map enable ou
```

The following example enables mapping of certificate-based ISAKMP sessions based on established rules:

```
hostname(config)# tunnel-group-map enable rules
```

Configure IPsec

This section describes the procedures required to configure the ASA when using IPsec to implement a VPN.

Define Crypto Maps

Crypto maps define the IPsec policy to be negotiated in the IPsec SA. They include the following:

- ACL to identify the packets that the IPsec connection permits and protects.
- Peer identification.
- Local address for the IPsec traffic. (See [Apply Crypto Maps to Interfaces](#), on page 27 for more details.)
- Up to 11 IKEv1 transform sets or IKEv2 proposals, with which to attempt to match the peer security settings.

A *crypto map set* consists of one or more crypto maps that have the same map name. You create a crypto map set when you create its first crypto map. The following site-to-site task creates or adds to a crypto map in either single or multiple context mode:

crypto map *map-name seq-num match address access-list-name*

Use the *access-list-name* to specify the ACL ID, as a string or integer up to 241 characters in length.



Tip Use all capital letters to more easily identify the ACL ID in your configuration.

You can continue to enter this command to add crypto maps to the crypto map set. In the following example, *mymap* is the name of the crypto map set to which you might want to add crypto maps:

crypto map mymap 10 match address 101

The *sequence number (seq-num)* shown in the syntax above distinguishes one crypto map from another one with the same name. The sequence number assigned to a crypto map also determines its priority among the other crypto maps within a crypto map set. The lower the sequence number, the higher the priority. After you assign a crypto map set to an interface, the ASA evaluates all IP traffic passing through the interface against the crypto maps in the set, beginning with the crypto map with the lowest sequence number.

[no] crypto map map_name map_index set pfs [group14 | group15 | group16 | group19 | group20 | group21]

Specifies the ECDH group used for Perfect Forward Secrecy (PFS) for the cryptography map. Prevents you from configuring group14 and group24 options for a cryptography map (when using an IKEv1 policy).

[no] crypto map map_name seq-num set reverse-route [dynamic]

Enables Reverse Route Injection (RRI) for any connection based on this crypto map entry. If *dynamic* is not specified, RRI is done upon configuration and is considered static, remaining in place until the configuration changes or is removed. Furthermore, whenever an RRI route is configured with same destination for which a static route already exist, the existing static route is discarded and the RRI route is installed. The ASA automatically adds static routes to the routing table and announces these routes to its private network or border routers using OSPF. Do not enable RRI if you specify any source/destination (0.0.0.0/0.0.0.0) as the protected network, because this will impact traffic that uses your default route.

If *dynamic* is specified, routes are created upon the successful establishment of IPsec security associations (SA's) and deleted after the IPsec SA's are deleted.

You cannot configure a dynamic crypto map with the same name as a static crypto map and vice versa, even if one of the crypto maps is not actually in use.



Note Dynamic RRI applies to IKEv2 based static crypto maps only.

[no] crypto map *name priority set validate-icmp-errors*

OR

[no] crypto dynamic-map *name priority set validate-icmp-errors*

Specifies whether incoming ICMP error messages are validated for the cryptography or dynamic cryptography map.

[no] crypto map *<name> <priority> set df-bit [clear-df | copy-df | set-df]*

OR

[no] crypto map dynamic-map *<name> <priority> set df-bit [clear-df | copy-df | set-df]*

Configures the existing do not fragment (DF) policy (at a security association level) for the cryptography or dynamic cryptography map.

- *clear-df*—Ignores the DF bit.
- *copy-df*—Maintains the DF bit.
- *set-df*—Sets and uses the DF bit.

[no] crypto map *<name> <priority> set tfc-packets [burst <length | auto> [payload-size <bytes | auto> [timeout <seconds | auto>]*

OR

[no] crypto dynamic-map *<name> <priority> set tfc-packets [burst <length | auto> [payload-size <bytes | auto> [timeout <seconds | auto>]*

An administrator can enable dummy Traffic Flow Confidentiality (TFC) packets at random lengths and intervals on an IPsec security association. You must have an IKEv2 IPsec proposal set before enabling TFC.



Note Enabling Traffic Flow Confidentiality packets prevents VPN idle timeout.

The ACL assigned to a crypto map consists of all of the ACEs that have the same ACL name, as shown in the following command syntax:

access-list *access-list-name {deny | permit} ip source source-netmask destination destination-netmask*

You create an ACL when you create its first ACE. The following command syntax creates or adds to an ACL:

access-list *access-list-name {deny | permit} ip source source-netmask destination destination-netmask*

In the following example, the ASA applies the IPsec protections assigned to the crypto map to all traffic flowing from the 10.0.0.0 subnet to the 10.1.1.0 subnet:

access-list 101 permit ip 10.0.0.0 255.255.255.0 10.1.1.0 255.255.255.0

The crypto map that matches the packet determines the security settings used in the SA negotiations. If the local ASA initiates the negotiation, it uses the policy specified in the static crypto map to create the offer to send to the specified peer. If the peer initiates the negotiation, the ASA attempts to match the policy to a static crypto map, and if that fails, then it attempts to match any dynamic crypto maps in the crypto map set, to decide whether to accept or reject the peer offer.

For two peers to succeed in establishing an SA, they must have at least one compatible crypto map. To be compatible, a crypto map must meet the following criteria:

- The crypto map must contain compatible crypto ACLs (for example, mirror image ACLs). If the responding peer uses dynamic crypto maps, so the ASA also must contain compatible crypto ACLs as a requirement to apply IPsec.
- Each crypto map identifies the other peer (unless the responding peer uses dynamic crypto maps).
- The crypto maps have at least one transform set or proposal in common.

You can apply only one crypto map set to a single interface. Create more than one crypto map for a particular interface on the ASA if any of the following conditions exist:

- You want specific peers to handle different data flows.
- You want different IPsec security to apply to different types of traffic.

For example, create a crypto map and assign an ACL to identify traffic between two subnets and assign one IKEv1 transform set or IKEv2 proposal. Create another crypto map with a different ACL to identify traffic between another two subnets and apply a transform set or proposal with different VPN parameters.

If you create more than one crypto map for an interface, specify a sequence number (seq-num) for each map entry to determine its priority within the crypto map set.

Each ACE contains a permit or deny statement. The following table explains the special meanings of permit and deny ACEs in ACLs applied to crypto maps.

Result of Crypto Map Evaluation	Response
Match criterion in an ACE containing a permit statement	Halt further evaluation of the packet against the remaining ACEs in the crypto map set, and evaluate the packet security settings against those in the IKEv1 transform sets or IKEv2 proposals assigned to the crypto map. After matching the security settings to those in a transform set or proposal, the ASA applies the associated IPsec settings. Typically for outbound traffic, this means that it decrypts, authenticates, and routes the packet.
Match criterion in an ACE containing a deny statement	Interrupt further evaluation of the packet against the remaining ACEs in the crypto map under evaluation, and resume evaluation against the ACEs in the next crypto map, as determined by the next seq-num assigned to it.
Fail to match all tested permit ACEs in the crypto map set	Route the packet without encrypting it.

ACEs containing deny statements filter out outbound traffic that does not require IPsec protection (for example, routing protocol traffic). Therefore, insert initial deny statements to filter outbound traffic that should not be evaluated against permit statements in a crypto ACL.

For an inbound, encrypted packet, the security appliance uses the source address and ESP SPI to determine the decryption parameters. After the security appliance decrypts the packet, it compares the inner header of the decrypted packet to the permit ACEs in the ACL associated with the packet SA. If the inner header fails to match the proxy, the security appliance drops the packet. If the inner header matches the proxy, the security appliance routes the packet.

When comparing the inner header of an inbound packet that was not encrypted, the security appliance ignores all deny rules because they would prevent the establishment of a Phase 2 SA.



Note To route inbound, unencrypted traffic as clear text, insert deny ACEs before permit ACEs. ASA cannot push more than 28 ACE in split-tunnel access-list.

Example of LAN-to-LAN Crypto Maps

The objective in configuring Security Appliances A, B, and C in this example LAN-to-LAN network is to permit tunneling of all traffic originating from one of the hosts and destined for one of the other hosts. However, because traffic from Host A.3 contains sensitive data from the Human Resources department, it requires strong encryption and more frequent rekeying than the other traffic. So you will want to assign a special transform set for traffic from Host A.3.

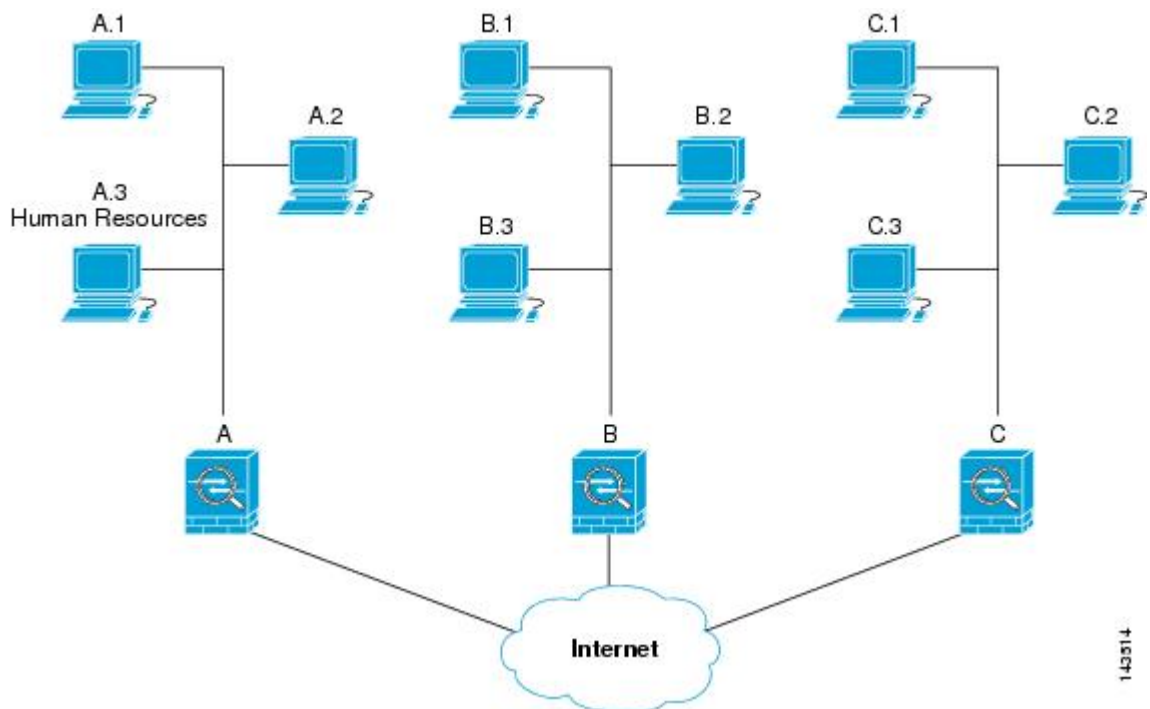

The simple address notation shown in this figure and used in the following explanation is an abstraction. An example with real IP addresses follows the explanation.

To configure Security Appliance A for outbound traffic, you create two crypto maps, one for traffic from Host A.3 and the other for traffic from the other hosts in Network A, as shown in the following example:

```
Crypto Map Seq_No_1
  deny packets from A.3 to B
  deny packets from A.3 to C
  permit packets from A to B
  permit packets from A to C
Crypto Map Seq_No_2
  permit packets from A.3 to B
  permit packets from A.3 to C
```

After creating the ACLs, you assign a transform set to each crypto map to apply the required IPsec to each matching packet.

Cascading ACLs involves the insertion of deny ACEs to bypass evaluation against an ACL and resume evaluation against a subsequent ACL in the crypto map set. Because you can associate each crypto map with different IPsec settings, you can use deny ACEs to exclude special traffic from further evaluation in the corresponding crypto map, and match the special traffic to permit statements in another crypto map to provide or require different security. The sequence number assigned to the crypto ACL determines its position in the evaluation sequence within the crypto map set.

The following illustration shows the cascading ACLs created from the conceptual ACEs in this example. The meaning of each symbol is defined as follows: .





	Crypto map within a crypto map set.
	(Gap in a straight line) Exit from a crypto map when a packet matches an ACE.
	Packet that fits the description of one ACE. Each size ball represents a different packet matching the respective ACE in the figure. The differences in size merely represent differences in the source and destination of each packet.
	Redirection to the next crypto map in the crypto map set.
	Response when a packet either matches an ACE or fails to match all of the permit ACEs in a crypto map set.

Figure 2: Cascading ACLs in a Crypto Map Set



Security Appliance A evaluates a packet originating from Host A.3 until it matches a permit ACE and attempts to assign the IPsec security associated with the crypto map. Whenever the packet matches a deny ACE, the ASA ignores the remaining ACEs in the crypto map and resumes evaluation against the next crypto map, as determined by the sequence number assigned to it. So in the example, if Security Appliance A receives a packet from Host A.3, it matches the packet to a deny ACE in the first crypto map and resumes evaluation of the packet against the next crypto map. When it matches the packet to the permit ACE in that crypto map, it applies the associated IPsec security (strong encryption and frequent rekeying).

To complete the ASA configuration in the example network, we assign mirror crypto maps to ASAs B and C. However, because ASAs ignore deny ACEs when evaluating inbound, encrypted traffic, we can omit the mirror equivalents of the deny A.3 B and deny A.3 C ACEs, and therefore omit the mirror equivalents of Crypto Map 2. So the configuration of cascading ACLs in ASAs B and C is unnecessary.

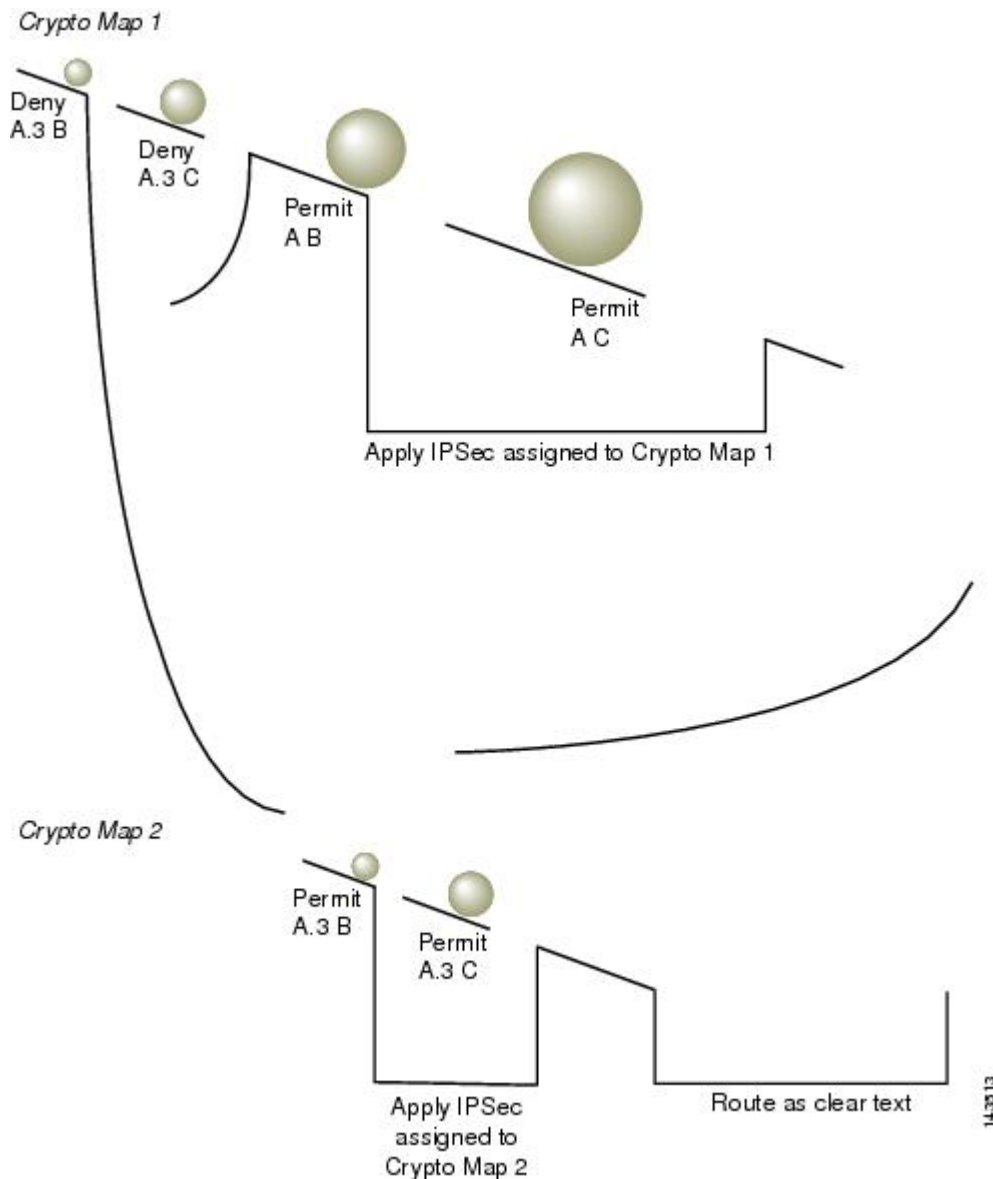
The following table shows the ACLs assigned to the crypto maps configured for all three ASAs, A, B and C:

Security Appliance A		Security Appliance B		Security Appliance C	
Crypto Map Sequence No.	ACE Pattern	Crypto Map Sequence No.	ACE Pattern	Crypto Map Sequence No.	ACE Pattern
1	deny A.3 B	1	permit B A	1	permit C A
	deny A.3 C				
	permit A B		permit B C		permit C B
	permit A C				
2	permit A.3 B	2	2	2	2
	permit A.3 C				

The following illustration maps the conceptual addresses shown previously to real IP addresses.

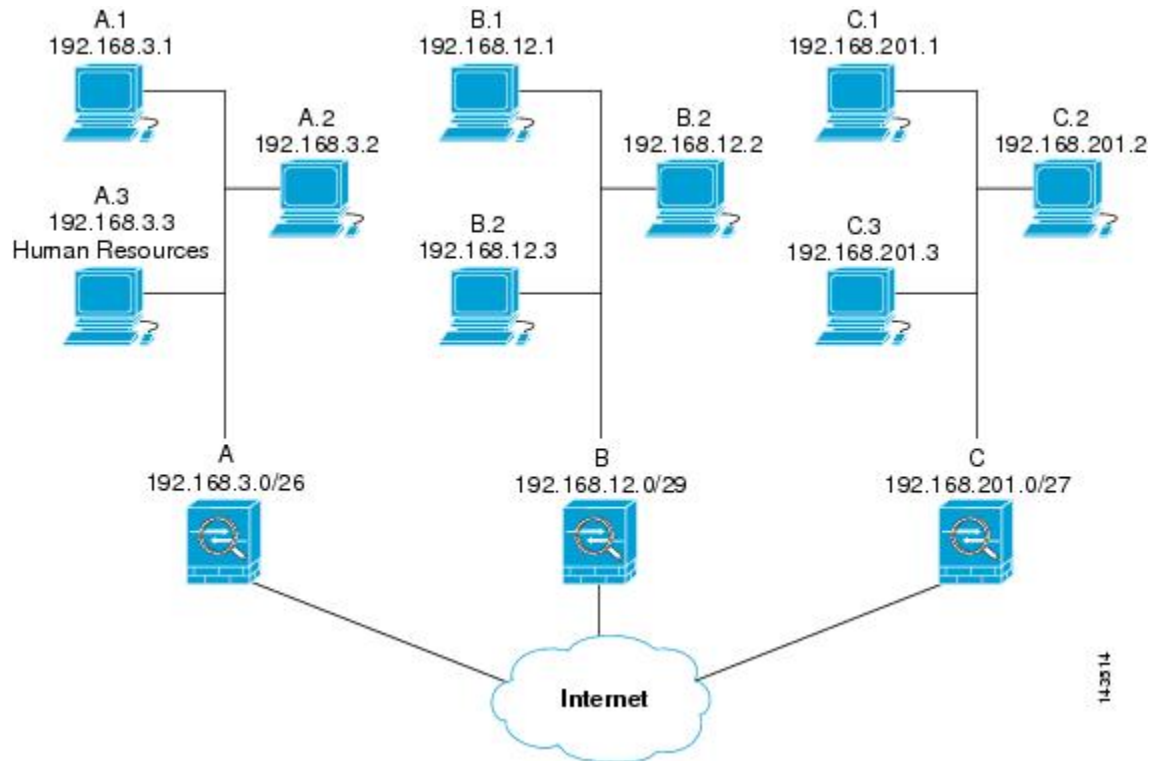

The real ACEs shown in the following table ensure that all IPsec packets under evaluation within this network receive the proper IPsec settings.

Security Appliance	Crypto Map Sequence No.	ACE Pattern	Real ACEs
A	1	deny A.3 B	deny 192.168.3.3 255.255.255.192 192.168.12.0 255.255.255.248
		deny A.3 C	deny 192.168.3.3 255.255.255.192 192.168.201.0 255.255.255.224
		permit A B	permit 192.168.3.0 255.255.255.192 192.168.12.0 255.255.255.248
		permit A C	permit 192.168.3.0 255.255.255.192 192.168.201.0 255.255.255.224
	2	permit A.3 B	permit 192.168.3.3 255.255.255.192 192.168.12.0 255.255.255.248
		permit A.3 C	permit 192.168.3.3 255.255.255.192 192.168.201.0 255.255.255.224
B	None needed	permit B A	permit 192.168.12.0 255.255.255.248 192.168.3.0 255.255.255.192
		permit B C	permit 192.168.12.0 255.255.255.248 192.168.201.0 255.255.255.224
C	None needed	permit C A	permit 192.168.201.0 255.255.255.224 192.168.3.0 255.255.255.192
		permit C B	permit 192.168.201.0 255.255.255.224 192.168.12.0 255.255.255.248

You can apply the same reasoning shown in the example network to use cascading ACLs to assign different security settings to different hosts or subnets protected by a ASA.



Note By default, the ASA does not support IPsec traffic destined for the same interface from which it enters. Names for this type of traffic include U-turn, hub-and-spoke, and hairpinning. However, you can configure IPsec to support U-turn traffic by inserting an ACE to permit traffic to and from the network. For example, to support U-turn traffic on Security Appliance B, add a conceptual “permit B B” ACE to ACL1. The actual ACE would be as follows: **permit 192.168.12.0 255.255.255.248 192.168.12.0 255.255.255.248**

Set Public Key Infrastructure (PKI) Keys

You must set public key infrastructure (PKI) in order for an administrator to choose the Suite B ECDSA algorithms when generating or zeroing a keypair:

Before you begin

If you are configuring a cryptography map to use an RSA or ECDSA trustpoint for authentication, you must first generate the key set. You can then create the trustpoint and reference it in the tunnel group configuration.

Procedure

Step 1 Choose the Suite B ECDSA algorithm when generating a keypair:

```
crypto key generate [rsa [general-keys | label <name> | modules [512 | 768 | 1024 | 2048 | 4096] | noconfirm | usage-keys] | ecdsa [label <name> | elliptic-curve [256 | 384 | 521] | noconfirm]]
```

- Step 2** Choose the Suite B ECDSA algorithm when zeroizing a keypair:
- ```
crypto key zeroize [rsa | ecdsa] [default | label <name> | noconfirm]
```
- 

## Apply Crypto Maps to Interfaces

You must assign a crypto map set to each interface through which IPsec traffic flows. The ASA supports IPsec on all interfaces. Assigning the crypto map set to an interface instructs the ASA to evaluate all the traffic against the crypto map set and to use the specified policy during connection or SA negotiation.

Assigning a crypto map to an interface also initializes run-time data structures, such as the SA database and the security policy database. Reassigning a modified crypto map to the interface resynchronizes the run-time data structures with the crypto map configuration. Also, adding new peers through the use of new sequence numbers and reassigning the crypto map does not tear down existing connections.

## Use Interface ACLs

By default, the ASA lets IPsec packets bypass interface ACLs. If you want to apply interface ACLs to IPsec traffic, use the **no** form of the **sysopt connection permit-vpn** command.

The crypto map ACL bound to the outgoing interface either permits or denies IPsec packets through the VPN tunnel. IPsec authenticates and decipheres packets that arrive from an IPsec tunnel, and subjects them to evaluation against the ACL associated with the tunnel.

ACLs define which IP traffic to protect. For example, you can create ACLs to protect all IP traffic between two subnets or two hosts. (These ACLs are similar to ACLs used with the **access-group** command. However, with the **access-group** command, the ACL determines which traffic to forward or block at an interface.)

Before the assignment to crypto maps, the ACLs are not specific to IPsec. Each crypto map references the ACLs and determines the IPsec properties to apply to a packet if it matches a permit in one of the ACLs.

ACLs assigned to IPsec crypto maps have four primary functions:

- Select outbound traffic to be protected by IPsec (permit = protect).
- Trigger an ISAKMP negotiation for data traveling without an established SA.
- Process inbound traffic to filter out and discard traffic that should have been protected by IPsec.
- Determine whether to accept requests for IPsec SAs when processing IKE negotiation from the peer. (Negotiation applies only to **ipsec-isakmp crypto map** entries.) The peer must permit a data flow associated with an **ipsec-isakmp crypto map** command entry to ensure acceptance during negotiation.



---

**Note** If you delete the only element in an ACL, the ASA also removes the associated crypto map.

---

If you modify an ACL currently referenced by one or more crypto maps, use the **crypto map interface** command to reinitialize the run-time SA database. See the **crypto map** command for more information.

We recommend that for every crypto ACL specified for a static crypto map that you define at the local peer, you define a “mirror image” crypto ACL at the remote peer. The crypto maps should also support common transforms and refer to the other system as a peer. This ensures correct processing of IPsec by both peers.



---

**Note** Every static crypto map must define an ACL and an IPsec peer. If either is missing, the crypto map is incomplete and the ASA drops any traffic that it has not already matched to an earlier, complete crypto map. Use the **show conf** command to ensure that every crypto map is complete. To fix an incomplete crypto map, remove the crypto map, add the missing entries, and reapply it.

Crypto ACL does not support duplicate or overlapping entries.

---

We discourage the use of the **any** keyword to specify source or destination addresses in crypto ACLs because they cause problems. We strongly discourage the **permit any any** command statement because it does the following:

- Protects all outbound traffic, including all protected traffic sent to the peer specified in the corresponding crypto map.
- Requires protection for all inbound traffic.

In this scenario, the ASA silently drops all inbound packets that lack IPsec protection.

Ensure that you define which packets to protect. If you use the **any** keyword in a **permit** statement, preface it with a series of **deny** statements to filter out traffic that would otherwise fall within that **permit** statement that you do not want to protect.



---

**Note** Decrypted through traffic is permitted from the client despite having an access group on the outside interface, which calls a deny ip any any access-list, while **no sysopt connection permit-vpn** is configured.

Users who want to control access to the protected network via site-to-site or remote access VPN using the **no sysopt permit** command in conjunction with an access control list (ACL) on the outside interface are not successful.

In this situation, when management-access inside is enabled, the ACL is not applied, and users can still connect using SSH to the security appliance. Traffic to hosts on the inside network are blocked correctly by the ACL, but cannot block decrypted through traffic to the inside interface.

The **ssh** and **http** commands are of a higher priority than the ACLs. In other words, to deny SSH, Telnet, or ICMP traffic to the device from the VPN session, use **ssh**, **telnet** and **icmp** commands, which deny the IP local pool should be added.

---

Regardless of whether the traffic is inbound or outbound, the ASA evaluates traffic against the ACLs assigned to an interface. Follow these steps to assign IPsec to an interface:

### Procedure

---

- Step 1** Create the ACLs to be used for IPsec.
  - Step 2** Map the lists to one or more crypto maps, using the same crypto map name.
  - Step 3** Map the IKEv1 transform sets or IKEv2 proposals to the crypto maps to apply IPsec to the data flows.
  - Step 4** Apply the crypto maps collectively as a crypto map set by assigning the crypto map name they share to the interface.
-

**Example**

In this example, IPsec protection applies to traffic between Host 10.0.0.1 and Host 10.2.2.2 as the data exits the outside interface on ASA A toward Host 10.2.2.2.

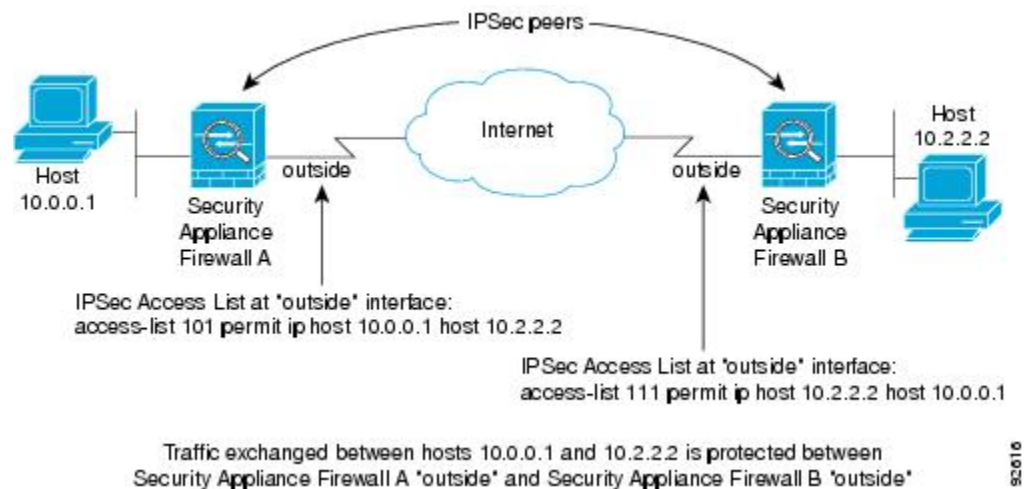

ASA A evaluates traffic from Host 10.0.0.1 to Host 10.2.2.2, as follows:

- source = host 10.0.0.1
- dest = host 10.2.2.2

ASA A also evaluates traffic from Host 10.2.2.2 to Host 10.0.0.1, as follows:

- source = host 10.2.2.2
- dest = host 10.0.0.1

The first permit statement that matches the packet under evaluation determines the scope of the IPsec SA.

**Change IPsec SA Lifetimes**

You can change the global lifetime values that the ASA uses when negotiating new IPsec SAs. You can override these global lifetime values for a particular crypto map.

IPsec SAs use a derived, shared, secret key. The key is an integral part of the SA; the keys time out together to require the key to refresh. Each SA has two lifetimes: timed and traffic-volume. An SA expires after the respective lifetime and negotiations begin for a new one. The default lifetimes are 28,800 seconds (eight hours) and 4,608,000 kilobytes (10 megabytes per second for one hour).

If you change a global lifetime, the ASA drops the tunnel. It uses the new value in the negotiation of subsequently established SAs.

When a crypto map does not have configured lifetime values and the ASA requests a new SA, it inserts the global lifetime values used in the existing SA into the request sent to the peer. When a peer receives a negotiation request, it uses the smaller of either the lifetime value the peer proposes or the locally configured lifetime value as the lifetime of the new SA.

The peers negotiate a new SA before crossing the lifetime threshold of the existing SA to ensure that a new SA is ready when the existing one expires. The peers negotiate a new SA when about 5 to 15 percent of the lifetime of the existing SA remains.



---

**Note** We recommend that you configure different security association timers on either side of the site-to-site IKEv2 tunnel to avoid the rekey collision.

---

## Change VPN Routing

By default, per-packet adjacency lookups are done for the outer ESP packets, lookups are not done for packets sent through the IPsec tunnel.

In some network topologies, when a routing update has altered the inner packet's path, but the local IPsec tunnel is still up, packets through the tunnel may not be routed correctly and fail to reach their destination.

To prevent this, enable per-packet routing lookups for the IPsec inner packets.

### Before you begin

To avoid any performance impact from these lookups, this feature is disabled by default. Enable it only when necessary.

### Procedure

---

Enable per-packet routing lookups for the IPsec inner packets.

**[no] [crypto] ipsec inner-routing-lookup**

**Note** This command, when configured, is only applicable for non-VTI based tunnels.

---

### Example

```
ciscoasa(config)# crypto ipsec inner-routing-lookup
ciscoasa(config)# show run crypto ipsec
crypto ipsec ikev2 ipsec-proposal GCM
protocol esp encryption aes-gcm
protocol esp integrity null
crypto ipsec inner-routing-lookup
```

## Create Static Crypto Maps

To create a basic IPsec configuration using a static crypto map, perform the following steps:

## Procedure

### Step 1

To create an ACL to define the traffic to protect, enter the following command:

```
access-list access-list-name {deny | permit} ip source source-netmask destination destination-netmask
```

The *access-list-name* specifies the ACL ID, as a string or integer up to 241 characters in length. The *destination-netmask* and *source-netmask* specifies an IPv4 network address and subnet mask. In this example, the **permit** keyword causes all traffic that matches the specified conditions to be protected by crypto.

#### Example:

```
hostname(config)# access-list 101 permit ip 10.0.0.0 255.255.255.0 10.1.1.0 255.255.255.0
```

### Step 2

To configure an IKEv1 transform set that defines how to protect the traffic, enter the following command:

```
crypto ipsec ikev1 transform-set transform-set-name encryption [authentication]
```

*Encryption* specifies which encryption method protects IPsec data flows:

- **esp-aes**—Uses AES with a 128-bit key.
- **esp-aes-192**—Uses AES with a 192-bit key.
- **esp-aes-256**—Uses AES with a 256-bit key.
- **esp-null**—No encryption.

*Authentication* specifies which encryption method to protect IPsec data flows:

- **esp-sha-hmac**—Uses the SHA/HMAC-160 as the hash algorithm.
- **esp-none**—No HMAC authentication.

#### Example:

In this example, *myset1* and *myset2* and *aes\_set* are the names of the transform sets.

```
hostname(config)# crypto ipsec ikev1 transform-set myset1 esp-aes esp-sha-hmac
hostname(config)#
hostname(config)# crypto ipsec ikev1 transform-set aes_set esp-md5-hmac esp-aes-256
```

### Step 3

To configure an IKEv2 proposal that also defines how to protect the traffic, enter the following command:

```
crypto ipsec ikev2 ipsec-proposal [proposal tag]
```

*proposal tag* is the name of the IKEv2 IPsec proposal, a string from 1 to 64 characters.

Create the proposal and enter the ipsec proposal configuration mode where you can specify multiple encryption and integrity types for the proposal.

#### Example:

```
hostname(config)# crypto ipsec ikev2 ipsec-proposal secure
```

In this example, *secure* is the name of the proposal. Enter a protocol and encryption types:

```
hostname(config-ipsec-proposal)# protocol esp encryption aes
```

#### Example:

This command chooses which AES-GCM or AES-GMAC algorithm to use:

```
[no] protocol esp encryption [aes| aes-192 | aes-256 | aes-gcm| aes-gcm-192 | aes-gcm-256| null]
```

If SHA-2 or null is chosen, you must choose which algorithm to use as an IPsec integrity algorithm. You must choose the null integrity algorithm if AES-GCM/GMAC is configured as the encryption algorithm:

```
[no] protocol esp integrity [sha-1 | sha-256 | sha-384 | sha-512 | null]
```

**Note** You must choose the null integrity algorithm if AES-GCM/GMAC has been configured as the encryption algorithm. SHA-256 can be used for integrity and PRF to establish IKEv2 tunnels, but it can also be used for ESP integrity protection.

**Step 4** (Optional) An administrator can enable path maximum transfer unit (PMTU) aging and set the interval at which the PMTU value is reset to its original value.

```
[no] crypto ipsec security-association pmtu-aging reset-interval
```

**Step 5** To create a crypto map, perform the following site-to-site steps using either single or multiple context mode:

a) Assign an ACL to a crypto map:

```
crypto map map-name seq-num match address access-list-name
```

A crypto map set is a collection of crypto map entries, each with a different sequence number (*seq-num*) but the same *map name*. Use the *access-list-name* to specify the ACL ID, as a string or integer up to 241 characters in length. In the following example, mymap is the name of the crypto map set. The map set sequence number 10, which is used to rank multiple entries within one crypto map set. The lower the sequence number, the higher the priority.

**Example:**

In this example, the ACL named 101 is assigned to crypto map mymap.

```
crypto map mymap 10 match address 101
```

b) Specify the peer to which the IPsec-protected traffic can be forwarded:

```
crypto map map_name sequence numberset peer ip_address1 [ip_address2] [...]
```

**Example:**

```
crypto map mymap 10 set peer 192.168.1.100
```

The ASA sets up an SA with the peer assigned the IP address 192.168.1.100.

**Note** Beginning with 9.14(1), ASA supports multiple peers in IKEv2 crypto map. You can add a maximum of 10 peers to the list.

c) Specify which IKEv1 transform sets or IKEv2 proposals are allowed for this crypto map. List multiple transform sets or proposals in order of priority (highest priority first). You can specify up to 11 transform sets or proposals in a crypto map using either of these two commands:

```
crypto map map-name seq-num set ikev1 transform-set transform-set-name1 [transform-set-name2, ...transform-set-name11]
```

OR



```
crypto map map-name seq-num set ikev2 ipsec-proposal proposal-name1 [proposal-name2, ... proposal-name11]
```

*Proposal-name1* and *proposal-name11* specifies one or more names of the IPsec proposals for IKEv2. Each crypto map entry supports up to 11 proposals.

**Example:**

In this example for IKEv1, when traffic matches ACL 101, the SA can use either *myset1* (first priority) or *myset2* (second priority) depending on which transform set matches the transform set of the peer.

```
crypto map mymap 10 set ikev1 transform-set myset1 myset2
```

- d) (Optional) For IKEv2, specify the **mode** for applying ESP encryption and authentication to the tunnel. This determines what part of the original IP packet has ESP applied.

```
crypto map map-name seq-num set ikev2 mode [transport | tunnel | transport-require]
```

- **Tunnel mode**—(default) Encapsulation mode will be tunnel mode. Tunnel mode applies ESP encryption and authentication to the entire original IP packet (IP header and data), thus hiding the ultimate source and destination addresses. The entire original IP datagram is encrypted, and it becomes the payload in a new IP packet.

This mode allows a network device, such as a router, to act as an IPsec proxy. That is, the router performs encryption on behalf of the hosts. The source router encrypts packets and forwards them along the IPsec tunnel. The destination router decrypts the original IP datagram and forwards it on to the destination system.

The major advantage of tunnel mode is that the end systems do not need to be modified to receive the benefits of IPsec. Tunnel mode also protects against traffic analysis; with tunnel mode, an attacker can only determine the tunnel endpoints and not the true source and destination of the tunneled packets, even if they are the same as the tunnel endpoints.

- **Transport mode**— Encapsulation mode will be transport mode with option to fallback on tunnel mode, if peer does not support it. In Transport mode only the IP payload is encrypted, and the original IP headers are left intact.

This mode has the advantages of adding only a few bytes to each packet and allowing devices on the public network to see the final source and destination of the packet. With transport mode, you can enable special processing (for example, QoS) on the intermediate network based on the information in the IP header. However, the Layer 4 header is encrypted, which limits examination of the packet.

- **Transport Required**— Encapsulation mode will be transport mode only, falling back to tunnel mode is not allowed.

Where **tunnel** encapsulation mode is the default. **transport** encapsulation mode is transport mode with the option to fallback to tunnel mode if the peer does not support it, and **transport-require** encapsulation mode enforces transport mode only.

**Note** Transport mode is not recommended for Remote Access VPNs.

Examples of negotiation of the encapsulation mode is as follows:

- If the initiator proposes transport mode, and the responder responds with tunnel mode, the initiator will fall back to Tunnel mode.

- If the initiator proposes tunnel mode, and responder responds with transport mode, the responder will fallback to Tunnel mode.
- If the initiator proposes tunnel mode and responder has transport-require mode, then NO PROPOSAL CHOSEN will be sent by the responder.
- Similarly if initiator has transport-require, and responder has tunnel mode, NO PROPOSAL CHOSEN will be sent by the responder.

e) (Optional) Specify an SA lifetime for the crypto map if you want to override the global lifetime.

**crypto map** *map-name seq-num set security-association lifetime* {seconds *number* | kilobytes {*number* | unlimited}}

*Map-name* specifies the name of the crypto map set. *Seq-num* specifies the number you assign to the crypto map entry. You can set both lifetimes based on time or on data transmitted. However, the data transmitted lifetime applies to site-to-site VPN only, it does not apply to remote access VPN.

**Example:**

This example shortens the timed lifetime for the crypto map mymap 10 to 2700 seconds (45 minutes). The traffic volume lifetime is not changed.

```
crypto map mymap 10 set security-association lifetime seconds 2700
```

f) (Optional) Specify that IPsec require perfect forward secrecy when requesting new SA for this crypto map, or require PFS in requests received from the peer:

**crypto map** *map\_name seq-num set pfs* [group14 | group15 | group16 | group19 | group20 | group21]

**Example:**

This example requires PFS when negotiating a new SA for the crypto map mymap 10. The ASA uses the 2048-bit Diffie-Hellman prime modulus group in the new SA.

```
crypto map mymap 10 set pfs group14
```

g) (Optional) Enable Reverse Route Injection (RRI) for any connection based on this crypto map entry.

**crypto map** *map\_name seq-num set reverse-route* [dynamic]

If dynamic is not specified, RRI is done upon configuration and is considered static, remaining in place until the configuration changes or is removed. The ASA automatically adds static routes to the routing table and announces these routes to its private network or border routers using OSPF. Do not enable RRI if you specify any source/destination (0.0.0.0/0.0.0.0) as the protected network, because this will impact traffic that uses your default route.

If dynamic is specified, routes are created upon the successful establishment of IPsec security associations (SA's) and deleted after the IPsec SA's are deleted.

**Note** Dynamic RRI applies to IKEv2 based static crypto maps only.

**Example:**

```
crypto map mymap 10 set reverse-route dynamic
```

**Step 6** Apply a crypto map set to an interface for evaluating IPsec traffic:

**crypto map** *map-name* **interface** *interface-name*

*Map-name* specifies the name of the crypto map set. *Interface-name* specifies the name of the interface on which to enable or disable ISAKMP IKEv1 negotiation.

**Example:**

In this example, the ASA evaluates the traffic going through the outside interface against the crypto map `mymap` to determine whether it needs to be protected.

```
crypto map mymap interface outside
```

---

## Create Dynamic Crypto Maps

A dynamic crypto map is a crypto map without all of the parameters configured. It acts as a policy template where the missing parameters are later dynamically learned, as the result of an IPsec negotiation, to match the peer requirements. The ASA applies a dynamic crypto map to let a peer negotiate a tunnel if its IP address is not already identified in a static crypto map. This occurs with the following types of peers:

- Peers with dynamically assigned public IP addresses.

Both LAN-to-LAN and remote access peers can use DHCP to obtain a public IP address. The ASA uses this address only to initiate the tunnel.

- Peers with dynamically assigned private IP addresses.

Peers requesting remote access tunnels typically have private IP addresses assigned by the headend. Generally, LAN-to-LAN tunnels have a predetermined set of private networks that are used to configure static maps and therefore used to establish IPsec SAs.

As an administrator configuring static crypto maps, you might not know the IP addresses that are dynamically assigned (via DHCP or some other method), and you might not know the private IP addresses of other clients, regardless of how they were assigned. VPN clients typically do not have static IP addresses; they require a dynamic crypto map to allow IPsec negotiation to occur. For example, the headend assigns the IP address to a Cisco VPN client during IKE negotiation, which the client then uses to negotiate IPsec SAs.



---

**Note** A dynamic crypto map requires only the **transform-set** parameter.

---

Dynamic crypto maps can ease IPsec configuration, and we recommend them for use in networks where the peers are not always predetermined. Use dynamic crypto maps for Cisco VPN clients (such as mobile users) and routers that obtain dynamically assigned IP addresses.



---

**Tip** Use care when using the **any** keyword in **permit** entries in dynamic crypto maps. If the traffic covered by such a **permit** entry could include multicast or broadcast traffic, insert **deny** entries for the appropriate address range into the ACL. Remember to insert **deny** entries for network and subnet broadcast traffic, and for any other traffic that IPsec should not protect.

---

Dynamic crypto maps work only to negotiate SAs with remote peers that initiate the connection. The ASA cannot use dynamic crypto maps to initiate connections to a remote peer. With a dynamic crypto map, if

outbound traffic matches a permit entry in an ACL and the corresponding SA does not yet exist, the ASA drops the traffic.

A crypto map set may include a dynamic crypto map. Dynamic crypto map sets should be the lowest priority crypto maps in the crypto map set (that is, they should have the highest sequence numbers) so that the ASA evaluates other crypto maps first. It examines the dynamic crypto map set only when the other (static) map entries do not match.

Similar to static crypto map sets, a dynamic crypto map set consists of all of the dynamic crypto maps with the same dynamic-map-name. The dynamic-seq-num differentiates the dynamic crypto maps in a set. If you configure a dynamic crypto map, insert a permit ACL to identify the data flow of the IPsec peer for the crypto ACL. Otherwise the ASA accepts any data flow identity the peer proposes.



---

**Caution** Do not assign module default routes for traffic to be tunneled to a ASA interface configured with a dynamic crypto map set. To identify the traffic that should be tunneled, add the ACLs to the dynamic crypto map. Use care to identify the proper address pools when configuring the ACLs associated with remote access tunnels. Use Reverse Route Injection to install routes only after the tunnel is up.

---

Create a crypto dynamic map entry using either single or multiple context mode. You can combine static and dynamic map entries within a single crypto map set.

## Procedure

---

**Step 1** (Optional) Assign an ACL to a dynamic crypto map:

**crypto dynamic-map** *dynamic-map-name* *dynamic-seq-num* **match address** *access-list-name*

This determines which traffic should be protected and not protected. *Dynamic-map-name* specifies the name of the crypto map entry that refers to a pre-existing dynamic crypto map. *Dynamic-seq-num* specifies the sequence number that corresponds to the dynamic crypto map entry.

**Example:**

In this example, ACL 101 is assigned to dynamic crypto map dyn1. The map sequence number is 10.

```
crypto dynamic-map dyn1 10 match address 101
```

**Step 2** Specify which IKEv1 transform sets or IKEv2 proposals are allowed for this dynamic crypto map. List multiple transform sets or proposals in order of priority (highest priority first) using the command for IKEv1 transform sets or IKEv2 proposals:

**crypto dynamic-map** *dynamic-map-name* *dynamic-seq-num* **set ikev1 transform-set** *transform-set-name1*, [*transform-set-name2*, ...*transform-set-name9*]

**crypto dynamic-map** *dynamic-map-name* *dynamic-seq-num* **set ikev2 ipsec-proposal** *proposal-name1* [*proposal-name2*, ... *proposal-name11*]

*Dynamic-map-name* specifies the name of the crypto map entry that refers to a pre-existing dynamic crypto map. *Dynamic-seq-num* specifies the sequence number that corresponds to the dynamic crypto map entry. The *transform-set-name* is the name of the transform-set being created or modified. The *proposal-name* specifies one or more names of the IPsec proposals for IKEv2.

**Example:**

In this example for IKEv1, when traffic matches ACL 101, the SA can use either myset1 (first priority) or myset2 (second priority), depending on which transform set matches the transform sets of the peer.

```
crypto dynamic-map dyn 10 set ikev1 transform-set myset1 myset2
```

- Step 3** (Optional) Specify the SA lifetime for the crypto dynamic map entry if you want to override the global lifetime value:

```
crypto dynamic-map dynamic-map-name dynamic-seq-num set security-association lifetime {seconds number | kilobytes {number | unlimited}}
```

*Dynamic-map-name* specifies the name of the crypto map entry that refers to a pre-existing dynamic crypto map. *Dynamic-seq-num* specifies the sequence number that corresponds to the dynamic crypto map entry. You can set both lifetimes based on time or on data transmitted. However, the data transmitted lifetime applies to site-to-site VPN only, it does not apply to remote access VPN.

**Example:**

This example shortens the timed lifetime for dynamic crypto map dyn1 10 to 2700 seconds (45 minutes). The time volume lifetime is not changed.

```
crypto dynamic-map dyn1 10 set security-association lifetime seconds 2700
```

- Step 4** (Optional) Specify that IPsec ask for PFS when requesting new SAs for this dynamic crypto map, or should demand PFS in requests received from the peer:

```
crypto dynamic-map dynamic-map-name dynamic-seq-num set
pfs [group14 | group15 | group16 | group19 | group20 | group21]
```

*Dynamic-map-name* specifies the name of the crypto map entry that refers to a pre-existing dynamic crypto map. *Dynamic-seq-num* specifies the sequence number that corresponds to the dynamic crypto map entry.

**Example:**

```
crypto dynamic-map dyn1 10 set pfs group14
```

- Step 5** Add the dynamic crypto map set into a static crypto map set.

Be sure to set the crypto maps referencing dynamic maps to be the lowest priority entries (highest sequence numbers) in a crypto map set.

```
crypto map map-name seq-num ipsec-isakmp dynamic dynamic-map-name
```

*Map-name* specifies the name of the crypto map set. *Dynamic-map-name* specifies the name of the crypto map entry that refers to a pre-existing dynamic crypto map.

**Example:**

```
crypto map mymap 200 ipsec-isakmp dynamic dyn1
```

## Provide Site-to-Site Redundancy

You can define multiple IKEv1 peers by using crypto maps to provide redundancy. This configuration is useful for site-to-site VPNs. This feature is not supported with IKEv2.

If one peer fails, the ASA establishes a tunnel to the next peer associated with the crypto map. It sends data to the peer that it has successfully negotiated with, and that peer becomes the active peer. The active peer is the peer that the ASA keeps trying first for follow-on negotiations until a negotiation fails. At that point the ASA goes on to the next peer. The ASA cycles back to the first peer when all peers associated with the crypto map have failed.

## Managing IPsec VPNs

### Viewing an IPsec Configuration

These are the commands that you can enter in either single or multiple context mode to view information about your IPsec configuration.

**Table 3: Commands to View IPsec Configuration Information**

|                                               |                                                                                                                                                                              |
|-----------------------------------------------|------------------------------------------------------------------------------------------------------------------------------------------------------------------------------|
| <b>show running-configuration crypto</b>      | Displays the entire crypto configuration, including IPsec, crypto maps, dynamic crypto maps, and ISAKMP.                                                                     |
| <b>show running-config crypto ipsec</b>       | Displays the complete IPsec configuration.                                                                                                                                   |
| <b>show running-config crypto isakmp</b>      | Displays the complete ISAKMP configuration.                                                                                                                                  |
| <b>show running-config crypto map</b>         | Displays the complete crypto map configuration.                                                                                                                              |
| <b>show running-config crypto dynamic-map</b> | Displays the dynamic crypto map configuration.                                                                                                                               |
| <b>show all crypto map</b>                    | Displays all of the configuration parameters, including those with default values.                                                                                           |
| <b>show crypto ikev2 sa detail</b>            | Shows the Suite B algorithm support in the Encryption statistics.                                                                                                            |
| <b>show crypto ipsec sa</b>                   | Shows the Suite B algorithm support and the ESPv3 IPsec output in either single or multiple context mode.                                                                    |
| <b>show ipsec stats</b>                       | Shows information about the IPsec subsystem in either single or multiple context mode. ESPv3 statistics are shown in TFC packets and valid and invalid ICMP errors received. |

## Wait for Active Sessions to Terminate Before Rebooting

You can schedule an ASA reboot to occur only when all active sessions have terminated voluntarily. This feature is disabled by default.

Use the **reload** command to reboot the ASA. If you set the **reload-wait** command, you can use the **reload quick** command to override the **reload-wait** setting. The **reload** and **reload-wait** commands are available in privileged EXEC mode; neither includes the **isakmp** prefix.

### Procedure

---

To enable waiting for all active sessions to voluntarily terminate before the ASA reboots, perform the following site-to-site task in either single or multiple context mode:

**crypto isakmp reload-wait**

#### Example:

```
hostname(config)# crypto isakmp reload-wait
```

---

## Alert Peers Before Disconnecting

Remote access or LAN-to-LAN sessions can drop for several reasons, such as an ASA shutdown or reboot, session idle timeout, maximum connection time exceeded, or administrator cut-off.

The ASA can notify qualified peers (in LAN-to-LAN configurations or VPN clients) of sessions that are about to be disconnected. The peer or client receiving the alert decodes the reason and displays it in the event log or in a pop-up pane. This feature is disabled by default.

Qualified clients and peers include the following:

- Security appliances with Alerts enabled
- Cisco VPN clients running Version 4.0 or later software (no configuration required)

To enable disconnect notification to IPsec peers, enter the **crypto isakmp disconnect-notify** command in either single or multiple context mode.

## Clear Security Associations

Certain configuration changes take effect only during the negotiation of subsequent SAs. If you want the new settings to take effect immediately, clear the existing SAs to reestablish them with the changed configuration. If the ASA is actively processing IPsec traffic, clear only the portion of the SA database that the configuration changes affect. Reserve clearing the full SA database for large-scale changes, or when the ASA is processing a small amount of IPsec traffic.

The following table lists commands you can enter to clear and reinitialize IPsec SAs in either single or multiple context mode.

Table 4: Commands to Clear and Reinitialize IPsec SAs

|                                             |                                                                                                        |
|---------------------------------------------|--------------------------------------------------------------------------------------------------------|
| <b>clear configure crypto</b>               | Removes an entire crypto configuration, including IPsec, crypto maps, dynamic crypto maps, and ISAKMP. |
| <b>clear configure crypto ca trustpoint</b> | Removes all trustpoints.                                                                               |
| <b>clear configure crypto dynamic-map</b>   | Removes all dynamic crypto maps. Includes keywords that let you remove specific dynamic crypto maps.   |
| <b>clear configure crypto map</b>           | Removes all crypto maps. Includes keywords that let you remove specific crypto maps.                   |
| <b>clear configure crypto isakmp</b>        | Removes the entire ISAKMP configuration.                                                               |
| <b>clear configure crypto isakmp policy</b> | Removes all ISAKMP policies or a specific policy.                                                      |
| <b>clear crypto isakmp sa</b>               | Removes the entire ISAKMP SA database.                                                                 |

## Clear Crypto Map Configurations

The **clear configure crypto** command includes arguments that let you remove elements of the crypto configuration, including IPsec, crypto maps, dynamic crypto maps, CA trustpoints, all certificates, certificate map configurations, and ISAKMP.

Be aware that if you enter the **clear configure crypto** command without arguments, you remove the entire crypto configuration, including all certificates.

For more information, see the **clear configure crypto** command in the *Cisco Secure Firewall ASA Series Command Reference*.