



Overview

- [Features, on page 1](#)
- [Package Contents, on page 3](#)
- [Serial Number Locations, on page 4](#)
- [Front Panel, on page 6](#)
- [Front Panel LEDs, on page 9](#)
- [Rear Panel, on page 12](#)
- [Rear Panel LEDs, on page 14](#)
- [Power Supply, on page 15](#)
- [Hardware Specifications, on page 17](#)
- [Product ID Numbers, on page 18](#)
- [Power Cord Specifications, on page 19](#)

Features

The Cisco Content Security Management Appliances (SMA) M195, M395, M695, and M695F centralize reporting, tracking, management of quarantined email messages, and web security appliance configuration settings. They also allow automated data backups.

The SMA M195, M395, M695, and M695F support Cisco AsyncOS version 12.5 and later. See [Product ID Numbers, on page 18](#) for a list of field-replaceable product IDs (PIDs) associated with the SMA security management appliances.

The following figures show the Cisco Content Security Appliances.

Figure 1: Cisco Content Security M195 and M395



Figure 2: Cisco Content Security M695 and M695F



The following table lists the features of the SMA M195, M395, M695, and M695F.

Table 1: SMA M195, M395, M695, and M695F Features

Feature	M195	M395	M695	M695F
Form factor	1 RU		2 RU	
Rack mount	Standard 19-inch (48.3 cm) 4-post EIA rack			
Airflow	Front to rear Cold aisle to hot aisle			
Pullout asset card	Displays the serial number			
Grounding holes	Two threaded holes for dual-hole grounding lug Use is optional; the supported AC power supplies have internal grounding, so no additional chassis grounding is required.			
Locking faceplate	Optional			
Unit identification button	On front panel			
Power button	On rear panel			
Processor	Before January 2021: One Intel Xeon 4110 After January 2021: One Intel Xeon 4210	Before January 2021: One Intel Xeon 4116 After January 2021: One Intel Xeon 4216	Before January 2021: Two Intel Xeon 4110 After January 2021: Two Intel Xeon 4210	
Memory	16-GB RAM		32-GB RAM	
RDIMMs Internal component only; not field-replaceable	Before January 2021: One 16-GB DDR4-2400-MHz DIMM After January 2021: One 16-GB DDR4-2933-MHz DIMM		Before January 2021: Two 16-GB DDR4-2400-MHz DIMMs After January 2021: Two 16-GB DDR4-2933-MHz DIMMs	
Management port	One built-in port (DATA 1)	One built-in port (MGMT)		

Feature	M195	M395	M695	M695F
Network ports	One Gigabit Ethernet (DATA 2)	Five Gigabit Ethernet (DATA 1, DATA 2, DATA 3, DATA 4, DATA 5)		One Gigabit Ethernet (DATA 1) Two fiber optic (DATA 2 and DATA 3)
Remote power cycling (RPC)	Accessed through the 1-Gb dedicated port			
USB ports	Two USB 3.0 Type A			
SFP+ ports	No			Two fiber optic
Supported SFP+	—			GLC-SX-MMD (1 Gb) (optional) SFP-10G-SR (10 Gb) (optional)
Serial console port	One 1-Gb RJ-45 serial port running RS-232 (RS-232D TIA-561) Directly connects a computer to the chassis			
AC power supply Note Do not mix power supply type or wattage between models.	One 770-W AC You can order a second power supply for redundancy as 1+1.	Two 770-W AC Hot-swappable and redundant as 1+1	Two 1050-W AC Hot-swappable and redundant as 1+1	
Fans	Six fans for front-to-rear cooling Internal component only; not field-replaceable. If one fan fails, you must send your chassis for return material authorization (RMA).			
Storage	Two 600-GB SAS HDDs RAID 1, hot-swappable	Eight 600-GB SAS HDDs RAID 10, hot-swappable	Sixteen 600-GB SAS HDDs RAID 10, hot-swappable	

Package Contents

The following figure shows the package contents for the SMA M195, M395, M695, and M695F. Note that the contents are subject to change and your exact contents might contain additional or fewer items.

Figure 3: Package Contents

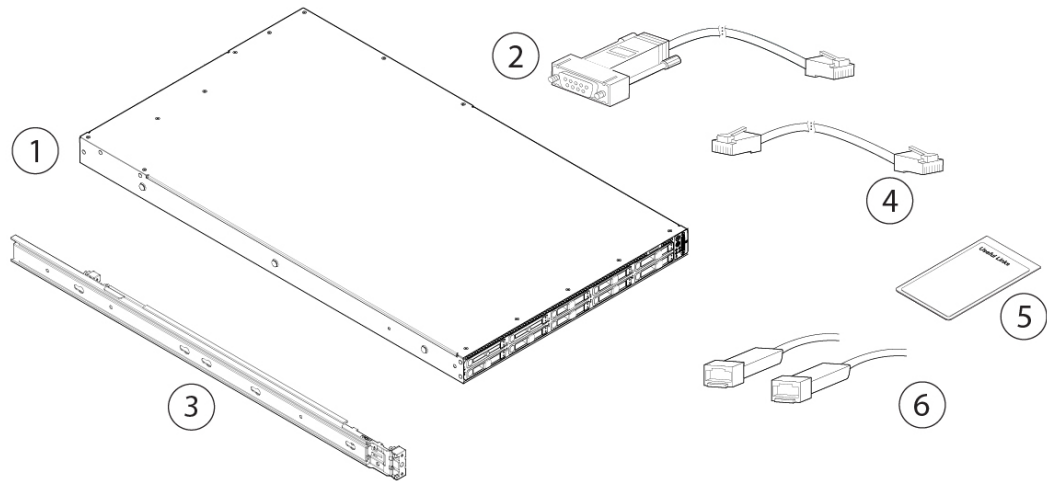

1	Chassis	2	RJ-45 to DB9-RS232 console cable (Cisco part number 72-3383-XX)
3	Cisco rail kit (Cisco part number 800-43376-02)	4	RJ-45 to RJ-45 Cat 5 Ethernet cable, yellow six feet long (Cisco part number 72-1482-XX)
5	Useful Links document The steps in the Useful Links document send you to the documentation you need to install, set up, and configure your SMA appliance.	6	Two 1-Gb or 10-Gb SFP+ fiber optic transceivers with cables Note Supported on the M695F. You cannot mix SFP transceiver types in the same chassis. You can either have two 1-Gb or two 10-Gb SFPs in the same chassis.

Serial Number Locations

The serial number (SN) for the SMA M195, M395, M695, and M695F is printed on the pullout asset card located on the front panel as shown in the following figure.

Figure 4: Serial Number on Pullout Asset Card

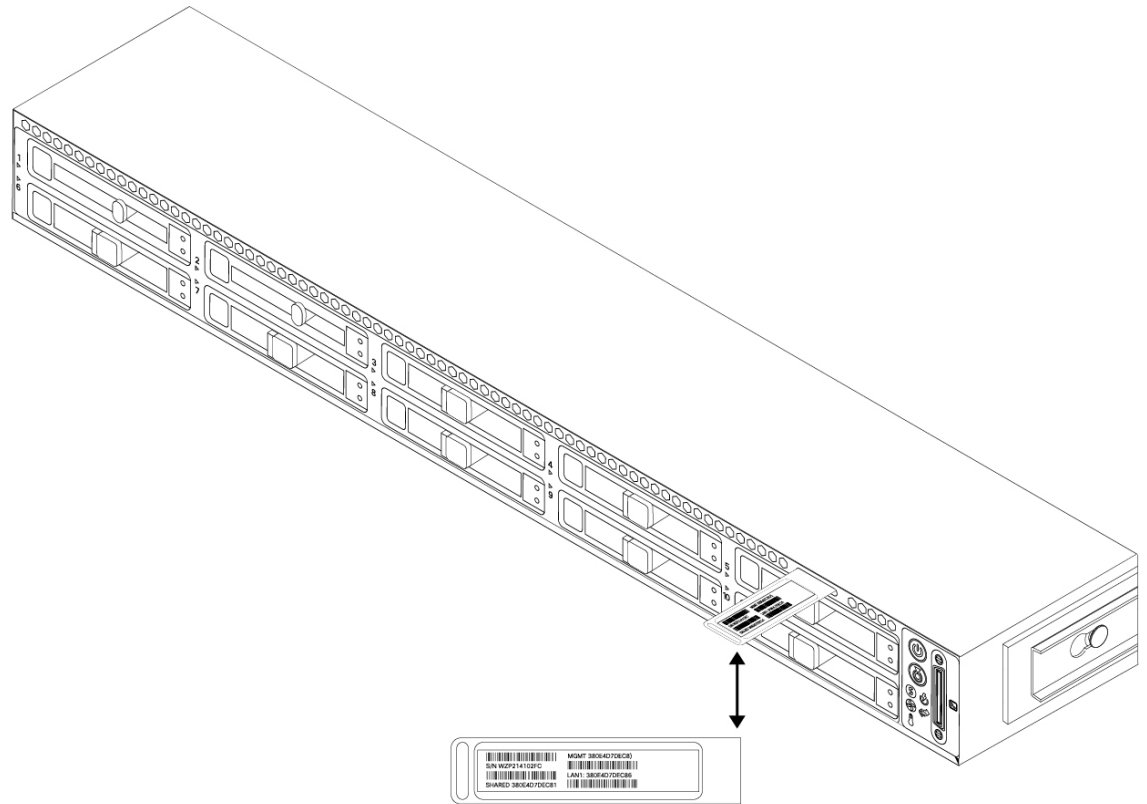

The serial number is also on the label on the cover of the chassis as shown in the following figure.



Caution

The cover latch on the top of the chassis cover is not supported. There are no internal field-replaceable parts in the SMA M195, M395, M695, and M695F.

Figure 5: Serial Number Location on Cover

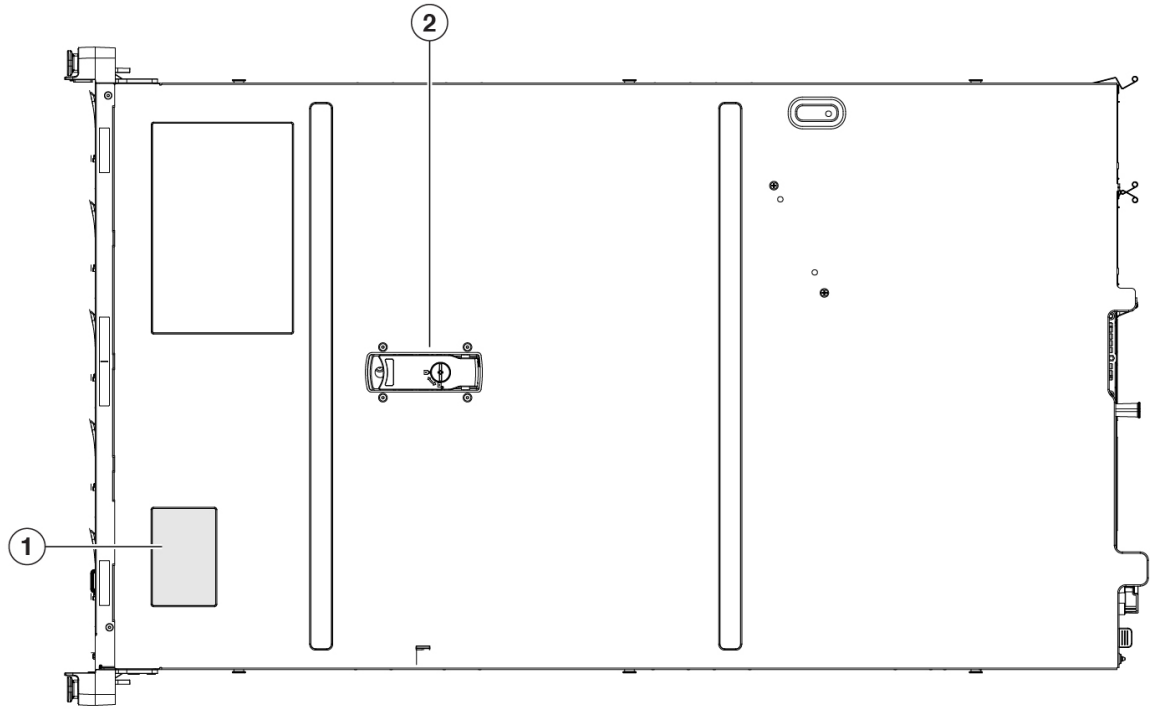

1	Serial number label	2	Cover latch Not supported
---	---------------------	---	------------------------------

Front Panel

The following figure shows the front panel features and disk-drive configuration for the SMA M195. See [Front Panel LEDs, on page 9](#) for a description of the LEDs.

Figure 6: M195 Front Panel

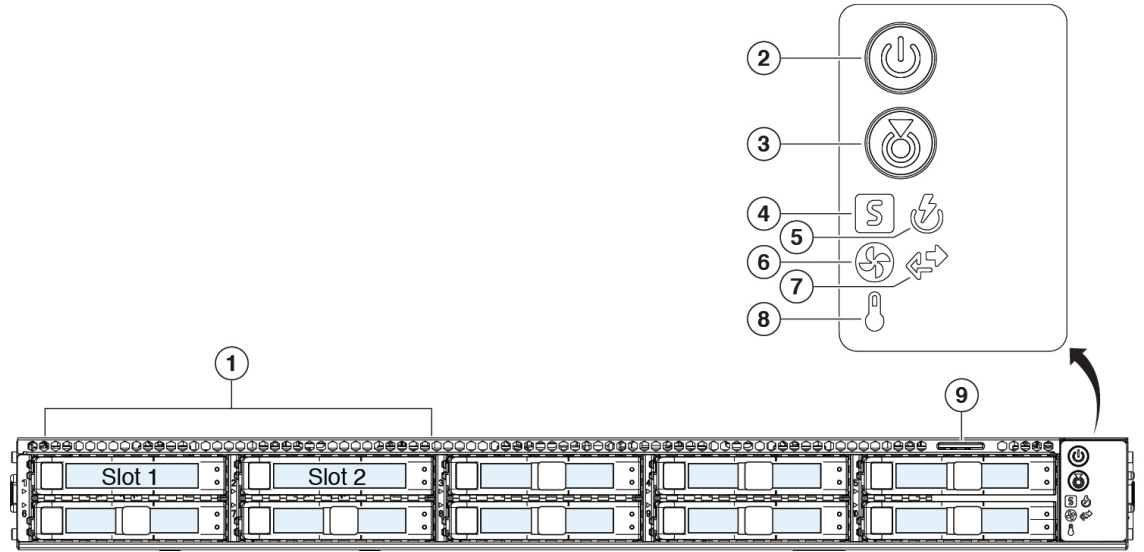

1	Drive bays Supports two 600-GB SAS HDDs in slots 1 and 2	2	Power button/power status LED
3	Unit identification button/LED	4	System status LED
5	Power supply status LED	6	Fan status LED
7	Network link activity LED	8	Temperature status LED
9	Pullout asset card	—	

The following figure shows the front panel features and disk-drive configuration for the SMA M395. See [Front Panel LEDs](#), on page 9 for a description of the LEDs.

Figure 7: M395 Front Panel

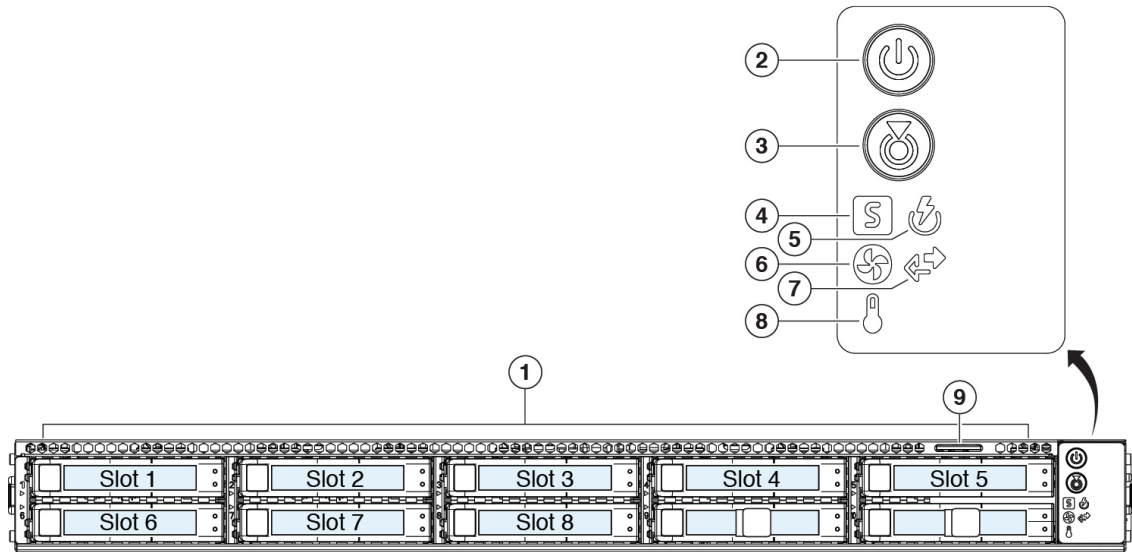

1 Drive bays Supports eight 600-GB SAS HDDs in slots 1 through 8	2 Power button/power status LED
3 Unit identification button/LED	4 System status LED
5 Power supply status LED	6 Fan status LED
7 Network link activity LED	8 Temperature status LED
9 Pullout asset card	—

The following figure shows the front panel features and disk-drive configuration for the SMA M695 and M695F. See [Front Panel LEDs](#), on page 9 for a description of the LEDs.

Figure 8: M695 and M695F Front Panel

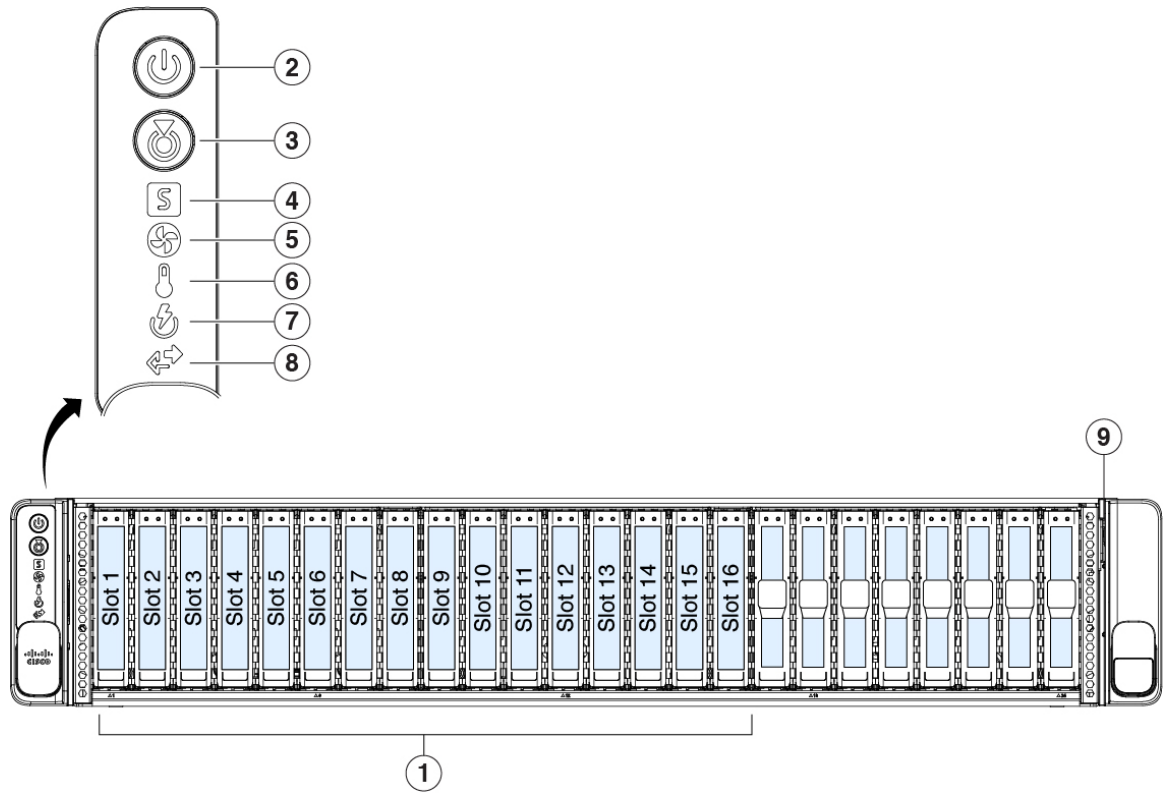

1	Drive bays Supports sixteen 600-GB SAS HDDs in slots 1 through 16	2	Power button/power status LED
3	Unit identification button/LED	4	System status LED
5	Fan status LED	6	Temperature status LED
7	Power supply status LED	8	Network link activity LED
9	Pullout asset card		—

Front Panel LEDs

The following figure shows the front panel LEDs for the M195, M395, M695, and M695F, and describes their states.

Figure 9: Front Panel LEDs and Their States

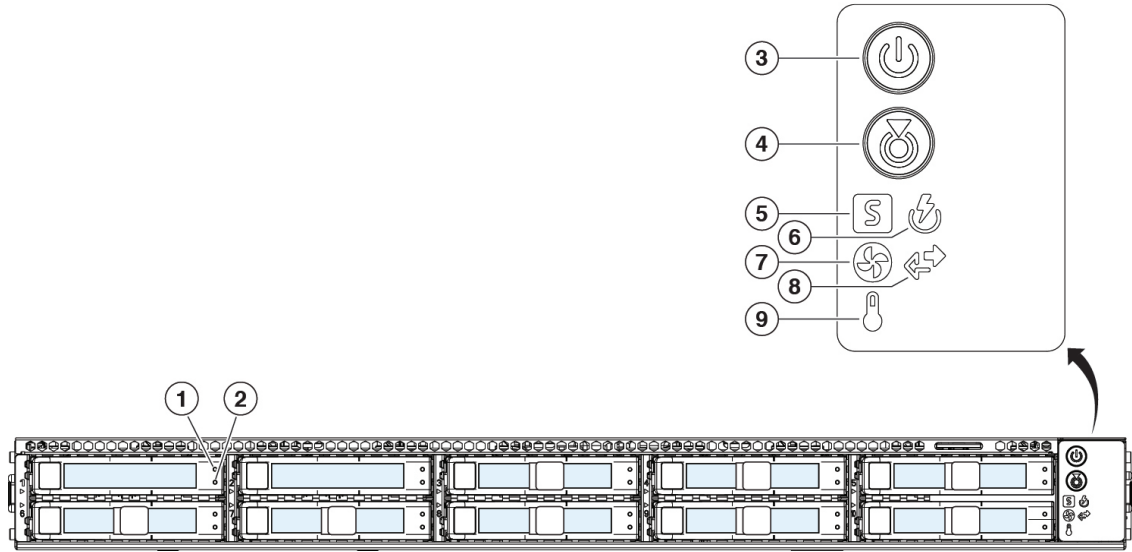

<p>1 Drive fault LED:</p> <ul style="list-style-type: none"> • Off—The drive is operating properly. • Amber—Drive fault detected. • Amber, flashing—The drive is rebuilding. • Amber, flashing with 1-second interval—Drive locate function activated in the software. 	<p>2 Drive activity LED:</p> <ul style="list-style-type: none"> • Off—There is no drive in the drive tray (no access, no fault). • Green—The drive is ready. • Green, flashing—The drive is reading or writing data.
<p>3 Power LED:</p> <ul style="list-style-type: none"> • Off—There is no AC power to the chassis. • Amber—The chassis is in standby mode. • Green—The chassis is in main power mode. Power is supplied to all components. 	<p>4 Unit identification LED:</p> <ul style="list-style-type: none"> • Off—The unit identification function is not in use. • Blue, flashing—The unit identification function is activated.

5	<p>System status LED:</p> <ul style="list-style-type: none"> • Green—The chassis is running in normal operating condition. • Green, flashing—The chassis is performing system initialization and memory check. • Amber—The chassis is in a degraded operational state (minor fault). <ul style="list-style-type: none"> • Power supply redundancy is lost. • CPUs are mismatched. • At least one CPU is faulty. • At least one DIMM is faulty. • At least one drive in a RAID configuration failed. • Amber, 2 flashes—There is a major fault with the system board. • Amber, 3 flashes—There is a major fault with the DIMMs. • Amber, 4 flashes—There is a major fault with the CPUs. 	6	<p>Power supply status LED:</p> <ul style="list-style-type: none"> • Green—All power supplies are operating normally. • Amber—One or more power supplies are in a degraded operational state. • Amber, flashing—One or more power supplies are in a critical fault state.
7	<p>Fan status LED:</p> <ul style="list-style-type: none"> • Green—All fans are operating properly. • Amber, flashing—One or more fans breached the nonrecoverable threshold. 	8	<p>Network link activity LED:</p> <ul style="list-style-type: none"> • Off—The Ethernet port link is idle. • Green—One or more Ethernet ports are link-active, but there is no activity. • Green, flashing—One or more Ethernet ports are link-active with activity.
9	<p>Temperature status LED:</p> <ul style="list-style-type: none"> • Green—The chassis is operating at normal temperature. • Amber—One or more temperature sensors breached the critical threshold. • Amber, flashing—One or more temperature sensors breached the nonrecoverable threshold. 	—	

Rear Panel

The following figure shows the rear panel of the SMA M195. See [Rear Panel LEDs, on page 14](#) for a description of the LEDs.

Figure 10: M195 Rear Panel

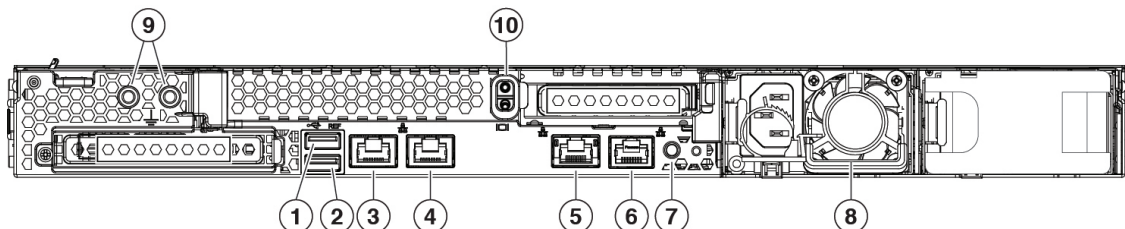

1	USB 3.0 Type A (USB 1)	2	USB 3.0 Type A (USB 2)
3	Management interface (DATA 1)	4	Data interface (DATA 2)
5	RPC port (RPC)	6	Serial console port (Console) RJ-45 connector that directly connects a computer to the appliance.
7	Unit identification button	8	One 770-W AC power supply You can order a second power supply to provide redundancy as 1 + 1.
9	Threaded holes for dual-hole grounding lug Use is optional; the supported AC power supplies have internal grounding, so no additional chassis grounding is required.	10	Riser handle Not supported

The following figure shows the rear panel of the SMA M395. See [Rear Panel LEDs, on page 14](#) for a description of the LEDs.

Figure 11: M395 Rear Panel

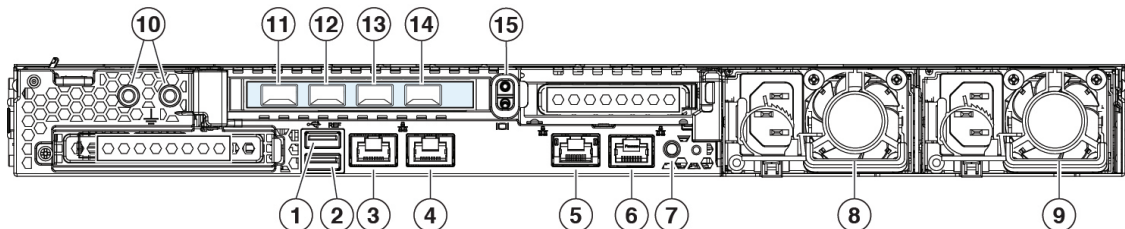

1	USB 3.0 Type A (USB 1)	2	USB 3.0 Type A (USB 2)
3	Management interface (MGMT)	4	Data interface (DATA 5)

5	RPC port (RPC)	6	Serial console port (Console) RJ-45 connector that directly connects a computer to the appliance.
7	Unit identification button	8	770-W AC power supply (PSU 1)
9	770-W AC power supply (PSU 2)	10	Threaded holes for dual-hole grounding lug Use is optional; the supported AC power supplies have internal grounding, so no additional chassis grounding is required.
11	Data interface (DATA 1)	12	Data interface (DATA 2)
13	Data interface (DATA 3)	14	Data interface (DATA 4)
15	Riser handle Not supported		—

The following figure shows the rear panel of the SMA M695. See [Rear Panel LEDs, on page 14](#) for a description of the LEDs.

Figure 12: M695 Rear Panel

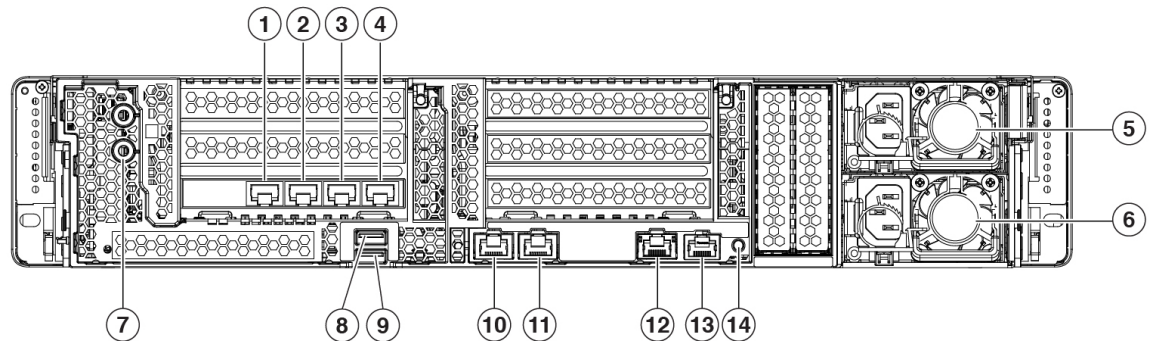

1	Data interface (DATA 1)	2	Data interface (DATA 2)
3	Data interface (DATA 3)	4	Data interface (DATA 4)
5	1050-W AC power supply (PSU1)	6	1050-W AC power supply (PSU 2)
7	Threaded holes for dual-hole grounding lug Use is optional; the supported AC power supplies have internal grounding, so no additional chassis grounding is required.	8	USB 3.0 Type A (USB 1)
9	USB 3.0 Type A (USB 2)	10	Management interface (MGMT)
11	Data interface (DATA 5)	12	RPC port (RPC)

<p>13 Serial console port (Console) RJ-45 connector that directly connects a computer to the appliance.</p>	<p>14 Unit identification button</p>
--	---

The following figure shows the rear panel of the SMA M695F. See [Rear Panel LEDs](#), on page 14 for a description of the LEDs.

Figure 13: M695F Rear Panel

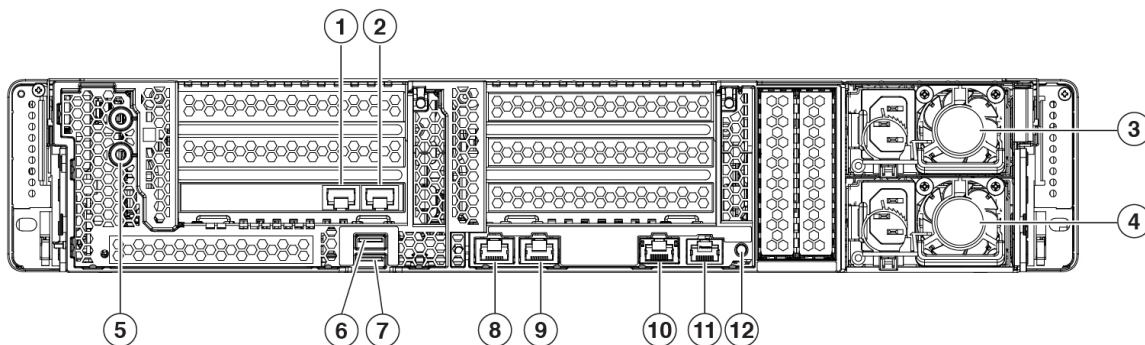

<p>1 Data interface (DATA 2) 1/10-Gigabit SFP+ fiber optic support Use only Cisco-supported SFP+ transceivers.</p>	<p>2 Data interface (DATA 3) 1/10-Gigabit SFP+ fiber optic support Use only Cisco-supported SFP+ transceivers.</p>
<p>3 1050-W AC power supply (PSU 1)</p>	<p>4 1050-W AC power supply (PSU 2)</p>
<p>5 Threaded holes for dual-hole grounding lug Use is optional; the supported AC power supplies have internal grounding, so no additional chassis grounding is required.</p>	<p>6 USB 3.0 Type A (USB 1)</p>
<p>7 USB 3.0 Type A (USB 2)</p>	<p>8 Management interface (MGMT)</p>
<p>9 Data interface (DATA 1)</p>	<p>10 RPC port (RPC)</p>
<p>11 Serial console port (Console) RJ-45 connector that directly connects a computer to the appliance.</p>	<p>12 Unit identification button</p>

Rear Panel LEDs

The following figure shows the rear panel LEDs of the SMA M195 model and describes the LED states. The M395, M695, and M695F have the same LEDs except that these models have more data interfaces; the speed and status LED descriptions are the same.

Figure 14: Rear Panel LEDs and Their States

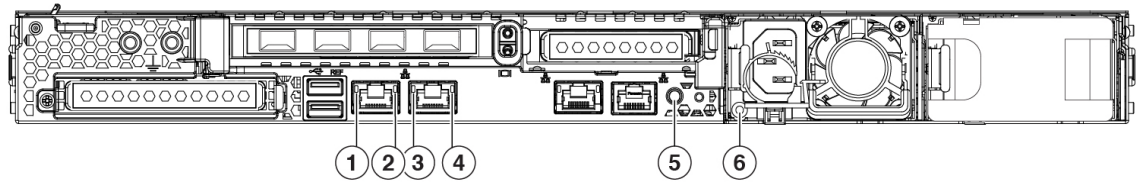

<p>1 Management interface link speed:</p> <ul style="list-style-type: none"> • Off—Link speed is 100 Mbps. • Amber—Link speed is 1 Gbps. • Green—Link speed is 10 Gbps. 	<p>2 Management interface link status:</p> <ul style="list-style-type: none"> • Off—No link is present. • Green—Link is active. • Green, flashing—Traffic is present on the active link.
<p>3 Data interface link speed:</p> <ul style="list-style-type: none"> • Off—Link speed is 10 Mbps. • Amber—Link speed is 100 Mbps. • Green—Link speed is 1 Gbps. 	<p>4 Data interface link status:</p> <ul style="list-style-type: none"> • Off—No link is present. • Green—Link is active. • Green, flashing—Traffic is present on the active link.
<p>5 Rear unit identification:</p> <ul style="list-style-type: none"> • Off—The unit identification function is not in use. • Blue, flashing—The unit identification function is activated. 	<p>6 Power supply (one LED for each power supply):</p> <ul style="list-style-type: none"> • Off—No AC input (12-V main power off; 12-V standby power off) • Green, flashing—12-V main power off; 12-V standby power on. • Green—12-V main power on; 12-V standby power on. • Amber, flashing—Warning threshold detected but 12-V main power on. • Amber—Critical error detected; 12-V main power off (for example, overcurrent, overvoltage, or overtemperature failure).

Power Supply



Note Make sure that one power supply is always active.

The following table lists the specifications for the 770-W AC power supply (Cisco part number 341-0591-04) used in the SMA M195 and M395.

Table 2: 770-W Power Supply Specifications

Description	Specification
AC input voltage range	Nominal range: 100 to 120 V AC, 200 to 240 V AC Range: 90–132 V AC, 180–264 V AC
AC input frequency	Nominal range: 50–60 Hz Range: 47–63 Hz
Maximum AC input current	9.5 A peak at 100-V AC 4.5 A peak at 208 V AC
Maximum input volt amperes	950 VA at 100 V AC
Maximum output power for each power supply	770 W
Maximum inrush current	15 A (subcycle duration)
Maximum hold-up time	12 ms at 770 W
Power supply output voltage	12 V DC
Power supply standby voltage	12 V DC
Efficiency rating	Climate Savers Platinum Efficiency (80 Plus Platinum certified)
Form factor	RSP2
Input connector	IEC320 C13/C15

The following table lists the specifications for the 1050-W AC power supply (Cisco part number 341-0638-03) used in the SMA M695 and 695F.

Table 3: 1050-W Power Supply Specifications

Description	Specification
AC input voltage range	Nominal range: 100 to 120 V AC, 200 to 240 V AC Range: 90–132 V AC, 180–264 V AC
AC input frequency	Nominal range: 50–60 Hz Range: 47–63 Hz
Maximum AC input current	12.5 A peak at 100 V AC 6.0 A peak at 208 V AC
Maximum input volt amperes	1250 VA at 100 V AC

Description	Specification
Maximum output power for each power supply	1050 W
Maximum inrush current	15 A (subcycle duration)
Maximum hold-up time	12 ms at 1050 W
Power supply output voltage	12 V DC
Power supply standby voltage	12 V DC
Efficiency rating	Climate Savers Platinum Efficiency (80 Plus Platinum certified)
Form factor	RSP2
Input connector	IEC320 C13/14/15

Hardware Specifications

The following table lists the hardware specifications for the SMA M195, M395, M695, and M695F.

Table 4: M195, M395, M695, and M695F Hardware Specifications

Specification	M195	M395	M695	M695F
Dimensions (H x W x D)	1.7 x 16.89 x 29.8 inches (4.32 x 43.0 x 75.6 cm)		3.4 x 16.9 x 29.5 inches (8.64 x 42.92 x 74.93 cm)	
Weight	30.5 lbs (13.84 kg)	35.3 lbs (16.01 kg)	51.2 lbs (23.22 kg)	51.4 lbs (23.31 kg)
Temperature	Operating: 41 to 95°F (5 to 35°C) Derate the maximum temperature by 1°C for every 1000 ft (305 m) of altitude above sea level. Nonoperating: -40 to 149°F (-40 to 65°C) When stored or transported			
Relative humidity	Operating: 10 to 90% noncondensing Nonoperating: 5 to 93% noncondensing			
Altitude	Operating: 0 to 10,000 ft Nonoperating: 0 to 40,000 ft When stored or transported			
Sound power level	5.5 Bels (measure A-weighted per ISO7779 LWAd) Operation at 73°F (23°C)			

Specification	M195	M395	M695	M695F
Sound pressure level	40 dBa (measure A-weighted per ISO7779 LpAM)			
	Operation at 73°F (23°C)			

Product ID Numbers

The following table lists the field-replaceable PIDs associated with SMA M195, M395, M695, and M695F. The spare components are ones that you can order and replace yourself. If any internal components fail, you must get an RMA for the entire chassis including the SFPs and SFP cables. Remove the drives and power supplies before you send the chassis for RMA. See the [Cisco Returns Portal](#) for more information.

Table 5: SMA C195, C395, C695, and C695F PIDs

PID	Description
CCS-HDD-600GB10K	SMA M195, M395, M695, M695F HDD
CCS-HDD-600GB10K=	SMA M195, M395, M695, M695F HDD (spare)
CCS-PSU1-770AC	SMA M195 and M395 770 AC power supply
CCS-PSU1-770AC=	SMA M195 and M395 770 AC power supply (spare)
CCS-PSU1-1050AC	SMA M695 and M695F 1050 AC power supply
CCS-PSU1-1050AC=	SMA M695 and M695F 1050 AC power supply (spare)
UCSC-RAILB-M4	SMA M195, M395, M695, and M695F rail kit
UCSC-RAILB-M4=	SMA M195, M395, M695, and M695F rail kit (spare)
UCSC-BZL-C220M5	SMA M195 and M395 1 RU locking faceplate
UCSC-BZL-C220M5=	SMA M195 and M395 1 RU locking faceplate (spare)
UCSC-BZL-C240M5	SMA M695 and M695F 2 RU locking faceplate
UCSC-BZL-C240M5=	SMA M695 and M695F 2 RU locking faceplate (spare)
SFP-10G-SR	ESA C695F 10-Gb SFP
SFP-10G-SR=	ESA C695F 10-Gb SFP (spare)
GLC-SX-MMD	ESA C695F 1-Gb SFP
GLC-SX-MMD=	ESA C695F 1-Gb SFP (spare)

Power Cord Specifications

Each power supply has a separate power cord. Standard power cords or jumper power cords are available for connection to the SMA. The jumper power cords for use in racks are available as an optional alternative to the standard power cords.

If you do not order the optional power cord with the system, you are responsible for selecting the appropriate power cord for the product. Using a incompatible power cord with this product may result in electrical safety hazard. Orders delivered to Argentina, Brazil, and Japan must have the appropriate power cord ordered with the system.

The following power cords and jumper cords are supported.

Figure 15: Argentina CAB-250V-10A-AR

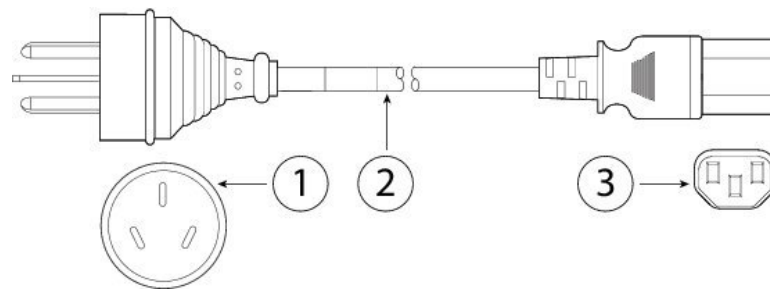

1	Plug: IRAM 2073	2	Cord set rating: 10 A, 250 V
3	Connector: IEC 60320/C13		

Figure 16: Australia CAB-9K10A-AU

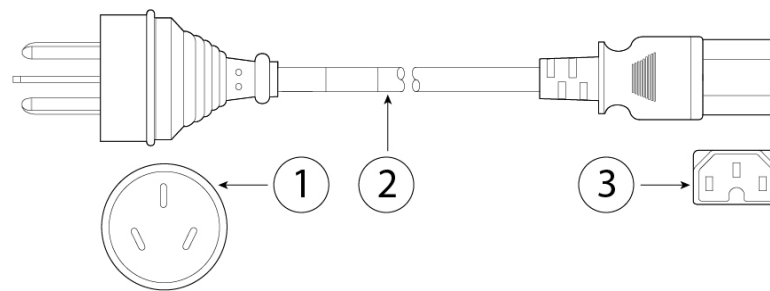

1	Plug: A.S. 3112-2000	2	Cord set rating: 10 A, 250 V
3	Connector: IEC 60320/C15		

Figure 17: Brazil PWR-250V-10A-BZ

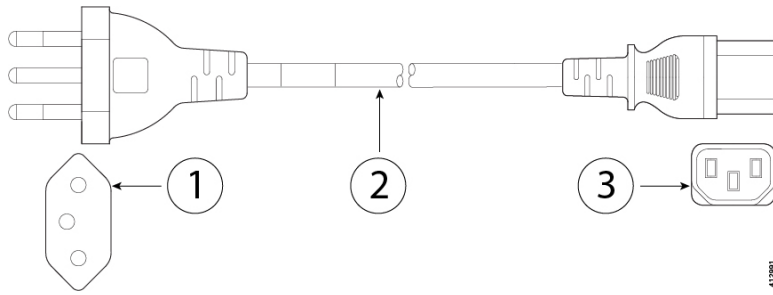

1	Plug: NBR 14136	2	Cord set rating: 10 A, 250 V
3	Connector: IEC 60320/C13		

Figure 18: Cabinet Jumper CAB-C13-C14-2M

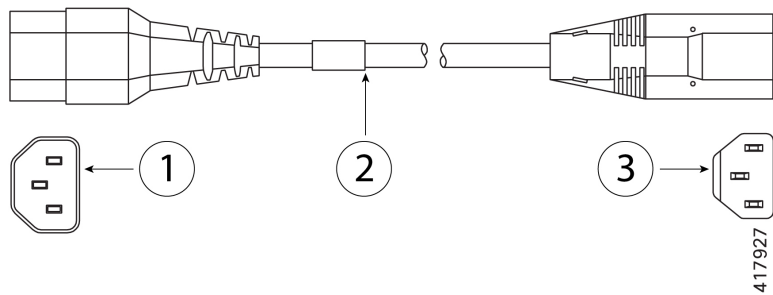

1	Plug: SS10A	2	Cord set rating: 10A, 250V
3	Connector: HS10S, C-13 to C-14		

Figure 19: Cabinet Jumper CAB-C13-C14-AC

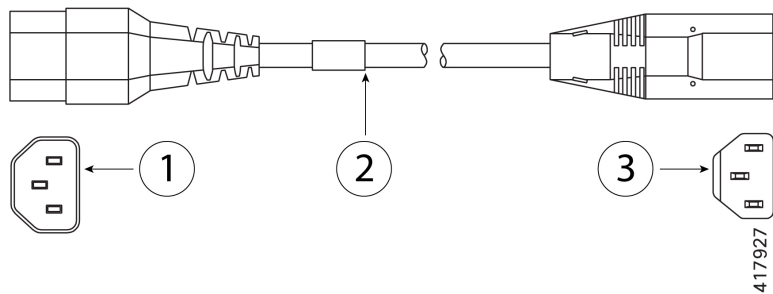

1	Plug: SS10A	2	Cord set rating: 10 A, 250 V
3	Connector: HS10S, C-13 to C-14 (recessed receptacle)		

Figure 20: Cabinet Jumper CAB-C13-CBN

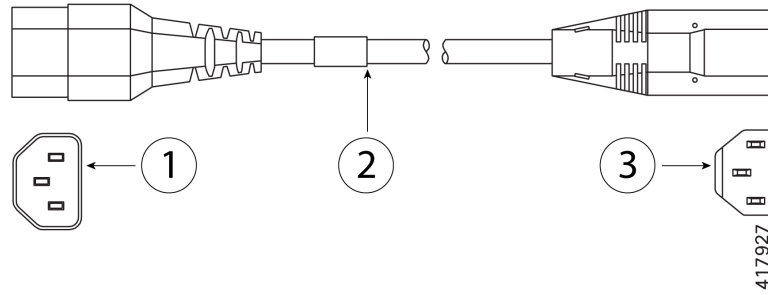

1	Plug: SS10A	2	Cord set rating: 10 A, 250 V
3	Connector: HS10S, C-13 to C-14		

Figure 21: China CAB-250V-10A-CH

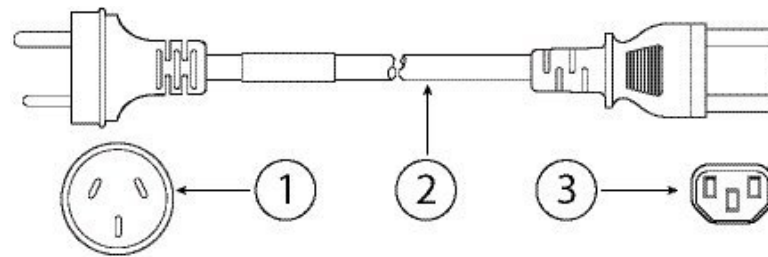

1	Plug: GB2099.1/2008	2	Cord set rating: 10 A, 250 V
3	Connector: IEC 60320/C13		

Figure 22: Europe CAB-9K10A-EU

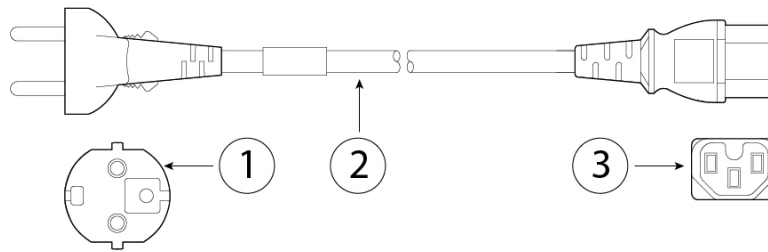

1	Plug: CEE 7/7 (M2511)	2	Cord set rating: 10 A/16 A, 250 V
3	Connector: IEC 60320/C15 (VSCC 15)		

Figure 23: India CAB-250V-10A-ID

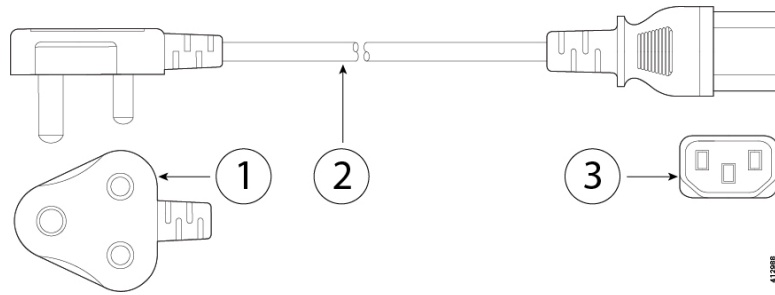

1	Plug: IS 6538-1971	2	Cord set rating: 16 A, 250 V
3	Connector: IEC 60320-C13		

Figure 24: Israel CAB-250V-10A-IS

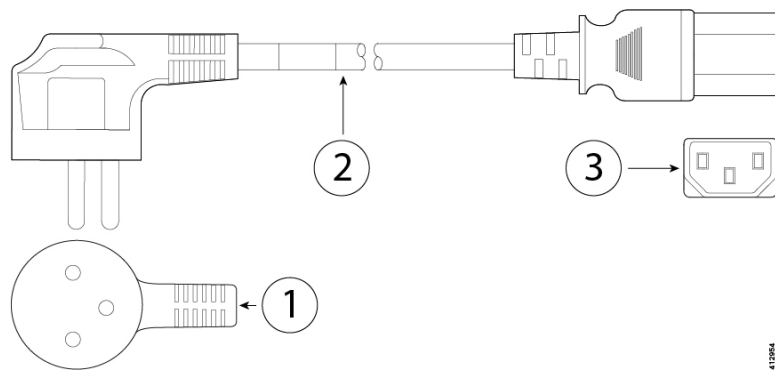

1	Plug: SI-32	2	Cord set rating: 10 A, 250 V
3	Connector: IEC 60320-C13		

Figure 25: Italy CAB-9K10A-IT

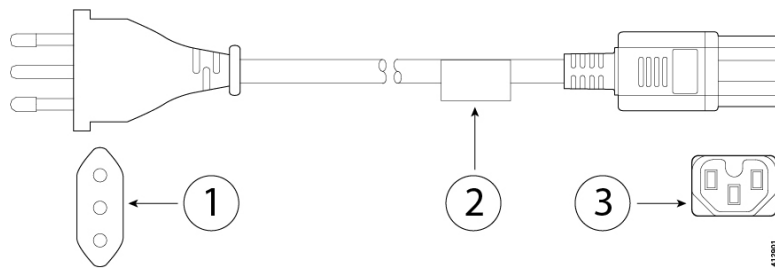

1	Plug: CEI 23-16/VII (I/3G)	2	Cord set rating: 10 A, 250 V
3	Connector: IEC 60320/C15 (EN 60320/C15M)		

Figure 26: Japan CAB-JPN-3PIN

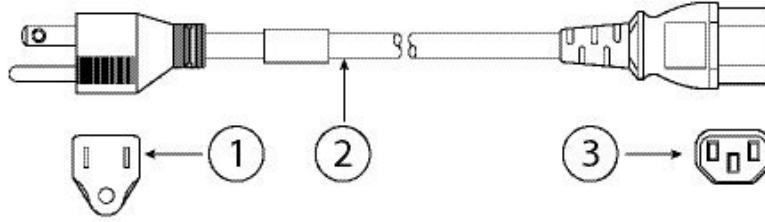

1	Plug: JIS 8303	2	Cord set rating: 12 A, 125 V
3	Connector: IEC 60320/C13		

Figure 27: Japan CAB-C13-C14-2M-JP

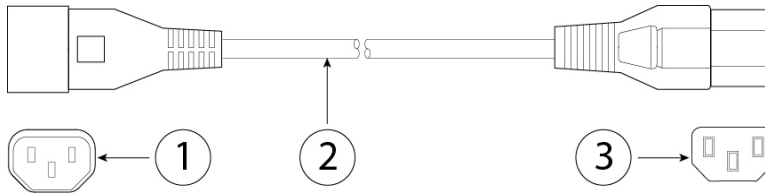

1	Plug: EN 60320-2-2/E	2	Cord set rating: 10 A, 250 V
3	Connector: EN 60320/C13 to C14		

Figure 28: Korea CAB-9K10S-KOR

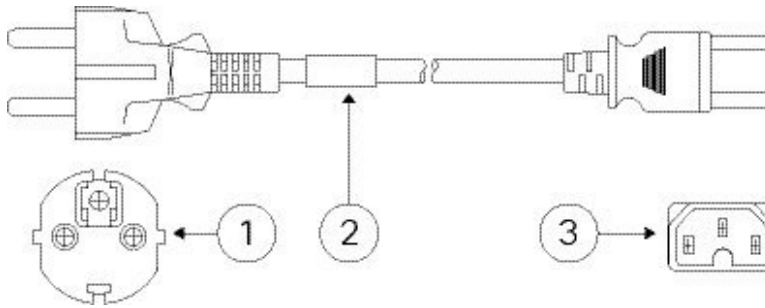

1	Plug: EL211 (KSC 8305)	2	Cord set rating: 10 A, 250 V
3	Connector: IEC 60320/C15		

Figure 29: North America CAB-9K12A-NA

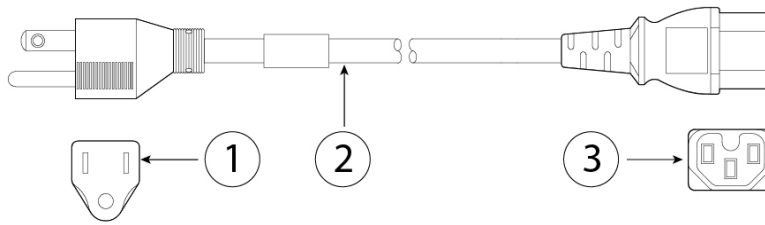

1	Plug: NEMA5-15P	2	Cord set rating: 13 A, 125 V
3	Connector: IEC 60320/C15		

Figure 30: North America CAB-N5K6A-NA

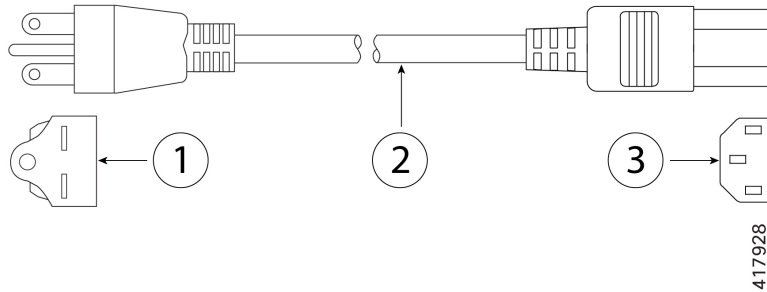

1	Plug: NEMA6-15P	2	Cord set rating: 10 A, 125 V
3	Connector: IEC 60320/C13		

Figure 31: North America CAB-AC-L620-C13

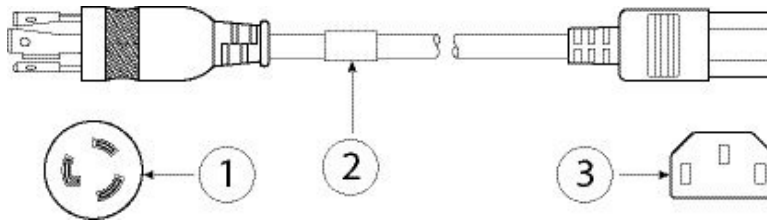

1	Plug: NEMA L6-20 (molded twist lock)	2	Cord set rating: 13 A, 250 V
3	Connector: IEC 60320/C13		

Figure 32: Switzerland CAB-9K10A-SW

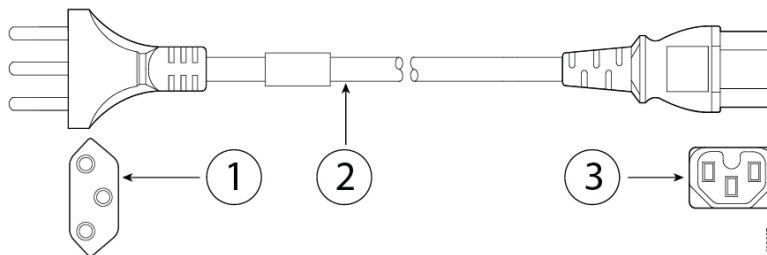

1	Plug: SEV 1011 (MP232-R)	2	Cord set rating: 10 A, 250 V
3	Connector: IEC 60320/C15		

Figure 33: Taiwan CAB-ACTW

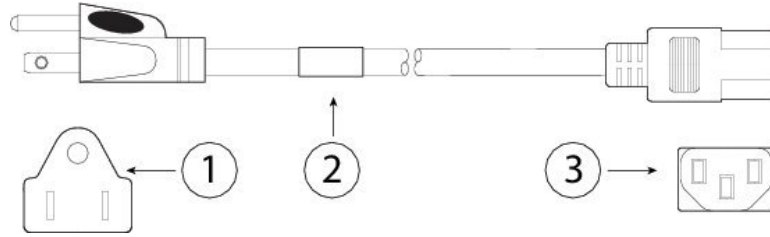

1	Plug: EL 302 (CNS10917)	2	Cord set rating: 10 A, 125 V
3	Connector: IEC 60320/C13		

Figure 34: United Kingdom CAB-9K10A-UK

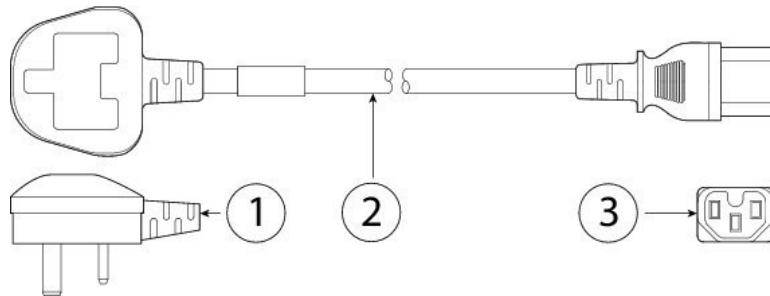

1	Plug: BS1363A/SS145	2	Cord set rating: 10 A, 250 V
3	Connector: IEC 60320/C15		

