



## Hardware Specifications

---

The FireSIGHT System is delivered on a variety of appliances to meet the needs of your organization. See the [Rack and Cabinet Mounting Options, page 7-1](#) for information on installing the appliance in a rack.



**Note**

---

See the ASA documentation for information on hardware specifications for ASA FirePOWER devices.

---

The hardware specifications for each of the appliances are described in the following sections:

- [Defense Centers, page 7-1](#)
- [7000 Series Devices, page 7-20](#)
- [8000 Series Devices, page 7-40](#)

## Rack and Cabinet Mounting Options

You can mount FireSIGHT System appliances in racks and server cabinets. The appliance comes with a rack-mounting kit except for the 3D7010, 3D7020, 3D7030, and 3D7050. For information on mounting the appliance in a rack, refer to the instructions delivered with the rack-mounting kit.

The 3D7010, 3D7020, 3D7030, and 3D7050 require a tray and rack-mounting kit, available separately. You can purchase rack and cabinet mounting kits for other appliances separately.

## Defense Centers

See the following sections for more information about your Defense Center:

- [DC750, page 7-1](#)
- [DC1500, page 7-6](#)
- [DC3500, page 7-10](#)
- [DC4000, page 7-14](#)

### DC750

The DC750 is a 1U appliance. See the following sections for more information about the appliance:

- DC750 Chassis Front View, page 7-2
- DC750 Chassis Rear View, page 7-4
- DC750 Physical and Environmental Parameters, page 7-5

## DC750 Chassis Front View

The front of the DC750 chassis contains the front panel controls.

**Figure 7-1** DC750

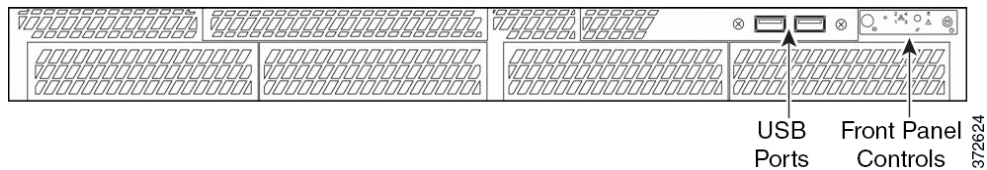

The following diagram illustrates the front panel controls and LEDs for the DC750. The hard disk drive and system status icons, the numbers for the NIC (1, 2, 3, and 4) activity status, and the power button are also the LEDs.

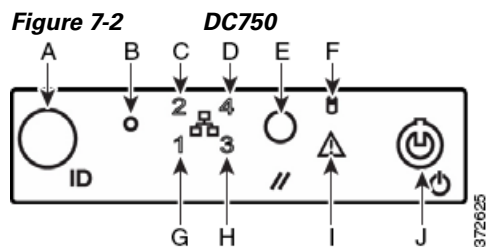

**Table 7-1** Front Panel Components

A	ID button with ID LED	F	Hard disk drive status LED
B	Non-maskable interrupt button	G	NIC 1 activity status LED
C	NIC 2 activity status LED	H	NIC 3 activity status LED
D	NIC 4 activity status LED	I	System status LED
E	Reset button	J	Power button with power LED

The front panel of the chassis houses five LEDs which you can view to display the system's operating state. The following table describes the LEDs on the front panel.

**Table 7-2 DC750 Front Panel LEDs**

LED	Description
System status	<p>Indicates system status:</p> <ul style="list-style-type: none"> <li>• A green light indicates the system is operating normally.</li> <li>• A blinking green light indicates the system is operating in a degraded condition.</li> </ul> <p>For more information, see <a href="#">Table 7-3 on page 7-4</a>.</p>
Power	<p>Indicates whether the system has power or is sleeping:</p> <ul style="list-style-type: none"> <li>• A green light indicates the system is operating normally.</li> <li>• No light indicates the system is off.</li> <li>• A blinking green light indicates the system is sleeping.</li> </ul> <p>The sleep indication is maintained on standby by the chipset. If the system is powered down without going through BIOS, the state in effect at the time of power off will be restored when the system is powered on until the BIOS clears it. If the system is not powered down normally, it is possible that the power light will be blinking at the same time that the system status light is off due to a failure or configuration change that prevents the BIOS from running.</p>
Hard drive activity	<p>Indicates hard drive activity:</p> <ul style="list-style-type: none"> <li>• A blinking green light indicates the fixed disk drive is active.</li> <li>• No light indicates no drive activity, or the system is powered off or sleeping.</li> </ul> <p>Drive activity is determined from the onboard hard disk controllers. The server board also provides a header giving access to this light for add-in controllers.</p>
NIC activity	<p>Indicates activity between the system and the network:</p> <ul style="list-style-type: none"> <li>• A blinking green light indicates there is activity.</li> <li>• No light indicates there is no activity.</li> </ul>

The following table describes the conditions where the system status LED might be lit.

**Table 7-3 DC750 System Status**

Condition	Description
Critical	Any critical or non-recoverable threshold crossing associated with the following events: <ul style="list-style-type: none"> <li>• temperature, voltage, or fan critical threshold crossing</li> <li>• power subsystem failure</li> <li>• the system is unable to power up due to incorrectly installed processors or processor incompatibility</li> <li>• critical event logging errors, including System Memory Uncorrectable ECC error and fatal/uncorrectable bus errors, such as PCI SERR and PERR</li> </ul>
Non-critical	A non-critical condition is a threshold crossing associated with the following events: <ul style="list-style-type: none"> <li>• temperature, voltage, or fan non-critical threshold crossing</li> <li>• chassis intrusion</li> <li>• Set Fault Indication command from system BIOS; the BIOS may use the command to indicate additional, non-critical status such as system memory or CPU configuration changes</li> </ul>
Degraded	A degraded condition is associated with the following events: <ul style="list-style-type: none"> <li>• one or more processors are disabled by Fault Resilient Boot (FRB) or BIOS</li> <li>• BIOS has disabled or mapped out some of the system memory</li> </ul>

### DC750 Chassis Rear View

The rear of the chassis contains the power supply and connection ports for the DC750.

**Figure 7-3 DC750**

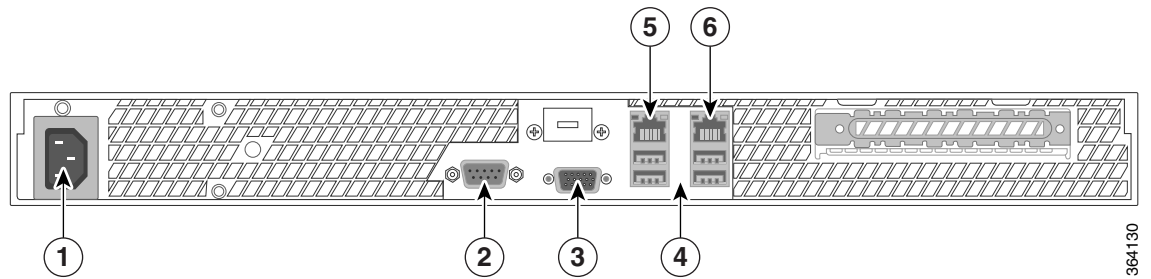

<b>1</b>	Power supply	<b>4</b>	USB ports
<b>2</b>	Serial port	<b>5</b>	Default management interface
<b>3</b>	VGA port	<b>6</b>	Alternate management interface

The following table describes the features that appear on the rear of the appliance.

**Table 7-4 DC750 System Components: Rear View**

Feature	Description
Power supply	Provides power to the Defense Center through an AC power source.
Serial port, VGA port USB ports	Allows you to attach a monitor, keyboard, and mouse to the device.
10/100/1000Mbps Ethernet management interface	Provides for an out-of-band management network connection. The management interface is used for maintenance and configuration purposes <b>only</b> and is not intended to carry service traffic.
Alternate management interface	Provides an alternate interface for the eStreamer client or additional management interface

The 10/100/1000Mbps management interface is located on the rear of the appliance. The following table describes the LEDs associated with the management interface.

**Table 7-5 DC750 Management Interface LEDs**

LED	Description
Left (link)	Indicates whether the link is up: <ul style="list-style-type: none"> <li>• If the light is on, the link is up.</li> <li>• No light indicates there is no link.</li> </ul>
Right (activity)	Indicates activity on the port: <ul style="list-style-type: none"> <li>• A blinking light indicates activity.</li> <li>• No light indicates there is no link.</li> </ul>

## DC750 Physical and Environmental Parameters

The following table describes the physical attributes and the environmental parameters for the appliance.

**Table 7-6 DC750 Physical and Environmental Parameters**

Parameter	DC750
Form factor	1U
Dimensions (D x W x H)	21.8 in. x 17.25 in. x 1.67 in. (55.37 cm x 43.82 cm x 4.24 cm)
Max weight	33 lbs (15 kg)
Power supply	250 W power supply for 120 VAC 6.0 Ampere maximum at 110 volts, 50/60 Hz 3.0 Ampere maximum at 220 volts, 50/60 Hz
Operating temperature	50°F to 95°F (10°C to 35°C) with the maximum rate of change not to exceed 18°F (10°C) per hour
Non-operating temperature	-40°F to +158°F (-40°C to +70°C)
Non-operating humidity	90%, non-condensing at 95°F (35°C)
Acoustic noise	7 BA in an idle state at typical office ambient temperature (73°F +/- 4°F, 23°C +/- 2°C)
Operating shock	No errors with half a sine wave shock of 2G (with 11 ms duration)

**Table 7-6 DC750 Physical and Environmental Parameters (continued)**

Parameter	DC750
Package shock	Operational after 24 in. (60 cm) free fall although cosmetic damage may be present; chassis weight of 40 to 80 lbs (18 to 36 kg)
ESD	+/- 12 kV for air discharge and 8 K for contact
Airflow	Front to back
System cooling requirements	1660 BTU/hour

## DC1500

The DC1500 is a 1U appliance. See the following sections for more information about the appliance:

- [DC1500 Chassis Front View](#), page 7-6
- [DC1500 Chassis Rear View](#), page 7-8
- [DC1500 Physical and Environmental Parameters](#), page 7-9

### DC1500 Chassis Front View

The front of the chassis contains the hard drives and the front panel controls.

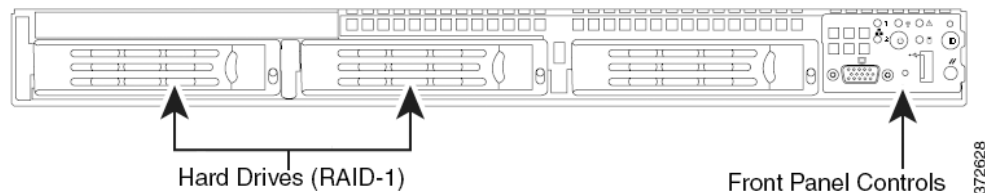

The following diagram illustrates the front panel controls and LEDs.

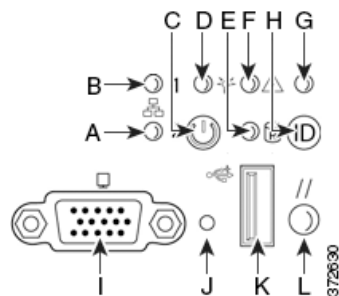
**Table 7-7 Front Panel Components**

A	NIC 2 activity LED	G	ID LED
B	NIC 1 activity LED	H	ID button
C	Power button	I	Video connector (not available)
D	Power/sleep LED	J	Non-maskable interrupt button
E	Fixed disk drive status	K	USB 2.0 connector
F	System status LED	L	Reset button

The front panel of the chassis houses six LEDs, which you can view with or without the front bezel to display the system's operating state. The following table describes the LEDs on the front panel.

**Table 7-8 DC1500 Front Panel LEDs**

LED	Description
NIC 1 activity NIC 2 activity	<p>Indicates activity between the system and the network:</p> <ul style="list-style-type: none"> <li>• A blinking green light indicates activity.</li> <li>• No light indicates no activity.</li> </ul>
Power/sleep	<p>Indicates whether the system has power or is sleeping:</p> <ul style="list-style-type: none"> <li>• A green light indicates the system is operating normally.</li> <li>• A blinking green light indicates the system is sleeping.</li> <li>• No light indicates the system does not have power.</li> </ul> <p>The sleep indication is maintained on standby by the chipset. If the system is powered down without going through BIOS, the state in effect at the time of power off will be restored when the system is powered on until the BIOS clears it. If the system is not powered down normally, it is possible that the power light will be blinking at the same time that the system status light is off due to a failure or configuration change that prevents the BIOS from running.</p>
Hard drive activity	<p>Indicates hard drive activity:</p> <ul style="list-style-type: none"> <li>• A blinking green light indicates the fixed disk drive is active.</li> <li>• An amber light indicates there is a fixed disk drive fault.</li> <li>• No light indicates there is no drive activity, or the system is powered off or sleeping.</li> </ul> <p>Drive activity is determined from the onboard hard disk controllers. The server board also provides a header giving access to this light for add-in controllers.</p>
System status	<p>Indicates system status:</p> <ul style="list-style-type: none"> <li>• A green light indicates the system is operating normally.</li> <li>• A blinking green light indicates the system is operating in a degraded condition.</li> <li>• An amber light indicates the system is in a critical or non-recoverable condition.</li> <li>• A blinking amber light indicates the system is in a non-critical condition.</li> <li>• No light indicates the Power On Self Tests (POST) is underway or the system has stopped.</li> </ul> <p><b>Note</b> The amber status light takes precedence over the green status light. When the amber light is on or blinking, the green light is off.</p> <p>For more information, see <a href="#">Table 7-3 on page 7-4</a>.</p>
System ID	<p>Helps identify a system installed in a high-density rack with other similar systems:</p> <ul style="list-style-type: none"> <li>• A blue light indicates the ID button is pressed and a blue light is on at the rear of the appliance.</li> <li>• No light indicates the ID button is not pressed.</li> </ul>

The following table describes the conditions under which the system status LED might be lit.

**Table 7-9 DC1500 System Status**

Condition	Description
Critical	Any critical or non-recoverable threshold crossing associated with the following events: <ul style="list-style-type: none"> <li>temperature, voltage, or fan critical threshold crossing</li> <li>power subsystem failure</li> <li>the system is unable to power up due to incorrectly installed processors or processor incompatibility</li> <li>critical event logging errors, including System Memory Uncorrectable ECC error and fatal/uncorrectable bus errors, such as PCI SERR and PERR</li> </ul>
Non-critical	A non-critical condition is a threshold crossing associated with the following events: <ul style="list-style-type: none"> <li>temperature, voltage, or fan non-critical threshold crossing</li> <li>chassis intrusion</li> <li>Set Fault Indication command from system BIOS; the BIOS may use the command to indicate additional, non-critical status such as system memory or CPU configuration changes</li> </ul>
Degraded	A degraded condition is associated with the following events: <ul style="list-style-type: none"> <li>one or more processors are disabled by Fault Resilient Boot (FRB) or BIOS</li> <li>BIOS has disabled or mapped out some of the system memory</li> </ul>

### DC1500 Chassis Rear View

The rear of the chassis contains the connection ports and power supply.

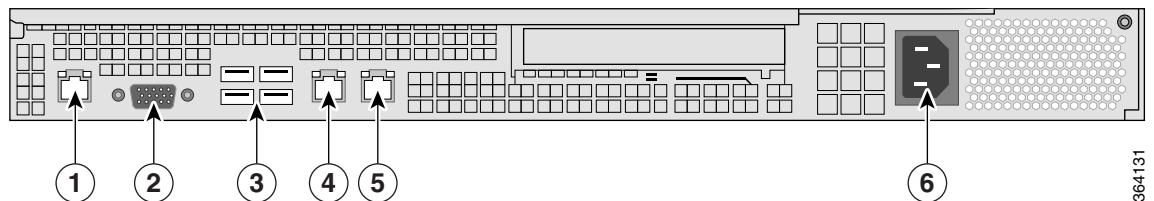

<b>1</b>	Serial port	<b>4</b>	Default management interface
<b>2</b>	VGA port	<b>5</b>	Alternate management interface
<b>3</b>	USB ports	<b>6</b>	Power supply

The following table describes the features that appear on the rear of the appliance.

**Table 7-10 DC1500 System Components: Rear View**

Feature	Description
Power supply	Provides power to the Defense Center through an AC power source.
VGA port USB ports	Allows you to attach a monitor, keyboard, and mouse to the Defense Center.



**Table 7-10 DC1500 System Components: Rear View (continued)**

Feature	Description
10/100/1000Mbps Ethernet management interface	Provides for an out-of-band management network connection. The management interface is used for maintenance and configuration purposes <b>only</b> and is not intended to carry service traffic.
Alternate management interface	Provides an alternate interface for the eStreamer client or additional management interface.
RJ45 serial port	Allows you to establish a direct workstation-to-appliance connection (using an RJ45 to DB-9 adapter) for direct access to all of the management services on the appliance. The RJ45 serial port is used for maintenance and configuration purposes <b>only</b> and is not intended to carry service traffic.  <b>Note</b> You cannot use the front and the rear panel serial ports at the same time.

The 10/100/1000Mbps management interface is located on the rear of the appliance. The following table describes the LEDs associated with the management interface.

**Table 7-11 DC1500 Management Interface LEDs**

LED	Description
Left (link)	Indicates whether the link is up: <ul style="list-style-type: none"> <li>If the light is on, the link is up.</li> <li>No light indicates there is no link.</li> </ul>
Right (activity)	Indicates activity on the port: <ul style="list-style-type: none"> <li>A blinking light indicates activity.</li> <li>No light indicates there is no activity.</li> </ul>

## DC1500 Physical and Environmental Parameters

The following table describes the physical attributes and the environmental parameters for the appliance.

**Table 7-12 DC1500 Physical and Environmental Parameters**

Parameter	Description
Form factor	1U
Dimensions (D x W x H)	27.2 in.x 16.93 in. x 1.7 in. (69.1 cm x 43.0 cm x 4.3 cm)
Max weight	34 lbs (15.4 kg)
Power supply	600 W power supply for 120 VAC 9.5 Ampere maximum at 110 volts, 50/60 Hz 4.75 Ampere maximum at 220 volts, 50/60 Hz
Operating temperature	50°F to 95°F (10°C to 35°C)
Non-operating temperature	-40°F to +158°F (-40°C to +70°C)
Non-operating humidity	90%, non-condensing at 82.4°F (28°C)
Acoustic noise	7 BA (rack mount) in an idle state at typical office ambient temperature (73°F +/- 4°F, 23°C +/- 2°C)

**Table 7-12** DC1500 Physical and Environmental Parameters (continued)

Parameter	Description
Operating shock	No errors with half a sine wave shock of 2G (with 11 ms duration)
Package shock	Operational after 24 in. (60 cm) free fall although cosmetic damage may be present; chassis weight of 40 to 80 lbs (18 to 36 kg)
ESD	+/- 15 kV (I/O port +/-8 KV) per Intel environment test specification
Airflow	Front to back
System cooling requirements	2550 BTU/hour

## DC3500

The DC3500 is a 1U appliance. See the following sections for more information about the appliance:

- [DC3500 Chassis Front View](#), page 7-10
- [DC3500 Chassis Rear View](#), page 7-12
- [DC3500 Physical and Environmental Parameters](#), page 7-14

### DC3500 Chassis Front View

The front of the chassis contains the hard drives and the front panel.

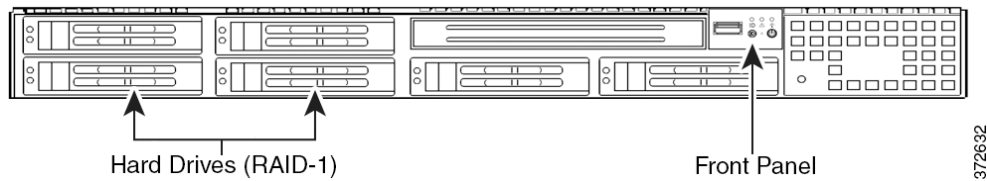

The front of the appliance includes controls and LED displays for the front panel.

The following diagram illustrates the front panel controls and LEDs.

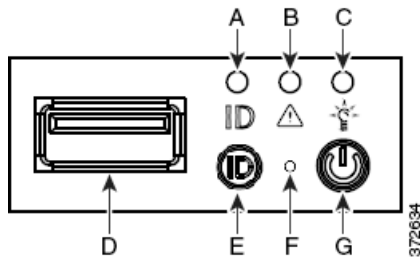
**Table 7-13** Front Panel Components

A	ID LED	E	ID button
B	System status LED	F	Reset button
C	Power LED	G	Power button
D	USB port		

The front panel of the chassis houses three LEDs, which display the system's operating state. The following table describes the LEDs on the front panel.

**Table 7-14** *DC3500 Front Panel LEDs*

LED	Description
Power	<p>Indicates whether the system has power:</p> <ul style="list-style-type: none"> <li>• A green light indicates that the system has power.</li> <li>• No light indicates the system does not have power.</li> </ul>
System status	<p>Indicates the system status:</p> <ul style="list-style-type: none"> <li>• A green light indicates the system is operating normally.</li> <li>• A blinking green light indicates the system is operating in a degraded condition.</li> <li>• A blinking amber light indicates the system is in a non-critical condition.</li> <li>• An amber light indicates the system is in a critical or non-recoverable condition.</li> <li>• No light indicates the system is starting up or off.</li> </ul> <p><b>Note</b> The amber status light takes precedence over the green status light. When the amber light is on or blinking, the green light is off.</p> <p>See <a href="#">Table 7-15 on page 7-12</a> for more information.</p>
Hard drive activity	<p>Indicates the hard drive status:</p> <ul style="list-style-type: none"> <li>• A blinking green light indicates the fixed disk drive is active.</li> <li>• An amber light indicates a fixed disk drive fault.</li> <li>• No light indicates there is no drive activity or the system is powered off.</li> </ul>
NIC activity	<p>Indicates whether there is any network activity:</p> <ul style="list-style-type: none"> <li>• A green light indicates there is network activity.</li> <li>• No light indicates there is no network activity.</li> </ul>
System ID	<p>Helps identify a system installed in a high-density rack with other similar systems:</p> <ul style="list-style-type: none"> <li>• A blue light indicates the ID button is pressed and a blue light is on at the rear of the appliance.</li> <li>• No light indicates the ID button is not pressed.</li> </ul>

The following table describes the conditions under which the system status LED might be lit.

Table 7-15 DC3500 System Status

Condition	Description
Critical	Any critical or non-recoverable threshold crossing associated with the following events: <ul style="list-style-type: none"> <li>temperature, voltage, or fan critical threshold crossing</li> <li>power subsystem failure</li> <li>system inability to power up due to incorrectly installed processors or processor incompatibility</li> <li>critical event logging errors, including System Memory Uncorrectable ECC error and fatal/uncorrectable bus errors, such as PCI SERR and PERR</li> </ul>
Non-critical	A non-critical condition is a threshold crossing associated with the following events: <ul style="list-style-type: none"> <li>temperature, voltage, or fan non-critical threshold crossing</li> <li>chassis intrusion</li> <li>Set Fault Indication command from system BIOS; the BIOS may use the command to indicate additional, non-critical status such as system memory or CPU configuration changes</li> </ul>
Degraded	A degraded condition is associated with the following events: <ul style="list-style-type: none"> <li>one or more processors are disabled by Fault Resilient Boot (FRB) or BIOS</li> <li>some system memory disabled or mapped out by BIOS</li> <li>one of the power supplies unplugged or not functional</li> </ul> <p><b>Tip</b> If you observe a degraded condition indication, check your power supply connections first. Power down the appliance, disconnect both power cords, reconnect the power cords to re-seat them, and then restart the appliance.</p> <p><b>Caution</b>  To power down safely, use the procedure in the Managing Devices chapter in the <i>FireSIGHT System User Guide</i>, or the <code>shutdown -h now</code> command from the Defense Center's shell.</p>

## DC3500 Chassis Rear View

The rear of the chassis contains the connection ports and power supplies.

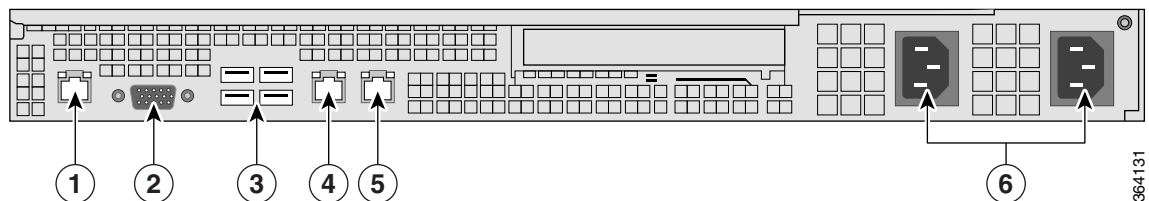

1	Serial port	4	Default management interface
2	VGA port	5	Alternate management interface
3	USB ports	6	Power supplies

The following table describes the features that appear on the rear of the appliance.

**Table 7-16 DC3500 System Components: Rear View**

Feature	Description
PS/2 mouse connector PS/2 keyboard connector VGA port USB ports	Allows you to attach a monitor, keyboard, and mouse to the appliance, as an alternative to using the RJ45 serial port, to establish a direct workstation-to-appliance connection. You also must use a USB port to restore the appliance to its original factory-delivered state, using the thumb drive delivered with the appliance.
RJ45 serial port	Allows you to establish a direct workstation-to-appliance connection (using an RJ45 to DB-9 adapter) for direct access to all of the management services on the appliance. The RJ45 serial port is used for maintenance and configuration purposes <b>only</b> and is not intended to carry service traffic.  <b>Note</b> You cannot use the front and the rear panel serial ports at the same time.
10/100/1000Mbps Ethernet management interface	Provides for an out-of-band management network connection. The management interface is used for maintenance and configuration purposes <b>only</b> and is not intended to carry service traffic.
Alternate management interface	Provides an alternate interface for the eStreamer client or additional management interface.
Redundant power supplies	Provides power to the appliance through an AC power source.

The 10/100/1000Mbps management interface is located on the rear of the appliance. The following table describes the LEDs associated with the management interface.

**Table 7-17 DC3500 Management Interface LEDs**

LED	Description
Left (activity)	Indicates activity on the port: <ul style="list-style-type: none"> <li>• A blinking light indicates activity.</li> <li>• No light indicates there is no activity.</li> </ul>
Right (link)	Indicates whether the link is up: <ul style="list-style-type: none"> <li>• A light indicates the link is up.</li> <li>• No light indicates there is no link.</li> </ul>

The power supply modules are located on the rear of the appliance. The following table describes the LEDs associated with the dual power supplies.

**Table 7-18 DC3500 Power Supply LEDs**

LED	Description
Off	The power supply is not plugged in.
Amber	No power supplied to this module.  or A power supply critical event such as module failure, a blown fuse, or a fan failure; the power supply shuts down.
Blinking amber	A power supply warning event, such as high temperature or a slow fan; the power supply continues to operate.

**Table 7-18 DC3500 Power Supply LEDs (continued)**

LED	Description
Blinking green	AC input is present; volts on standby, the power supply is switched off.
Green	The power supply is plugged in and on.

## DC3500 Physical and Environmental Parameters

The following table describes the physical attributes and the environmental parameters for the appliance.

**Table 7-19 DC3500 Physical and Environmental Parameters**

Parameter	Description
Form factor	1U
Dimensions (D x W x H)	26.2 in. x 16.93 in. x 1.7 in. (66.5 cm x 43.0 cm x 4.3 cm)
Weight	38 lbs (17.2 kg)
Power supply	Dual 650 W redundant power supplies for 120 VAC 8.5 Amp max at 110 volts, 50/60 Hz 4.2 Amp max at 220 volts, 50/60 Hz
Operating temperature	50°F to 95°F (10°C to 35°C)
Non-operating temperature	-40°F to 158°F (-40°C to 70°C)
Operating humidity	5% to 85%
Non-operating humidity	90%, non-condensing at 95°F (35°C)
Acoustic noise	7 BA (rack mount) in an idle state at typical office ambient temperature (73°F +/- 4°F, 23°C +/- 2°C)
Operating shock	No errors with half a sine wave shock of 2G (with 11 ms duration)
Packaged shock	Operational after 24 in. (60 cm) free fall although cosmetic damage may be present; chassis weight of 40 to 80 lbs (18 to 36 kg)
ESD	+/- 15KV (I/O port +/-8KV) per Intel environment test specification
Airflow	Front to back
System cooling requirements	2550 BTU/hr
RoHS	Complies with RoHS Directive 2002/95/EC

## DC4000

The DC4000 is a 1U appliance. See the following sections for more information about the appliance:

- [DC4000 Chassis Front View, page 7-15](#)
- [DC4000 Chassis Rear View, page 7-17](#)
- [DC4000 Physical and Environmental Parameters, page 7-18](#)

## DC4000 Chassis Front View

The front of the chassis contains the hard drives, the front panel, and the KVM connector. The chassis holds up to eight small form-factor (SFF) 2.5-inch solid state drives. The following diagram illustrates the front of the appliance, including the front panel controls and LEDs.

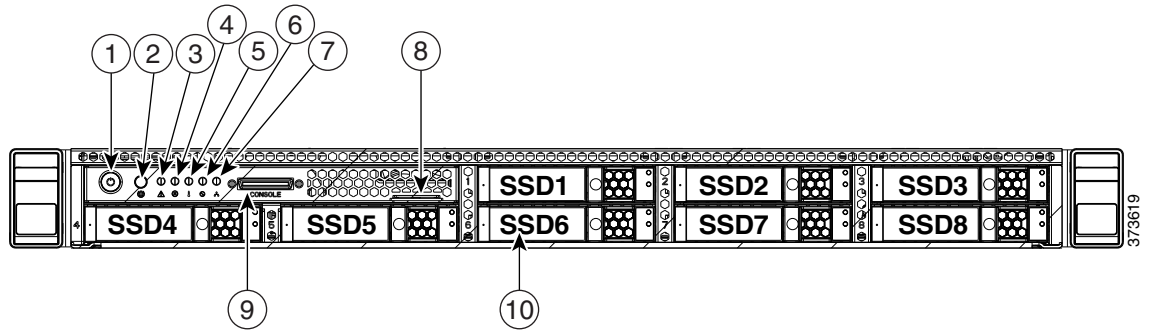

<b>1</b>	Power button/Power status LED	<b>6</b>	Power supply status LED
<b>2</b>	Identification button/LED	<b>7</b>	Network link activity LED
<b>3</b>	System status LED	<b>8</b>	Pull-out asset tag
<b>4</b>	Fan status LED	<b>9</b>	KVM connector (used with KVM cable that provides two USB, one VGA, and one serial connector)
<b>5</b>	Temperature status LED	<b>10</b>	Drives, hot-swappable (up to eight 2.5-inch drives)

The front panel of the chassis houses seven LEDs, which display the system’s operating state. The [DC4000 Front Panel LEDs, Definitions of States](#) table describes the LEDs on the front panel.

**Table 7-20** DC4000 Front Panel LEDs, Definitions of States

LED Name	State
Power button/Power status LED	<ul style="list-style-type: none"> <li>Off—There is no AC power to the server.</li> <li>Amber—The server is in standby power mode. Power is supplied only to the CIMC and some motherboard functions.</li> <li>Green—The server is in main power mode. Power is supplied to all server components.</li> </ul>
Identification	<ul style="list-style-type: none"> <li>Off—The Identification LED is not in use.</li> <li>Blue—The Identification LED is activated.</li> </ul>

Table 7-20 DC4000 Front Panel LEDs, Definitions of States (continued)

LED Name	State
System status	<ul style="list-style-type: none"> <li>• Green—The server is running in normal operating condition.</li> <li>• Green, blinking—The server is performing system initialization and memory check.</li> <li>• Amber, steady—The server is in a degraded operational state. For example: <ul style="list-style-type: none"> <li>– Power supply redundancy is lost.</li> <li>– CPUs are mismatched.</li> <li>– At least one CPU is faulty.</li> <li>– At least one DIMM is faulty.</li> <li>– At least one drive in a RAID configuration failed.</li> </ul> </li> <li>• Amber, blinking—The server is in a critical fault state. For example: <ul style="list-style-type: none"> <li>– Boot failed.</li> <li>– Fatal CPU and/or bus error is detected.</li> <li>– Server is in over-temperature condition.</li> </ul> </li> </ul>
Fan status	<ul style="list-style-type: none"> <li>• Green—All fan modules are operating properly.</li> <li>• Amber, steady—One fan module has failed.</li> <li>• Amber, blinking—Critical fault, two or more fan modules have failed.</li> </ul>
Temperature status	<ul style="list-style-type: none"> <li>• Green—The server is operating at normal temperature.</li> <li>• Amber, steady—One or more temperature sensors have exceeded a warning threshold.</li> <li>• Amber, blinking—One or more temperature sensors have exceeded a critical threshold.</li> </ul>
Power supply status	<ul style="list-style-type: none"> <li>• Green—All power supplies are operating normally.</li> <li>• Amber, steady—One or more power supplies are in a degraded operational state.</li> <li>• Amber, blinking—One or more power supplies are in a critical fault state.</li> </ul>
Network link activity	<ul style="list-style-type: none"> <li>• Off—The Ethernet link is idle.</li> <li>• Green—One or more Ethernet LOM ports are link-active, but there is no activity.</li> <li>• Green, blinking—One or more Ethernet LOM ports are link-active, with activity.</li> </ul>
Hard drive fault	<ul style="list-style-type: none"> <li>• Off—The hard drive is operating properly.</li> <li>• Amber—This hard drive has failed.</li> <li>• Amber, blinking—The device is rebuilding.</li> </ul>
Hard drive activity	<ul style="list-style-type: none"> <li>• Off—There is no hard drive in the hard drive sled (no access, no fault).</li> <li>• Green—The hard drive is ready.</li> <li>• Green, blinking—The hard drive is reading or writing data.</li> </ul>



### DC4000 Chassis Rear View

The rear of the chassis contains the connection ports and power supplies. The appliance provides one 1Gb Ethernet default management interface, two 1Gb Base-T Ethernet ports, one RS-232 serial port (RJ-45 connector), one 15-pin VGA connector, and two USB 2.0 connectors. The following diagram illustrates the rear of the appliance.

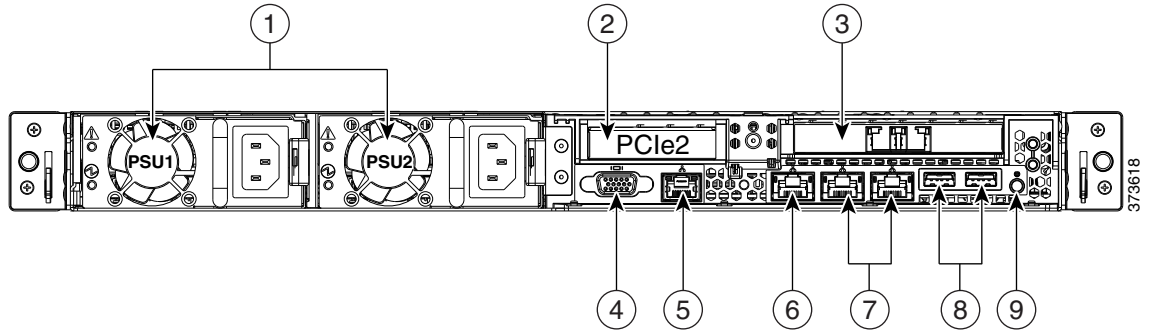

1	Power supplies (two)	6	1Gb Ethernet management interface
2	Low-profile PCIe slot 2 on riser (half-height, half-length, x8 lane)	7	Dual 1-Gb Ethernet ports (LAN1 and LAN2), default management interface is on the left
3	Dual 10-Gb Ethernet ports	8	USB ports
4	VGA video connector	9	Rear Identification button/LED
5	Serial port (RJ-45 connector)		-

The following diagram identifies the LEDs associated with the connection ports and power supplies on the rear of the appliance as well as the system identification button.

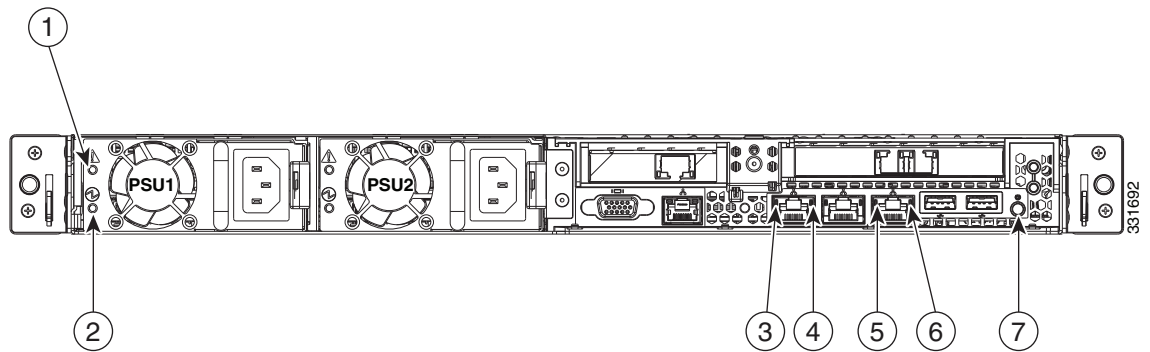

1	Power supply fault LED	5	1Gb Ethernet link speed LED
2	Power supply status LED	6	1Gb Ethernet link status LED
3	1Gb Ethernet default management interface link status LED	7	Rear Identification button/LED
4	1Gb Ethernet default management interface link speed LED		-

The [DC4000 Rear Panel LEDs, Definitions of States](#) table describes the LEDs on the rear of the chassis associated with the default management interface as well as the other connection ports, power supplies, and system identification button located on the rear of the appliance.

**Table 7-21** *DC4000 Rear Panel LEDs, Definitions of States*

LED Name	State
Power supply fault	<ul style="list-style-type: none"> <li>Off—The power supply is operating normally.</li> <li>Amber, blinking—An event warning threshold has been reached, but the power supply continues to operate.</li> <li>Amber, solid—A critical fault threshold has been reached, causing the power supply to shut down (for example, a fan failure or an over-temperature condition).</li> </ul>
Power supply status	<p>AC power supplies:</p> <ul style="list-style-type: none"> <li>Off—There is no AC power to the power supply.</li> <li>Green, blinking—AC power OK, DC output not enabled.</li> <li>Green, solid—AC power OK, DC outputs OK.</li> </ul> <p>DC power supplies:</p> <ul style="list-style-type: none"> <li>Off—There is no DC power to the power supply.</li> <li>Green, blinking—DC power OK, DC output not enabled.</li> <li>Green, solid—DC power OK, DC outputs OK.</li> </ul>
1Gb Ethernet default management interface link speed	<ul style="list-style-type: none"> <li>Off—link speed is 10Mbps.</li> <li>Amber—link speed is 100Mbps.</li> <li>Green—link speed is 1Gbps.</li> </ul>
1Gb Ethernet default management interface link status	<ul style="list-style-type: none"> <li>Off—No link is present.</li> <li>Green—Link is active.</li> <li>Green, blinking—Traffic is present on the active link.</li> </ul>
1Gb Ethernet link speed	<ul style="list-style-type: none"> <li>Off—link speed is 10Mbps.</li> <li>Amber—link speed is 100Mbps.</li> <li>Green—link speed is 1Gbps.</li> </ul>
1Gb Ethernet link status	<ul style="list-style-type: none"> <li>Off—No link is present.</li> <li>Green—Link is active.</li> <li>Green, blinking—Traffic is present on the active link.</li> </ul>
Identification	<ul style="list-style-type: none"> <li>Off—The Identification LED is not in use.</li> <li>Blue—The Identification LED is activated.</li> </ul>

## DC4000 Physical and Environmental Parameters

The following table describes the physical attributes and the environmental parameters for the appliance.

**Table 7-22 DC4000 Physical and Environmental Parameters**

<b>Parameter</b>	<b>Description</b>
Form factor	1U
Dimensions (D x W x H)	28.5 in. x 16.9 in. x 1.7 in. (72.4 cm x 42.9 cm x 4.3 cm)
Weight	35.6 lbs (16.1 kg) maximum (8 SSDs, 2 CPUs, 16 DIMMs, 2 power supplies) 22 lbs (10 kg) bare (0 SSDs, 0 CPUs, 0 DIMMs, 1 power supply)
Power supply	Dual 650 W redundant power supplies  AC input voltage: 90 to 264 VAC self-ranging 100 to 120 VAC nominal 200 to 240 VAC nominal  AC input frequency: 47 to 63 Hz (single phase, 50 to 60 Hz nominal)  Maximum AC input current: 7.6 Amp max at 100 volts 3.65 Amp max at 208 volts  Maximum AC inrush current: 11A  Maximum output power: 650 W  Power Supply output voltage: Main power: 12 VDC Standby power: 12 VDC
Operating temperature	41°F to 104°F (5°C to 40°C) Derate the maximum temperature by 33.8° F (1°C) per every 305 meters of altitude above sea level.
Non-operating temperature	-40°F to 149°F (-40°C to 65°C)
Humidity (RH) non-operating, non-condensing	10% to 90%
Operating altitude	0 to 10,000 ft (0 to 3,000 m)
Non-operating altitude	0 to 40,000 ft (0 to 12,192 m)
Sound power level Measure A-weighted per ISO7779 LwAd (Bels) Operation at 73°F (23°C)	5.4
Sound pressure level Measure A-weighted per ISO7779 LpAm (dBA) Operation at 73°F (23°C)	37
Airflow	Front to rear

## 7000 Series Devices

All 7000 Series Devices have an LCD panel on the front of the appliance where you can view and, if enabled, configure your appliance.

See the following sections for information about your device:

- 3D7010, 3D7020, 3D7030, and 3D7050, page 7-20
- 3D7110 and 3D7120, page 7-25
- 3D7115, 3D7125, and AMP7150, page 7-32

### 3D7010, 3D7020, 3D7030, and 3D7050

The 3D7010, 3D7020, 3D7030, and 3D7050 devices, also called the 70xx Family, are 1U appliances, one-half the width of the rack tray and delivered with eight copper interfaces, each with configurable bypass capability. See the *Regulatory Compliance and Safety Information for FirePOWER and FireSIGHT Appliances* document for safety considerations for 70xx Family appliances.

See the following sections for more information:

- 70xx Family Front View, page 7-20
- 70xx Family Rear View, page 7-24
- 70xx Family Physical and Environmental Parameters, page 7-24

### 70xx Family Front View

The front of the chassis contains the LCD panel, sensing interfaces, front panel, and management interface.

**Figure 7-4** 70xx Family (Chassis: CHRY-1U-AC; NEME-1U-AC) Front View

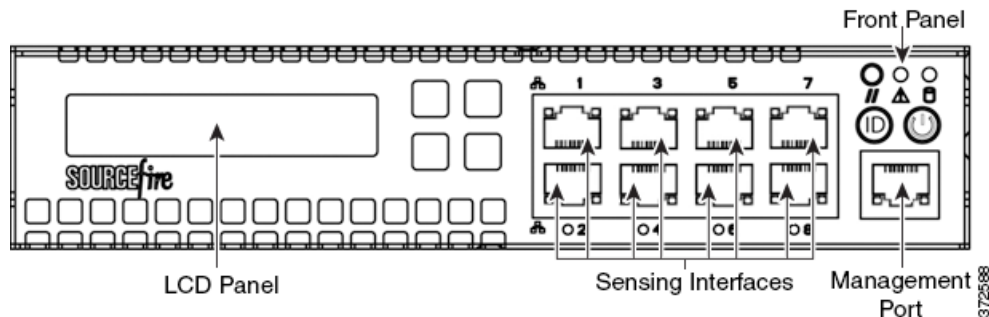

The following table describes the features on the front of the appliance.

**Table 7-23** 70xx Family System Components: Front View

Feature	Description
LCD panel	Operates in multiple modes to configure the device, display error messages, and view system status. For more information, see <a href="#">Using the LCD Panel on a Series 3 Device, page 6-1</a> .
Sensing interfaces	Contain the sensing interfaces that connect to the network. For information, see <a href="#">Sensing Interfaces, page 7-22</a> .

**Table 7-23 70xx Family System Components: Front View (continued)**

Feature	Description
10/100/1000 Ethernet management interface	Provides for an out-of-band management network connection. The management interface is used for maintenance and configuration purposes <b>only</b> and is not intended to carry service traffic.
Front panel	Houses LEDs that display the system’s operating state, as well as various controls, such as the power button. For more information, see <a href="#">Table 7-333D7110 and 3D7120 Front Panel Components, page 7-26</a> .

**Figure 7-5 70xx Family Front Panel**

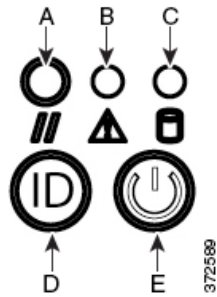

**Table 7-24 Front Panel Components**

A	Reset button	D	System ID button
B	System status LED	E	Power button and LED
C	Hard drive activity LED		

The front panel of the chassis houses LEDs, which display the system’s operating state. The following table describes the LEDs on the front panel.

**Table 7-25 70xx Family Front Panel LEDs**

LED	Description
Reset button	Allows you to reboot the appliance without disconnecting it from the power supply.
System status	Indicates the system status: <ul style="list-style-type: none"> <li>• A green light indicates the system is powered up and operating normally, or powered down and attached to AC power.</li> <li>• An amber light indicates a system fault.</li> </ul> See <a href="#">Table 7-26 on page 7-22</a> for more information.
Hard drive activity	Indicates the hard drive status: <ul style="list-style-type: none"> <li>• A blinking green light indicates the fixed disk drive is active.</li> <li>• If the light is off, there is no drive activity or the system is powered off.</li> </ul>

**Table 7-25** 70xx Family Front Panel LEDs (continued)

LED	Description
System ID	When pressed, the ID button displays a blue light, and a blue light is visible at the rear of the chassis.
Power button and LED	Indicates whether the appliance has power: <ul style="list-style-type: none"> <li>• A green light indicates that the appliance has power and the system is on.</li> <li>• No light indicates the system is shut down or does not have power.</li> </ul>

The following table describes the conditions under which the system status LEDs might be lit.

**Table 7-26** 70xx Family System Status

Condition	Description
Critical	Any critical or non-recoverable threshold crossing associated with the following events: <ul style="list-style-type: none"> <li>• temperature, voltage, or fan critical threshold crossing</li> <li>• power subsystem failure</li> <li>• system inability to power up due to incorrectly installed processors or processor incompatibility</li> <li>• critical event logging errors, including System Memory Uncorrectable ECC error and fatal/uncorrectable bus errors, such as PCI SERR and PERR</li> </ul>
Non-critical	A non-critical condition is a threshold crossing associated with the following events: <ul style="list-style-type: none"> <li>• temperature, voltage, or fan non-critical threshold crossing</li> <li>• Set Fault Indication command from system BIOS; the BIOS may use the command to indicate additional, non-critical status such as system memory or CPU configuration changes</li> </ul>
Degraded	A degraded condition is associated with the following events: <ul style="list-style-type: none"> <li>• one or more processors are disabled by Fault Resilient Boot (FRB) or BIOS</li> <li>• some system memory disabled or mapped out by BIOS</li> <li>• one of the power supplies unplugged or not functional</li> </ul>

## Sensing Interfaces

The 70xx Family appliances are delivered with eight copper interfaces, each with configurable bypass capability.

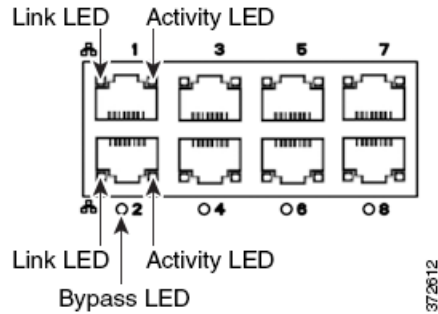
**Figure 7-6** Eight-Port 1000BASE-T Copper Interfaces

Use the following table to understand the activity and link LEDs on the copper interfaces.

**Table 7-27** 70xx Family Copper Link/Activity LEDs

Status	Description
Both LEDs off	The interface does not have link.
Link amber	The speed of the traffic on the interface is 10Mb or 100Mb.
Link green	The speed of the traffic on the interface is 1Gb.
Activity blinking green	The interface has link and is passing traffic.

Use the following table to understand bypass LEDs on the copper interfaces.

**Table 7-28** 70xx Family Copper Bypass LEDs

Status	Description
Off	The interface pair is not in bypass mode or has no power.
Steady green	The interface pair is ready to enter bypass mode.
Steady amber	The interface pair has been placed in bypass mode intentionally, or has entered bypass mode gracefully, and is not inspecting traffic.
Blinking amber	The interface pair has unexpectedly entered bypass mode; that is, it has failed open.

The 10/100/1000 management interface is located on the front of the appliance. The following table describes the LEDs associated with the management interface.

**Table 7-29** 70xx Family Management Interface LEDs

LED	Description	
Left (link)	7010/20/30	Indicates whether the link is up. If the light is on, the link is up. If the light is off, there is no link.
	7050	For 10Mbps links, the link light does not illuminate. Link status is shared with the right (activity) LED.
Right (activity)	7010/20/30	Indicates activity on the port. If the light is blinking, there is activity. If the light is off, there is no activity.
	7050	For 10Mbps links, if the light is on, there is link and activity. If the light is off, there is no link or activity.

## 70xx Family Rear View

The rear of the chassis contains the system ID LED, connection ports, grounding stud, and power supply connector.

**Figure 7-7** 70xx Family (Chassis: CHRY-1U-AC) Rear View

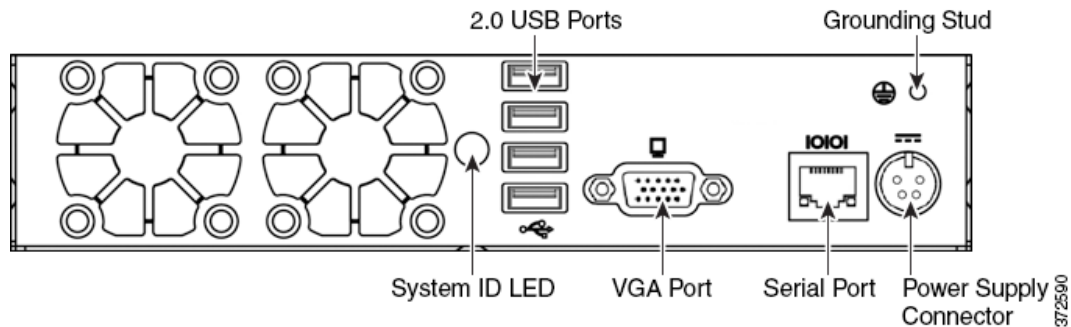

The following table describes the features that appear on the rear of the appliance.

**Table 7-30** 70xx Family System Components: Rear View

Feature	Description
System ID LED	Helps identify a system installed in a high-density rack with other similar systems. The blue LED indicates that the ID button is pressed.
2.0 USB ports VGA port Serial port	Allows you to attach a monitor and keyboard to the device to establish a direct workstation-to-appliance connection.
Grounding stud	Allows you to connect the appliance to the common bonding network. See the <a href="#">Power Requirements for FirePOWER Devices, page A-1</a> for more information.
12V Power supply connector	Provides a power connection to the device through an AC power source.

## 70xx Family Physical and Environmental Parameters

The following table describes the physical attributes and the environmental parameters for the appliance.

**Table 7-31** 70xx Family Physical and Environmental Parameters

Parameter	Description
Form factor	1U, half rack width
Dimensions (D x W x H)	Single chassis: 12.49 in. x 7.89 in. x 1.66 in. (31.74 cm x 20.04 cm x 4.21 cm) 2-Chassis Tray: 25.05 in. x 17.24 in. x 1.73 in. (63.62 cm x 43.8 cm x 4.44 cm)
Chassis weight maximum installed	Chassis: 7 lbs (3.17 kg) Single chassis and power supply in tray: 17.7 lbs (8.03 kg) Double chassis and power supplies in single tray: 24.7 lbs (11.2 kg)
Copper 1000BASE-T	Gigabit copper Ethernet bypass-capable interfaces in a paired configuration Cable and distance: Cat5E at 50 m



**Table 7-31** 70xx Family Physical and Environmental Parameters (continued)

Parameter	Description	
Power supply	200 W AC power supply Voltage: 100 VAC to 240 VAC nominal (90 VAC to 264 VAC maximum) Current: 2A maximum over the full range Frequency range: 50/60 Hz nominal (47 Hz to 63 Hz maximum)	
Operating temperature	7010/20/30	32°F to 104°F (0°C to 40°C)
	7050	23°F to 104°F (-5°C to 40°C)
Non-operating temperature	7010/20/30	-4°F to 158°F (-20°C to 70°C)
	7050	14°F to 140°F (-10°C to 60°C)
Operating humidity	7010/20/30	5% to 95%, non-condensing Operation beyond these limits is not guaranteed and not recommended.
	7050	5% to 85%, non-condensing Operation beyond these limits is not guaranteed and not recommended.
Non-operating humidity	7010/20/30	0% to 95%, non-condensing
	7050	0% to 85%, non-condensing
	Store the unit below the maximum non-condensing relative humidity. Acclimate below maximum operating humidity at least 48 hours prior to placing the unit in service.	
Altitude	0 ft (sea level) to 5905 ft (0 m to 1800 m)	
Cooling requirements	682 BTU/hour You must provide sufficient cooling to maintain the appliance within its required operating temperature range. Failure to do this may cause a malfunction or damage to the appliance.	
Acoustic noise	53 dBA when idle. 62 dBA at full processor load	
Operating shock	No errors with half a sine wave shock of 5G (with 11 ms duration)	
Airflow	20 ft <sup>3</sup> (0.57 m <sup>3</sup> ) per minute Airflow through the appliance enters at the front and sides and exits at the rear.	

## 3D7110 and 3D7120

The 3D7110 and 3D7120 devices, part of the 71xx Family, are 1U appliances, and are delivered with eight copper or eight fiber interfaces, each with configurable bypass capability. See the *Regulatory Compliance and Safety Information for FirePOWER and FireSIGHT Appliances* document for safety considerations for 71xx Family appliances.

See the following sections for more information:

- [3D7110 and 3D7120 Chassis Front View, page 7-26](#)
- [3D7110 and 3D7120 Chassis Rear View, page 7-30](#)
- [3D7110 and 3D7120 Physical and Environmental Parameters, page 7-31](#)

### 3D7110 and 3D7120 Chassis Front View

The front of the chassis contains the LCD panel, USB port, front panel, and either copper or fiber sensing interfaces.

**Figure 7-8** 3D7110 and 3D7120 with Copper Interfaces (Chassis: GERY-1U-8-C-AC)

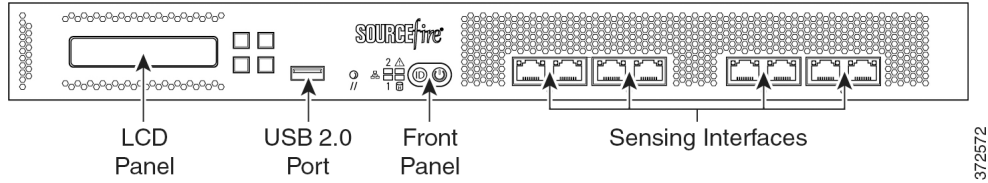

372572

**Figure 7-9** 3D7110 and 3D7120 with Fiber Interfaces (Chassis: GERY-1U-8-FM-AC)

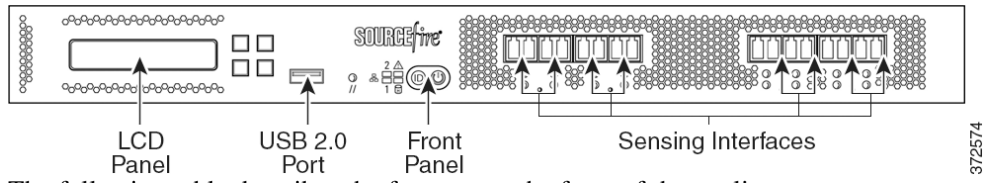

372574

The following table describes the features on the front of the appliance.

**Table 7-32** 3D7110 and 3D7120 System Components: Front View

Feature	Description
LCD panel	Operates in multiple modes to configure the device, display error messages, and view system status. For more information, see <a href="#">Using the LCD Panel on a Series 3 Device, page 6-1</a> .
Front panel USB 2.0 port	Allows you to attach a keyboard to the device.
Front panel	Houses LEDs that display the system’s operating state, as well as various controls, such as the power button. For more information, see <a href="#">Figure 7-103D7110 and 3D7120 Front Panel, page 7-26</a> .
Sensing interfaces	Contain the sensing interfaces that connect to the network. For more information, see <a href="#">3D7110 and 3D7120 Sensing Interfaces, page 7-28</a> .

**Figure 7-10** 3D7110 and 3D7120 Front Panel

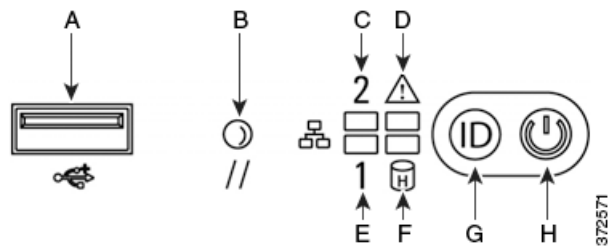

372571

**Table 7-33** 3D7110 and 3D7120 Front Panel Components

A	USB 2.0 connector	E	NIC1 activity LED
B	Reset button	F	Hard drive activity LED

**Table 7-33 3D7110 and 3D7120 Front Panel Components (continued)**

C	NIC2 activity LED	G	ID button
D	System status LED	H	Power button and LED

The front panel of the chassis houses LEDs, which display the system's operating state. The following table describes the LEDs on the front panel.

**Table 7-34 3D7110 and 3D7120 Front Panel LEDs**

LED	Description
NIC activity (1 and 2)	Indicates whether there is any network activity: <ul style="list-style-type: none"> <li>• A green light indicates there is network activity.</li> <li>• No light indicates there is no network activity.</li> </ul>
System status	Indicates the system status: <ul style="list-style-type: none"> <li>• No light indicates the system is operating normally, or is powered off.</li> <li>• A red light indicates a system error.</li> </ul> See the <a href="#">Table 7-353D7110 and 3D7120 System Status, page 7-28</a> for more information.
Reset button	Allows you to reboot the appliance without disconnecting it from the power supply.
Hard drive activity	Indicates the hard drive status: <ul style="list-style-type: none"> <li>• A blinking green light indicates the fixed disk drive is active.</li> <li>• An amber light indicates a fixed disk drive fault.</li> <li>• If the light is off, there is no drive activity or the system is powered off.</li> </ul>
System ID	Helps identify a system installed in a high-density rack with other similar systems: <ul style="list-style-type: none"> <li>• A blue light indicates the ID button is pressed and a blue light is on at the rear of the appliance.</li> <li>• No light indicates the ID button is not pressed.</li> </ul>
Power button and LED	Indicates whether the appliance has power: <ul style="list-style-type: none"> <li>• A green light indicates that the appliance has power and the system is on.</li> <li>• A blinking green light indicates that the appliance has power and is shut down.</li> <li>• If the light is off, the system does not have power.</li> </ul>

The following table describes the conditions under which the system status LEDs might be lit.

Table 7-35 3D7110 and 3D7120 System Status

Condition	Description
Critical	Any critical or non-recoverable threshold crossing associated with the following events: <ul style="list-style-type: none"> <li>temperature, voltage, or fan critical threshold crossing</li> <li>power subsystem failure</li> <li>system inability to power up due to incorrectly installed processors or processor incompatibility</li> <li>critical event logging errors, including System Memory Uncorrectable ECC error and fatal/uncorrectable bus errors, such as PCI SERR and PERR</li> </ul>
Non-critical	A non-critical condition is a threshold crossing associated with the following events: <ul style="list-style-type: none"> <li>temperature, voltage, or fan non-critical threshold crossing</li> <li>chassis intrusion</li> <li>Set fault indication command from system BIOS; the BIOS may use the command to indicate additional non-critical status such as system memory or CPU configuration changes</li> </ul>
Degraded	Any degraded condition is associated with the following events: <ul style="list-style-type: none"> <li>one or more processors are disabled by Fault Resilient Boot (FRB) or BIOS</li> <li>some system memory disabled or mapped out by BIOS</li> <li>one of the power supplies unplugged or not functional</li> </ul> <p><b>Tip</b> If you observe a degraded condition indication, check your power supply connections first. Power down the device, disconnect both power cords, reconnect the power cords to reseal them, then restart the device.</p> <p><b>Caution</b>  To power down safely, use the procedure in the Managing Devices chapter in the <i>FireSIGHT System User Guide</i>, or the <code>system shutdown</code> command from the CLI.</p>

### 3D7110 and 3D7120 Sensing Interfaces

The 3D7110 and 3D7120 devices are delivered with eight-port copper or eight-port fiber interfaces, each with configurable bypass capability.

**Figure 7-11** Eight-Port 100BASE-T Copper Interfaces

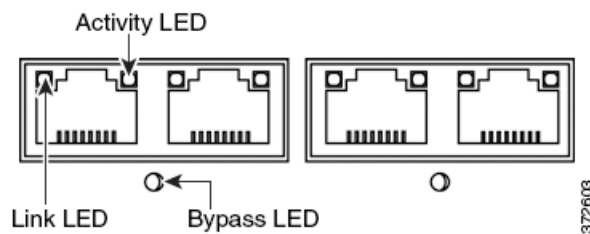

Use the following table to understand the activity and link LEDs on the copper interfaces.

**Table 7-36** 3D7110 and 3D7120 Copper Link/Activity LEDs

Status	Description
Both LEDs off	The interface does not have link.
Link amber	The speed of the traffic on the interface is 10Mb or 100Mb.
Link green	The speed of the traffic on the interface is 1Gb.
Activity blinking green	The interface has link and is passing traffic.

Use the following table to understand the bypass LED on the copper interfaces.

**Table 7-37** 3D7110 and 3D7120 Copper Bypass LED

Status	Description
Off	The interface pair is not in bypass mode or has no power.
Steady green	The interface pair is ready to enter bypass mode.
Steady amber	The interface pair has been placed in bypass mode and is not inspecting traffic.
Blinking amber	The interface pair is in bypass mode; that is, it has failed open.

**Figure 7-12** Eight-Port 1000BASE-SX Fiber Configurable Bypass Interfaces

Use the following table to understand the link and activity LEDs on the fiber interfaces.

**Table 7-38** 3D7110 and 3D7120 Fiber Link/Activity LEDs

Status	Description
Top (activity)	For an inline interface: the light is on when the interface has activity. If dark, there is no activity. For a passive interface: the light is non-functional.
Bottom (link)	For an inline or passive interface: the light is on when the interface has link. If dark, there is no link.

Use the following table to understand the activity and link LEDs on the fiber interfaces.

**Table 7-39** 3D7110 and 3D7120 Fiber Bypass LEDs

Status	Description
Off	The interface pair is not in bypass mode or has no power.
Steady green	The interface pair is ready to enter bypass mode.

**Table 7-39 3D7110 and 3D7120 Fiber Bypass LEDs (continued)**

Status	Description
Steady amber	The interface pair has been placed in bypass mode and is not inspecting traffic.
Blinking amber	The interface pair is in bypass mode; that is, it has failed open.

## 3D7110 and 3D7120 Chassis Rear View

The rear of the chassis contains the management interface, connection ports, grounding studs, and power supplies.

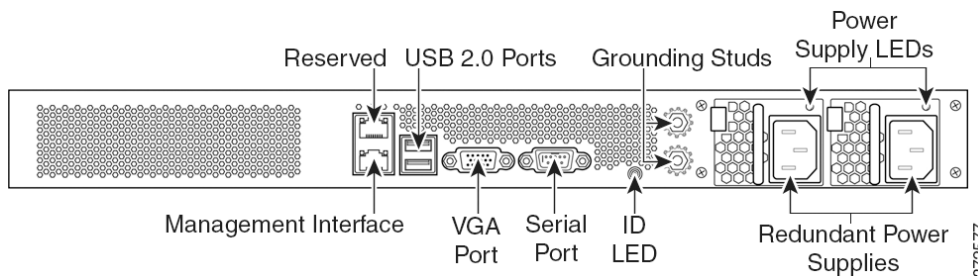
**Figure 7-13 3D7110 and 3D7120 (Chassis: GERY-1U-8-C-AC or GERY-1U-8-FM-AC) Rear View**

The following table describes the features that appear on the rear of the appliance.

**Table 7-40 3D7110 and 3D7120 System Components: Rear View**

Features	Description
VGA port USB port	Allows you to attach a monitor, keyboard, and mouse to the device to establish a direct workstation-to-appliance connection.
10/100/1000 Ethernet management interface	Provides for an out-of-band management network connection. The management interface is used for maintenance and configuration purposes <b>only</b> and is not intended to carry service traffic.
System ID LED	Helps identify a system installed in a high-density rack with other similar systems. The blue light indicates that the ID button is pressed.
Grounding studs	Allows you to connect the appliance to the Common Bonding Network. See the <a href="#">Power Requirements for FirePOWER Devices, page A-1</a> for more information.
Redundant power supplies	Provides power to the device through an AC power source. Looking at the rear of the chassis, power supply #1 is on the left and power supply #2 is on the right.
Power supply LEDs	Indicates the status of the power supply. See <a href="#">Table 7-423D7110 and 3D7120 Power Supply LED, page 7-31</a> .

The 10/100/1000 management interface is located on the rear of the appliance. The following table describes the LEDs associated with the management interface.

**Table 7-41 3D7110 and 3D7120 Management Interface LEDs**

LED	Description
Left (activity)	Indicates activity on the port: <ul style="list-style-type: none"> <li>• A blinking light indicates activity.</li> <li>• No light indicates there is no activity.</li> </ul>
Right (link)	Indicates whether the link is up: <ul style="list-style-type: none"> <li>• A light indicates the link is up.</li> <li>• No light indicates there is no link.</li> </ul>

The power supply modules are located on the rear of the appliance. The following table describes the LED associated with the power supply.

**Table 7-42 3D7110 and 3D7120 Power Supply LED**

LED	Description
Off	The power cord is not plugged in.
Red	No power supplied to this module. or A power supply critical event, such as module failure, a blown fuse, or a fan failure; the power supply shuts down.
Blinking red	A power supply warning event, such as high temperature or a slow fan; the power supply continues to operate.
Blinking green	AC input is present; volts on standby, the power supply is switched off.
Green	The power supply is plugged in and on.

## 3D7110 and 3D7120 Physical and Environmental Parameters

The following table describes the physical attributes and the environmental parameters for the appliance.

**Table 7-43 3D7110 and 3D7120 Physical and Environmental Parameters**

Parameter	Description
Form factor	1U
Dimensions (D x W x H)	21.6 in. x 19.0 in. x 1.73 in. (54.9 cm x 48.3 cm x 4.4 cm)
Weight maximum installed	27.5 lbs (12.5 kg)
Copper 1000BASE-T	Gigabit copper Ethernet bypass-capable interfaces in a paired configuration Cable and distance: Cat5E at 50 m
Fiber 1000BASE-SX	Fiber bypass-capable interfaces with LC connectors Cable and distance: SX is multimode fiber (850 nm) at 550 m (standard)

Table 7-43 3D7110 and 3D7120 Physical and Environmental Parameters (continued)

Parameter	Description
Power supply	450 W dual redundant (1+1) AC power supplies Voltage: 100 VAC to 240 VAC nominal (85 VAC to 264 VAC maximum) Current: 3A maximum for 90 VAC to 132 VAC, per supply 1.5A maximum for 187 VAC to 264 VAC, per supply Frequency range: 47 Hz to 63 Hz
Operating temperature	41°F to 104°F (5°C to 40°C)
Non-operating temperature	-29°F to 158°F (-20°C to 70°C)
Operating humidity	5% to 85% non-condensing
Non-operating humidity	5% to 90%, non-condensing with a maximum wet bulb of 82°F (28°C) at temperatures from 77°F to 95°F (25°C to 35°C)  Store the unit below 95% non-condensing relative humidity. Acclimate below maximum operating humidity at least 48 hours before placing the unit in service.
Altitude	0ft (sea level) to 5905 ft (0 m to 1800 m)
Cooling requirements	900 BTU/hour  You must provide sufficient cooling to maintain the appliance within its required operating temperature range. Failure to do this may cause a malfunction or damage to the appliance.
Acoustic noise	64 dBA at full processor load, normal fan operation Meets GR-63-CORE 4.6 Acoustic Noise
Operating shock	Complies with Bellecore GR-63-CORE standards
Airflow	140 ft <sup>3</sup> (3.9 m <sup>3</sup> ) per minute  Airflow through the appliance enters at the front and exits at the rear with no side ventilation.

## 3D7115, 3D7125, and AMP7150

The 3D7115, 3D7125, and AMP7150 devices, part of the 71xx Family, are delivered with four-port copper interfaces with configurable bypass capability, and eight hot-swappable small form-factor pluggable (SFP) ports without bypass capability. To ensure compatibility, use only Cisco SFP transceivers. See the *Regulatory Compliance and Safety Information for FirePOWER and FireSIGHT Appliances*.



### Note

The FirePOWER AMP7150 has many of the same form factors as the 3D7115 and 3D7125, but has been optimized to take advantage of the FireSIGHT System's network-based advanced malware protection (AMP) capabilities.

See the following sections for more information:

- [3D7115, 3D7125, and AMP7150 Chassis Front View, page 7-33](#)
- [3D7115, 3D7125, and AMP7150 Chassis Rear View, page 7-37](#)
- [3D7115, 3D7125, and AMP7150 Physical and Environmental Parameters, page 7-39](#)



### 3D7115, 3D7125, and AMP7150 Chassis Front View

The front of the chassis contains the LCD panel, USB port, front panel, copper sensing interfaces, and SFP sockets.

**Figure 7-14** 3D7115, 3D7125, and AMP7150 (Chassis: GERY-1U-8-4C8S-AC) Front View

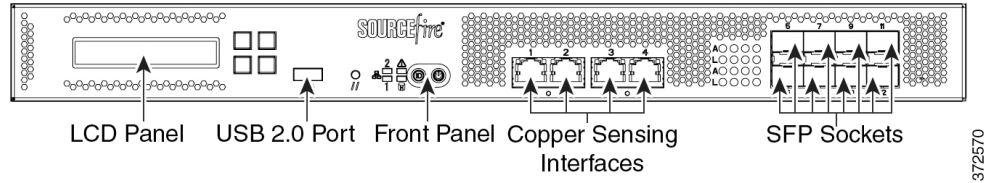

The following table describes the features on the front of the appliance.

**Table 7-44** 3D7115, 3D7125, and AMP7150 System Components: Front View

Feature	Description
LCD panel	Operates in multiple modes to configure the device, display error messages, and view system status. For more information, see <a href="#">Using the LCD Panel on a Series 3 Device, page 6-1</a> .
Front panel USB 2.0 port	Allows you to attach a keyboard to the device.
Front panel	Houses LEDs that display the system’s operating state, as well as various controls, such as the power button. For more information, see <a href="#">Figure 7-153D7115, 3D7125, and AMP7150 Front Panel, page 7-33</a> .
Sensing interfaces	Contain the sensing interfaces that connect to the network. For more information, see <a href="#">3D7115, 3D7125, and AMP7150 Sensing Interfaces, page 7-35</a> .

**Figure 7-15** 3D7115, 3D7125, and AMP7150 Front Panel

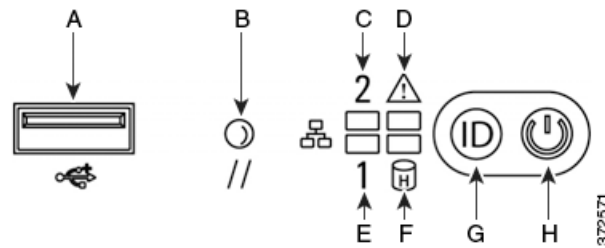

**Table 7-45** 3D7115, 3D7125, and AMP7150 Front Panel Components

A	USB 2.0 connector	E	NIC1 activity LED
B	Reset button	F	Hard drive activity LED
C	NIC2 activity LED	G	ID button
D	System status LED	H	Power button and LED

The front panel of the chassis houses LEDs, which display the system’s operating state. The following table describes the LEDs on the front panel.

**Table 7-46** 3D7115, 3D7125, and AMP7150 Front Panel LEDs

LED	Description
NIC activity (1 and 2)	Indicates whether there is any network activity: <ul style="list-style-type: none"> <li>• A green light indicates there is network activity.</li> <li>• No light indicates there is no network activity.</li> </ul>
System status	Indicates the system status: <ul style="list-style-type: none"> <li>• No light indicates the system is operating normally, or is powered off.</li> <li>• A red light indicates a system error.</li> </ul> See the <a href="#">Table 7-473D7115, 3D7125, and AMP7150 System Status, page 7-35</a> for more information.
Reset button	Allows you to reboot the appliance without disconnecting it from the power supply.
Hard drive activity	Indicates the hard drive status: <ul style="list-style-type: none"> <li>• A blinking green light indicates the fixed disk drive is active.</li> <li>• An amber light indicates a fixed disk drive fault.</li> <li>• If the light is off, there is no drive activity or the system is powered off.</li> </ul>
System ID	Helps identify a system installed in a high-density rack with other similar systems: <ul style="list-style-type: none"> <li>• A blue light indicates the ID button is pressed and a blue light is on at the rear of the appliance.</li> <li>• No light indicates the ID button is not pressed.</li> </ul>
Power button and LED	Indicates whether the appliance has power: <ul style="list-style-type: none"> <li>• A green light indicates that the appliance has power and the system is on.</li> <li>• A blinking green light indicates that the appliance has power and is shut down.</li> <li>• No light indicates the system does not have power.</li> </ul>

The following table describes the conditions under which the system status LEDs might be lit.

**Table 7-47** 3D7115, 3D7125, and AMP7150 System Status

Condition	Description
Critical	Any critical or non-recoverable threshold crossing associated with the following events: <ul style="list-style-type: none"> <li>temperature, voltage, or fan critical threshold crossing</li> <li>power subsystem failure</li> <li>system inability to power up due to incorrectly installed processors or processor incompatibility</li> <li>critical event logging errors, including System Memory Uncorrectable ECC error and fatal/uncorrectable bus errors, such as PCI SERR and PERR</li> </ul>
Non-critical	A non-critical condition is a threshold crossing associated with the following events: <ul style="list-style-type: none"> <li>temperature, voltage, or fan non-critical threshold crossing</li> <li>chassis intrusion</li> <li>Set Fault Indication command from system BIOS; the BIOS may use the command to indicate additional non-critical status such as system memory or CPU configuration changes</li> </ul>
Degraded	Any degraded condition is associated with the following events: <ul style="list-style-type: none"> <li>one or more processors are disabled by Fault Resilient Boot (FRB) or BIOS</li> <li>some system memory disabled or mapped out by BIOS</li> <li>one of the power supplies unplugged or not functional</li> </ul> <p><b>Tip</b> If you observe a degraded condition indication, check your power supply connections first. Power down the device, disconnect both power cords, reconnect the power cords to reseal them, then restart the device.</p> <p><b>Caution</b>  To power down safely, use the procedure in the Managing Devices chapter in the <i>FireSIGHT System User Guide</i>, or the <code>system shutdown</code> command from the CLI.</p>

### 3D7115, 3D7125, and AMP7150 Sensing Interfaces

The 3D7115, 3D7125, and AMP7150 devices are delivered with four-port copper interfaces with configurable bypass capability, and eight hot-swappable small form-factor pluggable (SFP) ports without bypass capability.

**Figure 7-16** Four 1000BASE-T Copper Interfaces

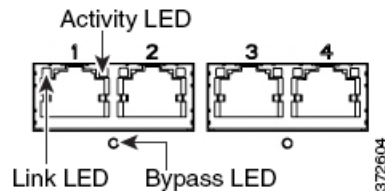

Use the following table to understand the link and activity LEDs on copper interfaces.

**Table 7-48 3D7115, 3D7125, and AMP7150 Copper Link/Activity LEDs**

Status	Description
Both LEDs off	The interface does not have link.
Link amber	The speed of the traffic on the interface is 10Mb or 100Mb.
Link green	The speed of the traffic on the interface is 1Gb.
Activity blinking green	The interface has link and is passing traffic.

Use the following table to understand the bypass LED on copper interfaces.

**Table 7-49 3D7115, 3D7125, and AMP7150 Copper Bypass LED**

Status	Description
Off	The interface pair is not in bypass mode or has no power.
Steady green	The interface pair is ready to enter bypass mode.
Steady amber	The interface pair has been placed in bypass mode and is not inspecting traffic.
Blinking amber	The interface pair is in bypass mode; that is, it has failed open.

**SFP Interfaces**

You can install up to eight hot-swappable Cisco SFP transceivers, available in 1G copper, 1G short range fiber, or 1G long range fiber. SFP transceivers do not have bypass capability and should not be used in intrusion prevention deployments. See [Using SFP Transceivers in 3D71x5 and AMP7150 Devices](#), page B-1 for more information.

**Figure 7-17 Sample SFP Transceivers**

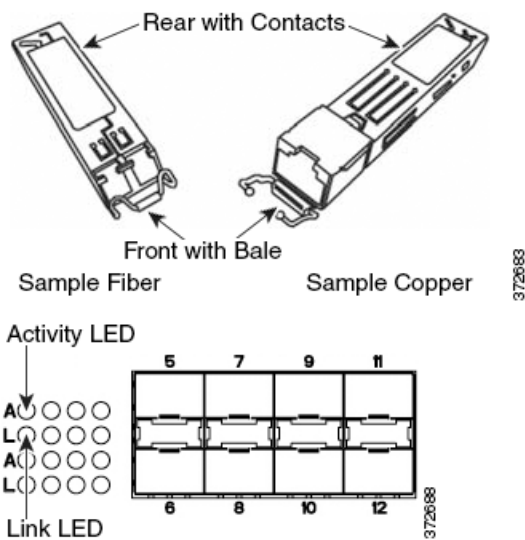

Use the following table to understand the fiber LEDs.

**Table 7-50 3D7115, 3D7125, and AMP7150 SFP Socket Activity/Link LEDs**

Status	Description
Top (activity)	For an inline interface: the light is on when the interface has activity. If dark, there is no activity. For a passive interface: the light is non-functional.
Bottom (link)	For an inline or passive interface: the light is on when the interface has link. If dark, there is no link.

Use the following table to understand the specifications of the SFP optical transceivers.

**Table 7-51 3D7115, 3D7125, and AMP7150 SFP Optical Parameters**

Parameter	1000BASE-SX	1000BASE-LX
Optical connectors	LC duplex	LC duplex
Bit rate	1000Mbps	1000Mbps
Baud rate/encoding/tolerance	1250Mbps 8b/10b encoding	1250Mbps 8b/10b encoding
Optical interface	Multimode	Single mode only
Operating distances	656 ft (200 m) for 62.5 μm/125 μm fiber 1640 ft (500 m) for 50 μm/125 μm fiber	6.2 miles (10 km) for 9 μm/125 μm fiber
Transmitter wavelength	770-860 nm (850 nm typical)	1270-1355 nm (1310 nm typical)
Maximum average launch power	0 dBm	-3 dBm
Minimum average launch power	-9.5 dBm	-11.5 dBm
Maximum average power at receiver	0 dBm	-3 dBm
Receiver sensitivity	-17 dBm	-19 dBm

### 3D7115, 3D7125, and AMP7150 Chassis Rear View

The rear of the chassis contains the management interface, connection ports, grounding studs, and power supplies.

**Figure 7-18 3D7115, 3D7125, and AMP7150 (Chassis: GERY-1U-8-4C8S-AC) Rear View**

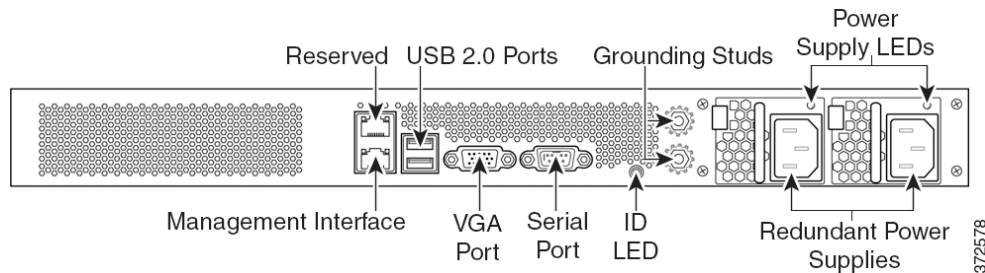

The following table describes the features that appear on the rear of the appliance.

**Table 7-52 3D7115, 3D7125 and AMP7150 System Components: Rear View**

Features	Description
VGA port USB port	Allows you to attach a monitor, keyboard, and mouse to the device to establish a direct workstation-to-appliance connection.
10/100/1000 Ethernet management interface	Provides for an out-of-band management network connection. The management interface is used for maintenance and configuration purposed <b>only</b> and is not intended to carry service traffic.
System ID LED	Helps identify a system installed in a high-density rack with other similar systems. The blue light indicates that the ID button is pressed.
Grounding studs	Allows you to connect the appliance to the Common Bonding Network. See the <a href="#">Power Requirements for FirePOWER Devices, page A-1</a> for more information.
Redundant power supplies	Provides power to the device through an AC power source. Looking at the rear of the chassis, power supply #1 is on the left and power supply #2 is on the right.
Power supply LEDs	Indicates the status of the power supply. See <a href="#">Table 7-54 3D7115, 3D7125, and AMP7150 Power Supply LED, page 7-38</a> .

The 10/100/1000 management interface is located on the rear of the appliance. The following table describes the LEDs associated with the management interface.

**Table 7-53 3D7115, 3D7125, and AMP7150 Management Interface LEDs**

LED	Description
Left (activity)	Indicates activity on the port: <ul style="list-style-type: none"> <li>• A blinking light indicates activity.</li> <li>• No light indicates there is no activity.</li> </ul>
Right (link)	Indicates whether the link is up: <ul style="list-style-type: none"> <li>• A light indicates the link is up.</li> <li>• No light indicates there is no link.</li> </ul>

The power supply modules are located on the rear of the appliance. The following table describes the LED associated with the power supply.

**Table 7-54 3D7115, 3D7125, and AMP7150 Power Supply LED**

LED	Description
Off	The power cord is not plugged in.
Red	No power supplied to this module. or A power supply critical event, such as module failure, a blown fuse, or a fan failure; the power supply shuts down.
Blinking red	A power supply warning event, such as high temperature or a slow fan; the power supply continues to operate.

**Table 7-54 3D7115, 3D7125, and AMP7150 Power Supply LED (continued)**

LED	Description
Blinking green	AC input is present; volts on standby, the power supply is switched off.
Green	The power supply is plugged in and on.

### 3D7115, 3D7125, and AMP7150 Physical and Environmental Parameters

The following table describes the physical attributes and the environmental parameters for the appliance.

**Table 7-55 3D7115, 3D7125, and AMP7150 Physical and Environmental Parameters**

Parameter	Description
Form factor	1U
Dimensions (D x W x H)	21.6 in. x 19.0 in. x 1.73 in. (54.9 cm x 48.3 cm x 4.4 cm)
Weight maximum installed	29.0 lbs (13.2 kg)
Copper 1000BASE-T	Gigabit copper Ethernet bypass-capable interfaces in a paired configuration Cable and distance: Cat5E at 50 m
Copper 1000BASE-T SFP	Gigabit copper Ethernet non-bypass capable interfaces in a paired configuration Cable and distance: Cat5E at 50 m
Fiber 1000BASE-SX SFP	Fiber non-bypass capable interfaces with LC connectors Cable and distance: SX is multimode fiber (850 nm) at 550 m (standard) 656 ft (200 m) for 62.5 μm/125 μm fiber 1640 ft (500 m) for 50 μm/125 μm fiber
Fiber 1000BASE-LX SFP	Fiber non-bypass capable interfaces with LC connectors Cable and distance: LX is single mode fiber (1310 nm) at 10 km for 9 μm/125 μm fiber (standard)
Power supply	450 W dual redundant (1+1) AC power supplies Voltage: 100 VAC to 240 VAC nominal (85 VAC to 264 VAC maximum) Current: 3A maximum for 90 VAC to 132 VAC, per supply 1.5A maximum for 187 VAC to 264 VAC, per supply Frequency range: 47 Hz to 63 Hz
Operating temperature	41°F to 104°F (5°C to 40°C)
Non-operating temperature	-29°F to 158°F (-20°C to 70°C)
Operating humidity	5% to 85% non-condensing
Non-operating humidity	5% to 90%, non-condensing with a maximum wet bulb of 82°F (28°C) at temperatures from 77°F to 95°F (25°C to 35°C)  Store the unit below 95% non-condensing relative humidity. Acclimate below maximum operating humidity at least 48 hours before placing the unit in service.
Altitude	0ft (sea level) to 5905 ft (0 m to 1800 m)
Cooling requirements	900 BTU/hour  You must provide sufficient cooling to maintain the appliance within its required operating temperature range. Failure to do this may cause a malfunction or damage to the appliance.

Table 7-55 3D7115, 3D7125, and AMP7150 Physical and Environmental Parameters (continued)

Parameter	Description
Acoustic noise	64 dBA at full processor load, normal fan operation Meets GR-63-CORE 4.6 Acoustic Noise
Operating shock	Complies with Bellecore GR-63-CORE standards
Airflow	140 ft <sup>3</sup> (3.9 m <sup>3</sup> ) per minute Airflow through the appliance enters at the front and exits at the rear with no side ventilation.

## 8000 Series Devices

The 8000 Series devices use network modules (NetMods) that contain either copper or fiber sensing interfaces. The devices can be shipped fully assembled or you can install the modules. Assemble your device before installing the FireSIGHT System. See the assembly instructions shipped with your modules.

Some 8000 Series devices can be stacked to increase the capability of the system. For each stacking kit, you replace a NetMod with a stacking module and cable the devices together using the 8000 Series stacking cable. See [Using Devices in a Stacked Configuration, page 4-17](#) for more information.

The 8000 Series device can be delivered on a variety of chassis:

- 3D8120, 3D8130, 3D8140, and AMP8150, also known as the 81xx Family, is a 1U chassis and can contain up to three modules. For the 3D8140 only, you can add a stacking kit for a total 2U configuration.



**Note** The FirePOWER AMP8150 has many of the same form factors as the 3D8130, but has been optimized to take advantage of FireSIGHT System's network-based advanced malware protection (AMP) capabilities.

- 3D8250, part of the 82xx Family, is a 2U chassis and can contain up to seven modules. You can add up to three stacking kits for a total 8U configuration.
- 3D8260, part of the 82xx Family, is a 4U configuration with two 2U chassis. The primary chassis contains one stacking module and up to six sensing modules. The secondary chassis contains one stacking module. You can add up to two stacking kits for a total 8U configuration.
- 3D8270, part of the 82xx Family, is a 6U configuration with three 2U chassis. The primary chassis contains two stacking modules and up to five sensing modules. Each secondary chassis contains one stacking module. You can add one stacking kit for a total 8U configuration.
- 3D8290, part of the 82xx Family, is an 8U configuration with four 2U chassis. The primary chassis contains three stacking modules and up to four sensing modules. Each secondary chassis contains one stacking module. This model is fully configured and does not accept a stacking kit.
- 3D8350, part of the 83xx Family, is a 2U chassis and can contain up to seven modules. You can add up to three stacking kits for a total 8U configuration.
- 3D8360, part of the 83xx Family, is a 4U configuration with two 2U chassis. The primary chassis contains one stacking module and up to six sensing modules. The secondary chassis contains one stacking module. You can add up to two stacking kits for a total 8U configuration.



- 3D8370, part of the 83xx Family, is a 6U configuration with three 2U chassis. The primary chassis contains two stacking modules and up to five sensing modules. Each secondary chassis contains one stacking module. You can add one stacking kit for a total 8U configuration.
- 3D8390, part of the 83xx Family, is an 8U configuration with four 2U chassis. The primary chassis contains three stacking modules and up to four sensing modules. Each secondary chassis contains one stacking module. This model is fully configured and does not accept a stacking kit.

See the following sections for more information:

- 8000 Series Chassis Front View, page 7-41
- 8000 Series Chassis Rear View, page 7-44
- 8000 Series Physical and Environmental Parameters, page 7-47
- 8000 Series Modules, page 7-50

## 8000 Series Chassis Front View

The 8000 Series chassis can be in the 81xx Family, the 82xx Family, or the 83xx Family. See the *Regulatory Compliance and Safety Information for FirePOWER and FireSIGHT Appliances* document for safety considerations for 81xx Family, 82xx Family, and 83xx Family appliances.

### 81xx Family Chassis Front View

The front view of the chassis contains the LCD panel, front panel, and three module slots.

**Figure 7-19** 81xx Family (Chassis: CHAS-1U-AC/DC) Front View

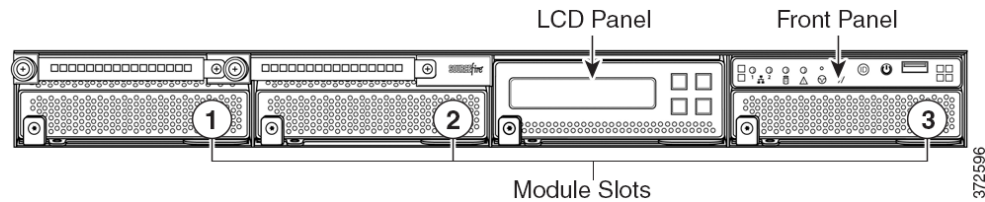

### 82xx Family and 83xx Family Chassis Front View

The front view of the chassis contains the LCD panel, front panel, and seven module slots.

**Figure 7-20** 82xx Family (Chassis: CHAS-2U-AC/DC) and 83xx Family (PG35-2U-AC/DC) Front View

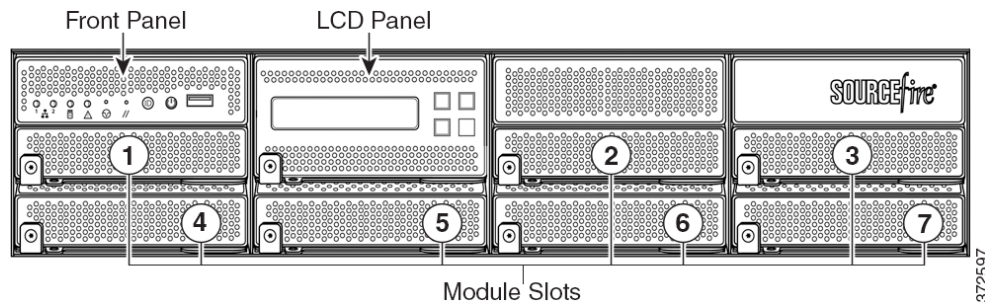

The following table describes the features on the front of the appliance.

**Table 7-56 8000 Series System Components: Front View**

Feature	Description
Module slots	Contain the modules. For information on available modules, see <a href="#">8000 Series Modules, page 7-50</a> .
LCD panel	Operates in multiple modes to configure the device, display error messages, and view system status. For more information, see <a href="#">Using the LCD Panel on a Series 3 Device, page 6-1</a> .
Front panel controls	Houses LEDs that display the system's operating state, as well as various controls, such as the power button. For more information, see <a href="#">Figure 7-2282xx Family and 83xx Family Front Panel, page 7-42</a> .
Front panel USB port	The USB 2.0 port allows you to attach a keyboard to the device.

See the following sections for more information:

- [8000 Series Front Panel, page 7-42](#)
- [8000 Series Chassis Rear View, page 7-44](#)

## 8000 Series Front Panel

The front panel for the 81xx Family, 82xx Family, and 83xx Family contain the same components.

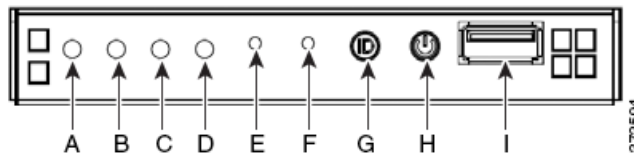
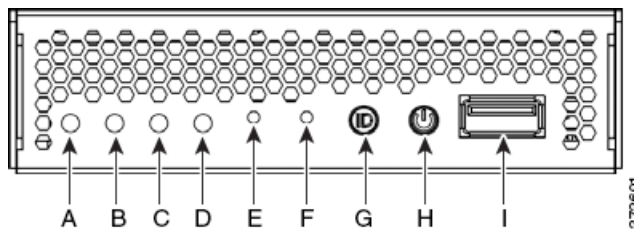
**Figure 7-21 81xx Family Front Panel****Figure 7-22 82xx Family and 83xx Family Front Panel****Table 7-57 8000 Series Front Panel Components**

A	NIC activity LED	F	Reset button
B	Reserved	G	ID button
C	Hard drive activity LED	H	Power button and LED
D	System status LED	I	USB 2.0 connector
E	Non-maskable interrupt button		

The front panel of the chassis houses LEDs, which display the system's operating state. The following table describes the LEDs on the front panel

**Table 7-58**      **8000 Series Front Panel LEDs**

LED	Description
NIC activity	Indicates whether there is any network activity: <ul style="list-style-type: none"> <li>• Green indicates there is network activity.</li> <li>• If the light is off, there is no network activity.</li> </ul>
Hard drive activity	Indicates the hard drive status: <ul style="list-style-type: none"> <li>• Blinking green indicates the fixed disk drive is active.</li> <li>• Amber indicates a fixed disk drive fault.</li> <li>• If the light is off, there is no drive activity or the system is powered off.</li> </ul>
System status	Indicates the system status: <ul style="list-style-type: none"> <li>• Green indicates the system is operating normally.</li> <li>• Blinking green indicates the system is operating in a degraded condition.</li> <li>• Blinking amber indicates the system is in a non-critical condition.</li> <li>• Amber indicates the system is in a critical or non-recoverable condition, or the system is starting up.</li> <li>• If the light is off, the system is starting up or off.</li> </ul> <p><b>Note</b> The amber status light takes precedence over the green status light. When the amber light is on or blinking, the green light is off.</p> <p>See <a href="#">Table 7-59 on page 7-44</a> for more information.</p>
System ID	Helps identify a system installed in a high-density rack with other similar systems: <ul style="list-style-type: none"> <li>• A blue light indicates the ID button is pressed and a blue light is on at the rear of the appliance.</li> <li>• No light indicates the ID button is not pressed.</li> </ul>
Power button and LED	Indicates whether the system has power: <ul style="list-style-type: none"> <li>• Green indicates that the system has power.</li> <li>• If the light is off, the system does not have power.</li> </ul>

The following table describes the conditions under which the system status LEDs might be lit.

Table 7-59 8000 Series System Status

Condition	Description
Critical	<p>Any critical or non-recoverable threshold crossing associated with the following events:</p> <ul style="list-style-type: none"> <li>• temperature, voltage, or fan critical threshold crossing</li> <li>• power subsystem failure</li> <li>• system inability to power up due to incorrectly installed processors or processor incompatibility</li> <li>• critical event logging errors, including System Memory Uncorrectable ECC error and fatal/uncorrectable bus errors, such as PCI SERR and PERR</li> </ul>
Non-critical	<p>A non-critical condition is a threshold crossing associated with the following events:</p> <ul style="list-style-type: none"> <li>• temperature, voltage, or fan non-critical threshold crossing</li> <li>• chassis intrusion</li> <li>• Set Fault Indication command from system BIOS; the BIOS may use the command to indicate additional, non-critical status such as system memory or CPU configuration changes</li> </ul>
Degraded	<p>A degraded condition is associated with the following events:</p> <ul style="list-style-type: none"> <li>• one or more processors are disabled by Fault Resilient Boot (FRB) or BIOS</li> <li>• some system memory disabled or mapped out by BIOS</li> <li>• one of the power supplies unplugged or not functional</li> </ul> <p><b>Tip</b> If you observe a degraded condition indication, check your power supply connections first. Power down the device, disconnect both power cords, reconnect the power cords to reseat them, and then restart the device.</p> <p> <b>Caution</b> To power down safely, use the procedure in the Managing Devices chapter in the <i>FireSIGHT System User Guide</i>, or the <code>system shutdown</code> command from the CLI.</p>

## 8000 Series Chassis Rear View

The 8000 Series chassis can be in the 81xx Family, 82xx Family, or 83xx Family.

### 81xx Family Chassis Rear View

The rear view of the chassis contains connection ports, the management interface, and the power supplies.

**Figure 7-23 81xx Family (Chassis: CHAS-1U-AC/DC) Rear View**

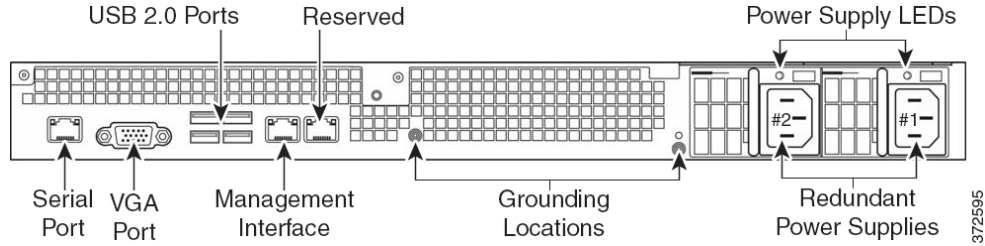

372595

### 82xx Family Chassis Rear View

The rear view of the chassis contains power supplies, connection ports, and the management interface.

**Figure 7-24 82xx Family (Chassis: CHAS-2U-AC/DC) Rear View**

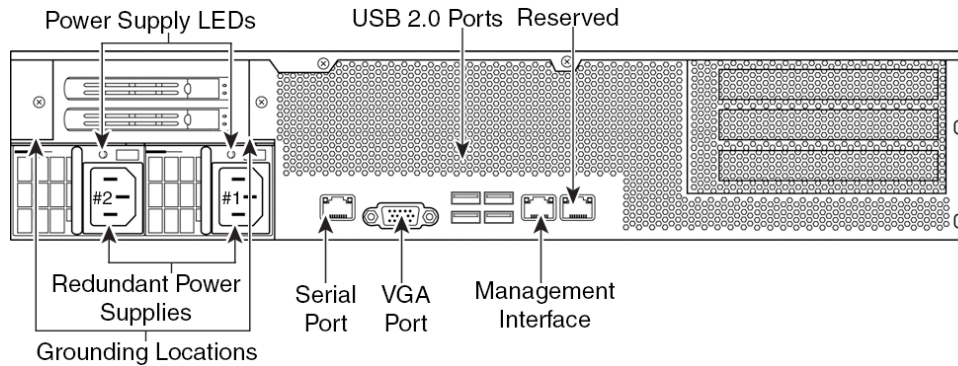

372600

### 83xx Family Chassis Rear View

The rear view of the chassis contains power supplies, connection ports, and the management interface.

**Figure 7-25 83xx Family (Chassis: PG35-2U-AC/DC) Rear View**

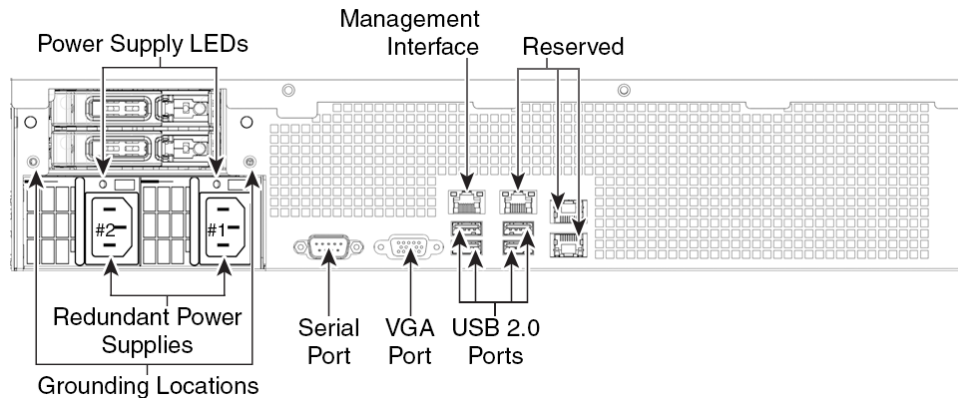

372602

The following table describes the features that appear on the rear of the appliance.

**Table 7-60 8000 Series System Components: Rear View**

Feature	Description
VGA port USB 2.0 ports	Allows you to attach a monitor, keyboard, and mouse to the device, as an alternative to using the serial port, to establish a direct workstation-to-appliance connection.
RJ45 serial port (81xx Family and 82xx Family)	Allows you to establish a direct workstation-to-appliance connection (using an RJ45 to DB-9 adapter) for direct access to all of the management services on the device. The RJ45 serial port is used for maintenance and configuration purposes <b>only</b> and is not intended to carry service traffic.
RS232 serial port (83xx Family)	Allows you to establish a direct workstation-to-appliance connection for direct access to all of the management services on the device. The RJ232 serial port is used for maintenance and configuration purposes <b>only</b> and is not intended to carry service traffic.
10/100/1000 Ethernet management interface	Provides for an out-of-band management network connection. The management interface is used for maintenance and configuration purposes <b>only</b> and is not intended to carry service traffic.
Redundant power supplies	Provides power to the device through an AC power source. Looking at the rear of the chassis, power supply #1 is on the right and power supply #2 is on the left.
Grounding locations	Allows you to connect the appliance to the Common Bonding Network. See the <a href="#">Power Requirements for FirePOWER Devices, page A-1</a> for more information.

The 10/100/1000 management interface is located on the rear of the appliance. The following table describes the LEDs associated with the management interface.

**Table 7-61 8000 Series Management Interface LEDs**

LED	Description
Left (activity)	Indicates activity on the port: <ul style="list-style-type: none"> <li>• A blinking light indicates activity.</li> <li>• No light indicates there is no activity.</li> </ul>
Right (link)	Indicates whether the link is up: <ul style="list-style-type: none"> <li>• A light indicates the link is up.</li> <li>• No light indicates there is no link.</li> </ul>

The power supply modules are located on the rear of the appliance. The following table describes the LEDs associated with the management interface.

**Table 7-62 8000 Series Power Supply LEDs**

LED	Description
Off	The power supply is not plugged in.
Amber	No power supplied to this module. or A power supply critical event such as module failure, a blown fuse, or a fan failure; the power supply shuts down.
Blinking amber	A power supply warning event, such as high temperature or a slow fan; the power supply continues to operate.
Blinking green	AC input is present; volts on standby, the power supply is switched off.
Green	The power supply is plugged in and on.

## 8000 Series Physical and Environmental Parameters

The following table describes the physical attributes and environmental parameters for 81xx Family devices.

**Table 7-63 81xx Family Physical and Environmental Parameters**

Parameter	Description
Form factor	1U
Dimensions (D x W x H)	28.7 in. x 17.2 in. x 1.73 in. (72.8 cm x 43.3 cm x 4.4 cm)
Weight maximum installed	43.5 lbs (19.8 kg)
Copper 1000BASE-T configurable bypass NetMod	Quad-port Gigabit copper Ethernet configurable bypass interfaces in a paired configuration Cable and distance: Cat5E at 50 m
Fiber 10GBASE configurable bypass MMSR or SMLR NetMod	Dual-port fiber configurable bypass interfaces with LC connectors Cable and distance: LR is single-mode at 5000 m (available) SR is multimode fiber (850 nm) at 550 m (standard)
Fiber 1000BASE-SX configurable bypass NetMod	Quad-port fiber configurable bypass interfaces 1000BASE-SX with LC connectors Cable and distance: SX is multimode fiber (850 nm) at 550 m (standard)
Copper 1000BASE-T non-bypass NetMod	Quad-port Gigabit copper Ethernet non-bypass interfaces in a paired configuration Cable and distance: Cat5E at 50 m
Fiber 10GBASE non-bypass MMSR or SMLR NetMod	Quad-port fiber non-bypass interfaces with LC connectors Cable and distance: LR is single-mode at 5000 m (available) SR is multimode fiber (850 nm) at 550 m (standard)
Fiber 1000BASE-SX non-bypass NetMod	Quad-port fiber non-bypass interfaces 1000BASE-SX with LC connectors Cable and distance: SX is multimode fiber (850 nm) at 550 m (standard)

**Table 7-63** 81xx Family Physical and Environmental Parameters (continued)

Parameter	Description
Power supply	Dual 650 W redundant power supplies designed for AC or DC. AC Voltage: 100 VAC to 240 VAC nominal (85 VAC to 264 VAC maximum) AC Current: 5.2A maximum over the full range, per supply 2.6A maximum for 187 VAC to 264 VAC, per supply AC Frequency range: 47 Hz to 63 Hz DC Voltage: -48 VDC nominal referenced to RTN -40 VDC to -72 VDC maximum DC Current: 11A maximum, per supply
Operating temperature	50°F to 95°F (10°C to 35°C)
Non-operating temperature	-29°F to 158°F (-20°C to 70°C)
Operating humidity	5% to 85% non-condensing
Non-operating humidity	5% to 90%, non-condensing with a maximum wet bulb of 82°F (28°C) at temperatures from 77°F to 95°F (25°C to 35°C)
Altitude	0ft (sea level) to 6000 ft (0 to 1800 m)
Cooling requirements	1725 BTU/hour You must provide sufficient cooling to maintain the appliance within its required operating temperature range. Failure to do this may cause a malfunction or damage to the appliance.
Acoustic noise	Max normal operating noise is 87.6 dB LWAd (high temperature). Typical normal operating noise is 80 dB LWAd.
Operating shock	No errors with half a sine wave shock of 2G (with 11 ms duration)
Airflow	160 ft <sup>3</sup> (4.5 m <sup>3</sup> ) per minute Restriction of the airflow such as blocking the front or back or enclosing the unit in a cabinet without sufficient clearance may cause the unit to overheat, even if the ambient temperature is in the operating range. Airflow through the appliance enters at the front and exits at the rear. The minimum recommended clearance in the front and back is 7.9 in. (20 cm). This minimum can only be used if you can ensure a supply of low temperature air at the front of the appliance.

The following table describes the physical attributes and environmental parameters for 82xx Family and the 83xx Family devices.

**Table 7-64** 82xx Family and 83xx Family Physical and Environmental Parameters

Parameter	Description
Form factor	2U
Dimensions (D x W x H)	29.0 in. x 17.2 in. x 3.48 in. (73.5 cm x 43.3 cm x 88.2 cm)
Weight maximum installed	82xx Family: 58 lbs (25.3 kg) 83xx Family: 67 lbs (30.5 kg)
Copper 1000BASE-T configurable bypass NetMod	Quad-port Gigabit copper Ethernet configurable bypass interfaces in a paired configuration Cable and distance: Cat5E at 50 m



Table 7-64 82xx Family and 83xx Family Physical and Environmental Parameters (continued)

Parameter	Description
Fiber 10GBASE MMSR or SMLR configurable bypass NetMod	Dual-port fiber configurable bypass interfaces with LC connectors Cable and distance: LR is single-mode at 5000 m (available) SR is multimode fiber (850 nm) at 550 m (standard)
Fiber 1000BASE-SX configurable bypass NetMod	Quad-port fiber configurable bypass interfaces 1000BASE-SX with LC connectors Cable and distance: SX is multimode fiber (850 nm) at 550 m (standard)
Fiber 40GBASE-SR4 configurable bypass NetMod	Dual-port fiber configurable bypass interfaces with OTP/MTP connectors Cable and distance: OM3: 100 m at 850 nm Multimode OM4: 150 m at 850 nm Multimode
Copper 1000BASE-T non-bypass NetMod	Quad-port Gigabit copper Ethernet non-bypass interfaces in a paired configuration Cable and distance: Cat5E at 50 m
Fiber 10GBASE non-bypass MMSR or SMLR NetMod	Quad-port fiber non-bypass interfaces with LC connectors Cable and distance: LR is single-mode at 5000 m (available) SR is multimode fiber (850 nm) at 550 m (standard)
Fiber 1000BASE-SX non-bypass NetMod	Quad-port fiber non-bypass interfaces 1000BASE-SX with LC connectors Cable and distance: SX is multimode fiber (850 nm) at 550 m (standard)
Power supply	82xx Family:  Dual 750 W redundant power supplies designed for AC or DC. AC Voltage: 100 VAC to 240 VAC nominal (85 VAC to 264 VAC maximum)  AC Current: 8A maximum over the full range, per supply 4A maximum for 187 VAC to 264 VAC, per supply  AC Frequency range: 47 Hz to 63 Hz DC Voltage: -48 VDC nominal referenced to RTN -40 VDC to -72 VDC maximum  DC Current: 18A maximum, per supply
	83xx Family:  Dual 1000 W redundant power supplies designed for AC or DC. AC Voltage: 100 VAC to 240 VAC nominal (85 VAC to 264 VAC maximum)  AC Current: 11A maximum over the full range, per supply 5.5A maximum for 187 VAC to 264 VAC, per supply  AC Frequency range: 47 Hz to 63 Hz DC Voltage: -48 VDC nominal referenced to RTN -40 VDC to -72 VDC maximum  DC Current: 25A maximum, per supply

Table 7-64 82xx Family and 83xx Family Physical and Environmental Parameters (continued)

Parameter	Description
Operating temperature	82xx Family: 50°F to 95°F (10°C to 35°C)
	83xx Family: 41°F to 104°F (5°C to 40°C)
Non-operating temperature	-29°F to 158°F (-20°C to 70°C)
Operating humidity	5% to 85% non-condensing
Non-operating humidity	5% to 90%, non-condensing with a maximum wet bulb of 82°F (28°C) at temperatures from 77°F to 95°F (25°C to 35°C)
Altitude	0 ft (sea level) to 6000 ft (0 to 1800 m)
Cooling requirements	up to 2900 BTU/hour You must provide sufficient cooling to maintain the appliance within its required operating temperature range. Failure to do this may cause a malfunction or damage to the appliance.
Acoustic noise	Max normal operating noise is 81.6 dB LWAd (high temperature). Typical normal operating noise is 81.4 dB LWAd.
Operating shock	No errors with half a sine wave shock of 2G (with 11 ms duration)
Airflow	Front to back, 210 ft <sup>3</sup> (6 m <sup>3</sup> ) per minute Restriction of the airflow such as blocking the front or back or enclosing the unit in a cabinet without sufficient clearance may cause the unit to overheat, even if the ambient temperature is in the operating range. Airflow through the appliance enters at the front and exits at the rear. The minimum recommended clearance in the front and back is 7.9 in. (20cm). This minimum can only be used if you can ensure a supply of low temperature air at the front of the appliance.

## 8000 Series Modules

The sensing interfaces for the 8000 Series appliances can be delivered with copper or fiber interfaces.



### Caution

Modules are **not** hot-swappable. See [Inserting and Removing 8000 Series Modules, page C-1](#) for more information.

The following modules contain configurable bypass sensing interfaces:

- a quad-port 1000BASE-T copper interface with configurable bypass capability. See [Quad-Port 1000BASE-T Copper Configurable Bypass NetMod, page 7-51](#).
- a quad-port 1000BASE-SX fiber interface with configurable bypass capability. See [Quad-Port 1000BASE-SX Fiber Configurable Bypass NetMod, page 7-52](#) for more information.
- a dual-port 10GBASE (MMSR or SMLR) fiber interface with configurable bypass capability. See [Dual-Port 10GBASE \(MMSR or SMLR\) Fiber Configurable Bypass NetMod, page 7-53](#) for more information.
- a dual-port 40GBASE-SR4 fiber interface with configurable bypass capability (2U devices only). See [Dual-Port 40GBASE-SR4 Fiber Configurable Bypass NetMod, page 7-54](#) for more information.

The following modules contain non-bypass sensing interfaces:

- a quad-port 1000BASE-T copper interface without bypass capability. See [Quad-Port 1000BASE-T Copper Non-Bypass NetMod](#), page 7-56 for more information.
- a quad-port 1000BASE-SX fiber interface without bypass capability. See [Quad-Port 1000BASE-SX Fiber Non-Bypass NetMod](#), page 7-56 for more information.
- a quad-port 10GBASE (MMSR or SMLR) fiber interface without bypass capability. See [Quad-Port 10GBASE \(MMSR or SMLR\) Fiber Non-Bypass NetMod](#), page 7-57 for more information.

In addition, you can use a stacking module to connect two 3D8140, up to four 3D8250, or up to four 3D8350 devices to combine their processing power and increase throughput. See [Stacking Module](#), page 7-59 for more information.

## Quad-Port 1000BASE-T Copper Configurable Bypass NetMod

The quad-port 1000BASE-T copper configurable bypass NetMod contains four copper ports and link, activity, and bypass LEDs.

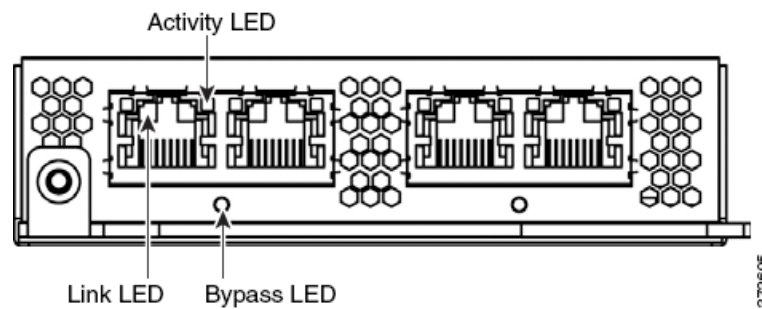

Use the following table to understand the link and activity LEDs on copper interfaces.

**Table 7-65** Copper Link/Activity LEDs

Status	Description
Both LEDs off	The interface does not have link and is not in bypass mode.
Link amber	The speed of the traffic on the interface is 10Mb or 100Mb.
Link green	The speed of the traffic on the interface is 1Gb.
Activity blinking green	The interface has link and is passing traffic.

Use the following table to understand the bypass LEDs on copper interfaces.

**Table 7-66** Copper Bypass LEDs

Status	Description
Off	The interface does not have link and is not in bypass mode.
Steady green	The interface has link and is passing traffic.
Steady amber	The interface has been intentionally brought down.
Blinking amber	The interface is in bypass mode; that is, it has failed open.

## Quad-Port 1000BASE-SX Fiber Configurable Bypass NetMod

The quad-port 1000BASE-SX fiber configurable bypass NetMod contains four fiber ports and link, activity, and bypass LEDs.

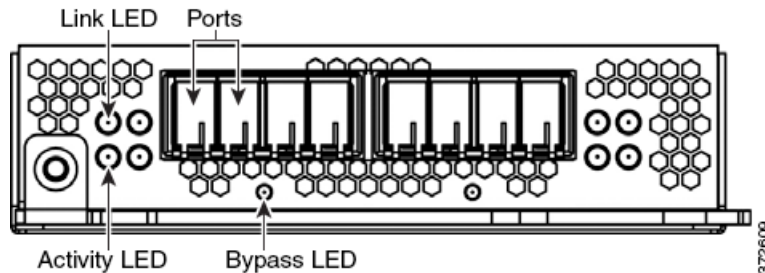

Use the following table to understand link and activity LEDs of the fiber interfaces.

**Table 7-67** Fiber Link/Activity LEDs

Status	Description
Top	For an inline or passive interface: <ul style="list-style-type: none"> <li>A blinking light indicates the interface has activity.</li> <li>No light indicates there is no activity.</li> </ul>
Bottom	For an inline interface: <ul style="list-style-type: none"> <li>A light indicates the interface has activity.</li> <li>No light indicates there is no activity.</li> </ul> For a passive interface, the light is always on.

Use the following table to understand bypass LEDs on the fiber interfaces.

**Table 7-68** Fiber Bypass LEDs

Status	Description
Off	The interface does not have link and is not in bypass mode.
Steady green	The interface has link and is passing traffic.
Steady amber	The interface has been intentionally brought down.
Blinking amber	The interface is in bypass mode; that is, it has failed open.

Use the following table to understand the optical specifications of the fiber interfaces.

**Table 7-69** 1000BASE-SX NetMod Optical Parameters

Parameter	1000BASE-SX
Optical connectors	LC duplex
Bit rate	1000Mbps
Baud rate/encoding/tolerance	1250Mbps 8b/10b encoding

**Table 7-69 1000BASE-SX NetMod Optical Parameters (continued)**

Parameter	1000BASE-SX
Optical interface	Multimode
Operating distances	656 ft (200 m) for 62.5 $\mu\text{m}$ /125 $\mu\text{m}$ fiber 1640 ft (500 m) for 50 $\mu\text{m}$ /125 $\mu\text{m}$ fiber
Transmitter wavelength	770-860 nm (850 nm typical)
Maximum average launch power	0 dBm
Minimum average launch power	-9.5 dBm
Maximum average power at receiver	0 dBm
Receiver sensitivity	-17 dBm

## Dual-Port 10GBASE (MMSR or SMLR) Fiber Configurable Bypass NetMod

The dual-port 10GBASE (MMSR or SMLR) fiber configurable bypass NetMod contains two fiber ports and link, activity, and bypass LEDs.

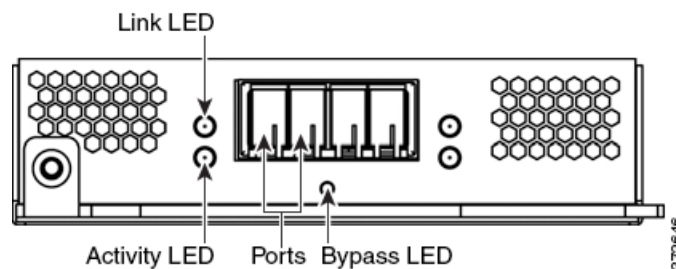

Use the following table to understand link and activity LEDs of the fiber interfaces.

**Table 7-70 Fiber Link/Activity LEDs**

Status	Description
Top	For an inline or passive interface: <ul style="list-style-type: none"> <li>A blinking light indicates the interface has activity.</li> <li>No light indicates there is no activity.</li> </ul>
Bottom	For an inline interface: <ul style="list-style-type: none"> <li>A light indicates the interface has activity.</li> <li>No light indicates there is no activity.</li> </ul> For a passive interface, the light is always on.

Use the following tables to understand the bypass LEDs on the fiber interfaces.

**Table 7-71 Fiber Bypass LEDs**

Status	Description
Off	The interface does not have link and is not in bypass mode.
Steady green	The interface has link and is passing traffic.

**Table 7-71** *Fiber Bypass LEDs (continued)*

Status	Description
Steady amber	The interface has been intentionally brought down.
Blinking amber	The interface is in bypass mode; that is, it has failed open.

Use the following table to understand the optical parameters of the fiber interfaces.

**Table 7-72** *10GBASE MMSR and SMLR NetMod Optical Parameters*

Parameter	10GBASE MMSR	10GBASE SMLR
Optical connectors	LC duplex	LC duplex
Bit rate	10.000Gbps	10.000Gbps
Baud rate/encoding/tolerance	10.3125Gbps 64/66b encoding +/- 100 ppm	10.3125Gbps 64/166b encoding +/- 100 ppm
Optical interface	Multimode	Single mode only
Operating distance	840-860 nm (850 nm typical)  85 ft (26 m) to 108 ft (33 m) for 62.5 $\mu\text{m}$ /125 $\mu\text{m}$ fiber (modal BW 160 to 200 respectively)  216 ft (66 m) to 269 ft (82 m) for 50 $\mu\text{m}$ /125 $\mu\text{m}$ fiber (modal BW 400 to 500 respectively)  Distances to 980 ft (300 m) are available with higher quality (OM3) fiber.  Minimum distances (all): 6ft (2 m)	1270-1355 nm (1310 nm typical)  6 ft to 6.2 miles (2 m to 10 km) for 9 $\mu\text{m}$ /125 $\mu\text{m}$ fiber
Transmitter wavelength	840-860 nm (850 nm typical)	1270-1355 nm (1310 nm typical)
Maximum average launch power	-1 dBm	-0.5 dBm
Minimum average launch power	-7.3 dBm	-8.2 dBm
Maximum average power at receiver	-1 dBm	-0.5 dBm
Receiver sensitivity	-9.9 dBm	-14.4 dBm

## Dual-Port 40GBASE-SR4 Fiber Configurable Bypass NetMod

The dual-port 40GBASE-SR4 fiber configurable bypass NetMod contains two fiber ports and link, activity, and bypass LEDs.

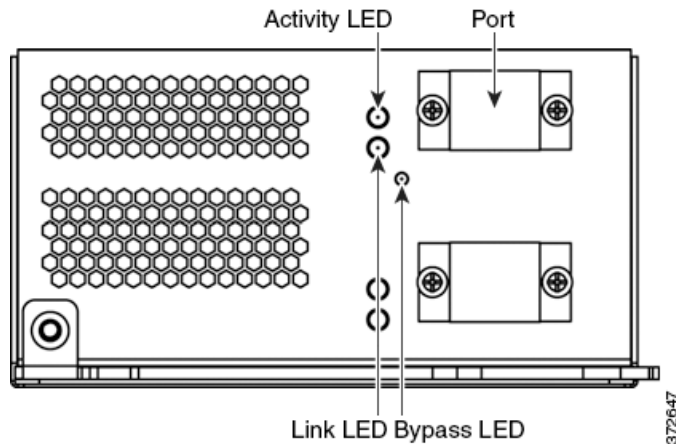

You can use the 40G NetMod only in the 3D8270, 3D8290, 3D8360, 3D8370 and 3D8390; or in a 40G-capable 3D8250, 3D8260 and 3D8350. If you attempt to create a 40G interface on a device that is not 40G-capable, the 40G interface screen on its managing Defense Center web interface displays red. A 40G-capable 3D8250 displays “3D 8250-40G” on the LCD Panel and a 40G-capable 3D8350 displays “3D 8350-40G” on the LCD Panel. See [8000 Series Modules, page 4-12](#) for placement information.

Use the following table to understand link and activity LEDs of the fiber interfaces.

**Table 7-73 Fiber Link/Activity LEDs**

Status	Description
Top (activity)	The light flashes when the interface has activity. If dark, there is no activity.
Bottom (link)	The light is on when the interface has link. If dark, there is no link.

Use the following table to understand bypass LED of the fiber interfaces.

**Table 7-74 Fiber Bypass LED**

Status	Description
Off	The interface pair does not have link and is not in bypass mode, or has no power.
Steady green	The interface pair has link and is passing traffic.
Steady amber	The interface has been intentionally brought down.
Blinking amber	The interface is in bypass mode; that is, it has failed open.

Use the following table to understand optical parameters of the fiber interfaces.

**Table 7-75 40GBASE-SR4 NetMod Optical Parameters**

Parameter	40GBASE-SR4
Optical connectors	OTP/MTP single row twelve fiber positions. Only the outer eight fibers are used.
Bit rate	40.000Gbps

**Table 7-75 40GBASE-SR4 NetMod Optical Parameters (continued)**

Parameter	40GBASE-SR4
Baud rate/encoding/tolerance	10.3125Gbps 64/66b encoding +/- 100 ppm
Optical interface	Multimode
Operating distances	320 ft (100 m) for 50 $\mu$ m/125 $\mu$ m fiber (OM3)  Minimum distance: 2 ft (0.5 m)  40G optics are carried on eight fiber cables utilizing MPO connectors.
Transmitter wavelength	840-860 nm (850 nm typical)
Maximum average launch power	2.4 dBm
Minimum average launch power	-7.8 dBm
Maximum average power at receiver	2.4 dBm
Receiver sensitivity	-9.5 dBm

## Quad-Port 1000BASE-T Copper Non-Bypass NetMod

The quad-port 1000BASE-T copper non-bypass NetMod contains four copper ports, and link and activity LEDs.

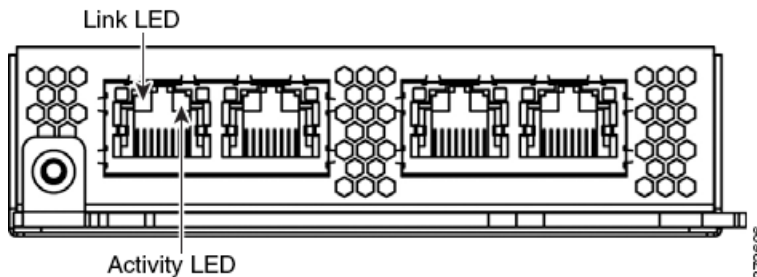

Use the following table to understand copper LEDs.

**Table 7-76 Non-Bypass Copper Link/Activity LEDs**

Status	Description
Both LEDs Off	The interface does not have link.
Link Amber	The speed of the traffic on the interface is 10Mb or 100Mb.
Link Green	The speed of the traffic on the interface is 1Gb.
Activity Blinking Green	The interface has link and is passing traffic.

## Quad-Port 1000BASE-SX Fiber Non-Bypass NetMod

The quad-port 1000BASE-SX fiber non-bypass NetMod contains four fiber ports, and link and activity LEDs.



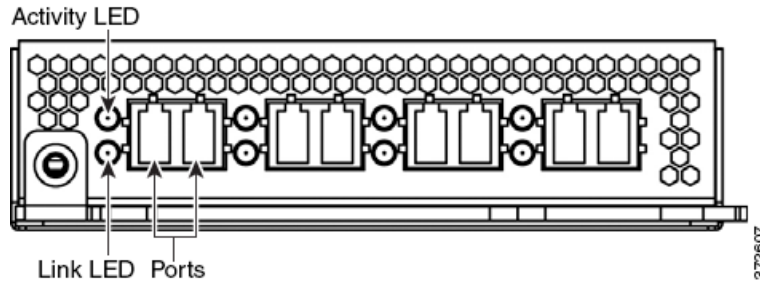

Use the following table to understand the link and activity LEDs on the fiber interfaces.

**Table 7-77 Non-Bypass Fiber Link/Activity LEDs**

Status	Description
Top (Activity)	For an inline or passive interface: the light flashes when the interface has activity. If dark, there is no activity.
Bottom (Link)	For an inline interface: the light is on when the interface has link. If dark, there is no link. For a passive interface: the light is always on.

Use the following table to understand the optical parameters of the fiber interfaces.

**Table 7-78 1000BASE-SX NetMod Optical Parameters**

Parameter	1000BASE-SX
Optical connectors	LC duplex
Bit rate	1000Mbps
Baud rate/encoding/tolerance	1250Mbps 8b/10b encoding
Optical interface	Multimode
Operating distances	656 ft (200 m) for 62.5 μm/125 μm fiber 1640 ft (500 m) for 50 μm/125 μm fiber
Transmitter wavelength	770-860 nm (850 nm typical)
Maximum average launch power	0 dBm
Minimum average launch power	-9.5 dBm
Maximum average power at receiver	0 dBm
Receiver sensitivity	-17 dBm

### Quad-Port 10GBASE (MMSR or SMLR) Fiber Non-Bypass NetMod

The quad-port 10GBASE (MMSR or SMLR) fiber non-bypass NetMod contains four fiber ports, and link and activity LEDs.

**Caution**

The quad-port 10GBASE non-bypass NetMod contains non-removable SFPs. Any attempt to remove the SFP may damage the module.

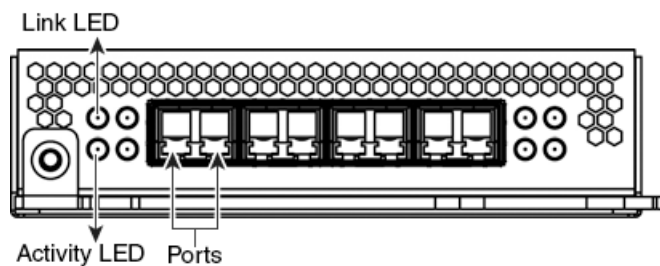

Use the following table to understand the link and activity LEDs on fiber interfaces.

**Table 7-79 Fiber Link/Activity LEDs**

Status	Description
Top	For an inline or passive interface: the light flashes when the interface has activity. If dark, there is no activity.
Bottom	For an inline interface: the light is on when the interface has link. If dark, there is no link.  For a passive interface: the light is always on.

Use the following table to understand the optical parameters of the fiber interfaces.

**Table 7-80 10GBASE MMSR and SMLR NetMod Optical Parameters**

Parameter	10GBASE MMSR	10GBASE SMLR
Optical connectors	LC duplex	LC duplex
Bit rate	10.000Gbps	10.000Gbps
Baud rate/ encoding/tolerance	10.3125Gbps 64/66b encoding +/- 100 ppm	10.3125Gbps 64/66b encoding +/- 100 ppm
Optical interface	Multimode	Single mode only
Operating distance	840-860 nm (850 nm typical)  85 ft (26 m) to 108 ft (33 m) for 62.5 μm/125 μm fiber (modal BW 160 to 200 respectively)  216 ft (66 m) to 269 ft (82 m) for 50 μm/125 μm fiber (modal BW 400 to 500 respectively)  Distances to 980 ft (300 m) are available with higher quality (OM3) fiber.  Minimum distances (all): 6ft (2 m)	1270-1355 nm (1310 nm typical)  6 ft to 6.2 miles (2 m to 10 km) for 9 μm/125 μm fiber
Transmitter wavelength	840-860 nm (850 nm typical)	1270-1355 nm (1310 nm typical)
Maximum average launch power	-1 dBm	-0.5 dBm

**Table 7-80** 10GBASE MMSR and SMLR NetMod Optical Parameters (continued)

Parameter	10GBASE MMSR	10GBASE SMLR
Minimum average launch power	-7.3 dBm	-8.2 dBm
Maximum average power at receiver	-1 dBm	-0.5 dBm
Receiver sensitivity	-9.9 dBm	-14.4 dBm

## Stacking Module

The stacking module contains two connection ports for the 8000 Series stacking cable, and activity and link LEDs.

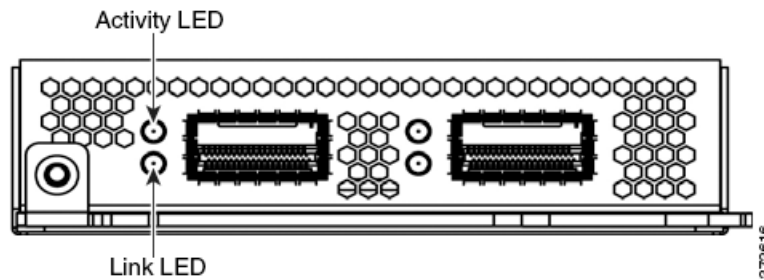

Use the following table to understand the stacking LEDs. Note that the stacking module is available for the 3D8140, 3D8250 and 3D8350, and is included in the 3D8260/3D8270/3D8290 and 3D8360/3D8370/3D8390.

**Table 7-81** Stacking LEDs

Status	Description
Top	Indicates activity on the interface: <ul style="list-style-type: none"> <li>• A blinking light indicates there is activity on the interface.</li> <li>• No light indicates there is no activity.</li> </ul>
Bottom	Indicates whether the interface has link: <ul style="list-style-type: none"> <li>• A light indicates the interface has link.</li> <li>• No light indicates there is no link.</li> </ul>

