



CHAPTER 2

Installing IPS-4240 and IPS-4255

**Note**

All IPS platforms allow ten concurrent CLI sessions.

This chapter describes IPS-4240 and IPS-4255 and how to install them. It also describes the accessories and how to install them. This chapter contains the following sections:

- [Introducing IPS-4240 and IPS-4255, page 2-1](#)
- [Front and Back Panel Features, page 2-2](#)
- [Specifications, page 2-4](#)
- [Connecting IPS-4240 to a Cisco 7200 Series Router, page 2-5](#)
- [Accessories, page 2-5](#)
- [Important Safety Instructions, page 2-5](#)
- [Rack Mounting, page 2-6](#)
- [Installing IPS-4240 and IPS-4255, page 2-7](#)
- [Installing IPS-4240-DC, page 2-10](#)

Introducing IPS-4240 and IPS-4255

**Note**

IPS-4240 and the IPS-4255 do not support redundant power supplies.

IPS-4240 and IPS-4255 deliver high port density in a small form factor. They use a compact flash device for storage rather than the hard-disk drives used in other sensor models.

IPS-4240 replaces IDS-4235. There are four 10/100/1000 copper sensing interfaces. IPS-4240 is available with either AC or DC power. It monitors up to 250 Mbps of aggregate network traffic on multiple sensing interfaces and is inline ready. The 250-Mbps performance for IPS-4240 is based on the following conditions:

- 2500 new TCP connections per second
- 2500 HTTP transactions per second

- Average packet size of 445 bytes
- Running Cisco IPS 5.1 or later



Note The 250-Mbps performance is traffic combined from all four sensing interfaces.

IPS-4255 replaces IDS-4250-TX. There are four 10/100/1000 copper sensing interfaces. It monitors up to 600 Mbps of aggregate network traffic on multiple sensing interfaces and is also inline ready. The 600-Mbps performance for IPS-4255 is based on the following conditions:

- 6000 new TCP connections per second
- 6000 HTTP transactions per second
- Average packet size of 445 bytes
- Running Cisco IPS 5.1 or later



Note The 600-Mbps performance is traffic combined from all four sensing interfaces.

Front and Back Panel Features



Note

Although the illustrations show IPS-4240, the IPS-4255 has the same front and back panel features and indicators.

This section describes the IPS-4240 and IPS-4255 front and back panel features and indicators.

Figure 2-1 shows the front view of IPS-4240 and IPS-4255.

Figure 2-1 *IPS-4240/IPS-4255 Front Panel Features*

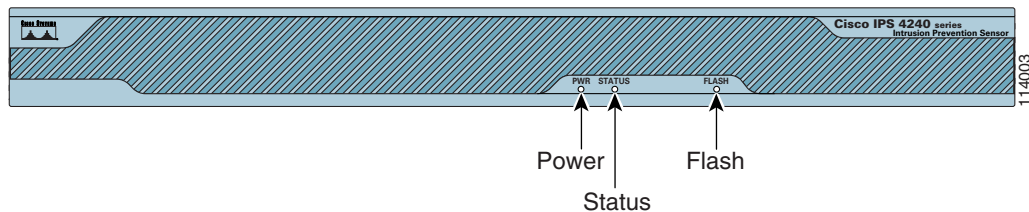

Table 2-1 describes the front panel indicators on IPS-4240 and IPS-4255.

Table 2-1 Front Panel Indicators

Indicator	Description
Power	Off indicates no power. Green when the power supply is running.
Status	Blinks green while the power-up diagnostics are running or the system is booting. Solid green when the system has passed power-up diagnostics. Solid amber when the power-up diagnostics have failed.
Flash	Off when the compact flash device is not being accessed. Blinks green when the compact flash device is being accessed.

Figure 2-2 shows the back view of the IPS-4240 and IPS-4255.

Figure 2-2 IPS-4240 and IPS-4255 Back Panel Features

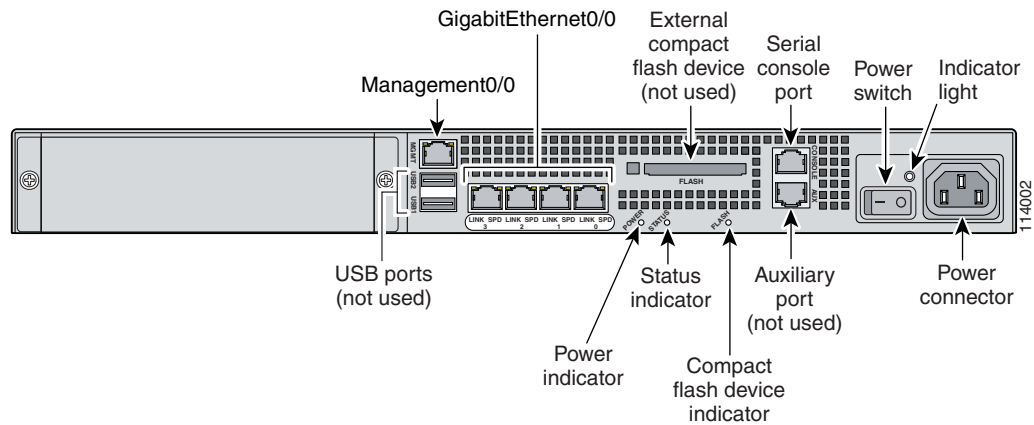

Figure 2-3 shows the four built-in Ethernet ports, which have two indicators per port.

Figure 2-3 Ethernet Port Indicators

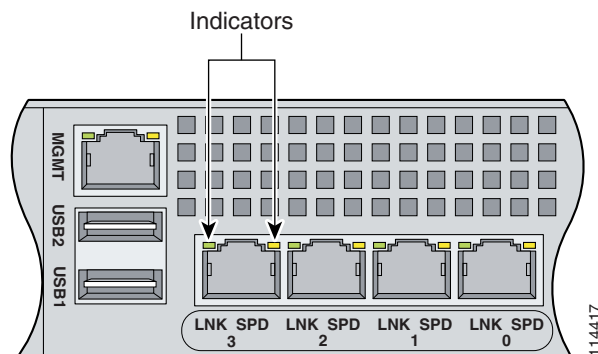

Table 2-2 lists the back panel indicators.

Table 2-2 Back Panel Indicators

Indicator	Color	Description
Left side	Green solid Green blinking	Physical link Network activity
Right side	Not lit Green Amber	10 Mbps 100 Mbps 1000 Mbps

Specifications

Table 2-3 lists the specifications for IPS-4240 and IPS-4255.

Table 2-3 IPS-4240 and IPS-4255 Specifications

Dimensions and Weight	
Height	1.75 in. (4.45 cm)
Width	17.5 in. (44.45 cm)
Depth	14.5 in. (36.83 cm)
Weight	20.0 lb (9.07 kg)
Form factor	1 RU, standard 19-inch rack-mountable
Expansion	One chassis expansion slot (not used)
Power	
Autoswitching	100V to 240V AC
Frequency	47 to 63 Hz, single phase
Operating current	3.0 A
Steady state	150 W
Maximum peak	190 W
Maximum heat dissipation	648 BTU/hr, full power usage (65 W)
Environment	
Temperature	Operating +32°F to +104°F (+0°C to +40°C) Nonoperating -13°F to +158°F (-25°C to +70°C)
Relative humidity	Operating 5% to 95% (noncondensing) Nonoperating 5% to 95% (noncondensing)
Altitude	Operating 0 to 9843 ft (3000 m) Nonoperating 0 to 15,000 ft (4750 m)
Shock	Operating 1.14 m/sec (45 in./sec) ½ sine input Nonoperating 30 G
Vibration	0.41 Grms ² (3 to 500 Hz) random input
Acoustic noise	60 dBa (maximum)

Connecting IPS-4240 to a Cisco 7200 Series Router

When an IPS-4240 is connected directly to a 7200 series router and both the IPS-4240 and the router interfaces are hard-coded to speed 100 with duplex Full, the connection does not work. If you set IPS-4240 to speed Auto and duplex Auto, it connects to the router but only at speed 100 and duplex Half.

To connect correctly at speed 100 and duplex Full, set the interfaces of both IPS-4240 and the router to speed Auto and duplex Auto. Also, if either interface is hard-coded, you must make the connection using a crossover cable.

Accessories

IPS-4240 and IPS-4255 accessories kit contains the following:

- DB25 connector
- DB9 connector
- Rack mounting kit—screws, washers, and metal bracket
- RJ45 console cable
- Two 6-ft Ethernet cables

Important Safety Instructions



IMPORTANT SAFETY INSTRUCTIONS

This warning symbol means danger. You are in a situation that could cause bodily injury. Before you work on any equipment, be aware of the hazards involved with electrical circuitry and be familiar with standard practices for preventing accidents. Use the statement number provided at the end of each warning to locate its translation in the translated safety warnings that accompanied this device. Statement 1071

SAVE THESE INSTRUCTIONS



Only trained and qualified personnel should be allowed to install, replace, or service this equipment. Statement 1030

Rack Mounting

To rack mount IPS-4240 and IPS-4255, follow these steps:

- Step 1** Attach the bracket to the appliance using the supplied screws.
You can attach the brackets to the holes near the front of the appliance.

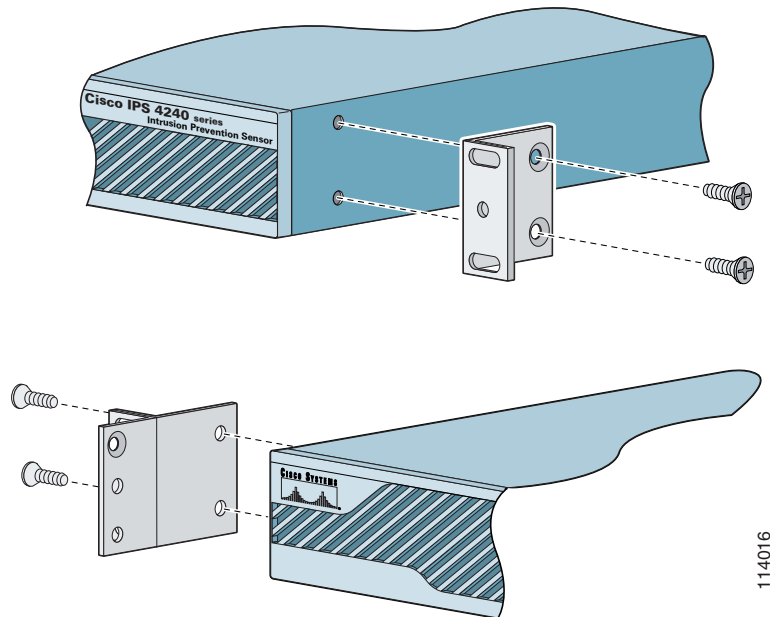

Note The top hole on the left bracket is a banana jack you can use for ESD grounding purposes when you are servicing the system. You can use the two threaded holes to mount a ground lug to ground the chassis.

Step 2 Use the supplied screws to attach the appliance to the equipment rack.

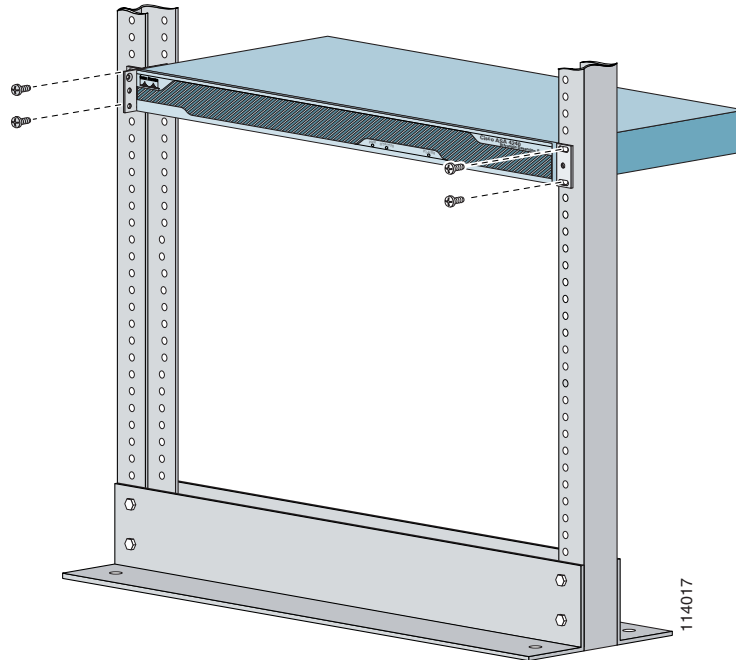

Step 3 To remove the appliance from the rack, remove the screws that attach the appliance to the rack, and then remove the appliance.

Installing IPS-4240 and IPS-4255

Warning

**Only trained and qualified personnel should be allowed to install, replace, or service this equipment.
Statement 1030**

Caution

Follow proper safety procedures when performing these steps by reading the safety warnings in *Regulatory Compliance and Safety Information for the Cisco Intrusion Prevention System 4200 Series Appliance Sensor*.

To install IPS-4240 and IPS-4255 on the network, follow these steps:

-
- Step 1** Position the appliance on the network.
- Step 2** Attach the grounding lug to the side of the appliance.

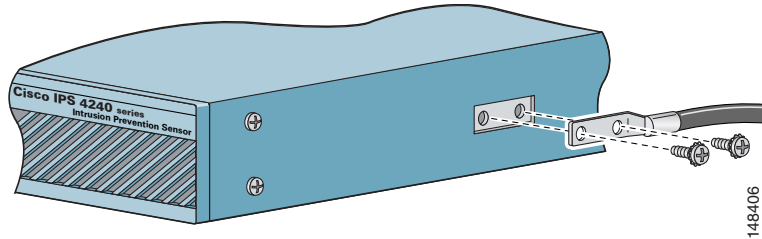

Note Use 8-32 screws to connect a copper standard barrel grounding lug to the holes. The appliance requires a lug where the distance between the center of each hole is 0.56 inches. The ground lug must be NRTL listed or recognized. In addition, the copper conductor (wires) must be used and the copper conductor must comply with the NEC code for ampacity. A lug is not supplied with the appliance.

- Step 3** Place the appliance in a rack, if you are rack mounting it.
- Step 4** Attach the power cord to the appliance and plug it in to a power source (a UPS is recommended).
- Step 5** Connect the cable as shown in Step 6 so that you have either a DB-9 or DB-25 connector on one end as required by the serial port for your computer, and the other end is the RJ-45 connector.



Note Use the console port to connect to a computer to enter configuration commands. Locate the serial cable from the accessory kit. The serial cable assembly consists of a 180/rollover cable with RJ-45 connectors (DB-9 connector adapter PN 74-0495-01 and DB-25 connector adapter PN 29-0810-01).



Note You can use a 180/rollover or straight-through patch cable to connect the appliance to a port on a terminal server with RJ-45 or hydra cable assembly connections. Connect the appropriate cable from the console port on the appliance to a port on the terminal server.

- Step 6** Connect the RJ-45 connector to the console port and connect the other end to the DB-9 or DB-25 connector on your computer.

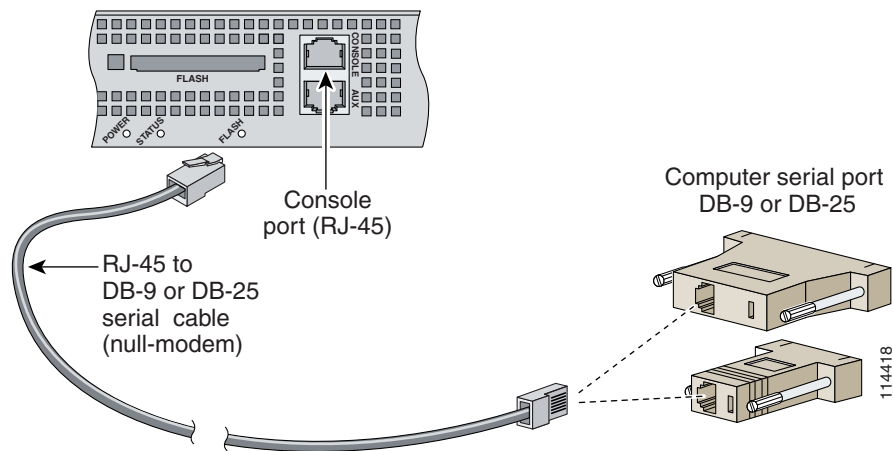

- Step 7** Attach the network cables to the correct ports:

- GigabitEthernet0/0, GigabitEthernet0/1, GigabitEthernet0/2, and GigabitEthernet0/3 (from right to left) are sensing ports.
- Management0/0 is the command and control port.

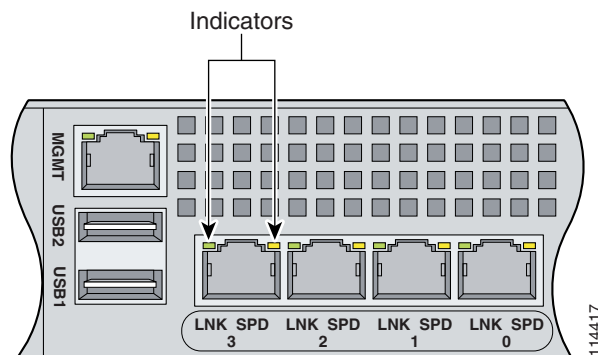

Caution

Management and console ports are privileged administrative ports. Connecting them to an untrusted network can create security concerns.

- Step 8** Power on the appliance.
- Step 9** Initialize the appliance.
- Step 10** Upgrade the appliance with the most recent Cisco IPS software.
- You are now ready to configure intrusion prevention on the appliance.

For More Information

- DC power guidelines are listed in [Regulatory Compliance and Safety Information for the Cisco Intrusion Detection and Prevention System 4200 Series Appliance Sensor](#).
- For more information on working with electrical power and in an ESD environment, see [Site and Safety Guidelines, page 1-32](#).
- For the procedure for placing IPS-4250-DC in a rack, see [Rack Mounting, page 2-6](#).
- For the instructions for setting up a terminal server, see [Connecting an Appliance to a Terminal Server, page 1-19](#).
- For the procedure for using the **setup** command to initialize IPS-4250-DC, see [Basic Sensor Setup, page 10-3](#).
- For the procedure for updating IPS-4250-DC with the most recent cisco IPS software, see [Obtaining Cisco IPS Software, page 12-1](#).
- If you have the IPS-4240 DC model, see [Installing IPS-4240-DC, page 2-10](#).
- For the procedure for using HTTPS to log in to IDM, refer to [Logging In to IDM](#).
- For the procedures for configuring intrusion prevention on your sensor, refer to the following documents:
 - [Installing and Using Cisco Intrusion Prevention System Device Manager 6.2](#)
 - [Installing and Using Cisco Intrusion Prevention System Manager Express 6.2](#)
 - [Configuring the Cisco Intrusion Prevention System Sensor Using the Command Line Interface 6.2](#)

Installing IPS-4240-DC

The IPS-4240-DC-K9 (NEBS-compliant) model equipped with DC-input power supply must be terminated with the DC input wiring on a DC source capable of supplying at least 15 amps. A 15-amp circuit breaker is required at the 48 VDC facility power source. An easily accessible disconnect device should be incorporated into the facility wiring.

**Warning**

Before performing any of the following procedures, ensure that power is removed from the DC circuit. To ensure that all power is OFF, locate the circuit breaker on the panel board that services the DC circuit, switch the circuit breaker to the OFF position, and tape the switch handle of the circuit breaker in the OFF position.

**Note**

The DC return connection should remain isolated from the system frame and chassis (DC-I). This equipment is suitable for connection to intra-building wiring only.

**Warning**

Only trained and qualified personnel should be allowed to install, replace, or service this equipment. Statement 1030

To install IPS-4240-DC, follow these steps:

- Step 1** Position IPS-4240-DC on the network.
- Step 2** Attach the grounding lug to the side of the appliance.

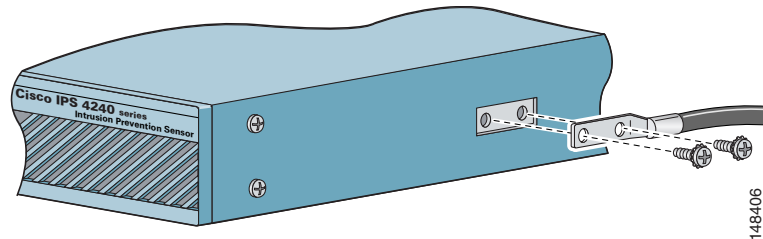

Note

Use 8-32 screws to connect a copper standard barrel grounding lug to the holes. The appliance requires a lug where the distance between the center of each hole is 0.56 inches. The ground lug must be NRTL listed or recognized. In addition, the copper conductor (wires) must be used and the copper conductor must comply with the NEC code for ampacity. A lug is not supplied with the appliance.

- Step 3** Place the appliance in a rack, if you are rack mounting it.
- Step 4** Terminate the DC input wiring on a DC source capable of supplying at least 15 amps.
A 15-amp circuit breaker is required at the 48-VDC facility power source. An easily accessible disconnect device should be incorporated into the facility wiring.
- Step 5** Locate the DC-input terminal box.
- Step 6** Power off IPS-4240-DC.
Make sure that power is removed from the DC circuit. To make sure all power is OFF, locate the circuit breaker on the panel board that services the DC circuit, switch the circuit breaker to the OFF position, and tape the switch handle of the circuit breaker in the OFF position.
- Step 7** Remove the DC power supply plastic shield.

Step 8 Strip the ends of the wires for insertion into the power connect lugs on IPS-4240-DC.

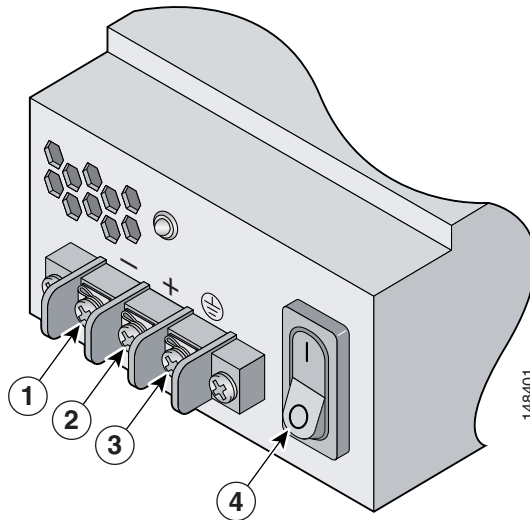

Step 9 Insert the ground wire into the connector for the earth ground and tighten the screw on the connector. Using the same method as for the ground wire, connect the negative wire and then the positive wire.

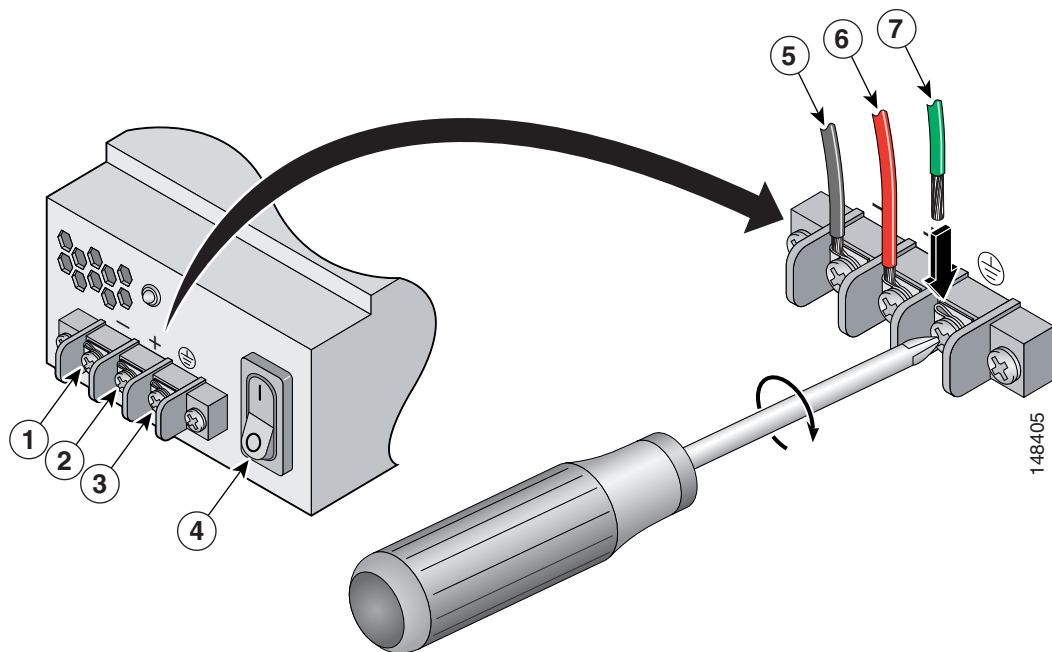

1	Negative	5	Negative
2	Positive	6	Positive
3	Ground	7	Ground
4	On/Off Switch		



Note The DC return connection to this system is to remain isolated from the system frame and chassis.

Step 10 After wiring the DC power supply, remove the tape from the circuit breaker switch handle and reinstate power by moving the handle of the circuit breaker to the ON position.

Step 11 Replace the DC power supply plastic shield.

Step 12 Power on IPS-4240-DC from the switch at the back of the chassis.



Note If you need to power cycle IPS-4240-DC, wait at least 5 seconds between powering it off and powering it back on.

Step 13 Initialize IPS-4240-DC.

Step 14 Upgrade IPS-4240-DC with the most recent Cisco IPS software.

You are now ready to configure intrusion prevention on the appliance.

For More Information

- DC power guidelines are listed in [Regulatory Compliance and Safety Information for the Cisco Intrusion Prevention System 4200 Series Appliance Sensor](#).
- For more information on working with electrical power and in an ESD environment, see [Site and Safety Guidelines, page 1-32](#).
- For the procedure for placing IPS-4250-DC in a rack, see [Rack Mounting, page 2-6](#).
- For the procedure for using the **setup** command to initialize IPS-4250-DC, see [Basic Sensor Setup, page 10-3](#).
- For the procedure for updating IPS-4250-DC with the most recent cisco IPS software, see [Obtaining Cisco IPS Software, page 12-1](#).
- For the procedure for using HTTPS to log in to IDM, refer to [Logging In to IDM](#).
- For the procedures for configuring intrusion prevention on your sensor, refer to the following guides:
 - [Installing and Using Cisco Intrusion Prevention System Device Manager 6.2](#)
 - [Installing and Using Cisco Intrusion Prevention System Manager Express 6.2](#)
 - [Configuring the Cisco Intrusion Prevention System Sensor Using the Command Line Interface 6.2](#)

