



## Configuring Layer 3 Interfaces

---

- [Information About Layer 3 Interfaces, on page 1](#)
- [Guidelines and Limitations for Layer 3 Interfaces, on page 5](#)
- [Default Settings for Layer 3 Interfaces, on page 6](#)
- [SVI Autostate Disable, on page 6](#)
- [DHCP Client Discovery, on page 6](#)
- [MAC-Embedded IPv6 Address, on page 7](#)
- [Configuring Layer 3 Interfaces, on page 7](#)
- [Verifying the Layer 3 Interfaces Configuration, on page 23](#)
- [Triggering the Layer 3 Interface Consistency Checker, on page 24](#)
- [Monitoring Layer 3 Interfaces, on page 25](#)
- [Configuration Examples for Layer 3 Interfaces, on page 26](#)
- [Example of Changing VRF Membership for an Interface, on page 27](#)
- [Related Documents for Layer 3 Interfaces, on page 28](#)
- [MIBs for Layer 3 Interfaces, on page 29](#)
- [Standards for Layer 3 Interfaces, on page 29](#)
- [Feature History for Layer 3 Interfaces, on page 29](#)

## Information About Layer 3 Interfaces

Layer 3 interfaces forward packets to another device using static or dynamic routing protocols. You can use Layer 3 interfaces for IP routing and inter-VLAN routing of Layer 2 traffic.

### Routed Interfaces

You can configure a port as a Layer 2 interface or a Layer 3 interface. A routed interface is a physical port that can route IP traffic to another device. A routed interface is a Layer 3 interface only and does not support Layer 2 protocols, such as the Spanning Tree Protocol (STP).

All Ethernet ports are Layer 2 (switchports) by default. You can change this default behavior using the **no switchport** command from interface configuration mode. To change multiple ports at one time, you can specify a range of interfaces and then apply the **no switchport** command.

You can assign an IP address to the port, enable routing, and assign routing protocol characteristics to this routed interface.

You can assign a static MAC address to a Layer 3 interface. The default MAC address for a Layer 3 interface is the MAC address of the virtual device context (VDC) that is associated with it. You can change the default MAC address of the Layer 3 interface by using the **mac-address** command from the interface configuration mode. A static MAC address can be configured on SVI, Layer 3 interfaces, port channels, Layer 3 subinterfaces, and tunnel interfaces. You can also configure static MAC addresses on a range of ports and port channels. However, all ports must be in Layer 3. Even if one port in the range of ports is in Layer 2, the command is rejected and an error message appears. For information on configuring MAC addresses, see the Layer 2 Switching Configuration Guide for your device.

You can also create a Layer 3 port channel from routed interfaces.

Routed interfaces and subinterfaces support exponentially decayed rate counters. Cisco NX-OS tracks the following statistics with these averaging counters:

- Input packets/sec
- Output packets/sec
- Input bytes/sec
- Output bytes/sec

## Subinterfaces

You can create virtual subinterfaces on a parent interface configured as a Layer 3 interface. A parent interface can be a physical port or a port channel.

Subinterfaces divide the parent interface into two or more virtual interfaces on which you can assign unique Layer 3 parameters such as IP addresses and dynamic routing protocols. The IP address for each subinterface should be in a different subnet from any other subinterface on the parent interface.

You create a subinterface with a name that consists of the parent interface name (for example, Ethernet 2/1) followed by a period and then by a number that is unique for that subinterface. For example, you could create a subinterface for Ethernet interface 2/1 named Ethernet 2/1.1 where .1 indicates the subinterface.

Cisco NX-OS enables subinterfaces when the parent interface is enabled. You can shut down a subinterface independent of shutting down the parent interface. If you shut down the parent interface, Cisco NX-OS shuts down all associated subinterfaces as well.

One use of subinterfaces is to provide unique Layer 3 interfaces to each VLAN that is supported by the parent interface. In this scenario, the parent interface connects to a Layer 2 trunking port on another device. You configure a subinterface and associate the subinterface to a VLAN ID using 802.1Q trunking.

The following figure shows a trunking port from a switch that connects to router B on interface E 2/1. This interface contains three subinterfaces that are associated with each of the three VLANs that are carried by the trunking port.

**Figure 1: Subinterfaces for VLANs**

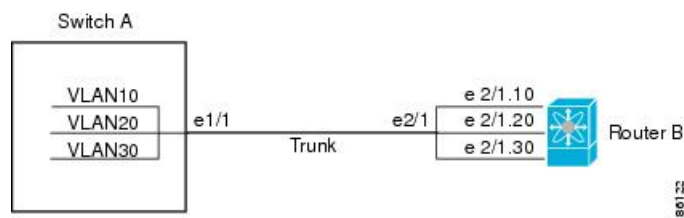

## VLAN Interfaces

A VLAN interface or a switch virtual interface (SVI) is a virtual routed interface that connects a VLAN on the device to the Layer 3 router engine on the same device. Only one VLAN interface can be associated with a VLAN, but you need to configure a VLAN interface for a VLAN only when you want to route between VLANs or to provide IP host connectivity to the device through a virtual routing and forwarding (VRF) instance that is not the management VRF. When you enable VLAN interface creation, Cisco NX-OS creates a VLAN interface for the default VLAN (VLAN 1) to permit remote switch administration.

You must enable the VLAN network interface feature before you can configure it. The system automatically takes a checkpoint prior to disabling the feature, and you can roll back to this checkpoint. For information about rollbacks and checkpoints, see the System Management Configuration Guide for your device.



**Note** You cannot delete the VLAN interface for VLAN 1.

You can route across VLAN interfaces to provide Layer 3 inter-VLAN routing by configuring a VLAN interface for each VLAN that you want to route traffic to and assigning an IP address on the VLAN interface. For more information on IP addresses and IP routing, see the Unicast Routing Configuration Guide for your device.

The following figure shows two hosts connected to two VLANs on a device. You can configure VLAN interfaces for each VLAN that allows Host 1 to communicate with Host 2 using IP routing between the VLANs. VLAN 1 communicates at Layer 3 over VLAN interface 1 and VLAN 10 communicates at Layer 3 over VLAN interface 10.

**Figure 2: Connecting Two VLANs with VLAN Interfaces**

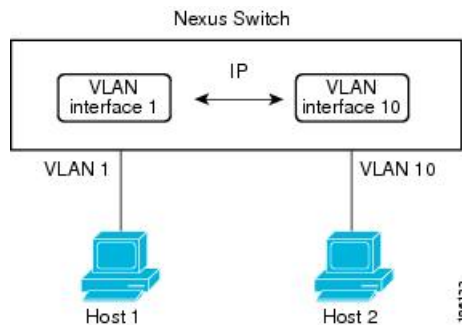

## Changing VRF Membership for an Interface

When you enter the **vrf member** command under an interface, you receive an alert regarding the deletion of interface configurations and to notify the clients/listeners (such as CLI-Server) to delete configurations with respect to the interface.

Entering the **system vrf-member-change retain-l3-config** command enables the retention of the Layer 3 configuration when the VRF member changes on the interface. It does this by sending notification to the clients/listeners to store (buffer) the existing configurations, delete the configurations from the old vrf context, and reapply the stored configurations under the new VRF context.



---

**Note** When the **system vrf-member-change retain-l3-config** command is enabled, the Layer 3 configuration is not deleted and remains stored (buffered). When this command is not enabled (default mode), the Layer 3 configuration is not retained when the VRF member changes.

---

You can disable the retention of the Layer 3 configuration with the **no system vrf-member-change retain-l3-config** command. In this mode, the Layer 3 configuration is not retained when the VRF member changes.

## Notes About Changing VRF Membership for an Interface

- Momentary traffic loss may occur when changing the VRF name.
- Only the configurations under the interface level are processed when the **system vrf-member-change retain-l3-config** command is enabled. You must manually process any configurations at the router level to accommodate routing protocols after a VRF change.
- The **system vrf-member-change retain-l3-config** command supports interface level configurations with:
  - Layer 3 configurations maintained by the CLI Server, such as **ip address** and **ipv6 address** (secondary) and all OSPF/ISIS/EIGRP CLIs available under the interface configuration.
  - HSRP
  - DHCP Relay Agent CLIs, such as **ip dhcp relay address [use-vrf]** and **ipv6 dhcp relay address [use-vrf]**.
- For DHCP:
  - As a best practice, the client and server interface VRF should be changed one at a time. Otherwise, the DHCP packets cannot be exchanged on the relay agent.
  - When the client and server are in different VRFs, use the **ip dhcp relay address [use-vrf]** command to exchange the DHCP packets in the relay agent over the different VRFs.

## Loopback Interfaces

A loopback interface is a virtual interface with a single endpoint that is always up. Any packet that is transmitted over a loopback interface is immediately received by this interface. Loopback interfaces emulate a physical interface.

You can use loopback interfaces for performance analysis, testing, and local communications. Loopback interfaces can act as a termination address for routing protocol sessions. This loopback configuration allows routing protocol sessions to stay up even if some of the outbound interfaces are down.

## IP Unnumbered

The IP unnumbered feature enables the processing of IP packets on a point to point (p2p) interface without explicitly configuring a unique IP address on it. This approach borrows an IP address from another interface and conserves address space on point to point links.

Any interface which conforms to the point to point mode can be used as an IP unnumbered interface. For 7.0(3)I3(1) and later, the IP unnumbered feature is supported only on Ethernet interfaces and sub-interfaces. The borrowed interface can only be a loopback interface and is known as the numbered interface.

A loopback interface is ideal as a numbered interface in that it is always functionally up. However, because loopback interfaces are local to a switch/router, the reachability of unnumbered interfaces first needs to be established through static routes or by using an interior gateway protocol, such as OSPF or ISIS.

Starting from 7.0(3)I5(1), IP unnumbered feature is supported on port channel interfaces and sub-interfaces. The borrowed interface can only be a loopback interface and is known as the numbered interface.

## Tunnel Interfaces

Cisco NX-OS supports tunnel interfaces as IP tunnels. IP tunnels can encapsulate a same- layer or higher layer protocol and transport the result over IP through a tunnel that is created between two routers.

## Guidelines and Limitations for Layer 3 Interfaces

Layer 3 interfaces have the following configuration guidelines and limitations:

- When an IP unnumbered interface is configured, a loopback interface should be in the same VRF as the IP unnumbered interface.
- An admin-shutdown command on a loopback interface that is a numbered interface does not bring down the IP unnumbered interface. This means that the routing protocols running over the IP unnumbered interface continue to be up.
- The static routes running over the IP unnumbered interface should use pinned static routes.



---

**Note** The IP unnumbered interface through which the route is resolved needs to be specified.

---

- Medium p2p should be enabled for configuring the IP unnumbered feature.
- The VLAN/SVI is not removed from the Layer 3 interface table, after the configuration is removed. The VLAN itself should be removed from the Layer 3 interface table.
- If you change a Layer 3 interface to a Layer 2 interface, Cisco NX-OS shuts down the interface, reenables the interface, and removes all configuration specific to Layer 3.
- If you change a Layer 2 interface to a Layer 3 interface, Cisco NX-OS shuts down the interface, reenables the interface, and deletes all configuration specific to Layer 2.
- Configuring a subinterface on a physical interface that is configured to be a member of a port-channel is not supported. One must configure the subinterface under the port-channel interface itself.

- Cisco Nexus 3000 Series switches punt multicast Layer 2 traffic to the CPU if the Layer 3 MTU is not the same for all Layer 3 interfaces, and if the MTU QoS was changed to jumbo. All Layer 3 interfaces must have the same Layer 3 MTU to avoid this issue.

## Default Settings for Layer 3 Interfaces

The default setting for the Layer 3 Admin state is Shut.

## SVI Autostate Disable

The SVI Autostate Disable feature enables the Switch Virtual Interface (SVI) to be in the “up” state even if no interface is in the “up” state in the corresponding VLAN.

An SVI is also a virtual routed interface that connects a VLAN on the device to the Layer 3 router engine on the same device. The ports in a VLAN determine the operational state of the corresponding SVI. An SVI interface on a VLAN comes “up” when at least one port in the corresponding VLAN is in the Spanning Tree Protocol (STP) forwarding state. Similarly, the SVI interface goes “down” when the last STP forwarding port goes down or to any other state. This characteristic of SVI is called 'Autostate'.

You can create SVIs to define Layer 2 or Layer 3 boundaries on VLANs, or use the SVI interface to manage devices. In the second scenario, the SVI Autostate Disable feature ensures that the SVI interface is in the “up” state even if no interface is in the “up” state in the corresponding VLAN.

## DHCP Client Discovery

Cisco NX-OS Release 6.0(2)U3(1) introduced DHCP client discovery on SVIs. Cisco NX-OS Release 6.0(2)U4(1) adds DHCP client discovery support for IPv6 addresses and physical Ethernet and management interfaces. You can configure the IP address of a DHCP client by using the **ip address dhcp** or **ipv6 address dhcp** command. These commands send a request from the DHCP client to the DHCP server soliciting an IPv4 or IPv6 address from the DHCP server. The DHCP client on the Cisco Nexus switch identifies itself to the DHCP server. The DHCP server uses this identifier to send the IP address back to the DHCP client.

When a DHCP client is configured on the SVI with the DHCP server sending router and DNS options, the **ip route 0.0.0.0/0 router-ip** and **ip name-server dns-ip** commands are configured on the switch automatically.

If the switch is reloaded and, at the same time, the router and DNS options are disabled on the server side, after the switch comes up, a new IP address is assigned to the SVI. However, the stale **ip route** command and **ip name-server** command will still exist in the switch configuration. You must manually remove these commands from the configuration.

## Limitations for Using DHCP Client Discovery on Interfaces

The following are the limitations for using DHCP client discovery on interfaces:

- This feature is supported only on physical Ethernet interfaces, management interfaces, and SVIs.
- Starting with Cisco NX-OS Release 6.0(2)U4(1), this feature is supported on non-default virtual routing and forwarding (VRF) instances as well.

- The DNS server and default router option-related configurations are saved in the startup configuration when you enter the **copy running-config startup-config** command. When you reload the switch, if this configuration is not applicable, you might have to remove it.
- You can configure a maximum of six DNS servers on the switch, which is a switch limitation. This maximum number includes the DNS servers configured by the DHCP client and the DNS servers configured manually.
- If the number of DNS servers configured on the switch is more than six, and if you get a DHCP offer for an SVI with DNS option set, the IP address is not assigned to the SVI.

## MAC-Embedded IPv6 Address

Beginning with Cisco NX-OS Release 6.0(2)U4(1), BGP allows an IPv4 prefix to be carried over an IPv6 next-hop. The IPv6 next-hop is leveraged to remove neighbor discovery (ND) related traffic from the network. To do this, the MAC address is embedded in the IPv6 address. Such an address is called a MAC Embedded IPv6 (MEv6) address. The router extracts the MAC address directly from the MEv6 address instead of going through ND. Local interface and next-hop MAC addresses are extracted from the IPv6 addresses.

On MEv6-enabled IPv6 interfaces, the same MEv6 extracted MAC address is used for IPv4 traffic as well. MEv6 is supported on all Layer 3 capable interfaces except SVIs.



---

**Important** When MEv6 is enabled on an interface, ping6 to the IPv6 link local address, OSPFv3, and BFDv6 are not supported on that interface.

---

## Configuring Layer 3 Interfaces

### Configuring a Routed Interface

#### SUMMARY STEPS

1. switch# **configure terminal**
2. switch(config)# **interface ethernet slot/port**
3. switch(config-if)# **no switchport**
4. switch(config-if)# [**ip|ipv6**]ip-address/length
5. (Optional) switch(config-if)# **medium {broadcast | p2p}**
6. (Optional) switch(config-if)# **show interfaces**
7. (Optional) switch(config-if)# **copy running-config startup-config**

#### DETAILED STEPS

	Command or Action	Purpose
Step 1	switch# <b>configure terminal</b>	Enters global configuration mode.

	Command or Action	Purpose
<b>Step 2</b>	switch(config)# <b>interface ethernet</b> <i>slot/port</i>	Enters interface configuration mode.
<b>Step 3</b>	switch(config-if)# <b>no switchport</b>	Configures the interface as a Layer 3 interface and deletes any configuration specific to Layer 2 on this interface.  <b>Note</b> To convert a Layer 3 interface back into a Layer 2 interface, use the <b>switchport</b> command.
<b>Step 4</b>	switch(config-if) # [ <b>ip ipv6</b> ] <i>ip-address/length</i>	Configures an IP address for this interface.
<b>Step 5</b>	(Optional) switch(config-if)# <b>medium {broadcast   p2p}</b>	Configures the interface medium as either point to point or broadcast.  <b>Note</b> The default setting is broadcast, and this setting does not appear in any of the <b>show</b> commands. However, if you do change the setting to <b>p2p</b> , you will see this setting when you enter the <b>show running-config</b> command.
<b>Step 6</b>	(Optional) switch(config-if)# <b>show interfaces</b>	Displays the Layer 3 interface statistics.
<b>Step 7</b>	(Optional) switch(config-if)# <b>copy running-config startup-config</b>	Saves the change persistently through reboots and restarts by copying the running configuration to the startup configuration.

### Example

This example shows how to configure an IPv4-routed Layer 3 interface:

```
switch# configure terminal
switch(config)# interface ethernet 2/1
switch(config-if)# no switchport
switch(config-if)# ip address 192.0.2.1/8
switch(config-if)# copy running-config startup-config
```

## Configuring a Subinterface

### Before you begin

- Configure the parent interface as a routed interface.
- Create the port-channel interface if you want to create a subinterface on that port channel.

### SUMMARY STEPS

1. (Optional) switch(config-if)# **copy running-config startup-config**
2. switch(config)# **interface ethernet** *slot/port.number*



3. switch(config-if)# **[ip | ipv6] address** *ip-address/length*
4. switch(config-if)# **encapsulation dot1Q** *vlan-id*
5. (Optional) switch(config-if)# **show interfaces**
6. (Optional) switch(config-if)# **copy running-config startup-config**

## DETAILED STEPS

	Command or Action	Purpose
<b>Step 1</b>	(Optional) switch(config-if)# <b>copy running-config startup-config</b>	Saves the change persistently through reboots and restarts by copying the running configuration to the startup configuration.
<b>Step 2</b>	switch(config)# <b>interface ethernet</b> <i>slot/port.number</i>	Enters interface configuration mode. The range for the <i>slot</i> is from 1 to 255. The range for the <i>port</i> is from 1 to 128.
<b>Step 3</b>	switch(config-if)# <b>[ip   ipv6] address</b> <i>ip-address/length</i>	Configures an IP address for this interface.
<b>Step 4</b>	switch(config-if)# <b>encapsulation dot1Q</b> <i>vlan-id</i>	Configures IEEE 802.1Q VLAN encapsulation on the subinterface. The range for the <i>vlan-id</i> is from 2 to 4093.
<b>Step 5</b>	(Optional) switch(config-if)# <b>show interfaces</b>	Displays the Layer 3 interface statistics.
<b>Step 6</b>	(Optional) switch(config-if)# <b>copy running-config startup-config</b>	Saves the change persistently through reboots and restarts by copying the running configuration to the startup configuration.

### Example

This example shows how to create a subinterface:

```
switch# configure terminal
switch(config)# interface ethernet 2/1
switch(config-if)# ip address 192.0.2.1/8
switch(config-if)# encapsulation dot1Q 33
switch(config-if)# copy running-config startup-config
```

## Configuring the Bandwidth on an Interface

You can configure the bandwidth for a routed interface, port channel, or subinterface.

### SUMMARY STEPS

1. switch# **configure terminal**
2. switch(config)# **interface ethernet** *slot/port*
3. switch(config-if)# **bandwidth** [*value* | **inherit** [*value*]]
4. (Optional) switch(config-if)# **copy running-config startup-config**

## DETAILED STEPS

	Command or Action	Purpose
<b>Step 1</b>	switch# <b>configure terminal</b>	Enters global configuration mode.
<b>Step 2</b>	switch(config)# <b>interface ethernet slot/port</b>	Enters interface configuration mode. The range for the <i>slot</i> is from 1 to 255. The range for the <i>port</i> is from 1 to 128.
<b>Step 3</b>	switch(config-if)# <b>bandwidth [value   inherit [value]]</b>	Configures the bandwidth parameter for a routed interface, port channel, or subinterface, as follows: <ul style="list-style-type: none"> <li>• <i>value</i>—Size of the bandwidth in kilobytes. The range is from 1 to 10000000.</li> <li>• <b>inherit</b>—Indicates that all subinterfaces of this interface inherit either the bandwidth value (if a value is specified) or the bandwidth of the parent interface (if a value is not specified).</li> </ul>
<b>Step 4</b>	(Optional) switch(config-if)# <b>copy running-config startup-config</b>	Saves the change persistently through reboots and restarts by copying the running configuration to the startup configuration.

## Example

This example shows how to configure Ethernet interface 2/1 with a bandwidth value of 80000:

```
switch# configure terminal
switch(config)# interface ethernet 2/1
switch(config-if)# bandwidth 80000
switch(config-if)# copy running-config startup-config
```

## Configuring a VLAN Interface

## SUMMARY STEPS

1. switch# **configure terminal**
2. switch(config)# **feature interface-vlan**
3. switch(config)# **interface vlan number**
4. switch(config-if)# **[ip | ipv6 ] address ip-address/length**
5. switch(config-if)# **no shutdown**
6. (Optional) switch(config-if)# **show interface vlan number**
7. (Optional) switch(config-if)# **copy running-config startup-config**

## DETAILED STEPS

	Command or Action	Purpose
<b>Step 1</b>	switch# <b>configure terminal</b>	Enters global configuration mode.

	Command or Action	Purpose
Step 2	switch(config)# <b>feature interface-vlan</b>	Enables VLAN interface mode.
Step 3	switch(config)# <b>interface vlan</b> <i>number</i>	Creates a VLAN interface. The <i>number</i> range is from 1 to 4094.
Step 4	switch(config-if)# [ <b>ip   ipv6</b> ] <b>address</b> <i>ip-address/length</i>	Configures an IP address for this interface.
Step 5	switch(config-if)# <b>no shutdown</b>	Brings the interface up administratively.
Step 6	(Optional) switch(config-if)# <b>show interface vlan</b> <i>number</i>	Displays the VLAN interface statistics. The <i>number</i> range is from 1 to 4094.
Step 7	(Optional) switch(config-if)# <b>copy running-config startup-config</b>	Saves the change persistently through reboots and restarts by copying the running configuration to the startup configuration.

### Example

This example shows how to create a VLAN interface:

```
switch# configure terminal
switch(config)# feature interface-vlan
switch(config)# interface vlan 10
switch(config-if)# ip address 192.0.2.1/8
switch(config-if)# copy running-config startup-config
```

## Enabling Layer 3 Retention During VRF Membership Change

The following steps enable the retention of the Layer 3 configuration when changing the VRF membership on the interface.

### SUMMARY STEPS

1. **configure terminal**
2. **system vrf-member-change retain-l3-config**

### DETAILED STEPS

	Command or Action	Purpose
Step 1	<b>configure terminal</b>  <b>Example:</b>  switch# <b>configure terminal</b> switch(config)#	Enters configuration mode.
Step 2	<b>system vrf-member-change retain-l3-config</b>  <b>Example:</b>	Enables Layer 3 configuration retention during VRF membership change.

	Command or Action	Purpose
	<pre>switch(config)# system vrf-member-change retain-l3-config</pre> <p>Warning: Will retain L3 configuration when vrf member change on interface.</p>	<p><b>Note</b> To disable the retention of the Layer 3 configuration, use the <b>no system vrf-member-change retain-l3-config</b> command.</p>

## Configuring a Loopback Interface

### Before you begin

Ensure that the IP address of the loopback interface is unique across all routers on the network.

### SUMMARY STEPS

1. switch# **configure terminal**
2. switch(config)# **interface loopback** *instance*
3. switch(config-if)# **[ip | ipv6 ] address** *ip-address/length*
4. (Optional) switch(config-if)# **show interface loopback** *instance*
5. (Optional) switch(config-if)# **copy running-config startup-config**

### DETAILED STEPS

	Command or Action	Purpose
<b>Step 1</b>	switch# <b>configure terminal</b>	Enters global configuration mode.
<b>Step 2</b>	switch(config)# <b>interface loopback</b> <i>instance</i>	Creates a loopback interface. The <i>instance</i> range is from 0 to 1023.
<b>Step 3</b>	switch(config-if)# <b>[ip   ipv6 ] address</b> <i>ip-address/length</i>	Configures an IP address for this interface.
<b>Step 4</b>	(Optional) switch(config-if)# <b>show interface loopback</b> <i>instance</i>	Displays the loopback interface statistics. The <i>instance</i> range is from 0 to 1023.
<b>Step 5</b>	(Optional) switch(config-if)# <b>copy running-config startup-config</b>	Saves the change persistently through reboots and restarts by copying the running configuration to the startup configuration.

### Example

This example shows how to create a loopback interface:

```
switch# configure terminal
switch(config)# interface loopback 0
switch(config-if)# ip address 192.0.2.100/8
switch(config-if)# copy running-config startup-config
```

## Configuring IP Unnumbered on an Ethernet Interface

You can configure the IP unnumbered feature on an ethernet interface.

### SUMMARY STEPS

1. **configure terminal**
2. **interface ethernet *slot/port* port-channel**
3. **medium p2p**
4. **ip unnumbered *type number***

### DETAILED STEPS

	Command or Action	Purpose
Step 1	<b>configure terminal</b> <b>Example:</b> <pre>switch# configure terminal switch(config)#</pre>	Enters global configuration mode.
Step 2	<b>interface ethernet <i>slot/port</i> port-channel</b> <b>Example:</b> <pre>switch(config)# interface ethernet 1/1 switch(config-if)#  switch(config)# interface port-channel 1/1 switch(config-if)#</pre>	Enters interface configuration mode. Supports Ethernet and Port-channel
Step 3	<b>medium p2p</b> <b>Example:</b> <pre>switch(config-if)# medium p2p</pre>	Configures the interface medium as point to point.
Step 4	<b>ip unnumbered <i>type number</i></b> <b>Example:</b> <pre>switch(config-if)# ip unnumbered loopback 100</pre>	Enables IP processing on an interface without assigning an explicit IP address to the interface.  <i>type</i> and <i>number</i> specify another interface on which the router has an assigned IP address. The interface specified cannot be another unnumbered interface.  <b>Note</b> <i>type</i> is limited to <b>loopback</b> . (7.0(3)I3(1) and later)

## Configuring OSPF for an IP Unnumbered Interface

You can configure OSPF for an IP unnumbered loopback interface.

### SUMMARY STEPS

1. **configure terminal**
2. **interface ethernet *slot/port***

3. **encapsulation dot1Q** *vlan-id*
4. **medium p2p**
5. **ip unnumbered** *type number*
6. (Optional) **ip ospf authentication**
7. (Optional) **ip ospf authentication-key** *password*
8. **ip router ospf** *instance area area-number*
9. **no shutdown**
10. **interface loopback** *instance*
11. **ip address** *ip-address/length*
12. **ip router ospf** *instance area area-number*

## DETAILED STEPS

	Command or Action	Purpose
<b>Step 1</b>	<b>configure terminal</b> <b>Example:</b> <pre>switch# configure terminal switch(config)#</pre>	Enters global configuration mode.
<b>Step 2</b>	<b>interface ethernet</b> <i>slot/port</i> <b>Example:</b> <pre>switch(config)# interface ethernet 1/20.1 switch(config-if)#</pre>	Enters interface configuration mode.
<b>Step 3</b>	<b>encapsulation dot1Q</b> <i>vlan-id</i> <b>Example:</b> <pre>switch(config-if)# encapsulation dot1Q 100</pre>	Configures IEEE 802.1Q VLAN encapsulation on the subinterface. The range is from 2 to 4093.
<b>Step 4</b>	<b>medium p2p</b> <b>Example:</b> <pre>switch(config-if)# medium p2p</pre>	Configures the interface medium as point to point.
<b>Step 5</b>	<b>ip unnumbered</b> <i>type number</i> <b>Example:</b> <pre>switch(config-if)# ip unnumbered loopback 101</pre>	<p>Enables IP processing on an interface without assigning an explicit IP address to the interface.</p> <p><i>type</i> and <i>number</i> specify another interface on which the router has an assigned IP address. The interface specified cannot be another unnumbered interface.</p> <p><b>Note</b> <i>type</i> is limited to <b>loopback</b>. (7.0(3)I3(1) and later)</p>
<b>Step 6</b>	(Optional) <b>ip ospf authentication</b> <b>Example:</b> <pre>switch(config-if)# ip ospf authentication</pre>	Specifies the authentication type for interface.
<b>Step 7</b>	(Optional) <b>ip ospf authentication-key</b> <i>password</i> <b>Example:</b>	Specifies the authentication password for OSPF authentication.

	Command or Action	Purpose
	<code>switch(config-if)# ip ospf authentication 3 b7bdf15f62bbd250</code>	
<b>Step 8</b>	<p><b>ip router ospf</b> <i>instance area area-number</i></p> <p><b>Example:</b></p> <pre>switch(config-if)# ip router ospf 100 area 0.0.0.1</pre>	<p>Configures routing process for IP on an interface and specifies an area.</p> <p><b>Note</b> The <b>ip router ospf</b> command is required for both the unnumbered and the numbered interface.</p>
<b>Step 9</b>	<p><b>no shutdown</b></p> <p><b>Example:</b></p> <pre>switch(config-if)# no shutdown</pre>	Brings up the interface (administratively).
<b>Step 10</b>	<p><b>interface loopback</b> <i>instance</i></p> <p><b>Example:</b></p> <pre>switch(config)# interface loopback 101</pre>	Creates a loopback interface. The range is from 0 to 1023.
<b>Step 11</b>	<p><b>ip address</b> <i>ip-address/length</i></p> <p><b>Example:</b></p> <pre>switch(config-if)# 192.168.101.1/32</pre>	Configures an IP address for the interface.
<b>Step 12</b>	<p><b>ip router ospf</b> <i>instance area area-number</i></p> <p><b>Example:</b></p> <pre>switch(config-if)# ip router ospf 100 area 0.0.0.1</pre>	<p>Configures routing process for IP on an interface and specifies an area.</p> <p><b>Note</b> The <b>ip router ospf</b> command is required for both the unnumbered and the numbered interface.</p>

## Configuring ISIS for an IP Unnumbered Interface

You can configure ISIS for an IP unnumbered loopback interface.

### SUMMARY STEPS

1. **configure terminal**
2. **feature isis**
3. **router isis** *area-tag*
4. **net** *network-entity-title*
5. **end**
6. **interface ethernet** *slot/port*
7. **encapsulation dot1Q** *vlan-id*
8. **medium p2p**
9. **ip unnumbered** *type number*
10. **ip router isis** *area-tag*
11. **no shutdown**

## DETAILED STEPS

	Command or Action	Purpose
Step 1	<b>configure terminal</b> <b>Example:</b> switch# <b>configure terminal</b> switch(config)#	Enters global configuration mode.
Step 2	<b>feature isis</b> <b>Example:</b> Switch(config)# <b>feature isis</b>	Enables ISIS.
Step 3	<b>router isis area-tag</b> <b>Example:</b> Switch(config)# <b>router isis 100</b>	Assigns a tag to an IS-IS process and enters router configuration mode.
Step 4	<b>net network-entity-title</b> <b>Example:</b> Switch(config-router)# <b>net</b> 49.0001.0100.0100.1001.00	Configures the network entity title (NET) on the device.
Step 5	<b>end</b> <b>Example:</b> Switch(config-router)# <b>end</b>	Exit router configuration mode.
Step 6	<b>interface ethernet slot/port</b> <b>Example:</b> switch(config)# <b>interface ethernet 1/20.1</b>	Enters interface configuration mode.
Step 7	<b>encapsulation dot1Q vlan-id</b> <b>Example:</b> switch(config-subif)# <b>encapsulation dot1Q 100</b>	Configures IEEE 802.1Q VLAN encapsulation on the subinterface. The range is from 2 to 4093.
Step 8	<b>medium p2p</b> <b>Example:</b> switch(config-subif)# <b>medium p2p</b>	Configures the interface medium as point to point.
Step 9	<b>ip unnumbered type number</b> <b>Example:</b> switch(config-if)# <b>ip unnumbered loopback 101</b>	Enables IP processing on an interface without assigning an explicit IP address to the interface.  <i>type</i> and <i>number</i> specify another interface on which the router has an assigned IP address. The interface specified cannot be another unnumbered interface.  <b>Note</b> <i>type</i> is limited to <b>loopback</b> . (7.0(3)I3(1) and later)



	Command or Action	Purpose
<b>Step 10</b>	<b>ip router isis</b> <i>area-tag</i>  <b>Example:</b> switch(config-subif) # <b>ip router isis</b> 100	Enables ISIS on the unnumbered interface.
<b>Step 11</b>	<b>no shutdown</b>  <b>Example:</b> switch(config-subif) # <b>no shutdown</b>	Brings up the interface (administratively).

## Assigning an Interface to a VRF

### Before you begin

Assign the IP address for a tunnel interface after you have configured the interface for a VRF.

### SUMMARY STEPS

1. switch# **configure terminal**
2. switch(config)# **interface** *interface-typenumber*
3. switch(config-if)#**vrf member** *vrf-name*
4. switch(config-if)# [**ip** | **ipv6**]*ip-address/length*
5. (Optional) switch(config-if)# **show vrf** [*vrf-name*] **interface** *interface-type number*
6. (Optional) switch(config-if)# **show interfaces**
7. (Optional) switch(config-if)# **copy running-config startup-config**

### DETAILED STEPS

	Command or Action	Purpose
<b>Step 1</b>	switch# <b>configure terminal</b>	Enters global configuration mode.
<b>Step 2</b>	switch(config)# <b>interface</b> <i>interface-typenumber</i>	Enters interface configuration mode.
<b>Step 3</b>	switch(config-if)# <b>vrf member</b> <i>vrf-name</i>	Adds this interface to a VRF.
<b>Step 4</b>	switch(config-if)# [ <b>ip</b>   <b>ipv6</b> ] <i>ip-address/length</i>	Configures an IP address for this interface. You must do this step after you assign this interface to a VRF.
<b>Step 5</b>	(Optional) switch(config-if)# <b>show vrf</b> [ <i>vrf-name</i> ] <b>interface</b> <i>interface-type number</i>	Displays VRF information.
<b>Step 6</b>	(Optional) switch(config-if)# <b>show interfaces</b>	Displays the Layer 3 interface statistics.
<b>Step 7</b>	(Optional) switch(config-if)# <b>copy running-config startup-config</b>	Saves the change persistently through reboots and restarts by copying the running configuration to the startup configuration.

### Example

This example shows how to add a Layer 3 interface to the VRF:

```
switch# configure terminal
switch(config)# interface loopback 0
switch(config-if)# vrf member RemoteOfficeVRF
switch(config-if)# ip address 209.0.2.1/16
switch(config-if)# copy running-config startup-config
```

## Configuring an Interface MAC Address

You can configure a static MAC address on SVI, Layer 3 interfaces, port channels, Layer 3 subinterfaces, and tunnel interfaces. You can also configure static MAC addresses on a range of ports and port channels. However, all ports must be in Layer 3. Even if one port in the range of ports is in Layer 2, the command is rejected and an error message appears.

### SUMMARY STEPS

1. switch# **configure terminal**
2. switch(config)# **interface ethernet slot/port**
3. switch(config-if)# [**no**] **mac-address static router MAC address**
4. switch(config-if)# **show interface ethernet slot/port**

### DETAILED STEPS

	Command or Action	Purpose
<b>Step 1</b>	switch# <b>configure terminal</b>	Enters global configuration mode.
<b>Step 2</b>	switch(config)# <b>interface ethernet slot/port</b>	Enters interface configuration mode.
<b>Step 3</b>	switch(config-if)# [ <b>no</b> ] <b>mac-address static router MAC address</b>	Configures the interface MAC address. The <b>no</b> form removes the configuration. You can enter the MAC address in any one of the four supported formats: <ul style="list-style-type: none"> <li>• E.E.E</li> <li>• EE-EE-EE-EE-EE-EE</li> <li>• EE:EE:EE:EE:EE:EE</li> <li>• EEEE.EEEE.EEEE</li> </ul> Do not enter any of the following invalid MAC addresses: <ul style="list-style-type: none"> <li>• Null MAC address—0000.0000.0000</li> <li>• Broadcast MAC address—FFFF.FFFF.FFFF</li> <li>• Multicast MAC address—0100.DAAA.ADDD</li> </ul>
<b>Step 4</b>	switch(config-if)# <b>show interface ethernet slot/port</b>	(Optional) Displays all information for the interface.

### Example

This example shows how to configure an interface MAC address:

```

switch# configure terminal
switch(config)# interface ethernet 3/3
switch(config-if)# mac-address aaaa.bbbb.dddd
switch(config-if)# show interface ethernet 3/3
switch(config-if)#

```

## Configuring a MAC-Embedded IPv6 Address

### SUMMARY STEPS

1. switch# **configure terminal**
2. switch(config)# **interface** *type slot/port*
3. switch(config-if)# **no switchport**
4. switch(config-if)# **mac-address ipv6-extract**
5. switch(config-if)# **ipv6 address** *ip-address/length*
6. switch(config-if)# **ipv6 nd mac-extract** [**exclude nud-phase**]
7. (Optional) switch(config)# **show ipv6 icmp interface** *type slot/port*

### DETAILED STEPS

	Command or Action	Purpose
<b>Step 1</b>	switch# <b>configure terminal</b>	Enters global configuration mode.
<b>Step 2</b>	switch(config)# <b>interface</b> <i>type slot/port</i>	Enters the interface configuration mode for the specified interface.
<b>Step 3</b>	switch(config-if)# <b>no switchport</b>	Configures the interface as a Layer 3 interface and deletes any configuration specific to Layer 2 on this interface.  <b>Note</b> To convert a Layer 3 interface back into a Layer 2 interface, use the <b>switchport</b> command.
<b>Step 4</b>	switch(config-if)# <b>mac-address ipv6-extract</b>	Extracts the MAC address embedded in the IPv6 address configured on the interface.  <b>Note</b> The MEv6 configuration is currently not supported with the EUI-64 format of IPv6 address.
<b>Step 5</b>	switch(config-if)# <b>ipv6 address</b> <i>ip-address/length</i>	Configures an IPv6 address for this interface.
<b>Step 6</b>	switch(config-if)# <b>ipv6 nd mac-extract</b> [ <b>exclude nud-phase</b> ]	Extracts the next-hop MAC address embedded in a next-hop IPv6 address.  The <b>exclude nud-phase</b> option blocks packets during the ND phase only. When the <b>exclude nud-phase</b> option is not specified, packets are blocked during both ND and Neighbor Unreachability Detection (NUD) phases.

	Command or Action	Purpose
<b>Step 7</b>	(Optional) switch(config)# <b>show ipv6 icmp interface type slot/port</b>	Displays IPv6 Internet Control Message Protocol version 6 (ICMPv6) interface information.

### Example

This example shows how to configure a MAC-embedded IPv6 address with ND mac-extract enabled:

```
switch# configure terminal
Enter configuration commands, one per line. End with CNTL/Z.
switch(config)# interface ethernet 1/3
switch(config-if)# no switchport
switch(config-if)# mac-address ipv6-extract
switch(config-if)# ipv6 address 2002:1::10/64
switch(config-if)# ipv6 nd mac-extract
switch(config-if)# show ipv6 icmp interface ethernet 1/3
ICMPv6 Interfaces for VRF "default"
Ethernet1/3, Interface status: protocol-up/link-up/admin-up
  IPv6 address: 2002:1::10
  IPv6 subnet: 2002:1::/64
  IPv6 interface DAD state: VALID
  ND mac-extract : Enabled
  ICMPv6 active timers:
    Last Neighbor-Solicitation sent: 00:01:39
    Last Neighbor-Advertisement sent: 00:01:40
    Last Router-Advertisement sent: 00:01:41
    Next Router-Advertisement sent in: 00:03:34
  Router-Advertisement parameters:
    Periodic interval: 200 to 600 seconds
    Send "Managed Address Configuration" flag: false
    Send "Other Stateful Configuration" flag: false
    Send "Current Hop Limit" field: 64
    Send "MTU" option value: 1500
    Send "Router Lifetime" field: 1800 secs
    Send "Reachable Time" field: 0 ms
    Send "Retrans Timer" field: 0 ms
    Suppress RA: Disabled
    Suppress MTU in RA: Disabled
  Neighbor-Solicitation parameters:
    NS retransmit interval: 1000 ms
  ICMPv6 error message parameters:
    Send redirects: true
    Send unreachable: false
  ICMPv6-nd Statistics (sent/received):
    RAs: 3/0, RSs: 0/0, NAs: 2/0, NSs: 7/0, RDs: 0/0
    Interface statistics last reset: never
switch(config)#
```

This example shows how to configure a MAC-embedded IPv6 address with ND mac-extract (excluding NUD phase) enabled:

```
switch# configure terminal
Enter configuration commands, one per line. End with CNTL/Z.
switch(config)# interface ethernet 1/5
switch(config-if)# no switchport
switch(config-if)# mac-address ipv6-extract
switch(config-if)# ipv6 address 2002:2::10/64
switch(config-if)# ipv6 nd mac-extract exclude nud-phase
```

```

switch(config-if)# show ipv6 icmp interface ethernet 1/5
ICMPv6 Interfaces for VRF "default"
Ethernet1/5, Interface status: protocol-up/link-up/admin-up
IPv6 address: 2002:2::10
IPv6 subnet: 2002:2::/64
IPv6 interface DAD state: VALID
ND mac-extract : Enabled (Excluding NUD Phase)
ICMPv6 active timers:
  Last Neighbor-Solicitation sent: 00:06:45
  Last Neighbor-Advertisement sent: 00:06:46
  Last Router-Advertisement sent: 00:02:18
  Next Router-Advertisement sent in: 00:02:24
Router-Advertisement parameters:
  Periodic interval: 200 to 600 seconds
  Send "Managed Address Configuration" flag: false
  Send "Other Stateful Configuration" flag: false
  Send "Current Hop Limit" field: 64
  Send "MTU" option value: 1500
  Send "Router Lifetime" field: 1800 secs
  Send "Reachable Time" field: 0 ms
  Send "Retrans Timer" field: 0 ms
  Suppress RA: Disabled
  Suppress MTU in RA: Disabled
Neighbor-Solicitation parameters:
  NS retransmit interval: 1000 ms
ICMPv6 error message parameters:
  Send redirects: true
  Send unreachable: false
ICMPv6-nd Statistics (sent/received):
  RAs: 6/0, RSs: 0/0, NAs: 2/0, NSs: 7/0, RDs: 0/0
  Interface statistics last reset: never
switch(config-if)#

```

## Configuring SVI Autostate Disable

You can configure a SVI to remain active even if no interfaces are up in the corresponding VLAN. This enhancement is called Autostate Disable.

### SUMMARY STEPS

1. switch# **configure terminal**
2. switch(config)# **system default interface-vlan autostate**
3. switch(config)# **feature interface-vlan**
4. switch(config)# **interface vlan *vlan id***
5. (config-if)# **[no] autostate**
6. (config-if)# **end**
7. **show running-config interface vlan *vlan id***

### DETAILED STEPS

	Command or Action	Purpose
Step 1	switch# <b>configure terminal</b>	Enters global configuration mode.

	Command or Action	Purpose
<b>Step 2</b>	switch(config)# <b>system default interface-vlan autostate</b>	Reenables the system default autostate behavior on Switching Virtual Interface (SVI) in a VLAN. Use the no form of the command to disable the autostate behavior on SVI.
<b>Step 3</b>	switch(config)# <b>feature interface-vlan</b>	Enables the creation of VLAN interfaces SVI.
<b>Step 4</b>	switch(config)# <b>interface vlan</b> <i>vlan id</i>	Disables the VLAN interface and enters interface configuration mode.
<b>Step 5</b>	(config-if)# <b>[no] autostate</b>	Disables the default autostate behavior of SVIs on the VLAN interface.
<b>Step 6</b>	(config-if)# <b>end</b>	Returns to privileged EXEC mode.
<b>Step 7</b>	<b>show running-config interface vlan</b> <i>vlan id</i>	(Optional) Displays the running configuration for a specific port channel.

### Example

This example shows how to configure the SVI Autostate Disable feature:

```
switch# configure terminal
switch(config)# system default interface-vlan autostate
switch(config)# feature interface-vlan
switch(config)# interface vlan 2
switch(config-if)# no autostate
switch(config-if)# end
```

## Configuring a DHCP Client on an Interface

You can configure the IP address of a DHCP client on an SVI, a management interface, or a physical Ethernet interface.

### SUMMARY STEPS

1. switch# **configure terminal**
2. switch(config)# **interface ethernet** *type slot/port* | **mgmt** *mgmt-interface-number* | **vlan** *vlan id*
3. switch(config-if)# **[no] ip** | **ipv6 address dhcp**
4. (Optional) switch(config)# **copy running-config startup-config**

### DETAILED STEPS

	Command or Action	Purpose
<b>Step 1</b>	switch# <b>configure terminal</b>	Enters global configuration mode.
<b>Step 2</b>	switch(config)# <b>interface ethernet</b> <i>type slot/port</i>   <b>mgmt</b> <i>mgmt-interface-number</i>   <b>vlan</b> <i>vlan id</i>	Creates a physical Ethernet interface, a management interface, or a VLAN interface.  The range of <i>vlan id</i> is from 1 to 4094.

	Command or Action	Purpose
Step 3	switch(config-if)# [no] ip   ipv6 address dhcp	Requests the DHCP server for an IPv4 or IPv6 address. The <b>no</b> form of this command removes any address that was acquired.
Step 4	(Optional) switch(config)# copy running-config startup-config	Saves the change persistently through reboots and restarts by copying the running configuration to the startup configuration.

### Example

This example shows how to configure the IP address of a DHCP client on an SVI:

```
switch# configure terminal
switch(config)# interface vlan 15
switch(config-if)# ip address dhcp
```

This example shows how to configure an IPv6 address of a DHCP client on a management interface:

```
switch# configure terminal
switch(config)# interface mgmt 0
switch(config-if)# ipv6 address dhcp
```

## Verifying the Layer 3 Interfaces Configuration

Use one of the following commands to verify the configuration:

Command	Purpose
<b>show interface ethernet</b> <i>slot/port</i>	Displays the Layer 3 interface configuration, status, and counters (including the 5-minute exponentially decayed moving average of inbound and outbound packet and byte rates).
<b>show interface ethernet</b> <i>slot/port</i> <b>brief</b>	Displays the Layer 3 interface operational status.
<b>show interface ethernet</b> <i>slot/port</i> <b>capabilities</b>	Displays the Layer 3 interface capabilities, including port type, speed, and duplex.
<b>show interface ethernet</b> <i>slot/port</i> <b>description</b>	Displays the Layer 3 interface description.
<b>show interface ethernet</b> <i>slot/port</i> <b>status</b>	Displays the Layer 3 interface administrative status, port mode, speed, and duplex.
<b>show interface ethernet</b> <i>slot/port.number</i>	Displays the subinterface configuration, status, and counters (including the f-minute exponentially decayed moving average of inbound and outbound packet and byte rates).

Command	Purpose
<b>show interface port-channel</b> <i>channel-id.number</i>	Displays the port-channel subinterface configuration, status, and counters (including the 5-minute exponentially decayed moving average of inbound and outbound packet and byte rates).
<b>show interface loopback</b> <i>number</i>	Displays the loopback interface configuration, status, and counters.
<b>show interface loopback</b> <i>number</i> <b>brief</b>	Displays the loopback interface operational status.
<b>show interface loopback</b> <i>number</i> <b>description</b>	Displays the loopback interface description.
<b>show interface loopback</b> <i>number</i> <b>status</b>	Displays the loopback interface administrative status and protocol status.
<b>show interface vlan</b> <i>number</i>	Displays the VLAN interface configuration, status, and counters.
<b>show interface vlan</b> <i>number</i> <b>brief</b>	Displays the VLAN interface operational status.
<b>show interface vlan</b> <i>number</i> <b>description</b>	Displays the VLAN interface description.
<b>show interface vlan</b> <i>number</i> <b>private-vlan mapping</b>	Displays the VLAN interface private VLAN information.
<b>show interface vlan</b> <i>number</i> <b>status</b>	Displays the VLAN interface administrative status and protocol status.

## Triggering the Layer 3 Interface Consistency Checker

You can manually trigger the Layer 3 interface consistency checker to compare the hardware and software configuration of all physical interfaces in a module and display the results. To manually trigger the Layer 3 Interface consistency checker and display the results, use the following command in any mode:

### SUMMARY STEPS

1. **show consistency-checker l3-interface module** *slot*

### DETAILED STEPS

	Command or Action	Purpose
<b>Step 1</b>	<b>show consistency-checker l3-interface module</b> <i>slot</i>	Starts the Layer 3 interface consistency check on all Layer 3 physical interfaces of a module that are up and displays its results.

### Example

This example shows how to trigger the Layer 3 interface consistency check and display its results:



```

switch# show consistency-checker l3-interface module 1
L3 LIF Checks: L3 Vlan, CML Flags, IPv4 Enable
Consistency Check: PASSED
No inconsistencies found for:
  Ethernet1/17
  Ethernet1/49
  Ethernet1/50

```

## Monitoring Layer 3 Interfaces

Use one of the following commands to display statistics about the feature:

Command	Purpose
<b>load-interval</b> <i>seconds</i>   <b>counter</b> { <b>1</b>   <b>2</b>   <b>3</b> } <i>seconds</i>	Sets three different sampling intervals to bit-rate and packet-rate statistics. The range is from 5 seconds to 300 seconds.
<b>show interface ethernet</b> <i>slot/port</i> <b>counters</b>	Displays the Layer 3 interface statistics (unicast, multicast, and broadcast).
<b>show interface ethernet</b> <i>slot/port</i> <b>counters brief</b> <i>load-interval-id</i>	Displays the Layer 3 interface input and output counters.  The load interval ID specifies a single load interval ID to display the input and output rates.  The load interval ID ranges between 1 and 3.
<b>show interface ethernet</b> <i>slot/port</i> <b>counters detailed</b> <b>[all]</b>	Displays the Layer 3 interface statistics. You can optionally include all 32-bit and 64-bit packet and byte counters (including errors).
<b>show interface ethernet</b> <i>slot/port</i> <b>counters error</b>	Displays the Layer 3 interface input and output errors.
<b>show interface ethernet</b> <i>slot/port</i> <b>counters snmp</b>	Displays the Layer 3 interface counters reported by SNMP MIBs. You cannot clear these counters.
<b>show interface ethernet</b> <i>slot/port.number</i> <b>counters</b>	Displays the subinterface statistics (unicast, multicast, and broadcast).
<b>show interface port-channel</b> <i>channel-id.number</i> <b>counters</b>	Displays the port-channel subinterface statistics (unicast, multicast, and broadcast).
<b>show interface loopback</b> <i>number</i> <b>counters</b>	Displays the loopback interface input and output counters (unicast, multicast, and broadcast).
<b>show interface loopback</b> <i>number</i> <b>counters detailed</b> <b>[all]</b>	Displays the loopback interface statistics. You can optionally include all 32-bit and 64-bit packet and byte counters (including errors).
<b>show interface loopback</b> <i>number</i> <b>counters errors</b>	Displays the loopback interface input and output errors.

Command	Purpose
<b>show interface vlan <i>number</i> counters</b>	Displays the VLAN interface input and output counters (unicast, multicast, and broadcast).
<b>show interface vlan <i>number</i> counters detailed [all]</b>	Displays the VLAN interface statistics. You can optionally include all Layer 3 packet and byte counters (unicast and multicast).
<b>show interface vlan <i>counters</i> snmp</b>	Displays the VLAN interface counters reported by SNMP MIBs. You cannot clear these counters.

## Configuration Examples for Layer 3 Interfaces

This example shows how to configure Ethernet subinterfaces:

```
switch# configuration terminal
switch(config)# interface ethernet 2/1.10
switch(config-if)# description Layer 3 for VLAN 10
switch(config-if)# encapsulation dot1q 10
switch(config-if)# ip address 192.0.2.1/8
switch(config-if)# copy running-config startup-config
```

This example shows how to configure a VLAN interface:

```
switch# configuration terminal
switch(config)# interface vlan 100
switch(config-if)# no switchport

switch(config-if)# ipv6 address 33:0DB::2/8
switch(config-if)# copy running-config startup-config
```

This example shows how to configure Switching Virtual Interface (SVI) Autostate Disable:

```
switch# configure terminal
switch(config)# system default interface-vlan autostate
switch(config)# feature interface-vlan
switch(config)# interface vlan 2
switch(config-if)# no autostate
switch(config-if)# end
switch# show running-config interface vlan 2
```

This example shows how to configure a loopback interface:

```
switch# configuration terminal
switch(config)# interface loopback 3
switch(config-if)# no switchport
switch(config-if)# ip address 192.0.2.2/32
switch(config-if)# copy running-config startup-config
```

This example shows how to configure the three sample load intervals for an Ethernet port:

```
switch# configure terminal
switch(config)# interface ethernet 1/3
switch(config-if)# load-interval counter 1 5
switch(config-if)# load-interval counter 2 135
```

```
switch(config-if)# load-interval counter 3 225
switch(config-if)#
```

## Example of Changing VRF Membership for an Interface

- Enable Layer 3 configuration retention when changing VRF membership.

```
switch# configure terminal
switch(config)# system vrf-member-change retain-l3-config
```

Warning: Will retain L3 configuration when vrf member change on interface.

- Verify Layer 3 retention.

```
switch# show running-config | include vrf-member-change

system vrf-member-change retain-l3-config
```

- Configure the SVI interface with Layer 3 configuration as VRF "blue".

```
switch# configure terminal
switch(config)# show running-config interface vlan 2002
```

```
interface Vlan2002
description TESTSVI
no shutdown
mtu 9192
vrf member blue
no ip redirects
ip address 192.168.211.2/27
ipv6 address 2620:10d:c041:12::2/64
ipv6 link-local fe80::1
ip router ospf 1 area 0.0.0.0
ipv6 router ospfv3 1 area 0.0.0.0
hsrp version 2
hsrp 2002
preempt delay minimum 300 reload 600
priority 110 forwarding-threshold lower 1 upper 110
ip 192.168.211.1
hsrp 2002 ipv6
preempt delay minimum 300 reload 600
priority 110 forwarding-threshold lower 1 upper 110
ip 2620:10d:c041:12::1
```

- Change the SVI interface VRF to "red".

```
switch# configure terminal

Enter configuration commands, one per line. End with CNTL/Z.
switch(config)# interface vlan 2002
switch(config-if)# vrf member red
```

Warning: Retain-L3-config is on, deleted and re-added L3 config on interface Vlan2002

- Verify SVI interface after VRF change.

```
switch# configure terminal
switch(config)# show running-config interface vlan 2002
```

```

interface Vlan2002
description TESTSVI
no shutdown
mtu 9192
vrf member red
no ip redirects
ip address 192.168.211.2/27
ipv6 address 2620:10d:c041:12::2/64
ipv6 link-local fe80::1
ip router ospf 1 area 0.0.0.0
ipv6 router ospfv3 1 area 0.0.0.0
hsrp version 2
hsrp 2002
preempt delay minimum 300 reload 600
priority 110 forwarding-threshold lower 1 upper 110
ip 192.168.211.1
hsrp 2002 ipv6
preempt delay minimum 300 reload 600
priority 110 forwarding-threshold lower 1 upper 110
ip 2620:10d:c041:12::1

```

**Note**

- When changing the VRF, the Layer 3 configuration retention affects:
  - Physical Interface
  - Loopback Interface
  - SVI Interface
  - Sub-interface
  - Tunnel Interface
  - Port-Channel
- When changing the VRF, the existing Layer 3 configuration is deleted and reapplied. All routing protocols, such as OSPF/ISIS/EIGRP/HSRP, go down in the old VRF and come up in the new VRF.
- Direct/Local IPv4/IPv6 addresses are removed from the old VRF and installed in the new VRF.
- Some traffic loss might occur during the VRF change.

## Related Documents for Layer 3 Interfaces

Related Topics	Document Title
Command syntax	<i>Cisco Nexus 3000 Series Command Reference</i>
IP	“Configuring IP” chapter in the <i>Cisco Nexus 3000 Series NX-OS Unicast Routing Configuration Guide</i>

Related Topics	Document Title
VLAN	“Configuring VLANs” chapter in the <i>Cisco Nexus 3000 Series NX-OS Layer 2 Switching Configuration Guide</i>

## MIBs for Layer 3 Interfaces

MIB	MIB Link
CISCO-IF-EXTENSION-MIB	To locate and download MIBs, go to the following URL: <a href="http://www.cisco.com/public/sw-center/netmgmt/cmtk/mibs.shtml">http://www.cisco.com/public/sw-center/netmgmt/cmtk/mibs.shtml</a>
ETHERLIKE-MIB	

## Standards for Layer 3 Interfaces

No new or modified standards are supported by this feature, and support for existing standards has not been modified by this feature.

## Feature History for Layer 3 Interfaces

Feature Name	Release	Feature Information
<b>show interface vlan <i>vlan-id</i> counters</b> command	5.0(3)U3(1)	The <b>show interface vlan <i>vlan-id</i> counters</b> command has been enhanced to correctly show input and output packet counts.

