



Configuring 802.1X

This chapter describes how to configure IEEE 802.1X port-based authentication on Cisco NX-OS devices.

This chapter includes the following sections:

- [Finding Feature Information, on page 1](#)
- [Information About 802.1X, on page 1](#)
- [Licensing Requirements for 802.1X, on page 8](#)
- [Prerequisites for 802.1X, on page 8](#)
- [802.1X Guidelines and Limitations, on page 9](#)
- [Default Settings for 802.1X, on page 9](#)
- [Configuring 802.1X, on page 10](#)
- [Verifying the 802.1X Configuration, on page 31](#)
- [Monitoring 802.1X, on page 32](#)
- [Configuration Example for 802.1X, on page 32](#)
- [Additional References for 802.1X, on page 33](#)
- [Feature History for 802.1X, on page 33](#)

Finding Feature Information

Your software release might not support all the features documented in this module. For the latest caveats and feature information, see the Bug Search Tool at <https://tools.cisco.com/bugsearch/> and the release notes for your software release. To find information about the features documented in this module, and to see a list of the releases in which each feature is supported, see the "New and Changed Information" chapter or the Feature History table in this chapter.

Information About 802.1X

802.1X defines a client-server-based access control and authentication protocol that restricts unauthorized clients from connecting to a LAN through publicly accessible ports. The authentication server authenticates each client connected to a Cisco NX-OS device port.

Until the client is authenticated, 802.1X access control allows only Extensible Authentication Protocol over LAN (EAPOL) traffic through the port to which the client is connected. After authentication is successful, normal traffic can pass through the port.

Device Roles

With 802.1X port-based authentication, the devices in the network have specific roles.

Figure 1: 802.1X Device Roles

This figure shows the device roles in 802.1X.

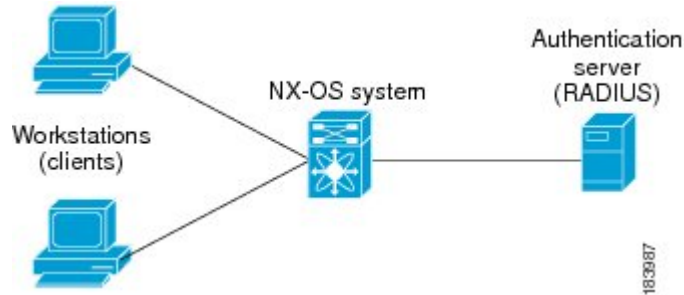

The specific roles are as follows:

Supplicant

The client device that requests access to the LAN and Cisco NX-OS device services and responds to requests from the Cisco NX-OS device. The workstation must be running 802.1X-compliant client software such as that offered in the Microsoft Windows XP operating device.



Note To resolve Windows XP network connectivity and Cisco 802.1X port-based authentication issues, read the Microsoft Knowledge Base article.

Authentication server

The authentication server performs the actual authentication of the supplicant. The authentication server validates the identity of the supplicant and notifies the Cisco NX-OS device regarding whether the supplicant is authorized to access the LAN and Cisco NX-OS device services. Because the Cisco NX-OS device acts as the proxy, the authentication service is transparent to the supplicant. The Remote Authentication Dial-In User Service (RADIUS) security device with Extensible Authentication Protocol (EAP) extensions is the only supported authentication server; it is available in Cisco Secure Access Control Server, version 3.0. RADIUS uses a supplicant-server model in which secure authentication information is exchanged between the RADIUS server and one or more RADIUS clients.

Authenticator

The authenticator controls the physical access to the network based on the authentication status of the supplicant. The authenticator acts as an intermediary (proxy) between the supplicant and the authentication server, requesting identity information from the supplicant, verifying the requested identity information with the authentication server, and relaying a response to the supplicant. The authenticator includes the RADIUS client, which is responsible for encapsulating and decapsulating the EAP frames and interacting with the authentication server.

When the authenticator receives EAPOL frames and relays them to the authentication server, the authenticator strips off the Ethernet header and encapsulates the remaining EAP frame in the RADIUS format. This encapsulation process does not modify or examine the EAP frames, and the authentication server must support EAP within the native frame format. When the authenticator receives frames from the authentication server, the authenticator removes the server's frame header, leaving the EAP frame, which the authenticator then encapsulates for Ethernet and sends to the supplicant.



Note The Cisco NX-OS device can only be an 802.1X authenticator.

Authentication Initiation and Message Exchange

Either the authenticator (Cisco NX-OS device) or the supplicant (client) can initiate authentication. If you enable authentication on a port, the authenticator must initiate authentication when it determines that the port link state transitions from down to up. The authenticator then sends an EAP-request/identity frame to the supplicant to request its identity (typically, the authenticator sends an initial identity/request frame followed by one or more requests for authentication information). When the supplicant receives the frame, it responds with an EAP-response/identity frame.

If the supplicant does not receive an EAP-request/identity frame from the authenticator during bootup, the supplicant can initiate authentication by sending an EAPOL-start frame, which prompts the authenticator to request the supplicant's identity.



Note If 802.1X is not enabled or supported on the network access device, the Cisco NX-OS device drops any EAPOL frames from the supplicant. If the supplicant does not receive an EAP-request/identity frame after three attempts to start authentication, the supplicant transmits data as if the port is in the authorized state. A port in the authorized state means that the supplicant has been successfully authenticated.

When the supplicant supplies its identity, the authenticator begins its role as the intermediary, passing EAP frames between the supplicant and the authentication server until authentication succeeds or fails. If the authentication succeeds, the authenticator port becomes authorized.

The specific exchange of EAP frames depends on the authentication method being used.

Figure 2: Message Exchange

This figure shows a message exchange initiated by the supplicant using the One-Time-Password (OTP) authentication method with a RADIUS server. The OTP authentication device uses a secret pass-phrase to

generate a sequence of one-time (single use)

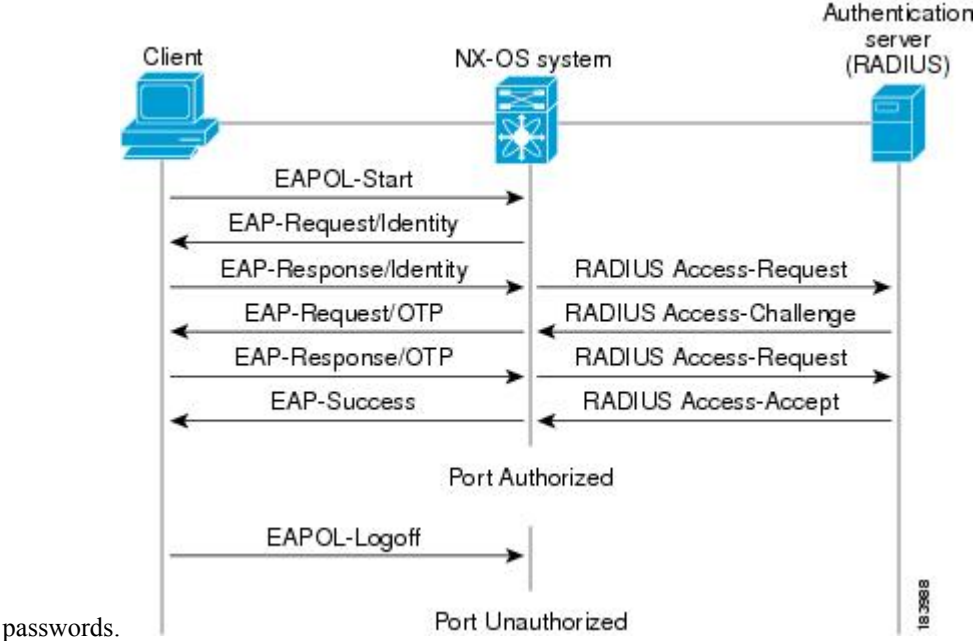

passwords.

The user’s secret pass-phrase never crosses the network at any time such as during authentication or during pass-phrase changes.

Related Topics

[Ports in Authorized and Unauthorized States](#), on page 4

Authenticator PAE Status for Interfaces

When you enable 802.1X on an interface, the Cisco NX-OS software creates an authenticator port access entity (PAE) instance. An authenticator PAE is a protocol entity that supports authentication on the interface. When you disable 802.1X on the interface, the Cisco NX-OS software does not automatically clear the authenticator PAE instances. You can explicitly remove the authenticator PAE from the interface and then reapply it, as needed.

Ports in Authorized and Unauthorized States

The authenticator port state determines if the supplicant is granted access to the network. The port starts in the unauthorized state. In this state, the port disallows all ingress and egress traffic except for 802.1X protocol packets. When a supplicant is successfully authenticated, the port transitions to the authorized state, allowing all traffic for the supplicant to flow normally.

If a client that does not support 802.1X is connected to an unauthorized 802.1X port, the authenticator requests the client’s identity. In this situation, the client does not respond to the request, the port remains in the unauthorized state, and the client is not granted access to the network.

In contrast, when an 802.1X-enabled client connects to a port that is not running the 802.1X protocol, the client initiates the authentication process by sending the EAPOL-start frame. When no response is received, the client sends the request for a fixed number of times. Because no response is received, the client begins sending frames as if the port is in the authorized state.

Ports can have the following authorization states:

Force authorized

Disables 802.1X port-based authentication and transitions to the authorized state without requiring any authentication exchange. The port transmits and receives normal traffic without 802.1X-based authentication of the client. This authorization state is the default.

Force unauthorized

Causes the port to remain in the unauthorized state, ignoring all attempts by the client to authenticate. The authenticator cannot provide authentication services to the client through the interface.

Auto

Enables 802.1X port-based authentication and causes the port to begin in the unauthorized state, allowing only EAPOL frames to be sent and received through the port. The authentication process begins when the link state of the port transitions from down to up or when an EAPOL-start frame is received from the supplicant. The authenticator requests the identity of the client and begins relaying authentication messages between the client and the authentication server. Each supplicant that attempts to access the network is uniquely identified by the authenticator by using the supplicant's MAC address.

If the supplicant is successfully authenticated (receives an Accept frame from the authentication server), the port state changes to authorized, and all frames from the authenticated supplicant are allowed through the port. If the authentication fails, the port remains in the unauthorized state, but authentication can be retried. If the authentication server cannot be reached, the authenticator can retransmit the request. If no response is received from the server after the specified number of attempts, authentication fails, and the supplicant is not granted network access.

When a supplicant logs off, it sends an EAPOL-logoff message, which causes the authenticator port to transition to the unauthorized state.

If the link state of a port transitions from up to down, or if an EAPOL-logoff frame is received, the port returns to the unauthorized state.

MAC Authentication Bypass

You can configure the Cisco NX-OS device to authorize a supplicant based on the supplicant MAC address by using the MAC authentication bypass feature. For example, you can enable this feature on interfaces configured for 802.1X that are connected to devices such as printers.

If 802.1X authentication times out while waiting for an EAPOL response from the supplicant, the Cisco NX-OS device tries to authorize the client by using MAC authentication bypass.

When you enable the MAC authentication bypass feature on an interface, the Cisco NX-OS device uses the MAC address as the supplicant identity. The authentication server has a database of supplicant MAC addresses that are allowed network access. After detecting a client on the interface, the Cisco NX-OS device waits for an Ethernet packet from the client. The Cisco NX-OS device sends the authentication server a RADIUS-access/request frame with a username and password based on the MAC address. If authorization succeeds, the Cisco NX-OS device grants the client access to the network. If authorization fails, the Cisco NX-OS device assigns the port to the guest VLAN if one is configured.

If an EAPOL packet is detected on the interface during the lifetime of the link, the Cisco NX-OS device determines that the device connected to that interface is an 802.1X-capable supplicant and uses 802.1X authentication (not MAC authentication bypass) to authorize the interface. EAPOL history is cleared if the interface link status goes down.

If the Cisco NX-OS device already authorized an interface by using MAC authentication bypass and detects an 802.1X supplicant, the Cisco NX-OS device does not unauthorize the client connected to the interface. When reauthentication occurs, the Cisco NX-OS device uses 802.1X authentication as the preferred

reauthentication process if the previous session ended because the Termination-Action RADIUS attribute value is DEFAULT.

Clients that were authorized with MAC authentication bypass can be reauthenticated. The reauthentication process is the same as that for clients that were authenticated with 802.1X. During reauthentication, the port remains in the previously assigned VLAN. If reauthentication is successful, the switch keeps the port in the same VLAN. If reauthentication fails, the switch assigns the port to the guest VLAN, if one is configured.

If reauthentication is based on the Session-Timeout RADIUS attribute (Attribute[27]) and the Termination-Action RADIUS attribute (Attribute [29]) and if the Termination-Action RADIUS attribute (Attribute [29]) action is Initialize (the attribute value is DEFAULT), the MAC authentication bypass session ends, and connectivity is lost during reauthentication. If MAC authentication bypass is enabled and the 802.1X authentication times out, the switch uses the MAC authentication bypass feature to initiate reauthorization. For more information about these AV pairs, see RFC 3580, *IEEE 802.1X Remote Authentication Dial In User Service (RADIUS) Usage Guidelines*.

MAC authentication bypass interacts with the following features:

- 802.1X authentication—You can enable MAC authentication bypass only if 802.1X authentication is enabled on the port.
- Port security— You can configure 802.1X authentication and port security on the same Layer 2 ports.
- Network admission control (NAC) Layer 2 IP validation—This feature takes effect after an 802.1X port is authenticated with MAC authentication bypass, including hosts in the exception list.

Related Topics

[802.1X and Port Security](#), on page 6

802.1X and Port Security

You can configure port security and 802.1X on the same interfaces. Port security secures the MAC addresses that 802.1X authenticates. 802.1X processes packets before port security processes them, so when you enable both on an interface, 802.1X is already preventing inbound traffic on the interface from unknown MAC addresses.

When you enable 802.1X and port security on the same interface, port security continues to learn MAC addresses by the sticky or dynamic method, as configured. Additionally, depending on whether you enable 802.1X in single-host mode or multiple-host mode, one of the following occurs:

Single host mode

Port security learns the MAC address of the authenticated host.

Multiple host mode

Port security drops any MAC addresses learned for this interface by the dynamic method and learns the MAC address of the first host authenticated by 802.1X.

If a MAC address that 802.1X passes to port security would violate the applicable maximum number of secure MAC addresses, the device sends an authentication failure message to the host.

The device treats MAC addresses authenticated by 802.1X as though they were learned by the dynamic method, even if port security previously learned the address by the sticky or static methods. If you attempt to delete a secure MAC address that has been authenticated by 802.1X, the address remains secure.

If the MAC address of an authenticated host is secured by the sticky or static method, the device treats the address as if it were learned by the dynamic method, and you cannot delete the MAC address manually.

Port security integrates with 802.1X to reauthenticate hosts when the authenticated and secure MAC address of the host reaches its port security age limit. The device behaves differently depending upon the type of aging, as follows:

Absolute

Port security notifies 802.1X and the device attempts to reauthenticate the host. The result of reauthentication determines whether the address remains secure. If reauthentication succeeds, the device restarts the aging timer on the secure address; otherwise, the device drops the address from the list of secure addressees for the interface.

Inactivity

Port security drops the secure address from the list of secure addresses for the interface and notifies 802.1X. The device attempts to reauthenticate the host. If reauthentication succeeds, port security secures the address again.

Single Host and Multiple Hosts Support

The 802.1X feature can restrict traffic on a port to only one endpoint device (single-host mode) or allow traffic from multiple endpoint devices on a port (multi-host mode).

Single-host mode allows traffic from only one endpoint device on the 802.1X port. Once the endpoint device is authenticated, the Cisco NX-OS device puts the port in the authorized state. When the endpoint device leaves the port, the Cisco NX-OS device put the port back into the unauthorized state. A security violation in 802.1X is defined as a detection of frames sourced from any MAC address other than the single MAC address authorized as a result of successful authentication. In this case, the interface on which this security association violation is detected (EAPOL frame from the other MAC address) will be disabled. Single host mode is applicable only for host-to-switch topology and when a single host is connected to the Layer 2 (Ethernet access port) or Layer 3 port (routed port) of the Cisco NX-OS device.

Only the first host has to be authenticated on the 802.1X port configured with multiple host mode. The port is moved to the authorized state after the successful authorization of the first host. Subsequent hosts are not required to be authorized to gain network access once the port is in the authorized state. If the port becomes unauthorized when reauthentication fails or an EAPOL logoff message is received, all attached hosts are denied access to the network. The capability of the interface to shut down upon security association violation is disabled in multiple host mode. This mode is applicable for both switch-to-switch and host-to-switch topologies.

Supported Topologies

The 802.1X port-based authentication is supported in two topologies:

- Point-to-point
- Wireless LAN

In a point-to-point configuration, only one supplicant (client) can connect to the 802.1X-enabled authenticator (Cisco NX-OS device) port. The authenticator detects the supplicant when the port link state changes to the up state. If a supplicant leaves or is replaced with another supplicant, the authenticator changes the port link state to down, and the port returns to the unauthorized state.

Figure 3: Wireless LAN Example

This figure shows 802.1X port-based authentication in a wireless LAN. The 802.1X port is configured as a multiple-host port that becomes authorized as soon as one supplicant is authenticated.

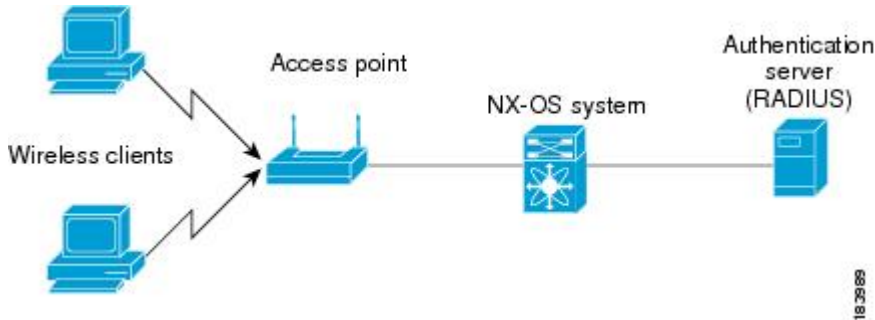

When the port is authorized, all other hosts indirectly attached to the port are granted access to the network. If the port becomes unauthorized (reauthentication fails or an EAPOL-logoff message is received), the Cisco NX-OS device denies access to the network to all of the attached supplicants.

Virtualization Support for 802.1X

The 802.1X configuration and operation are local to the virtual device context (VDC). For more information on VDCs, see the *Cisco Nexus 7000 Series NX-OS Virtual Device Context Configuration Guide*.

Licensing Requirements for 802.1X

The following table shows the licensing requirements for this feature:

Product	License Requirement
Cisco NX-OS	802.1X requires no license. Any feature not included in a license package is bundled with the Cisco NX-OS system images and is provided at no extra charge to you. For an explanation of the Cisco NX-OS licensing scheme, see the <i>Cisco NX-OS Licensing Guide</i> .

Prerequisites for 802.1X

802.1X has the following prerequisites:

- One or more RADIUS servers are accessible in the network.
- 802.1X supplicants are attached to the ports, unless you enable MAC address authentication bypass.

Related Topics

[Enabling MAC Authentication Bypass](#), on page 22

802.1X Guidelines and Limitations

802.1X port-based authentication has the following configuration guidelines and limitations:

- The Cisco NX-OS software supports 802.1X authentication only on physical ports.
- The Cisco NX-OS software does not support 802.1X authentication on port channels or subinterfaces.
- When you enable 802.1X authentication, supplicants are authenticated before any other Layer 2 or Layer 3 features are enabled on an Ethernet interface.
- The Cisco NX-OS software supports 802.1X authentication only on Ethernet interfaces that are in a port channel, a trunk, or an access port.
- The Cisco NX-OS software does not support single host mode on trunk interfaces or member interfaces in a port channel.
- The Cisco NX-OS software does not support MAC address authentication bypass on trunk interfaces.
- The Cisco NX-OS software does not support MAC address authentication bypass on a port channel.
- The Cisco NX-OS software does not support Dot1X on vPC ports and MCT.
- The Cisco NX-OS software does not support the following 802.1X protocol enhancements:
 - One-to-many logical VLAN name to ID mapping
 - Web authorization
 - Dynamic domain bridge assignment
 - IP telephony
- The Cisco NX-OS software does not support dynamic VLAN assignment on the Cisco Nexus 7000 series switches.

Default Settings for 802.1X

This table lists the default settings for 802.1X parameters.

Table 1: Default 802.1X Parameters

Parameters	Default
802.1X feature	Disabled
AAA 802.1X authentication method	Not configured
Per-interface 802.1X protocol enable state	Disabled (force-authorized) Note The port transmits and receives normal traffic without 802.1X-based authentication of the supplicant.
Periodic reauthentication	Disabled

Parameters	Default
Number of seconds between reauthentication attempts	3600 seconds
Quiet timeout period	60 seconds (number of seconds that the Cisco NX-OS device remains in the quiet state following a failed authentication exchange with the supplicant)
Retransmission timeout period	30 seconds (number of seconds that the Cisco NX-OS device should wait for a response to an EAP request/identity frame from the supplicant before retransmitting the request)
Maximum retransmission number	2 times (number of times that the Cisco NX-OS device will send an EAP-request/identity frame before restarting the authentication process)
Host mode	Single host
Supplicant timeout period	30 seconds (when relaying a request from the authentication server to the supplicant, the amount of time that the Cisco NX-OS device waits for a response before retransmitting the request to the supplicant)
Authentication server timeout period	30 seconds (when relaying a response from the supplicant to the authentication server, the amount of time that the Cisco NX-OS device waits for a reply before retransmitting the response to the server)

Configuring 802.1X

This section describes how to configure the 802.1X feature.



Note If you are familiar with the Cisco IOS CLI, be aware that the Cisco NX-OS commands for this feature might differ from the Cisco IOS commands that you would use.

Process for Configuring 802.1X

This section describes the process for configuring 802.1X.

SUMMARY STEPS

1. Enable the 802.1X feature.
2. Configure the connection to the remote RADIUS server.
3. Enable 802.1X feature on the Ethernet interfaces.

DETAILED STEPS

Procedure

-
- Step 1** Enable the 802.1X feature.
- Step 2** Configure the connection to the remote RADIUS server.
- Step 3** Enable 802.1X feature on the Ethernet interfaces.
-

Related Topics

- [Enabling the 802.1X Feature](#), on page 11
- [Configuring AAA Authentication Methods for 802.1X](#), on page 12
- [Controlling 802.1X Authentication on an Interface](#), on page 13

Enabling the 802.1X Feature

You must enable the 802.1X feature on the Cisco NX-OS device before authenticating any supplicant devices.

SUMMARY STEPS

1. **configure terminal**
2. **feature dot1x**
3. **exit**
4. (Optional) **show dot1x**
5. (Optional) **copy running-config startup-config**

DETAILED STEPS

Procedure

	Command or Action	Purpose
Step 1	configure terminal Example: <pre>switch# configure terminal switch(config)#</pre>	Enters global configuration mode.
Step 2	feature dot1x Example: <pre>switch(config)# feature dot1x</pre>	Enables the 802.1X feature. The default is disabled.
Step 3	exit Example: <pre>switch(config)# exit switch#</pre>	Exits configuration mode.

	Command or Action	Purpose
Step 4	(Optional) <code>show dot1x</code> Example: <code>switch# show dot1x</code>	Displays the 802.1X feature status.
Step 5	(Optional) <code>copy running-config startup-config</code> Example: <code>switch# copy running-config startup-config</code>	Copies the running configuration to the startup configuration.

Configuring AAA Authentication Methods for 802.1X

You can use remote RADIUS servers for 802.1X authentication. You must configure RADIUS servers and RADIUS server groups and specify the default AAA authentication method before the Cisco NX-OS device can perform 802.1X authentication.

Before you begin

Obtain the names or addresses for the remote RADIUS server groups.

SUMMARY STEPS

1. `configure terminal`
2. `aaa authentication dot1x default group group-list`
3. `exit`
4. (Optional) `show radius-server`
5. (Optional) `show radius-server group [group-name]`
6. (Optional) `copy running-config startup-config`

DETAILED STEPS

Procedure

	Command or Action	Purpose
Step 1	<code>configure terminal</code> Example: <code>switch# configure terminal</code> <code>switch(config)#</code>	Enters global configuration mode.
Step 2	<code>aaa authentication dot1x default group group-list</code> Example: <code>switch(config)# aaa authentication dot1x default group rad2</code>	Specifies the RADIUS server groups to use for 802.1X authentication. The <i>group-list</i> argument consists of a space-delimited list of group names. The group names are the following: <ul style="list-style-type: none"> • radius—Uses the global pool of RADIUS servers for authentication.

	Command or Action	Purpose
		<ul style="list-style-type: none"> <i>named-group</i> —Uses the global pool of RADIUS servers for authentication.
Step 3	exit Example: <pre>switch(config)# exit switch#</pre>	Exits configuration mode.
Step 4	(Optional) show radius-server Example: <pre>switch# show radius-server</pre>	Displays the RADIUS server configuration.
Step 5	(Optional) show radius-server group [group-name] Example: <pre>switch# show radius-server group rad2</pre>	Displays the RADIUS server group configuration.
Step 6	(Optional) copy running-config startup-config Example: <pre>switch# copy running-config startup-config</pre>	Copies the running configuration to the startup configuration.

Related Topics[Configuring AAA](#)[Configuring RADIUS](#)

Controlling 802.1X Authentication on an Interface

You can control the 802.1X authentication performed on an interface. An interface can have the following 802.1X authentication states:

Auto

Enables 802.1X authentication on the interface.

Force-authorized

Disables 802.1X authentication on the interface and allows all traffic on the interface without authentication. This state is the default.

Force-unauthorized

Disallows all traffic on the interface.

Before you begin

Enable the 802.1X feature on the Cisco NX-OS device.

SUMMARY STEPS

1. **configure terminal**
2. **interface ethernet slot / port**
3. **dot1x port-control {auto | force-authorized | forced-unauthorized}**
4. **exit**

5. (Optional) **show dot1x all**
6. (Optional) **show dot1x interface ethernet *slot / port***
7. (Optional) **copy running-config startup-config**

DETAILED STEPS

Procedure

	Command or Action	Purpose
Step 1	configure terminal Example: switch# configure terminal switch(config)#	Enters global configuration mode.
Step 2	interface ethernet <i>slot / port</i> Example: switch(config)# interface ethernet 2/1 switch(config-if)#	Selects the interface to configure and enters interface configuration mode.
Step 3	dot1x port-control {auto force-authorized forced-unauthorized} Example: switch(config-if)# dot1x port-control auto	Changes the 802.1X authentication state on the interface. The default is force-authorized.
Step 4	exit Example: switch(config)# exit switch#	Exits configuration mode.
Step 5	(Optional) show dot1x all Example: switch# show dot1x all	Displays all 802.1X feature status and configuration information.
Step 6	(Optional) show dot1x interface ethernet <i>slot / port</i> Example: switch# show dot1x interface ethernet 2/1	Displays 802.1X feature status and configuration information for an interface.
Step 7	(Optional) copy running-config startup-config Example: switch# copy running-config startup-config	Copies the running configuration to the startup configuration.

Related Topics

[Enabling the 802.1X Feature](#), on page 11

Creating or Removing an Authenticator PAE on an Interface

You can create or remove the 802.1X authenticator port access entity (PAE) instance on an interface.



Note By default, the Cisco NX-OS software creates the authenticator PAE instance on the interface when you enable 802.1X on an interface.

Before you begin

Enable the 802.1X feature.

SUMMARY STEPS

1. **configure terminal**
2. (Optional) **show dot1x interface ethernet slot/port**
3. **interface ethernet slot/port**
4. **[no] dot1x pae authenticator**
5. (Optional) **copy running-config startup-config**

DETAILED STEPS

Procedure

	Command or Action	Purpose
Step 1	configure terminal Example: <pre>switch# configure terminal switch(config)#</pre>	Enters global configuration mode.
Step 2	(Optional) show dot1x interface ethernet slot/port Example: <pre>switch# show dot1x interface ethernet 2/1</pre>	Displays the 802.1X configuration on the interface.
Step 3	interface ethernet slot/port Example: <pre>switch(config)# interface ethernet 2/1 switch(config-if)#</pre>	Selects the interface to configure and enters interface configuration mode.
Step 4	[no] dot1x pae authenticator Example: <pre>switch(config-if)# dot1x pae authenticator</pre>	Creates an authenticator PAE instance on the interface. Use the no form to remove the PAE instance from the interface. Note If an authenticator PAE already exists on the interface the dot1x pae authentication command does not change the configuration on the interface.

	Command or Action	Purpose
Step 5	(Optional) copy running-config startup-config Example: switch(config)# copy running-config startup-config	Copies the running configuration to the startup configuration.

Enabling Periodic Reauthentication for an Interface

You can enable periodic 802.1X reauthentication on an interface and specify how often it occurs. If you do not specify a time period before enabling reauthentication, the number of seconds between reauthentication defaults to the global value.



Note During the reauthentication process, the status of an already authenticated supplicant is not disrupted.

Before you begin

Enable the 802.1X feature on the Cisco NX-OS device.

SUMMARY STEPS

1. **configure terminal**
2. **interface ethernet *slot/port***
3. **dot1x re-authentication**
4. (Optional) **dot1x timeout re-authperiod *seconds***
5. **exit**
6. (Optional) **show dot1x all**
7. (Optional) **copy running-config startup-config**

DETAILED STEPS

Procedure

	Command or Action	Purpose
Step 1	configure terminal Example: switch# configure terminal switch(config)#	Enters global configuration mode.
Step 2	interface ethernet <i>slot/port</i> Example: switch(config)# interface ethernet 2/1 switch(config-if)#	Selects the interface to configure and enters interface configuration mode.

	Command or Action	Purpose
Step 3	dot1x re-authentication Example: switch(config-if)# dot1x re-authentication	Enables periodic reauthentication of the supplicants connected to the interface. By default, periodic authentication is disabled.
Step 4	(Optional) dot1x timeout re-authperiod seconds Example: switch(config-if)# dot1x timeout re-authperiod 3300	Sets the number of seconds between reauthentication attempts. The default is 3600 seconds. The range is from 1 to 65535. Note This command affects the behavior of the Cisco NX-OS device only if you enable periodic reauthentication on the interface.
Step 5	exit Example: switch(config-if)# exit switch(config)#	Exits configuration mode.
Step 6	(Optional) show dot1x all Example: switch(config)# show dot1x all	Displays all 802.1X feature status and configuration information.
Step 7	(Optional) copy running-config startup-config Example: switch(config)# copy running-config startup-config	Copies the running configuration to the startup configuration.

Related Topics

[Enabling the 802.1X Feature](#), on page 11

[Manually Reauthenticating Supplicants](#), on page 17

Manually Reauthenticating Supplicants

You can manually reauthenticate the supplicants for the entire Cisco NX-OS device or for an interface.



Note During the reauthentication process, the status of an already authenticated supplicant is not disrupted.

Before you begin

Enable the 802.1X feature on the Cisco NX-OS device.

SUMMARY STEPS

1. **dot1x re-authenticate** [interface *slot/port*]

DETAILED STEPS**Procedure**

	Command or Action	Purpose
Step 1	dot1x re-authenticate [interface <i>slot/port</i>] Example: switch# dot1x re-authenticate interface 2/1	Reauthenticates the supplicants on the Cisco NX-OS device or on an interface.

Related Topics

[Enabling the 802.1X Feature](#), on page 11

[Enabling Periodic Reauthentication for an Interface](#), on page 16

Manually Initializing 802.1X Authentication

You can manually initialize the authentication for all supplicants on a Cisco NX-OS device or for a specific interface.



Note Initializing the authentication clears any existing authentication status before starting the authentication process for the client.

Before you begin

Enable the 802.1X feature on the Cisco NX-OS device.

SUMMARY STEPS

1. **dot1x initialize** [**interface ethernet** *slot/port*]

DETAILED STEPS**Procedure**

	Command or Action	Purpose
Step 1	dot1x initialize [interface ethernet <i>slot/port</i>] Example: switch# dot1x initialize interface ethernet 2/1	Initializes 802.1X authentication on the Cisco NX-OS device or on a specified interface.

Changing 802.1X Authentication Timers for an Interface

You can change the following 802.1X authentication timers on the Cisco NX-OS device interfaces:

Quiet-period timer

When the Cisco NX-OS device cannot authenticate the supplicant, the switch remains idle for a set period of time and then tries again. The quiet-period timer value determines the idle period. An authentication failure might occur because the supplicant provided an invalid password. You can provide a faster response time to the user by entering a smaller number than the default. The default is the value of the global quiet period timer. The range is from 1 to 65535 seconds.

Rate-limit timer

The rate-limit period throttles EAPOL-Start packets from supplicants that are sending too many EAPOL-Start packets. The authenticator ignores EAPOL-Start packets from supplicants that have successfully authenticated for the rate-limit period duration. The default value is 0 seconds and the authenticator processes all EAPOL-Start packets. The range is from 1 to 65535 seconds.

Switch-to-authentication-server retransmission timer for Layer 4 packets

The authentication server notifies the switch each time that it receives a Layer 4 packet. If the switch does not receive a notification after sending a packet, the Cisco NX-OS device waits a set period of time and then retransmits the packet. The default is 30 seconds. The range is from 1 to 65535 seconds.

Switch-to-supplicant retransmission timer for EAP response frames

The supplicant responds to the EAP-request/identity frame from the Cisco NX-OS device with an EAP-response/identity frame. If the Cisco NX-OS device does not receive this response, it waits a set period of time (known as the retransmission time) and then retransmits the frame. The default is 30 seconds. The range is from 1 to 65535 seconds.

Switch-to-supplicant retransmission timer for EAP request frames

The supplicant notifies the Cisco NX-OS device it that received the EAP request frame. If the authenticator does not receive this notification, it waits a set period of time and then retransmits the frame. The default is the value of the global retransmission period timer. The range is from 1 to 65535 seconds.



Note You should change the default values only to adjust for unusual circumstances such as unreliable links or specific behavioral problems with certain supplicants and authentication servers.

Before you begin

Enable the 802.1X feature on the Cisco NX-OS device.

SUMMARY STEPS

1. **configure terminal**
2. **interface ethernet *slot/port***
3. (Optional) **dot1x timeout quiet-period *seconds***
4. (Optional) **dot1x timeout ratelimit-period *seconds***
5. (Optional) **dot1x timeout server-timeout *seconds***
6. (Optional) **dot1x timeout supp-timeout *seconds***
7. (Optional) **dot1x timeout tx-period *seconds***
8. **exit**
9. (Optional) **show dot1x all**
10. (Optional) **copy running-config startup-config**

DETAILED STEPS

Procedure

	Command or Action	Purpose
Step 1	configure terminal Example: switch# configure terminal switch(config)#	Enters global configuration mode.
Step 2	interface ethernet slot/port Example: switch(config)# interface ethernet 2/1 switch(config-if)	Selects the interface to configure and enters interface configuration mode.
Step 3	(Optional) dot1x timeout quiet-period seconds Example: switch(config-if)# dot1x timeout quiet-period 25	Sets the number of seconds that the authenticator waits for a response to an EAP-request/identity frame from the supplicant before retransmitting the request. The default is the global number of seconds set for all interfaces. The range is from 1 to 65535 seconds.
Step 4	(Optional) dot1x timeout ratelimit-period seconds Example: switch(config-if)# dot1x timeout ratelimit-period 10	Sets the number of seconds that the authenticator ignores EAPOL-Start packets from supplicants that have successfully authenticated. The default value is 0 seconds. The range is from 1 to 65535 seconds.
Step 5	(Optional) dot1x timeout server-timeout seconds Example: switch(config-if)# dot1x timeout server-timeout 60	Sets the number of seconds that the Cisco NX-OS device waits before retransmitting a packet to the authentication server. The default is 30 seconds. The range is from 1 to 65535 seconds.
Step 6	(Optional) dot1x timeout supp-timeout seconds Example: switch(config-if)# dot1x timeout supp-timeout 20	Sets the number of seconds that the Cisco NX-OS device waits for the supplicant to respond to an EAP request frame before the Cisco NX-OS device retransmits the frame. The default is 30 seconds. The range is from 1 to 65535 seconds.
Step 7	(Optional) dot1x timeout tx-period seconds Example: switch(config-if)# dot1x timeout tx-period 40	Sets the number of seconds between the retransmission of EAP request frames when the supplicant does not send notification that it received the request. The default is the global number of seconds set for all interfaces. The range is from 1 to 65535 seconds.
Step 8	exit Example: switch(config)# exit switch#	Exits configuration mode.

	Command or Action	Purpose
Step 9	(Optional) show dot1x all Example: switch# show dot1x all	Displays the 802.1X configuration.
Step 10	(Optional) copy running-config startup-config Example: switch# copy running-config startup-config	Copies the running configuration to the startup configuration.

Related Topics

[Enabling the 802.1X Feature](#), on page 11

Enabling Single Host or Multiple Hosts Mode

You can enable single host or multiple hosts mode on an interface.

Before you begin

Enable the 802.1X feature on the Cisco NX-OS device.

SUMMARY STEPS

1. **configure terminal**
2. **interface ethernet *slot/port***
3. **dot1x host-mode {multi-host | single-host}**
4. **exit**
5. (Optional) **show dot1x all**
6. (Optional) **copy running-config startup-config**

DETAILED STEPS**Procedure**

	Command or Action	Purpose
Step 1	configure terminal Example: switch# configure terminal switch(config)#	Enters global configuration mode.
Step 2	interface ethernet <i>slot/port</i> Example: switch(config)# interface ethernet 2/1 switch(config-if)	Selects the interface to configure and enters interface configuration mode.
Step 3	dot1x host-mode {multi-host single-host} Example:	Configures the host mode. The default is single-host.

	Command or Action	Purpose
	<code>switch(config-if)# dot1x host-mode multi-host</code>	Note Make sure that the dot1x port-control interface configuration command is set to auto for the specified interface.
Step 4	exit Example: <code>switch(config-if)# exit</code> <code>switch(config)#</code>	Exits configuration mode.
Step 5	(Optional) show dot1x all Example: <code>switch# show dot1x all</code>	Displays all 802.1X feature status and configuration information.
Step 6	(Optional) copy running-config startup-config Example: <code>switch(config)# copy running-config startup-config</code>	Copies the running configuration to the startup configuration.

Related Topics

[Enabling the 802.1X Feature](#), on page 11

Enabling MAC Authentication Bypass

You can enable MAC authentication bypass on an interface that has no supplicant connected.

Before you begin

Enable the 802.1X feature on the Cisco NX-OS device.

SUMMARY STEPS

1. **configure terminal**
2. **interface ethernet *slot/port***
3. **dot1x mac-auth-bypass [eap]**
4. **exit**
5. (Optional) **show dot1x all**
6. (Optional) **copy running-config startup-config**

DETAILED STEPS

Procedure

	Command or Action	Purpose
Step 1	configure terminal Example:	Enters global configuration mode.

	Command or Action	Purpose
	<code>switch# configure terminal</code> <code>switch(config)#</code>	
Step 2	interface ethernet slot/port Example: <code>switch(config)# interface ethernet 2/1</code> <code>switch(config-if)</code>	Selects the interface to configure and enters interface configuration mode.
Step 3	dot1x mac-auth-bypass [eap] Example: <code>switch(config-if)# dot1x mac-auth-bypass</code>	Enables MAC authentication bypass. The default is bypass disabled. Use the eap keyword to configure the Cisco NX-OS device to use EAP for authorization.
Step 4	exit Example: <code>switch(config-if)# exit</code> <code>switch(config)#</code>	Exits configuration mode.
Step 5	(Optional) show dot1x all Example: <code>switch# show dot1x all</code>	Displays all 802.1X feature status and configuration information.
Step 6	(Optional) copy running-config startup-config Example: <code>switch(config)# copy running-config startup-config</code>	Copies the running configuration to the startup configuration.

Related Topics

[Enabling the 802.1X Feature](#), on page 11

Disabling 802.1X Authentication on the Cisco NX-OS Device

You can disable 802.1X authentication on the Cisco NX-OS device. By default, the Cisco NX-OS software enables 802.1X authentication after you enable the 802.1X feature. However, when you disable the 802.1X feature, the configuration is removed from the Cisco NX-OS device. The Cisco NX-OS software allows you to disable 802.1X authentication without losing the 802.1X configuration.



Note When you disable 802.1X authentication, the port mode for all interfaces defaults to force-authorized regardless of the configured port mode. When you reenables 802.1X authentication, the Cisco NX-OS software restores the configured port mode on the interfaces.

Before you begin

Enable the 802.1X feature on the Cisco NX-OS device.

SUMMARY STEPS

1. **configure terminal**
2. **no dot1x system-auth-control**
3. **exit**
4. (Optional) **show dot1x**
5. (Optional) **copy running-config startup-config**

DETAILED STEPS**Procedure**

	Command or Action	Purpose
Step 1	configure terminal Example: <pre>switch# configure terminal switch(config)#</pre>	Enters global configuration mode.
Step 2	no dot1x system-auth-control Example: <pre>switch(config)# no dot1x system-auth-control</pre>	Disables 802.1X authentication on the Cisco NX-OS device. The default is enabled. Note Use the dot1x system-auth-control command to enable 802.1X authentication on the Cisco NX-OS device.
Step 3	exit Example: <pre>switch(config)# exit switch#</pre>	Exits configuration mode.
Step 4	(Optional) show dot1x Example: <pre>switch# show dot1x</pre>	Displays the 802.1X feature status.
Step 5	(Optional) copy running-config startup-config Example: <pre>switch# copy running-config startup-config</pre>	Copies the running configuration to the startup configuration.

Related Topics

[Enabling the 802.1X Feature](#), on page 11

[Controlling 802.1X Authentication on an Interface](#), on page 13

Disabling the 802.1X Feature

You can disable the 802.1X feature on the Cisco NX-OS device.

When you disable 802.1X, all related configurations are automatically discarded. The Cisco NX-OS software creates an automatic checkpoint that you can use if you reenables 802.1X and want to recover the configuration. For more information, see the *Cisco NX-OS System Management Configuration Guide* for your platform.

Before you begin

Enable the 802.1X feature on the Cisco NX-OS device.

SUMMARY STEPS

1. **configure terminal**
2. **no feature dot1x**
3. **exit**
4. (Optional) **copy running-config startup-config**

DETAILED STEPS

Procedure

	Command or Action	Purpose
Step 1	configure terminal Example: <pre>switch# configure terminal switch(config)#</pre>	Enters global configuration mode.
Step 2	no feature dot1x Example: <pre>switch(config)# no feature dot1x</pre>	Disables 802.1X. Caution Disabling the 802.1X feature removes all 802.1X configuration.
Step 3	exit Example: <pre>switch(config)# exit switch#</pre>	Exits configuration mode.
Step 4	(Optional) copy running-config startup-config Example: <pre>switch# copy running-config startup-config</pre>	Copies the running configuration to the startup configuration.

Related Topics

[Enabling the 802.1X Feature](#), on page 11

[Disabling 802.1X Authentication on the Cisco NX-OS Device](#), on page 23

Resetting the 802.1X Interface Configuration to the Default Values

You can reset the 802.1X configuration for an interface to the default values.

Before you begin

Enable the 802.1X feature on the Cisco NX-OS device.

SUMMARY STEPS

1. **configure terminal**
2. **interface ethernet *slot/port***
3. **dot1x default**
4. **exit**
5. (Optional) **show dot1x all**
6. (Optional) **copy running-config startup-config**

DETAILED STEPS**Procedure**

	Command or Action	Purpose
Step 1	configure terminal Example: <pre>switch# configure terminal switch(config)#</pre>	Enters global configuration mode.
Step 2	interface ethernet <i>slot/port</i> Example: <pre>switch(config)# interface ethernet 2/1 switch(config-if)</pre>	Selects the interface to configure and enters interface configuration mode.
Step 3	dot1x default Example: <pre>switch(config-if)# dot1x default</pre>	Reverts to the 802.1X configuration default values for the interface.
Step 4	exit Example: <pre>switch(config-if)# exit switch(config)#</pre>	Exits configuration mode.
Step 5	(Optional) show dot1x all Example: <pre>switch(config)# show dot1x all</pre>	Displays all 802.1X feature status and configuration information.
Step 6	(Optional) copy running-config startup-config Example: <pre>switch(config)# copy running-config startup-config</pre>	Copies the running configuration to the startup configuration.

Related Topics

[Enabling the 802.1X Feature](#), on page 11

Setting the Maximum Authenticator-to-Supplicant Frame Retransmission Retry Count for an Interface

You can set the maximum number of times that the Cisco NX-OS device retransmits authentication requests to the supplicant on an interface before the session times out. The default is 2 times and the range is from 1 to 10.

Before you begin

Enable the 802.1X feature on the Cisco NX-OS device.

SUMMARY STEPS

1. **configure terminal**
2. **interface ethernet** *slot/port*
3. **dot1x max-req** *count*
4. **exit**
5. (Optional) **show dot1x all**
6. (Optional) **copy running-config startup-config**

DETAILED STEPS

Procedure

	Command or Action	Purpose
Step 1	configure terminal Example: <pre>switch# configure terminal switch(config)#</pre>	Enters global configuration mode.
Step 2	interface ethernet <i>slot/port</i> Example: <pre>switch(config)# interface ethernet 2/1 switch(config-if)#</pre>	Selects the interface to configure and enters interface configuration mode.
Step 3	dot1x max-req <i>count</i> Example: <pre>switch(config-if)# dot1x max-req 3</pre>	Changes the maximum authorization request retry count. The default is 2 times and the range is from 1 to 10. Note Make sure that the dot1x port-control interface configuration command is set to auto for the specified interface.
Step 4	exit Example: <pre>switch(config)# exit switch#</pre>	Exits interface configuration mode.

	Command or Action	Purpose
Step 5	(Optional) show dot1x all Example: switch# show dot1x all	Displays all 802.1X feature status and configuration information.
Step 6	(Optional) copy running-config startup-config Example: switch(config)# copy running-config startup-config	Copies the running configuration to the startup configuration.

Related Topics

[Enabling the 802.1X Feature](#), on page 11

Enabling RADIUS Accounting for 802.1X Authentication

You can enable RADIUS accounting for the 802.1X authentication activity.

Before you begin

Enable the 802.1X feature on the Cisco NX-OS device.

SUMMARY STEPS

1. **configure terminal**
2. **dot1x radius-accounting**
3. **exit**
4. (Optional) **show dot1x**
5. (Optional) **copy running-config startup-config**

DETAILED STEPS**Procedure**

	Command or Action	Purpose
Step 1	configure terminal Example: switch# configure terminal switch(config)#	Enters global configuration mode.
Step 2	dot1x radius-accounting Example: switch(config)# dot1x radius-accounting	Enables RADIUS accounting for 802.1X. The default is disabled.
Step 3	exit Example: switch(config)# exit switch#	Exits configuration mode.

	Command or Action	Purpose
Step 4	(Optional) show dot1x Example: switch# show dot1x	Displays the 802.1X configuration.
Step 5	(Optional) copy running-config startup-config Example: switch# copy running-config startup-config	Copies the running configuration to the startup configuration.

Related Topics

[Enabling the 802.1X Feature](#), on page 11

Configuring AAA Accounting Methods for 802.1X

You can enable AAA accounting methods for the 802.1X feature.

Before you begin

Enable the 802.1X feature on the Cisco NX-OS device.

SUMMARY STEPS

1. **configure terminal**
2. **aaa accounting dot1x default group *group-list***
3. **exit**
4. (Optional) **show aaa accounting**
5. (Optional) **copy running-config startup-config**

DETAILED STEPS

Procedure

	Command or Action	Purpose
Step 1	configure terminal	Enters global configuration mode.
Step 2	aaa accounting dot1x default group <i>group-list</i>	Configures AAA accounting for 802.1X. The default is disabled. The <i>group-list</i> argument consists of a space-delimited list of group names. The group names are the following: <ul style="list-style-type: none"> • radius—For all configured RADIUS servers. • <i>named-group</i>—Any configured RADIUS server group name.
Step 3	exit	Exits configuration mode.

	Command or Action	Purpose
Step 4	(Optional) <code>show aaa accounting</code>	Displays the AAA accounting configuration.
Step 5	(Optional) <code>copy running-config startup-config</code>	Copies the running configuration to the startup configuration.

Example

This example shows how to enable the 802.1x feature:

```
switch# configure terminal
switch(config)# aaa accounting dot1x default group radius
switch(config)# exit
switch# show aaa accounting
switch# copy running-config startup-config
```

Related Topics

[Enabling the 802.1X Feature](#), on page 11

Setting the Maximum Reauthentication Retry Count on an Interface

You can set the maximum number of times that the Cisco NX-OS device retransmits reauthentication requests to the supplicant on an interface before the session times out. The default is 2 times and the range is from 1 to 10.

Before you begin

Enable the 802.1X feature on the Cisco NX-OS device.

SUMMARY STEPS

1. `configure terminal`
2. `interface ethernet slot/port`
3. `dot1x max-reauth-req retry-count`
4. `exit`
5. (Optional) `show dot1x all`
6. (Optional) `copy running-config startup-config`

DETAILED STEPS

Procedure

	Command or Action	Purpose
Step 1	configure terminal Example: <pre>switch# configure terminal switch(config)#</pre>	Enters global configuration mode.

	Command or Action	Purpose
Step 2	interface ethernet slot/port Example: switch(config)# interface ethernet 2/1 switch(config-if)#	Selects the interface to configure and enters interface configuration mode.
Step 3	dot1x max-reauth-req retry-count Example: switch(config-if)# dot1x max-reauth-req 3	Changes the maximum reauthentication request retry count. The default is 2 times and the range is from 1 to 10.
Step 4	exit Example: switch(config)# exit switch#	Exits interface configuration mode.
Step 5	(Optional) show dot1x all Example: switch# show dot1x all	Displays all 802.1X feature status and configuration information.
Step 6	(Optional) copy running-config startup-config Example: switch(config)# copy running-config startup-config	Copies the running configuration to the startup configuration.

Related Topics

[Enabling the 802.1X Feature](#), on page 11

Verifying the 802.1X Configuration

To display 802.1X information, perform one of the following tasks:

Command	Purpose
show dot1x	Displays the 802.1X feature status.
show dot1x all [details statistics summary]	Displays all 802.1X feature status and configuration information.
show dot1x interface ethernet slot/port [details statistics summary]	Displays the 802.1X feature status and configuration information for an Ethernet interface.
show running-config dot1x [all]	Displays the 802.1X feature configuration in the running configuration.
show startup-config dot1x	Displays the 802.1X feature configuration in the startup configuration.

For detailed information about the fields in the output from these commands, see the *Cisco NX-OS Security Command Reference* for your platform.

Monitoring 802.1X

You can display the statistics that the Cisco NX-OS device maintains for the 802.1X activity.

Before you begin

Enable the 802.1X feature on the Cisco NX-OS device.

SUMMARY STEPS

1. `show dot1x {all | interface ethernet slot/port} statistics`

DETAILED STEPS

Procedure

	Command or Action	Purpose
Step 1	<code>show dot1x {all interface ethernet slot/port} statistics</code> Example: switch# show dot1x all statistics	Displays the 802.1X statistics.

Related Topics

[Enabling the 802.1X Feature](#), on page 11

Configuration Example for 802.1X

The following example shows how to configure 802.1X for an access port:

```
feature dot1x
aaa authentication dot1x default group rad2
interface Ethernet2/1
dot1x pae-authenticator
dot1x port-control auto
```

The following example shows how to configure 802.1X for a trunk port:

```
feature dot1x
aaa authentication dot1x default group rad2
interface Ethernet2/1
dot1x pae-authenticator
dot1x port-control auto
dot1x host-mode multi-host
```



Note Repeat the `dot1x pae authenticator` and `dot1x port-control auto` commands for all interfaces that require 802.1X authentication.

Additional References for 802.1X

This section includes additional information related to implementing 802.1X.

Related Documents

Related Topic	Document Title
Cisco NX-OS Licensing	<i>Cisco NX-OS Licensing Guide</i>
Command reference	<i>Cisco Nexus 7000 Series NX-OS Security Command Reference</i>
VRF configuration	<i>Cisco Nexus 7000 Series NX-OS Unicast Routing Configuration Guide</i>

Standards

Standards	Title
IEEE Std 802.1X- 2004 (Revision of IEEE Std 802.1X-2001)	<i>802.1X IEEE Standard for Local and Metropolitan Area Networks Port-Based Network Access Control</i>
RFC 2284	<i>PPP Extensible Authentication Protocol (EAP)</i>
RFC 3580	<i>IEEE 802.1X Remote Authentication Dial In User Service (RADIUS) Usage Guidelines</i>

MIBs

- IEEE8021-PAE-MIB

Feature History for 802.1X

This table lists the release history for this feature:

Table 2: Feature History for 802.1X

Feature Name	Releases	Feature Information
802.1X	6.0(1)	No change from Release 5.2.

