



## Product Overview

The Catalyst 2960-X family of switches are Ethernet switches to which you can connect devices such as Cisco IP Phones, Cisco Wireless Access Points, workstations, and other network devices such as servers, routers, and other switches.

Some models of the switches support stacking through the Cisco FlexStack technology. Unless otherwise noted, the term *switch* refers to a standalone switch and to a switch stack.

This chapter contains these topics:

- [Switch Models, on page 1](#)
- [Front Panel, on page 2](#)
- [Rear Panel, on page 12](#)
- [Management Options, on page 17](#)
- [Network Configurations, on page 18](#)

## Switch Models

**Table 1: Catalyst 2960-X Switch Models and Descriptions**

Switch Model	Supported Software Image	Description
Catalyst 2960X-48FPD-L	LAN Base	48 10/100/1000 Power over Ethernet Plus (PoE+) ports (PoE budget of 740 W) and 2 small form-factor pluggable (SFP)+ module slots.
Catalyst 2960X-48LPD-L <sup>1</sup>	LAN Base	48 10/100/1000 PoE+ ports (PoE budget of 370 W) and 2 SFP+ module slots.
Catalyst 2960X-24PD-L <sup>1</sup>	LAN Base	24 10/100/1000 PoE+ ports (PoE budget of 370 W) and 2 SFP+ module slots.
Catalyst 2960X-48TD-L <sup>1</sup>	LAN Base	48 10/100/1000 ports and 2 SFP+ module slots.

Switch Model	Supported Software Image	Description
Catalyst 2960X-24TD-L <sup>1</sup>	LAN Base	24 10/100/1000 ports and 2 SFP+ module slots.
Catalyst 2960X-48FPS-L <sup>1</sup>	LAN Base	48 10/100/1000 PoE+ ports (PoE budget of 740 W) and 4 SFP module slots.
Catalyst 2960X-48LPS-L <sup>1</sup>	LAN Base	48 10/100/1000 PoE+ ports (PoE budget of 370 W) and 4 SFP module slots.
Catalyst 2960X-24PS-L <sup>1</sup>	LAN Base	24 10/100/1000 PoE+ ports (PoE budget of 370 W) and 4 SFP module slots.
Catalyst 2960X-48TS-L <sup>1</sup>	LAN Base	48 10/100/1000 ports and 4 SFP module slots.
Catalyst 2960X-24TS-L <sup>1</sup>	LAN Base	24 10/100/1000 ports and 4 SFP module slots.
Catalyst 2960X-48TS-LL	LAN Lite	48 10/100/1000 ports and 2 SFP module slots.
Catalyst 2960X-24TS-LL	LAN Lite	24 10/100/1000 ports and 2 SFP module slots.

<sup>1</sup> Support Cisco FlexStack technology.

<sup>2</sup> SFP+ = 10-Gigabit uplink.

<sup>3</sup> SFP = 1-Gigabit uplink.

## Front Panel

This section describes the front panel components:

- 24 or 48 downlink ports of one of these types:
  - 10/100/1000
  - 10/100/1000 PoE+
- SFP ports
- USB Type A connectors
- USB mini-Type B (console) port
- Ethernet management port
- RJ-45 console port
- LEDs

- Mode button

**Figure 1: Catalyst 2960X Front Panel**

The Catalyst 2960X switch is shown here as an example. Other switches have similar components.

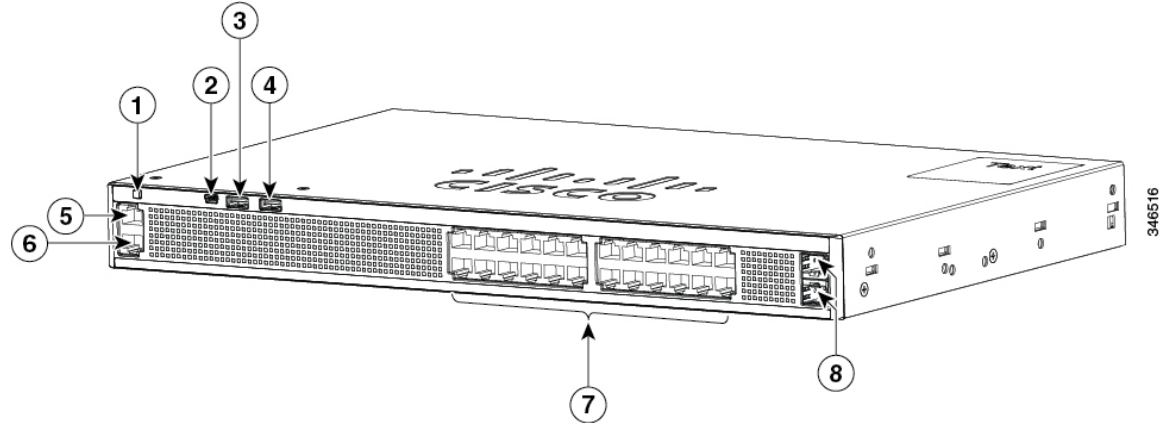

1	Mode button	5	Ethernet management port
2	USB mini-Type B (console) port	6	RJ-45 console port
3	USB Type A port	7	10/100/1000 PoE+ ports
4	USB Type A port	8	SFP module slots

## PoE and PoE+ Ports

The ports provide PoE+ support for devices compliant with IEEE 802.3af, IEEE 802.3at, and ePoE and also provide Cisco prestandard PoE support for Cisco IP Phones and Cisco Aironet Access Points.

The maximum switch power output is either 740 W or 370 W, depending on the switch model. Intelligent power management allows flexible power allocation across all ports.

For switches with a 740 W power budget, you can budget the PoE and PoE+:

- 15.4 W of PoE output on 48 ports
- 30 W of PoE+ on 24 ports

For switches with a 370 W power budget, you can budget the PoE and PoE+:

- 15.4 W of PoE output on 24 ports
- 7.7 W of PoE output on 48 ports
- 30 W of PoE+ on 12 ports
- Total power budget can be allocated among the ports

On a per-port basis, you control whether or not a port automatically provides power when an IP phone or an access point is connected.

The PoE ports use RJ-45 connectors with Ethernet pinouts. The maximum cable length is 328 feet (100 meters). The 10BASE-T, 100BASE-TX, 1000BASE-T traffic requires Category 5, Category 5e, or Category 6 unshielded twisted pair (UTP) cable. The 10BASE-T traffic can use Category 3 or Category 4 UTP cable.

Cisco intelligent power management capabilities include enhanced power negotiation, power reservation, and per-port power policing. For information about configuring and monitoring PoE ports, see the switch software configuration guide on Cisco.com.



**Note** The output of the PoE circuit has been evaluated as a Limited Power Source (LPS) per IEC 60950-1.

## 10/100/1000 Ports

The 10/100/1000 ports use RJ-45 connectors with Ethernet pinouts. The 10BASE-T, 100BASE-TX, 1000BASE-T traffic requires Category 5 or Category 5e twisted pair (UTP) cable. The 10BASE-T traffic can use Category 3 or Category 4 UTP cable.

### Related Topics

[10/100/1000 Port Connections](#)

## Management Ports

The management ports connect the switch to a PC running Microsoft Windows or to a terminal server.

- Ethernet management port.
- RJ-45 console port (EIA/TIA-232).
- USB mini-Type B console port (5-pin connector).

The 10/100 Ethernet management port connection uses a standard RJ-45 crossover or straight-through cable. The RJ-45 console port connection uses the supplied RJ-45-to-DB-9 female cable. The USB console port connection uses a USB Type A to 5-pin mini-Type B cable. The USB console interface speeds are the same as the RJ-45 console interface speeds.

If you use the USB mini-Type B console port, the Cisco Windows USB device driver must be installed on any PC connected to the console port (for operation with Microsoft Windows). Mac OS X or Linux do not require special drivers.

The 4-pin mini-Type B connector resembles the 5-pin mini-Type B connectors. They are not compatible. Use only the 5-pin mini-Type B.

**Figure 2: USB Mini-Type B Port**

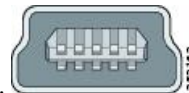

This illustration shows a 5-pin mini-Type B USB port.

With the Cisco Windows USB device driver, you can connect and disconnect the USB cable from the console port without affecting Windows HyperTerminal operations.

The console output always goes to both the RJ-45 and the USB console connectors, but the console input is active on only one of the console connectors at any one time. The USB console takes precedence over the

RJ-45 console. When a cable is connected into the USB console port, the RJ-45 console port becomes inactive. Conversely, when the USB cable is disconnected from the USB console port, the RJ-45 port becomes active.

You can use the command-line interface (CLI) to configure an inactivity timeout which reactivates the RJ-45 console if the USB console has been activated and no input activity has occurred on the USB console for a specified time.

After the USB console deactivates due to inactivity, you cannot use the CLI to reactivate it. Disconnect and reconnect the USB cable to reactivate the USB console. For information on using the CLI to configure the USB console interface, see the software guide.

## USB Type A Port

The USB Type A port provides access to external USB flash devices (also known as thumb drives or USB keys).

The port supports Cisco USB flash drives with capacities from 128 MB to 8 GB (USB devices with port densities of 128 MB, 256 MB, 1 GB, 4 GB, and 8 GB are supported). When combined with stacking, you can upgrade other switches in the stack from an USB key inserted in any switch within the stack. Cisco IOS software provides standard file system access to the flash device: read, write, erase, and copy, as well as the ability to format the flash device with a FAT file system.

It provides you with the ability to automatically upgrade the internal flash with the USB drive's configuration and image for emergency switch recovery using USB auto-upgrade. This feature checks the internal flash for a bootable image and configuration and if either image or the configuration is not available, then the USB drive is checked for boot images and configuration. If the boot image and configuration are available, these are copied to flash for the reboot.

## SFP and SFP+ Module Slots

The switch has either two or four 1-Gigabit SFP or two 10-Gigabit SFP+ module slots. The slots marked *SFP+* support both SFP and SFP+ modules. The *SFP* slots support only the SFP modules.

For Cisco SFP and SFP+ modules documentation, including compatibility matrixes, refer to this URL: [http://www.cisco.com/en/US/products/hw/modules/ps5455/products\\_device\\_support\\_tables\\_list.html](http://www.cisco.com/en/US/products/hw/modules/ps5455/products_device_support_tables_list.html)

## LEDs

You can use the switch LEDs to monitor switch activity and its performance.

**Figure 3: Switch LEDs and Mode Button for the Catalyst 2960-X Switch**

This figure shows the switch LEDs and the Mode button that you use to select a port mode.

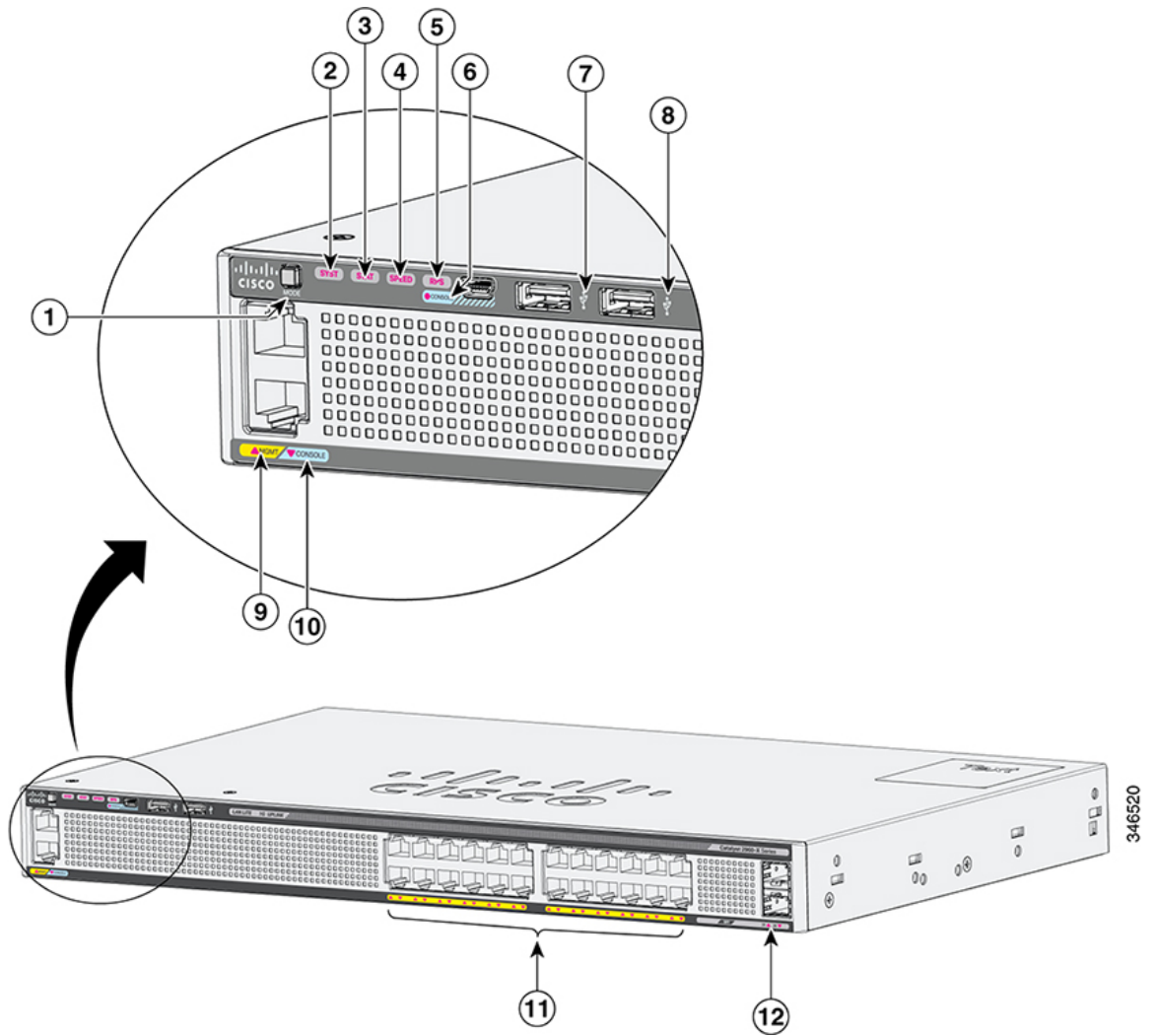

1	Mode button	7	USB Type A port
2	SYST LED	8	USB Type A port
3	STAT LED	9	MGMT LED
4	SPEED LED	10	CONSOLE LED
5	RPS LED <sup>4</sup>	11	Port LEDs
6	USB mini-Type B console port LED	12	SFP port LEDs

<sup>4</sup> RPS = redundant power system—only on switch models that support RPS.

## System LED

**Table 2: System LED**

Color	System Status
Off	System is not powered on.
Green	System is operating normally.
Blinking green	POST in progress.
Amber	System is receiving power but is not functioning properly.
Blinking amber	System is sleep mode.

## RPS LED

The RPS LED is only available on switch models that have an RPS port .

**Table 3: RPS LED**

Color	RPS Status
Off	RPS is off or not properly connected.
Green	RPS is connected and can provide back-up power.
Blinking green	RPS is connected but is unavailable. It is providing power to another device (redundancy has been allocated to the other device).
Amber	The RPS is in standby mode or in a fault condition. See the RPS documentation.
Blinking amber	The power supply in a switch has failed, and the RPS is providing power to the switch (redundancy has been allocated to this device).

## Master LED

This table describes the master LEDs.

**Table 4: Master LED**

Port Mode	Description
Off	Switch is not the stack master.
Green	Switch is the stack master or a standalone switch.

Port Mode	Description
Amber	An error occurred when the stack was electing the stack master switch, or another type of stack error occurred.

## Port LEDs and Modes

The port and module slots each has a port LED. As a group or individually, the LEDs show information about the switch and about the ports.

**Table 5: Port Mode LEDs**

Mode LED	Port Mode	Description
STAT	Port status	The port status. This is the default mode.
SPEED	Port speed	The port operating speed: 10, 100, 1000 Mb/s, or 10 Gb/s.
STACK	Stack member status	The stack member status.
	Stack port status	The stack port status.
PoE	PoE port power	The PoE status.

To select or change a mode, press the Mode button until the desired mode is highlighted. When you change port modes, the meanings of the port LED colors also change.



**Table 6: Meanings of LED Colors in Different Modes**

<b>Port Mode</b>	<b>Port LED Color</b>	<b>Meaning</b>
PoE	Off	PoE is off. If the powered device is receiving power from an AC power source, the port LED is off even if the powered device is connected to the switch port.
	Green	PoE is on. The port LED is green only when the switch port is providing power.
	Alternating green and amber	PoE is denied because providing power to the powered device will exceed the switch power capacity.
	Blinking amber	PoE is off due to a fault. Noncompliant cabling or powered devices can cause a PoE port fault. Use only standard-compliant cabling to connect Cisco prestandard IP Phones and wireless access points or IEEE 802.3af-compliant devices. You must remove any cable or device that causes a PoE fault.
	Amber	PoE for the port is disabled. (PoE is enabled by default.)

Port Mode	Port LED Color	Meaning
STAT (port status)	Off	No link or port was administratively shut down.
	Green	Link present.
	Blinking green	Activity. Interface is sending or receiving data.
	Alternating green-amber	Link fault. Error frames can affect connectivity, and errors such as excessive collisions, cyclic redundancy check (CRC) errors, and alignment and jabber errors are monitored for a link-fault indication.
	Amber	Port is blocked by Spanning Tree Protocol (STP) and is not forwarding data.  After a port is reconfigured, the port LED can remain amber for up to 30 seconds as STP searches the switch for possible loops.
	Blinking amber	Port is blocked by STP and is sending and receiving packets.
SPEED	10/100/1000 ports	
	Off	Port is operating at 10 Mb/s.
	Green	Port is operating at 100 Mb/s.
	Blinking green	Port is operating at 1000 Mb/s.
	SFP module ports	
	Off	Port is operating at 10 Mb/s.
	Green	Port is operating at 100 Mb/s.
	Blinking green	Port is operating at 1000 Mb/s.
	SFP+ module ports (Applies to the Catalyst 2960X-48FPD-L, 2960X-48LPD-L, 2960X-24PD-L, 2960X-48TD-L, and the 2960X-24TD-L switches.)	
	Off	Port is not operating.
	Blinking green	Port is operating at 10 Gb/s.
	Green	Port is operating at 1 Gb/s.

Port Mode	Port LED Color	Meaning
STACK (stack member)	Off	No stack member has that member number.
	Blinking green	Stack member number.
	Green	Member numbers of other stack member switches.

If your switches are stacked and you press the Mode button on any switch, all the switches display the same selected mode. For example, if you press the Mode button on the stack master to display SPEED, all the other stack members display SPEED.

Even if PoE mode is not selected, this LED still shows PoE problems if they are detected.

## STACK LED

The STACK LED shows the sequence of member switches in a stack. Up to eight switches can be members of a stack. The first eight port LEDs show the switch member number. For example, if you press the Mode button and select Stack, the port LED 1 blinks green. The LEDs for port 2 and 3 are solid green, as these represent the member numbers of other stack members. The other port LEDs are off because there are no more members in the stack.

**Figure 4: STACK LED**

This figure shows the LEDs on the first switch, which is stack member number 1.

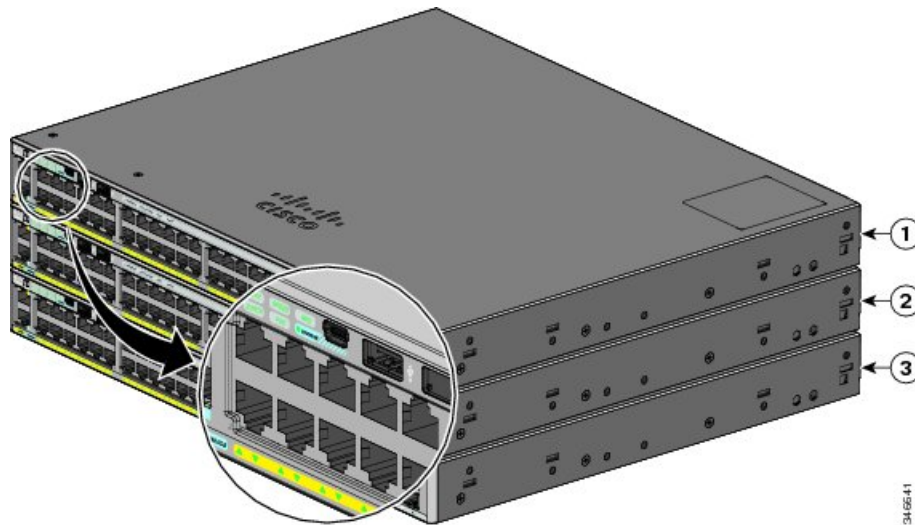

1	Stack member 1	3	Stack member 3
2	Stack member 2		

When you select the STACK LED, the respective STACK LEDs are green when the stack ports (on the switch rear panel) are up, and the respective Stack LEDs are amber when the ports are down. SFP+ module port LEDs 1 and 2 on the switch show the status for stack ports 1 and 2, respectively.

If the port LEDs are green on all the switches in the stack, the stack is operating at full bandwidth. If any port LED is not green, the stack is not operating at full bandwidth.

## Console LEDs

The console LEDs show which console port is in use. If you connect a cable to a console port, the switch automatically uses that port for console communication. If you connect two console cables, the USB console port has priority.

**Table 7: RJ-45 and USB Console LEDs**

LED	Color	Description
RJ-45 console port	Green	RJ-45 console port is active. When this LED is on, the USB console port LED is off.
	Off	The port is not active, and the USB console port is active.
USB console port	Green	USB console port is active. When this LED is on, the RJ-45 console port LED is off.
	Off	The port is not active, and the RJ-45 console port is active.

## Ethernet Management Port LED

**Table 8: Ethernet Management Port LED**

Color	Description
Green	Active link to PC.
Off	Inactive link.
Amber	POST failure.

## Rear Panel

The rear panel of the Catalyst 2960-X switches have a FlexStack module slot, a fan exhaust, an RPS connector, and an AC power connector.



**Note** The FlexStack module slot is not available on the Catalyst 2960X-48TS-LL and 2960X-24TS-LL switches.

Figure 5: Catalyst 2960-X Switch Rear Panel

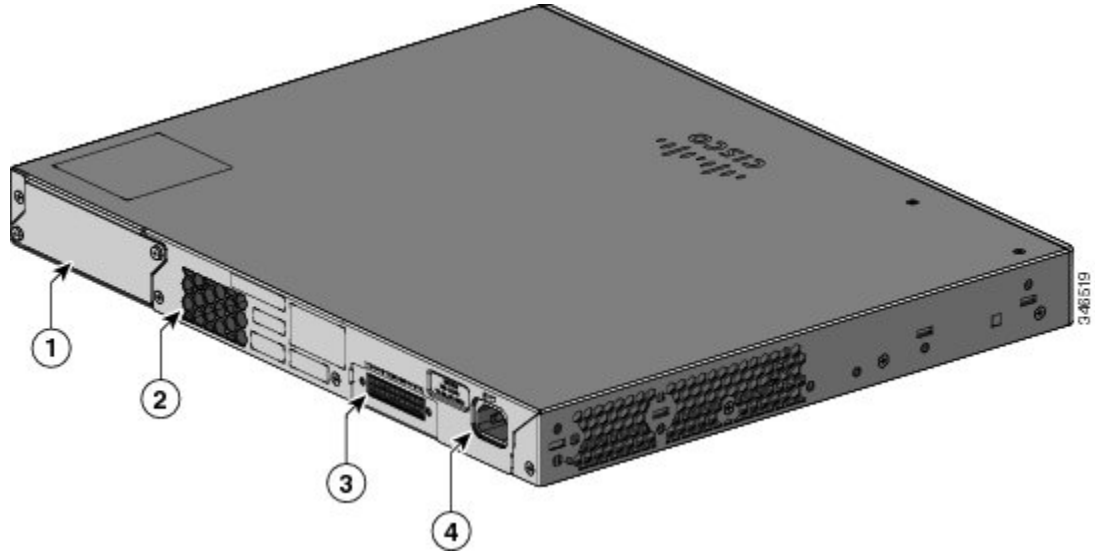

1	FlexStack module slot and cover	3	RPS Connector
2	Fan Exhaust	4	AC power connector

## FlexStack Ports and LEDs

### FlexStack-Plus Ports and LEDs

The stacking-capable switch models support stacking with the optional stack kit. It has the FlexStack-Plus module (hot-swappable) that inserts in the slot located in the switch rear panel, and a 0.5-meter FlexStack cable to connect the FlexStack-Plus module ports.

Figure 6: FlexStack-Plus Module

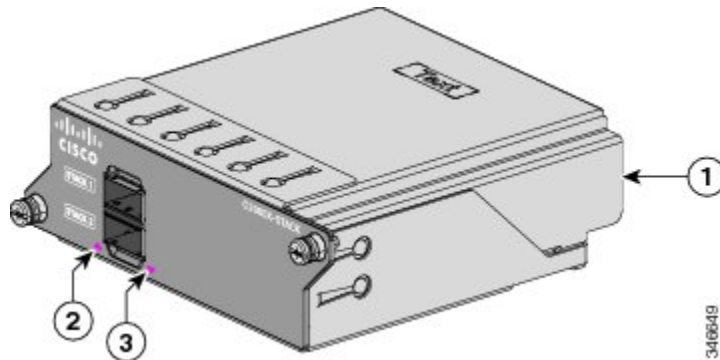

1	FlexStack-Plus module	3	LED for Stack port 2
2	LED for Stack port 1		

This table lists the FlexStack-Plus module LED colors and their meanings.

**Table 9: FlexStack-Plus Module LEDs**

Color	Description
Green	Port is active, cable is attached.
Off	The port is not active, no cable is attached.

**Table 10: Stack Configurations**

Switch	Number of Switches in the Stack	Bandwidth
Stack with Catalyst 2960-X stack-capable switches	8	80 G
	8	80 G
Mixed stack with Catalyst 2960-S and Catalyst 2960-X stack-capable switches	4	40 G

## FlexStack-Extended Ports and LEDs

### FlexStack-Extended Fiber Module

The FlexStack-Extended Fiber Module (C2960X-FIBER-STK) is used to stack switches across wiring closets on different floors of a building or across different buildings in a campus. The module allows stacking over SFP+ module ports and provides bandwidth of up to 40 Gpbs over longer distance. The FlexStack-Extended Fiber module has two SFP+ module ports. The SFP+ port enables long-reach stacking using standard multimode LR (300m) and EX (7km) optics. You should select the appropriate SFP+ module depending on the distance required between the switches.

For more information about the SFP+ transceiver modules supported on FlexStack ports, see [Compatibility Matrix](#).

Figure 7: FlexStack-Extended Fiber Module

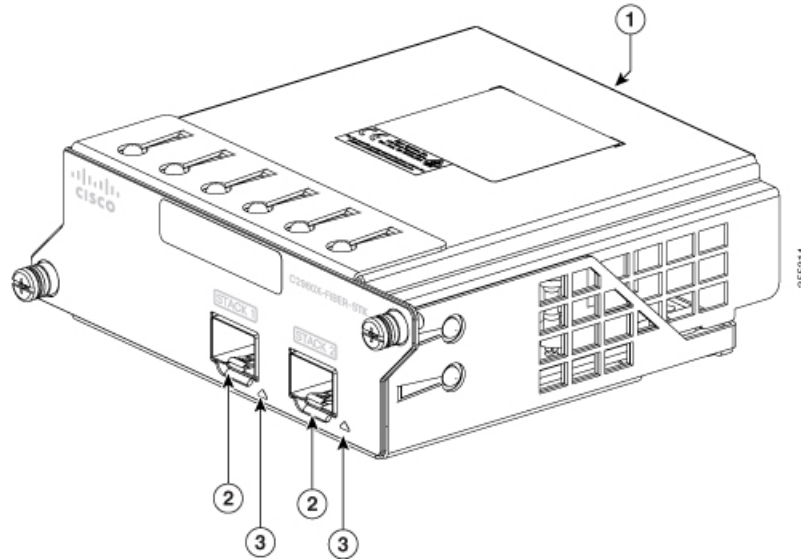

1	FlexStack-Extended Fiber module	3	LEDs for SFP+ module ports
2	SFP+ module ports		

**FlexStack-Extended Hybrid Module**

The Cisco FlexStack-Extended Hybrid module (C2960X-HYBRID-STK) has one SFP+ port and one copper FlexStack-Plus port. The copper port enables short-reach connectivity across a local stack of switches. The SFP+ port enables long-reach stacking using standard multimode LR (300m) and EX (7km) optics. You can choose the appropriate SFP+ depending on the distance between the switches.

For more information about the SFP+ transceivers supported on the FlexStack ports, see [Compatibility Matrix](#).

The copper FlexStack-Plus port allows the switch to stack with the Cisco FlexStack-Plus stacks. You can only stack Cisco Catalyst 2960-X or Cisco Catalyst 2960-XR switches. FlexStack cables of following lengths are supported.

- CAB-STK-E-0.5M= (0.5-meter cable)
- CAB-STK-E-1M= (1-meter cable)
- CAB-STK-E-3M= (3-meter cable)

Figure 8: FlexStack-Extended Hybrid Module

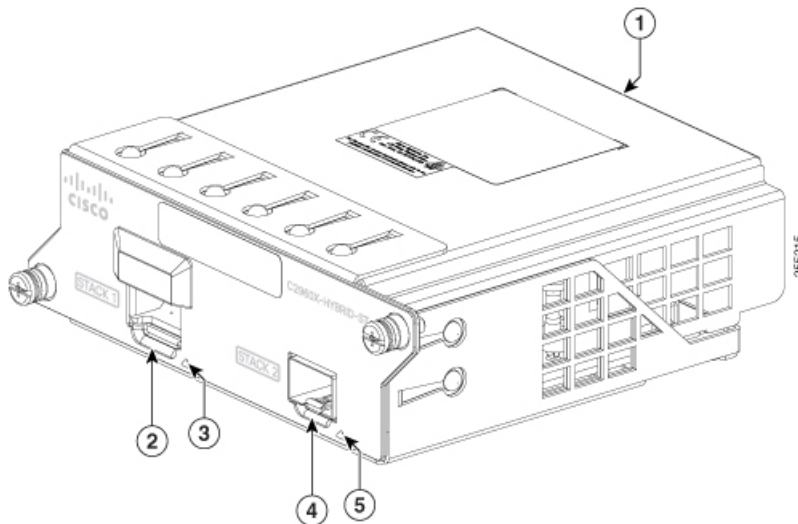

1	FlexStack-Extended Hybrid module	4	Fiber SFP+ module port
2	Copper FlexStack-Plus port	5	LED for Fiber SFP+ module port
3	LED for Copper FlexStack-Plus port		

This table lists the FlexStack-Extended module LED colors and their meanings.

Table 11: FlexStack-Extended Module LEDs

Color	Description
Green	Port link is up, but there is no packet activity.
	Port link is up and packet activity is present.
Off	Port link is down.

Table 12: Stack Configurations

Switch	Number of Switches in the Stack	Bandwidth
Stack with Catalyst 2960-X stack-capable switches	8	40 G
	8	40 G



## RPS Connector

The Cisco RPS 2300 (model PWR-RPS2300) supports the Catalyst 2960-X switch.

**Warning**

Attach only the following Cisco RPS model to the RPS receptacle: RPS2300. Statement 370

Connect the switch and the redundant power system to different AC power sources.

Use this cable for the RPS: CAB-RPS2300-E.

## Cisco RPS 2300

The Cisco RPS 2300 is a redundant power system that can support six external network devices and provide power to one or two failed devices at a time. It senses when the internal power supply of a connected device fails and provides power to the failed device, preventing loss of network traffic. For more information, see the *Cisco Redundant Power System 2300 Hardware Installation Guide* on Cisco.com at this URL:

[http://www.cisco.com/en/US/products/ps7148/prod\\_installation\\_guides\\_list.html](http://www.cisco.com/en/US/products/ps7148/prod_installation_guides_list.html)

The Cisco RPS 2300 has two output levels: -52 V and 12 V with a total maximum output power of 2300 W.

All supported and connected switches can simultaneously communicate with the RPS 2300. You can configure these RPS 2300 features through the switch software:

- Enable RPS active or standby mode for each connected switch
- Configure switch priority for RPS support
- List the connected switches and the power-supply module sizes
- Obtain reports when a switch is powered by the RPS
- Obtain status reports for the RPS power-supply module
- Read and monitor backup, failure, and exception history

## AC Power Connector

**Note**

This applies to the Catalyst 2960-X switches.

The switch is powered through the internal power supply. The internal power supply is an autoranging unit that supports input voltages between 100 and 240 VAC. Use the supplied AC power cord to plug it into an AC power outlet.

## Management Options

- Cisco Network Assistant

Cisco Network Assistant is a PC-based network management GUI application for LANs of small and medium-sized businesses. You can use the GUI to configure and manage switch clusters or standalone

switches. Cisco Network Assistant is available at no cost and can be downloaded from this URL: <http://www.cisco.com/en/US/products/ps5931/index.html>

For information on starting the Network Assistant application, see the *Getting Started with Cisco Network Assistant* guide on Cisco.com.

- Device Manager

You can use Device Manager in the switch memory to manage individual and standalone switches. This web interface provides configuration and monitoring from anywhere in your network. For information, see the switch getting started guide and the Device Manager online help.

- Cisco IOS CLI

You can configure and monitor the switch and switch cluster members from the CLI. Access the CLI by connecting your management station to the switch console port or by using Telnet from a remote management station. See the switch command reference on Cisco.com for information.

- Cisco Prime Infrastructure

Cisco Prime Infrastructure combines the wireless functionality of Cisco Prime Network Control System (NCS) and the wired functionality of Cisco Prime LAN Management Solution (LMS), with application performance monitoring and troubleshooting capabilities of Cisco Prime Assurance Manager. For more information, see the Cisco Prime Infrastructure documentation on Cisco.com.

- Catalyst Smart Operations

The Smart Install feature provides a single point of management (director) in a network. You can use it to provide a zero touch image and configuration upgrade of newly deployed switches and image and configuration downloads for any client switches. For information, see the *Cisco Smart Install Configuration Guide* on Cisco.com.

Auto Smartports macros dynamically configure ports based on the device type detected on the port. When the switch detects a new device, it applies the appropriate Auto Smartports macro on the port. For information about configuring Auto Smartports, see the switch software configuration guide on Cisco.com.

## Network Configurations

See the switch software configuration guide for network configuration concepts and examples of using the switch to create dedicated network segments and interconnecting the segments through Fast Ethernet and Gigabit Ethernet connections.