



Catalyst 3750-X and 3560-X Switch Getting Started Guide

- [About this Guide, page 1](#)
- [Box Contents, page 2](#)
- [Running Express Setup, page 3](#)
- [Managing the Switch, page 8](#)
- [Installing the Switch, page 10](#)
- [Securing the AC Power Cord \(Optional\), page 14](#)
- [Connecting the StackWise Cables \(Catalyst 3750-X Switch\), page 14](#)
- [Connecting the StackPower Cables \(Catalyst 3750-X Switch\), page 15](#)
- [Installing the Network Module \(Optional\), page 16](#)
- [Connecting the Switch Ports, page 17](#)
- [Troubleshooting, page 19](#)
- [Obtaining Documentation and Submitting a Service Request, page 20](#)

About this Guide

This guide describes how to use Express Setup to initially configure your Catalyst switch. It also covers switch management options, basic rack-mounting, stacking, port and module connections, and troubleshooting.

For more installation and configuration information, see the Catalyst 3750-X and 3560-X documentation on Cisco.com. For system requirements, important notes, limitations, open and resolved bugs, and documentation updates, see the release notes on Cisco.com.

When using the online publications, refer to the documents that match the Cisco IOS software version running on the switch.

For translations of the warnings that appear in this publication, see the *Regulatory Compliance and Safety Information for the Catalyst 3750-X and 3560-X Switches* on Cisco.com.



Americas Headquarters:
Cisco Systems, Inc., 170 West Tasman Drive, San Jose, CA 95134-1706 USA

Box Contents

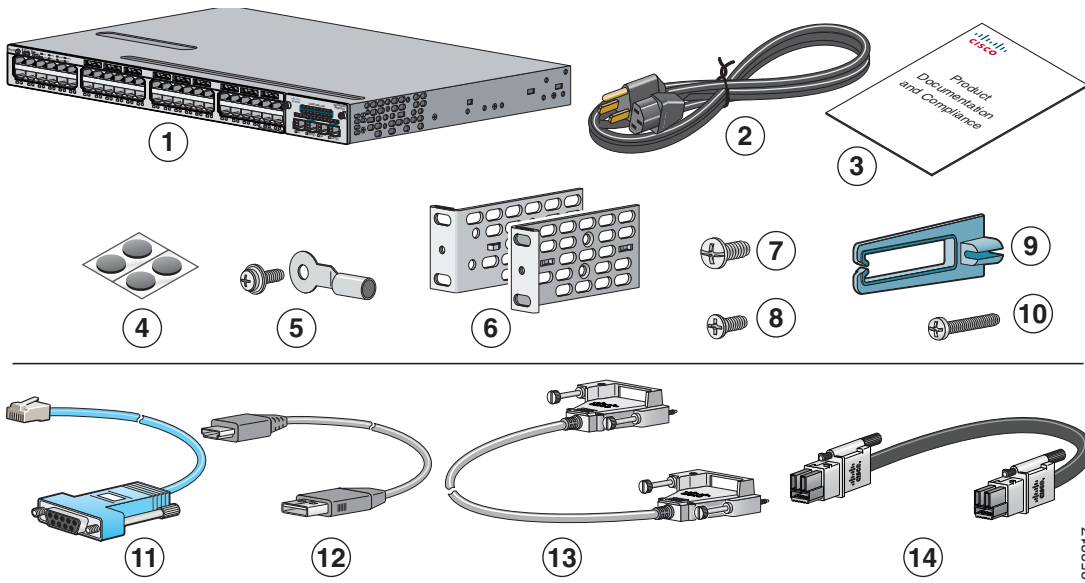

1	Catalyst WS-C3750X-48P ¹ switch with optional network module ²	8	Eight number-8 Phillips flat head screws
2	AC power cord	9	Cable guide
3	Product documentation and compliance document	10	M4.0 x 20mm Phillips pan head screw
4	Four rubber mounting feet	11	(Optional) RJ-45 console cable ²
5	Ground lug screw and ring terminal	12	(Optional) USB console cable ²
6	Two 19-inch mounting brackets	13	(Optional) StackWise cable (0.5-meter, 1-meter, or 3-meter) ²
7	Four number-12 pan head screws	14	(Optional) StackPower cable (0.305-meter or 1.5-meter) ²

1. Catalyst WS-C3750X-48 switch shown. Your switch model might look different.

2. Item is orderable.



Note

Verify that you have received these items. If any item is missing or damaged, contact your Cisco representative or reseller for instructions.

Running Express Setup

You should use Express Setup to enter the initial IP information. This enables the switch to connect to local routers and the Internet. You can access the switch through the IP address for further configuration.

Note

To use the CLI-based initial setup program, see Appendix C, “*Configuring the Switch with the CLI-Based Setup Program*,” in the switch hardware guide.

You need this equipment:

- PC with Windows Vista, XP, or 2000
- Browser (Internet Explorer 5.5, 6.0, 7.0, Firefox 1.5, 2.0, 3.0 or later) with JavaScript enabled
- Straight-through or crossover Category 5 Ethernet cable

Note

Before running Express Setup, disable any pop-up blockers or proxy settings in your browser and any wireless client running on your PC.

Step 1 Make sure that nothing is connected to the switch.

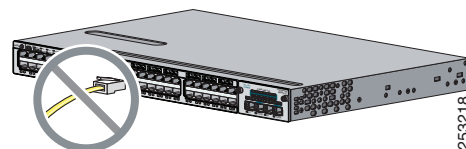

Step 2 During Express Setup, the switch acts as a DHCP server. If your PC has a static IP address, temporarily change your PC settings before you use DHCP.

Note Write down the static IP address. You will need this IP address in [Step 13](#).

Step 3 Power the switch.

AC power switches: Plug the AC power cord into the switch power supply and into a grounded AC outlet.

DC power switches: See the wiring instructions in the hardware installation guide on Cisco.com.

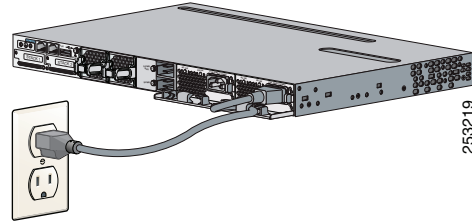
**Step 4** Approximately 30 seconds after the switch powers on, it begins the power-on self-test (POST), which can take up to 5 minutes to complete.

During POST, the SYSTEM LED blinks green, and the XPS, STATUS, DUPLEX, and SPEED LEDs turn solid green.

When POST is complete, the SYSTEM LED is green, the MAST LED is green if the switch is acting as stack master, and the other LEDs turn off.

Note Before going to the next step, wait until POST is complete.

Troubleshooting:

If the SYST LED blinks green, does not turn green, or turns amber, contact your Cisco representative or reseller. The switch failed the power-on self-test (POST).

Step 5 Press and hold the Mode button until all the LEDs next to the Mode button turn green. (The XPS LED remains off on some switch models.)

You might need to hold the button for more than 3 seconds.

The switch is now in Express Setup mode.

Troubleshooting:

If the LEDs next to the Mode button blink when you press the button, release it. Blinking LEDs mean that the switch is already configured and cannot go into Express Setup mode. For more information, see the [“Resetting the Switch to the Default Settings”](#) section on page 20.

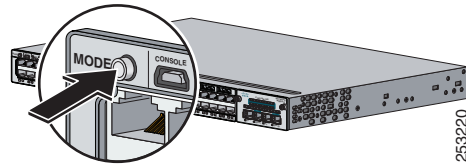

Step 6 Connect a Category 5 Ethernet cable to a port:

- Any 10/100/1000 Ethernet port on the switch front panel
- The RJ-45 management port on the switch rear panel

Connect the other end of the cable to the Ethernet port on your PC.

Wait until the port LEDs on the switch and your PC or laptop are green or blinking green. Green LEDs mean a successful connection.

Troubleshooting:

If the port LEDs do not turn green after about 30 seconds, make sure that:

- You connected the Ethernet cable to one of the downlink switch ports (not to the console port).
- You are using an undamaged Category 5 or 6 Ethernet cable.
- The other device is turned on.

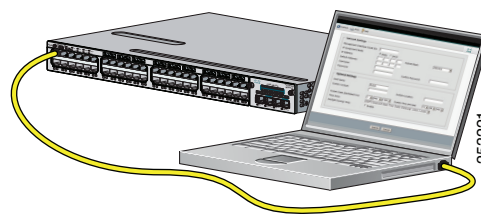
**Step 7** Start a browser session on the PC, and enter the IP address **10.0.0.1**. When prompted, enter the default password, *cisco*.

Note The switch ignores text in the username field.

The Express Setup window appears.

Troubleshooting:

If the Express Setup window does not appear, make sure that any browser pop-up blockers or proxy settings are disabled and that any wireless client is disabled on your PC or laptop.

Step 8 Enter this information in the Network Settings fields:

Note All entries must be in English letters.

- In the Management Interface (VLAN ID) field, the default is 1.

Note We recommend that you use the default VLAN value. During Express Setup, VLAN 1 is the only VLAN on the switch. Enter a new VLAN ID only if you want to change the management interface through which you manage the switch. The VLAN ID range is 1 to 1001.

- In the IP Address field, enter the switch IP address.
- In the Subnet Mask field, click the drop-down arrow, and select a subnet mask.
- In the Default Gateway field, enter the IP address for the default gateway (router).
- Enter your password in the Switch Password field. The password can be from 1 to 25 alphanumeric characters, can start with a number, is case sensitive, allows embedded spaces, but does not allow spaces at the beginning or end. In the Confirm Switch Password field, enter your password again.

Note You must change the default password, *cisco*.

(Optional) Enter this information in the Ethernet Management Port Settings fields:

- In the IP Address field, enter the IP address of the Ethernet management port. In the IP Subnet Mask field, click the drop-down arrow, and select an IP Subnet Mask.

Step 9 (Optional) You can enter the Optional Settings information now or enter it later by using the device manager interface.

You can enter other administrative settings in the Optional Settings fields. For example, the optional administrative settings identify and synchronize the switch for enhanced management. NTP automatically synchronizes the switch clock with the network clock. You can manually set the system clock if the switch should have different settings.

- Step 10** (Optional) You can select the Advanced Settings tab on the Express Setup window and enter the advanced settings now or enter them later by using the device manager interface.

The screenshot shows the 'Advanced Settings' tab in the Express Setup window. It contains the following fields and options:

- Telnet Access:** Radio buttons for 'Enable' and 'Disable' (selected).
- Telnet Password:** Text input field.
- Confirm Telnet Password:** Text input field.
- SNMP:** Radio buttons for 'Enable' and 'Disable' (selected).
- SNMP Read Community:** Text input field.
- SNMP Write Community:** Text input field.
- System Contact:** Text input field.
- System Location:** Text input field.
- IPv6 Settings:** A checkbox labeled 'Enable IPv6' with a help icon.

A vertical label '157718' is positioned on the right side of the form.

- In the Telnet Access field, click Enable if you are going to use Telnet to manage the switch by using the command-line interface (CLI). If you enable Telnet access, you must enter a Telnet password.
- In the Telnet Password field, enter a password. The Telnet password can be from 1 to 25 alphanumeric characters, is case sensitive, allows embedded spaces, but does not allow spaces at the beginning or end. In the Confirm Telnet Password field, re-enter the Telnet password.
- In the SNMP field, click Enable to enable Simple Network Management Protocol (SNMP). Enable SNMP only if you plan to manage switches by using CiscoWorks 2000 or another SNMP-based network-management system.
- If you enable SNMP, you must enter a community string in the SNMP Read Community field, the SNMP Write Community field, or both. SNMP community strings authenticate access to MIB objects. Embedded spaces are not allowed in SNMP community strings. When you set the SNMP read community, you can access SNMP information, but you cannot change it. When you set the SNMP write community, you can both access and change SNMP information.
- In the System Contact and System Location fields, enter a contact name and the wiring closet, floor, or building where the switch is located.
- (Optional) In the Enable IPv6 field, click Enable to enable IPv6 on the switch.

Note Enabling IPv6 restarts the switch when you complete Express Setup.

- Step 11** Click **Submit** to save your changes and wait 60 seconds to complete the initial setup.

After you click Submit and 60 seconds elapsed :

- The switch is configured and exits Express Setup mode.
- The browser displays a warning message and tries to connect with the earlier switch IP address. Typically, connectivity between the PC and the switch is lost because the configured switch IP address is in a different subnet from the IP address on the PC.

For more information about Express Setup fields, see the online help for the Express Setup window.

- Step 12** Disconnect the switch from the PC, and install the switch in your network. See the [“Installing the Switch” section on page 10](#).

- Step 13** If you changed the static IP address on your PC in [Step 2](#), change it to the previously configured static IP address.

Step 14 See the “[Managing the Switch](#)” section on page 8 for information about configuring and managing the switch.

To display the device manager:

1. Start a web browser on your PC or laptop.
2. Enter the switch IP address, username, and password assigned in [Step 8](#) in the browser, and press **Enter**. The device manager page appears.

Troubleshooting:

If the device manager does not appear:

- Confirm that the port LED for the switch port connected to your network is green.
 - Confirm that the PC or laptop that you are using has network connectivity by connecting it to a well-known web server in your network. If there is no network connection, troubleshoot the network settings on the PC or laptop.
 - Make sure that the switch IP address in the browser is correct.
 - If the switch IP address in the browser is correct, the switch interface LED is green, and the PC or laptop has network connectivity, continue troubleshooting by reconnecting the PC or laptop to the switch. Configure a static IP address on the PC or laptop that is in the same subnet as the switch IP address.
 - When the LED on the switch port connected to the PC or laptop is green, re-enter the IP address of the switch in a browser to display the device manager. When the device manager appears, you can continue with the configuration.
-

Managing the Switch

After completing Express Setup and installing the switch in your network, you can use these options for configuration:

- [Device Manager](#)
- [Cisco Network Assistant](#)
- [Command-Line Interface](#)
- [Other Management Options](#)

Device Manager

The simplest way to manage the switch is by using the device manager in the switch memory. This is a web interface that offers quick configuration and monitoring. You can access it through a web browser.

Follow these steps:

1. Launch a web browser on your PC or laptop.
2. Enter the switch IP address in the web browser, and press **Enter**. The device manager page appears.
3. Use the device manager for basic switch configuration and monitoring. Refer to the device manager online help for more information.

Cisco Network Assistant

Cisco Network Assistant is a software program that you download from Cisco.com and run on your PC. It offers advanced options for configuring and monitoring multiple devices, including switches, switch clusters, switch stacks, routers, and access points. Network Assistant is free—there is no charge to download, install, or use it.

1. Go to this Web address: <http://www.cisco.com/en/US/products/ps5931/index.html>.



Note You must be a registered Cisco.com user, but you need no other access privileges.

2. Find the Network Assistant installer.
3. Download the Network Assistant installer, and run it. (You can run it directly from the Web if your browser offers this choice.)
4. When you run the installer, follow the instructions. In the final panel, click **Finish**.

Refer to the Network Assistant online help and the getting started guide for more information.

Command-Line Interface

You can enter Cisco IOS commands and parameters through the CLI. Use one of these options to it:

- [USB Console Port](#)
- [Ethernet Console Port](#)
- [Management Port](#)



Note You cannot use the Ethernet console port and the USB console port at the same time.

USB Console Port



Note A USB device driver must be installed the first time a Microsoft Windows-based PC is connected to the switch USB console port. See the switch hardware installation guide for instructions.

1. Connect a USB cable to the PC USB port. Connect the other end of the cable to the mini-B (5-pin-connector) USB port on the switch front panel.
2. Start a terminal-emulation program on the PC.
3. Configure the PC terminal emulation software for 9600 baud, 8 data bits, no parity, 1 stop bit, and no flow control.
4. Use the CLI to configure the switch. See the software configuration guide and the command reference.

Ethernet Console Port

1. Connect a Category 5 Ethernet cable to the PC Ethernet port. Connect the other end of the cable to the Ethernet console port on the switch rear panel.
2. Start a terminal-emulation program on the PC.
3. Configure the PC terminal emulation software for 9600 baud, 8 data bits, no parity, 1 stop bit, and no flow control.
4. Use the CLI to configure the switch. See the software configuration guide and the command reference.

Management Port

1. Connect a Category 5 Ethernet cable to the PC Ethernet port. Connect the other end of the cable to the management port on the switch rear panel.
2. Start a Telnet session on the PC.
3. Enter the switch IP address that you assigned using Express Setup.
4. Use the CLI to configure the switch. See the software configuration guide and the command reference.

Other Management Options

You can use SNMP management applications such as CiscoWorks Small Network Management Solution (SNMS) and HP OpenView to configure and manage the switch. You can manage it from an SNMP-compatible workstation that is running platforms such as HP OpenView or SunNet Manager.

The Cisco IE2100 Series Configuration Registrar is a network management device that works with embedded Cisco Networking Services (CNS) agents in the switch software. You can use the Registrar to automate initial configurations and configuration updates.

See the [“Accessing Help Online” section on page 20](#) for supporting documentation.

Installing the Switch

This section covers basic 19-inch rack-mounting. The illustrations show the Catalyst 3750X-48P switch. You can install and connect other Catalyst 3750-X and 3560-X switches as shown. See the hardware installation guide on Cisco.com.

Equipment That You Need

- Phillips screwdriver to rack-mount the switch
- Ratcheting torque screwdriver capable of 5-inch pound of torque to connect the StackWise cable

Before You Begin

Before installing the switch, verify that these guidelines are met:

- Clearance to front so that the LEDs can be read.
- AC power cord reaches from the AC power outlet to the rear-panel connector.
- Switch is rack-mounted before you install a 1100-W power supply module.
- Cabling is away from sources of electrical noise, such as radios, power lines, and fluorescent lighting. Make sure the cabling is safely away from other devices that might damage the cables. If needed, allow one RU space between devices to provide room for cabling.
- Airflow around the switch and through the vents is unrestricted.
- Temperature around the unit does not exceed 113°F (45°C). If the switch is in a closed or multirack assembly, the temperature might be higher than normal room temperature.
- Humidity around the switch does not exceed 85 percent.
- Altitude at the installation site is below 10,000 feet.
- For 10/100/1000 fixed ports, cables from the switch to connected devices are not longer than 328 feet (100 meters).
- Cooling mechanisms, such as fans and blowers in the switch, can draw dust and other particles causing contaminant buildup inside the chassis, which can result in system malfunction. Install the switch in an environment as free as possible from dust and foreign conductive material (such as metal flakes from construction activities).

Installation Warning Statements

Translations of these warning statements appear in the *Regulatory Compliance and Safety Information for the Catalyst 3750-X and 3560-X Switch* document on Cisco.com.



Warning

To prevent the switch from overheating, do not operate it in an area that exceeds the maximum recommended ambient temperature of 113°F (45°C). To prevent airflow restriction, allow at least 3 inches (7.6 cm) of clearance around the ventilation openings. Statement 17B



Warning

Do not reach into a vacant slot or chassis while you install or remove a module or a fan. Exposed circuitry could constitute an energy hazard. Statement 206



Warning

Only trained and qualified personnel should be allowed to install, replace, or service this equipment. Statement 1030

Caution

To comply with the Telcordia GR-1089 Network Equipment Building Systems (NEBS) standard for electromagnetic compatibility and safety, connect the Ethernet cables only to intrabuilding or nonexposed wiring or cabling.

Note

The grounding architecture of this product is DC-isolated (DC-I).

Attaching the Brackets

Use three (for front-mount) or four (for mid- or rear-mount) number-8 Phillips flat-head screws to attach the long side of each bracket to the switch in one of these mounting positions.

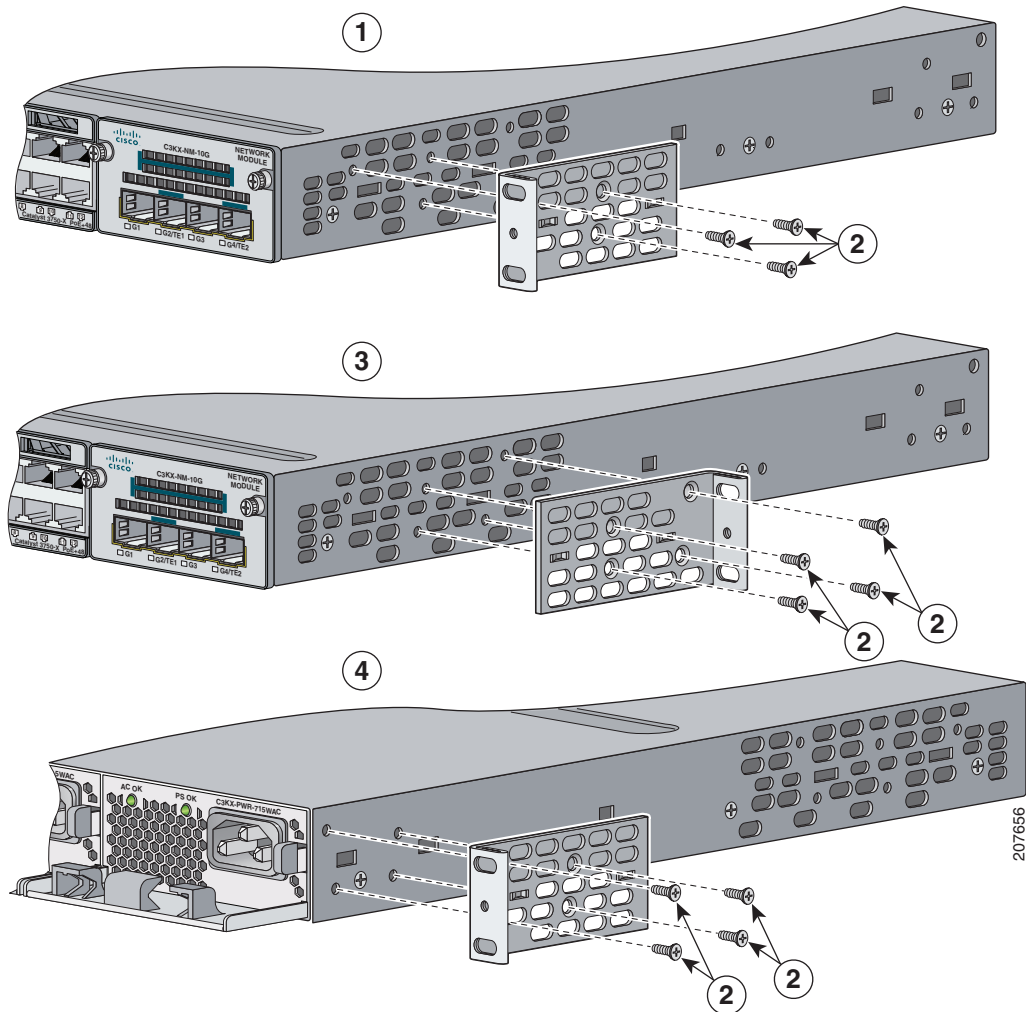

1	Front-mounting position	3	Mid-mounting position
2	Number-8 Phillips flat-head screws	4	Rear-mounting position

Rack-Mount the Switch

Use the four number-12 Phillips machine screws to attach the brackets to the rack. Use the black Phillips machine screw to attach the cable guide to the left or right bracket.



Warning

To prevent bodily injury when mounting or servicing this unit in a rack, you must take special precautions to ensure that the system remains stable. The following guidelines are provided to ensure your safety:

This unit should be mounted at the bottom of the rack if it is the only unit in the rack.

When mounting this unit in a partially filled rack, load the rack from the bottom to the top with the heaviest component at the bottom of the rack.

If the rack is provided with stabilizing devices, install the stabilizers before mounting or servicing the unit in the rack. Statement 1006

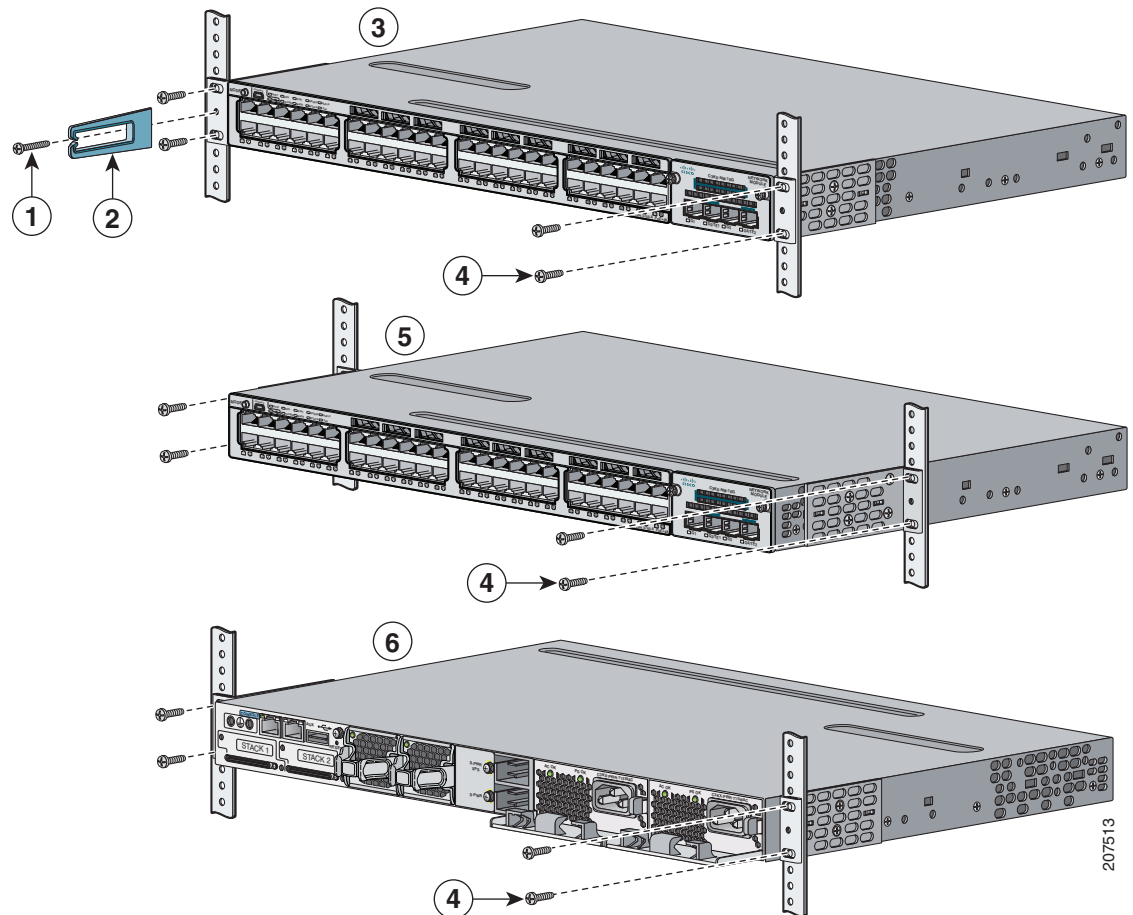

1	Black Phillips machine screw	4	Number-12 Phillips machine screws
2	Cable guide	5	Mid-mounting position
3	Front-mounting position	6	Rear-mounting position

Securing the AC Power Cord (Optional)

Make a loop in the power cord and thread it through the power cord retainer. Connect the power cord to the power supply.

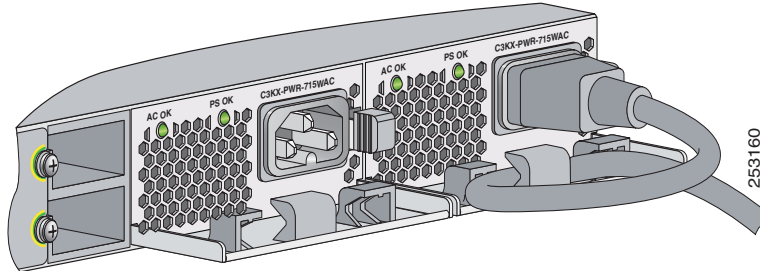

Connecting the StackWise Cables (Catalyst 3750-X Switch)

Always use a Cisco-approved StackWise cable to connect the switches.

Connect the cable to the StackWise port on the switch rear panel. Use the window in the StackWise cable to align the connector. Use a ratcheting torque screwdriver to tighten the retainer screws to 5-inch pound of torque. Connect the other end of the cable to the port of the other switch, and tighten the retainer screws to 5-inch pound of torque. Avoid overtightening the screws.

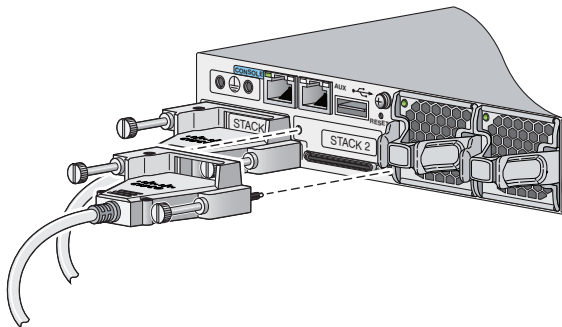

Caution

Removing and installing the StackWise cable can shorten its life. Do not remove and insert the cable more often than is necessary.

StackWise Cabling Configurations

This illustration shows the recommended stack configuration with connections using 0.5-meter StackWise cables.

For more configuration examples, see the hardware installation guide on Cisco.com.

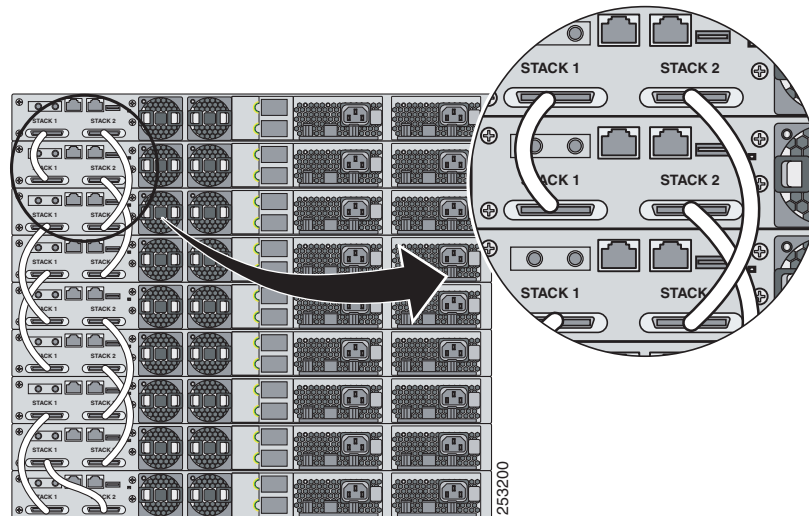

Connecting the StackPower Cables (Catalyst 3750-X Switch)

Always use a Cisco-approved StackPower cable to connect the switches.



Note

The Catalyst 3750-X S-PWR ports accept either the yellow or the green end of the StackPower cable.

Align the connector and connect the StackPower cable to the S-PWR port on the switch rear panel and finger-tighten the screw. Connect the other end of the cable to the port on the other switch and finger-tighten the screw. Avoid overtightening the screws.

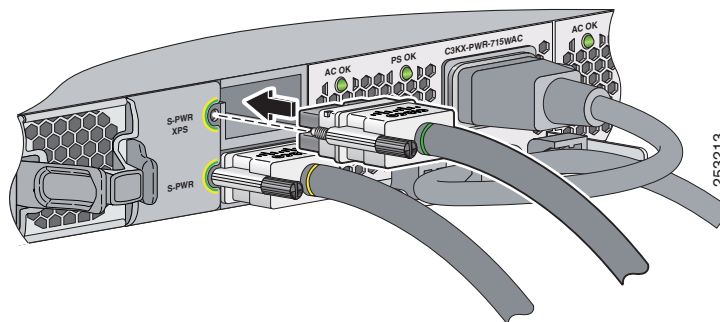

Caution

Removing and installing the StackPower cable can shorten its life. Do not remove and insert the cable more often than is necessary.

StackPower Cabling Configurations

You can configure a StackPower stack of up to four switches for either power-sharing or redundancy. This illustration shows the recommended stack configuration with connections using 0.305-meter StackPower cables.

For more examples, see the hardware installation guide on Cisco.com.

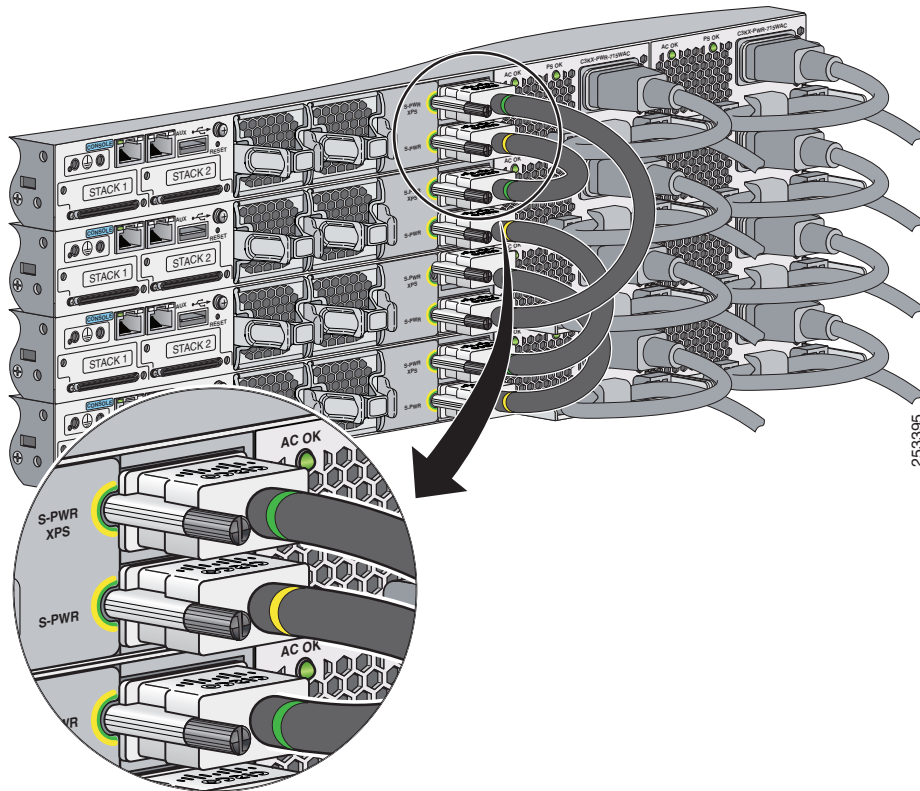

Installing the Network Module (Optional)

The switch accepts a hot-swappable network expansion module that provides SFP (1 Gigabit) and SFP+ (10 Gigabit) uplink ports.



Note

You need a number-2 Phillips screwdriver to install the network module.

Step 1 Loosen the captive screws, and remove the blank network module cover.

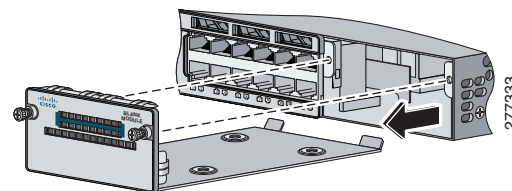

Step 2 Slide the network module into the opening until the back of the module faceplate is flush with the switch faceplate. Tighten the captive screws.

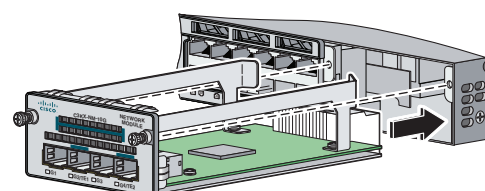

Connecting the Switch Ports

10/100/1000 Ports

When you connect to servers, workstations, IP phones, wireless access points, and routers, use a straight-through, twisted four-pair, Category 5 cable in a 10/100/1000 port. Use a crossover, twisted four-pair, Category 5 cable when you connect to other switches, hubs, or repeaters. Connect the other cable end to an RJ-45 port on the other device.

Depending upon the installed power supply, the 10/100/1000 ports support Power over Ethernet (PoE) and PoE+.

PoE inline power supports devices compliant with IEEE 802.3af, as well as prestandard Cisco IP Phones and Cisco Aironet Access Points. Each port can deliver up to 15.4 W of power.

PoE+ inline power supports devices compliant with IEEE 802.3at, delivering up to 30 W to all switch ports.

See the hardware installation guide on Cisco.com.



Note

The automatic medium-dependent interface crossover (auto-MDIX) feature is enabled by default. The switch detects the required cable type for copper Ethernet connections and configures the interfaces. You can use either a crossover or a straight-through cable for connections to a copper 10/100/1000 module port on the switch, regardless of the type of connected device.

SFP-Module Ports

Step 1 Hold the SFP module on the sides, and insert it into the switch slot until you feel the connector snap into place.

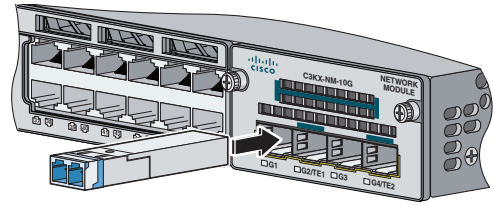

Step 2 Connect an appropriate cable to the module port.

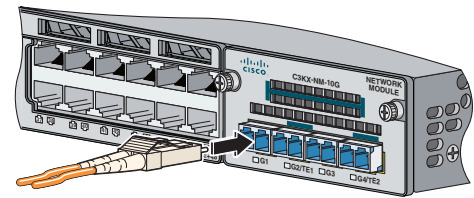

Step 3 Connect the other cable end to the other device.

Use only Cisco SFP modules with the switch. For a list of supported modules, see the release notes on Cisco.com. For detailed instructions on installing, removing, and connecting to SFP modules, see the SFP module documentation.

Verify Port Connectivity

After you connect a device to the switch port, the port LED turns amber for about 30 seconds while the switch establishes a link. The LED turns green when the switch and the attached device have a link. If the LED is off, the device might not be turned on, there might be a cable problem, or there might be a problem with the adapter installed in the device.

Troubleshooting

Express Setup

If Express Setup does not run, or if the Express Setup page does not appear in your browser:

- Did you verify that POST ran successfully before starting Express Setup?

If not, make sure that only the SYST and STAT LEDs are green before you press the Mode button to enter the Express Setup mode.

POST errors are usually fatal. Contact your Cisco technical support representative if your switch fails POST.
- Did you press the Mode button while the switch was still running POST?

If yes, wait until POST completes. Power cycle the switch. Wait until POST completes. Confirm that the SYST and STAT LEDs are green. Press the Mode button to enter Express Setup mode.
- Did you try to continue without confirming that the switch was in Express Setup mode?

Verify that all LEDs next to the Mode button are green. (The XPS LED stays off.) If not, press and hold the Mode button to enter Express Setup mode.
- Does your PC have a static IP address?

If yes, change your PC settings to temporarily use DHCP before connecting it to the switch.
- Did you connect the Ethernet cable to the console port instead of a 10/100/1000 Ethernet port or the management port on the switch?

If yes, disconnect the cable from the console port. Connect the cable to an Ethernet port on the switch. Wait 30 seconds before you enter **10.0.0.1** in the browser.
- Did you wait 30 seconds after you connected the switch and the PC before you entered the IP address in your browser?

If not, wait 30 seconds, re-enter **10.0.0.1** in the browser, and press Enter.
- Did you enter the wrong address in the browser, or is there an error message?

If yes, re-enter **10.0.0.1** in the browser, and press Enter.

Resetting the Switch to the Default Settings

**Caution**

Resetting the switch deletes the configuration and restarts the switch.

1. Press and hold the Mode button. The switch LEDs begin blinking after about 3 seconds.
2. Continue holding down the Mode button. The LEDs stop blinking after 7 more seconds, and then the switch restarts.

The switch now behaves like an unconfigured switch. You can enter the switch IP information by using Express Setup as described in the [“Running Express Setup” section on page 3](#).

Accessing Help Online

First look for a solution to your problem in the troubleshooting section of the hardware installation guide or the software configuration guide on Cisco.com. You can also access the Cisco Technical Support and Documentation website for a list of known hardware problems and extensive troubleshooting documentation.

Obtaining Documentation and Submitting a Service Request

For information on obtaining documentation, submitting a service request, and gathering additional information, see the monthly *What's New in Cisco Product Documentation*, which also lists all new and revised Cisco technical documentation, at:

<http://www.cisco.com/en/US/docs/general/whatsnew/whatsnew.html>

Subscribe to the *What's New in Cisco Product Documentation* as a Really Simple Syndication (RSS) feed and set content to be delivered directly to your desktop using a reader application. The RSS feeds are a free service and Cisco currently supports RSS Version 2.0.

For More Information

- *Catalyst 3750-X and 3560-X Switch Getting Started Guide*
- *Catalyst 3750-X and 3560-X Switch Hardware Installation Guide*
- *Regulatory Compliance and Safety Information for the Catalyst 3750-X and 3560-X Switch*
- *Installation Notes for the Catalyst 3750-X and Catalyst 3560-X Switch Power Supply Modules*
- *Installation Notes for the Catalyst 3750-X and 3560-X Switch Fan Module*
- *Installation Notes for the Catalyst 3750-X and 3560-X Switch Network Modules*
- *Release Notes for the Catalyst 3750-X and 3560-X Switch*
- *Catalyst 3750-X and 3560-X Switch Software Configuration Guide*
- *Catalyst 3750-X and 3560-X Switch Command Reference*
- *Catalyst 3750-X, 3750-E, 3560-X, and 3560-E Switch System Message Guide*
- *Cisco IOS Software Installation Document*
- Information about Cisco SFP and SFP+ modules is available from this Cisco.com site:
http://www.cisco.com/en/US/products/hw/modules/ps5455/prod_installation_guides_list.html
- SFP compatibility matrix documents are available from this Cisco.com site:
http://www.cisco.com/en/US/products/hw/modules/ps5455/products_device_support_tables_list.html

Cisco and the Cisco logo are trademarks or registered trademarks of Cisco and/or its affiliates in the U.S. and other countries. To view a list of Cisco trademarks, go to this URL: www.cisco.com/go/trademarks. Third-party trademarks mentioned are the property of their respective owners. The use of the word partner does not imply a partnership relationship between Cisco and any other company. (1110R)

Any Internet Protocol (IP) addresses used in this document are not intended to be actual addresses. Any examples, command display output, and figures included in the document are shown for illustrative purposes only. Any use of actual IP addresses in illustrative content is unintentional and coincidental.

© 2010 Cisco Systems, Inc. All rights reserved.