



## CHAPTER 5

# Managing External Resources

---

Revised: August 10, 2011, OL-25015-01

## Introduction

This chapter tells you how to manage external resources provisioned on the BTS using administrative (ADM) commands. External resources have two service states:

- Administrative—State the BTS user provisions for the resource link
- Operational—Physical condition of the resource link or the resource)

The two types of service states are independent of each other, for example:

A user places an MGW link in-service; its administrative state is ADMIN\_INS. But that link between the BTS and MGW is lost. The MGW link's operational state is MGW\_STATUS\_DOWN. A query of the MGW returns both the administrative state and operational state.

## Viewing BTS System-Wide Status

BTSSTAT runs on any BTS host. Any valid UNIX user can enter `btsstat` from a UNIX shell to initiate it. This command returns the following for all BTS components:

- Component id
- Side
- Host name
- Version
- Replication status
- Redundancy status

To run BTSSTAT from a non-BTS host, the configuration file needs the information in following table. BTSSTAT ignores all other lines in the file.

**Table 5-1 Using BTSSTAT**

<b>Task</b>	<b>Sample Command</b>
Viewing status of entire BTS system (including components not on the same host)	<code>btsstat</code>
Viewing status of specific components	CA <code>btsstat -caport</code>  FSAIN <code>btsstat -fsainport</code>  FSPTC <code>btsstat -fsptcport</code>  EMS <code>btsstat -emsport</code>  BDMS <code>btsstat -bdmsport</code>
Running BTSSTAT from a non-BTS host (requires an SSL connection to the BTS)	<code>btsstat -f my_cfg_file</code>  Specify BTS hosts in a configuration file: <ul style="list-style-type: none"> <li>• CA_SIDE_A_HN = prica11 CA_SIDE_B_HN = secca11</li> <li>• FSAIN_SIDE_A_HN = prica11 FSAIN_SIDE_B_HN = secca11</li> <li>• FSPTC_SIDE_A_HN = prica11 FSPTC_SIDE_B_HN = secca11</li> <li>• EMS_SIDE_A_HN = priems11 EMS_SIDE_B_HN = secems11</li> <li>• BDMS_SIDE_A_HN = priems11 BDMS_SIDE_B_HN = secems11</li> </ul>
Viewing BTS software version and installed patches	<code>nodestat</code>

# Managing Trunk Groups and Trunks

**Table 5-2** *Managing Trunk Groups*

Task	Sample Command
Viewing TG status	<pre>status trunk-grp id=2;</pre> <p>Possible operational states:</p> <ul style="list-style-type: none"> <li>• in-service</li> <li>• out of service</li> <li>• manually busy</li> <li>• operate in wait state, operate in standby state</li> <li>• restore session request normal, restore session request switchover, restore session request maintenance, restore session fail normal, restore session fail switchover, restore session fail maintenance, restore establish request normal, restore establish request switchover, restore establish request maintenance, restore establish fail normal, restore establish fail switchover, restore establish fail maintenance</li> <li>• in maintenance state</li> <li>• down session set fail soft normal, down session set fail hard normal, down session set fail soft maintenance, down session set fail hard maintenance, down establish request soft normal, down establish request hard normal, down establish request soft maintenance, down establish request hard maintenance, down establish request hard normal, down establish request soft maintenance, down establish request hard maintenance, down establish fail soft normal, down establish fail hard normal, down establish fail soft maintenance, down establish fail hard maintenance</li> <li>• delete graceful</li> <li>• request remove release, request remove session set</li> <li>• remove graceful in-service and maintenance state</li> <li>• DPC is inaccessible</li> </ul>
Viewing TGs with ISDN D channels	<pre>show isdn-dchan</pre>
Switching ISDN D channels	<pre>control isdn-dchan tgn-id=1;</pre> <p>This switches the active D channel to standby, and the standby D channel to active.</p>
Changing TGs states	<pre>control trunk-grp tgn-id=129; mode=forced; target-state=oos;</pre> <p><b>Note</b> Before bringing an ISDN trunk in-service, put the connected media gateway in-service, see <a href="#">Changing media gateways status</a>.</p>
Viewing trunk status	<pre>status trunk-termination tgn-id=2; cic=8;</pre>

Table 5-2 Managing Trunk Groups (continued)

Task	Sample Command
Resetting trunks	<pre>reset trunk-termination tgn-id=13; cic=1-6;</pre> <p>Resetting does the following:</p> <ul style="list-style-type: none"> <li>• Clears all manual and blocked states</li> <li>• Clears active/transient calls on a trunk termination, with the exception of SS7 trunk terminations.</li> <li>• Brings trunks INS</li> </ul>
Changing trunk states	<pre>control trunk-termination tgn-id=17; cic=1-23; target-state=ins; mode=forced;</pre> <pre>equip trunk-termination tgn-id=13; cic=all;</pre> <p>Changes trunks in UEQP to OOS</p> <pre>unequip subscriber-termination id=97_8@ipclab.cisco.com;</pre> <p>Changes OOS trunks to UEQP</p>
Forcing MAINT state	<p>SS7 trunks</p> <pre>control ss7-trunk-termination tgn-id=103; mode=forced; target-state=maint;</pre> <p><b>Note</b> Set COT on the terminating gateway or switch to perform these tests. Otherwise, the test or tests fail.</p> <p>ISDN trunks</p> <pre>control isdn-trunk-termination tgn-id=17; mode=forced; target-state=maint;</pre> <p>CAS trunks</p> <pre>control cas-trunk-termination tgn-id=64; mode=forced; target-state=maint;</pre> <p>Announcement trunks</p> <pre>control annc-trunk-termination tgn-id=13; mode=forced; target-state=maint;</pre>

**Table 5-2** *Managing Trunk Groups (continued)*

<b>Task</b>	<b>Sample Command</b>
Viewing test menus	SS7 trunks <code>diag ss7-trunk-termination test=&lt;TAB&gt;</code> <code>diag ss7-trunk-termination test=&lt;RETURN&gt;</code> ISDN trunks <code>diag isdn-trunk-termination test=&lt;TAB&gt;</code> <code>diag isdn-trunk-termination test=&lt;RETURN&gt;</code> CAS trunks <code>diag cas-trunk-termination test=&lt;TAB&gt;</code> <code>diag cas-trunk-termination test=&lt;RETURN&gt;</code> Announcement trunks <code>diag annc-trunk-termination test=&lt;TAB&gt;</code> <code>diag annc-trunk-termination test=&lt;RETURN&gt;</code>

Table 5-2 Managing Trunk Groups (continued)

Task	Sample Command
Testing trunks (place in MAINT state first)	<p>SS7 trunks</p> <pre>diag ss7-trunk-termination tgn-id=103; cic=13; test=1;</pre> <p>Test 1: SS7 MGCP Connectivity Test—tests if MGCP has access to the SS7 trunk termination</p> <p>Test 2: SS7 Termination Connection Test—tests if there is a path to the device (ping).</p> <p>Test 3: SS7 COT Test—tests the integrity of the SS7 Bearer Path.</p> <p>Test 4: SS7 CQM Test—queries the SS7 circuit (or group of circuits) status. A range of CICs can be specified (to a maximum of 24). Both remote and local trunk states are displayed in the results.</p> <p>Test 5: SS7 CVT Test—tests to ensure that each end of the circuit has sufficient and consistent information for using the circuit in call connections. CLLI names are included.</p> <p>Test 6: SS7 CIC Audit—returns status of CICs</p> <p>Test 0: ALL—performs tests 1 through 6.</p> <p>ISDN trunks</p> <pre>diag isdn-trunk-termination test=1; tgn-id=17; cic=1;</pre> <ol style="list-style-type: none"> <li>1. Tests if MGCP has access to the ISDN termination</li> <li>2. Tests if there is a path to the device (ping)</li> <li>3. Performs tests 1 and 2</li> </ol> <p>CAS trunks</p> <pre>diag cas-trunk-termination tgn-id=64;cic=1;test=1;</pre> <ol style="list-style-type: none"> <li>1. Tests if MGCP has access to the CAS termination</li> <li>2. Tests if there is a path to the device (ping)</li> <li>3. Performs tests 1 and 2</li> </ol> <p>Announcement trunks</p> <pre>diag annc-trunk-termination;test=1;tgn-id=13;cic=1</pre> <ol style="list-style-type: none"> <li>1. Tests if MGCP has access to the ANC termination</li> <li>2. Tests if there is a path to the device (ping)</li> <li>3. Performs tests 1 and 2</li> </ol>

Table 5-3 Valid Normal Trunk Termination States

State/Token	ADMIN-STATE	OPER-STATE	STATIC-STATE	DYNAMIC-STATE
UNEQP	UNEQP	ANY	UEQP	IDLE
MANUALLY OOS	OOS	ANY	LBLK	IDLE
MANUALLY MAIN	MAINT	IDLE	LBLK	IDLE

**Table 5-3** Valid Normal Trunk Termination States (continued)

State/Token	ADMIN-STATE	OPER-STATE	STATIC-STATE	DYNAMIC-STATE
IDLE	INS	IDLE	ACTV	IDLE
ACTIVE INCOMING	INS	IDLE	ACTV	IDLE
ACTIVE OUTGOING	INS	ACTIVE	ACTV	OBSY
TRANSIENT INCOMING	INS	ACTIVE	ACTV	IBY-TRNS
TRANSIENT OUTGOING	INS	BUSY	ACTV	OBSY-TRNS

If a TG or trunk command fails, it can return one of the following generic failure reasons, as well as ones specific to the command.

**Table 5-4** Understanding Trunk Group and Trunk Generic Command Responses

Command Entered	Command Response	Possible Conditions
<code>status</code> or <code>control</code>	Failure	<p>TG or trunk database was not found in shared memory.</p> <p>Component is already in the requested state.</p> <p>Graceful mode only. Appears when a command is executed and operation is INS going OSS or INS going MAINT.</p> <p>A required resource is not available.</p> <p>For ISDN</p> <ul style="list-style-type: none"> <li>- A trunk cannot be added unless both the MGW and TG are available.</li> <li>- A TG cannot be added unless the MGW is available, and vice versa.</li> </ul> <p>For SS7, CAS, Announcement</p> <ul style="list-style-type: none"> <li>- A trunk cannot be added unless both the MGW and TG are available.</li> <li>- A TG does not require the MGW to be available, and vice versa.</li> </ul> <p>An associated resource of the database cannot be found.</p> <p>An assigned resource is not valid (supported).</p>

**Table 5-4** Understanding Trunk Group and Trunk Generic Command Responses (continued)

Command Entered	Command Response	Possible Conditions
any	Failure	<ul style="list-style-type: none"> <li>• Found no failure</li> <li>• TG(s) cannot be found, trunk(s) cannot be found, no TG(s) found in trunking gateway, no trunk(s) found in TG</li> <li>• Fail while in termination table, fail while in TG table, fail while in trunk table, fail while looking to find trunk index, fail while getting TG administration state</li> <li>• Failed to allocate IPC message(s), failed to dispatch IPC message(s)</li> <li>• Operational state invalid, administration state invalid</li> <li>• Trunk(s) state change and pending</li> <li>• Found TG type invalid, found TG state invalid, found TG admin state not ready</li> <li>• Entity in desired state</li> <li>• Not allow trunk to reset</li> <li>• Change to out-of-service state required, change to request graceful mode error</li> <li>• Found entity unequipped in initial state</li> <li>• Operation not allowed because D Channel(s) is down</li> <li>• Found unknown failure reason(s)</li> </ul>



**Table 5-4 Understanding Trunk Group and Trunk Generic Command Responses (continued)**

Command Entered	Command Response	Possible Conditions
Trunk Termination commands	Failure	<ul style="list-style-type: none"> <li>• The transaction could not be executed due to a transient error, the endpoint is unknown, the endpoint is not ready, endpoint does not have enough resources available, a protocol error was detected, the command contained an unrecognized extension, the endpoint is restarting.</li> <li>• Invalid conn identifier, invalid call ID.</li> <li>• Unsupported mode or invalid mode, unsupported or unknown package.</li> <li>• Endpoint does not have a digit map, endpoint redirected to another Call Agent, endpoint malfunctioning, endpoint taken out of service.</li> <li>• No such event or signal.</li> <li>• Unknown action or illegal combination of actions.</li> <li>• Internal consistency in local connection options, unknown extensions in local connection options, unsupported values on local connection options.</li> <li>• Insufficient bandwidth.</li> <li>• Missing remote connection descriptor.</li> <li>• Incompatible protocol version.</li> <li>• Internal hardware failure.</li> <li>• CAS signaling protocol error.</li> <li>• Failure of a group of trunks.</li> <li>• Response too big.</li> <li>• Loss of lower connectivity.</li> <li>• No fault reason available.</li> </ul>

**Table 5-4 Understanding Trunk Group and Trunk Generic Command Responses (continued)**

Command Entered	Command Response	Possible Conditions
Trunk commands	Failure	<ul style="list-style-type: none"> <li>• NON-FAULTY—Not blocked, available for service.</li> <li>• MAINT-OOS—Trunk-termination is manually controlled OOS.</li> <li>• MAINT-BUSY—Trunk-termination is in maintenance state; controlled to MAINT.</li> <li>• TERM-FAULT—Bearer termination is in faulty condition.</li> <li>• SIGNALLING-FAULT—Signaling link (for example, SS7 link, or ISDN D channel) is faulty.</li> <li>• MAINT-BLOCK—Trunk-termination is manually controlled OOS (controlled mode=GRACE).</li> <li>• HARDWARE-BLOCK—Trunk-termination is manually controlled OOS (controlled mode=FORCED).</li> <li>• OUTGOING_RESTRICTED—The outgoing call is not allowed</li> <li>• DPC_INACCESSIBLE—The DPC is not accessible.</li> <li>• ACL_CONGESTION_LEVEL_1—Automatic Congestion Level (ACL) congestion is at level 1.</li> <li>• ACL_CONGESTION_LEVEL_2—ACL congestion is at level 2.</li> <li>• ACL_CONGESTION_LEVEL_3—ACL congestion is at level 2.</li> <li>• TFC_CONGESTION_LEVEL_1—Transfer Controlled (TFC) congestion is at level 1.</li> <li>• TFC_CONGESTION_LEVEL_2—TFC congestion is at level 2.</li> <li>• TFC_CONGESTION_LEVEL_3—TFC congestion is at level 3.</li> </ul>

**Table 5-4 Understanding Trunk Group and Trunk Generic Command Responses (continued)**

Command Entered	Command Response	Possible Conditions
SS7 trunk commands	Failure	<ul style="list-style-type: none"> <li>• ACT_LOC_INIT_RESET—Reset circuit at startup.</li> <li>• ACT_LOC_MML_RESET—Craft reset request.</li> <li>• ACT_LOC_QUERY—Circuit query.</li> <li>• ACT_LOC_UPU—Action to perform user part unavailable.</li> <li>• ACT_LOC_VALIDATE—Circuit validation.</li> <li>• ACT_LOC_COTTEST—COT test.</li> <li>• ACT_LOC_STOP—Action to stop the call.</li> <li>• BLK_LOC_UPU—Trunk is blocked because user part is unavailable.</li> <li>• DES_LOC_GRACE—Local hardware RSIP graceful.</li> <li>• DES_LOC_SIG—SS7 signaling fault (link fail).</li> <li>• DES_LOC_FORCE—Local hardware RSIP forced.</li> <li>• DES_LOC_MML—MML; also used for unsolicited blocks from MDL due to circuit query reservation (CQR).</li> <li>• DES_LOC_UPU—Trunk needs to be blocked because of user part unavailability.</li> <li>• JOB_PENDING—Ongoing job in progress.</li> <li>• JOB_REC—Job was received by the MDL component and is being processed.</li> <li>• OPER_ACTIVE—Trunk is available for calls.</li> <li>• REMOTE_GRACE—Trunk is blocked remotely because of a CLI command on the remote switch.</li> <li>• REMOTE_FORCE—Trunk is blocked remotely because of a hardware failure on the remote switch.</li> <li>• RESERVE_SPARE1—Reserved for future use.</li> <li>• RESERVE_SPARE2—Reserved for future use.</li> <li>• TERM_GRACE—Trunk is gracefully blocked because of an RSIP graceful from the MGW.</li> </ul>

# Managing Subscriber Terminations

**Table 5-5** *Managing Subscriber Terminations*

Task	Sample Command
Checking subscriber status	<pre>status subscriber-termination id=ubr204_1;</pre> <p>Possible states:</p> <ul style="list-style-type: none"> <li>• ADMIN-UEQP—Unequipped. <ul style="list-style-type: none"> <li>– Newly-provisioned subscriber terminations are UEQP</li> <li>– Place a subscriber termination in UEQP before deleting it</li> </ul> </li> <li>• ADMIN-INS—In-service</li> <li>• ADMIN-OOS—Out of service</li> <li>• ADMIN-MAINT—Maintenance Mode</li> <li>• ADMIN-OOS-PENDING—Transitioning to out of service</li> <li>• ADMIN-MAINT-PENDING—Transitioning to Maintenance Mode</li> </ul>
Checking subscriber status in detail	<pre>status subscriber-termination id=@ubr235; oper-state=FA;ISDN Administrative and Operational Maintenance States for a Trunking Gateway</pre> <p>For more information use one of the following for oper-state:</p> <ul style="list-style-type: none"> <li>• FA—Faulty</li> <li>• NF—Not faulty</li> <li>• IDLE—Termination idle</li> <li>• ACTIVE—Termination active</li> <li>• DOWN—Termination down</li> <li>• TERM-FA—Termination fault</li> <li>• TEMP-DOWN—Termination temporarily down</li> <li>• UNREACH—Termination unreachable</li> <li>• INT-MAINT—Termination internal maintenance</li> <li>• UEQP—Termination unequipped</li> <li>• ALL—All states, same as executing command without oper-state token</li> </ul>

Table 5-5 Managing Subscriber Terminations (continued)

Task	Sample Command
Changing subscriber termination states	<pre>control subscriber-termination id=*c3810_167; mode=forced; target-state=INS;</pre> <p>Possible states:</p> <ul style="list-style-type: none"> <li>• INS—In-service</li> <li>• OOS—Out of service</li> <li>• MNT—Maintenance mode</li> </ul> <pre>control subscriber-termination id=sub2-ctx2; mode=forced; target-state=maint;</pre> <p>Forces MAINT state, do this before testing</p> <pre>equip subscriber-termination id=97_8@ipclab.cisco.com;</pre> <p>Changes OOS subscriber terminations to UEQP</p> <pre>unequip subscriber-termination id=97_8@ipclab.cisco.com;</pre> <p>Changes INS subscriber terminations and puts them in UEQP, subscriber terminations state must be UEQP before you can delete them.</p>
Viewing test menus	<pre>diag subscriber-termination; test=&lt;TAB&gt;</pre> <pre>diag subscriber-termination; test=&lt;RETURN&gt;</pre>
Testing subscriber terminations (place subscriber terminations in MAINT state first)	<pre>diag subscriber-termination id=sub-ubr3-1@cisco.com; test=3; ring-duration=10;</pre> <p><b>Note</b> Ring-duration values are 0–999 (Default = 5). Maximum ring time is 30 seconds regardless of whether the duration is set higher than or equal to 31.</p> <ol style="list-style-type: none"> <li>1. Tests if MGCP has access to the termination</li> <li>2. Tests if there is a path to the device (ping)</li> <li>3. Tests if the subscriber can be rung</li> <li>4. Performs tests 1 through 3</li> </ol>

If a subscriber termination command fails, it can return one of the following generic failure reasons, as well as ones specific to the command.

**Table 5-6 Understanding Subscriber Command Responses**

<b>Command Entered</b>	<b>Command Response</b>	<b>Possible Conditions</b>
<code>status</code> or <code>control</code>	Failure	<ul style="list-style-type: none"> <li>• Subscriber database was not found in shared memory.</li> <li>• Component is already in the requested state.</li> <li>• Graceful mode only, this appears when a command is executed and operation is INS going OSS or INS going MAINT.</li> <li>• A required resource is not available. For example: The MGW for a subscriber is down, the subscriber cannot be added.</li> <li>• An associated resource of the database cannot be found.</li> <li>• An assigned resource is not valid (supported). For example, a subscriber is assigned to a PBX and the PBX is not supported.</li> </ul>

**Table 5-6 Understanding Subscriber Command Responses (continued)**

Command Entered	Command Response	Possible Conditions
Any	failure	<ul style="list-style-type: none"> <li>• Found no failure, subscriber category invalid, entity unequipped in initial state, unknown failure reason(s).</li> <li>• Subscriber(s) cannot be found, subscriber(s) state change and pending.</li> <li>• No termination(s) found in MGW.</li> <li>• Fail while in termination table.</li> <li>• Administration state invalid, operational state invalid.</li> <li>• Failed to allocate IPC message(s), failed to dispatch IPC message(s).</li> <li>• Entity in desired state.</li> <li>• Not allow subscriber to reset.</li> <li>• Change to out-of-service state required.</li> </ul>
Subscriber commands	Failure	<ul style="list-style-type: none"> <li>• The media gateway is down, unreachable, in a faulty state, transitioning to another state.</li> <li>• The transaction could not be executed because the endpoint is unknown, the endpoint is not ready, the endpoint does not have enough resources available, the endpoint is restarting, the command contained an unrecognized extension, the gateway is not equipped to detect one of the requested events, the gateway is not equipped to generate one of the requested signals, the gateway cannot send the specified announcement.</li> <li>• Invalid conn identifier, invalid call ID.</li> <li>• Unsupported mode or invalid mode, unsupported or unknown package.</li> <li>• Endpoint does not have a digit map, endpoint redirected to another Call Agent, endpoint malfunctioning, endpoint taken out of service.</li> <li>• No such event or signal.</li> <li>• Unknown action or illegal combination of actions.</li> <li>• Internal consistency in local connection options, unknown extensions in local connection options, unsupported values on local connection options.</li> <li>• Insufficient bandwidth.</li> <li>• Missing remote connection descriptor.</li> <li>• Incompatible protocol version.</li> <li>• Response too big.</li> <li>• Loss of lower connectivity.</li> <li>• No fault reason available.</li> </ul>

# Managing Gateways

**Table 5-7** Managing Gateways

Task	Sample Command
Viewing H.323 gateways	<pre>status h323-gw id=CHINA-1;</pre> <p>Possible RAS states:</p> <ul style="list-style-type: none"> <li>• CCH323_RAS_STATE_NONE—operational state is ADMIN OOS</li> <li>• CCH323_RAS_STATE_GRQ—Gatekeeper Discovery state</li> <li>• CCH323_RAS_STATE_RRQ—Gateway Registration state</li> <li>• CCH323_RAS_STATE_IDLE—ready for calls</li> <li>• CCH323_RAS_STATE_URQ—Un-registration state.</li> </ul>
Setting the state of H.323 gateways	<pre>control h323-gw id=CHINA_1; target-state=INS;</pre>
Viewing signaling gateway processes (SGPs)	<pre>status sgp id=sgp1;</pre>
Viewing media gateways status	<pre>status mgw id=c5300_197;</pre> <p>Possible states:</p> <ul style="list-style-type: none"> <li>• ADMIN-INS—In-service</li> <li>• ADMIN-OOS—Out of service</li> <li>• ADMIN-MAINT—Maintenance Mode</li> <li>• ADMIN-OOS-PENDING—Transitioning to out of service</li> <li>• ADMIN-MAINT-PENDING—Transitioning to Maintenance Mode</li> </ul>
Reporting all MTAs that use “best effort” (non DQoS) calls in the network having or not having a specific aggr id	<pre>report mgw id=%; oper-status=qos-best-effort; aggr-id=aggr1; start_row=1; limit=5;</pre> <p>Displays the output as CLI as the output-type has not been mentioned</p> <p>or</p> <pre>report mgw id=%; oper-status=qos-best-effort; aggr-id=%; output-type=xml; start_row=1; limit=5; output=report;</pre> <p>Displays the output in the specific format (CSV/XML) based on the output-type specified</p> <p><b>Note</b> The output displays only those mgws that use NCS variant.</p>



**Table 5-7** *Managing Gateways (continued)*

<b>Task</b>	<b>Sample Command</b>
Changing media gateway status	<pre>control mgw id=c5300_162; mode=forced; target-state=INS;</pre> <p>Modes can be forced or graceful. Forced tears down all calls immediately; graceful allows calls in progress to complete before teardown.</p> <p><b>Note</b> Rules for changing an MGW states are in <a href="#">Figure 5-1</a>.</p> <pre>control mgw id=c2421.65; mode=forced; target-state=maint;</pre> <p>Forces MAINT state, do this before testing</p>
Viewing media gateway test menus	<pre>diag mgw test= &lt;TAB&gt;</pre> <p>or</p> <pre>diag mgw test= &lt;RETURN&gt;</pre>
Testing media gateways (place gateways in MAINT state first)	<pre>diag mgw id=ubr-03; test=1;</pre>

If a gateway command fails, you might receive one of the following generic failure reasons, or one specific to the command.

**Table 5-8 Understanding Gateway Command Responses**

Command Entered	Command Response	Possible Conditions
<code>status</code> or <code>control</code>	Failure	<ul style="list-style-type: none"> <li>Media gateway database was not found in shared memory.</li> <li>Component is already in the requested state.</li> <li>Graceful mode only. Appears when a command is executed and operation is INS going OSS or INS going MAINT.</li> <li>A required resource is not available.</li> <li>An associated resource of the database cannot be found.</li> <li>An assigned resource is not valid (supported).</li> </ul>
any	Failure	<ul style="list-style-type: none"> <li>Found no failure.</li> <li>MGW(s) cannot be found, no termination(s) found in MGW, MGW(s) state change and pending, found MGW admin state not ready.</li> <li>No TG(s) found in trunking gateway.</li> <li>Fail while getting MGW administration state, fail while looking for MGW index.</li> <li>Administration state invalid.</li> <li>Failed to allocate IPC message(s), failed to dispatch IPC message(s).</li> <li>Operational state invalid.</li> <li>Subscriber(s) state change and pending.</li> <li>Trunk(s) state change and pending.</li> <li>Found subscriber category invalid.</li> <li>Entity in desired state.</li> <li>Change to out-of-service state required.</li> <li>Change to request graceful mode error.</li> <li>Found entity unequipped in initial state.</li> <li>The H.323 Gateway was not found in DBM.</li> <li>Found unknown failure reason(s).</li> </ul>

## Managing Other External Resources

**Table 5-9 Managing External Resources**

Task	Sample Command
Viewing SIP phones	<code>status sip-reg-contact aor-id=4695551885@SYS44CA146.boston3.com;</code>
Viewing aggregation router status	<code>status aggr id=CMTS1</code>

**Table 5-9** *Managing External Resources (continued)*

<b>Task</b>	<b>Sample Command</b>
Shows all CMTS (Aggr-ID) that are not referred by any Subnet.	<code>report aggr subnet=NONE;</code>
Viewing destination point codes (DPCs) status for availability and congestion	<code>status dpc id=dpc1;</code>
Viewing Stream Control Transmission Protocol (SCTP) associations	<code>status sctp-assoc id=sctpassoc1;</code>
Taking an SCTP association OOS	<code>control sctp-assoc id=sctpassoc1; target-state=INS; mode=FORCED;</code>  Modes can be forced or graceful. Forced tears down all calls immediately; graceful allows calls in progress to complete before teardown.
Viewing subsystems	<code>show subsystem;</code>
Viewing subsystems status	<code>status subsystem id=LNP_SSN; opc_id=opc;</code>
Changing subsystem status	<code>control subsystem id=LNP_SSN; opc_id=opc; target-state=OOS; mode=FORCED;</code>
Viewing CA/FS status	<code>show sup-config</code>
Changing CA/FS status refresh rate	<code>change sup-config type= refresh-rate; value=600</code>
Changing NTP servers	<ol style="list-style-type: none"> <li>1. Modify 'server' line(s) in /etc/ntp.conf.</li> <li>2. Modify 'NTP_SERVERS' in /etc/opticall.cfg</li> <li>3. Restart daemon:  <pre> /etc/init.d/xntp stop /etc/init.d/xntp start </pre> </li> <li>4. Verify configuration change:  <pre> /opt/BTSxntp/bin/ntpq -c peers" </pre> </li> </ol>

Table 5-9 Managing External Resources (continued)

Task	Sample Command
Ensuring billing server receives Call Detail Blocks (CDBs)	<ol style="list-style-type: none"> <li>1. On both the primary and secondary EMS enter: <code>CLI&gt;show billing-acct-addr</code></li> <li>2. Note the polling interval.</li> <li>3. Log in to the billing server.</li> <li>4. Ensure it receives billing files every XX minutes from the BTS, where XX = polling interval.</li> </ol>
Clearing billing directory	<p> <b>Caution</b> Remove only transferred or secondary files. Never remove primary files, you need these to collect revenue.</p> <ol style="list-style-type: none"> <li>1. Check the default format secondary files:   <code>&lt;billing-file-prefix&gt;-&lt;call-agent-id&gt;-(0/1){+/-}HHMMSS- -yyyymmdd-hhmmss-&lt;sequence-number&gt;-&lt;S&gt;</code>             where <b>s</b>=secondary state</li> <li>2. Check the PacketCable-specific format secondary files:   <code>&lt;billing-file-prefix&gt;_yyyymmddhhmmss_&lt;priority&gt;_&lt;1&gt;_&lt;c ms-id&gt;_&lt;sequence-number&gt;.ascii[.tmp]</code>             where <b>1</b>=secondary record-type</li> <li>3. On the secondary EMS enter <code>&lt;hostname&gt;#df -k</code></li> <li>4. Ensure the /opt directory is not more than 70% full.             If the /opt directory is &gt;70% full, remove obsolete scripting files and other user-generated files. Also remove obsolete files from the backup directory. For help call Cisco TAC.</li> </ol>

## Learning External Resource Dependencies

Table 5-10 RGW and Subscriber Termination States

RGW State	Allowed Subscriber Termination States
OOS	<ul style="list-style-type: none"> <li>• OOS</li> <li>• UEQP</li> </ul>

**Table 5-10** *RGW and Subscriber Termination States (continued)*

<b>RGW State</b>	<b>Allowed Subscriber Termination States</b>
INS	<ul style="list-style-type: none"> <li>• OOS</li> <li>• MAINT</li> <li>• INS</li> <li>• UEQP</li> </ul>
MAINT	<ul style="list-style-type: none"> <li>• OOS</li> <li>• MAINT</li> <li>• UEQP</li> </ul>

**Table 5-11** *ISDN TGW/TG State Relationships*

<b>TGW State</b>	<b>Allowed TG States</b>
INS	<ul style="list-style-type: none"> <li>• OOS</li> <li>• MAINT</li> <li>• INS</li> </ul>
MAINT	<ul style="list-style-type: none"> <li>• OOS</li> <li>• MAINT</li> </ul>

This table lists the administrative states BTS returns.

**Table 5-12** *Returnable Administrative States*

<b>State</b>	<b>Definition</b>
ADMIN-INS	In service.
ADMIN-OOS	Out of service.
ADMIN-MAINT	Maintenance Mode.
ADMIN-OOS-Pending	Transitioning to out of service.
ADMIN-MAINT-Pending	Transitioning to Maintenance Mode.
ACL	Congestion is at level 1
ACL	Congestion is at level 2
ACL	Congestion is at level 3
TFC	Congestion is at level 1
TFC	Congestion is at level 2
TFC	Congestion is at level 3

**Table 5-13 ISDN TGW/TG State Relationships**

TGW State	Allowed TG States	Allowed Trunk States
INS	<ul style="list-style-type: none"> <li>• OOS</li> <li>• MAINT</li> <li>• INS</li> </ul>	<ul style="list-style-type: none"> <li>• UEQP OOS</li> <li>• UEQP OSS, MAINT</li> <li>• UEQP OOS, MAINT, INS</li> </ul>
MAINT	<ul style="list-style-type: none"> <li>• OOS</li> <li>• MAINT</li> </ul>	<ul style="list-style-type: none"> <li>• UEQP OOS</li> <li>• UEQP OSS, MAINT</li> </ul>

**Table 5-14 Valid Normal Trunk Termination States**

State/Token	ADMIN-STATE	OPER-STATE	STATIC-STATE	DYNAMIC-STATE
UNEQP	UNEQP	ANY	UEQP	IDLE
MANUALLY OOS	OOS	ANY	LBLK	IDLE
MANUALLY MAIN	MAINT	IDLE	LBLK	IDLE
IDLE	INS	IDLE	ACTV	IDLE
ACTIVE INCOMING	INS	IDLE	ACTV	IDLE
ACTIVE OUTGOING	INS	ACTIVE	ACTV	OBSY
TRANSIENT INCOMING	INS	ACTIVE	ACTV	IBY-TRNS
TRANSIENT OUTGOING	INS	BUSY	ACTV	OBSY-TRNS

**Note**

If a call termination attempt is made on a termination for which gateway is unreachable, the termination status will be updated as unreachable even if MGW keepalive is disabled.

**Table 5-15 Returnable Operational States**

State	Definition
UNKNOWN	<ul style="list-style-type: none"> <li>• The termination is not being audited for connectivity.</li> <li>• Capabilities, termination, and connection are not being synchronized with the termination.</li> <li>• When KEEPALIVE-METHOD=NONE in MGW-PROFILE, the termination status is UNKNOWN even if the transaction becomes UNREACHABLE.</li> <li>• Newly-provisioned terminations are in this state.</li> </ul>
ACTIVE	<ul style="list-style-type: none"> <li>• The termination is being audited for connectivity.</li> <li>• Capabilities, termination, and connection are being synchronized with the termination.</li> </ul>

Table 5-15 Returnable Operational States (continued)

State	Definition
UNREACHABLE	<ul style="list-style-type: none"> <li>The termination is unreachable.</li> <li>This occurs when MGW KEEPALIVE declares an MGW unreachable.</li> <li>This changes to ACTIVE when MGW KEEPALIVE detects an MGW is reachable or any termination previously UNREACHABLE starts sending MGCP messages (NTFY, RSIP).</li> </ul>
FAULTY	<ul style="list-style-type: none"> <li>The termination returned a permanent error code, making it unusable for future calls.</li> </ul> <p> <b>Note</b> The error code may occur only in certain circumstances and re-audit/auto-recovery may succeed. This does not mean the termination recovered from that condition.</p> <ul style="list-style-type: none"> <li>The flag MGCP-MAX-FAULT-COUNT controls how many times BTS tries to recover the fault (performing re-audit/auto-recovery) before putting it in this state.</li> </ul>
MTRANS	<ul style="list-style-type: none"> <li>Maintenance Transient, the termination is in the middle of an audit/re-audit/auto-recovery.</li> <li>This state may go along with other states (MTRANS-UNREACH).</li> </ul>
IDLE	The termination is not involved in transient/active call
BUSY	<ul style="list-style-type: none"> <li>The termination is involved in Active/Transient call.</li> <li>This state may go along with CTRANS state.</li> </ul>
CTTRANS	<ul style="list-style-type: none"> <li>Call Transient, the termination is involved in a Transient call.</li> <li>This state always goes with BUSY.</li> </ul>
RESERVED	The termination is reserved for a call during Busy Line Verification
SERV_EFFC_TEST	The termination is in a Service Effecting Network loopback or Network Continuity test.
DOWN	This occurs when the MGW sends an RSIP down (graceful) message.

Source Token

Figure 5-1 Administrative and Operational Maintenance States for MGW

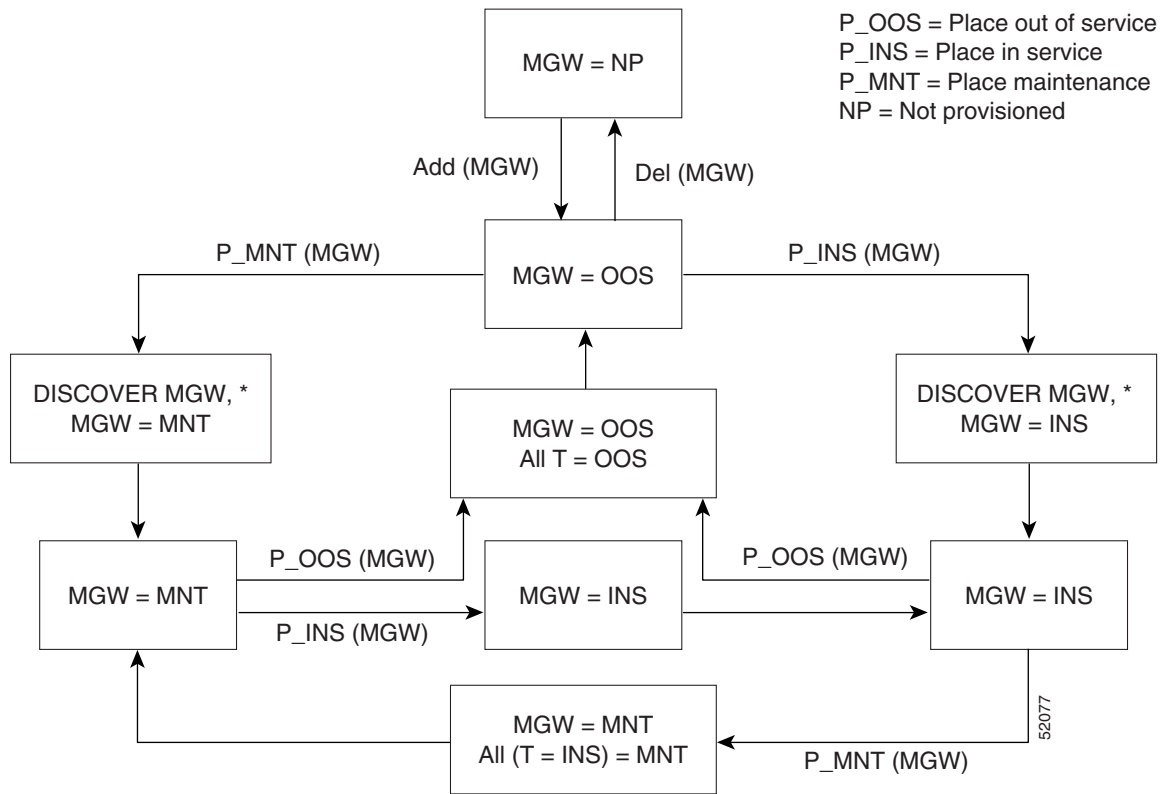

P\_OOS = Place out of service  
 P\_INS = Place in service  
 P\_MNT = Place maintenance  
 NP = Not provisioned

\* "Discover" means to establish MGCP communication with MGW



Figure 5-2 Administrative and Operational Maintenance States for Residential Gateways

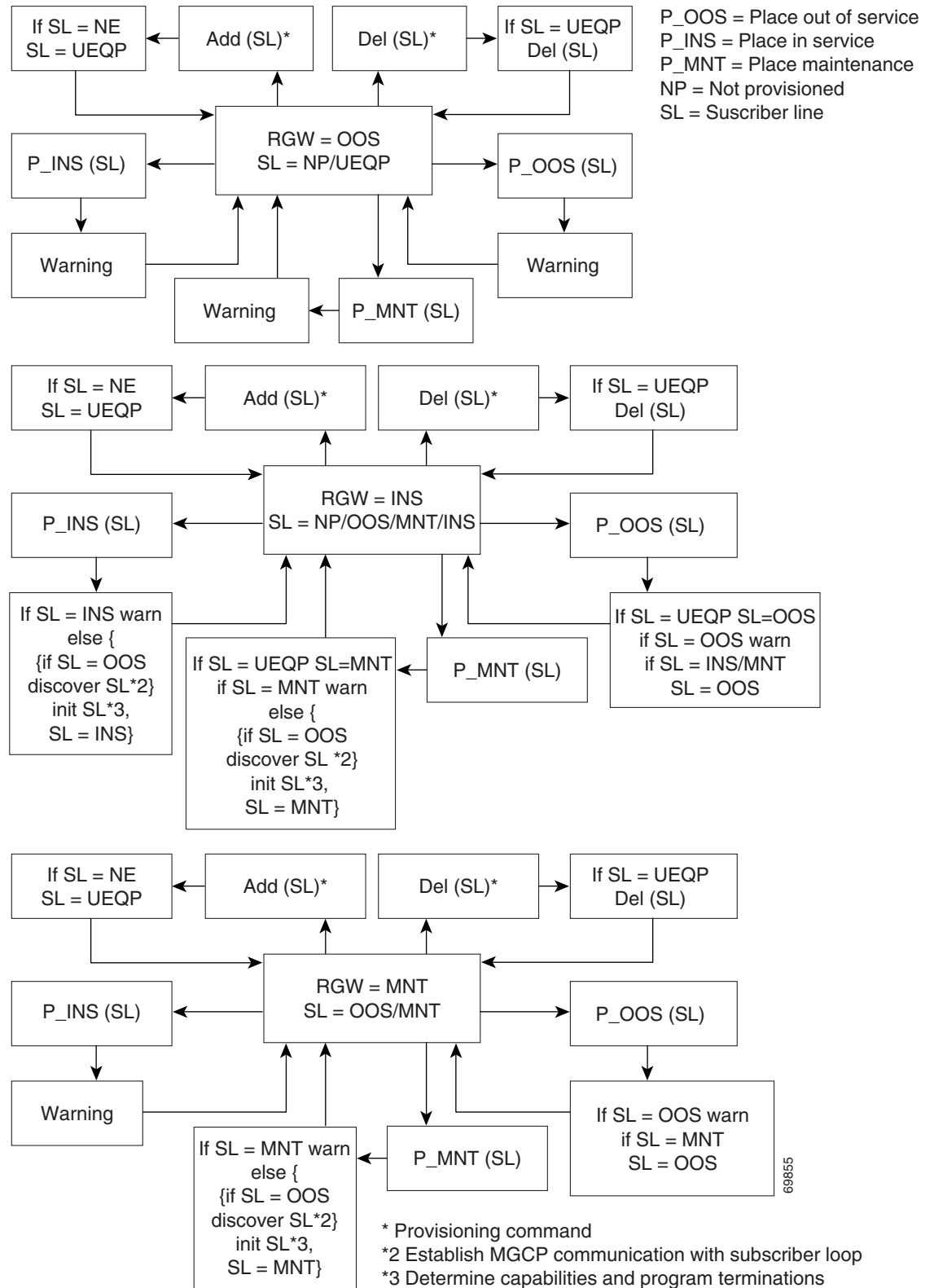
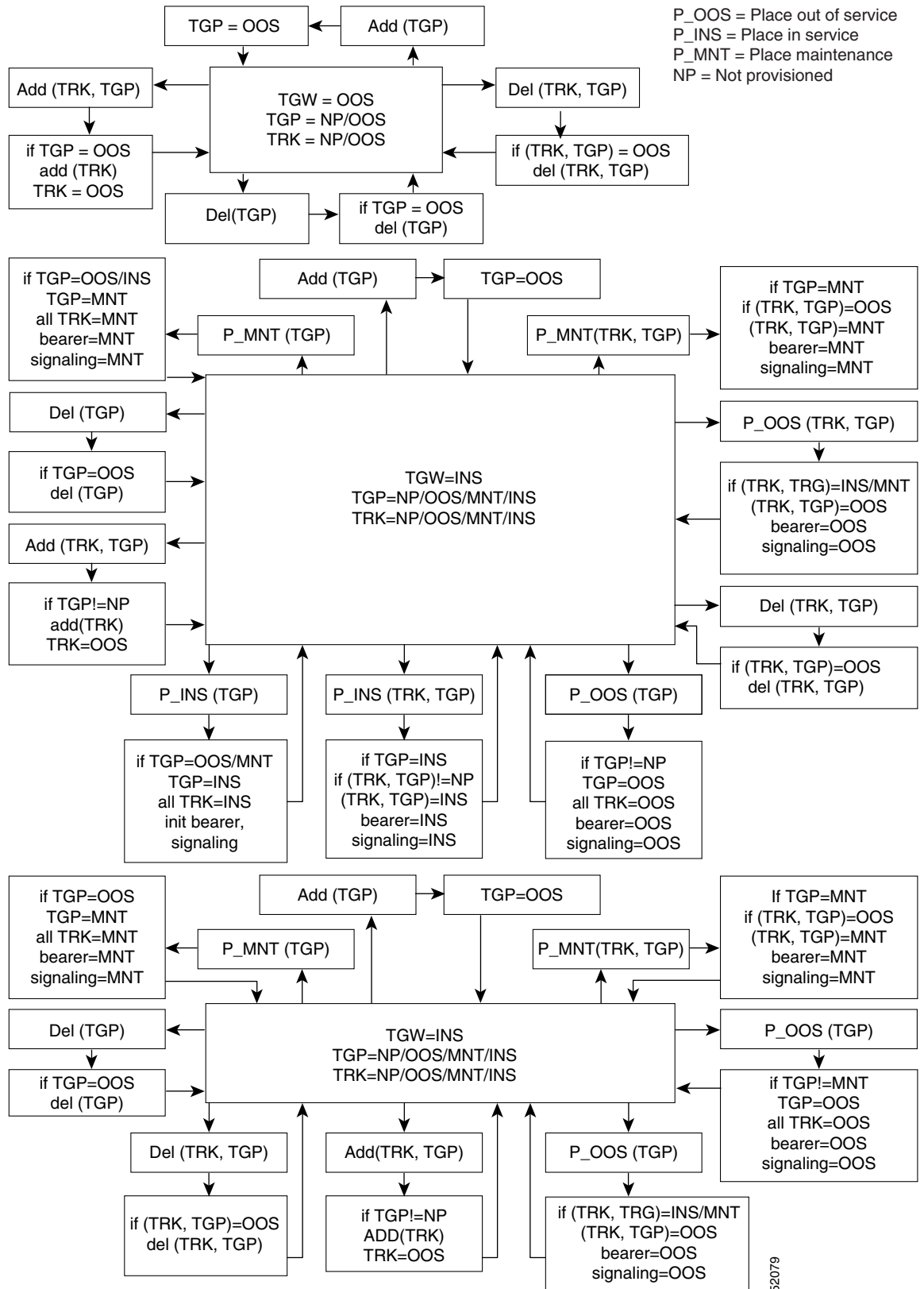
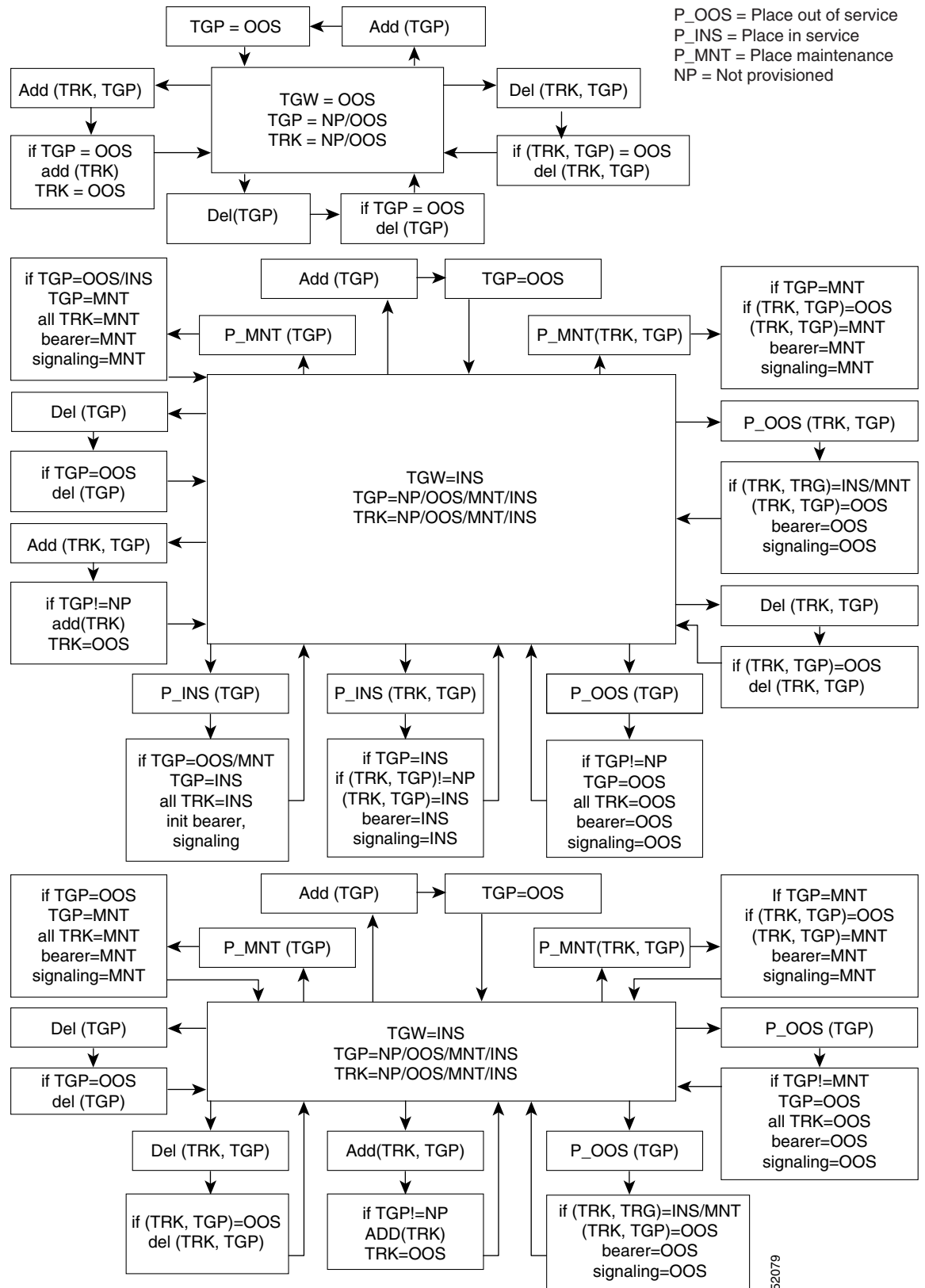

Figure 5-3 ISDN Administrative and Operational Maintenance States for a Trunking Gateway



52079



# GigE Support

The purpose of implementing the GigE Support Feature provisioning is to increase the bandwidth between the network switches and the Cisco BTS 10200 from 100 Mbps to 1000 Mbps.

This section describes the steps needed to enable GigE support on the UNIX hosts of the Cisco BTS 10200 Softswitch. Use this procedure only after you upgrade to Cisco BTS 10200 Release 6.0(1) or later.

**Caution**

This is not an upgrade procedure. Performing the steps in this procedure will bring the Cisco BTS 10200 down on one side with temporary loss of redundancy. Do not start this procedure unless you have authorization from your supervisor. If you have questions, contact Cisco Technical Assistance Center (TAC).

**Caution**

Perform this procedure on one UNIX host at a time.

**Caution**

This procedure should be executed by a person very familiar with the operation and administration of the Cisco BTS 10200 and 29xx switches as well as the network and cabling of the Cisco BTS 10200.

## Prerequisites

1. The Cisco BTS 10200 Softswitch Release 6.0(1) must already be installed.
2. The BTS 10200 UNIX host must have network interfaces capable of running at GigE speed (1000 Mbps).

## Provisioning the GigE Interface

For each host in Cisco BTS 10200, perform the following steps:

- Step 1** Ensure that the targeted Cisco BTS 10200 applications are operating in standby mode. These applications include the Call Agent (CA), the Feature Server for POTS, Tandem, and Centrex services (FSPTC), the Feature Server for AIN services (FSAIN), the Element Management System (EMS), and the Bulk Data Management System (BDMS). If necessary, perform a switchover to ensure this is the case.
- Step 2** Use the **platform stop all** command to stop the targeted Cisco BTS 10200 applications running on the UNIX host.
- Step 3** Identify and note the Ethernet ports on the 29xx switches that connect to the Cisco BTS 10200 UNIX host.
- Step 4** Modify the configuration of the switch ports connected to the Cisco BTS 10200 UNIX host to auto negotiate. To do so, first log in to the 29xx switch through console access, change to the switch port, and modify the speed and duplex mode settings on each port using the following commands:

```
no speed 100
no duplex full
```

```
shut
no shut
```

- Step 5** Save the switch configuration.
- Step 6** Reboot the Cisco BTS 10200 host using the **shutdown -g0 -y -i6** command. We recommend that you execute the **shutdown** command using the console port to avoid loss of connectivity during the reboot. After the reboot, all the targeted Cisco BTS 10200 applications should automatically restart and go into standby state.
- Step 7** Verify interface speed and duplex mode by executing the following command on the host:

```
dladm show-dev
```

Example output:

```
ca102> dladm show-dev
bge0 link: up speed: 1000 Mbps duplex: full
bge1 link: up speed: 1000 Mbps duplex: full
bge2 link: up speed: 1000 Mbps duplex: full
bge3 link: up speed: 1000 Mbps duplex: full
```

- Step 8** Repeat for the other UNIX hosts in the Cisco BTS 10200 system.
-

