



## Adding a Secondary Master PIMG Unit

Because the master PIMG unit processes all call information and MWI requests for the system, the integration loses important functionality if the master PIMG unit stops working. If you want to minimize this risk, you can add a secondary master PIMG unit to process call information and MWI requests when the primary master PIMG unit is no longer functioning.

During normal operation, the primary master PIMG unit is connected to power and is functioning, while the secondary master PIMG unit is not connected to power and is not functioning. To activate the secondary master PIMG unit, you must disconnect power to the primary master PIMG unit, then connect power to the secondary master PIMG unit.

The following task list describes the process for adding a secondary master PIMG unit.

- [Adding a Secondary Master PIMG Unit, on page 1](#)

## Adding a Secondary Master PIMG Unit

Because the master PIMG unit processes all call information and MWI requests for the system, the integration loses important functionality if the master PIMG unit stops working. If you want to minimize this risk, you can add a secondary master PIMG unit to process call information and MWI requests when the primary master PIMG unit is no longer functioning.

During normal operation, the primary master PIMG unit is connected to power and is functioning, while the secondary master PIMG unit is not connected to power and is not functioning. To activate the secondary master PIMG unit, you must disconnect power to the primary master PIMG unit, then connect power to the secondary master PIMG unit.

The following task list describes the process for adding a secondary master PIMG unit.

### Task List to Add a Secondary Master PIMG Unit

Use the following task list to add a secondary master PIMG unit.

1. Set up the analog voice line connections to the master PIMG units. See the [Analog Voice Line Connections for the Master PIMG Units](#).
2. Set up the serial data cable connections to the master PIMG units. See the [Serial Data Cable Connections for the Master PIMG Units](#).
3. Configure the secondary master PIMG unit. See the [Configuring the Secondary Master PIMG Unit](#).

## Analog Voice Line Connections for the Master PIMG Units

Circuit-switched phone systems typically have 25-pair or 32-pair cables to provide analog voice connections. It is common that the cable is broken into individual lines that may attach to a punchdown cross-connect block (for example, 66-Type), or the cable may terminate with RJ-11 or RJ-14 connectors to accept analog voice lines.

A punchdown cross-connect block or line splitters may be used to split the analog lines. It is possible to use these devices in combination to manage and split the lines.



**Note** No devices other than those described in this appendix should be connected to the analog voice lines for any voice messaging port on the master PIMG units. Otherwise, the ring equivalency number (REN) may be exceeded and the primary and secondary servers may not receive sufficient ring current to answer calls.

### Requirements

The following components are required for common configurations:

- Two or three analog voice patch cables for each port on the phone system.
- The applicable device to split the analog lines:
  - One or more punchdown cross-connect blocks (for example, 66-Type), installed and ready to accept lines.
  - One line splitter for every one or two ports on the phone system. The line splitter accepts both RJ-11 and RJ-14 connectors.
- The applicable connectors (RJ-11 and/or RJ-14) for the analog voice lines. Figure A-1 shows the pinout for the RJ-11 connector, and Figure A-2 shows the pinout for the RJ-14 connector.

**Figure 1: Figure A-1 RJ-11 Connector Pinout**

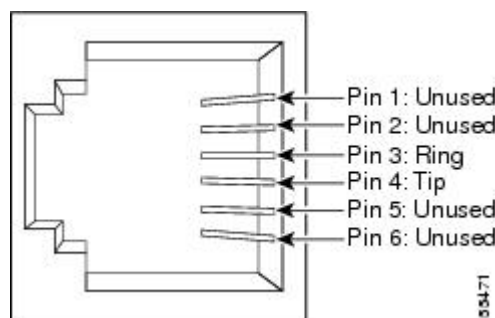
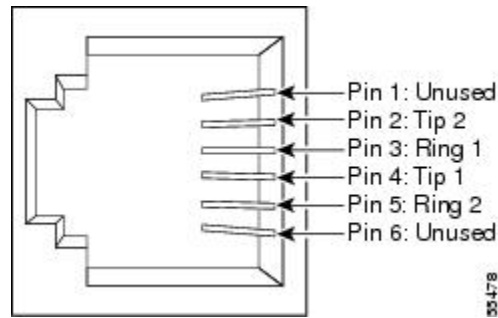

Figure 2: Figure A-2 RJ-14 Connector Pinout



## Connections Using RJ-11 Connectors

The following figures illustrate common configurations:

- Figure A-3 shows the connections between a phone system and the primary and secondary master PIMG units, through a punchdown cross-connect block.
- Figure A-4 shows the connections between a phone system with an RJ-11 connector and the primary and secondary master PIMG units.
- Figure A-5 shows the connections between a phone system with an RJ-14 connector and the primary and secondary master PIMG units.

Figure 3: Figure A-3 Connections from the Phone System Through a Punchdown Block

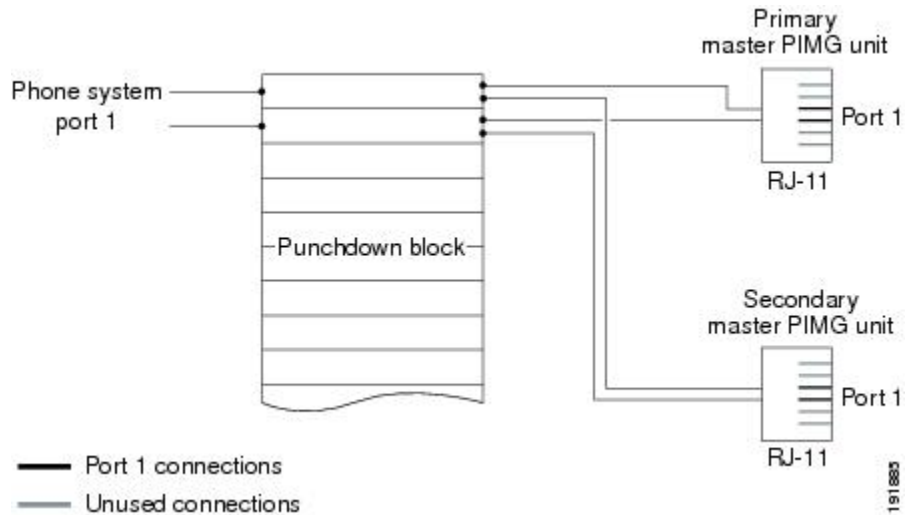

Figure 4: Figure A-4 Connections for an RJ-11 Connector from the Phone System

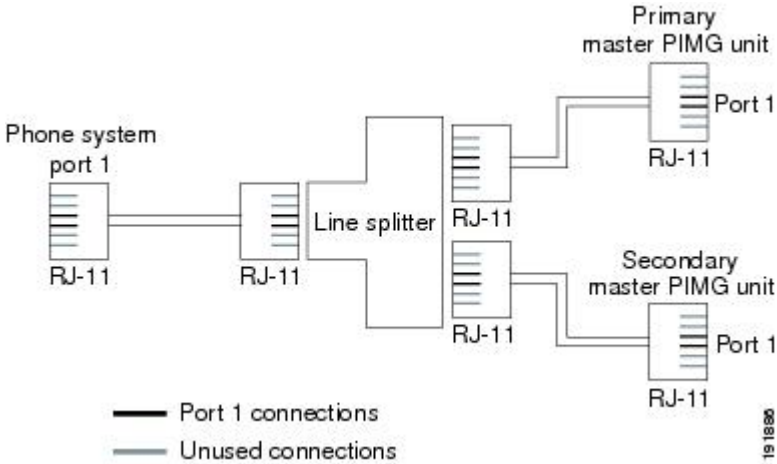
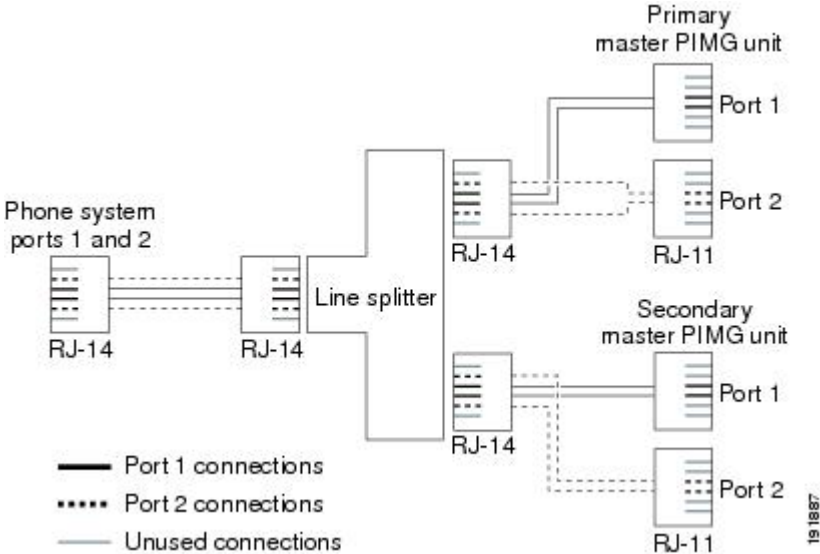

Figure 5: Figure A-5 Connections for an RJ-11 Connector from the Phone System



# Serial Data Cable Connections for the Master PIMG Units

Connecting the RS-232 serial cables between a circuit-switched phone system and the primary and secondary master PIMG varies depending on the number of serial ports the phone system has.

## Requirements

The following components are required for phone systems with only one serial port:

- Three RS-232 serial cables
- Data splitter unit

The following components are required for phone systems with multiple serial ports:

- Two RS-232 serial cables

## Connections for the Serial Data Cables

Figure A-6 shows the connections between the serial port on a phone system that has only one serial port to the serial ports on the primary and secondary master PIMG units. Figure A-6 shows the connections between the serial ports on a phone system that has two serial ports to the serial ports on the master PIMG units.

Note that the following figures do not show the analog voice lines, which are described in the [Analog Voice Line Connections for the Master PIMG Units](#).

**Figure 6: Figure A-6 Serial Cable Connections from a Single Serial Port on the Phone System to the Serial Ports on the Master PIMG Units**

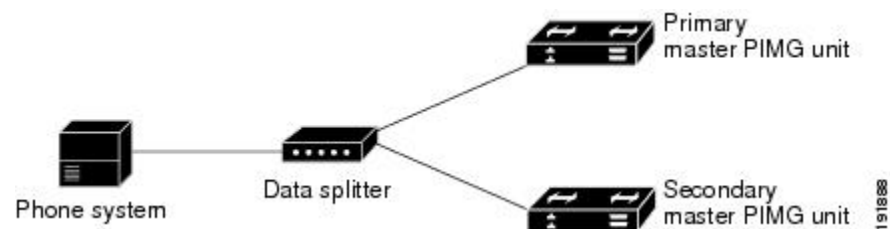

**Figure 7: Figure A-7 Serial Cable Connections from Multiple Serial Ports on the Phone System to the Serial Ports on the Master PIMG Units**



## Configuring the Secondary Master PIMG Unit

This procedure has the following requirements:

- All analog lines and serial cables must be correctly connected.
- The primary secondary master PIMG units must have the same firmware version installed.
- The primary master PIMG unit is connected to power, while the secondary master PIMG unit is disconnected from power.
- You have a Windows workstation that has access to the PIMG units.

Do the following procedure to make the configuration of the secondary master PIMG unit match the configuration of the primary master PIMG unit.

## Configuring the Secondary Master PIMG Unit

### SUMMARY STEPS

1. On a Windows workstation, in a web browser, sign in to the primary master PIMG unit.

2. On the Configuration menu, select **Import/Export**.
3. On the Import/Export page, under Export Files, select **Export All Settings**.
4. In the File Download dialog box, select **Save**.
5. In the Save As dialog box, browse to the Windows workstation, browse to a directory where you want to save the file, and select **Save**.
6. Exit the PIMG web interface.
7. Disconnect power from the primary master PIMG unit.
8. Connect power to the secondary master PIMG unit.
9. On the Windows workstation, in a web browser, sign in the secondary master PIMG unit by entering the following case-sensitive settings.
10. Select **OK**.
11. On the Configuration menu of the secondary master PIMG unit, select **Import/Export**.
12. On the Import/Export page, under Import File, select **Browse**.
13. In the Choose File dialog box, browse to the file Config.ini that you saved from the primary master PIMG unit in [Step 5](#).
14. Select **Config.ini**, and select **Open**.
15. On the Import/Export page, select **Import File**.
16. When prompted to restart the PIMG unit, select **OK**.
17. Disconnect power from the secondary master PIMG unit.
18. Connect power to the primary master PIMG unit.

## DETAILED STEPS

- 
- Step 1** On a Windows workstation, in a web browser, sign in to the primary master PIMG unit.
  - Step 2** On the Configuration menu, select **Import/Export**.
  - Step 3** On the Import/Export page, under Export Files, select **Export All Settings**.
  - Step 4** In the File Download dialog box, select **Save**.
  - Step 5** In the Save As dialog box, browse to the Windows workstation, browse to a directory where you want to save the file, and select **Save**.
  - Step 6** Exit the PIMG web interface.
  - Step 7** Disconnect power from the primary master PIMG unit.
  - Step 8** Connect power to the secondary master PIMG unit.
  - Step 9** On the Windows workstation, in a web browser, sign in the secondary master PIMG unit by entering the following case-sensitive settings.

*Table 1: Default Sign-in Settings*

Field	Setting
Username	Enter <b>admin</b> .
Password	Enter <b>IpodAdmin</b> .

- Step 10** Select **OK**.
- Step 11** On the Configuration menu of the secondary master PIMG unit, select **Import/Export**.

- Step 12** On the Import/Export page, under Import File, select **Browse**.
- Step 13** In the Choose File dialog box, browse to the file Config.ini that you saved from the primary master PIMG unit in [Step 5](#).
- Step 14** Select **Config.ini**, and select **Open**.
- Step 15** On the Import/Export page, select **Import File**.
- Step 16** When prompted to restart the PIMG unit, select **OK**.
- Step 17** Disconnect power from the secondary master PIMG unit.
- Step 18** Connect power to the primary master PIMG unit.
-

