



Call Coverage Features

- [Information About Call Coverage Features, on page 1](#)
- [Configure Call Coverage Features, on page 40](#)
- [Configuration Examples for Call Coverage Features, on page 96](#)
- [Where to Go Next, on page 119](#)
- [Feature Information for Call Coverage Features, on page 121](#)

Information About Call Coverage Features

Call Coverage Summary

Call coverage features are used to ensure that all incoming calls to Cisco Unified CME are answered by someone, regardless of whether the called number is busy or does not answer.

Some single-dialed-number call coverage features, such as hunt groups, can send incoming calls to a single extension to a pool of phone agents, while other features, such as call hunt, call waiting, and call forwarding increase the chance of a call being answered by giving it another chance for a connection if the dialed number is not available.

Multiple-dialed-number call coverage features, such as call pickup, night service, and overlaid directory numbers, provide different ways for one person to answer incoming calls to multiple numbers.

Any of the call coverage features can be combined with other call coverage features and with shared lines and secondary numbers to design the call coverage plan that is best suited to your needs.

[Table 1: Call Coverage Feature Summary, on page 1](#) summarizes call coverage features.

Table 1: Call Coverage Feature Summary

Feature	Description	Example	How Configured
Call Forwarding	Calls are automatically diverted to a designated number on busy, no answer, all calls, or only during night-service hours.	Extension 3444 is configured to send calls to extension 3555 when it is busy or does not answer.	Enable Call Forwarding for a Directory Number or Configure SIP-to-SIP Phone Call Forwarding

Feature	Description	Example	How Configured
Call Hunt	System automatically searches for an available directory number from a matching group of directory numbers until the call is answered or the hunt is stopped.	Three ephone-dns have the same extension number, 755. One is on the manager's phone and the others are on the assistants' phones. Preference and huntstop are used to make sure that calls always come to the manager's phone first but if they can't be answered, they will ring on the first assistant's phone and if not answered, on the second assistant's phone.	Configure Call Hunt on SCCP Phones, on page 40 or Configure Call Hunt on SIP Phones, on page 43
Call Pickup	Calls to unstaffed phones can be answered by other phone users using a soft key or by dialing a short code.	Extension 201 and 202 are both in pickup group 22. A call is received by 201, but no one is there to answer. The agent at 202 presses the GPickUp soft key to answer the call.	Enable Call Pickup, on page 44
Call Waiting	Calls to busy numbers are presented to phone users, giving them the option to answer them or let them be forwarded.	Extension 564 is in conversation when a call-waiting beep is heard. The phone display shows the call is from extension 568 and the phone user decides to let the call go to voice mail.	Configure Call-Waiting Indicator Tone on SCCP Phone, on page 48 or Enable Call Waiting on SIP Phones, on page 52
Cisco CME B-ACD	Calls to a pilot number are automatically answered by an interactive application that presents callers with a menu of choices before sending them to a queue for a hunt group.	The DID number 555-0125 is the pilot number for the XYZ Company. Incoming calls to this pilot number hear a menu of choices; they can press 1 for sales, 2 for service, or 3 to leave a message. The call is forwarded appropriately when callers make a choice.	See Cisco Unified CME B-ACD and Tcl Call-Handling Applications .
Hunt Groups	Calls are forwarded through a pool of agents until answered or sent to a final number.	Extension 200 is a pilot number for the sales department. Extensions 213, 214, and 215 belong to sales agents in the hunt group. When a call to extension 200 is received, it proceeds through the list of agents until one answers. If all the agents are busy or do not answer, the call is sent to voice mail.	Configure Ephone-Hunt Groups on SCCP Phones, on page 54 or Configure Voice-Hunt Groups, on page 63
Night Service	Calls to ephone-dns and voice register dns that are not staffed during certain hours can be answered by other phones using call pickup.	Extension 7544 is the cashier's desk but the cashier only works until 3 p.m. A call is received at 4:30 p.m. and the service manager's phone is notified. The service manager uses call pickup to answer the call.	Configure Night Service on SCCP Phones, on page 77 Configure Night Service on SIP Phones, on page 80

Feature	Description	Example	How Configured
Overlaid Ephone-dns	Calls to several numbers can be answered by a single agent or multiple agents.	Extensions 451, 452, and 453 all appear on button 1 of a phone. A call to any of these numbers can be answered from button 1.	Configure Overlaid Ephone-dns on SCCP Phones, on page 89.

Out-of-Dialog REFER

Out-of-dialog REFER (OOD-R) allows remote applications to establish calls by sending a REFER message to Cisco Unified CME without an initial INVITE. After the REFER is sent, the remainder of the call setup is independent of the application and the media stream does not flow through the application. The application using OOD-R triggers a call setup request that specifies the Referee address in the Request-URI and the Refer-Target in the Refer-To header. The SIP messaging used to communicate with Cisco Unified CME is independent of the end-user device protocol which can be SIP, SCCP, H.323, or POTS. Click-to-dial is an example of an application that can be created using OOD-R.

A click-to-dial application allows users to combine multiple steps into one click for a call setup. For example, a user can click a web-based directory application from their PC to look up a telephone number, off-hook their desktop phone, and dial the called number. The application initiates the call setup without the user having to out-dial from their own phone. The directory application sends a REFER message to Cisco Unified CME which sets up the call between both parties based on this REFER.

[Figure 1: Click-to-Dial Application using Out-of-Dialog REFER, on page 3](#) shows an example of OOD-R being used by a click-to-dial application. In this scenario, the following events occur (refer to the event numbers in the illustration):

1. Remote user clicks to dial.
2. Application sends out-of-dialog REFER to Cisco Unified CME 1.
3. Cisco Unified CME 1 connects to SIP phone 1 (Referee).
4. Cisco Unified CME 1 sends INVITE to Cisco Unified CME 2.
5. Cisco Unified CME 2 sends INVITE to SIP phone 2 (Refer-Target) and the call is accepted.
6. Voice path is created between the two SIP phones.

Figure 1: Click-to-Dial Application using Out-of-Dialog REFER

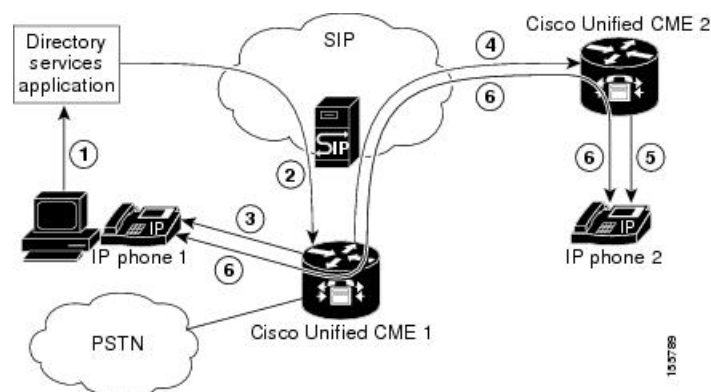

The initial OOD-R request can be authenticated and authorized using RFC 2617-based digest authentication. To support authentication, Cisco Unified CME retrieves the credential information from a text file stored in flash. This mechanism is used by Cisco Unified CME in addition to phone-based credentials. The same credential file can be shared by other services that require request-based authentication and authorization such as presence service. Up to five credential files can be configured and loaded into the system. The contents of these five files are mutually exclusive, meaning the username and password pairs must be unique across all the files. The username and password pairs must also be different than those configured for SCCP or SIP phones in a Cisco Unified CME system.

For configuration information, see [Enable Out-Of-Dialog REFER, on page 93](#).

Call Hunt

Call hunt allows you to use multiple directory numbers to provide coverage for a single called number. You do this by assigning the same number to several primary or secondary ephone-dns or by using wildcards in the number associated with the directory numbers.

Calls are routed based on a match between the number dialed and the destination patterns that are associated with dial peers. Through the use of wildcards in destination patterns, multiple dial peers can match a particular called number. Call hunt is the ability to search through the dial peers that match the called number until the call is answered. Call hunt uses a technique called preference to control the order in which dial peers are matched to an incoming call and a technique called huntstop to determine when the search for another matching peer ends.

In Cisco Unified CME, incoming calls search through the virtual dial peers that are automatically created when you define directory numbers. These virtual dial peers are not directly configurable; you must configure the directory number to control call hunt for virtual dial peers.

Channel huntstop is used to stop the search for the two channels of a dual-line directory number. Channel huntstop keeps incoming calls from hunting to the second channel if the first channel is busy or does not answer. This keeps the second channel free for call transfer, call waiting, or three-way conferencing.

Huntstop prevents hunt-on-busy from redirecting a call from a busy phone into a dial peer that has been setup with a catch-all default destination.

For configuration information, see [Configure Call Hunt on SCCP Phones, on page 40](#) or [Configure Call Hunt on SIP Phones, on page 43](#).

Call Pickup

Call Pickup allows a phone user to answer a call that is ringing on another phone. Cisco Unified CME 7.1 introduces Call Pickup features for SIP phones. SCCP phones support three types of Call Pickup:

- **Directed Call Pickup**—Call pickup, explicit ringing extension. Any local phone user can pick up a ringing call on another phone by pressing a soft key and then dialing the extension. A phone user does not need to belong to a pickup group to use this method. The soft key that the user presses, either GPickUp or PickUp, depends on your configuration.
- **Group Pickup, Different Group**—Call pickup, explicit group ringing extension. A phone user can answer a ringing phone in any pickup group by pressing the GPickUp soft key and then dialing the pickup group number. If there is only one pickup group defined in the Cisco Unified CME system, the phone user can pick up the call simply by pressing the GPickUp soft key. A phone user does not need to belong to a pickup group to use this method.

- Local Group Pickup—Call pickup, local group ringing extension. A phone user can pick up a ringing call on another phone by pressing a soft key and then the asterisk (*) if both phones are in the same pickup group. The soft key that the user presses, either GPickUp or PickUp, depends on your configuration.



Note SIP phones only support local pickup and group pickup. Directed call pickup is not supported.

The specific soft keys used to access different Call Pickup features on SCCP and SIP phones depends on the configuration in Cisco Unified CME. See the **service directed-pickup** command in [Cisco Unified CME Command Reference](#) for a description.

You can assign each directory number to only one pickup group and a directory number must have a pickup group configured to use Local Group Pickup. There is no limit to the number of directory numbers that can be assigned to a single pickup group, or to the number of pickup groups that can be defined in a Cisco Unified CME system.

If more than one call is ringing on the same number, the calls are picked up in the order in which they were received; the call that has been ringing the longest is the first call picked up from that extension number. Remote call pickup is not supported.

Call Pickup features are enabled globally for all phones through Cisco Unified CME. The PickUp and GpickUp soft keys display on supported SCCP and SIP phones by default and can be modified by using a phone template. For configuration information, see [Enable Call Pickup, on page 44](#).

[Figure 2: Call Pickup, on page 6](#) shows four call-pickup scenarios.

Figure 2: Call Pickup

Call Pickup, No Group or Unknown Group

- 1 Extension 5555 rings.
- 2 User at phone 4 presses PickUp soft key and dials 5555.



```
ephone-dn 55
number 5555
pickup-group 33
```

```
ephone-dn 56
number 5556
pickup-group 33
```

```
ephone-dn 57
number 5557
pickup-group 44
```

Call Pickup in the Same Group

- 1 Extension 5555 rings.
- 2 User at phone 2 presses GPickUp soft key and * (asterisk).



```
ephone-dn 58
number 5558
```

```
ephone 1
mac-address 1111.1111.1111
button 1:55
```

```
ephone 2
mac-address 2222.2222.2222
button 1:56
```

```
ephone 3
mac-address 3333.3333.3333
button 1:57
```

Call Pickup from a Different Group

- 1 Extension 5555 rings.
- 2 User at phone 3 presses GPickUp soft key and dials 33.



```
ephone 4
mac-address 4444.4444.4444
button 1:58
```

Call Pickup, a Single Group for All Cisco CME Phones

- 1 Extension 5555 rings.
- 2 User at phone 2 presses GPickUp soft key.



This scenario assumes that every phone in the Cisco CME system is in pickup group 33, which differs slightly from the sample configuration shown to the right.

14-6888

Call Waiting

Call waiting allows phone users to be alerted when they receive an incoming call while they are on another call. Phone users hear a call-waiting tone when another party is trying to reach them and, on IP phones, see the calling party information on the phone screen.

Call-waiting calls to IP phones with soft keys can be answered using the Answer soft key. Call-waiting calls to analog phones controlled by Cisco Unified CME systems are answered using hookflash. When phone users answer a call-waiting call, their original call is automatically put on hold. If a phone user does not respond to a call-waiting notification, the call is forwarded as specified in the **call-forward noan** command for that extension.

For an IP phone running SCCP, call waiting for single-line ephone-dns requires two ephone-dns to handle the two calls. Call waiting on a dual-line ephone-dn requires only one ephone-dn because the two channels of the ephone-dn handle the two calls. The audible call-waiting indicator can be either a call-waiting beep or a call-waiting ring. For configuration information, see [Configure Call-Waiting Indicator Tone on SCCP Phone, on page 48](#).

For a SIP phone, call waiting is automatically enabled when you configure a voice register pool. For SIP phones directly connected to Cisco Unified CME, call waiting can be disabled at the phone-level. For configuration information, see [Enable Call Waiting on SIP Phones, on page 52](#).

For information on call waiting using Overlaid ephone-dns, see [Overlaid Ephone-dns, on page 35](#).

Call-Waiting Beep for SCCP Phones

Call-waiting beeps are enabled by default. You can disable the call-waiting beeps that are generated from and accepted by directory numbers. If beep generation is disabled, incoming calls to the directory number do not generate call-waiting beeps. If beep acceptance is disabled, the phone user does not hear beeps when using the directory number for an active call.

[Table 2: Call-Waiting Beep Behavior, on page 7](#) shows the possible beep behaviors of one ephone-dn calling another ephone-dn that is connected to another caller.

Table 2: Call-Waiting Beep Behavior

Ephone-dn 1 Configuration	Ephone-dn 2 Configuration	Active Call on DN	Incoming Call on DN	Expected Behavior
—	no call-waiting beep	DN 1	DN 2	No beep
no call-waiting beep	—	DN 1	DN 2	No beep
—	no call-waiting beep generate	DN 1	DN 2	No beep
—	no call-waiting beep accept	DN 1	DN 2	Beep
—	no call-waiting beep acceptno call-waiting beep generate	DN 1	DN 2	No beep
no call-waiting beep	—	DN 1	DN 1	No beep

Ephone-dn 1 Configuration	Ephone-dn 2 Configuration	Active Call on DN	Incoming Call on DN	Expected Behavior
no call-waiting beep generate	—	DN 1	DN 1	No beep
no call-waiting beep accept	—	DN 1	DN 1	No beep
no call-waiting beep accept no call-waiting beep generate	—	DN 1	DN 1	No beep
no call-waiting beep generate	—	DN 1	DN 2	Beep
no call-waiting beep accept	—	DN 1	DN 2	No beep
—	no call-waiting beep	DN 1	DN 1	Beep

Call-Waiting Ring for SCCP Phones

Instead of the standard call-waiting beep sound through the handset, you can use a short ring for call-waiting notification. The default is for directory numbers to accept call interruptions, such as call waiting, and to issue a beeping sound for notification.

To use a ring sound, the directory number must accept call-waiting indicator tones. For configuration information, see [Configure Call-Waiting Indicator Tone on SCCP Phone, on page 48](#) or [Enable Call Waiting on SIP Phones, on page 52](#).

Cancel Call Waiting

Cancel Call Waiting (CCW) enables an SCCP phone user to disable Call Waiting for a call they originate. The user activates CCW, and thereby disables call waiting, by pressing the cancel call waiting (CW Off) soft key or by dialing the feature access code (FAC) before placing a call. Call Waiting is inactive during that call; anyone calling the user receives normal busy treatment and no call waiting tone interrupts the user's active call. CCW automatically deactivates when the user disconnects from the call. CCW is supported on all lines that support the Call Waiting feature, including dual-lines and octo-lines.

This feature is supported in Cisco Unified CME 8.0 and later versions for SCCP IP phones and SCCP analog phones; it is not supported on SIP phones.

For configuration information, see [Configure Cancel Call Waiting on SCCP Phone, on page 50](#).

Callback Busy Subscriber

This feature allows callers who dial a busy extension number to request a callback from the system when the called number is available. Callers can also request callbacks for extensions that do not answer, and the system will notify them after the called phone is next used.

There can be only one callback request pending against a particular extension number, although a caller can initiate more than one callback to different numbers. If a caller attempts to place a callback request on a number that already has a pending callback request, the caller hears a fast-busy tone. If the called number has call forwarding enabled, the callback request is placed against the final destination number.

No configuration is required for this feature. To display a list of phones that have pending callback requests, use the **show ephone-dn callback** command.

Hunt Groups

Hunt groups allow incoming calls to a specific number (pilot number) to be directed to a defined group of extension numbers.

Incoming calls are redirected from the pilot number to the first extension number as defined by the configuration. If the first number is busy or does not answer, the call is redirected to the next phone in the list. A call continues to be redirected on busy or no answer from number to number in the list until it is answered or until the call reaches the number that is defined as the final number.

The redirect from one directory number to the next in the list is also known as a *hop*. You can set the maximum number of redirects for specific peer or longest-idle hunt groups, and for the maximum number of redirects allowed in a Cisco Unified CME system, both inside and outside hunt groups. If a call makes the maximum number of hops or redirects without being answered, the call is dropped.

In Cisco Unified CME 9.0 and later versions, support for call statistics is added for voice hunt groups. To write all the ephone and voice hunt group statistics to a file, the **ephone-hunt statistics write-all** command is enhanced and renamed to **hunt-group statistics write-all** command. If applicable, the TFTP statistics report consists of both ephone and voice hunt group statistics.

In Cisco Unified CME 9.5 and later versions, the command **hunt-group statistics write-v2** is added to write all ephone hunt group statistics to a file along with total logged in and logged out time for agents. The command was enhanced in Unified CME Release 11.5 to add statistics for total logged in and logged out time for voice hunt group.

The **show telephony-service all** command is also enhanced to display the total number of ephone and voice hunt groups that have statistics collection turned on.

The **statistics collect** command under voice hunt-group configuration mode is introduced to enable the collection of call statistics for a voice hunt group.

The **show voice hunt-group statistics** command is introduced to display call statistics from voice hunt groups.

For Unified CME 11.5 and later versions, the **overwrite-dyn-stats (voice hunt-group)** command is introduced to overwrite statistics of previously joined dynamic agent with stats of newly joined dynamic agents for voice hunt group. The statistics for a dynamic agent are overwritten only when all the 32 available slots are used. For more information, see [Cisco Unified Communications Manager Express Command Reference Guide](#).

For Unified CME 12.2 and later versions, Sequential, Parallel, Peer, and Longest Idle voice hunt groups support SIP shared line and mixed shared line (SIP and SCCP Phones) directory numbers. All shared line features such as Hold and Remote resume, Barge, cBarge, Privacy, and calls through B-ACD is supported for calls that are placed through voice hunt groups.

The following are the known behavior patterns for the voice hunt group enhancement with shared line support, introduced in Unified CME Release 12.2:

- When you press the Decline softkey on one of the shared line DN (configured across phones) in a voice hunt group for an incoming call, the shared line DN on the other phones continue ringing. This behavior is typical to shared line DN in a voice hunt group. For all shared lines that are not part of a voice hunt group, when you press the Decline softkey, all the corresponding shared line DN stop ringing.
- Hlog feature is not supported on a shared DN. If a phone configured with Hlog has a shared DN as part of voice hunt group, then the Hlog functionality is supported only for the other lines that are part of voice hunt group on that phone.

For information on displaying statistics for hunt groups, see [Cisco Unified CME B-ACD and Tel Call-Handling Applications](#).

There are four different types of hunt groups. Each type uses a different strategy to determine the first number that rings for successive calls to the pilot number, as described below.

- **Sequential Hunt Groups**—Numbers always ring in the left-to-right order in which they are listed when the hunt group is defined. The first number in the list is always the first number to be tried when the pilot number is called. Maximum number of hops is not a configurable parameter for sequential hunt groups. [Figure 3: Sequential hunt Group, on page 12](#) shows an illustrated example.
- **Peer Hunt Groups**—The first number to ring is the number to the right of the directory number that was the last to ring when the pilot number was last called. Ringing proceeds in a circular manner, left to right, for the number of hops specified in the hunt group configuration. [Figure 4: Peer hunt Group, on page 13](#) shows an illustrated example.
- **Longest-Idle Hunt Groups**—Calls go first to the number that has been idle the longest for the number of hops specified when the hunt group was defined. The longest-idle time is determined from the last time that a phone registered, reregistered, or went on-hook. [Figure 5: Longest-idle hunt Group, on page 14](#) shows an illustrated example.
- **Parallel Hunt Groups (Call Blast)**—Calls ring all numbers in the hunt group simultaneously.

Ephone Hunt-group chains can be configured in any length, but the actual number of hops that can be reached in a chain is determined by the **max-redirect** command configuration. In the following example, a maximum redirect number 15 or greater must be configured for callers to reach the final 5000 number. If a lower number is configured, the call disconnects.

```
ephone-hunt 1 sequential
pilot 8000
list 8001, 8002, 8003, 8004
final 9000
```

```
ephone-hunt 2 sequential
pilot 9000
list 9001, 9002, 9003, 9004
final 7000
```

```
ephone-hunt 3 sequential
pilot 7000
list 7001, 7002, 7003, 7004
final 5000
```

Cisco Unified CME 4.3 and later versions support the following Voice Hunt-Group features:

- Call Forwarding to a Parallel Voice Hunt-Group (Call Blast)
- Call Transfer to a Voice Hunt-Group
- Member of Voice Hunt-Group can be a SIP phone, SCCP phone, FXS analog phone, DS0-group, PRI-group, or SIP trunk.

- Unified CME supports chaining (nesting) of a voice hunt group with another voice hunt group. The chaining of voice hunt groups is established by configuring the final number of the first voice hunt group as the pilot number of the second voice hunt group.



Note For Unified CME B-ACD, the final destination for voice hunt groups is determined by the B-ACD service.

- Unified CME supports the chaining (nesting) of a maximum of two voice hunt groups. The configuration ensures that there is no looping of calls placed to a voice hunt group.

Ephone-Hunt Groups and Voice Hunt-Groups Comparison

SIP phones support Voice Hunt-Groups. SCCP phones support Ephone-Hunt Groups, and in Cisco Unified CME 4.3 and later versions, SCCP phones also support Voice Hunt-Groups. [Table 3: Feature Comparison of Ephone-Hunt Groups and Voice Hunt-Groups, on page 11](#) compares the features of Ephone-Hunt Groups and Voice Hunt-Groups.

Table 3: Feature Comparison of Ephone-Hunt Groups and Voice Hunt-Groups

Feature	Ephone Hunt	Voice Hunt Group
Endpoints Supported	SCCP only	SIP, SCCP, PSTN, and FXS
Parallel Hunt Groups (Call Blast)	No (for alternative, see Shared-Line Overlays, on page 37)	Yes
Hunt Statistics Support	Yes	Yes
B-ACD Support	Yes	Yes
Shared Line	Yes	Yes
Features such as present-call and login/logout	Yes	Yes (Only for SIP and SCCP phones)

Sequential Hunt Groups

In a sequential hunt group, extensions always ring in the order in which they are listed, left to right, when the hunt group is defined. The first number in the list is always the first number to be tried when the pilot number is called. Maximum number of hops is not a configurable parameter for sequential hunt groups.

From Unified CME 12.2 onwards, sequential voice hunt groups support shared lines and mixed shared lines. When calls are placed on a sequential voice hunt group and a shared DN is part of the hunt group, the call is placed sequentially. For the shared DN, the call would ring on all phones part of this shared DN. If none of the phones answer, then call would continue to the next DN in the hunt group.



Note Consecutive numbers of the same phone cannot be members of a Sequential Voice Hunt Group when present call idle state (configured using the CLI command **present-call idle-phone**) is set to true. The limitation applies to both SIP and SCCP phones.

Figure 3: Sequential hunt Group

- ① Any phone dials the pilot number, 5601.
- ② Extension 5001, the leftmost number in the hunt group list, rings first on phone 1. If extension 5001 is busy or does not answer, the call is redirected to extension 5002 on phone 2.
- ③ If extension 5002 on phone 2 is busy or does not answer, the call is redirected to extension 5017 on phone 3.
- ④ If phone 3 is busy or does not answer, the call is redirected to the final number, extension 6000, which is associated with a voice-mail server.

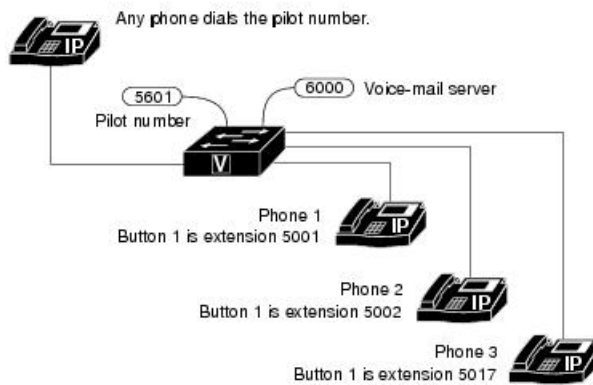

```
ephone-dn 88
  number 5001

ephone-dn 89
  number 5002

ephone-dn 90
  number 5017

ephone 1
  mac-address 1111.1111.1111
  button 1:88

ephone 2
  mac-address 2222.2222.2222
  button 1:89

ephone 3
  mac-address 3333.3333.3333
  button 1:90

ephone-hunt 1 sequential
  pilot 5601
  list 5001, 5002, 5017
  final 6000
  preference 1
  timeout 30
```

15
883

Peer Hunt Groups

In a peer hunt group, extensions ring in a round-robin order. The first extension to ring is the number in the list to the right of the last extension to ring when the pilot number was last called. Ringing proceeds in a circular manner, left to right, for the number of hops specified when the hunt group was defined.

From Unified CME 12.2 onwards, peer voice hunt groups support shared and mixed shared lines. When calls are placed on a peer voice hunt group and a shared DN is part of the hunt group, the call is placed in a round-robin order. For the shared DN, the call would ring on all phones part of this shared DN. If none of the phones answer, then call would continue to the next DN in the hunt group.

Figure 4: Peer hunt Group, on page 13 illustrates a peer hunt group.

Figure 4: Peer hunt Group

- ① Any phone dials the pilot number, 5601, which is not associated with a physical phone instrument.
- ② Extension 5017 on phone 3 is selected to ring first because extension 5002 was the last number to ring the last time that the pilot number was called.
- ③ If extension 5017 is busy or does not answer, the call is redirected to extension 5044 on phone 4 (first hop).
- ④ If extension 5044 is busy or does not answer, the call is redirected to extension 5001 on phone 1 (second hop).
- ⑤ If extension 5001 is busy or does not answer, the call has reached the maximum number of hops (3), and it is redirected to the final number, extension 6000, which is associated with a voice-mail server.

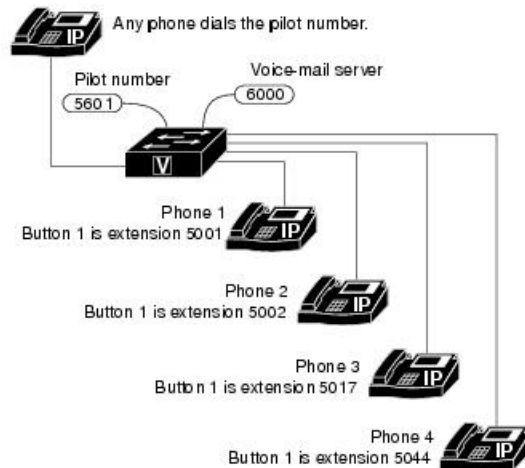

```

ephone-dn 88
  number 5001

ephone-dn 89
  number 5002

ephone-dn 90
  number 5017

ephone-dn 91
  number 5044

ephone 1
  mac-address 1111.1111.1111
  button 1:88

ephone 2
  mac-address 2222.2222.2222
  button 1:89

ephone 3
  mac-address 3333.3333.3333
  button 1:90

ephone 4
  mac-address 4444.4444.4444
  button 1:91

ephone-hunt 1 peer
  pilot 5601
  list 5001, 5002, 5017, 5044
  final 6000
  hops 3
  preference 1
  timeout 30
  no-reg

```

88930

Longest-Idle Hunt Groups

In a longest-idle hunt group, the algorithm for choosing the next extension to receive a call is based on a comparison of on-hook time stamps. The extension with the smallest on-hook time stamp value is chosen when the next call comes to the hunt group.

The default behavior is that an on-hook time stamp value for an extension is updated only when the agent answers a call. In Cisco Unified CME 4.0 and later versions, you can specify that an on-hook time stamp is updated when a call rings an extension and also when a call is answered by an agent.

From Unified CME 12.2 onwards, longest-idle voice hunt groups support shared lines and mixed shared lines. When calls are placed on a longest-idle voice hunt group and a shared DN is part of the hunt group, the call is placed based on a comparison of on-hook time stamps. For the shared DN, the call would ring on all phones part of this shared DN. If none of the phones answer, then call would continue to the next DN in the hunt group.

Figure 5: Longest-idle hunt Group, on page 14 illustrates a longest-idle hunt group.

Figure 5: Longest-idle hunt Group

- ① Any phone dials the pilot number, 5601, which is not associated with a physical phone instrument.
- ② Extension 5001 on phone 1 is selected to ring first because it has been idle the longest.
- ③ If extension 5001 does not answer, the call is redirected to extension 5002 on phone 2 because it has been idle the longest (first hop).
- ④ If extension 5002 does not answer, the call is redirected to extension 5044 on phone 4 because it has been idle the longest (second hop).
- ⑤ If extension 5044 does not answer, the call has reached the maximum number of hops (3), and it is redirected to the final number, extension 6000, which is associated with a voice-mail server.

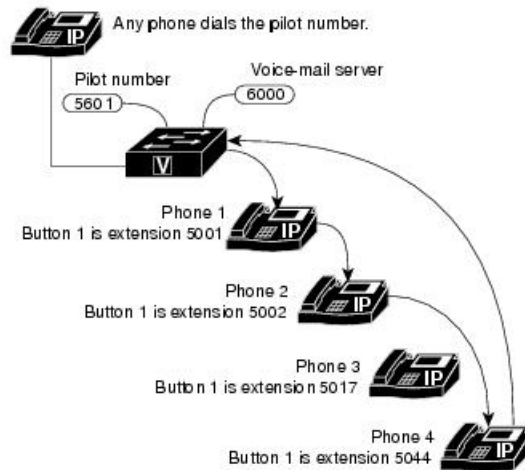

```

ephone-dn 88
  number 5001

ephone-dn 89
  number 5002

ephone-dn 90
  number 5017

ephone-dn 91
  number 5044

ephone 1
  mac-address 1111.1111.1111
  button 1:88

ephone 2
  mac-address 2222.2222.2222
  button 1:89

ephone 3
  mac-address 3333.3333.3333
  button 1:90

ephone 4
  mac-address 4444.4444.4444
  button 1:91

ephone-hunt 1 longest-idle
  pilot 5601
  list 5001, 5002, 5017, 5044
  final 6000
  hops 3
  preference 1
  timeout 30
  no-reg

```

103398

Parallel Hunt Groups (Call Blast)

In a parallel hunt group, calls simultaneously ring multiple phones. Using parallel hunt groups is also referred to as application-level forking because it enables the forking of a call to multiple destinations. In versions earlier than Cisco Unified CME 4.3, only SIP phones support parallel hunt groups. In Unified CME 4.3 and later versions, SCCP phones also support voice hunt groups.

You can enable functionality similar to parallel hunt groups on SCCP phones by using the ephone-dn overlay feature for shared lines. See [Shared- Line Overlays, on page 37](#).

From Unified CME 12.2 onwards, parallel voice hunt groups support shared lines and mixed shared lines. For parallel voice hunt groups, a maximum of 32 call blasts is supported, including shared-line and normal directory numbers. For example, consider a voice hunt group configured with 20 directory numbers, including 3 shared-lines assigned across three different phones. In this scenario, the count of shared line directory numbers is considered as 9 (3*3). Then, the total count of call blasts in this hunt group is 26 directory numbers (17 + 9). When the call blast limit of 32 is exceeded, then call is not placed for those voice hunt group directory numbers that exceed the limit.

In the following parallel hunt group example, when callers dial extension 1000, extension 1001, 1002, and so on ring simultaneously. The first extension to answer is connected. If none of the extensions answers, the call is forwarded to extension 2000, which is the number for the voice-mail service.

```

voice hunt-group 4 parallel
  pilot 1000
  list 1001, 1002, 1003, 1004
  final 2000

```

timeout 20

The number of ringing calls that a parallel hunt group can support depends on whether call-waiting is enabled on the SIP phones.

If call-waiting is enabled (the default), parallel hunt groups support multiple calls up to the limit of call-waiting calls supported by a particular SIP phone model. You may not want to use unlimited call-waiting, however, with parallel hunt-groups if agents do not want a large number of waiting calls when they are already handling a call.

If call waiting is disabled, parallel hunt groups support only one call at a time in the ringing state. After a call is answered (by one of the phones in the hunt group), a second call is allowed. The second and subsequent calls ring only the idle phones in the hunt group, and bypass the busy phone that answered the first call (because this phone is connected to the first call). After the second call is answered, a third call is allowed, and so on until all the phones in the parallel hunt group are busy. The hunt group does not accept further calls until at least one phone returns to the idle/on-hook state.

When two or more phones within the same parallel hunt group attempt to answer the same call, only one phone can connect to the call. Phones that fail to connect must return to the on-hook state before they can receive subsequent calls. Calls that arrive before a phone is placed on-hook are not presented to the phone. For example, if a second call arrives after Phone 1 has answered the original call, but before Phone 2 goes back on-hook, the second call bypasses Phone 2 (because it is offhook).

When a phone returns to the idle/on-hook state, it does not automatically re-synchronize to the next call waiting to be answered. For example, in the previous scenario, if the second call is still ringing Phone 3 when Phone 2 goes on-hook, Phone 2 does not ring because it was offhook when the second call arrived.

For configuration information, see [Configure Voice-Hunt Groups, on page 63](#).

View and Join for Voice Hunt Groups

You can view voice hunt group related information on SIP and SCCP phones using the phone menu. The following information related to hunt groups can be viewed on the phone display:

- Name
- Pilot number
- Status

If voice hunt groups have been configured, the user can view the voice hunt group information using the service button on the phone, by navigating to **My Phone Apps > Voice Hunt Groups**. On selecting the voice hunt group option, a list of voice hunt groups will be displayed.

A voice hunt group includes the name of the hunt group, the pilot number and also the status of the DN indicating if the DN is a member of the hunt group. This information is displayed in the following method:

- If DN is a static member of the hunt group, then status is displayed with # (hash) symbol.
- If DN is dynamic member, the status is displayed with * (asterisk) symbol.

The following operations can be performed on the phone user interface:

- User can join or unjoin to or from voice hunt groups by selecting the **Join** or **Unjoin** softkey which is displayed on the voice hunt group page. The user can select the required voice hunt group using the up and down buttons.

- User can access the next or previous records of voice hunt groups by selecting the **Next/Previous** softkey options.

To display voice hunt-group information on the phone, user needs to configure **phone-display** command under voice hunt-groups.

Restrictions and Limitations

- A DN can join a maximum of six voice hunt groups.
- The displayed hunt group information is applicable only for the primary line of the phone.
- A primary DN can join or unjoin a voice hunt group using the **Service** button on the phone. If a phone is configured with multiple DNs, then DNs other than the primary DN can join the voice hunt groups by dialing the FAC standards.
- The voice hunt group information display feature is applicable only on the phones that support **My Phone Apps** menu. For example, 78xx, 88xx phone families are supported. However, 69xx, 39xx phone families are not supported.

Enable User Interface to View, Join, and Unjoin Voice Hunt Groups on SCCP Phone

This feature enables an SCCP phone user to view information related to the voice hunt groups and join or unjoin voice hunt groups from a menu on their phone. This feature is enabled by default. You must perform this task only if the feature was previously disabled on a phone.

Before you begin

Cisco Unified CME 10.5 or a later version.

SUMMARY STEPS

1. **enable**
2. **configure terminal**
3. **ephone *phone-tag***
4. **phone-ui voice-hunt-groups**
5. **end**

DETAILED STEPS

	Command or Action	Purpose
Step 1	enable Example: Router> enable	Enables privileged EXEC mode. <ul style="list-style-type: none"> • Enter your password if prompted.
Step 2	configure terminal Example: Router# configure terminal	Enters global configuration mode.

	Command or Action	Purpose
Step 3	ephone <i>phone-tag</i> Example: Router(config)# ephone 12	Enters ephone configuration mode. <ul style="list-style-type: none"> • <i>phone-tag</i>—Unique number that identifies this ephone during configuration tasks.
Step 4	phone-ui voice-hunt-groups Example: Router(config-ephone)# phone-ui voice-hunt-groups	Enables a SCCP phone user to view information related to voice hunt groups and also join or unjoin from voice hunt groups. <ul style="list-style-type: none"> • This command is enabled by default.
Step 5	end Example: Router(config-ephone)# end	Exits to privileged EXEC mode.

Example

The following example shows that the **voice-hunt-groups** command is enabled on an SCCP phone.

```
ephone-dn 10 dual-line
  number 1001
  no huntstop
  huntstop channel
ephone-dn 11 dual-line
```



Note From Cisco Unified CME Release 10.5 onwards, SIP phones will display voice hunt group information, by default.

Configure Service URL Button On SCCP Phone Line Key

To implement service PLK feature line key buttons on Cisco Unified SCCP Phones, perform the following steps.

SUMMARY STEPS

1. **enable**
2. **configure terminal**
3. **ephone template** *template-tag*
4. **url-button** *index type* | url [name]
5. **exit**
6. **ephone** *phone-tag*
7. **ephone-template** *template-tag*
8. **end**

DETAILED STEPS

	Command or Action	Purpose
Step 1	enable Example: Router> enable	Enables privileged EXEC mode. <ul style="list-style-type: none"> • Enter your password if prompted.
Step 2	configure terminal Example: Router# configure terminal	Enters global configuration mode.
Step 3	ephone template <i>template-tag</i> Example: Router(config)# ephone template 5	Enters ephone-template configuration mode to create an ephone template. <ul style="list-style-type: none"> • <i>template-tag</i>—Unique identifier for the ephone template that is being created. Range: 1 to 10.
Step 4	url-button <i>index type</i> url [name] Example: Router#(config-ephone-template)#url-button 1 myphoneapp Router(config-ephone-template)#url-button 2 em Router(config-ephone-template)#url-button 3 snr Router(config-ephone-template)#url-button 4 voicehuntgroups Router(config-ephone-template)#url-button 5 park-list Router(config-ephone-template)#url-button 6 http://www.cisco.com	Configures a service URL feature button on a line key. <ul style="list-style-type: none"> • <i>Index</i>—Unique index number. Range: 1 to 8. • <i>type</i>—Type of service PLK button. The following types of URL service buttons are available: <ul style="list-style-type: none"> • myphoneapp: My phone application configured under phone user interface. • em: Extension Mobility • snr: Single Number Reach • voicehuntgroups: Voice Hunt Groups Information • park-list: Parked calls • <i>url name</i>—Service URL with maximum length of 31 characters.
Step 5	exit Example: Router(config-ephone-template)# exit	Exits ephone-template configuration mode.
Step 6	ephone <i>phone-tag</i> Example: Router(config)#ephone 36	Enters ephone configuration mode. <ul style="list-style-type: none"> • <i>phone-tag</i>—Unique sequence number that identifies this ephone during configuration tasks.
Step 7	ephone-template <i>template-tag</i> Example: Router(config-ephone)# ephone-template 5	Applies an ephone template to the ephone that is being configured.

	Command or Action	Purpose
Step 8	end Example: Router(config-ephone)# end	Returns to privileged EXEC mode.

Example

The following example shows three URL buttons configured for line keys:

```

!
!
!
ephone-template 5
url-button 1 em
url-button 2 mphoneapp mphoneapp
url-button 3 snr
url-button 4 voicehuntgroups
url-button 5 park-list
!
ephone 36
ephone-template 5

```

What to do next

If you are done configuring the url buttons for phones in Cisco Unified CME, restart the phones.

Configure Service URL Button On SIP Phone Line Key

To implement service URL feature line key buttons on Cisco Unified IP Phones, perform the following steps.

SUMMARY STEPS

1. **enable**
2. **configure terminal**
3. **voice register template** *template-tag*
4. **url-button** [*index number*] [*url location*] [*label*]
5. **exit**
6. **voice register pool** *phone-tag*
7. **template** *template-tag*
8. **end**

DETAILED STEPS

	Command or Action	Purpose
Step 1	enable Example: Router> enable	Enables privileged EXEC mode. <ul style="list-style-type: none"> • Enter your password if prompted.

	Command or Action	Purpose
Step 2	configure terminal Example: Router# configure terminal	Enters global configuration mode.
Step 3	voice register template <i>template-tag</i> Example: Router(config)# voice register template 5	Enters ephone-template configuration mode to create an ephone template. <ul style="list-style-type: none"> • <i>template-tag</i>—Unique identifier for the ephone template that is being created. Range: 1 to 10.
Step 4	url-button [<i>index number</i>] [<i>url location</i>] [<i>label</i>] Example: Router(config-register-temp)url-button 1 http://x.x.x.x:80/CMEserverForPhone/vhg_root_menu VHG_List Router(config-register-temp)url-button 2 http://x.x.x.x:80/CMEserverForPhone/park_list Park_List	Configures a service url feature button on a line key. <ul style="list-style-type: none"> • x.x.x.x—CME IP address. • Index number—Unique index number ranging from 1 to 8. • URL <i>location</i>—Location of the URL. • <i>label</i>—A label name which is displayed on phone.
Step 5	exit Example: Router(config-register-temp)# exit	Exits ephone-template configuration mode.
Step 6	voice register pool <i>phone-tag</i> Example: Router(config)# voice register pool 12	Enters ephone configuration mode. <ul style="list-style-type: none"> • <i>phone-tag</i>—Unique number that identifies this ephone during configuration tasks.
Step 7	template <i>template-tag</i> Example: Router(config-register-pool)# template 5	Applies the ephone template to the phone. <ul style="list-style-type: none"> • <i>template-tag</i>—Unique identifier of the template that you created in Step 3.
Step 8	end Example: Router(config-register-pool)# end	Returns to privileged EXEC mode.

Example

The following example shows URL buttons configured in the voice register template 1:

```
Router# show run
!
voice register template 1

url-button 1 http://x.x.x.x:80/CMEserverForPhone/vhg_root_menu VHG_List
url-button 2 http://x.x.x.x:80/CMEserverForPhone/park_list Park_List
url-button 5 http://www.cisco.com Cisco
!
voice register pool 50
```

!

What to do next

If you are done configuring the URL buttons for phones in Cisco Unified CME, generate a new configuration file and restart the phones. See [Generate Configuration Profiles for SIP Phones](#).

Display Support for the Name of a Called Voice Hunt-Group

A voice hunt-group is associated with a pilot number. But because there is no association with the name of the voice hunt-group when calls are forwarded from the voice hunt-group to the final number, the forwarding number is sent without the name of the forwarding party. The final number may be in the form of a voice mail, a Basic Automatic Call Distribution (BACD) script, or another extension.

In Cisco Unified CME 9.5, the display of the name of the called voice hunt-group pilot is supported by configuring the following command in voice hunt-group or the ephone-hunt configuration mode:

```
[no] name "primary pilot name" [secondary "secondary pilot name"]
```

The secondary name is optional and when the secondary pilot name is not explicitly configured, the primary pilot name is applicable to both pilot numbers.

The following example configures the primary pilot name for both the primary and secondary pilot numbers:

```
name SALES
```

The following example configures different names for the primary and secondary pilot numbers:

```
name SALES secondary SALES-SECONDARY
```



Note Use quotes (") when input strings have spaces in between as shown in the next three examples.

The following example associates a two-word name for the primary pilot number and a one-word name for the secondary pilot number:

```
name "CUSTOMER SERVICE" secondary CS
```

The following example associates a one-word name for the primary pilot number and a two-word name for the secondary pilot number:

```
name FINANCE secondary "INTERNAL ACCOUNTING"
```

The following example associates two-word names for the primary and secondary pilot numbers:

```
name "INTERNAL CALLER" secondary "EXTERNAL CALLER"
```

For configuration information, see [Associate a Name with a Called Voice Hunt-Group, on page 74](#).

For more configuration examples, see [Example for Associating a Name with a Called Voice Hunt-Group, on page 101](#).

For configuration information, see [Configure Ephone-Hunt Groups on SCCP Phones, on page 54](#).

The following **show** commands are modified to reflect the configured primary and secondary pilot names:

- **show ephone-hunt**
- **show voice hunt-group**

The information related to the name of the ephone-hunt group and voice hunt-group are sent to the phone and displayed on the phone's user interface.



Restriction

- Display support applies to Cisco Unified SCCP IP phones in voice hunt-group and ephone-hunt configuration modes but are not supported in Cisco Unified SIP IP phones.
- Called name and called number information displayed on the caller's phone follows existing behavior, where the called names and called numbers are updated so that a sequential hunt reflects the name and number of the ringing phone.

Support for Voice Hunt Group Descriptions

In Cisco Unified CME 9.5, a description can be specified for a voice hunt group using the **description** command in voice hunt-group configuration mode.

For a configuration example, see [Example for Specifying a Description for a Voice Hunt-Group, on page 102](#).

Prevent Local Call Forwarding to the Final Agent in a Voice Hunt-Groups

Local or internal calls are calls originating from a Cisco Unified SIP or Cisco Unified SCCP IP phone in the same Cisco Unified CME system.

Before Cisco Unified CME 9.5, the **no forward local-calls** command was configured in ephone-hunt group to prevent a local call from being forwarded to the next agent.

In Cisco Unified CME 9.5, local calls are prevented from being forwarded to the final destination using the **no forward local-calls to-final** command in parallel configuration mode or the sequential voice hunt-group configuration mode.

When the **no forward local-calls to-final** command is configured in sequential voice hunt-group configuration mode, local calls to the hunt-group pilot number are sent sequentially only to the list of members of the group using the rotary-hunt technique. In case all the group members of the voice hunt group are busy, the caller hears a busy tone. If any of the group members are available but do not answer, the caller hears a ringback tone and is eventually disconnected after the specified timeout. The call is not forwarded to the final number.

When the **no forward local-calls to-final** command is configured in parallel voice hunt-group configuration mode, local calls to the hunt-group pilot number are sent simultaneously to the list of members of the group using the blast technique. In case all the group members of the voice hunt group are busy, the caller hears a busy tone. If any of the group members are available but do not answer, the caller hears a ringback tone and is eventually disconnected after the specified timeout. The call is not forwarded to the final number.

For configuration information, see [Prevent Local Call Forwarding to Final Agent in Voice Hunt-Groups, on page 76](#).

For a configuration example, see [Example for Preventing Local Call Forwarding in Parallel Voice Hunt-Groups, on page 101](#).

Enhancement of Support for Voice Hunt Group Agent Statistics

Before Cisco Unified CME Release 11.5, total logged in and total logged out time statistics were supported only for ephone hunt group agents. In Cisco Unified CME 11.5, support for Total logged in and Total logged out time statistics is added for voice hunt group agents also.

- The output of the **show voice-hunt tag statistics** command is modified to display the additional information in the statistics.

For more configuration examples, see [Example for Call Statistics From a Voice Hunt Group, on page 108](#).

Enhancement of Support for Ephone-Hunt Group Agent Statistics

Before Cisco Unified CME 9.5, statistics were maintained for each ephone hunt group and each ephone-hunt group agent. Some of the statistics included the number of maximum and minimum agents, average time to answer, average time in a call, and average time on hold.

In Cisco Unified CME 9.5, support for hunt group agent statistics of Cisco Unified SCCP IP phones is enhanced to include the following information:

- Total logged in time—On an hourly basis, displays the duration (in seconds) since a specific agent logged into a hunt group.
- Total logged out time—On an hourly basis, displays the duration (in seconds) since a specific agent logged out of a hunt group.

The output of the **show ephone-hunt tag statistics** command is modified to display the additional information in the statistics.

For more configuration examples, see [Example for Displaying Total Logged-In Time and Total Logged-Out Time for Each Hunt-Group Agent, on page 103](#).



Restriction

- Statistics collection for Cisco Unified SCCP and SIP IP phones in Cisco Unified SRST are not supported.
-

Hunt Group Agent Availability Options

Three options increase the flexibility of hunt group agents by allowing them to dynamically join and leave hunt groups or to temporarily enter a not-ready state in which they do not receive calls.

[Table 4: Comparison of Hunt Group Agent Availability Features](#), on page 24 compares the following agent availability features:

- [Dynamic Ephone Hunt Group Membership, on page 25](#)
- [Dynamically Join or Unjoin Multiple Voice Hunt Groups, on page 26](#)
- [Agent Status Control for Ephone Hunt Group, on page 27](#)
- [Agent Status Control for Voice Hunt Group, on page 28](#)
- [Automatic Agent Status Not-Ready for Ephone Hunt Group, on page 30](#)

Table 4: Comparison of Hunt Group Agent Availability Features

Comparison Factor	Dynamic Membership	Agent Status Control	Automatic Agent Status Not-Ready
Purpose	Allows an authorized agent to join and leave hunt groups.	Allows an agent to manually activate a toggle to temporarily enter a not-ready state, in which hunt-group calls bypass the agent's phone.	Automatically puts an agent's phone in a not-ready state after a specified number of hunt-group calls are unanswered by the agent's phone.
Example	Agent A joins a hunt group at 8 a.m. and takes calls until 1 p.m., when he leaves the hunt group. While Agent A is a member of the hunt group, he occupies one of the wildcard slots in the list of numbers configured for the hunt group. At 1 p.m., Agent B joins the hunt group using the same wildcard slot that Agent A relinquished when he left.	Agent A takes a coffee break at 10 a.m. and puts his phone into a not-ready status while he is on break. When he returns he puts his phone back into the ready status and immediately starts receiving hunt-group calls again. He retained his wildcard slot while he was in the not-ready status.	Agent B is suddenly called away from her desk before she can manually put her phone into the not-ready status. After a hunt-group call is unanswered at Agent B's phone, the phone is automatically placed in the not-ready status and it is not presented with further hunt-group calls. When Agent B returns, she manually puts her phone back into the ready status.
Hunt-group slot availability	An agent joining a hunt group occupies a wildcard slot in the hunt group list. An agent leaving the group relinquishes the slot, which becomes available for another agent.	An agent who enters the not-ready state does not give up a slot in the hunt group. The agent continues to occupy the slot regardless of whether the agent is in the not-ready status.	An agent who enters the not-ready does not give up a slot in the hunt group. The agent continues to occupy the slot regardless of whether the agent is in the not-ready status.
Agent activation method	An authorized agent uses a feature access code (FAC) to join a hunt group and a different FAC to leave the hunt group.	An agent uses the HLog soft key to toggle agent status between ready and not ready. Agents can also use the HLog FAC to toggle between ready and not-ready if FACs are enabled. If the HLog soft key is not enabled, the DND soft key can be used to put an agent in the not-ready status and the agent will not receive any calls.	An agent who is a member of a hunt group configured with the auto logout command does not answer the specified number of calls, and the agent's phone is automatically changed to the not-ready status. The agent uses the HLog soft key or a FAC to return to the ready status. If the HLog soft key or FAC has not been enabled in the configuration, the agent uses the DND soft key to return to the ready status.

Comparison Factor	Dynamic Membership	Agent Status Control	Automatic Agent Status Not-Ready
Configuration	The system administrator uses the list command to configure up to 20 wildcard slots in a hunt group and uses the ephone-hunt login command to authorize certain directory numbers to use these wildcard slots. See Configure Ephone-Hunt Groups on SCCP Phones, on page 54 .	The system administrator uses the HLog keyword with the hunt-group logout command to provide an HLog soft key on display phones and uses the fac command to enable standard FACs or create a custom FAC. See Configure Ephone-Hunt Groups on SCCP Phones, on page 54 .	The system administrator uses the auto logout command to enable automatic agent status not-ready for a hunt group. This functionality is disabled by default. See Configure Ephone-Hunt Groups on SCCP Phones, on page 54 . See Configure Voice-Hunt Groups, on page 63 .
Optional customizations	The system administrator can establish custom FACs for agents to use to enter or leave a hunt group.	The system administrator can use the softkeys commands to change the position or prevent the display of the HLog soft key on individual phones.	The system administrator can use the auto logout command to specify the number of unanswered calls that will trigger an agent status change to not-ready and whether this feature applies to dynamic hunt-group members, static hunt-group members, or both. The system administrator can use the hunt-group logout command to specify whether an automatic change to the not-ready status also places a phone in DND mode.

Dynamic Ephone Hunt Group Membership

Hunt groups allow you to set up pools of extension numbers to answer incoming calls. Up to 20 wildcard slots can be entered in the list of hunt group extension numbers to allow dynamic group membership, in which authorized phone users can join a hunt group whenever a vacant wildcard slot is available and they can leave when they like. Each phone user who joins a group occupies one slot. If no slots are available, a user who tries to join a group hears a busy signal.

Allowing dynamic membership in a hunt group is a three-step process:

1. Use the **list** command in ephone-hunt configuration mode to specify up to 20 wildcard slots in the hunt group.
2. Use the **ephone-hunt login** command under each directory number that should be allowed to dynamically join and leave hunt groups. Directory numbers are disallowed from joining ephone hunt groups by default, so you have to explicitly allow this behavior for each directory number that you want to be able to log in to ephone hunt groups.

- Use the **fac standard** command to enable standard FACs or the **fac custom** command to define custom FACs. FACs must be enabled so that agents can use them to join and leave ephone hunt groups.

To dynamically join an ephone hunt group, a phone user dials a standard or custom FAC for joining an ephone hunt group. The standard FAC to join an ephone hunt group is *3.

If multiple ephone hunt groups have been created that allow dynamic membership, the phone user must also dial the ephone hunt group pilot number. For example, if the following ephone hunt groups are defined, a phone user dials *38000 to join the Sales hunt group:

```
voice hunt-group 24 sequential
pilot 8000
list 8001, 8002, *, *
description Sales Group
final 9000

voice hunt-group 25 sequential
pilot 7000
list 7001, 7002, *, *
description Service Group
final 9000
```

To leave an ephone hunt group, a phone user dials the standard or custom FAC. The standard FAC to leave an ephone hunt group is #3. See [Customize Softkeys](#).



Note The Dynamic Membership feature is different from the Agent Status Control feature and the Automatic Agent Status Not-Ready feature. [Table 4: Comparison of Hunt Group Agent Availability Features](#), on page 24 compares the features.

Dynamically Join or Unjoin Multiple Voice Hunt Groups

In Cisco Unified CME 10.5 and later versions, support for phones to dynamically join the voice hunt groups is added. This feature is supported on both the SIP and SCCP phones. A single DN can dynamically join and unjoin multiple voice hunt groups. You can perform this action on a maximum of six different voice hunt groups.

A single SCCP or SIP DN can join multiple voice hunt groups dynamically by using the existing FAC standards with pilot number of voice hunt groups. A primary DN of a phone can also join and unjoin the voice hunt group using the Join or Unjoin soft key that are available on the Voice Hunt Group information display page in the My Phone App menu by using the service button.

From Cisco Unified CME Release 10.5 onwards, a status message is displayed on the SCCP phone when a dynamic agent joins a hunt group. The support for status message display for a dynamic agent joining a hunt group on the SIP phone is supported from Cisco Unified CME Release 11.6 onwards.

If a SIP or mixed shared line DN (multi-line) joins multiple voice hunt groups, the phone displays the called number information on the phone's interface for 5 seconds. For SCCP phones, the voice hunt group-related information is displayed for the primary line of the phone.

Hunt groups allow you to set up pools of extension numbers to answer incoming calls. You can enter up to 32 wildcard slots in the list of voice hunt group extension numbers to allow dynamic group membership, in which phone users can join or unjoin a voice hunt group whenever a vacant wildcard slot is available. Each

phone user who joins a group occupies one slot. If no slots are available, a user who tries to join a group will fail to join.

Allowing dynamic membership in a voice hunt group is a three-step process:

1. Use the **list** command in voice-hunt configuration mode to specify up to 32 wildcard slots in the hunt group.
2. Use the **voice-hunt-groups login** command under each directory number that should be allowed to dynamically join and unjoin hunt groups. Directory numbers are not allowed from joining voice hunt groups by default, so you have to explicitly allow this behavior for each directory number that you want to be able to join or unjoin a voice hunt groups.
3. Use the **fac standard** command to enable standard FACs or the **fac custom** command to define custom FACs. FACs must be enabled so that agents can use them to join and unjoin hunt groups.

To dynamically join a voice hunt group, a phone user dials a standard or custom FAC for joining a voice hunt group. The standard FAC to join a voice hunt group is *3.

If multiple voice hunt groups have been configured with dynamic agents, the phone user must also dial the voice hunt group pilot number. If only one voice hunt group is configured with dynamic agent, on SIP phone only FAC is sufficient. Whereas, on SCCP phone, pilot number is mandatory. For example, if the following voice hunt groups are defined, a phone user dials *38000 to join the Sales hunt group:

```
voice hunt-group 24 sequential
pilot 8000
list 8001, 8002, *, *
description Sales Group
final 9000
```

```
voice hunt-group 25 sequential
pilot 7000
list 7001, 7002, *, *
description Service Group
final 9000
```

To unjoin a voice hunt group, a phone user dials the standard or custom FAC. The standard FAC to unjoin from all the hunt groups is #3. See [Customize Softkeys](#). If a DN joins multiple voice hunt groups, then to unjoin from a specific voice hunt group the user can dial the standard FAC #4 followed by the pilot number.

From Unified CME 12.2 onwards, SIP, SCCP, and mixed (both SIP and SCCP) shared DNs can Join or Unjoin a voice hunt group dynamically.

Agent Status Control for Ephone Hunt Group

The Agent Status Control feature allows ephone hunt group agents to control whether their phones are in the ready or not-ready status. A phone in the ready status is available to receive calls from the hunt group. A phone in the not-ready status blocks calls from the hunt group. Agents should use the not-ready status for short breaks or other temporary interruptions during which they do not want to receive hunt-group calls.

Agents who put their phones into the not-ready status do not relinquish their slots in the hunt group list.

Agents use the HLog soft key or the DND soft key to put a phone into the not-ready status. When the HLog soft key is used to put a phone in the not-ready status, it does not receive hunt group calls but can receive other calls. If the DND soft key is used, the phone does not receive any calls until it is returned to the ready status. The HLog and DND soft keys toggle the feature: if the phone is in the ready status, pressing the key puts the phone in the not-ready status and vice-versa.

The DND soft key is visible on phones by default, but the HLog soft key must be enabled in the configuration using the **hunt-group logout** command, which has the following options:

- **HLog**—Enables both an HLog soft key and a DND soft key on phones in the idle, seized, and connected call states. When you press the HLog soft key, the phone is changed from the ready to not-ready status or from the not-ready to ready status. When the phone is in the not-ready status, it does not receive calls from the hunt group, but it is still able to receive calls that do not come through the hunt group (calls that directly dial its extension). The DND soft key is also available to block all calls to the phone if that is the preferred behavior.
- **DND**—Enables only a DND soft key on phones. The DND soft key also changes a phone from the ready to not-ready status or from the not-ready to ready status, but the phone does not receive any incoming calls, including those from outside hunt groups.

Phones without soft-key displays can use a FAC to toggle their status from ready to not-ready and back to ready. The **fac** command is configured under telephony-service configuration mode to enable the standard set of FACs or to create custom FACs. The standard FAC to toggle the not-ready status at the directory number (extension) level is *4 and the standard FAC to toggle the not-ready status at the ephone level (all directory numbers on the phone) is *5. See [Where to Go Next, on page 119](#).



Note The Agent Status Control feature is different from the Dynamic Membership feature and the Automatic Agent Status Not-Ready feature. [Table 4: Comparison of Hunt Group Agent Availability Features](#), on page 24 compares the features.

Agent Status Control for Voice Hunt Group

The Agent Status Control feature allows voice hunt group agents to control whether their phones are in the ready or not-ready status. A phone in the ready status is available to receive calls from the hunt group. A phone in the not-ready status blocks calls from the hunt group. Agents should use the not-ready status for short breaks or other temporary interruptions during which they do not want to receive hunt-group calls.

Agents who put their phones into the not-ready status do not relinquish their slots in the hunt group list.

Agents use the HLog softkey or the DND softkey to put a phone into the not-ready status. When the HLog softkey is used to put a phone in the not-ready status, it does not receive hunt group calls but can receive other calls. When Agent use DND button, phone will be put into Not-Ready state and Hunt group calls will not be routed. However normal or direct calls are still routed, but without audio notifications.

The DND softkey is visible on phones by default, but the HLog softkey must be enabled in the configuration using the **hunt-group logout** command, which has the following options:

- **HLog**—Enables both an HLog softkey and a DND softkey on phones in the idle, ringing, and connected call states. When you press the HLog softkey, the phone is changed from the ready to not-ready status or from the not-ready to ready status. When the phone is in the not-ready status, it does not receive calls from the hunt group, but it is still able to receive calls that do not come through the hunt group (calls that directly dial its extension). DND softkey suppresses audio notifications for direct calls.
- **DND**—Enables only a DND softkey on phones. The DND softkey also changes a phone from the ready to not-ready status or from the not-ready to ready status for voice hunt group calls. Phones receive those calls that directly dial the extension.

Phones without soft-key displays can use a FAC to toggle their status from ready to not-ready and back to ready. The **fac** command configured under telephony-service configuration mode must be used to enable the standard set of FACs or to create custom FACs. The standard FAC to toggle the not-ready status is *4 and the standard FAC to toggle the not-ready status at the phone level (all directory numbers on the phone) is *5. See [Where to Go Next, on page 119](#).

From Cisco Unified CME 10.5 onwards, SCCP and SIP phones are supported with Agent Status Control for voice hunt group. SCCP phone can log in or log out to or from voice hunt groups using HLog or DND softkeys, or standard or custom FACs, at line-Level as well as phone level. Whereas, SIP phones can log in or log out to or from voice hunt groups using only standard or custom FACs, only at Line-Level.

From Cisco Unified CME Release 11.6 onwards, SIP phones are also supported with agent status control, for voice hunt groups with HLog softkeys or FAC. Hence, SIP phones can logout or login to voice hunt group using HLog softkey, feature button, or FAC at phone level. If the phone is configured with a single line or multiple lines, and if these lines are members of a voice hunt group, then phone level logout or login results in logout or login of all lines on the phone.

To make HLog functionality work with the SIP or SCCP phones, you need to configure the command **hunt-group logout HLog** under telephony-service. Once user is logged out from the hunt group, phone displays a message stating that the user is logged out of hunt group. When the user is logged in to hunt group, the agent phone displays a message stating that the user is logged in to hunt group. For Unified CME 12.1 and earlier releases, if any directory number that is part of voice hunt group is shared across phones, then logout is not allowed at the phone level.

For Unified CME 12.2 and later releases, if any directory number that is part of voice hunt group is a shared-line, then logout is allowed for all lines at the phone level, except the shared-line. Shared-line status (always in logged-in state) in a voice hunt group cannot be toggled using agent status control functionality. While SCCP phones with a mixed shared-line only support line level logout of the phone lines (except the shared-line), SIP phones with a mixed shared-line support phone level logout of the phone lines (except the shared-line).

To enable FAC, you need to configure standard or custom FAC under telephony service configuration mode using the command **fac standard** or **fac custom**.

SIP and SCCP phone behavior is different for the following scenarios:

- If phone dn's are not members of a hunt group and phone is configured with an HLog feature button, then phone LED is off for SIP phones and on for SCCP phones.
- If a SIP phone is already in logged in state, any newly joining dn of that phone (in any voice hunt group) is automatically in logged in state.
- If a SIP phone is already in logged out state, any newly joining dn of that phone (in any voice hunt group) is automatically in logged out state.
- Irrespective of whether the SCCP phone is in logged out or logged in state, any dn of that phone joining any voice hunt group retains its previous state (logged out or logged in). For example, if dn 8002 is member of voice hunt group 1 in logged out state, then 8002 remains in logged out state on joining voice hunt group 2. If dn 8001 on the same phone (which was not part of any hunt group) joins any voice hunt group, it is in logged in state.



Note From Cisco Unified CME Release 11.6 onwards, line level logout or login using FAC *4 is not supported for SIP phones (only supported on SCCP phones). SIP phones only support phone level logout or login using FAC *5.

Use **hlog-block** command under **voice hunt-group** for Agent Status Control. If you enable this command under **voice hunt-group**, the logout or login functionality for voice hunt-group is disabled. For example, you can use **hlog-block** command in voice hunt-groups where logout or login functionality using HLog softkey (or by using FAC) needs to be restricted. By default, **hlog-block** command is disabled.



Note The Agent Status Control feature is different from the Dynamic Membership feature and the Automatic Agent Status Not-Ready feature. [Table 4: Comparison of Hunt Group Agent Availability Features](#), on page 24 compares the features.

Members Logout for Ephone Hunt Group

All members configured under an ephone-hunt are initialized with HLogin by default. The non-shared static members or agents in an ephone hunt group can be configured with the Hlogout initial state using the Members Logout feature. You can use the CLI command **members logout** configured under ephone-hunt configuration mode to enable the feature. From Cisco Unified CME Release 9.1, members logout is supported for ephone hunt groups.

Members logout cannot be used for shared DNs. Also, this feature is not supported if the CLI commands **list** and **hunt-group logout DND** are configured.

Members Logout for Voice Hunt Group

All members configured in a voice hunt group are initialized with HLogin by default. The non-shared static members or agents in a voice hunt group can be configured with the Hlogout initial state using members logout functionality. You can use the CLI command **members logout** configured under voice hunt group configuration mode to enable the feature. From Cisco Unified CME Release 11.6, members logout is supported in voice hunt groups.

If any member of a hunt group in a SIP phone logs out using the CLI command **members logout**, all other DN's of that phone in any hunt group are also logged out. This is because SIP phones only support phone level logout. For SCCP phones, only the DN that is configured with the CLI command **members logout** is logged out from the hunt group. Other member DN's do not logout as SCCP phones support line level logout.

Members logout cannot be used for shared DNs. The feature is not supported if the CLI command **hunt-group logout DND** is configured. Also, you cannot configure the CLI command **members logout** if the command **list** is configured.

Automatic Agent Status Not-Ready for Ephone Hunt Group

Before Cisco Unified CME 4.0, this feature was known as Automatic Hunt Group Logout. If the **auto logout** command was enabled for a hunt group, a phone was placed in DND mode when a line on the phone did not answer a call for that hunt group within the time limit specified in the **timeout** command.

In Cisco Unified CME 4.0 and later versions, the name and behavior of this feature has changed, although the Cisco IOS command remains the same. The **auto logout** command now specifies the number of unanswered hunt group calls after which the agent status of a directory number is automatically changed to not-ready. You can limit Automatic Agent Status Not-Ready to dynamic hunt group members (those who log in using a wildcard slot in the **list** command) or to static hunt group members (those who are explicitly named in the **list** command), or you can apply this behavior to all hunt group members.

A related command, **hunt-group logout**, specifies whether the phones that are automatically changed to the not-ready status should also be placed into DND mode. Phones in the not-ready status do not accept calls

from hunt groups, but they do accept calls that directly dial their extensions. Phones in DND mode do not accept any calls. The default if the **hunt-group logout** command is not used is that the phones that are automatically placed in the not-ready status are also placed in DND mode.

Agents whose phones are automatically placed into the not-ready status do not relinquish their slots in the hunt group list.



Note The Automatic Agent Status Not-Ready feature is different from the Dynamic Membership feature and the Agent Status Control feature. [Table 4: Comparison of Hunt Group Agent Availability Features](#), on page 24 compares the features.

Automatic Agent Status Not-Ready for Voice Hunt Group

From Cisco Unified CME Release 11.6, Automatic Hunt Group Logout is supported on voice hunt groups. If the **auto logout** CLI command is enabled for a hunt group, it specifies the number of successive unanswered hunt group calls after which the agent status of a directory number is automatically changed to not-ready. The range for the number of unanswered rings configured under **auto logout** command is 1 to 20. If auto logout is not configured with any value, the default value of 1 is applied.

When the **auto logout** command is enabled under voice hunt group, the auto logout behavior applies to all hunt group members (including static and dynamic members).

A related command, **hunt-group logout**, specifies whether the phones are automatically changed to the not-ready status. Phones in the not-ready state do not accept calls from hunt groups, but they do accept calls that directly dial their extensions.

If **hunt group logout HLog** is configured, then the DN's of that hunt group will go to logout state when the number of unanswered rings specified under **auto logout** command is exceeded. If **hunt group logout DND** is configured, then phone goes to DND mode and logs out the DND member when the number of unanswered rings specified under **auto logout** command is exceeded. If any hunt group members are logged out, they can use HLog Softkey, FAC, Feature Button, or DND softkey to login again.

Agents whose phones are automatically placed into the not-ready status do not relinquish their slots in the hunt group list. When an agent returns to ready status, the voice hunt group resumes sending calls to the agent's DN.

Consider a voice hunt group in sequential, peer, or longest idle configuration mode with call hunt in progress. Then, auto logout count is incremented for agents who do not answer the call. The auto logout count is not incremented for agents who answer the call. In this scenario, the agent can be either an SCCP DN or a SIP DN.

Consider a voice hunt group in parallel configuration mode with call blast in progress to all logged in DN's in the hunt group. If call is answered by any of the agents, then the remaining agents in that hunt group will not have auto logout count incremented. However, if call is not answered by any of the agents, then the auto logout count will be incremented for all the logged in agents. Here, agent can be either a SCCP DN or SIP DN.



Note The Automatic Agent Status Not-Ready feature is different from the Dynamic Membership feature and the Agent Status Control feature. [Table 4: Comparison of Hunt Group Agent Availability Features](#), on page 24 compares the features.

All Agents Logged Out Display on SIP Phones

From Unified CME 12.2 release, **All agents logged out** status message is displayed on SIP phones. The feature is supported on Cisco 8800 Series IP Phones for Unified CME on Cisco 4000 Series Integrated Services Routers. For example, consider a voice hunt group with three directory numbers (DN) 4002, 4003, and 4004, configured in three different IP phones. When the last member of the voice hunt group is logged out, the message, **All agents logged out** displays at the line level for all the members in the hunt group. If one of the DNs in the voice hunt group with all members logged out has call forward all enabled as well, then the line level display on the phone toggles between the **All agents logged out** and the **Forwarded to directory number** messages. The duration of message display before toggling is 1.5 seconds. Localization is supported for the All Agents Logged Out Display on SIP Phones. For more information, see the figure.

Figure 6: All Agents Logged Out Message on SIP Phones

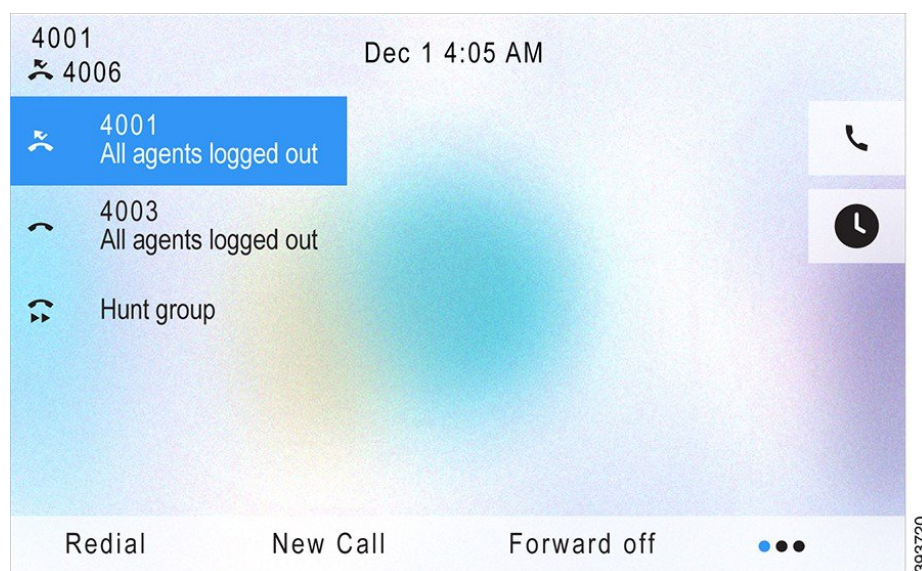

Presentation of Calls for Ephone Hunt Group

For phones configured under ephone hunt group configuration mode, presentation of calls is supported using the CLI command, **present-call**. When the CLI command is configured, calls from the ephone hunt group are presented only if all lines are on hook or in idle state.

If you configure **idle-phone** as the sub-mode option of the CLI command **present-call**, calls from the ephone-hunt group are presented only if all lines are idle on the phone on which the hunt-group line appears. This option does not consider monitored lines that have been configured on the phone using the **button m** command.

If you configure **onhook-phone** as the sub-mode option of the CLI command **present-call**, calls from the ephone-hunt group are presented only if the phone on which the number appears is in onhook state. When this keyword is configured, calls in the ringing or hold state that are unrelated to the hunt group do not prevent the presentation of calls from the ephone-hunt group.

Presentation of Calls for Voice Hunt Group

For phones configured under voice hunt group configuration mode, presentation of calls is supported using the CLI command **present-call**. The feature is supported from Cisco Unified CME Release 11.6 onwards.

When the **present-call** CLI command is configured, calls from the voice hunt group are presented only if all lines are idle on the phone on which the hunt group line appears.

If the **present-call** CLI command is not configured, voice hunt group calls are presented without considering the status of other phone lines on the phone. Hence, voice hunt group presents calls to an ephone or voice register pool whenever the phone line (ephone-dn or voice register dn) that corresponds to a number in a voice hunt group list is available. Hence, when you configure the **present-call** CLI command, you get the additional control to ensure that hunt group calls do not possibly go unanswered.

Night Service

The night-service feature allows you to provide coverage for unstaffed extensions during hours that you designate as “night-service” hours. During the night-service hours, calls to the designated extensions, known as night-service directory numbers or night-service lines, send a special “burst” ring (for SCCP phones and SIP phones) to night-service phones that have been specified to receive this special ring. Phone users at the night-service phones can then use the call-pickup feature to answer the incoming calls from the night-service directory numbers.

For example, the night-service feature can allow an employee working after hours to intercept and answer calls that are presented to an unattended receptionist’s phone. This feature is useful for sites at which all incoming public switched telephone network (PSTN) calls have to be transferred by a receptionist. This is because all the Direct Inward Dialing (DID) calls are not published to PSTN for Cisco Unified CME system. When a call arrives at the unattended receptionist’s phone during hours that are specified as night service, a ring burst notifies a specified set of phones of the incoming call. A phone user at any of the night-service phones can intercept the call using the call-pickup feature. Night-service call notification is sent every 12 seconds until the call is either answered or aborted.

A user can enter a night-service code to manually toggle night-service treatment off and on from any phone that has a line assigned to night service. Before Cisco CME 3.3, using the night-service code turns night service on or off only for directory numbers on the phone at which the code is entered. In Cisco CME 3.3 and later versions, using the night-service code at any phone with a night-service directory number turns night service on or off for all phones with night-service directory numbers. From Unified CME 11.5 onwards, night service feature is supported on SIP phones along with SCCP phones.

Mixed deployment of SIP and SCCP phones is supported from Cisco Unified CME Release 11.6. Any combination of SIP and SCCP phones are supported across incoming call, unstaffed DNs, and agent phones. For DNs in which night service is enabled, notifications are sent to both SIP and SCCP phones that are designated as night service agents in a mixed deployment.

[Figure 7: Night Service for SCCP Phones, on page 34](#) illustrates night service for SCCP phones.

Figure 7: Night Service for SCCP Phones

- ① Extension 1000 has been designated as a night-service extension (ephone-dn). When extension 1000 receives an incoming call during a night-service period, phone 5 rings and notification is made to the night-service phones.
- ② Phones 14 and 15 have been designated as night-service phones. When phone 5 starts ringing, phones 14 and 15 ring once and display 'Night Service 1000.' The incoming call on extension 1000 can be answered from phone 14 or phone 15 using call pickup.

```
telephony-service
  night-service day fri 17:01 17:00
  night-service day sat 17:01 17:00
  night-service day sun 17:01 07:59
  night-service date jan 1 00:00 00:00
  night-service code *1234
!
ephone-dn 1
  number 1000
  night-service bell
!
ephone-dn 10
  number 1010
!
ephone-dn 11
  number 1011
!
ephone 5
  mac-address 1111.2222.0001
  button 1:1
!
ephone 14
  mac-address 1111.2222.0002
  button 1:10
  night-service bell
!
ephone 15
  mac-address 1111.2222.0003
  button 1:11
  night-service bell
```

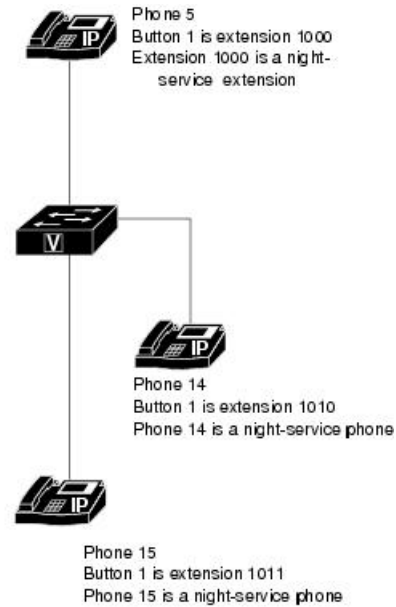

158

Figure 8: Night Service for SIP Phones, on page 35 illustrates night service for SIP phones.

Figure 8: Night Service for SIP Phones

- ① Extension 1000 has been designated as a night-service extension. When extension 1000 receives an incoming call during a night-service period, phone 5 rings and notification is made to the night-service phones.
- ② Phones 14 and 15 have been designated as night-service phones. When phone 5 starts ringing, phones 14 and 15 ring once and display "Night Service 1000." The incoming call on extension 1000 can be answered from phone 14 or phone 15 using gpickup functionality.

```
telephony-service
night-service day fri 17:01 17:00
night-service day sat 17:01 17:00
night-service day sun 17:01 07:59
night-service date jan 1 00:00 00:00
night-service code *1234
service directed-pickup gpickup
call-park system application
timeouts night-service-bell 10
!
voice register dn 1
number 1000
night-service bell
!
voice register dn 10
number 1010
!
voice register dn 11
number 1011
!
voice register pool 5
mac-address 1111.2222.0001
type 8851
number 1 dn 1000
!
voice register pool 14
mac-address 1111.2222.0002
type 8851
number 10 dn 1010
night-service bell
!
voice register pool 15
mac-address 1111.2222.0003
type 8851
number 11 dn 1011
night-service bell
```

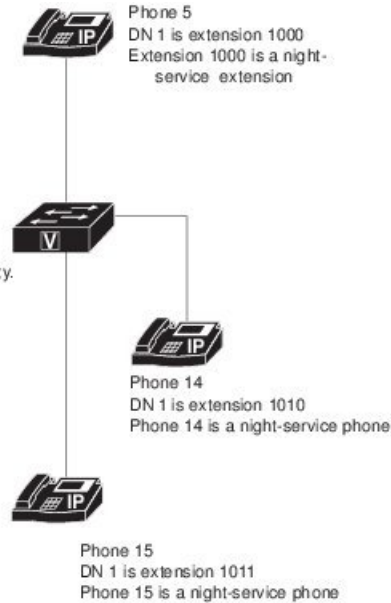

303087

Overlaid Ephone-dns

Overlaid ephone-dns are directory numbers that share the same button on a phone. Overlaid ephone-dns can be used to receive incoming calls and place outgoing calls. Up to 25 ephone-dns can be assigned to a single phone button. They can have the same extension number or different numbers. The same ephone-dns can appear on more than one phone and more than one phone can have the same set of overlaid ephone-dns.

The order in which overlaid ephone-dns are used by incoming calls can be determined by the call hunt commands, **preference** and **huntstop**. For example, ephone-dn 1 to ephone-dn 4 have the same extension number, 1001. Three phones are configured with the **button 1o1,2,3,4** command. A call to 1001 will ring on the ephone-dn with the highest preference and display the caller ID on all phones that are on hook. If another incoming call to 1001 is placed while the first call is active (and the first ephone-dn with the highest preference is configured with the **no huntstop** command), the second call will roll over to the ephone-dn with the next-highest preference, and so forth. For more information, see [Call Hunt, on page 4](#).

If the ephone-dns in an ephone-dn overlay use different numbers, incoming calls go to the ephone-dn with the highest preference. If no preferences are configured, the **dial-peer hunt** command setting is used to determine which ephone-dns are used for incoming calls. The default setting for the **dial-peer hunt** command is to randomly select an ephone-dn that matches the called number.



Note To continue or to stop the search for ephone-dns, you must use, respectively, the **no huntstop** and **huntstop** commands under the individual ephone-dns. The huntstop setting is applied only to the dial peers affected by the **ephone-dn** command in telephony-service mode. Dial peers configured in global configuration mode comply with the global configuration huntstop setting.

Figure 9: Overlaid Ephone-dn (Simple Case), on page 36 shows an overlay set with two directory numbers and one number that is shared on two phones. Ephone-dn 17 has a default preference value of 0, so it will receive the first call to extension 1001. The phone user at phone 9 answers the call, and a second incoming call to extension 1001 can be answered on phone 10 using directory number 18.

Figure 9: Overlaid Ephone-dn (Simple Case)

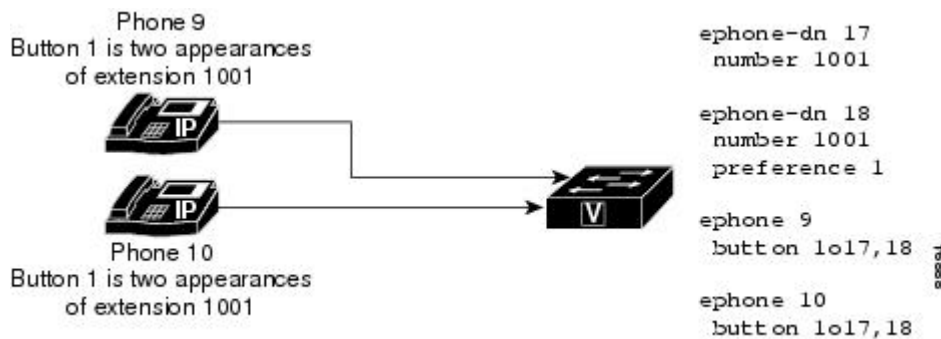

When a call is answered on an ephone-dn, that ephone-dn is no longer available to other phones that share the ephone-dn in overlay mode. For example, if extension 1001 is answered by phone 1, caller ID for extension 1001 displays on phone 1 and is removed from the screens of phone 2 and phone 3. All actions pertaining to the call to extension 1001 (ephone-dn 17) are displayed on phone 1 only. If phone 1 puts extension 1001 on hold, the other phones will not be able to pick up the on-hold call using a simple shared-line pickup. In addition, none of the other four phones will be able to make outgoing calls from the ephone-dn while it is in use. When phone users press button 1, they will be connected to the next available ephone-dn listed in the **button** command. For example, if phone 1 and phone 2 are using ephone-dn 1 and ephone-dn 2, respectively, phone 3 must pick up ephone-dn 3 for an outgoing call.

If there are more phones than ephone-dns associated with an ephone-dn overlay set, it is possible for some phones to find that all the ephone-dns within their overlay set are in use by other phones. For example, if five phones have a line button configured with the **button 1o1, 2, 3** command, there may be times when all three of the ephone-dns in the overlay set are in use. When that occurs, the other two phones will not be able to use an ephone-dn in the overlay set. When all ephone-dns in an overlay set are in use, phones with this overlay set will display the remote-line-in-use icon (a picture of a phone with a flashing X through it) for the corresponding line button. When at least one ephone-dn becomes available within the overlay set (that is, an ephone-dn is either idle or ringing), the phone display reverts to showing the status of the available ephone-dn (idle or ringing).

Shared- Line Overlays

Dual-line ephone-dns can also use overlays. The configuration parameters are the same as for single-line ephone-dns, except that the **huntstop channel** command must be used to keep calls from hunting to the ephone-dn's second channel.

The primary ephone-dn in a shared-line overlay set should be unique to the phone to guarantee that the phone has a line available for outgoing calls, and to ensure that the phone user can obtain dial-tone even when there are no idle lines available in the rest of the shared-line overlay set. Use a unique ephone-dn to provide for a unique calling party identity on outbound calls made by the phone so that the called user can see which specific phone is calling.

The following example shows the configuration for a simple shared-line overlay set. The primary ephone-dn that is configured for each phone is unique while the remaining ephone-dns 10, 11, and 12 are shared in the overlay set on both phones.

```
ephone 1
  mac-address 1111.1111.1111
  button 1o1,10,11,12
!
ephone 2
  mac-address 2222.2222.2222
  button 1o2,10,11,12
```

A more complex directory number configuration mixes overlaid directory numbers with shared directory numbers and plain dual-line directory numbers on the same phones. [Figure 10: Overlaid Ephone-dn \(Complex Case\), on page 38](#) illustrates the following example of a manager with two assistants. On the manager's phone the same number, 2001, appears on button 1 and button 2. The two line appearances of extension 2001 use two single-line directory numbers, so the manager can have two active calls on this number simultaneously, one on each button. The directory numbers are set up so that button 1 will ring first, and if a second call comes in, button 2 will ring. Each assistant has a personal directory number and also shares the manager's directory numbers. Assistant 1 has all three directory numbers in an overlay set on one button, whereas assistant 2 has one button for the private line and a second button with both of the manager's lines in an overlay set. A sequence of calls might be as follows.

1. An incoming call is answered by the manager on extension 2001 on button 1 (directory number 20).
2. A second call rings on 2001 and rolls over to the second button on the manager's phone (directory number 21). It also rings on both assistants' phones, where it is also directory number 21, a shared directory number.
3. Assistant 2 answers the call. This is a shared overlay line (one directory number, 21, is shared among three phones, and on two of them this directory number is part of an overlay set). Because it is shared with button 2 on the manager's phone, the manager can see when assistant 2 answers the call.
4. Assistant 1 makes an outgoing call on directory number 22. The button is available because of the additional directory numbers in the overlay set on the assistant 1 phone.

At this point, the manager is in conversation on directory number 20, assistant 1 is in conversation on directory number 22, and assistant 2 is in conversation on directory number 21.

Figure 10: Overlaid Ephone-dn (Complex Case)

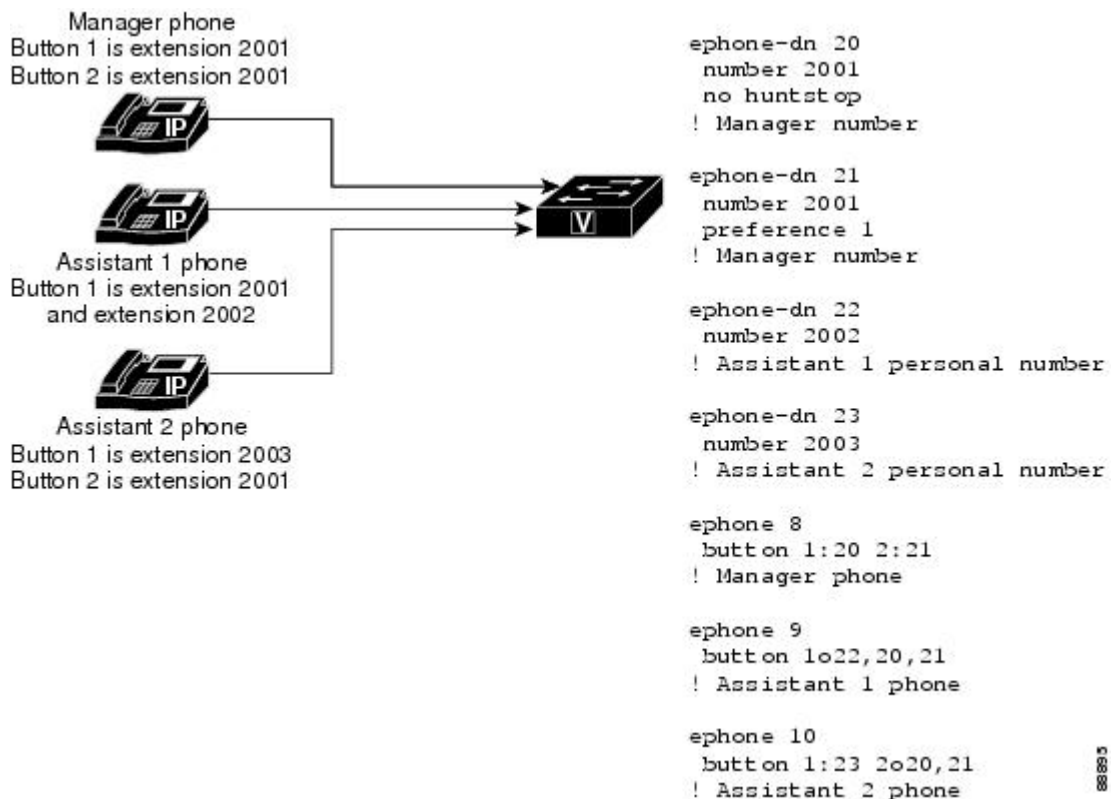

For configuration information, see [Configure Overlaid Ephone-dns on SCCP Phones, on page 89](#).

Call Waiting for Overlaid Ephone-dns

Call waiting allows phone users to know that another person is calling them while they are talking on the phone. Phone users hear a call-waiting tone indicating that another party is trying to reach them. Calls to IP phones with soft keys can be answered with the Answer soft key. Calls to analog phones are answered using hookflash. When phone users answer a call-waiting call, their original call is automatically put on hold. If phone users ignore a call-waiting call, the caller is forwarded if call-forward no-answer has been configured.

In Cisco CME 3.2.1 and later versions, call waiting is available for overlaid ephone-dns. The difference in configuration between overlaid ephone-dns with call waiting and overlaid ephone-dns without call waiting is that overlaid ephone-dns with call waiting use the `c` keyword in the `button` command and overlaid ephone-dns without call waiting use the `o` keyword. For configuration information, see [Configure Overlaid Ephone-dns on SCCP Phones, on page 89](#).

The behavior of overlaid ephone-dns with call waiting and overlaid ephone-dns without call waiting is the same, except for the following:

- Calls to numbers included in overlaid ephone-dns with call waiting will cause inactive phones to ring and active phones connected to other parties to generate auditory call-waiting notification. The default sound is beeping, but you can configure an ephone-dn to use a ringing sound. (See [Configure Call-Waiting Indicator Tone on SCCP Phone, on page 48](#).) Visual call-waiting notification includes the blinking of handset indicator lights and the display of caller IDs.

For example, if three of four phones are engaged in calls to numbers from the same overlaid ephone-dn with call-waiting and another call comes in, the one inactive phone will ring, and the three active phones will issue auditory and visual call-waiting notification.

- In Cisco Unified CME 4.0 and later versions, up to six waiting calls can be displayed on Cisco Unified IP Phone 7940G, 7941G, 7941G-GE, 7960G, 7961G, 7961G-GE, 7970G, and 7971G-GE. For all other phones and earlier Cisco Unified CME versions, two calls to numbers in an overlaid ephone-dn set can be announced. Subsequent calls must wait in line until one of the two original calls has ended. The callers who are waiting in the line will hear a ringback tone.

For example, a Cisco Unified IP Phone 7910 (maximum two call-waiting calls) has a button configured with a set of overlaid ephone-dns with call waiting (**button 1c1,2,3,4**). A call to ephone-dn 1 is answered. A call to ephone-dn 2 generates call-waiting notification. Calls to ephone-dn 3 and ephone-dn 4 will wait in line and remain invisible to the phone user until one of the two original calls ends. When the call to ephone-dn 1 ends, the phone user can then talk to the person who called ephone-dn 2. The call to ephone-dn 3 issues call-waiting notification while the call to ephone-dn 4 waits in line. (The Cisco Unified IP Phone 7960 supports six calls waiting.) Phones configured for call waiting do not generate call-waiting notification when they are transferring calls or hosting conference calls.

Note that if an overlaid ephone-dn has call-forward-no-answer configured, calls to the ephone-dn that are unanswered before the no-answer timeout expires are forwarded to the configured destination. If call-forward-no-answer is not configured, incoming calls receive ringback tones until the calls are answered.

More than one phone can use the same set of overlaid ephone-dns. In this case, the call-waiting behavior is slightly different. The following example demonstrates call waiting for overlaid ephone-dns that are shared on two phones:

```
ephone 1
button 1c1,2,3,4
!
ephone 2
button 1c1,2,3,4
```

1. A call to ephone-dn 1 rings on ephone 1 and on ephone 2. Ephone 1 answers, and the call is no longer visible to ephone 2.
2. A call to ephone-dn 2 issues a call-waiting notification to ephone 1 and rings on ephone 2, which answers. The second call is no longer visible to ephone 1.
3. A call to ephone-dn 3 issues a call-waiting notification to ephone 1 and ephone 2. Ephone 1 puts the call to ephone-dn 1 on hold and answers the call to ephone-dn 3. The call to ephone-dn 3 is no longer visible to ephone 2.
4. A call to ephone-dn 4 issues a call-waiting notification on ephone 2. The call is not visible on ephone 1 because it has met the two-call maximum by handling the calls to ephone-dn 1 and ephone-dn 3. (Note that the call maximum is six for those phones that are able to handle six call-waiting calls, as previously described.)



Note Ephone-dns accept call interruptions, such as call waiting, by default. For call waiting to work, the default must be active. For more information, see [Configure Call-Waiting Indicator Tone on SCCP Phone, on page 48](#).

Extend Calls for Overlaid Ephone-dns to Other Buttons on the Same Phone

Phones with overlaid ephone-dns can use the **button** command with the **x** keyword to dedicate one or more additional buttons to receive overflow calls. If an overlay button is busy, an incoming call to any of the other ephone-dns in the overlay set rings on the first available overflow button on each phone that is configured to receive the overflow. This feature works only for overlaid ephone-dns that are configured with the **button** command and the **o** keyword; it is not supported with overlaid ephone-dns that are configured using the **button** command and the **c** keyword or other types of ephone-dns that are not overlaid.

Using the **button** command with the **c** keyword results in multiple calls on one button (the button is overlaid with multiple ephone-dns that have call waiting), whereas using the **button** command with the **o** keyword and the **x** keyword results in one call per button and calls on multiple buttons.

For example, an ephone has an overlay button with ten numbers assigned to it using the **button** command and the **o** keyword. The next two buttons on the phone are configured using the **button** command and the **x** keyword. These buttons are reserved to receive additional calls to the overlaid extensions on the first button when the first button is in use.

```
ephone 276
  button 1024,25,26,27,28,29,30,31,32,33 2x1 3x1
```

For configuration information, see [Configure Overlaid Ephone-dns on SCCP Phones, on page 89](#).

Configure Call Coverage Features

Configure Call Hunt on SCCP Phones

To configure a group of directory numbers to provide call coverage for a single called number, perform the following steps for each directory number in the group.

SUMMARY STEPS

1. **enable**
2. **configure terminal**
3. **ephone-dn** *dn-tag* [**dual-line**]
4. **number** *number* [**secondary** *number*] [**no-reg** [**both** | **primary**]]
5. **preference** *preference-order* [**secondary** *secondary-order*]
6. **no huntstop** or **huntstop**
7. **huntstop channel**
8. **end**

DETAILED STEPS

	Command or Action	Purpose
Step 1	enable Example: Router> enable	Enables privileged EXEC mode. <ul style="list-style-type: none"> • Enter your password if prompted.

	Command or Action	Purpose
Step 2	configure terminal Example: <pre>Router# configure terminal</pre>	Enters global configuration mode.
Step 3	ephone-dn dn-tag [dual-line] Example: <pre>Router(config)# ephone-dn 20 dual-line</pre>	Enters ephone-dn configuration mode for the purpose of configuring a directory number.
Step 4	number number [secondary number] [no-reg [both primary]] Example: <pre>Router(config-ephone-dn)# number 101</pre>	Associates a telephone or extension number with the directory number. <ul style="list-style-type: none"> Assign the same number to several primary or secondary ephone-dns to create a group of virtual dial peers through which the incoming called number must search.
Step 5	preference preference-order [secondary secondary-order] Example: <pre>Router(config-ephone-dn)# preference 2</pre>	Sets the preference value for the ephone-dn. <ul style="list-style-type: none"> Default: 0. Increment the preference order for subsequent ephone-dns with the same number. That is, the first directory number is preference 0 by default and you must specify 1 for the second ephone-dn with the same number, 2 for the next, and so on. secondary secondary-order—(Optional) Preference value for the secondary number of an ephone-dn. Default is 9.
Step 6	no huntstop or huntstop Example: <pre>Router(config-ephone-dn)# no huntstop</pre> or <pre>Router(config-ephone-dn)# huntstop</pre>	Explicitly enables call hunting behavior for a directory number. <ul style="list-style-type: none"> Configure no huntstop for all ephone-dns, <i>except</i> the final ephone-dn, within a set of ephone-dns with the same number. Configure the huntstop command for the final ephone-dn within a set of ephone-dns with the same number.
Step 7	huntstop channel Example: <pre>Router(config-ephone-dn)# huntstop channel</pre>	(Optional) Enables channel huntstop, which keeps a call from hunting to the next channel of a directory number if the first channel is busy or does not answer. <ul style="list-style-type: none"> Required for dual-line ephone-dns that are used for call hunting.
Step 8	end Example:	

Command or Action	Purpose
Router(config-ephone-dn) # end	

What to do next

If you want to collect statistics for hunt groups, see [Cisco Unified CME B-ACD and Tcl Call-Handling Applications](#).

Verify Call Hunt Configuration on SCCP Phones

To verify the configuration for call hunt, perform the following steps.

SUMMARY STEPS

1. **show running-config**
2. **show telephony-service ephone-dn**
3. **show telephony-service all** or **show telephony-service dial-peer**

DETAILED STEPS

Step 1 **show running-config**

This command displays your configuration. Preference and huntstop information is listed in the ephone-dn portion of the output.

```
Router# show running-config
```

```
ephone-dn 2 dual-line
number 126
description FrontDesk
name Receptionist
preference 1
call-forward busy 500
huntstop channel
no huntstop
```

Step 2 **show telephony-service ephone-dn**

This command displays ephone-dn preference and huntstop configuration information.

Step 3 **show telephony-service all** or **show telephony-service dial-peer**

These commands display preference and huntstop configurations for ephone-dn dial peers.

```
Router# show telephony-service dial-peer
```

```
!
```

```
dial-peer voice 20026 pots
destination-pattern 5002
huntstop
call-forward noan 5001 timeout 45
port 50/0/2
```

Configure Call Hunt on SIP Phones

To configure the call hunting feature and prevent hunt-on-busy from redirecting a call from a busy phone into a dial peer that has been setup with a catch-all default destination, perform the following steps.

SUMMARY STEPS

1. **enable**
2. **configure terminal**
3. **voice register dn** *dn-tag*
4. **number** *number*
5. **preference** *preference-order*
6. **huntstop**
7. **end**

DETAILED STEPS

	Command or Action	Purpose
Step 1	enable Example: Router> enable	Enables privileged EXEC mode. <ul style="list-style-type: none"> • Enter your password if prompted.
Step 2	configure terminal Example: Router# configure terminal	Enters global configuration mode.
Step 3	voice register dn <i>dn-tag</i> Example: Router(config)# voice register dn 1	Enters voice register dn configuration mode to define a directory number for a SIP phone, intercom line, voice port, or an MWI.
Step 4	number <i>number</i> Example: Router(config-register-dn)# number 5001	Associates a phone number with the directory number. <ul style="list-style-type: none"> • Assign the same number to several directory numbers to create a group of virtual dial peers through which the incoming called number must search.

	Command or Action	Purpose
Step 5	preference <i>preference-order</i> Example: Router(config-register-dn)# preference 4	Creates the preference order for matching the VoIP dial peers created for the number associated with this directory number to establish the hunt strategy for incoming calls. <ul style="list-style-type: none"> • Default is 0, which is the highest preference.
Step 6	huntstop Example: Router(config-register-dn)# huntstop	Disables call-hunting behavior for an extension on a SIP phone.
Step 7	end Example: Router(config-register-dn)# end	Exits configuration mode and enters privileged EXEC mode.

What to do next

If you want to collect statistics for hunt groups, see [Cisco Unified CME B-ACD and Tcl Call-Handling Applications](#).

Enable Call Pickup

To enable Call Pickup features on SCCP or SIP phones, perform the following steps.



Restriction

- SIP phones that do not support the Pickup and Gpickup soft keys must use feature access codes (FACs) to access these features.
- Different directory numbers with the same extension number must have the same Pickup configuration.
- A directory number can be assigned to only one pickup group.
- Pickup group numbers can vary in length, but must have unique leading digits. For example, if you configure group number 17, you cannot also configure group number 177. Otherwise a pickup in group 17 is always triggered before the user can enter the final 7 for 177.
- Calls from H.323 trunks are not supported on SIP phones.

Before you begin

It is mandatory to configure the CLI command **call-park system application** under telephony-service to enable or disable Call Pickup functionality using call pickup feature on SIP phones.

- SIP phones require Cisco Unified CME 7.1 or a later version.
- The Pickup and GPickUp soft keys display by default on supported SCCP and SIP phones. If previously disabled, you must enable these soft keys with the **softkeys idle** command.

SUMMARY STEPS

1. **enable**
2. **configure terminal**
3. **telephony-service**
4. **call-park system application**
5. **service directed-pickup [gpickup]**
6. **fac {standard | custom pickup {direct | group | local} custom-fac}**
7. **exit**
8. **ephone-dn dn-tag [dual-line | octo-line]** or **voice register dn dn-tag**
9. **pickup-group group-number**
10. **pickup-call any-group**
11. **end**

DETAILED STEPS

	Command or Action	Purpose
Step 1	enable Example: Router> enable	Enables privileged EXEC mode. <ul style="list-style-type: none"> • Enter your password if prompted.
Step 2	configure terminal Example: Router# configure terminal	Enters global configuration mode.
Step 3	telephony-service Example: Router(config)# telephony-service	Enters telephony-service configuration mode.
Step 4	call-park system application Example: Router(config-telephony)# call-park system application	Enables or disables Call Pickup functionality using call pickup feature on SIP phones.
Step 5	service directed-pickup [gpickup] Example: Router(config-telephony)# service directed-pickup gpickup	Enables Directed Call Pickup and modifies the function of the GPickUp and Pickup soft keys. <ul style="list-style-type: none"> • gpickup—(Optional) Enables using the GPickUp soft key to perform Directed Call Pickup on SCCP phones. This keyword is supported in Cisco Unified CME 7.1 and later versions. • This command determines the specific soft keys used to access different Call Pickup features on SCCP and SIP phones. For a description, see the service directed-pickup command in the Cisco Unified CME Command Reference.

	Command or Action	Purpose
Step 6	<p>fac { standard custom pickup { direct group local } <i>custom-fac</i> }</p> <p>Example:</p> <pre>Router(config-telephony)# fac custom pickup group #35</pre>	<p>Enables standard FACs or creates a custom FAC or alias for Pickup features on SCCP and SIP phones.</p> <ul style="list-style-type: none"> • standard—Enables standard FACs for all phones. Standard FAC for Park Retrieval is **10. • custom—Creates a custom FAC for a feature. • <i>custom-fac</i>—User-defined code to dial using the keypad on an IP or analog phone. Custom FAC can be up to 256 characters and contain numbers 0 to 9 and * and #.
Step 7	<p>exit</p> <p>Example:</p> <pre>Router(config-telephony)# exit</pre>	<p>Returns to privileged EXEC mode.</p>
Step 8	<p>ephone-dn <i>dn-tag</i> [dual-line octo-line] or voice register dn <i>dn-tag</i></p> <p>Example:</p> <pre>Router(config)# ephone-dn 20 dual-line or Router(config)# voice register dn 20</pre>	<p>Enters directory number configuration mode.</p>
Step 9	<p>pickup-group <i>group-number</i></p> <p>Example:</p> <pre>Router(config-ephone-dn)# pickup-group 30 or Router(config-register-dn)# pickup-group 30</pre>	<p>Creates a pickup group and assigns the directory number to the group.</p> <ul style="list-style-type: none"> • <i>group-number</i>—String of up to 32 characters. Group numbers can vary in length but must have unique leading digits. For example, if there is a group number 17, there cannot also be a group number 177. • This command can also be configured in ephone-dn-template configuration mode and applied to one or more ephone-dns. The ephone-dn configuration has priority over the template configuration.
Step 10	<p>pickup-call any-group</p> <p>Example:</p> <pre>Router(config-ephone-dn)# pickup-call any-group or Router(config-register-dn)# pickup-call any-group</pre>	<p>Enables a phone user to pickup ringing calls on any extension belonging to a pickup group by pressing the GPickUp soft key and asterisk (*).</p> <ul style="list-style-type: none"> • The ringing extension must be configured with a pickup group using the pickup-group command. • If this command is not configured, the user can pickup calls in other groups by pressing the GPickUp soft key and dialing the pickup group number.

	Command or Action	Purpose
Step 11	end Example: Router(config-ephone-dn)# end or Router(config-register-dn)# end	Exits configuration mode.

Example

The following example shows the Group Pickup and Local Group Pickup features enabled with the **service directed-pickup gpickup** command. Extension 1005 on phone 5 and extension 1006 on phone 6 are assigned to pickup group 1.

```
telephony-service
load 7960-7940 P00308000500
load E61 SCCP61.8-2-2SR2S
max-ephones 100
max-dn 240
ip source-address 15.7.0.1 port 2000
service directed-pickup gpickup
cnf-file location flash:
cnf-file perphone
voicemail 8900
max-conferences 8 gain -6
call-park system application
transfer-system full-consult
fac standard
create cnf-files version-stamp 7960 Sep 25 2007 21:25:47
!
!
!
ephone-dn 5
number 1005
pickup-group 1
!
!
ephone-dn 6
number 1006
pickup-group 1
!
!
ephone 5
mac-address 0001.2345.6789
type 7962
button 1:5
!
!
!
ephone 6
mac-address 000F.F758.E70E
type 7962
button 1:6
```

Configure Call-Waiting Indicator Tone on SCCP Phone

To specify the type of audible call-waiting indicator on a SCCP phone, perform the following steps. The default is for directory numbers to accept call interruptions, such as call waiting, and to issue a beep tone. Instead of the standard call waiting beep, you can enable a ring tone for call-waiting.



Restriction

- The call-waiting ring option is not supported if the ephone-dn is configured with the **no call-waiting beep accept** command.
- If you configure a button to have a silent ring, you will not hear a call-waiting beep or call-waiting ring regardless of whether the ephone-dn associated with the button is configured to generate a call-waiting beep or call-waiting ring. To configure a button for silent ring, see [Assign Directory Numbers to SCCP Phones](#).
- The call-waiting beep volume cannot be adjusted through Cisco Unified CME for the Cisco Unified IP Phone 7902G, Cisco Unified IP Phone 7905G, Cisco Unified IP Phone 7912G, Cisco ATA-186, and Cisco ATA-188.
- The call-waiting ring option is not supported on the Cisco Unified IP Phone 7902G, Cisco Unified IP Phone 7905G, or Cisco Unified IP Phone 7912G.

SUMMARY STEPS

1. **enable**
2. **configure terminal**
3. **ephone-dn dn-tag [dual-line]**
4. **call-waiting beep [accept | generate]**
5. **call-waiting ring**
6. **end**

DETAILED STEPS

	Command or Action	Purpose
Step 1	enable Example: Router> enable	Enables privileged EXEC mode. <ul style="list-style-type: none">• Enter your password if prompted.
Step 2	configure terminal Example: Router# configure terminal	Enters global configuration mode.
Step 3	ephone-dn dn-tag [dual-line] Example: Router(config)# ephone-dn 20 dual-line	Enters ephone-dn configuration mode, creates an ephone-dn, and optionally assigns it dual-line status.
Step 4	call-waiting beep [accept generate] Example:	Enables an ephone-dn to generate or accept call-waiting beeps.

	Command or Action	Purpose
	Router(config-ephone-dn)# no call-waiting beep accept	<ul style="list-style-type: none"> • Default is directory number both accepts and generates call-waiting beep. • The beep is heard only if the other ephone-dn is configured to accept call-waiting beeps (default).
Step 5	call-waiting ring Example: Router(config-ephone-dn)# call-waiting ring	(Optional) Enables an ephone-dn to use a ring indicator for call-waiting notification. <ul style="list-style-type: none"> • To use this command, do not disable call-waiting beep by using the no call-waiting beep accept command.
Step 6	end Example: Router(config-ephone-dn)# end	Returns to privileged EXEC mode.

Verify Call-Waiting Indicator Tone on SCCP Phone

Step 1 Use the **show running-config** command to verify your configuration. Call-waiting settings are listed in the ephone-dn portion of the output. If the **no call-waiting beep generate** and the **no call-waiting beep accept** commands are configured, the **show running-config** command output will display the **no call-waiting beep** command.

Example:

```
Router# show running-config
!
ephone-dn 3 dual-line
 number 126
 name Accounting
 preference 2 secondary 9
 huntstop
 huntstop channel
 call-waiting beep
!
```

Step 2 Use the **show telephony-service ephone-dn** command to display call-waiting configuration information.

Example:

```
Router# show telephony-service ephone-dn

ephone-dn 1 dual-line
 number 126 secondary 1261
 preference 0 secondary 9
 no huntstop
```

```

huntstop channel
call-forward busy 500 secondary
call-forward noan 500 timeout 10
call-waiting beep

```

Configure Cancel Call Waiting on SCCP Phone

To enable a phone user to cancel call waiting by using the CWOFF soft key or a FAC, perform the following steps.



Restriction

- Call Waiting must be disabled by pressing the CWOFF soft key or using the FAC before placing a call; it cannot be activated or deactivated during a call.
- The CWOFF soft key is not available when initiating Call Transfer.

Before you begin

For information about standard and custom FACs, see [Feature Access Codes](#).

SUMMARY STEPS

1. **enable**
2. **configure terminal**
3. **ephone-template** *template-tag*
4. **softkeys seized** { [CallBack] [Cfwdall] [CWOFF] [Endcall] [Gpickup] [HLog] [MeetMe] [Pickup] [Redial] }
5. **exit**
6. **ephone** *phone-tag*
7. **ephone-template** *template-tag*
8. **exit**
9. **telephony-service**
10. **fac** {standard | custom *cew custom-fac*}
11. **end**

DETAILED STEPS

	Command or Action	Purpose
Step 1	enable Example: Router> enable	Enables privileged EXEC mode. <ul style="list-style-type: none"> • Enter your password if prompted.
Step 2	configure terminal Example:	Enters global configuration mode.

	Command or Action	Purpose
	Router# configure terminal	
Step 3	ephone-template <i>template-tag</i> Example: Router(config)# ephone-template 5	Enters ephone-template configuration mode to create an ephone template. <ul style="list-style-type: none"> • <i>template-tag</i>—Unique identifier for the ephone template. Range: 1 to 20.
Step 4	softkeys seized { [CallBack] [Cfdall] [CWOff] [Endcall] [Gpickup] [HLog] [MeetMe] [Pickup] [Redial] } Example: Router(config-ephone-template)# softkeys seized CWOff Cfdall Endcall Redial	(Optional) Modifies the order and type of soft keys that display on an IP phone during the seized call state. <ul style="list-style-type: none"> • You can enter any of the keywords in any order. • Default is all soft keys are displayed in alphabetical order. • Any soft key that is not explicitly defined is disabled.
Step 5	exit Example: Router(config-ephone-template)# exit	Exits ephone-template configuration mode.
Step 6	ephone <i>phone-tag</i> Example: Router(config)# ephone 12	Enters ephone configuration mode. <ul style="list-style-type: none"> • <i>phone-tag</i>—Unique number that identifies this ephone during configuration tasks.
Step 7	ephone-template <i>template-tag</i> Example: Router(config-ephone)# ephone-template 5	Applies the ephone template to the phone. <ul style="list-style-type: none"> • <i>template-tag</i>—Unique identifier of the ephone template that you created in Step 3, on page 51.
Step 8	exit Example: Router(config-ephone)# exit	Exits ephone configuration mode.
Step 9	telephony-service Example: Router(config)# telephony-service	Enters telephony-service configuration mode.
Step 10	fac { standard custom ccw <i>custom-fac</i> } Example: Router(config-telephony)# fac custom ccw **8	Enables standard FACs or creates a custom FAC or alias. <ul style="list-style-type: none"> • standard—Enables standard FACs for all phones. Standard FAC for cancel call waiting is *1. • custom—Creates a custom FAC for a FAC type. • <i>custom-fac</i>—User-defined code to be dialed using the keypad on an IP or analog phone. Custom FAC can be up to 256 characters long and contain numbers 0 to 9 and * and #.

	Command or Action	Purpose
Step 11	end Example: Router(config-telephony)# end	Returns to privileged EXEC mode.

Example

The following example shows a configuration where the order of the CWOFF soft key is modified for the seized call state in ephone template 5 and assigned to ephone 12. A custom FAC for cancel call waiting is set to **8.

```
telephony-service
max-ephones 100
max-dn 240
voicemail 8900
max-conferences 8 gain -6
transfer-system full-consult
fac custom cancel call waiting **8
!
!
ephone-template 5
softkeys seized CWOFF Cfwdall Endcall Redial
!
!
ephone 12
ephone-template 5
mac-address 000F.9054.31BD
type 7960
button 1:10 2:7
```

Enable Call Waiting on SIP Phones

To enable call waiting on an individual SIP phone, perform the following steps.

Before you begin

- Cisco Unified CME 3.4 or a later version.
- **mode cme** command must be configured in Cisco Unified CME.

SUMMARY STEPS

1. **enable**

2. **configure terminal**
3. **voice register pool** *pool-tag*
4. **call-waiting**
5. **exit**
6. **voice register global**
7. **hold-alert**
8. **end**

DETAILED STEPS

	Command or Action	Purpose
Step 1	enable Example: Router> enable	Enables privileged EXEC mode. <ul style="list-style-type: none"> • Enter your password if prompted.
Step 2	configure terminal Example: Router# configure terminal	Enters global configuration mode.
Step 3	voice register pool <i>pool-tag</i> Example: Router(config)# voice register pool 3	Enters voice register pool configuration mode to set phone-specific parameters for a SIP phone in Cisco Unified CME.
Step 4	call-waiting Example: Router(config-register-pool)# call-waiting	Configures call waiting on the SIP phone being configured. <p>Note This step is included to illustrate how to enable the command if it was previously disabled.</p> <ul style="list-style-type: none"> • Default: Enabled.
Step 5	exit Example: Router(config-register-pool)# exit	Exits voice register pool configuration mode.
Step 6	voice register global Example: Router(config)# voice register global	Enters voice register global configuration mode to set parameters for all supported SIP phones in Cisco Unified CME.
Step 7	hold-alert Example: Router(config-register-global)# hold-alert	Sets an audible alert notification when a call is on hold on a SIP phone. Default is disabled.
Step 8	end Example: Router(config-register-global)# end	Exits to privileged EXEC mode.

Configure Ephone-Hunt Groups on SCCP Phones

To define a hunt group and optional agent availability parameters, perform the following steps.



Restriction

- The HLog soft key is available only on display phones. It is not available on Cisco Unified IP Phones 7902, 7905, and 7912; Cisco IP Communicator; and Cisco VG224.
- Shared ephone-dns cannot use the Agent Status Control or Automatic Agent Not-Ready feature.
- If directory numbers that are members of a hunt group are configured for called-name display, the following restrictions apply:
 - The primary or secondary pilot number must be defined using at least one wildcard character.
 - The phone numbers in the **list** command cannot contain wildcard characters.
- If Call Forward All or Call Forward Busy is configured for a hunt group member (directory number), the hunt group ignores it.

Before you begin

Directory numbers included in a hunt group must be configured in Cisco Unified CME. For configuration information, see [Create Directory Numbers for SCCP Phones](#).

SUMMARY STEPS

1. **enable**
2. **configure terminal**
3. **ephone-hunt** *hunt-tag* {**longest-idle** | **peer** | **sequential**}
4. **pilot** *number* [**secondary** *number*]
5. **list** *number* [, *number...*]
6. **final** *final-number*
7. **hops** *number*
8. **timeout** *seconds* [, *seconds...*]
9. **max-timeout** *seconds*
10. **preference** *preference-order* [**secondary** *secondary-order*]
11. **no-reg** [**both** | **pilot**]
12. **fwd-final** {**orig-phone** | **final**}
13. **forward local-calls**
14. **secondary start** [**current** | **next** | *list-position*]
15. **present-call** {**idle-phone** | **onhook-phone**}
16. **from-ring**
17. **description** *text-string*
18. **display-logout** *text-string*
19. **exit**
20. **telephony-service**
21. **max-redirect** *number*

22. **hunt-group logout** {DND | HLog}
23. **exit**
24. **ephone-dn dn-tag**
25. **ephone-hunt login**
26. **end**

DETAILED STEPS

	Command or Action	Purpose
Step 1	enable Example: <pre>Router> enable</pre>	Enables privileged EXEC mode. <ul style="list-style-type: none"> • Enter your password if prompted.
Step 2	configure terminal Example: <pre>Router# configure terminal</pre>	Enters global configuration mode.
Step 3	ephone-hunt hunt-tag {longest-idle peer sequential} Example: <pre>Router(config)# ephone-hunt 23 peer</pre>	Enters ephone-hunt configuration mode to define an ephone hunt group. <ul style="list-style-type: none"> • hunt-tag—Unique sequence number that identifies this hunt group during configuration tasks. Range: 1 to 100. Cisco CME 3.3 and earlier—Range: 1 to 10 • longest-idle—Calls go to the ephone-dn that has been idle the longest for the number of hops specified when the ephone hunt group was defined. The longest-idle is determined from the last time that a phone registered, reregistered, or went on-hook. • peer—First ephone-dn to ring is the number to the right of the ephone-dn that was the last to ring when the pilot number was last called. Ringing proceeds in a circular manner, left to right, for the number of hops specified when the ephone hunt group was defined. • sequential—Ephone-dns ring in the left-to-right order in which they are listed when the hunt group is defined.
Step 4	pilot number [secondary number] Example: <pre>Router(config-ephone-hunt)# pilot 5601</pre>	Defines the pilot number, which is the number that callers dial to reach the hunt group. <ul style="list-style-type: none"> • number—E.164 number up to 27 characters. The dialplan pattern can be applied to the pilot number. • secondary—(Optional) Defines an additional pilot number for the ephone hunt group.

	Command or Action	Purpose
Step 5	<p>list <i>number</i> [, <i>number</i>...]</p> <p>Example:</p> <pre>Router(config-ephone-hunt)# list 5001, 5002, 5017, 5028</pre>	<p>Defines the list of numbers (from 2 and 20) to which the ephone hunt group redirects the incoming calls.</p> <ul style="list-style-type: none"> <i>number</i>—E.164 number up to 27 characters. Primary or secondary number assigned to an ephone-dn.
Step 6	<p>final <i>final-number</i></p> <p>Example:</p> <pre>Router(config-ephone-hunt)# final 6000</pre>	<p>Defines the last number in the ephone hunt group, after which the call is no longer redirected. Can be an ephone-dn primary or secondary number, a voice-mail pilot number, a pilot number of another hunt group, or an FXS number.</p> <p>Note When a final number is defined as a pilot number of another hunt group, the pilot number of the first hunt group cannot be configured as a final number in any other hunt group.</p> <p>Note This command is not used for ephone hunt groups that are part of a Cisco Unified CME B-ACD service. The final destination for those groups is determined by the B-ACD service.</p>
Step 7	<p>hops <i>number</i></p> <p>Example:</p> <pre>Router(config-ephone-hunt)# hops 7</pre>	<p>(Optional; peer and longest-idle hunt groups only) Sets the number of hops before a call proceeds to the final number.</p> <ul style="list-style-type: none"> <i>number</i>—Number of hops before the call proceeds to the final ephone-dn. Range is 2 to 20, but the value must be less than or equal to the number of extensions that are specified in the list command. Default automatically adjusts to the number of hunt group members.
Step 8	<p>timeout <i>seconds</i> [, <i>seconds</i>...]</p> <p>Example:</p> <pre>Router(config-ephone-hunt)# timeout 7, 10, 15</pre>	<p>(Optional) Sets the number of seconds after which an unanswered call is redirected to the next number in the hunt-group list.</p> <ul style="list-style-type: none"> <i>seconds</i>—Number of seconds. Range: 3 to 60000. Multiple entries can be made, separated by commas, that must correspond to the number of ephone-dns in the list command. Each number in a multiple entry specifies the time that the corresponding ephone-dn will ring before a call is forwarded to the next number in the list. If a single number is entered, it is used for the no-answer period for each ephone-dn. If this command is not used, the default is the number of seconds set by the timeouts ringing command, which defaults to 180 seconds. Note that the default of 180 seconds may be greater than you desire.

	Command or Action	Purpose
Step 9	<p>max-timeout <i>seconds</i></p> <p>Example:</p> <pre>Router(config-ephone-hunt)# max-timeout 25</pre>	<p>(Optional) Sets the maximum combined timeout for the no-answer periods for all ephone-dns in the ephone-hunt list. The call proceeds to the final destination when this timeout expires, regardless of whether it has completed the hunt cycle.</p> <ul style="list-style-type: none"> • <i>seconds</i>—Number of seconds. Range is 3 to 60000. • If this command is not used, the default is that no combined timeout limit is set.
Step 10	<p>preference <i>preference-order</i> [secondary <i>secondary-order</i>]</p> <p>Example:</p> <pre>Router(config-ephone-hunt)# preference 1</pre>	<p>(Optional) Sets a preference order for the ephone-dn associated with the hunt-group pilot number.</p> <ul style="list-style-type: none"> • <i>preference-order</i>—See the CLI help for a range of numeric values, where 0 is the highest preference. Default is 0. • secondary <i>secondary-order</i>—(Optional) Preference order for the secondary pilot number. See the CLI help for a range of numeric values, where 0 is the highest preference. Default is 7.
Step 11	<p>no-reg [both pilot]</p> <p>Example:</p> <pre>Router(config-ephone-hunt)# no-reg</pre>	<p>(Optional) Prevents the hunt-group pilot number from registering with an H.323 gatekeeper. If this command is not used, the default is that the pilot number registers with the H.323 gatekeeper.</p> <ul style="list-style-type: none"> • both—(Optional) Both the primary and secondary pilot numbers are not registered. • pilot—(Optional) Only the primary pilot number is not registered. • In Cisco CME 3.1 and later versions, if this command is used without either the both or pilot keywords, only the secondary number is not registered.
Step 12	<p>fwd-final {orig-phone final}</p> <p>Example:</p> <pre>Router(config-ephone-hunt)# fwd-final orig-phone</pre>	<p>(Optional) For calls that have been transferred into an ephone hunt group by a local extension, determines the final destination of a call that is not answered in the hunt group.</p> <ul style="list-style-type: none"> • final—Forwards the call to the ephone-dn number that is specified in the final command. • orig-phone—Forwards the call to the primary directory number of the phone that transferred the call into the hunt group.
Step 13	<p>forward local-calls</p> <p>Example:</p>	<p>(Optional; sequential hunt groups only) Specifies that local calls (calls from ephone-dns on the same</p>

	Command or Action	Purpose
	<code>Router(config-ephone-hunt)# no forward local-calls</code>	Cisco Unified CME system) will not be forwarded past the first list member in a hunt group. If the first member is busy, the internal caller hears busy. If the first number does not answer, the internal caller hears ringback.
Step 14	<p>secondary start [current next <i>list-position</i>]</p> <p>Example:</p> <pre>Router(config-ephone-hunt)# secondary start next</pre>	<p>(Optional) For calls that are parked by hunt group member phones, returns them to a different entry point in the hunt group (as specified in this command) if the calls are recalled from park to the secondary pilot number or transferred from park to an ephone-dn that forwards the call to the secondary pilot number.</p> <ul style="list-style-type: none"> • current—The ephone-dn that parked the call. • next—The ephone-dn in the hunt group list that follows the ephone-dn that parked the call. • <i>list-position</i>—The ephone-dn at the specified position in the list specified by the list command. Range is 1 to 10.
Step 15	<p>present-call {idle-phone onhook-phone}</p> <p>Example:</p> <pre>Router(config-ephone-hunt)# present-call idle-phone</pre>	<p>(Optional) Presents ephone-hunt-group calls only to member phones that are idle or onhook, as specified.</p> <ul style="list-style-type: none"> • idle-phone—A call from the ephone-hunt group is presented to an ephone only if all lines on the phone are idle. This option ignores monitored lines that have been configured on the phone using the button m command. • onhook-phone—A call from the ephone-hunt group is presented to an ephone only if the phone is in the on-hook state. When this keyword is configured, calls in the ringing or hold state that are unrelated to the hunt group do not prevent the presentation of calls from the ephone-hunt group.
Step 16	<p>from-ring</p> <p>Example:</p> <pre>Router(config-ephone-hunt)# from-ring</pre>	<p>(Optional) Specifies that on-hook time stamps should be recorded when calls ring extensions and when calls are answered. The default is that on-hook time stamps are recorded only when calls are answered.</p>
Step 17	<p>description <i>text-string</i></p> <p>Example:</p> <pre>Router(config-ephone-hunt)# description Marketing Hunt Group</pre>	<p>(Optional) Defines text that will appear in configuration output.</p>
Step 18	<p>display-logout <i>text-string</i></p> <p>Example:</p> <pre>Router(config-ephone-hunt)# display-logout Night Service</pre>	<p>(Optional) Defines text that will appear on IP phones that are members of a hunt group when all the hunt-group members are in the not-ready status. This string can be</p>

	Command or Action	Purpose
		used to inform hunt-group members where the calls are being sent when all members are unavailable to take calls.
Step 19	exit Example: <pre>Router(config-ephone-hunt)# exit</pre>	Exits ephone-hunt configuration mode.
Step 20	telephony-service Example: <pre>Router(config)# telephony-service</pre>	Enters telephony-service configuration mode.
Step 21	max-redirect number Example: <pre>Router(config-telephony)# max-redirect 8</pre>	(Optional) Sets the number of times that a call can be redirected within a Cisco Unified CME system. <ul style="list-style-type: none"> • <i>number</i>—Range is 5 to 20. Default is 10. Note This command is required if the number of hops is greater than 10.
Step 22	hunt-group logout {DND HLog} Example: <pre>Router(config-telephony)# hunt-group logout HLog</pre>	(Optional) Specifies whether agent not-ready status applies only to ephone hunt group extensions on a phone (HLog mode) or to all extensions on a phone (DND mode). Agent not-ready status can be activated by an agent using the HLog softkey or a FAC, or it can be activated automatically after the number of calls specified in the auto logout command are not answered. <p>The default of this command is not used is DND.</p> <ul style="list-style-type: none"> • DND—When phones are placed in agent not-ready status, all ephone-dns on the phone will not accept calls. • HLog—Enables the display of the HLog soft key. When phones are placed in the agent not-ready status, only the ephone-dns assigned to ephone hunt groups will not accept calls.
Step 23	exit Example: <pre>Router(config-telephony)# exit</pre>	Exits telephony-service configuration mode.
Step 24	ephone-dn dn-tag Example: <pre>Router(config)# ephone-dn 29</pre>	(Optional) Enters ephone-dn configuration mode. <ul style="list-style-type: none"> • <i>dn-tag</i>—Tag number for the ephone-dn to be authorized to join and leave ephone hunt groups.
Step 25	ephone-hunt login Example: <pre>Router(config-ephone-dn)# ephone-hunt login</pre>	(Optional) Enables this ephone-dn to join and leave ephone hunt groups (dynamic membership).

	Command or Action	Purpose
Step 26	end Example: Router(config-ephone-dn)# end	Returns to privileged EXEC mode.

Verify Ephone Hunt Groups Configuration

Step 1 Use the **show running-config** command to verify your configuration. Ephone hunt group parameters are listed in the ephone-hunt portion of the output.

Example:

```
Router# show running-config
ephone-hunt 1 longest-idle
pilot 500
list 502, 503, *
max-timeout 30
timeout 10, 10, 10
hops 2
from-ring
fwd-final orig-phone
!
!
ephone-hunt 2 sequential
pilot 600
list 621, *, 623
final 5255348
max-timeout 10
timeout 20, 20, 20
fwd-final orig-phone
!
!
ephone-hunt 77 longest-idle
from-ring
pilot 100
```

```
list 101, *, 102
!
```

Step 2

To verify the configuration of ephone hunt group dynamic membership, use the **show running-config** command. Look at the ephone-hunt portion of the output to ensure at least one wildcard slot is configured. Look at the ephone-dn section to see whether particular ephone-dns are authorized to join ephone hunt groups. Look at the telephony-service section to see whether FACs are enabled.

Example:

```
Router# show running-config
ephone-hunt 1 longest-idle
pilot 500
list 502, 503, *
max-timeout 30
timeout 10, 10, 10
hops 2
from-ring
fwd-final orig-phone
!
!
ephone-dn 2 dual-line
number 126
preference 1
call-forward busy 500
ephone-hunt login
!
telephony-service
fac custom alias 5 *5 to *35000
fac custom ephone-hunt cancel #5
```

Step 3

Use the **show ephone-hunt** command for detailed information about hunt groups, including dial-peer tag numbers, hunt-group agent status, and on-hook time stamps. This command also displays the dial-peer tag numbers of all ephone-dns that have joined dynamically and are members of the group at the time that the command is run.

Example:

```
Router# show ephone-hunt

Group 1
type: peer
pilot number: 450, peer-tag 20123
list of numbers:
```

```

451, aux-number A450A0900, # peers 5, logout 0, down 1
peer-tag dn-tag rna login/logout up/down
[20122 42 0 login up ]
[20121 41 0 login up ]
[20120 40 0 login up ]
[20119 30 0 login up ]
[20118 29 0 login down]
452, aux-number A450A0901, # peers 4, logout 0, down 0
peer-tag dn-tag rna login/logout up/down
[20127 45 0 login up ]
[20126 44 0 login up ]
[20125 43 0 login up ]
[20124 31 0 login up ]
453, aux-number A450A0902, # peers 4, logout 0, down 0
peer-tag dn-tag rna login/logout up/down
[20131 48 0 login up ]
[20130 47 0 login up ]
[20129 46 0 login up ]
[20128 32 0 login up ]
477, aux-number A450A0903, # peers 1, logout 0, down 0
peer-tag dn-tag rna login/logout up/down
[20132 499 0 login up ]
preference: 0
preference (sec): 7
timeout: 3, 3, 3, 3
max timeout : 10
hops: 4
next-to-pick: 1
E.164 register: yes
auto logout: no
stat collect: no
Group 2
type: sequential
pilot number: 601, peer-tag 20098
list of numbers:
123, aux-number A601A0200, # peers 1, logout 0, down 0
peer-tag dn-tag rna login/logout up/down
[20097 56 0 login up ]
622, aux-number A601A0201, # peers 3, logout 0, down 0
peer-tag dn-tag rna login/logout up/down
[20101 112 0 login up ]
[20100 111 0 login up ]
[20099 110 0 login up ]
623, aux-number A601A0202, # peers 3, logout 0, down 0
peer-tag dn-tag rna login/logout up/down
[20104 122 0 login up ]
[20103 121 0 login up ]
[20102 120 0 login up ]
*, aux-number A601A0203, # peers 1, logout 0, down 1
peer-tag dn-tag rna login/logout up/down
[20105 0 0 - down]
*, aux-number A601A0204, # peers 1, logout 0, down 1
peer-tag dn-tag rna login/logout up/down
[20106 0 0 - down]
final number: 5255348
preference: 0
preference (sec): 9
timeout: 5, 5, 5, 5, 5
max timeout : 40
fwd-final: orig-phone
E.164 register: yes
auto logout: no
stat collect: no
Group 3

```

```
type: longest-idle
pilot number: 100, peer-tag 20142
list of numbers:
101, aux-number A100A9700, # peers 3, logout 0, down 3
on-hook time stamp 7616, off-hook agents=0
peer-tag dn-tag rna login/logout up/down
[20141 132 0 login down]
[20140 131 0 login down]
[20139 130 0 login down]
*, aux-number A100A9701, # peers 1, logout 0, down 1
on-hook time stamp 7616, off-hook agents=0
peer-tag dn-tag rna login/logout up/down
[20143 0 0 - down]
102, aux-number A100A9702, # peers 2, logout 0, down 2
on-hook time stamp 7616, off-hook agents=0
peer-tag dn-tag rna login/logout up/down
[20145 142 0 login down]
[20144 141 0 login down]
all agents down!
preference: 0
preference (sec): 7
timeout: 100, 100, 100
hops: 0
E.164 register: yes
auto logout: no
stat collect: no
```

Configure Voice-Hunt Groups

To redirect calls for a specific number (pilot number) to a defined group of directory numbers on Cisco Unified SCCP and SIP IP phones, perform the following steps.

**Restriction**

- Before Cisco Unified CME 4.3, forwarding or transferring to a voice hunt group is not supported.
- In Cisco Unified CME 4.3 and later versions, Call Forwarding is supported to a parallel hunt-group (blast hunt group) only.
- SIP-to-H.323 calls are not supported.
- If Call Forward All or Call Forward Busy is configured for a hunt group member (directory number), the hunt group ignores it.
- Caller ID update is not supported for supplementary services.
- Voice hunt groups are subject to the max-redirect restriction.
- A pilot dial peer cannot be used for a voice hunt group and an ephone hunt group at the same time.
- Voice hunt groups do not support the expansion of pilot numbers using the **dialplan-pattern** command. To enable external phones to dial the pilot number, you must configure a secondary pilot number using a fully qualified E.164 number.
- If call-waiting is enabled (the default), parallel hunt groups support multiple calls up to the limit of call-waiting calls supported by the particular SIP phone model. If call waiting is disabled, parallel hunt groups support only one call at a time in the ringing state. Phones that fail to connect must return to the on-hook state before they can receive other calls.
- A phone number associated with an FXO port is not supported in parallel hunt groups.
- If the directory number (member of a voice hunt group) is a shared line, agent status control or HLog is not supported.
- From Unified CME release 11.6 onwards, line level logout or login is not supported for SIP phones.
- DND FAC is not supported with SIP phones on Unified CME.
- Consider an SCCP DN that is part of both voice hunt group and ephone hunt group. If voice hunt group is configured with members logout or auto logout, then the SCCP DN will logout only from voice hunt group. If ephone hunt group is configured with members logout or auto logout, then the SCCP DN will logout from both voice hunt group and ephone hunt group.
- For Unified CME 12.1 and prior releases, mixed shared lines and SIP shared lines are not supported with voice hunt groups.
- For parallel voice hunt group, the maximum number of call blasts that can be supported is limited to 32. This includes the shared-line as well as normal directory numbers.
- Unified CME supports chaining (nesting) of a voice hunt group with another voice hunt group. The chaining of voice hunt groups is established by configuring the final number of the first voice hunt group as the pilot number of the second voice hunt group.
- Unified CME supports the chaining (nesting) of a maximum of two voice hunt groups. The configuration ensures that there is no looping of calls placed to a voice hunt group.

Before you begin

- Cisco Unified CME 3.4 or a later version for SIP phones.

- Cisco Unified CME 4.3 or a later version is required to include a SCCP phone, FXS analog phone, DS0-group, PRI-group, or SIP trunk in a voice hunt-group.
- Cisco Unified CME 4.3 or a later version is required for call transfer to a voice hunt-group.
- Directory numbers included in a hunt group must be configured in Cisco Unified CME. For configuration information, see [Configure Phones to Make Basic Call](#).
- Cisco Unified CME 11.6 or later is required to support HLog softkey, feature button, and agent status control.
- Cisco Unified CME 11.6 or later is required to configure **present-call**, **auto logout**, and **members logout** under voice hunt group configuration mode.
- Unified CME 12.2 or later is required to configure mixed shared lines and SIP shared lines with voice hunt groups.

SUMMARY STEPS

1. **enable**
2. **configure terminal**
3. **voicehunt-group** *hunt-tag* [**longest-idle** | **parallel** | **peer** | **sequential**]
4. **pilot number** [**secondary number**]
5. **list number**
6. **final number**
7. **preference** *preference-order* [**secondary** *secondary-order*]
8. **hops number**
9. **timeout** *seconds*
10. **present-call idle-phone**
11. **members logout**
12. **auto logout** *number-of-calls*
13. **exit**
14. **telephony-service**
15. **hunt-group logout** { **DND HLog** }
16. **exit**
17. **voice register dn** *tag*
18. **voice-hunt-groups login**
19. **end**

DETAILED STEPS

	Command or Action	Purpose
Step 1	enable Example: Router> enable	Enables privileged EXEC mode. <ul style="list-style-type: none"> • Enter your password if prompted.
Step 2	configure terminal Example:	Enters global configuration mode.

	Command or Action	Purpose
	Router# configure terminal	
Step 3	<p>voicehunt-group <i>hunt-tag</i> [longest-idle parallel peer sequential]</p> <p>Example: Router(config)# voice hunt-group 1 longest-idle</p>	<p>Enters voice hunt-group configuration mode to define a hunt group.</p> <ul style="list-style-type: none"> • <i>hunt-tag</i>—Unique sequence number of the hunt group to be configured. Range is 1 to 100. • longest idle—Hunt group in which calls go to the directory number that has been idle for the longest time. • sequential—Hunt group in which directory numbers ring in the order in which they are listed, left to right. • parallel—Hunt group in which all directory numbers ring simultaneously. • peer—Hunt group in which the call placed to a directory number rings for the next directory number in line. • To change the hunt-group type, remove the existing hunt group first by using the no form of the command; then, recreate the group.
Step 4	<p>pilot number [secondary number]</p> <p>Example: Router(config-voice-hunt-group)# pilot number 8100</p>	<p>Defines the telephone number that callers dial to reach a voice hunt group.</p> <ul style="list-style-type: none"> • <i>number</i>—String of up to 16 characters that represents an E.164 telephone number. • Number string may contain alphabetic characters when the number is to be dialed only by the Cisco Unified CME router, as with an intercom number, and not from telephone keypads. • secondary number—(Optional) Keyword and argument combination defines the number that follows as an additional pilot number for the voice hunt group. • Secondary numbers can contain wild cards. A wildcard is a period (.), which matches any entered digit.
Step 5	<p>list number</p> <p>Example: Router(config-voice-hunt-group)# list 8000, 8010, 8020, 8030</p>	<p>Creates a list of extensions that are members of a voice hunt group. To remove a list from a router configuration, use the no form of this command.</p> <ul style="list-style-type: none"> • <i>number</i>—List of extensions to be added as members to the voice hunt group. Separate the extensions with commas.

	Command or Action	Purpose
		<ul style="list-style-type: none"> • Add or delete all extensions in a hunt-group list at one time. You cannot add or delete a single number in an existing list. • There must be from 2 to 10 extensions in the hunt-group list, and each number must be a primary or secondary number. • Any number in the list cannot be a pilot number of a parallel hunt group.
Step 6	<p>final number</p> <p>Example:</p> <pre>Router(config-voice-hunt-group)# final 8888</pre>	<p>Defines the last extension in a voice hunt group.</p> <ul style="list-style-type: none"> • If a final number in one hunt group is configured as a pilot number of another hunt group, the pilot number of the first hunt group cannot be configured as a final number in any other hunt group. • This command is not used for voice hunt groups that are part of a Cisco Unified CME B-ACD service. The final destination for those groups is determined by the B-ACD service.
Step 7	<p>preference preference-order [secondary secondary-order]</p> <p>Example:</p> <pre>Router(config-voice-hunt-group)# preference 6</pre>	<p>Sets the preference order for the directory number associated with a voice hunt-group pilot number.</p> <p>Note We recommend that the parallel hunt-group pilot number be unique in the system. Parallel hunt groups may not work if there are more than one partial or exact dial-peer match. For example, if the pilot number is “8000” and there is another dial peer that matches “8...”. If multiple matches cannot be avoided, give parallel hunt groups the highest priority to run by assigning a lower preference to the other dial peers. Note that 8 is the lowest preference value. By default, dial peers created by parallel hunt groups have a preference of 0.</p> <ul style="list-style-type: none"> • <i>preference-order</i>—Range is 0 to 8, where 0 is the highest preference and 8 is the lowest preference. Default is 0. • secondary secondary-order—(Optional) Keyword and argument combination is used to set the preference order for the secondary pilot number. Range is 1 to 8, where 0 is the highest preference and 8 is the lowest preference. Default is 7.

	Command or Action	Purpose
Step 8	hops <i>number</i> Example: Router(config-voice-hunt-group)# hops 2	For configuring a peer or longest-idle voice hunt group only. Defines the number of times that a call can hop to the next number in a peer or longest-idle voice hunt group before the call proceeds to the final number. <ul style="list-style-type: none"> • <i>number</i>—Number of hops. Range is 2 to 10, and the value must be less than or equal to the number of extensions specified by the list command. • Default is the same number as there are destinations defined under the list command.
Step 9	timeout <i>seconds</i> Example: Router(config-voice-hunt-group)# timeout 100	Defines the number of seconds after which a call that is not answered is redirected to the next directory number in a voice hunt-group list. <ul style="list-style-type: none"> • Default: 180 seconds.
Step 10	present-call <i>idle-phone</i> Example: Router(config-voice-hunt-group)# present-call idle-phone	Specifies that voice hunt-group calls are presented only if all lines are idle on the phone on which the hunt-group line appears.
Step 11	members <i>logout</i> Example: Router(config-voice-hunt-group)# members logout	Configures a Cisco Unified CME system for all non-shared static members or agents in a voice hunt group with the Hlogout initial state.
Step 12	auto <i>logout number-of-calls</i> Example: Router(config-voice-hunt-group)# auto logout 2	Enables the automatic change of a voice hunt group agent's voice register dn or ephone-dn to not-ready status after a specified number of successive hunt-group calls are not answered.
Step 13	exit Example: Router(config-voice-hunt-group)# exit	Exits voice-hunt-group configuration mode.
Step 14	telephony-service Example: Router(config)# telephony-service	Enters telephony-service configuration mode.
Step 15	hunt-group <i>logout {DND HLog }</i> Example: Router(config-telephony)# hunt-group logout Hlog	(Optional) Specifies HLog softkey functions. Agent not-ready status can be activated by an agent using the HLog softkey or a FAC.
Step 16	exit Example: Router(config-telephony)# exit	Exits telephony-service configuration mode.

	Command or Action	Purpose
Step 17	voice register dn tag Example: Router(config)# voice register dn 29	(Optional) Enters voice register dn configuration mode. <ul style="list-style-type: none"> • <i>tag</i>—Tag number for voice register dn to be authorized to join and leave voice hunt groups.
Step 18	voice-hunt-groups login Example: Router(config-register-dn)# voice-hunt-groups login	(Optional) Enables this voice register dn to join and leave voice hunt groups (dynamic membership).
Step 19	end Example: Router(config-register-dn)# end	Exits to privileged EXEC mode.

Verify Voice Hunt Groups Configuration

Step 1 Use the **show running-config** command to verify your configuration. Voice hunt group parameters are listed in the voice-hunt portion of the output.

Example:

```
Router# show running-config
```

```
voice-hunt 1 longest-idle
pilot 500
list 502, 503, *
max-timeout 30
timeout 10, 10, 10
hops 2
from-ring
fwd-final orig-phone
!
!
voice-hunt 2 sequential
pilot 600
list 621, *, 623
final 5255348
max-timeout 10
timeout 20, 20, 20
fwd-final orig-phone
!
!
voice-hunt 77 longest-idle
from-ring
pilot 100
list 101, *, 102
!
```

Step 2 To verify the configuration of voice hunt group dynamic membership, use the **show running-config** command. Look at the voice-hunt portion of the output to ensure at least one wildcard slot is configured. Look at the voice-dn section to see whether particular ephone-dns are authorized to join voice hunt groups. Look at the telephony-service section to see whether FACs are enabled.

Example:

```
Router# show running-config
```

```
voice-hunt 1 longest-idle
pilot 500
list 502, 503, *
max-timeout 30
timeout 10, 10, 10
hops 2
from-ring
fwd-final orig-phone
!
!
voice-dn 2 dual-line
number 126
preference 1
call-forward busy 500
ephone-hunt login
!
telephony-service
fac custom alias 5 *5 to *35000
fac custom ephone-hunt cancel #5
```

Step 3

Use the **show ephone-hunt** command for detailed information about hunt groups, including dial-peer tag numbers, hunt-group agent status, and on-hook time stamps. This command also displays the dial-peer tag numbers of all ephone-dns that have joined dynamically and are members of the group at the time that the command is run.

Example:

```
Router# show ephone-hunt
```

```
Group 1
type: peer
pilot number: 450, peer-tag 20123
list of numbers:
451, aux-number A450A0900, # peers 5, logout 0, down 1
peer-tag dn-tag rna login/logout up/down
[20122 42 0 login up ]
[20121 41 0 login up ]
[20120 40 0 login up ]
[20119 30 0 login up ]
[20118 29 0 login down]
452, aux-number A450A0901, # peers 4, logout 0, down 0
peer-tag dn-tag rna login/logout up/down
[20127 45 0 login up ]
[20126 44 0 login up ]
[20125 43 0 login up ]
[20124 31 0 login up ]
453, aux-number A450A0902, # peers 4, logout 0, down 0
peer-tag dn-tag rna login/logout up/down
[20131 48 0 login up ]
[20130 47 0 login up ]
[20129 46 0 login up ]
[20128 32 0 login up ]
477, aux-number A450A0903, # peers 1, logout 0, down 0
peer-tag dn-tag rna login/logout up/down
[20132 499 0 login up ]
preference: 0
preference (sec): 7
timeout: 3, 3, 3, 3
max timeout : 10
hops: 4
next-to-pick: 1
```

```
E.164 register: yes
auto logout: no
stat collect: no
Group 2
type: sequential
pilot number: 601, peer-tag 20098
list of numbers:
123, aux-number A601A0200, # peers 1, logout 0, down 0
peer-tag dn-tag rna login/logout up/down
[20097 56 0 login up ]
622, aux-number A601A0201, # peers 3, logout 0, down 0
peer-tag dn-tag rna login/logout up/down
[20101 112 0 login up ]
[20100 111 0 login up ]
[20099 110 0 login up ]
623, aux-number A601A0202, # peers 3, logout 0, down 0
peer-tag dn-tag rna login/logout up/down
[20104 122 0 login up ]
[20103 121 0 login up ]
[20102 120 0 login up ]
*, aux-number A601A0203, # peers 1, logout 0, down 1
peer-tag dn-tag rna login/logout up/down
[20105 0 0 - down]
*, aux-number A601A0204, # peers 1, logout 0, down 1
peer-tag dn-tag rna login/logout up/down
[20106 0 0 - down]
final number: 5255348
preference: 0
preference (sec): 9
timeout: 5, 5, 5, 5, 5
max timeout : 40
fwd-final: orig-phone
E.164 register: yes
auto logout: no
stat collect: no
Group 3
type: longest-idle
pilot number: 100, peer-tag 20142
list of numbers:
101, aux-number A100A9700, # peers 3, logout 0, down 3
on-hook time stamp 7616, off-hook agents=0
peer-tag dn-tag rna login/logout up/down
[20141 132 0 login down]
[20140 131 0 login down]
[20139 130 0 login down]
*, aux-number A100A9701, # peers 1, logout 0, down 1
on-hook time stamp 7616, off-hook agents=0
peer-tag dn-tag rna login/logout up/down
[20143 0 0 - down]
102, aux-number A100A9702, # peers 2, logout 0, down 2
on-hook time stamp 7616, off-hook agents=0
peer-tag dn-tag rna login/logout up/down
[20145 142 0 login down]
[20144 141 0 login down]
all agents down!
preference: 0
preference (sec): 7
timeout: 100, 100, 100
hops: 0
E.164 register: yes
auto logout: no
stat collect: no
```

Enable Audible Tone for Successful Login and Logout of a Hunt Group on SCCP Phone

The user can enable playing of audible tone on an SCCP phone to confirm a successful join or unjoin and login or logout from a hunt group (applies to both ephone and voice hunt group). From Cisco Unified CME 10.5 onwards, distinct audible tone will be played for the following scenarios:

1. To join and unjoin a hunt group via FAC
2. To log in and log out from hunt group via Hlog/DND, or FAC

The audible tone will be played for ephone hunt group and voice hunt group for SCCP Phones.



Restriction • Supports all 79xx phones except for 7926 wireless phones.

Before you begin

- Cisco Unified CME 10.5 or a later version
- Ephone or voice hunt group should be configured
- Ephone should be static or dynamic member of hunt group.

SUMMARY STEPS

1. **enable**
2. **configure terminal**
3. **ephone** *phone-tag* or **ephone-template** *template-tag*
4. **audible tone**
5. **end**

DETAILED STEPS

	Command or Action	Purpose
Step 1	enable Example: Router> enable	Enables privileged EXEC mode. • Enter your password if prompted.
Step 2	configure terminal Example: Router# configure terminal	Enters global configuration mode.
Step 3	ephone <i>phone-tag</i> or ephone-template <i>template-tag</i> Example: Router(config)# ephone 25	Enters ephone configuration mode. • <i>phone-tag</i> —The unique sequence number of the phone that will be notified when an incoming call is received by a night-service ephone-dn during a night-service period. or

	Command or Action	Purpose
		Enters ephone-template configuration mode to create an ephone template. <ul style="list-style-type: none"> <i>template-tag</i>—Unique identifier for the ephone template that is being created. Range: 1 to 20.
Step 4	audible tone Example: Router(config-ephone)# audible tone	Enables playing of audible tone on an SCCP phone to confirm a successful login or logout.
Step 5	end Example: Router(config-ephone)# end	

Example

The following example shows that audible tone is configured in voice register pool configuration mode:

```
!
Router(config)# ephone 1
Router(config-ephone)# device-security-mode none
Router(config-ephone)# mac-address 64D8.14A5.C87A
Router(config-ephone)# type 7965
Router(config-ephone)# button 1:3
Router(config-ephone)# audible-tone!
```

Enable the Collection of Call Statistics for Voice Hunt-Groups

To enable the collection of call statistics for voice hunt groups, perform the following steps.



Restriction Hold and resume statistics are not updated for remote SCCP voice hunt group agents.

Before you begin

Cisco Unified CME 9.0 or a later version.

SUMMARY STEPS

1. enable
2. configure terminal
3. voice hunt-group *hunt-tag* {longest-idle | parallel | peer | sequential}
4. statistics collect
5. end

DETAILED STEPS

	Command or Action	Purpose
Step 1	enable Example: Router> enable	Enables privileged EXEC mode. <ul style="list-style-type: none"> • Enter your password if prompted.
Step 2	configure terminal Example: Router# configure terminal	Enters global configuration mode.
Step 3	voice hunt-group <i>hunt-tag</i> { longest-idle parallel peer sequential } Example: Router(config)# voice hunt-group 60 longest-idle	Enters voice hunt-group configuration mode. <ul style="list-style-type: none"> • <i>hunt-tag</i>—Unique sequence number that identifies the hunt group. Range: 1 to 100. • longest-idle—Hunt group in which calls go to the directory number that has been idle the longest. • parallel—Hunt group in which calls simultaneously ring multiple phones. • peer—Hunt group in which the first extension to ring is selected round-robin from the list. Ringing proceeds in a circular manner, left to right, for the number of hops specified when the hunt group is defined. The round-robin selection starts with the number left of the number that answered when the hunt-group was last called. • sequential—Hunt group in which extensions ring in the order in which they are listed, left to right, when the hunt group was defined.
Step 4	statistics collect Example: Router(config-voice-hunt-group)# statistics collect	Enables the collection of call statistics for a voice hunt group.
Step 5	end Example: Router(config-voice-hunt-group)# end	Exits to privileged EXEC mode.

Associate a Name with a Called Voice Hunt-Group

**Restriction**

Cisco Unified SIP IP phones are not supported. The display support applies to Cisco Unified SCCP IP phones on voice hunt-group and ephone-hunt configuration modes only.

Before you begin

Cisco Unified CME 9.5 or a later version.

SUMMARY STEPS

1. **enable**
2. **configure terminal**
3. **voice hunt-group** *hunt-tag* {**parallel**}
4. **final** *number*
5. **list** *number* [, *number...*]
6. **timeout** *seconds*
7. **pilot** *number* [**secondary** *number*]
8. **name** “*primary pilot name*” [**secondary** “*secondary pilot name*”]

DETAILED STEPS

	Command or Action	Purpose
Step 1	enable Example: Router> enable	Enables privileged EXEC mode. <ul style="list-style-type: none">• Enter your password if prompted.
Step 2	configure terminal Example: Router# configure terminal	Enters global configuration mode.
Step 3	voice hunt-group <i>hunt-tag</i> { parallel } Example: Router(config)# voice hunt-group 20 parallel	Creates a hunt group for phones in a Cisco Unified CME system. <ul style="list-style-type: none">• <i>hunt-tag</i>—Unique sequence number that identifies the hunt group. Range is 1 to 100.• parallel—Hunt group in which calls simultaneously ring multiple phones.
Step 4	final <i>number</i> Example: Router(config-voice-hunt-group)# final 4000	Defines the last extension in a voice hunt group. <ul style="list-style-type: none">• <i>number</i>—Telephone or extension number. Can be an E.164 number, voice-mail number, pilot number of another hunt group, or FXS caller-ID number.
Step 5	list <i>number</i> [, <i>number...</i>] Example: Router(config-voice-hunt-group)# list 3001, 3002, 3003	Defines a list of extensions that are members of a voice hunt group. <ul style="list-style-type: none">• <i>number</i>—Extension or E.164 number assigned to a phone in Cisco Unified CME. List must contain 2 to 32 numbers.
Step 6	timeout <i>seconds</i> Example: Router(config-voice-hunt-group)# timeout 20	Defines the number of seconds after which a call that is not answered is redirected to the next number in a voice hunt-group list. <ul style="list-style-type: none">• <i>seconds</i>—Number of seconds. Range is 3 to 60000. Default is 180.

	Command or Action	Purpose
Step 7	<p>pilot <i>number</i> [secondary <i>number</i>]</p> <p>Example:</p> <pre>Router(config-voice-hunt-group)# pilot 4045550110 secondary 3125550120</pre>	<p>Defines the number that callers dial to reach a Cisco Unified CME voice hunt group.</p> <ul style="list-style-type: none"> • <i>number</i>—String of up to 32 characters that represents an extension or E.164 telephone number. • secondary <i>number</i>—(Optional) Defines an additional pilot number for the voice hunt group.
Step 8	<p>name “<i>primary pilot name</i>” [secondary “<i>secondary pilot name</i>”]</p> <p>Example:</p> <pre>Router(config-voice-hunt-group)# name Hospital secondary "Health Center"</pre>	<p>Associates a name with the called voice hunt group.</p> <ul style="list-style-type: none"> • “<i>primary pilot name</i>”—Name for the primary pilot number. • secondary “<i>secondary pilot name</i>”—(Optional) Name for the secondary pilot number. <p>Note Use quotes (") when input strings have spaces in between.</p>

Prevent Local Call Forwarding to Final Agent in Voice Hunt-Groups

Before you begin

Cisco Unified CME 9.5 or a later version.

SUMMARY STEPS

1. **enable**
2. **configure terminal**
3. **voice hunt-group** *hunt-tag* {**parallel** | **sequential**}
4. [**no**] **forward local-calls to-final**

DETAILED STEPS

	Command or Action	Purpose
Step 1	<p>enable</p> <p>Example:</p> <pre>Router> enable</pre>	<p>Enables privileged EXEC mode.</p> <ul style="list-style-type: none"> • Enter your password if prompted.
Step 2	<p>configure terminal</p> <p>Example:</p> <pre>Router# configure terminal</pre>	<p>Enters global configuration mode.</p>
Step 3	<p>voice hunt-group <i>hunt-tag</i> {parallel sequential}</p> <p>Example:</p>	<p>Creates a hunt group for phones in a Cisco Unified CME system.</p>

	Command or Action	Purpose
	Router(config)# voice hunt-group 1 sequential	<ul style="list-style-type: none"> • hunt-tag—Unique sequence number that identifies the hunt group. Range is 1 to 100. • parallel—Hunt group in which calls simultaneously ring multiple phones. • sequential—Hunt group in which extensions ring in the order in which they are listed, left to right, when the hunt group was defined.
Step 4	<p>[no] forward local-calls to-final</p> <p>Example:</p> <pre>Router(config-voice-hunt-group)# no forward local-calls to-final</pre>	Prevents local calls from being forwarded to the final destination number.

Configure Night Service on SCCP Phones

This procedure defines night-service hours, an optional night-service code, the ephone-dns that trigger the notification process, and the ephones that will receive notification.



Restriction

- Night service notification is not supported on analog endpoints connected to FXS ports on a Cisco Integrated Services Router (ISR) or Cisco VG224 Analog Phone Gateway.
- In Cisco Unified CME 4.0 and later versions, silent ringing, configured on the phone by using the **s** keyword with the **button** command, is suppressed when used with the night service feature. Silent ringing is overridden and the phone audibly rings during designated night-service periods.

SUMMARY STEPS

1. **enable**
2. **configure terminal**
3. **telephony-service**
4. **night-service day** *day start-time stop-time*
5. **night-service date** *month date start-time stop-time*
6. **night-service everyday** *start-time stop-time*
7. **night-service weekday** *start-time stop-time*
8. **night-service weekend** *start-time stop-time*
9. **night-service code** *digit-string*
10. **timeouts night-service-bell** *seconds*
11. **exit**
12. **ephone-dn** *dn-tag*
13. **night-service bell**
14. **exit**
15. **ephone** *phone-tag*
16. **night-service bell**
17. **end**

DETAILED STEPS

	Command or Action	Purpose
Step 1	enable Example: Router> enable	Enables privileged EXEC mode. <ul style="list-style-type: none"> • Enter your password if prompted.
Step 2	configure terminal Example: Router# configure terminal	Enters global configuration mode.
Step 3	telephony-service Example: Router(config)# telephony-service	Enters telephony-service configuration mode.
Step 4	night-service day day start-time stop-time Example: Router(config-telephony)# night-service day mon 19:00 07:00	Defines a recurring time period associated with a day of the week during which night service is active. <ul style="list-style-type: none"> • <i>day</i>—Day of the week abbreviation. The following are valid day abbreviations: sun, mon, tue, wed, thu, fri, sat. • <i>start-time stop-time</i>—Beginning and ending times for night service, in an HH:MM format using a 24-hour clock. If the stop time is a smaller value than the start time, the stop time occurs the day following the start time. For example, “mon 19:00 07:00” means “from Monday at 7 p.m. until Tuesday at 7 a.m.”
Step 5	night-service date month date start-time stop-time Example: Router(config-telephony)# night-service date jan 1 00:00 00:00	Defines a recurring time period associated with a month and date during which night service is active. <ul style="list-style-type: none"> • <i>month</i>—Month abbreviation. The following are valid month abbreviations: jan, feb, mar, apr, may, jun, jul, aug, sep, oct, nov, dec. • <i>date</i>—Date of the month. Range is 1 to 31. • <i>start-time stop-time</i>—Beginning and ending times for night service, in an HH:MM format using a 24-hour clock. The stop time must be greater than the start time. The value 24:00 is not valid. If 00:00 is entered as a stop time, it is changed to 23:59. If 00:00 is entered for both start time and stop time, calls are blocked for the entire 24-hour period on the specified date.
Step 6	night-service everyday start-time stop-time Example:	Defines a recurring night-service time period to be effective everyday. <ul style="list-style-type: none"> • <i>start-time stop-time</i>—Beginning and ending times for night service, in an HH:MM format using a

	Command or Action	Purpose
	<pre>Router(config-telephony)# night-service everyday 1200 1300</pre>	<p>24-hour clock. If the stop time is a smaller value than the start time, the stop time occurs the day following the start time. For example, “19:00 07:00” means “from 7 p.m. to 7 a.m. the next morning.” The value 24:00 is not valid. If 00:00 is entered as a stop time, it is changed to 23:59. If 00:00 is entered for both start time and stop time, the night service feature will be activated for the entire 24-hour period.</p>
Step 7	<p>night-service weekday <i>start-time stop-time</i></p> <p>Example:</p> <pre>Router(config-telephony)# night-service weekday 1700 0700</pre>	<p>Defines a recurring night-service time period to be effective on all weekdays.</p> <ul style="list-style-type: none"> • <i>start-time stop-time</i>—Beginning and ending times for night service, in an HH:MM format using a 24-hour clock. If the stop time is a smaller value than the start time, the stop time occurs the day following the start time. For example, “19:00 07:00” means “from 7 p.m. to 7 a.m. the next morning.” The value 24:00 is not valid. If 00:00 is entered as a stop time, it is changed to 23:59. If 00:00 is entered for both start time and stop time, the night service feature will be activated for the entire 24-hour period.
Step 8	<p>night-service weekend <i>start-time stop-time</i></p> <p>Example:</p> <pre>Router(config-telephony)# night-service weekend 00:00 00:00</pre>	<p>Defines a recurring night-service time period to be effective on all weekend days (Saturday and Sunday).</p> <ul style="list-style-type: none"> • <i>start-time stop-time</i>—Beginning and ending times for night service, in an HH:MM format using a 24-hour clock. If the stop time is a smaller value than the start time, the stop time occurs the day following the start time. For example, “19:00 07:00” means “from 7 p.m. to 7 a.m. the next morning.” The value 24:00 is not valid. If 00:00 is entered as a stop time, it is changed to 23:59. If 00:00 is entered for both start time and stop time, the night service feature will be activated for the entire 24-hour period.
Step 9	<p>night-service code <i>digit-string</i></p> <p>Example:</p> <pre>Router(config-telephony)# night-service code *6483</pre>	<p>Designates a code that can be dialed from any night-service line (ephone-dn) to toggle night service on and off for all lines assigned to night service in the system.</p> <ul style="list-style-type: none"> • <i>digit-string</i>—String of up to 16 keypad digits. The code must begin with an asterisk (*).
Step 10	<p>timeouts night-service-bell <i>seconds</i></p> <p>Example:</p> <pre>Router(config-telephony)# timeouts night-service-bell 15</pre>	<p>Defines the frequency of the night-service notification.</p> <ul style="list-style-type: none"> • <i>seconds</i>—Range: 4 to 30. Default: 12.

	Command or Action	Purpose
Step 11	exit Example: Router(config-telephony)# exit	Exits telephony-service configuration mode.
Step 12	ephone-dn dn-tag Example: Router(config)# ephone-dn 55	Enters ephone-dn configuration mode to define an ephone-dn to receive night-service treatment.
Step 13	night-service bell Example: Router(config-ephone-dn)# night-service bell	Marks this ephone-dn for night-service treatment.
Step 14	exit Example: Router(config-ephone-dn)# exit	Exits ephone-dn configuration mode.
Step 15	ephone phone-tag Example: Router(config)# ephone 12	Enters ephone configuration mode. <ul style="list-style-type: none">• <i>phone-tag</i>—The unique sequence number of the phone that will be notified when an incoming call is received by a night-service ephone-dn during a night-service period.
Step 16	night-service bell Example: Router(config-ephone)# night-service bell	Marks this phone to receive night-service bell notification when incoming calls are received on ephone-dns marked for night service during the night-service time period. <ul style="list-style-type: none">• Night service notification is not supported on analog endpoints connected to SCCP FXS ports on a Cisco ISR or Cisco VG224.
Step 17	end Example: Router(config-ephone)# end	Returns to privileged EXEC mode.

Configure Night Service on SIP Phones

This procedure defines night-service hours, an optional night-service code, the voice register DN's that trigger the notification process, and the SIP phones (voice register pools) that receive notification. The CLI commands related to night-service in telephony-service are used to make night service feature work on SIP phones.



Restriction

- When **service directed-pickup gpickup** is configured under telephony service, gpickup softkey has to be used on SCCP phones to pick up the ringing call on night-service extensions.

Before you begin

- It is mandatory to configure the CLI command **service directed-pickup gpickup** under telephony-service to pick up calls from SIP phones for night service.
- It is mandatory to configure the CLI command **call-park system application** under telephony-service to enable or disable Night Service functionality using night service code on SIP phones.
- It is mandatory to configure source IP address, port, and max dn under telephony-service configuration to make night service feature work for SIP phones.

SUMMARY STEPS

1. **enable**
2. **configure terminal**
3. **telephony-service**
4. **night-service day** *day start-time stop-time*
5. **night-service date** *month date start-time stop-time*
6. **night-service everyday** *start-time stop-time*
7. **night-service weekday** *start-time stop-time*
8. **night-service weekend** *start-time stop-time*
9. **fac standard**
10. **night-service code** *digit-string*
11. **call-park system application**
12. **service directed-pickup gpickup**
13. **timeouts night-service-bell** *seconds*
14. **exit**
15. **voice register dn** *dn-tag*
16. **night-service bell**
17. **exit**
18. **voice register pool** *pool -tag* | **voice register template** *template-tag*
19. **night-service bell**
20. **voice register pool** *pool-tag*
21. **template** *template-tag*
22. **end**

DETAILED STEPS

	Command or Action	Purpose
Step 1	enable Example: Router> enable	Enables privileged EXEC mode. <ul style="list-style-type: none"> • Enter your password if prompted.
Step 2	configure terminal Example: Router# configure terminal	Enters global configuration mode.

	Command or Action	Purpose
Step 3	telephony-service Example: <pre>Router(config)# telephony-service</pre>	Enters telephony-service configuration mode.
Step 4	night-service day <i>day start-time stop-time</i> Example: <pre>Router(config-telephony)# night-service day mon 19:00 07:00</pre>	Defines a recurring time period associated with a day of the week during which night service is active. <ul style="list-style-type: none"> • <i>day</i>—Day of the week abbreviation. The following are valid day abbreviations: sun, mon, tue, wed, thu, fri, sat. • <i>start-time stop-time</i>—Beginning and ending times for night service, in an HH:MM format using a 24-hour clock. If the stop time is a smaller value than the start time, the stop time occurs the day following the start time. For example, “mon 19:00 07:00” means “from Monday at 7 p.m. until Tuesday at 7 a.m.”
Step 5	night-service date <i>month date start-time stop-time</i> Example: <pre>Router(config-telephony)# night-service date jan 1 00:00 00:00</pre>	Defines a recurring time period associated with a month and date during which night service is active. <ul style="list-style-type: none"> • <i>month</i>—Month abbreviation. The following are valid month abbreviations: jan, feb, mar, apr, may, jun, jul, aug, sep, oct, nov, dec. • <i>date</i>—Date of the month. Range is 1 to 31. • <i>start-time stop-time</i>—Beginning and ending times for night service, in an HH:MM format using a 24-hour clock. The stop time must be greater than the start time. The value 24:00 is not valid. If 00:00 is entered as a stop time, it is changed to 23:59. If 00:00 is entered for both start time and stop time, calls are blocked for the entire 24-hour period on the specified date.
Step 6	night-service everyday <i>start-time stop-time</i> Example: <pre>Router(config-telephony)# night-service everyday 1200 1300</pre>	Defines a recurring night-service time period to be effective everyday. <ul style="list-style-type: none"> • <i>start-time stop-time</i>—Beginning and ending times for night service, in an HH:MM format using a 24-hour clock. If the stop time is a smaller value than the start time, the stop time occurs the day following the start time. For example, “19:00 07:00” means “from 7 p.m. to 7 a.m. the next morning.” The value 24:00 is not valid. If 00:00 is entered as a stop time, it is changed to 23:59. If 00:00 is entered for both start time and stop time, the night service feature will be activated for the entire 24-hour period.

	Command or Action	Purpose
Step 7	<p>night-service weekday <i>start-time stop-time</i></p> <p>Example:</p> <pre>Router(config-telephony)# night-service weekday 1700 0700</pre>	<p>Defines a recurring night-service time period to be effective on all weekdays.</p> <ul style="list-style-type: none"> • <i>start-time stop-time</i>—Beginning and ending times for night service, in an HH:MM format using a 24-hour clock. If the stop time is a smaller value than the start time, the stop time occurs the day following the start time. For example, “19:00 07:00” means “from 7 p.m. to 7 a.m. the next morning.” The value 24:00 is not valid. If 00:00 is entered as a stop time, it is changed to 23:59. If 00:00 is entered for both start time and stop time, the night service feature will be activated for the entire 24-hour period.
Step 8	<p>night-service weekend <i>start-time stop-time</i></p> <p>Example:</p> <pre>Router(config-telephony)# night-service weekend 00:00 00:00</pre>	<p>Defines a recurring night-service time period to be effective on all weekend days (Saturday and Sunday).</p> <ul style="list-style-type: none"> • <i>start-time stop-time</i>—Beginning and ending times for night service, in an HH:MM format using a 24-hour clock. If the stop time is a smaller value than the start time, the stop time occurs the day following the start time. For example, “19:00 07:00” means “from 7 p.m. to 7 a.m. the next morning.” The value 24:00 is not valid. If 00:00 is entered as a stop time, it is changed to 23:59. If 00:00 is entered for both start time and stop time, the night service feature will be activated for the entire 24-hour period.
Step 9	<p>fac standard</p> <p>Example:</p> <pre>Router(config-telephony)# fac standard</pre>	<p>(Optional) Enables predefined standard feature access codes (FACs) to be enabled. For the CLI command night-service code to work, it is mandatory to configure fac standard under telephony-service configuration mode.</p>
Step 10	<p>night-service code <i>digit-string</i></p> <p>Example:</p> <pre>Router(config-telephony)# night-service code *6483</pre>	<p>Designates a code that can be dialed from any night-service line (voice register dn) to toggle night service on and off for all lines assigned to night service in the system.</p> <ul style="list-style-type: none"> • <i>digit-string</i>—String of up to 16 keypad digits. The code must begin with an asterisk (*).
Step 11	<p>call-park system application</p> <p>Example:</p> <pre>Router(config-telephony)# call-park system application</pre>	<p>Enables or disables Night Service functionality using night service code on SIP phones.</p>
Step 12	<p>service directed-pickup gpickup</p> <p>Example:</p> <pre>Router(config-telephony)# service directed-pickup gpickup</pre>	<p>Enables Directed Call Pickup and modifies the function of the GPickUp and PickUp soft keys.</p>

	Command or Action	Purpose
Step 13	timeouts night-service-bell <i>seconds</i> Example: Router(config-telephony)# timeouts night-service-bell 15	Defines the frequency of the night-service notification. <ul style="list-style-type: none">• <i>seconds</i>—Range: 4 to 30. Default: 12.
Step 14	exit Example: Router(config-telephony)# exit	Exits telephony-service configuration mode.
Step 15	voice register dn <i>dn-tag</i> Example: Router(config)# voice register dn 10	Enters voice register dn configuration mode to define a voice register dn to receive night-service treatment.
Step 16	night-service bell Example: Router(config-register-dn)# night-service bell	Marks this voice register dn for night-service treatment.
Step 17	exit Example: Router(config-register-dn)# exit	Exits voice register dn configuration mode.
Step 18	voice register pool <i>pool -tag</i> voice register template <i>template-tag</i> Example: Router(config)# voice register pool 10 Router(config)# voice register template 1	Enters pool configuration mode (or template configuration mode). <ul style="list-style-type: none">• <i>pool-tag</i>—The unique sequence number of the phone that will be notified when an incoming call is received by a night-service voice-dn during a night-service period.
Step 19	night-service bell Example: Router(config-register-pool)# night-service bell Router(config-register-template)# night-service bell	Marks this phone to receive night-service bell notification when incoming calls are received on voice register dns marked for night service during the night-service time period.
Step 20	voice register pool <i>pool-tag</i> Example: Router(config)# voice register pool 10	Enters pool configuration mode. This step is valid only when the night service configuration is under voice register template.
Step 21	template <i>template-tag</i> Example: Router(config-register-pool)# template 1	Includes the template with night-service bell configured to provide night service treatment for this pool. This step is valid only when the night service configuration is under voice register template.
Step 22	end Example:	Returns to privileged EXEC mode.

	Command or Action	Purpose
	Router(config-register-temp)# end	

Verify Night Service Configuration on SCCP Phones

Step 1 Use the **show running-config** command to verify the night-service parameters, which are listed in the telephony-service portion of the output, or use the **show telephony-service** command to display the same parameters.

Example:

```
Router# show running-config
```

```
telephony-service
fxo hook-flash
load 7910 P00403020214
load 7960-7940 P00303020214
max-ephones 48
max-dn 288
ip source-address 10.50.50.1 port 2000
application segway0
caller-id block code *321
create cnf-files version-stamp 7960 Mar 07 2003 11:19:18
voicemail 79000
max-conferences 8
call-forward pattern .....
moh minuet.wav
date-format yy-mm-dd
transfer-system full-consult
transfer-pattern .....
secondary-dialtone 9
night-service code *1234
night-service day Tue 00:00 23:00
night-service day Wed 01:00 23:59
!
```

```
Router# show telephony-service
```

```
CONFIG (Version=4.0(0))
=====
Version 4.0(0)
```

Cisco Unified CallManager Express

For on-line documentation please see:

www.cisco.com/en/US/products/sw/voicesw/tsd_products_support_category_home.html

```
ip source-address 10.103.3.201 port 2000
load 7910 P00403020214
load 7961 TERM41.7-0-1-1
load 7961GE TERM41.7-0-1-1
load 7960-7940 P00307020300
max-ephones 100
max-dn 500
max-conferences 8 gain -6
dspfarm units 2
dspfarm transcode sessions 4
dspfarm 1 MTP00059a3d7441
dspfarm 2
hunt-group report delay 1 hours
Number of hunt-group configured: 14
hunt-group logout DND
max-redirect 20
voicemail 7189
cnf-file location: system:
cnf-file option: PER-PHONE-TYPE
network-locale[0] US    (This is the default network locale for this box)
user-locale[0] US     (This is the default user locale for this box)
moh flash:music-on-hold.au
time-format 12
date-format mm-dd-yy
timezone 0 Greenwich Standard Time
secondary-dialtone 9
call-forward pattern .T
transfer-pattern 92.....
transfer-pattern 91.....
transfer-pattern .T
after-hours block pattern 1 91900 7-24
after-hours block pattern 2 9976 7-24
after-hours block pattern 4 91...976.... 7-24
night-service time is activated
night-service date Jan 1 00:00 23:59
night-service day Mon 17:00 07:00
```

```
night-service day Wed 17:00 07:00
keepalive 30
timeout interdigit 10
timeout busy 10
timeout ringing 100
caller-id name-only: enable
system message XYZ Company
web admin system name xyz password xxxx
web admin customer name Customer
edit DN through Web: enabled.
edit TIME through web: enabled.
Log (table parameters):
    max-size: 150
    retain-timer: 15
create cnf-files version-stamp Jan 01 2002 00:00:00
transfer-system full-consult
multicast moh 239.10.10.1 port 2000
fxo hook-flash
local directory service: enabled.
```

Step 2 Use the **show running-config** command to verify that the correct ephone-dns and ephones are configured with the **night-service bell** command. You can also use the **show telephony-service ephone-dn** and **show telephony-service ephone** commands to display these parameters.

Example:

```
Router# show running-config
```

```
ephone-dn 24 dual-line
    number 2548
    description FrontDesk
    night-service bell

ephone 1
    mac-address 110F.80C0.FE0B
    type 7960 addon 1 7914
    no dnd feature-ring
    keep-conference
    button 1f40 2f41 3f42 4:30
    button 7m20 8m21 9m22 10m23
    button 11m24 12m25 13m26
```

```
night-service bell
```

Verify Night Service Configuration on SIP Phones

Step 1 Use the **show running-config | section telephony-service** command to verify the night-service parameters that are listed in the telephony-service portion of the output. Use the **show telephony-service** command to display the same parameters.

Example:

```
Router# show running-config | section telephony-service
```

```
telephony-service
max-ephones 50
max-dn 50
ip source-address 10.50.50.1 port 2000
service phone sshAccess 0
service phone webAccess 0
service directed-pickup gpickup
time-zone 39
max-conferences 8 gain -6
call-park system application
hunt-group report url suffix 0 to 100
hunt-group report every 1 hours
hunt-group logout HLog
transfer-system full-consult
night-service weekday 13:17 14:17
night-service day Sun 00:05 23:59
night-service day Sat 00:05 23:59
night-service code *6483
```

```
Router# show telephony-service
```

```
max-ephones 50
max-dn 50
ip source-address 10.50.50.1 port 2000
service phone sshAccess 0
service phone webAccess 0
time-zone 39
max-conferences 8 gain -6
call-park system application
hunt-group report url suffix 0 to 100
hunt-group report every 1 hours
hunt-group logout HLog
transfer-system full-consult
night-service time is activated
night-service weekday 13:17 14:17
night-service day Sun 00:05 23:59
night-service day Sat 00:05 23:59
```

Step 2 Use the **show voice register dn** and **show voice register pool** command to verify that the correct voice register dns and phones are configured with the **night-service bell** command.

Example:

```
Router# show voice register dn 1
```



```

Dn Tag 1
Config:
Number is 8001
Preference is 0
Huntstop is disabled
Auto answer is disabled
Pickup group is 5
Night Service Bell is enabled

Router# show voice register pool 5

Pool Tag 5
Config:
Mac address is B000.B4BE.F32C
Type is 8851
Number list 1 : DN 5
Proxy Ip address is 0.0.0.0
DTMF Relay is disabled
Call Waiting is enabled
DnD is disabled
Video is disabled
Camera is disabled
Night Service Bell is enabled
Busy trigger per button value is 2

```

Configure Overlaid Ephone-dns on SCCP Phones

To create ephone-dns, then assign multiple ephone-dns to a single phone button by using the **o** or **c** keyword with the **button** command, perform the following steps.



Restriction

- Call waiting is disabled when you configure ephone-dn overlays using the **o** keyword with the **button** command. To enable call waiting, you must configure ephone-dn overlays using the **c** keyword with the **button** command.
- Rollover of overlay calls to another phone button by using the **x** keyword with the **button** command only works to expand coverage if the overlay button is configured with the **o** keyword in the **button** command. Overlay buttons with call waiting that use the **c** keyword in the **button** command are not eligible for overlay rollover.
- In Cisco Unified CME 4.0(3), the Cisco Unified IP Phone 7931G cannot support overlays that contain ephone-dn configured for dual-line mode.
- The primary ephone-dn on each phone in a shared-line overlay set should be an ephone-dn that is unique to the phone to guarantee that the phone will have a line available for outgoing calls, and to ensure that the phone user can obtain dial-tone even when there are no idle lines available in the rest of the shared-line overlay set. Use a unique ephone-dn in this manner to provide for a unique calling party identity on outbound calls made by the phone so that the called user can see which specific phone is calling.
- Octo-line directory numbers are not supported in button overlay sets.

SUMMARY STEPS

1. **enable**
2. **configure terminal**
3. **ephone-dn** *phone-tag* [**dual-line**]
4. **number** *number*
5. **preference** *preference-order*
6. **no huntstop** or **huntstop**
7. **huntstop channel**
8. **call-forward noan**
9. **call-forward busy**
10. **exit**
11. **ephone** *phone-tag*
12. **mac-address** *mac-address*
13. **button** *button-number* {**o** | **c**}*dn-tag, dn-tag* [, *dn-tag...*] *button-number* {**x**} *overlay-button-number*
14. **end**

DETAILED STEPS

	Command or Action	Purpose
Step 1	enable Example: Router> enable	Enables privileged EXEC mode. <ul style="list-style-type: none">• Enter your password if prompted.
Step 2	configure terminal Example: Router# configure terminal	Enters global configuration mode.
Step 3	ephone-dn <i>phone-tag</i> [dual-line] Example: Router(config)# ephone-dn 10 dual-line	Enters ephone-dn configuration mode to create an extension (ephone-dn) for a Cisco Unified IP phone line. <ul style="list-style-type: none">• For shared-line overlay set: Primary ephone-dn on a phone should be an ephone-dn that is unique to the phone.
Step 4	number <i>number</i> Example: Router(config-ephone-dn)# number 1001	Associates a telephone or extension number with the ephone-dn.
Step 5	preference <i>preference-order</i> Example: Router(config-ephone-dn)# preference 1	Sets dial-peer preference order for an ephone-dn. <ul style="list-style-type: none">• <i>preference-order</i>—Preference order for the primary number associated with an extension (ephone-dn). Type ? for a range of numeric options, where 0 is the highest preference. Default: 0.
Step 6	no huntstop or huntstop Example:	Explicitly enables call hunting behavior for a directory number.

	Command or Action	Purpose
	<pre>Router(config-ephone-dn) # no huntstop or Router(config-ephone-dn) # huntstop</pre>	<ul style="list-style-type: none"> Set this command on all ephone-dns in the overlay set except the final instance. Required to allow call hunting allow call hunting across multiple numbers on the same line button on an IP phone. <p>or</p> <p>Disables call hunting behavior for a directory number.</p> <ul style="list-style-type: none"> Set this command on the last ephone-dn within a overlay set. Required to limit the call hunting to an overlay set.
Step 7	<p>huntstop channel</p> <p>Example:</p> <pre>Router(config-ephone-dn) # huntstop channel</pre>	<p>Only for dual-line ephone-dns in overlay set; keeps incoming calls from hunting to the second channel if the first channel is busy or does not answer.</p> <ul style="list-style-type: none"> Reserves the second channel for outgoing calls, such as a consultation call to be placed during a call transfer attempt, or for conferencing
Step 8	<p>call-forward noan</p> <p>Example:</p> <pre>Router(config-ephone-dn) # call-forward noan</pre>	<p>(Optional) Forwards incoming unanswered call to next line in the overlay set.</p> <ul style="list-style-type: none"> Set this command on all ephone-dns in the overlay set.
Step 9	<p>call-forward busy</p> <p>Example:</p> <pre>Router(config-ephone-dn) # call-forward busy</pre>	<p>(Optional) Forwards incoming call if line is busy.</p> <ul style="list-style-type: none"> Set this command on the last ephone-dn in the overlay set only.
Step 10	<p>exit</p> <p>Example:</p> <pre>Router(config-ephone-dn) # exit</pre>	Exits ephone-dn configuration mode
Step 11	<p>ephone <i>phone-tag</i></p> <p>Example:</p> <pre>Router(config) # ephone 4</pre>	<p>Enters ephone configuration mode.</p> <ul style="list-style-type: none"> <i>phone-tag</i>—Unique sequence number that identifies the phone to which you are adding an overlay set.
Step 12	<p>mac-address <i>mac-address</i></p> <p>Example:</p> <pre>Router(config-ephone) # mac-address 1234.5678.abcd</pre>	Specifies the MAC address of the registering phone.
Step 13	<p>button <i>button-number</i> {o c} <i>dn-tag, dn-tag</i> [, <i>dn-tag</i>...] <i>button-number</i> {x} <i>overlay-button-number</i></p>	Creates a set of ephone-dns overlaid on a single button.

	Command or Action	Purpose
	<p>Example:</p> <pre>Router(config-ephone)# button 1o15,16,17,18,19 2c20,21,22 3x1 4x1</pre>	<ul style="list-style-type: none"> • o—Overlay button. Multiple ephone-dns share this button. A maximum of 25 ephone-dns can be specified for a single button, separated by commas. • c—Overlay button with call-waiting. Multiple ephone-dns share this button. A maximum of 25 ephone-dns can be specified for a single button, separated by commas. • x—Separator that creates a rollover button for an overlay button that was defined using the o keyword. When the overlay button specified in this command is occupied by an active call, a second call to one of its ephone-dns will be presented on this button. • <i>dn-tag</i>—Unique identifier previously defined with the ephone-dn command for the ephone-dn to be added to this overlay set. • <i>overlay-button-number</i>—Number of the overlay button that should overflow to this button. Note that the button must have been defined using the o keyword and not the c keyword. <p>Note For other keywords, see the button command in the Cisco Unified Communications Manager Express Command Reference.</p>
<p>Step 14</p>	<p>end</p> <p>Example:</p> <pre>Router(config-ephone)# end</pre>	<p>Returns to privileged EXEC mode.</p>

Verify Overlaid Ephone-dns Configuration on SCCP Phone

Step 1 Use the **show running-config** command or the **show telephony-service ephone** command to view button assignments.

```
Router# show running-config

ephone 5
  description Cashier1
  mac-address 0117.FBC6.1985
  type 7960
  button 1o4,5,6,200,201,202,203,204,205,206 2x1 3x1
```

Step 2 Use the **show ephone overlay** command to display the configuration and current status of registered overlay ephone-dns.

- Step 3** Use the **show dialplan number** command to display all the number resolutions of a particular phone number, which allows you to detect whether calls are going to unexpected destinations. This command is useful for troubleshooting cases in which you dial a number but the expected phone does not ring.

Enable Out-Of-Dialog REFER



- Restriction**
- The call waiting, conferencing, hold, and transfer call features are not supported while the Refer-Target is ringing.
 - In a SIP to SIP scenario, no ringback is heard by the Referee when Refer-Target is ringing.

Before you begin

- Cisco Unified CME 4.1 or a later version.
- The application that initiates OOD-R, such as a click-to-dial application, and its directory server must be installed and configured.
- For information on the SIP REFER and NOTIFY methods used between the directory server and Cisco Unified CME, see [RFC 3515](#), The Session Initiation Protocol (SIP) Refer Method.
- For information on the message flow Cisco Unified CME uses when initiating a session between the Referee and Refer-Target, see [RFC 3725](#), Best Current Practices for Third Party Call Control (3pcc).

SUMMARY STEPS

1. **enable**
2. **configure terminal**
3. **sip-ua**
4. **refer-ood enable** [*request-limit*]
5. **exit**
6. **voice register global**
7. **authenticate ood-refer**
8. **authenticate credential** *tag location*
9. **end**

DETAILED STEPS

	Command or Action	Purpose
Step 1	enable Example: Router> enable	Enables privileged EXEC mode. <ul style="list-style-type: none"> • Enter your password if prompted.
Step 2	configure terminal Example:	Enters global configuration mode.

	Command or Action	Purpose
	Router# configure terminal	
Step 3	sip-ua Example: Router(config)# sip-ua	Enters SIP user-agent configuration mode to configure the user agent.
Step 4	refer-ood enable [<i>request-limit</i>] Example: Router(config-sip-ua)# refer-ood enable 300	Enables OOD-R processing. <ul style="list-style-type: none"> <i>request-limit</i>—Maximum number of concurrent incoming OOD-R requests that the router can process. Range: 1 to 500. Default: 500.
Step 5	exit Example: Router(config-sip-ua)# exit	Exits SIP user-agent configuration mode.
Step 6	voice register global Example: Router(config)# voice register global	Enters voice register global configuration mode to set global parameters for all supported SIP phones in a Cisco Unified CME or Cisco Unified SRST environment.
Step 7	authenticate ood-refer Example: Router(config-register-global)# authenticate ood-refer	(Optional) Enables authentication of incoming OOD-R requests using RFC 2617-based digest authentication.
Step 8	authenticate credential <i>tag location</i> Example: Router(config-register-global)# authenticate credential 1 flash:cred1.csv	(Optional) Specifies the credential file to use for authenticating incoming OOD-R requests. <ul style="list-style-type: none"> <i>tag</i>—Number that identifies the credential file to use for OOD-R authentication. Range: 1 to 5. <i>location</i>—Name and location of the credential file in URL format. Valid storage locations are TFTP, HTTP, and flash memory.
Step 9	end Example: Router(config-register-global)# end	Exits to privileged EXEC mode.

What to do next

- If you are configuring Cisco Unified CME for the first time on this router, you are ready to configure system-level parameters. See [Configure System-Level Parameters](#).
- If you modified network parameters for an already configured Cisco Unified CME router, you are ready to generate the configuration file to save the modifications. See [Generate Configuration Files for Phones](#).

Verify OOD-R Configuration

SUMMARY STEPS

1. `show running-config`
2. `show sip-ua status refer-ood`

DETAILED STEPS

Step 1 `show running-config`

This command verifies your configuration.

Example:

```
Router# show running-config
!
voice register global
mode cme
source-address 10.1.1.2 port 5060
load 7971 SIP70.8-0-1-11S
load 7970 SIP70.8-0-1-11S
load 7961GE SIP41.8-0-1-0DEV
load 7961 SIP41.8-0-1-0DEV
authenticate ood-refer
authenticate credential 1 tftp://172.18.207.15/labtest/cred1.csv
create profile sync 0004550081249644
.
.
sip-ua
refer-ood enable
```

Step 2 `show sip-ua status refer-ood`

This command displays OOD-R configuration settings.

Example:

```
Router# show sip-ua status refer-ood

Maximum allow incoming out-of-dialog refer 500
Current existing incoming out-of-dialog refer dialogs: 1
outgoing out-of-dialog refer dialogs: 0
```

Troubleshooting OOD-R

-
- Step 1** Use the `debug ccsip messages` command to display the SIP messages exchanged between the SIP UA client and the router.

Step 2 Use the `debug voip application oodrefer` command to display debugging messages for the OOD-R feature.

Configuration Examples for Call Coverage Features

Call Hunt: Examples

Example for Setting Ephone-dn Dial-Peer Preference

The following example sets a preference number of 2 for the primary number of ephone-dn 3:

```
ephone-dn 3
  number 3001
  preference 2
```

Example for Disabling Huntstop

The following example shows an instance in which huntstop is not desired and is explicitly disabled. In this example, ephone 4 is configured with two lines, each with the same extension number 5001. This is done to allow the second line to provide call waiting notification for extension number 5001 when the first line is in use. Setting **no huntstop** on the first line (ephone-dn 1) allows incoming calls to hunt to the second line (ephone-dn 2) on the same phone when the ephone-dn 1 line is busy.

Ephone-dn 2 has call forwarding set to extension 6000, which corresponds to a locally attached answering machine connected to a foreign exchange station (FXS) voice port. The plain old telephone service (POTS) dial peer for extension 6000 also has the dial-peer huntstop attribute explicitly set to prevent further hunting.

```
ephone-dn 1
  number 5001
  no huntstop
  preference 1
  call-forward noan 6000

ephone-dn 2
  number 5001
  preference 2
  call-forward busy 6000
  call-forward noan 6000

ephone 4
  button 1:1 2:2
  mac-address 0030.94c3.8724
  dial-peer voice 6000 pots
  destination-pattern 6000
  huntstop port 1/0/0
  description answering-machine
```

Example for Channel Huntstop

The following is an example that uses the **huntstop channel** command. It shows a dual-line ephone-dn configuration in which calls do not hunt to the second channel of any ephone-dn, but they do hunt through each ephone-dn's channel 1 in this order: ephone-dn 10, ephone-dn 11, ephone-dn 12.

```
ephone-dn 10 dual-line
  number 1001
  no huntstop
  huntstop channel
```

```
ephone-dn 11 dual-line
  number 1001
  no huntstop
  huntstop channel
  preference 1
```

```
ephone-dn 12 dual-line
  number 1001
  no huntstop
  huntstop channel
  preference 2
```

Example for SIP Call Hunt

The following example shows a typical configuration in which huntstop is required. The **huntstop** command is enabled and prevents calls to extension 5001 from being rerouted to the on-net H.323 dial peer for 5... when extension 5001 is busy (three periods are used as wild cards).

```
voice register dn 1
  number 5001
  huntstop

voice register pool 4
  number 1 dn 1
  id-mac 0030.94c3.8724

dial-peer voice 5000 voip
  destination-pattern 5...
  session target ipv4:192.168.17.225
  session protocol sipv2
```

Example for Call Pickup

The following example assigns the line that has an ephone-dn tag of 55 to pickup group 2345:

Example for Call-Waiting Beep

```
ephone-dn 55
  number 2555
  pickup-group 2345
```

The following example globally disables directed call pickup and changes the action of the PickUp soft key to perform local group call pickup rather than directed call pickup:

```
telephony-service
  no service directed-pickup
```

Example for Call-Waiting Beep

In the following example, ephone-dn 10 neither accepts nor generates a beep, ephone-dn 11 does not accept a beep, and ephone-dn 12 does not generate a beep:

```
ephone-dn 10
  no call-waiting beep
  number 4410

ephone-dn 11
  no call-waiting beep accept
  number 4411

ephone-dn 12
  no call-waiting beep generate
  number 4412
```

Example for Call-Waiting Ring

The following example specifies that a short ring will indicate a call is waiting for extension 5533:

```
ephone-dn 20
  number 5533
  call-waiting ring
```

Examples for Hunt Group**Example for Sequential Ephone-Hunt Group**

The following example defines a sequential ephone hunt group with the pilot number 5600 and the final number 6000, with three numbers in the list of phones that answer for the pilot number:

```
ephone-hunt 2 sequential
  pilot 5600
  list 5621, *, 5623
  final 6000
  max-timeout 10
  timeout 20, 20, 20
```

```
fwd-final orig-phone
```

Example for Peer Ephone-Hunt Group

The following example defines peer ephone hunt group 10 with a pilot number 450, a final number 500, and four numbers in the list. After a call is redirected four times (makes four hops), it is redirected to the final number.

```
ephone-hunt 10 peer
pilot 450
list 451, 452, 453, 477
final 500
max-timeout 10
timeout 3, 3, 3, 3
```

Example for Longest-idle Ephone-Hunt Group

The following example defines longest-idle ephone hunt group 1 with a pilot number 7501 and 11 numbers in the list. After a call is redirected five times, it is redirected to the final number.

```
ephone-hunt 1 longest-idle
pilot 7501
list 7001, 7002, 7023, 7028, 7045, 7062, 7067, 7072, 7079, 7085, 7099
final 8000
preference 1
hops 5
timeout 20
no-reg
```

Example for Longest-idle Ephone-Hunt Group Using From-Ring Option

The following example defines longest-idle ephone hunt group 1 with a pilot number 7501, a final number 8000, and 11 numbers in the list. Because the **from-ring** command is used, on-hook time stamps will be recorded when calls ring extensions and when calls are answered. After a call is redirected six times (makes six hops), it is redirected to the final number, 8000. The **max-redirect** command is used to increase the number of redirects that are allowed because the number of hops (six) is larger than the default number of redirects that are allowed in the system (five).

```
ephone-hunt 1 longest-idle
pilot 7501
list 7001, 7002, 7023, 7028, 7045, 7062, 7067, 7072, 7079, 7085, 7099
final 8000
from-ring
preference 1
hops 6
timeout 20

telephony-service
```

```
max-redirect 8
```

Example for Sequential Hunt Group

In the following parallel hunt-group example, when callers dial extension 1000, extension 1001, 1002, 1003, and 1004 ring simultaneously. The first extension to answer is connected. If none of the extensions answers within 60 seconds, the call is forwarded to extension 2000, which is the number for voice mail.

```
voice hunt-group 4 parallel
  final 2000
  list 1001,1002,1003,1004
  timeout 60
  pilot 1000
  preference 1 secondary 9
  !
  !
  ephone-dn 1 octo-line
    number 1001
  !
  ephone-dn 2
    number 1002
  !
  ephone-dn 3 dual-line
    number 1003
  !
  ephone-dn 4
    number 1004
  !
  !
  ephone 1
    max-calls-per-button 4
    mac-address 02EA.EAEA.0001
    button 1:1
  !
  !
  ephone 2
    mac-address 001C.821C.ED23
    button 1:2
  !
  !
  ephone 3
    mac-address 002D.264E.54FA
```

```

button 1:3
!
!
ephone 4
  mac-address 0030.94C3.053E
  button 1:4

```

Example for Preventing Local Call Forwarding in Parallel Voice Hunt-Groups

The following example shows how to prevent the forwarding of local calls to the final destination in parallel voice hunt-group 1:

```

Router# configure terminal
Router(config)# voice hunt-group 1 parallel
Router(config-voice-hunt-group)# no forward local-calls to-final

```

Example for Associating a Name with a Called Voice Hunt-Group

When incoming call A reaches voice hunt group B and lands on final C, extension C does not show the name of the forwarder because the voice hunt group is not configured to display the name. To display the name of the forwarder and the final number, two separate names are required for the primary and secondary pilot numbers.

ephone-hunt

The following is a sample output of the **show run** command when the primary and secondary pilot names are configured in ephone-hunt configuration mode:

```

ephone-hunt 10 sequential
  pilot 1010 secondary 1020
  list 2004, 2005
  final 2006
  timeout 8, 8
  name "EHUNT PRIMARY" secondary "EHUNT SECONDARY"

ephone-hunt 11 peer
  pilot 1012 secondary 1022
  list 2004, 2005
  final 2006
  timeout 8, 8
  name EHUNT1 secondary EHUNT1-SEC

```

The following is a sample output of the **show ephone-hunt** command when the primary and secondary pilot names are configured in ephone-hunt configuration mode:

```

show ephone-hunt 10
Group 10
type: sequential
pilot number: 1010, peer-tag 20010
pilot name: EHUNT PRIMARY
secondary number: 1020, peer-tag 20011
secondary name: EHUNT SECONDARY

```

voice hunt-group

The following example shows how the primary and secondary pilot names are configured in voice hunt-group configuration mode:

Example for Specifying a Description for a Voice Hunt-Group

```
voice hunt-group 24 parallel
final 097
list 885,886,124,154
timeout 20
pilot 021 secondary 621
name SALES secondary SALES-SECONDARY
```

The following is a sample output of the **show voice hunt-group** command when the primary and secondary pilot names are configured in voice hunt-group configuration mode:

```
show voice hunt-group 1
Group 1
type: parallel
pilot number: 1000, peer-tag 2147483647
secondary number: 2000, peer-tag 2147483646
pilot name: SALES
secondary name: SALES-SECONDARY
list of numbers:
  Member Used-by State Login/Logout
  =====
  2004 2004 up login
  2005 2005 down -
preference: 0
preference (sec): 0
timeout: 180
final_number:
stat collect: no
phone-display: no
```

Example for Specifying a Description for a Voice Hunt-Group

The following example shows how to specify a description for voice hunt-group 12 using the **description** command and presents the description in the output of the **do show run** command:

```
Router(config)# voice hunt-group 12 parallel
Router (config-voice-hunt-group)# description ?
  LINE description for this hunt group
Router (config-voice-hunt-group)# description specific huntgroup description
```

```
Router (config-voice-hunt-group)# do show run | sec voice hunt-group
voice hunt-group 12 parallel
  timeout 0
description specific huntgroup description
```

Example for Logout Display

In the following example, the description is set to “Marketing Hunt Group.” This information will be shown in the configuration output and also on the display of IP phones that are receiving calls from this hunt group. The display-logout message is set to “Night Service,” which will be displayed on IP phones that are members of the hunt group when all the members are logged out.

```
ephone-hunt 17 sequential

pilot 3000

list 3011, 3021, 3031

timeout 10

final 7600
```

```
description Marketing Hunt Group
display-logout Night Service
```

Example for Displaying Total Logged-In Time and Total Logged-Out Time for Each Hunt-Group Agent

The following example displays the duration (in sec) since a specific agent logged into and logged out of ephone hunt group 1 from 4:00 a.m. to 5:00 a.m. (0400 to 0500):

```
show ephone-hunt 1 statistics
Wed 04:00 - 05:00
Max Agents: 3
Min Agents: 3
Total Calls: 9
Answered Calls: 7
Abandoned Calls: 2
Average Time to Answer (secs): 6
Longest Time to Answer (secs): 13
Average Time in Call (secs): 75
Longest Time in Call (secs): 161
Average Time before Abandon (secs): 8
Calls on Hold: 2
Average Time in Hold (secs): 16
Longest Time in Hold (secs): 21
Per agent statistics:
Agent: 5012
  From Direct Call:
    Total Calls Answered: 3
    Average Time in Call (secs): 70
    Longest Time in Call (secs): 150
    Totals Calls on Hold: 1
    Average Hold Time (secs): 21
    Longest Hold Time (secs): 21
  From Queue:
    Total Calls Answered: 3
    Average Time in Call (secs): 55
    Longest Time in Call (secs): 78
    Total Calls on Hold: 2
    Average Hold Time (secs): 19
    Hold Time (secs): 26
Total logged in Time (secs) : 3000
Total logged out Time (secs) : 600

Agent: 5013
  From Direct Call:
    Calls Answered: 3
    Average Time in Call (secs): 51
    Longest Time in Call (secs): 118
    Totals Calls on Hold: 1
    Average Hold Time (secs): 11
    Longest Hold Time (secs): 11
  From Queue:
    Total Calls Answered: 1
    Average Time in Call (secs): 4
    Longest Time in Call (secs): 4
Total logged in Time (secs) : 3000
Total logged out Time (secs) : 600

Agent: 5014
  From Direct Call:
```

```

Total Calls Answered: 1
Average Time in Call (secs): 161
Longest Time in Call (secs): 161
From Queue:
Total Calls Answered: 1
Time in Call (secs): 658
Longest Time in Call (secs): 658
Total logged in Time (secs) : 3000
Total logged out Time (secs) : 600

```

```

Queue related statistics:
Total calls presented to the queue: 5
Calls handoff to IOS: 5
Number of calls in the queue: 0
Average time to handoff (secs): 2
Longest time to handoff (secs): 3
Number of abandoned calls: 0
Average time before abandon (secs): 0
Calls forwarded to voice mail: 0
Calls answered by voice mail: 0
Number of error calls: 0

```



Note The per agent statistics are displayed for both static and dynamic agents.

Example for Dynamic Membership To Ephone-Hunt

The following example creates four ephone-dns and a hunt group that includes the first ephone-dn and two wildcard slots. The last three ephone-dns are enabled for group hunt dynamic membership. Each of them can join and leave the hunt group whenever one of the wildcard slots is available. Standard FACs have been enabled, and the agents use standard FACs to join (*3) and leave (#3) the hunt group. You can also use the **fac** command to create custom FACs for these actions if you prefer.

```

ephone-dn 22
  number 4566

ephone-dn 24
  number 4568
  ephone-hunt login

ephone-dn 25
  number 4569
  ephone-hunt login

ephone-dn 26
  number 4570
  ephone-hunt login

ephone-hunt 1 peer
  list 4566,*,*

```



```

timeout 10
final 7777

telephony-service
fac standard

```

Example for Dynamic Membership To Voice Hunt-Group

The following example creates one voice register dn and one voice hunt group which includes two wildcard slots. The voice register dn is enabled for group hunt dynamic membership. The DN can join and unjoin the hunt group whenever one of the wildcard slots is available. Standard FACs have been enabled, and the agents use standard FACs to join (*3) and unjoin (#3) the hunt group. You can also use the **fac** command to create custom FACs for these actions if you prefer.

```

Voice register dn 1
Number 1001
Voice-hunt-groups login

Voice hunt-group 1 parallel
Pilot number 100
List 1001, 1002, 1003, *, *

```

The following example creates three lines (3 voice register dns and 1 ephone dn) in phones with mixed shared line DN. Using the three wildcard entries configured, the DNs can join and unjoin the hunt groups. Here, standard FACs have been enabled, and the agents use standard FACs to join (*3) and unjoin (#4) the hunt group.

```

ephone-dn 1 dual-line
number 1001
shared-line sip
ephone 1
device-security-mode none
mac-address 1111.4444.3301
type 7970
button 1:1

voice register dn 1
voice-hunt-groups login
number 1001
name phone-1
shared-line max-calls 4

voice register dn 2
voice-hunt-groups login
number 2001
name phone-2
shared-line max-calls 4

voice register dn 3
voice-hunt-groups login
number 2002
name phone-3
shared-line max-calls 4

voice register pool 1
busy-trigger-per-button 2
id mac 00DA.5527.1BB7
type 8841
number 1 dn 1

```

Example for Agent Status Control using SCCP Phones

```

number 2 dn 2
number 3 dn 3
dtmf-relay rtp-nte
username cisco1 password cisco
codec g711ulaw
no vad

voice register pool 2
busy-trigger-per-button 2
id mac 00DA.5527.1BB7
type 8841
number 1 dn 1
number 2 dn 2
number 3 dn 3
dtmf-relay rtp-nte
username cisco1 password cisco
codec g711ulaw
no vad

```

Example for Agent Status Control using SCCP Phones

The following example sets up a peer ephone hunt group. It also establishes the appearance and order of soft keys for phones that are configured with ephone-template 7. These phones will have the HLog key available when they are idle, when they have seized a line, or when they are connected to a call. Phones without softkeys can use the standard HLog codes to toggle ready and not-ready status.

```

ephone-hunt 10 peer
pilot 450
list 451, 452, 453, 477
final 500
timeout 45
telephony-service
hunt-group logout HLog
fac standard
ephone-template 7
softkeys connected Endcall Hold Transfer HLog
softkeys idle Newcall Redial Pickup Cfdall HLog
softkeys seized Endcall Redial Pickup Cfdall HLog

```

Example for Agent Status Control using SIP Phones

The following example sets up a peer voice hunt group. It also establishes the appearance and order of soft keys for phones that are configured with voice register template 7. These phones will have the HLog key available when idle, when there is a ringIn, or when connected to a call. Phones without softkeys can use the standard HLog codes to toggle ready and not-ready status.

```

voice hunt-group 10 peer
pilot 450
list 451, 452, 453, 477
final 500
timeout 45

telephony-service
hunt-group logout HLog

```

```

fac standard

voice register template 7
  softkeys connected Endcall Hold Transfer HLog
  softkeys idle Newcall Redial Pickup Cfwdall HLog
  softkeys ringIn Answer DND iDivert HLog

```

Example for Automatic Agent Not-Ready for Ephone Hunt Group

The following example enables automatic status change to not-ready after one unanswered hunt group call (the default) for both dynamic and static hunt group members (the default). It also specifies that the phones which are automatically put into the not-ready status should only be blocked from further hunt-group calls and that they should be able to receive calls that directly dial their extensions.

```

ephone-hunt 3 peer
  pilot 4200
  list 1001, 1002, 1003
  timeout 10
  auto logout
  final 4500
telephony-service
  hunt-group logout HLog

```

The following example enables automatic status change to not-ready after two unanswered hunt group calls for any ephone-dn that dynamically logs in to the hunt group using the wildcard slot in the hunt group list. Phones that are automatically placed in the not-ready status when they do not answer two hunt-group calls are also placed into DND status (they will also not accept directly dialed calls).

```

ephone-hunt 3 peer
  pilot 4200
  list 1001, 1002, *
  timeout 10
  auto logout 2 dynamic
  final 4500
telephony-service
  hunt-group logout DND

```

Example for Automatic Agent Not-Ready for Voice Hunt Group

In the following example, voice hunt-group 1 is configured to permit automatic logout. If hunt group calls that are presented to 1001, 1002, 1003, and 1004 are unanswered (that is, if they ring longer than 40 seconds each), voice register pool 1, voice register pool 2, ephone 1, and ephone 2 are automatically logged out. All unanswered calls are sent to DN 5000.

```

Router(config)# voice register dn 1
Router(config-register-dn)# number 1001
Router(config)# voice register dn 2
Router(config-register-dn)# number 1002

Router(config)# ephone-dn 1
Router(config-ephone-dn)# number 1003
Router(config)# ephone-dn 2

```

Example for Call Statistics From a Voice Hunt Group

```

Router(config-ephone-dn) # number 1004

Router(config)# voice register pool 1
Router(config-register-pool)# number 1 dn 1

Router(config)# voice reister pool 2
Router(config-register-pool)# number 1 dn 2

Router(config)# ephone 1
Router(config-ephone)# button 1:1

Router(config)# ephone 2
Router(config-ephone)# button 1:2

Router(config)# voice hunt-group 1 peer
Router(config-voice-hunt)# pilot 1111
Router(config-voice-hunt)# list 1001, 1002, 1003, 1004
Router(config-voice-hunt)# final 5000
Router(config-voice-hunt)# timeout 40
Router(config-voice-hunt)# auto logout 4

```

Example for Call Statistics From a Voice Hunt Group

The following is a sample output from the **show voice hunt-group statistics** command. The output includes direct calls to a voice hunt group number and calls from queue/B-ACD.

```

Router# show voice hunt-group 1 statistics last 1 h
Wed 04:00 - 05:00
Max Agents: 3
Min Agents: 3
Total Calls: 9
Answered Calls: 7
Abandoned Calls: 2
Average Time to Answer (secs): 6
Longest Time to Answer (secs): 13
Average Time in Call (secs): 75
Longest Time in Call (secs): 161
Average Time before Abandon (secs): 8
Calls on Hold: 2
Average Time in Hold (secs): 16
Longest Time in Hold (secs): 21
Per agent statistics:
Agent: 5012
  From Direct Call:
    Total Calls Answered: 3
    Average Time in Call (secs): 70
    Longest Time in Call (secs): 150
    Totals Calls on Hold: 1
    Average Hold Time (secs): 21
    Longest Hold Time (secs): 21
  From Queue:
    Total Calls Answered: 3
    Average Time in Call (secs): 55
    Longest Time in Call (secs): 78
    Total Calls on Hold: 2
    Average Hold Time (secs): 19
    Longest Hold Time (secs): 26
    Total Loged in Time (secs): 3000
    Total Loged out Time (secs): 600
Agent: 5013
  From Direct Call:

```

```

Total Calls Answered: 3
Average Time in Call (secs): 51
Longest Time in Call (secs): 118
Totals Calls on Hold: 1
Average Hold Time (secs): 11
Longest Hold Time (secs): 11
From Queue:
Total Calls Answered: 1
Average Time in Call (secs): 4
Longest Time in Call (secs): 4
Total Logged in Time (secs): 3000
Total Logged out Time (secs): 600
Agent: 5014
From Direct Call:
Total Calls Answered: 1
Average Time in Call (secs): 161
Longest Time in Call (secs): 161
From Queue:
Total Calls Answered: 1
Average Time in Call (secs): 658
Longest Time in Call (secs): 658
Total Logged in Time (secs): 3000
Total Logged out Time (secs): 600

Queue related statistics:
Total calls presented to the queue: 5
Calls handoff to IOS: 5
Number of calls in the queue: 0
Average time to handoff (secs): 2
Longest time to handoff (secs): 3
Number of abandoned calls: 0
Average time before abandon (secs): 0
Calls forwarded to voice mail: 0
Calls answered by voice mail: 0
Number of error calls: 0

```



Note The per agent statistics are displayed for both static and dynamic agents.

Example for Night Service on SCCP Phones

The following example provides night service before 8 a.m. and after 5 p.m. Monday through Friday, before 8 a.m. and after 1 p.m. on Saturday, and all day Sunday. Extension 1000 is designated as a night-service extension. Incoming calls to extension 1000 during the night-service period ring on extension 1000 and provide night-service notification to phones that are designated as night-service phones. In this example, the night-service phones are ephone 14 and ephone 15. The night-service notification consists of a single ring on the phone and a display of “Night Service 1000.” A night-service toggle code has been configured, *6483 (*NITE), by which a phone user can activate or deactivate night-service conditions during the hours of night service.

```

telephony-service
night-service day mon 17:00 08:00
night-service day tue 17:00 08:00
night-service day wed 17:00 08:00
night-service day thu 17:00 08:00
night-service day fri 17:00 08:00

```

```

night-service day sat 13:00 12:00
night-service day sun 12:00 08:00
night-service code *6483
!
ephone-dn 1
  number 1000
  night-service bell
!
ephone-dn 2
  number 1001
  night-service bell
!
ephone-dn 10
  number 2222
!
ephone-dn 11
  number 3333
!
ephone 5
  mac-address 1111.2222.0001
  button 1:1 2:2
!
ephone 14
  mac-address 1111.2222.0002
  button 1:10
  night-service bell
!
ephone 15
  mac-address 1111.2222.0003
  button 1:11
  night-service bell

```

Example for Night Service on SIP Phones

The following example provides night service everyday before 10:00 am and after 7:00 pm. Incoming calls to extension 3000 during the night-service period ring on extension 3000 and provide night-service notification to phones that are designated as night-service phones. In this example, the night-service phones are pool 2 and pool 3. The night-service notification consists of a single ring on the phone and a display of “Night Service 3000.” A night-service toggle code has been configured, *8765 (*NITE), by which a phone user can activate or deactivate night-service conditions during the hours of night service.

```

telephony-service
night-service everyday 19:00 10:00

```

```
night-service code *8765
service directed-pickup gpickup
call-park system application

voice register dn 1
number 3000
night-service bell

voice register dn 2
number 3001
night-service bell

voice register dn 10
number 5555

voice register dn 11
number 6666

voice register pool 1
mac-address 1111.2222.0001
number 1 dn 1
number 2 dn 2

voice register pool 2
mac-address 1111.2222.0002
number 1 dn 10
night-service bell

voice register pool 3
mac-address 1111.2222.0003
number 1 dn 11
night-service bell
```

Examples for Overlaid Ephone-dns

Example for Overlaid Ephone-dn

The following example creates three lines (ephone-dns) that are shared across three IP phones to handle three simultaneous calls to the same telephone number. Three instances of a shared line with the extension number 1001 are overlaid onto a single button on each of three phones. A typical call flow is as follows. The first call goes to ephone 1 (highest preference) and rings button 1 on all three phones (huntstop is off). The call is answered on ephone 1. A second call to extension 1001 hunts onto ephone-dn 2 and rings on the two remaining ephones, 11 and 12. The second call is answered by ephone 12. A third simultaneous call to extension 1001 hunts onto ephone-dn 3 and rings on ephone 11, where it is answered. Note that the no huntstop command is used to allow hunting for the first two ephone-dns, and the huntstop command is used on the final ephone-dn to stop call-hunting behavior. The preference command is used to create different selection preferences for each ephone-dn.

```
ephone-dn 1
number 1001
no huntstop
preference 0

ephone-dn 2
number 1001
no huntstop
```

Example for Overlaid Dual-Line Ephone-dn

```

    preference 1

ephone-dn 3
  number 1001
  huntstop
  preference 2

ephone 10
  button 101,2,3
  ephone 11
  button 101,2,3

ephone 12
  button 101,2,3

```

Example for Overlaid Dual-Line Ephone-dn

The following example shows how to overlay dual-line ephone-dns. In addition to using the **huntstop** and **preference** commands, you must use the **huntstop channel** command to prevent calls from hunting to the second channel of an ephone-dn. This example overlays five ephone-dns on button 1 on five different ephones. This allows five separate calls to the same number to be connected simultaneously, while occupying only one button on each phone.

```

ephone-dn 10 dual-line
  number 1001
  no huntstop
  huntstop channel
  preference 0

ephone-dn 11 dual-line
  number 1001
  no huntstop
  huntstop channel
  preference 1

ephone-dn 12 dual-line
  number 1001
  no huntstop
  huntstop channel
  preference 2

ephone-dn 13 dual-line
  number 1001
  preference 3
  no huntstop
  huntstop channel

ephone-dn 14 dual-line

```



```
number 1001
preference 4
huntstop
huntstop channel

ephone 33
mac 00e4.5377.2a33
button 1o10,11,12,13,14

ephone 34
mac 9c33.0033.4d34
button 1o10,11,12,13,14

ephone 35
mac 1100.8c11.3865
button 1o10,11,12,13,14

ephone 36
mac 0111.9c87.3586
button 1o10,11,12,13,14

ephone 37
mac 01a4.8222.3911
button 1o10,11,12,13,14
```

Example for Shared-line Overlaid Ephone-dns

The following is an example of a unique ephone-dn as the primary dn in a simple shared-line overlay configuration. The **no huntstop** command is configured for all the ephone-dns except ephone-dn 12, the last one in the overlay set. Because the ephone-dns are dual-line dns, the **huntstop-channel** command is also configured to ensure that the second channel remains free for outgoing calls and for conferencing.

```
ephone-dn 1 dual-line
number 101
huntstop-channel
!
ephone-dn 2 dual-line
number 102
huntstop-channel
!
ephone-dn 10 dual-line
number 201
no huntstop
```

Example for Overlaid Ephone-dn with Call Waiting

```

    huntstop-channel
!
ephone-dn 11 dual-line
    number 201
    no huntstop
    huntstop-channel
!
ephone-dn 12 dual-line
    number 201
    huntstop-channel
!
!The following ephone configuration includes (unique) ephone-dn 1 as the primary line in a
    shared-line overlay
ephone 1
    mac-address 1111.1111.1111
    button 1o1,10,11,12
!
!The next ephone configuration includes (unique) ephone-dn 2 as the primary line in another
    shared-line overlay
!
ephone 2
    mac-address 2222.2222.2222
    button 1o2,10,11,12

```

Example for Overlaid Ephone-dn with Call Waiting

In following example, button 1 on ephone 1 though ephone 3 uses the same set of overlaid ephone-dns with call waiting that share the number 1111. The button also accept calls to each ephone's unique (nonshared) ephone-dn number. Note that if ephone-dn 10 and ephone-dn 11 are busy, the call will go to ephone-dn 12. If ephone-dn 12 is busy, the call will go to voice mail.

```

ephone-dn 1 dual-line
    number 1001

ephone-dn 2 dual-line
    number 1001

ephone-dn 3 dual-line
    number 1001

ephone-dn 10 dual-line
    number 1111
    no huntstop
    huntstop channel

```

```
call-forward noan 7000 timeout 30
```

```
ephone-dn 11 dual-line
number 1111
preference 1
no huntstop
huntstop channel
call-forward noan 7000 timeout 30
```

```
ephone-dn 12 dual-line
number 1111
preference 2
huntstop channel
call-forward noan 7000 timeout 30
call-forward busy 7000
```

```
ephone 1
button 1c1,10,11,12
```

```
ephone 2
button 1c2,10,11,12
```

```
ephone 3
button 1c3,10,11,12
```

Example for Overlaid Ephone-dns with Rollover Buttons

The following example configures a “3x3” shared-line setup for three ephones and nine shared lines (ephone-dns 20 to 28). Each ephone has a unique ephone-dn for each of its three buttons (ephone-dns 11 to 13 on ephone 1, ephone-dns 14 to 16 on ephone 2, and ephone-dns 17 to 19 on ephone 3). The rest of the ephone-dns are shared among the three phones. Three phones with three buttons each can take nine calls. The overflow buttons provide the ability for an incoming call to ring on the first available button on each phone.

```
ephone-dn 11
number 2011
```

```
ephone-dn 12
number 2012
```

```
ephone-dn 13
number 2013
```

```
ephone-dn 14
```

Example for Called-Name Display for Voice Hunt Group

```

number 2014
.
.
.
ephone-dn 28
number 2028

ephone 1
button 1011,12,13,20,21,22,23,24,25,26,27,28 2x1 3x1

ephone 2
button 1014,15,16,20,21,22,23,24,25,26,27,28 2x1 3x1

ephone 3
button 1017,18,19,20,21,22,23,24,25,26,27,28 2x1 3x1

```

Example for Called-Name Display for Voice Hunt Group

The Called-Name Display feature supports the display of the name associated with a called number for incoming calls to IP phones configured on Unified CME. For an example of Called-Name Display for Voice Hunt Group calls, see [Example for Called-Name Display for Voice Hunt Group](#).

Example for Called Directory Name Display for Overlaid Ephone-dns

The following example demonstrates the display of a directory name for a called ephone-dn that is part of an overlaid ephone-dn set. For configuration information, see [Directory Services](#).

This configuration of overlaid ephone-dns uses wildcards in the secondary numbers for the ephone-dns. Wildcards allow you to control the display according to the number that was dialed. The example is for a medical answering service with three IP phones that accept calls for nine doctors on one button. When a call to 5550101 rings on button 1 on phone 1 to phone 3, “doctor1” is displayed on all three phones.

```

telephony-service
service dnis dir-lookup
directory entry 1 5550101 name doctor1
directory entry 2 5550102 name doctor2
directory entry 3 5550103 name doctor3
directory entry 4 5550110 name doctor4
directory entry 5 5550111 name doctor5
directory entry 6 5550112 name doctor6
directory entry 7 5550120 name doctor7
directory entry 8 5550121 name doctor8
directory entry 9 5550122 name doctor9
ephone-dn 1
number 5500 secondary 555000.
ephone-dn 2

```

```

number 5501 secondary 555001.
ephone-dn 3
number 5502 secondary 555002.
ephone 1
button 1o1,2,3
mac-address 1111.1111.1111
ephone 2
button 1o1,2,3
mac-address 2222.2222.2222
ephone 3
button 1o1,2,3
mac-address 3333.3333.3333

```

The following example shows a hunt-group configuration for a medical answering service with two phones and four doctors. Each phone has two buttons, and each button is assigned two doctors' numbers. When a patient calls 5550341, Cisco Unified CME matches the hunt-group pilot secondary number (555....), rings button 1 on one of the two phones, and displays "doctor1." For more information about hunt-group behavior, see [Hunt Groups, on page 9](#). Note that wildcards are used only in secondary numbers and cannot be used with primary numbers.

```

telephony-service
service dnis dir-lookup
max-redirect 20
directory entry 1 5550341 name doctor1
directory entry 2 5550772 name doctor1
directory entry 3 5550263 name doctor3
directory entry 4 5550150 name doctor4
ephone-dn 1
number 1001
ephone-dn 2
number 1002
ephone-dn 3
number 1003
ephone-dn 4
number 104
ephone 1
button 1o1,2
button 2o3,4
mac-address 1111.1111.1111
ephone 2
button 1o1,2
button 2o3,4
mac-address 2222.2222.2222

```

Example for Called Ephone-dn Name Display for Overlaid Ephone-dns

```

ephone-hunt 1 peer
  pilot 5100 secondary 555....
  list 1001, 1002, 1003, 1004
  final number 5556000
  hops 5
  preference 1
  timeout 20
  no-reg

```

Example for Called Ephone-dn Name Display for Overlaid Ephone-dns

The following example demonstrates the display of the name assigned to the called ephone-dn using the **name** command. For information about configuring this feature, see [Directory Services](#).

In this example, three phones have button 1 assigned to pick up three shared 800 numbers for three different catalogs.

The default display for the phones is the number of the first ephone-dn listed in the overlay set (18005550100). A call is made to the first ephone-dn (18005550100), and the caller ID (for example, 4085550123) is visible on all phones. The user for phone 1 answers the call. The caller ID (4085550123) remains visible on phone 1, and the displays on phone 2 and phone 3 return to the default display (18005550100). A call to the second ephone-dn (18005550101) is made. The default display on phone 2 and phone 3 is replaced with the called ephone-dn's name (catalog1) and number (18005550101).

```

telephony-service
  service dnis overlay
ephone-dn 1
  number 18005550100
ephone-dn 2
  name catalog1
  number 18005550101
ephone-dn 3
  name catalog2
  number 18005550102
ephone-dn 4
  name catalog3
  number 18005550103
ephone 1
  button 1,2,3,4
ephone 2
  button 1,2,3,4
ephone 3
  button 1,2,3,4

```

Example for OOD-R

```
voice register global
mode cme
source-address 11.1.1.2 port 5060
load 7971 SIP70.8-0-1-11S
load 7970 SIP70.8-0-1-11S
load 7961GE SIP41.8-0-1-0DEV
load 7961 SIP41.8-0-1-0DEV
authenticate ood-refer
authenticate credential 1 tftp://172.18.207.15/labtest/cred1.csv
create profile sync 0004550081249644
...
sip-ua
authentication username
```

Where to Go Next

Dial-Peer Call Hunt and Hunt Groups

Dial peers other than ephone-dn dial peers can be directly configured as hunt groups or rotary groups, in which multiple dial peers can match incoming calls. (These are not the same as Cisco Unified CME ephone hunt groups.) For more information, see the “Hunt Groups” section of the [Dial Peers Features and Configuration](#) chapter of [Dial Peer Configuration on Voice Gateway Routers](#).

Called-Name Display

This feature allows you to specify that the name of the called party, rather than the number, should be displayed for incoming calls. This feature is very helpful for agents answering calls for multiple ephone-dns that appear on a single line button in an ephone-dn overlay set. For more information, see [Directory Services](#).

Soft Key Control

If the **hunt-group logout** command is used with the **HLog** keyword, the HLog soft key appears on phones during the idle, connected, and seized call states. The HLog soft key is used to toggle an agent from the ready to not-ready status or from the not-ready to ready status. To move or remove the HLog soft key on one or more phones, create and apply an ephone template that contains the appropriate **softkeys** commands.

From Unified CME Release 11.6 onwards, HLog keyword is supported with the **hunt-group logout** command configured under telephony service. On SIP phone, HLog softkey appears on phone for idle, ringIn, and connected state.

For more information, see [Customize Softkeys](#).

Feature Access Codes (FACs)

Dynamic membership allows agents at authorized ephones to join or leave a hunt group using a feature access code (FAC) after standard or custom FACs are enabled.

In Cisco Unified CME 4.0 and later versions, you can activate call pickup using a feature access code (FAC) instead of a soft key when standard or custom FACs have been enabled for your system. The following are the standard FACs for call pickup:

- Pickup group—Dial the FAC and a pickup group number to pick up a ringing call in a different pickup group than yours. Standard FAC is **4.
- Pickup local—Dial the FAC to pick up a ringing call in your pickup group. Standard FAC is **3.

- Pickup direct—Dial the FAC and the extension number to pick up a ringing call at any extension. Standard FAC is **5.

For more information about FACs, see [Feature Access Codes](#).

Controlling Use of the Pickup Soft Keys

To block the functioning of the group pickup (GPickUp) or local pickup (Pickup) soft key without removing the key display, create and apply an ephone template that contains the **features blocked** command. For more information, see [Configure Call Blocking](#).

To remove the group pickup (GPickUp) or local pickup (Pickup) soft key from one or more phones, create and apply an ephone template that contains the appropriate **softkeys** command. For more information, see [Customize Softkeys](#).

Ephone-dn Templates

The **ephone-hunt login** command authorizes an ephone-dn to dynamically join and leave an ephone hunt group. It can be included in an ephone-dn template that is applied to one or more individual ephone-dns. For more information, see [Templates](#).

Ephone Hunt Group Statistics Reports

Several different types of statistics can help you track whether your current ephone hunt groups are meeting your call coverage needs. These statistics can be displayed on-screen or written to files.

For more information, see the [Cisco Unified CME Basic Automatic Call Distribution and Auto-Attendant Service](#) chapter in [Cisco Unified CME B-ACD and Tcl Call-Handling Applications](#).

Voice Hunt Group Statistics Reports

The **hunt-group statistics write-all** command writes all the ephone and voice hunt group statistics to a file.

The **hunt-group statistics write-v2** command writes all the ephone and voice hunt group statistics to a file, along with total logged in and logged out time for agents.

The **statistics collect** command enables the collection of call statistics for a voice hunt group.

The **show telephony-service all** command displays the total number of ephone and voice hunt groups that have statistics collection turned on.

The **show voice hunt-group statistics** command displays call statistics from voice hunt groups.

For more information, see [Cisco Unified Communications Manager Express Command Reference](#).

Do Not Disturb

The Do Not Disturb (DND) feature can be used as an alternative to the HLog function for preventing incoming calls from ringing on a phone. The difference is that HLog prevents only hunt group calls from ringing, while DND prevents all calls from ringing. For more information, see [Do Not Disturb](#).

Automatic Call Forwarding During Night-Service

To have an ephone-dn forward all its calls automatically during night-service hours, use the **call-forward night-service** command. For more information, see [Enable Call Forwarding for a Directory Number](#).

Ephone Templates

The **night-service bell** command specifies that a phone will receive night-service notification when calls are received at ephone-dns configured as night-service ephone-dns. This command can be included in an ephone template that is applied to one or more individual ephones.

For more information, see [Templates](#).

Feature Information for Call Coverage Features

The following table provides release information about the feature or features described in this module. This table lists only the software release that introduced support for a given feature in a given software release train. Unless noted otherwise, subsequent releases of that software release train also support that feature.

Use Cisco Feature Navigator to find information about platform support and Cisco software image support. To access Cisco Feature Navigator, go to www.cisco.com/go/cfn. An account on Cisco.com is not required.

Table 5: Feature Information for Call Coverage

Feature Name	Cisco Unified CME version	Modification
Call Hunt	3.4	Added support for configuring call hunt features on SIP IP phones connected directly to Cisco Unified CME.
	3.0	<ul style="list-style-type: none"> • Preference for secondary numbers was introduced. • Huntstop was introduced.
	1.0	<ul style="list-style-type: none"> • Ephone-dn dial-peer preference was introduced. • Huntstop was introduced.
Call Pickup	7.1	Added Call Pickup support for SIP phones.
	4.0	<ul style="list-style-type: none"> • The ability to globally disable directed call pickup was introduced. • Feature access codes for call pickup were introduced. • The ability to block call pickup on individual phones was introduced.
	3.2	The ability to remove or rearrange soft keys on individual phones was introduced.
	3.0	Call pickup groups were introduced.

Feature Name	Cisco Unified CME version	Modification
Call Waiting	8.0	Added Cancel Call Waiting feature.
	3.4	Added support for configuring call waiting for SIP phones directly connected to Cisco Unified CME.
Callback Busy Subscriber	3.0	Callback busy subscriber was introduced.
Hunt Groups	12.2	Introduced support for Shared Lines and Mixed Shared Lines (SIP and SCCP phones) on Parallel, Sequential, Peer, and Longest Idle Voice Hunt Groups.
	7.0/4.3	Added support for the following: <ul style="list-style-type: none"> • SCCP phones in Voice Hunt-Groups • Call Forwarding to a Parallel Voice Hunt-Group (Blast Hunt Group) • Call Transfer to a Voice Hunt-Group • Member of Voice Hunt-Group can be a SCCP phone, FXS analog phone, DS0-group, PRI-group, SIP phone, or SIP trunk

Feature Name	Cisco Unified CME version	Modification
Hunt Groups	4.0	

Feature Name	Cisco Unified CME version	Modification
		<p>Added support for the following on IP phones running SCCP:</p> <ul style="list-style-type: none"> • Maximum number of hunt groups in a system was increased from 20 to 100 and maximum number of agents in a hunt group was increased from 10 to 20. • Maximum number of hops automatically adjusts to the number of agents. • A description can be added to phone displays and configuration output to provide hunt group information associated with ringing and answered calls. • A configurable message can be displayed on agent phones when all agents are in the not-ready status to advise the destination to which calls are being forwarded or other useful information. • No-answer timeouts can be set individually for each ephone-dn in the list and a cumulative no-answer timeout can be set for all ephone-dns. • Automatic logout trigger criterion was changed from exceeding the specified timeout to exceeding the specified number of calls. The name of this feature was changed from automatic logout to automatic agent status not-ready. • Dynamic hunt group membership is introduced. Agents can join and leave hunt groups whenever a wildcard slot is available. • Agent status control using an HLog soft key or feature

Feature Name	Cisco Unified CME version	Modification
		<p>access code (FAC) is introduced. Agents can put their lines into not-ready state to temporarily block hunt group calls without relinquishing their slots in group.</p> <ul style="list-style-type: none"> • Calls can be blocked from agent phones that are not idle or on hook. • Calls that are not answered by the hunt group can be returned to the party who transferred them into the huntgroup. • Calls parked by hunt group agents can be returned to a different entry point. • (Sequential hunt groups only) Local calls to a hunt group can be restricted so that they will not be forwarded past the initial agent that is rung. • (Longest-idle hunt groups only) A new command, the from-ring command, specifies that on-hook time stamps should be updated when a call rings an agent and when a call is answered by an agent.
	3.4	Added support for configuring hunt groups for SIP phones directly connected to Cisco Unified CME.
	3.2.1	<ul style="list-style-type: none"> • Maximum number of hunt groups in a system was increased to 20. • Automatic logout capability was introduced.
	3.2	Longest-idle hunt groups were introduced.
	3.1	Secondary pilot numbers were introduced.

Feature Name	Cisco Unified CME version	Modification
	3.0	Peer and sequential ephone hunt groups were introduced.
Night Service	11.6	Night service support for mixed deployment of SIP and SCCP phone was introduced.
	11.5	Night service support for SIP phone was introduced.
	4.0	The night-service everyday , night-service weekday , and night-service weekend commands were introduced.
	3.3	The behavior of the night-service code was changed. Previously, using the night-service code at a phone either enabled or disabled night service for the ephone-dns on that phone. Now, using the night-service code at a phone enables or disables night service for all night-service ephone-dns.
	3.0	Night service was introduced.

Feature Name	Cisco Unified CME version	Modification
Overlaid Ephone-dns	4.0	<ul style="list-style-type: none"> The number of ephone-dns that can be overlaid on a single button using the button command and the o or c keyword was increased from 10 to 25. The ability to extend calls for overlaid ephone-dns to other buttons (rollover buttons) on the same phone was introduced. Rollover buttons are created by using the x keyword with the button command. The number of waiting calls that can be displayed for overlaid ephone-dns that have call waiting configured has been increased to six for the following phone types: Cisco Unified IP Phone 7940G, 7941G, 7941G-GE, 7960G, 7961G, 7961G-GE, 7970G, and 7971G-GE.
	3.2.1	Call waiting for overlaid ephone-dns was introduced and the c keyword was added to the button command.
	3.0	Overlaid ephone-dns were introduced and the o keyword was added to the button command.
All Agents Logged Out Message for VHG Phones	12.2	Introduced support for all agents logged out display message for Cisco IP Phone 8800 Series on Cisco 4000 Series Integrated Services Routers.
Agent Status Control	12.2	Agent Status Control enhancements was supported.

Feature Name	Cisco Unified CME version	Modification
Voice Hunt Group Enhancements	11.6	Hlog Softkey support for SIP Phones was introduced.
	9.0	Allows all ephone and voice hunt group call statistics to be written to a file using the hunt-group statistics write-all command.
Preventing Local-Call Forwarding to Final Agent in Voice Hunt Groups	9.5	The no forward local-calls command was introduced in ephone-hunt group to prevent a local call from being forwarded to the next agent.
Enhancement of Support for Hunt Group	9.5	Hunt group agent statistics of Cisco Unified SCCP IP phones is enhanced to include Total logged in time and Total logged out.
Total Logged in and Logged out Time Statistics for agent	9.5	Allows all ephone hunt call statistics to be written to a file along with total logged in and logged out time for agents using the hunt-group statistics write-v2 command.
Enhancement of Support for Total Logged in and Logged out Time Statistics for Agent	11.5	Allows all voice hunt call statistics to be written to a file along with total logged in and logged out time for agents using the hunt-group statistics write-v2 command.
Out-of-Dialog Refer	4.1	Out-of Dialog REFER support was added.