



Installing the WAVE-594 and WAVE-694

This chapter describes how to install a WAVE-594 and WAVE-694 in an equipment rack.

This chapter contains the following sections:

- [Rack-Mounting Considerations, Parts, and Tools](#)
- [Rack Mounting and Cabling the WAVE-594 and WAVE-694](#)
- [Connecting Power and Booting the System](#)
- [Checking the LEDs](#)
- [Removing or Replacing a WAVE Appliance](#)
- [Upgrading the WAVE-694 to a New Release](#)

Before you begin the installation, read [Chapter 2, “Preparing to Install the WAVE-594 and WAVE-694”](#) and the [Regulatory Compliance and Safety Information for Cisco Wide Area Virtualization Engines](#) document.



Warning

Read the installation instructions before connecting the system to the power source. Statement 1004.

Rack-Mounting Considerations, Parts, and Tools

To allow for servicing and adequate airflow, observe the following space and airflow requirements when deciding where to install a rack:

- Leave a minimum clearance of 63.5 cm (25 in) in front of the rack.
- Leave a minimum clearance of 76.2 cm (30 in) behind the rack.
- Leave a minimum clearance of 121.9 cm (48 in) from the back of the rack to the back of another rack or row of racks.

The WAVE-594 and WAVE-694 appliance draws in cool air through the front door and expels warm air through the rear door. Therefore, the front and rear rack doors must be adequately ventilated to allow ambient room air to enter the cabinet, and the rear door must be adequately ventilated to allow the warm air to escape from the cabinet.



Caution

To prevent improper cooling and damage to the equipment, do not block the ventilation openings.

When vertical space in the rack is not filled by a WAVE appliance or rack component, the gaps between the components cause changes in airflow through the rack and across the WAVE appliances. Cover all gaps with filler panels to maintain proper airflow.

**Caution**

Always use filler panels to fill empty vertical spaces in the rack. This arrangement ensures proper airflow. Using a rack without filler panels results in improper cooling that can lead to thermal damage.

- Observe the following additional requirements to ensure adequate airflow and to prevent damage to the equipment:
 - Front and rear doors—If the 42U rack includes closing front and rear doors, you must allow 5,350 sq cm (830 sq in) of holes evenly distributed from top to bottom to permit adequate airflow (equivalent to the required 64 percent open area for ventilation).
 - Side—The clearance between the installed rack component and the side panels of the rack must be a minimum of 7 cm (2.75 in).

**Note**

Rack-mounting the WAVE-594 and WAVE-694 appliance is supported for rear mount in a 4-post rack or front mount in a 2-post rack.

Table 3-1 lists the rack mounting hardware included in your shipping container. You will need a Phillips screwdriver. Verify that you have received the following items for the installation:

Table 3-1 Rack Mount Hardware Provided

Item	Name	Description	Qty	Rack Type	
				2-post	4-post
1	Front rack mount bracket	Front rack mount L bracket	2	X	X
2	Rear rack mount bracket holder	Rear rack mount bracket holder	2		X
3	32" rear rack mount bracket	Rear rack mount bracket (32 inch)	2		X
4	Front rack mount bracket screw	Front rack bracket screw, #6-32 x 0.30", Wafer Head, Phillips, Steel w/ Zinc and Black	6	X	X
5	Rear rack mount bracket holder screw	Rear bracket holder screw, M4 x0.7 x 4.85 mm, 120°, Flat Head, Phillips, Steel w/ Zinc and Black	6		X
6	Rack screw	Rack screw, #10-32 x 0.50", Truss Head, Phillips, Steel w/ Ni and Black	8	X	X
7	Rack screw	Rack screw, M5 x 12.7 mm, Truss Head, Phillips, Steel w/ Ni and Black	8		X

Rack Mounting and Cabling the WAVE-594 and WAVE-694

This section contains the following topics:

- [Mounting in a 4-Post Rack](#)
- [Front-Mounting in a 2-Post Rack](#)
- [Cabling](#)



Warning To prevent bodily injury when mounting or servicing this unit in a rack, you must take special precautions to ensure that the system remains stable. The following guidelines are provided to ensure your safety:

- This unit should be mounted at the bottom of the rack if it is the only unit in the rack.
 - When mounting this unit in a partially filled rack, load the rack from the bottom to the top with the heaviest component at the bottom of the rack.
 - If the rack is provided with stabilizing devices, install the stabilizers before mounting or servicing the unit in the rack. Statement 1006
-

Mounting in a 4-Post Rack

Follow these steps to mount the WAVE appliance in a 4-post rack:

-
- Step 1** Prepare for installation by reading the “[Rack-Mounting Considerations, Parts, and Tools](#)” section on [page 3-1](#)) and verify that you have the correct tools and rack-mount hardware necessary for the installation.
- Step 2** Attach the front rack mount brackets (item #1 in [Table 3-1](#)) using the six front bracket screws (item #4 in [Table 3-1](#)). (See [Figure 3-4](#).)
- Step 3** Attach the rear rack mount holder brackets (item #2 in [Table 3-1](#)) using the six rear bracket holder screws (item #5 in [Table 3-1](#)).



Note The front arrow must point toward the front of the chassis.

Figure 3-1 Attaching the Brackets

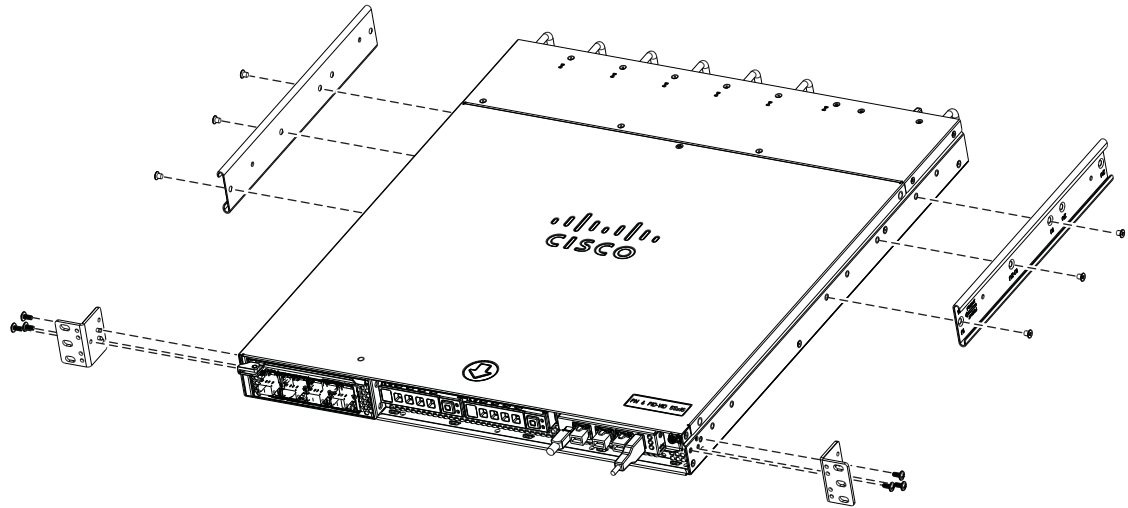

330144

- Step 4** Attach the rear mount bracket holders (item #3 in [Table 3-1](#)) to the rear rack posts using four appropriate rack screws (item #6 or #7 in [Table 3-1](#)). (see [Figure 3-2](#))

Figure 3-2 Attaching Rear Rack Mount to the Rack

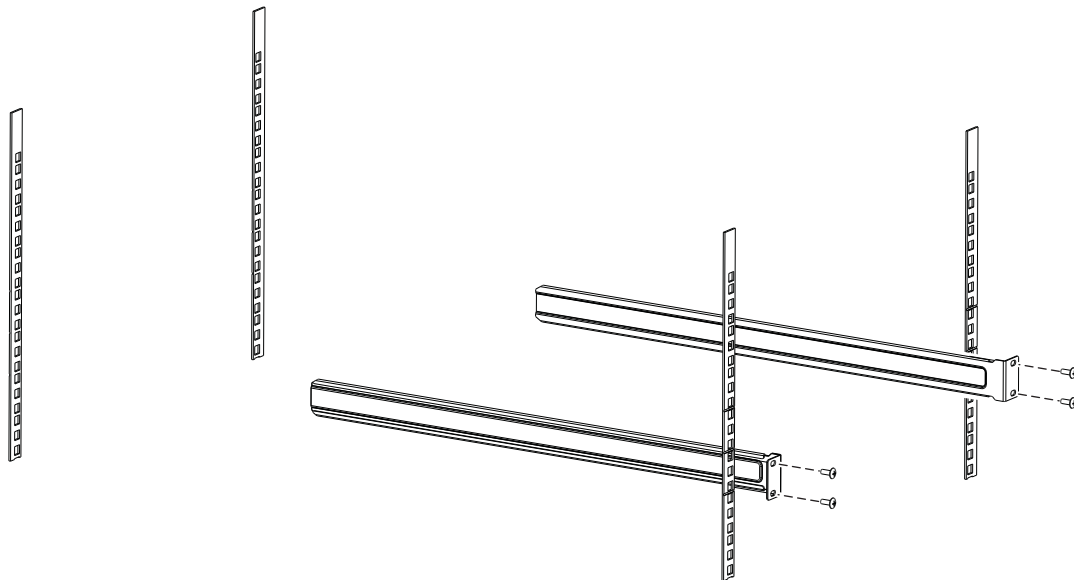

330142

- Step 5** Insert the chassis between the mounting posts and secure (see [Figure 3-3](#)):
- Insert the chassis into the rack with the rear rack mount holders sliding into the rear rack mount brackets.
 - Align the mounting holes in the front brackets with the mounting holes in the equipment rack.
 - Secure the chassis using four (two on each side) rack screws (item #6 or #7 in [Table 3-1](#)) through the holes in the front brackets and into the threaded holes in the mounting post.

Figure 3-3 Rack-Mounting the Chassis

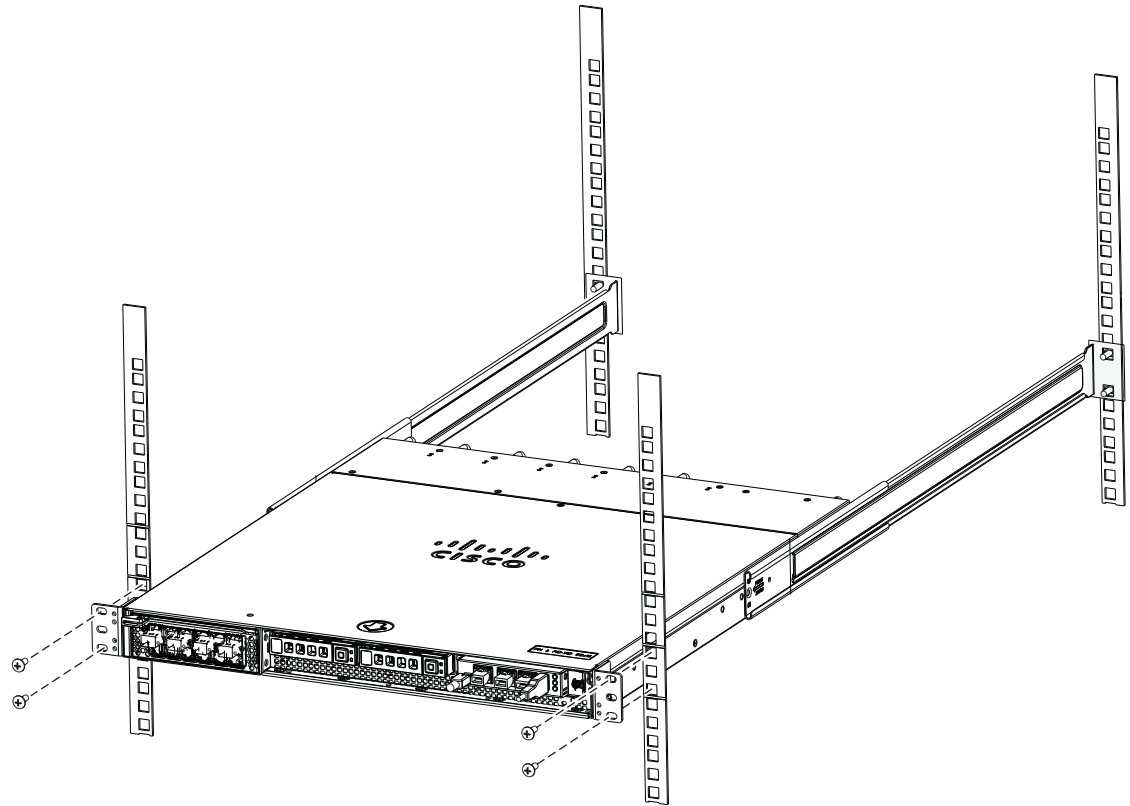

330145

- Step 6** Verify that the chassis is securely installed in the rack.

Front-Mounting in a 2-Post Rack

Follow these steps to front-mount the WAVE appliance in a 2-post rack:



- Note** There must be an empty 1RU space in the rack directly below the chassis to allow space for the back edge to sag. A sag of up to 1/2RU (7/8") is acceptable.

- Step 1** Prepare for installation by reading the “[Rack-Mounting Considerations, Parts, and Tools](#)” section on [page 3-1](#)) and verify that you have the correct tools and rack-mount hardware necessary for the installation.
- Step 2** Attach the front rack mount brackets (item #1 in [Table 3-1](#)) using the six front bracket screws (item #4 in [Table 3-1](#)). (See [Figure 3-4](#).)

Figure 3-4 Attaching the Front Brackets

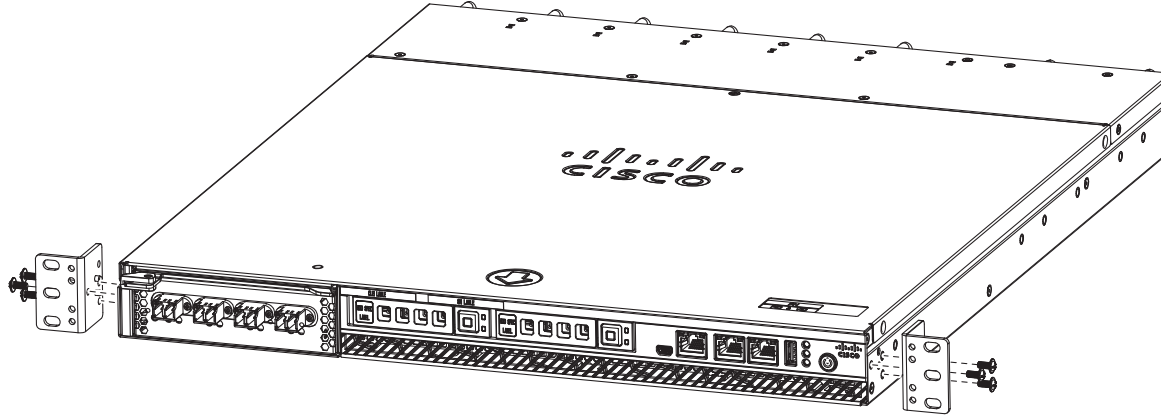

- Step 3** Insert the chassis between the mounting posts and secure (see [Figure 3-5](#)):
- a. Align the mounting holes in the front brackets with the mounting holes in the equipment rack.
 - b. Secure the chassis using four (two on each side) rack screws (item #6 or #7 in [Table 3-1](#)) through the holes in the front brackets and into the threaded holes in the mounting post.
 - c. Use a tape measure and level to ensure that the chassis is installed straight and level.



Note Since the chassis is secured in the rack by the front edge only, there must be an empty 1RU space in the rack directly below the chassis to allow space for the back edge to sag. A sag of up to 1/2RU (7/8") is acceptable.

Figure 3-5 Rack-mounting the Chassis

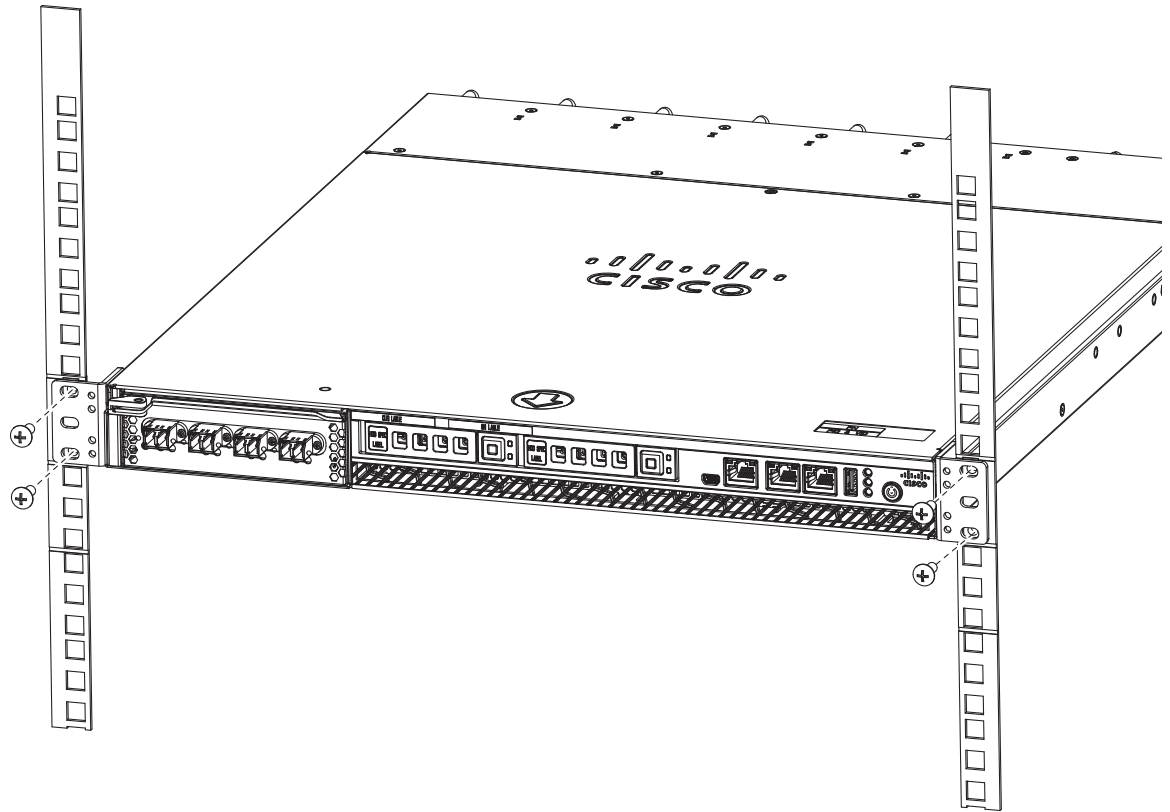

Step 4 Verify that the chassis is securely installed in the rack.

Cabling

Use the following information (see [Figure 3-6](#)) when connecting peripheral cables to the WAVE appliance.



Warning

To reduce the risk of electric shock, fire, or damage to the equipment, do not plug telephone or telecommunications connectors into RJ-45 connectors.

Figure 3-6 Cable Connections—Front

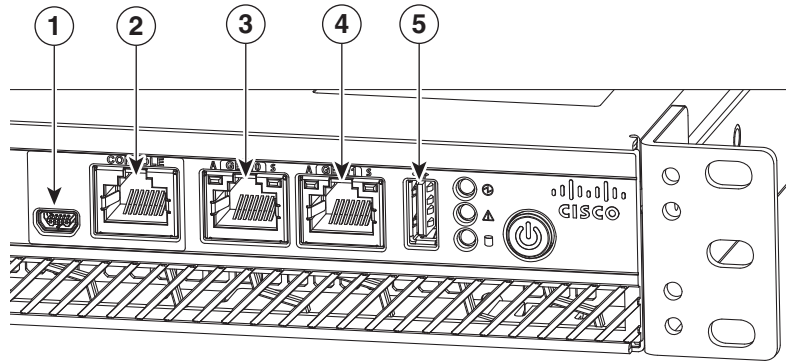

1	Console port (mini-USB)	4	10/100/1000 GE 0/1 connector
2	Console port (RJ-45)	5	External USB port
3	10/100/1000 GE 0/0 connector		

Connecting Power and Booting the System

To connect power to your system, follow these steps:

- Step 1** Review the information in the “[Safety Guidelines](#)” section on [page 2-2](#).
- Step 2** Plug a power cord into the power cord receptacle on the back of the WAVE appliance.
- Step 3** Connect the other end of the power cord to a power source at your installation site.
- Step 4** Power up all externally connected devices.
- Step 5** Press the power control button on the front of the WAVE appliance.

The system should begin booting. Once the operating system boots, you are ready to initialize the basic software configuration. (See the software configuration guide for details.)



Note While the WAVE appliance is powering up, the green power-on LED on the front of the appliance is on.

Checking the LEDs

When the WAVE-594 and WAVE-694 is up and running, observe the front panel LEDs (see [Figure 1-1](#) and [Table 1-1](#)) to verify that your system is operating properly.

To troubleshoot using the LEDs, see [Chapter 6, “Troubleshooting the System Hardware.”](#)

Removing or Replacing a WAVE Appliance

To remove a WAVE appliance from your network, power it down, disconnect the power cords and network cables, and physically remove the chassis from the rack.

The WAVE appliance is in constant communication with the router on your network. When the router notices that the WAVE appliance is no longer responding to it, the router stops sending requests to the WAVE appliance. This action is transparent to users. If other WAVE appliances are attached to the router, the router continues sending requests to the other WAVE appliances.

When you remove a WAVE appliance, the pages that were cached on that appliance are no longer available to the router or other WAVE appliances. You might see an increase in outgoing web traffic that might have otherwise been fulfilled by the WAVE appliance that you are removing. However, after a time, the router and other WAVE appliances redistribute the load of web traffic.

If you remove the last WAVE appliance from your network, you can also disable WAVE support on the router. However, this action is not necessary because leaving WAVE support enabled when there are no WAVE appliances attached has no effect on the router's performance.

To replace a WAVE appliance, remove it from the network, and then install a new WAVE appliance and configure it using the same configuration parameters (IP address and so forth) that you used for the removed WAVE appliance.

Upgrading the WAVE-694 to a New Release

Consider the following guidelines when upgrading the WAVE-694 appliance:

- If you upgrade a WAVE-694 from WAAS Version 5.x to Version 6.x, and the WAVE-694 has the following parameters:
 - 24 GB RAM
 - You have used the **disk object-cache extend** command before the upgrade.

After the upgrade from WAAS Version 5.x to 6.x, you may see the **disk_full** alarm. (For more information on alarms, see of the [WAAS Alarm Book](#).)

To address the above scenario, follow these steps *before* beginning the upgrade process:

- a. Use the **no disk object-cache extend** command to disable the **disk object cache extend** command.
- b. Reload the WAVE-694 in WAAS Version 5.x.
- c. Verify that the device is operational.
- d. Upgrade from WAAS Version 5.x to WAAS Version 6.x.

