



Cisco Remote-PHY Solution Deployment

- [Design Considerations, page 1](#)
- [Network Architecture, page 2](#)
- [Network Topologies, page 2](#)
- [Network Cables, page 5](#)

Design Considerations

This section helps you prepare for deploying the Cisco Remote-PHY solution.

Prerequisites

- Ensure that a digital optical network is deployed between the Cisco Coaxial Media Converter (Cisco CMC) and Cisco CMTS. The supported digital optical networks are EPON, GPON, and Metro Ethernet.
- Ensure that the data path is guaranteed between the Cisco CMTS and the Cisco CMC.
- Reserve sufficient bandwidth for the DOCSIS traffic.
- Network must support IPv4 multicast forwarding.
- Ensure that the maximum latency is as low as possible.
- Based on the input type in the network, deploy or use the appropriate type of Cisco CMC. For RF input, deploy the Cisco CMC with coaxial cable input. For optical input, deploy the Cisco CMC with the FRx.

Memory Requirements

Component	Recommended Memory Requirement
Cisco uBR10012 Router with PRE4	Flash—128 MB DRAM—2 GB
Cisco uBR10012 Router with PRE5	Flash—256 MB DRAM—4 GB

Component	Recommended Memory Requirement
Cisco Coaxial Media Converter	Flash—96 MB DRAM—256 MB

Network Architecture

The Cisco Remote-PHY solution supports the *Single Controller Sharing* architecture. In this architecture, multiple Cisco CMC equipments share the downstream and upstream channels of a Cisco uBR-MC3GX60V-RPHY line card.

Figure 1: Single Controller Sharing Architecture

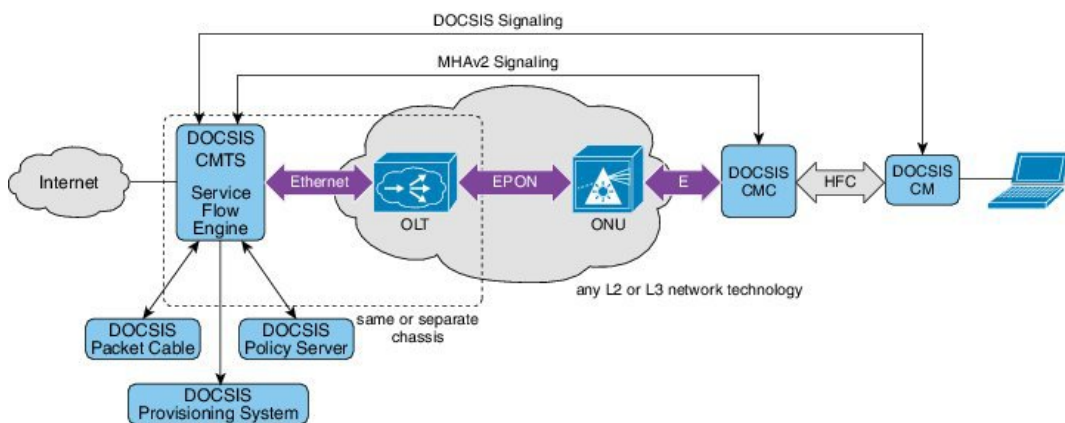

382064

Network Topologies

This section describes some network topologies supported by the Cisco Remote-PHY solution.

Topology 1—Metro Ethernet Topology

Network Elements:

- One Cisco uBR10012 Router
- Hundreds of Cisco CMC devices
- Maximum of eight Cisco uBR-MC3GX60V-RPHY line cards
- Multiple switches

Capacity:

Maximum of 24 Gb on the downstream and 14 Gb on the upstream for one Cisco uBR10012 Router.

Figure 2: Metro Ethernet Topology

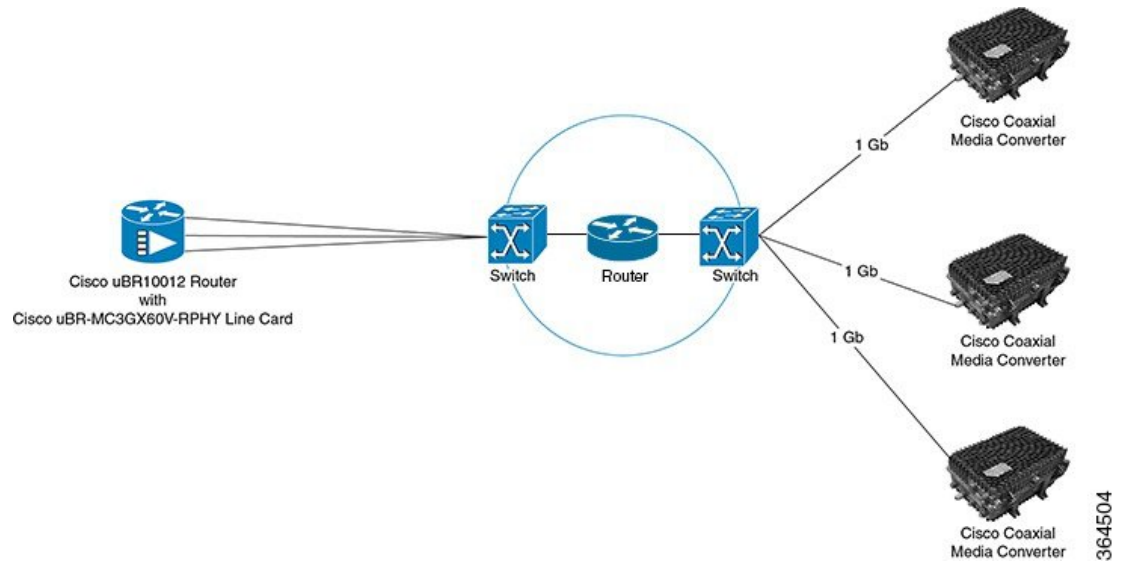

Topology 2—Switch and PON Topology

Network Elements:

- One Cisco uBR10012 Router
- Hundreds of Cisco CMC devices with internal ONU
- Maximum of eight Cisco uBR-MC3GX60V-RPHY line cards
- Multiple PON OLTs
- Multiple switches

Capacity:

Maximum of 24 Gb on the downstream and 14 Gb on the upstream for one Cisco uBR10012 Router.

Figure 3: Switch and PON Topology

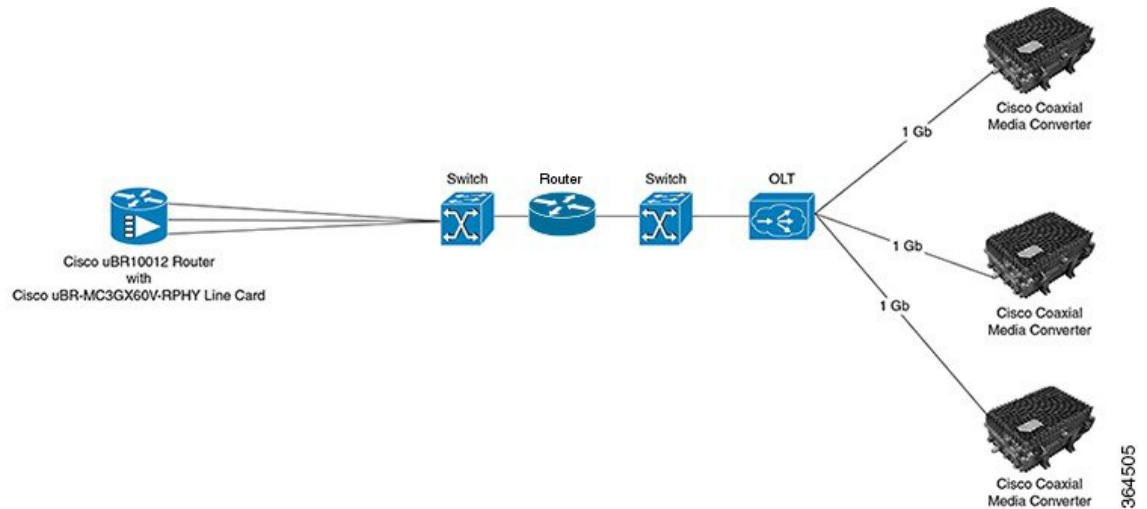

Topology 3—Pure PON Topology

Network Elements:

- One Cisco uBR10012 Router
- Hundreds of Cisco CMC devices with internal ONU
- Maximum of eight Cisco uBR-MC3GX60V-RPHY line cards
- Multiple PON OLTs

Capacity:

Maximum of 24 Gb on the downstream and 14 Gb on the upstream for one Cisco uBR10012 Router.

Figure 4: Pure PON Topology

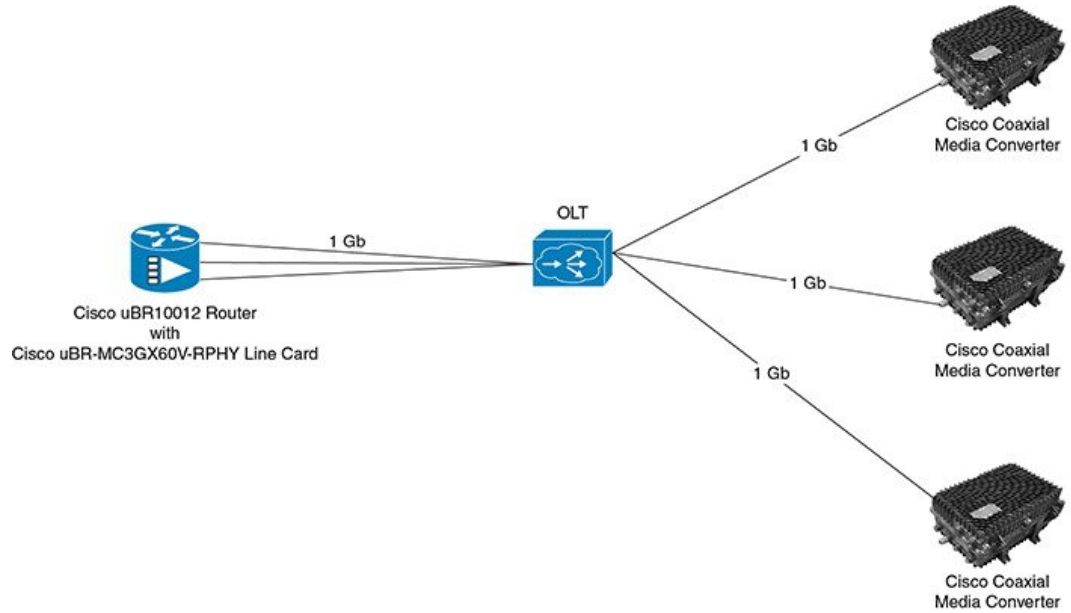

382063

Network Cables

Table 1: Cable Types Supported for the Cisco Remote-PHY Solution

Originating Device	Target Device	Cable Type	Connector Type
CMTS (Gigabit Ethernet SFP module on the Cisco uBR-MC3GX60V-RPHY line card)	Switch or OLT	Ethernet cables	RJ-45 connector
		Copper cables	RJ-45 connector
		Optical fiber	LC Fiber-Optic connector
OLT	ONU	Optical fiber	SC Fiber-Optic connector
	External ONU	Optical fiber	SC Fiber-Optic connector
Switch	Cisco CMC	Optical fiber	LC Fiber-Optic connector
ONU	Cisco CMC	Optical fiber	SC Fiber-Optic connector
External ONU	Cisco CMC	Copper cables	RJ-45 connector

