



## **Cisco cBR Converged Broadband Routers DOCSIS Software Configuration Guide for Cisco IOS XE Dublin 17.12**

**First Published:** 2024-04-29

**Last Modified:** 2024-07-25

### **Americas Headquarters**

Cisco Systems, Inc.  
170 West Tasman Drive  
San Jose, CA 95134-1706  
USA  
<http://www.cisco.com>  
Tel: 408 526-4000  
800 553-NETS (6387)  
Fax: 408 527-0883





## CONTENTS

---

### PART I

---

#### Basic Configuration 79

### CHAPTER 1

<b>Start Up Configuration of the Cisco cBR Router</b>	<b>1</b>
Prerequisites for Configuring the Cisco CMTS	2
Booting and Logging onto the Cisco CMTS	3
First Time Boot Up with ROMMON	3
Configuration Register	4
Setting Environment Variables	5
Unsetting Environment Variables	5
Booting from the TFTP on the Cisco cBR	6
Listing Supported Devices	6
Booting from the Device on the Cisco cBR	7
Setting AUTOBOOT image in ROMMON	7
Verifying the ROMMON Version	8
Resetting the Cisco cBR	9
Configuring PTP	9
Overview of PTP	10
Configure PTP Subordinate Through DPIC	12
Configure Cisco cBR as PTP Subordinate	13
Verifying PTP Subordinate Configuration	14
PTP Subordinate Configuration Examples	14
Feature Information for PTP Subordinate	16
File Systems	16
Verification of Hardware Bring Up	17
Monitoring the Cisco cBR Chassis Using CLI	17
Gigabit Ethernet Management Interface Overview	25

Gigabit Ethernet Port Numbering	25
IP Address Handling in ROMMON and the Management Ethernet Port	25
Gigabit Ethernet Management Interface VRF	26
Common Ethernet Management Tasks	26
Viewing the VRF Configuration	26
Setting a Default Route in the Management Ethernet Interface VRF	27
Setting the Management Ethernet IP Address	27
Telnetting over the Management Ethernet Interface	27
Pinging over the Management Ethernet Interface	27
Copy Using TFTP or FTP	28
NTP Server	28
SYSLOG Server	28
SNMP-Related Services	28
Domain Name Assignment	28
DNS service	29
RADIUS or TACACS+ Server	29
VTY lines with ACL	29
Configuring the AUX Port for Network Management	29
Preprovisioning the Supervisor in the Cisco cBR Chassis	30
Configuring the Gigabit Ethernet Interface for Network Management	30
Configuring the DTI Port on the Supervisor PIC	31
Configuring the TenGigabit Ethernet Interface for Network Management	32
Connecting the New Router to the Network	33
Setting Password Protection on the Cisco CMTS	34
Recovering Lost Password on the Cisco CMTS	34
Saving Your Configuration Settings	36
Reviewing Your Settings and Configurations	37
Recovering Unresponsive Modems	37

---

<b>CHAPTER 2</b>	<b>Cisco Smart Licensing</b>	<b>39</b>
	Hardware Compatibility Matrix for the Cisco cBR Series Routers	39
	Prerequisites for Cisco Smart Licensing	40
	Information About Cisco Smart Licensing	41
	Downstream License	42



Out of Compliance Enforcement	42
How to Configure Cisco Smart Licensing	43
Using Cisco Smart Licensing Agent on the Router	43
Setting Up a Cisco Smart Account	43
Creating Virtual Accounts	50
Creating a Product Instance Registration Token	51
Communication with CSSM	52
Registering the Router with the Cisco Licensing Cloud Using the Registration Token	53
Reestablishing Connectivity to Cisco Smart Call Home Server	54
How to Configure Cisco Smart Licensing using Transport Gateway Solution	54
Configuring 100G Licenses for Supervisor 250G	56
Overview of 100G License for Supervisor 250G	56
Applying 10G WAN License to the 100G WAN Ports	56
Displaying the License Information	57
Feature Information for 100G License for Supervisor 250G	60
Verifying Cisco Smart Licensing Configuration	61
Troubleshooting Cisco Smart Licensing	67
Manually Renewing the Smart License Registration	67
Unregistering the Router from Cisco Smart Licensing	68
Flexible Consumption Model (FCM) Licenses	68
Additional References	73
Feature Information for Cisco Smart Licensing	73

---

**CHAPTER 3**

<b>Core Peak Bandwidth Licensing</b>	<b>75</b>
Core Peak Bandwidth License	75
CPB Calculation	75
Configure CPB on Cisco cBR Routers	76
Enable CPB Licensing	76
View CPB Usage Details	76
Example: Show CPB Usage Details	76
View Details of All Licenses	76
Example: View Details of All Licenses	76
View CPB Sample History	77
Example: View CPB Sample History	77

Feature Information for Core Peak Bandwidth Licensing 77

---

**CHAPTER 4**

**Capped License Enforcement 79**

Hardware Compatibility Matrix for the Cisco cBR Series Routers 79

Information About Capped License Support 81

SNMP-MIB-based Capped Enforcement 81

Use Case Scenarios 81

How to Configure Capped License Enforcement 82

Configuring Capped License Enforcement 82

Viewing the License Usage Count 82

Configuration Examples 82

Feature Information for Capped License Enforcement 83

---

**CHAPTER 5**

**Consolidated Packages and SubPackages Management 85**

Finding Feature Information 85

Running the Cisco cBR Series Routers Using Individual and Optional SubPackages: An Overview 85

Running the Cisco cBR Series Routers Using a Consolidated Package: An Overview 86

Running the Cisco cBR Series Routers: A Summary 86

Software File Management Using Command Sets 87

Managing and Configuring the Router to Run Using Consolidated Packages and Individual SubPackages 88

Cable Line Card Process Restart 89

Cable Line Card Control Plane Process Restart 89

Cable Line Card Upstream Scheduler Process Restart 96

Quick Start Software Upgrade 102

Managing and Configuring a Consolidated Package Using the copy Command 102

Managing and Configuring a Router to Run Using Individual SubPackages From a Consolidated Package 104

Extracting a Consolidated Package and Booting Using the Provisioning File 104

Copying a Set of Individual SubPackage Files, and Booting Using a Provisioning File 106

Installing an Optional SubPackage 107

Upgrading Individual SubPackages 108

Patch Installation 108

Installing a Patch that Affects Both Line Card and Supervisor Card 109

Installing a Patch that Affects Only Line Cards	109
Installing a Patch that Affects Only Supervisor Cards	109
Upgrading a Line Card SubPackage	109
Additional References	117
Feature Information for Consolidated Packages and SubPackages Management	117

**CHAPTER 6****Support for 2x100G DPIC 119**

Hardware Compatibility Matrix for the Cisco cBR Series Routers	119
Information About Cisco cBR 2x100G DPIC	121
Limitations on Downstream Bandwidth	121
Support for Link Redundancy	122
How to Configure 2x100G DPIC	123
View 2x100G DPIC Details	123
Configure 2x100G DPIC Mode	123
Verify 2x100G DPIC Mode	123
Verify 2x100G Ethernet Interface Status	123
Switch Between 8x10G and 2x100G Modes	124
Configure RPD	125
Configure RPD Location Attributes Through CLI	125
Identifying RPD PTP Clock issues Through SNMP Polling	128
Support for 2x4 RPD	129
New TLVs RPD Reset Control Operation	129
Clearing the RPD Reset Control Operation	130
Verifying the RPD Reset Control Operation	131
Configure Link Redundancy	131
Feature Information for 2x100G DPIC Support	132

**CHAPTER 7****G.8275.2 Telecom Profile 133**

G.8275.2 Telecom Profile	133
Information About G.8275.2 Telecom Profile	133
Why G.8275.2 Telecom Profile?	134
PTP Clocks	134
PTP Domain	134
PTP Messages and Transport	135

PTP Ports	135
Alternate BPCA	135
Benefits	135
Restrictions for Using the G.8275.2 Profile	135
How to Configure the G.8275.2 Profile	136
Creating an Ordinary Subordinate (T-TSC-P)	136
Configuring Dual PTP Primary Clocks	136
Configuring the G.8275.2 Profiles	136
Configuring an IPv4 Single Clock Source	137
Configuring an IPv6 Single Clock Source	137
Verifying the G.8275.2 Profile	137
Configuration Examples	137
DPIC PTP Primary	138
Configuring DPIC PTP Primary	138
Verifying the DPIC PTP Primary	141
Feature Information for G.8275.2 Profile	144
<hr/>	
<b>CHAPTER 8</b>	<b>Model-Driven Telemetry 147</b>
Hardware Compatibility Matrix for the Cisco cBR Series Routers	147
Information About Model-Driven Telemetry	149
Restrictions for Model Driven Telemetry	149
Prerequisites to Enable Telemetry	150
Configuring Telemetry	150
Configuring Telemetry using gRPC	150
Configuring Telemetry using NETCONF	152
Feature Information for Model-Driven Telemetry	153
<hr/>	
<b>PART II</b>	<b>High Availability Configuration 155</b>
<hr/>	
<b>CHAPTER 9</b>	<b>Cisco IOS-XE In-Service Software Upgrade Process 157</b>
Hardware Compatibility Matrix for the Cisco cBR Series Routers	157
Information about In-Service Software Upgrade	159
How to Configure In-Service Software Upgrade	159
Configuring Subpackage Upgrade	159

Subpackages Upgrade	159
Line Card Only In-Service Software Upgrade	160
ISSU Upgrade Across Major Releases	161
Additional References	162
Feature Information for In-Service Software Upgrade	162

**CHAPTER 10****Supervisor Redundancy 163**

Hardware Compatibility Matrix for the Cisco cBR Series Routers	163
Prerequisites for Supervisor Redundancy	165
Information About Supervisor Redundancy	165
Switchover Procedure	165
Using Redundant File Systems	166
Console Port Usage After Supervisor Switchover	168
Benefits	168
How to Configure Supervisor Redundancy	168
Forcing Switchover	169
Changing the System Boot Behavior	170
Saving a Configuration File to the Bootflash or Hard Disk	173
Verifying the Supervisor Redundancy Configuration	173
Verifying Supervisor Redundancy	173
Verifying Supervisor Switchover	176
Configuration Example for Supervisor Redundancy	177
Additional References	178
Feature Information for Supervisor Redundancy	178

**CHAPTER 11****Line Card Redundancy 179**

Hardware Compatibility Matrix for the Cisco cBR Series Routers	179
Prerequisites for Line Card Redundancy	181
Restrictions for Line Card Redundancy	181
Information About Line Card Redundancy	182
How to Configure Line Card Redundancy	182
Configuring Line Card Manual Switchover	183
Configuring N+1 Line Card Redundancy	183
Verifying the Line Card Redundancy Configuration	184

Enabling LCHA When DPIC Fails 188  
 Additional References 190  
 Feature Information for Line Card Redundancy 191

---

**PART III Support For DOCSIS 4.0 193**

---

**CHAPTER 12 Registering DOCSIS 4.0 Modems as DOCSIS 3.1 Modems 195**  
 Registering DOCSIS 4.0 Modems as DOCSIS 3.1 Modems 195

---

**PART IV Layer 2 and DOCSIS 3.0 Configuration 199**

---

**CHAPTER 13 Downstream Interface Configuration 201**  
 Finding Feature Information 201  
 Hardware Compatibility Matrix for the Cisco cBR Series Routers 201  
 Information About Downstream Interface Configuration 203  
 How to Configure Downstream Interfaces 205  
     Configuring the Cisco CMTS Manually Using Configuration Mode 205  
     Configuring the QAM Profile on the Downstream Channels 205  
     Configuring the Frequency Profile on the Downstream Channels 206  
     Configuring the Controller on the Downstream Channels 207  
         Troubleshooting Tips 208  
     Configuring the RF Channel on a Controller 208  
 Configuration Examples 209  
 Additional References 212  
 Feature Information for Downstream Interface Configuration on the Cisco cBR Router 213

---

**CHAPTER 14 Upstream Interface Configuration 215**  
 Finding Feature Information 215  
 Hardware Compatibility Matrix for the Cisco cBR Series Routers 215  
 Information About Upstream Interface Configuration 217  
 How to Configure Upstream Interfaces 217  
     Configuring the Cisco CMTS Manually Using Configuration Mode 217  
     Configuring the Modulation Profile and Assigning to an Upstream Channel 218  
     Configuring the Upstream Channel with PHY Layer 218

Associating Upstream Channels with a MAC Domain and Configuring Upstream Bonding	219
Configuring Upstream Channel Priority	221
Configuration Examples	221
Additional References	222
Feature Information for Upstream Interface Configuration on the Cisco cBR Router	222

---

**CHAPTER 15**
**DOCSIS Interface and Fiber Node Configuration 223**

Hardware Compatibility Matrix for the Cisco cBR Series Routers	223
Overview of DOCSIS Interfaces and Fiber Node Configurations	225
Downstream Features	225
Upstream Features	226
MAC Domains (Cable Interfaces)	226
Fiber Nodes	226
Configuring DOCSIS Interfaces and Fiber Nodes	226
Configuring Upstream Channels	226
Verifying the Controller Configuration	226
Binding Upstream Channels to MAC Domain	227
Configuring Primary Capable Downstream Channels	228
Verifying Downstream Configuration in Controller	228
Configuring Integrated-cable Interface	228
Binding Primary Capable Downstream Channels to a MAC Domain	230
Configuring MAC Domain Service Groups	232
Configuring the Fiber Nodes	232
Verify MD-DS-SG Channel Membership	234
Verify MD-US-SG Channel Membership	234
Downstream Bonding Group Configuration	235
Configuring Wideband-cable Interface (Downstream Bonding Grouping)	235
Verifying the Bonding Group Interfaces	236
Upstream Bonding Group Configuration	238
Restrictions for Upstream Bonding Groups	238
Configuring Upstream Bonding Groups	239
Verifying Upstream Bonding Groups	240
Additional References	241
Feature Information for DOCSIS Interface and Fiber Node Configuration	242

---

<b>CHAPTER 16</b>	<b>Service Group Based Configuration of the Cisco cBR Router</b>	<b>243</b>
	Service Group Profile Based Configuration	243
	Service Profile Configuration for 16x8 with One MAC Domain	245
	Service Profile Configuration for 16x8 with Two MAC Domains	247
	MAC-Domain Split Configuration	249

---

<b>CHAPTER 17</b>	<b>DOCSIS Load Balancing Groups</b>	<b>253</b>
	Hardware Compatibility Matrix for the Cisco cBR Series Routers	253
	Prerequisites for DOCSIS Load Balancing Groups	255
	Restrictions for DOCSIS Load Balancing Groups	255
	Information About DOCSIS Load Balancing Groups	256
	Service-Based Load Balancing	256
	RLBG/GLBG Assignment	257
	Channel Assignment	258
	Upstream Load Balancing for DOCSIS 3.0 Cable Modems in Single Upstream Mode	261
	Auto-generate DOCSIS 2.0 GLBG	261
	Independent Upstream/Downstream Throughput Rules	261
	How to Configure DOCSIS Load Balancing Groups	262
	Configuring DOCSIS 3.0 and 2.0 RLBG and DOCSIS 2.0 GLBG	263
	Configuring DOCSIS 3.0 GLBG	265
	Configuring a DOCSIS 3.0 General Load Balancing Group	266
	Configuring Default Values of DOCSIS 3.0 Load Balancing Group	267
	Configuring Cable Modems to RLBG or a Service Type ID	268
	Configuring Rules and Policies	269
	Troubleshooting Tips	269
	Configuring Load Balancing Parameter for a Cable Modem Movement Failure	270
	Creating and Configuring TLV type Tag	270
	Configuration Examples for DOCSIS Load Balancing Groups	272
	Example: Configuring a Tag	272
	Example: Disabling Load Balancing	273
	How to Configure Load Balancing with Operational Simplification	273
	Load Balancing Groups with Operational Simplification	276
	Verifying DOCSIS Load Balancing Groups	277



Additional References 282

Feature Information for DOCSIS Load Balancing Groups 282

---

**CHAPTER 18**

**DOCSIS Load Balancing Movements 283**

Hardware Compatibility Matrix for the Cisco cBR Series Routers 284

Prerequisites 286

Prerequisites for Load Balancing 286

Prerequisites for Dynamic Channel Change for Load Balancing 286

Prerequisites for Dynamic Bonding Change for DOCSIS 3.0 Static Modem Count-Based Load Balancing 286

Restrictions 286

Restrictions for Load Balancing 286

Restrictions for Dynamic Channel Change for Load Balancing 288

DCC Restrictions with N+1 Redundancy and Inter-Card Load Balancing 289

Restrictions for DOCSIS 3.0 Static Modem Count-Based Load Balancing 289

Restrictions for Dynamic Bonding Change for DOCSIS 3.0 Static Modem Count-Based Load Balancing 290

Restrictions for MRC-Only Cable Modems 290

Information on the Load Balancing on the Cisco CMTS 291

Feature Overview 291

Methods to Determine When Interfaces Are Balanced 292

Modems Method 292

Utilization Method 292

Load Balancing Parameters 293

Configurable Minimum Threshold under Utilization Method 293

Single Channel Load Balancing 294

Error Handling of Channel Assignment 294

Downstream Load Balancing Distribution with Upstream Load Balancing 294

Upstream Load Balancing for DOCSIS 3.0 Cable Modems in Single Upstream Mode 295

Interaction with Spectrum Management 295

Using Dynamic Channel Change 296

Multiple Channel Load Balancing 296

Algorithm for Bonded Channel Cable Modem Load Balancing 296

DOCSIS 3.0 Static Modem Count-Based Load Balancing 296

Dynamic Load Balancing for DOCSIS 3.0 Cable Modems	299
Multiple Channel Load Balancing Operation	299
Using DBC for DOCSIS 3.0 Load Balancing Movement	303
Benefits of Load Balancing	305
Exclude Cable Modems from Load Balancing Groups	306
How to Configure Load Balancing	306
Enabling Single Channel Load Balancing	307
Configuring Dynamic Bonding Change for DOCSIS 3.0 Static Load Balancing	307
Excluding Cable Modems from a Load Balancing Group	307
Distributing Downstream Load Balancing with Upstream Load Balancing	308
How to Configure Dynamic Channel Change for Load Balancing	309
Configuring Dynamic Channel Change for Load Balancing	310
Verifying Load Balancing Operations	311
Example	312
Troubleshooting Tips	313
Configuration Examples for Load Balancing	315
Example: Configuring Dynamic Channel Change for Load Balancing	316
Additional References	319
Feature Information for DOCSIS Load Balancing Movements	319

---

**CHAPTER 19**
**DOCSIS 3.0 Downstream Bonding 321**

Hardware Compatibility Matrix for the Cisco cBR Series Routers	321
Information About DOCSIS 3.0 Downstream Bonding	323
Receive Channel Profile	323
Receive Channel Configuration	323
RCC Template	323
Channel Assignment	324
Downstream Traffic Forwarding	324
Service Flow Priority in Downstream Extended Header	324
How to Configure RCP and RCC Encoding	324
Configuring the RCP ID	324
Configuring the RCC Templates	327
Assigning an RCC Template to a MAC Domain (Cable Interface)	330
Verifying the RCC Configuration	333

How to Configure Attribute Masks	333
Configuring Provisioned Attributes for an Integrated Cable Interface	334
Configuring Provisioned Attributes for a Wideband Cable Interface	335
Verifying the Attribute-Based Service Flow Assignments	336
How to Enable Service Flow Priority in Downstream Extender Header	337
Enabling Service Flow Priority in Downstream Extender Header	337
Verifying the Enablement of the Service Flow Priority in Downstream Extended Header	338
Enabling Verbose Reporting for Receive Channel Profiles	339
Configuration Example for an RCC Template	340
Additional References	341
Feature Information for DOCSIS 3.0 Downstream Bonding	341

---

**CHAPTER 20**
**DOCSIS 2.0 A-TDMA Modulation Profiles 343**

Hardware Compatibility Matrix for the Cisco cBR Series Routers	343
Prerequisites for DOCSIS 2.0 A-TDMA Modulation Profiles	345
Restrictions for DOCSIS 2.0 A-TDMA Services	345
Information About DOCSIS 2.0 A-TDMA Services	345
Modes of Operation	346
Modulation Profiles	348
Benefits	348
How to Configure DOCSIS 2.0 A-TDMA Services	348
Creating Modulation Profiles	348
Creating a TDMA Modulation Profile	349
Creating a Mixed Mode Modulation Profile	349
Creating an A-TDMA Modulation Profile	350
Configuring the DOCSIS Mode and Profile on an Upstream	351
Monitoring the DOCSIS 2.0 A-TDMA Services	352
Displaying Modulation Profiles	353
Displaying Cable Modem Capabilities and Provisioning	353
Configuration Examples for DOCSIS 2.0 A-TDMA services	355
Creating Modulation Profiles Examples	355
Example: DOCSIS 1.0/DOCSIS 1.1 TDMA Modulation Profiles	355
Example: Mixed TDMA/A-TDMA Modulation Profiles	355
Example: DOCSIS 2.0 A-TDMA Modulation Profiles	356

Assigning Modulation Profiles to Upstreams Examples	356
Example: Assigning DOCSIS 1.0/DOCSIS 1.1 TDMA Modulation Profiles	357
Example: Assigning Mixed TDMA/A-TDMA Modulation Profiles	357
Example: Assigning DOCSIS 2.0 A-TDMA Modulation Profiles	357
Additional References	358
Feature Information for DOCSIS 2.0 A-TDMA Modulation Profile	359

**CHAPTER 21****Downstream Resiliency Bonding Group 361**

Hardware Compatibility Matrix for the Cisco cBR Series Routers	362
Prerequisites for Downstream Resiliency Bonding Group	363
Restrictions for the Downstream Resiliency Bonding Group	363
Information About Downstream Resiliency Bonding Group	364
Finding a Best-Fit RBG for the Cable Modem	365
How to Configure Downstream Resiliency Bonding Group	366
Enabling Downstream Resiliency Bonding Group	366
Reserving a Resiliency Bonding Group for a Line Card	367
Moving a DS Partial Cable Modem Back to the Original BG	368
Verifying Downstream Resiliency Bonding Group Configuration	368
Verifying the Downstream Resiliency Bonding Group	368
Verifying a Reserved Resiliency Bonding Group	369
Downstream Resiliency Narrowband Mode Versus Resiliency Bonding Group	369
Troubleshooting the Downstream Resiliency Bonding Group Configuration	373
Configuration Examples for the Downstream Resiliency Bonding Group	373
Excluding Cable Modems from Downstream Resiliency Operations	377
Additional References	378
Feature Information for Downstream Resiliency Bonding Group	378

**CHAPTER 22****Downstream Channel ID Assignment 381**

Hardware Compatibility Matrix for the Cisco cBR Series Routers	381
Information About Downstream Channel ID Assignment on the Cisco CMTS Routers	383
Manual Downstream Channel ID Assignment	383
Automatic Downstream Channel ID Assignment on the Cisco CMTS Routers	384
How to Configure Downstream Channel ID Assignment on the Cisco CMTS Routers	385
Configuring Manual Downstream Channel ID Assignment	385

Configuring Automatic Downstream Channel ID Assignment	386
Additional References	389
Feature Information for Downstream Channel ID Assignment	389

---

**CHAPTER 23**
**Upstream Channel Bonding 391**

Hardware Compatibility Matrix for the Cisco cBR Series Routers	391
Prerequisites for Upstream Channel Bonding	393
Restrictions for Upstream Channel Bonding	393
Information About Upstream Channel Bonding	395
Multiple Transmit Channel Mode	396
Multiple Receive Channel Mode	396
Dynamic Range Window and Transmit Power Levels for Upstream Channel Bonding	396
Extended Transmit Power	397
Reduced Transmit Channel Set	398
T4 Multiplier	399
Fiber Node Configuration for Upstream Channel Bonding	399
New TLVs for Upstream Channel Bonding	399
Upstream Weighted Fair Queuing	401
Class-Based Weighted Fair Queuing	401
Activity-Based Weighted Fair Queuing	401
Custom Weight for Service Flow Priorities	401
Upstream Scheduler and Service Flows	402
Upstream Service Flow Fairness	402
Distribution of Traffic across all Channels in a USBG	403
DOCSIS 3.0 Load Balancing with USBG Smaller than Cable Modem Capabilities	403
Cisco cBR-8 CCAP Line Card Rate Limiting	403
SID Tracking	404
Service ID Clusters	404
How to Configure Upstream Channel Bonding	404
Enabling MTC Mode on a Cisco CMTS Router	405
Default MTC Mode Configuration on a Cisco CMTS Router	405
Enabling MTC Mode for All CMs	405
Configuring UCSB Required Attribute	406
Creating a Bonding Group	407

Adding Upstream Channels to a Bonding Group	407
Adding Upstream Channel Ports to a Fiber Node	409
Configuring the Class-Based Weighted Fair Queuing	410
Configuring the Activity-Based Weighted Fair Queuing	410
Configuring Custom Weights for Service Flow Priorities	411
Configuring the SID Cluster	412
Configuring the Channel Timeout for a Cable Modem	413
Configuring Cable Upstream Resiliency	414
Configuring Rate Limiting on the Cisco cBR-8 CCAP Line Card	415
Enabling Upstream Related Events for CM Status Reports	416
Modifying the Bonding Group Attributes	416
Modifying the Ranging Poll Interval on Upstream Channels	417
Configuring the Reduced Channel Set Assignment	418
Configuring DOCSIS Extended Transmit Power Feature	419
Troubleshooting Tips	420
Configuration Example for Upstream Channel Bonding	420
Example: Enabling MTC Mode for a Single CM Using the CM Configuration File	422
Verifying the Upstream Channel Bonding Configuration	422
Verifying Weighted Fair Queuing for Upstream Service Flows	422
Verifying Rate Limiting for Upstream Bonded Service Flows	423
Verifying Extended Power Transmission	423
Additional References	423
Feature Information for Upstream Channel Bonding	423

---

**CHAPTER 24**
**Dynamic Bonding Group 425**

Hardware Compatibility Matrix for the Cisco cBR Series Routers	425
Information About Dynamic Bonding Group	427
Overview of Dynamic Bonding Group	427
How to configure Dynamic Bonding Group	428
Enable Dynamic Bonding Group	428
Enable DS-Resiliency and Configure Resiliency Bonding Group	429
Enable ACFE	429
Configure Interface Mac-Domain and Fiber-Node	429
Enable Load Balancing for DOCSIS 3.0 and DOCSIS 3.1	431

Enable DOCSIS 3.0 and DOCSIS 3.1 Static Load Balance	431
Enable DOCSIS 3.0 and DOCSIS 3.1 General Load Balance Group	431
Enable Dynamic Load Balance and Fixed-Primary Channel Movement	432
Verifying Dynamic Bonding Group Configuration	433
Verifying Static Load Balancing Configuration	435
Verifying Dynamic Load Balancing Configuration	437
Feature Information for Dynamic Bonding Group	439

**CHAPTER 25****Spectrum Management and Advanced Spectrum Management 441**

Finding Feature Information	441
Hardware Compatibility Matrix for the Cisco cBR Series Routers	442
Prerequisites for Spectrum Management	443
Restrictions for Spectrum Management	443
Shared Spectrum Groups	443
Dynamic Upstream Modulation	444
Fixed-Frequency Spectrum Groups with Advanced Spectrum Management	444
Limitations on Upstream Modulation Parameters for PacketCable VoIP Calls	444
N+1 Redundancy Support	444
Intelligent and Advanced Spectrum Management Support	444
Information About Spectrum Management	445
Spectrum Management Measurements	446
Signal and Carrier Noise Ratios	446
Differences Between the MER (SNR) and CNR (CNiR) Values	447
SNR Smoothing	448
Additional Measurements	449
Upstream Signal Channel Overview	450
Upstream Segments and Combiner Groups	451
Frequency Management Policy	452
Noise Impairments	453
Spectrum Groups and Frequency Hopping	453
Guidelines for Spectrum Management	454
Guided and Scheduled Spectrum Management	454
Frequency Hopping Capabilities	454
Dynamic Upstream Modulation (MER [SNR]-Based)	456

Input Power Levels	458
Intelligent and Advanced Hardware-Based Spectrum Management	459
Intelligent Spectrum Management Enhancements	459
Benefits	459
Guided and Scheduled Spectrum Management Benefits	459
Intelligent and Advanced Spectrum Management Benefits	460
How to Configure Spectrum Management	461
Guided and Scheduled Spectrum Management Configuration Tasks	462
Creating and Configuring Spectrum Groups	462
Assigning a Spectrum Group to One or More Upstream Ports	464
Configuring Shared Spectrum Groups (Fiber Node Groups) for DOCSIS 3.0	465
Configuring Dynamic Upstream Modulation (MER [SNR]-Based)	465
Verifying Frequency Hopping	467
Intelligent and Advanced Spectrum Management Configuration Tasks	471
Configuring and Assigning Spectrum Groups	471
Configuring Dynamic Upstream Modulation (CNR-Based)	471
Configuring Proactive Channel Management	473
Verifying the Spectrum Management Configuration	475
Monitoring Spectrum Management	478
Using CLI Commands	478
Using SNMP	479
ccsSNRRequestTable	480
ccsSpectrumRequestTable	480
ccsSpectrumDataTable	481
ccsUpSpecMgmtTable	481
ccsHoppingNotification	483
Configuration Examples	484
Spectrum Group and Combiner Group Examples	484
Example: Verifying Spectrum Group Creation	484
Example: Time-Scheduled Spectrum Group	484
Example: Verifying Spectrum Group Configuration	484
Example: Determining the Upstream Ports Assigned to a Combiner Group	485
Example: Combiner Group	485
Example: Other Spectrum Management Configurations	487



Dynamic Upstream Modulation Examples	488
Verifying Your Settings	488
Example: Modulation Profiles	488
Example: Input Power Level	490
Advanced Spectrum Management Configuration Examples	490
Example: Advanced Spectrum Management for the Cisco cBR Series Routers	490
Additional References	491
Feature Information for Spectrum Management and Advanced Spectrum Management	492

**CHAPTER 26**

<b>Upstream Scheduler Mode</b>	<b>493</b>
Finding Feature Information	493
Hardware Compatibility Matrix for the Cisco cBR Series Routers	493
Restrictions for Upstream Scheduler Mode	495
Information About Upstream Scheduler Mode for the Cisco CMTS Routers	495
How to Configure Upstream Scheduler Modes	495
Additional References	497
Feature Information for Upstream Scheduler Mode	497

**CHAPTER 27**

<b>Generic Routing Encapsulation</b>	<b>499</b>
Finding Feature Information	499
Hardware Compatibility Matrix for the Cisco cBR Series Routers	500
Restrictions for Implementing Tunnels	501
Restrictions for GRE IPv6 Tunnels	502
Information About Implementing Tunnels	502
Tunneling Versus Encapsulation	502
Tunnel ToS	502
Path MTU Discovery	503
QoS Options for Tunnels	503
Information About IPv6 over IPv4 GRE Tunnels	504
Overlay Tunnels for IPv6	504
GRE IPv4 Tunnel Support for IPv6 Traffic	505
Information About GRE IPv6 Tunnels	506
Overview of GRE IPv6 Tunnels	506
How to Implement Tunnels	506

Determining the Tunnel Type	506
Configuring an IPv4 GRE Tunnel	507
GRE Tunnel Keepalive	507
What to Do Next	509
Configuring 6to4 Tunnels	510
What to Do Next	511
Verifying Tunnel Configuration and Operation	511
Configuration Examples for Implementing Tunnels	513
Example: Configuring a GRE IPv4 Tunnel	513
Configuring QoS Options on Tunnel Interfaces Examples	514
Policing Example	515
How to Configure IPv6 over IPv4 GRE Tunnels	516
Configuring GRE on IPv6 Tunnels	516
Configuration Examples for IPv6 over IPv4 GRE Tunnels	517
Example: GRE Tunnel Running IS-IS and IPv6 Traffic	517
Example: Tunnel Destination Address for IPv6 Tunnel	518
How to Configure GRE IPv6 Tunnels	518
Configure CDP Over GRE IPv6 Tunnels	518
Configuration Examples for GRE IPv6 Tunnels	520
Example: Configuring CDP Over GRE IPv6 Tunnels	520
Additional References	520
Feature Information for Generic Routing Encapsulation	522
<hr/>	
<b>CHAPTER 28</b>	<b>Transparent LAN Service over Cable 523</b>
Hardware Compatibility Matrix for the Cisco cBR Series Routers	523
Prerequisites for Transparent LAN Service over Cable	525
Restrictions for Transparent LAN Service over Cable	525
Information About Transparent LAN Service over Cable	526
Feature Overview	526
Transparent LAN Service and Layer 2 Virtual Private Networks	526
IEEE 802.1Q Mapping	526
Overview	527
Details of IEEE 802.1Q Mapping	527
Benefits	527

How to Configure the Transparent LAN Service over Cable	528
Configuring IEEE 802.1Q VLAN Mapping	528
Enabling and Configuring Layer 2 Tunneling for IEEE 802.1Q Mapping	528
Creating the IEEE 802.1Q VLAN Bridge Group	529
Configuration Examples for Transparent LAN Service over Cable	530
Example: Configuring IEEE 802.1Q VLAN Mapping	530
Example: Configuring IEEE 802.1Q Bridge Aggregator	531
Verifying the Transparent LAN Service over Cable Configuration	532
Additional References	533
Feature Information for Transparent LAN Service over Cable	533

**CHAPTER 29****Downgrading Channel Bonding in Battery Backup Mode 535**

Hardware Compatibility Matrix for the Cisco cBR Series Routers	535
Prerequisites for Downgrading Channel Bonding in Battery Backup Mode	537
Restrictions for Downgrading Channel Bonding in Battery Backup Mode	537
Information About Downgrading Channel Bonding in Battery Backup Mode	538
How to Configure Downgrading Channel Bonding in Battery Backup Mode	539
Configuring Channel Bonding Downgrade in Battery Backup Mode Globally	539
Configuring Channel Bonding Downgrade in Battery Backup Mode for MAC Domain	540
Verifying the Configuration for Channel Bonding Downgrade in Battery Backup Mode	541
Additional References	544
Feature Information for Downgrading Channel Bonding in Battery Backup Mode	545

**CHAPTER 30****Upstream Bonding Support for D-PON 547**

Hardware Compatibility Matrix for the Cisco cBR Series Routers	547
Prerequisites for Upstream Bonding Support for D-PON	548
Restrictions for Upstream Bonding Support for D-PON	549
Information About Upstream Bonding Support for D-PON	550
D-PON on Upstream Scheduling	550
How to Configure Upstream Bonding Support for D-PON	551
Verifying the Upstream Bonding Support for D-PON	552
Additional References	552
Feature Information for Upstream Bonding Support for D-PON	553

## CHAPTER 31

**Energy Management Mode 555**

- Information About Energy Management Mode 555
  - Dynamic Downstream Bonding Group 555
  - Flow Chart of the CM Power State 556
  - Interaction with the Battery Mode 557
  - Handling Energy Management Request Load 559
  - Supervisor High Availability and Line Card Switchover 559
- Prerequisites for Energy Management Mode 559
- Restrictions for the Energy Management Mode 559
  - Restrictions for CMTS High Availability 559
  - Restrictions for Dynamic Bonding Group 560
  - Restrictions for Interaction of CMTS with Other Features 560
    - Voice 560
  - Dynamic Bonding Change and Dynamic Channel Change and Related Applications 560
  - Multicast 560
  - Committed Information Rate 560
  - Admission Control 561
  - Battery Mode 561
  - Attribute Mask 561
  - Dynamic Service Addition 561
- Restrictions for Configuration Change and Interface Shutdown 561
- How to Configure the Energy Management Mode 562
  - Enabling Energy Management Mode 562
  - Enabling Energy Management Mode per MAC Domain 563
  - Configuring Initialization Ranging Technique in Dynamic Bonding Channel 563
  - Configuring the Percentage for the Dynamic Channel Bandwidth 563
  - Configuring the Queue Size for Energy Management 563
- Verifying the Energy Management Mode 563
  - Viewing the Basic Statistics for Energy Management Receive Request 564
  - Verifying the Configuration Parameters 564
  - Viewing Information Regarding a Cable Modem 564
- Feature Information for Energy Management Mode 566

---

**CHAPTER 32****Cable Modem Steering 567**

- Cable Modem Steering on the Cisco cBR Series Converged Broadband Routers 567
- Prerequisites for Cable Modem Steering 568
- Restrictions for Cable Modem Steering 568
- Information About Cable Modem Steering 568
  - Upstream Channel Descriptor TLV for Ranging Hold-off 569
    - Ranging Class ID 569
    - Cable Modem Exclusion for DOCSIS Load Balance 569
- How to Configure Cable Modem Steering on the CMTS Router 570
  - Configuring an Upstream Channel Class ID 570
  - Configuring an Upstream Ranging Hold-off Priority Value 571
- Verifying and Troubleshooting Cable Modem Steering 572
  - Verifying an Upstream Ranging Class ID Configuration 572
- Additional References 574
- Feature Information for Cable Modem Steering 575

---

**CHAPTER 33****DOCSIS Predictive Scheduler 577**

- Information about DOCSIS Predictive Scheduler 577
- Configuring DPS on Cable Interface 578
- Displaying DPS Grants on Upstream Channel 578
- Displaying DPS Grants for Cable Modem 578
- Displaying Upstream Utilization 579
- Displaying Upstream Capacity Reserved for Contention Minislot 581
- DOCSIS Predictive Scheduler Best Practices 581
  - MIBs 581
  - Load Balancing 581
  - Contention Based Bandwidth Requests 581
  - MAP Advance Time 582
  - Cable Modem Interoperability 582
  - TaFDM 582
- Feature Information for DOCSIS Predictive Scheduler 582

---

**PART V****Layer 2 and DOCSIS 3.1 Configuration 585**

---

<b>CHAPTER 34</b>	<b>DOCSIS 3.1 OFDM Channel Configuration</b>	<b>587</b>
	Hardware Compatibility Matrix for the Cisco cBR Series Routers	587
	Information about OFDM Channel Configuration	589
	OFDM Channels	589
	Channel Profile	599
	Modulation Profile	599
	OFDM Channel Exclusion Band	599
	How to Configure OFDM Channel	599
	Configuring OFDM Modulation Profile	599
	Verifying OFDM Modulation Profile Configuration	600
	Configuring OFDM Channel Profile	601
	Verifying OFDM Channel Profile Configuration	601
	Configuring OFDM Channel as Primary Channel	602
	Verifying OFDM Primary Channel Configuration	602
	Configuring Port or Controller and Channel	603
	Verifying Port/Controller and Channel Configuration	604
	Configuration Examples	607
	Additional References	608
	Feature Information for DOCSIS 3.1 OFDM Channel Configuration	609
<hr/>		
<b>CHAPTER 35</b>	<b>OFDM Channel Power Profile</b>	<b>611</b>
	Hardware Compatibility Matrix for the Cisco cBR Series Routers	611
	Information About OFDM Channel Power Profile	613
	Restrictions for Configuring OFDM Power Profile	613
	How to Configure the OFDM Channel Power Profile	614
	Configuring OFDM Power Profile Using Band-index	614
	Verifying the Power Profile Configuration	614
	Configuring OFDM Power Profile with Linear Power-tilt	615
	Verifying the Power Profile Using show controller Command	615
	Configuration Example for OFDM Power Profile	615
	Feature Information for OFDM Channel Power Profile	616
<hr/>		
<b>CHAPTER 36</b>	<b>DOCSIS 3.1 Path Selection</b>	<b>617</b>

Information about Path Selection	617
How to Configure Path Selection	617
Configuring Downstream Bonding Group with OFDM Channel	617
Verifying Downstream Bonding Group with OFDM Channel Configuration	618
Configuring Upstream Bonding Group with OFDMA Channel	618
Verifying Upstream Bonding Group with OFDMA Channel Configuration	618
Verifying the Path Selection Status	619
Clearing the Path Selection Status	619
Verifying the RCC Configuration	619
Additional References	621
Feature Information for DOCSIS 3.1 Path Selection	621

**CHAPTER 37****DOCSIS 3.1 Downstream Profile Selection 623**

Hardware Compatibility Matrix for the Cisco cBR Series Routers	623
Information about Downstream Profiles	625
Default Data Profile	625
Recommended Profile	625
Unfit Profile	625
Moving OFDM Profiles Out Of Unfit Profile List	628
Clearing OFDM Unfit Profile List	629
How to Configure Profiles	631
OFDM Profile Downgrade	631
Types of OFDM Profile Downgrade	632
Bit Loading Based OFDM Profile Downgrade	632
Capacity Based OFDM Profile Downgrade	634
Configuring RxMER to Bit Loading Mapping	636
Hitless OFDM Profile Changes	636
Ephemeral Profile to Cable Modem Assignment	637
Display the Cable Modem Count per Profile	638
Additional References	639
Feature Information for Downstream Profile Selection	639

**CHAPTER 38****DOCSIS 3.1 Commanded Power for Upstream SC-QAMs 641**

Hardware Compatibility Matrix for the Cisco cBR Series Routers	641
--	-----

Information About Commanded Power Feature for Upstream SC-QAMs 643

Feature TLVs 643

    TLVs Affected by Commanded Power for US SC-QAMs 643

    Commanded Power Sub-TLVs 643

Additional References 644

Feature Information for Commanded Power for US SC-QAMs 644

---

**CHAPTER 39**

**DOCSIS3.1 Downstream Resiliency for OFDM channel 647**

Hardware Compatibility Matrix for the Cisco cBR Series Routers 647

Information about DOCSIS3.1 Downstream Resiliency for OFDM Channel 649

How to Configure DOCSIS3.1 Downstream Resiliency for OFDM Channel 650

    Configuring DOCSIS3.1 Downstream Resiliency for OFDM Channel 650

    Displaying OFDM Specific CM-STATUS Events 650

    Managing Profile Zero CM-STATUS Events 651

Feature Information for DOCSIS3.1 Downstream Resiliency for OFDM Channel 653

---

**CHAPTER 40**

**DOCSIS 3.1 OFDMA Channel Configuration 655**

Hardware Compatibility Matrix for the Cisco cBR Series Routers 655

Information about OFDMA Channel Configuration 657

    OFDMA Channels 657

    Modulation Profile 657

    OFDMA Channel Exclusion Band 658

Configure OFDMA Channel 658

    Configuring OFDMA Controller Profile 658

    Verifying OFDMA Modulation Profile Configuration 659

    Configuring OFDMA Channel 660

    Verifying OFDMA Channel Configuration 662

    Configure Exclusion / Unused Bands 663

    Verifying Exclusion / Unused Bands 664

    Override OFDMA Profile Per Channel 664

    Verifying Override Configuration 666

    Apply OFDMA Upstream To Cable Interface 667

    Determine DOCSIS 3.1 Cable Modems and the Cable Modems Using OFDMA Upstreams 667



Verifying DOCSIS 3.1 Upstream OFDMA channel bonding across DOCSIS 3.0 ATDMA channels	669
Display the OFDMA Performance Statistics	669
Feature Information for DOCSIS 3.1 OFDMA Channel Configuration	674

---

**CHAPTER 41**

<b>OFDMA OUDP Leak Detection Configuration</b>	<b>675</b>
OUDP Leakage Detection	675
Methods to Configure OUDP Leak Detection	676
Supported Line Cards	676
OUDP Leakage Detection Test Sessions	676
OUDP Leakage Detection Test Procedure	678
OUDP Parent Test Sessions	679
OUDP Child Test Sessions	679
Persistent OUDP Test Sessions	681
OUDP Late Modem Joining	682
OUDP System Boot Holdoff	683
OUDP Test Expiration	683
OUDP Test Session High Availability	683
MIB Considerations	683
EXEC Mode Command Summary	684
Global Configuration Mode Command Summary	687
Configuration Mode Command Summary	687
OUDP Burst-Profile Sub-Mode Config CLI Commands	688
Show OUDP Command Summary	689
Related Show Command Summary	690
Example: Configuration Command Mode	690
Example: EXEC Command Mode	691
Verifying the OUDP Session	691
Example: Creating a Test Session on Selected Modems Using the EXEC Mode	692
Specifications	693
Recommendations for the OFDMA Burst Testing Channel Configuration	693
Example: Channel Configuration for a Third-Party Leak Detector	693
OUDP DOCS-LEAK-DETECT MIB	694

---

<b>CHAPTER 42</b>	<b>Time and Frequency Division Multiplexing Configuration</b>	<b>701</b>
	Information About TaFDM Support	701
	Prerequisites for Configuring TaFDM Support	701
	How to Configure cBR for TaFDM Support	702
	Configuring TaFDM Modulation Profile	702
	Configuring I/O Controller for TaFDM	702
	Enhancing OFDMA Channel Throughput	703
	Enhancing SC-QAM Channel UGS Flow Performance	703
	Configuring Cable Interface-MAC Domain	703
	Configuring Service Class	704
	Excluding a Frequency Band from TaFDM	704
	Verifying TaFDM Configuration	704
	Configuration Example	704
	Feature Information for TaFDM Configuration	705

---

<b>CHAPTER 43</b>	<b>DOCSIS 3.1 Upstream Profile Selection</b>	<b>707</b>
	Hardware Compatibility Matrix for the Cisco cBR Series Routers	707
	Information about Upstream Profiles	709
	Default Data IUC	709
	Recommended Interval Usage Code (IUC)	709
	How to Configure Upstream Profiles	709
	Configuring RxMER to Bit Loading Mapping	709
	Configuring Codeword Error Threshold	710
	Downgrading to Partial Mode	712
	Configuring RxMER Downgrade	713
	Manually Configuring OFDMA Modulation Profile Downgrade	714
	Display the Cable Modem Count per Profile	716
	Feature Information for Upstream Profile Selection	717

---

<b>CHAPTER 44</b>	<b>Proactive Network Management</b>	<b>719</b>
	Hardware Compatibility Matrix for the Cisco cBR Series Routers	719
	Fast Fourier Transform	720
	Information about Proactive Network Management	726

Proactive Network Management for Supervisor High Availability, Line Card High Availability and containers	726
Proactive Network Management Using Upstream Triggered Spectrum Capture	726
Proactive Network Management Interface Index	728
Upstream Triggered Spectrum Capture Configuration Parameters	731
Upstream Triggered Spectrum Capture Configuration Objects	731
Upstream Triggered Spectrum Capture Configuration MIB Objects	732
Upstream Triggered Spectrum Capture Control Objects and MIBs	741
Upstream Triggered Spectrum Capture Status Objects and MIBs	743
Upstream Triggered Spectrum Capture Capability Objects and MIBs	743
Upstream Triggered Spectrum Capture Bulk Data Control Objects and MIBs	745
High-Split Upstream Spectrum Capture Support	762
Multiple Spectrum Acquisition Circuits on a Single Port	763
Configuring Multiple Spectrum Acquisition Circuits on a Single Port	764
Verifying the Spectrum Acquisition Circuits Configuration	764
UTSC CM-MAC for Third-Party RPD	766
Configuring the PNM MAX-HOLD UTSC Other Trigger Mode	767
Proactive Network Management MAX-HOLD trigger mode	768
Debugging the PNM feature on cBR8	769
Quick Install Guide	770
Proactive Network Management using OFDMA RxMER Probes	773
PNM RxMER Probe High Availability	774
RxMer Probe Debugging	774
Proactive Network Management using OFDMA RxPwr Probes	777
Clearing Modem on Proactive Network Management Upstream Channel RxPwr	782
Verifying the Proactive Network Management Using OFDMA RxPwr Probes	787
Troubleshooting Proactive Network Management Issues	789
Upstream External PMA	790
Feature Information for Proactive Network Management	814

---

**CHAPTER 45**
**Downstream Power Tilt 817**

Hardware Compatibility Matrix for the Cisco cBR Series Routers	817
Information about Downstream Power Tilt	819
Restrictions for Configuring Downstream Power Profile	819

How to Configure the Downstream Power Tilt	819
Configuring Downstream Power Tilt	819
Verifying Downstream Power Tilt Configuration	820
Feature Information for Downstream Power Tilt	821

**CHAPTER 46****Controller Profile Configuration 823**

Hardware Compatibility Matrix for the Cisco cBR Series Routers	823
Information about Controller Profile Configuration	825
How to Configure the Controller Profile	825
Configuring Downstream Controller Profile	825
Verifying Downstream Controller Profile Configuration	826
Configuring Upstream Controller Profile	827
Verifying Upstream Controller Profile Configuration	828
Support for RPHY GCP TLV 98.3 (BaseTargetRxPower)	829
Feature Information for Controller Profile Configuration	838

**CHAPTER 47****Voltage Thresholds for AC Power Supply Module Mode Control 839**

Hardware Compatibility Matrix for the Cisco cBR Series Routers	839
Information about Voltage Thresholds for AC PSM Mode Control	841
Overview of Voltage Thresholds for AC PSM Mode Control	841
How to Configure Voltage Thresholds for AC PSM Mode Control	841
Configuring Voltage Thresholds for AC PSM Mode Control	841
Verifying Voltage Thresholds for AC PSM Mode Control	842
Configuration Examples	842
Example: Configuring Voltage Thresholds for AC PSM Mode Control	842
Feature Information for Voltage Thresholds for AC PSM Mode Control	842

**CHAPTER 48****DOCSIS3.1 Downstream Zero Bit Loading 845**

Hardware Compatibility Matrix for the Cisco cBR Series Routers	845
Information about DOCSIS3.1 Downstream Zero Bit Loading	847
How to Configure DOCSIS3.1 Downstream Zero Bit Loading	847
Configuring Downstream Zero Bit Loading	847
Verifying Downstream Zero Bit Loading	848
Feature Information for DOCSIS3.1 Downstream Zero Bit Loading	849

---

<b>CHAPTER 49</b>	<b>Reducing Power Consumption</b>	<b>851</b>
	Finding Feature Information	851
	Hardware Compatibility Matrix for the Cisco cBR Series Routers	851
	Information About Reducing Power Consumption	853
	Restrictions for Setting Up Power-Saving Configuration	853
	Configure Reduction of Power Consumption	853
	Verifying the Power-Saving Configuration	854
	Feature Information for Reducing Power Consumption	854

---

<b>CHAPTER 50</b>	<b>Low Latency DOCSIS</b>	<b>855</b>
	Active Queue Management	855
	Aggregate Service Flow	860
	Latency Histogram	863
	Enabling Packet Classification for DOCSIS Compliance	871

---

<b>PART VI</b>	<b>Layer 2 and Layer 3 VPN Configuration</b>	<b>873</b>
----------------	--	------------

---

<b>CHAPTER 51</b>	<b>L2VPN Support over Cable</b>	<b>875</b>
	Finding Feature Information	875
	Hardware Compatibility Matrix for the Cisco cBR Series Routers	876
	Prerequisites for L2VPN Support over Cable	877
	Restrictions for L2VPN Support over Cable	877
	VPN ID Restrictions	878
	Information About L2VPN Support over Cable	878
	Point-to-Point L2VPN Forwarding Mode	879
	L2VPN Encodings in the CM Configuration File	880
	Supported L2VPN Encodings	881
	Voice-Call Support on L2VPN CM	882
	How to Configure L2VPN Support over Cable	882
	Configuring the Ethernet Network System Interface	882
	Preparing the DOCSIS Configuration File for L2VPN Support	883
	Manual Switchover Command Line Interface	883
	Verifying L2VPN Support over Cable	884

Enabling Voice-Call on a L2VPN CM	886
Verifying Dynamic Service Flows	886
Configuration Examples for L2VPN over Cable	887
Example: Specifying the Ethernet NSI Interface	887
Example: Enabling Voice Call Support on MPLS L2VPN	888
Example: Enabling Voice Call Support on 802.1q L2VPN	888
Example: Enabling Voice Call Support on CLI-based L2VPN	889
Additional References	890
Feature Information for L2VPN Support over Cable	891

**CHAPTER 52****L2VPN Over Port-Channel 893**

Information About L2VPN Over Port-Channel	893
TLS L2VPN	893
DOCSIS L2VPN	893
Benefits of L2VPN Over Port-Channel	894
Restrictions for L2VPN Over Port-Channel	894
How to Configure the L2VPN Over Port-Channel	894
Configuring the Port-Channel Uplink Port for TLS L2VPN	894
Configuring the Port-Channel Uplink Port for DOCSIS L2VPN	894
Verifying Port-Channel Configuration	894
Feature Information for L2VPN Over Port-Channel	895

**CHAPTER 53****MPLS Pseudowire for Cable L2VPN 897**

Finding Feature Information	897
Hardware Compatibility Matrix for the Cisco cBR Series Routers	898
Prerequisites for MPLS Pseudowire for Cable L2VPN	899
Restrictions for MPLS Pseudowire for Cable L2VPN	899
Information About MPLS Pseudowire for Cable L2VPN	900
How MPLS Transports Layer 2 Packets	900
Supported Ethernet Encapsulation on UNI	902
MPLS Pseudowire	902
Bundle254 Interface	902
Ingress Process	902
Egress Process	903

MPLS Pseudowire Control Plane Process	903
L2VPN Pseudowire Redundancy	903
MPLS Pseudowire Provisioning Methods	903
Static Provisioning Method for MPLS Pseudowires	904
Dynamic Provisioning Method for MPLS Pseudowires	904
Cisco-Specific L2VPN TLVs	906
How to Enable MPLS on a Cisco CMTS Router	908
Configuring an LDP Router ID	908
Configuring MPLS on a Gigabit Ethernet Interface	909
Configuring an MPLS Label Distribution Protocol	910
Enabling the Cisco CMTS Support for MPLS Pseudowire for Cable L2VPN	911
Customize MTU	912
How to Provision MPLS Pseudowires	912
Dynamic Provisioning of MPLS Pseudowires	912
Static Provisioning Method for MPLS Pseudowires	913
How to Configure L2VPN Pseudowire Redundancy	913
Configuring the Backup Pseudowire	913
Configuring Backup Delay	914
Performing Manual Switchover	916
Troubleshooting Tips	916
Configuration Examples for MPLS Pseudowire for Cable L2VPN	916
Configuration Example for Static Provisioning of MPLS Pseudowires	917
Configuration Examples for Dynamic Provisioning of MPLS Pseudowires	917
BSOD Specification-Based MPLS Pseudowire Provisioning: Example	917
Type-4 MPLS Pseudowire Provisioning Using the CM Configuration File: Example	919
Type-5 MPLS Pseudowire Provisioning Using the CM Configuration File: Example	921
Configuration Examples for L2VPN Pseudowire Redundancy	921
Example: Configuring Backup Pseudowire Peer and VC ID	921
Example: Configuring Backup Delay	922
Example: L2VPN Backup MPLS Pseudowire Provisioning Using the CM Configuration File	922
Verifying the MPLS Pseudowire Configuration	923
Additional References	926
Feature Information for MPLS Pseudowire for Cable L2VPN	927

---

**CHAPTER 54****MPLS VPN Cable Enhancements 929**

Finding Feature Information 929

Hardware Compatibility Matrix for the Cisco cBR Series Routers 929

Feature Overview 931

Benefits 933

Restrictions 934

Prerequisites 934

Other Important Information 935

Configuration Tasks 935

Creating VRFs for each VPN 935

Defining Subinterfaces on a Virtual Bundle Interface and Assigning VRFs 937

Configuring Cable Interface Bundles 938

Configuring Subinterfaces and MPLS VPNs on a Virtual Bundle Interface 938

Configuring MPLS in the P Routers in the Provider Core 938

Verifying the MPLS VPN Configuration 939

Configuration Examples 940

VRF Definition Configuration 940

Cable Bundle SubInterface Configuration 941

PE WAN Interface Configuration 942

PE BGP Configuration 942

Additional References 944

Feature Information for MPLS VPN Cable Enhancements 945

---

**CHAPTER 55****Multicast VPN and DOCSIS 3.0 Multicast QoS Support 947**

Finding Feature Information 947

Hardware Compatibility Matrix for the Cisco cBR Series Routers 948

Restrictions for the Multicast VPN and DOCSIS 3.0 Multicast QoS Support 949

Information About the Multicast VPN and DOCSIS 3.0 Multicast QoS Support 949

Enhanced Quality of Service 949

Intelligent Multicast Admission Control 950

Multicast Session Limit Support 950

Multicast Virtual Private Network 950

How to Configure the Multicast VPN and DOCSIS 3.0 Multicast QoS Support 951



Configuring a QoS Profile for a Multicast Group	951
Configuring a Multicast QoS Group	951
Configuring a Default Multicast QoS Group for VRF	953
Verifying Configuration of the Multicast VPN and DOCSIS 3.0 Multicast QoS Support	954
Configuration Examples for the Multicast VPN and DOCSIS 3.0 Multicast QoS Support	955
Example: Configuring Group QoS and Group Encryption Profiles	955
Example: Configuring a QoS Group	955
Additional References	955
Feature Information for Multicast VPN and DOCSIS3.0 Multicast QoS Support	957

**CHAPTER 56****EtherChannel for the Cisco CMTS 959**

Hardware Compatibility Matrix for the Cisco cBR Series Routers	960
Restrictions for EtherChannel on the Cisco CMTS	961
Information About EtherChannel on the Cisco CMTS	961
Introduction to EtherChannel on the Cisco CMTS	961
Cisco Ten Gigabit EtherChannel on the Cisco cBR Series Routers	962
How to Configure EtherChannel on the Cisco CMTS	962
Configuring Ten Gigabit EtherChannel on the Cisco CMTS	962
Troubleshooting Tips	964
What to Do Next	964
Verifying EtherChannel on the Cisco CMTS	964
Configuration Examples for EtherChannel on the Cisco CMTS	965
Additional References	966
Feature Information for EtherChannel on Cisco CMTS	967

**CHAPTER 57****Flow-Based per Port-Channel Load Balancing 969**

Hardware Compatibility Matrix for the Cisco cBR Series Routers	969
Restrictions for Flow-Based per Port-Channel Load Balancing	970
Information About Flow-Based per Port-Channel Load Balancing	971
Flow-Based Load Balancing	971
Buckets for Flow-Based Load Balancing	971
Load Balancing on Port Channels	971
How to Enable Flow-Based per Port-Channel Load Balancing	973
Configuring Load Balancing on a Port Channel	973

Verifying Load Balancing Configuration on a Ten GEC Interface 974

Configuration Examples for Flow-Based per Port-Channel Load Balancing 976

    Example: Flow-Based Load Balancing 976

Additional References 977

Feature Information for Flow-Based per Port-Channel Load Balancing 977

---

**CHAPTER 58**

**MPLS QoS via TLV for non-L2VPN Service Flow 979**

Hardware Compatibility Matrix for the Cisco cBR Series Routers 979

Restrictions for MPLS QoS via TLV for non-L2VPN Service Flow 980

Information About MPLS QoS via TLV for non-L2VPN Service Flow 981

Configuring MPLS QoS via TLV for non-L2VPN Service Flow 981

    Traffic Class for MPLS Imposition Packets 981

    Traffic Classification for MPLS Disposition Packets 981

    Using Vendor-Specific TLVs with AToM L2VPN and MPLS L3VPN 982

Configuration Examples 982

    Example: Upstream Service Flow Marking TLV 982

    Example: Downstream Packet Classification TLV 983

    Example: MPLS QoS Configuration File 983

Additional References 986

Feature Information for MPLS QoS via TLV for non-L2VPN Service Flow 986

---

**CHAPTER 59**

**IPsec Security Support 987**

Finding Feature Information 987

Hardware Compatibility Matrix for the Cisco cBR Series Routers 987

IPsec Security Support 989

IPsec Security Limitations 989

Configuring IPsec Security 989

Configuring Transform Sets for IKEv2 991

Feature Information for IPsec Security Support 992

---

**PART VII**

**Layer 3 Configuration 995**

---

**CHAPTER 60**

**DHCP, ToD, and TFTP Services for CMTS Routers 997**

Prerequisites for DHCP, ToD, and TFTP Services 997

Restrictions for DHCP, ToD, and TFTP Services	997
Information About DHCP, ToD, and TFTP Services	998
Feature Overview	998
External DHCP Servers	998
Cable Source Verify Feature	998
Smart Relay Feature	999
GIADDR Field	1000
DHCP Relay Agent Sub-option	1000
Time-of-Day Server	1000
TFTP Server	1002
Sniff out boot file name from DHCP process per CM	1002
Benefits	1003
How to Configure ToD, and TFTP Services	1003
Configuring Time-of-Day Service	1003
Enabling Time-of-Day Service	1003
Disabling Time-of-Day Service	1004
Configuring TFTP Service	1005
Optimizing the Use of an External DHCP Server	1008
Configuring Cable Source Verify Option	1008
Configuring Prefix-based Source Address Verification	1010
Configuring Optional DHCP Parameters	1011
How to Configure ToD, and TFTP Services	1014
Configuration Examples	1014
ToD Server Example	1014
TFTP Server Example	1014
Additional References	1015
Feature Information for the DHCP, ToD, and TFTP Services for the CMTS Routers	1015

**CHAPTER 61****Virtual Interface Bundling 1017**

Hardware Compatibility Matrix for the Cisco cBR Series Routers	1017
Information About Virtual Interface Bundling	1018
Overview of Virtual Interface Bundling	1019
Guidelines for Virtual Interface Bundling	1020
Virtual Interface Bundle-aware and Bundle-unaware Support	1020

Configuring Virtual Interface Bundling	1021
Verifying the Virtual Interface Bundling Configuration	1023
Additional References	1025
Feature Information for Virtual Interface Bundling	1026

**CHAPTER 62****IPv6 on Cable 1027**

Hardware Compatibility Matrix for the Cisco cBR Series Routers	1028
Restrictions for IPv6 on Cable	1029
Capability Restrictions	1029
Multicast Restrictions	1029
QoS Restrictions	1030
Information About IPv6 on Cable	1030
Features Supported	1030
Overview of the DOCSIS 3.0 Network Model Supporting IPv6	1031
Overview of Cable Modem IPv6 Address Provisioning	1032
Overview of IPv6 Dual Stack CPE Support on the CMTS	1034
Overview of IPv6 over Subinterfaces	1034
Overview of High Availability on IPv6	1034
DOCSIS PRE HA	1034
DOCSIS Line Card HA	1034
Dynamic Channel Change	1035
Overview of IPv6 VPN over MPLS	1035
Cable Monitor	1036
Overview of IPv6 CPE Router Support on the Cisco CMTS	1036
Support for IPv6 Prefix Stability on the CMTS	1037
Configurable DHCPv6 Relay Address	1037
Support for Multiple IAPDs in a Single Advertise	1038
IPv6 Neighbor Discovery Gleaning	1039
How to Configure IPv6 on Cable	1039
Configuring IPv6 Switching Services	1039
Implementing IPv6 Addressing and Basic Connectivity for Cable Interfaces and Bundles	1041
Configuring the Cable Virtual Bundle Interface	1041
Configuring the IP Provisioning Mode and Bundle on the Cable Interface	1042
Enabling MDD with Pre-Registration DSID	1044

Configuring IPv6 Cable Filter Groups	1044
Configuring IPv6 Cable Filter Groups	1044
Cable Filter Groups and the DOCSIS Subscriber Management MIB	1044
Troubleshooting Tips	1049
Configuring IPv6 Domain Name Service	1049
Configuring IPv6 Source Verification	1051
Configuring IPv6 VPN over MPLS	1052
Configuring DHCPv6 Relay Agent	1052
Configuring IPv6 Source Address and Link Address	1053
Configurable DOCSIS CMTS Capabilities DHCPv6 Field	1053
Disabling IPv6 ND Gleaning	1054
How to Verify IPv6 Dual Stack CPE Support	1054
Examples	1055
Configuration Examples for IPv6 on Cable	1056
Example: IPv6 over Subinterfaces	1056
Example: Basic IPv6 Cable Filter Groups	1056
Example: Complete Cable Configuration with IPv6	1057
Example: BGP Configuration for 6VPE	1065
Example: Subinterface Configuration for 6VPE	1065
Example: Cable Interface Bundling	1066
Example: VRF Configuration for 6VPE	1066
Verifying IPv6 on Cable	1066
Verifying IPv6 VRF Configuration	1066
Verifying IPv6 BGP Status	1067
Verifying MPLS Forwarding Table	1067
Verifying IPv6 Cable Modem and its Host State	1067
Verifying Multiple IAPDs in a Single Advertise	1068
Supported MIBs	1068
Additional References	1069
Feature Information for IPv6 on Cable	1069

**CHAPTER 63****Cable DHCP Leasequery 1071**

Hardware Compatibility Matrix for the Cisco cBR Series Routers	1071
Prerequisites for Cable DHCP Leasequery	1073

Restrictions for Cable DHCP Leasequery	1073
Information About Cable DHCP Leasequery	1073
DHCP MAC Address Exclusion List	1074
Unitary DHCPv6 Leasequery	1074
How to Configure Filtering of Cable DHCP Leasequery Requests	1075
Enabling DHCP Leasequery Filtering on Downstreams	1075
Enabling DHCP Leasequery Filtering on Upstreams	1076
Configuring Unitary DHCPv6 Leasequery Filtering	1076
Enabling DHCPv6 Leasequery Filtering on Downstreams	1078
Configuration Examples for Filtering of DHCP Leasequery	1079
Example: DHCP Leasequery Filtering	1079
Example: Unitary DHCPv6 Leasequery Filtering	1079
Additional References	1080
Feature Information for Cable DHCP Leasequery	1080

**CHAPTER 64****DHCPv6 Bulk-Lease query 1081**

Hardware Compatibility Matrix for the Cisco cBR Series Routers	1081
Information About DHCPv6 Bulk-Lease Query	1083
How to Configure DHCPv6 Bulk-Lease Query	1083
Debugging DHCPv6 Bulk-Lease Query	1084
Feature Information for DHCPv6 Bulk-Lease query	1084

**CHAPTER 65****Layer 3 CPE Mobility 1085**

Hardware Compatibility Matrix for the Cisco cBR Series Routers	1085
Prerequisites for Layer 3 CPE Mobility	1086
Restrictions for Layer 3 CPE Mobility	1087
Information About Layer 3 CPE Mobility	1087
Benefits of Layer 3 CPE Mobility	1088
How to Configure Layer 3 Mobility	1088
Configuring CPE Mobility	1088
Configure Source-Based Rate Limit (SBRL) for L3-mobility	1089
Disabling CPE Mobility	1090
Verifying Layer 3 Mobility Configuration	1091
Configuration Examples for Layer 3 Mobility	1091

Example: Configuring CPE Layer 3 Mobility	1091
Example: Configuring SBRL for L3-mobility	1092
Additional References	1092
Feature Information for Layer 3 CPE Mobility	1092

**CHAPTER 66****DOCSIS 3.0 Multicast Support 1095**

Hardware Compatibility Matrix for the Cisco cBR Series Routers	1095
Prerequisites for the DOCSIS 3.0 Multicast Support	1096
Restrictions for the DOCSIS 3.0 Multicast Support	1097
Information About the DOCSIS 3.0 Multicast Support	1097
Multicast DSID Forwarding	1097
Multicast Forwarding on Bonded CM	1098
Static TLV Forwarding	1099
Explicit Tracking	1099
Multicast Quality of Service Enhancement	1099
Multicast Secondary Bonding Group	1100
Load Balancing	1100
Multicast DSID Forwarding Disabled Mode	1100
MDF1 Support for DOCSIS 2.0 Hybrid Cable Modems	1101
DSG Disablement for Hybrid STBs	1101
Benefits of MDF1 Support	1101
Dynamic Multicast Replication Sessions	1101
Cache Multicast Replication Sessions	1102
How to Configure the DOCSIS 3.0 Multicast Support	1102
Configuring Basic Multicast Forwarding	1102
Configuring Querier's Robustness Variable	1103
Configuring Querier Robustness Variable	1104
Configuring Multicast DSID Forwarding	1104
Configuring Explicit Tracking	1104
Configuring Multicast QoS	1104
Selecting a Forwarding Interface Based on Service Flow Attribute	1106
Configuring Multicast DSID Forwarding Disabled Mode	1109
Configuring Multicast Replication Session Globally	1110
Configuring Multicast Replication Sessions on Forwarding Interface	1110

Clearing Multicast Replication Cache	1111
How to Monitor the DOCSIS 3.0 Multicast Support	1111
Verifying the Basic Multicast Forwarding	1111
Verifying the Multicast DSID Forwarding	1112
Verifying the Explicit Tracking Feature	1113
Verifying the Multicast QoS Feature	1113
Verifying the Service Flow Attributes	1114
Verifying the Multicast Group Classifiers	1114
Troubleshooting Tips	1114
Viewing Current Cache	1114
Configuration Examples for DOCSIS 3.0 Multicast Support	1116
Example: Configuring Basic Multicast Forwarding	1116
Example: Configuring Multicast QoS	1116
Example: Configuring Forwarding Interface Selection Based on Service Flow Attribute	1117
Example: Configuring Multicast Replication Session	1117
Additional References	1117
Feature Information for DOCSIS 3.0 Multicast Support	1119

---

**CHAPTER 67**
**IPv6 Segment Routing on Cisco cBR 1121**

Hardware Compatibility Matrix for the Cisco cBR Series Routers	1121
Information about IPv6 Segment Routing	1123
Restriction for Configuring IPv6 Segment Routing	1123
How to Configure IPv6 Segment Routing	1123
Configuring IPv6 Segment Routing on cBR	1123
Verifying IPv6 Segment Routing Configuration	1123
Configure Multiple IPv6 Addresses for Segment Routing	1124
Verifying IPv6 Segment Routing Configuration on Multiple IPv6 Addresses	1124
Disabling Prefix SID	1124
Verifying whether Prefix SID is Disabled	1125
Disabling SRv6 for a Prefix-SID	1125
Verifying whether SRv6 is Disabled and Prefix SID Removed	1125
Configuration Examples	1125
Example: Configuring IPv6 Segment Routing on Cisco cBR	1125
Example: Configure Multiple IPv6 Addresses for SRv6	1126



Example: Disabling Prefix SID	1126
Example: Disabling SR with an Active Prefix SID	1126
Feature Information for IPv6 Segment Routing	1126

---

**PART VIII****IP Access Control Lists 1127**

---

**CHAPTER 68****IP Access Control Lists 1129**

Hardware Compatibility Matrix for the Cisco cBR Series Routers	1129
Information About IP Access Lists	1131
Benefits of IP Access Lists	1131
Border Routers and Firewall Routers Should Use Access Lists	1131
Definition of an Access List	1132
Access List Rules	1133
Helpful Hints for Creating IP Access Lists	1133
Named or Numbered Access Lists	1134
Standard or Extended Access Lists	1134
IP Packet Fields You Can Filter to Control Access	1135
Wildcard Mask for Addresses in an Access List	1136
Access List Sequence Numbers	1137
Access List Logging	1137
Alternative to Access List Logging	1137
Additional IP Access List Features	1138
Where to Apply an Access List	1138
Additional References	1138
Feature Information for IP Access Lists	1139

---

**CHAPTER 69****Creating an IP Access List and Applying It to an Interface 1141**

Hardware Compatibility Matrix for the Cisco cBR Series Routers	1142
Information About Creating an IP Access List and Applying It to an Interface	1143
Helpful Hints for Creating IP Access Lists	1143
Access List Remarks	1144
Additional IP Access List Features	1144
How to Create an IP Access List and Apply It to an Interface	1144
Creating a Standard Access List to Filter on Source Address	1144

Creating a Named Access List to Filter on Source Address	1145
Creating a Numbered Access List to Filter on Source Address	1147
Creating an Extended Access List	1148
Creating a Named Extended Access List	1148
Creating a Numbered Extended Access List	1150
Applying an Access List to an Interface	1152
Configuration Examples for Creating an IP Access List and Applying It to a Physical Interface	1153
Example: Filtering on Host Source Address	1153
Example: Filtering on Subnet Source Address	1154
Example: Filtering on Source and Destination Addresses and IP Protocols	1154
Example: Filtering on Source Addresses Using a Numbered Access List	1154
Example: Preventing Telnet Access to a Subnet	1155
Example: Filtering on TCP and ICMP Using Port Numbers	1155
Example: Allowing SMTP E-mail and Established TCP Connections	1155
Example: Preventing Access to the Web by Filtering on Port Name	1156
Example: Filtering on Source Address and Logging the Packets	1156
Example: Limiting Debug Output	1156
Additional References Creating an IP Access List and Applying It to an Interface	1157
Feature Information Creating an IP Access List and Applying It to an Interface	1158
<hr/>	
<b>CHAPTER 70</b>	<b>Creating an IP Access List to Filter IP Options, TCP Flags, Noncontiguous Ports</b>
	1159
Hardware Compatibility Matrix for the Cisco cBR Series Routers	1159
Prerequisites for Creating an IP Access List to Filter IP Options TCP Flags Noncontiguous Ports	1161
Information About Creating an IP Access List to Filter IP Options, TCP Flags, Noncontiguous Ports	1161
IP Options	1161
Benefits of Filtering IP Options	1161
Benefits of Filtering on TCP Flags	1162
TCP Flags	1162
Benefits of Using the Named ACL Support for Noncontiguous Ports on an Access Control Entry Feature	1163
How Filtering on TTL Value Works	1163
Benefits of Filtering on TTL Value	1164
How to Create an IP Access List to Filter IP Options TCP Flags Noncontiguous Ports	1164

Filtering Packets That Contain IP Options	1164
What to Do Next	1166
Filtering Packets That Contain TCP Flags	1166
Configuring an Access Control Entry with Noncontiguous Ports	1168
Consolidating Access List Entries with Noncontiguous Ports into One Access List Entry	1169
What To Do Next	1171
Filtering Packets Based on TTL Value	1171
Enabling Control Plane Policing to Filter on TTL Values 0 and 1	1173
Configuration Examples for Filtering IP Options, TCP Flags, Noncontiguous Ports	1175
Example: Filtering Packets That Contain IP Options	1175
Example: Filtering Packets That Contain TCP Flags	1176
Example: Creating an Access List Entry with Noncontiguous Ports	1176
Example: Consolidating Some Existing Access List Entries into One Access List Entry with Noncontiguous Ports	1176
Example: Filtering on TTL Value	1177
Example: Control Plane Policing to Filter on TTL Values 0 and 1	1177
Additional References	1178
Feature Information for Creating an IP Access List to Filter IP Options, TCP Flags, Noncontiguous Ports, or TTL Values	1179

---

**CHAPTER 71**
**Refining an IP Access List 1181**

Hardware Compatibility Matrix for the Cisco cBR Series Routers	1181
Information About Refining an IP Access List	1183
Access List Sequence Numbers	1183
Benefits of Access List Sequence Numbers	1183
Sequence Numbering Behavior	1183
Benefits of Time Ranges	1184
Benefits Filtering Noninitial Fragments of Packets	1184
Access List Processing of Fragments	1185
How to Refine an IP Access List	1186
Revising an Access List Using Sequence Numbers	1186
Restricting an Access List Entry to a Time of Day or Week	1189
What to Do Next	1190
Configuration Examples for Refining an IP Access List	1191

Example Resequencing Entries in an Access List	1191
Example Adding an Entry with a Sequence Number	1191
Example Adding an Entry with No Sequence Number	1192
Example Time Ranges Applied to IP Access List Entries	1192
Example Filtering IP Packet Fragments	1192
Additional References	1193
Feature Information for Refining an IP Access List	1194

**CHAPTER 72****IP Named Access Control Lists 1195**

Hardware Compatibility Matrix for the Cisco cBR Series Routers	1195
Information About IP Named Access Control Lists	1197
Definition of an Access List	1197
Named or Numbered Access Lists	1197
Benefits of IP Access Lists	1198
Access List Rules	1198
Helpful Hints for Creating IP Access Lists	1199
Where to Apply an Access List	1200
How to Configure IP Named Access Control Lists	1201
Creating an IP Named Access List	1201
Applying an Access List to an Interface	1203
Additional References for IP Named Access Control Lists	1203
Feature Information for IP Named Access Control Lists	1204

**CHAPTER 73****IPv4 ACL Chaining Support 1205**

Hardware Compatibility Matrix for the Cisco cBR Series Routers	1205
Restrictions for IPv4 ACL Chaining Support	1207
Information About IPv4 ACL Chaining Support	1207
ACL Chaining Overview	1207
IPv4 ACL Chaining Support	1207
How to Configure IPv4 ACL Chaining Support	1208
Configuring an Interface to Accept Common ACL	1208
Configuration Examples for IPv4 ACL Chaining Support	1208
Example: Configuring an Interface to Accept a Common ACL	1209
Additional References for IPv4 ACL Chaining Support	1209

Feature Information for IPv4 ACL Chaining Support 1210

---

**CHAPTER 74**

**IPv6 ACL Chaining with a Common ACL 1211**

Hardware Compatibility Matrix for the Cisco cBR Series Routers 1211

Information About IPv6 ACL Chaining with a Common ACL 1213

ACL Chaining Overview 1213

IPv6 ACL Chaining with a Common ACL 1213

How to Configure IPv6 ACL Chaining with a Common ACL 1213

Configuring IPv6 ACL to an Interface 1214

Configuration Examples for IPv6 ACL Chaining with a Common ACL 1215

Example: Configuring an Interface to Accept a Common ACL 1215

Additional References for IPv6 ACL Chaining with a Common ACL 1216

Feature Information for IPv6 ACL Chaining with a Common ACL 1217

---

**CHAPTER 75**

**Commented IP Access List Entries 1219**

Hardware Compatibility Matrix for the Cisco cBR Series Routers 1219

Information About Commented IP Access List Entries 1221

Benefits of IP Access Lists 1221

Access List Remarks 1221

How to Configure Commented IP Access List Entries 1222

Writing Remarks in a Named or Numbered Access List 1222

Additional References for Commented IP Access List Entries 1223

Feature Information for Commented IP Access List Entries 1223

---

**CHAPTER 76**

**Standard IP Access List Logging 1225**

Hardware Compatibility Matrix for the Cisco cBR Series Routers 1225

Restrictions for Standard IP Access List Logging 1226

Information About Standard IP Access List Logging 1227

Standard IP Access List Logging 1227

How to Configure Standard IP Access List Logging 1227

Creating a Standard IP Access List Using Numbers 1227

Creating a Standard IP Access List Using Names 1228

Configuration Examples for Standard IP Access List Logging 1229

Example: Limiting Debug Output 1229

Additional References for Standard IP Access List Logging	1230
Feature Information for Standard IP Access List Logging	1230

---

**CHAPTER 77****IP Access List Entry Sequence Numbering 1231**

Hardware Compatibility Matrix for the Cisco cBR Series Routers	1231
Restrictions for IP Access List Entry Sequence Numbering	1232
Information About IP Access List Entry Sequence Numbering	1233
Purpose of IP Access Lists	1233
How an IP Access List Works	1233
IP Access List Process and Rules	1233
Helpful Hints for Creating IP Access Lists	1234
Source and Destination Addresses	1235
Wildcard Mask and Implicit Wildcard Mask	1235
Transport Layer Information	1236
Benefits IP Access List Entry Sequence Numbering	1236
Sequence Numbering Behavior	1236
How to Use Sequence Numbers in an IP Access List	1237
Sequencing Access-List Entries and Revising the Access List	1237
Configuration Examples for IP Access List Entry Sequence Numbering	1240
Example: Resequencing Entries in an Access List	1240
Example: Adding Entries with Sequence Numbers	1241
Example: Entry Without Sequence Number	1241
Additional References	1242
Feature Information for IP Access List Entry Sequence Numbering	1242

---

**CHAPTER 78****ACL IP Options Selective Drop 1243**

Hardware Compatibility Matrix for the Cisco cBR Series Routers	1243
Restrictions for ACL IP Options Selective Drop	1245
Information About ACL IP Options Selective Drop	1245
Using ACL IP Options Selective Drop	1245
Benefits of Using ACL IP Options Selective Drop	1245
How to Configure ACL IP Options Selective Drop	1245
Configuring ACL IP Options Selective Drop	1245
Configuration Examples for ACL IP Options Selective Drop	1246

Example Configuring ACL IP Options Selective Drop	1246
Example Verifying ACL IP Options Selective Drop	1246
Additional References for IP Access List Entry Sequence Numbering	1247
Feature Information for ACL IP Options Selective Drop	1248

**CHAPTER 79****ACL Syslog Correlation 1249**

Hardware Compatibility Matrix for the Cisco cBR Series Routers	1249
Prerequisites for ACL Syslog Correlation	1251
Information About ACL Syslog Correlation	1251
ACL Syslog Correlation Tags	1251
ACE Syslog Messages	1251
How to Configure ACL Syslog Correlation	1252
Enabling Hash Value Generation on a Device	1252
Disabling Hash Value Generation on a Device	1253
Configuring ACL Syslog Correlation Using a User-Defined Cookie	1254
Configuring ACL Syslog Correlation Using a Hash Value	1255
Changing the ACL Syslog Correlation Tag Value	1257
Troubleshooting Tips	1258
Configuration Examples for ACL Syslog Correlation	1258
Example: Configuring ACL Syslog Correlation Using a User-Defined Cookie	1258
Example: Configuring ACL Syslog Correlation using a Hash Value	1259
Example: Changing the ACL Syslog Correlation Tag Value	1259
Additional References for IPv6 IOS Firewall	1260
Feature Information for ACL Syslog Correlation	1260

**CHAPTER 80****IPv6 Access Control Lists 1263**

Hardware Compatibility Matrix for the Cisco cBR Series Routers	1263
Information About IPv6 Access Control Lists	1265
Access Control Lists for IPv6 Traffic Filtering	1265
IPv6 Packet Inspection	1265
Access Class Filtering in IPv6	1265
How to Configure IPv6 Access Control Lists	1265
Configuring IPv6 Traffic Filtering	1265
Creating and Configuring an IPv6 ACL for Traffic Filtering	1265

	Applying the IPv6 ACL to an Interface	1267
	Controlling Access to a vty	1268
	Creating an IPv6 ACL to Provide Access Class Filtering	1268
	Applying an IPv6 ACL to the Virtual Terminal Line	1269
	Configuration Examples for IPv6 Access Control Lists	1270
	Example: Verifying IPv6 ACL Configuration	1270
	Example: Creating and Applying an IPv6 ACL	1270
	Example: Controlling Access to a vty	1271
	Additional References	1271
	Feature Information for IPv6 Access Control Lists	1271
<hr/>		
<b>CHAPTER 81</b>	<b>IPv6 Template ACL</b>	<b>1273</b>
	Hardware Compatibility Matrix for the Cisco cBR Series Routers	1274
	Information About IPv6 ACL—Template ACL	1275
	IPv6 Template ACL	1275
	How to Enable IPv6 ACL—Template ACL	1275
	Enabling IPv6 Template Processing	1275
	Configuration Examples for IPv6 ACL—Template ACL	1276
	Example: IPv6 Template ACL Processing	1276
	Additional References	1277
	Feature Information for IPv6 Template ACL	1278
<hr/>		
<b>CHAPTER 82</b>	<b>IPv6 ACL Extensions for Hop by Hop Filtering</b>	<b>1279</b>
	Hardware Compatibility Matrix for the Cisco cBR Series Routers	1279
	Information About IPv6 ACL Extensions for Hop by Hop Filtering	1281
	ACLs and Traffic Forwarding	1281
	How to Configure IPv6 ACL Extensions for Hop by Hop Filtering	1281
	Configuring IPv6 ACL Extensions for Hop by Hop Filtering	1281
	Configuration Example for IPv6 ACL Extensions for Hop by Hop Filtering	1282
	Example: IPv6 ACL Extensions for Hop by Hop Filtering	1282
	Additional References	1283
	Feature Information for IPv6 ACL Extensions for Hop by Hop Filtering	1284
<hr/>		
<b>PART IX</b>	<b>Application—Voice and Video Configuration</b>	<b>1285</b>



<b>CHAPTER 83</b>	<b>Unique Device Identifier Retrieval</b>	<b>1287</b>
	Hardware Compatibility Matrix for the Cisco cBR Series Routers	1287
	Unique Device Identifier Overview	1289
	Benefits of the Unique Device Identifier Retrieval Feature	1289
	Retrieving the Unique Device Identifier	1289
	Troubleshooting Tips	1292
	Additional References	1293
	Feature Information for Unique Device Identifier Retrieval	1293
<b>CHAPTER 84</b>	<b>Advanced-Mode DOCSIS Set-Top Gateway 1.2 for the Cisco CMTS Routers</b>	<b>1295</b>
	Hardware Compatibility Matrix for the Cisco cBR Series Routers	1296
	Prerequisites for Advanced-Mode DSG Issue 1.2	1297
	Restrictions for Advanced-Mode DSG Issue 1.2	1297
	DSG Configuration File Transfer Operations	1297
	Multicast Configuration Restrictions	1297
	NAT for DSG Unicast-only Mapping	1297
	PIM and SSM for Multicast	1298
	Subinterfaces	1298
	Information About Advanced-Mode DSG Issue 1.2	1298
	DSG 1.2 Clients and Agents	1298
	FQDN Support	1298
	DSG Name Process and DNS Query	1299
	A-DSG Forwarding on the Primary Channel	1299
	DOCSIS 3.0 DSG MDF Support	1299
	Source Specific Multicast Mapping	1300
	How to Configure Advanced-Mode DSG Issue 1.2	1300
	Configuring the Default Multicast Quality of Service	1300
	Configuring DSG OPS Under MAC Domain Profile	1301
	Configuring Global Tunnel Group Settings for Advanced-Mode DSG 1.2	1303
	Global A-DSG 1.2 Tunnel Settings	1303
	Adding DSG Tunnel Group to a Subinterface	1305
	Configuring the DSG Client Settings for Advanced-Mode DSG 1.2	1305
	Configuring Downstream DSG 1.2 Settings for Advanced-Mode DSG 1.2	1307

Configuring IP Multicast Operations	1308
Enabling DNS Query and DSG Name Process	1309
Configuring NAT to Support Unicast Messaging	1310
Gatekeeper Cache Size	1312
Configuring WAN Interfaces for Multicast Operations	1313
Configuring a Standard IP Access List for Packet Filtering	1313
Configuring a Standard IP Access List for Multicast Group Filtering	1315
Disabling A-DSG Forwarding on the Primary Channel	1317
How to Monitor and Debug the Advanced-mode DOCSIS Set-Top Gateway Feature	1317
Displaying Global Configurations for Advanced-Mode DSG 1.2	1317
show cable dsg cfr	1317
show cable dsg host	1318
show cable dsg tunnel	1318
show cable dsg tg	1318
show running-config interface	1318
show cable dsg static-group bundle	1319
Displaying Interface-level Configurations for Advanced-Mode DSG 1.2	1319
show cable dsg tunnel interfaces	1319
show interfaces cable dsg downstream	1319
show interfaces cable dsg downstream dcd	1319
show interfaces cable dsg downstream tg	1319
show interfaces cable dsg downstream tunnel	1319
Debugging Advanced-Mode DSG	1320
Configuration Examples for Advanced-Mode DSG	1320
Example: Enabling DNS Query	1322
Example: Disabling A-DSG Forwarding on the Primary Channel	1322
Additional References	1323
Feature Information for Advanced-Mode DSG 1.2 for the Cisco CMTS Routers	1323

---

**CHAPTER 85**

<b>Cisco Network Registrar for the Cisco CMTS Routers</b>	<b>1325</b>
Hardware Compatibility Matrix for the Cisco cBR Series Routers	1326
Servers Required on the HFC Network	1327
Cisco Network Registrar Description	1328
Overview of DHCP Using CNR	1328

How Cisco Converged Broadband Routers and Cable Modems Work	1329
DHCP Fields and Options for Cable Modems	1330
Cisco Network Registrar Sample Configuration	1331
Cable Modem DHCP Response Fields	1333
DOCSIS DHCP Fields	1333
DHCP Relay Option (DOCSIS Option 82)	1334
Overview of Scripts	1334
Two-way Cable Modem Scripts	1334
Telco Return Cable Modem Scripts	1334
Placement of Scripts	1335
Windows NT	1335
Solaris	1335
Activating Scripts in Cisco Network Registrar	1335
Configuring the Cisco CMTS Routers to Use Scripts	1335
Configuring the System Default Policy	1336
Cable Modems	1336
PCs	1336
Creating Selection Tag Scopes	1336
General	1336
Telco Return for the Cisco cBR-8 Router	1337
Creating Network Scopes	1337
Creating Policies for Class of Service or for Upgrading Cable Modem Cisco IOS Images	1338
CNR Steps to Support Subinterfaces	1338
Additional References	1339

---

**PART X**
**PacketCable and PacketCable Multimedia Configuration** 1341

---

**CHAPTER 86**
**PacketCable and PacketCable Multimedia** 1343

Finding Feature Information	1343
Hardware Compatibility Matrix for the Cisco cBR Series Routers	1344
Restrictions for PacketCable Operations	1345
Information About PacketCable Operations	1345
Feature Overview	1345
Emergency 911 Features	1346

PacketCable Emergency 911 Cable Interface Line Card Prioritization	1346
PacketCable Emergency 911 Services Listing and History	1346
PacketCable Network Components	1346
Dynamic Quality of Service	1347
Two-Stage Resource Reservation Process	1348
Making a Call Using DQoS	1348
DQoSLite Based IPv6 Voice Support	1349
Dynamic Service Transaction ID Support	1349
PacketCable Subscriber ID Support	1350
Benefits	1350
How to Configure PacketCable Operations	1351
Enabling PacketCable Operation	1351
Disabling PacketCable Operation	1352
Configuring PacketCable Operation	1353
Enabling Both PacketCable and Non-PacketCable UGS Service Flows	1354
Enabling PacketCable Subscriber ID Support	1355
Configuring RADIUS Accounting for RKS Servers	1356
PacketCable Client Accept Timeout	1358
Configuration Examples for PacketCable	1359
Example: Typical PacketCable Configuration	1359
Verifying PacketCable Operations	1362
Verifying Emergency 911 Calls	1363
Information About PacketCable Multimedia Operations	1366
PCMM Overview	1366
PCMM Enhancements over PacketCable 1.x	1367
PCMM and High Availability Features on the Cisco CMTS Router	1367
PCMM Gates	1368
PCMM Gate Overview and PCMM Dynamic Quality of Service	1368
PCMM Persistent Gate	1368
PCMM High Priority Calls	1368
PCMM Interfaces	1369
PCMM to COPS Interface	1369
PCMM and Distributed Cable Interface Line Cards	1369
PCMM Unicast and Multicast	1369

PCMM Multicast Session Range	1370
How to Configure PCMM Operations	1370
Enabling PCMM Operations on the Cisco CMTS Router	1370
Configuring a PCMM Multicast Session Range	1371
Configuration Examples for PacketCable Multimedia	1372
Example: Enabling PCMM Operations on the Cisco CMTS Router	1372
Example: Enabling a Multicast Session Range on the Cisco CMTS Router	1373
Verifying PCMM Operations	1373
High Availability Stateful Switchover (SSO) for PacketCable and PacketCable MultiMedia	1375
PacketCable and PCMM with Admission Control	1375
Voice MGPI Support	1375
Voice Support Over DOCSIS 3.0 E-MTAs	1376
PacketCable and PCMM Call Trace	1376
Verifying PacketCable and PCMM Statistics	1376
Additional References	1378
Feature Information for PacketCable and PacketCable Multimedia	1379

**CHAPTER 87****COPS Engine Operation 1381**

Finding Feature Information	1381
Hardware Compatibility Matrix for the Cisco cBR Series Routers	1381
Prerequisites for the COPS Engine on the Cisco CMTS Routers	1383
Restrictions for the COPS Engine on the Cisco CMTS	1383
Information About the COPS Engine on the Cisco CMTS	1383
How to Configure the COPS Engine on the Cisco CMTS	1383
Configuring COPS TCP and DSCP Marking	1383
Configuring COPS TCP Window Size	1385
Configuring Access Control List Support for COPS Engine	1386
Restricting RSVP Policy to Specific Access Control Lists	1386
Displaying and Verifying COPS Engine Configuration on the Cisco CMTS	1387
Show Commands for COPS Engine Information	1388
Displaying COPS Servers on the Network	1388
Displaying COPS Policy Information on the Network	1388
Displaying Access Lists for COPS	1388
COPS Engine Configuration Examples for Cable	1388

Example: COPS Server Specified 1389  
 Example: COPS Server Display 1389  
 Additional References 1389  
 Feature Information for COPS Engine Operation 1390

---

**PART XI**

**Quality of Services Configuration 1393**

---

**CHAPTER 88**

**Dynamic Bandwidth Sharing 1395**

Hardware Compatibility Matrix for the Cisco cBR Series Routers 1395  
 Information About Dynamic Bandwidth Sharing 1397  
 How to Configure Dynamic Bandwidth Sharing 1397  
     Configuring DBS for a Wideband Cable Interface 1397  
     Configuring DBS for an Integrated Cable Interface 1398  
 Verifying the Dynamic Bandwidth Sharing Configuration 1398  
 Additional References 1401  
 Feature Information for Dynamic Bandwidth Sharing 1402

---

**CHAPTER 89**

**Modular Quality of Service Command-Line Interface QoS 1403**

Finding Feature Information 1403  
 Hardware Compatibility Matrix for the Cisco cBR Series Routers 1403  
 Restrictions for Applying QoS Features Using the MQC 1405  
 About 1405  
     The MQC Structure 1405  
     Elements of a Traffic Class 1405  
     Elements of a Traffic Policy 1407  
     Nested Traffic Classes 1409  
     match-all and match-any Keywords of the class-map Command 1409  
     input and output Keywords of the service-policy Command 1410  
     Benefits of Applying QoS Features Using the MQC 1410  
 How to Apply QoS Features Using the MQC 1410  
     Creating a Traffic Class 1410  
     Creating a Traffic Policy 1412  
     Attaching a Traffic Policy to an Interface Using the MQC 1413  
     Verifying the Traffic Class and Traffic Policy Information 1414

Configuration Examples for Applying QoS Features Using the MQC	1415
Creating a Traffic Class	1415
Creating a Policy Map	1415
Example: Attaching a Traffic Policy to an Interface	1415
Using the match not Command	1416
Configuring a Default Traffic Class	1416
How Commands "class-map match-any" and "class-map match-all" Differ	1416
Establishing Traffic Class as a Match Criterion (Nested Traffic Classes)	1417
Example: Nested Traffic Class for Maintenance	1417
Example: Nested Traffic Class to Combine match-any and match-all Characteristics in One Traffic Class	1418
Example: Traffic Policy as a QoS Policy (Hierarchical Traffic Policies)	1418
How to Configure Input MQC on the Port-Channel Interfaces	1419
Creating a Traffic Class	1419
Creating a Policy Map	1419
Defining QoS Actions in a Policy Map	1420
Set Actions	1420
Configuring Aggregate Port-Channel Interface	1420
Attaching a Traffic Policy to an Interface	1420
Example: Configuring Input MQC on the Port-Channel Interfaces	1420
Additional References	1421
Feature Information for Modular Quality of Service Command-Line Interface QoS	1422

---

**CHAPTER 90**

<b>DOCSIS 1.1 for the Cisco CMTS Routers</b>	<b>1423</b>
Hardware Compatibility Matrix for the Cisco cBR Series Routers	1423
Prerequisites for DOCSIS 1.1 Operations	1425
Restrictions for DOCSIS 1.1 Operations	1425
Information about DOCSIS 1.1	1427
Baseline Privacy Interface Plus	1428
Concatenation	1428
Dynamic MAC Messages	1428
Enhanced Quality of Service	1429
Fragmentation	1429
Interoperability	1430

Payload Header Suppression	1430
Downstream ToS Overwrite	1430
DOCSIS 1.1 Quality of Service	1431
Service Flow	1431
Service Class	1432
Packet Classifiers	1432
Packet Header Suppression Rules	1433
Quality of Service Comparison	1433
Enhanced Rate Bandwidth Allocation (ERBA) Support for DOCSIS 1.0 Cable Modems	1435
DOCSIS 3.0 Downstream Peak Traffic Rate TLV Support for ERBA	1436
Suppressing Upstream and Downstream Peak Rate TLVs for pre DOCSIS 3.0 Cable Modems	1437
Downstream Classification Enhancement with MAC Addresses	1438
Benefits	1438
How to Configure the Cisco CMTS for DOCSIS 1.1 Operations	1440
Configuring Baseline Privacy Interface	1440
Downloading the DOCSIS Root Certificate to the CMTS	1443
Adding a Manufacturer's Certificate as a Trusted Certificate	1445
Adding a Certificate as a Trusted Certificate Using SNMP Commands	1445
Adding a Manufacturer's or CM Certificate to the Hotlist	1447
Adding a Certificate to the Hotlist Using SNMP Commands	1447
Enabling Concatenation	1448
Enabling DOCSIS Fragmentation	1449
Enabling DOCSIS 1.1 Downstream Maximum Transmit Burst on the Cisco cBR-8 Router	1451
Monitoring DOCSIS Operations	1452
Monitoring the DOCSIS Network	1452
Displaying the Status of Cable Modems	1452
Displaying a Summary Report for the Cable Modems	1454
Displaying the Capabilities of the Cable Modems	1454
Displaying Detailed Information About a Particular Cable Modem	1454
Monitoring the RF Network and Cable Interfaces	1455
Displaying Information About Cloned Cable Modems	1455
Denying RF Access For Cable Modems	1455
Displaying Information About the Mac Scheduler	1455
Displaying Information About QoS Parameter Sets	1455



Displaying Information About Service Flows	1455
Displaying Information About Service IDs	1456
Monitoring BPI+ Operations	1456
Displaying the Current BPI+ State of Cable Modems	1456
Displaying the BPI+ Timer Values on the CMTS	1457
Displaying the Certificate List on the CMTS	1457
Configuration Examples for DOCSIS 1.1 Operations	1458
Example: DOCSIS 1.1 Configuration for Cisco cBR-8 Router (with BPI+)	1458
Additional References	1461
Feature Information for DOCSIS 1.1 for Cisco CMTS Routers	1462

**CHAPTER 91****Default DOCSIS 1.0 ToS Overwrite 1463**

Hardware Compatibility Matrix for the Cisco cBR Series Routers	1463
Restrictions for Default DOCSIS 1.0 ToS Overwrite	1464
Information About Default DOCSIS 1.0 ToS Overwrite	1465
Default DOCSIS 1.0 ToS Overwrite Overview	1465
DOCSIS	1465
Type-of-Service (ToS)	1465
How to Configure Default DOCSIS 1.0 ToS Overwrite	1466
Enabling Default DOCSIS 1.0 ToS Overwrite	1466
Editing QoS Profiles	1467
Additional References	1467
Feature Information for Default DOCSIS 1.0 ToS Overwrite	1468

**CHAPTER 92****DOCSIS WFQ Scheduler on the Cisco CMTS Routers 1469**

Hardware Compatibility Matrix for the Cisco cBR Series Routers	1469
Prerequisites for DOCSIS WFQ Scheduler	1470
Restrictions for DOCSIS WFQ Scheduler	1471
Information About DOCSIS WFQ Scheduler	1471
Queue Types	1472
Priority Queues	1472
CIR Queues	1472
Best Effort Queues	1472
DOCSIS QoS Support	1473

Traffic Priority	1473
Maximum Sustained Traffic Rate	1474
Minimum Reserved Traffic Rate	1474
High Priority Traffic	1474
Enhanced Rate Bandwidth Allocation	1475
Peak Traffic Rate	1475
DOCSIS 3.0 Downstream Bonding Support with Bonding Group Dynamic Bandwidth Sharing	1476
How to Configure DOCSIS WFQ Scheduler	1477
Mapping DOCSIS Priority to Excess Ratio	1477
Verifying the Downstream Queues Information	1478
Additional References	1478
Feature Information for DOCSIS WFQ Scheduler	1478

**CHAPTER 93****Fairness Across DOCSIS Interfaces 1479**

Hardware Compatibility Matrix for the Cisco cBR Series Routers	1479
Prerequisites for Fairness Across DOCSIS Interfaces	1481
Restrictions for Fairness Across DOCSIS Interfaces	1481
Information About Fairness Across DOCSIS Interfaces	1481
On-demand CIR Acquisition	1482
Fairness Across Bonding Groups	1482
OFDM Channels	1482
Interface Bandwidth	1482
How to Configure Fairness Across DOCSIS Interfaces	1483
Configuring Fairness Across DOCSIS Interfaces	1483
Configuring Maximum Excess Information Rate Ratio	1483
Configuring Constant Excess Information Rate Demand	1484
Configuring Maximum Bonus Bandwidth	1485
Verifying the Fairness Across DOCSIS Interfaces	1486
Verifying Reservable Bandwidth	1486
Verifying Global Fairness Across DOCSIS Interfaces Status and Statistics	1488
Verifying Per-Controller Fairness Across DOCSIS Interfaces Status and Statistics	1488
Verifying Per-Interface Fairness Across DOCSIS Interfaces Status and Statistics	1489
Configuration Examples for Fairness Across DOCSIS Interfaces	1489
Example: Fairness Across DOCSIS Interfaces	1489

Example: Maximum EIR Demand Ratio	1489
Example: Constant EIR Demand	1490
Example: Maximum Bonus Bandwidth	1490
Additional References	1491
Feature Information for Fairness Across DOCSIS Interfaces	1491

**CHAPTER 94****Service Group Admission Control 1493**

Finding Feature Information	1493
Hardware Compatibility Matrix for the Cisco cBR Series Routers	1493
Restrictions for Service Group Admission Control	1494
Information About Service Group Admission Control	1495
Overview	1495
SGAC and Downstream Bandwidth Utilization	1495
Categorization of Service Flows	1495
Thresholds for Downstream Bandwidth	1496
Overview of Bonding Group Admission Control	1496
How to Configure, Monitor, and Troubleshoot Service Group Admission Control	1497
Defining Rules for Service Flow Categorization	1497
Naming Application Buckets	1499
Preempting High-Priority Emergency 911 Calls	1499
Calculating Bandwidth Utilization	1501
Enabling SGAC Check	1501
Configuration Examples for SGAC	1502
Example: SGAC Configuration Commands	1502
Example: SGAC for Downstream Traffic	1504
Additional References	1505
Feature Information for Service Group Admission Control	1506

**CHAPTER 95****Subscriber Traffic Management 1507**

Hardware Compatibility Matrix for the Cisco cBR Series Routers	1508
Restrictions for Subscriber Traffic Management on the Cisco CMTS Routers	1509
Information About Subscriber Traffic Management on the Cisco CMTS Routers	1510
Feature Overview	1510
Feature List	1510

Sliding Window for Monitoring Service Flows	1511
Weekend Monitoring	1512
SNMP Trap Notifications	1512
Cable Modem Interaction with the Subscriber Traffic Management Feature	1514
How to Configure the Subscriber Traffic Management Feature on the Cisco CMTS Routers	1515
Creating and Configuring an Enforce-Rule	1515
Examples	1517
Configuring Weekend Monitoring	1519
Prerequisites	1519
Restrictions	1519
Configuring Different Legacy Monitoring Conditions for Weekends	1519
Configuring Different Peak-Offpeak Monitoring Conditions for Weekends	1520
Disabling Weekend Monitoring	1521
Removing Weekend Monitoring Conditions and Use the Same Monitoring Criteria Every Day	1522
Disabling an Enforce-Rule	1523
Removing an Enforce-Rule	1523
Changing a Cable Modem Service Class	1524
Monitoring the Subscriber Traffic Management Feature on the Cisco CMTS Routers	1525
Displaying the Currently Defined Enforce-Rules	1525
Displaying the Current Subscriber Usage	1527
Configuration Examples for Subscriber Traffic Management on the Cisco CMTS Routers	1528
Example: DOCSIS Configuration File and STM Service Classes	1528
Example: Downstream Configuration	1530
Example: Upstream Configuration	1530
Example: Downstream and Upstream Configuration	1530
Example: Weekend Monitoring Configuration	1531
Additional References	1531
Feature Information for Subscriber Traffic Management	1533

**CHAPTER 96****Narrowband Digital Forward And Narrowband Digital Return 1535**

Hardware Compatibility Matrix for the Cisco cBR Series Routers	1535
Information About NDF and NDR	1537
Restrictions for Configuring NDF and NDR	1537
1x2 RPD	1537

2x2 RPD	1537
Configure NDF and NDR	1538
Configure Static-Pseudowires for NDF and NDR	1538
Configure NDF and NDR Profile	1541
Bind NDF Static-Pseudowire and NDF Profile with Rf-Port	1542
Bind NDR Static-Pseudowire and NDR Profile with Rf-Port	1542
Display TLV Status	1542
Example: NDF Configuration	1544
Example: NDR Configuration	1544
Feature Information for Narrowband Digital Forward And Narrowband Digital Return	1545

---

**CHAPTER 97****Differentiated Services Code Point Downstream** 1547

Information About Differentiated Services Code Point Downstream Marking	1547
Feature Information for Differentiated Services Code Point Downstream Marking	1548

---

**PART XII****Security and Cable Monitoring Configuration** 1549

---

**CHAPTER 98****Dynamic Shared Secret** 1551

Hardware Compatibility Matrix for the Cisco cBR Series Routers	1552
Prerequisites for Dynamic Shared Secret	1553
Restrictions for Dynamic Shared Secret	1553
General Restrictions for Dynamic Shared Secret	1553
Cable Modem Restrictions for Dynamic Shared Secret	1554
DHCP Restriction for Incognito Server and Thomson Cable Modems	1554
DOCSIS Compliance	1555
TFTP Restrictions	1556
Information About Dynamic Shared Secret	1557
Modes of Operation	1557
Operation of the Dynamic Shared Secret	1558
Interaction with Different Commands	1559
Performance Information	1559
SNMP Support	1560
System Error Messages	1560
Benefits	1561

Related Features	1562
How to Configure the Dynamic Shared Secret Feature	1563
Enabling and Configuring the Dynamic Shared Secret Feature	1563
Disabling the Dynamic Shared Secret on a Cable Interface	1565
Excluding Cable Modems from the Dynamic Shared Secret Feature	1566
Clearing the Lock on One or More Cable Modems	1567
Upgrading Firmware on the Cable Modems	1568
How to Monitor the Dynamic Shared Secret Feature	1569
Displaying Marked Cable Modems	1569
Displaying the Current Dynamic Secrets	1570
Troubleshooting Cable Modems with Dynamic Shared Secret	1572
Configuration Examples for Dynamic Shared Secret	1573
Mark Configuration: Example	1573
Lock Configuration: Example	1574
Reject Configuration: Example	1575
Disabled Configuration: Example	1575
Additional References	1575
Feature Information for Dynamic Shared Secret	1576

---

**CHAPTER 99**
**Lawful Intercept Architecture 1577**

Hardware Compatibility Matrix for the Cisco cBR Series Routers	1577
Prerequisites for Lawful Intercept	1579
Restrictions for Lawful Intercept	1579
Information About Lawful Intercept	1580
Introduction to Lawful Intercept	1580
Cisco Service Independent Intercept Architecture	1580
PacketCable Lawful Intercept Architecture	1580
Cisco cBR Series Routers	1581
VRF Aware LI	1582
Lawful Intercept- Redundant Mediation Devices	1582
Lawful Intercept MIBs	1582
Restricting Access to the Lawful Intercept MIBs	1582
Service Independent Intercept	1583
Restricting Access to Trusted Hosts (without Encryption)	1583

How to Configure Lawful Intercept	1584
Creating a Restricted SNMP View of Lawful Intercept MIBs	1584
Where to Go Next	1585
Enabling SNMP Notifications for Lawful Intercept	1585
Disabling SNMP Notifications	1586
Provisioning a MAC Intercept for Cable Modems Using SNMPv3	1587
Provisioning a MAC Intercept for a CPE Device Using SNMPv3	1587
Configuration Examples for Lawful Intercept	1588
Example: Enabling Mediation Device Access Lawful Intercept MIBs	1588
Example: Configuring Lawful Intercept- Redundant Mediation Devices	1588
Additional References	1589
Feature Information for Lawful Intercept	1590

---

<b>CHAPTER 100</b>	<b>Cable Monitoring Feature for Cisco cBR Series Routers</b>	<b>1591</b>
	Overview of Cable Monitor Command for cBR	1592
	Configuring Cable Monitoring for cBR Routers	1592
	Capturing Sniffed Packets	1594
	Capturing Sniffed Packets on an External Host	1594
	Capturing Sniffed Packets on a Local Hard Drive	1595
	Cable Monitor Packet Struct	1597
	Feature Information for Cable Monitoring	1597

---

<b>CHAPTER 101</b>	<b>Source-Based Rate Limit</b>	<b>1599</b>
	Hardware Compatibility Matrix for the Cisco cBR Series Routers	1599
	Prerequisites for Source-Based Rate Limit	1600
	Restrictions for Source-Based Rate Limit	1601
	Information About Source-Based Rate Limit	1601
	How to Configure Source-Based Rate Limit	1601
	Configuring WAN-Side Source-Based Rate Limit	1602
	Configuring Control Plane Policing	1602
	Enabling WAN-Side Source-Based Rate Limit	1604
	Configuring WAN-Side Quarantine	1604
	Configuring Subscriber-Side Source-Based Rate Limit	1605
	Configuring Source-Based Rate Limit Ping-Bypass	1607

Configuring SNMP RX Queuing	1607
Configuring Punt Policing	1609
Verifying the Source-Based Rate Limit Configuration	1609
Configuration Examples for Source-Based Rate Limit	1614
Default SBRL Configuration	1616
Conversion of SBRL Subscriber-side Configuration from 16.8.x to 16.9.x	1617
Conversion of Divert Rate Limit Configuration on the Cisco uBR10012 Router to SBRL Configuration on the Cisco cBR Series Routers	1618
Additional References	1621
Feature Information for Source-Based Rate Limit	1621

**CHAPTER 102****Cable Duplicate MAC Address Reject 1623**

Hardware Compatibility Matrix for the Cisco cBR Series Routers	1623
Prerequisites for Cable Duplicate MAC Address Reject	1625
Restrictions for Cable Duplicate MAC Address Reject	1625
Information About Cable Duplicate MAC Address Reject	1625
Early Authentication and Encryption	1626
EAE Enforcement Policies	1626
EAE Exclusion	1626
BPI+ Security and Cloned Cable Modems	1626
Logging of Cloned Cable Modems	1627
DOCSIS 3.0 BPI+ Policy Enforcement	1627
BPI+ Policy Enforcement Exclusion	1628
How to Configure EAE and BPI+ Enforcement Features	1628
Configuring EAE Enforcement Policies	1628
Configuring BPI+ Enforcement Policies	1629
Configuring AES-128 for non-MTC DOCSIS3.0 Cable Modem	1630
Verifying AES-128 for non-MTC DOCSIS3.0 Cable Modem	1630
Troubleshooting Tips	1630
Configuration Example for EAE and BPI+ Enforcement Policies	1631
Verifying EAE and BPI+ Enforcement Policies	1631
What to Do Next	1631
System Messages Supporting Cable Duplicate MAC Address Reject	1632
Additional References	1633



Feature Information for Cable Duplicate MAC Address Reject 1633

---

**CHAPTER 103**

**Cable ARP Filtering 1635**

Hardware Compatibility Matrix for the Cisco cBR Series Routers 1635

Restrictions for Cable ARP Filtering 1637

Cable ARP Filtering 1637

Overview 1638

Filtering ARP Traffic 1638

Monitoring Filtered ARP Traffic 1639

ARP Autoreply 1639

Linksys Wireless-Broadband Router (BEFW11S4) 1639

ARP Filtering in FP 1640

Filtering ARP Traffic in FP 1640

How to Configure Cable ARP Filtering 1641

Monitoring ARP Processing 1641

Configure ARP Autoreply 1642

Configure ARP Filter Without ARP Autoreply 1644

Enabling ARP Filtering 1644

Identifying the Sources of Major ARP Traffic 1645

Examples 1648

Clearing the Packet Counters 1648

Identifying ARP Offenders in FP 1649

cBR-8 Outputs in FP 1649

Configuration Examples for Cable ARP Filtering 1650

ARP Filtering Configuration on an Individual Cable Interface: Example 1650

ARP Filtering Configuration on Bundled Cable Interfaces: Example 1651

ARP Filtering in FP Default Configuration: Example 1652

Additional References 1652

Feature Information for Cable ARP Filtering 1653

---

**CHAPTER 104**

**Subscriber Management Packet Filtering Extension for DOCSIS 2.0 1655**

Hardware Compatibility Matrix for the Cisco cBR Series Routers 1655

Prerequisites for Configuring Subscriber Management Packet Filtering 1657

Restriction for Configuring Subscriber Management Packet Filtering 1657

Information About Configuring Subscriber Management Packet Filtering 1657

How to Configure Subscriber Management Packet Filtering 1658

- Configuring the Filter Group 1658
- Defining the Upstream and Downstream MTA Filter Group 1659
- Defining the Upstream and Downstream STB Filter Group 1659
- Defining the Upstream and Downstream PS Filter Group 1660

Configuration Examples for Subscriber Management Packet Filtering 1661

- Configuring the Filter Group: Example 1661
- Defining the Upstream and Downstream MTA Filter Group: Example 1661
- Defining the Upstream and Downstream STB Filter Group: Example 1661
- Defining the Upstream and Downstream PS Filter Group: Example 1661

Additional References 1662

Feature Information for Subscriber Management Packet Filtering 1662

---

**CHAPTER 105**

**MAC Filtering 1663**

Hardware Compatibility Matrix for the Cisco cBR Series Routers 1663

Information About MAC Filtering 1665

How to Configure MAC Filtering 1665

- Configuring MAC Filtering 1665
- Verifying MAC Filtering 1665

Configuration Examples for MAC Filtering 1668

Feature Information for MAC Filtering 1668

---

**PART XIII**

**Troubleshooting and Network Management Configuration 1669**

---

**CHAPTER 106**

**Call Home 1671**

Hardware Compatibility Matrix for the Cisco cBR Series Routers 1671

Prerequisites for Call Home 1673

Restrictions for Call Home 1673

Information About Call Home 1673

- Benefits of Call Home 1674
- Obtaining Smart Call Home Services 1674

  - Anonymous Reporting 1675
  - Smart Licensing 1675

How to Configure Call Home	1676
Configuring Smart Call Home (Single Command)	1676
Configuring Call Home	1677
Enabling and Disabling Call Home	1677
Configuring Contact Information	1678
Configuring Destination Profiles	1679
Subscribing to Alert Groups	1684
Configuring General Email Options	1689
Sending Call Home Messages Manually	1694
Configuring Diagnostic Signatures	1698
Prerequisites for Diagnostic Signatures	1698
Information About Diagnostic Signatures	1699
Diagnostic Signature Overview	1699
Diagnostic Signature Downloading	1699
Diagnostic Signature Signing	1700
Diagnostic Signature Workflow	1700
Diagnostic Signature Events and Actions	1701
How to Configure Diagnostic Signatures	1703
Configuring the Service Call Home for Diagnostic Signatures	1703
Configuring Diagnostic Signatures	1705
Verifying the Call Home Configuration	1706
Configuration Example for Call Home	1710
Example: Call Home Configuration	1710
Example: Configuring HTTP Transport for Call Home on the Cisco cBR Series Router	1711
Example: Configuring Email Transport for Call Home on the Cisco cBR Series Router	1713
Default Settings	1716
Alert Groups Trigger Events and Commands	1717
Message Contents	1721
Sample syslog Alert Notification in XML Format	1725
Additional References	1734
Feature Information for Call Home	1735
<b>CHAPTER 107</b>	<b>Platform Automated Monitoring 1737</b>
	Platform Automated Monitoring 1737

---

<b>CHAPTER 108</b>	<b>SNMP Support over VPNs—Context-Based Access Control</b>	<b>1743</b>
	Finding Feature Information	1743
	Hardware Compatibility Matrix for the Cisco cBR Series Routers	1743
	Restrictions for SNMP Support over VPNs—Context-Based Access Control	1745
	Information About SNMP Support over VPNs—Context-Based Access Control	1745
	SNMP Versions and Security	1745
	SNMPv1 or SNMPv2 Security	1745
	SNMPv3 Security	1746
	SNMP Notification Support over VPNs	1746
	VPN-Aware SNMP	1746
	VPN Route Distinguishers	1747
	SNMP Contexts	1747
	How to Configure SNMP Support over VPNs—Context-Based Access Control	1748
	Configuring an SNMP Context and Associating the SNMP Context with a VPN	1748
	Configuring SNMP Support and Associating an SNMP Context	1749
	Configuration Examples for SNMP Support over VPNs—Context-Based Access Control	1751
	Example: Configuring Context-Based Access Control	1751
	Additional References	1752
	Feature Information for SNMP Support over VPNs—Context-Based Access Control	1754

---

<b>CHAPTER 109</b>	<b>SNMP Engine Enhancement</b>	<b>1755</b>
	Hardware Compatibility Matrix for the Cisco cBR Series Routers	1755
	Restrictions for SNMP Cache Engine Enhancement	1756
	Information About SNMP Cache Engine Enhancement	1757
	How to Configure SNMP Cache Engine Enhancement	1757
	Verifying the SNMP Cache Engine Status	1758
	Additional References	1759
	Feature Information for SNMP Cache Engine Enhancement	1759

---

<b>CHAPTER 110</b>	<b>Onboard Failure Logging</b>	<b>1761</b>
	Finding Feature Information	1761
	Hardware Compatibility Matrix for the Cisco cBR Series Routers	1761
	Understanding OBFL	1763

Configuring OBFL	1763
Displaying OBFL Logging Information	1763
Clearing OBFL Logging	1764
Configuration and Verification Examples	1764
Feature Information for Onboard Failure Logging	1770

---

**CHAPTER 111**
**Control Point Discovery 1773**

Hardware Compatibility Matrix for the Cisco cBR Series Routers	1773
Prerequisites for Control Point Discovery	1774
Restrictions for Control Point Discovery	1775
Information About Control Point Discovery	1775
Control Points	1775
Network Layer Signaling (NLS)	1775
NLS for CPD	1775
Control Point Discovery	1776
CPD Protocol Hierarchy	1776
Control Relationship	1777
How to Configure CPD	1777
Enabling CPD Functionality	1777
Examples for CPD Enable	1778
Debugging CPD Functionality	1778
Configuring Control Relationship Identifier	1778
Examples	1779
Enabling NLS Functionality	1779
Examples	1780
Debugging NLS Functionality	1780
Configuring Authorization Group Identifier and Authentication Key	1780
Examples	1781
Configuring NLS Response Timeout	1781
Examples	1782
Additional References	1782
Feature Information for Control Point Discovery	1782

---

**CHAPTER 112**
**IPDR Streaming Protocol 1785**

Restrictions for Configuring IPDR Streaming Protocol	1785
Information About IPDR Streaming Protocol	1786
Data Collection Methodologies	1786
How to Configure IPDR Streaming Protocol	1787
Configuring the IPDR Session	1787
Configuring the IPDR Type	1788
Configuring the IPDR Collector	1788
Configuring the IPDR Associate	1789
Configuring the IPDR Template	1789
Configuring the IPDR Exporter	1790
Configure IPDR in IPv6 Mode	1791
Start IPDR connection by CMTS	1792
Configuration Examples for IPDR Streaming Protocol	1792
Example: Configuring the IPDR Session	1792
Example: Configuring the IPDR Type	1792
Example: Configuring the IPDR Collector	1792
Example: Configuring the IPDR Associate	1793
Example: Configuring the IPDR Template	1793
Example: Configuring the IPDR Exporter	1793
Verifying IPDR Streaming Protocol	1793
Verifying the IPDR Collector	1793
Verifying IPDR exporter	1794
Verifying IPDR session	1794
Verifying IPDR Session Collector	1794
Verifying IPDR Session Template	1795
Additional References	1795
Feature Information for IPDR Streaming Protocol	1795
<hr/>	
<b>CHAPTER 113</b>	<b>Usage-Based Billing (SAMIS) 1797</b>
	Hardware Compatibility Matrix for the Cisco cBR Series Routers 1797
	Prerequisites for Usage-Based Billing (SAMIS) 1798
	Restrictions for Usage-based Billing 1799
	Information About Usage-based Billing 1800
	Feature Overview 1800

Usage-Based Billing and DOCSIS Support on the Cisco CMTS Routers	1801
Standards	1801
IPDR Service Definition Schemas	1801
IPDR Schema List for DOCSIS 3.0	1801
IPDR Schema List for DOCSIS 3.1	1806
Modes of Operation	1808
Billing Record Format	1808
SNMP Support	1812
Benefits	1812
How to Configure the Usage-based Billing Feature	1812
Enabling Usage-based Billing Feature File Mode Using CLI Commands	1813
Enabling Usage-based Billing Feature File Mode Using SNMP Commands	1814
Examples for Enabling Usage Billing using SNMP Mode	1817
Enabling Usage-based Billing Feature Streaming Mode Using CLI Commands	1817
Enabling Usage-based Billing Feature Streaming Mode Using SNMP Commands	1819
Examples for SNMP Commands	1823
Enabling and Configuring the Secure Copy Protocol (optional)	1824
Configuring the Cisco CMTS for SSL Operation	1826
Prerequisites for CA	1826
Retrieving Records from a Cisco CMTS in File Mode	1826
Using SCP	1827
Using TFTP	1828
Using SNMP	1828
Using SNMP	1832
Examples To Transfer Using SNMP	1833
Disabling the Usage-based Billing Feature	1835
Configuring Certified SSL Servers for Usage-Based Billing	1836
Generating SSL Server Certification	1836
Configuring and Testing the Cisco CMTS for Certified SSL Server Support	1837
Monitoring the Usage-based Billing Feature	1838
Configuration Examples for Usage-based Billing	1840
File Mode Configuration (with Secure Copy)	1840
Non-Secure Streaming Mode Configuration	1840
Secure Streaming Mode Configuration	1840

---

<b>CHAPTER 114</b>	<b>Frequency Allocation Information for the Cisco CMTS Routers</b>	<b>1843</b>
	Frequency Allocation for the Cisco CMTS Routers	1843

---

<b>CHAPTER 115</b>	<b>Flap List Troubleshooting</b>	<b>1855</b>
	Finding Feature Information	1855
	Hardware Compatibility Matrix for the Cisco cBR Series Routers	1856
	Prerequisites for Flap List Troubleshooting	1857
	Restrictions for Flap List Troubleshooting	1857
	Information About Flap List Troubleshooting	1857
	Feature Overview	1857
	Information in the Flap List	1858
	Cisco Cable Manager and Cisco Broadband Troubleshooter	1859
	Benefits	1859
	How to Configure Flap List Troubleshooting	1860
	Configuring Flap List Operation Using the CLI (optional)	1860
	Clearing the Flap List and Counters Using the CLI (optional)	1861
	Enabling or Disabling Power Adjustment Using the CLI (optional)	1862
	Configuring Flap List Operation Using SNMP (optional)	1864
	Clearing the Flap List and Counters Using SNMP (optional)	1864
	How to Monitor and Troubleshoot Using Flap Lists	1865
	Displaying the Flap List Using the show cable flap-list Command	1865
	Displaying the Flap List Using the show cable modem flap Command	1866
	Displaying the Flap List Using SNMP	1866
	Displaying Flap-List Information for Specific Cable Modems	1868
	Example	1868
	Troubleshooting Suggestions	1869
	Troubleshooting Tips	1869
	Performing Amplitude Averaging	1869
	Using Other Related Commands	1870
	Configuration Examples for Flap List Troubleshooting	1871
	Additional References	1872
	Feature Information for Flap List Troubleshooting	1873



---

<b>CHAPTER 116</b>	<b>Maximum CPE and Host Parameters</b>	<b>1875</b>
	Finding Feature Information	1875
	Hardware Compatibility Matrix for the Cisco cBR Series Routers	1875
	Information About the MAX CPE and Host Parameters	1877
	MAX CPE	1877
	MAX Host	1878
	Specifying an Unlimited Value for Max Host	1879
	MAX CPE IP	1879
	MAX CPE IPv6	1879
	Interoperation of the Maximum CPE Parameters	1880
	Benefits	1880
	How to Configure the MAX CPE and Host Parameters	1880
	Configuring the Maximum Number of CPE Devices on the Cisco CMTS	1881
	Configuration Examples	1882
	Additional References	1883
	Feature Information for Maximum CPE and Host Parameters	1884
<b>CHAPTER 117</b>	<b>SNMP Background Synchronization</b>	<b>1885</b>
	Information About SNMP Background Synchronization	1885
	How to Configure SNMP Background Synchronization	1887
	Enabling SNMP Background Synchronization	1887
	Setting Data Interval	1887
	Verifying SNMP Background Synchronization	1887
	Configuring Example for SNMP Background Synchronization	1894
	Channel Utilization Consistency	1894
	Feature Information for SNMP Background Synchronization	1896
<b>CHAPTER 118</b>	<b>Online Offline Diagnostics</b>	<b>1897</b>
	Overview of Online Offline Diagnostics	1897
	Benefits of Online Offline Diagnostics	1897
	Prerequisites for Online Offline Diagnostics	1898
	Restrictions for Online Offline Diagnostics	1898
	How to Configure Online Offline Diagnostics	1898

---

Configuring Field Diagnostic Test **1898**  
Verifying the Testing Process **1898**  
Removing the Field Diagnostic Image from a Line Card **1899**  
Configuration Example for Online Offline Diagnostics **1899**  
Feature Information for Online Offline Diagnostics **1899**

---

**CHAPTER 119**

**Factory Reset 1901**

Factory Reset **1901**



## PART I

# Basic Configuration

- [Start Up Configuration of the Cisco cBR Router, on page 1](#)
- [Cisco Smart Licensing, on page 39](#)
- [Core Peak Bandwidth Licensing, on page 75](#)
- [Capped License Enforcement, on page 79](#)
- [Consolidated Packages and SubPackages Management, on page 85](#)
- [Support for 2x100G DPIC, on page 119](#)
- [G.8275.2 Telecom Profile, on page 133](#)
- [Model-Driven Telemetry, on page 147](#)





# CHAPTER 1

## Start Up Configuration of the Cisco cBR Router

This document describes the basic start up configuration tasks that must be completed on a Cisco cBR Series Converged Broadband Router.

- [Prerequisites for Configuring the Cisco CMTS, on page 2](#)
- [Booting and Logging onto the Cisco CMTS , on page 3](#)
- [First Time Boot Up with ROMMON, on page 3](#)
- [Configuration Register, on page 4](#)
- [Setting Environment Variables, on page 5](#)
- [Unsetting Environment Variables, on page 5](#)
- [Booting from the TFTP on the Cisco cBR, on page 6](#)
- [Listing Supported Devices, on page 6](#)
- [Booting from the Device on the Cisco cBR, on page 7](#)
- [Setting AUTOBOOT image in ROMMON, on page 7](#)
- [Verifying the ROMMON Version, on page 8](#)
- [Resetting the Cisco cBR, on page 9](#)
- [Configuring PTP, on page 9](#)
- [File Systems, on page 16](#)
- [Verification of Hardware Bring Up, on page 17](#)
- [Gigabit Ethernet Management Interface Overview, on page 25](#)
- [Gigabit Ethernet Port Numbering, on page 25](#)
- [IP Address Handling in ROMMON and the Management Ethernet Port, on page 25](#)
- [Gigabit Ethernet Management Interface VRF, on page 26](#)
- [Common Ethernet Management Tasks, on page 26](#)
- [Viewing the VRF Configuration, on page 26](#)
- [Setting a Default Route in the Management Ethernet Interface VRF, on page 27](#)
- [Setting the Management Ethernet IP Address, on page 27](#)
- [Telnetting over the Management Ethernet Interface, on page 27](#)
- [Pinging over the Management Ethernet Interface, on page 27](#)
- [Copy Using TFTP or FTP, on page 28](#)
- [NTP Server, on page 28](#)
- [SYSLOG Server, on page 28](#)
- [SNMP-Related Services, on page 28](#)
- [Domain Name Assignment, on page 28](#)
- [DNS service, on page 29](#)

- [RADIUS or TACACS+ Server, on page 29](#)
- [VTY lines with ACL, on page 29](#)
- [Configuring the AUX Port for Network Management , on page 29](#)
- [Preprovisioning the Supervisor in the Cisco cBR Chassis, on page 30](#)
- [Configuring the Gigabit Ethernet Interface for Network Management, on page 30](#)
- [Configuring the DTI Port on the Supervisor PIC, on page 31](#)
- [Configuring the TenGigabit Ethernet Interface for Network Management , on page 32](#)
- [Connecting the New Router to the Network , on page 33](#)
- [Setting Password Protection on the Cisco CMTS, on page 34](#)
- [Recovering Lost Password on the Cisco CMTS, on page 34](#)
- [Saving Your Configuration Settings, on page 36](#)
- [Reviewing Your Settings and Configurations, on page 37](#)
- [Recovering Unresponsive Modems, on page 37](#)

## Prerequisites for Configuring the Cisco CMTS

Complete these prerequisite steps before you power on and configure the Cisco CMTS:

- Ensure that your network supports reliable broadband data transmission. Your plant must be swept, balanced, and certified based on National Television Standards Committee (NTSC) or appropriate international cable plant recommendations. Ensure your plant meets all Data-over-Cable Service Interface Specifications (DOCSIS) downstream and upstream radio frequency (RF) requirements.
- Ensure that your Cisco CMTS is installed according to the instructions in the hardware installation guide available on Cisco.com.
- Ensure that all other required headend or distribution hub routing and network interface equipment is installed, configured, and operational (based on the supported services). This includes:
  - All routers
  - Servers ( Dynamic Host Configuration Protocol (DHCP) servers, Trivial File Transfer Protocol (TFTP) servers, and time-of-day (ToD) servers)
  - Network management systems
  - Other configuration or billing systems
- Ensure that DHCP and DOCSIS configuration files have been created and pushed to appropriate servers so that each CM, when initialized, can:
  - Transmit a DHCP request
  - Receive an IP address
  - Obtain TFTP and ToD server addresses
  - Download a DOCSIS configuration file (or updated software image if using Cisco uBR924 cable access routers or Cisco uBR910 cable data service units (DSUs) in your network)
- Ensure that customer premises equipment (CPE)—CMs or set-top boxes (STBs), PCs, telephones, or facsimile machines—meet requirements for your network and service offerings.
- Be familiar with your channel plan to assign appropriate frequencies. Outline your strategies for setting up bundling, if applicable to your headend or distribution hub. As appropriate, obtain:
  - Passwords
  - IP addresses
  - Subnet masks

- Device names

After these prerequisites are met, you are ready to configure the Cisco CMTS. This includes, at a minimum:

- Configuring a host name and password for the Cisco CMTS
- Configuring the CMTS to support IP over the cable plant and network backbone



**Note** If you plan to use service-class-based provisioning, the service classes must be configured at the CMTS before CMs attempt to make a connection.



**Note** Do not configure the **logging event link-status** command during system initialization. It may take long time or even stop the standby SUP from booting up.

## Booting and Logging onto the Cisco CMTS

The Cisco CMTS is administered using the Cisco command interpreter, called the EXEC. You must boot and log in to the router before you can enter an EXEC command.

**Step 1** [Connect to the console port on the Supervisor PIC](#) and the [Supervisor card](#).

**Step 2** Establish a terminal session. You can open terminal application (Hyper Terminal) on a PC as follows:

- Connect using: Direct to Com 1
- Set bits per second:9600
- Set data bits: 8
- Set parity: none
- Set stop bit: 1
- Set flow control: none

Type **no** when the following message is displayed:

```
Would you like to enter the initial dialog?[yes]: no
Router>
```

## First Time Boot Up with ROMMON

The Cisco cBR-8 boots up with ROMMON on the console with 9600 baud default configuration. It boots image either from TFTP or from local device. Local devices supported include the bootflash and USB.

Example of the boot up display:

```
Initializing Hardware ...~
```

```

System Bootstrap, Version 15.5(2r)S, RELEASE SOFTWARE
Copyright (c) 1994-2015 by cisco Systems, Inc.

Current image running: Boot ROM0

Last reset cause: PowerOn

CPUID: 0x000206d7
UCODE: 0x00000710_00000000
Viper version register: 0x14121111
Set Chassis Type to 13RU
Cisco cBR-8 platform with 50331648 Kbytes of main memory

rommon 1 >

```

## Configuration Register

The **confreg** ROMMON command displays the configuration and allows modification of the settings.

```

rommon > confreg

Configuration Summary
(Virtual Configuration Register: 0x0)
enabled are:
[ 0 ] break/abort has effect
[ 1 ] console baud: 9600
boot: ..... the ROM Monitor

do you wish to change the configuration? y/n [n]: y
enable "diagnostic mode"? y/n [n]:
enable "use net in IP bcast address"? y/n [n]:
enable "load rom after netboot fails"? y/n [n]:
enable "use all zero broadcast"? y/n [n]:
disable "break/abort has effect"? y/n [n]:
enable "ignore system config info"? y/n [n]:
change console baud rate? y/n [n]:
change the boot characteristics? y/n [n]:

Configuration Summary
(Virtual Configuration Register: 0x0)
enabled are:
[ 0 ] break/abort has effect
[ 1 ] console baud: 9600
boot: ..... the ROM Monitor
do you wish to change the configuration? y/n [n]:
Console baud rate options:
change console baud rate? y/n [n]: y
0=9600, 1=4800, 2=1200, 3=2400, 4=19200, 5=38400, 6=57600, 7=115200
enter rate [0]:
Boot characteristics options:
change the boot characteristics? y/n [n]: y

enter to boot:
0 = ROM Monitor
1 = the boot helper image
2-15 = boot system
[0]:

```



## Setting Environment Variables

No Environment variables are required to boot the Cisco IOS-XE image.

There are variables set by default. The ROMMON command **set** displays the default variables.

```
rommon > set
PS1=rommon ! >
?=0
rommon >
```

To set a variable, the format is VARIABLE="value".

The **set** command displays the new variable and the **sync** command saves the variable to NVRAM.



---

**Note** If the variable value has a space in between, specify the value within quotes.

---

```
rommon > set
PS1=rommon ! >
?=0
rommon > IP_ADDRESS=1.2.3.4
rommon > IP_SUBNET_MASK=255.255.255.128
rommon > DEFAULT_GATEWAY=1.2.9.10
rommon > TFTP_SERVER=1.2.3.6
rommon > sync
```

## Unsetting Environment Variables

The **unset** ROMMON command removes the Environment variables and the **sync** command saves the variable to NVRAM.

```
rommon 1 > set
PS1=rommon ! >
?=0
BSI=0
BOOT=bootflash:cbrsup-adventerprisek9.SSA.bin,12;
RANDOM_NUM=1357042312
RET_2_RTS=17:45:06 PDT Sat Dec 31 2011
RET_2_RCALTS=1325378706
rommon 2 > unset BOOT
rommon 3 > sync
rommon 4 > set
PS1=rommon ! >
?=0
BSI=0
RANDOM_NUM=1357042312
RET_2_RTS=17:45:06 PDT Sat Dec 31 2011
RET_2_RCALTS=1325378706
rommon 5 >
```

## Booting from the TFTP on the Cisco cBR

ROMMON boots up with default environment variables. The BinOS image is booted up from TFTP over the management port. This requires a minimum set of environment variables: IP\_ADDRESS, IP\_SUBNET\_MASK, DEFAULT\_GATEWAY, and TFTP\_SERVER.

**Step 1** Type the **set** command and define the required environment variables.

```
rommon > set
PS1=rommon ! >
?=0
rommon > IP_ADDRESS=1.2.3.4
rommon > IP_SUBNET_MASK=255.255.255.128
rommon > DEFAULT_GATEWAY=1.2.9.10
rommon > TFTP_SERVER=1.2.3.6
rommon > sync
```

**Step 2** Type the **sync** command to save the variables to NVRAM.

```
rommon 6 > sync
```

**Step 3** Type the **boot** command to load the image.

```
rommon 7 > boot tftp://tftpboot/username/cbrsup-universalk9.SSA.bin

IP_ADDRESS: 1.2.3.4
IP_SUBNET_MASK: 255.255.255.128
DEFAULT_GATEWAY: 1.2.9.10
TFTP_SERVER: 1.2.3.6
TFTP_FILE: /tftpboot/username/cbrsup-universalk9.SSA.bin
TFTP_MACADDR: c4:14:3c:17:e8:00
TFTP_VERBOSE: Progress
TFTP_RETRY_COUNT: 18
TFTP_TIMEOUT: 7200
TFTP_CHECKSUM: Yes
ETHER_PORT: 2

ETHER_SPEED_MODE: Auto Detect
link up.....
Receiving /tftpboot/username/cbrsup-universalk9.SSA.bin from 172.19.211.47
!!!!!!!!!!!!!!!!!!!!!!!!!!!!!!!!!!!!!!!!!!!!!!!!!!!!!!!!!!!!!!!!!!!!!!!!!!!!
```

## Listing Supported Devices

The **dev** command lists the devices supported on the router.

```
rommon 1 > dev
Devices in device table:
  id name
  harddisk: Internal hard disk
  bootflash: Internal flash drive
  usb0: External USB drive 0
```

```
usb1: External USB drive 1
rommon 2 >
```

## Booting from the Device on the Cisco cBR

**Step 1** Type the **dir bootflash:** command.

```
rommon > dir bootflash:
File System: EXT2/EXT3

12          691955580 -rw-r--r--      cbrsup-xe315.SSA.bin
45          83475     -rw-r--r--      reload.log.20120103004502
```

**Step 2** Type the **boot bootflash:imagenam** command.

```
rommon > boot bootflash:cbrsup-xe315.bin
File size is 0x293e67bc
Located cbrsup-xe315.bin
Image size 691955644 inode num 145153, bks cnt 168935 blk size 8*512
#####
```

## Setting AUTOBOOT image in ROMMON

To set AUTOBOOT of an image from bootflash:, add the Environment Variable BOOT and then change the configuration register boot characteristics to boot and reset the system.

**Step 1** Type the **boot=bootflash:imagenam** command to load the image.

```
rommon > BOOT=bootflash:cbrsup-xe315-20150131.bin
```

**Step 2** Type the **sync** command to copy the variables to NVRAM.

```
rommon > sync
```

**Step 3** Type the **confreg** command to configure and modify the settings.

```
rommon > confreg

Configuration Summary
(Virtual Configuration Register: 0x0)
enabled are:
[ 0 ] break/abort has effect
[ 1 ] console baud: 9600
boot: ..... the ROM Monitor

do you wish to change the configuration? y/n [n]: y
enable "diagnostic mode"? y/n [n]:
enable "use net in IP bcast address"? y/n [n]:
enable "load rom after netboot fails"? y/n [n]:
enable "use all zero broadcast"? y/n [n]:
```

```

disable "break/abort has effect"? y/n [n]:
enable "ignore system config info"? y/n [n]:
change console baud rate? y/n [n]: n
change the boot characteristics? y/n [n]: y

enter to boot:
0 = ROM Monitor
1 = the boot helper image
2-15 = boot system
[0]: 2

Configuration Summary
(Virtual Configuration Register: 0x2)
enabled are:
[ 0 ] break/abort has effect
[ 1 ] console baud: 9600
boot: ..... image specified by the boot system commands or default to: cisco2-Cisco cBR-8

do you wish to change the configuration? y/n [n]:

You must reset or power cycle for new config to take effect

```

**Step 4** Type the **reset** command for the new configuration to take effect.

```
rommon > reset
```

### What to do next

## Verifying the ROMMON Version

Use the **showmon** command to display the version of ROMMON.

```

rommon > showmon
Current image running (0/1): Boot ROM0
System Bootstrap, Version 15.5(2r)S, RELEASE SOFTWARE
Copyright (c) 1994-2015 by cisco Systems, Inc.

Viper version register: 0x14121111
rommon >

```

**Table 1: Feature History**

Feature Name	Release Information	Feature Description
ROMMON Enhancements	Cisco IOS XE Dublin 17.12.1w	With this release, ROMMON autoupgrade takes place when the existing ROMMON version is older than version 16.7(9r)S. Manual ROMMON upgrade continues to be supported.  In ROMMON version 16.7(9r)S, we remove DEV key support from cBR-8 routers. You need a challenge key if you need to run an engineer-signed image.

### Running Private Cisco IOS XE Images

Use the **devkey** command to get the one-time token. The Cisco support team can use that token to generate the Dev Keys(same as Dev Mode).

```
rommon 1 > devkey
E7B06AE8877E3421
```

Once the Dev Keys are available, configure the Dev Keys in the ROMMON prompt.

```
rommon 2 > DEVKEY0=AE079099BADAEA16C731A667A57BC06D32586C2767631965C607C4842F62F20E
rommon 3 > DEVKEY1=3E926BB3EE3163C805AD908305C5118E3A1F7964BE400240B7850EAF9773C6F
rommon 4 > DEVKEY2=D9353C68B75EF526957D95E773A8E680AEE81E7C1DFCC2A56F2AF1B257B075CA
rommon 5 > DEVKEY3=07E48CFF98697CEA4129AF04894C7BC160DB552152B4A05210674CA38F08B247
rommon 7 > DEVKEY4=E4D29277DC246F0427D711360E36B193BB9D2969F0B42EF5EE5019E7C80E0535
rommon 8 > DEVKEY5=D45CC1D9B50FED89B17D1674938F9BD7AE1F10F23A46EB95FED5F5593D717F46
rommon 9 > DEVKEY6=2778650684521852B0EFA3B5D95F92A3729F3A99645B802ACA781AA243BFC965
rommon 10> DEVKEY7=F5FA33BC31755EAD97EC376509D52FE89D397B119CE59D26EE310E0DF562003B
```

After setting the Dev Key, you can only boot a private IOS image **once**.



---

**Note** Saving tokens in the ROMMON environment does not work. It is necessary to generate the token every time a private image needs to run.

---

## Resetting the Cisco cBR

Use the **reset** command to soft reset the Supervisor.

```
rommon > reset

Resetting .....

Initializing Hardware ...~

System Bootstrap, Version 15.5(2r)S, RELEASE SOFTWARE
Copyright (c) 1994-2015 by cisco Systems, Inc.

Current image running: Boot ROM0

Last reset cause: LocalSoftware

CPUID: 0x000206d7
UCODE: 0x00000710_00000000
Viper version register: 0x14121111
Set Chassis Type to 13RU
Cisco cBR-8 platform with 50331648 Kbytes of main memory

rommon >
```

## Configuring PTP

The Cisco cBR supports Precision Time Protocol (PTP) boundary or ordinary clock (OC) subordinate mode when connected to the Ethernet ports of the DPIC card or Supervisor PIC card. This topic provides you with

a an overview of PTP, configuration options, commands to verify the configuration settings, and configuration examples.

Cisco cBR supports DPIC PTP subordinate configuration with the following restraints:

- Only subordinate mode is supported.
- Only one-step timestamping is supported

## Overview of PTP

Precision Time Protocol (PTP) is a packet-based two-way message exchange protocol for synchronizing clocks between nodes in a network, thus providing an accurate time distribution over a network. PTP support is based on the IEEE 1588-2008 standard.

IEEE Standard 1588-2008 defines a method for distributing time around a network using the Precision Time Protocol (PTP) version 2. IEEE 1588-2008 is designed to provide precise timing and synchronization over packet-based Ethernet infrastructures without layer-1 support along the clocking path. PTP ensures that the best available clock is selected as the source of time (the grandmaster clock) for the network and that other clocks in the network are synchronized to the grandmaster.

PTP consists of two parts:

- The port state machine and the best primary clock algorithm: Provides a method to determine which ports in the network run as primary (providing time to other clocks to the network), which runs as subordinate (receiving time from other clocks in the network), and which are passive (neither primary nor subordinate).
- Mechanisms for subordinate ports to calculate the difference between the time of their own clocks and the time of their primary clock. To calculate the differences, PTP uses delay request and response mechanism and a peer delay mechanism.

An overview of clock synchronization is explained.

**Figure 1: Clock Synchronization**

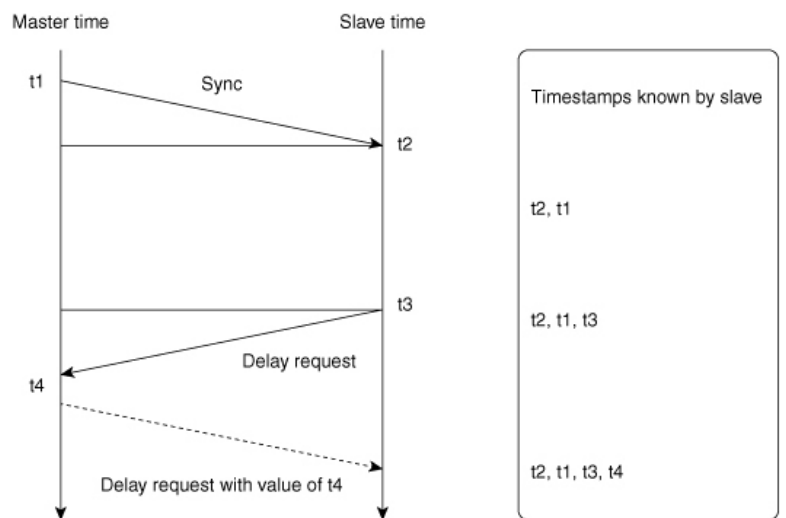

After the primary-subordinate clock hierarchy is established, the clock synchronization process starts. The message exchange occurs in this sequence:

1. The primary clock sends a `Sync` message. The time at which the `Sync` message leaves the primary is time-stamped as  $t_1$ .
2. The subordinate clock receives the `Sync` message and is time-stamped as  $t_2$ .
3. The subordinate sends the `Delay` request, which is time-stamped as  $t_3$  when it leaves the subordinate, and as  $t_4$  when the primary receives it.
4. The primary responds with a `Delay` request that contains the time stamp  $t_4$ .

PTP employs a hierarchy of clock types to ensure that precise timing and synchronization is maintained between the source and the numerous PTP clients that are distributed throughout the network. The types of clock are the following:

- Grandmaster clock

This clock is the highest-ranking clock within its PTP domain. PTP grandmasters can be deployed as either standalone devices or as plug-in modules or “blades” that can be integrated into an existing synchronization supply unit (SSU) or building integrated timing supply (BITS) shelf. Grandmasters are the primary reference source (PRS) for all other PTP elements within their PTP domain.

- Primary clock

The PTP primary has a precise clock, from a PRC or GPS. This clock drives the timestamp engine to derive accurate timestamps. The primary hosts PTP sessions with several subordinates.

- Subordinate clock

The subordinate is a network element that can recover the (Frequency and phase) clock from the timestamps that are obtained by messages that are exchanged with the PTP primary clock.

- Boundary clock

The Boundary clock acts as both PTP primary and subordinate. It is a subordinate to a grandmaster and derive the reference from the grandmaster. It then starts its own PTP sessions with several downstream subordinates. The advantage of placing a boundary clock is that it mitigates the number of network hops and resulting delays that occur in the packet network between the grandmaster and subordinates.

- Transparent clock

They maintain precise internal clocking by measuring the exact time difference between the packet entry and exit and the correction field of PTP packet is updated accordingly. Hence, the delay that is introduced by the node will not affect the PTP subordinate.

### PTP on Supervisor 250 Interfaces

Cisco cBR functions as a PTP subordinate when it has Supervisor 250 (CBR-SUP-250G) ports that are combined to form a port channel with an IPv6 address.

In this scenario, the Cisco cBR router locks with the remote PTP server which is also configured with an IPv6 address, through the port channel.



**Note** You can configure a maximum of two clock sources for PTP. If you configure three or more clock sources, the *ptpd\_mcp\_rp* process crashes when the PTP reaches the *PHASE ALIGNED* state.

## Configure PTP Subordinate Through DPIC

### Before you begin

You can configure PTP ports on Cisco cBR through the DPIC.

Configure the PTP subordinate using one of the following options:

- Subordinate mode with single source

```
config terminal
 ptp clock ordinary domain <domain id>
 servo tracking-type R-DTI
 clock-port <name> slave
 delay-req interval < Interval>
 sync interval < Interval>
 sync one-step
 transport <ipv4/ipv6> unicast interface <loopback name> negotiation
 clock source <clock ip>
```

- Subordinate mode with single source with profile G8275.2

```
config terminal
 ptp clock ordinary domain <domain id>
 servo tracking-type R-DTI
 clock-port <name> slave profile g8275.2
 delay-req interval < Interval>
 sync interval < Interval>
 sync one-step
 transport <ipv4/ipv6> unicast interface <loopback name> negotiation
 clock source <clock ip>
```

- Subordinate mode with multiple clock source

```
config t
 ptp clock ordinary domain <domain id>
 servo tracking-type R-DTI
 clock-port <name> slave
 delay-req interval < Interval>
 sync interval < Interval>
 sync one-step
 transport <ipv4/ipv6> unicast interface <loopback name> negotiation
 clock source <clock ip>
 clock source <clock ip> <local priority>
```

- Subordinate mode with multiple clock source with profile G8275.2

```
config t
 ptp clock boundary domain <domain id>
 servo tracking-type R-DTI
 clock-port <name> profile g8275.2
 delay-req interval < Interval>
 sync interval < Interval>
 sync one-step
 transport ipv6 unicast interface <loopback name> negotiation
```



```
clock source <clock ip>
clock-port <name> profile g8275.2
delay-req interval < Interval>
sync interval < Interval>
sync one-step
transport ipv6 unicast interface <loopback name> negotiation
clock source <clock ip>
```

---

## Configure Cisco cBR as PTP Subordinate

You can configure the Cisco cBR router to function as a PTP subordinate. The cBR router must have Supervisor 250 cards with an IPv6 port channel. Use the following sample commands to configure the router.

---

**Step 1** Configure a port-channel on the Cisco cBR router using the following sample command:

```
router#config port-channel 16
  cmts.config(''
    interface port-channel 16
    ip address %s 255.255.255.0
    ipv6 address %s/64
    no shut
  '' % (ipaddr_portchannel,ipaddr_portchannel_ipv6))
```

**Step 2** Configure the two ports that belong to this port-channel using the following sample command:

For example, you can configure one port on SUP-A and another port on SUP-B:

```
router#config port
  cmts.config(''
    interface %s
    channel-group 16
    no shut
  '' % cbr1588_mainint)
```

Configure the port-channel on the peer switch using the commands in Step 1.

**Step 3** Configure PTP on Cisco cBR using the following sample command:

```
router#sh run | sec ptp
ptp clock ordinary domain 55
servo tracking-type R-DTI
clock-port dp-ptp slave
delay-req interval -4
sync interval -5
sync one-step
transport ipv6 unicast interface Lo1588 negotiation
clock source ipv6 2001:10:90:3::93
```

**Step 4** Verify the configuration by pinging the PTP server IPv6 address.

The source is Lo1588 interface.

---

## Verifying PTP Subordinate Configuration

You can verify the PTP subordinate configuration by going through the following steps.

**Step 1** Verify the PTP configuration by running the **show run | se ptp** command.

**Example:**

```
router# show run | se ptp
ptp clock ordinary domain 55
servo tracking-type R-DTI
clock-port slave-from-903 slave
delay-req interval -5
sync interval -5
sync one-step
transport ipv4 unicast interface Lo1588 negotiation
clock source 10.90.3.93
```

**Step 2** To verify the PTP clock working state, use the **show ptp clock running** command.

The state `PHASE_ALIGNED` confirms a successful locking.

**Example:**

```
router# show ptp clock running
PTP Ordinary Clock [Domain 55]
State          Ports          Pkts sent      Pkts rcvd      Redundancy Mode
PHASE_ALIGNED 1              68938          138822         Hot standby
PORT SUMMARY
PTP Master
Name           Tx Mode        Role            Transport      State          Sessions      Port Addr
slave-from-903 unicast        slave           Lo1588         Slave          1             10.90.3.93
L06#
```

## PTP Subordinate Configuration Examples

The PTP subordinate example configurations are as follows:

- PTP subordinate mode with ipv4

```
config t
ptp clock ordinary domain 0
servo tracking-type R-DTI
clock-port slave-from-903 slave
delay-req interval -5
sync interval -5
sync one-step
transport ipv4 unicast interface Lo1588 negotiation
clock source 10.90.3.93
```

- PTP subordinate mode with ipv6

```
config t
ptp clock ordinary domain 0
servo tracking-type R-DTI
clock-port slave-from-903 slave
delay-req interval -4
```

```
sync interval -5
sync one-step
transport ipv6 unicast interface Lo1588 negotiation
clock source ipv6 2001:10:90:3::93
```

- PTP subordinate mode with ipv4 with profile G8275.2

```
config t
  ptp clock ordinary domain 55
  servo tracking-type R-DTI
  clock-port slave-from-903 slave profile g8275.2
  delay-req interval -4
  sync interval -5
  sync one-step
  transport ipv4 unicast interface Lo1588 negotiation
  clock source 10.90.3.93
```

- PTP subordinate mode with ipv6 with profile G8275.2

```
config t
  ptp clock ordinary domain 55
  servo tracking-type R-DTI
  clock-port slave-from-903 slave profile g8275.2
  delay-req interval -4
  sync interval -5
  sync one-step
  transport ipv6 unicast interface Lo1588 negotiation
  clock source ipv6 2001:10:90:3::93
```

- PTP subordinate mode with ipv4 with 2 clock sources

```
config t
  ptp clock ordinary domain 0
  servo tracking-type R-DTI
  clock-port slave-from-903 slave
  delay-req interval -5
  sync interval -5
  sync one-step
  transport ipv4 unicast interface Lo1588 negotiation
  clock source 10.90.3.93
  clock source 10.1.1.1 2
```

- PTP subordinate mode with ipv6 with 2 clock sources and with profile G8275.2

```
config t
  ptp clock boundary domain 55
  servo tracking-type R-DTI
  clock-port 22 profile g8275.2
  delay-req interval -4
  sync interval -5
  sync one-step
  transport ipv6 unicast interface Lo1588 negotiation
  clock source ipv6 2001:10:90:3::93
  clock-port 33 profile g8275.2
  delay-req interval -4
  sync interval -5
  sync one-step
  transport ipv6 unicast interface Lo1588 negotiation
  clock source ipv6 2001:158:158:158::7
```

## Feature Information for PTP Subordinate

Use Cisco Feature Navigator to find information about the platform support and software image support. Cisco Feature Navigator enables you to determine which software images support a specific software release, feature set, or platform. To access Cisco Feature Navigator, go to the <https://cfnng.cisco.com/> link. An account on the Cisco.com page is not required.



**Note** The following table lists the software release in which a given feature is introduced. Unless noted otherwise, subsequent releases of that software release train also support that feature.

**Table 2: Feature Information for PTP Subordinate**

Feature Name	Releases	Feature Information
PTP Subordinate Through DPIC	Cisco IOS-XE Release 16.8.1	This feature was introduced in Cisco IOS-XE Release 16.8.1 on Cisco cBR Series Converged Broadband Router.
PTP on Supervisor 250 Interfaces	Cisco IOS-XE Amsterdam 17.3.1	This feature was introduced in Cisco IOS-XE Release 17.3.1 on Cisco cBR Series Converged Broadband Router.

## File Systems

The Cisco cBR-8 router runs on the Cisco IOS-XE image. Supported file systems include:

1. IOS File System (IFS) in IOS
2. ext2, vfs, jffs2, tmpfs, autofs, and such common file systems in Linux

Features of the File Systems:

1. Both the Harddisk and USB are hot pluggable.
2. Harddisk is not accessible under Rommon.
3. Bootflash and USB disk are accessible under Rommon.
4. The **dir**, **show**, **copy**, **delete**, **mkdir**, **rmdir**, and **fsck** commands are supported for bootflash, harddisk and USB.

### File System Table in the Supervisor

Name	Device	Size	Type	Visible	Usage	Physical Description
bootflash	/dev/bootflash1	7800705024	ext2	IOS/Binos	image,IOSscrasinfo,etc	Partition1 of bootflash (eUSB flash).
flash	/dev/bootflash1	7800705024	ext2	IOS	image	A copy of bootflash.
nvrn	/dev/bootflash2	32M	N/A	IOS	configuration, etc	Partition2 of bootflash (eUSB flash).

Name	Device	Size	Type	Visible	Usage	Physical Description
harddisk	/dev/harddisk1	98394218496	ext2	IOS/Binos	tracelog,corefile,etc	Partition1 of the 100G harddisk.
usb0	/dev/usb11	8G	vfat	IOS/Binos	image	Two USBs can be inserted into one SUP.

## Verification of Hardware Bring Up

### Monitoring the Cisco cBR Chassis Using CLI

- **show platform**—Verify if the installed cards are in **Ok** or **Inserted** state.

```
Router# show platform
```

```
Chassis type: CBR-8-CCAP-CHASS
```

```

Slot      Type                State                Insert time (ago)
-----
1         CBR-CCAP-LC-40G    ok                   03:22:58
1/1      CBR-RF-PIC         ok                   03:19:40
SUP0     CBR-CCAP-SUP-160G inserted            03:22:58
  R0     ok, active
  F0     ok, active
  4      ok, active
  4/1    CBR-SUP-8X10G-PIC ok                   03:20:30
P0       PWR-2KW-DC-V2     ok                   03:21:20
P1       PWR-2KW-DC-V2     ok                   03:21:20
P2       PWR-2KW-DC-V2     ok                   03:21:20
P3       PWR-2KW-DC-V2     ok                   03:21:20
P4       PWR-2KW-DC-V2     ok                   03:21:20
P5       PWR-2KW-DC-V2     ok                   03:21:20
P10     CBR-FAN-ASSEMBLY  ok                   03:21:10
P11     CBR-FAN-ASSEMBLY  ok                   03:21:10
P12     CBR-FAN-ASSEMBLY  ok                   03:21:10
P13     CBR-FAN-ASSEMBLY  ok                   03:21:10
P14     CBR-FAN-ASSEMBLY  ok                   03:21:10

```

- **show platform hardware slot slot serdes status**—Verify if all the links are in **locked** state.

```
Router# show platform hardware slot F1 serdes status
```

```

Slot R1-Link A
  RX link locked
  58-bit scrambler, 20 Gbps
  0 Overruns, 0 Underruns
  0 Reframe, 0 Disparity
  0 Out of band, 0 Illegal control codes

```

```

Slot 3-Link A
  RX link locked
  58-bit scrambler, 20 Gbps
  0 Overruns, 0 Underruns
  0 Reframe, 0 Disparity
  0 Out of band, 0 Illegal control codes

```

```
Slot 5-Link A
```

```

RX link locked
58-bit scrambler, 20 Gbps
0 Overruns, 0 Underruns
0 Reframe, 0 Disparity
0 Out of band, 0 Illegal control codes

Slot 5-Link B
RX link locked
58-bit scrambler, 20 Gbps
0 Overruns, 0 Underruns
0 Reframe, 0 Disparity
0 Out of band, 0 Illegal control codes

Slot 5-Link C
RX link locked
58-bit scrambler, 20 Gbps
0 Overruns, 0 Underruns
0 Reframe, 0 Disparity
0 Out of band, 0 Illegal control codes

Slot 5-Link D
RX link locked
58-bit scrambler, 20 Gbps
0 Overruns, 0 Underruns
0 Reframe, 0 Disparity
0 Out of band, 0 Illegal control codes

Slot 5-Link E
RX link Init
58-bit scrambler, 20 Gbps
0 Overruns, 0 Underruns
0 Reframe, 0 Disparity
0 Out of band, 0 Illegal control codes

Slot 5-Link F
RX link Init
58-bit scrambler, 20 Gbps
0 Overruns, 0 Underruns
0 Reframe, 0 Disparity
0 Out of band, 0 Illegal control codes

Slot 5-Link G
RX link Init
58-bit scrambler, 20 Gbps
0 Overruns, 0 Underruns
0 Reframe, 0 Disparity
0 Out of band, 0 Illegal control codes

Slot 5-Link H
RX link Init
58-bit scrambler, 20 Gbps
0 Overruns, 0 Underruns
0 Reframe, 0 Disparity
0 Out of band, 0 Illegal control codes

```

- **show environment all**—Verify the environmental status of each FRU after installation.

This command displays the system temperature, voltage, fan, and power supply conditions.

```
Router# show environment all
```

```
Sensor List: Environmental Monitoring
Sensor      Location      State      Reading
AVCC&lP2: Sens  4/1          Normal     81 mV
```

AVCC&1P2: Vin	4/1	Normal	12600 mV
AVCC&1P2: ADin	4/1	Normal	0 mV
VP1P35: Sens	4/1	Normal	8 mV
VP1P35: Vin	4/1	Normal	12650 mV
VP1P35: ADin	4/1	Normal	112 mV
VP1P0: Sens	4/1	Normal	15 mV
VP1P0: Vin	4/1	Normal	12625 mV
VP1P0: ADin	4/1	Normal	0 mV
MGTAVTT: Sens	4/1	Normal	21 mV
MGTAVTT: Vin	4/1	Normal	12625 mV
MGTAVTT: ADin	4/1	Normal	0 mV
VP1P8: Sens	4/1	Normal	41 mV
VP1P8: Vin	4/1	Normal	12600 mV
VP1P8: ADin	4/1	Normal	0 mV
VP3P3: Sens	4/1	Normal	39 mV
VP3P3: Vin	4/1	Normal	12625 mV
VP3P3: ADin	4/1	Normal	0 mV
Temp: RTMAC	4/1	Normal	34 Celsius
Temp: INLET	4/1	Normal	29 Celsius
Temp: OUTLET	4/1	Normal	27 Celsius
Temp: MAX6697	4/1	Normal	50 Celsius
Temp: TCXO	4/1	Normal	37 Celsius
Temp: SUP_OUT	4/1	Normal	49 Celsius
Temp: 3882_1 P	4/1	Normal	44 Celsius
Temp: 3882_2 P	4/1	Normal	39 Celsius
Temp: 3882_3 P	4/1	Normal	39 Celsius
VP5P0: Sens	4/1	Normal	6 mV
VP5P0: Vin	4/1	Normal	12650 mV
VP5P0: ADin	4/1	Normal	0 mV
VP1P8: Sens	4/1	Normal	33 mV
VP1P8: Vin	4/1	Normal	12625 mV
VP1P8: ADin	4/1	Normal	0 mV
3P3&1P0: Sens	4/1	Normal	24 mV
3P3&1P0: Vin	4/1	Normal	12625 mV
3P3&1P0: ADin	4/1	Normal	0 mV
Temp: INLET PD	4/1	Normal	27 Celsius
Temp: OUTLETPD	4/1	Normal	36 Celsius
Temp: 6697-DC	4/1	Normal	38 Celsius
Temp: PHYOUT	4/1	Normal	49 Celsius
Temp: PHYIN	4/1	Normal	38 Celsius
Temp: SSD	4/1	Normal	40 Celsius
Temp: SFP+	4/1	Normal	36 Celsius
Temp: 3882_1PD	4/1	Normal	42 Celsius
3882_PC1_0: VO	4/1	Normal	1198 mV
3882_PC1_1: VO	4/1	Normal	999 mV
3882_PC2_0: VO	4/1	Normal	998 mV
3882_PC3_0: VO	4/1	Normal	1349 mV
PSOC-PC1_0: VO	4/1	Normal	3300 mV
PSOC-PC1_1: VO	4/1	Normal	12590 mV
PSOC-PC1_2: VO	4/1	Normal	6997 mV
PSOC-PC1_3: VO	4/1	Normal	5000 mV
PSOC-PC1_4: VO	4/1	Normal	3299 mV
PSOC-PC1_5: VO	4/1	Normal	1000 mV
PSOC-PC1_6: VO	4/1	Normal	1010 mV
PSOC-PC1_7: VO	4/1	Normal	1801 mV
PSOC-PC1_8: VO	4/1	Normal	2000 mV
PSOC-PC1_9: VO	4/1	Normal	1198 mV
PSOC-PC1_10: V	4/1	Normal	1798 mV
PSOC-PC1_11: V	4/1	Normal	2500 mV
PSOC-PC1_12: V	4/1	Normal	1353 mV
PSOC-PC1_13: V	4/1	Normal	1223 mV
PSOC-PC1_14: V	4/1	Normal	592 mV
PSOC-PC1_15: V	4/1	Normal	596 mV
3882_PDC_0: VO	4/1	Normal	1000 mV

3882_PDC_1: VO	4/1	Normal	3300 mV
PSOC-DC1_0: VO	4/1	Normal	4998 mV
PSOC-DC1_1: VO	4/1	Normal	3280 mV
PSOC-DC1_2: VO	4/1	Normal	1005 mV
PSOC-DC1_3: VO	4/1	Normal	1801 mV
PSOC-DC1_4: VO	4/1	Normal	2500 mV
12_CUR: Sens	9	Normal	14 mV
12_CUR: Vin	9	Normal	12650 mV
12_CUR: ADin	9	Normal	267 mV
G0_CUR: Sens	9	Normal	69 mV
G0_CUR: Vin	9	Normal	12550 mV
G0_CUR: ADin	9	Normal	0 mV
G1_CUR: Sens	9	Normal	69 mV
G1_CUR: Vin	9	Normal	12575 mV
G1_CUR: ADin	9	Normal	0 mV
LB_CUR: Sens	9	Normal	11 mV
LB_CUR: Vin	9	Normal	12525 mV
LB_CUR: ADin	9	Normal	0 mV
Temp: CAPRICA	9	Normal	40 Celsius
Temp: BASESTAR	9	Normal	47 Celsius
Temp: RAIDER	9	Normal	45 Celsius
Temp: CPU	9	Normal	31 Celsius
Temp: INLET	9	Normal	25 Celsius
Temp: OUTLET	9	Normal	35 Celsius
Temp: DIGITAL	9	Normal	31 Celsius
Temp: UPX	9	Normal	29 Celsius
Temp: LEOBEN1	9	Normal	31 Celsius
Temp: LEOBEN2	9	Normal	35 Celsius
Temp: 3.3-18	9	Normal	43 Celsius
Temp: BS_1V	9	Normal	45 Celsius
Freq: 5338-49	9	Normal	0 MHz
Freq: 5338-52	9	Normal	0 MHz
Freq: 5338-89	9	Normal	0 MHz
3882_1_0: VOUT	9	Normal	3299 mV
3882_1_1: VOUT	9	Normal	1800 mV
3882_2_0: VOUT	9	Normal	2500 mV
3882_2_1: VOUT	9	Normal	1199 mV
3882_3_0: VOUT	9	Normal	1419 mV
3882_4_0: VOUT	9	Normal	1350 mV
3882_5_0: VOUT	9	Normal	1000 mV
3882_6_0: VOUT	9	Normal	1021 mV
3882_7_0: VOUT	9	Normal	1199 mV
3882_7_1: VOUT	9	Normal	1000 mV
3882_8_0: VOUT	9	Normal	1000 mV
3882_9_0: VOUT	9	Normal	999 mV
V2978: VSENSE0	9	Normal	0 mV
V2978: VSENSE1	9	Normal	0 mV
V2978: VSENSE2	9	Normal	0 mV
V2978: VSENSE3	9	Normal	6000 mV
V2978: VSENSE4	9	Normal	2400 mV
V2978: VSENSE5	9	Normal	0 mV
V2978: VSENSE6	9	Normal	6598 mV
V2978: VSENSE7	9	Normal	4998 mV
V2978: VIN	9	Normal	25218 mV
PSOC_2_0: VOUT	9	Normal	12582 mV
PSOC_2_1: VOUT	9	Normal	4985 mV
PSOC_2_2: VOUT	9	Normal	3256 mV
PSOC_2_3: VOUT	9	Normal	1982 mV
PSOC_2_4: VOUT	9	Normal	1990 mV
PSOC_2_5: VOUT	9	Normal	1782 mV
PSOC_2_6: VOUT	9	Normal	1793 mV
PSOC_2_7: VOUT	9	Normal	1786 mV
PSOC_2_8: VOUT	9	Normal	1483 mV
PSOC_2_9: VOUT	9	Normal	1193 mV



PSOC_2_10: VOU	9	Normal	995 mV
PSOC_2_11: VOU	9	Normal	987 mV
PSOC_2_12: VOU	9	Normal	994 mV
PSOC_2_13: VOU	9	Normal	707 mV
PSOC_2_14: VOU	9	Normal	592 mV
PSOC_2_15: VOU	9	Normal	593 mV
LTC4261: Power	9	Normal	340 Watts
PEM Iout	P0	Normal	5 A
PEM Vout	P0	Normal	55 V DC
PEM Vin	P0	Normal	202 V AC
Temp: INLET	P0	Normal	26 Celsius
Temp: OUTLET	P0	Normal	48 Celsius
PEM Iout	P1	Normal	6 A
PEM Vout	P1	Normal	55 V DC
PEM Vin	P1	Normal	204 V AC
Temp: INLET	P1	Normal	30 Celsius
Temp: OUTLET	P1	Normal	53 Celsius
PEM Iout	P2	Normal	3 A
PEM Vout	P2	Normal	55 V DC
PEM Vin	P2	Normal	204 V AC
Temp: INLET	P2	Normal	25 Celsius
Temp: OUTLET	P2	Normal	51 Celsius
PSOC-MB2_0: VO	R0	Normal	12758 mV
PSOC-MB2_1: VO	R0	Normal	4998 mV
PSOC-MB2_2: VO	R0	Normal	7082 mV
PSOC-MB2_3: VO	R0	Normal	3287 mV
PSOC-MB2_4: VO	R0	Normal	989 mV
PSOC-MB2_5: VO	R0	Normal	1047 mV
PSOC-MB2_6: VO	R0	Normal	1500 mV
PSOC-MB2_7: VO	R0	Normal	1800 mV
PSOC-MB2_8: VO	R0	Normal	914 mV
PSOC-MB2_9: VO	R0	Normal	885 mV
PSOC-MB2_10: V	R0	Normal	994 mV
PSOC-MB2_11: V	R0	Normal	989 mV
PSOC-MB2_12: V	R0	Normal	1479 mV
PSOC-MB2_13: V	R0	Normal	989 mV
PSOC-MB2_14: V	R0	Normal	984 mV
PSOC-MB2_15: V	R0	Normal	890 mV
PSOC-MB2_16: V	R0	Normal	2485 mV
PSOC-MB2_17: V	R0	Normal	1346 mV
PSOC-MB2_18: V	R0	Normal	1458 mV
PSOC-MB2_19: V	R0	Normal	1208 mV
PSOC-MB2_20: V	R0	Normal	1791 mV
PSOC-MB2_21: V	R0	Normal	3293 mV
PSOC-MB2_22: V	R0	Normal	3250 mV
PSOC-MB2_23: V	R0	Normal	3284 mV
PSOC-MB2_24: V	R0	Normal	4970 mV
PSOC-MB2_25: V	R0	Normal	4451 mV
PSOC-MB3_0: VO	R0	Normal	4983 mV
PSOC-MB3_1: VO	R0	Normal	4979 mV
PSOC-MB3_2: VO	R0	Normal	1500 mV
PSOC-MB3_3: VO	R0	Normal	1192 mV
PSOC-MB3_4: VO	R0	Normal	705 mV
PSOC-MB3_5: VO	R0	Normal	752 mV
PSOC-MB3_6: VO	R0	Normal	579 mV
PSOC-MB3_7: VO	R0	Normal	1500 mV
PSOC-MB3_8: VO	R0	Normal	1501 mV
PSOC-MB3_9: VO	R0	Normal	1250 mV
PSOC-MB3_10: V	R0	Normal	1247 mV
PSOC-MB3_11: V	R0	Normal	1260 mV
PSOC-MB3_12: V	R0	Normal	1038 mV
PSOC-MB3_13: V	R0	Normal	1343 mV
PSOC-MB3_14: V	R0	Normal	670 mV
PSOC-MB3_15: V	R0	Normal	1800 mV

PSOC-MB3_16: V	R0	Normal	908 mV
PSOC-MB3_17: V	R0	Normal	823 mV
PSOC-MB3_18: V	R0	Normal	992 mV
PSOC-MB3_19: V	R0	Normal	984 mV
PSOC-MB3_20: V	R0	Normal	1046 mV
PSOC-MB3_21: V	R0	Normal	1192 mV
PSOC-MB3_22: V	R0	Normal	1169 mV
PSOC-MB3_23: V	R0	Normal	1187 mV
PSOC-MB3_24: V	R0	Normal	1796 mV
PSOC-MB3_25: V	R0	Normal	1792 mV
PSOC-MB3_26: V	R0	Normal	1787 mV
PSOC-MB3_27: V	R0	Normal	1034 mV
3882_MB1_0: VO	R0	Normal	1001 mV
3882_MB1_1: VO	R0	Normal	1022 mV
3882_MB2_0: VO	R0	Normal	1197 mV
3882_MB3_0: VO	R0	Normal	1045 mV
3882_MB3_1: VO	R0	Normal	996 mV
3882_MB4_0: VO	R0	Normal	898 mV
3882_MB5_0: VO	R0	Normal	1348 mV
3882_MB6_0: VO	R0	Normal	1350 mV
3882_MB6_1: VO	R0	Normal	3297 mV
3882_MB7_0: VO	R0	Normal	998 mV
3882_MB8_0: VO	R0	Normal	1501 mV
3882_MB8_1: VO	R0	Normal	1551 mV
3882_MB9_0: VO	R0	Normal	999 mV
3882_MB9_1: VO	R0	Normal	3296 mV
15301_1: VOUT	R0	Normal	2500 mV
15301_2: VOUT	R0	Normal	1200 mV
15301_3: VOUT	R0	Normal	1200 mV
AS_VRM: Sens	R0	Normal	40 mV
AS_VRM: Vin	R0	Normal	12725 mV
AS_VRM: ADin	R0	Normal	0 mV
Y0_VRM: Sens	R0	Normal	23 mV
Y0_VRM: Vin	R0	Normal	12675 mV
Y0_VRM: ADin	R0	Normal	380 mV
CPU_VCC: Sens	R0	Normal	6 mV
CPU_VCC: Vin	R0	Normal	12725 mV
CPU_VCC: ADin	R0	Normal	0 mV
5P0_BIAS: Sens	R0	Normal	19 mV
5P0_BIAS: Vin	R0	Normal	12700 mV
5P0_BIAS: ADin	R0	Normal	0 mV
7P0_BIAS: Sens	R0	Normal	45 mV
7P0_BIAS: Vin	R0	Normal	12725 mV
7P0_BIAS: ADin	R0	Normal	0 mV
1P0_AA: Sens	R0	Normal	37 mV
1P0_AA: Vin	R0	Normal	12700 mV
1P0_AA: ADin	R0	Normal	0 mV
1P0_RT: Sens	R0	Normal	16 mV
1P0_RT: Vin	R0	Normal	12725 mV
1P0_RT: ADin	R0	Normal	0 mV
1P2: Sens	R0	Normal	37 mV
1P2: Vin	R0	Normal	12675 mV
1P2: ADin	R0	Normal	0 mV
0P9_T0: Sens	R0	Normal	7 mV
0P9_T0: Vin	R0	Normal	12750 mV
0P9_T0: ADin	R0	Normal	0 mV
1P05_CPU: Sens	R0	Normal	11 mV
1P05_CPU: Vin	R0	Normal	12700 mV
1P05_CPU: ADin	R0	Normal	0 mV
1P0_CC: Sens	R0	Normal	16 mV
1P0_CC: Vin	R0	Normal	12700 mV
1P0_CC: ADin	R0	Normal	0 mV
1P35_DDR: Sens	R0	Normal	6 mV
1P35_DDR: Vin	R0	Normal	12725 mV

1P35_DDR: ADin	R0	Normal	0 mV
1P35_RLD: Sens	R0	Normal	0 mV
1P35_RLD: Vin	R0	Normal	12675 mV
1P35_RLD: ADin	R0	Normal	2047 mV
3P3_CCC: Sens	R0	Normal	16 mV
3P3_CCC: Vin	R0	Normal	12700 mV
3P3_CCC: ADin	R0	Normal	1375 mV
1P0_R: Sens	R0	Normal	29 mV
1P0_R: Vin	R0	Normal	12700 mV
1P0_R: ADin	R0	Normal	0 mV
1P5_A0: Sens	R0	Normal	41 mV
1P5_A0: Vin	R0	Normal	12700 mV
1P5_A0: ADin	R0	Normal	0 mV
1P5: Sens	R0	Normal	34 mV
1P5: Vin	R0	Normal	12675 mV
1P5: ADin	R0	Normal	0 mV
2P5: Sens	R0	Normal	5 mV
2P5: Vin	R0	Normal	12700 mV
2P5: ADin	R0	Normal	0 mV
1P8_A: Sens	R0	Normal	10 mV
1P8_A: Vin	R0	Normal	12675 mV
1P8_A: ADin	R0	Normal	947 mV
1P0_BV: Sens	R0	Normal	24 mV
1P0_BV: Vin	R0	Normal	12700 mV
1P0_BV: ADin	R0	Normal	0 mV
3P3: Sens	R0	Normal	16 mV
3P3: Vin	R0	Normal	12725 mV
3P3: ADin	R0	Normal	0 mV
1P2_B: Sens	R0	Normal	41 mV
1P2_B: Vin	R0	Normal	12725 mV
1P2_B: ADin	R0	Normal	0 mV
ADM1075: Power	R0	Normal	329 Watts
Temp: YO_DIE	R0	Normal	33 Celsius
Temp: BB_DIE	R0	Normal	29 Celsius
Temp: VP_DIE	R0	Normal	26 Celsius
Temp: RT-E_DIE	R0	Normal	31 Celsius
Temp: INLET_1	R0	Normal	23 Celsius
Temp: INLET_2	R0	Normal	22 Celsius
Temp: OUTLET_1	R0	Normal	25 Celsius
Temp: 3882_1	R0	Normal	46 Celsius
Temp: 3882_1A	R0	Normal	43 Celsius
Temp: 3882_1B	R0	Normal	43 Celsius
Temp: 3882_2	R0	Normal	41 Celsius
Temp: 3882_2A	R0	Normal	40 Celsius
Temp: 3882_2B	R0	Normal	41 Celsius
Temp: 3882_3	R0	Normal	37 Celsius
Temp: 3882_3A	R0	Normal	34 Celsius
Temp: 3882_3B	R0	Normal	33 Celsius
Temp: 3882_4	R0	Normal	46 Celsius
Temp: 3882_4A	R0	Normal	38 Celsius
Temp: 3882_4B	R0	Normal	35 Celsius
Temp: 3882_5	R0	Normal	32 Celsius
Temp: 3882_5A	R0	Normal	23 Celsius
Temp: 3882_5B	R0	Normal	23 Celsius
Temp: 3882_6	R0	Normal	37 Celsius
Temp: 3882_6A	R0	Normal	30 Celsius
Temp: 3882_6B	R0	Normal	32 Celsius
Temp: 3882_7	R0	Normal	38 Celsius
Temp: 3882_7A	R0	Normal	35 Celsius
Temp: 3882_7B	R0	Normal	35 Celsius
Temp: 3882_8	R0	Normal	47 Celsius
Temp: 3882_8A	R0	Normal	45 Celsius
Temp: 3882_8B	R0	Normal	41 Celsius
Temp: 3882_9	R0	Normal	37 Celsius

```

Temp: 3882_9A      R0      Normal      33 Celsius
Temp: 3882_9B      R0      Normal      32 Celsius
Temp: 8314_1       R0      Normal      40 Celsius
Temp: 8314_2       R0      Normal      36 Celsius
Temp: 3536_1A      R0      Normal      26 Celsius
Temp: 3536_1B      R0      Normal      26 Celsius
Temp: 15301_1A     R0      Normal      31 Celsius
Temp: 15301_1B     R0      Normal      32 Celsius
Temp: 15301_2A     R0      Normal      28 Celsius
Temp: 15301_2B     R0      Normal      34 Celsius
Temp: 15301_3A     R0      Normal      38 Celsius
Temp: 15301_3B     R0      Normal      45 Celsius
Temp: AS_DIE       R0      Normal      70 Celsius
Temp: XPT1_DTL     R0      Normal      42 Celsius
Temp: XPT1_DTR     R0      Normal      42 Celsius
Temp: XPT1_DBL     R0      Normal      42 Celsius
Temp: XPT1_DBR     R0      Normal      42 Celsius
Temp: XPT2_DTL     R0      Normal      42 Celsius
Temp: XPT2_DTR     R0      Normal      42 Celsius
Temp: XPT2_DBL     R0      Normal      42 Celsius
Temp: XPT2_DBR     R0      Normal      42 Celsius
Temp: XPT3_DTL     R0      Normal      42 Celsius
Temp: XPT3_DTR     R0      Normal      42 Celsius
Temp: XPT3_DBL     R0      Normal      42 Celsius
Temp: XPT3_DBR     R0      Normal      42 Celsius
Freq: MAX3674      R0      Normal      500 MHz
Freq: SQ420D       R0      Normal      24 MHz

```

• **show facility-alarm status** —Verify the chassis status.

```
Router# show facility-alarm status
```

```
System Totals Critical: 4 Major: 1 Minor: 8
```

Source	Time	Severity	Description [Index]
-----	-----	-----	-----
slot 3/0	Apr 13 2015 16:25:58	CRITICAL	Active Card Removed
OIR Alarm [0]			
Power Supply Bay 3 Module Missing [0]	Apr 13 2015 13:41:56	CRITICAL	Power Supply/FAN
Power Supply Bay 4 Module Missing [0]	Apr 13 2015 13:41:56	CRITICAL	Power Supply/FAN
Power Supply Bay 5 Module Missing [0]	Apr 13 2015 13:41:56	CRITICAL	Power Supply/FAN
Cable3/0/15-US0 Down [0]	Apr 13 2015 17:32:53	MINOR	Physical Port Link
Cable3/0/15-US1 Down [0]	Apr 13 2015 17:32:53	MINOR	Physical Port Link
Cable3/0/15-US2 Down [0]	Apr 13 2015 17:32:53	MINOR	Physical Port Link
Cable3/0/15-US3 Down [0]	Apr 13 2015 17:32:53	MINOR	Physical Port Link
Cable3/0/15-US4 Down [0]	Apr 13 2015 17:32:53	MINOR	Physical Port Link

# Gigabit Ethernet Management Interface Overview

The purpose of this interface is to allow users to perform management tasks on the router; it is basically an interface that should not and often cannot forward network traffic but can otherwise access the router, often via Telnet and SSH, and perform most management tasks on the router.

The following aspects of the Management Ethernet interface should be noted:

- Each SUP has a Management Ethernet interface, but only the active SUP has an accessible Management Ethernet interface (the standby SUP can be accessed using the console port, however).
- IPv4, IPv6, and ARP are the only routed protocols supported for the interface.
- The interface provides a method of access to the router even when some software processes are down.
- The Ethernet Management Interface cannot be used as a Lawful Intercept MD source interface.
- The Management Ethernet interface is part of its own VRF.

## Gigabit Ethernet Port Numbering

The Gigabit Ethernet Management port is always GigabitEthernet0.

In a dual SUP configuration, the Management Ethernet interface on the active SUP will always be Gigabit Ethernet 0, while the Management Ethernet interface on the standby SUP will not be accessible using the Cisco IOS-XE CLI in the same telnet session. The standby SUP can be telnetted to through the console port, however.

The port can be accessed in configuration mode like any other port on the Cisco cBR Series Routers:

```
Router#configure terminal  
Enter configuration commands, one per line. End with CNTL/Z.  
Router(config)#interface gigabitethernet0  
Router(config-if)#
```

## IP Address Handling in ROMMON and the Management Ethernet Port

Assuming the IOS-XE process has not begun running on the Cisco cBR Series Router, the IP address that was set in ROMMON acts as the IP address of the Management Ethernet interface. In cases where the IOS-XE process is running and has taken control of the Management Ethernet interface, the IP address specified when configuring the Gigabit Ethernet 0 interface in the IOS-XE CLI becomes the IP address of the Management Ethernet interface. The ROMMON-defined IP address is only used as the interface address when the IOS-XE process is inactive.

For this reason, the IP addresses specified in ROMMON and in the IOS-XE CLI can be identical and the Management Ethernet interface will function properly in single SUP configurations.

In dual SUP configurations, however, users should never configure the IP address in the ROMMON on either SUP0 or SUP1 to match each other or the IP address as defined by the IOS-XE CLI. Configuring matching

IP addresses introduces the possibility for an active and standby Management Ethernet interface having the same IP address with different MAC addresses, which will lead to unpredictable traffic treatment.

## Gigabit Ethernet Management Interface VRF

Placing the management Ethernet interface in its own VRF has the following effects on the Management Ethernet interface:

- Many features must be configured or used inside the VRF, so the CLI may be different for certain Management Ethernet functions on the Cisco cBR Series Routers than on Management Ethernet interfaces on other routers.
- The VRF prevents route leakage and avoids unnecessary traffic through the management port.

The Management Ethernet interface VRF supports both IPv4 and IPv6 address families.

## Common Ethernet Management Tasks

Because users can perform most tasks on a router through the Management Ethernet interface, many tasks can be done by accessing the router through the Management Ethernet interface.

This section documents tasks that might be common or slightly tricky on the Cisco cBR Series Routers. It is not intended as a comprehensive list of all tasks that can be done using the Management Ethernet interface.

## Viewing the VRF Configuration

The VRF configuration for the Management Ethernet interface is viewable using the **show running-config vrf** command.

This example shows the default VRF configuration:

```
Router# show running-config vrf
Building configuration...

Current configuration : 351 bytes
vrf definition Mgmt-intf
!
address-family ipv4
exit-address-family
!
address-family ipv6
exit-address-family
!
(some output removed for brevity)
```

# Setting a Default Route in the Management Ethernet Interface VRF

To set a default route in the Management Ethernet Interface VRF, use the **ip route vrf Mgmt-intf 0.0.0.0 0.0.0.0 next-hop-IP-address** command.

## Setting the Management Ethernet IP Address

The IP address of the Management Ethernet port is set like the IP address on any other interface.

Below are two simple examples of configuring an IPv4 address and an IPv6 address on the Management Ethernet interface.

### IPv4 Example

```
Router(config)# interface GigabitEthernet 0
Router(config-if)# ip address A.B.C.D A.B.C.D
```

### IPv6 Example

```
Router(config)# interface GigabitEthernet 0
Router(config-if)# ipv6 address X:X:X:X::X /prefix-length
```

## Telnetting over the Management Ethernet Interface

Telnetting can be done through the VRF using the Management Ethernet interface.

In the following example, the router telnets to 172.17.1.1 through the Management Ethernet interface VRF:

```
Router# telnet 172.17.1.1 /vrf Mgmt-intf
```

## Pinging over the Management Ethernet Interface

Pinging other interfaces using the Management Ethernet interface is done through the VRF.

In the following example, the router pings the interface with the IP address of 172.17.1.1 through the Management Ethernet interface:

```
Router# ping vrf Mgmt-intf 172.17.1.1
Type escape sequence to abort.
Sending 5, 100-byte ICMP Echos to 172.17.1.1, timeout is 2 seconds:
.!!!!
Success rate is 80 percent (4/5), round-trip min/avg/max = 1/1/1 ms
```

## Copy Using TFTP or FTP

To copy a file using TFTP through the Management Ethernet interface, the **ip tftp source-interface GigabitEthernet 0** command must be entered before entering the **copy tftp** command because the **copy tftp** command has no option of specifying a VRF name.

Similarly, to copy a file using FTP through the Management Ethernet interface, the **ip ftp source-interface GigabitEthernet 0** command must be entered before entering the **copy ftp** command because the **copy ftp** command has no option of specifying a VRF name.

### TFTP Example

```
Router(config)# ip tftp source-interface gigabitethernet 0
```

### FTP Example

```
Router(config)# ip ftp source-interface gigabitethernet 0
```

## NTP Server

To allow the software clock to be synchronized by a Network Time Protocol (NTP) time server over the Management Ethernet interface, enter the **ntp server vrf Mgmt-intf** command and specify the IP address of the device providing the update.

The following CLI provides an example of this procedure.

```
Router(config)# ntp server vrf Mgmt-intf 172.17.1.1
```

## SYSLOG Server

To specify the Management Ethernet interface as the source IP or IPv6 address for logging purposes, enter the **logging host ip-address vrf Mgmt-intf** command.

The following CLI provides an example of this procedure.

```
Router(config)# logging host ip-address vrf Mgmt-intf
```

## SNMP-Related Services

To specify the Management Ethernet interface as the source of all SNMP trap messages, enter the **snmp-server source-interface traps gigabitEthernet 0** command.

The following CLI provides an example of this procedure:

```
Router(config)# snmp-server source-interface traps gigabitEthernet 0
```

## Domain Name Assignment

The IP domain name assignment for the Management Ethernet interface is done through the VRF.



To define the default domain name as the Management Ethernet VRF interface, enter the **ip domain-name vrf Mgmt-intf domain** command.

```
Router(config)# ip domain-name vrf Mgmt-intf cisco.com
```

## DNS service

To specify the Management Ethernet interface VRF as a name server, enter the **ip name-server vrf Mgmt-intf IPv4/IPv6 address** command.

## RADIUS or TACACS+ Server

To group the Management VRF as part of a AAA server group, enter the **ip vrf forward Mgmt-intf** command when configuring the AAA server group.

The same concept is true for configuring a TACACS+ server group. To group the Management VRF as part of a TACACS+ server group, enter the **ip vrf forwarding Mgmt-intf** command when configuring the TACACS+ server group.

### RADIUS Server Group Configuration

```
Router(config)# aaa group server radius hello
Router(config-sg-radius)# ip vrf forwarding Mgmt-intf
```

### TACACS+ Server Group Configuration

```
Router(config)# aaa group server tacacs+ hello
Router(config-sg-tacacs)# ip vrf forwarding Mgmt-intf
```

## VTY lines with ACL

To ensure an access control list (ACL) is attached to vty lines that are and are not using VRF, use the **vrf-also** option when attaching the ACL to the vty lines.

```
Router(config)# line vty 0 4
Router(config-line)#access-class 90 in vrf-also
```

## Configuring the AUX Port for Network Management

- 
- Step 1** AUX port is used for IOSd command prompt. Type the **set** command at the rommon prompt.
- Step 2** Verify if **BOOT\_PARAM** is defined. It must not be defined.
- Step 3** If the **BOOT\_PARAM** is defined, do the following:
- Type **unset BOOT\_PARAM**.
  - Type **sync**.
  - Type **reset**.

**Step 4** Boot with the latest image. The AUX port will show IOS command prompt.

## Preprovisioning the Supervisor in the Cisco cBR Chassis

Preprovisioning on the Cisco cBR allows you to configure the Supervisors without their physical presence in the chassis.

### Procedure

	Command or Action	Purpose
<b>Step 1</b>	<b>enable</b> <b>Example:</b> Router> <b>enable</b>	Enables privileged EXEC mode. Enter your password if prompted.
<b>Step 2</b>	<b>configure terminal</b> <b>Example:</b> Router# <b>configure terminal</b>	Enters global configuration mode.
<b>Step 3</b>	<b>card slot/1 sup-pic-8x10g</b> <b>Example:</b> Router(config)# <b>card 4/1 sup-pic-8x10g</b>	Preprovisions the Supervisor in the Cisco cBR chassis. <ul style="list-style-type: none"> <li><i>slot</i>—Identifies the chassis slot number for the Supervisor PIC. The valid values are 4 and 5.</li> </ul>

## Configuring the Gigabit Ethernet Interface for Network Management

You must configure the GigabitEthernet0 interface and enable it to use the NME port.

### Procedure

	Command or Action	Purpose
<b>Step 1</b>	<b>enable</b> <b>Example:</b> Router> <b>enable</b>	Enables privileged EXEC mode. Enter your password if prompted.
<b>Step 2</b>	<b>configure terminal</b> <b>Example:</b> Router# <b>configure terminal</b>	Enters global configuration mode.
<b>Step 3</b>	<b>interface GigabitEthernet0</b> <b>Example:</b> Router(config)# <b>interface GigabitEthernet0</b>	Enters the Gigabit Ethernet interface configuration mode.

	Command or Action	Purpose
Step 4	<b>vrf forwarding</b> <i>vrf-name</i> <b>Example:</b> Router(config-if) # <b>vrf forwarding</b> Mgmt-intf	Associates a Virtual Routing and Forwarding (VRF) instance with the interface. <ul style="list-style-type: none"> <li>• <i>vrf-name</i>—The interface name to be associated with the specified VRF.</li> </ul>
Step 5	<b>ip address</b> <i>ip-address subnet-mask</i> <b>Example:</b> Router(config-if) # <b>ip address</b> 192.71.0.1 255.255.255.0	Sets the IP address of the Gigabit Ethernet interface. <ul style="list-style-type: none"> <li>• <i>ip-address</i>—IP address of the Gigabit Ethernet interface.</li> <li>• <i>subnet -mask</i>—Subnet mask for the network.</li> </ul>
Step 6	<b>no shutdown</b> <b>Example:</b> Router(config-if) # <b>no shutdown</b>	Enables the Gigabit Ethernet interface.
Step 7	<b>speed 1000</b> [ <b>negotiate</b> ] <b>Example:</b> Router(config-if) # <b>speed 1000</b>	Configures the speed for the Gigabit Ethernet interface.
Step 8	<b>duplex full</b> <b>Example:</b> Router(config-if) # <b>duplex full</b>	Configures full duplex operation on the Gigabit Ethernet interface.
Step 9	<b>negotiation auto</b> <b>Example:</b> Router(config-if) # <b>negotiation auto</b>	Selects the auto-negotiation mode.
Step 10	<b>end</b> <b>Example:</b> Router(config-if) # <b>end</b>	Exits Gigabit Ethernet interface configuration mode. Returns to privileged EXEC mode.

## Configuring the DTI Port on the Supervisor PIC

The Cisco cBR router can run in standalone mode, which uses internal clock and does not require any external reference clock source. The Cisco cBR router also supports DTI server as an external clocking source. To use a DTI server as a reference clock source, you must enable the DTI port on the Supervisor PIC.

### Procedure

	Command or Action	Purpose
Step 1	<b>enable</b> <b>Example:</b>	Enables privileged EXEC mode. Enter your password if prompted.

	Command or Action	Purpose
	<code>Router&gt; enable</code>	
<b>Step 2</b>	<b>configure terminal</b> <b>Example:</b> <code>Router# configure terminal</code>	Enters global configuration mode.
<b>Step 3</b>	<b>cable clock dti</b> <b>Example:</b> <code>Router(config)# cable clock dti</code>	Configures the DTI clock reference mode for the Supervisor PIC.

## Configuring the TenGigabit Ethernet Interface for Network Management

You must configure the TenGigabitEthernet interface and enable it to use the NME port.

### Procedure

	Command or Action	Purpose
<b>Step 1</b>	<b>enable</b> <b>Example:</b> <code>Router&gt; enable</code>	Enables privileged EXEC mode. Enter your password if prompted.
<b>Step 2</b>	<b>configure terminal</b> <b>Example:</b> <code>Router# configure terminal</code>	Enters global configuration mode.
<b>Step 3</b>	<b>interface TenGigabitEthernet</b> <b>Example:</b> <code>Router(config)# interface TenGigabitEthernet4/1/0</code>	Enters the TenGigabit Ethernet interface configuration mode.
<b>Step 4</b>	<b>ip address <i>ip-address subnet-mask</i></b> <b>Example:</b> <code>Router(config-if)# ip address 1.2.3.4 255.255.255.0</code>	Sets the IP address of the TenGigabit Ethernet interface.
<b>Step 5</b>	<b>load-interval <i>seconds</i></b> <b>Example:</b> <code>Router(config-if)# load-interval 30</code>	Changes the length of time for which data is used to compute load statistics.
<b>Step 6</b>	<b>no shutdown</b> <b>Example:</b> <code>Router(config-if)# no shutdown</code>	Enables the TenGigabit Ethernet interface.

	Command or Action	Purpose
Step 7	<b>end</b> <b>Example:</b> Router(config-if) # <b>end</b>	Exits TenGigabit Ethernet interface configuration mode. Returns to privileged EXEC mode.

## Connecting the New Router to the Network

Connect the new router to the network using a n Ethernet interface. After the router successfully resolves its host name, new router sends a TFTP broadcast requesting the file name-config or name.cfg. The router name must be in all lowercase, even if the true host name is not. The file is downloaded to the new router, where the configuration commands take effect immediately. If the configuration file is complete, the new router should be fully operational.

To save the complete configuration to NVRAM, use the following commands in privileged EXEC mode:

### Procedure

	Command or Action	Purpose
Step 1	<b>enable password</b>	Enters privileged mode on the new router.
Step 2	<b>copy running-config startup-config</b>	<p>Saves the information from the name-config file into your startup configuration. On most platforms, this step saves the configuration to NVRAM.</p> <p><b>Note</b> Verify that the existing and new routers (or access servers) are connected before entering the <b>copy running-config startup-config</b> EXEC command to save configuration changes. Use the <b>ping</b> EXEC command to verify connectivity. If an incorrect configuration file is downloaded, the new router will load NVRAM configuration information before it can enter AutoInstall mode.</p> <p>If the configuration file is a minimal configuration file, the new router comes up, but with only one interface operational. Use the following commands to connect to the new router and configure it.</p>
Step 3	<b>telnet existing</b>	Establishes a Telnet connection to the existing router.
Step 4	<b>telnet newrouter</b>	From the existing router, establishes a Telnet connection to the new router.
Step 5	<b>enable password</b>	Enters privileged EXEC mode.
Step 6	<b>setup</b>	Enters setup mode to configure the new router.

## Setting Password Protection on the Cisco CMTS



**Note** For security purposes, the EXEC has two levels of access to commands: user EXEC mode and privileged EXEC mode. The commands available at the user level are a subset of those available at the privileged level.



**Tip** Because many privileged-level EXEC commands are used to set operating parameters, password-protect these commands to prevent unauthorized use.



**Note** An enable secret password can contain from 1 to 25 uppercase and lowercase alphanumeric characters. An enable password can contain any number of uppercase and lowercase alphanumeric characters. A number cannot be the first character. Spaces are valid password characters; for example, “two words” is a valid password. Leading spaces are ignored. Trailing spaces are recognized. Alphanumeric characters are recognized as uppercase or lowercase.

Passwords should be different for maximum security. If you enter the same password for both during the setup script, the system accepts it, but you receive a warning message indicating that you should enter a different password.

At the EXEC prompt, enter one of the following two commands to set password protection:

- **enable secret password**—a very secure encrypted password.
- **enable**—is a less secure and nonencrypted password.

To gain access to privileged-level commands, enter the desired password.

## Recovering Lost Password on the Cisco CMTS

Complete the following steps to recover or replace a lost enable, enable secret, or console login password:

- 
- Step 1** Attach an ASCII terminal to the console port on your Cisco CMTS.
- Step 2** Configure the terminal to operate at 9600 baud, 8 data bits, no parity, and 1 stop bits.
- Step 3** If you can log in to the router as a nonprivileged user, enter the **show version** command to display the existing configuration register value. Note the value for later use. If you cannot log in to the router at all, continue with the next step.
- Step 4** Press the **Break** key or send a **Break** from the console terminal.
- If Break is enabled, the router enters the ROM monitor, indicated by the ROM monitor prompt (rommon n>), where n is the number of the command line. Proceed to configuring the register.
  - If Break is disabled, power cycle the router (turn the router off or unplug the power cord, and then restore power). Within 60 seconds of restoring the power to the router, press the **Break** key or send a **Break**. This action causes the router to enter the ROM monitor and display the ROM monitor prompt (rommon 1>).

- Step 5** To set the configuration register on a Cisco CMTS, use the configuration register utility by entering the **confreg** command at the ROM monitor prompt as follows:

```
rommon 1> confreg
```

Answer **yes** to the *enable ignore system config info?* prompt and note the current configuration register settings.

- Step 6** Initialize the router by entering the **reset** command as follows:

```
rommon 2> reset
```

The router initializes, the configuration register is set to 0x142, the router boots the system image from Flash memory and enters the System Configuration dialog (setup), as follows:

```
--- System Configuration Dialog ---
```

- Step 7** Enter **no** in response to the System Configuration dialog prompts until the following message appears:

```
Press RETURN to get started!
```

- Step 8** Press **Return**. The user EXEC prompt appears as follows:

```
Router>
```

- Step 9** Enter the **enable** command to enter privileged EXEC mode.

- Step 10** Enter the **show startup-config** command to display the passwords in the configuration file as follows:

```
Router# show startup-config
```

- Step 11** Scan the configuration file display looking for the passwords; the enable passwords are usually near the beginning of the file, and the console login or user EXEC password is near the end. The passwords displayed will look something like this:

```
enable secret 5 $1$ORPP$s9syZt4uKn3SnpuLDrhuei
enable password 23skiddoo
:
:
line con 0
 password onramp
```

**Note** The enable secret password is encrypted and cannot be recovered; it must be replaced. The enable and console passwords can be encrypted text or clear text.

Proceed to the next step to replace an enable secret, console login, or enable password. If there is no enable secret password, note the enable and console login passwords if they are not encrypted and proceed to set the configuration register to the original value.

**Caution** Do not perform the next step unless you have determined that you must change or replace the enable, enable secret, or console login passwords. Failure to follow the steps as presented here could cause your router configuration to be erased.

- Step 12** (Optional) Enter the configure memory command to load the startup configuration file into running memory. This action allows you to modify or replace passwords in the configuration.

```
Router# configure memory
```

- Step 13** Enter the **configure terminal** command for configuration mode:

```
Router# configure terminal
```

**Step 14** To change all three passwords, enter the following commands:

```
Router(config)# enable secret newpassword1  
Router(config)# enable password newpassword2  
Router(config)# line con 0  
  
Router(config)# password newpassword3
```

Change only the passwords necessary for your configuration. You can remove individual passwords by using the **no** form of the previous commands. For example, entering the **no enable secret** command removes the enable secret password.

**Step 15** You must configure all interfaces to not be administratively shut down as follows:

```
Router(config)# interface gigabitethernet 0  
  
Router(config)# no shutdown
```

Enter the equivalent commands for all interfaces that were originally configured. If you omit this step, all interfaces are administratively shut down and unavailable when the router is restarted.

**Step 16** Use the **config-register** command to set the configuration register to the original value noted earlier.

**Step 17** Press **Ctrl-Z** or type **end** to exit configuration mode:

```
Router(config)# end
```

**Caution** Do not perform the next step unless you have changed or replaced a password. If you skipped changing or replacing the enable, enable secret, or console login passwords previously, then proceed now to reload. Failure to observe this sequence causes the system to erase your router configuration file.

**Step 18** Enter the **copy running-config startup-config** command to save the new configuration to nonvolatile memory:

```
Router# copy running-config startup-config
```

**Step 19** Enter the **reload** command to reboot the router:

```
Router# reload
```

**Step 20** Log in to the router with the new or recovered passwords.

---

## Saving Your Configuration Settings

To store the configuration or changes to your startup configuration in NVRAM, enter the **copy running-config startup-config** command at the *Router#* prompt.

This command saves the configuration settings you set using configuration mode, the Setup facility, or AutoInstall.





---

**Note** If you do not save your settings, your configuration will be lost the next time you reload the router.

---

### Example

```
Router# copy running-config startup-config
```

## Reviewing Your Settings and Configurations

- To view the current configuration of a Cisco CMTS, run the **show running-config** command at the command-line interface (CLI) prompt in EXEC mode or privileged EXEC mode.
- To review changes you make to the configuration, use the EXEC **show startup-config** command to display the information stored in NVRAM.

## Recovering Unresponsive Modems

If the cable modem does not respond to pings from the Cisco Converged Broadband Router, the modem DSBG, DSID, and the BPI index values on the Cisco Converged Broadband Router may be incorrect. To recover the unresponsive modem, run the **cable reconciliation enable** command to generate the correct DSBG, DSID, and the BPI index values. The following CLI provides an example of this procedure:

```
Router# configure terminal
Router# cable reconciliation enable
Router# end
```

To set the time when the **cable reconciliation enable** command should run, run the **cable reconciliation time hours** command, where *hours* is the time in the 24 hour format. The following CLI provides an example of this procedure:

```
Router# configure terminal
Router# cable reconciliation time 23
Router# end
```





## CHAPTER 2

# Cisco Smart Licensing

---

A new licensing model, based on a single technology, has been designed for Cisco called Smart Licensing that is intended to provide Enterprise Level Agreement-like capabilities for all Cisco products. The Cisco Smart Licensing is based on the Trust but Verify model.

Your software release may not support all the features that are documented in this module. For the latest feature information and caveats, see the release notes for your platform and software release. The Feature Information Table at the end of this document provides information about the documented features and lists the releases in which each feature is supported.

Use Cisco Feature Navigator to find information about platform support and Cisco software image support. To access Cisco Feature Navigator, go to <http://tools.cisco.com/ITDIT/CFN/>. An account on <http://www.cisco.com/> is not required.

### Contents

- [Hardware Compatibility Matrix for the Cisco cBR Series Routers, on page 39](#)
- [Prerequisites for Cisco Smart Licensing, on page 40](#)
- [Information About Cisco Smart Licensing, on page 41](#)
- [How to Configure Cisco Smart Licensing, on page 43](#)
- [How to Configure Cisco Smart Licensing using Transport Gateway Solution, on page 54](#)
- [Configuring 100G Licenses for Supervisor 250G, on page 56](#)
- [Verifying Cisco Smart Licensing Configuration, on page 61](#)
- [Troubleshooting Cisco Smart Licensing, on page 67](#)
- [Flexible Consumption Model \(FCM\) Licenses, on page 68](#)
- [Additional References, on page 73](#)
- [Feature Information for Cisco Smart Licensing, on page 73](#)

## Hardware Compatibility Matrix for the Cisco cBR Series Routers



---

**Note** The hardware components that are introduced in a given Cisco IOS-XE Release are supported in all subsequent releases unless otherwise specified.

---

Table 3: Hardware Compatibility Matrix for the Cisco cBR Series Routers

Cisco CMTS Platform	Processor Engine	Interface Cards
Cisco cBR-8 Converged Broadband Router	<p><b>Cisco IOS-XE Release 16.5.1 and Later Releases</b></p> <p>Cisco cBR-8 Supervisor:</p> <ul style="list-style-type: none"> <li>• PID—CBR-SUP-250G</li> <li>• PID—CBR-CCAP-SUP-160G</li> </ul>	<p><b>Cisco IOS-XE Release 16.5.1 and Later Releases</b></p> <p>Cisco cBR-8 CCAP Line Cards:</p> <ul style="list-style-type: none"> <li>• PID—CBR-LC-8D30-16U30</li> <li>• PID—CBR-LC-8D31-16U30</li> <li>• PID—CBR-RF-PIC</li> <li>• PID—CBR-RF-PROT-PIC</li> <li>• PID—CBR-CCAP-LC-40G</li> <li>• PID—CBR-CCAP-LC-40G-R</li> <li>• PID—CBR-CCAP-LC-G2-R</li> <li>• PID—CBR-SUP-8X10G-PIC</li> <li>• PID—CBR-2X100G-PIC</li> </ul> <p>Digital PICs:</p> <ul style="list-style-type: none"> <li>• PID—CBR-DPIC-8X10G</li> <li>• PID—CBR-DPIC-2X100G</li> </ul> <p>Cisco cBR-8 Downstream PHY Module:</p> <ul style="list-style-type: none"> <li>• PID—CBR-D31-DS-MOD</li> </ul> <p>Cisco cBR-8 Upstream PHY Modules:</p> <ul style="list-style-type: none"> <li>• PID—CBR-D31-US-MOD</li> </ul>



**Note** Do not use DPICs (8X10G and 2x100G) to forward IP traffic, as it may cause buffer exhaustion, leading to line card reload.

The only allowed traffic on a DPIC interface is DEPI, UEPI, and GCP traffic from the Cisco cBR-8 router to Remote PHY devices. Other traffic such as DHCP, SSH, and UTSC should flow via another router, since DPICs cannot be used for normal routing.

## Prerequisites for Cisco Smart Licensing

- You must configure the DNS server using the **ip name-server** global configuration command.

- You must configure the IP DNS-based hostname-to-address translation using the **ip domain-lookup** global configuration command.
- Cisco Smart Licensing is enabled by default on the Cisco cBR router. However, you must ensure that the CiscoTAC-1 call-home profile points to the Cisco Smart Software Manager at the following URL using the **show call-home profile CiscoTAC-1** command:

<https://tools.cisco.com/its/service/oddce/services/DDCEService>

The following is a sample output of the **show call-home profile CiscoTAC-1** command:

```
Router# show call-home profile CiscoTAC-1

Load for five secs: 10%/1%; one minute: 9%; five minutes: 8%
Time source is NTP, 16:49:35.525 PDT Thu Oct 29 2015

Profile Name: CiscoTAC-1
  Profile status: ACTIVE
  Profile mode: Anonymous Reporting Only
  Reporting Data: Smart Call Home, Smart Licensing
  Preferred Message Format: xml
  Message Size Limit: 3145728 Bytes
  Transport Method: http
  Email address(es): callhome@cisco.com
  HTTP address(es): https://tools.cisco.com/its/service/oddce/services/DDCEService

Periodic configuration info message is scheduled every 19 day of the month at 11:41

Periodic inventory info message is scheduled every 19 day of the month at 11:26

Alert-group          Severity
-----
crash                debug
diagnostic           minor
environment          minor
inventory            normal

Syslog-Pattern      Severity
-----
.*                  major
```

- Ensure that you can ping the DNS server. If you are unable to ping the server, verify the connectivity to the NME port on the Cisco cBR router.



---

**Note** If you are using a Virtual Routing and Forwarding (VRF) instance, ensure that you can ping the VRF instance.

---

## Information About Cisco Smart Licensing

Cisco Smart Licensing is software-based licensing that consists of tools and processes to authorize the customers for the usage and reporting of the Cisco products. The feature has the capability to capture the customer order and communicate with the Cisco Cloud License Service through Smart Call Home transport media or through Smart Transport to complete the product registration and authorization. If the Cisco products stop

communicating with the Cisco Cloud License Service for 90 days, the cable interfaces in the Cisco products will be locked, which means the customer can no longer enable/disable the cable interfaces.

The Cisco Smart Licensing feature is aimed at giving users an experience of a single, standardized licensing solution for all Cisco products.

In the Cisco Smart Licensing Model, you can activate licensed features (also known as entitlements) without the use of a special software key or upgrade license file. You can activate the new functionality using the appropriate product commands and configurations and the functionality is activated. A software reboot is not required for the Cisco cBR router.

The Cisco cBR router supports software activation using Cisco Smart Licensing. The Cisco Smart Licensing is enabled by default on the Cisco cBR router.



---

**Note** The **no http secure server-identity-check** option was default in versions 16.7.2 and earlier, and was not configurable. Ensure that you configure the **no http secure server-identity-check** option after upgrading to maintain parity with images earlier than 16.7.3. The default option is **http secure server-identity-check**. A LCHA license is needed for each working linecard that is protected by the protect linecard.

---

## Downstream License

The DOCSIS 3.1 license scheme provides support to identify the DOCSIS 3.1 channels and their width. The DOCSIS 3.1 entitlement is DOCSIS 3.1 Downstream Channel License.



---

**Note** Configuration of DOCSIS 3.1 Downstream OFDM channel consumes both DOCSIS 3.0 and DOCSIS 3.1 license in a 1:1 ratio with license units of 6 MHz.

---

## Out of Compliance Enforcement

The following two events are responsible for triggering a DOCSIS configuration lock enforcement.

### Eval-Expired (Evaluation Period Expired)

When a router is not registered with Smart License Manager for more than ninety days.

### Auth-Expired (authorization Period Expired)

When a registered router fails to communicate with the Smart License Manager for more than ninety days.

When either of the above mentioned events occur, the Smart Agent sends a notification to the platform. The platform, upon receiving such notification, **locks** the following CLI commands:

- **[no] cable upstream shutdown** *upstream-port-number*
- **contoller upstream-cable** *slot/subslot/controller-port-number*
- **rf-channel-number**

Any attempt to configure the above mentioned CLIs in this condition would fail and a warning message will be displayed. Under this condition all other CLIs are configurable, some of which may be required to configure Cisco License Call Home, connect to cisco and register the device to come out of either of the above two events and enter into authorized or Out of Compliance (OOC) state.

You can copy the modified configuration file to the startup configuration file and reload the device to make that configuration effective. However, when the device is in enforced state, you can only copy the running configuration file to the startup configuration file.



---

**Note** Any attempt to copy any other file fails and a warning message is displayed.

---

## How to Configure Cisco Smart Licensing

This section contains the following:

### Using Cisco Smart Licensing Agent on the Router

---

**Step 1** Set up a Cisco Smart Account. See [Setting Up a Cisco Smart Account, on page 43](#).

**Step 2** Log in to the [Cisco Smart Software Manager](#).

**Step 3** (Optional) Create a virtual account. See [Creating Virtual Accounts, on page 50](#).

**Note** A single default virtual account is always available.

**Step 4** Create a product instance registration token. See [Creating a Product Instance Registration Token, on page 51](#).

**Step 5** Register the router with the Cisco Licensing Cloud using the product instance registration token. See [Registering the Router with the Cisco Licensing Cloud Using the Registration Token, on page 53](#).

**Step 6** Log in to the [Cisco Smart Software Manager](#) for managing licenses.

For more information, see the *Cisco Smart Software Manager User Guide*, which is accessible from the Cisco Smart Software Manager tool.

---

### Setting Up a Cisco Smart Account

Cisco Smart Account enables you to fully utilize the license management features of the smart-enabled products.

#### Before you begin

- Ensure that you have a CCO ID.
- 

**Step 1** Log in to [Cisco Software Workspace](#) (CSW) with your CCO ID.

**Step 2** Hover the cursor over the *Administration* tab and click **Create Smart Accounts**.

Figure 2: Creating Smart Account



**Step 3** Perform one of the following to select the Account Approver:

- To select yourself as the Approver, click the **Yes, I will be the Approver for the account** radio button.
- To select other person as the Approver, click the **No, the person specified below will be the Approver for the account** radio button and specify the person's e-mail ID.

**Note** The specified Approver must have the authority to enter legal agreements. The Approver serves as the primary owner and nominates account administrators.

Figure 3: Selecting the Approver

**Step 4** If you are the Approver, perform the following:

- Enter the Account Name, Company/Organization Name, Country, and State/Province/Region information.
- (Optional) Click **Edit**. In the *Edit Account Identifier* window, enter a valid Proposed Domain Identifier and Contact Phone Number. Click **OK**.

**Note** The default domain identifier is the Approver e-mail domain. If you edit the domain identifier, the change goes through a manual approval process.



- c) Click **Continue** to select the legal address to be linked to your Cisco Smart Account.

**Figure 4: Setting Up Account Information When You Are The Approver**

The screenshot shows the 'Account Information' page with the following details:

- Account Domain Identifier:** test.big-u.edu (with an 'Edit' link)
- Account Name:** big-u.edu
- Buttons:** Continue

The 'Edit Account Identifier' dialog box contains:

- Text:** This Account Domain Identifier is generated based on the domain of the primary email address in your Cisco.com profile and will need to undergo an approval process if you change it. Cisco will contact you by telephone to complete this process, so please verify or enter your desired contact phone number below.
- Text:** If you do decide to change the Account Domain Identifier, it must maintain domain format and can include subdomains to the left of the domain, e.g., east.example.com or west.example.com.
- Proposed Domain Identifier:** twister.big-u.edu
- Contact Phone Number:** +1 408-853-1224
- Buttons:** OK, Cancel

**Step 5** If you are not the Approver, perform the following:

- Enter the Account Name and an optional Message to Approver.
- (Optional) Click **Edit**. In the *Edit Account Identifier* window, enter a valid Proposed Domain Identifier. Click **OK**.

**Note** The default domain identifier is the Approver e-mail domain. If you edit the domain identifier, the change goes through a manual approval process.

- c) Click **Continue**.

**Figure 5: Setting Up Account Information When You Are Not The Approver**

The screenshot shows the 'Account Information' page with the following details:

- Account Domain Identifier:** company.com (with an 'Edit' link)
- Account Name:** Company ABC
- Message to Approver:** A text area for entering a message.
- Buttons:** Continue

The 'Edit Account Identifier' dialog box contains:

- Text:** The Account Domain Identifier is generated based on the domain of the approver's email address and will require the Approver to complete an approval process via telephone if you change it.
- Text:** If you do decide to change the Account Domain Identifier, it must maintain domain format and can include subdomains to the left of the domain, e.g., east.example.com or west.example.com.
- Proposed Domain Identifier:** (Empty field)
- Error Message:** Please enter a valid domain, i.e. example.com or west.example.com
- Buttons:** OK, Cancel

**Step 6** If you are not the Approver, the Approver will receive an e-mail and must perform the following:

- Click **Complete Smart Account Setup** in the received e-mail.

Figure 6: Complete Smart Account Setup Link in E-mail

### New Cisco Smart Account - NTT Demo Account (Pending)

A new Cisco Smart Account has been requested for "NTT Demo Account" and you have been designated as an "Approver" for this account. A Smart Account is used for managing your company's relationship with Cisco, including initiatives such as Smart Licensing. This account is currently in a Pending state, as it requires a person designated as an "Approver" to complete the process. Review the Account Summary information below and click the Complete Smart Account Setup link to continue. As a part of this process, you will be asked to accept a Smart Account Agreement. If you'd like to look at the agreement beforehand, you can [preview the agreement](#).

[Complete Smart Account Setup »](#)

**Note:** You will need to log in with a Cisco.com ID. If you don't have one, you will need to [register for a new account](#).

- b) Click the appropriate radio button to accept, decline, or nominate another Approver. To nominate another Approver, enter the person's e-mail address. Click **Continue**.

**Note** If the Approver declines, the Cisco Smart Account is deleted. If the Approver nominates another approver, the new Approver must accept the role.

Figure 7: Accepting the Account Approver Role

**Cisco Software Workspace**  
Smart Accounts

---

**Smart Account Setup**

A Cisco Smart Account has been set up for "NTT Demo Account" and you have been nominated as the Approver for the account. This Smart Account will be used for managing the company's relationship with Cisco, including initiatives such as Smart Licensing. The account is currently in a Pending state and will remain so until the approver completes the setup process.

**Account Approver**

You have been nominated as the Approver for the "NTT Demo Account" Smart Account. Do you accept this role? This person will approve terms and conditions for the account and will be the one completing the account setup process. [Learn More](#)

Yes, I accept the role of Account Approver  
 No, I do not accept the role of Account Approver  
 No, but I nominate the person specified below to be the Account Approver

---

**Account Summary**

Account Domain Identifier: intcsia.com  
 Account Name: NTT Demo Account  
 Requested By: Heather Deng (hdeng@csco.com)

[Continue](#)

- c) After accepting the Approver role, click the appropriate radio button to select the Account Domain Identifier or specify a different Account Domain Identifier.

**Figure 8: Completing the Account Information**

Cisco Software Workspace  
Smart Accounts

### Smart Account Setup

**Account Information**

Below is the information for the company. The Account Domain Identifier is based on the email address of the Approver and must belong to the company that will own this account. [Learn More](#)

Account Domain Identifier:  ntt.com - this was entered by person requesting the account, because it does not match your email address, it will require an approval process with Cisco [Learn More](#)

cisco.com - this is based on the email address in your Cisco.com profile, if you want to change it, you can [Edit your Cisco.com Profile](#)

[Specify a different Account Domain Identifier](#)

Account Name:

Back

d) Enter the Account Name and click **Continue**.

The Approver role is accepted and Cisco Smart Account is pending Account Domain approval.

### Step 7

After the Account Domain is approved, the Approver will receive an e-mail and must perform the following:

a) Click **Complete Smart Account Setup** in the received e-mail.

**Figure 9: Cisco Smart Account Identifier Approved E-mail**

**Cisco Smart Account Identifier Approved - Mail**

The Account Domain Identifier for the Cisco Smart Account Gmail has completed the review process. You can continue the account creation process via the Complete Smart Account Setup link below. As a part of this process, you will be asked to accept a Smart Account Agreement. If you'd like to look at the agreement beforehand, you can [preview the agreement](#).

[Complete Smart Account Setup](#)

**Cisco Smart Account Summary**

Account Domain Identifier:	twister.big-u.edu
Account Name:	big-u.edu
Account Status:	Pending Smart Account Agreement Acceptance
Account Approver:	John Doe(SSLMTester1@mail.com)
Requested by:	John Doe(SSLMTester1@mail.com)

b) Enter the Account Name, Company/Organization Name, Country, and State/Province/Region information.

Figure 10: Completing the Account Information and Company/Organization Information

Cisco Software Workspace  
Smart Accounts

### Smart Account Setup

**Account Information**

The Account Domain Identifier has been approved and the account process can be completed, just a few more steps are required.

Account Domain Identifier: lwater.big-u.edu

\* Account Name: big-u.edu

**Company/Organization Information**

Enter information about the company that will own the account. This information will be used in the next step to search for the company or organization's **primary address** in Cisco's customer database.

\* Company/Organization Name: Big U

\* Country: United States

State/Province/Region: California

Continue

- c) Click **Continue** to select the legal address to be linked to the Cisco Smart Account.
- d) Select the Company/Organization Primary Address using the Refine Search option and click **Continue**.

Figure 11: Selecting the Company/Organization Primary Address

Cisco Software Workspace  
Smart Accounts

### Smart Account Setup

In order to validate the identity of the new account, Cisco requires that the account be associated with an existing primary address in its customer database. All matching results are displayed below but only primary addresses can be associated with the Smart Account.

Select Company/Organization Primary Address: [Refine Search](#)

\* Company/Organization Name: Big U

\* Country: United States

Address: Street address where company is headquartered

City: City where the company is headquartered

State/Province/Region: Arizona

Search

Big U 170 W TASMAN DR, SAN JOSE, CA, UNITED STATES — [Primary Address]

Big U FOR US INTERNAL DEMO EVAL ONLY 2601 BRANARD RD BLDG 0 57305, FORT HUACHUCA, AZ, UNITED STATES

Big U FOR US INTERNAL DEMO EVAL ONLY 3133 N MADERA MESA PL, TUCSON, AZ, UNITED STATES

- e) (Optional) Enter the e-mail addresses of the Additional Account Approvers and Additional Account Administrators. The initial Approver automatically becomes an Administrator. Additional Administrators can be created or assigned separately from the Approver creation process.

Figure 12: Nominating Additional Account Approvers and Administrators

Cisco Software Workspace  
Smart Accounts

## Smart Account Setup

**Additional Account Approvers**

You will be an Approver for this account, but you can also nominate other persons to act as Approvers. [Learn More](#)

Additional Approvers:

**Additional Account Administrators**

You will be an Administrator for this account, but you can also nominate other persons to act as Administrators. [Learn More](#)

Account Administrators:

- f) Click **Continue**.
- g) Review the agreement and check the **I agree to the terms above** check box to accept.
- h) Click **Accept and Create Account** to create the Cisco Smart Account.

Figure 13: Accepting the Agreement and Creating the Cisco Smart Account

Cisco Software Workspace  
Smart Accounts

## Smart Account Setup

**CUSTOMER-C2A-OCT14, v1.0**

**CUSTOMER-C2A - SAMPLE**

The Licensed Software is owned and copyrighted by the Individual Software Vendor. The Software is licensed, not sold, only on the terms of this EULA. Acceptance and installation of the software indicates your acceptance of the terms and conditions of this EULA.

Upon receipt and installation of the software and payment of the license fee, you will acquire the right to use the Software in object code form. You assume responsibility for the selection of the program to achieve your intended results, and for the installation, use and results obtained from the Licensed Software.

In consideration of your acceptance of the terms and conditions combined in this EULA, you are granted a non-exclusive license to use the Licensed Software and the associated documentation for your own needs on one device. You are not licensed to rent, lease, transfer or distribute the Software. You may not allow any third party to access or view the Software for any reason other than to install, you professionally in your business where the software is currently being used.

Title and copyright in the Software, including object code media and documentation, remain with the Individual Software Manufacturer. You may not copy, reproduce or make data transmissions, in whole or in part, except as is necessary for back-up or archival purposes. You may not reverse engineer, translate, disassemble or decompile the Software, in whole or in part.

In the case of some Special Licensed software a fee to use, or continue to use, the Software is payable is charged either quarterly or annually. More information on charge-back costs and how they are applied can be found at Software Charge-Back FAQs - WebEx Social.

The license is effective upon acceptance and installation of the Licensed Software and shall continue until terminated. You may terminate it at any time by uninstalling the Licensed Software. ES&S has the right to terminate this Agreement if you fail to comply with any term or condition of this EULA.

I agree to the terms above

You will receive an e-mail confirming the creation of the Cisco Smart Account.

## Creating Virtual Accounts

This procedure is optional. Virtual accounts are collections of licenses and product instances. You can create virtual accounts in Cisco Smart Software Manager to organize the licenses for your company into logical entities. A single virtual account is available by default.

### Before you begin

Set up a Cisco Smart Account. See [Setting Up a Cisco Smart Account, on page 43](#).

**Step 1** Log in to the [Cisco Smart Software Manager](#).

**Step 2** Click the + (plus) symbol to create a virtual account.

**Figure 14: Creating a Virtual Account**

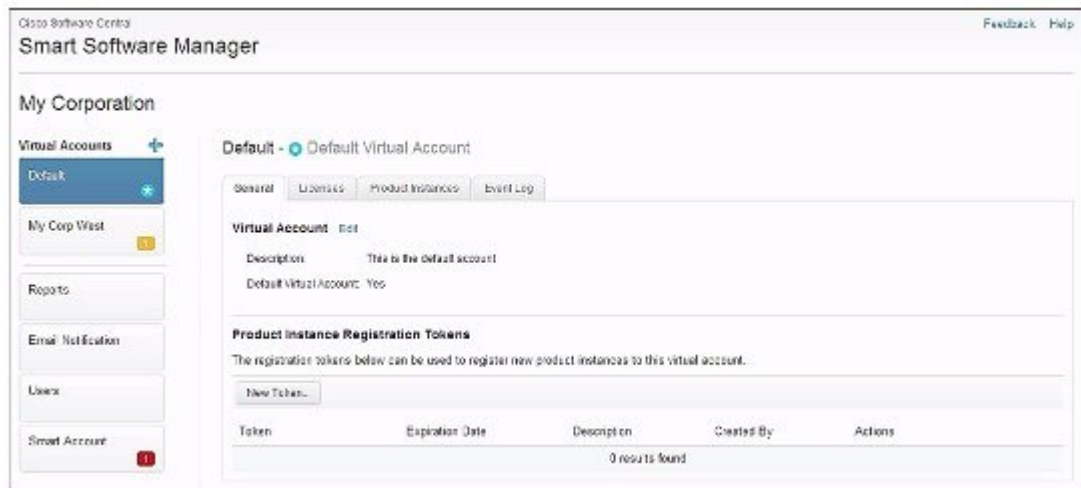

**Step 3** In the **New Virtual Account** dialog box, enter the Name and Description.

**Figure 15: New Virtual Account Dialog Box**

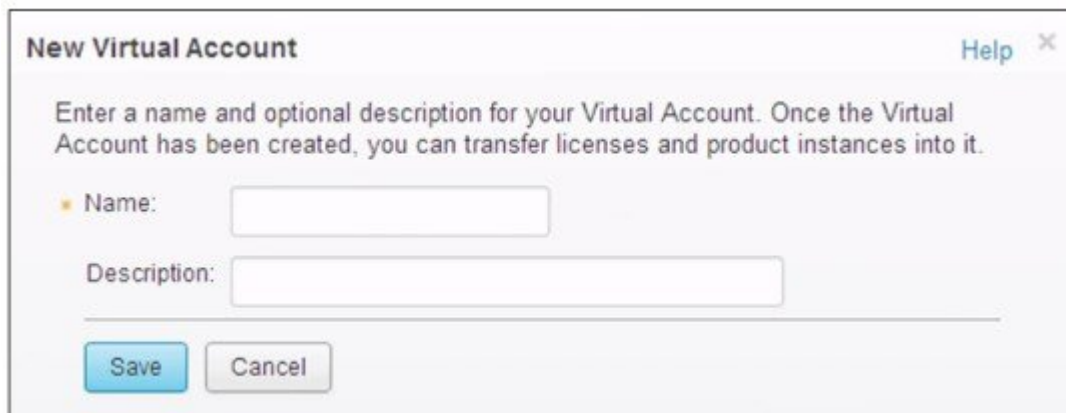

**Step 4** Click **Save**.

## Creating a Product Instance Registration Token

Product instance registration tokens are used to register and consume a product for Cisco Smart Licensing. You must generate a token to register the product and add the product instance to a specified virtual account. Registration tokens can be valid from 1 to 365 days.

**Step 1** Log in to the [Cisco Smart Software Manager](#).

**Step 2** Click an existing virtual account.

**Step 3** In the **General** tab, click **New Token**.

*Figure 16: Creating a New Registration Token*

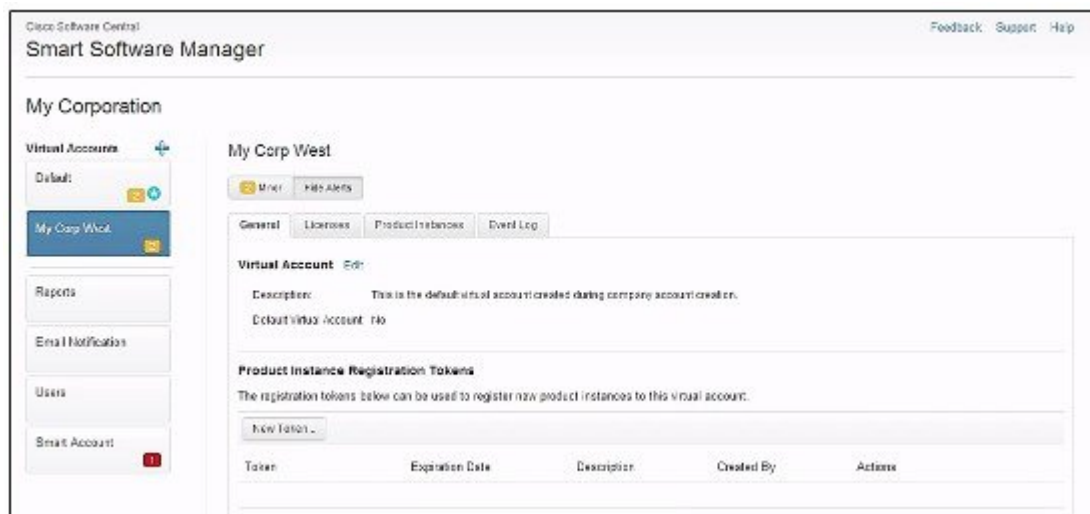

**Step 4** In the **Create Registration Token** dialog box, enter the Description and Expire After information and click **Create Token**.



Figure 17: Create Registration Token Dialog Box

### What to do next

Register the router with the Cisco Licensing Cloud. For more details, see the [Registering the Router with the Cisco Licensing Cloud Using the Registration Token, on page 53](#) section.

## Communication with CSSM

Table 4: Feature History

Feature Name	Release Information	Feature Description
Support for Smart Transport	Cisco IOS XE Dublin 17.12.1	Smart transport is a transport method where a Smart Licensing (JSON) message is contained within an HTTPs message, and exchanged between a product instance and CSSM.  In this release, you can use Smart Transport as the new smart licensing transport, instead of Smart call-home (SCH).

You can configure a product instance to communicate with CSSM in the following ways:

- **Use Smart Call Home (SCH) to communicate with CSSM:** Call Home provides e-mail-based and web-based notification of critical system events. This method of connecting to CSSM is available in the earlier Smart Licensing environment, and remains available with Smart Licensing Using Policy. The following Call Home configuration options are available:
  - **Direct cloud access:** In this method, a product instance sends usage information directly over the internet to CSSM; no additional components are needed for the connection.



- Direct cloud access through an HTTPs proxy: In this method, a product instance sends usage information over the internet through a proxy server - either a Call Home Transport Gateway or an off-the-shelf proxy (such as Apache) to CSSM.
- **Use Smart transport to communicate with CSSM:** Smart transport is a transport method where a Smart Licensing (JSON) message is contained within an HTTPs message, and exchanged between a product instance and CSSM. The following Smart transport configuration options are available:
  - Smart transport: In this method, a product instance uses a specific Smart transport licensing server URL. This must be configured exactly as shown in the workflow section.
  - Smart transport through an HTTPs proxy: In this method, a product instance uses a proxy server to communicate with the licensing server, and eventually, CSSM. The following example shows you how to configure Smart Transport through a HTTP proxy:

```
Router(config)#
Router(config)# license smart proxy address 192.168.0.1
Router(config)# license smart proxy port 3128
```

Ensure that the cBR-8 router can access <https://smartreceiver.cisco.com> to configure Smart Transport. The following example show hot to configure Smart Transport.

```
Router# conf t
license smart url https://smartreceiver.cisco.com/licservice/license
license smart transport smart
end
```



---

**Note** Use the `license smart url` command only if you want to point to a different CSSM. It is not required if you are using using the default cisco official CSSM.

---

## Registering the Router with the Cisco Licensing Cloud Using the Registration Token

The router registration is performed only once for each product instance.



---

**Note** Ensure that you have the product instance registration token.

---

To register the router with the Cisco Licensing Cloud using a registration token, use the following commands:

```
enable
license smart register idtoken id-token
```

For example:

```
Router#license smart register idtoken
YjBkOWM5YTItMDFiOS00ZjBmLTl1Y2YtODEzMzg1YTMzZDVhLTEz
ODE0MjE0%0ANzc5NDF8U1BDUTAySWFRtmJqa1NnbmlzRUIyaG1YU
053L0pHZTNvUW9VTfpE%0AekxCOD0%3D%0A
```

The system contacts the Cisco Smart Licensing servers to obtain authorization for Smart Licensing.

The license agent registers the product with Cisco and receives an identity certificate. This certificate is saved and automatically used for all future communications with Cisco. The license agent automatically renews the registration information with Cisco every 30 days.



**Note** Smart licensing may fail if IPv6 is configured on any interface, and the router does not have IPv6 connectivity to the Internet or Cisco Smart Software Agent (at tools.cisco.com). Log file error messages similar to the following may appear.

(These messages may also appear as a result of other conditions being true.)

```
%SMART_LIC-3-AGENT_REG_FAILED: Smart Agent for Licensing Registration with Cisco licensing
cloud failed: Fail to send out Call Home HTTP message.
%SMART_LIC-3-COMM_FAILED: Communications failure with Cisco licensing cloud: Fail to send
out Call Home HTTP message.
```

If connectivity fails due to this issue, see the [Re-establishing Connectivity to Cisco Smart Call Home Server](#) section.

After connectivity is established, register the router with the Cisco Licensing Cloud.

## Reestablishing Connectivity to Cisco Smart Call Home Server

This section describes what to do when the router fails to connect to the Cisco Smart Call Home Server and IPv6 is configured.

The following scenarios are applicable:

- If the interface is configured using the **ip http client source-interface interface** CLI and has the IPv6 address, the router establishes a session with the remote server with IPv6 connectivity.
- If the interface is configured using the **ip http client source-interface interface** command and has the IPv4 address, the router establishes a session with the remote server with IPv4 connectivity.
- If the interface is configured using **ip http client source-interface interface** command, and has an IPv6 address and an IPv4 address, the router establishes a session with the remote server with IPv6 connectivity.
- If the interface isn't configured using the **ip http client source-interface interface**, the router establishes a session with the remote server with the IPv6 address.

For Cisco IOS XE Everest 16.5.1 or later, if an IPv6 address is available for an interface and the device can't connect to the Internet or Cisco Smart Software Agent, configure the interface to only use IPv4 for smart licensing, by running the following configuration mode command.

```
ip http client source-interface interface
```

## How to Configure Cisco Smart Licensing using Transport Gateway Solution

The steps below describe how to configure Cisco smart licensing using transport gateway solution.

## Procedure

	Command or Action	Purpose
Step 1	<b>enable</b> <b>Example:</b> Router> <b>enable</b>	Enables privileged EXEC mode. <ul style="list-style-type: none"> <li>• Enter your password if prompted.</li> </ul>
Step 2	<b>configure terminal</b> <b>Example:</b> Router# <b>configure terminal</b>	Enters global configuration mode.
Step 3	<b>crypto pki trustpoint</b> <b>Example:</b> Router(config)# <b>crypto pki trustpoint cisco</b>	Declare the trustpoint that the router should use.
Step 4	<b>enrollment terminal</b> <b>Example:</b> Router(ca-trustpoint)# <b>enrollment terminal</b>	Specify manual cut-and-paste certificate enrollment.
Step 5	<b>revocation-check method</b> <b>Example:</b> Router(ca-trustpoint)# <b>revocation-check none</b>	Check the revocation status of a certificate. Method <b>none</b> means certificate checking is not required.
Step 6	<b>crypto pki authenticate</b> <b>Example:</b> Router(config)# <b>crypto pki authenticate cisco</b>	Authenticate the certification authority.
Step 7	<b>no reporting smart-licensing-data</b> <b>Example:</b> Router(config)# <b>call-home</b> Router(cfg-call-home)# <b>profile CiscoTAC-1</b> Router(cfg-call-home-profile)# <b>no reporting smart-licensing-data</b>	Configure the default profile to not to communicate with tools.cisco.com.
Step 8	<b>destination address http address</b> <b>Example:</b> Router(config)# <b>call-home</b> Router(cfg-call-home)# <b>profile Custom-Profile-1</b> Router(cfg-call-home-profile)# <b>reporting smart-licensing-data</b> Router(cfg-call-home-profile)# <b>destination transport-method http</b> Router(cfg-call-home-profile)# <b>no destination transport-method email</b> Router(cfg-call-home-profile)# <b>destination address http</b> <b>https://TDS.IP.HERE:8443/Transportgateway/services/DeviceRequestHandler</b>	Configure the custom profile to communicate with the transport server, here we use Custom Profile 1 as the name of the custom profile.

# Configuring 100G Licenses for Supervisor 250G

The Cisco cBR Smart Account supports both 100G WAN licenses and 10G WAN licenses.

You need to configure the Cisco cBR to consume 100G WAN licenses for Supervisor 250G. This would accommodate existing 10G WAN licenses for 100G port, in addition to the 100G WAN license.

Starting from Cisco cBR release IOS-XE 16.8.1, there will be two types of WAN licenses in the Smart Account for WAN ports on the Cisco cBR Supervisor 250G module:

- 100G WAN license: By default, the Smart Account will consume the 100G WAN license for 100G WAN port.
- 10G WAN license: Can be applied to 10G and 100G WAN ports.

## Overview of 100G License for Supervisor 250G

With the 100G WAN licenses, you can facilitate the ordering and management of WAN license for Supervisor 250G. This would help avoid the overhead of maintaining multiple 10G WAN licenses, and you can manage a single 100G WAN license for one 100G port of Supervisor 250G, instead of ten individual 10G WAN licenses.

However, there is no auto-conversion between 10G WAN licenses and 100G WAN licenses. They must be ordered and managed separately. If you are an existing customer using 10G WAN license for Supervisor 250G and have not purchased any 100G WAN licenses, the Cisco Smart Licensing will report out of compliance when attempting to upgrade to Cisco cBR release IOS-XE 16.8.1.

For information on configuring the Cisco cBR to consume 10G WAN licenses on 100G port for Supervisor 250G, see [Applying 10G WAN License to the 100G WAN Ports, on page 56](#).



---

**Note**

- In Supervisor 160, there is no 100G WAN interface and WAN 100G License. The display is same as the previous release.
  - The 100G license feature does not support an ISSU downgrade. This might cause a standby SUP crash.
- 

## Applying 10G WAN License to the 100G WAN Ports

Ensure that you go through [Overview of 100G License for Supervisor 250G, on page 56](#) for an understanding of the feature and the restrictions.

The Smart Account will consume the 100G WAN license for 100G WAN port by default. To apply the 10G WAN licenses for the 100G WAN port, complete the following step.

### SUMMARY STEPS

1. You can apply the 10G WAN license to the 100G WAN ports using the following command:

## DETAILED STEPS

	Command or Action	Purpose
Step 1	<p>You can apply the 10G WAN license to the 100G WAN ports using the following command:</p> <p><b>Example:</b></p> <pre>Router(config)# cable license 100G-conversion</pre> <p>To disable the 10G WAN license for 100G WAN ports, run the command with the <i>no</i> option. This would enable the 100G WAN ports to consume 100G WAN license.</p> <pre>Router(config)# no cable license 100G-conversion</pre>	

## Displaying the License Information

You can use the following command options to display the license information, based on whether the license has been configured or not:

## SUMMARY STEPS

1. Run either of the following command options to display license information.

- By default, or with the *no* option, the ports will consume a 100G WAN license for a 100G WAN port.

For example if the **no cable license 100G-conversion** command has been issued, the responses to the **show cable license wan** and **show license summary** commands would be in the following format:

```
Router(config)# show cable license wan
-----
Entitlement:  WAN License
Consumed count: 0
Consumed count reported to SmartAgent: 0
Enforced state: No Enforcement

-----

Entitlement:  WAN 100G License
Consumed count: 2
Consumed count reported to SmartAgent: 2
Enforced state: No Enforcement

Router(config)# show license summary
Smart Licensing is ENABLED

Registration:
  Status: REGISTERED
  Smart Account: CBR8_DEV_1
  Virtual Account: cbr8-dev-test
  Export-Controlled Functionality: Allowed
  Last Renewal Attempt: None
  Next Renewal Attempt: Jun 13 00:47:13 2018 CST

License Authorization:
  Status: AUTHORIZED
```

```

Last Communication Attempt: SUCCEEDED
Next Communication Attempt: Jan 14 11:34:13 2018 CST

License Usage:
License                               Entitlement tag                Count Status
-----
regid.2017-09.com.ci... (WAN_100G_License)          2 AUTHORIZED

```

- With the **cable license 100G-conversion** command, it will consume 10G WAN license for 100G WAN port.

For example if the **cable license 100G-conversion** command has been issued, the responses to the **show cable license wan** and **show license summary** commands would be in the following format:

```

Router(config)# show cable licenses wan
-----
Entitlement:  WAN License
Consumed count: 20
Consumed count reported to SmartAgent: 20
Enforced state: No Enforcement

-----

Entitlement:  WAN 100G License
Consumed count: 0
Consumed count reported to SmartAgent: 0
Enforced state: No Enforcement

Router(config)# show license summary
Smart Licensing is ENABLED

Registration:
Status: REGISTERED
Smart Account: CBR8_DEV_1
Virtual Account: cbr8-dev-test
Export-Controlled Functionality: Allowed
Last Renewal Attempt: None
Next Renewal Attempt: Jun 13 00:47:13 2018 CST

License Authorization:
Status: AUTHORIZED
Last Communication Attempt: SUCCEEDED
Next Communication Attempt: Jan 14 11:25:01 2018 CST

License Usage:
License                               Entitlement tag                Count Status
-----
regid.2014-11.com.ci... (WAN_License)                20 AUTHORIZED

```

## DETAILED STEPS

	Command or Action	Purpose
Step 1	<p>Run either of the following command options to display license information.</p> <ul style="list-style-type: none"> <li>• By default, or with the <i>no</i> option, the ports will consume a 100G WAN license for a 100G WAN port.</li> </ul>	

	Command or Action	Purpose
	<p>For example if the <b>no cable license 100G-conversion</b> command has been issued, the responses to the <b>show cable license wan</b> and <b>show license summary</b> commands would be in the following format:</p> <pre>Router(config)# show cable license wan ----- Entitlement: WAN License Consumed count: 0 Consumed count reported to SmartAgent: 0 Enforced state: No Enforcement  ----- Entitlement: WAN 100G License Consumed count: 2 Consumed count reported to SmartAgent: 2 Enforced state: No Enforcement  Router(config)# show license summary  Smart Licensing is ENABLED  Registration:   Status: REGISTERED   Smart Account: CBR8_DEV_1   Virtual Account: cbr8-dev-test   Export-Controlled Functionality: Allowed   Last Renewal Attempt: None   Next Renewal Attempt: Jun 13 00:47:13 2018 CST  License Authorization:   Status: AUTHORIZED   Last Communication Attempt: SUCCEEDED   Next Communication Attempt: Jan 14 11:34:13 2018 CST  License Usage:   License                               Entitlement tag       Count Status  -----   regid.2017-09.com.ci... (WAN_100G_License)       2 AUTHORIZED</pre> <ul style="list-style-type: none"> <li>• With the <b>cable license 100G-conversion</b> command, it will consume 10G WAN license for 100G WAN port.</li> </ul> <p>For example if the <b>cable license 100G-conversion</b> command has been issued, the responses to the <b>show cable license wan</b> and <b>show license summary</b> commands would be in the following format:</p> <pre>Router(config)# show cable licenses wan ----- Entitlement: WAN License</pre>	

	Command or Action	Purpose
	<pre> Consumed count: 20 Consumed count reported to SmartAgent: 20 Enforced state: No Enforcement  ----- Entitlement: WAN 100G License Consumed count: 0 Consumed count reported to SmartAgent: 0 Enforced state: No Enforcement  Router(config)# show license summary Smart Licensing is ENABLED  Registration: Status: REGISTERED Smart Account: CBR8_DEV_1 Virtual Account: cbr8-dev-test Export-Controlled Functionality: Allowed Last Renewal Attempt: None Next Renewal Attempt: Jun 13 00:47:13 2018 CST  License Authorization: Status: AUTHORIZED Last Communication Attempt: SUCCEEDED Next Communication Attempt: Jan 14 11:25:01 2018 CST  License Usage: License                Entitlement tag           Count Status  ----- regid.2014-11.com.ci... (WAN_License)           20 AUTHORIZED </pre>	

## Feature Information for 100G License for Supervisor 250G

Use Cisco Feature Navigator to find information about the platform support and software image support. Cisco Feature Navigator enables you to determine which software images support a specific software release, feature set, or platform. To access Cisco Feature Navigator, go to the <https://cfnng.cisco.com/> link. An account on the Cisco.com page is not required.



**Note** The following table lists the software release in which a given feature is introduced. Unless noted otherwise, subsequent releases of that software release train also support that feature.



Table 5: Feature Information for 100G License for Supervisor 250G

Feature Name	Releases	Feature Information
100G License for Supervisor 250G	Cisco IOS-XE Release 16.8.1	This feature was integrated into Cisco IOS-XE Release 16.8.1 on the Cisco cBR Series Converged Broadband Routers.

## Verifying Cisco Smart Licensing Configuration

Use the following commands to verify the Cisco Smart Licensing Configuration on the Cisco cBR router:

- **show license all**—Displays all the license information.

The following is a sample output of this command:

```
Router# show license all

Smart Licensing Status
=====

Smart Licensing is ENABLED

Registration:
  Status: REGISTERED
  Virtual Account: auto-test-1
  Initial Registration: SUCCEEDED on Mar  5 02:01:03 2015 UTC
  Last Renewal Attempt: None
  Next Renewal Attempt: Sep  1 02:03:51 2015 UTC
  Registration Expires: Never

License Authorization:
  Status: OUT OF COMPLIANCE on Mar  5 03:34:54 2015 UTC
  Last Communication Attempt: SUCCEEDED on Mar  5 03:35:57 2015 UTC
  Next Communication Attempt: Mar  5 15:35:57 2015 UTC
  Communication Deadline: Jun  3 03:32:51 2015 UTC

License Usage
=====

(US_License):
  Description:
  Count: 64
  Version: 1.0
  Status: AUTHORIZED

(DS_License):
  Description:
  Count: 768
  Version: 1.0
  Status: AUTHORIZED

(WAN_License):
  Description:
  Count: 8
  Version: 1.0
  Status: OUT OF COMPLIANCE

Product Information
=====
```

```

UDI: PID:CBR-8-CCAP-CHASS,SN:FXS1739Q0NT

HA UDI List:
  Active:PID:CBR-8-CCAP-CHASS,SN:FXS1739Q0NT
  Standby:PID:CBR-8-CCAP-CHASS,SN:FXS1739Q0NT

Agent Version
=====
Smart Agent for Licensing: 1.2.1_throttle/5
Component Versions: SA:(1_2_1_throttle)1.1.0, SI:(rel20)1.0.1, CH:(rel4)1.0.15,
PK:(rel16)1.0.7

```

- **show license status**—Displays the license status information.

The following is a sample output of this command:

```

Router# show license status

Smart Licensing is ENABLED

Registration:
  Status: REGISTERED
  Virtual Account: auto-test-1
  Initial Registration: SUCCEEDED on Mar  5 02:01:03 2015 UTC
  Last Renewal Attempt: None
  Next Renewal Attempt: Sep  1 02:03:51 2015 UTC
  Registration Expires: Never

License Authorization:
  Status: OUT OF COMPLIANCE on Mar  5 03:34:54 2015 UTC
  Last Communication Attempt: SUCCEEDED on Mar  5 03:35:57 2015 UTC
  Next Communication Attempt: Mar  5 15:35:56 2015 UTC
  Communication Deadline: Jun  3 03:32:50 2015 UTC

```

- **show license summary**—Displays the license summary information.

The following is a sample output of this command:

```

Router# show license summary

Smart Licensing is ENABLED

Registration:
  Status: REGISTERED
  Virtual Account: auto-test-1
  Last Renewal Attempt: None
  Next Renewal Attempt: Sep  1 02:03:51 2015 UTC

License Authorization:
  Status: OUT OF COMPLIANCE
  Last Communication Attempt: SUCCEEDED
  Next Communication Attempt: Mar  5 15:35:56 2015 UTC

License Usage:

```

License	Entitlement tag	Count	Status
	(US_License)	64	AUTHORIZED
	(DS_License)	768	AUTHORIZED
	(WAN_License)	8	OUT OF COMPLIANCE

- **show license tech support**—Displays the license technical support information.

The following is a sample output of this command:

```
Router# show license tech support

Smart Licensing Tech Support info

Smart Licensing Status
=====

Smart Licensing is ENABLED

Registration:
  Status: REGISTERED
  Virtual Account: auto-test-1
  Initial Registration: SUCCEEDED on Mar  5 02:01:03 2015 UTC
  Last Renewal Attempt: None
  Next Renewal Attempt: Sep  1 02:03:51 2015 UTC
  Registration Expires: Never

License Authorization:
  Status: OUT OF COMPLIANCE on Mar  5 03:34:54 2015 UTC
  Last Communication Attempt: SUCCEEDED on Mar  5 03:35:57 2015 UTC
  Next Communication Attempt: Mar  5 15:35:57 2015 UTC
  Communication Deadline: Jun  3 03:32:51 2015 UTC

Evaluation Period:
  Evaluation Mode: Not In Use
  Evaluation Period Remaining: 89 days, 23 hours, 25 minutes, 40 seconds

License Usage
=====
Handle: 1
  License: 'nullPtr'
  Entitlement Tag:
  regid.2014-11.com.cisco.US_License,1.0_a3f32909-2c71-426c-b3e0-eeefc946f9b3
  Description: <empty>
  Count: 64
  Version: 1.0
  Status: AUTHORIZED(3)
  Status time: Mar  5 03:34:54 2015 UTC
  Request Time: Mar  5 03:34:17 2015 UTC

Handle: 2
  License: 'nullPtr'
  Entitlement Tag:
  regid.2014-11.com.cisco.DS_License,1.0_71ad0ae1-5e5e-4f02-b380-d2e1b8dcfa03
  Description: <empty>
  Count: 768
  Version: 1.0
  Status: AUTHORIZED(3)
  Status time: Mar  5 03:34:54 2015 UTC
  Request Time: Mar  5 03:34:17 2015 UTC

Handle: 3
  License: 'nullPtr'
  Entitlement Tag:
  regid.2014-11.com.cisco.WAN_License,1.0_3d8bb7ba-1a92-4f01-a4aa-a4479f1d7612
  Description: <empty>
  Count: 8
  Version: 1.0
  Status: OUT OF COMPLIANCE(4)
  Status time: Mar  5 03:34:54 2015 UTC
  Request Time: Mar  5 03:34:17 2015 UTC
```

```

Product Information
=====
UDI: PID:CBR-8-CCAP-CHASS,SN:FXS1739Q0NT

HA UDI List:
  Active:PID:CBR-8-CCAP-CHASS,SN:FXS1739Q0NT
  Standby:PID:CBR-8-CCAP-CHASS,SN:FXS1739Q0NT

Agent Version
=====
Smart Agent for Licensing: 1.2.1_throttle/5
Component Versions: SA:(1_2_1_throttle)1.1.0, SI:(rel20)1.0.1, CH:(rel4)1.0.15,
PK:(rel16)1.0.7

Upcoming Scheduled Jobs
=====
Current time: Mar  5 03:37:46 2015 UTC
IdCert Expiration Warning: Jan  4 02:00:41 2016 UTC (304 days, 22 hours, 22 minutes,
55 seconds remaining)
Daily: Mar  6 03:21:11 2015 UTC (23 hours, 43 minutes, 25 seconds remaining)
Certificate Renewal: Sep  1 02:03:51 2015 UTC (179 days, 22 hours, 26 minutes, 5 seconds
remaining)
Certificate Expiration Check: Mar  4 02:00:41 2016 UTC (364 days, 22 hours, 22 minutes,
55 seconds remaining)
Authorization Renewal: Mar  5 15:35:57 2015 UTC (11 hours, 58 minutes, 11 seconds
remaining)
Authorization Expiration Check: Jun  3 03:32:51 2015 UTC (89 days, 23 hours, 55 minutes,
5 seconds remaining)
Init Flag Check: Not Available

License Certificates
=====
Production Cert: True
PIID: 36bf91ae-0577-4213-9e62-1b6ee0add02f
Licensing Certificated:
  Id certificate Info:
    Start Date: Mar  5 01:57:54 2015 UTC
    Expiry Date: Mar  4 01:57:54 2016 UTC
    Version Number: 3
    Serial Number: 134418
    Common Name: 05FB26B1A58A106DEA6878C346432186D08BC1C5::1,2

  Signing certificate Info:
    Start Date: Jun 14 20:18:52 2013 UTC
    Expiry Date: Apr 24 21:55:42 2033 UTC
    Version Number: 3
    Serial Number: 3
    Common Name: MMI Signer

  Sub CA Info:
    Start Date: Apr 24 22:19:15 2013 UTC
    Expiry Date: Apr 24 21:55:42 2033 UTC
    Version Number: 3
    Serial Number: 2
    Common Name: Smart Licensing CA - DEV

HA Info
=====
RP Role: Active
Chassis Role: Active
Behavior Role: Active
RMF: True
CF: True

```

```

CF State: Stateless

Other Info
=====
Software ID: regid.2014-12.com.cisco.CBR8V1,1.0_95948658-0b8b-4e8f-838d-b17020364ca9
Agent State: OOC
TS enable: True
Transport: Callhome
Locale: en_US.UTF-8
Debug flags: 0x7
Privacy Send Hostname: True
Privacy Send IP: True
Build type:: Production
sizeof(char)  : 1
sizeof(int)   : 4
sizeof(long)  : 4
sizeof(char *) : 8
sizeof(time_t) : 4
sizeof(size_t) : 8
Endian: Big
enableOnInit: True
routingReadyByEvent: True
systemInitByEvent: True
WaitForHaRole: False
standbyIsHot: True
chkPtType: 2
delayCommInit: False
roleByEvent: True
maxTraceLength: 150
traceAlwaysOn: False
debugFlags: 7

```

- **show license udi**—Displays the license Unique Device Identifier (UDI) information.

The following is a sample output of this command:

```

Router# show license udi

UDI: PID:CBR-8-CCAP-CHASS,SN:FXS1739Q0NT

HA UDI List:
  Active:PID:CBR-8-CCAP-CHASS,SN:FXS1739Q0NT
  Standby:PID:CBR-8-CCAP-CHASS,SN:FXS1739Q0NT

```

- **show license usage**—Displays the license usage information.

The following is a sample output of this command:

```

Router# show license usage

License Authorization:
  Status: OUT OF COMPLIANCE on Mar  5 03:34:54 2015 UTC

(US_License):
  Description:
  Count: 64
  Version: 1.0
  Status: AUTHORIZED

(DS_License):
  Description:
  Count: 768
  Version: 1.0
  Status: AUTHORIZED

```

```
(WAN_License):
  Description:
  Count: 8
  Version: 1.0
  Status: OUT OF COMPLIANCE
```

- **show call-home profile all**—Displays the call home profile information for all configured profiles.

The following is a sample output of this command:

```
Router# show call-home profile all

Profile Name: CiscoTAC-1
  Profile status: ACTIVE
  Profile mode: Full Reporting
  Reporting Data: Smart Call Home, Smart Licensing
  Preferred Message Format: xml
  Message Size Limit: 3145728 Bytes
  Transport Method: http
  Email address(es): callhome@cisco.com
  HTTP address(es): https://tools.cisco.com/its/service/oddce/services/DDCEService

Periodic configuration info message is scheduled every 25 day of the month at 10:03

Periodic inventory info message is scheduled every 25 day of the month at 09:48

Alert-group          Severity
-----
crash                debug
diagnostic           minor
environment          minor
inventory            normal

Syslog-Pattern      Severity
-----
.*                  major
```

- **show call-home smart-licensing statistics**—Displays the call home smart licensing statistics information.

The following is a sample output of this command:

```
Router# show call-home smart-licensing statistics

Success: Successfully sent and response received.
Failed : Failed to send or response indicated error occurred.
Inqueue: In queue waiting to be sent.
Dropped: Dropped due to incorrect call-home configuration.

Msg Subtype      Success Failed  Inqueue Dropped Last-sent (GMT-06:00)
-----
REGISTRATION     1       0       0       0       2015-03-13 13:12:13
ACKNOWLEDGEMENT 1       0       0       0       2015-03-13 13:12:20
ENTITLEMENT      5       0       0       0       2015-03-13 13:22:18
```

Use the following commands to verify the DOCSIS 3.1 Downstream License on the Cisco cBR router:

- **show cable license all | begin D3.1**—Displays all the DOCSIS 3.1 downstream license information.

The following is a sample output of this command:

```

Router# show cable license all | begin D3.1

Load for five secs: 21%/1%; one minute: 52%; five minutes: 52%
Time source is NTP, 10:41:11.175 PST Mon May 9 2016
-----
Entitlement:  DOCSIS 3.1 Downstream Channel License
Consumed count: 31
Consumed count reported to SmartAgent: 0
Enforced state: No Enforcement

```

Use the following commands to verify the DOCSIS 3.1 Upstream Exclusive License on the Cisco cBR router:

- **show cable licenses us\_d31\_exclusive**—Displays the DOCSIS 3.1 upstream exclusive license information.

The following is a sample output of this command:

```

Router# show cable licenses us_d31_exclusive
Load for five secs: 99%/2%; one minute: 21%; five minutes: 6%
Time source is NTP, *10:14:30.935 CST Tue Jun 6 2017
-----
Entitlement:  DOCSIS 3.1 Upstream Channel Exclusive License
Total Licensed Spectrum: 1880000000Hz
Consumed count: 188
Consumed count reported to SmartAgent: 188
Enforced state: No Enforcement

```

## Troubleshooting Cisco Smart Licensing

Before taking the steps below to troubleshoot the Cisco Smart Licensing, the customers should first make sure the configuration is correct and see if they are able to ping the HTTP address they have configured for the smart license. The output of the **show call-home smart-licensing statistics** command should have REGISTERED and ACKNOWLEDGE information. And check the output of **show logging | include SMART | CALL**.

## Manually Renewing the Smart License Registration

The license agent automatically renews the registration information with Cisco every 30 days. You may need to manually renew the registration if the license is out of compliance and it needs to be registered immediately.

### Procedure

	Command or Action	Purpose
Step 1	<b>enable</b> <b>Example:</b> Router> <b>enable</b>	Enables privileged EXEC mode. <ul style="list-style-type: none"> <li>• Enter your password if prompted.</li> </ul>
Step 2	<b>license smart renew</b> <b>Example:</b> Router# <b>license smart renew</b>	Manually renews the license registration of the device instance with Cisco.

## Unregistering the Router from Cisco Smart Licensing

You can unregister the router from Cisco Smart Licensing. You may need to unregister the router for the Return Material Authorization (RMA) of the router.

### Procedure

	Command or Action	Purpose
<b>Step 1</b>	<b>enable</b> <b>Example:</b> Router> <code>enable</code>	Enables privileged EXEC mode. <ul style="list-style-type: none"> <li>• Enter your password if prompted.</li> </ul>
<b>Step 2</b>	<b>license smart deregister</b> <b>Example:</b> Router# <code>license smart deregister</code>	Removes the Cisco Smart Licensing registration for the device instance. All Cisco Smart Licensing certificates and entitlements are removed.

## Flexible Consumption Model (FCM) Licenses

Smart Licensing supports the Flexible Consumption (FCM) licensing model. This model of licensing is available at low initial investment, provides easy scalability, and allows you to increase consumption of licenses as they expand. Flexible Consumption model licenses are checked for usage on a monthly basis. The monthly license usage is reported to the Smart Licensing Manager at Cisco.com.

In order to provide the simplification and flexibility to purchase software capacity as needed, FCM is metering the number of Subscribers(Modems) it has for each tier (Essential, Advantage, or Premier) which is based on the number of channels that are configured per Service Group:

- Essential (ES) tier is for 0–48 channels per Service Group.
- Advantage(AD) tier is for 49–80 channels per Service Group.
- Premier(PR) tier is for 81 and above channels per Service Group.

### Benefits of FCM

- *Pay-as-you-grow*: Enables you to lower initial costs and add more capacity over time using Software Innovation Access (SIA)
- *Great Value*: Select the right tier, based on your needs (Essential, Advantage, Premier).
- *Simple*: Few pricing and service options.
- *Consistency*: Right-to-Use (RTU) model based on per subscriber (end user) basis aligned with other Cisco Service Provider products.

Pricing for Cisco cBR-8 routers consists of a perpetual license, **software innovation access (SIA) subscription, and Cisco Solution Support Services.**

- Perpetual licenses are charged as a one-time payment per end customer who is serviced by the platform and entitle permanent right-to-use of the cBR8 software.



- SIA is charged as a three, four, or five year subscription per end customer who is serviced by the platform, and entitles major software version upgrades during the subscription period. At the end of the initial subscription, you can renew the SIA subscriptions on an annual basis.
- Support Services (either SWSS-Basic or Solution Support) is required on the perpetual licenses for access to Technical Support and SW maintenance releases. Term of Support Services must align to the duration of the SIA subscription (i.e. three, four, or five years).

The following table shows the FCM PID list:

**Table 6: Flexible Consumption Model License PID List**

PID	Option Class	Sub-Option Class	Maximum Supported Channels Per Service Group	Rules
CBR8SW	Nested Model			
	CBR-8 Essential RTU SW License			CBR-8 Per subscriber perpetual SW license applications
		CBR8-ES-RTU	48 channels	Per subscriber perpetual SW license applications.
		CBR8-ES-SIA-3		Annual subscription 3-year SIA stand
		CBR8-ES-SIA-5		Annual subscription 5-year SIA stand
		CBR8-ES-SIA-7		Annual subscription 7-year SIA stand
		CBR8-ES-SIA-ST		Renewal PID for Transactional Esser
	CBR-8 Advantage RTU SW License			CBR-8 Per subscriber perpetual SW license applications.
		CBR8-AD-RTU	80 Channels	Per subscriber perpetual SW license applications
		CBR8-AD-SIA-3		Annual subscription 3 year SIA stand
		CBR8-AD-SIA-5		Annual subscription 5 year SIA stand
		CBR8-AD-SIA-7		Annual subscription 7 year SIA stand
		CBR8-AD-SIA-ST		Renewal PID for Transactional Adva
	CBR-8 Premier RTU SW License			CBR-8 Premier Tier per subscriber P
		CBR8-PR-RTU	Unlimited Channels	Per subscriber perpetual SW license applications
		CBR8-PR-SIA-3		Annual subscription 3-year SIA stand
		CBR8-PR-SIA-5		Annual subscription 5-year SIA stand
		CBR8-PR-SIA-7		Annual subscription 7-year SIA stand

PID	Option Class	Sub-Option Class	Maximum Supported Channels Per Service Group	Rules
		CBR8-PR-SIA-ST		Renewal PID for Transactional Premier S

Cisco cBR-8 routers either supports Traditional Mode License or FCM License, it does not allow combining FCM and Traditional Mode License. The Traditional Mode License is enabled by default. Use the `cable license enable-FCM` command to enable FCM. Use `no cable license enable-FCM` to disable FCM.

**Table 7: Differences Between Traditional Smart License**

Traditional Smart License	FCM
Bandwidth based model	Subscriber based model
Enabled by default	Use the <code>cable license enable-FCM</code> command to enable FCM. Use <code>no cable license enable-FCM</code> to disable FCM.
Enforced license types: <ul style="list-style-type: none"> <li>• LCHA_License</li> <li>• DS_License</li> <li>• US_License</li> <li>• DS_D31_License</li> <li>• US_D31_License</li> <li>• WAN_License</li> <li>• NC_License</li> <li>• RPHY_BC_Video</li> </ul>	Enforced license types: <ul style="list-style-type: none"> <li>• LCHA_License</li> <li>• CBR8_ESS_RTU/ CR8_ADV_RTU/ CBR8_PRE_RTU</li> <li>• CBR8_ESS_SIA/ CR8_ADV_SIA/ CBR8_PRE_SIA</li> </ul>
All Cisco IOS XE releases are supported.	Supported on Cisco IOS XE Cupertino 17.9.1w releases or later.

The following example shows the Traditional Mode License Summary:

### Traditional Mode License Summary

```
router#show license summary
Load for five secs: 71%/4%; one minute: 62%; five minutes: 59%
Time source is NTP, 00:05:01.752 CST Mon Oct 17 2022
```

```
Smart Licensing is ENABLED
```

```
Registration:
Status: REGISTERED
Smart Account: BU Production Test 1
```

```

Virtual Account: CBR8-STG2
Export-Controlled Functionality: ALLOWED
Last Renewal Attempt: None
Next Renewal Attempt: Apr 14 22:51:18 2023 CST

```

```

License Authorization:
  Status: AUTHORIZED
  Last Communication Attempt: PENDNG
  Next Communication Attempt: Oct 17 23:07:06 2022 CST

```

```
License Usage:
```

License	Entitlement Tag	Count	Status
CBR8 DOCSIS 3.0 Upst...	(US_License)	1279	AUTHORIZED
CBR8 VOD/SDV Downstr...	(NC_License)	744	AUTHORIZED
CBR8 DOWNSTREAM RPHY...	(RPHY_BC_Video)	5	AUTHORIZED
CBR8 Supervisor 10G ...	(WAN_License)	12	AUTHORIZED
CBR8 DOCSIS 3.0 Down...	(DS_License)	3005	AUTHORIZED
CBR8 D3.1 Downstream...	(DS_D31_License)	1324	AUTHORIZED
cBR8 DOCSIS 3.0 Line-...	(DLCHA_License)	1	AUTHORIZED

### Determining Service Group(SG) Size

Service Group size only considers DOCSIS channels. Service Group only considers DS channel and does not consider US channel.

- For I-CMTS, one SG is a DS port. The DS port is DS controller port from CMTS.
- For RPHY, one SG is an RPD DS port.

Service Group considers max channels that are configured in the group, regardless if channel is up or down. The OFDM channels are calculated as the sums total of all licensed spectrum, which is divided by 6, and then rounded up. For example:

- In a Service Group –24 SC QAMs for DOCSIS 3.0 + 96 MHz (equivalent to 16- 6-Mhz channels) of OFDM for D3.1 = 40 total channels (24 + 16). This is an Essential Tier.
- In a Service Group –32 SC QAMs for DOCSIS 3.0 + 192 MHz (equivalent to 32- 6-Mhz channels) of OFDM for D3.1 = 64 total channels (32 + 32). This is an Advantage Tier.

### Determining Service Tier

A Cisco cBR-8 router can only have one service tier i.e Essential, Advantage, or Premier, but can't have a mixture of them. Here is the chassis level service tier Algorithm with 5% Allowance:

- Essential SG count  $\geq$  total SG count \* (1–5%), Cisco cBR-8 router service tier is **Essential**.
- Premier SG count  $>$  total SG count \* 5%, Cisco cBR-8 router service tier is **Premier**.
- If the previous two conditions are not met, then Cisco cBR-8 router service tier is **Advantage**.

For example, on a Cisco cBR-8 router, there are 19 Essential SGs (48 DS channels) and 1 Advantage SG (64 DS channels), then this chassis level service tier is **Essential** Tier ( $19/(19+1) = 95\%$ ).

### Cisco cBR-8 Router Reporting to CSSM

Cisco cBR-8 routers report the number of subscribers that it has for each tier (Essential, Advantage, or Premier). Every license has two entitlements. The entitlement types are the right-to-use (RTU) and Software Innovation Access (SIA). Cisco cBR-8 routers report same number of licenses in both RTU and SIA to server. Cisco

cBR-8 routers report subscribers to Cisco Smart Software Manager (CSSM) in one hour after bootup or SUP switchover, post that it reports Monthly. Cisco cBR-8 routers keeps track of the number of channels per SG and total modems count over the whole month. For example, if Cisco cBR-8 routers did 30 samples in one month, and the highest modems count and tier of the 30 samples are used for reporting. Cisco cBR-8 routers store the highest subscriber(modem) count during the reporting period, regardless if the modem is online or offline. DSG STB devices are excluded from subscriber statistics.(Use the `show cable modem docsis device-class` command.). Traditional licenses types are not reported in FCM model except LCHA license.

### CSSM Response to Cisco cBR-8 Router

The Hierarchy license structure is as follows: Premier>Advanced>Essential. If there are sufficient RTU/SIA licenses in reported tier, then server response is **Compliance**. If the server does not have insufficient RTU/SIA licenses in the reported or higher tier, then server response is **Out of Compliance (OOC)**. If there are insufficient RTU/SIA licenses in reported tier, then the server automatically tries to use licenses of a higher level than what is reported.

The following is an example where the server response is **Compliance**:

CSSM has licenses: 1000 Essential-RTU License, 100 Advantage-RTU, 10 Premier-RTU. cBR-8 reports 1050 Essential-RTU to CSSM, CSSM uses 1000 Essential-RTU License + 50 Advantage-RTU.  $1000 + 100 > 1050$ .

The following is an example where the server response is **Out of Compliance (OOC)**:

CSSM has licenses: 100 Essential -RTU License, 1000 Advantage-RTU, 10 Premier-RTU. cBR-8 reports 1050 Advantage-RTU to CSSM, CSSM uses 1000 Advantage -RTU License + 10 Premier-RTU,  $1000 + 10 < 1050$ .

Order the required amount of RTU & SIA subscriptions licenses, based on the service tier and number of subscribers that you plan to deploy.

### FCM License Summary

The following example shows how to deploy an FCS License.

```
router(config)#cable license enable-FCM

router#show license summary
Load for five secs: 26%/2%; one minute: 31%; five minutes: 31%
Time source is NTP, 00:07:14.392 CST Mon Oct 17 2022

Smart Licensing is ENABLED
Registration:
  Status: REGISTERED
  Smart Account: BU Production Test 1
  Virtual Account: CBR8-STG2
  Export-Controlled Functionality: ALLOWED
  Last Renewal Attempt: None
  Next Renewal Attempt: Apr 12 10:32:34 2023 CST

License Authorization:
  Status: AUTHORIZED
  Last Communication Attempt: SUCCEEDED
  Next Communication Attempt: Nov 16 00:07:12 2022 CST

License Usage:
  License                               Entitlement Tag                Count Status
  -----
  CBR DOCSIS 3.0 Line-... (LCHA_License) 5 AUTHORIZED
```

CBR8 - Advantage - RTU (CBR8\_ADV\_RTU)  
 CBR8 - Advantage Sub... (CBR8\_ADV\_SIA)

264 AUTHORIZED  
 164 AUTHORIZED

## Additional References

### Related Documents

Related Topic	Document Title
Cisco Smart Licensing	<a href="#">Cisco Smart Software Licensing</a>

### Technical Assistance

Description	Link
<p>The Cisco Support website provides extensive online resources, including documentation and tools for troubleshooting and resolving technical issues with Cisco products and technologies.</p> <p>To receive security and technical information about your products, you can subscribe to various services, such as the Product Alert Tool (accessed from Field Notices), the Cisco Technical Services Newsletter, and Really Simple Syndication (RSS) Feeds.</p> <p>Access to most tools on the Cisco Support website requires a Cisco.com user ID and password.</p>	<a href="http://www.cisco.com/support">http://www.cisco.com/support</a>

## Feature Information for Cisco Smart Licensing

Use Cisco Feature Navigator to find information about the platform support and software image support. Cisco Feature Navigator enables you to determine which software images support a specific software release, feature set, or platform. To access Cisco Feature Navigator, go to the <https://cfng.cisco.com/> link. An account on the Cisco.com page is not required.



**Note** The following table lists the software release in which a given feature is introduced. Unless noted otherwise, subsequent releases of that software release train also support that feature.

**Table 8: Feature Information for Cisco Smart Licensing**

Feature Name	Releases	Feature Information
Cisco Smart Licensing	Cisco IOS XE Fuji 16.7.1	This feature was integrated on the Cisco cBR Series Converged Broadband Routers.
DOCSIS 3.1 US Channel Licensing	Cisco IOS XE Fuji 16.7.1	This feature was integrated on the Cisco cBR Series Converged Broadband Routers.





## CHAPTER 3

# Core Peak Bandwidth Licensing

The Core Peak Bandwidth (CPB) license enables you to manage Cisco cBR-8 routers with one comprehensive license, unlike the multiple license types associated with the traditional licensing models. This document provides information on CPB and how to configure the license on Cisco cBR-8 routers.

- [Core Peak Bandwidth License, on page 75](#)
- [Configure CPB on Cisco cBR Routers, on page 76](#)
- [Feature Information for Core Peak Bandwidth Licensing , on page 77](#)

## Core Peak Bandwidth License

The CPB licensing plan functions on a quarterly basis. In this plan, you pay for additional Core Peak Bandwidth licenses that you require. The cost of the CPB licenses is proportional to the number of subscribers on the Cisco cBR-8 router, as the network traffic through a CCAP core is proportional to the number of subscribers on the router.

In each quarter, as the CPB grows, additional CPB licenses equal to the growth are automatically billed and added to your existing CPB license inventory.

## CPB Calculation

The total CPB is calculated by measuring the core traffic through all the CCAP cores, taking the 95th percentile of the monthly peak, and reporting the quarterly value on the first day of the next quarter to the Smart License server to automatically manage the licensing process. The Smart License server automatically invoices for additional licensing needs and then delivers the licenses when you pay.

The traffic rate is measured every 5 minutes. Cisco cBR-8 routers save this data for a minimum of three months. The monthly CPB value is calculated and the maximum monthly value is considered as the quarterly CPB.

When you enable CPB on Cisco cBR-8, the initial CPB value is measured as 1.

For measuring the CPB, 12 samples are collected in every hour, which is one sample every 5 minutes. Due to a maintenance window or a shutdown, which approximately is less than 5 hours, if samples are lost and the number of lost samples is more than 60 in a month, the cable operator is notified with an error message. If the chassis serial number does not match the local chassis serial number, these sample records are deleted when starting the router or rebooting it. The sample history is also cleared when a Supervisor card is replaced.

To calculate the monthly CPB value, the Cisco cBR router rates all samples collected in one month based on the speed. For example, if 8767 samples are collected in a month, and the 8767th sample is the fastest, then the 95th percentile is the 8329th sample rated by speed (consider the first sample as the slowest and the 8767th the fastest). Hence, the CPB value for that month is the value of the 8329th sample divided by 100 (100Mbps).

## Configure CPB on Cisco cBR Routers

### Enable CPB Licensing

To enable CPB and show only the CPB usage, use the following command. When you enable CPB, the other existing licensing features are canceled automatically.

```
cable license enable-CPB
```

Use the `no cable license enable-CPB` command to disable CPB. By default, CPB is disabled on Cisco cBR routers.

### View CPB Usage Details

To display CPB usage information, use the following command:

```
show cable licenses cpb
```

#### Example: Show CPB Usage Details

The following example shows CPB usage details:

```
show cable licenses cpb
Entitlement: CPB License
Consumed count: 987
Consumed count reported to SmartAgent: 987
Enforced state: No Enforcement
Quarterly CPB is 987 (100Mbps) in the First quarter of 2018.
First monthly CPB is: 103585495480 bps, 987 (100Mbps).
Second monthly CPB is: 103595095264 bps, 987 (100Mbps).
Third monthly CPB is: 103595124064 bps, 987 (100Mbps).
```

### View Details of All Licenses

To display the usage information of all licenses, use the following command.

If you enable CPB, this command displays only the CPB usage information. If CPB is disabled, the command displays the usage information of all existing licenses.

```
show cable licenses all
```

#### Example: View Details of All Licenses

The following example shows the usage information of all licenses, when CPB is enabled.

```
show cable licenses all
Entitlement: CPB License
Consumed count: 987
Consumed count reported to SmartAgent: 987
Enforced state: No Enforcement
```



```

Quarterly CPB is 987 (100Mbps) in the First quarter of 2018.
First monthly CPB is: 103585495480 bps, 987 (100Mbps).
Second monthly CPB is: 103595095264 bps, 987 (100Mbps).
Third monthly CPB is: 103595124064 bps, 987 (100Mbps).

```

## View CPB Sample History

To display the details of the CPB sample history, use the following command.

```
show cable licenses cpb-records year <year> month <month> day <day>
```

### Example: View CPB Sample History

The following example CPB sample history.

```

show cable licenses cpb-records year 2018 month 4 day 28
index: 34626, timestamp: 28-April-2018 05:30:02 UTC, 5min rate: 105291741536 bps, 1004
(100Mbps)
index: 34627, timestamp: 28-April-2018 05:35:02 UTC, 5min rate: 104006310312 bps, 991
(100Mbps)
index: 34628, timestamp: 28-April-2018 05:40:02 UTC, 5min rate: 104006237736 bps, 991
(100Mbps)
index: 34629, timestamp: 28-April-2018 05:45:02 UTC, 5min rate: 104006156168 bps, 991
(100Mbps)
index: 34650, timestamp: 28-April-2018 07:30:03 UTC, 5min rate: 47644177216 bps, 454
(100Mbps)
index: 34651, timestamp: 28-April-2018 07:35:03 UTC, 5min rate: 83840688424 bps, 799
(100Mbps)
-----
There are 6 cpb records in Apr 28 2018 UTC.

```

## Feature Information for Core Peak Bandwidth Licensing

Use Cisco Feature Navigator to find information about the platform support and software image support. Cisco Feature Navigator enables you to determine which software images support a specific software release, feature set, or platform. To access Cisco Feature Navigator, go to the <https://cfmng.cisco.com/> link. An account on the Cisco.com page is not required.



**Note** The following table lists the software release in which a given feature is introduced. Unless noted otherwise, subsequent releases of that software release train also support that feature.

**Table 9: Feature Information for Core Peak Bandwidth Licensing**

Feature Name	Releases	Feature Information
Core Peak Bandwidth Licensing	Cisco IOS XE Fuji 16.9.1a	This feature was introduced on Cisco cBR Series Converged Broadband Routers.





## CHAPTER 4

# Capped License Enforcement

---

This document provides information on the Capped License feature and on how to configure it on Cisco cBR Series Routers.

Your software release may not support all the features that are documented in this module. For the latest feature information and caveats, see the release notes for your platform and software release. The Feature Information Table at the end of this document provides information about the documented features and lists the releases in which each feature is supported.

Use Cisco Feature Navigator to find information about platform support and Cisco software image support. To access Cisco Feature Navigator, go to <http://tools.cisco.com/ITDIT/CFN/>. An account on <http://www.cisco.com/> is not required.

- [Hardware Compatibility Matrix for the Cisco cBR Series Routers, on page 79](#)
- [Information About Capped License Support, on page 81](#)
- [How to Configure Capped License Enforcement, on page 82](#)
- [Configuration Examples, on page 82](#)
- [Feature Information for Capped License Enforcement, on page 83](#)

## Hardware Compatibility Matrix for the Cisco cBR Series Routers



---

**Note** The hardware components that are introduced in a given Cisco IOS-XE Release are supported in all subsequent releases unless otherwise specified.

---

Table 10: Hardware Compatibility Matrix for the Cisco cBR Series Routers

Cisco CMTS Platform	Processor Engine	Interface Cards
Cisco cBR-8 Converged Broadband Router	<p><b>Cisco IOS-XE Release 16.5.1 and Later Releases</b></p> <p>Cisco cBR-8 Supervisor:</p> <ul style="list-style-type: none"> <li>• PID—CBR-SUP-250G</li> <li>• PID—CBR-CCAP-SUP-160G</li> </ul>	<p><b>Cisco IOS-XE Release 16.5.1 and Later Releases</b></p> <p>Cisco cBR-8 CCAP Line Cards:</p> <ul style="list-style-type: none"> <li>• PID—CBR-LC-8D30-16U30</li> <li>• PID—CBR-LC-8D31-16U30</li> <li>• PID—CBR-RF-PIC</li> <li>• PID—CBR-RF-PROT-PIC</li> <li>• PID—CBR-CCAP-LC-40G</li> <li>• PID—CBR-CCAP-LC-40G-R</li> <li>• PID—CBR-CCAP-LC-G2-R</li> <li>• PID—CBR-SUP-8X10G-PIC</li> <li>• PID—CBR-2X100G-PIC</li> </ul> <p>Digital PICs:</p> <ul style="list-style-type: none"> <li>• PID—CBR-DPIC-8X10G</li> <li>• PID—CBR-DPIC-2X100G</li> </ul> <p>Cisco cBR-8 Downstream PHY Module:</p> <ul style="list-style-type: none"> <li>• PID—CBR-D31-DS-MOD</li> </ul> <p>Cisco cBR-8 Upstream PHY Modules:</p> <ul style="list-style-type: none"> <li>• PID—CBR-D31-US-MOD</li> </ul>



**Note** Do not use DPICs (8X10G and 2x100G) to forward IP traffic, as it may cause buffer exhaustion, leading to line card reload.

The only allowed traffic on a DPIC interface is DEPI, UEPI, and GCP traffic from the Cisco cBR-8 router to Remote PHY devices. Other traffic such as DHCP, SSH, and UTSC should flow via another router, since DPICs cannot be used for normal routing.

## Information About Capped License Support

The capped license enforcement feature allows you to set a limit to the number of licenses for each licensed feature on Cisco cBR-8. Hence, with this feature, the uncontrolled usage of licensed features and the accidental consumption of more resources are kept under check. It also enables the users to track the usage per device and controls the usage of resources upfront.

If any of the capped enforcement limit is lower than the current usage number, you cannot apply the capped license option.

If capped enforcement is already in effect, the user cannot access more resources than the capped limit. The number of feature licenses accessed must be less than or equal to the capped count.

Smart License feature, which is a Reporting Model, discourages license enforcement. Hence, the Capped License Enforcement feature is disabled by default and is not publicized to every customer.

### SNMP-MIB-based Capped Enforcement

Set the cap for the features and enable the Capped-Enforcement feature using the SNMP set command. The SNMP set command is successful only when the cap enforcement count for all the features are greater than or equal to the current usage count. If the usage count for any feature is above the cap count, shutdown those resources and make sure that they are below or equal to the cap limit before issuing the SET command.

Platform, after synchronizing those values with the standby RP, enables the capped enforcement. So if the user tries to increase the usage beyond the CAP values, the resource are blocked and warning messages appear.

During the Return Material Authorization (RMA) of the SUP and when the SUP is moved across chassis, the stored cap numbers and the values configured while enabling cap enforcement are cleared. However, in a system with standby RP, if the standby RP has taken over, when the new RP is plugged in during RMA, the values are synced. In a non-redundant system, reissue the SNMP SET command after an RMA or when an SUP is moved across the chassis.

You cannot enable capped enforcement on Cisco cBR-8, which is already in a configuration lock state. However, a Cisco cBR8 that is cap enabled or not when fails to communicate with the license server for more than 90 days, moves to configuration lock state.

If you do not set the CAP count for a feature, the value is set to the default 0xffff\_ffff (268435455).

### Use Case Scenarios

The following table shows the use cases for SNMP-MIB-based capped enforcement.

If the entitlement usage is less than or equal to the CAP count	You can configure the limit and turn on additional resources. When the feature usage reaches the CAP count, the platform prevents the additional usage.
If the entitlement usage is greater than the CAP count	Stops the SNMP command from running. A message appears to inform you about this scenario and the difference in the count.

The following table shows the conditions under which you must set the CAP enable and the CAP count options.

Scenario	Non Redundant Cisco cBR	Redundant Cisco cBR
First-time boot	Yes	Yes
System reload	No	No
SSO	N/A	No
SUP RMA	Yes	No
Moving SUP across chassis	Yes	No

## How to Configure Capped License Enforcement

This section contains the following:

### Configuring Capped License Enforcement

To configure the Capped License Enforcement, use the SNMP command as given in the following example. Change the MIB value by running the following command from a Linux server:

```
snmpget -v <snmp_version_information> -c <snmp_readonly_community>
  <cBR8_Server_IP> <MIB_OID>
snmpset -v <snmp_version_information> -c <snmp_read_write_community>
  <cBR8_Server_IP> <MIB_OID> <object_type> <value>
```

### Viewing the License Usage Count

To view the license usage count of the current configuration, use the show cable license all command as given in the following example.

```
Router-config# show cable license all
```

## Configuration Examples

The following example shows how to get the **EnforcementEnabled** Global value using the community private on the server 172.25.15.210 using SNMP version 2c:

```
$ snmpget -v 2c -c public 172.25.15.210 1.3.6.1.4.1.9.9.839.1.1.3.0
```

The following example shows how to set the **EnforcementEnabled** Global value using the community private on the server 172.25.15.210 using SNMP version 2c.

```
$ snmpset -v 2c -c private 172.25.15.210 1.3.6.1.4.1.9.9.839.1.1.3.0 i 1
```

The following example shows how to set the DS license cap limit to 999999.

```
$ snmpset -v 2c -u private 123 172.25.15.210 1.3.6.1.4.1.9.9.839.1.1.4.1 u 999999
```

## Feature Information for Capped License Enforcement

Use Cisco Feature Navigator to find information about the platform support and software image support. Cisco Feature Navigator enables you to determine which software images support a specific software release, feature set, or platform. To access Cisco Feature Navigator, go to the <https://cfng.cisco.com/> link. An account on the Cisco.com page is not required.



**Note** The following table lists the software release in which a given feature is introduced. Unless noted otherwise, subsequent releases of that software release train also support that feature.

*Table 11: Feature Information for Capped License Enforcement*

Feature Name	Releases	Feature Information
Capped License Enforcement	Cisco IOS XE Everest 16.6.1	This feature was introduced in Cisco IOS XE Everest 16.6.1 on Cisco cBR Series Converged Broadband Router.







## CHAPTER 5

# Consolidated Packages and SubPackages Management

---

This document discusses how consolidated packages and software subpackages (individual and optional) are run and managed on the Cisco cBR Series Converged Broadband Router. It contains the following sections:

- [Finding Feature Information, on page 85](#)
- [Running the Cisco cBR Series Routers Using Individual and Optional SubPackages: An Overview , on page 85](#)
- [Running the Cisco cBR Series Routers Using a Consolidated Package: An Overview , on page 86](#)
- [Running the Cisco cBR Series Routers: A Summary , on page 86](#)
- [Software File Management Using Command Sets , on page 87](#)
- [Managing and Configuring the Router to Run Using Consolidated Packages and Individual SubPackages, on page 88](#)
- [Upgrading Individual SubPackages, on page 108](#)
- [Additional References, on page 117](#)
- [Feature Information for Consolidated Packages and SubPackages Management, on page 117](#)

## Finding Feature Information

Your software release may not support all the features that are documented in this module. For the latest feature information and caveats, see the release notes for your platform and software release. The Feature Information Table at the end of this document provides information about the documented features and lists the releases in which each feature is supported.

Use Cisco Feature Navigator to find information about platform support and Cisco software image support. To access Cisco Feature Navigator, go to <http://tools.cisco.com/ITDIT/CFN/>. An account on <http://www.cisco.com/> is not required.

## Running the Cisco cBR Series Routers Using Individual and Optional SubPackages: An Overview

The Cisco cBR Series Converged Broadband Router can be configured to run using individual subpackages and optional subpackages.

When the router is configured to run using individual and optional subpackages:

- Each individual subpackage within a consolidated package is extracted onto the router as its own file.
- Additionally, any optional subpackages must be separately downloaded and stored in the same directory with the provisioning file and the other individual subpackages that have been extracted.
- The router then runs by accessing each file as needed for operational purposes. All individual and optional subpackage files must be stored in the same directory on the router for the router to run properly using individual subpackages.

When the router runs using the individual and optional subpackages, the router needs to be configured to boot using the provisioning file that was included in the consolidated package with the individual subpackage files. This provisioning file must also be in the same directory as the individual and optional subpackage files. The router boots faster when configured to run using individual and optional subpackages than it does when configured to run using a consolidated package.

A Cisco cBR Series Router cannot be configured to run individual and optional subpackages stored on a TFTP or any other network server. To use this method of running the router, copy the individual and optional subpackages along with the provisioning file onto the bootflash: file system.

## Running the Cisco cBR Series Routers Using a Consolidated Package: An Overview

The Cisco cBR Series Converged Broadband Router can also be configured to run using a consolidated package.



---

**Note** Booting the router from a consolidated package is not supported for installation of optional subpackages.

---

When the router is configured to run using a consolidated package, the entire consolidated package file is copied onto the router or accessed by the router via TFTP or another network transport method. The router runs using the consolidated package file.

A router configured to run using a consolidated package is booted by booting the consolidated package file. Because this file is large, the boot process for routers running using the consolidated package is slower than the boot process for routers running individual subpackages.

A router configured to run using a consolidated package does have some advantages over a router configured to run individual subpackages. First, a consolidated package can be booted and utilized using TFTP or another network transport method. Secondly, configuring the router to use the one consolidated package file is easier than managing several individual subpackage files. Running the router using a consolidated package may be the right method of running the router in certain networking environments.

The consolidated package should be stored on bootflash:, usb[0-1]:, or a remote file system when this method is used to run the router.

## Running the Cisco cBR Series Routers: A Summary

The advantages of running your router using individual subpackages include:

- The router boots fastest when booted using the individual subpackage boot approach.
- Individual subpackages can be upgraded instead of the complete consolidated image.

The advantages of running your router using a consolidated package include:

- Simplified installation—Only one software file needs to be managed instead of several separate images.
- Storage—A consolidated package, unlike individual subpackages, can be used to run the router while being stored in bootflash:, on a USB Flash disk, or on a network server. A consolidated package can be booted and utilized using TFTP or another network transport method, while the individual subpackage method requires the individual subpackage files to be copied into the bootflash: file directory on the router.

Approach	Advantages	Disadvantages
Individual and optional subpackages <b>Note</b> This method is required if you need to install any optional subpackages for your system.	Faster boot time.	<ul style="list-style-type: none"> <li>• Multiple software subpackages more difficult to manage.</li> <li>• Cannot be booted from TFTP or any other network server. If you are going to use the individual subpackage boot method, each individual subpackage file must be placed in the bootflash: directory.</li> <li>• Individual and optional subpackage files and the provisioning file must be stored in bootflash:.</li> </ul>
Consolidated Package	<ul style="list-style-type: none"> <li>• Easier management. Only have to manage one file instead of many files.</li> <li>• A consolidated package file can be stored in bootflash:, on any TFTP or other network server.</li> </ul>	Slower boot times and lessened maximum system scalability because the larger image must be processed at all times.

## Software File Management Using Command Sets

Software files can be managed on the Cisco cBR Series Converged Broadband Router using the following distinct command sets.

### The request platform Command Set

The **request platform software package** command is part of the larger request platform command set being introduced on the Cisco cBR Series Converged Broadband Router.

The **request platform software package** command, which can be used to upgrade individual subpackages and a complete consolidated package, is used to upgrade software on the Cisco cBR Series Converged Broadband Router. Notably, the **request platform software package** command is the recommended way of performing an individual subpackage upgrade, and also provides the only method of no-downtime upgrades of individual subpackages on the router when the router is running individual subpackages.

The **request platform software package** command requires that the destination device or process be specified in the command line, so the commands can be used to upgrade software on both an active or a standby processor.

#### Command Syntax

**request platform software package install rp *rp-slot-number* file *file-URL***

where

- *rp-slot-number* is the number of the RP slot and
- *file-URL* is the path to the file being used to upgrade the Router.

### The copy Command

The **copy** command can be used to move consolidated packages and individual subpackages onto the router, though using this command to move individual subpackage files from one storage area to another is often inefficient (in these scenarios, it is almost always preferable to move the consolidated package, then extract the subpackages, or to extract the subpackages without moving the consolidated package).

To upgrade a consolidated package on the Cisco cBR Series Converged Broadband Router, copy the consolidated package onto a file system, usually bootflash: , using the **copy** command as you would on most other Cisco routers. After making this copy, configure the router to boot using the consolidated package file.

To upgrade the router and reboot using individual subpackages, copy the consolidated package onto the router using the **copy** command, enter the **request platform software package expand** command to extract the individual subpackages, and configure the router to boot using subpackages. Other methods, such as copying each individual subpackage in the same consolidated package from a directory or using the request platform software package command to extract the subpackages onto a router directory are also usable, though copying individual subpackages is often inefficient.

## Managing and Configuring the Router to Run Using Consolidated Packages and Individual SubPackages

This section describes methods that are used to manage and configure the packages, sub-packages and patches on the router.

## Cable Line Card Process Restart

The last step, in many of the methods used to upgrade and manage the packages and sub-packages, is to reload the router or the component for which the software is being configured or upgraded. Reloading the router or the components involves the following disadvantages:

- service disruption (limited)
- loss of modem configuration data
- time consumption in rebooting the line cards and other components

The N+1 line card high availability (LCHA) system reboots the active and the standby line cards whenever a package is upgraded on a line card. This occurs for sub-package upgrade for Field Replaceable Units (FRUs) on the line card as well. Every time an upgrade is done to a package or sub-package, the line card must be rebooted. The time taken for the package upgrade on N number of active line cards, the total number of reboots would be 2xN. This is time-consuming and may affect services on the rebooting line cards.

To avoid the disadvantages of reloading the router and the line cards, use the Cable Line Card Process Restart features when you upgrade packages on the RF line cards.



---

**Note** Do not use the process restart features without upgrading or installing packages on the RF line cards.

---

Primarily there are two features that allow you to restart Cable Line Card processes:

- Cable Line Card Control Plane Process Restart
- Cable Line Card Upstream Scheduler Process Restart

## Cable Line Card Control Plane Process Restart

The Cable Line Card Control Plane Process Restart feature provides the following advantages:

- Simplified package upgrade without LCHA based reboot of active and standby line cards.
- Restart of specific processes without service disruption.
- All the modem configuration data is recovered after the IOSd process restarts.
- Changes in the modem configuration data during the IOSd process restart is reconciled after the IOSd process is restarted.
- The secondary line card shutdown and un-shutdown processes occur automatically.

### Restrictions:

- To upgrade a line card IOS using the Cable Line Card Control Plane Process Restart feature, the sub-package must have the patches for cbrsup-clcios and cbrsup-clciosdb.
- IOSd and us-scheduler restart are supported. You can restart IOSd only, which requires IOSd/IOSdb packages or restart the us-scheduler only, which requires clc-docsis package. You can also restart both using a single command, where the us-scheduler is restarted first and then the IOSd is restarted. In this case, IOSd/IOSdb and clc-docsis packages are required.

Other restrictions include the following:

- The IOSd process can be restarted only on the primary active RF line cards.
- Any secondary RF line card must be shut down before restarting the IOSd process.
- The IOSd process restart does not work when double failures (i.e. termination of IOSd and one or more process at the same time) occur. The double failures result in line card reload.
- The restart of the next IOSd (i.e. IOSd process on the next RF line card) does not occur until the current IOSd process recovers fully.

The Cable Line Card Control Plane Process Restart feature provides the following restart options:

- Restart a specific slot using the **request platform software process restart** command with the **slot slot number** option.
- Restart all the line cards without specifying a specific slot, using the **request platform software process restart** command without the **slot slot number** option.
- Interval based restart option of all line card using the **request platform software process restart** command with the **interval secs** option.

Important points to remember:

- Before using the Cable Line Card Control Plane Process Restart feature, shut down the secondary line card, using the **hw-module slot shutdown** command.
- When the Cable Line Card Control Plane Process Restart feature is started, the secondary line card shuts down automatically.
- Before using the Cable Line Card Control Plane Process Restart feature, shut down the secondary line card, using the **hw-module slot shutdown** command.
- When the Cable Line Card Control Plane Process Restart feature is started, the secondary line card shuts down automatically.
- To prevent reloading the line card after sub-package upgrade, use the **request platform software package install node file** command with the **noreload linecard** option.
- Verify the restart process using the **show platform software ios slot slot number restart info** command.

## Restart on Crash

The cable line card control plane and upstream scheduler process restarts automatically after a crash. After restarting process, secondary line card is reset.

### Restrictions:

- Restart on crash supported only on primary active line cards

The table below lists the cable line card behaviors when crash happens under different rules.

Table 12: Cable Line Card Process Restart Policy Matrix

	Secondary Cable Line Card Present	Crash	Secondary Cable Line Card state
LCHA or LCPR	Yes	Cable line card reset	Active after switchover
Process restart enabled	No	Restart	N/A
LCHA or LCPR	Yes	Cable line card reset	Active after switchover
Process restart Disabled	No	Cable line card reset	N/A
No LCHA Preferred or LCPR	Yes	Process restart	Secondary cable line card resets after process restart on primary cable line card
Process restart Enabled	No	Process restart	N/A
No LCHA Preferred or LCPR	Yes	Cable line card reset	Active after switchover
Process restart Disabled	No	Cable line card reset	N/A

**Note**

- Manual process restart does not depend on policy configured, and will shut/unshut secondary cable line card if present.
- “LCHA preferred” and “process restart enable” are default. User can set these two parameters using `disable-auto-restart` and `lcha-preferred` commands. For the details, see [http://www.cisco.com/c/en/us/td/docs/cable/cmts/cmd\\_ref/b\\_cmts\\_cable\\_cmd\\_ref.html](http://www.cisco.com/c/en/us/td/docs/cable/cmts/cmd_ref/b_cmts_cable_cmd_ref.html).
- Behavior is the same for Control Plane Process Restart and Upstream Scheduler Process Restart.
- Secondary cable line card in standby mode is considered present.

The restart retry limit feature is added to the Cable Line Card Process Restart, it is applicable only to restart on crash. Using this feature, the customer can set a restart retry time limit, if the process cannot restart successfully within this limit, the line card will reload. This feature can prevent the line card from continuous restart when restart failed.

## Enhancements for LCHA Associated with DPIC Interfaces

Table 13: Feature History

Feature Name	Release Information	Feature Description
Enhancements for LCHA Associated with DPIC Interfaces	Cisco IOS XE Dublin 17.12.1w	In this release, the robustness of LCHA associated with DPIC interfaces is enhanced. This enhancement decouples the downstream queue in SUP and DPIC interface datapath change during LCHA. This ensures that RPDs on the line card stay online even if the active SUP is experiencing a stuck queue event. See <a href="#">show platform hardware qfp active cable dpic-lcha if-name</a> .

### Using the Cable Line Card Control Plane Process Restart Feature

To use the Cable Line Card Control Plane Process Restart Feature, install the RF line card sub-package upgrade using the command.

**Step 1** Install the RF line card sub-package upgrade using the **request platform software package install node file noreload linecard** command.

```
Router#request platform software package install node file bootflash:sp/cbr_patch.9.0.tar noreload linecard
```

**Step 2** Use the **request platform software process restart** command to restart the RF line card IOSd process on all the cable line cards sequentially.

```
Router# request platform software process restart
```

**Step 3** Use the **request platform software process restart slot slot#** command to restart the RF line card IOSd process on a specific cable line card.

```
Router# request platform software process restart slot 7
```

### Configuring the Cable Line Card Control Plane Process Restart Retry Limit

To configure the Cable Line Card Control Plane Process Restart Retry Limit, complete the following procedure:

```
enable
configure terminal
process-restart
lc-control-plane-timeout time
restart-retry retry-times
exit
```



## Examples for Cable Line Card Control Plane Process Restart Feature

This section provides the sample outputs for the commands used in the Cable Line Card Control Plane Process.

This example shows the output of the **request platform software package install node file** command with the **noreload linecard** option that installs the sub-package upgrade:

```
Router# request platform software package install node file bootflash:sp/cbr_patch.9.0.tar
noreload linecard
Image file expanded and copied
Expanding image file: stby-bootflash:sp/cbr_patch.9.0.tar
Image file expanded and copied
Finished image file expansion
Found clc package
STAGE 1: Installing software on standby RP
=====
--- Starting local lock acquisition on R0 ---
Finished local lock acquisition on R0
--- Starting installation state synchronization ---
Finished installation state synchronization
--- Starting local lock acquisition on R1 ---
Finished local lock acquisition on R1
--- Starting file path checking ---
Finished file path checking
--- Starting image file verification ---
Checking image file names
Locating image files and validating name syntax
Found cbrsup-clcios.2015-03-23_17.53_haolin2.SSA.pkg
Found cbrsup-clciosdb.2015-03-23_17.53_haolin2.SSA.pkg
Verifying image file locations
Inspecting image file types
Processing image file constraints
Creating candidate provisioning file
Finished image file verification
--- Starting candidate package set construction ---
Verifying existing software set
Processing candidate provisioning file
Constructing working set for candidate package set
Constructing working set for running package set
Checking command output
Constructing merge of running and candidate packages
Checking if resulting candidate package set would be complete
Finished candidate package set construction
--- Starting ISSU compatibility verification ---
Verifying image type compatibility
Checking IPC compatibility with running software
Checking candidate package set infrastructure compatibility
Checking infrastructure compatibility with running software
Checking package specific compatibility
Finished ISSU compatibility verification
--- Starting list of software package changes ---
Old files list:
Removed cbrsup-clcios.2015-03-23_17.28_haolin2.SSA.pkg
Removed cbrsup-clciosdb.2015-03-23_17.28_haolin2.SSA.pkg
New files list:
Added cbrsup-clcios.2015-03-23_17.53_haolin2.SSA.pkg
Added cbrsup-clciosdb.2015-03-23_17.53_haolin2.SSA.pkg
Finished list of software package changes
--- Starting commit of software changes ---
Updating provisioning rollback files
Creating pending provisioning file
Committing provisioning file
Finished commit of software changes
```

```

--- Starting analysis of software changes ---
Finished analysis of software changes
--- Starting update running software ---
Blocking peer synchronization of operating information
Creating the command set placeholder directory
Finding latest command set
Finding latest command shortlist lookup file
Finding latest command shortlist file
Assembling CLI output libraries
Assembling CLI input libraries
Assembling Dynamic configuration files
Applying interim IPC and database definitions
Replacing running software
Replacing CLI software
Restarting software
Restarting software: target frus filtered out ... skipped
Applying final IPC and database definitions
Generating software version information
Notifying running software of updates
Unblocking peer synchronization of operating information
Unmounting old packages
Cleaning temporary installation files
Finished update running software
SUCCESS: Finished installing software.
STAGE 2: Installing software on active RP
=====
--- Starting local lock acquisition on R0 ---
Finished local lock acquisition on R0
--- Starting installation state synchronization ---
Finished installation state synchronization
--- Starting file path checking ---
Finished file path checking
--- Starting image file verification ---
Checking image file names
Locating image files and validating name syntax
Found cbrsup-clcios.2015-03-23_17.53_haolin2.SSA.pkg
Found cbrsup-clciosdb.2015-03-23_17.53_haolin2.SSA.pkg
Verifying image file locations
Inspecting image file types
Processing image file constraints
Creating candidate provisioning file
Finished image file verification
--- Starting candidate package set construction ---
Verifying existing software set
Processing candidate provisioning file
Constructing working set for candidate package set
Constructing working set for running package set
Checking command output
Constructing merge of running and candidate packages
Checking if resulting candidate package set would be complete
Finished candidate package set construction
--- Starting ISSU compatibility verification ---
Verifying image type compatibility
Checking IPC compatibility with running software
Checking candidate package set infrastructure compatibility
Checking infrastructure compatibility with running software
Checking package specific compatibility
Finished ISSU compatibility verification
--- Starting impact testing ---
Checking operational impact of change
Finished impact testing
--- Starting list of software package changes ---
Old files list:
Removed cbrsup-clcios.2015-03-23_17.28_haolin2.SSA.pkg

```

```

Removed cbrsup-clciosdb.2015-03-23_17.28_haolin2.SSA.pkg
New files list:
Added cbrsup-clcios.2015-03-23_17.53_haolin2.SSA.pkg
Added cbrsup-clciosdb.2015-03-23_17.53_haolin2.SSA.pkg
Finished list of software package changes
--- Starting commit of software changes ---
Updating provisioning rollback files
Creating pending provisioning file
Committing provisioning file
Finished commit of software changes
--- Starting analysis of software changes ---
Finished analysis of software changes
--- Starting update running software ---
Blocking peer synchronization of operating information
Creating the command set placeholder directory
Finding latest command set
Finding latest command shortlist lookup file
Finding latest command shortlist file
Assembling CLI output libraries
Assembling CLI input libraries
Assembling Dynamic configuration files
Applying interim IPC and database definitions
Replacing running software
Replacing CLI software
Restarting software
Restarting software: target frus filtered out ... skipped
Applying final IPC and database definitions
Generating software version information
Notifying running software of updates
Unblocking peer synchronization of operating information
Unmounting old packages
Cleaning temporary installation files
Finished update running software
SUCCESS: Finished installing software.
Found clc package
SUCCESS: node ISSU finished successfully.
Invoking cleanup routine

```

This example shows the output of the **show platform software ios restart info** command:

```

Router#show platform software ios 6 restart info
IOSD process restart info:
Process restartable: Yes
IOSD restart state : ACTIVE
Total Modem Count : 31
Active Modem Count : 31

```

This example shows the output of the **request platform software process restart** command:

```

Router# request platform software process restart
--- Upgrading/Restarting LineCard-2 Packages/Processes ---
NOTICE: No upgrades available.
Provide process name in cli if you wish to restart a process
--- Upgrading/Restarting LineCard-3 Packages/Processes ---
Available upgrades
cbrsup-clcios.2015-03-23_17.53_haolin2.SSA.pkg
cbrsup-clciosdb.2015-03-23_17.53_haolin2.SSA.pkg
--- Checking for ready state before IOSD upgrade on LineCard-3
Updating Package cbrsup-clcios.2015-03-23_17.28_haolin2.SSA.pkg

```

```

---> cbrsup-clcios.2015-03-23_17.53_haolin2.SSA.pkg
Restarting ubrclc_k9lc_ms
--- Checking for ready state before IOSDB upgrade on LineCard-3
Updating Package cbrsup-clciosdb.2015-03-23_17.28_haolin2.SSA.pkg
---> cbrsup-clciosdb.2015-03-23_17.53_haolin2.SSA.pkg
Restarting iosdb
SUCCESS: Finished

```

```

Router#show platform software patch 2 info
cbrsup-clciosdb: 3.17.0 (3.0)
cbrsup-clc-firmware: 3.17.0 (0.0)
cbrsup-clcvideo: 3.17.0 (0.0)
cbrsup-clcios: 3.17.0 (3.0)
cbrsup-clccontrol: 3.17.0 (0.0)
cbrsup-clcdocsis: 3.17.0 (0.0)

```

## Cable Line Card Upstream Scheduler Process Restart

The Cable Line Card Upstream Scheduler Process Restart feature is used to restart the upstream scheduler process on the RF line cards.

The Cable Line Card Upstream Scheduler Process Restart feature provides the following advantages:

- Allows to restart line card US- Scheduler (CDMAN) process with minimum impact to upstream traffic and no impact to downstream traffic.
- All modem configuration data recovered to the state before restart.
- Changes in modem configuration data during restart are reconciled.
- New modems coming online are blocked during restart.
- The **request platform software package restart** command is used to upgrade the new DOCSIS sub-pkg patch without reloading the line card.
- Effective with Cisco IOS-XE Release 3.18.0S, the card restarts automatically after a crash. For more information, see [Restart on Crash, on page 90](#) section.

### Restrictions:

The following restrictions apply to the :

- The Upstream Scheduler process can be restarted only on the primary active RF line cards.
- The Upstream Scheduler process restart does not work when double failures (i.e. termination of Upstream Scheduler and one or more process at the same time) occur. The double failures result in line card reload.
- The restart of the next Upstream Scheduler (i.e. Upstream Scheduler process on the next RF line card) does not occur until the current Upstream Scheduler process recovers fully.

Important points to remember:

- With Cisco IOS-XE Release 3.17.0S, when the Cable Line Card Upstream Scheduler Process Restart feature is started, the secondary line card shuts down automatically.
- To prevent reloading the line card after sub-package upgrade, use the **request platform software package install node file** command with the **noreload linecard** option.
- Verify the restart process using the **show platform software us-scheduler restart info** command.

```
Router# show platform software us-scheduler 3 restart info
us-scheduler process restart info:
Process restartable : Yes
us-scheduler state : RESTART_OPERATIONAL
Features bit map : 0x001e
us-scheduler restart count : 4
```

## Using the Cable Line Card Upstream Scheduler Process Restart Feature

To use the Cable Line Card Upstream Scheduler Process Restart Feature, install the RF line card sub-package upgrade using the command.

- Step 1** Install the RF line card sub-package upgrade using the **request platform software package install node file noreload linecard** command.

```
Router#request platform software package install node file bootflash:sp/cbr_patch.9.0.tar noreload
linecard
```

- Step 2** Use the **request platform software process restart** command to restart the Upstream Scheduler process on all the cable line cards sequentially.

```
Router# request platform software process restart
```

- Step 3** Use the **request platform software process restart slot slot#** command to restart the Upstream Scheduler process on a specific cable line card.

```
Router# request platform software process restart slot 7
```

## Configuring the Cable Line Card Control Plane Process Restart Retry Limit

To configure the Cable Line Card Control Plane Process Restart Retry Limit, complete the following procedure:

```
enable
configure terminal
process-restart
lc-us-scheduler-timeout time
restart-retry retry-times
exit
```

## Examples for Cable Line Card Upstream Scheduler Process Restart Feature

This section provides the sample outputs for the commands used in the Cable Line Card Upstream Scheduler Process Restart Feature.

This example shows the output of the **show platform software us-scheduler restart info** command.

```
Router#show platform software us-scheduler 6 restart info
us-scheduler process restart info:
```

```

Process restartable : Yes
us-scheduler state : RESTART_OPERATIONAL
Features bit map : 0x001e
us-scheduler restart count : 1

```

This example shows the output when the upstream scheduler process is restarted.

```

Router# request platform software package install node file
bootflash:subpkg/cbr_patch-3.17.0-patch2.tar noreload linecard
NOTE: Currently node has booted from a provisioning file
NOTE: Going to start a dual rp sub-packages node ISSU install
--- Starting initial file path checking --- Copying
bootflash:subpkg/cbr_patch-3.17.0-patch2.tar to
stby-bootflash:subpkg/cbr_patch-3.17.0-patch2.tar
Finished initial file path checking
--- Starting config-register verification --- Finished config-register verification
--- Starting Checking noreload options --- Finished Checking noreload options
--- Starting image file expansion ---
Expanding image file: bootflash:subpkg/cbr_patch-3.17.0-patch2.tar
Image file expanded and copied
Expanding image file: stby-bootflash:subpkg/cbr_patch-3.17.0-patch2.tar
Image file expanded and copied
Finished image file expansion
Found clc package
STAGE 1: Installing software on standby RP =====
--- Starting local lock acquisition on R0 --- Finished local lock acquisition on R0
--- Starting installation state synchronization --- Finished installation state
synchronization
--- Starting local lock acquisition on R1 --- Finished local lock acquisition on R1
--- Starting file path checking ---
Finished file path checking
--- Starting image file verification --- Checking image file names Locating image files and
validating name syntax
Found cbrsup-clcdocsis.2015-10-08_18.10_haolin2.SSA.pkg
Verifying image file locations
Inspecting image file types
Processing image file constraints
Creating candidate provisioning file
Finished image file verification
--- Starting candidate package set construction --- Verifying existing software set Processing
candidate provisioning file Constructing working set for
candidate package set Constructing working set for running package set Checking command
output Constructing merge of running and candidate packages
Checking if resulting candidate package set would be complete Finished candidate package
set construction
--- Starting ISSU compatibility verification ---
WARNING:
WARNING: ISSU between engineering builds with release strings in non-standard fo rmat.
Skipping ISSU Software Compatibility checks.
WARNING:
WARNING:
WARNING: ISSU between engineering builds with release strings in non-standard fo rmat.
Skipping ISSU Software Compatibility checks.
WARNING:
WARNING:
WARNING: ISSU between engineering builds with release strings in non-standard fo rmat.
Skipping ISSU Software Compatibility checks.
WARNING:
WARNING:
WARNING: ISSU between engineering builds with release strings in non-standard fo rmat.
Skipping ISSU Software Compatibility checks.
WARNING:
WARNING:
WARNING: ISSU between engineering builds with release strings in non-standard fo rmat.
Skipping ISSU Software Compatibility checks.
WARNING:

```

```

Verifying image type compatibility
Checking IPC compatibility with running software Checking candidate package set infrastructure
compatibility Checking infrastructure compatibility with running
software Checking package specific compatibility Finished ISSU compatibility verification
--- Starting list of software package changes --- Old files list:
Removed cbrsup-clcdocsis.BLD_MCP_DEV_LATEST_20151006_133623.SSA.pkg
New files list:
Added cbrsup-clcdocsis.2015-10-08_18.10_haolin2.SSA.pkg
Finished list of software package changes
--- Starting commit of software changes --- Updating provisioning rollback files Creating
pending provisioning file Committing provisioning file Finished
commit of software changes
--- Starting analysis of software changes --- Finished analysis of software changes
--- Starting update running software --- Blocking peer synchronization of operating
information Creating the command set placeholder directory
Finding latest command set
Finding latest command shortlist lookup file
Finding latest command shortlist file
Assembling CLI output libraries
Assembling CLI input libraries
Assembling Dynamic configuration files
Applying interim IPC and database definitions
Replacing running software
Replacing CLI software
Restarting software
Restarting software: target frus filtered out ... skipped
Applying final IPC and database definitions
Generating software version information
Notifying running software of updates
Unblocking peer synchronization of operating information Unmounting old packages Cleaning
temporary installation files
Finished update running software
SUCCESS: Finished installing software.
STAGE 2: Installing software on active RP =====
--- Starting local lock acquisition on R0 --- Finished local lock acquisition on R0
--- Starting installation state synchronization --- Finished installation state
synchronization
--- Starting file path checking ---
Finished file path checking
--- Starting image file verification --- Checking image file names Locating image files and
validating name syntax
Found cbrsup-clcdocsis.2015-10-08_18.10_haolin2.SSA.pkg
Verifying image file locations
Inspecting image file types
Processing image file constraints
Creating candidate provisioning file
Finished image file verification
--- Starting candidate package set construction --- Verifying existing software set Processing
candidate provisioning file Constructing working set for candidate
package set Constructing working set for running package set Checking command output
Constructing merge of running and candidate packages Checking if resulting
candidate package set would be complete Finished candidate package set construction
--- Starting ISSU compatibility verification ---
WARNING:
WARNING: ISSU between engineering builds with release strings in non-standard fo rmat.
Skipping ISSU Software Compatibility checks.
WARNING:
WARNING:
WARNING: ISSU between engineering builds with release strings in non-standard fo rmat.
Skipping ISSU Software Compatibility checks.
WARNING:
WARNING:
WARNING: ISSU between engineering builds with release strings in non-standard fo rmat.
Skipping ISSU Software Compatibility checks.

```

```

WARNING:
WARNING:
WARNING: ISSU between engineering builds with release strings in non-standard fo rmat.
Skipping ISSU Software Compatibility checks.
WARNING:
Verifying image type compatibility
Checking IPC compatibility with running software Checking candidate package set infrastructure
compatibility Checking infrastructure compatibility with running
software Checking package specific compatibility Finished ISSU compatibility verification
--- Starting impact testing ---
Checking operational impact of change
Finished impact testing
--- Starting list of software package changes --- Old files list:
Removed cbrsup-clcdocsis.BLD_MCP_DEV_LATEST_20151006_133623.SSA.pkg
New files list:
Added cbrsup-clcdocsis.2015-10-08_18.10_haolin2.SSA.pkg
Finished list of software package changes
--- Starting commit of software changes --- Updating provisioning rollback files Creating
pending provisioning file Committing provisioning file Finished
commit of software changes
--- Starting analysis of software changes --- Finished analysis of software changes
--- Starting update running software --- Blocking peer synchronization of operating
information Creating the command set placeholder directory
Finding latest command set
Finding latest command shortlist lookup file
Finding latest command shortlist file
Assembling CLI output libraries
Assembling CLI input libraries
Assembling Dynamic configuration files
Applying interim IPC and database definitions
Replacing running software
Replacing CLI software
Restarting software
Restarting software: target frus filtered out ... skipped
Applying final IPC and database definitions
Generating software version information
Notifying running software of updates
Unblocking peer synchronization of operating information Unmounting old packages Cleaning
temporary installation files
Finished update running software
SUCCESS: Finished installing software.
Found clc package
SUCCESS: node ISSU finished successfully.
Invoking cleanup routine
Router#

Router#show platform software us-scheduler 2 restart info
us-scheduler process restart info:
Process restartable : Yes
us-scheduler state : RESTART_OPERATIONAL
Features bit map : 0x001e
us-scheduler restart count : 1

Router#request platform software process restart slot 2
--- Upgrading/Restarting LineCard-2 Packages/Processes ---
Available upgrades
cbrsup-clcdocsis.BLD_MCP_DEV_LATEST_20151006_13362
Updating Package cbrsup-clcdocsis.BLD_MCP_DEV_LATEST_20151006_13362
--> cbrsup-clcdocsis.2015-10-08_18.10_haolin2.SSA.pkg
Restarting us-scheduler
SUCCESS: Finished upgrading the LineCard-2

Router#show platform software patch 2 info
cbrsup-clciosdb: 3.17.0 (0.0)

```



```

cbrsup-clc-firmware: 3.17.0 (0.0)
cbrsup-clcvideo: 3.17.0 (0.0)
cbrsup-clcios: 3.17.0 (0.0)
cbrsup-clccontrol: 3.17.0 (0.0)
cbrsup-clcdocsis: 3.17.0 (2.0)

```



**Note** If the upgrade package includes both IOSD-CLC and US-scheduler sub-packages, the **request platform software process restart** command first restarts the Cable Line Card Upstream Scheduler process and then the Cable Line Card Control Plane process.

This example shows the output of the **request platform software process restart** command when the Control Plane and the upstream scheduler process are restarted:



**Note** If the **slot** keyword is not used, the upstream scheduler process on all the line cards are restarted sequentially.

```

Router#request platform software process restart

--- Upgrading/Restarting LineCard-1 Packages/Processes ---

Available upgrades
  cbrsup-clcdocsis.2015-09-24_03.09_johuynh.SSA.pkg
  cbrsup-clcios.2015-09-24_03.09_johuynh.SSA.pkg
  cbrsup-clciosdb.2015-09-24_03.09_johuynh.SSA.pkg

Updating Package  cbrsup-clcdocsis.2015-09-24_03.09_johuynh.SSA.pkg
  ---> cbrsup-clcdocsis.2015-09-24_19.04_haolin2.SSA.pkg
Restarting us-scheduler
--- Checking for ready state before IOSD upgrade on LineCard-1
Updating Package  cbrsup-clcios.2015-09-24_03.09_johuynh.SSA.pkg
  ---> cbrsup-clcios.2015-09-24_19.04_haolin2.SSA.pkg
Restarting ubrclc_k9lc_ms
--- Checking for ready state before IOSDB upgrade on LineCard-1
Updating Package  cbrsup-clciosdb.2015-09-24_03.09_johuynh.SSA.pkg
  ---> cbrsup-clciosdb.2015-09-24_19.04_haolin2.SSA.pkg
Restarting iosdb

SUCCESS: Finished upgrading the LineCard-1

--- Upgrading/Restarting LineCard-2 Packages/Processes ---

Available upgrades
  cbrsup-clcdocsis.2015-09-24_03.09_johuynh.SSA.pkg
  cbrsup-clcios.2015-09-24_03.09_johuynh.SSA.pkg
  cbrsup-clciosdb.2015-09-24_03.09_johuynh.SSA.pkg

Updating Package  cbrsup-clcdocsis.2015-09-24_03.09_johuynh.SSA.pkg
  ---> cbrsup-clcdocsis.2015-09-24_19.04_haolin2.SSA.pkg
Restarting us-scheduler
--- Checking for ready state before IOSD upgrade on LineCard-2
Updating Package  cbrsup-clcios.2015-09-24_03.09_johuynh.SSA.pkg
  ---> cbrsup-clcios.2015-09-24_19.04_haolin2.SSA.pkg
Restarting ubrclc_k9lc_ms
--- Checking for ready state before IOSDB upgrade on LineCard-2

```

```

Updating Package  cbrsup-clciosdb.2015-09-24_03.09_johuynh.SSA.pkg
                ---> cbrsup-clciosdb.2015-09-24_19.04_haolin2.SSA.pkg
Restarting iosdb

SUCCESS: Finished upgrading the LineCard-2
Router#

```

You can specify a time interval in seconds using the **interval** keyword, between the restarting of two line card processes in the sequence. The default interval is five seconds.

This example shows the configuration of an interval of six seconds.

```
Router#request platform software process restart interval 6
```

## Quick Start Software Upgrade

The following instructions provide a quick start version of upgrading the software running the Cisco cBR Series Converged Broadband Router. These instructions assume you have access to the consolidated package and that the files will be stored in a bootflash: file system that is not storing any previously installed subpackages or consolidated packages and that has enough room for the file or files.

- 
- Step 1** Copy the consolidated package into bootflash: using the **copy URL-to-image bootflash:** command.
  - Step 2** If you want to run the router using individual subpackages, enter the **request platform software package expand file bootflash:/sub\_dir/base\_image** command. If you want to run the router using a consolidated package, skip this step.
  - Step 3** Enter the **dir bootflash:** command to verify your consolidated package or your extracted subpackages are in the directory.
  - Step 4** If you are trying to run individual subpackages, use the **delete bootflash:base\_image** to delete the consolidated package. If you want to run the router using the consolidated package, skip this step.
  - Step 5** Set up the boot parameters for your boot. Set the configuration register to 0x2 by entering the **config-register 0x2102** global configuration command, and enter the **boot system flash bootflash:base\_image** (if running using the consolidated package) or **boot system flash bootflash:provisioning-file-name** (if running using individual subpackages) global configuration command.
  - Step 6** Enter **copy running-config startup-config** to save your configuration.
  - Step 7** Enter the **reload** command to reload the router and finish the boot. The upgraded software should be running when the reload completes.
- 

## Managing and Configuring a Consolidated Package Using the copy Command

To upgrade a consolidated package on the Cisco cBR Series Routers using the **copy** command, copy the consolidated package into the bootflash: directory on the router using the **copy** command as you would on most other Cisco routers. After making this copy, configure the router to boot using the consolidated package file.

In the following example, the consolidated package file is copied onto the bootflash: file system from TFTP. The config-register is then set to boot using **boot system** commands, and the **boot system** commands instruct the router to boot using the consolidated package stored in the bootflash: file system. The new configuration

is then saved using the `copy running-config startup-config` command, and the system is then reloaded to complete the process.

```

Router# dir bootflash:
Directory of bootflash:/

11 drwx 16384 Dec 4 2007 04:32:46 -08:00 lost+found
86401 drwx 4096 Dec 4 2007 06:06:24 -08:00 .ssh
14401 drwx 4096 Dec 4 2007 06:06:36 -08:00 .rollback_timer
28801 drwx 4096 Mar 18 2008 17:31:17 -07:00 .prst_sync
43201 drwx 4096 Dec 4 2007 04:34:45 -08:00 .installer
13 -rw- 45977 Apr 9 2008 16:48:46 -07:00 target_support_output.tgz.tgz

928862208 bytes total (712273920 bytes free)

Router# copy tftp bootflash:
Address or name of remote host []? 172.17.16.81
Source filename []?
/autotftp-users/user/cbrsup-universal*.bin Destination filename [cbrsup-universal*.bin]?
Accessing
tftp://172.17.16.81/autotftp-users/user/ cbrsup-universal*.bin...

Loading /autotftp-users/user/cbrsup-universal*.bin from
172.17.16.81 (via GigabitEthernet0):
!!!!!!!!!!!!!!!!!!!!!!!!!!!!!!!!!!!!!!!!!!!!!!!!!!!!!!!!!!!!!!!!!!!!!!!!!!!!!!!!!!!!!!!!!!!!!!!!!!!!!!!!!!!!!!!!!!!!!!!!
!!!!!!!!!!!!!!!!!!!!!!!!!!!!!!!!!!!!!!!!!!!!!!!!!!!!!!!!!!!!!!!!!!!!!!!!!!!!!!!!!!!!!!!!!!!!!!!!!!!!!!!!!!!!!!!!!!!!!!!!
!!!!!!!!!!!!!!!!!!!!!!!!!!!!!!!!!!!!!!!!!!!!!!!!!!!!!!!!!!!!!!!!!!!!!!!!!!!!!!!!!!!!!!!!!!!!!!!!!!!!!!!!!!!!!!!!!!!!!!!!
!!!!!!!!!!!!!!!!!!!!!!!!!!!!!!!!!!!!!!!!!!!!!!!!!!!!!!!!!!!!!!!!!!!!!!!!!!!!!!!!!!!!!!!!!!!!!!!!!!!!!!!!!!!!!!!!!!!!!!!!
!!!!!!!!!!!!!!!!!!!!!!!!!!!!!!!!!!!!!!!!!!!!!!!!!!!!!!!!!!!!!!!!!!!!!!!!!!!!!!!!!!!!!!!!!!!!!!!!!!!!!!!!!!!!!!!!!!!!!!!!
!!!!!!!!!!!!!!!!!!!!!!!!!!!!!!!!!!!!!!!!!!!!!!!!!!!!!!!!!!!!!!!!!!!!!!!!!!!!!!!!!!!!!!!!!!!!!!!!!!!!!!!!!!!!!!!!!!!!!!!!
!!!!!!!!!!!!!!!!!!!!!!!!!!!!!!!!!!!!!!!!!!!!!!!!!!!!!!!!!!!!!!!!!!!!!!!!!!!!!!!!!!!!!!!!!!!!!!!!!!!!!!!!!!!!!!!!!!!!!!!!
!!!!!!!!!!!!!!!!!!!!!!!!!!!!!!!!!!!!!!!!!!!!!!!!!!!!!!!!!!!!!!!!!!!!!!!!!!!!!!!!!!!!!!!!!!!!!!!!!!!!!!!!!!!!!!!!!!!!!!!!
!!!!!!!!!!!!!!!!!!!!!!!!!!!!!!!!!!!!!!!!!!!!!!!!!!!!!!!!!!!!!!!!!!!!!!!!!!!!!!!!!!!!!!!!!!!!!!!!!!!!!!!!!!!!!!!!!!!!!!!!
!!!!!!!!!!!!!!!!!!!!!!!!!!!!!!!!!!!!!!!!!!!!!!!!!!!!!!!!!!!!!!!!!!!!!!!!!!!!!!!!!!!!!!!!!!!!!!!!!!!!!!!!!!!!!!!!!!!!!!!!
!!!!!!!!!!!!!!!!!!!!!!!!!!!!!!!!!!!!!!!!!!!!!!!!!!!!!!!!!!!!!!!!!!!!!!!!!!!!!!!!!!!!!!!!!!!!!!!!!!!!!!!!!!!!!!!!!!!!!!!!
!!!!!!!!!!!!!!!!!!!!!!!!!!!!!!!!!!!!!!!!!!!!!!!!!!!!!!!!!!!!!!!!!!!!!!!!!!!!!!!!!!!!!!!!!!!!!!!!!!!!!!!!!!!!!!!!!!!!!!!!
!!!!!!!!!!!!!!!!!!!!!!!!!!!!!!!!!!!!!!!!!!!!!!!!!!!!!!!!!!!!!!!!!!!!!!!!!!!!!!!!!!!!!!!!!!!!!!!!!!!!!!!!!!!!!!!!!!!!!!!!
!!!!!!!!!!!!!!!!!!!!!!!!!!!!!!!!!!!!!!!!!!!!!!!!!!!!!!!!!!!!!!!!!!!!!!!!!!!!!!!!!!!!!!!!!!!!!!!!!!!!!!!!!!!!!!!!!!!!!!!!
!!!!!!!!!!!!

[OK - 208904396 bytes]

208904396 bytes copied in 330.453 secs (632176 bytes/sec)

Router# dir bootflash:
Directory of bootflash:/

11 drwx 16384 Dec 4 2007 04:32:46 -08:00 lost+found
86401 drwx 4096 Dec 4 2007 06:06:24 -08:00 .ssh
14401 drwx 4096 Dec 4 2007 06:06:36 -08:00 .rollback_timer
28801 drwx 4096 Mar 18 2008 17:31:17 -07:00 .prst_sync
43201 drwx 4096 Dec 4 2007 04:34:45 -08:00 .installer
12 -rw- 208904396 May 28 2008 16:17:34 -07:00
cbrsup-universal*.bin
13 -rw- 45977 Apr 9 2008 16:48:46 -07:00 target_support_output.tgz.tgz

928862208 bytes total (503156736 bytes free)

Router# config t
Enter configuration commands, one per line. End with CNTL/Z.
Router(config)#boot system flash
bootflash:cbrsup-universal*.bin
Router(config)#config-reg 0x2102
Router(config)#exit
Router#show run | include boot
boot-start-marker
boot system flash bootflash:cbrsup-universal*.bin boot-end-marker
Router# copy run start
Destination filename [startup-config]? Building configuration...

```

```
[OK]
Router# reload
```

## Managing and Configuring a Router to Run Using Individual SubPackages From a Consolidated Package

To run the router using individual subpackages from a consolidated package, follow one of the following procedures:

### Extracting a Consolidated Package and Booting Using the Provisioning File

To extract a consolidated package and to boot using provisioning file, perform the following steps:

**Step 1** Perform one of the following tasks:

- a) Copy the consolidated package file (or, in cases where you have every individual subpackage and a provisioning file for the subpackages available, each individual subpackage and the provisioning file) onto the bootflash: file system using the **copy** command. Make sure to copy the consolidated package into the bootflash: file system and directory where you want to store the provisioning file and the individual image subpackages. Enter the **request platform software package expand file bootflash:url-to-Cisco-IOS-XE-imagename** command with no other option to extract the provisioning file and the individual subpackages out of the consolidated package file and into the current directory in bootflash:. We recommend that you extract the sub packages to an empty directory to simplify the management of these files.
- b) Copy the consolidated package file onto any file system on your router, then enter the **request platform software package expand file file-system:url-to-Cisco-IOS-XE-imagename to bootflash:** command to extract the provisioning file and the individual image subpackages onto the bootflash: file system.

**Note** After performing this step, do not move any of the files. The bootup process cannot function properly unless all of the subpackages and the provisioning file are located in the same directory. Also, do not rename the subpackage files. Only the provisioning file can be renamed, and the renaming of the provisioning file, if desired, should be done at this step before the router is rebooted.

**Step 2** Configure the router to boot using the provisioning file.

The sequence below provides an example that would boot the router using the provisioning file named packages.conf that was stored with the other subpackages in the bootflash: file system:

```
Router(config)# no boot system
Router(config)# config-register 0x2102
Router(config)# boot system flash bootflash:packages.conf
Router(config)# exit
*May 11 01:31:04.815: %SYS-5-CONFIG_I: Configured from console by con
Router# copy running-config startup-config
Building configuration... [OK]
Router# reload
```

#### Extracting the SubPackages and the Provisioning File: Example 1

The following example shows how to extract the individual subpackages and the provisioning file from a consolidated package that has already been placed in the directory where you want to store the individual subpackages and the

provisioning file. We recommend that you extract the sub packages to an empty directory to simplify the management of these files.

Output of the directory before and after the extraction is given to confirm the files were extracted.

```
Router# dir bootflash:
Directory of bootflash:/

11 drwx 16384 Dec 4 2007 04:32:46 -08:00 lost+found
86401 drwx 4096 Dec 4 2007 06:06:24 -08:00 .ssh
14401 drwx 4096 Dec 4 2007 06:06:36 -08:00 .rollback_timer
28801 drwx 4096 Mar 18 2008 17:31:17 -07:00 .prst_sync
43201 drwx 4096 Dec 4 2007 04:34:45 -08:00 .installer
12 -rw- 208904396 May 9 2008 14:36:31 -07:00
cbrsup-universal*.bin
13 -rw- 45977 Apr 9 2008 16:48:46 -07:00 target_support_output.tgz.tgz

928862208 bytes total (503156736 bytes free)

Router# request platform software package expand file bootflash:cbrsup-universal*.bin
Verifying parameters
Validating package type
Copying package files
SUCCESS: Finished expanding all-in-one software package.

Router# dir bootflash:
Directory of bootflash:/

11 drwx 16384 Dec 4 2007 04:32:46 -08:00 lost+found
86401 drwx 4096 Dec 4 2007 06:06:24 -08:00 .ssh
14401 drwx 4096 Dec 4 2007 06:06:36 -08:00 .rollback_timer
28801 drwx 4096 Mar 18 2008 17:31:17 -07:00 .prst_sync
43201 drwx 4096 Dec 4 2007 04:34:45 -08:00 .installer
12 -rw- 208904396 May 9 2008 14:36:31 -07:00
cbrsup-universal*.bin
57611 -rw- 47071436 May 22 2008 11:26:23 -07:00 cbr000rp1-espbase.02.01.00.122-33.XNA.pkg
57602 -rw- 5740 May 22 2008 11:26:22 -07:00 cbr000rp1-packages-adventerprisek9.02.01.00.122-33.XNA.conf
57612 -rw- 20334796 May 22 2008 11:26:24 -07:00
cbr000rp1-rpaccess.02.01.00.122-33.XNA.pkg
57613 -rw- 22294732 May 22 2008 11:26:24 -07:00 cbr000rp1-rpbase.02.01.00.122-33.XNA.pkg
57614 -rw- 21946572 May 22 2008 11:26:25 -07:00 cbr000rp1-rpcontrol.02.01.00.122-33.XNA.pkg
57615 -rw- 48099532 May 22 2008 11:26:26 -07:00
cbr000rp1-rpios-adventerprisek9.02.01.00.122-33.XNA.pkg
57616 -rw- 34324684 May 22 2008 11:26:27 -07:00 cbr000rp1-sipbase.02.01.00.122-33.XNA.pkg
57617 -rw- 22124748 May 22 2008 11:26:28 -07:00 cbr000rp1-sipspace.02.01.00.122-33.XNA.pkg
57603 -rw- 6256 May 22 2008 11:26:28 -07:00 packages.conf
13 -rw- 45977 Apr 9 2008 16:48:46 -07:00 target_support_output.tgz.tgz

928862208 bytes total (286662656 bytes free)
```

## Extracting the SubPackages, Configuring the Router to Boot Using the Provisioning File, and Reloading the Router: Example 2

In the following example, the provisioning file and the individual subpackages are extracted from a consolidated package. The router is then configured to boot using the provisioning file. This example also shows the config-register being set and the running configuration being saved because these tasks must be performed for the router to reload properly. The router is then reloaded to complete the process.

```
Router# dir bootflash:
Directory of bootflash:/
```

```

11 drwx 16384 Dec 4 2007 04:32:46 -08:00 lost+found
86401 drwx 4096 Dec 4 2007 06:06:24 -08:00 .ssh
14401 drwx 4096 Dec 4 2007 06:06:36 -08:00 .rollback_timer
28801 drwx 4096 Mar 18 2008 17:31:17 -07:00 .prst_sync
43201 drwx 4096 Dec 4 2007 04:34:45 -08:00 .installer
12 -rw- 208904396 May 9 2008 14:36:31 -07:00
cbrsup-universal*.bin
13 -rw- 45977 Apr 9 2008 16:48:46 -07:00 target_support_output.tgz.tgz

```

```
928862208 bytes total (503156736 bytes free)
```

```

Router# request platform software package expand file bootflash:cbrsup-universal*.bin
Verifying parameters
Validating package type
Copying package files
SUCCESS: Finished expanding all-in-one software package.

```

```

Router# dir bootflash:
Directory of bootflash:/

```

```

11 drwx 16384 Dec 4 2007 04:32:46 -08:00 lost+found
86401 drwx 4096 Dec 4 2007 06:06:24 -08:00 .ssh
14401 drwx 4096 Dec 4 2007 06:06:36 -08:00 .rollback_timer
28801 drwx 4096 Mar 18 2008 17:31:17 -07:00 .prst_sync
43201 drwx 4096 Dec 4 2007 04:34:45 -08:00 .installer
12 -rw- 208904396 May 9 2008 14:36:31 -07:00
cbrsup-universal*.bin
57611 -rw- 47071436 May 22 2008 11:26:23 -07:00 cbr000rp1-espbase.02.01.00.122-33.XNA.pkg
57602 -rw- 5740 May 22 2008 11:26:22 -07:00
cbr000rp1-packages-adventerprisek9.02.01.00.122-33.XNA.conf
57612 -rw- 20334796 May 22 2008 11:26:24 -07:00 cbr000rp1-rpaccess.02.01.00.122-33.XNA.pkg
57613 -rw- 22294732 May 22 2008 11:26:24 -07:00 cbr000rp1-rpbase.02.01.00.122-33.XNA.pkg
57614 -rw- 21946572 May 22 2008 11:26:25 -07:00
cbr000rp1-rpcontrol.02.01.00.122-33.XNA.pkg
57615 -rw- 48099532 May 22 2008 11:26:26 -07:00 cbr000rp1-rpios-adventerprisek9.02.01.00.122-33.XNA.pkg
57616 -rw- 34324684 May 22 2008 11:26:27 -07:00 cbr000rp1-sipbase.02.01.00.122-33.XNA.pkg
57617 -rw- 22124748 May 22 2008 11:26:28 -07:00
cbr000rp1-sipsa.02.01.00.122-33.XNA.pkg
57603 -rw- 6256 May 22 2008 11:26:28 -07:00 packages.conf
13 -rw- 45977 Apr 9 2008 16:48:46 -07:00 target_support_output.tgz.tgz

```

```
928862208 bytes total (286662656 bytes free)
```

```

Router(config)# no boot system
Router(config)# config-register 0x2102
Router(config)# boot system flash bootflash:packages.conf
Router(config)# exit
Router# copy run start
Router# reload

```

## Copying a Set of Individual SubPackage Files, and Booting Using a Provisioning File

To copy a set of individual subpackage files and to boot using a provisioning file, perform the following steps:



**Note** Although this upgrade method works, it is less efficient than other methods of upgrading the router's software.

**Step 1** Copy each individual subpackage and the provisioning file into the bootflash: directory using the **copy** command. Note that this method of running the router will only work if all the individual subpackages for a release and a provisioning file are downloaded onto the router and stored in the bootflash: directory. No other file directories should be used for booting the router using individual subpackages.

The files can also be moved on the router physically using a USB Flash drive.

**Step 2** Configure the router to boot using the provisioning file.

The sequence below provides an example that describes how to boot the router using the provisioning file named `packages.conf` that was stored with the other subpackages in the bootflash: file system. The router runs using individual subpackages once the reload is complete.

```
Router(config)# no boot system
Router(config)# config-register 0x2102
Router(config)# boot system flash bootflash:packages.conf
Router(config)# exit
*May 11 01:31:04.815: %SYS-5-CONFIG_I: Configured from console by con
Router# write memory Building configuration... [OK]
Router# reload
```

## Installing an Optional SubPackage

To run the router using an optional subpackage, perform the following steps for each Supervisor in the chassis:

- Step 1** Verify that the Supervisor is running in individual subpackage mode and was booted from a provisioning file.
- Step 2** Verify that the version of the optional subpackage that you want to install is the same version as the software running on the active Supervisor.
- Step 3** Download the optional subpackage that you want to install. Optional subpackages must be downloaded independently from consolidated packages for the Cisco cBR Series Routers.
- Step 4** On each Supervisor, copy the optional subpackage to the directory where any other individual subpackages and the provisioning file is located.
- Step 5** Run the **request platform software package install rp 0 file** command, as shown in the following example.

Note Do not use the optional slot or bay keywords for the initial installation.

```
Router# request platform software package install rp 0 file
bootflash: cbrsup-universal*.bin
--- Starting local lock acquisition on R0 --- Finished local lock acquisition on R0

--- Starting file path checking --- Finished file path checking

--- Starting image file verification --- Checking image file names Verifying image file locations
Locating image files and validating name syntax
Found cbrsup-universal*.bin
Inspecting image file types Processing image file constraints Creating candidate provisioning file

WARNING: No package of type sipspawmak9 is installed.
WARNING: Package will be installed for all SIP slots and bays. Finished image file verification
--- Starting candidate package set construction --- Verifying existing software set Processing
```

```

candidate provisioning file Constructing working set for candidate package set Constructing working
set for running package set Checking command output Constructing merge of running and candidate
packages Checking if resulting candidate package set would be complete Finished candidate package
set construction

--- Starting compatibility testing ---
Determining whether candidate package set is compatible

WARNING:
WARNING: Candidate software combination not found in compatibility database
WARNING:

Determining whether installation is valid

WARNING:
WARNING: Candidate software combination not found in compatibility database
WARNING:

Software sets are identified as compatible Checking IPC compatibility with running software Checking
candidate package set infrastructure compatibility Checking infrastructure compatibility with running
software Checking package specific compatibility Finished compatibility testing

--- Starting impact testing --- Checking operational impact of change Finished impact testing

--- Starting list of software package changes --- No old package files removed New files list:
Added cbrsup-universal*.bin Finished list of software package changes

--- Starting commit of software changes --- Updating provisioning rollback files Creating pending
provisioning file Committing provisioning file Finished commit of software changes

--- Starting analysis of software changes --- Finished analysis of software changes

--- Starting update running software --- Blocking peer synchronization of operating information
Creating the command set placeholder directory
Finding latest command set
Finding latest command shortlist lookup file Finding latest command shortlist file Assembling CLI
output libraries
Assembling CLI input libraries
Applying interim IPC and database definitions
Replacing running software Replacing CLI software Restarting software
Restarting software: target frus filtered out ... skipped
Applying final IPC and database definitions Generating software version information Notifying running
software of updates
Unblocking peer synchronization of operating information Unmounting old packages
Cleaning temporary installation files
Finished update running software

SUCCESS: Finished installing software.

```

## Upgrading Individual SubPackages

### Patch Installation

Individual subpackages can be upgraded in subpackage mode. Patch releases consist of one or more subpackages. After a patch has been installed, a message is displayed indicating whether the entire chassis or only the line cards must be rebooted for the updates to take effect.



## Installing a Patch that Affects Both Line Card and Supervisor Card

---

- Step 1** The Cisco cBR router must be in subpackage mode.
  - Step 2** Copy the patch file to the same location as the active subpackages on both the active and standby supervisor cards.
  - Step 3** Install the patch using the **request platform software package install rp slot file patch file** command on the standby card.
  - Step 4** Install the patch using the **request platform software package install rp slot file patch file** command on the active card.
  - Step 5** Reload the chassis.
- 

## Installing a Patch that Affects Only Line Cards

---

- Step 1** The Cisco cBR router must be in subpackage mode.
  - Step 2** Copy the patch file to the same location as the active subpackages on both the active and standby supervisor cards.
  - Step 3** Install the patch using the **request platform software package install rp slot file patch file** command on the standby card.
  - Step 4** Install the patch using the **request platform software package install rp slot file patch file** command on the active card.
  - Step 5** Reload the line cards.
- 

## Installing a Patch that Affects Only Supervisor Cards

---

- Step 1** The Cisco cBR router must be in subpackage mode.
  - Step 2** Copy the patch file to the same location as the active subpackages on both the active and standby supervisor cards.
  - Step 3** Install the patch using the **request platform software package install rp slot file patch file** command on the standby card.
  - Step 4** Switch over to the standby card. This will make it the active card.
  - Step 5** Install the patch using the **request platform software package install rp slot file patch file** command on the standby card.
- 

## Upgrading a Line Card SubPackage

Use the **request platform software package install node file filename** command to upgrade a line card subpackage.

```
Router# request platform software package install node file  
bootflash:/subpkg/cbr_patch.5.0.tar
```

```
NOTE: Currently node has booted from a provisioning file  
NOTE: Going to start a dual rp sub-packages node ISSU install
```

```
--- Starting initial file path checking ---
```

```

Copying bootflash:/subpkg/cbr_patch.5.0.tar to stby-bootflash:/subpkg/cbr_patch.5.0.tar
Finished initial file path checking

--- Starting config-register verification ---
Finished config-register verification

--- Starting image file expansion ---
Expanding image file: bootflash:/subpkg/cbr_patch.5.0.tar
Image file expanded and copied
Expanding image file: stby-bootflash:/subpkg/cbr_patch.5.0.tar
Image file expanded and copied
Finished image file expansion

STAGE 1: Installing software on standby RP
=====
--- Starting local lock acquisition on R0 ---
Finished local lock acquisition on R0

--- Starting installation state synchronization ---
Finished installation state synchronization

--- Starting local lock acquisition on R1 ---
Finished local lock acquisition on R1

--- Starting file path checking ---
Finished file path checking

--- Starting image file verification ---
Checking image file names
Locating image files and validating name syntax
  Found cbrsup-clcdocsis.2015-02-20_01.02.SSA.pkg
Verifying image file locations
Inspecting image file types
Processing image file constraints
Creating candidate provisioning file
Finished image file verification

--- Starting candidate package set construction ---
Verifying existing software set
Processing candidate provisioning file
Constructing working set for candidate package set
Constructing working set for running package set
Checking command output
Constructing merge of running and candidate packages
Checking if resulting candidate package set would be complete
Finished candidate package set construction

--- Starting ISSU compatibility verification ---
Verifying image type compatibility
Checking IPC compatibility with running software
Checking candidate package set infrastructure compatibility
Checking infrastructure compatibility with running software
Checking package specific compatibility
Finished ISSU compatibility verification

--- Starting list of software package changes ---
Old files list:
  Removed cbrsup-clcdocsis.BLD_V155_2_S_XE315_THROTTLE_LATEST_20150217_110041-st
  d.SSA.pkg
New files list:
  Added cbrsup-clcdocsis.2015-02-20_01.02.SSA.pkg
Finished list of software package changes

```

```
--- Starting commit of software changes ---
Updating provisioning rollback files
Creating pending provisioning file
Committing provisioning file
Finished commit of software changes

--- Starting analysis of software changes ---
Finished analysis of software changes

--- Starting update running software ---
Blocking peer synchronization of operating information
Creating the command set placeholder directory
  Finding latest command set
  Finding latest command shortlist lookup file
  Finding latest command shortlist file
  Assembling CLI output libraries
  Assembling CLI input libraries
  Assembling Dynamic configuration files
  Applying interim IPC and database definitions
  Replacing running software
  Replacing CLI software
  Restarting software
  Restarting software: target frus filtered out ... skipped
  Applying final IPC and database definitions
  Generating software version information
  Notifying running software of updates
  Unblocking peer synchronization of operating information
Unmounting old packages
Cleaning temporary installation files
  Finished update running software

SUCCESS: Finished installing software.

STAGE 2: Installing software on active RP
=====
--- Starting local lock acquisition on R0 ---
Finished local lock acquisition on R0

--- Starting installation state synchronization ---
Finished installation state synchronization

--- Starting file path checking ---
Finished file path checking

--- Starting image file verification ---
Checking image file names
Locating image files and validating name syntax
  Found cbrsup-clcdocsis.2015-02-20_01.02.SSA.pkg
Verifying image file locations
Inspecting image file types
Processing image file constraints
Creating candidate provisioning file
Finished image file verification

--- Starting candidate package set construction ---
Verifying existing software set
Processing candidate provisioning file
Constructing working set for candidate package set
Constructing working set for running package set
Checking command output
Constructing merge of running and candidate packages
Checking if resulting candidate package set would be complete
Finished candidate package set construction
```

```

--- Starting ISSU compatibility verification ---
Verifying image type compatibility
Checking IPC compatibility with running software
Checking candidate package set infrastructure compatibility
Checking infrastructure compatibility with running software
Checking package specific compatibility
Finished ISSU compatibility verification

--- Starting impact testing ---
Checking operational impact of change
Finished impact testing

--- Starting list of software package changes ---
Old files list:
  Removed cbrsup-clcdocsis.BLD_V155_2_S_XE315_THROTTLE_LATEST_20150217_110041-st
d.SSA.pkg
New files list:
  Added cbrsup-clcdocsis.2015-02-20_01.02.SSA.pkg
Finished list of software package changes

--- Starting commit of software changes ---
Updating provisioning rollback files
Creating pending provisioning file
Committing provisioning file
Finished commit of software changes

--- Starting analysis of software changes ---
Finished analysis of software changes

--- Starting update running software ---
Blocking peer synchronization of operating information
Creating the command set placeholder directory
  Finding latest command set
  Finding latest command shortlist lookup file
  Finding latest command shortlist file
  Assembling CLI output libraries
  Assembling CLI input libraries
  Assembling Dynamic configuration files
  Applying interim IPC and database definitions
  Replacing running software
  Replacing CLI software
  Restarting software
  Restarting software: target frus filtered out ... skipped
  Applying final IPC and database definitions
  Generating software version information
  Notifying running software of updates
  Unblocking peer synchronization of operating information
Unmounting old packages
Cleaning temporary installation files
  Finished update running software

SUCCESS: Finished installing software.
Found clc package
Found clc package
Found clcdocsis package
SUCCESS: Reload Cable Linecard at slot 1
SUCCESS: Reload Cable Linecard at slot 2
SUCCESS: node ISSU finished successfully.
Invoking cleanup routine

```

Use the **request platform software package install node file *filename* noreload linecard** command to upgrade a line card subpackage.

```
Router#request platform software package install node file bootflash:/subpkg/cbr_patch.5.0.tar
noreload linecard
NOTE: Currently node has booted from a provisioning file
NOTE: Going to start a dual rp sub-packages node ISSU install

--- Starting initial file path checking ---
Copying bootflash:/subpkg/cbr_patch.5.0.tar to stby-bootflash:/subpkg/cbr_patch.
5.0.tar
Finished initial file path checking

--- Starting config-register verification ---
Finished config-register verification

--- Starting Checking noreload options ---
Finished Checking noreload options

--- Starting image file expansion ---
Expanding image file: bootflash:/subpkg/cbr_patch.5.0.tar
Image file expanded and copied
Expanding image file: stby-bootflash:/subpkg/cbr_patch.5.0.tar
Image file expanded and copied
Finished image file expansion

Found clc package

STAGE 1: Installing software on standby RP
=====
--- Starting local lock acquisition on R0 ---
Finished local lock acquisition on R0

--- Starting installation state synchronization ---
Finished installation state synchronization

--- Starting local lock acquisition on R1 ---
Finished local lock acquisition on R1

--- Starting file path checking ---
Finished file path checking

--- Starting image file verification ---
Checking image file names
Locating image files and validating name syntax
  Found cbrsup-clcdocsis.2015-03-01_01.40.SSA.pkg
Verifying image file locations
Inspecting image file types
Processing image file constraints
Creating candidate provisioning file
Finished image file verification

--- Starting candidate package set construction ---
Verifying existing software set
Processing candidate provisioning file
Constructing working set for candidate package set
Constructing working set for running package set
Checking command output
Constructing merge of running and candidate packages
Checking if resulting candidate package set would be complete
Finished candidate package set construction

--- Starting ISSU compatibility verification ---
Verifying image type compatibility
Checking IPC compatibility with running software
Checking candidate package set infrastructure compatibility
```

```

Checking infrastructure compatibility with running software
Checking package specific compatibility
Finished ISSU compatibility verification

--- Starting list of software package changes ---
Old files list:
  Removed cbrsup-clcdocsis.2015-03-01_03.43.SSA.pkg
New files list:
  Added cbrsup-clcdocsis.2015-03-01_01.40.SSA.pkg
Finished list of software package changes

--- Starting commit of software changes ---
Updating provisioning rollback files
Creating pending provisioning file
Committing provisioning file
Finished commit of software changes

--- Starting analysis of software changes ---
Finished analysis of software changes

--- Starting update running software ---
Blocking peer synchronization of operating information
Creating the command set placeholder directory
  Finding latest command set
  Finding latest command shortlist lookup file
  Finding latest command shortlist file
  Assembling CLI output libraries
  Assembling CLI input libraries
  Assembling Dynamic configuration files
  Applying interim IPC and database definitions
  Replacing running software
  Replacing CLI software
  Restarting software
  Restarting software: target frus filtered out ... skipped
  Applying final IPC and database definitions
  Generating software version information
  Notifying running software of updates
  Unblocking peer synchronization of operating information
Unmounting old packages
Cleaning temporary installation files
  Finished update running software

SUCCESS: Finished installing software.

STAGE 2: Installing software on active RP
=====
--- Starting local lock acquisition on R0 ---
Finished local lock acquisition on R0

--- Starting installation state synchronization ---
Finished installation state synchronization

--- Starting file path checking ---
Finished file path checking

--- Starting image file verification ---
Checking image file names
Locating image files and validating name syntax
  Found cbrsup-clcdocsis.2015-03-01_01.40.SSA.pkg
Verifying image file locations
Inspecting image file types
Processing image file constraints
Creating candidate provisioning file
Finished image file verification

```

```
--- Starting candidate package set construction ---
Verifying existing software set
Processing candidate provisioning file
Constructing working set for candidate package set
Constructing working set for running package set
Checking command output
Constructing merge of running and candidate packages
Checking if resulting candidate package set would be complete
Finished candidate package set construction

--- Starting ISSU compatibility verification ---
Verifying image type compatibility
Checking IPC compatibility with running software
Checking candidate package set infrastructure compatibility
Checking infrastructure compatibility with running software
Checking package specific compatibility
Finished ISSU compatibility verification

--- Starting impact testing ---
Checking operational impact of change
Finished impact testing

--- Starting list of software package changes ---
Old files list:
  Removed cbrsup-clcdocsis.2015-03-01_03.43.SSA.pkg
New files list:
  Added cbrsup-clcdocsis.2015-03-01_01.40.SSA.pkg
Finished list of software package changes

--- Starting commit of software changes ---
Updating provisioning rollback files
Creating pending provisioning file
Committing provisioning file
Finished commit of software changes

--- Starting analysis of software changes ---
Finished analysis of software changes

--- Starting update running software ---
Blocking peer synchronization of operating information
Creating the command set placeholder directory
  Finding latest command set
  Finding latest command shortlist lookup file
  Finding latest command shortlist file
  Assembling CLI output libraries
  Assembling CLI input libraries
  Assembling Dynamic configuration files
  Applying interim IPC and database definitions

Replacing running software
Replacing CLI software
Restarting software
Restarting software: target frus filtered out ... skipped
Applying final IPC and database definitions
Generating software version information
Notifying running software of updates
Unblocking peer synchronization of operating information
Unmounting old packages
Cleaning temporary installation files
  Finished update running software

SUCCESS: Finished installing software.
```

```
Found clc package
SUCCESS: node ISSU finished successfully.
Invoking cleanup routine
```

Use the **show platform software patch *n* info** command to verify completion of this upgrade.

```
Router#show platform software patch 1 info
cbrsup-clciosdb: 3.15 (0.0)
cbrsup-clc-firmware: 3.15 (0.0)
cbrsup-clcvideo: 3.15 (0.0)
cbrsup-clcios: 3.15 (0.0)
cbrsup-clccontrol: 3.15 (0.0)
cbrsup-clcdocsis: 3.15 (1.0)
cbrsup-clcmipsbase: 3.15 (0.0)
```

```
Router#show platform software patch 2 info
cbrsup-clciosdb: 3.15 (0.0)
cbrsup-clc-firmware: 3.15 (0.0)
cbrsup-clcvideo: 3.15 (0.0)
cbrsup-clcios: 3.15 (0.0)
cbrsup-clccontrol: 3.15 (0.0)
cbrsup-clcdocsis: 3.15 (1.0)
cbrsup-clcmipsbase: 3.15 (0.0)
```

Use the **show platform software ios *slot-number* restart info** command to verify completion of this upgrade. This example shows the output of this **show** command for the RF line card slot number 2.

```
Router#show platform software ios 2 restart info
IOSD process restart info:
  Process restartable: Yes
  IOSD restart state : NOT_RESTARTED_YET
  Total Modem Count  : 251
  Active Modem Count : 251
```

```
Router#
```



## Additional References

### Technical Assistance

Description	Link
<p>The Cisco Support website provides extensive online resources, including documentation and tools for troubleshooting and resolving technical issues with Cisco products and technologies.</p> <p>To receive security and technical information about your products, you can subscribe to various services, such as the Product Alert Tool (accessed from Field Notices), the Cisco Technical Services Newsletter, and Really Simple Syndication (RSS) Feeds.</p> <p>Access to most tools on the Cisco Support website requires a Cisco.com user ID and password.</p>	<a href="http://www.cisco.com/support">http://www.cisco.com/support</a>

## Feature Information for Consolidated Packages and SubPackages Management

Use Cisco Feature Navigator to find information about the platform support and software image support. Cisco Feature Navigator enables you to determine which software images support a specific software release, feature set, or platform. To access Cisco Feature Navigator, go to the <https://cfmg.cisco.com/> link. An account on the Cisco.com page is not required.



**Note** The following table lists the software release in which a given feature is introduced. Unless noted otherwise, subsequent releases of that software release train also support that feature.

**Table 14: Feature Information for Consolidated Packages and SubPackages Management**

Feature Name	Releases	Feature Information
Consolidated Packages and SubPackages Management	Cisco IOS XE Fuji 16.7.1	This feature was integrated on the Cisco cBR Series Converged Broadband Routers.





## CHAPTER 6

# Support for 2x100G DPIC

---

This document provides details of the Cisco cBR support for the Cisco cBR-8 2x100G DPIC and how to configure it on Cisco cBR Series Routers.

Your software release may not support all the features that are documented in this module. For the latest feature information and caveats, see the release notes for your platform and software release. The Feature Information Table at the end of this document provides information about the documented features and lists the releases in which each feature is supported.

Use Cisco Feature Navigator to find information about platform support and Cisco software image support. To access Cisco Feature Navigator, go to <http://tools.cisco.com/ITDIT/CFN/>. An account on <http://www.cisco.com/> is not required.

- [Hardware Compatibility Matrix for the Cisco cBR Series Routers, on page 119](#)
- [Information About Cisco cBR 2x100G DPIC, on page 121](#)
- [How to Configure 2x100G DPIC, on page 123](#)
- [Feature Information for 2x100G DPIC Support, on page 132](#)

## Hardware Compatibility Matrix for the Cisco cBR Series Routers



---

**Note** The hardware components that are introduced in a given Cisco IOS-XE Release are supported in all subsequent releases unless otherwise specified.

---

Table 15: Hardware Compatibility Matrix for the Cisco cBR Series Routers

Cisco CMTS Platform	Processor Engine	Interface Cards
Cisco cBR-8 Converged Broadband Router	<p><b>Cisco IOS-XE Release 16.5.1 and Later Releases</b></p> <p>Cisco cBR-8 Supervisor:</p> <ul style="list-style-type: none"> <li>• PID—CBR-SUP-250G</li> <li>• PID—CBR-CCAP-SUP-160G</li> </ul>	<p><b>Cisco IOS-XE Release 16.5.1 and Later Releases</b></p> <p>Cisco cBR-8 CCAP Line Cards:</p> <ul style="list-style-type: none"> <li>• PID—CBR-LC-8D30-16U30</li> <li>• PID—CBR-LC-8D31-16U30</li> <li>• PID—CBR-RF-PIC</li> <li>• PID—CBR-RF-PROT-PIC</li> <li>• PID—CBR-CCAP-LC-40G</li> <li>• PID—CBR-CCAP-LC-40G-R</li> <li>• PID—CBR-CCAP-LC-G2-R</li> <li>• PID—CBR-SUP-8X10G-PIC</li> <li>• PID—CBR-2X100G-PIC</li> </ul> <p>Digital PICs:</p> <ul style="list-style-type: none"> <li>• PID—CBR-DPIC-8X10G</li> <li>• PID—CBR-DPIC-2X100G</li> </ul> <p>Cisco cBR-8 Downstream PHY Module:</p> <ul style="list-style-type: none"> <li>• PID—CBR-D31-DS-MOD</li> </ul> <p>Cisco cBR-8 Upstream PHY Modules:</p> <ul style="list-style-type: none"> <li>• PID—CBR-D31-US-MOD</li> </ul>



**Note** Do not use DPICs (8X10G and 2x100G) to forward IP traffic, as it may cause buffer exhaustion, leading to line card reload.

The only allowed traffic on a DPIC interface is DEPI, UEPI, and GCP traffic from the Cisco cBR-8 router to Remote PHY devices. Other traffic such as DHCP, SSH, and UTSC should flow via another router, since DPICs cannot be used for normal routing.

## Information About Cisco cBR 2x100G DPIC

The Cisco cBR-8 2x100G Digital Physical Interface Card (DPIC) fo Remote PHY provides two QSFP ports. The 2x100G DPIC works only with the CBR-CCAP-LC-G2-R line card to transmit DEPI, UEPI, and GCP traffic from the Cisco cBR-8 router to Remote PHY devices.

The 2x100G DPIC has two groups of LEDs mapped to each QSFP port. If you have configured 10GE mode, QSFP0 maps to LEDs 0,2,4, and 6, while QSFP1 maps to LEDs 1,3,5, and 7. If you have configured 100GE mode, QSFP0 maps to LED 0 and QSFP1 maps to LED 1.

This DPIC supports Onboard Failure Logging (OBFL), environment monitoring, and FPD. However, the 2x100G DPIC does not support 8x10G DPIC or RF-PIC card protection.

The product ID (PID) of 2x100G DPIC is CBR-DPIC-2X100G.

## Limitations on Downstream Bandwidth

For 2x100G DPIC, each XFI group supports a maximum of 10Gbps bandwidth—9Gbps for data traffic and 1Gbps for control packets. An error message similar to the following is logged in the syslog, when the theoretical maximum bandwidth for all video channels in a group exceeds 9Gbps.

```
%IOSXE-3-PLATFORM: CLC8: cdman: Video channel oversubscribed!! Downstream controller 8/0/0~7
bandwidth ratio is 100.1040%.
```

For CBR-CCAP-LC-G2-R cards that support 40G DPIC, eight 10GE interfaces are divided into four XFI groups.

For each 10G interface, theoretical bandwidth of all downstream channels configured under **Te** `<slot>/<subslot>/0` and **Te** `<slot>/<subslot>/1` must not exceed 9Gbps.

10GE Port	XFI Group
0	0
1	
2	1
3	
4	2
5	
6	3
7	

For CBR-CCAP-LC-G2-R cards supporting 40G DPIC 2x100G mode, only one 100GE interface is active. 32 downstream controllers are divided into four XFI groups.

Since there is only one 100G interface, for each downstream controller, the theoretical bandwidth of all downstream channels configured under **cable downstream controller** `<slot>/<subslot>/0 | <slot>/<subslot>/7` must not exceed 9Gbps.

Controller	XFI Group
0-7	0
8-15	1
16-23	2
24-31	3

This table shows the theoretical maximum number of SCQAM downstream channels in each XFI group for different annex and QAM modulation.

Annex	QAM Modulation	Theoretical Bandwidth (Mbps)	Maximum Number of Downstream Channels
Annex A	64	38.4	234
Annex A	256	51.3	175
Annex B	64	26.9	334
Annex B	256	38.8	231

## Support for Link Redundancy

The 2x100G DPIC supports only active-standby link redundancy mode, where if one interface is active, the other remains on standby. The 2x100G DPIC does not support active-active link redundancy mode. But, if the 2x100G DPIC is configured to work in the 8x10G DPIC mode, then the 2x100G DPIC supports active-standby and active-active link redundancy modes. Run the **sh ip int b | in te slot/subslot** command to view the details.

```
Router#sh ip int b | in Te9/1/
Te9/1/0    90.0.0.1    YES    NVRAM    up        up
Te9/1/1    91.0.0.1    YES    NVRAM    administratively down  down
Te9/1/2    92.0.0.1    YES    VRAM     up        up
Te9/1/3    93.0.0.1    YES    NVRAM    administratively down  down
Te9/1/4    94.0.0.1    YES    NVRAM    up        up
Te9/1/5    95.0.0.1    YES    NVRAM    administratively down  down
Te9/1/6    96.0.0.1    YES    NVRAM    up        up
Te9/1/7    88.0.97.1   YES    NVRAM    administratively down  down
```

If link redundancy is not enabled, then you cannot use port 1.

The 2x100G DPIC supports both standby-hot and standby-cold redundancy modes.

The 100GE <slot>/1/9 always remains administratively down irrespective of whether QSFP is installed or not. Run the **sh ip int b | in Hu** command to view the 100GE interface details.

```
Router#sh ip int b | in Hu
HundredGigE0/1/8  209.165.200.225  YES    NVRAM    up        up
HundredGigE0/1/9  unassigned        YES    unset    administratively down  down
```

# How to Configure 2x100G DPIC

## View 2x100G DPIC Details

To view the 2x100G DPIC details, run the **show platform**

.This is a sample configuration.

```
Chassis type: CBR-8-CCAP-CHASS
```

Slot	Type	State	Insert time (ago)
0	CBR-CCAP-LC-G2-R	ok	01:06:50
0/1	CBR-DPIC-2X100G	ok	01:03:36
1/1	CBR-RF-PROT-PIC	ok	01:03:35
2/1	CBR-DPIC-8X10G	ok	01:03:33
3	CBR-CCAP-LC-G2-R	ok	01:06:50
3/1	CBR-DPIC-2X100G	ok	01:03:29
...			

## Configure 2x100G DPIC Mode

The 2x100G DPIC supports two modes—10G and 100G modes. To create a DPIC-100G card with 2x100GE interface mode, perform these steps.

```
Router# configure terminal
Router(config)# card <slot>/0 CBR-CCAP-LC-G2-R r-phy DPIC-G2-100GE
```

To create a DPIC-100G card with 8x10GE interface mode, perform these steps.

```
Router# configure terminal
Router(config)# card 2/0 CBR-CCAP-LC-G2-R r-phy DPIC-G2-10GE
```

## Verify 2x100G DPIC Mode

To verify the 2x100G DPIC mode configuration, run the **sh run | i card** command.

```
Router# sh run | i card
card 0/0 CBR-CCAP-LC-G2-R r-phy DPIC-G2-100GE
card 1/0 CBR-CCAP-LC-G2-R r-phy DPIC-G2-100GE
card 2/0 CBR-CCAP-LC-G2-R r-phy DPIC-G2-100GE
card 3/0 CBR-CCAP-LC-G2-R r-phy DPIC-G2-100GE
...
card 6/0 CBR-CCAP-LC-G2-R r-phy DPIC-G2-100GE
card 7/0 CBR-CCAP-LC-G2-R r-phy DPIC-G2-100GE
card 8/0 CBR-CCAP-LC-G2-R r-phy DPIC-G2-100GE
card 9/0 CBR-CCAP-LC-G2-R r-phy DPIC-G2-10GE
```

## Verify 2x100G Ethernet Interface Status

To verify the 2x100G ethernet interface status, run the **show interfaces HundredGigE <slot>/1/<8-9>**

.This is a sample configuration.

```
Router# show interface HundredGigE 3/1/8
```

```

HundredGigE3/1/8 is up, line protocol is up
Hardware is CBR-DPIC-2X100G, address is 1ce4.3df59.6e12 (bia 1c6.8df5.1c13)
Internet address is 209.165.200.225/24
MTU 2350 bytes, BW 100000000 Kbit/sec, DLY 10 usec,
    reliability 255/255, txload 1/255, rxload 1/255
Encapsulation ARPA, loopback not set
. . .
Full Duplex, 100000Mbps, link type is force-up, media type is QSFP_100GE_SR
. . .
30 second input rate 10000 bits/sec, 5 packets/sec
30 second output rate 0 bits/sec, 0 packets/sec
26487 packets input, 6442316 bytes, 0 no buffer
Received 3913 broadcasts (0 IP multicasts)
0 runs, 0 giants, 0 throttles
0 input errors, 0 CRC, 0 frame, 0 overrun, 0 ignored
0 watchdog, 22571 multicast, 0 pause input
965 packets output, 152548 bytes, 0 underruns
0 output errors, 0 collisions, 1 interface resets
1375 unknown protocol drops
0 babbles, 0 late collision, 0 deferred
0 lost carrier, 0 no carrier, 0 pause output
0 output buffer failures, 0 output buffers swapped out

```

## Switch Between 8x10G and 2x100G Modes

To switch between 8x10G and 2x100G modes, perform these steps.

1. Verify the current mode by running **show run**.

```

Router# configure terminal
Router#sh run | in card 9/0
card 9/0 CBR-CCAP-LC-G2-R r-phy DPIC-G2-10GE

```

2. Switch modes by running these commands.

```

Router#config t
Enter configuration commands, one per line. End with CNTL/Z.
Router(config)#hw-module slot 9 shutdown
Router(config)#hw-module subslot 9/1 shutdown
Router(config)#no card 9/0 CBR-CCAP-LC-G2-R r-phy DPIC-G2-10GE
Router(config)#card 9/0 CBR-CCAP-LC-G2-R r-phy DPIC-G2-100GE
Router(config)#no hw-module subslot 9/1 shutdown
Router(config)#no hw-module slot 9 shutdown
Router(config)#end

```



---

**Caution** When you run the **no card** command, the console becomes nonresponsive for more than 20 seconds. While the console is nonresponsive, do not run any commands in other sessions to the Cisco cBR.

---

3. Verify the mode again by running **show run**.

```

Router#sh run | in card 9/0
card 9/0 CBR-CCAP-LC-G2-R r-phy DPIC-G2-100GE

```

4. Run the **show platform** command to verify the status of the DPIC.

```

Router# show platform

Slot      Type                               State      Insert time (ago)
-----

```



```

0          CBR-CCAP-LC-G2-R    ok          01:06:50
0/1        CBR-DPIC-2X100G    ok          01:03:36

```

## Configure RPD

To configure RPD using the 100G interface, use the **cable rpd node** command. This is an example of onfiguring RPD.

```

cable rpd node_313
  identifier badb.ad13.419a
  type shelf
  rpd-ds 0 max-carrier 158
  rpd-ds 0 base-power 32
  rpd-ds 1 max-carrier 158
  rpd-ds 1 base-power 34
  core-interface Hu0/1/8
  principal
  rpd-ds 0 downstream-cable 0/0/19 profile 32
  rpd-us 0 upstream-cable 0/0/38 profile 37
  rpd-us 1 upstream-cable 0/0/39 profile 38
  r-dti 6
  rpd-event profile 0
  rpd-55d1-us-event profile 0

```

## Configure RPD Location Attributes Through CLI

**Table 16: Feature History**

Feature	Release	Description
New RPD location attributes to configure RPD's description, latitude, and longitude.	Cisco IOS XE Dublin 17.12.1w	You can now configure RPD's description, latitude, and longitude that helps you to track the location attributes of an RPD seamlessly.

You can now configure attributes such as description, latitude, and longitude for an RPD into the cBR8 router using a CLI command. This helps you to track the location attributes of an RPD seamlessly. The RPD location attributes are saved into the database and then sent to RPD.



**Note** When you receive the location configuration attributes through SNMP, the configured location attributes are updated, received and saved to the database.

- **Device Location Description (description)**—Allows the RPD to inform the CCAP core about its location. Use the location description command to configure the RPD location description details. The valid range is 1-255. When you configure the description attribute, the RPD stores its value in its nonvolatile configuration. The valid range is 1-255.
- **Geo Location Latitude (latitude)**—Allows the RPD to inform the CCAP core about the latitude portion of its geographic location. Use the location latitude command to configure the RPD location latitude details. The RPD uses 6-digit notation in the format degree, minute, seconds, ±DDMMSS.S. When you configure the latitude attribute, the RPD stores its value in its nonvolatile configuration.

For example: +123254.7.

- **Geo Location Longitude (longitude)**—Allows the RPD to inform the CCAP core about the longitude portion of its geographic location. Use the location longitude command to configure the RPD location longitude details. The RPD uses 7-digit notation in the format degree, minute, seconds, ±DDMMSS.S. When you configure the longitude attribute, the RPD stores its value in its nonvolatile configuration.

For example: +2340517.1.

When you get the location configuration attributes through SNMP, you must get the same CLI configured values from the database.

The SNMP set command and the CLI configuration is supported for configuring the RPD location values.

### Configuring RPD Location Attributes

To configure the RPD location attributes, execute the following commands:

```
router#cable rpd <rpd-name>
router#location { description | latitude | longitude }
```

the device location description for RPD indicates the maximum length which is 255 bytes, geo location latitude +000000.0 for RPD indicates the maximum length that is 9 bytes, and geo location longitude +0000000.0 for RPD indicates the maximum length that is 10 bytes.

The following is the sample output of the **cable rpd rpd-location** command:

```
router(conf)#cable rpd rpd-location-test
router(conf)#location desc rpd-loc
router(conf)#location latitude +123456.7
router(conf)#location longitude +1234567.8
```

The following is the sample output of the **show cable rpd location** command:

```
router#show cable rpd location
RPD ID                : f4db.e6cd.d838
Location Description  : RPD_dev3-details
Latitude              : +999999.7
Longitude             : +8888888.8

RPD ID                : f4db.e6cd.d8bc
Location Description  : RPD_dev2-details
Latitude              : +565656.1
Longitude             : +3245432.5

RPD ID                : f4db.e6cd.d8c8
Location Description  : RPD_dev1-details
Latitude              : +123456.7
Longitude             : +8978564.1
```

### Verifying the RPD Location Configuration Attributes

The following is the sample output of the **show running-config | i location** command:

```
router#show running-config | i location
location description CBR8
location latitude +908070.1
location longitude +1236098.5
```

### Verify the Values Sent to the RPD

To verify the values sent to the RPD, use the **show cable rpd gcp-transaction verbose** command as shown in the example below:

```
router#show cable rpd <MAC> <I/F> gcp-transaction verbose

router#show cable rpd gcp-transaction verbose | s TYPE_DEVICE
{ T = TYPE_DEVICEALIAS(8), L = 0, V = }
{ T = TYPE_DEVICELOCATION(24), L = 40, V = }
{ T = TYPE_DEVICE_LOCATION_DESCRIPTION(1), L = 12, V = CBR8 }
{ T = TYPE_GEO_LOCATION_LATITUDE(2), L = 9, V = +908070.1}
{ T = TYPE_GEO_LOCATION_LONGITUDE(3), L = 10, V = +1236098.5 }
{ T = TYPE_DEVICEALIAS(8), L = 0, V = }
{ T = TYPE_DEVICELOCATION(24), L = 40, V = }
{ T = TYPE_DEVICE_LOCATION_DESCRIPTION(1), L = 12, V = CBR8 }
{ T = TYPE_GEO_LOCATION_LATITUDE(2), L = 9, V = +908070.1}
{ T = TYPE_GEO_LOCATION_LONGITUDE(3), L = 10, V = +1236098.5 }
{ T = TYPE_DEVICEALIAS(8), L = 0, V = }
```

### snmp commands

The SNMP get and SNMP walk commands are used to retrieve the CLI configured values.

The following is an example of SNMP walk on the RPD location:

```
server > snmpwalk -v2c -c private 2.24.1.1 1.3.6.1.4.1.4491.2.1.31.1.1.6
SNMPv2-SMI::enterprises.4491.2.1.31.1.1.6.1.1.0.4.159.49.8.37 = ""
SNMPv2-SMI::enterprises.4491.2.1.31.1.1.6.1.2.0.4.159.49.8.37 = STRING: "RPD1"
SNMPv2-SMI::enterprises.4491.2.1.31.1.1.6.1.3.0.4.159.49.8.37 = STRING: "CBR8"
SNMPv2-SMI::enterprises.4491.2.1.31.1.1.6.1.4.0.4.159.49.8.37 = STRING: "+908070.1"
SNMPv2-SMI::enterprises.4491.2.1.31.1.1.6.1.5.0.4.159.49.8.37 = STRING: "+1236098.5"

router#scr f86b.d9ff.fd1e location
RPD ID                : f86b.d9ff.fd1e
Location Description  : CBR8
Latitude              : +908070.1
Longitude             : +1236098.5
```

The following example shows SNMP using the community private using SNMP version 2c:

For Location:

```
server > snmpget -v2c -c private 2.24.1.1
SNMPv2-SMI::enterprises.4491.2.1.31.1.1.6.1.3.0.4.159.49.8.37
SNMPv2-SMI::enterprises.4491.2.1.31.1.1.6.1.3.0.4.159.49.8.37 = STRING: "CBR8"
```

For Latitude

```
server > snmpget -v2c -c private 2.24.1.1
SNMPv2-SMI::enterprises.4491.2.1.31.1.1.6.1.4.0.4.159.49.8.37
SNMPv2-SMI::enterprises.4491.2.1.31.1.1.6.1.4.0.4.159.49.8.37 = STRING: "+908070.1"
```

For Longitude

```
server > snmpget -v2c -c private 2.24.1.1
SNMPv2-SMI::enterprises.4491.2.1.31.1.1.6.1.5.0.4.159.49.8.37
SNMPv2-SMI::enterprises.4491.2.1.31.1.1.6.1.5.0.4.159.49.8.37 = STRING: "+1236098.5"
```

```
server > snmpset -v2c -c private 2.32.1.1
SNMPv2-SMI::enterprises.4491.2.1.31.1.1.6.1.3.0.39.144.11.14.20 s "INDIA"
SNMPv2-SMI::enterprises.4491.2.1.31.1.1.6.1.3.0.39.144.11.14.20 = STRING: "INDIA"
```

The following is the sample output of the **do scr location**:

```
router#do scr location
RPD ID                : 0027.900b.0e14
Location Description  : Valid
```

```
Latitude           : +123456.7
Longitude          : +1234567.8
```

The following is the sample output of the `show cable rpd <mac> <i/f> gcp-transaction verbose` location:

```
router#show cable rpd <mac> <i/f> gcp-transaction verbose
router#scr
MAC Address      IP Address      I/F      State      Role HA  Auth Name
0027.900b.0e14  ---            Hu2/1/8  online     Pri  Act N/A  RPD_dev1
0027.900b.0e20  ---            Hu2/1/8  online     Pri  Act N/A  RPD_dev2
0027.900b.0e38  ---            Hu2/1/8  online     Pri  Act N/A  RPD_dev3
```

! = PTP clock out of phaselock occurred, ^ = Default password in use

```
router#conf t
Enter configuration commands, one per line.  End with CNTL/Z.
router#cable rpd RPD_dev1
router#location description ARMY
router#location latitude +123456.7
router#location longitude -9080786.1
router#do scr location
RPD ID           : 0027.900b.0e14
Location Description : ARMY
Latitude         : +123456.7
Longitude        : -9080786.1

RPD ID           : 0027.900b.0e20
Location Description : RPD_dev2-info
Latitude         : +123123.7
Longitude        : +2344321.8

RPD ID           : 0027.900b.0e38
Location Description : NA
Latitude         : +000000.0
Longitude        : +0000000.0
```

## Identifying RPD PTP Clock issues Through SNMP Polling

*Table 17: Feature History*

Feature Name	Release Information	Feature Description
RPD PTP MIB Update	Cisco IOS XE Dublin 17.12.1x	The following MIB table has been added to the SNMP Polling to identify PTP clock state issues: <ul style="list-style-type: none"> <li>docsRphyPtpRpdClockStatusTable</li> </ul>

In this release, if RPDs get stuck in `init(clock)` state for any reason, we can poll the converged broadband routers (cBR) for the RPD PTP MIB (`docsRphyPtpRpdClockStatusClockState/ docsRphyPtpRpdClockStatusComputedPhaseOffset`) and identify the RPDs having PTP issue after the generic control protocol (GCP) is up even before RPD is online.

Previously, a user needed to log into the cBR and check **show cable rpd** command to determine whether RPDs are stuck in init(clock)/ having any PTP issues.

## Support for 2x4 RPD

Table 18: Feature History

Feature Name	Release Information	Feature Description
Support for 2x4 RPD	Cisco IOS XE Dublin 17.12.1x	In this feature, RPD can handle up to 4 upstream ports on the cBR8 core side.

The Range of RPD upstream ports are extended from <0-3> and the commands affected by this are as follows:

To configure

```

rpd-us <0-3> description <decs>
rpd-us <0-3> base-power-rx-level-1_6Mhz <-20 - 40>
rpd-us <0-3> Upstream-Cable <x/0/y> profile <z>
rpd-us <0-3> Upstream-OOB-varpd <1-32> profile <x>
rpd-us <0-3> static-pseudowire <name>

```



**Note** There is no configuration limitation for MD (Mac Domain) and FN (Fiber Node) on cBR8.

## New TLVs RPD Reset Control Operation

Table 19: Feature History

Feature Name	Release Information	Feature Description
New TLVs RPD Reset Control Operation	Cisco IOS XE Dublin 17.12.1w	<p>You can now use the new ResetCtrl TLV option to reset the RPDs on the cBR router. The new TLV with the defined type, length, units, values control the RPD reset operations.</p> <p>Performs hardware reset using TLV40.1.1 on:</p> <ul style="list-style-type: none"> <li>• All RPDs</li> <li>• Specific RPD using MAC address</li> <li>• Specific RPD interface</li> <li>• Specific RPD slot</li> </ul>

The following table lists the new ResetCtrl defined type, length, units, values (TLVs) to control RPD reset.

Table 20: New TLVs RPD Reset Control Operation

TLV Type	Length	Units	Access	Value
40.1.1	1	–	R/W	<p>An enumerated value with the following defined values:</p> <ul style="list-style-type: none"> <li>• <code>softReset(1)</code>—Resets the software.</li> <li>• <code>hardReset(2)</code>—Performs a power-on reset or an equivalent reset.</li> <li>• <code>nvReset(3)</code>—Clears the non-volatile configuration and performs a hard reset.</li> <li>• <code>factoryReset(4)</code>—Restores the factory configuration and performs a hard reset.</li> </ul>

## Clearing the RPD Reset Control Operation

You can perform the reset control for all RPDs together, at the slot level, on the interface, using the IP Address for RPD, or for a specific RPD using the MAC address.

For each reset control operation, you can perform the following TLV 40.1.1 operations on the remote PHY device:

- Factory configuration reset
- Hardware reset
- Non-volatile configuration reset
- Software reset

Use the following clear commands to clear the RPD Reset Control configurations:

- `router#clear cable rpd all reset {factory | hard | non-volatile | soft}`
- `router#clear cable rpd slot no reset {factory | hard | non-volatile | soft}`
- `router#clear cable rpd interface reset {factory | hard | non-volatile | soft}`
- `router#clear cable rpd ip address reset {factory | hard | non-volatile | soft}`
- `router#clear cable rpd mac address reset {factory | hard | non-volatile | soft}`

To perform the reset control operation for all RPDs together, use the `clear cable rpd all reset` command as shown in the example below:

Example

```
router#clear cable rpd all reset {factory | hard | non volatile | soft}
```

To perform the reset control operation at the slot level, use the **clear cable rpd slot no reset** command as shown in the example below:

Example

```
router#clear cable rpd slot 6 reset {factory | hard | non volatile | soft}
```

To perform the reset control operation on the interface, use the **clear cable rpd interface reset** command as shown in the example below:

Example

```
router#clear cable rpd interface Te6/1/5 reset {factory | hard | non volatile | soft}
```

To perform the reset control operation for the RPD IP address, use the **clear cable rpd ip address reset** command as shown in the example below:

Example

```
router#clear cable rpd 30.85.65.150 reset {factory | hard | non volatile | soft}
```

To perform the reset control operation for a specific RPD using the MAC address, use the **clear cable rpd** command as shown in the example below:

Example

```
router#clear cable rpd 0018.48fe.e643 reset {factory | hard | non volatile | soft}
```

## Verifying the RPD Reset Control Operation

Use the following show command to verify the RPD Reset Control configuration:

```
router#show cable rpd
```

To verify the RPD ResetCtrl operation, use the **show cable rpd** command as shown in the example below:

Example

```
router#show cable rpd
Load for five secs: 8%/1%; one minute: 7%; five minutes: 7%
Time source is NTP, 13:12:23.636 CST Mon Aug 28 2023

MAC Address IP Address I/F State Role HA Auth Name
0018.48fe.e643 30.85.65.150 Te6/1/5 online Pri Act N/A vecima-rpd
1004.9fb1.1300 30.85.65.153 Te6/1/5 online Pri Act N/A ng13-shelf-node2

! = PTP clock out of phaselock occurred, ^ = Default password in use
router#
```

## Configure Link Redundancy

To enable link redundancy, run the **cable rphy link redundancy [hot | cold]** command.

To verify if link redundancy is enabled, run the **show redundancy digi-PIC** command.

```
Router#show redundancy digi-PIC
Load for five secs: 26%/5%; one minute: 49%; five minutes: 45%
Time source is NTP, *13:26:58.020 CST Mon Jul 1 2019
```

```

RPHY Link HA: Cold mode enabled
Core Interface  Port  Mode      Role      Status
-----
Hu 0/1/8        8    Primary   Active    Up
Hu 0/1/8        9    Secondary Standby    Ready
Hu 1/1/8        8    Primary   Active    Up
Hu 1/1/8        9    Secondary Standby    Ready

```

## Feature Information for 2x100G DPIC Support

Use Cisco Feature Navigator to find information about the platform support and software image support. Cisco Feature Navigator enables you to determine which software images support a specific software release, feature set, or platform. To access Cisco Feature Navigator, go to the <https://cfng.cisco.com/> link. An account on the Cisco.com page is not required.



**Note** The following table lists the software release in which a given feature is introduced. Unless noted otherwise, subsequent releases of that software release train also support that feature.

*Table 21: Feature Information for 2x100G DPIC Support*

Feature Name	Releases	Feature Information
Support for 2x100G DPIC	Cisco IOS XE Gibraltar 16.12.1	This feature was introduced in Cisco IOS XE Gibraltar 16.12.1 on Cisco cBR Series Converged Broadband Router.





## CHAPTER

# 7

## G.8275.2 Telecom Profile

---

This document provides information on the support for G.8275.2 telecom profile and how to configure Cisco cBR series routers to avail the support.

Your software release may not support all the features that are documented in this module. For the latest feature information and caveats, see the release notes for your platform and software release. The Feature Information Table at the end of this document provides information about the documented features and lists the releases in which each feature is supported.

Use Cisco Feature Navigator to find information about platform support and Cisco software image support. To access Cisco Feature Navigator, go to <http://tools.cisco.com/ITDIT/CFN/>. An account on <http://www.cisco.com/> is not required.

- [G.8275.2 Telecom Profile, on page 133](#)
- [Information About G.8275.2 Telecom Profile, on page 133](#)
- [How to Configure the G.8275.2 Profile, on page 136](#)
- [Configuration Examples, on page 137](#)
- [DPIC PTP Primary, on page 138](#)
- [Feature Information for G.8275.2 Profile, on page 144](#)

## G.8275.2 Telecom Profile

### Information About G.8275.2 Telecom Profile

Precision Time Protocol (PTP) is a protocol for distributing precise time and frequency over packet networks. PTP is defined in the IEEE Standard 1588. It defines an exchange of timed messages.

PTP allows for separate profiles to be defined in order to adapt PTP for use in different scenarios. A profile is a specific selection of PTP configuration options that are selected to meet the requirements of a particular application.

Effective Cisco IOS XE Fuji 16.8.1, Cisco cBR Converged Broadband routers support the ITU- T G.8275.2 telecom profile (PTP telecom profile for Phase/Time-of-day synchronization with partial timing support from the network).

The G.8275.2 is a PTP profile for use in telecom networks where phase or time-of-day synchronization is required. It differs from G.8275.1 in that it is not required that each device in the network participates in the PTP protocol. Also, G.8275.2 uses PTP over IPv4 and IPv6 in unicast mode.

## Why G.8275.2 Telecom Profile?

The G.8275.2 profile is based on the partial timing support from the network. Hence nodes using G.8275.2 are not required to be directly connected.

The G.8275.2 profile is used in mobile cellular systems that require accurate synchronization of time and phase. For example, the fourth generation (4G) of mobile telecommunications technology.

## PTP Clocks

Two types of ordinary clocks are used in this profile:

### Ordinary Clocks (OCs)

- **Telecom Grandmaster (T-GM)**—A telecom grandmaster provides timing for other devices in the network, and is usually connected to a primary reference time source, such as a GNSS receiver. It does not synchronize its local clock to other network elements. Considerations for a T-GM:
  - Only one PTP port can be configured as a primary port.
  - One T-GM primary port can have multiple subordinates associated with it.
  - The T-GM OC primary port is a fixed port; that is, it always acts as a primary clock and its role does not change by negotiating with its peer.
- **Partial-Support Telecom Time Subordinate Clocks (T-TSC-P and T-TSC-A)**—A subordinate clock synchronizes its local clock to another PTP clock (GM, T-GM or T-BC), and does not provide synchronization through PTP to any other device. Considerations for a T-TSC-P:
  - An ordinary clock with single subordinate port can be configured.
  - Only one peer clock address can be configured as clock source.



---

**Note**

- Ordinary clocks (OC) always have only one PTP port.
  - In G.8275.2 (02/2016), PTP transparent clocks are not permitted.
- 

## PTP Domain

A PTP domain is a logical grouping of clocks that communicate with each other using the PTP protocol.

A single computer network can have multiple PTP domains operating separately, for example, one set of clocks synchronized to one time scale and another set of clocks synchronized to another time scale. PTP can run over either Ethernet or IP, so a domain can correspond to a local area network or it can extend across a wide area network.

The allowed domain numbers of PTP domains within a G.8275.2 network are in the range of 44 and 63 (both inclusive). The default domain number is 44.

## PTP Messages and Transport

The following PTP transport parameters are defined:

- In Cisco IOS XE Fuji 16.8.1, PTP over IPv4 in unicast mode must be used.
- One-step clock mode must be used.
- The G.8275.2 profile supports unicast message negotiation.

## PTP Ports

A port can be configured to perform either fixed primary or subordinate role or can be configured to change its role dynamically. If no role is assigned to a port, it can dynamically assume a primary, passive, or subordinate role based on the BMCA.

In G.8275.2, PTP ports are not tied to any specific physical interfaces, but are tied to a loopback (virtual) interface. Traffic from a PTP port is routed through any physical interface based on the routing decision.

For a dynamic port, only one clock source can be configured.

## Alternate BPCA

The BPCA (Best Primary Clock Algorithm, which is also known as Best Master Clock Algorithm (BMCA [RFC 7273])) implementation in G.8275.2 is different from that in the default PTP profile. The G.8275.2 implementation specifies an alternate best primary clock algorithm (ABPCA), which is used by each device to select a clock to synchronize to, and to decide the port states of its local ports.

The following considerations apply to the G.8275.2 implementation of the BPCA:

- **PrimaryOnly**—A per port attribute, PrimaryOnly defines the state of the port. If this attribute is true, the port is never placed in the subordinate state.
- **Priority 1**—Priority 1 is always static in this profile and is set to 128. Priority 1 is not used in BPCA.
- **Priority 2**—Priority 2 is a configurable value and its range is from 0 to 255.
- **Local Priority**—Local priority is configured locally on clock ports to set the priority on nominated clocks. The default value is 128 and valid range is from 1 to 255.

## Benefits

With upcoming technologies like LTE-TDD, LTE-A CoMP, LTE MBSFN and Location-based services, eNodeBs (base station devices) are required to be accurately synchronized in phase and time. Having GNSS systems at each node is not only expensive, but also introduces vulnerabilities. The G.8275.2 profile meets the synchronization requirements of these new technologies.

## Restrictions for Using the G.8275.2 Profile

- In G.8275.2, PTP can be used in both hybrid mode and non-hybrid mode. In hybrid mode, PTP is used to provide phase and time-of-day throughout the network synchronization along with PHY layer frequency support (SyncE). In non hybrid mode, PTP is used without PHY layer frequency support (SyncE).

- A G.8275.2 PTP clock can have redundant clock sources configured (through multiple PTP ports). However, at any given time, a G.8275.2 PTP clock synchronizes to only one clock source, which is selected by BMCA.
- The G.8275.2 does not provide any recommendations for performance analysis and network limits for the clocks.

## How to Configure the G.8275.2 Profile

### Creating an Ordinary Subordinate (T-TSC-P)

Cisco cBR-8 supports PTP ordinary clock subordinate mode with G8275.2 profile. In this mode, PTP ports are either on the Supervisor PIC cards or on the 10GE Ethernet ports on the DPIC cards.

To create an ordinary subordinate, run the following steps:

```
ptp clock Ordinary domain 44
    clock-port slave-port slave profile G.8275.2
    transport ipv4 unicast interface lo 0 negotiation
    clock source 10.1.1.1
```

### Configuring Dual PTP Primary Clocks

Dual PTP primary clocks must connect to the same grandmaster. Both PTP primary clocks and the grandmaster must be set to Priority 2 configuration. You must set the minimum Priority 2 value for the grandmaster to keep the highest priority. The PTP primary clocks connected to the grandmaster must have a Priority 2 value.

The following example shows a grandmaster in the Dual PTP primary clocks configuration:

```
Router# show run | se ptp
license feature ptp
ptp clock ordinary domain 44
  priority2 2
  clock-port master-to-two903 master profile g8275.2
  sync interval -5
  sync one-step
  transport ipv4 unicast interface Lo1588 negotiation
```

### Configuring the G.8275.2 Profiles

To configure G.8275.2 Profiles, run the following steps:

```
Router# config terminal
Enter configuration commands, one per line. End with CNTL/Z.
Router(config)# ptp clock ordinary domain 55
Router(config-ptp-clk)#servo tracking-type R-DTI
Router(config-ptp-clk)#clock-port slave-port slave profile g8275.2
Router(config-ptp-port)# delay-req interval -4
Router(config-ptp-port)# sync interval -4
Router(config-ptp-port)# sync one-step
Router(config-ptp-port)# transport ipv6 unicast interface Lo1588 negotiation
Router(config-ptp-port)# clock source ipv6 2001:158:158:158::158
```

## Configuring an IPv4 Single Clock Source

To configure IPv4 single clock source, run the following steps:

```
ptp clock ordinary domain <domain id>
servo tracking-type R-DTI
clock-port <name> slave profile g8275.2
delay-req interval < Interval>
sync interval < Interval>
sync one-step
transport ipv4 unicast interface <loopback name> negotiation
clock source <clock ip>
```

## Configuring an IPv6 Single Clock Source

To configure IPv6 single clock source, run the following steps:

```
ptp clock ordinary domain <domain id>
servo tracking-type R-DTI
clock-port <name> slave profile g8275.2
delay-req interval < Interval>
sync interval < Interval>
sync one-step
transport ipv6 unicast interface <loopback name> negotiation
clock source ipv6 <clock ip>
```

## Verifying the G.8275.2 Profile

To verify the G.8275.2 profile, run the following command:

```
Router# show run | se ptp
ptp clock ordinary domain 55
servo tracking-type R-DTI
clock-port slave-port slave profile g8275.2
delay-req interval -4
sync interval -4
sync one-step
transport ipv6 unicast interface Lo1588
negotiation
clock source ipv6 2001:158:158:158::158
```

## Configuration Examples

The following example shows IPv4 single clock source configuration:

```
ptp clock ordinary domain 55
servo tracking-type R-DTI
clock-port slave-from-903 slave profile g8275.2
delay-req interval -4
sync interval -5
sync one-step
transport ipv4 unicast interface Lo1588 negotiation
clock source 10.90.3.93
```

The following example shows IPv6 single clock source configuration:

```
ptp clock ordinary domain 55 profile g8275.2
servo tracking-type R-DTI
clock-port slave-from-903 slave profile g8275.2
```

```
delay-req interval -4
sync interval -5
sync one-step
transport ipv6 unicast interface Lo1588 negotiation
clock source ipv6 2001:10:90:3::93
```

## DPIC PTP Primary

Effective Cisco IOS XE Fuji 16.12.1y, Cisco cBR Converged Broadband router provides support for Digital Physical Interface Card (DPIC) Precision Time Protocol (PTP) Primary. With the DPIC PTP Primary feature, RPD syncs to the PTP primary with some switch between them.



---

**Note** The DPIC PTP Primary feature is only supported on DPIC40, and not supported on DPIC100.

---

The DPIC PTP Primary feature has the following capabilities:

- PTP primary works as ordinary clock (OC mode) when using default profile.
- PTP primary works as Boundary clock (BC mode limited) only when using G8275.2 Profile.
- Supports PTP One-step mode
- Supports IPv4/IPv6 UDP PTP packets
- Supports up to 200 RPDs, 100 RPDs when ptp redundancy is configured.
- Supports G8275.2 Profile
- Supports SUPHA and LCHA configurations



---

**Note** The following scenarios are not supported:

- PTP packets that are sent and received through SUPPIC or DPIC100.
  - Boundary clock mode with both primary and subordinate clock port.
  - Two-step mode.
  - Dual Stack (IPv4/v6).
- 

## Configuring DPIC PTP Primary

The DPIC PTP Primary configuration involves the following steps in sequence:

### 1. Basic setup

- a. Configure cBR as PTP Primary with its loopback interface.

Ensure that the IP address of cBR loopback interface and RPD core interface should be in global or same VPN Routing/Forwarding (VRF).

- b. In RPD, configure cBR loopback as its PTP Primary IP.
- c. Ensure that the RPD uses its core interface IP as its PTP Gateway.



---

**Note** The PTP traffic between cBR loopback interface and RPD are routed through the RPD core interface. Therefore, IP address of the cBR loopback interface and RPD core interface should be in global or same VRF.

---

## 2. PTP setup redundancy

If Line Card High Availability (LCHA) is configured, RPD uses the corresponding DPIC interface on standby LC as it is an alternate clock source and gateway. Use the following snippet to configure the LCHA for PTP redundancy:

```
ptp r-dti <id>
ptp-domain <domain id>
clock-port <port id>
  clock source <ip address> gateway ip <ip address >
  clock source <ip address> gateway ip <ip address >alternate
```

## 3. Configure using either of the following formats:

- With Default Profile
  - For cBR PTP configuration:

```
ptp clock ordinary domain <domain id>
servo tracking-type R-DTI
clock-port <port_name0> master
  sync interval <interval>
  sync one-step
  transport <ipv4/ipv6> unicast interface <loopback0> negotiation
clock-port <port_name1> master
  sync interval <interval>
  sync one-step
  transport <ipv4/ipv6> unicast interface <loopback1> negotiation
clock-port <port_name2> master
  sync interval <interval>
  sync one-step
  transport <ipv4/ipv6> unicast interface <loopback2> negotiation
.
.
.
clock-port <port_name63> master
  sync interval <interval>
  sync one-step
  transport <ipv4/ipv6> unicast interface <loopback63> negotiation
```



---

**Note** cBR supports up to 64 clock-ports.

---

- For RPD PTP configuration:

```
ptp r-dti <id>
ptp-domain <domain id>
clock-port <port id>
```

```

    ethernet x
    [transport ipv6]
    clock source [ipv6] <ip address> gateway ip <ip address >
    clock source [ipv6] <ip address> gateway ip <ip address >alternate

```



---

**Note** The gateway ip is the active and standby core interface

---

- With G8275.2 Profile
  - For cBR PTP configuration:

```

ptp clock boundary domain <domain id>
servo tracking-type R-DTI
clock-port <port_name0> master profile G8275.2
sync interval <interval>
sync one-step
transport <ipv4/ipv6> unicast interface <loopback0> negotiation
clock-port <port_name1> master profile G8275.2
sync interval <interval>
sync one-step
transport <ipv4/ipv6> unicast interface <loopback1> negotiation
clock-port <port_name2> master profile G8275.2
sync interval <interval>
sync one-step
transport <ipv4/ipv6> unicast interface <loopback2> negotiation
.
.
.
clock-port <port_name63> master profile G8275.2
sync interval <interval>
sync one-step
transport <ipv4/ipv6> unicast interface <loopback63> negotiation

```



---

**Note** By the ITU G8275.2 Profile specification, the ordinary clock supports only one clock-port with G8275.2 Profile. You need to use the boundary clock if you have scenarios where multiple clock-ports are required.

---

- For RPD PTP configuration:

```

ptp r-dti <id>
profile G.8275.2
ptp-domain <domain id>
clock-port <port id>
  ethernet x
  [transport ipv6]
  clock source [ipv6] <ip address> gateway ip <ip address >
  clock source [ipv6] <ip address> gateway ip <ip address >alternate

```



---

**Note** The gateway IP is the active and standby core interface.

---



## Verifying the DPIC PTP Primary

Use the following options to verify your DPIC PTP Primary configuration:

- To check the cBR and RPD PTP configuration, use the **show run | se ptp** command. The syntax is as follows:

```
show run | se ptp

ptp clock boundary domain <domain id>
servo tracking-type R-DTI
clock-port <port_name0> master profile G8275.2
  sync interval <interval>
  sync one-step
  transport <ipv4/ipv6> unicast interface <loopback0> negotiation
clock-port <port_name1> master profile G8275.2
  sync interval <interval>
  sync one-step
  transport <ipv4/ipv6> unicast interface <loopback1> negotiation
clock-port <port_name2> master profile G8275.2
  sync interval <interval>
  sync one-step
  transport <ipv4/ipv6> unicast interface <loopback2> negotiation
.
.
.
clock-port <port_name63> master profile G8275.2
  sync interval <interval>
  sync one-step
  transport <ipv4/ipv6> unicast interface <loopback63> negotiation
```

- To check the PTP Primary state, you can use the **show ptp clock running domain <id>** command. See the following example:

```
Router# show ptp clock running domain 55
Load for five secs: 4%/0%; one minute: 4%; five minutes: 4%
Time source is NTP, 04:34:17.164 CST Tue Dec 19 2017
```

```

                                PTP Boundary Clock [Domain 55]

      State           Ports           Pkts sent           Pkts rcvd           Redundancy Mode
-----
FREQ_LOCKED         2                2005322             971815              Hot standby

                                PORT SUMMARY

Name Tx Mode      Role      Transport      State      Sessions      PTP Master
Port Addr
---
22  unicast      master    Lo1588         Master     2             -
33  unicast      master    Lo1589         Master     2             -

                                SESSION INFORMATION

22 [Lo1588] [Sessions 2]

Peer addr                Pkts in   Pkts out   In Errs   Out Errs
```

```

2001:120:101:16:A94F:61DB:D324:76B4      240839      497336      0           0
2001:120:101:16:2827:F9A6:4332:81AF     245193      505541      0           0

```

```
33 [Lol589] [Sessions 2]
```

Peer addr	Pkts in	Pkts out	In Errs	Out Errs
2001:120:101:16:A94F:61DB:D324:76B4	240582	496880	0	0
2001:120:101:16:2827:F9A6:4332:81AF	245201	505565	0	0

Router#

- To check detailed stream statistics, use the **show platform software ptpd stat stream <id|ip>** command. For example:

```

Router# show platform software ptpd stat stream 2001:120:101:16:A94F:61DB:D324:76B4
Load for five secs: 5%/0%; one minute: 4%; five minutes: 4%
Time source is NTP, 04:40:43.466 CST Tue Dec 19 2017
IP-Address : 2001:120:101:16:a94f:61db:d324:76b4 Stream-Number: 0
SYNC Contract
Remaining Duration : 105 (secs), State : ACTIVE
Tx packets : 247592, Rx Packets : 0 Error Packets : 0
Announce Contract
Remaining Duration : 105 (secs), State : ACTIVE
Tx packets : 15490, Rx Packets : 0 Error Packets : 0
Delay-Response Contract
Remaining Duration : 101 (secs), State : ACTIVE
Tx packets : 246878, Rx Packets : 0 Error Packets : 0

```

```

Router# show platform software ptpd stat stream 0
Load for five secs: 3%/0%; one minute: 4%; five minutes: 4%
Time source is NTP, 04:40:26.810 CST Tue Dec 19 2017
LOCK STATUS : FREERUN
SYNC Packet Stats
Time elapsed since last packet: 0.0
Configured Interval : -4, Acting Interval -4
Tx packets : 247325, Rx Packets : 0
Last Seq Number : 0, Error Packets : 0
Delay Req Packet Stats
Time elapsed since last packet: 0.0
Configured Interval : 0, Acting Interval : -4
Tx packets : 0, Rx Packets : 246612
Last Seq Number : 26116, Error Packets : 0
Delay Response Packet Stats
Time elapsed since last packet: 0.0
Configured Interval : -4, Acting Interval : -4
Tx packets : 246612, Rx Packets : 0
Last Seq Number : 0, Error Packets : 0
Announce Packet Stats
Time elapsed since last packet: 0.0
Configured Interval : 0, Acting Interval : 0
Tx packets : 15474, Rx Packets : 0
Last Seq Number 0 Error Packets 0
Signalling Packet Stats
Time elapsed since last packet: 0.0
Configured Interval : 0, Acting Interval : 0
Tx packets : 162, Rx Packets : 162
Last Seq Number : 0, Error Packets : 0
Current Data Set
Offset from master : +0.000000000
Mean Path Delay : +0.000000000
Forward Path Delay : +0.000000000
Reverse Path Delay : +0.000000000

```

```

Steps Removed 0
General Stats about this stream
Packet rate : 0, Packet Delta (ns) : 0
Clock Stream handle : 0, Index : 0
Oper State : 3, Sub oper State : 6
Log mean sync Interval : 0, log mean delay req int : 0

```

- To check the RPD PTP state, you can use the following commands:
  - **show ptp clock 0 state** command is used to check the PTP state on RPD. For example:

```

Router# show ptp clock 0 state
apr state      : PHASE_LOCK
clock state    : SUB_SYNC
current tod    : 1423125872   Thu Feb  5 08:44:32 2015
active stream  : 0
==stream 0 :
port id       : 0
master ip     : 2001:158:158:158::158
stream state  : PHASE_LOCK
Master offset : -110
Path delay   : 957
Forward delay: 888
Reverse delay: 1026
Freq offset  : -418299
1Hz offset   : 40
==stream 1 :
port id       : 0
master ip     : 2001:158:158:158::159
stream state  : PHASE_LOCK
Master offset : -15
Path delay   : 969
Forward delay: 916
Reverse delay: 1023
Freq offset  : -418526
1Hz offset   : 47
Router#

```

- The **show ptp clock 0 statistics** command is used to check PTP packets statistics on RPD. See the following example usage:

```

Router# show ptp clock 0 statistics
AprState 4 :
          2@0-00:11:41.897          1@0-00:11:32.266          0@0-00:09:37.062
          4@0-00:09:17.861
ClockState 5 :
          5@0-00:12:02.947          4@0-00:11:59.305          3@0-00:11:55.663
          2@0-00:11:42.664          1@0-00:11:41.866
BstPktStrm 1 :
          0@0-00:09:10.010
StepTime 1 :
          773016962@0-00:11:01.145
AdjustTime 3 :
          12@0-00:13:57.520          -280@0-00:13:33.895          -1137@0-00:11:27.895
fwdFltr 0 :
          Total: 4828                      Drop: 513
          MEAN: 973                          stdDev: 974
          Threshold: -299027 ~ 300973        shrink: 85714
revFltr 0 :
          Total: 4827                      Drop: 513
          MEAN: 950                          stdDev: 951
          Threshold: -299050 ~ 300950        shrink: 85714

```

```

fwdFltr      1 :
              Total: 1507                      Drop: 256
              MEAN: 974                        stdDev: 975
              Threshold: -299026 ~ 1373        shrink: 42914
revFltr      1 :
              Total: 1505                      Drop: 257
              MEAN: 947                        stdDev: 947
              Threshold: 619 ~ 300947         shrink: 42904
streamId  msgType      rx      rxProcessed  lost      tx
0          SYNC         4828      4828      0          0
0          DELAY REQUEST 0          0          0          4827
0          P-DELAY REQUEST 0          0          0          0
0          P-DELAY RESPONSE 0          0          0          0
0          FOLLOW UP     0          0          0          0
0          DELAY RESPONSE 4827      4827      3          0
0          P-DELAY FOLLOWUP 0          0          0          0
0          ANNOUNCE     314       314       0          0
0          SIGNALING     5          5          0          5
0          MANAGEMENT   0          0          0          0
TOTAL          9974      9974      3          4832
1          SYNC         1507      1507      0          0
1          DELAY REQUEST 0          0          0          1505
1          P-DELAY REQUEST 0          0          0          0
1          P-DELAY RESPONSE 0          0          0          0
1          FOLLOW UP     0          0          0          0
1          DELAY RESPONSE 1505      1505      2          0
1          P-DELAY FOLLOWUP 0          0          0          0
1          ANNOUNCE     103       103       0          0
1          SIGNALING     2          2          0          7
1          MANAGEMENT   0          0          0          0
TOTAL          3117      3117      2          1512
Router#
    
```

## Feature Information for G.8275.2 Profile

Use Cisco Feature Navigator to find information about the platform support and software image support. Cisco Feature Navigator enables you to determine which software images support a specific software release, feature set, or platform. To access Cisco Feature Navigator, go to the <https://cfnng.cisco.com/> link. An account on the Cisco.com page is not required.



**Note** The following table lists the software release in which a given feature is introduced. Unless noted otherwise, subsequent releases of that software release train also support that feature.

**Table 22: Feature Information for G.8275.2 Profile**

Feature Name	Releases	Feature Information
G.8275.2 Profile	Cisco IOS XE Fuji 16.8.1	This feature was introduced in Cisco IOS XE Fuji 16.8.1 on Cisco cBR Series Converged Broadband Router.

Feature Name	Releases	Feature Information
DPIC PTP Primary	Cisco IOS XE Gibraltar 16.12.1y	This feature was introduced in Cisco IOS XE Gibraltar 16.12.1y on Cisco cBR Series Converged Broadband Router.





## CHAPTER 8

# Model-Driven Telemetry

---

This document provides information on the support for Model-Driven Telemetry and how to configure Cisco cBR series routers to avail the support.

Your software release may not support all the features that are documented in this module. For the latest feature information and caveats, see the release notes for your platform and software release. The Feature Information Table at the end of this document provides information about the documented features and lists the releases in which each feature is supported.

Use Cisco Feature Navigator to find information about platform support and Cisco software image support. To access Cisco Feature Navigator, go to <http://tools.cisco.com/ITDIT/CFN/>. An account on <http://www.cisco.com/> is not required.

- [Hardware Compatibility Matrix for the Cisco cBR Series Routers, on page 147](#)
- [Information About Model-Driven Telemetry, on page 149](#)
- [Restrictions for Model Driven Telemetry, on page 149](#)
- [Prerequisites to Enable Telemetry, on page 150](#)
- [Configuring Telemetry, on page 150](#)
- [Feature Information for Model-Driven Telemetry, on page 153](#)

## Hardware Compatibility Matrix for the Cisco cBR Series Routers



---

**Note** The hardware components that are introduced in a given Cisco IOS-XE Release are supported in all subsequent releases unless otherwise specified.

---

Table 23: Hardware Compatibility Matrix for the Cisco cBR Series Routers

Cisco CMTS Platform	Processor Engine	Interface Cards
Cisco cBR-8 Converged Broadband Router	<p><b>Cisco IOS-XE Release 16.5.1 and Later Releases</b></p> <p>Cisco cBR-8 Supervisor:</p> <ul style="list-style-type: none"> <li>• PID—CBR-SUP-250G</li> <li>• PID—CBR-CCAP-SUP-160G</li> </ul>	<p><b>Cisco IOS-XE Release 16.5.1 and Later Releases</b></p> <p>Cisco cBR-8 CCAP Line Cards:</p> <ul style="list-style-type: none"> <li>• PID—CBR-LC-8D30-16U30</li> <li>• PID—CBR-LC-8D31-16U30</li> <li>• PID—CBR-RF-PIC</li> <li>• PID—CBR-RF-PROT-PIC</li> <li>• PID—CBR-CCAP-LC-40G</li> <li>• PID—CBR-CCAP-LC-40G-R</li> <li>• PID—CBR-CCAP-LC-G2-R</li> <li>• PID—CBR-SUP-8X10G-PIC</li> <li>• PID—CBR-2X100G-PIC</li> </ul> <p>Digital PICs:</p> <ul style="list-style-type: none"> <li>• PID—CBR-DPIC-8X10G</li> <li>• PID—CBR-DPIC-2X100G</li> </ul> <p>Cisco cBR-8 Downstream PHY Module:</p> <ul style="list-style-type: none"> <li>• PID—CBR-D31-DS-MOD</li> </ul> <p>Cisco cBR-8 Upstream PHY Modules:</p> <ul style="list-style-type: none"> <li>• PID—CBR-D31-US-MOD</li> </ul>



**Note** Do not use DPICs (8X10G and 2x100G) to forward IP traffic, as it may cause buffer exhaustion, leading to line card reload.

The only allowed traffic on a DPIC interface is DEPI, UEPI, and GCP traffic from the Cisco cBR-8 router to Remote PHY devices. Other traffic such as DHCP, SSH, and UTSC should flow via another router, since DPICs cannot be used for normal routing.



# Information About Model-Driven Telemetry

Model-driven telemetry allows Cisco cBR-8 Converged Broadband Router to continuously stream real time configuration and operating state information to collectors. This module describes model-driven telemetry and provides sample telemetry RPCs.

Model-driven telemetry uses YANG models to express available data. Contents of supported YANG files can be retrieved from cBR8 directly. Collectors can subscribe to specific data items they need, by using these standard-based YANG data models. Telemetry can continuously stream data to the collector with periodical or on-change mode.

YANG-filed MIBs models, following DOCSIS MIBs are converted to YANG models, and they are automatically converted from legacy MIB file to YANG file. All the data for a converted MIB is received from the legacy SNMP agent and then sent to Telemetry receiver by gRPC/NETCONF.

Cisco IOS XE Gibraltar 16.12.1 on Cisco cBR Series Converged Broadband Router includes a native **Cisco-IOS-XE-docsis-oper** YANG file along with the YANG-filed MIB models. In the **Cisco-IOS-XE-docsis-oper** YANG file the output of some show commands will be modeled.



---

**Note** Ensure that you have enabled the **cable bgsync active** CLI for **Cisco-IOS-XE-docsis-oper**. The **Cisco-IOS-XE-docsis-oper** is required to get the correct data for cable modems.

---

- CISCO-CABLE-SPECTRUM-MIB
- CISCO-CABLE-WIDEBAND-MIB
- CISCO-DOCS-EXT-MIB
- DOCS-IF-MIB
- DOCS-IF3-MIB
- DOCS-QOS-MIB
- DOCS-SUBMGT3-MIB
- CISCO-ENVMON-MIB
- CISCO-PROCESS-MIB
- OLD-CISCO-INTERFACES-MIB
- SNMPv2-MIB
- ENTITY-MIB
- IF-MIB

## Restrictions for Model Driven Telemetry

Following are the restrictions on using the Model-Driven Telemetry:

- All DOCSIS-specific models are supported for periodical push. On-change push is not supported.
- For the same MIB model, a NETCONF subscription's performance is lower than the legacy SNMP walk.

## Prerequisites to Enable Telemetry

Run the following command to ensure that the prerequisites are in place to configure Telemetry:

```
conf t
ip ssh version 2
netconf-yang
netconf-yang cisco-ia snmp-community-string testing-mib-yang
snmp-server community testing-mib-yang RO
end
```

Ensure that you go through the following recommendations before configuring telemetry:

- Use the **show platform software yang-management process** command to verify that all related processes are running.
- The default listening tcp port number for NETCONF is 830. You can change the default port by using the **netconf-yang ssh port** CLI.
- An snmp-community-string is needed for gRPC/NETCONF to retrieve YANG filed MIB. The default snmp-community-string is 'private'.

## Configuring Telemetry

The following Telemetry protocols are supported on Cisco cBR-8 Converged Broadband Router:

- **gRPC**: gRPC only supports Dial-Out (Configured/Static). Initial connection starts from cBR8 triggered by CLI configuration.
- **NETCONF**: NETCONF only supports Dial-In (Dynamic). Initial connection starts from telemetry collectors.

## Configuring Telemetry using gRPC

The gRPC only supports the dial-out method. You need CLI configurations on cBR-8 to create a gRPC subscription.

To create a dial-out subscription, go through the following sample. Note that the parameters in bold cannot be changed.

```
Conf t
telemetry ietf subscription 100
encoding encode-kvgpb
filter xpath /IF-MIB:IF-MIB/ifTable/ifEntry[ifIndex=263975]
source-address 172.22.9.102
stream yang-push
update-policy periodic 3000
```

```
receiver ip address 10.79.41.133 57566 protocol grpc-tcp
end
```



---

**Note** Multiple target XPath is not supported.

---

To delete a subscription, run the **no telemetry ietf subscription 100** command.

The following show commands are supported for gRPC:

- **show telemetry ietf subscription configured detail**
- **show telemetry ietf subscription 100 receiver**

The following examples illustrate the usage of the show commands:

```
router# show telemetry ietf subscription configured detail
```

```
Telemetry subscription detail:
Subscription ID: 100
State: Valid
Stream: yang-push
Filter:
  Filter type: xpath
  XPath: /IF-MIB:IF-MIB/ifTable/ifEntry[ifIndex=263975]
Update policy:
  Update Trigger: periodic
  Period: 3000
Encoding: encode-kvgpb
Source VRF: Mgmt-intf
Source Address: 172.22.9.102
Notes:
```

```
Receivers:
  Address                               Port      Protocol      Protocol Profile
-----
  10.79.41.133                          57566     grpc-tcp
```

```
router# show telemetry ietf subscription 100 receiver
Telemetry subscription receivers detail:
```

```
Subscription ID: 100
Address: 10.79.41.133
Port: 57566
Protocol: grpc-tcp
Profile:
State: Connected
Explanation:
```



---

**Note**

- A **Valid** state denotes that the configuration is good and accepted.
- A **Connected** state denotes that the TCP connection is established.

---

## Configuring Telemetry using NETCONF

The NETCONF communication happens in the following sequence:

1. Connect to device. Say **<hello>**.
2. Retrieve **<capabilities>**.
3. Investigate and choose the appropriate model.
4. Compose operation.
5. Send message **<rpc>**.
6. Retrieve **<rpc-reply>**.
7. Process **<data>**.

The following example lists how a Telemetry subscriber subscribes to an instances in an MIB:

```
<establish-subscription
  xmlns="urn:ietf:params:xml:ns:yang:ietf-event-notifications"
  xmlns:yp="urn:ietf:params:xml:ns:yang:ietf-yang-push">
  <stream>yp:yang-push</stream>

  <yp:xpath-filter>/IF-MIB:IF-MIB/ifTable/ifEntry[ifIndex=&quot;263975&quot;]</yp:xpath-filter>
  <yp:period>3000</yp:period>
</establish-subscription>

<rpc-reply xmlns="urn:ietf:params:xml:ns:netconf:base:1.0" message-id="2">
<subscription-result xmlns='urn:ietf:params:xml:ns:yang:ietf-event-notifications'
xmlns:notif-bis="urn:ietf:params:xml:ns:yang:ietf-event-notifications">notif-bis:ok</subscription-result>
<subscription-id
xmlns='urn:ietf:params:xml:ns:yang:ietf-event-notifications'>2147483655</subscription-id>
</rpc-reply>
```



- 
- Note**
- The **ifIndex** option lists the model defined in the YANG file.
  - The **yp:period** lists the expected time interval between push updates (3000 centisecond in this example).
- 

The following is an example of the show or delete NETCONF subscription option:

```
Router# show telemetry ietf subscription 2147483655 detail
Telemetry subscription detail:
Subscription ID: 2147483655
Type: Dynamic
State: Valid
Stream: yang-push
Filter:
  Filter type: xpath
  XPath: /IF-MIB:IF-MIB/ifTable/ifEntry[ifIndex="263975"]
Update policy:
  Update Trigger: periodic
  Period: 3000
Encoding: encode-xml
Source VRF:
```

```

Source Address:
Notes:
Receivers:
  Address                               Port      Protocol      Protocol Profile
-----
10.79.41.133                            38914    netconf
Router# clear telemetry ietf subscription 2147483655

```

## Feature Information for Model-Driven Telemetry

Use Cisco Feature Navigator to find information about the platform support and software image support. Cisco Feature Navigator enables you to determine which software images support a specific software release, feature set, or platform. To access Cisco Feature Navigator, go to the <https://cfng.cisco.com/> link. An account on the Cisco.com page is not required.



**Note** The following table lists the software release in which a given feature is introduced. Unless noted otherwise, subsequent releases of that software release train also support that feature.

**Table 24: Feature Information for Model-Driven Telemetry**

Feature Name	Releases	Feature Information
Model-Driven Telemetry	Cisco IOS XE Gibraltar 16.12.1	This feature was introduced in Cisco IOS XE Gibraltar 16.12.1 on Cisco cBR Series Converged Broadband Router.





## PART II

# High Availability Configuration

- [Cisco IOS-XE In-Service Software Upgrade Process, on page 157](#)
- [Supervisor Redundancy, on page 163](#)
- [Line Card Redundancy, on page 179](#)







## CHAPTER 9

# Cisco IOS-XE In-Service Software Upgrade Process

---

Cisco cBR-8 Routers support the In-Service Software Upgrades (ISSU) for redundant platforms.

Your software release may not support all the features that are documented in this module. For the latest feature information and caveats, see the release notes for your platform and software release. The Feature Information Table at the end of this document provides information about the documented features and lists the releases in which each feature is supported.

Use Cisco Feature Navigator to find information about platform support and Cisco software image support. To access Cisco Feature Navigator, go to <http://tools.cisco.com/ITDIT/CFN/>. An account on <http://www.cisco.com/> is not required.

### Contents

- [Hardware Compatibility Matrix for the Cisco cBR Series Routers, on page 157](#)
- [Information about In-Service Software Upgrade, on page 159](#)
- [How to Configure In-Service Software Upgrade, on page 159](#)
- [Additional References, on page 162](#)
- [Feature Information for In-Service Software Upgrade, on page 162](#)

## Hardware Compatibility Matrix for the Cisco cBR Series Routers



---

**Note** The hardware components that are introduced in a given Cisco IOS-XE Release are supported in all subsequent releases unless otherwise specified.

---

Table 25: Hardware Compatibility Matrix for the Cisco cBR Series Routers

Cisco CMTS Platform	Processor Engine	Interface Cards
Cisco cBR-8 Converged Broadband Router	<p><b>Cisco IOS-XE Release 16.5.1 and Later Releases</b></p> <p>Cisco cBR-8 Supervisor:</p> <ul style="list-style-type: none"> <li>• PID—CBR-SUP-250G</li> <li>• PID—CBR-CCAP-SUP-160G</li> </ul>	<p><b>Cisco IOS-XE Release 16.5.1 and Later Releases</b></p> <p>Cisco cBR-8 CCAP Line Cards:</p> <ul style="list-style-type: none"> <li>• PID—CBR-LC-8D30-16U30</li> <li>• PID—CBR-LC-8D31-16U30</li> <li>• PID—CBR-RF-PIC</li> <li>• PID—CBR-RF-PROT-PIC</li> <li>• PID—CBR-CCAP-LC-40G</li> <li>• PID—CBR-CCAP-LC-40G-R</li> <li>• PID—CBR-CCAP-LC-G2-R</li> <li>• PID—CBR-SUP-8X10G-PIC</li> <li>• PID—CBR-2X100G-PIC</li> </ul> <p>Digital PICs:</p> <ul style="list-style-type: none"> <li>• PID—CBR-DPIC-8X10G</li> <li>• PID—CBR-DPIC-2X100G</li> </ul> <p>Cisco cBR-8 Downstream PHY Module:</p> <ul style="list-style-type: none"> <li>• PID—CBR-D31-DS-MOD</li> </ul> <p>Cisco cBR-8 Upstream PHY Modules:</p> <ul style="list-style-type: none"> <li>• PID—CBR-D31-US-MOD</li> </ul>



**Note** Do not use DPICs (8X10G and 2x100G) to forward IP traffic, as it may cause buffer exhaustion, leading to line card reload.

The only allowed traffic on a DPIC interface is DEPI, UEPI, and GCP traffic from the Cisco cBR-8 router to Remote PHY devices. Other traffic such as DHCP, SSH, and UTSC should flow via another router, since DPICs cannot be used for normal routing.

# Information about In-Service Software Upgrade

Cisco cBR-8 Routers support the In-Service Software Upgrades (ISSU) for redundant platforms. The ISSU process allows software to be updated or otherwise modified while packet forwarding continues with the benefit of LCHA.

For the Cisco cBR Series Routers, ISSU-compatibility depends on the software subpackage being upgraded and the hardware configuration.

The specific procedures in this document represent supported and tested installation sequences. The Cisco IOS-XE system software allows other installation sequences for special purposes under the guidance of Cisco customer support representatives, but the steps in this document should be followed otherwise. These steps should be followed completely, as the Cisco cBR Series Routers are designed to run one version of Cisco IOS-XE on an SUP, and running subpackages from different versions of Cisco IOS-XE can cause unexpected router behavior.

## How to Configure In-Service Software Upgrade

This section describes the configuration of the ISSU feature:

### Configuring Subpackage Upgrade

#### Subpackages Upgrade

Subpackage upgrade allows a subset of the running software to be upgraded. It is intended for patching small and targeted fix instead of full image upgrade. Subpackage upgrade supports both single and dual SUP setup.

#### Single SUP Subpackages Upgrade

##### Before you begin

Be sure to complete the following prerequisites before running the ISSU process:

- Config register autoboot enabled.
- Target patch copied to active SUP in the same directory of the packages.conf file system is booted up with.
- If needed copy patch info file to SUP.
- Enough bootflash disk space on SUP.

##### Procedure

	Command or Action	Purpose
Step 1	<p><b>enable</b></p> <p><b>Example:</b></p> <pre>Router&gt; enable</pre>	<p>Enables privileged EXEC mode.</p> <ul style="list-style-type: none"> <li>• Enter your password if prompted.</li> </ul>

	Command or Action	Purpose
<b>Step 2</b>	<b>request platform software package install rp <i>rp-slot</i> file bootflash:</b>  <b>Example:</b>  <pre>Router# request platform software package install rp 1 file bootflash:cbrsup-universalk9.03.17.00.S.156-1.S-std.SPA.bin</pre>	Upgrades the cBR-8 router with one SUP using subpackages ISSU procedure.

## Dual SUPs Subpackages Upgrade

### Before you begin

Be sure to complete the following prerequisites before running the ISSU process:

- Standby SUP must be in hot standby.
- Config register autoboot enabled.
- Both SUP in sub-package mode, running same base image and patches from same path.
- Target patch copied to active SUP in the same directory of the packages.conf file system is booted up with.
- If needed copy patch info file to both SUPs.
- Enough bootflash disk space on both SUPs.

### Procedure

	Command or Action	Purpose
<b>Step 1</b>	<b>enable</b>  <b>Example:</b>  <pre>Router&gt; enable</pre>	Enables privileged EXEC mode. <ul style="list-style-type: none"> <li>• Enter your password if prompted.</li> </ul>
<b>Step 2</b>	<b>request platform software package install node file bootflash:</b>  <b>Example:</b>  <pre>Router# request platform software package install node file bootflash:cbrsup-universalk9.03.17.00.S.156-1.S-std.SPA.bin</pre>	Upgrades the cBR-8 router with dual SUPs using subpackages ISSU procedure.

## Line Card Only In-Service Software Upgrade

If the upgrade fails or you cancel manually at line card upgrade stage, you can initiate a line card only upgrade.

Use the **request platform software package install node linecard-only** command to upgrade only the line card to the same version as the one in the current active SUP, the customer can choose to upgrade one line card or all the line cards in the chassis.

Use this command together with the **request platform software package install node file *file-path* noreload linecard** command to upgrade SUP first, and then upgrade the line card.

## Procedure

	Command or Action	Purpose
<b>Step 1</b>	<b>enable</b> <b>Example:</b> Router> <b>enable</b>	Enables privileged EXEC mode. Enter your password if prompted.
<b>Step 2</b>	<b>request platform software package install node linecard-only</b> <b>Example:</b> Router# <b>request platform software package install node linecard-only all</b>	Upgrade all line cards to the same version as the one in the current active SUP.

## ISSU Upgrade Across Major Releases

Starting from Cisco IOS XE Fuji 16.7.1 release, ISSU can upgrade cbr-8 between major releases.

**Step 1** Copy the base image to active and standby SUPs. Copy the ISSU target image to active SUP.

```
copy <location>/<base_image> <location_active_sup>
copy <location>/<base_image> <location_standby_sup>
copy <location>/<target_image> <location_active_sup>
```

**Step 2** Expand base image to both SUPs at the same folder.

```
request platform software package expand file <location_active_sup>/<base_image>
request platform software package expand file <location_standby_sup>/<base_image>
```

**Step 3** Config register for auto boot (eg) config-reg 0x2102.

```
config-register 0x2102
boot system <location_active_sup>/packages.conf
```

**Step 4** Save then reload router via subpackage mode.

```
reload
```

**Step 5** After boot up, verify base image loaded using **show version running** and check more.

**Step 6** Copy the target image to active SUP in the same location as before.

```
copy <location>/<target_image> <location_active_sup>
```

**Step 7** Using Request command to do ISSU.

```
request platform software package install node file <location_active_sup>/<target_image>
```

## Additional References

The following sections provide references related to the ISSU feature.

### Technical Assistance

Description	Link
The Cisco Support and Documentation website provides online resources to download documentation, software, and tools. Use these resources to install and configure the software and to troubleshoot and resolve technical issues with Cisco products and technologies. Access to most tools on the Cisco Support and Documentation website requires a Cisco.com user ID and password.	<a href="http://www.cisco.com/cisco/web/support/index.html">http://www.cisco.com/cisco/web/support/index.html</a>

## Feature Information for In-Service Software Upgrade

Use Cisco Feature Navigator to find information about the platform support and software image support. Cisco Feature Navigator enables you to determine which software images support a specific software release, feature set, or platform. To access Cisco Feature Navigator, go to the <https://cfng.cisco.com/> link. An account on the Cisco.com page is not required.



**Note** The following table lists the software release in which a given feature is introduced. Unless noted otherwise, subsequent releases of that software release train also support that feature.

**Table 26: Feature Information for ISSU**

Feature Name	Releases	Feature Information
ISSU	Cisco IOS XE Fuji 16.7.1	This feature was integrated on the cisco cBR Series Converged Broadband Routers.



## CHAPTER 10

# Supervisor Redundancy

The Supervisor Redundancy feature reduces unplanned downtime. It enables a quicker switchover between active and standby Supervisors when a fatal error occurs on the active Supervisor. When you configure Supervisor Redundancy, the standby Supervisor is synchronized with the active Supervisor. If a fatal error occurs on the active Supervisor, the system immediately switches to the standby Supervisor.

Your software release may not support all the features that are documented in this module. For the latest feature information and caveats, see the release notes for your platform and software release. The Feature Information Table at the end of this document provides information about the documented features and lists the releases in which each feature is supported.

Use Cisco Feature Navigator to find information about platform support and Cisco software image support. To access Cisco Feature Navigator, go to <http://tools.cisco.com/ITDIT/CFN/>. An account on <http://www.cisco.com/> is not required.

### Contents

- [Hardware Compatibility Matrix for the Cisco cBR Series Routers, on page 163](#)
- [Prerequisites for Supervisor Redundancy, on page 165](#)
- [Information About Supervisor Redundancy, on page 165](#)
- [How to Configure Supervisor Redundancy, on page 168](#)
- [Verifying the Supervisor Redundancy Configuration, on page 173](#)
- [Configuration Example for Supervisor Redundancy, on page 177](#)
- [Additional References, on page 178](#)
- [Feature Information for Supervisor Redundancy, on page 178](#)

## Hardware Compatibility Matrix for the Cisco cBR Series Routers



---

**Note** The hardware components that are introduced in a given Cisco IOS-XE Release are supported in all subsequent releases unless otherwise specified.

---

Table 27: Hardware Compatibility Matrix for the Cisco cBR Series Routers

Cisco CMTS Platform	Processor Engine	Interface Cards
Cisco cBR-8 Converged Broadband Router	<p><b>Cisco IOS-XE Release 16.5.1 and Later Releases</b></p> <p>Cisco cBR-8 Supervisor:</p> <ul style="list-style-type: none"> <li>• PID—CBR-SUP-250G</li> <li>• PID—CBR-CCAP-SUP-160G</li> </ul>	<p><b>Cisco IOS-XE Release 16.5.1 and Later Releases</b></p> <p>Cisco cBR-8 CCAP Line Cards:</p> <ul style="list-style-type: none"> <li>• PID—CBR-LC-8D30-16U30</li> <li>• PID—CBR-LC-8D31-16U30</li> <li>• PID—CBR-RF-PIC</li> <li>• PID—CBR-RF-PROT-PIC</li> <li>• PID—CBR-CCAP-LC-40G</li> <li>• PID—CBR-CCAP-LC-40G-R</li> <li>• PID—CBR-CCAP-LC-G2-R</li> <li>• PID—CBR-SUP-8X10G-PIC</li> <li>• PID—CBR-2X100G-PIC</li> </ul> <p>Digital PICs:</p> <ul style="list-style-type: none"> <li>• PID—CBR-DPIC-8X10G</li> <li>• PID—CBR-DPIC-2X100G</li> </ul> <p>Cisco cBR-8 Downstream PHY Module:</p> <ul style="list-style-type: none"> <li>• PID—CBR-D31-DS-MOD</li> </ul> <p>Cisco cBR-8 Upstream PHY Modules:</p> <ul style="list-style-type: none"> <li>• PID—CBR-D31-US-MOD</li> </ul>



**Note** Do not use DPICs (8X10G and 2x100G) to forward IP traffic, as it may cause buffer exhaustion, leading to line card reload.

The only allowed traffic on a DPIC interface is DEPI, UEPI, and GCP traffic from the Cisco cBR-8 router to Remote PHY devices. Other traffic such as DHCP, SSH, and UTSC should flow via another router, since DPICs cannot be used for normal routing.



## Prerequisites for Supervisor Redundancy

- Two Supervisors (that is, two Supervisor Cards and two Supervisor PICs) must be installed in the Cisco cBR chassis.
- Both Supervisors must be running identical software releases. If there is release mismatch, when inserting the standby Supervisor, either the standby Supervisor or the active Supervisor may be impacted, even reloaded. So before inserting the new standby Supervisor, make sure it will boot with the identical software release as the active Supervisor.

## Information About Supervisor Redundancy

The Supervisor redundancy feature enables the Cisco cBR router to use two Supervisors in a redundant configuration, so that if the active Supervisor fails or becomes inactive, the system automatically performs a switchover, where the standby Supervisor takes over and assumes full responsibility for systems operations.

The Supervisor redundancy feature does not require a full reboot of the system to perform a switchover. When the system boots up, the standby Supervisor performs full initialization, which includes self initialization, running configuration synchronization from the active Supervisor, and SSO feature data synchronization from the active Supervisor, then it enters into hot standby state and monitors the active Supervisor. If the standby Supervisor detects a failure in the active Supervisor, it can quickly assume the active responsibility for systems operations.

Each Supervisor contains all the resources required to operate the router, such as bootflash memory, hard disks, Ethernet ports, and console port. In the default operation, the standby Supervisor also synchronizes the major systems files, such as the running configuration file, so that during a switchover, the standby Supervisor can duplicate the active Supervisor's configuration.

You can use Cisco IOS CLI commands to access the standby Supervisor resources, such as the bootflash and hard disk. For example, you can use the **dir** command to list the contents of a device, or use the **copy** command to transfer files between the active and standby Supervisor.

## Switchover Procedure

A switchover occurs when the standby Supervisor takes over responsibilities from the active Supervisor. The switchover can occur automatically if the standby Supervisor has determined that the active Supervisor has failed, or an operator can initiate a manual switchover whenever desired.

A switchover triggers the following events:

1. If this is a manual switchover, the active Supervisor verifies that the standby Supervisor is present and has entered into SSO. If so, it instructs the standby Supervisor to begin switchover procedures, and the active Supervisor either attempts to reload its configured Cisco IOS software image or enters ROM monitor mode, depending on the setting of its configuration register.
2. The standby Supervisor assumes responsibility as the active Supervisor and brings the Cisco cBR chassis into active state, and continues the service as active Supervisor.
3. The new active Supervisor begins normal systems operations, including passing traffic.



---

**Note** The Supervisor does not begin functioning as a standby Supervisor until it is booted up with a proper Cisco IOS software.

---

### Is Supervisor Switchover Failing?

The usual phenomenon for a Supervisor switchover to be affected is when the active Supervisor has these issues:

- Supervisor hangs
- Login to Supervisor console or Telnet to chassis fails
- Interface cards unable to connect to active Supervisor, hence crashing
- Cable modems drop offline
- Chassis reload required
- Reset of active Supervisor required to restore service



---

**Note** In case there is hardware issue with the Supervisor, do not reinsert the faulty Supervisor in the chassis. Inserting a faulty Supervisor (although a standby Supervisor) may cause the interface card to switch to the faulty Supervisor causing the interface card to crash and cable modems to go offline.

---

## Using Redundant File Systems

Both the active and standby Supervisors have active file systems that can be accessed to store and transfer files. The table below lists the available file systems, the filenames that you can use with CLI commands to access the file systems, and a short description of each.

File System	File Name for CLI Commands	Description
<ul style="list-style-type: none"> <li>• Bootflash</li> <li>• Flash</li> <li>• Hard disk</li> <li>• USB</li> <li>• Standby bootflash</li> <li>• Standby hard disk</li> <li>• Standby USB</li> </ul>	<ul style="list-style-type: none"> <li>• bootflash:</li> <li>• flash:</li> <li>• harddisk:</li> <li>• usb0:</li> <li>• usb1:</li> <li>• stby-bootflash:</li> <li>• stby-harddisk:</li> <li>• stby-usb0:</li> <li>• stby-usb1:</li> </ul>	Stores image, crash file, core files, saved configuration files, and various user files.

File System	File Name for CLI Commands	Description
<ul style="list-style-type: none"> <li>• System</li> <li>• Temporary system</li> <li>• Null</li> <li>• Tar</li> <li>• Syslog</li> <li>• CNS</li> <li>• RCSF</li> </ul>	<ul style="list-style-type: none"> <li>• system:</li> <li>• tmpsys:</li> <li>• null:</li> <li>• tar:</li> <li>• syslog:</li> <li>• cns:</li> <li>• revrcsf:</li> </ul>	Stores the running configuration and other system files.
<ul style="list-style-type: none"> <li>• NVRAM</li> <li>• Standby NVRAM</li> <li>• Standby RCSF</li> </ul>	<ul style="list-style-type: none"> <li>• nvram:</li> <li>• stby-nvram:</li> <li>• stby-rcsf:</li> </ul>	Typically stores the system default configuration file and startup configuration file.
<ul style="list-style-type: none"> <li>• TFTP</li> <li>• RCP</li> <li>• PRAM</li> <li>• FTP</li> <li>• HTTP</li> <li>• SCP</li> <li>• HTTPS</li> </ul>	<ul style="list-style-type: none"> <li>• tftp:</li> <li>• rcp:</li> <li>• pram:</li> <li>• ftp:</li> <li>• http:</li> <li>• scp:</li> <li>• https:</li> </ul>	Protocols used to transfer files to and from remote devices.

You can use the privileged EXEC commands **dir**, **del**, and **copy** to manage the contents of the file systems. You can also use the commands **mkdir** and **rmdir** to create and remove directories on bootflash or hard disks.

Following is a sample output of the **show file systems** command on the Cisco cBRrouter:

```
Router# show file systems
```

```
File Systems:
```

```
Size (b)      Free (b)      Type  Flags  Prefixes
-           -           -    opaque rw  system:
-           -           -    opaque rw  tmpsys:
* 7800705024  1574408192   disk  rw    bootflash:
7800705024  1574408192   disk  rw    flash:
98394218496  79534682112  disk  rw    harddisk:
8009056256   8009023488   disk  rw    usb1:
33554432     33507452     nvram rw    stby-nvram:
-           -           -    opaque rw    null:
-           -           -    opaque ro    tar:
-           -           network rw    tftp:
-           -           opaque wo    syslog:
33554432     33508476     nvram rw    nvram:
-           -           network rw    rcp:
-           -           network rw    pram:
```

```

-          - network rw ftp:
-          - network rw http:
-          - network rw scp:
-          - network rw https:
-          - opaque ro cns:
-          - nvram rw stby-rcsf:
7800705024 1635270656 disk rw stby-bootflash:
98394218496 89040576512 disk rw stby-harddisk:
-          - disk rw stby-usb0:
1000787968 301559808 disk rw stby-usb1:
-          - opaque rw revrcsf:

```

## Console Port Usage After Supervisor Switchover

When an active Supervisor fails, and the standby Supervisor becomes the active Supervisor, you must use the console port on the new active Supervisor to give CLI commands and display statistics for the router. The standby Supervisor console is disabled by default and cannot be used to run any CLI commands. Following is an sample output of the standby Supervisor console:

```

Router-stby>
Standby console disabled
Router-stby>

```

To access the console, move the PC or terminal's serial cable to the console port on the other Supervisor, which is now acting as the active Supervisor.

## Benefits

- The Supervisor is not a single point of hardware failure. If a permanent hardware failure in the active Supervisor occurs, the standby Supervisor recovers the system, increasing the level of network service and reliability.
- The standby Supervisor can become the active Supervisor without the manual intervention of a system operator. This reduces the recovery time and the need for an instant response from the network administrators.
- The active Supervisor continues to dynamically synchronize the changed configuration and feature data with the standby Supervisor after the system reaches SSO. Therefore, the standby Supervisor always operates as a hot standby and ready to take over.

## How to Configure Supervisor Redundancy

The Supervisor redundancy feature is automatically enabled when two Supervisor are installed in the Cisco cBR chassis. The active Supervisor automatically synchronizes the running configuration file with the standby Supervisor during the bootup of standby Supervisor.



---

**Note** The Cisco cBR router supports only the SSO mode for Supervisor redundancy. The default redundancy mode is SSO and this mode does not need any new configurations.

---

This section contains the following:

## Forcing Switchover

To manually force a switchover, so that the standby Supervisor becomes active, use the **redundancy force-switchover** command in privileged EXEC mode on the active Supervisor. Manually forcing a switchover is useful in the following situations:

- You need to remove, replace, or upgrade the currently active Supervisor.
- A previous switchover has activated the standby Supervisor and you now want to restore the previously active Supervisor.



**Tip** Simply removing the active Supervisor also triggers a switchover, but using the **redundancy force-switchover** command does not generate a hardware alarm.

### Before you begin

Ensure that the standby Supervisor is in the SSO state using the **show redundancy** command. For more information, see [Verifying Supervisor Redundancy](#), on page 173.

**Step 1** Set the configuration register as 0x02 and the load the appropriate image on both the Supervisors

#### Example:

```
Router# configure terminal
Router(config)# config-register 0x02
Router(config)# boot system bootflash:cbrsup-universalk9.2015-03-08_01.38_xxxxx.SSA.bin
```

**Note** Do not perform this step if you want to set the previous active Supervisor to stay in ROM monitor mode or manually boot it up after the switchover.

**Step 2** Use the **redundancy force-switchover** command to force the switchover.

#### Example:

```
Router# redundancy force-switchover

Proceed with switchover to standby RP? [confirm]
Manual Swact = enabled

Jan 1 19:23:22.483 R0/0: %PMAN-5-EXITACTION: Process manager is exiting: process exit with reload
fru code

Initializing Hardware ...

System Bootstrap, Version 12.2(20141120:061458) [153], DEVELOPMENT SOFTWARE
Copyright (c) 1994-2014 by cisco Systems, Inc.
Compiled Thu 11/20/2014 18:04:24.91 by xxxxx
```

The standby Supervisor becomes the active Supervisor.

- Step 3** (Optional) If you have not performed [Step 1, on page 169](#), the previous active Supervisor is put into the ROM monitor mode after the switchover. To enable the previous active Supervisor to become the new standby Supervisor, manually boot up the new standby Supervisor to enter into SSO mode.

## Changing the System Boot Behavior

This section describes how to change the Cisco IOS software configuration register for modifying the system behavior when powering up or rebooting the system. The software configuration register is a 16 bit register in NVRAM that controls the following boot functions:

- Specifies the source of the Cisco IOS software image to be loaded
- Specifies whether the Cisco IOS software must ignore the contents of the saved configuration file in NVRAM memory
- Enables or disables the use of the Break function

Use the following procedure to change the software configuration register settings:

- Step 1** Enter global configuration mode and use the **config-register** command to set the contents of the software configuration register to a new value.

Specify the new value as a 16 bit hexadecimal bitmask by using the values provided in the following table.

**Table 28: Definition of Bits in the Software Configuration Register**

Bit No.	Hex Value	Meaning/Function
00 to 03	0x0000 to 0x000F	Defines the source of the default Cisco IOS software image required to run the router: <ul style="list-style-type: none"> <li>• 00—When powering up, the system remains at the ROM monitor prompt (rommon), awaiting a user command to boot the system manually by the rommon <b>boot</b> command.</li> <li>• 01—When powering up, the system automatically boots the first system image found in the flash memory's single in-line memory module (SIMM) on the Supervisor.</li> <li>• 02 to 0F—When powering up, the system automatically boots from a default Cisco IOS software image stored on a TFTP server in the network. For this setting, configure and enable the Network Management Ethernet port on the Supervisor. The port must be operational. This setting also enables boot system commands which can override the default filename.</li> </ul>
06	0x0040	Causes system software to ignore the contents of the NVRAM configuration file.
07	0x0080	Enables the original equipment manufacturer (OEM) bit.
08	0x0100	Disables the Break function after 30 seconds.
09	0x0200	Not used.

Bit No.	Hex Value	Meaning/Function
10	0x0400	Specifies that broadcast packets are based on the 0.0.0.0 IP address.
11 and 12	0x0800 to 0x1000	Defines the console baud rate (the default value is 9600 baud).
13	0x2000	Boots an image from the boot flash memory.
14	0x4000	Specifies that the broadcast packets must use the subnet broadcast address.
15	0x8000	Enables diagnostic messages and ignores the contents of the NVRAM configuration file.

For example, to configure the router to boot to the ROM monitor prompt, set the configuration register to **0x2100** with the following commands:

**Example:**

```
Router# config t
Router(config)# config-register 0x2100
Router(config)#
```

**Tip** The typical bitmask for normal use is 0x2102. It specifies that the router must load the Cisco IOS software from the flash memory and boot to the Cisco IOS CLI prompt. The Break key is enabled only for 30 seconds. Hence, if required, you can break to the ROM monitor prompt.

**Step 2** Exit the global configuration mode.

**Example:**

```
Router(config)# exit
Router#
```

**Step 3** View the new software configuration register setting using the **show version** command.

The last line shows the settings of the configuration register:

**Example:**

```
Router# show version
Cisco IOS XE Software, Version 15.5(20150302:044048) [v155_2_s_xe315_throttle-xxxxx-XE315_0301 121]
Cisco IOS Software, IOS-XE Software (X86_64_LINUX_IOSD-UNIVERSALK9-M), Experimental \
This software is an Engineering Special
Copyright (c) 1986-2015 by Cisco Systems, Inc.
Compiled Wed 04-Mar-15 00:21 by xxxxx
```

```
Cisco IOS-XE software, Copyright (c) 2005-2015 by cisco Systems, Inc.
All rights reserved. Certain components of Cisco IOS-XE software are
licensed under the GNU General Public License ("GPL") Version 2.0. The
software code licensed under GPL Version 2.0 is free software that comes
with ABSOLUTELY NO WARRANTY. You can redistribute and/or modify such
GPL code under the terms of GPL Version 2.0. For more details, see the
documentation or "License Notice" file accompanying the IOS-XE software,
or the applicable URL provided on the flyer accompanying the IOS-XE
software.
```

```
ROM: IOS-XE ROMMON
```

```
Router uptime is 14 minutes
```

```
Uptime for this control processor is 17 minutes
System returned to ROM by SSO Switchover
System image file is "bootflash:cbrsup-universalk9.2015-03-04_00.38_xxxxx.SSA.bin"
Last reload reason: Reload Command
```

This product contains cryptographic features and is subject to United States and local country laws governing import, export, transfer and use. Delivery of Cisco cryptographic products does not imply third-party authority to import, export, distribute or use encryption. Importers, exporters, distributors and users are responsible for compliance with U.S. and local country laws. By using this product you agree to comply with applicable laws and regulations. If you are unable to comply with U.S. and local laws, return this product immediately.

A summary of U.S. laws governing Cisco cryptographic products may be found at: <http://www.cisco.com/wvl/export/crypto/tool/stqrg.html>

If you require further assistance please contact us by sending email to [export@cisco.com](mailto:export@cisco.com).

```
cisco cBR1013 (CBR) processor (revision CBR) with 3647635K/6147K bytes of memory.
Processor board ID CSJ13152101
16 Gigabit Ethernet interfaces
32768K bytes of non-volatile configuration memory.
50331648K bytes of physical memory.
7739391K bytes of eUSB flash at bootflash:.
97620247K bytes of SATA hard disk at harddisk:.
979258K bytes of USB flash at usb1:.
```

Configuration register is 0x2

When you modify the configuration register, the **show version** command shows both the current value of the register and the value that will be used during the next reboot or reload.

**Step 4** Perform one of the following to save the new software configuration register settings in the configuration file:

- Use the **copy running-config startup-config** command.
- Use the **write** command.

**Example:**

```
Router# copy running-config startup-config
```

```
Router# write
Building configuration...
[OK]
```

**Step 5** The changes to the software configuration register will take effect the next time the router is rebooted or restarted. To manually reboot the router, use the **reload** command:

**Example:**

```
Router# reload
System configuration has been modified. Save? [yes/no]: yes
Proceed with reload? [confirm]
```



## Saving a Configuration File to the Bootflash or Hard Disk

This section describes how to copy a configuration file to a bootflash or hard disk and configure the Cisco cBR router.

**Step 1** Copy the configuration file to the bootflash or hard disks in both Supervisors.

**Example:**

```
Router# copy running-config bootflash:cbr8-config
Router# copy running-config stby-bootflash:cbr8-config
Router# copy running-config harddisk:cbr8-config
Router# copy running-config stby-harddisk:cbr8-config
```

**Step 2** (Optional) If the configuration file is currently on a TFTP server, copy the file from the TFTP server to the bootflash or hard disk in each Supervisor.

**Example:**

```
Router# copy tftp://192.168.100.10/router-config bootflash:cbr8-config
Router# copy tftp://192.168.100.10/router-config stby-bootflash:cbr8-config
Router# copy tftp://192.168.100.10/router-config harddisk:cbr8-config
Router# copy tftp://192.168.100.10/router-config stby-harddisk:cbr8-config
```

## Verifying the Supervisor Redundancy Configuration

This section contains the following topics:

### Verifying Supervisor Redundancy

**Step 1** View the startup configuration and verify whether the lines for configuring redundancy appear:

**Example:**

```
Router# show startup-config

...
redundancy
mode sso
...
```

**Step 2** View the current Supervisor redundancy state by running the **show redundancy** command. The active Supervisor is typically shown in slot 4 (SUP0).

```
Router# show redundancy

Redundant System Information :
-----
Available system uptime = 28 minutes
Switchovers system experienced = 0
Standby failures = 0
```

```

Last switchover reason = none

Hardware Mode = Duplex
Configured Redundancy Mode = sso
Operating Redundancy Mode = sso
Maintenance Mode = Disabled
Communications = Up

Current Processor Information :
-----
Active Location = slot 4
Current Software state = ACTIVE
Uptime in current state = 28 minutes
Image Version = Cisco IOS Software, IOS-XE Software (X86_64_LINUX_IOSD-UNIVERSALK9-M), Experimental
  Version 15.5(20150302:044048) [v155_2_s_xe315_throttle-xxxxx-XE315_0301 121]
This software is an Engineering Special
Copyright (c) 1986-2015 by Cisco Systems, Inc.
Compiled Wed 04-Mar-15 00:21 by xxxxx
BOOT = bootflash:cbrsup-universalk9.2015-03-04_00.38_xxxxx.SSA.bin,12;
CONFIG_FILE = bootflash:startup_config1419513118
Configuration register = 0x2

Peer Processor Information :
-----
Standby Location = slot 5
Current Software state = STANDBY HOT
Uptime in current state = 24 minutes
Image Version = Cisco IOS Software, IOS-XE Software (X86_64_LINUX_IOSD-UNIVERSALK9-M), Experimental
  Version 15.5(20150302:044048) [v155_2_s_xe315_throttle-xxxxx-XE315_0301 121]
This software is an Engineering Special
Copyright (c) 1986-2015 by Cisco Systems, Inc.
Compiled Wed 04-Mar-15 00:21 by xxxxx
BOOT = bootflash:cbrsup-universalk9.2015-03-04_00.38_xxxxx.SSA.bin,12;
CONFIG_FILE = bootflash:startup_config1419513118
Configuration register = 0x2

```

If a switchover occurs, the **show redundancy** command shows that the active Supervisor has changed slots, moving from slot 4 (SUP0) to slot 5 (SUP1). The output is similar to the one in the following example.

```

Router# show redundancy

Redundant System Information :
-----
Available system uptime = 39 minutes
Switchovers system experienced = 1
Standby failures = 0
Last switchover reason = user forced

Hardware Mode = Duplex
Configured Redundancy Mode = sso
Operating Redundancy Mode = sso
Maintenance Mode = Disabled
Communications = Up

Current Processor Information :
-----
Active Location = slot 5
Current Software state = ACTIVE
Uptime in current state = 10 minutes
Image Version = Cisco IOS Software, IOS-XE Software (X86_64_LINUX_IOSD-UNIVERSALK9-M), Experimental
  Version 15.5(20150302:044048) [v155_2_s_xe315_throttle-xxxxx-XE315_0301 121]
This software is an Engineering Special
Copyright (c) 1986-2015 by Cisco Systems, Inc.

```

```

Compiled Wed 04-Mar-15 00:21 by xxxxx
BOOT = bootflash:cbrsup-universalk9.2015-03-04_00.38_xxxxx.SSA.bin,12;
CONFIG_FILE = bootflash:startup_config1419513118
Configuration register = 0x2

Peer Processor Information :
-----
Standby Location = slot 4
Current Software state = STANDBY HOT
Uptime in current state = 4 minutes
Image Version = Cisco IOS Software, IOS-XE Software (X86_64_LINUX_IOSD-UNIVERSALK9-M), Experimental
Version 15.5(20150302:044048) [v155_2_s_xe315_throttle-xxxxx-XE315_0301 121]
This software is an Engineering Special
Copyright (c) 1986-2015 by Cisco Systems, Inc.
Compiled Wed 04-Mar-15 00:21 by xxxxx
BOOT = bootflash:cbrsup-universalk9.2015-03-04_00.38_xxxxx.SSA.bin,12;
CONFIG_FILE = bootflash:startup_config1419513118
Configuration register = 0x2

```

If the standby Supervisor is not installed or is not operational, the **show redundancy** command gives an output similar to the following example:

```

Router# show redundancy

Redundant System Information :
-----
Available system uptime = 31 minutes
Switchovers system experienced = 1
Standby failures = 0
Last switchover reason = user forced

Hardware Mode = Simplex
Configured Redundancy Mode = sso
Operating Redundancy Mode = Non-redundant
Maintenance Mode = Disabled
Communications = Down Reason: Failure

Current Processor Information :
-----
Active Location = slot 5
Current Software state = ACTIVE
Uptime in current state = 2 minutes
Image Version = Cisco IOS Software, IOS-XE Software (X86_64_LINUX_IOSD-UNIVERSALK9-M), Experimental
Version 15.5(20150302:044048) [v155_2_s_xe315_throttle-xxxxx-XE315_0301 121]
This software is an Engineering Special
Copyright (c) 1986-2015 by Cisco Systems, Inc.
Compiled Wed 04-Mar-15 00:21 by xxxxx
BOOT = bootflash:cbrsup-universalk9.2015-03-04_00.38_xxxxx.SSA.bin,12;
CONFIG_FILE = bootflash:startup_config1419513118
Configuration register = 0x2

Peer (slot: 4) information is not available because it is in 'DISABLED' state

```

The **show redundancy** command shows details of the redundancy state, software state, system uptime, image version, boot, configuration file, and configuration register information.

After supervisor redundancy, the following messages are displayed, for example:

```

CLC 3/0: May 20 07:26:01.992: %CBR-4-RECONCL_CM_FINISH_CLC: Reconciliation (cdm->ios) for slot 3
finished: total 7, success 5, failed 2, ios-only 2, cdm-only 0, mismatch 0, offline 0,
in-transaction-reconl 0, in-transaction-recover 0.

```

Where:

**total** indicates the overall number of cable modems on each linecard before failover.

**success** indicates the number of modems, which are remained online during failover.

**failed** indicates the number of cable modems which have failed reconciliation check, and deleted from database.

**ios-only** indicates the number of cable modems which has data entry in linecard iosd only, and have been deleted from database.

**cdm-only** indicates the number of cable modems which has data entry in linecard cdman (us-scheduler) only, and have been deleted from database.

**mismatch** indicates the number of cable modems which with data mismatch in the modem instance or service-flows after failover. These modems have been deleted from database.

**offline** indicates the number of cable modems which are dropped offline during failover.

**in-transaction-reconl** indicates the number of cable modems that are deleted due to in dsx operations during failover.

**in-transaction-recover** indicates the number of cable modems during in dsx operations during failover.

## Verifying Supervisor Switchover

**Step 1** Verify the LEDs on the Supervisor Card.

When a Supervisor becomes active, the RP ACT and FP ACT LEDs on the Supervisor Card illuminate green to indicate that they have initialized and acting as the active Supervisor. The RP ACT and FP ACT on standby Supervisor Card are off. For more information, see [Monitoring the Supervisor in the Cisco cBR Chassis](#).

**Step 2** Verify the Supervisor switchover by running the **show redundancy switchover history** command.

If the original Supervisor is in slot 4 (SUP0) and the standby Supervisor is in slot 5 (SUP1), the output is similar to the following sample:

**Example:**

```
Router# show redundancy switchover history
```

Index	Previous active	Current active	Switchover reason	Switchover time
1	48	49	user forced	19:23:11 CST Sun Jan 1 2012

The value 48 indicates SUP0 and 49 indicates SUP1.

After supervisor redundancy, a messages is displayed, below is an example:

```
CLC 3/0: May 20 07:26:01.992: %CBR-4-RECONCL_CM_FINISH_CLC: Reconciliation (cdm->ios) for slot 3 finished: total 7, success 5, failed 2, ios-only 2, cdm-only 0, mismatch 0, offline 0, in-transaction-reconl 0, in-transaction-recover 0.
```

Table 29: Message Description

Name	Description
total	Overall amount of cable modems on each linecard before failover.
success	Indicates the number of cable modems remain online during failover.
failed	Indicates the number of cable modems failed reconciliation check, and have been deleted from database.
ios-only	Indicates the number of cable modems which has data entry in linecard iosd only, and have been deleted from database.
cdm-only	Indicates the number of cable modems which has data entry in linecard cdman (us-scheduler) only, and have been deleted from database.
mismatch	Indicates the number of cable modems with data mismatch in the modem instance or service-flows after failover. These modems have been deleted from database.
offline	Indicates the number of cable modems dropped offline during failover.
in-transaction-reconl	Indicates the number of cable modems deleted due to in dsx operations during failover.
in-transaction-recove	Indicates the number of cable modems during in dsx operations during failover.

## Configuration Example for Supervisor Redundancy

The following example shows the relevant portion of the Cisco IOS configuration file for the default configuration of the Supervisor Redundancy feature. Use this configuration for most of the applications:

```
Router# show running-config | sec redundancy

redundancy
 mode sso

Router#
```

## Additional References

### Related Documents

Related Topic	Document Title
CMTS commands	<a href="#">Cisco IOS CMTS Cable Command Reference</a>
Stateful Switchover	<a href="#">Stateful Switchover</a>

### Technical Assistance

Description	Link
<p>The Cisco Support website provides extensive online resources, including documentation and tools for troubleshooting and resolving technical issues with Cisco products and technologies.</p> <p>To receive security and technical information about your products, you can subscribe to various services, such as the Product Alert Tool (accessed from Field Notices), the Cisco Technical Services Newsletter, and Really Simple Syndication (RSS) Feeds.</p> <p>Access to most tools on the Cisco Support website requires a Cisco.com user ID and password.</p>	<a href="http://www.cisco.com/support">http://www.cisco.com/support</a>

## Feature Information for Supervisor Redundancy

Use Cisco Feature Navigator to find information about the platform support and software image support. Cisco Feature Navigator enables you to determine which software images support a specific software release, feature set, or platform. To access Cisco Feature Navigator, go to the <https://cfnng.cisco.com/> link. An account on the Cisco.com page is not required.



**Note** The following table lists the software release in which a given feature is introduced. Unless noted otherwise, subsequent releases of that software release train also support that feature.

*Table 30: Feature Information for Supervisor Redundancy*

Feature Name	Releases	Feature Information
Supervisor Redundancy	Cisco IOS XE Fuji 16.7.1	This feature was integrated on Cisco cBR Series Converged Broadband Routers.



## CHAPTER 11

# Line Card Redundancy

The line cards support high availability with redundancy schemes. Line card redundancy can help limit customer premises equipment (CPE) downtime by enabling robust automatic switchover and recovery in the event that there is a localized system failure.

Your software release may not support all the features that are documented in this module. For the latest feature information and caveats, see the release notes for your platform and software release. The Feature Information Table at the end of this document provides information about the documented features and lists the releases in which each feature is supported.

Use Cisco Feature Navigator to find information about platform support and Cisco software image support. To access Cisco Feature Navigator, go to <http://tools.cisco.com/ITDIT/CFN/>. An account on <http://www.cisco.com/> is not required.

### Contents

- [Hardware Compatibility Matrix for the Cisco cBR Series Routers, on page 179](#)
- [Prerequisites for Line Card Redundancy, on page 181](#)
- [Restrictions for Line Card Redundancy, on page 181](#)
- [Information About Line Card Redundancy, on page 182](#)
- [How to Configure Line Card Redundancy, on page 182](#)
- [Verifying the Line Card Redundancy Configuration, on page 184](#)
- [Enabling LCHA When DPIC Fails, on page 188](#)
- [Additional References, on page 190](#)
- [Feature Information for Line Card Redundancy, on page 191](#)

## Hardware Compatibility Matrix for the Cisco cBR Series Routers



---

**Note** The hardware components that are introduced in a given Cisco IOS-XE Release are supported in all subsequent releases unless otherwise specified.

---

Table 31: Hardware Compatibility Matrix for the Cisco cBR Series Routers

Cisco CMTS Platform	Processor Engine	Interface Cards
Cisco cBR-8 Converged Broadband Router	<p><b>Cisco IOS-XE Release 16.5.1 and Later Releases</b></p> <p>Cisco cBR-8 Supervisor:</p> <ul style="list-style-type: none"> <li>• PID—CBR-SUP-250G</li> <li>• PID—CBR-CCAP-SUP-160G</li> </ul>	<p><b>Cisco IOS-XE Release 16.5.1 and Later Releases</b></p> <p>Cisco cBR-8 CCAP Line Cards:</p> <ul style="list-style-type: none"> <li>• PID—CBR-LC-8D30-16U30</li> <li>• PID—CBR-LC-8D31-16U30</li> <li>• PID—CBR-RF-PIC</li> <li>• PID—CBR-RF-PROT-PIC</li> <li>• PID—CBR-CCAP-LC-40G</li> <li>• PID—CBR-CCAP-LC-40G-R</li> <li>• PID—CBR-CCAP-LC-G2-R</li> <li>• PID—CBR-SUP-8X10G-PIC</li> <li>• PID—CBR-2X100G-PIC</li> </ul> <p>Digital PICs:</p> <ul style="list-style-type: none"> <li>• PID—CBR-DPIC-8X10G</li> <li>• PID—CBR-DPIC-2X100G</li> </ul> <p>Cisco cBR-8 Downstream PHY Module:</p> <ul style="list-style-type: none"> <li>• PID—CBR-D31-DS-MOD</li> </ul> <p>Cisco cBR-8 Upstream PHY Modules:</p> <ul style="list-style-type: none"> <li>• PID—CBR-D31-US-MOD</li> </ul>



**Note** Do not use DPICs (8X10G and 2x100G) to forward IP traffic, as it may cause buffer exhaustion, leading to line card reload.

The only allowed traffic on a DPIC interface is DEPI, UEPI, and GCP traffic from the Cisco cBR-8 router to Remote PHY devices. Other traffic such as DHCP, SSH, and UTSC should flow via another router, since DPICs cannot be used for normal routing.



## Prerequisites for Line Card Redundancy

- At least one RF Through PIC and its corresponding interface line card must be installed in the chassis to be configured as the primary card.
- An RF Protect PIC and its corresponding interface line card must be installed in the chassis to be configured as the secondary card.

## Restrictions for Line Card Redundancy

- For Supervisor 160G, the line cards installed in slot 3 and 6 of the Cisco cBR-8 router cannot be configured as the secondary card. The limitation does not apply for Supervisor 250G.
- The RF Protect PIC can send RF signals only to the lower slots (with larger slot number). So, the slot number of the secondary card must be the smallest in the redundancy group.



---

**Note** We recommend that you install the RF Protect PIC in the uppermost slot (slot 0) of the chassis and configure it as the secondary card.

---

- The RF Through PIC can send RF signal only from upper slot to lower slot. So, do not install any RF blank PICs between the secondary card and primary cards.
- You cannot change any configuration on the primary or secondary card when the secondary card is active.
- You cannot remove the last primary card if there is a secondary card in the redundancy group. You must remove the secondary card and then remove the primary card.
- If the primary card is in the standby role, you must revert to the primary card before removing it from the redundancy group.
- For CBR-CCAP-LC-40G high availability domain, ensure that all CBR-CCAP-LC-40G Line Cards are in continuous slots and using the lowest slot number as secondary Line Card. The limitation does not apply for CBR-CCAP-LC-40G-R or CBR-CCAP-LC-G2-R Line Cards.
- CBR-CCAP-LC-G2-R provides protection only to CBR-CCAP-LC-G2-R.



---

**Note**

- From Cisco IOS XE Bengaluru 17.6.1, CBR-CCAP-LC-G2-R and CBR-CCAP-LC-40G-R line cards must not be part of the same redundancy group.
- In Cisco IOS XE Amsterdam 17.3.1 and earlier releases, CBR-CCAP-LC-G2-R provides protection to CBR-CCAP-LC-G2-R or CBR-CCAP-LC-40G-R.
- Protection for CBR-CCAP-LC-G2-R by CBR-CCAP-LC-40G-R is not supported.

---

# Information About Line Card Redundancy

Line card redundancy reduces the unplanned downtime. When you configure line card redundancy, a protect zone (redundancy group) is created on the router and the configurations on the primary cards are synchronized with the secondary card.

The following events can trigger a switchover from an active card to a standby card:

- Manual switchover using the **redundancy linecard-group switchover from slot slot** command.
- Line card reload using the **hw-module slot reload** command.
- Line card crash.
- Line card Online Insertion and Removal (OIR).

The secondary card reloads after the switchover. The router can be configured to automatically revert to the primary card when it becomes hot standby after an unplanned switchover triggered by the line card OIR or crash.

Following are the line card redundancy states:

- **Unavail**—The line card state is not available.
- **Init**—The line card did not boot up.
- **Active Cold**—The active card is downloading the configuration.
- **Active**—The active card is fully configured and working.
- **Stdb Cold**—The standby card configuration is synchronizing with the active card.
- **Stdb Warm**—(Only for the secondary card) The standby card is fully synchronized and ready for switchover. It is the stable state of a secondary standby card.
- **Stdb Hot**—The primary standby card is fully synchronized. It is the stable state of a primary standby card. The secondary standby card is chosen to switchover for a primary card, and will be active soon. It is a transient state when secondary card is becoming active.

## N+1 Line Card Redundancy

The Cisco cBR-8 router supports N+1 redundancy scheme for line cards. A single RF Protect PIC can be configured as a secondary card for multiple RF Through PICs (primary cards). In this redundancy scheme, when the secondary card becomes the active card for a primary card, the redundancy scheme is changed to 1+1 redundancy.

The Cisco cBR-8 router supports a single protect zone or redundancy group (group 0).

# How to Configure Line Card Redundancy

This section contains the following:

## Configuring Line Card Manual Switchover

### Before you begin

The line card must be in active role, and warm standby or hot standby state. Use the **show redundancy linecard all** command to verify the role and state of the card.

### Restrictions

- You cannot perform a manual switchover when the standby Supervisor is booting up and not yet entered into SSO.
- You cannot auto revert the switchover triggered manually.

### Procedure

	Command or Action	Purpose
Step 1	<b>enable</b> <b>Example:</b> Router> <b>enable</b>	Enables privileged EXEC mode. <ul style="list-style-type: none"> <li>• Enter your password if prompted.</li> </ul>
Step 2	<b>redundancy linecard-group switchover from slot slot</b> <b>Example:</b> Router# <b>redundancy linecard-group switchover from slot 9</b>	Manually switches over from the active line card.

## Configuring N+1 Line Card Redundancy

### Procedure

	Command or Action	Purpose
Step 1	<b>enable</b> <b>Example:</b> Router> <b>enable</b>	Enables privileged EXEC mode. <ul style="list-style-type: none"> <li>• Enter your password if prompted.</li> </ul>
Step 2	<b>configure terminal</b> <b>Example:</b> Router# <b>configure terminal</b>	Enters global configuration mode.
Step 3	<b>redundancy</b> <b>Example:</b> Router(config)# <b>redundancy</b>	Enables redundancy and enters redundancy configuration mode.
Step 4	<b>linecard-group group-id internal-switch</b> <b>Example:</b>	Configures the redundancy group and enters the line card redundancy configuration mode.

	Command or Action	Purpose
	<code>Router(config-red)# linecard-group 0 internal-switch</code>	
<b>Step 5</b>	<b>description</b> <i>group-description</i> <b>Example:</b> <code>Router(config-red-lc)# description RedundancyGroup0</code>	(Optional) Configures the redundancy group description.
<b>Step 6</b>	<b>class</b> 1:N <b>Example:</b> <code>Router(config-red-lc)# class 1:N</code>	Configures the N+1 redundancy class for the redundancy group.
<b>Step 7</b>	<b>revertive</b> <i>seconds</i> <b>Example:</b> <code>Router(config-red-lc)# revertive 60</code>	(Optional) Configures the auto revert time for the primary card, in seconds.
<b>Step 8</b>	<b>member slot</b> <i>slot primary</i> <b>Example:</b> <code>Router(config-red-lc)# member slot 1 primary</code>	Adds the line card as a primary card in the redundancy group. <b>Note</b> Repeat this step for each primary card to be added in the redundancy group.
<b>Step 9</b>	<b>member slot</b> <i>slot secondary</i> <b>Example:</b> <code>Router(config-red-lc)# member slot 0 secondary</code>	Adds the line card as a primary card in the redundancy group.
<b>Step 10</b>	<b>end</b> <b>Example:</b> <code>Router(config-red-lc)# end</code>	Returns to privileged EXEC mode.

## Verifying the Line Card Redundancy Configuration

- **show redundancy linecard group all**—Displays the redundancy group information.

The following is a sample output of this command:

```
Router# show redundancy linecard group all

Group Identifier: 0
Revertive, Revert Timer: OFF (60000 sec)
Reserved Cardtype: 0xFFFFFFFF 4294967295
Group Redundancy Type: INTERNAL SWITCH
Group Redundancy Class: 1:N
Group Redundancy Configuration Type: LINECARD GROUP
Primary: Slot 6
Primary: Slot 7
Secondary: Slot 0
```

- **show redundancy linecard all**—Displays the role and state information for all line cards.

Following is a sample output of this command:

```
Router# show redundancy linecard all
```

Slot	Subslot	LC Group	My State	Peer State	Peer Slot	Peer Subslot	Role	Mode
9	-	0	Active	Stdby Cold	0	-	Active	Primary
8	-	0	Active	Stdby Warm	0	-	Active	Primary
7	-	0	Active	Stdby Warm	0	-	Active	Primary
6	-	0	Active	Stdby Cold	0	-	Active	Primary
3	-	0	Active	Stdby Cold	0	-	Active	Primary
2	-	0	Active	Stdby Cold	0	-	Active	Primary
1	-	0	Active	Stdby Cold	0	-	Active	Primary
0	-	0	-	-	Multiple	None	Standby	Secondary



**Note** The secondary card does not have a valid *My State* when it is in *Standby* role as it is the peer for *N* primary cards. The secondary card has *N* peer states. For example, it can be cold standby for some primary cards and warm standby for the other primary card.

Following is a sample output of the command when secondary card becomes active for a primary card, and the N+1 redundancy is changed to 1+1 redundancy:

```
Router# show redundancy linecard all
```

Slot	Subslot	LC Group	My State	Peer State	Peer Slot	Peer Subslot	Role	Mode
9	-	0	Stdby Hot	Active	0	-	Standby	Primary
8	-	0	Active	Unavail	0	-	Active	Primary
7	-	0	Active	Unavail	0	-	Active	Primary
6	-	0	Active	Unavail	0	-	Active	Primary
3	-	0	Active	Unavail	0	-	Active	Primary
2	-	0	Active	Unavail	0	-	Active	Primary
1	-	0	Active	Unavail	0	-	Active	Primary
0	-	0	Active	Stdby Hot	9	-	Active	Secondary

- **show redundancy linecard slot**—Displays the redundancy information for the line card.

Following is a sample output of the command:

```
Router# show redundancy linecard slot 9
```

```
LC Redundancy Is Configured:
LC Group Number: 0
LC Slot: 9 (idx=9)
LC Peer Slot: 0
LC Card Type: 0x4076 , 16502
LC Name: 9
LC Mode: Primary
LC Role: Active
LC My State: Active
LC Peer State: Stdby Warm
```

- **show redundancy linecard history**—Displays the state change history for all line cards.

Following is a sample output of the command:

```
Router# show redundancy linecard history
```

```
Jan 05 2012 12:24:27 20559 - st_mem(9): MY State Change, (Active Wait) -> (Active)
Jan 05 2012 12:24:27 20559 - st_mem(9): MY FSM execution, Active Wait:Init:State Ntfy
Jan 05 2012 12:24:27 20559 - st_mem(9): MY State Change, (Active LC Cfg Dnld) -> (Active
  Wait)
Jan 05 2012 12:24:27 20559 - st_mem(9): MY FSM execution, Active LC Cfg Dnld:Init:Cfg
  Dnld Done
Jan 05 2012 12:24:27 20559 - st_mem(9): MY State Change, (Active Cold) -> (Active LC
  Cfg Dnld)
Jan 05 2012 12:23:09 12763 - st_mem(9): MY FSM execution, Active Cold:Init:Cfg Dnld
Jan 05 2012 12:23:09 12760 - st_mem(9): MY State Change, (Init) -> (Active Cold)
Jan 05 2012 12:23:09 12760 - st_mem(9): MY FSM execution, Init:Init:Up
Jan 05 2012 12:21:39 3746 - st_mem(9): PEER FSM Execution , Init:Init:Reset
```

- **show lcha rfsw**—Displays the internal RF switch PIC state information.

Following is a sample output of the command:

```
Router# show lcha rfsw

Slot 0 =====
Type : Secondary PIC State: normal
Slot 1 =====
Type : Primary PIC State: normal
```

- **show lcha logging level**—Displays the cable modem line card logs.

Following is a sample output of the command:

```
Router# show lcha logging level noise

11:02:03.313 CST Tue Nov 18 2014 [error] [slot=3] [txn=229] Peer-Up Message [tag=1011]
  to slot 3 complete [36144 ms]; status=nak response
11:02:03.313 CST Tue Nov 18 2014 [error] [slot=0] [txn=229] Slot 0 downloaded
  configuration for slot 3; result=peer-up notification failed
11:02:03.316 CST Tue Nov 18 2014 [noise] [slot=0] [txn=none]
  lcha_plfm_get_max_port_count_for_slot: slot 0 maximum port count is 1794
11:02:03.316 CST Tue Nov 18 2014 [noise] [slot=0] [txn=none]
  lcha_plfm_get_starting_port_index: slot 0 starting port count is 0
11:02:03.331 CST Tue Nov 18 2014 [note] [slot=0] [txn=none] Slot 0 is being reset
11:02:04.352 CST Tue Nov 18 2014 [note] [slot=0] [txn=none] slot 0 removed
```

- When the secondary card is active, you can use the slot number of either the primary or secondary card in the **show** commands.

Following is a sample output of the **show interfaces** command after the primary card in slot 8 switches over to secondary card in slot 0:

```
Router# show interfaces c0/0/0

Cable0/0/0 is up, line protocol is up
  Hardware is CMTS MD interface, address is 0000.0000.031e (bia 0000.0000.031e)
  MTU 1500 bytes, BW 26000 Kbit/sec, DLY 1000 usec,
    reliability 255/255, txload 1/255, rxload 1/255
  Encapsulation MCNS, loopback not set
  Keepalive set (10 sec)
  ARP type: ARPA, ARP Timeout 04:00:00
  Last input never, output never, output hang never
  Last clearing of "show interface" counters never
  Input queue: 0/375/0/0 (size/max/drops/flushes); Total output drops: 0
  Queueing strategy: weighted fair
```

```

Output queue: 0/1000/64/0 (size/max total/threshold/drops)
  Conversations 0/0/256 (active/max active/max total)
  Reserved Conversations 0/0 (allocated/max allocated)
  Available Bandwidth 19500 kilobits/sec
5 minute input rate 0 bits/sec, 0 packets/sec
5 minute output rate 13000 bits/sec, 17 packets/sec
  0 packets input, 0 bytes, 0 no buffer
  Received 0 broadcasts (0 multicasts)
  0 runts, 0 giants, 0 throttles
  0 input errors, 0 CRC, 0 frame, 0 overrun, 0 ignored, 0 abort
140520 packets output, 14052672 bytes, 0 underruns
  0 output errors, 0 collisions, 1 interface resets
  0 unknown protocol drops
  0 output buffer failures, 0 output buffers swapped out

```

```
Router# show interfaces c8/0/0
```

```

Cable0/0/0 is up, line protocol is up
  Hardware is CMTS MD interface, address is 0000.0000.031e (bia 0000.0000.031e)
  MTU 1500 bytes, BW 26000 Kbit/sec, DLY 1000 usec,
    reliability 255/255, txload 1/255, rxload 1/255
  Encapsulation MCNS, loopback not set
  Keepalive set (10 sec)
  ARP type: ARPA, ARP Timeout 04:00:00
  Last input never, output never, output hang never
  Last clearing of "show interface" counters never
  Input queue: 0/375/0/0 (size/max/drops/flushes); Total output drops: 0
  Queueing strategy: weighted fair
Output queue: 0/1000/64/0 (size/max total/threshold/drops)
  Conversations 0/0/256 (active/max active/max total)
  Reserved Conversations 0/0 (allocated/max allocated)
  Available Bandwidth 19500 kilobits/sec
5 minute input rate 0 bits/sec, 0 packets/sec
5 minute output rate 14000 bits/sec, 18 packets/sec
  0 packets input, 0 bytes, 0 no buffer
  Received 0 broadcasts (0 multicasts)
  0 runts, 0 giants, 0 throttles
  0 input errors, 0 CRC, 0 frame, 0 overrun, 0 ignored, 0 abort
140616 packets output, 14062272 bytes, 0 underruns
  0 output errors, 0 collisions, 1 interface resets
  0 unknown protocol drops
  0 output buffer failures, 0 output buffers swapped out

```

- When the secondary card is active, the **show running-config** command displays the output for the secondary card.



---

**Note** The output of the **show running-config** command is empty for the primary card when the secondary card is active.

---

Following is a sample output of the **show running-config** command after the primary card in slot 8 switches over to secondary card in slot 0:

```

Router# show running-config | begin controller Upstream-Cable 0

controller Upstream-Cable 0/0/0
  us-channel 0 channel-width 1600000 1600000
  us-channel 0 docsis-mode atdma
  us-channel 0 minislot-size 4
  us-channel 0 modulation-profile 221

```

```

no us-channel 0 shutdown
us-channel 1 channel-width 1600000 1600000
us-channel 1 docsis-mode atdma

Router# show running-config | begin controller Upstream-Cable 8
Router#
Router#

```

## Enabling LCHA When DPIC Fails

Table 32: Feature History

Feature Name	Release Information	Feature Description
Enabling Line Card Redundancy When DPIC Fails	Cisco IOS XE Dublin 17.12.1x	<p>In this release, Line Card Redundancy (LCHA) triggers when Digital Physical Interface Cards (DPIC) encounters a hardware failure. This action ensures that the service is not impacted when a DPIC has a Hardware failure. This feature supports the <b>CBR-DPIC-8X10G</b> and <b>CBR-DPIC-2X100G</b> Interface Cards.</p> <p>In previous releases, when a DPIC encounters a hardware failure, the DPIC state moves to <b>out of service</b> and LCHA cannot be triggered. Triggering of LCHA was based on the state of the line card.</p>

This feature follows the LCHA configuration. The following table shows the actions that are performed based as per the following conditions:

Table 33: LCHA Trigger Conditions

Condition	Action
The DPIC which has a Hardware failure is not in the LCHA group	No Action
The DPIC which has a Hardware failure is on standby	No Action
The DPIC which has a Hardware failure is active and the standby line card is ready to do LCHA	LCHA is triggered
The DPIC which has a Hardware failure is active, and the secondary line card is protecting another line card	Cisco IOS waits for the Secondary line card to move into the standby role, and then trigger LCHA.



When a DPIC fails, Cisco IOS resets the DPIC 5 times to confirm it has failed to boot. Post this process, the DPIC state is moved to **out of service** and decides if it is possible to trigger LCHA. During this time period, the DPIC goes offline for approximately 5–10 mins.

In the example log below, **DPIC 8/1** encounters a hardware failure.

```
Nov 17 14:37:37.045 CST: %SPA_OIR-3-SPA_POWERED_OFF: subslot 8/1: SPA Digital PIC powered
off after 5 failures within 1200 seconds
Nov 17 14:37:37.046 CST: %SPA_OIR-6-OFFLINECARD: SPA (CBR-DPIC-8X10G) offline in subslot
8/1
Nov 17 14:37:37.026 CST: %CBR_SPA-3-DPIC_BOOT_REASON: C4/8: iomd: DPIC 8/1: DPIC cannot
boot due to "CPU PowerOn Reset"(value: 1, should be 1)
Nov 17 14:37:37.027 CST: %CBR_SPA-3-DPIC_BOOT_REASON: C4/8: iomd: DPIC 8/1: DPIC cannot
boot due to "HA PLL Reset"(value: 1, should be 1)
Nov 17 14:37:37.029 CST: %CBR_SPA-3-DPIC_BOOT_REASON: C4/8: iomd: DPIC 8/1: DPIC cannot
boot due to "HA PLL Lock"(value: 1, should be 1)
Nov 17 14:37:37.029 CST: %CBR_SPA-3-DPIC_BOOT_REASON: C4/8: iomd: DPIC 8/1: DPIC cannot
boot due to "Local PLL Reset"(value: 1, should be 1)
Nov 17 14:37:37.030 CST: %CBR_SPA-3-DPIC_BOOT_REASON: C4/8: iomd: DPIC 8/1: DPIC cannot
boot due to "Local PLL Lock"(value: 1, should be 1)
Nov 17 14:37:37.031 CST: %CBR_SPA-3-DPIC_BOOT_REASON: C4/8: iomd: DPIC 8/1: DPIC cannot
boot due to "Local PLL Lock2"(value: 1, should be 1)
Nov 17 14:37:37.038 CST: %CBR_SPA-3-DPIC_BOOT_REASON: C4/8: iomd: DPIC 8/1: DPIC cannot
boot due to "54v Input"(value: 0, should be 0)
Nov 17 14:37:37.039 CST: %CBR_SPA-3-DPIC_BOOT_REASON: C4/8: iomd: DPIC 8/1: DPIC cannot
boot due to "Ready"(value: 1, should be 1)
Nov 17 14:37:37.040 CST: %CBR_SPA-3-DPIC_BOOT_REASON: C4/8: iomd: DPIC 8/1: DPIC cannot
boot due to "Mechanical OK"(value: 1, should be 1)
Nov 17 14:37:37.042 CST: %CBR_SPA-3-DPIC_BOOT_REASON: C4/8: iomd: DPIC 8/1: DPIC cannot
boot due to "Power OK"(value: 1, should be 1)
Nov 17 14:37:37.043 CST: %CBR_SPA-3-DPIC_BOOT_REASON: C4/8: iomd: DPIC 8/1: DPIC cannot
boot due to "Luzon FPGA Init"(value: 1, should be 1)
Nov 17 14:37:37.044 CST: %CBR_SPA-3-DPIC_BOOT_REASON: C4/8: iomd: DPIC 8/1: DPIC cannot
boot due to "Luzon FPGA Load Done"(value: 1, should be 1)
Nov 17 14:38:59.699 CST: %CBR_SPA-5-DPIC_HW_FAIL: C4/8: iomd: DPIC 8/1 hit Hardware Failure!
Nov 17 14:39:59.442 CST: %CARD_STATE-3-DPIC_HW_FAIL: DPIC 8/1 hit Hardware Failure, reset
this LC to trigger lcha
Nov 17 14:40:05.507 CST: %IOSXE_OIR-6-OFFLINECARD: Card (cc) offline in slot 8
Nov 17 14:40:05.514 CST: %CABLE_CLC-5-LOGGER_LC_REMOVED: Carrier Card 8 removed
Nov 17 14:40:05.523 CST: %BIPC-6-SESSION_DOWN: IPCCL Session to CLC8 is DOWN
```

The line card **LC8** triggers LCHA and becomes a standby line card.

```
Router#show redundancy linecard all
```

```
Load for five secs: 61%/5%; one minute: 53%; five minutes: 52%
Time source is NTP, 15:00:52.040 CST Fri Nov 17 2023
```

Slot	Subslot	LC Group	My State	Peer State	Peer Slot	Peer Subslot	Role	Mode
1	-	0	Active	Unavail	0	-	Active	Primary
8	-	0	Stdby Hot	Active	0	-	Standby	Primary
2	-	0	Active	Unavail	0	-	Active	Primary
3	-	0	Active	Unavail	0	-	Active	Primary
0	-	0	Active	Stdby Hot	8	-	Active	Secondary
6	-	None	Active	-	None	None	Active	None
7	-	None	Active	-	None	None	Active	None

### Legacy LCHA

The following table shows the actions that are performed based on the conditions for LCHA:

Table 34: Legacy LCHA

Condition	Action
<b>LCHA:</b> Cisco IOS checks the standby line card's DPIC state, and if the DPIC has a Hardware failure	LCHA is not allowed.
<b>LCHA Revert Back:</b> Cisco IOS checks the revert back line card's DPIC state, and if the DPIC has a Hardware failure	LCHA revert back is not allowed.

**Note**

- This feature is enabled by default and does not require any configuration.
- This feature only supports the triggering of LCHA when DPIC has a Hardware failure.  
LCHA is not triggered for any other scenarios. For example:
  - Software configured dpic shutdown.
  - Physical remove of the dpic.
  - Other software problems which result in the DPIC's unexpected state.

## Additional References

### Related Documents

Related Topic	Document Title
CMTS commands	<a href="#">Cisco CMTS Cable Command Reference</a>

### Technical Assistance

Description	Link
<p>The Cisco Support website provides extensive online resources, including documentation and tools for troubleshooting and resolving technical issues with Cisco products and technologies.</p> <p>To receive security and technical information about your products, you can subscribe to various services, such as the Product Alert Tool (accessed from Field Notices), the Cisco Technical Services Newsletter, and Really Simple Syndication (RSS) Feeds.</p> <p>Access to most tools on the Cisco Support website requires a Cisco.com user ID and password.</p>	<a href="http://www.cisco.com/support">http://www.cisco.com/support</a>

## Feature Information for Line Card Redundancy

Use Cisco Feature Navigator to find information about the platform support and software image support. Cisco Feature Navigator enables you to determine which software images support a specific software release, feature set, or platform. To access Cisco Feature Navigator, go to the <https://cfng.cisco.com/> link. An account on the Cisco.com page is not required.



**Note** The following table lists the software release in which a given feature is introduced. Unless noted otherwise, subsequent releases of that software release train also support that feature.

*Table 35: Feature Information for Line Card Redundancy*

Feature Name	Releases	Feature Information
Line Card Redundancy	Cisco IOS XE Fuji 16.7.1	This feature was integrated on the Cisco cBR Series Converged Broadband Routers.





## PART **III**

# Support For DOCSIS 4.0

- [Registering DOCSIS 4.0 Modems as DOCSIS 3.1 Modems, on page 195](#)





## CHAPTER 12

# Registering DOCSIS 4.0 Modems as DOCSIS 3.1 Modems

- [Registering DOCSIS 4.0 Modems as DOCSIS 3.1 Modems, on page 195](#)

## Registering DOCSIS 4.0 Modems as DOCSIS 3.1 Modems

*Table 36: Feature History*

Feature Name	Release Information	Feature Description
Support for 4xOFDM channel bonding on cBR8 platform	Cisco IOS XE Dublin 17.12.1z	Starting with this release, DOCSIS 4.0 modems on cBR-8 routers may use four OFDM channels for channel bonding, operating at their highest capacity to enhance functionality.
Support for DOCSIS 4.0 Modems registering in D3.1 mode.	Cisco IOS XE Dublin 17.12.1x	In this release, cBR-8 routers now support the registration of DOCSIS 4.0 modems in D3.1 modes. In this mode it is capable of utilizing two OFDM channels, providing enhanced throughput as compared to SCQAM channel.

A D4.0 modem can register in D3.1 or D4.0 DOCSIS mode. It includes the DOCSIS version in the modem advertised D4.0 capability, registered in D3.1 mode on TLV in the Registration Request message that it sends to the CMTS. A CMTS can operate in D3.1 or D4.0 mode in a MAC Domain and advertises the mode in the DOCSIS version TLV in the MDD messages it sends.

Figure 18: Basic Registration and Management Support for DOCSIS 4.0 Modems

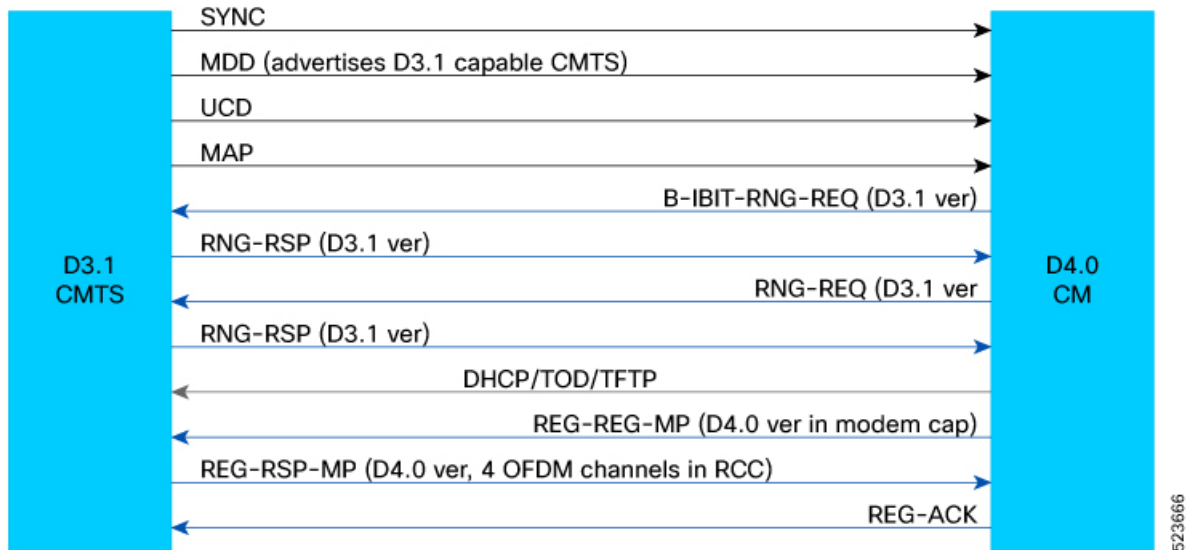

At the end of the call-flow shown in the above figure, a D4.0 modem is registered in D4.0 mode on the cBR-8 router and operates in D3.1 mode. The MAC Domain which the modem is registering on is in D3.1 mode, as advertised in the MDD messages for that MAC Domain.

Use the `show cable modem docsis version d40-capable [ not-operational | operational ]` command to view these modems on cBR-8 routers. Only modems that have registered in D4.0 mode are displayed in this command. This includes modems that are both D4.0 operational or D4.0 registered/D3.1 operational.

- Modems that are both registered and operational in D4.0 mode are displayed in the **operational** CLI option of the `d40-capable` command. In Cisco IOS XE Dublin 17.12.1x, the cBR-8 does not support D4.0 mode in the MAC Domain and so no modems that are D4.0 registered are D4.0 operational. Therefore, the output of the **operational** CLI option is empty.
- Modems that are D4.0 registered and D3.1 operational are considered **not-operational** from the D4.0 standpoint and are displayed as part of the **not-operational** CLI option for the `show cable modem docsis version d40-capable [ not-operational | operational ]` command.

Starting with Cisco IOS XE Dublin 17.12.1x,

- An MRC/MTC column is added to the command output of the existing `show cable modem docsis version d31-capable` command. MRC/MTC information can help the operator distinguish these D4.0 modems from traditional D3.1 modems. MRC/MTC is greater than 2/2 for D4.0 modems.
- The output of the `show cable modem verbose` command is updated to display D40 cable modem Capabilities.
- DOCSIS 4.0 modems advertising as DOCSIS 3.1 capable during registration are included in the `show cable modem docsis version d31-capable [ operational | not-operational ]` command. Such modems display more than 2 OFDM channels available in the **MRC** column of the command output.
- DOCSIS 4.0 modems advertising as DOCSIS 4.0 capable during registration are included in the `show cable modem docsis version d40-capable [ operational | not-operational ]` command. Such modems register as DOCSIS 3.1 operational.



Starting with Cisco IOS XE Dublin 17.12.1z,

- DOCSIS 4.0 modems support a new configuration **cable d40-mode** in the mac domain. This configuration is not required for 4xOFDM bonding. It enables the advertisement of additional D4.0 specific diplexer TLVs in the MDD.
- cBR now supports the Data Rate TLV within modem configuration files in 17.12.1z. This can be used to control service flow traffic rate QoS parameters between 4Gbps and max rate.
- The following example shows the configuration for the **show cable modem prof-mgmt downstream** command:

```
Router#show cable modem 206a.9454.30a4 prof-mgmt downstream
Downstream Profile Management Data:
MAC Address           : 206a.9454.30a4
IP Address            : 9.32.0.43
IPv6 Address          : ---
RxMer Exempt Percent  : 2
RxMer Margin qdB     : 0
Automatic Prof Dwngrd : Active
Internal PMA         : Active
Unfit Profile Aging   : Active
DCID                  : 159
  Configured Profile(s)      : 0 1 2
  Profile(s) in REG-RSP-MP   : 0 1 2
  Profile(s) in DBC-REQ      : N/A
  Current profile            : 0 [1024-QAM]
  Percentages of ideal BL vs Curr Prof : 99 (better) 0 (equal)
  External Profile Management (PMA) : Inactive
  Downgrade profile         : 0
  Recommend profile         : 1
  Unfit profile(s)          : N/A
  Recommend profile (Expired) : N/A
  Unfit profile(s) (Expired) : N/A
  Flow to Profile override   : Inactive
Number of SubCarriers      : 4096
1st Active SubCarrier      : 1126
# of Active SubCarriers    : 1844
Tx Time                    : 0h:30m:22s ago (Jun 24 11:57:18.000)
Rx Time                    : 0h:30m:22s ago (Jun 24 11:57:18.000)
OFDM Profile Failure Rx    : 0h:14m:48s ago (Jun 24 12:12:52.000)
OFDM Profile Recover Rx    : 0h:14m:45s ago (Jun 24 12:12:55.000)
MER Poll Period (min)     : 60
Recommend Timeout (min)   : 120
Unfit Timeout (min)       : 60
Unfit Profile Hysteresis (sec): Disabled
Source                    : OPT
Sub-      RxMER
SC RxMER Distribution (Excluded SCs counted as 0):
Each *: 2%
>44dB: ***** 19.46%
 44dB: ***** 36.00%
 43dB: ***** 33.78%
 42dB: ****  9.32%
 41dB:  1.30%
 40dB:  0.05%
 39dB:
 38dB:
 37dB:
 36dB:
 35dB:
 34dB:
```

```
33dB:
<33dB: 0.05%
```



## PART IV

# Layer 2 and DOCSIS 3.0 Configuration

- [Downstream Interface Configuration, on page 201](#)
- [Upstream Interface Configuration, on page 215](#)
- [DOCSIS Interface and Fiber Node Configuration, on page 223](#)
- [Service Group Based Configuration of the Cisco cBR Router, on page 243](#)
- [DOCSIS Load Balancing Groups, on page 253](#)
- [DOCSIS Load Balancing Movements, on page 283](#)
- [DOCSIS 3.0 Downstream Bonding, on page 321](#)
- [DOCSIS 2.0 A-TDMA Modulation Profiles , on page 343](#)
- [Downstream Resiliency Bonding Group , on page 361](#)
- [Downstream Channel ID Assignment, on page 381](#)
- [Upstream Channel Bonding, on page 391](#)
- [Dynamic Bonding Group, on page 425](#)
- [Spectrum Management and Advanced Spectrum Management, on page 441](#)
- [Upstream Scheduler Mode , on page 493](#)
- [Generic Routing Encapsulation, on page 499](#)
- [Transparent LAN Service over Cable , on page 523](#)
- [Downgrading Channel Bonding in Battery Backup Mode, on page 535](#)
- [Upstream Bonding Support for D-PON, on page 547](#)
- [Energy Management Mode, on page 555](#)
- [Cable Modem Steering, on page 567](#)
- [DOCSIS Predictive Scheduler, on page 577](#)





## CHAPTER 13

# Downstream Interface Configuration

---

This document describes how to configure the downstream interfaces on the Cisco cBR Series Converged Broadband Router.

- [Finding Feature Information, on page 201](#)
- [Hardware Compatibility Matrix for the Cisco cBR Series Routers, on page 201](#)
- [Information About Downstream Interface Configuration , on page 203](#)
- [How to Configure Downstream Interfaces, on page 205](#)
- [Configuration Examples, on page 209](#)
- [Additional References, on page 212](#)
- [Feature Information for Downstream Interface Configuration on the Cisco cBR Router, on page 213](#)

## Finding Feature Information

Your software release may not support all the features that are documented in this module. For the latest feature information and caveats, see the release notes for your platform and software release. The Feature Information Table at the end of this document provides information about the documented features and lists the releases in which each feature is supported.

Use Cisco Feature Navigator to find information about platform support and Cisco software image support. To access Cisco Feature Navigator, go to <http://tools.cisco.com/ITDIT/CFN/>. An account on <http://www.cisco.com/> is not required.

## Hardware Compatibility Matrix for the Cisco cBR Series Routers



---

**Note** The hardware components that are introduced in a given Cisco IOS-XE Release are supported in all subsequent releases unless otherwise specified.

---

Table 37: Hardware Compatibility Matrix for the Cisco cBR Series Routers

Cisco CMTS Platform	Processor Engine	Interface Cards
Cisco cBR-8 Converged Broadband Router	<p><b>Cisco IOS-XE Release 16.5.1 and Later Releases</b></p> <p>Cisco cBR-8 Supervisor:</p> <ul style="list-style-type: none"> <li>• PID—CBR-SUP-250G</li> <li>• PID—CBR-CCAP-SUP-160G</li> </ul>	<p><b>Cisco IOS-XE Release 16.5.1 and Later Releases</b></p> <p>Cisco cBR-8 CCAP Line Cards:</p> <ul style="list-style-type: none"> <li>• PID—CBR-LC-8D30-16U30</li> <li>• PID—CBR-LC-8D31-16U30</li> <li>• PID—CBR-RF-PIC</li> <li>• PID—CBR-RF-PROT-PIC</li> <li>• PID—CBR-CCAP-LC-40G</li> <li>• PID—CBR-CCAP-LC-40G-R</li> <li>• PID—CBR-CCAP-LC-G2-R</li> <li>• PID—CBR-SUP-8X10G-PIC</li> <li>• PID—CBR-2X100G-PIC</li> </ul> <p>Digital PICs:</p> <ul style="list-style-type: none"> <li>• PID—CBR-DPIC-8X10G</li> <li>• PID—CBR-DPIC-2X100G</li> </ul> <p>Cisco cBR-8 Downstream PHY Module:</p> <ul style="list-style-type: none"> <li>• PID—CBR-D31-DS-MOD</li> </ul> <p>Cisco cBR-8 Upstream PHY Modules:</p> <ul style="list-style-type: none"> <li>• PID—CBR-D31-US-MOD</li> </ul>



**Note** Do not use DPICs (8X10G and 2x100G) to forward IP traffic, as it may cause buffer exhaustion, leading to line card reload.

The only allowed traffic on a DPIC interface is DEPI, UEPI, and GCP traffic from the Cisco cBR-8 router to Remote PHY devices. Other traffic such as DHCP, SSH, and UTSC should flow via another router, since DPICs cannot be used for normal routing.

# Information About Downstream Interface Configuration

## Overview

- Each downstream port requires port level configuration and channel level configuration. Port level configuration is optimized with a frequency profile that defines ranges of frequencies available on the port. Channel level configuration is optimized with a QAM profile and channel range configuration block that auto-increments frequency and duplicates annex, modulation, and interleaver.
- Each channel requires a set of parameters: frequency, annex, modulation, interleaver, and DOCSIS channel id.
- Configuration is done in 4 major blocks of configuration:
  - QAM Profile—Example: “cable downstream qam-profile 1”
  - Frequency Profile—Example: “cable downstream freq-profile 2”
  - Port/Controller—Example: “controller Integrated-Cable 3/0/0”
  - RF Channel block—Example: “rf-chan 0 31”

## Downstream RF Port and Channel Management

The downstream RF port and channel management feature is responsible for the configuration and management of the downstream RF ports and channels. Each downstream RF channel can be provisioned either as a DOCSIS or traditional MPEG video QAM channel.

## QAM Profile

A QAM profile describes the common downstream channel modulator settings, referred to as physical layer parameters. This includes QAM constellation, symbol rate, interleaver-depth, spectrum-inversion, and annex. The QAM profile is described by *CCAP DownPhyParams* object. Default QAM profiles are supported and customized for DOCSIS or MPEG Video, which are described as *DocsisPhyDefault* and *VideoPhyDefault* objects, respectively.

A maximum of 32 QAM profiles can be defined. There are six system-defined QAM profiles (0 to 5), which cannot be deleted or modified. You can define profiles 6 to 31.

The system defined profiles are:

- Profile 0 - default-annex-b-64-qam
  - interleaver-depth: I32-J4
  - symbol rate: 5057 kilo-symbol/second
  - spectrum-inversion: off
- Profile 1 - default-annex-b-256-qam
  - interleaver-depth: I32-J4
  - symbol rate: 5361 kilo-symbol/second

- spectrum-inversion: off
- Profile 2 - default-annex-a-64-qam
  - interleaver-depth: I12-J17
  - symbol rate: 6952 kilo-symbol/second
  - spectrum-inversion: off
- Profile 3 - default-annex-a-256-qam
  - interleaver-depth: I12-J17
  - symbol rate: 6952 kilo-symbol/second
  - spectrum-inversion: off
- Profile 4 - default-annex-b-64-qam
  - interleaver-depth: I128-J1
  - symbol rate: 5057 kilo-symbol/second
  - spectrum-inversion: off
- Profile 5 - default-annex-b-256-qam
  - interleaver-depth: I128-J1
  - symbol rate: 5361 kilo-symbol/second
  - spectrum-inversion: off

### Spectrum Inversion

Spectrum inversion happens as a result of mixing processes in RF or IF electronics. Spectrum inversion allows for the adaptation of older equipment with the new plant. The mixing of I and Q are used to create a quadrant profile. For some settops, the inversion of the quadrant profile is needed where the axis are flipped such that I represents the X and Q represents the Y-axis. Most modern equipment can detect and resolve the inversion split.

You can change this spectrum inversion configuration on a user-defined qam-profile. It cannot be changed on a system generated qam-profile from 0 to 5.

### Frequency Profile

A frequency profile defines the ranges of frequencies available on a port. A maximum of 16 frequency profiles can be defined. There are four system-defined frequency profiles (0 to 3), which cannot be deleted or modified. You can define profiles 4 to 15.

The system defined profiles are:

- Profile 0 - annex-b-low, Frequency range (Hz): 90000000 - 863999999
- Profile 1 - annex-b-high, Frequency range (Hz): 234000000 - 1002999999
- Profile 2 - annex-a-low, Frequency range (Hz): 94000000 - 867999999



- Profile 3 - annex-a-high, Frequency range (Hz): 267000000 - 1002999999

The frequency ranges are defined using lanes and blocks:

- Four lanes per port, each lane can support 216 MHz range.
- Four blocks per lane, each block can support 54 MHz range.
- Lanes and blocks may have overlapping frequency ranges.

## How to Configure Downstream Interfaces

This section contains the following:

### Configuring the Cisco CMTS Manually Using Configuration Mode

Connect a console terminal to the console port on the I/O controller. When asked if you want to enter the initial dialog, answer **no** to go into the normal operating mode of the router. After a few seconds the user EXEC prompt (**Router>**) appears.

### Configuring the QAM Profile on the Downstream Channels

#### Procedure

	Command or Action	Purpose
<b>Step 1</b>	<b>enable</b> <b>Example:</b> Router> <b>enable</b>	Enables privileged EXEC mode. Enter your password if prompted.
<b>Step 2</b>	<b>configure terminal</b> <b>Example:</b> Router# <b>configure terminal</b>	Enters global configuration mode.
<b>Step 3</b>	<b>cable downstream qam-profile</b> <i>Qam_Profile_ID</i> <b>Example:</b> Router(config)# <b>cable downstream qam-profile 3</b>	Defines or modifies a QAM profile.
<b>Step 4</b>	<b>annex</b> {A   B   C} <b>Example:</b> Router(config-qam-prof) # <b>annex A</b>	Defines the profile MPEG framing format. The default is Annex B.
<b>Step 5</b>	<b>description</b> <i>LINE</i> <b>Example:</b> Router(config-qam-prof) # <b>description qam1</b>	Name or description for this profile.

	Command or Action	Purpose
<b>Step 6</b>	<b>interleaver-depth</b> {I12-J17   I128-J1   I128-J2   I128-J3   I128-J4   I128-J5   I128-J6   I128-J7   I128-J8   I16-J8   I32-J4   I64-J2   I8-J16} <b>Example:</b> Router(config-qam-prof) # <b>interleaver-depth I64-J2</b>	Defines the interleaver depth. The default is I32 J4 for DOCSIS.
<b>Step 7</b>	<b>modulation</b> {256   64} <b>Example:</b> Router(config-qam-prof) # <b>modulation 64</b>	Defines the modulation. The default is 256QAM.
<b>Step 8</b>	<b>spectrum-inversion</b> {off   on} <b>Example:</b> Router(config-qam-prof) # <b>spectrum-inversion on</b>	Enables or disables spectrum inversion. Default is off.
<b>Step 9</b>	<b>symbol-rate</b> <i>value</i> <b>Example:</b> Router(config-qam-prof) # <b>symbol-rate 5057</b>	Defines the symbol rate. Value is in kilo-symbol/sec.
<b>Step 10</b>	<b>exit</b> <b>Example:</b> Router(config-qam-prof) # <b>exit</b>	Exits from the QAM profile configuration mode.

## Configuring the Frequency Profile on the Downstream Channels

### Procedure

	Command or Action	Purpose
<b>Step 1</b>	<b>enable</b> <b>Example:</b> Router> <b>enable</b>	Enables privileged EXEC mode. Enter your password if prompted.
<b>Step 2</b>	<b>configure terminal</b> <b>Example:</b> Router# <b>configure terminal</b>	Enters global configuration mode.
<b>Step 3</b>	<b>cable downstream freq-profile</b> <i>DS_frequency_profile_ID</i> <b>Example:</b> Router(config) # <b>cable downstream freq-profile 4</b>	Defines or modifies a frequency profile.
<b>Step 4</b>	<b>exit</b> <b>Example:</b> Router(config) # <b>exit</b>	Exits from the frequency lane configuration mode.

## Configuring the Controller on the Downstream Channels

### Procedure

	Command or Action	Purpose
Step 1	<b>enable</b> <b>Example:</b> Router> <b>enable</b>	Enables privileged EXEC mode. Enter your password if prompted.
Step 2	<b>configure terminal</b> <b>Example:</b> Router# <b>configure terminal</b>	Enters global configuration mode.
Step 3	<b>controller integrated-cable slot/subslot/port</b> <b>Example:</b> Router(config)# <b>controller Integrated-Cable 3/0/0</b>	Enters the controller sub-mode.
Step 4	<b>base-channel-power value</b> <b>Example:</b> Router(config-controller)# <b>base-channel-power 26</b>	Sets the base channel power level. If not specified, the default value is calculated based on the number of carriers. Maximum limit is 34 dBmV DRFI. If you configure a value greater than the maximum specified by DRFI, the following message is displayed:  Caution: RF Power above DRFI specification. May result in minor fidelity degradation.
Step 5	<b>freq-profile number</b> <b>Example:</b> Router(config-controller)# <b>freq-profile 0</b>	Specifies the frequency profile for the port.
Step 6	<b>max-carrier value</b> <b>Example:</b> Router(config-controller)# <b>max-carrier 1</b>	Specifies the maximum number of carriers.
Step 7	<b>mute</b> <b>Example:</b> Router(config-controller)# <b>mute</b>	Mutes the port. Use the <b>no</b> prefix to unmute the port. Default is "no mute".
Step 8	<b>rf-chan starting_Qam_ID ending_Qam_ID</b> <b>Example:</b> Router(config-controller)# <b>rf-chan 0 1</b>	Enters RF channel configuration sub-mode to configure an individual channel or a block of channels.
Step 9	<b>shutdown</b> <b>Example:</b> Router(config-controller)# <b>shutdown</b>	Changes the port administration state to down. Use the <b>no</b> prefix to change the port administration state to up.

## Troubleshooting Tips

### Shutting and No Shutting Downstream Controller Immediately

**Problem** Shutting down a downstream controller on a cable line card and bringing the controller back up immediately can cause a Queue ID Pending Drain event on the system. This results in traffic disruption to the modems or modems going offline.

**Solution** It is recommended that you wait for a few seconds (>30 secs) before issuing the no shut command on a shut downstream controller. The system also restricts the user from issuing the no shut command immediately by printing this message.

```
Config change could not be applied as a cleanup is pending following shut on
controller x/x/x. Please wait for the cleanup to complete before attempting to
no shut controller.
```

## Configuring the RF Channel on a Controller

The RF channel submode is entered from the channel controller configuration submode using the **rf-chan** command as described in the previous section. If an individual channel was specified in the **rf-chan** command, only that channel configuration is changed. If a block of channels was specified in the **rf-chan** command, the configuration change is applied to all channels in the block.



**Note** If the user tries to add a video type RF channel to a cable interface, the following message appears to reject the configuration:

```
X/X/X rf-channel XX is video type channel, it can't be configured as primary DS
```

If a RF channel is configured under cable interface, when the user tries to change the channel type to video, the following message appears to reject the configuration:

```
X/X/X rf channel X can't be set to video type.
It is configured under Cable1/0/1.
Please remove the configuration before change the qam type
```

### Step 1 **docsis-channel-id** *dcid*

#### Example:

```
Router(config-rf-chan)#docsis-channel-id 1
```

Changes the channel DOCSIS channel identifier. In block mode, the value is assigned to the first channel and incremented for successive channels.

### Step 2 **frequency** *value*

#### Example:

```
Router(config-rf-chan)#frequency 93000000
```

Configures the channel's center frequency in Hz. The available frequency range is determined from the port's frequency profile, if configured. If not configured, the available range will be the full port spectrum. In block mode, the frequency will be assigned to the first channel. Successive channels will get the next center frequency for the annex specified in the QAM profile (+6 Hz for Annex B, +8 Hz for Annex A).

**Step 3**     **mute****Example:**

```
Router(config-rf-chan)#mute
```

Mutes the RF channel. Enter the **no** prefix to unmute the channel. Default is "no mute".

**Step 4**     **power-adjust** *pwr\_adj\_range***Example:**

```
Router(config-rf-chan)#power-adjust 8.0 - 0.0 dBmV
```

Adjusts the RF channel's power.

**Step 5**     **qam-profile** *qam\_profile\_number***Example:**

```
Router(config-rf-chan)#qam-profile 0
```

Specifies the QAM profile for this channel.

**Step 6**     **rf-output** *value***Example:**

```
Router(config-rf-chan)#rf-output normal
```

Changes the RF output mode to test the channel.

**Step 7**     **shutdown****Example:**

```
Router(config-rf-chan)#shutdown
```

Changes the channel administration state to down. Use the **no** prefix to change the channel administration state to up. The default is "no shut".

**Step 8**     **type** *value***Example:**

```
Router(config-rf-chan)#type video
```

Configures the channel QAM type. The default is DOCSIS.

---

## Configuration Examples

### Downstream Interface Configuration Example

The example below shows the configuration of:

- QAM Profile—The system defined QAM profile for Annex B and 256 QAM.
- Frequency Profile—The system defined frequency profile annex-b-low.
- Controller and RF channel—Port 0 on slot 3/0 with frequency profile 0; 96 channels with QAM profile 1 and center frequencies starting at 93 MHz.

```

cable downstream qam-profile 1
  annex B
  modulation 256
  interleaver-depth I32-J4
  symbol-rate 5361
  spectrum-inversion off
  description default-annex-b-256-qam
cable downstream freq-profile 0
  lane 1 start-freq 90000000
    block 1 start-freq 90000000
    block 2 start-freq 138000000
    block 3 start-freq 186000000
    block 4 start-freq 234000000
  lane 2 start-freq 282000000
    block 1 start-freq 282000000
    block 2 start-freq 330000000
    block 3 start-freq 378000000
    block 4 start-freq 426000000
  lane 3 start-freq 474000000
    block 1 start-freq 474000000
    block 2 start-freq 522000000
    block 3 start-freq 570000000
    block 4 start-freq 618000000
  lane 4 start-freq 666000000
    block 1 start-freq 666000000
    block 2 start-freq 714000000
    block 3 start-freq 762000000
    block 4 start-freq 810000000
controller Integrated-Cable 3/0/0
  max-carrier 128
  base-channel-power 34
  freq-profile 0
  rf-chan 0 95
  type DOCSIS
  frequency 93000000
  rf-output NORMAL
  power-adjust 0
  docsis-channel-id 1
  qam-profile 1

```

### Show Command Examples for Displaying the State

Use the following commands to display the state of any QAM profile, Frequency profile, downstream controller or channel.

#### QAM Profile Configuration Example

```

Router#show cable qam-profile 0
QAM Profile ID 0: default-annex-b-64-qam
  annex: B
  modulation: 64
  interleaver-depth: I32-J4
  symbol rate: 5057 kilo-symbol/second
  spectrum-inversion: off
Router#

```

## Frequency Profile Configuration Example

```
Router#show cable freq-profile 0
Frequency Profile ID 0 annex-b-low:
  Lane 1 start-freq 900000000hz
    Block 1 start-freq 900000000hz
    Block 2 start-freq 1380000000hz
    Block 3 start-freq 1860000000hz
    Block 4 start-freq 2340000000hz
  Lane 2 start-freq 2820000000hz
    Block 1 start-freq 2820000000hz
    Block 2 start-freq 3300000000hz
    Block 3 start-freq 3780000000hz
    Block 4 start-freq 4260000000hz
  Lane 3 start-freq 4740000000hz
    Block 1 start-freq 4740000000hz
    Block 2 start-freq 5220000000hz
    Block 3 start-freq 5700000000hz
    Block 4 start-freq 6180000000hz
  Lane 4 start-freq 6660000000hz
    Block 1 start-freq 6660000000hz
    Block 2 start-freq 7140000000hz
    Block 3 start-freq 7620000000hz
    Block 4 start-freq 8100000000hz

Router#
```

## Controller Configuration Example

```
Router#show controller Integrated-Cable 3/0/0 rf-port
Admin: UP MaxCarrier: 128 BasePower: 34 dBmV Mode: normal
Rf Module 0: UP
Frequency profile: 0
Free freq block list has 1 blocks:
  666000000 - 863999999
Rf Port Status: UP

Router#
```

## RF Channel Configuration Example

```
Router#show controller integrated-Cable 3/0/0 rf-channel 0-3 95
Chan State Admin Frequency Type Annex Mod srate Interleaver dcid power output
0 UP UP 93000000 DOCSIS B 256 5361 I32-J4 1 34 NORMAL
1 UP UP 99000000 DOCSIS B 256 5361 I32-J4 2 34 NORMAL
2 UP UP 105000000 DOCSIS B 256 5361 I32-J4 3 34 NORMAL
3 UP UP 111000000 DOCSIS B 256 5361 I32-J4 4 34 NORMAL
95 UP UP 663000000 DOCSIS B 256 5361 I32-J4 96 34 NORMAL
```

```
Router# show controller integrated-Cable 3/0/0 rf-channel 0 verbose
Chan State Admin Frequency Type Annex Mod srate Interleaver dcid power output
0 UP UP 93000000 DOCSIS B 256 5361 I32-J4 1 34 NORMAL
Qam profile: 1
Spectrum Inversion: Off
Frequency Lane: 1 Block: 1 index: 1
Resource status: OK
License: granted <02:00:04 EDT Jan 2 2012>
JIB channel number: 0
Chan EnqQ Pipe RAF SyncTmr Vid Mac Video Primary DqQ TM Mpts Sniff
0 0 0 4 0 0 0000.0000.0000 0 0 0 0 0 NO
Grp Prio P Prate Phy0-ctl Phyl-ctl Enable Tun-Id L2TPv3_Ses_id
0 0 0 1 1 0 TRUE 0 0
Chan Qos-Hi Qos-Lo Med-Hi Med-Lo Low-Hi Low-Lo
0 32774 16384 32768 16384 65536 32768
```

```

Chan  Med Low TB-neg Qos_Exc  Med_Xof  Low_Xof      Qdrops  Pos Qlen(Hi-Med-lo) Fl
    0   0  0      0      0      0      0      0  Y    0    0    0  0
DSPHY Info:
  DSPHY Register Local Copy: QPRHI = c0000163, QPRLO = e30d0
  DSPHY Register Local Copy Vaddr = 80000290, qam2max_mapping = 80000000
  DSPHY Register Local Copy: SPR ID = 0, SPR Mapping= c200000a
  Last read from HW: Mon Jan  2 02:02:04 2012
  QPRHI = c0000163, QPRLO = e30d0, SPR = c200000a SPRMAPING c0000000 Q2Max 80000000
  Last time read spr rate info from HW: Mon Jan  2 13:21:41 2012
  SPR ID 0, rate value in kbps 0, overflow count 0, underflow count 0

```

```

Router# sh controllers Integrated-Cable 7/0/0 counter rf-channel
Controller  RF    MPEG    MPEG    MPEG    Sync    MAP/UCD    User    QAM
           Chan  Packets  bps      Mbps    Packets  Packets    Mbps    Util
           Chan  Packets  Tx       Tx       Tx       Tx       Tx       Percentage
7/0/0      0     0        0        00.00   0        0          00.00   000.00
7/0/0      1     0        0        00.00   0        0          00.00   000.00
7/0/0      2     8239954  2475952  02.47   0        0          02.39   006.60
7/0/0      3     85927382 25769779 25.76   0        0          24.94   068.71
7/0/0      4     85927608 25769027 25.76   0        0          24.94   068.71
7/0/0      5     8239088  2474599  02.47   0        0          02.39   006.59
7/0/0      6     8210840  2463770  02.46   0        0          02.38   006.57
7/0/0      7     50103    15040    00.01   0        0          00.01   000.04
7/0/0      8     50103    15040    00.01   0        0          00.01   000.04

```

```

Router# show cable licenses ds
-----
Entitlement:  Downstream License
Consumed count: 672
Consumed count reported to SmartAgent: 672
Forced-Shut count: 0
Enforced state: No Enforcement

Router#

```

## Additional References

### Technical Assistance

Description	Link
<p>The Cisco Support website provides extensive online resources, including documentation and tools for troubleshooting and resolving technical issues with Cisco products and technologies.</p> <p>To receive security and technical information about your products, you can subscribe to various services, such as the Product Alert Tool (accessed from Field Notices), the Cisco Technical Services Newsletter, and Really Simple Syndication (RSS) Feeds.</p> <p>Access to most tools on the Cisco Support website requires a Cisco.com user ID and password.</p>	<a href="http://www.cisco.com/support">http://www.cisco.com/support</a>



# Feature Information for Downstream Interface Configuration on the Cisco cBR Router

Use Cisco Feature Navigator to find information about the platform support and software image support. Cisco Feature Navigator enables you to determine which software images support a specific software release, feature set, or platform. To access Cisco Feature Navigator, go to the <https://cfmg.cisco.com/> link. An account on the Cisco.com page is not required.



**Note** The following table lists the software release in which a given feature is introduced. Unless noted otherwise, subsequent releases of that software release train also support that feature.

**Table 38: Feature Information for Downstream Interface Configuration**

Feature Name	Releases	Feature Information
Downstream Interface Configuration	Cisco IOS XE Fuji 16.7.1	This feature was integrated on the Cisco cBR Series Converged Broadband Routers.
Display QAM Utilization Percentage using the <b>sh controllers Integrated-Cable 7/0/0 counter rf-channel</b>	Cisco IOS XE Gibraltar 16.10.1f	This feature was integrated on the Cisco cBR Series Converged Broadband Routers.





## CHAPTER 14

# Upstream Interface Configuration

---

This document describes how to configure the upstream interfaces on the Cisco cBR Series Converged Broadband Router.

- [Finding Feature Information, on page 215](#)
- [Hardware Compatibility Matrix for the Cisco cBR Series Routers, on page 215](#)
- [Information About Upstream Interface Configuration, on page 217](#)
- [How to Configure Upstream Interfaces, on page 217](#)
- [Configuration Examples, on page 221](#)
- [Additional References, on page 222](#)
- [Feature Information for Upstream Interface Configuration on the Cisco cBR Router, on page 222](#)

## Finding Feature Information

Your software release may not support all the features that are documented in this module. For the latest feature information and caveats, see the release notes for your platform and software release. The Feature Information Table at the end of this document provides information about the documented features and lists the releases in which each feature is supported.

Use Cisco Feature Navigator to find information about platform support and Cisco software image support. To access Cisco Feature Navigator, go to <http://tools.cisco.com/ITDIT/CFN/>. An account on <http://www.cisco.com/> is not required.

## Hardware Compatibility Matrix for the Cisco cBR Series Routers



---

**Note** The hardware components that are introduced in a given Cisco IOS-XE Release are supported in all subsequent releases unless otherwise specified.

---

Table 39: Hardware Compatibility Matrix for the Cisco cBR Series Routers

Cisco CMTS Platform	Processor Engine	Interface Cards
Cisco cBR-8 Converged Broadband Router	<p><b>Cisco IOS-XE Release 16.5.1 and Later Releases</b></p> <p>Cisco cBR-8 Supervisor:</p> <ul style="list-style-type: none"> <li>• PID—CBR-SUP-250G</li> <li>• PID—CBR-CCAP-SUP-160G</li> </ul>	<p><b>Cisco IOS-XE Release 16.5.1 and Later Releases</b></p> <p>Cisco cBR-8 CCAP Line Cards:</p> <ul style="list-style-type: none"> <li>• PID—CBR-LC-8D30-16U30</li> <li>• PID—CBR-LC-8D31-16U30</li> <li>• PID—CBR-RF-PIC</li> <li>• PID—CBR-RF-PROT-PIC</li> <li>• PID—CBR-CCAP-LC-40G</li> <li>• PID—CBR-CCAP-LC-40G-R</li> <li>• PID—CBR-CCAP-LC-G2-R</li> <li>• PID—CBR-SUP-8X10G-PIC</li> <li>• PID—CBR-2X100G-PIC</li> </ul> <p>Digital PICs:</p> <ul style="list-style-type: none"> <li>• PID—CBR-DPIC-8X10G</li> <li>• PID—CBR-DPIC-2X100G</li> </ul> <p>Cisco cBR-8 Downstream PHY Module:</p> <ul style="list-style-type: none"> <li>• PID—CBR-D31-DS-MOD</li> </ul> <p>Cisco cBR-8 Upstream PHY Modules:</p> <ul style="list-style-type: none"> <li>• PID—CBR-D31-US-MOD</li> </ul>



**Note** Do not use DPICs (8X10G and 2x100G) to forward IP traffic, as it may cause buffer exhaustion, leading to line card reload.

The only allowed traffic on a DPIC interface is DEPI, UEPI, and GCP traffic from the Cisco cBR-8 router to Remote PHY devices. Other traffic such as DHCP, SSH, and UTSC should flow via another router, since DPICs cannot be used for normal routing.

# Information About Upstream Interface Configuration

The cable interface in the Cisco cBR router supports upstream signals and serves as the radio frequency (RF) interface. This chapter provides an overview of the upstream interfaces on the Cisco cBR Series Converged Broadband Router.

Cisco IOS XE Fuji 16.9.1 and later releases support 10 Gbps of upstream throughput on the following line cards on the Cisco cBR Series Converged Broadband Router:

- CBR-CCAP-LC-40G
- CBR-CCAP-LC-40G-R

## Upstream Channel Management

Upstream Channel Management (UCM) is responsible for the physical (PHY) layer configuration and resource management of upstream channels in the Cisco cBR Series Converged Broadband Router.

## Upstream Controller

An upstream port represents a physical upstream RF connector on a cable line card, connected to one or more fiber nodes. An upstream RF port is a container of upstream RF channels, which imposes constraints on both topology and spectrum for the group of RF channels contained in the physical port. An upstream RF port also represents the RF front-end hardware component on a cable line card including the connector, variable gain adjustment (VGA), and A/D converter. This is directly connected to a set of upstream physical channel receivers. The number of upstream physical channels per port is thus constrained by the number of receivers accessible to the port.

## Upstream Channel

An upstream RF channel represents DOCSIS physical layer operation on a single upstream center frequency with a particular channel width. It is contained by a single physical port on the CMTS line card hardware.

## Upstream Resource Management

The upstream resource management (URM) feature is primarily responsible for the maintenance of the relationship between a physical upstream connector on the line card and the upstream RF channels received on that connector.

# How to Configure Upstream Interfaces

This section contains the following:

## Configuring the Cisco CMTS Manually Using Configuration Mode

Connect a console terminal to the console port on the I/O controller. When asked if you want to enter the initial dialog, answer **no** to go into the normal operating mode of the router. After a few seconds the user EXEC prompt (**Router>**) appears.

## Configuring the Modulation Profile and Assigning to an Upstream Channel

### Procedure

	Command or Action	Purpose
<b>Step 1</b>	<b>enable</b> <b>Example:</b> Router> <b>enable</b>	Enables privileged EXEC mode. Enter your password if prompted.
<b>Step 2</b>	<b>configure terminal</b> <b>Example:</b> Router# <b>configure terminal</b>	Enters global configuration mode.
<b>Step 3</b>	<b>cable modulation-profile</b> <i>profile mode_of_oper qam_profile</i> <b>Example:</b> Router(config)# <b>cable modulation-profile 23 tdma qam-16</b>	Creates a preconfigured modulation profile, where the burst parameters are set to their default values for each burst type.
<b>Step 4</b>	<b>Controller Upstream-Cable</b> <i>slot/subslot/port</i> <b>Example:</b> Router(config)# <b>Controller Upstream-Cable 7/0/0</b>	Enters the controller interface configuration mode.
<b>Step 5</b>	<b>us-channel</b> <i>n modulation-profile primary-profile-number [secondary-profile-number] [tertiary-profile-number]</i> <b>Example:</b> Router(config-if)# <b>cable upstream-us-channel 0 modulation-profile 23</b>	Assigns up to three modulation profiles to an upstream port.
<b>Step 6</b>	<b>end</b> <b>Example:</b> Router(config-controller)# <b>end</b>	Exits controller configuration submode and returns to privileged EXEC mode.

## Configuring the Upstream Channel with PHY Layer

### Procedure

	Command or Action	Purpose
<b>Step 1</b>	<b>enable</b> <b>Example:</b> Router> <b>enable</b>	Enables privileged EXEC mode. Enter your password if prompted.
<b>Step 2</b>	<b>configure terminal</b> <b>Example:</b>	Enters global configuration mode.

	Command or Action	Purpose
	Router# <b>configure terminal</b>	
<b>Step 3</b>	<b>controller upstream-cable</b> <i>slot/subslot/port</i> <b>Example:</b> Router(config)# <b>controller upstream-cable</b> 1/0/0	Specifies the controller interface line card and enters upstream controller config configuration submode.
<b>Step 4</b>	<b>us-channel rf-channel frequency</b> <i>freq-val</i> <b>Example:</b> Router(config-controller)# <b>us-channel 1 frequency</b> 20000000	Assigns frequency to an RF channel on a controller interface.
<b>Step 5</b>	<b>us-channel rf-channel docsis-mode</b> <i>mode</i> <b>Example:</b> Router(config-controller)# <b>us-channel 1 docsis-mode</b> <b>tdma</b>	Assigns DOCSIS mode to an RF channel on a controller interface.
<b>Step 6</b>	<b>us-channel rf-channel channel-width</b> <i>value</i> <b>Example:</b> Router(config-controller)# <b>us-channel 1 channel-width</b> 3200000	Assigns channel width in Hertz to an RF channel on a controller interface.
<b>Step 7</b>	<b>us-channel rf-channel modulation-profile</b> <i>profile</i> <b>Example:</b> Router(config-controller)# <b>us-channel 1 modulation-profile</b> 21	Assigns modulation profile to an RF channel on a controller interface.
<b>Step 8</b>	<b>no us-channel rf-channel shutdown</b> <b>Example:</b> Router(config-controller)# <b>no us-channel 1 shutdown</b>	Enables the upstream channel.
<b>Step 9</b>	<b>end</b> <b>Example:</b> Router(config-controller)# <b>end</b>	Exits upstream controller configuration submode and returns to privileged EXEC mode.

## Associating Upstream Channels with a MAC Domain and Configuring Upstream Bonding

### Procedure

	Command or Action	Purpose
<b>Step 1</b>	<b>enable</b> <b>Example:</b> Router> <b>enable</b>	Enables privileged EXEC mode. Enter your password if prompted.

	Command or Action	Purpose
<b>Step 2</b>	<b>configure terminal</b> <b>Example:</b> Router# <b>configure terminal</b>	Enters global configuration mode.
<b>Step 3</b>	<b>interface cable slot/subslot/cable-interface-index</b> <b>Example:</b> Router(config)# <b>interface cable 7/0/0</b>	Specifies the cable interface line card on a Cisco CMTS router.
<b>Step 4</b>	<b>downstream integrated-cable slot/subslot/port rf-channel rf-chan [upstream grouplist]</b> <b>Example:</b> Router(config-if)# <b>downstream integrated-cable 7/0/0 rf-channel 3 upstream 3</b>	Associates a set of upstream channels to the integrated downstream channels.
<b>Step 5</b>	<b>upstream md-us-chan-id upstream-cable slot/subslot/port us-channel rf-channel</b> <b>Example:</b> Router(config-if)# <b>upstream 0 upstream-cable 7/0/0 us-channel 0</b>	Associates a set of physical upstream channels with the Mac Domain.
<b>Step 6</b>	<b>cable upstream bonding-group id</b> <b>Example:</b> Router(config-if)# <b>cable upstream bonding-group 200</b>	Creates the upstream bonding group on the specified cable interface and enters upstream bonding configuration submode.
<b>Step 7</b>	<b>upstream number</b> <b>Example:</b> Router(config-upstream-bonding)# <b>upstream 1</b>	Adds an upstream channel to the upstream bonding group. A maximum of 16 upstream channels can be configured for each MAC Domain, which are divided into two groups: <ul style="list-style-type: none"> <li>• Group 1: upstream channel 0-7</li> <li>• Group 2: upstream channel 8-15</li> </ul> The <b>upstream bonding-group</b> should include all the upstream channels either from Group 1 or Group 2 only.
<b>Step 8</b>	<b>attributes value</b> <b>Example:</b> Router(config-upstream-bonding)# <b>attributes eeeeeeee</b>	Modifies the attribute value for the specified upstream bonding group.
<b>Step 9</b>	<b>end</b> <b>Example:</b> Router(config-upstream-bonding)# <b>end</b>	Exits upstream bonding configuration submode and returns to privileged EXEC mode.



## Configuring Upstream Channel Priority

Feature History

*Table 40: Feature History*

Feature Name	Release Information	Feature Description
Upstream Channel Priority	Cisco IOS XE Bengaluru 17.6.1w	This feature allows the cable modem to do the initial ranging on the upstream channel with the highest priority.

Starting from Cisco IOS XE Bengaluru 17.6.1w release, you can use the **cable upstream priority** command to configure the upstream channel with different priorities.

```
Router(config-if)# cable upstream 0 priority 1
```

You can also run this command for mac-domain profile.

```
Router(config-profile-md)# cable upstream 0 priority 2
```

Use **show cable mac-domain mdd | in MD-US** command to check the upstream channel priority.

```
Router#show cable mac-domain c3/0/1 mdd | in MD-US
MD-US Chan ID/CM-STATUS: 1/0x0000
MD-US Chan Priority: 3
MD-US Chan DCID Binding: 9 10 11 12 13 14 15 16
MD-US Chan ID/CM-STATUS: 2/0x0000
MD-US Chan Priority: 4
MD-US Chan DCID Binding: 9 10 11 12 13 14 15 16
MD-US Chan ID/CM-STATUS: 3/0x0000
MD-US Chan Priority: 5
MD-US Chan DCID Binding: 9 10 11 12 13 14 15 16
MD-US Chan ID/CM-STATUS: 4/0x0000
MD-US Chan Priority: 0
```

## Configuration Examples

### Upstream Channel with PHY Layer Configuration Example

```
...
us-channel 0 frequency 20000000
us-channel 0 channel-width 3200000 3200000
us-channel 0 power-level 0
us-channel 0 docsis-mode tdma
us-channel 0 minislots-size 2
us-channel 0 modulation-profile 21
no us-channel 0 shutdown
...
```

### Upstream Channels with a MAC Domain Configuration Example

```
...
interface Cable8/0/0
downstream Modular-Cable 8/0/0 rf-channel 0
upstream 0 Upstream-Cable 8/0/0 us-channel 0
upstream 1 Upstream-Cable 8/0/0 us-channel 1
```

```

cable mtc-mode
cable upstream bonding-group 1
  upstream 0
  upstream 1
  attributes 80000000
...

```

## Additional References

### Technical Assistance

Description	Link
<p>The Cisco Support website provides extensive online resources, including documentation and tools for troubleshooting and resolving technical issues with Cisco products and technologies.</p> <p>To receive security and technical information about your products, you can subscribe to various services, such as the Product Alert Tool (accessed from Field Notices), the Cisco Technical Services Newsletter, and Really Simple Syndication (RSS) Feeds.</p> <p>Access to most tools on the Cisco Support website requires a Cisco.com user ID and password.</p>	<a href="http://www.cisco.com/support">http://www.cisco.com/support</a>

## Feature Information for Upstream Interface Configuration on the Cisco cBR Router

Use Cisco Feature Navigator to find information about the platform support and software image support. Cisco Feature Navigator enables you to determine which software images support a specific software release, feature set, or platform. To access Cisco Feature Navigator, go to the <https://cfnng.cisco.com/> link. An account on the Cisco.com page is not required.



**Note** The following table lists the software release in which a given feature is introduced. Unless noted otherwise, subsequent releases of that software release train also support that feature.

*Table 41: Feature Information for Upstream Interface Configuration*

Feature Name	Releases	Feature Information
Upstream Interface Configuration	Cisco IOS XE Fuji 16.7.1	This feature was integrated on the Cisco cBR Series Converged Broadband Routers.



## CHAPTER 15

# DOCSIS Interface and Fiber Node Configuration

---

- [Hardware Compatibility Matrix for the Cisco cBR Series Routers](#), on page 223
- [Overview of DOCSIS Interfaces and Fiber Node Configurations](#), on page 225
- [Configuring DOCSIS Interfaces and Fiber Nodes](#), on page 226
- [Configuring MAC Domain Service Groups](#), on page 232
- [Downstream Bonding Group Configuration](#), on page 235
- [Upstream Bonding Group Configuration](#), on page 238
- [Additional References](#), on page 241
- [Feature Information for DOCSIS Interface and Fiber Node Configuration](#), on page 242

## Hardware Compatibility Matrix for the Cisco cBR Series Routers



---

**Note** The hardware components that are introduced in a given Cisco IOS-XE Release are supported in all subsequent releases unless otherwise specified.

---

Table 42: Hardware Compatibility Matrix for the Cisco cBR Series Routers

Cisco CMTS Platform	Processor Engine	Interface Cards
Cisco cBR-8 Converged Broadband Router	<b>Cisco IOS-XE Release 16.5.1 and Later Releases</b> Cisco cBR-8 Supervisor: <ul style="list-style-type: none"> <li>• PID—CBR-SUP-250G</li> <li>• PID—CBR-CCAP-SUP-160G</li> </ul>	<b>Cisco IOS-XE Release 16.5.1 and Later Releases</b> Cisco cBR-8 CCAP Line Cards: <ul style="list-style-type: none"> <li>• PID—CBR-LC-8D30-16U30</li> <li>• PID—CBR-LC-8D31-16U30</li> <li>• PID—CBR-RF-PIC</li> <li>• PID—CBR-RF-PROT-PIC</li> <li>• PID—CBR-CCAP-LC-40G</li> <li>• PID—CBR-CCAP-LC-40G-R</li> <li>• PID—CBR-CCAP-LC-G2-R</li> <li>• PID—CBR-SUP-8X10G-PIC</li> <li>• PID—CBR-2X100G-PIC</li> </ul> Digital PICs: <ul style="list-style-type: none"> <li>• PID—CBR-DPIC-8X10G</li> <li>• PID—CBR-DPIC-2X100G</li> </ul> Cisco cBR-8 Downstream PHY Module: <ul style="list-style-type: none"> <li>• PID—CBR-D31-DS-MOD</li> </ul> Cisco cBR-8 Upstream PHY Modules: <ul style="list-style-type: none"> <li>• PID—CBR-D31-US-MOD</li> </ul>



**Note** Do not use DPICs (8X10G and 2x100G) to forward IP traffic, as it may cause buffer exhaustion, leading to line card reload.

The only allowed traffic on a DPIC interface is DEPI, UEPI, and GCP traffic from the Cisco cBR-8 router to Remote PHY devices. Other traffic such as DHCP, SSH, and UTSC should flow via another router, since DPICs cannot be used for normal routing.

# Overview of DOCSIS Interfaces and Fiber Node Configurations

The Interface line card used in the Cisco cBR chassis is an integrated line card that has two downstream modules and one upstream module. The line cards support DOCSIS 3.0 features including downstream bonding groups, and upstream bonding groups.

## Downstream Features

Physically, the downstream modules support eight physical connectors or ports. The downstream modules support the following features:

- The downstream modules support eight downstream integrated-cable controllers for these eight ports. Each downstream integrated-cable controller is associated with an RF port.
- Each downstream controller supports up to 128 downstream channels (0-127).
- Each downstream controller supports up to 128 integrated-cable interfaces. Therefore, each line card has 1024 integrated-cable interfaces.
- Each integrated-cable interface has a static mapping to an integrated-cable controller RF channel. For example, Integrated-Cable interface 3/0/0:0 is mapped to RF Channel 0 on Integrated-Cable controller 3/0/0.
- The following table lists the number of downstream DOCSIS channels different Cisco cBR-8 line cards support.

This table lists the number of downstream DOCSIS channels different Cisco cBR-8 line cards support.

**Table 43: Support for Downstream DOCSIS Channels**

Line Card	Downstream DOCSIS Channels
CBR-CCAP-LC-40G	Up to 768
CBR-CCAP-LC-40G-R	Up to 1024
CBR-CCAP-LC-G2-R	Up to 1536



**Note** In Cisco IOS XE Amsterdam 17.3.x and earlier releases, CBR-CCAP-LC-G2-R line card supports up to 768 downstream DOCSIS channels.

- A total of 512 wideband-cable interfaces (downstream bonding groups) may be configured on each line card.
  - Each wideband-cable interface supports a maximum of 64 downstream channels.
  - 128 of the 512 wideband-cable interfaces (downstream bonding groups) may contain 33 or more channels.

## Upstream Features

The Interface line card has one upstream module supporting 16 physical connectors or ports. The upstream features are as follows:

- The line card supports 16 upstream-cable controllers, each mapping to one upstream connector.
- 12 upstream channels can be configured per upstream controller.
- 12 upstream channels can be enabled per pair of upstream controllers.

For more details on the upstream features, see the *Downstream Upstream Guide*.

## MAC Domains (Cable Interfaces)

1. 16 MAC domains (cable interfaces) may be configured per line card.



---

**Note** CBR-CCAP-LC-G2-R line card supports up to 32 MAC domains per line card.

---

2. Maximum of 16 upstream channels can be configured in each MAC domain.
3. A maximum of 255 downstream channels may be added to a MAC domain.
4. Maximum number of primary capable downstream channels per MAC Domain is 32. Non Primary downstream channels are added automatically to the MAC domains when the fiber nodes are configured.

## Fiber Nodes

512 fiber nodes may be configured for each Cisco cBR-8 chassis.

# Configuring DOCSIS Interfaces and Fiber Nodes

## Configuring Upstream Channels

### Verifying the Controller Configuration

Use the **show controllers upstream-cable** command to verify the configuration of the upstream channels in the controllers. Use the modifier **| include upstream** to see the administrative and operational state of the controllers.

```
Router#show controllers upstream-Cable 1/0/0 | include upstream
Controller 1/0/0 upstream 0 AdminState:UP OpState: UP
Controller 1/0/0 upstream 1 AdminState:UP OpState: UP
Controller 1/0/0 upstream 2 AdminState:UP OpState: UP
Controller 1/0/0 upstream 3 AdminState:UP OpState: UP
Controller 1/0/0 upstream 4 AdminState:DOWN Opstate: DOWN (Reason: Default)
Controller 1/0/0 upstream 5 AdminState:DOWN Opstate: DOWN (Reason: Default)
Controller 1/0/0 upstream 6 AdminState:DOWN Opstate: DOWN (Reason: Default)
Controller 1/0/0 upstream 7 AdminState:DOWN Opstate: DOWN (Reason: Default)
Router#
```

## Binding Upstream Channels to MAC Domain

By default, a MAC domain does not contain any upstream channels. This section describes the configurations necessary to bind one or more upstream channels to a MAC domain. Each upstream channel is bound to only one MAC domain. The MAC domain and the upstream channel must reside on the same line card (same slot). If required, the upstream channels within the same upstream controller can be bound to different MAC domains.

### Before you begin

#### Restrictions

- A maximum of 8 upstream channels may be bound to one MAC domain.



**Note** A maximum of 16 upstream channels may be configured in each MAC domain.

- The MAC domain and channels must share the same slot. That is, a MAC Domain may include channels from any controller on the same slot.

### Procedure

	Command or Action	Purpose
Step 1	<b>enable</b> <b>Example:</b> Router> <b>enable</b>	Enables privileged EXEC mode. Enter your password if prompted.
Step 2	<b>configure terminal</b> <b>Example:</b> Router# <b>configure terminal</b>	Enters global configuration mode.
Step 3	<b>interface cable</b> <b>Example:</b> Router# <b>interface cable 1/0/0</b>	Enters MAC Domain configuration mode. Values for slot are 0-3 and 6-9, for subslot is always 0, for MD Index is 0-15.
Step 4	<b>upstream upstream-Cable us-channel</b> <b>Example:</b> Router(config-if) # <b>upstream 4 upstream-Cable 1/0/0 us-channel 7</b>	Binds the specified upstream channel to the MAC Domain.
Step 5	<b>end</b> <b>Example:</b> Router# <b>end</b>	Returns to privileged EXEC mode.

### What to do next

To verify MAC Domain configurations for upstream, use the **show cable mac-domain** command with **egd-associations** keyword.

The MD US Binding table shows the upstream channel binding.

```
Router#show cable mac-domain c1/0/0 cgd-associations
Load for five secs: 1%/0%; one minute: 2%; five minutes: 2%
Time source is NTP, *13:36:26.209 PST Fri Jan 20 2012
CGD Host   Resource   DS Channels           Upstreams   (ALLUS)   Active DS
Ca1/0/0   1/0/0      8                    0-1        Yes       8
           16                    0-1        Yes       16
           24                    0-1        Yes       24
           32-33        0-1        Yes       32-33
           40                    0-1        Yes       40
```

MD US binding:

Host	MD	Controller	US channel	State
Ca1/0/0	U0	1/0/0	0	UP
Ca1/0/0	U1	1/0/0	1	UP
Ca1/0/0	U2	1/0/0	2	UP
Ca1/0/0	U3	1/0/0	3	UP
Ca1/0/0	U4	1/0/1	0	UP
Ca1/0/0	U5	1/0/1	1	UP
Ca1/0/0	U6	1/0/1	2	UP
Ca1/0/0	U7	1/0/1	3	UP

Router#

## Configuring Primary Capable Downstream Channels

### Verifying Downstream Configuration in Controller

Use the **show controller Integrated-Cable** command to verify the status of the downstream channels configured on an Integrated-cable controller.

```
Router# show controller Integrated-Cable 1/0/0 rf-channel 0-127
Chan State Admin Frequency Type Annex Mod srate Interleaver dcid power output
0 UP UP 381000000 DOCSIS B 256 5361 I32-J4 1 32 NORMAL
1 UP UP 387000000 DOCSIS B 256 5361 I32-J4 2 34 NORMAL
2 UP UP 393000000 DOCSIS B 256 5361 I32-J4 3 34 NORMAL
3 UP UP 399000000 DOCSIS B 256 5361 I32-J4 4 34 NORMAL
```

### Configuring Integrated-cable Interface

Configure an integrated-cable interface to prepare a downstream channel for inclusion within a MAC Domain as a primary-capable downstream channel. The interface configuration provides the following advantages:

- It enables the allocation of bandwidth to the downstream channel.
- It enables the control of the administrative state (shut/no shut) of the channel interface.



The time interval required between the shut and no shut administrative states for the same controller is approximately 30 seconds. You must not change the shut and no shut states rapidly without any delay in script or copy-paste. It can generate unexpected errors.

Each integrated-cable interface is mapped statically to an integrated-cable controller RF channel. For example, IC interface 1/0/0:0 is mapped to IC controller 1/0/0 RF channel 0. Similarly, IC interface 1/0/0:1 is mapped to IC controller 1/0/0 RF channel 1.

IC controllers are numbered 0-7 and RF Channels on each controller are numbered 0-127.

### Before you begin

Determine the percentage of bandwidth to allocate to a channel. The bandwidth percentage configured is converted to a committed information rate (CIR) value for the interface. The value is used to admit non-bonded service flows on this channel. For more information, see the *Dynamic Bandwidth Sharing on the Cisco CMTS Router*.

---

#### Step 1 enable

##### Example:

```
Router> enable
```

Enables privileged EXEC mode.

Enter your password if prompted.

#### Step 2 configure terminal

##### Example:

```
Router# configure terminal
```

Enters global configuration mode.

#### Step 3 interface integrated-cable

##### Example:

```
Router(config)# interface integrated-cable 1/0/0:0
```

Enter the integrated-cable interface configuration mode for specified integrated-cable interface.

#### Step 4 cable rf-bandwidth-percent *percentage-number*

##### Example:

```
Router(config-if)# cable rf-bandwidth-percent 30
```

Configures the bandwidth allocation to the specified integrated-cable interface.

#### Step 5 end

##### Example:

```
Router# end
```

Returns to privileged EXEC mode.

---

**What to do next**

The following conditions are used to determine if an IC (Integrated-Cable) interface is up in current software.

- The IC interface is associated to a MD (MAC Domain) interface.
- The MD interface, which the IC interface associated to, is in UP state.
- The IC interface is not configured shut down.
- The IC interface is configured with bandwidth.
- The associated downstream channel within the IC controller is operationally up.

Use the **show interface Integrated-Cable controller** command to verify the status of the specified integrated-cable interface. The State info table provides information to diagnose issues affecting the operational state of the interface.

```
Router# show interface Integrated-Cable 1/0/0:0 controller
Integrated-Cable1/0/0:0 is up, line protocol is up
...
-----
State info (DSNB if and its underlying states)
-----
DSNB IF state : UP
RF Chan state : UP
RF Chan frequency : 381000000
Bandwidth configured on DSNB IF : YES
Inject Header/HW flow creation status : DSNB_IF_SM_UP
MD state (9/0/0) : UP
*DSNB i/f Line State : UP
-----
```

## Binding Primary Capable Downstream Channels to a MAC Domain

After a downstream channel has a properly configured Integrated-cable interface, it may be bound to a MAC Domain as a primary capable channel. The Channel Grouping Domain (CGD) configuration allows specified downstream channels to be bound to a MAC Domain as primary capable channels. Optionally, it also allows downstream channels to be associated with a subset of upstream channels within the MAC domain.

**Before you begin****Restrictions**

- The downstream channel and MAC domain must reside on the same line card (same slot)
- A maximum of 32 primary capable downstream channels may be bound to a single MAC domain.

**Step 1** enable**Example:**

```
Router> enable
```

Enables privileged EXEC mode.

Enter your password if prompted.

**Step 2**    **configure terminal****Example:**

```
Router# configure terminal
```

Enters global configuration mode.

**Step 3**    **interface cable****Example:**

```
Router#interface cable 1/0/0
```

Enters MAC domain configuration mode.

- *slot*—Specifies the chassis slot number of the interface line card. Valid values are 0-3 and 6-9
- *subslot*—Specifies the secondary slot number of the interface line card. Valid subslot is 0.
- *MD index*—Specifies the MAC Domain index number. Valid values are 0-15.

**Step 4**    **downstream Integrated-Cable slot/subslot/port rf-channels grouplist****Example:**

```
Router#downstream Integrated-Cable 1/0/0 rf-channels 1-6
```

Configures the downstream primary capable channels.

- *grouplist*—Specify the range of downstream rf-channels.

**Step 5**    **end****Example:**

```
Router# end
```

Returns to privileged EXEC mode.

**What to do next**

To verify the downstream primary capable channels, use the **show cable mac-domain** command with **cgd-associations** keyword.

```
Router#show cable mac-domain c1/0/0 cgd-associations
Load for five secs: 1%/0%; one minute: 2%; five minutes: 2%
Time source is NTP, *13:36:26.209 PST Fri Jan 20 2012
CGD Host  Resource  DS Channels  Upstreams  (ALLUS)  Active DS
Ca1/0/0   1/0/0          8           0-1        Yes       8
           16           0-1        Yes       16
           24           0-1        Yes       24
           32-33        0-1        Yes       32-33
           40           0-1        Yes       40
```

```

MD US binding:
Host    MD Controller US channel State
Ca1/0/0 U0 1/0/0     0         UP
Ca1/0/0 U1 1/0/0     1         UP
Ca1/0/0 U2 1/0/0     2         UP
Ca1/0/0 U3 1/0/0     3         UP
Ca1/0/0 U4 1/0/1     0         UP
Ca1/0/0 U5 1/0/1     1         UP
Ca1/0/0 U6 1/0/1     2         UP
Ca1/0/0 U7 1/0/1     3         UP

Router#

```

# Configuring MAC Domain Service Groups

## Configuring the Fiber Nodes

A maximum of 512 fiber nodes may be configured per CMTS. A fiber node configured on the CMTS represents one or more matching physical fiber nodes in the HFC plant. The CMTS uses the fiber node configuration to identify the DOCSIS downstream service group (DS-SG) and DOCSIS upstream Service Group (US-SG) of the physical fiber nodes in the plant. The Service Group information is compared with MAC Domain channel configuration to automatically calculate the MAC Domain downstream and upstream service groups (MD-DS-SGs and MD-US-SGs respectively) within the MAC Domains.

The following is required to create a valid fiber node configuration.

- Each fiber node configuration must include at least one downstream controller and one upstream controller.
- Every MAC Domain and Wideband Interface including channels within the fiber node must use the same bundle interface.
- All downstream channels included within the fiber node must be assigned a unique frequency.
- All downstream channels associated with a particular MAC Domain must be assigned a unique DOCSIS channel ID.

If automatic DOCSIS channel ID allocation is preferred over manual DOCSIS channel ID configuration, the **cable downstream-channel-id automatic** command may be used to enable automatic DOCSIS channel ID allocation for the CMTS.

For details, see the *Cisco CMTS Cable Command Reference*.

### Step 1 enable

#### Example:

```
Router> enable
```

Enables privileged EXEC mode.

Enter your password if prompted.

### Step 2 configure terminal

#### Example:

```
Router# configure terminal
```

Enters global configuration mode.

**Step 3** `cable fiber-node id`

**Example:**

```
Router(config)#cable fiber-node 1
Router(config-fiber-node)#
```

Enters cable fiber-node configuration mode to configure a fiber node

- *id*— cable fiber node ID. The valid range is 1-512.

**Step 4** `downstream Integrated-Cable slot/subslot/port`

**Example:**

```
Router(config-fiber-node)#downstream Integrated-Cable 1/0/0
```

Adds the DOCSIS downstream channels within the controller to the fiber node.

**Step 5** `upstream upstream-Cable slot/subslot/port`

**Example:**

```
Router(config-fiber-node)#upstream upstream-Cable 1/0/0
```

Adds the upstream channels within the controller to the fiber node.

**Step 6** `end`

**Example:**

```
Router# end
```

Returns to privileged EXEC mode.

---

### What to do next

To verify the fiber-node configuration use the `show cable fiber-node` command.

```
Router# show cable fiber-node 1
-----
--
Fiber-Node 1
Description: Feed Mac Domain: Cable1/0/0
Channel(s) : downstream Integrated-Cable 1/0/0: 0-3, 32-35, 64-67,
96-99
Channel ID(s): 1 2 3 4 33 34 35 36 65 66 67 68 97 98
99 100
Upstream-Cable 1/0/0
FN Config Status: Configured (status flags = 0x01)
MDD Status: Valid
Router#
```

The output shows the downstream channel IDs configured on a fiber node. It also shows the status of the upstream-cable configured on the fiber node. Further, it shows the status of MAC Domain Descriptor (MDD) messaging.

## Verify MD-DS-SG Channel Membership

Once the fiber node is valid, the MD-DS-SGs within the associated MAC domains will be automatically populated with downstream channels. The MD-DS-SGs will include the active primary downstream channels within the MAC domain as well as non-primary downstream channels automatically associated with the MAC domain through the fiber node configuration. The non-primary channels must be properly configured within the controller (that are operationally up) to be included in MD-DS-SGs

Use the **show cable mac-domain** command with the **downstream-service-group** option to display the MD-DS-SG channel membership.

```
outer#show cable mac-domain c1/0/0 downstream-service-group
Cable MD-DS-SG RF
IF Id Resource Chan Primary Chan
C1/0/0 5 1/0/0 0-3 0-3
          32-35 32-35
          64-67
          96-99
```

To verify that the primary downstream channels are transmitting MAC Management Messages (MMMs) use the **show controller Integrated-Cable counter rf-channel** command.

```
Router#sh controllers Integrated-Cable 7/0/0 counter rf-channel
Controller RF MPEG MPEG MPEG Sync MAP/UCD User QAM
           Chan Packets bps Mbps Packets Packets Mbps Util
           Tx Tx Tx Tx Tx Tx Tx Tx
7/0/0      0 0 0 0 0.00 0 0 00.00 000.00
7/0/0      1 0 0 0 0.00 0 0 00.00 000.00
7/0/0      2 8239954 2475952 02.47 0 0 02.39 006.60
7/0/0      3 85927382 25769779 25.76 0 0 24.94 068.71
7/0/0      4 85927608 25769027 25.76 0 0 24.94 068.71
7/0/0      5 8239088 2474599 02.47 0 0 02.39 006.59
7/0/0      6 8210840 2463770 02.46 0 0 02.38 006.57
7/0/0      7 50103 15040 00.01 0 0 00.01 000.04
7/0/0      8 50103 15040 00.01 0 0 00.01 000.04
```

## Verify MD-US-SG Channel Membership

Use the **show cable mac-domain** command with the **upstream-service-group** option to display the MD-US-SG channel membership.

```
Router#show cable mac-domain c1/0/0 upstream-service-group
Cable MD 1/0/0
US-SG-ID : 5 US-Chan : U0,1,2,3
Primary-DS: 1/0/0:0 US-SG-ID: 5
MDD US-List : U0,1,2,3
MDD Ambiguity : U0,1,2,3
Primary-DS: 1/0/0:1 US-SG-ID: 5
MDD US-List : U0,1,2,3
MDD Ambiguity : U0,1,2,3
Primary-DS: 1/0/0:2 US-SG-ID: 5
MDD US-List : U0,1,2,3
MDD Ambiguity : U0,1,2,3
Primary-DS: 1/0/0:3 US-SG-ID: 5
MDD US-List : U0,1,2,3
MDD Ambiguity : U0,1,2,3
```

# Downstream Bonding Group Configuration

## Configuring Wideband-cable Interface (Downstream Bonding Grouping)

A Wideband-Cable interface forwards bonded traffic in the downstream direction. A set of downstream RF channels is configured under the Wideband interface. Each line card will support up to 512 Wideband interfaces.

Although there is no real relationship between these wideband interfaces and the 8 controllers (ports), there is a convention of dividing the wideband interfaces into groups per controller.

The 512 wideband interfaces are divided among the 8 controllers - 64 interfaces per controller.

You can create a wideband-cable interface to define a downstream bonding group. A downstream bonding group bonds together a set of downstream RF channels. It can only contain the RF channels from the same line card.

Associations between bonding groups and MAC Domains are automatically created. Associations occur when a bonding group channel set is found to be a subset of a MAC Domain Downstream Service Group (MD-DS-SG) within a MAC Domain. The automatic associations will trigger the creation of an RCC that contains the bonding group's channel set within the MAC Domain.

### Before you begin

#### Restrictions:

1. Included downstream channels must be a part of the same line card slot.
2. All the downstream channels must be from the integrated-cable controllers 0-3 or 4-7.

---

#### Step 1 **enable**

##### Example:

```
Router> enable
```

Enables privileged EXEC mode.

Enter your password if prompted.

#### Step 2 **configure terminal**

##### Example:

```
Router# configure terminal
```

Enters global configuration mode.

#### Step 3 **interface wideband-Cable**

##### Example:

```
Router(config)#interface wideband-Cable 1/0/0:1  
Router(config-if)#
```

Enter the wideband-cable interface configuration mode for specified wideband-cable interface.

#### Step 4 **cable bundle *id***

**Example:**

```
Router(config-if)#cable bundle 1
```

Configures the cable bundle id for this wideband-cable interface. The configured cable bundle id must match the cable bundle id configured in associated MAC domains.

- *Bundle number*— cable bundle number. The valid range is 1-255.

**Step 5** `cable rf-channels channel-list grouplist bandwidth-percent percentage-bandwidth`**Example:**

```
Router(config-if)#cable rf-channel channel-list 1-3 bandwidth-percent 10
```

Configures the bandwidth allocation for specified channel-list and includes the channels in the downstream bonding group. Range for channel numbers are 0-127 (<first channel num-last channel num>).

- *grouplist*—Specify the range of downstream rf-channels.

**Step 6** `cable rf-channels controller controller number channel-list grouplist bandwidth-percent percentage-bandwidth`**Example:**

```
Router(config-if)#cable rf-channel controller 1 channel-list 1-3 bandwidth-percent 10
```

Configures the bandwidth allocation for specified channel-list on downstream controllers and includes the channels in the downstream bonding group. Range for channel numbers are 0-127.

- *controller number*—Downstream controller number. The valid numbers are 0-7.
- *grouplist*—Specify the range of downstream rf-channels.

**Step 7** `end`**Example:**

```
Router# end
```

Returns to privileged EXEC mode.

**What to do next**

Verify the Bonding Group Interfaces.

## Verifying the Bonding Group Interfaces

Use **wideband-channel** option of the **show controllers integrated-Cable** command to display bonding group interfaces:

```
Router# show controllers integrated-cable 1/0/0 wideband-channel
Load for five secs: 2%/0%; one minute: 2%; five minutes: 2%
```



```

Time source is NTP, *17:45:51.964 PST Thu Jan 12 2012
WB          BG      Primary
channel    ID      BG
Wideband-Cable1/0/0:0  12289 Yes
Wideband-Cable1/0/0:1  12290 Yes
Wideband-Cable1/0/0:2  12291 Yes
Wideband-Cable1/0/0:3  12292 Yes
Wideband-Cable1/0/0:4  12293 Yes
Wideband-Cable1/0/0:5  12294 Yes
Wideband-Cable1/0/0:6  12295 Yes
Wideband-Cable1/0/0:7  12296 Yes
Wideband-Cable1/0/0:8  12297 Yes
Wideband-Cable1/0/0:9  12298 Yes
Wideband-Cable1/0/0:10 12299 Yes
Wideband-Cable1/0/0:11 12300 Yes
Wideband-Cable1/0/0:12 12301 Yes
Wideband-Cable1/0/0:13 12302 Yes
Wideband-Cable1/0/0:14 12303 Yes
Wideband-Cable1/0/0:15 12304 Yes
Wideband-Cable1/0/0:16 12305 Yes
Wideband-Cable1/0/0:17 12306 Yes
Wideband-Cable1/0/0:18 12307 Yes
Wideband-Cable1/0/0:19 12308 Yes
Wideband-Cable1/0/0:20 12309 Yes
Wideband-Cable1/0/0:21 12310 Yes
Wideband-Cable1/0/0:22 12311 Yes
Wideband-Cable1/0/0:23 12312 Yes
Wideband-Cable1/0/0:24 12313 Yes
Wideband-Cable1/0/0:25 12314 Yes

```

- To display the RF-channel mapping to wideband channels, use **mapping wb-channel** option.

```

Router# show controllers Integrated-Cable 1/0/0 mapping wb-channel 0
Ctrlr  WB      RF      WB %   WB Rem
1/0/0  0          1/0/0:0  40     1
          1/0/0:1  40     1

```

- To display the downstream MAC Domain service groups, use the **dsbg-associations** option of the **show cable mac-domain** command.

```

Router# show cable mac-domain c1/0/0 dsbg-associations
Wi1/0/0:0      Wi1/0/0:1

```

Use the **show interface Wideband-Cable controller** command to verify the bonding group configurations. The State info table shows the downstream bonding group state information.

```

Router#show interface Wideband-Cable 1/0/0:0 controller
Wideband-Cable1/0/0:0 is up, line protocol is up
  Hardware is CMTS WB interface, address is c414.3c17.1dcb (bia c414.3c17.1dcb)
  MTU 1500 bytes, BW 150000 Kbit/sec, DLY 1000 usec,
    reliability 255/255, txload 1/255, rxload 1/255
  Encapsulation MCNS, loopback not set
  Keepalive set (10 sec)
  ARP type: ARPA, ARP Timeout 04:00:00
  Last input never, output never, output hang never
  Last clearing of "show interface" counters never
  Input queue: 0/375/0/0 (size/max/drops/flushes); Total output drops: 0
  Queueing strategy: weighted fair

```

```

Output queue: 0/1000/64/0 (size/max total/threshold/drops)
  Conversations 0/0/256 (active/max active/max total)
  Reserved Conversations 0/0 (allocated/max allocated)
  Available Bandwidth 112500 kilobits/sec
5 minute input rate 0 bits/sec, 0 packets/sec
5 minute output rate 0 bits/sec, 0 packets/sec
  0 packets input, 0 bytes, 0 no buffer
  Received 0 broadcasts (0 multicasts)
  0 runts, 0 giants, 0 throttles
  0 input errors, 0 CRC, 0 frame, 0 overrun, 0 ignored, 0 abort
  0 packets output, 0 bytes, 0 underruns
  0 output errors, 0 collisions, 3 interface resets
  0 unknown protocol drops
  0 output buffer failures, 0 output buffers swapped out

BG controller details
Wi1/0/0:0 BGID: 12289
Member RFIDs:
  Config RFIDs: 12288-12291 Count: 4
  Active RFIDs: 12288-12291 Count: 4
Attribute mask: 0x80000000
-----
State info (DSBG if and its underlying states)
-----
DSBG IF state           : UP
DSBG Member RF chan states : UP (4 out of 4 chans are UP)
DSBG HWID(FCID)         : 0x3800
*DSBG i/f Line State    : UP
-----

DMP Resources
DMP handle       : 0x10000800
-----
DMP BG pool entry details
HW-id  BGid  BGSize  Enabled
-----
0      : 12289 4      1
-----

Bgid  BGecnt  BGaddr  Channels (1023 means invalid/Unused)
0      0      0: 0 1 2 3 1023 1023 1023 1023
BG      Rate  Neg  Pos  LastTS  CurrCr  Pos
0      25000 65535 65535 0 0 N
-----

RFID - JIB chan mapping for active RFIDs: [rfid:jib-chan-no]
[12288:0] [12289:1] [12290:2] [12291:3]

Router#

```

# Upstream Bonding Group Configuration

## Restrictions for Upstream Bonding Groups

- Upstream bonding groups are configured within the MAC Domain interface
- Upstream bonding groups consist of a set of upstream channels that are bonded together.

- A maximum of 16 upstream channels can be configured for each MAC Domain, which are divided into two groups:
  - Group 1: upstream channel 0-7
  - Group 2: upstream channel 8-15

The **upstream bonding-group** should include all the upstream channels either from Group 1 or Group 2 only.

## Configuring Upstream Bonding Groups

### Before you begin

### Procedure

	Command or Action	Purpose
Step 1	<b>enable</b> <b>Example:</b> Router> <b>enable</b>	Enables privileged EXEC mode. Enter your password if prompted.
Step 2	<b>configure terminal</b> <b>Example:</b> Router# <b>configure terminal</b>	Enters global configuration mode.
Step 3	<b>interface cable slot/subslot/MD index</b> <b>Example:</b> Router(config)# <b>interface cable 1/0/0</b>	Enters MAC domain configuration mode. <ul style="list-style-type: none"> <li>• <i>slot</i>—Specifies the chassis slot number of the interface line card. Valid values are 0-3 and 6-9</li> <li>• <i>subslot</i>—Specifies the secondary slot number of the interface line card. Valid subslot is 0.</li> <li>• <i>MD index</i>—Specifies the MAC Domain index number. Valid values are 0-15.</li> </ul>
Step 4	<b>cable upstream bonding-group</b> <b>Example:</b> Router(config-if) # <b>cable upstream bonding-group 7</b> Router(config-upstream-bonding) #	Creates a static upstream bonding group on a MAC Domain.
Step 5	<b>upstream</b> <b>Example:</b> Router(config-upstream-bonding) # <b>upstream 7</b>	Add upstream channels to an upstream bonding group. A maximum of 16 upstream channels can be configured for each MAC Domain, which are divided into two groups: <ul style="list-style-type: none"> <li>• Group 1: upstream channel 0-7</li> <li>• Group 2: upstream channel 8-15</li> </ul>

	Command or Action	Purpose
		The <b>upstream bonding-group</b> should include all the upstream channels either from Group 1 or Group 2 only.
<b>Step 6</b>	<b>end</b>  <b>Example:</b> Router# <b>end</b>	Returns to privileged EXEC mode.

### What to do next

Use the **show interface cable upstream bonding-group** command to display upstream bonding group information.

```
Router#show interface cable 1/0/0 upstream bonding-group
Load for five secs: 1%/0%; one minute: 2%; five minutes: 2%
Time source is NTP, *10:47:17.142 PST Thu Jan 12 2012
```

```
Cable1/0/0: Upstream Bonding Group 1
 0 packets input, 0 octets input
Segments: 0 valid, 0 discarded, 0 lost
Reserved Bandwidth Max : 0 bits/sec
Reserved Bandwidth      : 0 bits/sec
Available Bandwidth     : 46080000 bits/sec
Total Service Flows On This Bonding Group: 0
Cable1/0/0: Upstream Bonding Group 2
 0 packets input, 0 octets input
Segments: 0 valid, 0 discarded, 0 lost
Reserved Bandwidth Max : 0 bits/sec
Reserved Bandwidth      : 0 bits/sec
Available Bandwidth     : 46080000 bits/sec
Total Service Flows On This Bonding Group: 0
Cable1/0/0: Upstream Bonding Group 65536
 0 packets input, 0 octets input
Segments: 0 valid, 0 discarded, 0 lost
Reserved Bandwidth Max : 0 bits/sec
Reserved Bandwidth      : 0 bits/sec
Available Bandwidth     : 15360000 bits/sec
Total Service Flows On This Bonding Group: 0
Cable1/0/0: Upstream Bonding Group 65537
 0 packets input, 0 octets input
Segments: 0 valid, 0 discarded, 0 lost
Reserved Bandwidth Max : 0 bits/sec
Reserved Bandwidth      : 0 bits/sec
Available Bandwidth     : 15360000 bits/sec
Total Service Flows On This Bonding Group: 0
```

```
Router#
```

## Verifying Upstream Bonding Groups

Use the **show cable upstream bonding-group** command.

```
Router#show interface cable 1/0/0 upstream bonding-group
Load for five secs: 1%/0%; one minute: 2%; five minutes: 2%
Time source is NTP, *10:47:17.142 PST Thu Jan 12 2012
```

```

Cable1/0/0: Upstream Bonding Group 1
  0 packets input, 0 octets input
  Segments: 0 valid, 0 discarded, 0 lost
  Reserved Bandwidth Max : 0 bits/sec
  Reserved Bandwidth      : 0 bits/sec
  Available Bandwidth     : 46080000 bits/sec
  Total Service Flows On This Bonding Group: 0
Cable1/0/0: Upstream Bonding Group 2
  0 packets input, 0 octets input
  Segments: 0 valid, 0 discarded, 0 lost
  Reserved Bandwidth Max : 0 bits/sec
  Reserved Bandwidth      : 0 bits/sec
  Available Bandwidth     : 46080000 bits/sec
  Total Service Flows On This Bonding Group: 0
Cable1/0/0: Upstream Bonding Group 65536
  0 packets input, 0 octets input
  Segments: 0 valid, 0 discarded, 0 lost
  Reserved Bandwidth Max : 0 bits/sec
  Reserved Bandwidth      : 0 bits/sec
  Available Bandwidth     : 15360000 bits/sec
  Total Service Flows On This Bonding Group: 0
Cable1/0/0: Upstream Bonding Group 65537
  0 packets input, 0 octets input
  Segments: 0 valid, 0 discarded, 0 lost
  Reserved Bandwidth Max : 0 bits/sec
  Reserved Bandwidth      : 0 bits/sec
  Available Bandwidth     : 15360000 bits/sec
  Total Service Flows On This Bonding Group: 0

Router#

```

## Additional References

### Technical Assistance

Description	Link
<p>The Cisco Support website provides extensive online resources, including documentation and tools for troubleshooting and resolving technical issues with Cisco products and technologies.</p> <p>To receive security and technical information about your products, you can subscribe to various services, such as the Product Alert Tool (accessed from Field Notices), the Cisco Technical Services Newsletter, and Really Simple Syndication (RSS) Feeds.</p> <p>Access to most tools on the Cisco Support website requires a Cisco.com user ID and password.</p>	<p><a href="http://www.cisco.com/support">http://www.cisco.com/support</a></p>

# Feature Information for DOCSIS Interface and Fiber Node Configuration

Use Cisco Feature Navigator to find information about the platform support and software image support. Cisco Feature Navigator enables you to determine which software images support a specific software release, feature set, or platform. To access Cisco Feature Navigator, go to the <https://cfnng.cisco.com/> link. An account on the Cisco.com page is not required.



**Note** The following table lists the software release in which a given feature is introduced. Unless noted otherwise, subsequent releases of that software release train also support that feature.

*Table 44: Feature Information for DOCSIS Interface and Fiber Node Configuration*

Feature Name	Releases	Feature Information
DOCSIS Interface and Fiber Node Configuration	Cisco IOS XE Everest 16.6.1	This feature was integrated into Cisco IOS XE Everest 16.6.1 on the cisco cBR Series Converged Broadband Routers.
Display QAM Utilization Percentage using the <b>sh controllers Integrated-Cable 7/0/0 counter rf-channel</b>	Cisco IOS XE Gibraltar 16.10.1f	This feature was integrated on the Cisco cBR Series Converged Broadband Routers.



# Service Group Based Configuration of the Cisco cBR Router

---

- [Service Group Profile Based Configuration](#), on page 243
- [Service Profile Configuration for 16x8 with One MAC Domain](#), on page 245
- [Service Profile Configuration for 16x8 with Two MAC Domains](#), on page 247
- [MAC-Domain Split Configuration](#), on page 249

## Service Group Profile Based Configuration

The [DOCSIS Interface and Fiber Node Configuration](#) guide describes the interface and fiber node configurations that are required to operationalize the Cisco cBR router. The steps described to accomplish the tasks involved in such configuration are complex.

To simplify and speed up the process of configuring the physical and logical interfaces required to deploy the Cisco cBR router quickly, a service group (SG) profile based approach is adopted. This document describes the simplified SG profile approach.

This approach provides the following advantages:

- Improves and simplifies the deployment of Cisco cBR router.
- Improves and simplifies the configuration of Cisco cBR Router by eliminating duplicate configurations.
- Improves and simplifies troubleshooting of Cisco cBR router.
- Supports faster Converged Cable Access Platform (CCAP) provisioning by using common and quick replication across nodes and regions.

To configure the interfaces and quickly operationalize the Cisco cBR router, a set of common profiles are created and are created and configured into global service group profiles. These global service group profiles may be applied to fiber node interfaces along with a mapping of the service group interfaces to the physical interfaces.

Common profiles are profiles which contain configurations for common service group (SG) interfaces like MAC domain, wideband-cable, and primary downstream

The common profiles and the global SG profiles may be independent of the topology of the network in which they are applied. The SG interface to physical interface mapping defines the behavior of the profiles in the topology that the SG profiles have been applied to.

**Limitations:**

- A common profile cannot be deleted if it is associated with the fiber nodes. It can be modified by entering the profile configuration mode using the **cable profile** command.
- A service-group profile cannot be deleted or modified if it is associated with the fiber nodes.
- To associate a new global SG profile to a fiber node, dissociate the currently associated global SG profile from the fiber node.
- To configure for a unique topology, use the full configuration approach provided in [DOCSIS Interface and Fiber Node Configuration](#) guide.
- When the secondary line card is in active mode, the following limitations apply:
  - A MAC domain, Wideband-Cable interface, downstream channel, and SG profile cannot be modified when they are associated with the fiber nodes.
  - SG profile cannot be dissociated from the fiber nodes.
  - A MAC domain, Wideband-Cable interface, downstream channel, and SG profile can be created but cannot be associated to the fiber node.
  - To enable the SG operation simplification feature, auto-reset feature must be enabled using the **cable wideband auto-reset** command.
- Do not support downgrade cBR-8 image from 16.7.x to previous image if the configuration includes mac domain split configuration.

Broadly, the following steps define and deploy the common profiles and the SG profiles:

1. Define and configure the Common profiles: The SG interface profiles or the common profiles contain configuration parameters common to a group of similar interfaces. For example, a profile may contain specific configuration parameters shared by multiple Wideband-Cable interfaces, associated across multiple line cards. A common profile is configured at the global or chassis level. All interfaces associated with a profile will inherit the configuration in the profile. Any common profile may be associated with any global SG profile. Use the **cable profile** *profile-type profile-name* command to define the following common profiles:
  - MAC Domain (MD) profile
  - Primary Downstream channel (DS) profile
  - Wideband-cable Interface (WB) profile
  - Global Service Group (SG) profile
2. Complete the following configurations to the fiber node interface using the **cable fiber-node** command:
  - Define the downstream and upstream ports. Map the appropriate interface-cable using the **downstream interface-cable** command. Map the appropriate upstream-cable interface using the **upstream upstream-cable** command.
  - Use the **downstream sg-channel** command to map the logical downstream SG channels to the physical RF channels and the **upstream sg-channel** command to map the logical upstream SG channels to the physical upstream channels.
  - Use the **service-group profile** to associate the global service group profile to the fiber node.



See the use case scenarios for configurations and examples.

## Service Profile Configuration for 16x8 with One MAC Domain

This section describes the service group based configurations for a 16x8 service group with one MAC domain.

### Step 1 `cable profile profile-type profile-name`

For MAC Domain profile, specify *profile-type* as **mac-domain**.

```
Router(config)#cable profile mac-domain MD1
Router(config-profile-md)#cable dynamic-secret mark
Router(config-profile-md)#cable shared-secret 0 cisco
Router(config-profile-md)#cable ip-init ipv4
Router(config-profile-md)#cable mtc-mode
Router(config-profile-md)#cable mrc-mode
Router(config-profile-md)#cable privacy mandatory
Router(config-profile-md)#cable privacy bpi-plus-policy
```

For Primary downstream profile, specify *profile-type* as **downstream**.

```
Router(config)#cable profile downstream DS1
Router(config-profile-ds)#cable rf-bandwidth-percent 20
Router(config-profile-ds)#cable attribute-mask 0x80000000
```

For wideband-cable interface profile, specify *profile-type* as **wideband-interface**.

```
Router(config)#cable profile wideband-interface BG1
Router(config-profile-wb)#cable downstream attribute-mask 0x80000000
```

For global service group profile, specify *profile-type* as **service-group**. In the service group profile, configure the cable bundle associated, mac-domain profile, and the wideband interface profile

```
Router(config)#cable profile service-group SG-16x8-1_1
Router(config-profile-sg)#cable bundle 71
Router(config-profile-sg)#mac-domain 0 profile mdl
Router(config-profile-sg-md)#downstream sg-channel 0-7 profile ds1 upstream 0-3
Router(config-profile-sg-md)#upstream 0 sg-channel 0
Router(config-profile-sg-md)#upstream 1 sg-channel 1
Router(config-profile-sg-md)#upstream 2 sg-channel 2
Router(config-profile-sg-md)#upstream 3 sg-channel 3
Router(config-profile-sg-md)#upstream 4 sg-channel 4
Router(config-profile-sg-md)#upstream 5 sg-channel 5
Router(config-profile-sg-md)#upstream 6 sg-channel 6
Router(config-profile-sg-md)#upstream 7 sg-channel 7
Router(config-profile-sg-md)#us-bonding-group 1
Router(config-profile-sg-md-usbg)#upstream 0
Router(config-profile-sg-md-usbg)#upstream 1
Router(config-profile-sg-md-usbg)#upstream 2
Router(config-profile-sg-md-usbg)#upstream 3
Router(config-profile-sg-md-usbg)#upstream 4
Router(config-profile-sg-md-usbg)#upstream 5
Router(config-profile-sg-md-usbg)#upstream 6
```

```

Router(config-profile-sg-md-usbg) #upstream 7
Router(config-profile-sg-md-usbg) #attributes 8000000
Router(config-profile-sg-md-usbg) #exit
Router(config-profile-sg-md) #exit
Router(config-profile-sg) #

Router(config-profile-sg) #wideband-interface 1 profile BG1
Router(config-profile-sg-bg) #downstream sg-channel 0 15 rf-bandwidth-percent 10
Router(config-profile-sg-bg) #end
Router#

```

## Step 2 cable fiber-node

Enter fiber-node configuration mode. Configure the following in fiber-node configuration mode:

- downstream port
- upstream port
- downstream sg-channels to rf-channels mapping
- upstream sg-channels to us-channels mapping
- global service group mapping
- managed MAC domain

```

Router(config) #cable fiber-node 1
Router(config-fiber-node) #downstream integrated-cable 3/0/0
Router(config-fiber-node) #upstream upstream-cable 3/0/0
Router(config-fiber-node) #downstream sg-channel 0 15 integrated-cable 3/0/0 rf-channel 0 15
Router(config-fiber-node) #upstream sg-channel 0 7 upstream-cable 3/0/0 us-channel 0 7
Router(config-fiber-node) #service-group profile SG-16X8-1_1

```

### What to do next

Use the **show cable fiber-node [id] mapping** and the **show cable fiber-node [id] derived** commands to check the configuration of the interfaces.

```

Router#show cable fiber-node 1 mapping
Fiber-node 1:
Upstream:
Sg chan      Us-chan      Op state
0            3/0/0 0      Up
1            3/0/0 1      Up
2            3/0/0 2      Up
3            3/0/0 3      Up
4            3/0/0 4      Up
5            3/0/0 5      Up
6            3/0/0 6      Up
7            3/0/0 7      Up
Downstream:
Sg chan      Ds-rf-chan   Op state
0            3/0/0:0     Up
1            3/0/0:1     Up
2            3/0/0:2     Up

```

```

3          3/0/0:3      Up
4          3/0/0:4      Up
5          3/0/0:5      Up
6          3/0/0:6      Up
7          3/0/0:7      Up
8          3/0/0:8      Up
9          3/0/0:9      Up
10         3/0/0:10     Up
11         3/0/0:11     Up
12         3/0/0:12     Up
13         3/0/0:13     Up
14         3/0/0:14     Up
15         3/0/0:15     Up

```

```

Router#show cable fiber-node 1 derived
Fiber-node 1:
          interface          Assoc succeeded
mac-domain 0  Cable3/0/0      Y
Wideband 1   Wideband-Cable3/0/0:0  Y
Router#

```

Use the **show cable mac-domain fiber-node** command to verify the interface associations.

```

Router#show cable mac-domain fiber-node 1 md 0 downstream-service-group
Cable   MD-DS-SG          RF
IF      Id              Resource   Chan    Primary Chan
C3/0/0
Router#

```

```

Router#show cable mac-domain fiber-node 1 md 0 upstream-service-group
Cable MD 3/0/0
Router#

```

## Service Profile Configuration for 16x8 with Two MAC Domains

This section describes the service group based configurations for a 16x8 service group with two MAC domains, split downstream and overlaid upstream channels.

### Step 1 **cable profile** *profile-type profile-name*

For MAC Domain profile, specify *profile-type* as **mac-domain**.

```

Router(config)#cable profile mac-domain MD1
Router(config-profile-md)#cable dynamic-secret mark
Router(config-profile-md)#cable shared-secret 0 cisco
Router(config-profile-md)#cable ip-init ipv4
Router(config-profile-md)#cable mtc-mode
Router(config-profile-md)#cable mrc-mode
Router(config-profile-md)#cable privacy mandatory
Router(config-profile-md)#cable privacy bpi-plus-policy

```

For Primary downstream profile, specify *profile-type* as **downstream**.

```
Router(config)#cable profile downstream DS1
Router(config-profile-ds)#cable rf-bandwidth-percent 20
Router(config-profile-ds)#cable attribute-mask 0x80000000
```

For wideband-cable interface profile, specify *profile-type* as **wideband-interface**.

```
Router(config)#cable profile wideband-interface BG1
Router(config-profile-wb)#cable downstream attribute-mask 0x80000000
```

For global service group profile, specify *profile-type* as **service-group**. In the service group profile, configure the cable bundle associated, mac-domain profile, and the wideband interface profile

```
Router(config)#cable profile service-group SG-16x4-1_2
Router(config-profile-sg)#cable bundle 71
Router(config-profile-sg)#mac-domain 0 profile mdl
Router(config-profile-sg-md)#downstream sg-channel 0-15 profile dsl upstream 0-3
Router(config-profile-sg-md)#upstream 0 sg-channel 0
Router(config-profile-sg-md)#upstream 1 sg-channel 1
Router(config-profile-sg-md)#upstream 2 sg-channel 2
Router(config-profile-sg-md)#upstream 3 sg-channel 3
Router(config-profile-sg-md)#us-bonding-group 1
Router(config-profile-sg-md-usbg)#upstream 0
Router(config-profile-sg-md-usbg)#upstream 1
Router(config-profile-sg-md-usbg)#upstream 2
Router(config-profile-sg-md-usbg)#upstream 3
Router(config-profile-sg-md-usbg)#exit
Router(config-profile-sg-md)#exit
Router(config-profile-sg)#

Router(config-profile-sg)#wideband-interface 1 profile BG1
Router(config-profile-sg-bg)#downstream sg-channel 0 7 rf-bandwidth-percent 10
Router(config-profile-sg-bg)#exit
Router(config-profile-sg)#wideband-interface 2 profile BG1
Router(config-profile-sg-bg)#downstream sg-channel 8 15 rf-bandwidth-percent 10
Router#
```

## Step 2 cable fiber-node

Enter fiber-node configuration mode. Configure the following in fiber-node configuration mode:

- downstream port
- upstream port
- downstream sg-channels to rf-channels mapping
- upstream sg-channels to us-channels mapping
- global service group mapping
- managed MAC domain

```
Router(config)#cable fiber-node 1
Router(config-fiber-node)#downstream integrated-cable 3/0/0
Router(config-fiber-node)#upstream upstream-cable 3/0/0
Router(config-fiber-node)#downstream sg-channel 0 7 integrated-cable 3/0/0 rf-channel 0 15
Router(config-fiber-node)#upstream sg-channel 0 3 upstream-cable 3/0/1 us-channel 0 3
```

```
Router(config-fiber-node)#service-group profile SG-16X4-1_2
Router(config-fiber-node)#exit
Router(config)#
```

```
Router(config)#cable fiber-node 2
Router(config-fiber-node)#downstream integrated-cable 3/0/0
Router(config-fiber-node)#upstream upstream-cable 3/0/1
Router(config-fiber-node)#downstream sg-channel 0 7 integrated-cable 3/0/0 rf-channel 8 15
Router(config-fiber-node)#downstream sg-channel 8 15 integrated-cable 3/0/0 rf-channel 0 7
Router(config-fiber-node)#upstream sg-channel 0 3 upstream-cable 3/0/1 us-channel 0 3
Router(config-fiber-node)#service-group profile SG-16X4-1_2
Router(config-fiber-node)#exit
Router(config)#
```

---

### What to do next

Use the **show cable fiber-node [id] mapping** and the **show cable fiber-node [id] derived** commands to check the configuration of the interfaces.

## MAC-Domain Split Configuration

This section describes the MAC-domain split configurations.



### Note

- In MAC domain split scenario, we must configure upstream peer-node-us and managed MAC domain.
  - After a fiber node managed MAC domain, we will reserve cable interface by **cable managed fiber-node** command.
  - If a fiber-node has peer, we can not add managed MAC domain.
  - If a fiber-node has peer, we can not modify the configuration of channel mapping and upstream peer-node-us
  - If a fiber-node has managed MAC domain, we can not remove upstream peer-node-us.
  - Only both two fiber-nodes are associated with service group profile, mac-domains and wideband interfaces will be generated.
  - MAC domain and wideband interfaces will be removed as soon as one fiber-node is unassociated with service group profile.
- 

### Step 1 cable profile mac-domain

Define global common profiles for MAC-domain, bonding group, primary downstream.

```
Router(config)#cable profile mac-domain MD
```

```

Router(config-profile-md)#load-interval 30
Router(config-profile-md)#cable dynamic-secret mark
Router(config-profile-md)#cable shared-secret 0 cisco
Router(config-profile-md)#cable ip-init ipv4
Router(config-profile-md)#cable mtc-mode
Router(config-profile-md)#cable mrc-mode
Router(config-profile-md)#cable privacy mandatory
Router(config-profile-md)#cable privacy bpi-plus-policy
Router(config-profile-md)#cable privacy accept-self-signed-certificate
Router(config-profile-md)#cable privacy dsx-support
Router(config-profile-md)#cable privacy eae-policy capability-enforcement
Router(config-profile-md)#cable privacy kek life-time 300
Router(config-profile-md)#cable privacy retain-failed-certificates
Router(config-profile-md)#cable privacy skip-validity-period
Router(config-profile-md)#cable privacy tek life-time 180
Router(config-profile-md)#cable cm-status enable 3
Router(config-profile-md)#cable map-advance dynamic
Router(config-profile-md)#cable upstream 0 attribute-mask FFFFFFFF
Router(config-profile-md)#cable upstream 0 power-adjust continue 5
Router(config-profile-md)#cable upstream balance-scheduling
Router(config)#cable profile downstream DS
Router(config-profile-ds)#cable rf-bandwidth-percent 20
Router(config-profile-ds)#cable attribute-mask 0x80000000
Router(config)#cable profile wideband-interface BG
Router(config-profile-wb)#cable downstream attribute-mask 0x80000000
Router(config-profile-wb)#description BG
Router(config-profile-wb)#load-interval 30

```

## Step 2 cable profile service-group

In the service group profile, configure the cable bundle associated, mac-domain profile, and the wideband interface profile.

```

Router(config)#cable profile service-group MD_SPLIT
Router(config-profile-sg)#cable bundle 1
Router(config-profile-sg)#mac-domain 0 profile MD
Router(config-profile-sg-md)#downstream sg-channel 0-15 profile DS
Router(config-profile-sg-md)#upstream 0 sg-channel 0
Router(config-profile-sg-md)#upstream 1 sg-channel 1
Router(config-profile-sg-md)#upstream 2 sg-channel 2
Router(config-profile-sg-md)#upstream 3 sg-channel 3
Router(config-profile-sg-md)#upstream 4 sg-channel 4
Router(config-profile-sg-md)#upstream 5 sg-channel 5
Router(config-profile-sg-md)#upstream 6 sg-channel 6
Router(config-profile-sg-md)#upstream 7 sg-channel 7
Router(config-profile-sg-md)#us-bonding-group 1
Router(config-profile-sg-md-usbg)#upstream 0
Router(config-profile-sg-md-usbg)#upstream 1
Router(config-profile-sg-md-usbg)#upstream 2
Router(config-profile-sg-md-usbg)#upstream 3
Router(config-profile-sg-md-usbg)#attributes 8000000
Router(config-profile-sg-md-usbg)#exit
Router(config-profile-sg-md)#us-bonding-group 2
Router(config-profile-sg-md-usbg)#upstream 4
Router(config-profile-sg-md-usbg)#upstream 5
Router(config-profile-sg-md-usbg)#upstream 6
Router(config-profile-sg-md-usbg)#upstream 7
Router(config-profile-sg-md-usbg)#attributes 8000000
Router(config-profile-sg-md-usbg)#exit
Router(config-profile-sg-md)#exit
Router(config-profile-sg)#wideband-interface 0 profile WB
Router(config-profile-sg-bg)#downstream sg-channel 0 7 rf-bandwidth-percent 1
Router(config-profile-sg-bg)#exit
Router(config-profile-sg)#wideband-interface 1 profile WB

```

```
Router(config-profile-sg-bg)#downstream sg-channel 8 15 rf-bandwidth-percent 1
```

### Step 3 cable fiber-node

Enter fiber-node configuration mode. Configure the following in fiber-node configuration mode:

- downstream port
- upstream port
- downstream sg-channels to rf-channels mapping
- upstream sg-channels to us-channels mapping
- abstract upstream channel
- managed MAC domain
- global service group mapping

```
Router(config)#cable fiber-node 67
Router(config-fiber-node)#downstream integrated-cable 6/0/6
Router(config-fiber-node)#upstream upstream-cable 6/0/6
Router(config-fiber-node)#downstream sg-channel 0 15 integrated-cable 6/0/6 rf-channel 0
15
Router(config-fiber-node)#upstream sg-channel 0 3 upstream-cable 6/0/6 us-channel 0 3
Router(config-fiber-node)#upstream sg-channel 4 7 peer-node-us
Router(config-fiber-node)#service-group managed md 0 cable6/0/6
Router(config-fiber-node)#service-group profile MD_SPLIT
```

```
Router(config)#cable fiber-node 69
Router(config-fiber-node)#downstream integrated-cable 6/0/6
Router(config-fiber-node)#upstream upstream-cable 6/0/1
Router(config-fiber-node)#downstream sg-channel 0 15 integrated-cable 6/0/6 rf-channel 0
15
Router(config-fiber-node)#upstream sg-channel 4 7 upstream-cable 6/0/1 us-channel 0 3
Router(config-fiber-node)#upstream sg-channel 0 3 peer-node-us
Router(config-fiber-node)#service-group managed md 0 cable6/0/6
Router(config-fiber-node)#service-group profile MD_SPLIT
```

---







## CHAPTER 17

# DOCSIS Load Balancing Groups

---

**First Published:** April 11, 2015

Support for the restricted load balancing group (RLBG)/general load balancing group (GLBG) is based on DOCSIS 3.0 specifications.

Your software release may not support all the features that are documented in this module. For the latest feature information and caveats, see the release notes for your platform and software release. The Feature Information Table at the end of this document provides information about the documented features and lists the releases in which each feature is supported.

Use Cisco Feature Navigator to find information about platform support and Cisco software image support. To access Cisco Feature Navigator, go to <http://tools.cisco.com/ITDIT/CFN/>. An account on <http://www.cisco.com/> is not required.

### Contents

- [Hardware Compatibility Matrix for the Cisco cBR Series Routers, on page 253](#)
- [Prerequisites for DOCSIS Load Balancing Groups, on page 255](#)
- [Restrictions for DOCSIS Load Balancing Groups, on page 255](#)
- [Information About DOCSIS Load Balancing Groups, on page 256](#)
- [How to Configure DOCSIS Load Balancing Groups, on page 262](#)
- [Configuration Examples for DOCSIS Load Balancing Groups, on page 272](#)
- [How to Configure Load Balancing with Operational Simplification, on page 273](#)
- [Verifying DOCSIS Load Balancing Groups, on page 277](#)
- [Additional References, on page 282](#)
- [Feature Information for DOCSIS Load Balancing Groups, on page 282](#)

## Hardware Compatibility Matrix for the Cisco cBR Series Routers



---

**Note** The hardware components that are introduced in a given Cisco IOS-XE Release are supported in all subsequent releases unless otherwise specified.

---

Table 45: Hardware Compatibility Matrix for the Cisco cBR Series Routers

Cisco CMTS Platform	Processor Engine	Interface Cards
Cisco cBR-8 Converged Broadband Router	<p><b>Cisco IOS-XE Release 16.5.1 and Later Releases</b></p> <p>Cisco cBR-8 Supervisor:</p> <ul style="list-style-type: none"> <li>• PID—CBR-SUP-250G</li> <li>• PID—CBR-CCAP-SUP-160G</li> </ul>	<p><b>Cisco IOS-XE Release 16.5.1 and Later Releases</b></p> <p>Cisco cBR-8 CCAP Line Cards:</p> <ul style="list-style-type: none"> <li>• PID—CBR-LC-8D30-16U30</li> <li>• PID—CBR-LC-8D31-16U30</li> <li>• PID—CBR-RF-PIC</li> <li>• PID—CBR-RF-PROT-PIC</li> <li>• PID—CBR-CCAP-LC-40G</li> <li>• PID—CBR-CCAP-LC-40G-R</li> <li>• PID—CBR-CCAP-LC-G2-R</li> <li>• PID—CBR-SUP-8X10G-PIC</li> <li>• PID—CBR-2X100G-PIC</li> </ul> <p>Digital PICs:</p> <ul style="list-style-type: none"> <li>• PID—CBR-DPIC-8X10G</li> <li>• PID—CBR-DPIC-2X100G</li> </ul> <p>Cisco cBR-8 Downstream PHY Module:</p> <ul style="list-style-type: none"> <li>• PID—CBR-D31-DS-MOD</li> </ul> <p>Cisco cBR-8 Upstream PHY Modules:</p> <ul style="list-style-type: none"> <li>• PID—CBR-D31-US-MOD</li> </ul>



**Note** Do not use DPICs (8X10G and 2x100G) to forward IP traffic, as it may cause buffer exhaustion, leading to line card reload.

The only allowed traffic on a DPIC interface is DEPI, UEPI, and GCP traffic from the Cisco cBR-8 router to Remote PHY devices. Other traffic such as DHCP, SSH, and UTSC should flow via another router, since DPICs cannot be used for normal routing.

## Prerequisites for DOCSIS Load Balancing Groups

DOCSIS Load Balancing Groups including Restricted/General Load Balancing groups with Downstream Dynamic Load Balancing feature has the following prerequisites:

- A RLBG and a DOCSIS 2.0 GLBG should have a load balancing group (LBG) ID.
- A LBG should have a default policy ID.
- During registration, a cable modem (CM) that has been assigned to a LBG must also be assigned a policy ID and priority, through Simple Network Management Protocol (SNMP), the cable modem configuration file, or Cisco Cable Modem Termination System (CMTS) configuration.
- The cable modem must send service type identifier (STID), service class name, and DOCSIS version and capability type/length/value (TLV) settings to the Cisco CMTS for registration if the fields are used by general tagging.

## Restrictions for DOCSIS Load Balancing Groups

The DOCSIS Load Balancing Groups (LBG) including RLBG/GLBG Support with DLB Support feature has the following restrictions:

- A maximum of 256 DOCSIS policies and 256 rules per chassis are supported.
- Cross-line card (LC) configuration or moving of cable modems is not supported.
- When deployed with channel restriction features, if the target upstream channel attribute masks are against that of the cable modem, then the cable modem on the higher load upstream will not be load balanced, as the current load balancing moves cable modems only to the target upstream. However, cable modems that do not have an attribute mask can still be load balanced. You should consider the following while deploying the load balancing groups: the target upstream will always be the upstream that has the lowest load. If some other upstreams have the same load, the upstream with the lowest index will be chosen as the target upstream.
- We recommend all LBGs that share channels must use the same LB method.

The DOCSIS LBG with RLBG/GLBG Support and DLB Support feature have the following cross functional restrictions:

- Cable modems operating in the multiple transmit channel (MTC) mode do not register for a RLBG assignment, even if their configuration file contains relevant TLVs, such as STID and LBG ID. However, cable modems operating in the multiple receive channel (MRC) can register for a RLBG assignment.
- The Cisco CMTS can parse a specific TLV encoded in cable modem configuration file, and prohibit any DCC operation on the cable modems.
- DOCSIS MAC domain downstream service group (MD-DS-SG) channels in MDD messages are incorrect when a combination of channels from multiple line card types are placed in the same fiber node.

In a complex fiber node setup, with channels from more than one line card, or downstream channels of one MAC domain in more than one fiber node, some modems may not come w-online (wideband online). If a MAC domain has more than one MD-DS-SG, the MDD will contain more than one MD-DS-SG and cause the modem to perform downstream ambiguity resolution. When the modem analyzes the downstream channels from the other line card, it will not see MDD packets and disqualify the channel and the MD-DS-SG. The modem then sends a requested MD-DS-SG of 0 to the CMTS implying it will not participate in a bonding group.

Use the **show cable mac-domain downstream-service-group** command to see the channels in the same MD-DS-SG.

The DOCSIS LBG with RLBG/GLBG Support and DLB Support feature have the following scaling limitations:

- The total number of RLBGs and DOCSIS 2.0 GLBGs cannot exceed 256.
- The total number of tags in a Cisco CMTS cannot exceed 256.
- The total number of DOCSIS 3.0 GLBGs is bounded by free memory.
- A cable modem reset occurs if a CM moves from one cable interface to another because DCC init-tech 0 resets a cable modem during a LB move. A cable modem also resets if the two cable interfaces have been configured with a mismatched **cable ip-init** command.

## Information About DOCSIS Load Balancing Groups

The DOCSIS 2.0 “Autonomous Load Balancing” specification is CM-centric, allowing a channel (US or DS) to be part of multiple RLBGs. Therefore, with the DOCSIS 2.0 specifications, you can decide on which channel the CM can be load balanced.

To configure the Restricted/General Load Balancing and Narrowband Dynamic Bandwidth Sharing with Downstream Dynamic Load Balancing feature, you should understand the following concepts:

### Service-Based Load Balancing

Using the DOCSIS 3.0 modem-based load balancing specifications, you can manage the LB activity on a per-modem basis as follows:

1. Modem to RLBG association through STID
2. Modem to RLBG association through LBG ID
3. Per-modem LB policy assignment
4. Per-modem LB priority assignment
5. Per-modem channel restriction

Implementing the DOCSIS 3.0 modem-based LB specifications enables the Cisco CMTS to provide an advanced service-based LB. The service-based LB can be used to alleviate the burden for the modem-based provisioning and provide the operator an ability to selectively control LB activity based on modem service type. For example, for LB purposes modems can be classified based on:

- Device type
- DOCSIS version
- Service class

The results of the classification can then be used to selectively control the modem LB activity by mapping the modem to the following settings:

- LBG
- Policy

With the service-based LB enabled, existing service-based cable modem segregation features and channel restriction become special cases and can be handled within the same LB framework.

#### Functionality

The Cisco CMTS functions in the following ways for general tagging and service-based LB:

- The Cisco CMTS can classify some modems with user-defined modem classifiers using the STID, service class name, DOCSIS version and capability TLVs and MAC Organization Unique Identifier (OUI).
- Each modem classifier has a unique tag. The Cisco CMTS allows each modem to carry one tag. When multiple tags match one cable modem, the tag that has the least index gets applied on the cable modems.
- The Cisco CMTS classifies a CM and assigns a tag, and if a RLBG with that tag is configured, the CM gets assigned to that RLBG.
- The Cisco CMTS can match multiple tags to a RLBG and a DOCSIS policy.
- On the Cisco CMTS, a user can configure whether the general tagging overrides the RLBG or DOCSIS policy assignment using TLVs in the CM configuration file and SNMP when a conflict occurs.
- When doing autonomous LB, the Cisco CMTS ensures that the target channels are available to a specific CM with regard to admission control, the SF attribute masks, and CM attribute masks.
- The user can configure the number of times that a DCC fails a CM before the CM is removed from dynamic LB on the Cisco CMTS.
- The user can configure DCC initialization techniques or whether to use Upstream Channel Change (UCC) for a LBG or for a particular source and target pair on the Cisco CMTS. However, DCC is not issued to cable modems provisioned in DOCSIS 1.0 mode. By default, the UCC for a LBG is not configured and therefore, all channel changes are done through DCC.
- The Cisco CMTS supports LB on at least one logical channel on a physical US channel that has multiple logical US channels.
- As per the DOCSIS 3.0 specifications, a lower load balancing priority indicates a higher likelihood that a CM will be moved due to load balancing operations.
- You can create a policy to set the lower bandwidth for CMs. the LBG can only move cable modems with throughput that is above the threshold.

### Compatibility

Both downstream and upstream autonomous load balancing is supported for single channel cable modems.

## RLBG/GLBG Assignment

The user can configure one or more service type IDs for each RLBG. The user can also configure the Cisco CMTS, using CLI or SNMP, to restrict a particular cable modem to a certain STID and RLBG ID. However, if such a configuration is made, both the STID and RLBG ID in the configuration file are ignored by the Cisco CMTS.

When the STID is configured by CLI or SNMP or the STID is present in the cable modem configuration file, the Cisco CMTS selects an upstream and downstream channel, which offers the signaled service type, from a RLBG, if such channels exist. However, if an upstream and downstream channel do not exist that provide the signaled service type the Cisco CMTS assigns an upstream and downstream channel that does not offer the signaled service type.

When the LBG ID is configured by CLI or SNMP or the LBG ID is present in the cable modem configuration file, the Cisco CMTS examines the available choices for upstream and downstream channels and, if they include a channel pair associated with the signaled LBG, the Cisco CMTS assigns the cable modem to the signaled LBG. If these conditions are not met, the Cisco CMTS disregards the LBG ID.

If there are multiple upstream and downstream channels available that meet the requirements of the STID, if present, and the LBG ID, if present, the Cisco CMTS selects an upstream and/or downstream channel that meet the cable modem required and forbidden attribute masks requested in the configuration file. If upstream and downstream channels are not available that meet these criteria, the Cisco CMTS can disregard the cable modem attribute masks and select an alternative upstream and/or downstream channel.

In determining a target channel pair for a cable modem during registration time, the Cisco CMTS tries to find the target channel pair that can actually reach the cable modem by checking the current channel pair, the MD-DS-SG-ID (Media Access Control Domain Downstream Service Group Identifier) of cable modem (CM-DS-SG-ID) and the MD-US-SG-ID (Media Access Control Domain Upstream Service Group Identifier) of cable modem (CM-US-SG-ID), if present, and fiber node (FN) configurations. If the target channel pair is available to the cable modem and is different from the current channel pair, the Cisco CMTS is required to move the CM by means of DCC technique 0 or downstream frequency override (DFO).

When the Cisco CMTS identifies multiple candidate RLBGs for a CM, but cannot determine which fiber node configuration the cable modem is actually wired to, or cannot determine if the wired RLBG is unusable (when interfaces in the load balance group are disabled or in an administratively down state), the Cisco CMTS assigns the cable modem to the RLBG with the lowest group index. This assignment causes the Cisco CMTS to attempt to move the cable modem to interfaces it is not physically connected to, resulting in service outages for the CM.

The Cisco CMTS enforces fiber node checking during RLBG assignment.

The Cisco CMTS follows the following RLBG assignment rules:

- If there is no fiber node configuration, there is no change in the candidate RLBG list. However, if the fiber node is configured, the fiber node must be configured correctly to reflect the real fiber node connection.
- If the cable modem is inside a fiber node, only those RLBGs that are inside that fiber node are selected.
- If the cable modem is not inside any fiber node, that is, the fiber node configuration does not cover all the channels, only those RLBGs that are not inside any fiber node are selected.
- If an RLBG spans across multiple fiber nodes, it is not considered to be inside any fiber node.
- If no candidate RLBG is found, cable modems are assigned to the GLBG, if the GLBG exists.

## Channel Assignment

For cable modems operating in MRC mode, the registration request message can have multiple TLVs to influence the selection of upstream and downstream channels that the Cisco CMTS assigns. To avoid conflicts between the multiple TLVs, the Cisco CMTS follows the precedence order defined below:

1. TLV 56—Channel Assignment
2. TLV 43.11—Service Type Identifier
3. TLV 43.3—Load Balancing Group ID
4. TLVs 24/25.31-33—Service Flow Attribute Masks
5. TLV 43.9—CM Attribute Masks

The Cisco CMTS must follow this TLV precedence order for cable modems not operating in MRC mode:

1. TLV 43.11—Service Type Identifier
2. TLV 43.3—Load Balancing Group ID
3. TLV 43.9—CM Attribute Masks
4. TLVs 24/25.31-33—Service Flow Attribute Masks



**Note** When a target for the new receive channel configuration (RCC) and Transmit channel configuration (TCC) is selected, ensure that the service level for cable modems is not decreased. Target total RCCs and TCCs must not be less than the source total RCCs and TCCs so that cable modems can keep their service level unchanged. This may cause some unbalanced results when high capacity cable modems come online, later releases..

The Cisco CMTS also considers the DOCSIS 3.0 cable modem capabilities defined in the registration request message and assigns the maximum number of channels that the CM requests.

The tables below define the load balancing matrix for RLBG and GLBG assignment:

**Table 46: RLBG Assignment for DOCSIS Cable Modems**

Operational Mode	MAC Version				
	DOCSIS 3.0 CM	DOCSIS 2.x CM	DOCSIS 2.0 CM	DOCSIS 1.1 CM	DOCSIS 1.0 CM
Non-MRC mode (online)	Assigned	Assigned	Assigned	Assigned	Assigned
MRC mode only (w-online)	Assigned	Assigned	Assigned	NA	NA
MRC/MTC mode (UB-online)	Assigned	NA	NA	NA	NA
	DOCSIS 3.0 cable modems are assigned to the DOCSIS 3.0 RLBG	NA	NA	NA	NA

**Table 47: GLBG Assignment for DOCSIS Cable Modems**

Operational Mode	MAC Version				
	DOCSIS 3.0 CM	DOCSIS 2.x CM	DOCSIS 2.0 CM	DOCSIS 1.1 CM	DOCSIS 1.0 CM
Non-MRC mode (online)	Assigned to the DOCSIS 2.0 GLBG without MD-DS-SG-ID/MD-US-SG-ID				
	Assigned to the DOCSIS 3.0 GLBG with MD-DS-SG-ID/MD-US-SG-ID		NA	NA	NA
MRC mode only (w-online)	Assigned to the DOCSIS 2.0 GLBG without MD-DS-SG-ID/MD-US-SG-ID				
	Assigned to the DOCSIS 3.0 GLBG with MD-DS-SG-ID/MD-US-SG-ID		NA	NA	NA
MRC/MTC mode (UB-online)	Assigned	NA	NA	NA	NA
	DOCSIS 3.0 cable modems are assigned to the DOCSIS 3.0 GLBG	NA	NA	NA	NA

The tables below give a snapshot view of the load balancing methods and the operations used to "move" bonded and non-bonded CMs.

Table 48: Load Balancing Method to Move Bonded and Non-bonded cable modems

Modem Mode	Dynamic Service Charge (Initialization Technique)	
	Within MAC Domain	Across MAC Domains
DOCSIS 3.0 cable modems in MTC mode	NA	DCC initialization technique 0
DOCSIS 3.0/DOCSIS 2.x cable modems in MRC-only mode	DCC initialization technique 0 <b>Note</b> CM with primary DS outside RLBG moves inside RLBG with DOCSIS 2.0 LB.	DCC initialization technique 0
DOCSIS 3.0 cable modems in MRC-only mode	DCC <b>Note</b> CM outside RLBG moves inside RLBG with DOCSIS 2.0 LB.	DCC initialization technique 0
DOCSIS 2.x cable modems in MRC-only mode	DCC/UCC <b>Note</b> CM outside RLBG moves inside RLBG with DOCSIS 2.0 LB.	DCC initialization technique 0
DOCSIS 2.0 /DOCSIS 1.1 cable modems in NB mode	DCC <b>Note</b> CM outside RLBG moves inside RLBG with DOCSIS 2.0 LB.	DCC initialization technique 0
	UCC <b>Note</b> CM outside RLBG moves inside RLBG with DOCSIS 2.0 LB.	UCC
DOCSIS 1.0 in NB mode	Force reinitialize CM <b>Note</b> CM outside RLBG moves inside RLBG with DOCSIS 2.0 LB.	Force reinitialize CM
	UCC <b>Note</b> CM outside RLBG moves inside RLBG with DOCSIS 2.0 LB.	UCC

Table 49: Using DCC/DBC to Load Balance Bonded and Non-bonded Cable Modems

Channel	CM in MRC, non-MTC Mode	DOCSIS 1.1/DOCSIS 2.0 cable modems with Single US/DS	DOCSIS 1.0 cable modems with Single US/DS
Upstream (US)	DCC	DCC	UCC
Downstream (DS)	NA (within the same MAC domain)	DCC (within the same MAC domain).	Force reinitialize CM
	DCC with initialization technique 0 when moving cable modems across MAC domains.	DCC with initialization technique 0 when moving cable modems across MAC domains.	Force reinitialize CM



### Error Handling of Channel Assignment

This restriction is modified. As long as the interface state of the channels is not "administratively down", all channels are available for LBG assignment. For other load balancing operations, such as moving modems using DCC, UCC, or DBC, the interface state of the channels should be in "initial", "up", "suspicious", or "testing" states.

The following conditions apply when an LBG is disabled:

- cable modems that match all load balancing criteria can be assigned to an LBG.
- cable modem moves for load balancing are disabled, but cable modem moves from outside of the LBG to inside of the LBG are allowed.

## Upstream Load Balancing for DOCSIS 3.0 Cable Modems in Single Upstream Mode

The upstream load balancing functionality enables the Cisco CMTS router to effectively handle upstream traffic for wideband and narrowband cable modems that are in single upstream mode. Single upstream mode (Mx1) means that the modems cannot send upstream traffic on multiple upstream channels. In the event of traffic overload on a single upstream channel of a wideband or narrowband cable modem, the Cisco CMTS router automatically moves the cable modem to another upstream channel in the same load balancing group.



---

**Note** A cable modem operating in single upstream mode is assigned to a load balancing group based on the primary channel of the modem. A cable modem in single upstream mode can support multiple receive channel (MRC) mode or narrowband mode. However, a cable modem in single upstream mode cannot support multiple transmit channel mode (MTC).

---

## Auto-generate DOCSIS 2.0 GLBG

Cisco CMTS does not automatically implement DOCSIS 2.0 GLBG. DOCSIS 2.0 GLBG is configured manually after a new fiber node - MAC domain (FN-MD) pair is added.

This enhancement to automatically generate DOCSIS 2.0 GLBG after adding a new FN-MD pair and resolving a new combination of MAC domain, cable modem, and service group (MD-CM-SG). This enhancement is implemented through a new command **cable load-balance d20 GLBG auto-generate**. The command has options to renew and update DOCSIS 2.0 GLBGs for a fiber node configuration.

## Independent Upstream/Downstream Throughput Rules

Currently, during upstream or downstream load balancing, to move modems in load balancing operations, Cisco CMTS applies the DOCSIS policy throughput rules to both upstream and downstream throughput to upstream or downstream load balancing operations. In other words, for downstream load balancing, both upstream and downstream sets of rules are applied and similarly for upstream load balancing both set of rules are applied. This prevents movement of modems with low upstream or high downstream throughput and high upstream or low downstream throughput.

Upstream or downstream throughput rules are checked independently to corresponding upstream or downstream load balancing operations. During upstream load balancing, only upstream throughput rules are checked, and during downstream load balancing, only downstream throughput rules are checked.

The following important points are implemented for independent upstream/downstream throughput rules:

- If DOCSIS 2.0 load balancing policy configured is **us-across-ds**, it is recommended to configure a maximum of 16 downstream channels and 8 upstream channels.
- If a load balancing operation involves a change only in the downstream channel of a cable modem without any change to the upstream channel, then only the downstream lower boundary rules are checked.
- If a load balancing operation involves a change only in the upstream channel of a cable modem without any change to the downstream channel, then only the upstream lower boundary rules are checked.
- If a load balancing operation involves a change in both the upstream and downstream channels of a cable modem, then the modem rule check must pass all the rules for that (upstream or downstream) load balancing.
- If the load balancing policy configured is **pure-ds-load**, then only the downstream rules are checked.
- If the load balancing policy configured is **us-across-ds** or both **us-across-ds** and **pure-ds-load**, then two types of target interfaces occur as follows:
  - Local interface—where the cable modem shares the upstream with the source. Only downstream load balancing operation occurs.
  - Remote interface—where the the cable modem does not share the upstream with the source. The upstream/downstream load balancing is triggered by upstream load.

If the load balancing policy configured is neither **us-across-ds** nor **pure-ds-load**, then the load balancing is done based on Mac domain load.

## How to Configure DOCSIS Load Balancing Groups

The Restricted/General Load Balancing and Narrowband Dynamic Bandwidth Sharing with Downstream Dynamic Load Balancing feature can be configured as follows:

- A user can configure a DOCSIS 2.0 general load balancing group (GLBG) on the Cisco CMTS according to DOCSIS specification. The Cisco CMTS creates a DOCSIS 3.0 GLBG for each Media Access Control Domain Cable Modem Service Group (MD-CM-SG) automatically and checks whether the GLBG contains both upstream and downstream channels.
- A cable modem that is not provisioned to any RLBG and cannot resolve its MD-CM-SG gets assigned to a DOCSIS 2.0 GLBG. However, if the cable modem resolves its MD-CM-SG, it gets assigned to a DOCSIS 3.0 GLBG.
- A user can configure RLBGs and any upstream or downstream channel into multiple RLBGs on the Cisco CMTS. The Cisco CMTS checks whether a RLBG contains both upstream and downstream channels. A RLBG can cross multiple MDs.
- A backward compatibility with existing Cisco LB schemes is maintained. The users can switch between the old and new DOCSIS 3.0 compliant LB schemes.



---

**Note** When the Cisco IOS system is upgraded, if the `docsis-policy` configuration of the DOCSIS load balancing groups, is missing in the output of the **show running-config** command, apply the `docsis-policy` to the DOCSIS load balancing groups using the **docsis-policy *policy-id*** command again.

---

The following sections describe how to create and configure DOCSIS load balancing groups to enable DOCSIS load balancing on the Cisco CMTS:

## Configuring DOCSIS 3.0 and 2.0 RLBG and DOCSIS 2.0 GLBG

This section describes how to create and configure a DOCSIS load balancing group. There is a separate configuration mode for a DOCSIS load balancing group that is different from the legacy load balancing group.



**Note** UGS/PCMM policy and threshold do not apply on DOCSIS 3.0 LB.

### Procedure

	Command or Action	Purpose
Step 1	<b>enable</b> <b>Example:</b> Router> <b>enable</b>	Enables privileged EXEC mode. <ul style="list-style-type: none"> <li>• Enter your password if prompted.</li> </ul>
Step 2	<b>configure terminal</b> <b>Example:</b> Router# <b>configure terminal</b>	Enters global configuration mode.
Step 3	<b>cable load-balance docsis-enable</b> <b>Example:</b> Router(config)# <b>cable load-balance docsis-enable</b>	Enables DOCSIS load balancing on the Cisco CMTS.
Step 4	<b>cable load-balance docsis-group</b> <i>docsis-group-id</i> <b>Example:</b> Router(config)# <b>cable load-balance docsis-group</b> <b>1</b>	Creates a DOCSIS load balance group on the Cisco CMTS, with the following parameter: The router enters DOCSIS load balancing group configuration mode.
Step 5	<b>init-tech-list</b> <i>tech-list</i> [ <b>ucc</b> ] <b>Example:</b> Router(config-lb-group)# <b>init-tech-list</b> <b>1</b> <b>ucc</b>	Sets the DCC initialization techniques that the Cisco CMTS can use to load balance cable modems.
Step 6	<b>downstream</b> { <b>Cable</b> { <i>slot/subslot/port</i>   <i>slot/port</i> }   <b>Integrated-Cable</b> { <i>slot/subslot/bay</i>   <i>slot/port</i> } { <b>rf-channel</b> <i>group list</i> } {  <i>slot/port</i> } { <b>rf-channel</b> <i>group list</i> }}	Sets the downstream RF channels.

	Command or Action	Purpose
	<p><b>Example:</b></p> <pre>Router(config-lb-group)# downstream integrated-Cable 5/0/0 rf-channel 2</pre>	
<b>Step 7</b>	<p><b>upstream Cable</b> <i>{slot/subslot/port   slot/port}</i> <i>upstream-list</i></p> <p><b>Example:</b></p> <pre>Router(config-lb-group)# upstream Cable 1/0 2</pre>	Sets upstream channels with the following parameters:
<b>Step 8</b>	<p><b>docsis-policy</b> <i>policy-id</i></p> <p><b>Example:</b></p> <pre>Router(config-lb-group)# docsis-policy 0</pre>	Assigns a policy to a group with the parameter that becomes the default policy assigned to the CM, if the CM does not choose a different policy.
<b>Step 9</b>	<p><b>restricted</b></p> <p><b>Example:</b></p> <pre>Router(config-lb-group)# restricted</pre>	Selects the restricted group type. By default, the general group type is selected.
<b>Step 10</b>	<p><b>init-tech-ovr Cable</b> <i>{slot/subslot/port   slot/port}</i> <i>upstream Cable</i> <i>{slot/subslot/port   slot/port}</i> <i>upstream init-tech-list 0-4 [ucc]</i></p> <p><b>Example:</b></p> <pre>Router(config-lb-group)# init-tech-ovr Cable 8/1/0 0 Cable 8/1/1 1 init-tech-list 1 ucc</pre>	<p>Sets DCC initialization techniques that overrides the physical upstream channel pair. The <b>init-tech-ovr</b> command can also be used to determine whether the UCC can be used for modems during dynamic upstream load balancing.</p> <p>The following parameters override the physical upstream channel pair:</p> <p><b>Note</b> The <b>init-tech-list</b> keyword accepts an upstream that is not added into the load balancing group. The upstream channel pair is invalid until the upstream is added. When the load balancing group is removed, all upstream channel pairs are also removed.</p>
<b>Step 11</b>	<p><b>service-type-id</b> <i>string</i></p> <p><b>Example:</b></p> <pre>Router(config-lb-group)# service-type-id commercial</pre>	Adds a service type ID, with the following parameter, that is compared against the cable modem provisioned service type ID, to determine an appropriate restricted load balancing group (RLBG):
<b>Step 12</b>	<p><b>tag</b> <i>tag name</i></p> <p><b>Example:</b></p>	Adds a tag to the RLBG.

	Command or Action	Purpose
	<code>Router(config-lb-group)# tag t1</code>	
<b>Step 13</b>	<b>interval</b> <1-1000> <b>Example:</b> <code>Router(config-lb-group)# interval 60</code>	Sets the time interval, the Cisco CMTS waits before checking the load on an interface.
<b>Step 14</b>	<b>method</b> {modems   service-flows   utilization} {us-method {modems   service-flows   utilization}} <b>Example:</b> <code>Router(config-lb-group)# method modems us-method modems</code>	Selects the method the Cisco CMTS use to determine the load.
<b>Step 15</b>	<b>policy</b> {pcmm   ugs   us-across-ds   pure-ds-load} <b>Example:</b> <code>Router(config-lb-group)# policy us-across-ds</code> <code>Router(config-lb-group)# policy ugs</code> <code>Router(config-lb-group)# policy pure-ds-load</code>	Selects the modems based on the type of service flow that are balanced.
<b>Step 16</b>	<b>threshold</b> {load {minimum <1-100>   <1-100>}   pcmm <1-100>   stability <0-100>   ugs <1-100>} <b>Example:</b> <code>Router(config-lb-group)# threshold load minimum 10</code> <code>Router(config-lb-group)# threshold pcmm 70</code> <code>Router(config-lb-group)# threshold load 10</code> <code>Router(config-lb-group)# threshold stability 50</code> <code>Router(config-lb-group)# threshold ugs 70</code>	Selects the percentage of use beyond which load balancing occurs.
<b>Step 17</b>	<b>exit</b> <b>Example:</b> <code>Router# exit</code>	Exits DOCSIS LBG configuration.

## Configuring DOCSIS 3.0 GLBG

The following sections describe how to configure a DOCSIS 3.0 GLBG and also how to configure default values of DOCSIS 3.0 certification for the DOCSIS 3.0 general group:



**Note** If a Cable interface on the line card is in "no shut down" state, the associated DOCSIS 3.0 GLBGs are restored in the running-configuration.

## Configuring a DOCSIS 3.0 General Load Balancing Group

This section describes how to configure a DOCSIS 3.0 general load balancing group.

### Procedure

	Command or Action	Purpose
<b>Step 1</b>	<b>enable</b> <b>Example:</b> Router> <b>enable</b>	Enables privileged EXEC mode. <ul style="list-style-type: none"><li>• Enter your password if prompted.</li></ul>
<b>Step 2</b>	<b>configure terminal</b> <b>Example:</b> Router# <b>configure terminal</b>	Enters global configuration mode.
<b>Step 3</b>	<b>cable load-balance docsis-enable</b> <b>Example:</b> Router(config)# <b>cable load-balance docsis-enable</b>	Enables DOCSIS load balancing on the Cisco CMTS.
<b>Step 4</b>	<b>cable load-balance docsis-group FN <i>fn-id</i> MD <i>cable</i> {<i>slot/subslot/port</i>   <i>slot/port</i>}</b> <b>Example:</b> Router(config)# <b>cable load-balance docsis-group FN 1 MD c5/0/0</b>	Enters the DOCSIS load balancing group configuration mode.
<b>Step 5</b>	<b>init-tech-list <i>tech-list</i> [ucc]</b> <b>Example:</b> Router(config-lb-group)# <b>init-tech-list 1 ucc</b>	Sets the DCC initialization technique list, with the following parameters.
<b>Step 6</b>	<b>disable</b> <b>Example:</b> Router(config-lb-group)# <b>disable</b>	Disables the load balance group.
<b>Step 7</b>	<b>docsis-policy <i>policy-id</i></b> <b>Example:</b> Router(config-lb-group)# <b>docsis-policy 0</b>	Sets the load balance group policy.
<b>Step 8</b>	<b>interval <i>I-1000</i></b> <b>Example:</b> Router(config-lb-group)# <b>interval 10</b>	Sets the interface polling interval.
<b>Step 9</b>	<b>method {modems   service-flows   utilization} {us-method {modems   service-flows   utilization}}</b> <b>Example:</b> Router(config-lb-group)# <b>method modems us-method modems</b>	Sets the load balancing type or method.

	Command or Action	Purpose
Step 10	<b>policy</b> { <b>pcmm</b>   <b>ugs</b>   <b>us-across-ds</b>   <b>pure-ds-load</b> } <b>Example:</b> Router(config-lb-group)# <b>policy us-across-ds</b>	Sets load balancing policy.
Step 11	<b>threshold</b> { <b>load</b> { <b>minimum</b> <i>1-100</i>   <i>1-100</i> }   <b>pcmm</b> <i>1-100</i>   <b>stability</b> <i>0-100</i>   <b>ugs</b> <i>1-100</i> } <b>Example:</b> Router(config-lb-group)# <b>threshold pcmm 70</b>	Sets the load balancing threshold in percentage.
Step 12	<b>exit</b> <b>Example:</b> Router# <b>exit</b>	Exits the DOCSIS load balancing group configuration mode.

## Configuring Default Values of DOCSIS 3.0 Load Balancing Group

This section describes how to configure default values of DOCSIS 3.0 certification for a DOCSIS 3.0 general group on the Cisco CMTS. A DOCSIS 3.0 general group is automatically created for each MD-CM-SG derived from the fiber node (FN) configuration, and the group parameters are set as default values.



**Note** The configured default values of DOCSIS 3.0 certification are applicable to the new automatically created DOCSIS 3.0 GLBGs and do not affect the existing DOCSIS 3.0 GLBGs. When a DOCSIS 3.0 GLBG is removed and recreated, its group parameters do not change.



**Note** The default settings for interface polling interval, load balancing method, policy for modems selection, and threshold usage in percent, can be configured for DOCSIS 3.0 general group. For more information, see the [Cisco CMTS Cable Command Reference](#).

### Procedure

	Command or Action	Purpose
Step 1	<b>enable</b> <b>Example:</b> Router> <b>enable</b>	Enables privileged EXEC mode. <ul style="list-style-type: none"> <li>• Enter your password if prompted.</li> </ul>
Step 2	<b>configure terminal</b> <b>Example:</b> Router# <b>configure terminal</b>	Enters global configuration mode.
Step 3	<b>cable load-balance d30-ggrp-default disable</b> <b>Example:</b>	Disables the default values of the DOCSIS 3.0 general load balance group (GLBG).

	Command or Action	Purpose
	Router(config)# <code>cable load-balance d30-ggrp-default disable</code>	
<b>Step 4</b>	<b>cable load-balance d30-ggrp-default init-tech-list</b> <i>tech-list</i> <b>Example:</b> Router(config)# <code>cable load-balance d30-ggrp-default init-tech-list 1</code>	Sets the default DOCSIS 3.0 GLBGs DCC and dynamic bonding change (DBC) initialization techniques.
<b>Step 5</b>	<b>cable load-balance d30-ggrp-default docsis-policy</b> <i>0-0xffffffff</i> <b>Example:</b> Router(config)# <code>cable load-balance d30-ggrp-default docsis-policy 2</code>	Sets the default DOCSIS 3.0 GLBGs policy ID.
<b>Step 6</b>	<b>exit</b> <b>Example:</b> Router# <code>exit</code>	Exits the global configuration mode.

## Configuring Cable Modems to RLBG or a Service Type ID

This section shows how to configure a list of cable modems that are statically provisioned at the Cisco CMTS to a RLBG or a service type ID.

### Procedure

	Command or Action	Purpose
<b>Step 1</b>	<b>enable</b> <b>Example:</b> Router> <code>enable</code>	Enables privileged EXEC mode. <ul style="list-style-type: none"> <li>• Enter your password if prompted.</li> </ul>
<b>Step 2</b>	<b>configure terminal</b> <b>Example:</b> Router# <code>configure terminal</code>	Enters global configuration mode.
<b>Step 3</b>	<b>cable load-balance restrict modem</b> <i>index mac-addr [mac-mask] {docsis-group docsis-group-id   service-type-id string}</i> <b>Example:</b> Router(config)# <code>cable load-balance restrict modem 1 001a.c30c.7eee FFFF.FFFF.0000 docsis-group 100</code>	Assigns a modem or a group of modems with a common MAC mask to a load balancing group or a service type ID.
<b>Step 4</b>	<b>exit</b> <b>Example:</b> Router# <code>exit</code>	Exits the global configuration mode.



## Configuring Rules and Policies

This section shows how to create and configure rules and DOCSIS policies to restrict the movement of modems during load balancing. Rules determine whether a modem can be moved and during which time periods. The time periods are measured in seconds with the start time being an offset from midnight measured in seconds. Rules are created individually and can be combined into policies. The user is able to create DOCSIS policies that consist of one or more rules. When more than one rule is part of a DOCSIS policy, all rules apply. Each group has a default DOCSIS policy.

### Procedure

	Command or Action	Purpose
Step 1	<b>enable</b> <b>Example:</b> Router> <b>enable</b>	Enables privileged EXEC mode. <ul style="list-style-type: none"> <li>• Enter your password if prompted.</li> </ul>
Step 2	<b>configure terminal</b> <b>Example:</b> Router# <b>configure terminal</b>	Enters global configuration mode.
Step 3	<b>cable load-balance rule rule-id</b> <b>Example:</b> Router(config)# <b>cable load-balance rule 1</b>	Creates a rule to prevent the modem from being moved.
Step 4	<b>cable load-balance rule rule-id {enabled   disabled   {disable-period dis-start 0-86400 dis-period &lt;0-86400&gt;}   disable-throughput-lowerbound ds   us thrupt in kbps   vdoc-enabled}</b> <b>Example:</b> Router(config)# <b>cable load-balance rule 1 disable-period dis-start 40 dis-period 50</b>	Configures the rule. <b>Note</b> Static multicast groups should be configured on the appropriate bundle interface as well as on the correct forwarding interfaces to enable this rule. This feature will not be supported on load balancing groups which are derived from fiber node configuration and with multicast encryption.
Step 5	<b>cable load-balance docsis-policy policy-id rule rule-id</b> <b>Example:</b> Router(config)# <b>cable load-balance docsis-policy 2 rule 1</b>	Associates a particular rule with the DOCSIS policy with the following parameters:
Step 6	<b>exit</b> <b>Example:</b> Router# <b>exit</b>	Exits the global configuration mode.

## Troubleshooting Tips

**Problem** When you disable load balancing and enable it for the next day using the **cable load-balance rule rule-id disable-period dis-start start-time dis-period disable-period** command, the load balancing is enabled at 12.00 am instead of the configured *disable-period*.

**Possible Cause** Load balancing rule cannot be disabled and enabled on the next day (that is, after 24 hours) using a single load balancing rule.

**Solution** Configure separate load balancing rules for disabling load balancing and enabling it on the next day. Configure the rule to disable load balancing using the **cable load-balance rule rule-id disable-period dis-start start-time dis-period 0** command. Configure the rule to enable load balancing using the **cable load-balance rule rule-id disable-period dis-start 0 dis-period disable-period** command to enable it for the next day.

## Configuring Load Balancing Parameter for a Cable Modem Movement Failure

This section describes how to configure the number of times a CM can fail before the CM is removed from the dynamic load balancing group.

### Procedure

	Command or Action	Purpose
Step 1	<b>enable</b> <b>Example:</b> Router> <b>enable</b>	Enables privileged EXEC mode. <ul style="list-style-type: none"><li>• Enter your password if prompted.</li></ul>
Step 2	<b>configure terminal</b> <b>Example:</b> Router# <b>configure terminal</b>	Enters global configuration mode.
Step 3	<b>cable load-balance modem max-failures 0-100</b> <b>Example:</b> Router(config)# <b>cable load-balance modem max-failures 10</b>	Configures the number of times a CM can fail before the CM is removed from the dynamic load balancing group.
Step 4	<b>exit</b> <b>Example:</b> Router# <b>exit</b>	Exits the global configuration mode.

## Creating and Configuring TLV type Tag

The tags for TLV type matching rule are created and configured in this section.

### Procedure

	Command or Action	Purpose
Step 1	<b>enable</b> <b>Example:</b> Router> <b>enable</b>	Enables privileged EXEC mode. <ul style="list-style-type: none"><li>• Enter your password if prompted.</li></ul>
Step 2	<b>configure terminal</b> <b>Example:</b>	Enters global configuration mode.

	Command or Action	Purpose
	Router# <b>configure terminal</b>	
<b>Step 3</b>	<b>cable tag</b> <i>I-1000</i> <b>Example:</b> Router(config)# <b>cable tag 1</b>	Creates a tag. Enters the cmts-tag configuration mode.
<b>Step 4</b>	<b>name</b> <i>tag name</i> <b>Example:</b> Router(cmts-tag)# <b>name CSCO</b>	Specifies the name of the tag.
<b>Step 5</b>	<b>[exclude] service-type-id</b> <i>service-type-id</i> <b>Example:</b> Router(cmts-tag)# <b>service-type-id HSD</b>	Configures the specified service type ID for the tag.
<b>Step 6</b>	<b>[exclude]service-class</b> <i>service-class-name</i> <b>Example:</b> Router(cmts-tag)# <b>service-class work</b>	Configures the specified service class name for the tag.
<b>Step 7</b>	<b>[exclude] docsis-version</b> <i>docsis version</i> <b>Example:</b> Router(cmts-tag)# <b>docsis-version docsis20</b>	Configures the specified DOCSIS version of the cable modem for the tag.
<b>Step 8</b>	<b>[exclude] oui</b> <i>oui of CM</i> <b>Example:</b> Router(cmts-tag)# <b>oui 00.1a.c3</b>	Configures the specified OUI of the cable modem for the tag.
<b>Step 9</b>	<b>[exclude] tlv</b> <i>type value</i> <b>Example:</b> Router(cmts-tag)# <b>tlv mrcc 4</b>	Configures the specified TLV type for the tag.
<b>Step 10</b>	<b>override</b> <b>Example:</b> Router(cmts-tag)# <b>override</b>	Overrides the TLV or SNMP during load balancing an RLBG.
<b>Step 11</b>	<b>exit</b> <b>Example:</b> Router(cmts-tag)# <b>exit</b>	Exits the cmts-tag configuration mode.
<b>Step 12</b>	<b>cable load-balance docsis-group</b> <i>docsis-group-id</i> <b>Example:</b> Router(config)# <b>cable load-balance docsis-group 1</b>	Creates a DOCSIS load balancing group on the Cisco CMTS. If the DOCSIS load balancing group is already present, the router enters the specified DOCSIS load balancing group configuration mode.

	Command or Action	Purpose
Step 13	<b>tag</b> <i>tag name</i> <b>Example:</b> Router(config-lb-group)# <b>tag</b> CSCO	Adds a tag to the load balancing group.
Step 14	<b>exit</b> <b>Example:</b> Router(config-lb-group)# <b>exit</b>	Exits the DOCSIS load balancing group configuration mode.
Step 15	<b>cable load-balance docsis-policy</b> <i>policy-id tag tag name</i> <b>[override]</b> <b>Example:</b> Router(config)# <b>cable load-balance docsis-policy</b> <b>2 tag</b> CSCO	Creates a DOCSIS policy and associates a new rule or an existing rule with the policy.
Step 16	<b>exit</b> <b>Example:</b> Router# <b>exit</b>	Exits the global configuration mode.

## Configuration Examples for DOCSIS Load Balancing Groups

This section describes a sample configuration example for configuring DOCSIS Load Balancing Groups including Restricted/General Load Balancing and downstream dynamic load balancing:

### Example: Configuring a Tag

The following example shows how you can configure the tag to exclude a DOCSIS version, a MAC address, a service class name or a service type ID:

```
Router# configure terminal
Enter configuration commands, one per line. End with CNTL/Z.
Router(config)# cable tag 1
Router(cmts-tag)# exclude ?
  docsis-version  set the match rule for docsis version
  oui             set the match rule for oui
  service-class   set the match rule for service class name
  service-type-id set the match rule for service type id
Router(cmts-tag)# exclude docsis-version ?
  docsis10 Match docsis 1.0 modems
  docsis11 Match docsis 1.1 modems
  docsis20 Match docsis 2.0 modems
  docsis30 Match docsis 3.0 modems
Router(cmts-tag)# exclude docsis-version docsis10
Router(cmts-tag)# exclude oui ?
  WORD OUI of the vendor in the format xx.xx.xx or xx:xx:xx
Router(cmts-tag)# exclude oui 00.1a.c3
Router(cmts-tag)# exclude service-class ?
  WORD Service class name
Router(cmts-tag)# exclude service-class work
Router(cmts-tag)# exclude service-type-id ?
```

```
WORD Service Type ID
Router(cmts-tag) # exclude service-type-id commercial
```

## Example: Disabling Load Balancing

Use the following commands to disable DOCSIS 3.0 GLBG:

```
Router(config)# cable load-balance docsis-group FN 1 MD cable 6/0/0
Router(config-lb-group) # disable
Router(config-lb-group) #
```

Use the following commands to disable DOCSIS 3.0 RLBG:

```
Router(config)# cable load-balance docsis-group 1
Router(config-lb-group) # disable
Router(config-lb-group) #
```

# How to Configure Load Balancing with Operational Simplification

To configure Load Balancing Groups with Operational Simplification, complete the following steps:

### SUMMARY STEPS

1. Define the global common Load Balancing profile. Specify the Load Balancing Group configure: method, interval, threshold, policy, and so on.
2. Define the Load Balancing Group under service-group profile. Associate the Load Balancing profile with Load Balancing group. Configure the DS and US channels.
3. Define the physical mapping info for US or DS channels under fiber-mode.
4. Define the service-group profile under Fiber-node.

### DETAILED STEPS

	Command or Action	Purpose
Step 1	<p>Define the global common Load Balancing profile. Specify the Load Balancing Group configure: method, interval, threshold, policy, and so on.</p> <p><b>Example:</b></p> <pre>cable profile load-balance lb_1 disable method utilization primary-distributed us-method utilization threshold load 2 policy pcmm interval 1</pre>	

	Command or Action	Purpose
<b>Step 2</b>	<p>Define the Load Balancing Group under service-group profile. Associate the Load Balancing profile with Load Balancing group. Configure the DS and US channels.</p> <p><b>Example:</b></p> <pre>cable profile service-group sg load-balance docsis-group 0 profile lb_1   downstream sg-channel 0-7   upstream 0 sg-channel 0   upstream 1 sg-channel 1</pre>	
<b>Step 3</b>	<p>Define the physical mapping info for US or DS channels under fiber-mode.</p> <p><b>Example:</b></p> <pre>cable fiber-node 1 downstream sg-channel 0 15 downstream-Cable 6/0/0 rf-channel 0 15 upstream sg-channel 0 3 Upstream-Cable 6/0/0 us-channel 0 3</pre>	
<b>Step 4</b>	<p>Define the service-group profile under Fiber-node.</p> <p><b>Example:</b></p> <pre>cable fiber-node 1 service-group profile sg</pre>	

The Load Balancing Groups are auto-generated when the SG profile is applied.

### Example

An example of the Load Balancing Groups Operational Simplification configuration, **show run** as is as follows:

```
cable profile load-balance lb
method utilization primary-distributed us-method utilization
threshold load 22
threshold load lcmm 33
policy lcmm
policy pure-ds-load
init-tech-list 1-3

cable profile service-group sg
  load-balance docs is-group 0 profile lb
  downstream sg-channel 0 15
  upstream 0 sg-channel 0
  upstream 1 sg-channel 1
  upstream 2 sg-channel 2
  upstream 3 sg-channel 3
load-balance docsis-group 2 profile RLBG_STB
  downstream sg-channel 0-3 8-11
  upstream 0 sg-channel 0
```

```

cable fiber-node 1
  downstream Downstream-Cable 6/0/0
  upstream Upstream-Cable 6/0/0
  downstream sg-channel 0 15 downstream-Cable downstream-Cable 6/0/0 rf-channel 0 15
    upstream sg-channel 0 3 Upstream-Cable 6/0/0 us-channel 0 3
  service-group profile sg

```

An example of the Load Balancing Groups Operational Simplification configuration, **show derived** as is as follows:

```

cable profile load-balance lb
  method utilization primary-distributed us-method utilization
  threshold load 22
  threshold load lcmm 33
  policy lcmm
  policy pure-ds-load
  init-tech-list 1-3

Cable profile service-group sg
  Load-balance docsis-group 0 profile lb
  downstream sg-channel 0 15
    upstream 0 sg-channel 0
    upstream 1 sg-channel 1
    upstream 2 sg-channel 2
    upstream 3 sg-channel 3
  load-balance docsis-group 2 profile RLBG_STB
    downstream sg-channel 0-3 8-11
    upstream 0 sg-channel 0

Cable fiber-node 1
  downstream Downstream-Cable 6/0/0
  upstream Upstream-Cable 6/0/0
  downstream sg-channel 0 15 downstream-Cable 6/0/0 rf-channel 0 15
  upstream sg-channel 0 3 Upstream-Cable 6/0/0 us-channel 0 3
  service-group profile sg

Cable load-balance docsis-group 2
  restricted
  downstream Downstream-Cable 6/0/0/ rf-channel 0 15
  upstream Upstream-Cable 6/0/0 us-channel 0-3
  method utilization primary-distributed
  threshold load 22
  threshold pcmm 33
  policy lcmm
  policy pure-ds-load
  init-tech-list 1-3
  cable managed fiber-node 1
  cable load-balance-profile lb
  cable load-balance docsis-group 3
  restricted
  downstream Downstream-Cable 6/0/0 rf-channel 0-3 8-11
  Upstream Upstream-Cable 6/0/0 us-channel 0
  Threshold load 55
  Interval 5
  Cable managed fiber-node 1
  Cable load-balance-profile RLBG_STB

```

## Load Balancing Groups with Operational Simplification

The Cisco IOS XE Gibraltar 16.10.1d supports simplified Load Balancing configuration in the Operational Simplification service group profile. Currently, CMTS supports auto creation of D30 GLBGs based on the existing configuration. Load Balancing would now support creation of RLBGs and D20 GLBGs.

Following are the salient features of the feature:

- For D20 GLBG created by Operational Simplification, the Group ID is in range [65024, 65535]. This follows legacy design.
- For RLBG created by Operational Simplification, the Group ID is related to the information of fiber-node id/us channel controller/docsis-group index in service group file. This also follows legacy range [1, 2147483647]. For example: RLBG ID: 12330208. Where '123' is the Fiber node ID, '302' is the Upstream-Cable 6/0/0, and '08' is the docsis-group index in service group profile.

```
cable profile service-group sg
  load-balance docsis-group 8 profile lb_1
  downstream sg-channel 0-7
  upstream 0 sg-channel 0
  upstream 1 sg-channel 1
```

- The default value of Load Balance profile are equal to the value of “cable load-balance d20-ggrp-default xxx”.
- For Load Balancing Groups that are created by Operational Simplification, the user cannot configure them with CLI.
- For one service group profile, a user is only allowed to configure one GLBG load balance.
- A user can configure a maximum of 20 tags into one load balance profile.
- A user can configure a maximum of 15 service-type-ids into one load balance profile.
- Load Balancing Groups by Operational Simplification supports fly modification.
- For Load Balancing Groups created by Operational Simplification, if a user changes the option of Load Balance profile, the OPS would update all the related LBGs automatically. However, the user cannot change the type of LBGs.

For the Load Balancing Groups created by Operational Simplification, the configuration of the groups would not be displayed for the **show run** or the **show run all** commands. The Load Balancing Groups would only be displayed using the **derived** command. This change can simplify the running configuration.

```
clab-cbr-S11K01#show derived-config | sec cable load
cable load-balance docsis-group 1
restricted
downstream Downstream-Cable 6/0/0 rf-channel 0-7
upstream Upstream-Cable 6/0/0 us-channel 0-1
method utilization primary-distributed
threshold load 2
cable managed fiber-node 1
cable load-balance-profile lb_1
```



# Verifying DOCSIS Load Balancing Groups

This section describes how to use certain show commands to verify the configuration of the Restricted/General Load Balancing and Narrowband Dynamic Bandwidth Sharing with Downstream Dynamic Load Balancing feature.

## Procedure

	Command or Action	Purpose
Step 1	<b>enable</b> <b>Example:</b> Router> <b>enable</b>	Enables privileged EXEC mode. <ul style="list-style-type: none"> <li>• Enter your password if prompted.</li> </ul>
Step 2	<b>show cable load-balance docsis-group</b> <i>{docsis-group-id   FN fn-id MD cable {slot/subslot/port   slot/port}}</i> [ <b>all   load   pending   statistics   target   modem-list   primary-load</b> ] <b>Example:</b> Router# <b>show cable load-balance docsis-group 1</b> Router# <b>show cable load-balance docsis-group fn 1 MD c8/1/4</b>	Displays real-time configurational, statistical, and operational information of the load balancing operations on the router.
Step 3	<b>show cable fiber-node</b> <i>fiber-node-id</i> [ <b>spectrum</b> ] <b>Example:</b> Router# <b>show cable fiber-node 3</b>	Displays information about a fiber node.
Step 4	<b>show cable load-balance</b> [ <b>group n</b> ]   [ <b>all   load   pending   statistics   target   fiber-node-validation</b> ] <b>Example:</b> Router# <b>show cable load-balance group 1</b>	Displays real-time statistical and operational information for load balancing operations. If given without any options, this command displays information for the load balancing groups and each cable interface's current load and load balancing status.
Step 5	<b>show cable modem</b> [ <i>ip-address   mac-address   cable slot/port [upstream port ]   name fqdn</i> ] [ <b>verbose</b> ] <b>Example:</b> Router# <b>show cable modem 40.3.160.15 verbose</b>	Displays information for the registered and unregistered CMs.

## Examples

Use the **show cable load-balance docsis-group** command to see the DOCSIS group status and to see the list of modems in the group, use the **show cable fiber-node** command to see the information on fiber nodes, use the **show cable load-balance** command to see information on LBG and DOCSIS channels, and use the **show cable modem** command to see the information on all the CMs.

The following examples show the output of the **show cable load-balance docsis-group** command:

```
Router# show cable load-balance docsis-group 2
```

```

DOCSIS LB Enabled: Yes
DOCSIS      Group Status Interval DCC mask  Policy      Method Threshold
Group      Index
2          82 RE 10      0xF8(0)/N 0      s/s      1/1/70/70/50
Router# show cable load-balance docsis-group 1 modem-list
US
Mo1/0/0:0/U0      Group Index Mac Address      Priority
Mo1/0/0:0/U0      81      (1)
0000.ca45.9898    0
Mo1/0/0:0/U1      81      (0)
Mo1/0/0:0/U2      81      (2)
0013.711c.0820    0
0016.924f.8300    0

```

The output of the **show cable load-balance docsis-group** command is modified to include an additional field MUPFXLR to display more status information on the modems in the DOCSIS groups. For more information, see the [Cisco IOS CMTS Cable Command Reference](#).

The following example shows the modified output of the **show cable load-balance docsis-group** command:

```

Router#show cable load docsis-group fn 1 md c6/0/0 modem-list
Load for five secs: 1%/0%; one minute: 2%; five minutes: 1%
Time source is NTP, 13:39:31.300 PDT Thu Mar 28 2013
Codes: M - Multicast, U - UGS, P - PCMM, F - Max-Failures, X - eXcluded
L - L2vpn, R - RSVP
Primary DS      Grp Idx MAC Address      RCC-ID Bad Rfid Priority MUPFXLR
In6/0/0:0/UB    40448      (6)
e448.c70c.98af 1      2      -----
e448.c70c.9b76 1      2      -----
e448.c70c.9c15 1      2      -----
e448.c70c.9a92 1      2      -----
e448.c70c.99e4 1      2      -----
e448.c70c.9a35 1      2      -----
In6/0/0:0/U0    40448      (0)
In6/0/0:0/U1    40448      (1)
e448.c70c.9915      2      -----
In6/0/0:0/U2    40448      (0)
In6/0/0:0/U3    40448      (0)
In6/0/0:1/UB    40448      (5)
e448.c70c.9abc 1      2      -----
e448.c70c.993f 1      2      -----
e448.c70c.9927 1      2      -----
e448.c70c.9b82 1      2      -----
4458.2945.2cb8 1      2      -----
In6/0/0:1/U0    40448      (0)
In6/0/0:1/U1    40448      (0)
In6/0/0:1/U2    40448      (0)
In6/0/0:1/U3    40448      (0)
In6/0/0:2/UB    40448      (5)
e448.c70c.9759 1      2      -----
e448.c70c.9a0e 1      2      -----
e448.c70c.992d 1      2      -----
e448.c70c.9a38 1      2      -----
0025.2ed9.9984 1      2      -----L-
In6/0/0:2/U0    40448      (0)
In6/0/0:2/U1    40448      (0)
In6/0/0:2/U2    40448      (0)
In6/0/0:2/U3    40448      (0)
In6/0/0:3/UB    40448      (5)
e448.c70c.9c00 1      2      -----

```

```

                                e448.c70c.99a5 1          2          -----
                                e448.c70c.9a5f 1          2          -----
                                e448.c70c.9a3b 1          2          -----
                                e448.c70c.96b1 1          2          -----
In6/0/0:3/U0  40448  (0)
In6/0/0:3/U1  40448  (0)
In6/0/0:3/U2  40448  (0)
In6/0/0:3/U3  40448  (0)

```

The following example shows the output of the **show cable fiber-node** command:

```

Router# show cable fiber-node
Fiber-Node          Config Status
Fiber-Node 1
  Modular-Cable 1/0/0: 0-1
  FN Config Status: Configured (status flags = 0x01)
  MDD Status: Valid

```

The following examples show the output of the **show cable load-balance** command:

```

Router#show cable load-balance
Group  Interval  Method          DCC Init  Threshold
              Technique  Minimum  Static  Enforce  Ugs  PCMM
1       10       service-flows  1         1         2%     2%     ---     ---
2       10       modems        0         5         10%    ---     ---     ---

```

DOCSIS LB Enabled: No

```

Router# show cable load-balance load
Interface          State  Group  Utilization  Reserved Modems  Flows  Weight
                  |      |      |            |           |         |
Cable5/0/3 (459 MHz) up     1      0%(0%/0%)    0%         7         7       37
Cable5/0/3/U0      up     1      0%           0%         2         2       1.2
Cable5/0/3/U1      up     1      0%           0%         2         2       1.2
Cable5/0/3/U2      up     1      0%           0%         2         2       1.2
Cable5/0/3/U3      up     1      0%           0%         1         1       1.2
Cable5/0/4 (465 MHz) up     1      0%(0%/0%)    0%         7         7       37
Cable5/0/4/U0      up     1      0%           0%         1         1       1.2
Cable5/0/4/U1      up     1      0%           0%         2         2       1.2
Cable5/0/4/U2      up     1      0%           0%         2         2       1.2
Cable5/0/4/U3      up     1      0%           0%         2         2       1.2
Mo1/0/0:0 (555 MHz) down  1      0%(0%/0%)    0%         0         0        0

```

```

Router# show cable load-balance fiber-node-validation

```

```

DOCSIS LBG ID  Match  Channel  Fiber-node list
1              match  Ca5/0/0/U0 {1}
               Ca5/0/0/U1 {1}
               Ca5/0/0/U2 {1}
               Ca5/0/0/U3 {1}
               Mo1/0/0:0 {1}
               Mo1/0/0:1 {1}
2              mismatch Ca5/0/0/U0 {1}
               Ca5/0/0/U1 {1}
               Ca5/0/0/U2 {1}
               Ca5/0/0/U3 {1}
               Ca5/0/0 {}

```

The following example shows the output of the **show cable modem** command:

```

Router# show cable modem 40.3.160.19 verbose
LB group ID assigned(index)      : 1(81)
LB group ID in config file(index) : N/A(N/A)
LB policy ID      : 0
LB policy ID in config file      : 0
LB priority      : 0
Tag                :

```

DOCSIS 3.0 GLBG is generated dynamically by the fiber node configuration, if a valid fiber node is configured.

For example, if the fiber node configuration is:

```

cable fiber-node 2
  downstream Modular-Cable 1/0/0 rf-channel 0-3
  downstream Cable7/0/0
  upstream Cable 7/0 connector 0-3
!

```

The GLBG generated by this fiber node is similar to:

```

Router# show cable load-balance docsis-group fn 2 md cable 7/0/0
DOCSIS 3.0 General LB
MD      FN  Group S Intv DCC mask  Policy      Mtd MD-CM-SG Threshold
      Index      /UCC      D/U      M/E/U/P/S
Ca7/0/0 2   48129 E 30   0xF8(0)/N 0      m/m 0x3C0101 5/10/70/70/50

```

```

Router# show cable load-balance docsis-group fn 2 md cable 7/0/0 all
DOCSIS 3.0 General LB
MD      FN  Group S Intv DCC mask  Policy      Mtd MD-CM-SG Threshold
      Index      /UCC      D/U      M/E/U/P/S
Ca7/0/0 2   48129 E 30   0xF8(0)/N 0      m/m 0x3C0101 5/10/70/70/50
Current load:
DOCSIS load-balancing load
Interface      State  Group  Utilization  Rsvd  NBCM  WB/UB  Flows  Weight
              Index      Total  Total
Cable7/0/0 (333 MHz) up    48129  0%(0%/0%)   0%    2     8     7     37
Cable7/0/0/U0      up    48129  0%           0%   22    7    29    7.6
Cable7/0/0/U1      up    48129  0%           0%   21    8    28    7.6
Cable7/0/0/U2      up    48129  0%           0%   21    8    28    7.6
Cable7/0/0/U3      up    48129  0%           0%   20   10    30    7.6
Mo1/0/0:0 (501 MHz) up    48129  0%(0%/0%)   0%    2    63    2    36
Mo1/0/0:0/U0      up    48129  0%           0%   22    7    29    7.6
Mo1/0/0:0/U1      up    48129  0%           0%   21    8    28    7.6
Mo1/0/0:0/U2      up    48129  0%           0%   21    8    28    7.6
Mo1/0/0:0/U3      up    48129  0%           0%   20   10    30    7.6
Mo1/0/0:1 (507 MHz) up    48129  0%(0%/0%)   0%    1    58    1    36
Mo1/0/0:1/U0      up    48129  0%           0%   22    7    29    7.6
Mo1/0/0:1/U1      up    48129  0%           0%   21    8    28    7.6
Mo1/0/0:1/U2      up    48129  0%           0%   21    8    28    7.6
Mo1/0/0:1/U3      up    48129  0%           0%   20   10    30    7.6
Mo1/0/0:2 (513 MHz) up    48129  0%(0%/0%)   0%    2    59    2    36
Mo1/0/0:2/U0      up    48129  0%           0%   22    7    29    7.6
Mo1/0/0:2/U1      up    48129  0%           0%   21    8    28    7.6
Mo1/0/0:2/U2      up    48129  0%           0%   21    8    28    7.6

```

Mo1/0/0:2/U3	up	48129	0%	0%	20	10	30	7.6
Mo1/0/0:3 (519 MHz)	up	48129	0% (0%/0%)	0%	1	61	1	36
Mo1/0/0:3/U0	up	48129	0%	0%	22	7	29	7.6
Mo1/0/0:3/U1	up	48129	0%	0%	21	8	28	7.6
Mo1/0/0:3/U2	up	48129	0%	0%	21	8	28	7.6
Mo1/0/0:3/U3	up	48129	0%	0%	20	10	30	7.6

Target assignments:

Interface	State	Group	Target
Cable7/0/0 (333 MHz)	up	48129	
Cable7/0/0/U0	up	48129	
Cable7/0/0/U1	up	48129	
Cable7/0/0/U2	up	48129	
Cable7/0/0/U3	up	48129	
Mo1/0/0:0 (501 MHz)	up	48129	Mo1/0/0:1 (507 MHz)
Mo1/0/0:0/U0	up	48129	
Mo1/0/0:0/U1	up	48129	
Mo1/0/0:0/U2	up	48129	
Mo1/0/0:0/U3	up	48129	
Mo1/0/0:1 (507 MHz)	up	48129	
Mo1/0/0:1/U0	up	48129	
Mo1/0/0:1/U1	up	48129	
Mo1/0/0:1/U2	up	48129	
Mo1/0/0:1/U3	up	48129	
Mo1/0/0:2 (513 MHz)	up	48129	
Mo1/0/0:2/U0	up	48129	
Mo1/0/0:2/U1	up	48129	
Mo1/0/0:2/U2	up	48129	
Mo1/0/0:2/U3	up	48129	
Mo1/0/0:3 (519 MHz)	up	48129	
Mo1/0/0:3/U0	up	48129	
Mo1/0/0:3/U1	up	48129	
Mo1/0/0:3/U2	up	48129	
Mo1/0/0:3/U3	up	48129	

Statistics:

Target interface	State	Transfers			
		Complete	Pending	Retries	Failures
Cable7/0/0 (333 MHz)	up	8	0	0	0
Cable7/0/0/U0	up	30	0	0	0
Cable7/0/0/U1	up	83	0	0	0
Cable7/0/0/U2	up	48	0	0	0
Cable7/0/0/U3	up	34	0	0	0
Mo1/0/0:0 (501 MHz)	up	19	0	0	0
Mo1/0/0:0/U0	up	33	0	0	0
Mo1/0/0:0/U1	up	46	0	0	0
Mo1/0/0:0/U2	up	22	0	0	0
Mo1/0/0:0/U3	up	22	0	0	0
Mo1/0/0:1 (507 MHz)	up	22	0	0	0
Mo1/0/0:1/U0	up	9	0	0	0
Mo1/0/0:1/U1	up	19	0	0	0
Mo1/0/0:1/U2	up	15	0	0	0
Mo1/0/0:1/U3	up	21	0	0	0
Mo1/0/0:2 (513 MHz)	up	21	0	0	0
Mo1/0/0:2/U0	up	4	0	0	0
Mo1/0/0:2/U1	up	3	0	0	0
Mo1/0/0:2/U2	up	6	0	0	0
Mo1/0/0:2/U3	up	7	0	0	0
Mo1/0/0:3 (519 MHz)	up	9	0	0	0
Mo1/0/0:3/U0	up	1	0	0	0
Mo1/0/0:3/U1	up	2	0	0	0
Mo1/0/0:3/U2	up	4	0	0	0
Mo1/0/0:3/U3	up	4	0	0	0

Pending:

Modem	Grp	Idx	Primary	RF/RCC	MD/TCS	Action	Active	Retries
-------	-----	-----	---------	--------	--------	--------	--------	---------

Src Target Src Target Time

## Additional References

### Technical Assistance

Description	Link
<p>The Cisco Support website provides extensive online resources, including documentation and tools for troubleshooting and resolving technical issues with Cisco products and technologies.</p> <p>To receive security and technical information about your products, you can subscribe to various services, such as the Product Alert Tool (accessed from Field Notices), the Cisco Technical Services Newsletter, and Really Simple Syndication (RSS) Feeds.</p> <p>Access to most tools on the Cisco Support website requires a Cisco.com user ID and password.</p>	<p><a href="http://www.cisco.com/support">http://www.cisco.com/support</a></p>

## Feature Information for DOCSIS Load Balancing Groups

Use Cisco Feature Navigator to find information about the platform support and software image support. Cisco Feature Navigator enables you to determine which software images support a specific software release, feature set, or platform. To access Cisco Feature Navigator, go to the <https://cfngn.cisco.com/> link. An account on the Cisco.com page is not required.



**Note** The following table lists the software release in which a given feature is introduced. Unless noted otherwise, subsequent releases of that software release train also support that feature.

*Table 50: Feature Information for DOCSIS Load Balancing Groups*

Feature Name	Releases	Feature Information
DOCSIS Load Balancing Groups	Cisco IOS XE Fuji 16.7.1	This feature was integrated on the cisco cBR Series Converged Broadband Routers.
Load Balancing with Operational Simplification	Cisco IOS XE Gibraltar 16.10.1d.	This feature was integrated on the cisco cBR Series Converged Broadband Routers.



## CHAPTER 18

# DOCSIS Load Balancing Movements

Cisco CMTS supports static load balancing for MTC/MRC modems and dynamic load balancing for non-MTC and/or non-MRC modems. Support for configuration of load balancing groups (LBGs) that entail multiple interfaces, multiple load balancing policies, and the option to configure multiple additional load balancing parameters are also included.

The load balancing policies can be configured on the Cisco CMTS, indexed by an ID, to limit the movement of cable modems within a Load Balancing Group (LBG). The cable modem will forward TLV43.1 in its registration request (REG-REQ) message, which is then parsed and stored in the Cisco CMTS. A policy defines whether and when cable modems can be moved within their load balancing groups.

During dynamic load balancing, the specified policy of the cable modem is checked to determine whether the cable modem is allowed to move.

Load balancing supports Dynamic Channel Change (DCC). DCC in DOCSIS 1.1, dynamically changes cable modem upstream or downstream channels without forcing a cable modem to go offline, and without re-registration after the change.

Load balancing distributes downstream load balancing with upstream channel loads in the same upstream load balancing group. This improves upon the prior load balancing limitation, in which load balancing was implemented on the basis of the entire downstream channel load.

Load balancing uses rules and policies to decide on moving the cable modems within their LB groups. These policies are created on the Cisco CMTS and chosen on a per-CM basis using type-length-value (TLV) portion (43.1, Policy ID) of REG-REQ. These policies prohibit a modem from being moved or restricted.

A policy contains a set of rules. When the policy is defined by multiple rules, all rules apply in combinations. A rule can be defined as "enabled", "disabled", or "disabled during time period." Each rule can be used by more than one policy.

DOCSIS 3.0 static modem count-based load balancing uses the dynamic bonding change (DBC) to modify the following parameters of DOCSIS 3.0 cable modem with multiple transmit channel (MTC) mode or multiple receive channel(MRC) mode without primary channel change:

- Transmit channel set (TCS)
- Receive channel set (RCS)
- Downstream IDs (DSID) or DSID-associated attributes
- Security association for encrypting downstream traffic

These parameters and additional load balancing schemes are supported on the Cisco CMTS, and described in this document. This document describes all implementations of load balancing on the Cisco CMTS, dependent upon the Cisco IOS release installed and the desired parameters.

Your software release may not support all the features that are documented in this module. For the latest feature information and caveats, see the release notes for your platform and software release. The Feature Information Table at the end of this document provides information about the documented features and lists the releases in which each feature is supported.

Use Cisco Feature Navigator to find information about platform support and Cisco software image support. To access Cisco Feature Navigator, go to <http://tools.cisco.com/ITDIT/CFN/>. An account on <http://www.cisco.com/> is not required.

- [Hardware Compatibility Matrix for the Cisco cBR Series Routers, on page 284](#)
- [Prerequisites, on page 286](#)
- [Restrictions, on page 286](#)
- [Information on the Load Balancing on the Cisco CMTS, on page 291](#)
- [How to Configure Load Balancing, on page 306](#)
- [How to Configure Dynamic Channel Change for Load Balancing, on page 309](#)
- [Configuration Examples for Load Balancing, on page 315](#)
- [Additional References, on page 319](#)
- [Feature Information for DOCSIS Load Balancing Movements, on page 319](#)

## Hardware Compatibility Matrix for the Cisco cBR Series Routers



---

**Note** The hardware components that are introduced in a given Cisco IOS-XE Release are supported in all subsequent releases unless otherwise specified.

---



Table 51: Hardware Compatibility Matrix for the Cisco cBR Series Routers

Cisco CMTS Platform	Processor Engine	Interface Cards
Cisco cBR-8 Converged Broadband Router	<p><b>Cisco IOS-XE Release 16.5.1 and Later Releases</b></p> <p>Cisco cBR-8 Supervisor:</p> <ul style="list-style-type: none"> <li>• PID—CBR-SUP-250G</li> <li>• PID—CBR-CCAP-SUP-160G</li> </ul>	<p><b>Cisco IOS-XE Release 16.5.1 and Later Releases</b></p> <p>Cisco cBR-8 CCAP Line Cards:</p> <ul style="list-style-type: none"> <li>• PID—CBR-LC-8D30-16U30</li> <li>• PID—CBR-LC-8D31-16U30</li> <li>• PID—CBR-RF-PIC</li> <li>• PID—CBR-RF-PROT-PIC</li> <li>• PID—CBR-CCAP-LC-40G</li> <li>• PID—CBR-CCAP-LC-40G-R</li> <li>• PID—CBR-CCAP-LC-G2-R</li> <li>• PID—CBR-SUP-8X10G-PIC</li> <li>• PID—CBR-2X100G-PIC</li> </ul> <p>Digital PICs:</p> <ul style="list-style-type: none"> <li>• PID—CBR-DPIC-8X10G</li> <li>• PID—CBR-DPIC-2X100G</li> </ul> <p>Cisco cBR-8 Downstream PHY Module:</p> <ul style="list-style-type: none"> <li>• PID—CBR-D31-DS-MOD</li> </ul> <p>Cisco cBR-8 Upstream PHY Modules:</p> <ul style="list-style-type: none"> <li>• PID—CBR-D31-US-MOD</li> </ul>



**Note** Do not use DPICs (8X10G and 2x100G) to forward IP traffic, as it may cause buffer exhaustion, leading to line card reload.

The only allowed traffic on a DPIC interface is DEPI, UEPI, and GCP traffic from the Cisco cBR-8 router to Remote PHY devices. Other traffic such as DHCP, SSH, and UTSC should flow via another router, since DPICs cannot be used for normal routing.

# Prerequisites

## Prerequisites for Load Balancing

The Load Balancing feature has the following prerequisites:

- Load balancing can be done only on upstreams and downstreams that share physical connectivity with the same group of cable modems.

## Prerequisites for Dynamic Channel Change for Load Balancing

- DCC can be done only to a cable modem that is physically connected to both source and target upstream or downstream channels, or both.
- Upstreams and downstream channels that share the same physical connectivity must have different center frequencies separated by channel width.
- The difference between the physical layer parameters on the source and target DCC channels must be within the threshold required by the desired DCC initialization technique.
- DOCSIS 1.1 must be enabled for a modem to behave properly for the DCC operation. Note that not all DOCSIS 1.1 certified modems are DCC-capable, as the CableLabs DCC ATP tests need enhancement for complete coverage.

## Prerequisites for Dynamic Bonding Change for DOCSIS 3.0 Static Modem Count-Based Load Balancing

- Initialization techniques 1 to 4, when used, require the Cisco CMTS to include the upstream channel descriptor (UCD) TLV (TLV46.5) in the DBC-REQ message.
- Bandwidth must be sufficient on the target bonding group to support DBC. This is determined by the admission control APIs.
- Fiber nodes must be configured before configuring DOCSIS 3.0 static modem count-based load balancing.

# Restrictions

The following sections describe the restrictions applicable for the Load Balancing, Dynamic Channel Change, and Dynamic Bonding Change feature:

## Restrictions for Load Balancing

The Load Balancing feature has the following restrictions:

- Load balancing can be done only on a per-line card basis—all interfaces in a load balancing group must be provided by the same line card.

- All downstreams and upstreams in a load balancing group must share physical connectivity to the same group of cable modems. All downstreams or all upstreams that have the same RF physical connectivity must be members of the same load balancing group.
- You can create a maximum of 256 load balancing groups on each line card.
- If an upstream port is operational, using the **no shutdown** command, and is not being used and not connected, load balancing attempts to use the port even though there are no cable modems registered on that port. When the upstream port is up, it is put into INIT state and load balancing includes this port as a potential target. However, if the load balancing sees multiple failures moving to this upstream, it is set to DISABLE state and the port is avoided later on in load balancing processes.
- The load balancing algorithms assume a relatively even distribution of usage among modems. In the situation where one cable modem creates the bulk of the load on an interface, the load balancing thresholds should be configured for a value above the load created by that single modem.
- You cannot select particular cable modems to be automatically moved for load balancing, although you can exclude cable modems from load balancing operations altogether on the basis of their MAC address or organization unique identifier (OUI). (You can use the **test cable load-balance** command to manually move a particular cable modem among upstreams, but this is done typically to test the configuration of the load balancing groups.)
- If you have configured upstream shared spectrum groups while doing downstream load balancing, the downstream in each MAC domain must not use overlapping upstream groups. For example, the downstream in one MAC domain could use an upstream spectrum band of 10 to 30 MHz, while the downstream in a second MAC domain could use an upstream spectrum band of 30 to 42 MHz. Each MAC domain has its own upstream shared spectrum group, allowing the load balancing group to contain the downstreams for both MAC domains.
- All upstream ports coming from the same splitter must be using different center frequencies that are separated by the channel width. For example, if the upstreams are using a channel width of 3.2 MHz, the center frequencies for all upstreams must be separated by at least 3.2 MHz.
- You can use four initialization techniques for Dynamic Channel Change (DCC).
- If you have configured load balancing, the provisioning system must not assign specific upstream channels or downstream frequencies to individual cable modems in their DOCSIS configuration files. Any cable modems requiring specific upstream channels or downstream frequencies must be excluded from load balancing operations (using the **cable load-balance exclude** command).
- Do not use the utilization method of load balancing on cable interfaces that have a small number of cable modems and where a single modem is responsible for the majority of the interface load. In this condition, the Cisco CMTS could end up continually moving cable modems from one interface to another in an endless attempt to load balance the interfaces. To avoid this, configure the utilization threshold to a value that is higher than what can be caused by any single cable modem.
- When deployed with channel restriction features, if the target upstream channel attribute masks are against that of the cable modem, then the cable modem on the higher load upstream will not be load balanced, as the current load balancing moves cable modems only to the target upstream. However, cable modems that do not have an attribute mask can still be load balanced. You should consider the following while deploying the load balancing groups: the target upstream will always be the upstream that has the lowest load. If some other upstreams have the same load, the upstream with the lowest index will be chosen as the target upstream.
- A TLV in a cable modem configuration file restricts dynamic load balancing on per modem basis.

- If you remove the last rule of a DOCSIS policy, the policy itself will be removed.
- The Cisco CMTS load balancing feature moves a cable modem based on the load of the channels in a load balancing group, without checking if the cable modem supports the extended frequency range (5Mhz-85Mhz). This may result in moving a cable modem that supports standard frequency range (5Mhz-65Mhz) to a channel that has extended frequency configured. To overcome such scenarios, operators should not mix upstreams that have standard and extended frequencies configured into the same load balancing group, unless all modems in the group support extended frequency range.

## Restrictions for Dynamic Channel Change for Load Balancing

- The source and target upstreams and downstreams must share physical connectivity with the modem desired for a DCC transaction.
- Independent downstream change is not supported, and cross-MAC domain upstream changes must occur with the associated downstream changes.
- The source and target downstream interfaces must belong to the same virtual bundle and the same load balancing group if DCC is used for load balancing.
- For DCC initialization techniques 1 to 4, all the configuration variables of the cable modem must remain constant with the exception of the configuration variables that are explicitly changed by the Dynamic Channel Change request (DCC-REQ) messages encoding.
- DCC initialization techniques 2 to 4 must not be used if the propagation delay differences between the old and new channels exceeds the ranging accuracy requirement defined in DOCSIS, for example,  $\pm 0.25$  usec plus  $\pm$  symbol time.

For example, for a symbol rate of 1.28 Msps, the timing offset difference between the source and target upstream channel is  $\pm \text{floor}[(0.250 \text{ us} + 0.5 * 0.781 \text{ us}) / (1/10.24)] = \pm 6$ .

- The attenuation or frequency response differences between the old and new upstream channels causes the received power at the Cisco CMTS to change by more than 6 dB.
- DCC initialization technique 3 must not be used if the conditions for using technique 2 are not met.
- DCC initialization technique 4 must not be used if the conditions for using technique 2 cannot be met.
- Micro-reflections on the new upstream channel result in an unacceptable BER (greater than  $1e-8$ ) with pre-equalization coefficients set to the initial setting.
- DCC is used only for dynamic downstream load balancing on DOCSIS 1.1 and later CMs. Upstream Channel Change (UCC) is always used for dynamic upstream load balancing on DOCSIS 1.x CMs. For DOCSIS 2.x CMs, UCC is used when the *ucc* option is configured. For DOCSIS 3.x CMs, DCC is used irrespective of whether the *ucc* option is configured or not.
- Prolonged interruption of the multicast traffic is expected if the cable modem moved by DCC is the first one in a dynamic multicast group on the target interface. The downstream multicast service flow cannot be reestablished until the Cisco CMTS receives an Internet Group Management Protocol (IGMP) join message from the customer premises equipment (CPE) as the result of the Cisco CMTS IGMP query, where the IGMP query interval is set to one minute. This is an IGMPv2 limitation.
- Multiple statically-assigned IP addresses to a CPE can be pinged. However, this works only if all the security features, such as verification of IP addresses for cable modems and CPE devices on the upstream, and other security mechanism are disabled.

- The TCS and RCS assigned to the DOCSIS 3.0 cable modems are restricted by the upstream and downstream bonding groups configured by the Cisco CMTS.
- Load balancing and DCC are not supported for CMs that are enabled for Layer 2 VPN (L2VPN) support.
- When a DCC occurs, the cable modem US and DS counters are reset. The US and DS counters include counters such as data and throughput seen in the **show cable modem (mac-address) verbose** command output and packets and bytes seen in the **show cable modem (mac-address) counters** command output.

## DCC Restrictions with N+1 Redundancy and Inter-Card Load Balancing

- Inter-card load balancing is not supported with cable interface line cards using N+1 redundancy. Refer to general DCC restrictions for additional information.
- Dynamic load balancing should not be used together with N+1 redundancy. Cable modems with outstanding DCC transactions go offline after a switchover event.



---

**Note** When cable modems go offline during a switchover event, the load balancing feature activates. Cable modems move in relation to the switchover event. When the cable modems return online, load balancing may need to initiate again.

To facilitate load balancing during a switchover, you can increase the dynamic load balance threshold, if a certain percentage of cable modems that reset during switchover is configured in the system. An alternate method is to use static load balancing with N+1 redundancy. For more information, see the [Types of Load Balancing Operations](#).

---

## Restrictions for DOCSIS 3.0 Static Modem Count-Based Load Balancing

- Static modem count-based load balancing is supported on MTC and MRC-only cable modems. Single-channel, narrowband cable modems will continue to be supported with dynamic load balancing. MRC-only modems are supported by dynamic load balancing on upstream channels.



---

**Note** DOCSIS 3.0 static modem count-based load balancing is not supported on:

- Multiple line cards.
  - Load balancing groups and downstream channels shared across multiple line cards.
- 
- DOCSIS 3.0 static modem count-based load balancing does not support service flow method of load balancing.

## Restrictions for Dynamic Bonding Change for DOCSIS 3.0 Static Modem Count-Based Load Balancing

- The Cisco CMTS can use only DBC messaging to move modems within a MAC domain and applies only to cable modems operating in MTC mode or MRC-only mode without a primary downstream change.
- The Cisco CMTS moves the MRC-only cable modems with a primary channel change using DCC with initialization technique 0.
- The Cisco CMTS moves cable modems across MAC domains using only DCC with initialization technique 0.
- The Cisco CMTS must ensure minimum interruption to existing QoS services while considering an initialization technique that is suitable for the cable plant conditions.



---

**Note** DOCSIS 3.0 Static Load Balancing uses Initialization Technique 1 to move cable modems for DBC movement.

---

- Initialization Technique 1—(Broadcast initial ranging) may result in a lengthy interruption of service, which is mitigated by the reservation of QoS resources on the new channel(s). The service interruption can be further reduced if the Cisco CMTS supplies the UCD TLV in the DBC request in addition to providing more frequent initial ranging opportunities on the new channel.
  - Initialization Technique 2—(Unicast ranging) offers the possibility of only a slight interruption of service. To use this technique, the Cisco CMTS must include the UCD TLV in the DBC message if the upstream channel is changing.
  - Initialization Technique 3—(Broadcast or unicast ranging) offers the possibility of only a slight interruption of service. Use this technique when there is uncertainty when the CM may execute the DBC command and thus a chance that it might miss station maintenance slots. However, the Cisco CMTS should not use this technique if the conditions for using techniques 1 and 2 are not completely satisfied.
  - Initialization Technique 4—(Use the new channel directly) results in the least interruption of service.
- For a DOCSIS 3.0 cable modem that in a DOCSIS 3.0 static load balancing group, the multicast join will be dropped before REG-HOLD time elapses.

## Restrictions for MRC-Only Cable Modems

- MRC-only cable modems use single channel non-bonded upstreams (similar to narrowband (NB) modems) and multi-channel bonding groups on the downstream.



---

**Note** The following restrictions apply only to DOCSIS 2.0 and DOCSIS 3.0 cable modems in MRC-only mode.

---

- cable modems are moved across upstream channels using DCC.

- cable modems are moved to different downstream channels through DBC, if there is a change in the upstream channel and downstream channel bonding group, but not in the primary downstream channel and the upstream channel change is ignored.

However, if there is a change in the primary downstream channel also, DCC with init tech 0 is used to balance the cable modems.

- MRC-only modems are treated similar to cable modems operating in MTC mode, to move modems across downstream channels. For change in upstream channel, MRC-only cable modems are treated similar to single-channel NB cable modems.

## Information on the Load Balancing on the Cisco CMTS

This section describes the operation, concepts, and benefits of the Load Balancing on the Cisco CMTS feature:

### Feature Overview

The Load Balancing on the Cisco CMTS feature allows service providers to optimally use both downstream and upstream bandwidth, enabling the deployment of new, high-speed services such as voice and video services. This feature also can help reduce network congestion due to the uneven distribution of cable modems across the cable network and due to different usage patterns of individual customers.

By default, the Cisco CMTS platforms use a form of load balancing that attempts to equally distribute the cable modems to different upstreams when the cable modems register

This feature has been enhanced to make use of DOCSIS policies and rules to limit the movement of cable modems within a Load Balancing Group. A policy defines whether and when cable modems can be moved within their load balancing groups.

A policy consists of a set of rules. Each rule can be defined as “enabled”, “disabled”, or “disabled during time period.” Multiple policies can share a single rule. However, if you remove the last rule of a policy, that will also remove the policy.

Each rule can be used in any number of policies. When it is defined by multiple rules, all rules apply in combinations. Each rule helps to prohibit load balancing using a particular cable modem and to prohibit load balancing using a particular cable modem during certain times of the day.

Following are the general guidelines for the rules and policies:

- The policy or rule is recognized by a 32-bit ID.
- Each cable modem can have one policy only.
- Each rule can be associated to one or more policies.
- Each policy is described by at least one rule, otherwise it cannot be created.
- The zero Policy ID is reserved by Cisco CMTS indicating “Do nothing to LB prohibition.”
- If the policy ID specified by the cable modem configuration file is not configured on Cisco CMTS, no LB prohibition is applied to that CM. However, after the policy with the matched ID is configured, LB prohibition takes effect immediately.

## Methods to Determine When Interfaces Are Balanced

In addition to selecting how interfaces should be balanced (using the static, passive, or dynamic types of load balancing), you can also select one of the following methods that the Cisco CMTS should use to determine when interfaces are balanced:

- **Modems Method**—Uses the number of active cable modems on an interface.
- **Utilization Method**—Uses the current percentage of utilization of an interface.

See the following sections for more information about each method.

### Modems Method

The modem method of load balancing uses the number of active cable modems on an interface to determine the current load. This is a form of distribution-based load balancing, in which the absolute numbers of modems are used to determine whether interfaces are load balanced.

This method does not take into account the amount of traffic flowing through the cable modems, but the system does take into account the relative bandwidth of the channels being used, so that channels with higher bandwidths are allocated higher numbers of cable modems. This means that when interfaces are using different channel widths or modulation profiles, the system can assign different numbers of cable modems to the interfaces to achieve a balanced load. For example:

- **Channel widths**— If two upstreams are being load balanced, and one upstream is configured with a channel width of 1.6 MHz and the other upstream is configured for a channel width of 3.2 MHz, the Cisco CMTS allocates twice as many cable modems to the second upstream because its channel width is twice as large as the first upstream channel width.
- **Modulation profiles**— If one downstream is configured for 64-QAM and the other downstream is configured for 256-QAM, the Cisco CMTS allocates a proportionately larger number of cable modems to the second downstream so as to achieve a balanced load.

When both the channel width and modulation profile are set differently on two interfaces, the system calculates a “weight” value to use as a guide to determine the relative bandwidths of the interfaces.



---

**Tip** In a system with balanced loads, the interfaces will contain the same number of cable modems only when the interfaces are configured with the same channel width and modulation parameters.

---

### Utilization Method



---

**Note** Narrowband cable modems, multiple downstream modems and upstreams of MRC-only cable modems participate in the utilization method.

---

The utilization method uses an interface’s current percentage of utilization to determine the current load. This method uses the amount of traffic being sent over an interface, in the form of the percentage of total bandwidth being used. The system takes into account the relative throughput and bandwidth (as determined by the modulation profiles and channel widths) of each interface when evaluating the load on those interfaces.



For example, if two upstreams are being load balanced using the utilization method, and the first upstream has twice the bandwidth of the second upstream, the two upstreams are considered balanced when they reach the same percentage of utilization. The first upstream is carrying more traffic than the second upstream because it has a larger capacity for traffic, but the percentage of utilization will be the same.

### Wideband Interface Average Utilization and Throughput

The average utilization and average throughput between Wideband interfaces of the same size can be calculated by:

$$\text{Average Utilization (WB)} = \sum_{i=1}^n \text{rfch - util}(\text{rf}_i) / n$$

- $n$  represents the size of the Wideband interface
- $\sum_{i=1}^n \text{rfch - util}(\text{rf}_i)$  represents the sum of rfch - util of QAM channels in Wideband interface.

$$\text{Average Throughput (WB)} = \text{AverageThroughput(WB)} \text{ in last } 30\text{s} / \sum_{i=1}^n \text{BW}(\text{rf}_i)$$

- Average Throughput (WB) represents the KB recorded in the last 30 seconds
- $\sum_{i=1}^n \text{BW}(\text{rf}_i)$  represents the total bandwidth of Wideband interface.



---

**Note** Use the **show cable load-balance load wideband** command to view the average utilization and average throughput between Wideband interfaces.

---

## Load Balancing Parameters

You can determine which cable interfaces should participate in load balancing operations. You can also choose which of the following methods should be used to determine the current load on a cable interface, and therefore determine whether cable modems should be moved:

- Number of active cable modems
- Channel bandwidth utilization

You can also specify the threshold values that the Cisco CMTS should use to determine how to assign new cable modems to upstreams and downstreams for both types of load balancing. You can also configure whether cable modems with active Voice-over-IP (VoIP) calls should be moved, and if so, what thresholds should be used. You can also exclude certain cable modems from one or all of the different forms of load balancing.

### Configurable Minimum Threshold under Utilization Method

The utilization method does not move cable modems for load balancing until the utilization of at least one of the interfaces reaches minimum threshold. This is done to avoid the unnecessary moving of cable modems due to temporary spikes in an interface's utilization rate.

Minimum utilization threshold can be configured under Utilization Method. The minimum utilization threshold may be configured in a range of 10 to 90 percent. As a result the cable modems will be moved only when the configured minimum utilization threshold is reached on an interface.

To configure the minimum threshold under the Utilization method, use the **cable load-balance method-utilization min-threshold** command in global configuration mode. For more information, refer to **cable load-balance method-utilization min-threshold** command reference.

# Single Channel Load Balancing

## Error Handling of Channel Assignment

As long as the interface state of the channels is not "administratively down", all channels are available for LBG assignment. For other load balancing operations, such as moving modems using DCC, or UCC, the interface state of the channels should be in "initial", "up", "suspicious", or "testing" states.

## Downstream Load Balancing Distribution with Upstream Load Balancing

Downstream load balancing provides equalized load balancing with upstream group members. This enhancement synchronizes the "pending" statistic between different cable interface line cards in the load balancing group. The result is an alternative downstream load balancing scheme that makes use of per-upstream loads rather than total downstream loads.

This enhancement performs downstream load balancing that accounts for upstream channel loads in the same upstream load balancing group, rather than on the basis of the entire downstream channel load. Prior Cisco IOS releases may not have distributed cable modems evenly over individual upstream channels, nor in a way that accounted for downstream and upstream together.

The load balancing enhancement applies when downstream load balancing occurs on a headend system with separate upstream load balancing segments; the upstream segments are spread over multiple downstream segments.

The configuration and operation of making downstream load balancing decisions is enabled as follows:

- The target downstream segment is in the same downstream load balancing group as the source downstream segment.
- The upstream load balancing group can be set for the corresponding channel on which a cable modem is balanced.
- The Cisco CMTS automatically locates the upstream segment for a load balancing group and processes the upstream group status on the source interface that has the lowest load.
- The target downstream segment must have an upstream channel set in the upstream load balancing group.
- The highest target upstream segment must carry less load than any other potential target—the highest upstream segment on other interfaces.

For example, several upstream segments can be configured across multiple downstream segments as follows:

	U0	U1	U2	U3	Downstream
3/0	LB10	LB11	LB12	LB13	LB1
4/0	LB10	LB11	LB12	LB13	LB1
5/0	LB10	LB11	LB12	LB13	LB1
6/0	LB10	LB11	LB12	LB13	LB1

In this example, a cable modem that comes online on the interface cable 5/0 Upstream 2 could potentially come online on the following interfaces:

- cable 3/0 upstream 2
- cable 4/0 upstream 2
- cable 6/0 upstream 2

The enhancement enables the following advantages and behaviors:

- This enhancement adds support for synchronizing the “pending” statistic between different cable interface line cards and the network processing engine (NPE) so that a better decision can be made about where cable modems should be moved. This function can be used as a normal downstream load balancing implementation, if desired.
- This enhancement adds the **us-groups-across-ds** keyword to **cable load-balance group** command for configuring downstream load balancing groups with upstream resources.



---

**Note** You can use the **no cable load-balance docsis20-enable** command to disable DOCSIS 2.0 dynamic downstream and upstream load balance.

---

## Upstream Load Balancing for DOCSIS 3.0 Cable Modems in Single Upstream Mode

The upstream load balancing functionality enables the Cisco CMTS router to effectively handle upstream traffic for wideband and narrowband cable modems that are in single upstream mode. Single upstream mode (Mx1) means that the modems cannot send upstream traffic on multiple upstream channels. In the event of traffic overload on a single upstream channel of a wideband or narrowband cable modem, the Cisco CMTS router automatically moves the cable modem to another upstream channel in the same load balancing group.



---

**Note** A cable modem operating in single upstream mode is assigned to a load balancing group based on the primary channel of the modem. A cable modem in single upstream mode can support multiple receive channel (MRC) mode or narrowband mode. However, a cable modem in single upstream mode cannot support multiple transmit channel mode (MTC).

---

## Interaction with Spectrum Management

Cisco cable interface line cards support a number of features to maximize channel bandwidth and to minimize the impact of ingress noise on cable modem traffic. These features have the following impacts upon load balancing operations:

- Frequency hopping—Frequency hopping does not affect the load balancing algorithm, because it does not change either the bandwidth of a channel nor the number of cable modems on an interface.
- Dynamic modulation changes—The dynamic modulation feature affects the load balancing algorithm because it typically switches an interface from a higher-bandwidth modulation profile to a lower-bandwidth modulation profile in response to noise conditions on the interface.

For example, if an upstream is configured for 16-QAM, sufficient noise levels could switch the upstream to a QPSK modulation profile. Depending on the load balancing configuration, this could then result in the movement of cable modems to other channels. Similarly, when the noise conditions improve, and the modulation is returned to the original, higher-bandwidth profile, the cable modems could be moved again to rebalance the upstream channels.

- Channel width changes—Cisco cable interface line cards support automatic changes to the channel width in response to noise conditions. Because changing the channel width affects the throughput of a channel, this also affects the load balancing algorithm.

For example, if noise makes the current channel width unusable, the Cisco cable interface line card reduces the channel width until it finds a usable channel width. Because this reduces the available bandwidth on the channel, the load balancing algorithm moves cable modems to rebalance the upstreams.

In addition, the Cisco cable interface line card does not automatically restore the original channel width when noise conditions improve. Instead, the card changes the channel width only when it performs a subsequent frequency hop, either in response to additional noise conditions or when an operator performs a manual frequency hop. When the hop occurs, the card then searches for the largest possible channel width, and this could result in another movement of cable modems to rebalance the channels.

## Using Dynamic Channel Change

DCC in DOCSIS 1.1 dynamically changes cable modem upstream or downstream channels without forcing a cable modem to go offline, and without re-registration after the change. DCC supports five different initialization methods (0-4).

- Load balancing techniques allow for moving cable modems with DCC by using configurable initialization techniques.
- DCC allows line card channel changes across separate downstream channels in the same cable interface line card, with the DCC initialization techniques ranging from 0 to 4.
- DCC transfers cable modem state information from the originating downstream channel to the target downstream channel, and maintains synchronization of the cable modem information between the cable interface line card and the Network Processing Engine (NPE) or Route Processor (RP).
- Applications that are sensitive to delay, such as PacketCable (PC) and PacketCable Multi Media (PCMM), may use DCC initialization technique4 to retain services while the cable modem is performing DCC.
- If the channel is in mixed or ATDMA-only mode, the primary Service Identifier (SID) must be switched to ATDMA-only mode.



---

**Note** You can use the **no cable load-balance docsis20-enable** command to disable DOCSIS 2.0 dynamic downstream and upstream load balance.

---

## Multiple Channel Load Balancing

### Algorithm for Bonded Channel Cable Modem Load Balancing

During registration of the cable modem, the modem count-based method uses the number of active cable modems on the allowed RCS to determine the current load on each channel. After the modem is assigned an RCS, the Cisco CMTS does not move the cable modem even when traffic conditions change.

When a cable modem sends a registration request, modem count-based method of load balancing ranks the allowed receive channel sets (RCS) based on their modem count and assigns the set with the lowest number of CMs, to the ranging cable modem.

### DOCSIS 3.0 Static Modem Count-Based Load Balancing

The static modem count-based load balancing supports the following:

- DOCSIS General and Restricted load balancing group assignment to include DOCSIS 3.0 cable modems in MTC and MRC-only modes.



---

**Note** DOCSIS 3.0 static modem count-based load balancing is not supported:

- Across multiple line cards.
  - For load balancing groups and downstream channels shared across multiple line cards. However, autonomous load balancing-based CM steering and load balancing group assignment is supported across multiple line cards
- 
- Use of DCC and DBC in load balancing.
  - Use of DBC for MRC-only modems during downstream move.
  - Use of DCC with init tech 0 if the primary downstream channel is changed for MRC-only CMs.
  - Use of DBC for cable modems in MTC mode for all upstream and downstream modem move.
  - Separate counters for NB and wideband (WB)/upstream bonding (UB) CMs. For more information, see the **show cable load-balance docsis-group** command in the [Cisco IOS CMTS Cable Command Reference](#).
  - Aggregate logical channels to physical channels for load balancing. Physical channel load is calculated by using average weights among all logical channels.
  - Non-primary downstream channels load where utilization of SPA QAM is considered



---

**Note** When the CM counts across different WB interfaces are within predefined threshold levels, the load is always considered as balanced; no more CM move is initiated by the LB system. No service flow count, whether primary or secondary, is taken into consideration during this LB process.

---



---

**Note** The attributes considered for the forward interface for the service flow (SF) are attribute mask and available bandwidth, and *not* the number of service flows on each channel. If a channel is within the new RCS, then irrespective of the type of narrowband SF, (whether primary or secondary, or static or dynamic) the SF continues to use its current channel.

---



---

**Note** The US Phy Mode counters (scdma, atdma, and tdma) remain 0 for the UB interfaces.

---

DOCSIS 3.0 static modem count-based load balancing is based on legacy load balancing and supports any type of channel combination (upstream and downstream)—MxN, with 1x1 combination being the subset.

DOCSIS 3.0 static modem count-based load balancing controls dynamic changes to the set of downstream and upstream channels used by a registered CM. It supports the following:

- Multiple channel load balancing operation.
- Load balancing operation based on policies and priorities.

- Load balancing with multicast. DOCSIS 3.0 static modem count-based load balancing does not move any CM with active video sessions.

DOCSIS 3.0 static modem count-based load balancing supports the modem count-based load balancing in a hybrid deployment of DOCSIS 1.x, 2.0 and 3.0 cable modems.

Static modem count-based load balancing is supported only for DOCSIS 3.0 CMs. Single-channel, narrowband cable modems will continue to be supported with dynamic load balancing. MRC-only cable modems are supported by dynamic load balancing on upstream channels.

With DOCSIS 3.0 static modem count-based load balancing, when load balancing related configuration within the LBG is changed as follows, the cable modems are forced to re-register:

- Partial shut or no shut interfaces under the LBG domain
- MRC or MTC mode in cable modems is turned on or turned off
- Change in fiber node for GLBG
- Change in wideband configuration for downstream group
- Change in the upstream bonding group

Use the following commands to force cable modems to re-register:

- **clear cable modem delete**
- **clear cable load state**
- **clear cable load counters**

### Primary Channel Load Display for Target RCS

This feature enables the bonded modems to be moved at the time of registration such that the primary channels are distributed evenly among the primary-capable channels apart from the load being balanced on the target DS channels. Modem method ranks the RCS based on their primary loads and assigns the set with the lowest primary load to the ranging cable modem.

An optional keyword **primary-load** has been added to the **show cable load-balance docsis-group** command to display the primary load of an RCS. For more information, see the [Cisco CMTS Command Reference](#).

Although the modem count-based method distributes the cable modems fairly as they register, the following conditions may cause a system imbalance:

- A channel or groups of channels fail because of a planned (administrative shutdown) or unplanned event.
- While some cable modems may continue to operate in partial mode, some may re-register because of the failure and are reassigned to the channels that are active.
- When the failed channels become operational again, the cable modems do not re-register and the system is unbalanced.

In this case, the modem count-based method sends an SNMP trap to alert the operator, and the operator can choose to manually intervene to re-balance the cable modems by resetting the MAC domain to force all cable modems to re-register.



---

**Note** For cable modems in MRC and MTC modes, the modem count based load balancing method considers the number of active modems and service flows on the primary channels in the RCS and TCS of the cable modem.

---



---

**Note** Use **no cable load-balance docsis30-enable static** command to disable this feature.

---

## Dynamic Load Balancing for DOCSIS 3.0 Cable Modems

The existing Load Balancing (LB) feature is enhanced to cope with the increase in the number of downstream and upstream channels by Multi-Service Operators (MSO) and wider deployment of 16-channel, 24-channel and multiple downstream channel Cable Modems (CMs). This enhancement allows the customer to better utilize their available bandwidth. The enhancements made to the existing LB feature include:

- Utilization based Dynamic downstream LB for DOCSIS 3.0
- Support for DOCSIS 3.0 LB statistics
- Enable or Disable DOCSIS 3.0 LB feature
- Distribute the CM on all the primary channels for the target interface when performing DOCSIS 3.0 LB dynamic movement. This feature is only used on DOCSIS 3.0 LB dynamic movement. It is disabled by default. Use **method utilization primary-distributed** command in the DOCSIS load balancing group mode to enable this feature. To disable this feature, use **no** form of this command or **method utilization us-method** command.



---

**Note** Use **cable load-balance docsis-enable** command to enable this feature. In addition, use **cable load-balance docsis30-enable** and **cable load-balance docsis30-enable dynamic downstream** command to enable dynamic and utilization based dynamic downstream LB for DOCSIS 3.0 Cable Modems.

---

## Multiple Channel Load Balancing Operation

CMs load balance in MRC and MTC modes. The following rules apply while load balancing CMs operating in these modes:

- For CMs operating in MRC and MTC modes, DBC is used to move CMs across downstreams by changing the RCS of the CM within same MAC domain.

CMs operating in MRC-only mode can be moved across upstreams only through a DCC request. However, the Cisco CMTS uses DCC with initialization technique 0 (reinitializing the MAC domain) when changing the downstream channel of a CM operating in MRC mode.

- During CM registration, the Cisco CMTS may send a multipart registration response (REG-RSP-MP) message to include a TCC TLV encoding to the CM. This CM is marked as TCC-capable.

For CMs operating in MRC, non-MTC, non-TCC-capable mode, load balancing uses:

- DBC to change RCS of the CM
- DCC to change upstream channel of the CM
- For CMs operating in narrowband mode, DCC is used to move CMs within and across MAC domains.

The tables below provide a snapshot view of the load balancing methods and the operations used to move bonded and non-bonded CMs:

**Table 52: Load Balancing Method to Move Bonded and Non-bonded CMs**

Modem Mode	Load Balancing Method	Load Balancing Counters	Channels	Dynamic Service Charge (Initialization Technique)	
				Within MAC Domain	Across MAC Domains
DOCSIS 3.0 CM in MTC mode	DOCSIS 3.0 static modem count-based load balancing (MCBLB)  DOCSIS 3.0 dynamic load balancing	WB/UB	DS	DBC  <b>Note</b> When DOCSIS 3.0 LB is enabled, and the MTC CM is outside RLBG, CM is moved inside RLBG.	DCC init tech 0
	DOCSIS 3.0 static modem count-based load balancing (MCBLB)	WB/UB	US	DBC  <b>Note</b> When DOCSIS 3.0 LB is enabled, and the MTC CM is outside RLBG, CM is moved inside RLBG.	DCC init tech 0



Modem Mode	Load Balancing Method	Load Balancing Counters	Channels	Dynamic Service Charge (Initialization Technique)	
DOCSIS 3.0/D2.x CMs in MRC-only mode	DOCSIS 3.0 static MCBLB  DOCSIS 3.0 dynamic load balancing	WB/UB	No change to the primary DS channel	DBC  <b>Note</b> When DOCSIS 3.0 LB is enabled and CM with all DSs is outside RLBG, CM is moved inside RLBG.	DCC init tech 0
			Change to the primary DS channel	DCC init tech 0  <b>Note</b> CM with primary DS outside RLBG moves inside RLBG with DOCSIS 2.0 LB.	DCC init tech 0
DOCSIS 3.0 CMs in MRC-only mode	DOCSIS 2.0 static and dynamic MCBLB, dynamic utilization	NB	US	DCC  <b>Note</b> CM outside RLBG moves inside RLBG with DOCSIS 2.0 LB.	DCC init tech 0

Modem Mode	Load Balancing Method	Load Balancing Counters	Channels	Dynamic Service Charge (Initialization Technique)	
D2.x CMs in MRC-only mode	DOCSIS 2.0 static and dynamic MCBLB, dynamic utilization	NB	US	DCC/UCC <b>Note</b> CM outside RLBG moves inside RLBG with DOCSIS 2.0 LB.	DCC init tech 0
DOCSIS 2.0 /DOCSIS 1.1 CMs in NB mode	DOCSIS 2.0 dynamic MCBLB, dynamic utilization	NB	DS	DCC <b>Note</b> CM outside RLBG moves inside RLBG with DOCSIS 2.0 LB.	DCC init tech 0
			US	UCC <b>Note</b> CM outside RLBG moves inside RLBG with DOCSIS 2.0 LB.	UCC

Modem Mode	Load Balancing Method	Load Balancing Counters	Channels	Dynamic Service Charge (Initialization Technique)	
DOCSIS 1.0 in NB mode	DOCSIS 2.0 dynamic MCBLB, dynamic utilization	NB	DS	Force reinitialize CM <b>Note</b> CM outside RLBG moves inside RLBG with DOCSIS 2.0 LB.	Force reinitialize CM
			US	UCC <b>Note</b> CM outside RLBG moves inside RLBG with DOCSIS 2.0 LB.	UCC

Table 53: Using DCC/DBC to Load Balance Bonded and Non-bonded Cable Modems

Channel	CM in MRC, MTC Mode	CM in MRC, non-MTC Mode	DOCSIS 1.1/2.0 CMs with Single US/DS	DOCSIS 1.0 CMs with Single US/DS
Upstream (US)	DBC	DCC	DCC	UCC
Downstream (DS)	DBC (within the same MAC domain)	DBC (within the same MAC domain)	DCC (within the same MAC domain)	Force reinitialize CM
	DCC with initialization technique 0 when moving CMs across MAC domains	DCC with initialization technique 0 when moving CMs across MAC domains	DCC with initialization technique 0 when moving CMs across MAC domains	Force reinitialize CM

### Using DBC for DOCSIS 3.0 Load Balancing Movement

As part of the DOCSIS 3.0 specifications, at any time after registration, the Cisco CMTS uses the DBC command to change any of the following parameters in a DOCSIS 3.0 CM:

- Receive channel set
- Transmit channel set

- DSID(s) or DSID associated attributes
- Security association(s) for encrypting downstream traffic
- Service Flow Cluster Assignments



---

**Note** Only RCS and TCS are used by the DOCSIS 3.0 load balancing.

---

Use the **show cable load-balance docsis-group** command to display the current, real-time statistics for load balancing operations. For more information, see the [Cisco IOS CMTS Cable Command Reference](#).

### Using DBC to Change the Receive Channel Set

The Cisco CMTS can add, delete, or change the channels in the RCS of a cable modem by including a RCC in the DBC-REQ.

If an RCS change affects the primary downstream channel of the cable modem, the cable modem is required to re-register on its upstream channels.

If channels are deleted from the RCS, the Cisco CMTS may stop sending traffic on the downstream channel to be removed, which may cause loss of traffic. The Cisco CMTS minimizes packet loss by duplicating traffic on the new and old RCS until it receives a DBC-RSP from the cable modem.



---

**Note** For cable modems in MRC-only mode, a downstream channel move is initiated by a DBC message. However, DCC initialization technique 0 is used if there is a change in the primary downstream channel.

---

### Using DBC to Change the Transmit Channel Set

The Cisco CMTS can add, delete, or replace one or multiple channels in the TCS in a single DBC message. Whenever the TCS of the cable modem changes, the CMTS appropriately modifies the service identifiers (SIDs) associated with the affected service flows.

A change in the TCS is accompanied by a valid initialization technique.

### Using DBC to Change the Downstream ID

Using DBC, the Cisco CMTS can change the following attributes of a downstream ID (DSID):

- Re-sequencing encodings:
  - Downstream re-sequencing channel list—The CMTS can add, delete, and replace channels in the DS re-sequencing channel list.
  - DSID re-sequencing wait time—The CMTS can indicate a change in skew due to network or configuration changes through DSID re-sequencing wait time.
- re-sequencing Warning Threshold
- CM-STATUS Hold-Off Timer for Out-of-range Events
- Multicast Encoding—The CMTS can initiate a DBC transaction to either add, deleted, or change attributes of an existing multicast DSID:

- Client MAC Address
- Multicast cable modem interface Mask
- Group MAC Address

### Using DBC to Change the Security Association for Encrypting Downstream Traffic

- The CMTS can initiate a DBC transaction to add or delete Security Associations (SA) used to encrypt downstream traffic.
- The CMTS cannot send a DBC request to a cable modem that is not in the "Authorized" State.
- The CMTS can send a DBC request with an SA that uses a cryptographic suite unsupported by the cable modem. However, if the cable modem receives a DBC request with an SA that it is not capable of using, the cable modem rejects the DBC request.

### Using DBC to Change the Service Flow SID Cluster Assignments

The Cisco CMTS uses the Service Flow SID Cluster Assignments TLV in the DBC request to assign new channels to a service flow, remove channels from a service flow, or replace one channel with another for a service flow.



---

**Note** Multiple actions can occur within a single DBC message.

---

## Benefits of Load Balancing

The Load Balancing feature on the Cisco CMTS provides the following benefits to cable service providers and their partners and customers:

- Provides a method that service providers can use for efficient bandwidth utilization, especially when using multiple upstream channels per fiber node.
- Allows service providers to expand their networks in an efficient manner, avoiding the cost of having to install additional fiber optic equipment and further segmenting the physical plant.
- Load balancing on downstream channels enables efficient bandwidth usage when using multiple downstream channels per fiber node to enable Video over IP and other services that require high-bandwidth real-time streams.
- Load balancing of upstream and downstream channels does not require any change to the provisioning servers or to any DOCSIS configuration files.
- Load balancing of upstream and downstream channels does not require any administrator or user intervention (such as manually resetting cable interfaces or manually rebooting cable modems).
- Allows service providers to equally balance their downstreams as cable modems register, so that cable modems do not all attempt to register on the same downstream, resulting in many cable modems failing to register and having to search for a new downstream.
- Cable modems can be moved among downstream and upstream channels without having to change any network parameters in manual fashion, such as IP address.

- Allows service providers to stay ahead of customers' bandwidth demands by dynamically responding to current load-usage conditions.
- Allows service providers to optimize the load balancing parameters for critical services, such as Voice over IP (VoIP).

## Exclude Cable Modems from Load Balancing Groups

### Load Balancing Process

The load balancing process has two phases.

- Assignment phase.

When a modem is coming online in the assignment phase, the modem is moved to the load balance group by assigning it a load balancing group (LBG) ID. The assignment phase occurs only when a modem is coming online.

- Balancing phase.

In the balancing phase, a modem is re-assigned to an LBG to balance the load.

### Excluding Cable Modems from Load Balancing

There are four options that are used to exclude cable modems from an LBG:

- The **assignment** option:

The **assignment** option is used to exclude a modem during the assignment phase. The modem is not assigned an LBG and LBG ID is not displayed in the output of the **show cable modem verbose** command. The **assignment** option cannot be used when a modem is already online.

- The **static** option:

The **static** option is used to exclude a modem during the Balancing phase. The modem is assigned to an LBG with an LBG ID. The **static** option is used to exclude a modem during static load balancing.

- The **enforce** option:

The **enforce** option is similar to the **static** option, except that the **enforce** option is used to exclude a modem during dynamic load balancing.

When a cable modem is excluded from load balancing using the **assignment** option, the cable modem is not available for load balancing using the **static** or the **enforce** options.

- The **strict** option:

The **strict** option excludes a modem in both the phases of load balancing. When a modem is online already, the **strict** option applies the **static** and the **enforce** options. It applies the **assignment** option only when the modem comes online again.

## How to Configure Load Balancing

To configure load balancing groups, and to enable load balancing, refer to the configurations in the *DOCSIS Load Balancing Groups* document. Each task is marked as required or optional, as appropriate.

## Enabling Single Channel Load Balancing

To configure Single Channel Load Balancing, see the *DOCSIS Load Balancing Groups guide*.

## Configuring Dynamic Bonding Change for DOCSIS 3.0 Static Load Balancing

Use the **cable load-balance docsis30-enabled** command in the global configuration mode, to enable DOCSIS 3.0 Static Load Balancing.



---

**Note** DOCSIS 3.0 Static Load Balancing always uses Modem Count Method for load balancing.

---

### Before you begin

Configure Load Balancing Groups. For more details, see the *DOCSIS Load Balancing Groups guide*.

## Excluding Cable Modems from a Load Balancing Group

This configuration is optional. This section describes how to exclude a particular cable modem, or all cable modems from a particular vendor, from participating in static or dynamic load balancing operations, and optionally marking the modems for passive load balancing. This task is optional, because, by default, cable modems on an interface participate in whatever load balancing operations have been configured.



---

**Note** This step might be required for some cable modems that are not DOCSIS-compliant. Such cable modems can go offline for long periods of time when load balancing is attempted using DOCSIS MAC messages. If this is the case, use the **cable load-balance exclude** command to exclude such cable modems from load balancing operations until the modem can be upgraded to DOCSIS-compliant software.

---



---

**Tip** You must exclude cable modems that require specific upstream channels or downstream frequencies. Load balancing cannot be done when cable modems are assigned specific channels or frequencies in their DOCSIS configuration files.

---

### Support for Excluding Old Devices

Load balancing for old cable devices like Set Top Boxes (STBs) which do not support load balancing, will fail. In the output for **show cable load-balance group** command, these devices will show as 'suspicious' and then as 'disabled'. This will disrupt normal operations of other modems in the load balancing group. To exclude these STBs, a **cable load-balance exclude** command is configured to exclude each STB.



**Note** You can configure the **cable load-balance exclude** command once to exclude all the STBs, that do not support load balancing, instead of configuring the command several times with matched MAC addresses. You can also move cable modems that were moved to a load balancing group in assignment phase.

The **cable load-balance exclude** modem command is modified to include the *mask* argument as an optional argument. The MAC address of a cable modem that belongs to the range specified by the MAC address mask, will be excluded by matching the “1” bit in mask. While configuring a new range rule using the *mask* argument, an existent rule with the same range is overwritten.

The **cable load-balance exclude** modem command is modified to include the **assignment** option. This option allows you to exclude a cable modem that was moved into a load balancing group in assignment phase.

### Procedure

	Command or Action	Purpose
<b>Step 1</b>	<b>enable</b> <b>Example:</b> Router> <b>enable</b>	Enables privileged EXEC mode. Enter your password if prompted.
<b>Step 2</b>	<b>configure terminal</b> <b>Example:</b> Router# <b>configure terminal</b>	Enters global configuration mode.
<b>Step 3</b>	<b>cable load-balance exclude</b> { <b>modem</b> <i>mac-address</i> [ <i>mac-mask</i> ]   <b>oui</b> <i>oui-value</i> } [ <b>assignment</b>   <b>enforce</b>   <b>static</b>   <b>strict</b> ] <b>Example:</b> Router(config)# <b>cable load-balance exclude</b> oui 00:00:0c	Specifies that one or more cable modems should be excluded from load balancing operations.  By default, the cable modems are excluded from dynamic and static load balancing, but they continue to participate in passive load balancing. Use the following options to exclude the cable modems from others combinations of load balancing:
<b>Step 4</b>	<b>exit</b> <b>Example:</b> Router(config)# <b>exit</b>	Exits global configuration mode.

## Distributing Downstream Load Balancing with Upstream Load Balancing

Two commands are used to configure or display the configuration and status of distributed load balancing on the Cisco CMTS:

- **cable load-balance group** *ds-lb-group-id* **policy** {**pcmm** | **ugs** | **us-groups-across-ds**}
- **show cable load all**

The optional configuration of making downstream load balancing decisions is enabled as follows:



- The target downstream segment is in the same downstream load balancing group as the source downstream segment. This feature finds the target frequency and interface based on the upstream loads within the same upstream group as the source.
- The upstream load balancing group can be set for the corresponding channel on which a cable modem is balanced on the downstream channels.
- The Cisco CMTS automatically locates the upstream segment for a load balancing group and processes the upstream group status on the source interface that has the lowest load.
- The target downstream segment must have an upstream channel set in the upstream load balancing group.
- The highest target upstream segment must carry less load than any other potential target—the highest upstream segment on other interfaces.

### Procedure

	Command or Action	Purpose
Step 1	<b>enable</b> <b>Example:</b> Router> <b>enable</b>	Enables privileged EXEC mode. Enter your password if prompted.
Step 2	<b>configure terminal</b> <b>Example:</b> Router# <b>configure terminal</b>	Enters global configuration mode.
Step 3	<b>cable load-balance group</b> <i>ds-lb-group-id</i> <b>policy</b> { <b>pcmm</b>   <b>ugs</b>   <b>us-groups-across-ds</b> } <b>Example:</b> Router(config)# <b>cable load-balance group 1 policy us-groups-across-ds</b>	Sets the type of service flow policy for use with Load Balancing. This command synchronizes the pending statistic between different cable interface line cards in the load balancing group. The result is an alternative downstream load balancing scheme that makes use of per-upstream loads rather than total downstream loads when making load balancing decisions.
Step 4	<b>exit</b> <b>Example:</b> Router(config)# <b>exit</b>	Exits global configuration mode.
Step 5	<b>show cable load all</b> <b>Example:</b> Router# <b>show cable load all</b>	Displays load balancing statistics and status of load balancing configurations on the Cisco CMTS, to include distributed upstream-to-downstream load balancing when configured.

## How to Configure Dynamic Channel Change for Load Balancing

DCC in DOCSIS 1.1 dynamically changes cable modem upstream or downstream channels without forcing a cable modem to go offline, and without reregistration after the change. DCC supports five different initialization methods (0-4), instead of one, as in earlier DOCSIS support.

Dynamic Channel Change (DCC) and DCC for Load Balancing on the Cisco CMTS supports the following:

- Load balancing techniques allow for moving cable modems with DCC by using configurable initialization techniques.
- DCC allows line card channel changes across separate downstream channels in the same cable interface line card, with the DCC initialization techniques ranging from 0 to 4.
- DCC transfers cable modem state information from the originating downstream channel to the target downstream channel, and maintains synchronization of the cable modem information between the cable interface line card and the Network Processing Engine (NPE) or Route Processor (RP).
- Applications that are sensitive to delay, such as PacketCable (PC) and PacketCable MultiMedia (PCMM), may use DCC initialization technique 4 to retain services while the cable modem is performing DCC.
- If the channel is in mixed or ATDMA-only mode, the primary Service Identifier (SID) must be switched to ATDMA-only mode.

## Configuring Dynamic Channel Change for Load Balancing

To configure the DCC feature for load balancing, use the following steps. Values indicated are sample values that may differ from your own.

### SUMMARY STEPS

1. **enable**
2. **configure terminal**
3. **cable load-balance docsis-enable**
4. **cable load-balance docsis-group** *docsis-group-id*
5. **init-tech-list** *tech-list* [**ucc**]
6. **policy** {**pcmm** | **ugs** | **us-across-ds** | **pure-ds-load**}
7. **threshold** {**load** {**minimum** <1-100> | <1-100>} | **pcmm** <1-100> | **stability** <0-100> | **ugs** <1-100>} }
8. **end**

### DETAILED STEPS

	Command or Action	Purpose
<b>Step 1</b>	<b>enable</b> <b>Example:</b> Router> <b>enable</b>	Enables privileged EXEC mode. Enter your password if prompted.
<b>Step 2</b>	<b>configure terminal</b> <b>Example:</b> Router# <b>configure terminal</b>	Enters global configuration mode.
<b>Step 3</b>	<b>cable load-balance docsis-enable</b> <b>Example:</b> Router(config)# <b>cable load-balance docsis-enable</b>	Enables DOCSIS load balancing on the Cisco CMTS.

	Command or Action	Purpose
Step 4	<b>cable load-balance docsis-group</b> <i>docsis-group-id</i> <b>Example:</b> <pre>Router(config)# cable load-balance docsis-group 1</pre>	Creates a DOCSIS load balance group on the Cisco CMTS, with the following parameter:  The router enters DOCSIS load balancing group configuration mode.
Step 5	<b>init-tech-list</b> <i>tech-list</i> [ <b>ucc</b> ] <b>Example:</b> <pre>Router(config-lb-group)# init-tech-list 1 ucc</pre>	Sets the DCC initialization techniques that the Cisco CMTS can use to load balance cable modems.
Step 6	<b>policy</b> { <b>pcmm</b>   <b>ugs</b>   <b>us-across-ds</b>   <b>pure-ds-load</b> } <b>Example:</b> <pre>Router(config-lb-group)# policy us-across-ds Router(config-lb-group)# policy ugs Router(config-lb-group)# policy pure-ds-load</pre>	Selects the modems based on the type of service flow that are balanced.
Step 7	<b>threshold</b> { <b>load</b> { <b>minimum</b> <1-100>   <1-100>}   <b>pcmm</b> <1-100>   <b>stability</b> <0-100>   <b>ugs</b> <1-100>} <b>Example:</b> <pre>Router(config-lb-group)# threshold load minimum 10 Router(config-lb-group)# threshold pcmm 70 Router(config-lb-group)# threshold load 10 Router(config-lb-group)# threshold stability 50 Router(config-lb-group)# threshold ugs 70</pre>	Selects the percentage of use beyond which load balancing occurs.
Step 8	<b>end</b> <b>Example:</b> <pre>Router# end</pre>	Returns to privileged EXEC mode.

### What to do next

To test and verify DCC for load balancing, use the following two commands:

- **test cable dcc**
- **show controllers cable**

These commands are described in the *Cisco CMTS Cable Command Reference* .

## Verifying Load Balancing Operations

This section describes how to use certain test and show commands to verify the configuration and operation of the Load Balancing feature or Dynamic Channel Change feature on the Cisco CMTS.

## Example

## Procedure

	Command or Action	Purpose
<b>Step 1</b>	<b>enable</b> <b>Example:</b> Router> <b>enable</b>	Enables privileged EXEC mode. Enter your password if prompted.
<b>Step 2</b>	<b>show cable load-balance [group n] [all   load   pending   statistics   target]</b> <b>Example:</b> Router# <b>show cable load-balance group 1</b>	Displays real-time statistical and operational information for load balancing operations. If given without any options, this command displays information for the load balancing groups and each cable interface's current load and load balancing status. You can also specify the following options:
<b>Step 3</b>	<b>test cable dcc [mac-addr   ip-addr   cable-if-src sid   cable-if-target uschan {ranging-tech}]</b> <b>Example:</b> Router# <b>test cable dcc 0000.394e.4e59</b>	Tests Dynamic Channel Change (DCC) by moving a target cable modem, as specified by MAC address, IP address, or the primary service ID (SID) value. Applies to a cable modem on the source interface to an upstream channel on a target downstream interface using the initialization technique specified.

## Example

This example shows the result of load balancing operations.

```

Router#show cable load all
DOCSIS 2.0 LB Enabled: Yes DOCSIS 3.0 LB Enabled: No
DOCSIS      Status Interval DCC mask Policy      Method Threshold
Group
1           RE      30      0xF8 (0)/N 0      m/m      5/10/70/70/50
12345      GE      30      0xF8 (0)/N 0      m/m      5/10/70/70/50
12346      RE      30      0xF8 (0)/N 0      m/m      5/10/70/70/50
12347      RE      30      0xF8 (0)/N 0      m/m      5/10/70/70/50
12348      RE      30      0xF8 (0)/N 0      m/m      5/10/70/70/50
12349      RE      30      0xF8 (0)/N 0      m/m      5/10/70/70/50

DOCSIS 3.0 General LB
MD          FN Group ID   S Intv DCC mask Policy      Mtd MD-CM-SG Threshold
D/U
Ca8/0/0    1   2147631104 E 30   0x30 (2)/N 0      m/m 0x1200301 5/10/70/70/50
Ca8/0/1    3   2147631618 E 30   0x30 (2)/N 0      m/m 0x1210301 5/10/70/70/50
Ca8/0/2    5   2147632132 E 30   0x30 (2)/N 0      m/m 0x1220401 5/10/70/70/50
Ca8/0/2    6   2147632133 E 30   0x30 (2)/N 0      m/m 0x1220402 5/10/70/70/50
Ca8/0/3    7   2147632646 E 30   0x30 (2)/N 0      m/m 0x1230501 5/10/70/70/50
Ca8/0/3    8   2147632647 E 30   0x30 (2)/N 0      m/m 0x1230502 5/10/70/70/50
Ca8/0/8    2   2147635201 E 30   0x30 (2)/N 0      m/m 0x1280201 5/10/70/70/50
Ca8/0/9    4   2147635715 E 30   0x30 (2)/N 0      m/m 0x1290201 5/10/70/70/50

Current load:

DOCSIS load-balancing load
Interface      State Group      Utilization      Rsvd NBCM WB/UB Weight
Total Total
In8/0/0:0(411 MHz) initial 1          0%(0%/0%)        0% 0 11 37
In8/0/0:0(411 MHz) initial 2147631104 0%(0%/0%)        0% 0 11 37
Us8/0/0:0      initial 1          0%                0% 0 31 30.7
Us8/0/0:0      initial 2147631104 0%                0% 0 31 30.7
Us8/0/0:1      initial 1          0%                0% 0 31 30.7

```

Us8/0/0:1	initial	2147631104	0%	0%	0	31	30.7
Us8/0/0:2	initial	2147631104	0%	0%	0	31	30.7
Us8/0/0:2	initial	1	0%	0%	0	31	30.7
Us8/0/0:3	initial	2147631104	0%	0%	0	31	30.7
Us8/0/0:3	initial	1	0%	0%	0	31	30.7
In8/0/0:4 (435 MHz)	up	2147635201	0% (0%/0%)	0%	48	11	37
Us8/0/1:0	up	2147635201	0%	0%	15	0	30.7
Us8/0/1:1	up	2147635201	0%	0%	11	0	30.7
Us8/0/1:2	up	2147635201	0%	0%	11	0	30.7
Us8/0/1:3	up	2147635201	0%	0%	11	0	30.7
In8/0/0:8 (459 MHz)	initial	1	0% (0%/0%)	0%	0	9	37
In8/0/0:8 (459 MHz)	initial	2147631104	0% (0%/0%)	0%	0	9	37
Us8/0/0:0	initial	1	0%	0%	0	31	30.7
Us8/0/0:0	initial	2147631104	0%	0%	0	31	30.7
Us8/0/0:1	initial	1	0%	0%	0	31	30.7
Us8/0/0:1	initial	2147631104	0%	0%	0	31	30.7
Us8/0/0:2	initial	2147631104	0%	0%	0	31	30.7
Us8/0/0:2	initial	1	0%	0%	0	31	30.7
Us8/0/0:3	initial	2147631104	0%	0%	0	31	30.7
Us8/0/0:3	initial	1	0%	0%	0	31	30.7
In8/0/0:12 (483 MHz)	down	2147635201	0% (0%/0%)	0%	0		0
In8/0/0:16 (507 MHz)	initial	2147631104	0% (0%/0%)	0%	0	11	37
In8/0/0:16 (507 MHz)	initial	1	0% (0%/0%)	0%	0	11	37
Us8/0/0:0	initial	2147631104	0%	0%	0	31	30.7
Us8/0/0:0	initial	1	0%	0%	0	31	30.7
Us8/0/0:1	initial	2147631104	0%	0%	0	31	30.7
Us8/0/0:1	initial	1	0%	0%	0	31	30.7
Us8/0/0:2	initial	2147631104	0%	0%	0	31	30.7
Us8/0/0:2	initial	1	0%	0%	0	31	30.7
Us8/0/0:3	initial	2147631104	0%	0%	0	31	30.7
Us8/0/0:3	initial	1	0%	0%	0	31	30.7
In8/0/0:20 (531 MHz)	down	2147635201	0% (0%/0%)	0%	0		0
In8/0/1:0 (555 MHz)	initial	2147631618	0% (0%/0%)	0%	0	12	37
Us8/0/2:0	initial	2147631618	0%	0%	0	19	30.7
Us8/0/2:1	initial	2147631618	0%	0%	0	19	30.7
Us8/0/2:2	initial	2147631618	0%	0%	0	19	30.7

## Troubleshooting Tips

**Problem** Packets are dropped when a cable modem moves from one channel to another.

**Possible Cause** When the **test cable dcc** command is used to move a cable modem from one channel to another with DCC initialization technique 3:

- If the pre-equalization coefficient is enabled, the cable modem moves and packet drop occurs for 5 seconds.
- If the pre-equalization coefficient is disabled, the cable modem moves and packet drop occurs for less than 1 second.

**Possible Cause** When the **test cable dcc** command is used to move a cable modem from one channel to another with DCC initialization technique 4:

- If the pre-equalization coefficient is enabled, the cable modem moves and packet drop occurs for less than 1 second.
- If the pre-equalization coefficient is disabled, the cable modem moves without any packet drop.

**Solution** No action is required.

## Examples

Use the **show cable load-balance target** command to display the interfaces being used for load balancing, use the **test cable load-balance** command to test whether a cable modem can move between interfaces, and use the **show cable load-balance statistics** command to display the results of the test.

The following example shows how to test whether a specific cable modem responds to both a UCC request and to an upstream channel override to move from one upstream to another in its load balancing group:

```
Router# show cable load-balance target

Target assignments:
Interface                State      Group  Target
Cable1/0/0 (669 MHz)    up        1
Cable1/0/0/U0           up        1      Cable1/0/0/U1 [enforce]
Cable1/0/0/U1           up        1
```

```
Router# show cable load-balance statistics

Statistics:

Target interface        State      Transfers
                        Complete  Pending  Retries  Failures
Cable1/0/0 (669 MHz)    up        15       0        1        0
Cable1/0/0/U0           up        33       0        1        0
Cable1/0/0/U1           up        22       0        2        0
```

```
Router# test cable load-balance 0000.394e.4e59

Sending UCC request: Cable1/0/0/U0 --> U1
Waiting for test completion .....
Test results:
  UCC Response: 0.0s
  Initial Ranging: 8.5s
  Ranging Complete: failed.
  Modem replied to DOCSIS ping.
Test summary:
  UCC Response: success rate 100% min 0.0s max 0.0s avg 0.0s
  Initial Ranging: success rate 100% min 8.5s max 8.5s avg 8.5s
Testing US Channel Override: Cable1/0/0/U1 --> U0
Waiting for test completion .....
Test results:
  Initial Ranging: 8.5s
  Ranging Complete: failed.
  Modem replied to DOCSIS ping.
Test summary:
  UCC Response: success rate 100% min 0.0s max 0.0s avg 0.0s
  Initial Ranging: success rate 100% min 8.5s max 8.5s avg 8.5s
```

```
Router# show cable load-balance statistics

Statistics:

Target interface        State      Transfers
                        Complete  Pending  Retries  Failures
Cable1/0/0 (669 MHz)    up        15       0        1        0
Cable1/0/0/U0           up        34       0        1        0
Cable1/0/0/U1           up        23       0        2        0
```

The following example shows how to test whether a specific modem responds to a UCC request to move from one upstream to another in its load balancing group:

```

Router# show cable load-balance statistics

Statistics:

Target interface      State      Transfers
                   Complete Pending  Retries  Failures
Cable1/0/0 (669 MHz) up          15         0         1         0
Cable1/0/0/U0         up          34         0         1         0
Cable1/0/0/U1         up          23         0         2         0

Router# test cable load-balance 0007.0e01.4129 ucc 1

Sending UCC request: Cable1/0/0/U0 --> U1
Waiting for test completion .....
Test results:
  UCC Response: 0.0s
  Initial Ranging: 10.3s
  Ranging Complete: 11.2s
  Modem replied to DOCSIS ping.
Test summary:
  UCC Response: success rate 100% min 0.0s max 0.0s avg 0.0s
  Initial Ranging: success rate 100% min 10.3s max 10.3s avg 10.3s
  Ranging Complete: success rate 100% min 11.2s max 11.2s avg 11.2s

```

```

Router# show cable load-balance statistics

Statistics:

Target interface      State      Transfers
                   Complete Pending  Retries  Failures
Cable1/0/0 (669 MHz) up          15         0         1         0
Cable1/0/0/U0         up          35         0         1         0
Cable1/0/0/U1         up          24         0         2         0

```

The following example shows information when moving a cable modem to a different upstream channel using DCC initialization technique 1. This example moves the cable modem 0012.17ea.f563 from interface c7/1/0 upstream 1 to interface c7/1/1 upstream 0 using DCC initialization technique 1:

```

Router# show cable modem

MAC Address      IP Address      I/F      MAC      Prim RxPwr  Timing  Num BPI
State      Sid (dB)  Offset  CPE Enb  State      Sid (dB)  Offset  CPE Enb
0012.17ea.f563 12.0.0.2      C7/1/0/U1 online    4      0.00  2449    0  N

Router# test cable dcc 0012.17ea.f563 c7/1/1 0 1

Router# show cable modem

MAC Address      IP Address      I/F      MAC      Prim RxPwr  Timing  Num BPI
State      Sid (dB)  Offset  CPE Enb  State      Sid (dB)  Offset  CPE Enb
0012.17ea.f563 12.0.0.2      C7/1/1/U0 online    3      0.00  2451    0  N

```

## Configuration Examples for Load Balancing

This section provides the following configuration examples:

## Example: Configuring Dynamic Channel Change for Load Balancing

The following examples illustrate the working of dynamic load balancing working process in DOCSIS 3.0 cable modems.

Verify configuration:

```
Router# show cable load-balance docsis-group 1
DOCSIS LB Enabled: Yes
DOCSIS 2.0 LB Enabled: No
DOCSIS 3.0 LB Enabled: Yes
DOCSIS 3.0 Static LB Enabled: No
DOCSIS 3.0 Dynamic Downstream LB Enabled: Yes
DOCSIS Status Interval DCC mask Policy Method Threshold
Group /UCC DS/US M/E/U/P/S
1 RE 60 0x38(2)/N 0 u/u 1/10/70/70/50
```

Verify channel current load:

```
Router# show cable load-balance docsis-group 1 load wideband
DOCSIS load-balancing wide band load
Interface Size Group Throughput(Kbps) /bw(Mbps) Avg-Util
Wi9/0/0:1 8 1 93324/300 36%
Wi9/0/0:2 8 1 37329/300 39%
Wi9/0/0:3 8 1 74659/300 31%
Wi9/0/0:4 8 1 0/300 13%
Wi9/0/0:5 8 1 9332/300 2%
```

Verify channel overload and target:

```
Router# show cable load-balance docsis-group 1 target wideband
Interface Bg-Id State Group Target
Wi9/0/0:1 28674 up 1 Wi9/0/0:5 ...
Wi9/0/0:2 28675 up 1 Wi9/0/0:5 ...
Wi9/0/0:3 28676 up 1 Wi9/0/0:5 ...
Wi9/0/0:4 28677 up 1 Wi9/0/0:5
Wi9/0/0:5 28678 up 1
```

Verify channel modem-list:

```
Router# show cable load-balance docsis-group 1 modem-list wideband
Codes: M - Multicast, U - UGS, P - PCMM, F - Max-Failures, X - eXcluded
L - L2vpn, R - RSVP
Primary WB MAC Address Primary DS RCC-ID Priority MUPFXLR State
Wi9/0/0:1 (10)
c8fb.26a6.c02c In9/0/0:4 1 0 ----- LB_CM_READY
c8fb.26a6.c62c In9/0/0:4 1 0 ----- LB_CM_READY
c8fb.26a6.c706 In9/0/0:4 1 0 ----- LB_CM_READY
c8fb.26a6.c0dc In9/0/0:4 1 0 ----- LB_CM_READY
c8fb.26a6.c53a In9/0/0:4 1 0 ----- LB_CM_READY
```

Verify QAM channel utilization:

```
Router# show cable load-balance docsis-group 1 rfch-util
Interface Pstate Pending-In Pending-Out Throughput(Kbps) Util
In9/0/0:4 up No No 6517 17
In9/0/0:5 NA No No 6574 17
In9/0/0:6 NA No No 6520 17
In9/0/0:7 NA No No 6738 17
In9/0/0:8 up No No 8624 22
In9/0/0:9 NA No No 8482 22
In9/0/0:10 NA No No 8353 22
```

Verify channel statistic movement:



```
Router# show cable load-balance docsis-group 1 statistics wideband
Target interface State Transfers
Complete Pending Total Failures Disabled
Wi9/0/0:1 up 0 0 0 0 0
Wi9/0/0:2 up 0 0 0 0 0
Wi9/0/0:3 up 3 0 3 0 0
Wi9/0/0:4 up 0 0 0 0 0
Wi9/0/0:5 up 9 0 9 0 0
```

The following example of the running configuration illustrates DCC for load balancing.

```
Router# show cable load all
```

```
*Nov 11 15:42:18.955: %SYS-5-CONFIG_I: Configured from console by conscable load all
Group Interval Method DCC Init Threshold
Technique Minimum Static Enforce Ugs PCMM
1 10 modems 0 5 10% --- --- ---
```

Current load:

Interface	State	Group	Utilization	Reserved	Modems	Flows	Weight
Cable3/0 (0 MHz)	initial	1	0%(0%/0%)	0%	0	0	26

Target assignments:

Interface	State	Group	Target
Cable3/0 (0 MHz)	initial	1	

Statistics:

Target interface	State	Transfers			
		Complete	Pending	Retries	Failures
Cable3/0 (0 MHz)	initial	0	0	0	0

Pending:

Modem	Group	Source interface	Target interface	Retries

The following example of the running configuration illustrates DCC for load balancing.

```
Router# show running configuration
```

```
Building configuration...
Current configuration : 11889 bytes
!
version 12.3
no service pad
service timestamps debug datetime msec
service timestamps log datetime msec
no service password-encryption
!
hostname Router
!
boot-start-marker
boot-end-marker
!
enable secret 5 $1$tEvV$8xICVVbFm10hx0hAB7DO90
enable password lab
!
no cable qos permission create
no cable qos permission update
cable qos permission modems
cable load-balance group 1 threshold load 75 enforce
cable load-balance group 1 threshold stability 75
cable load-balance group 1 policy ugs
cable load-balance group 1 threshold ugs 75
```

## Example: Configuring Dynamic Channel Change for Load Balancing

```

cable load-balance group 1 policy pcmm
cable load-balance group 1 threshold pcmm 75
no aaa new-model
ip subnet-zero
!
!
ip cef
no ip domain lookup
!
!
interface GigabitEthernet0/1
 ip address 10.14.1.130 255.255.0.0
 duplex auto
 speed auto
 media-type rj45
 no negotiation auto
!
interface GigabitEthernet0/2

```

The following example of the show cable load all command illustrates DCC for load balancing.

```
Router# show cable load all
```

```

*Nov 11 15:43:39.979: %SYS-5-CONFIG_I: Configured fromconf t
Group Interval Method DCC Init Threshold
          Technique Minimum Static Enforce Ugs PCMM
1         10      modems    0         5         75%    75%    75%    75%

Current load:

Interface          State      Group Utilization Reserved Modems Flows Weight
Cable3/0 (0 MHz)   initial    1      0%(0%/0%)  0%      0      0      26

Target assignments:

Interface          State      Group Target
Cable3/0 (0 MHz)   initial    1

Statistics:

Target interface    State      Transfers
                   Complete Pending Retries Failures
Cable3/0 (0 MHz)   initial    0         0         0         0

Pending:

Modem              Group Source interface Target interface Retries

```

The following example illustrates a DCC load balancing group with the default DCC initialization technique. This command configures load balancing group 1:

```
Router(config)# cable load-balance group 1 threshold load 10 enforce
```

This configuration creates a dynamic load balancing group with the following default settings:

```

cable load-balance group 1 method modem
cable load-balance group 1 threshold load 10 enforce
cable load-balance group 1 interval 10
cable load-balance group 1 dcc-init-technique 0

```

The following example changes this DCC load balancing configuration to initialization technique 4:

```
Router# cable load-balance group 1 dcc-init-technique 4
```



**Note** By default, UGS and PCMM policies are not turned on, so that CMs with active voice calls or PCMM calls participate in load balancing.

## Additional References

### Technical Assistance

Description	Link
<p>The Cisco Support website provides extensive online resources, including documentation and tools for troubleshooting and resolving technical issues with Cisco products and technologies.</p> <p>To receive security and technical information about your products, you can subscribe to various services, such as the Product Alert Tool (accessed from Field Notices), the Cisco Technical Services Newsletter, and Really Simple Syndication (RSS) Feeds.</p> <p>Access to most tools on the Cisco Support website requires a Cisco.com user ID and password.</p>	<p><a href="http://www.cisco.com/support">http://www.cisco.com/support</a></p>

## Feature Information for DOCSIS Load Balancing Movements

Use Cisco Feature Navigator to find information about the platform support and software image support. Cisco Feature Navigator enables you to determine which software images support a specific software release, feature set, or platform. To access Cisco Feature Navigator, go to the <https://cfng.cisco.com/> link. An account on the Cisco.com page is not required.



**Note** The following table lists the software release in which a given feature is introduced. Unless noted otherwise, subsequent releases of that software release train also support that feature.

**Table 54: Feature Information for DOCSIS Load Balancing Groups**

Feature Name	Releases	Feature Information
DOCSIS Load Balancing Movements	Cisco IOS XE Fuji 16.7.1	This feature was integrated on the Cisco cBR Series Converged Broadband Routers.





## CHAPTER 19

# DOCSIS 3.0 Downstream Bonding

The DOCSIS 3.0 Downstream Bonding feature helps cable operators offer new, more bandwidth-intensive services by adding one or more additional downstream quadrature amplitude modulation (QAM) channels to the standard broadband DOCSIS system.

Your software release may not support all the features that are documented in this module. For the latest feature information and caveats, see the release notes for your platform and software release. The Feature Information Table at the end of this document provides information about the documented features and lists the releases in which each feature is supported.

Use Cisco Feature Navigator to find information about platform support and Cisco software image support. To access Cisco Feature Navigator, go to <http://tools.cisco.com/ITDIT/CFN/>. An account on <http://www.cisco.com/> is not required.

- [Hardware Compatibility Matrix for the Cisco cBR Series Routers](#), on page 321
- [Information About DOCSIS 3.0 Downstream Bonding](#), on page 323
- [How to Configure RCP and RCC Encoding](#), on page 324
- [How to Configure Attribute Masks](#), on page 333
- [How to Enable Service Flow Priority in Downstream Extender Header](#), on page 337
- [Enabling Verbose Reporting for Receive Channel Profiles](#), on page 339
- [Configuration Example for an RCC Template](#), on page 340
- [Additional References](#), on page 341
- [Feature Information for DOCSIS 3.0 Downstream Bonding](#), on page 341

## Hardware Compatibility Matrix for the Cisco cBR Series Routers



**Note** The hardware components that are introduced in a given Cisco IOS-XE Release are supported in all subsequent releases unless otherwise specified.

Table 55: Hardware Compatibility Matrix for the Cisco cBR Series Routers

Cisco CMTS Platform	Processor Engine	Interface Cards
Cisco cBR-8 Converged Broadband Router	<p><b>Cisco IOS-XE Release 16.5.1 and Later Releases</b></p> <p>Cisco cBR-8 Supervisor:</p> <ul style="list-style-type: none"> <li>• PID—CBR-SUP-250G</li> <li>• PID—CBR-CCAP-SUP-160G</li> </ul>	<p><b>Cisco IOS-XE Release 16.5.1 and Later Releases</b></p> <p>Cisco cBR-8 CCAP Line Cards:</p> <ul style="list-style-type: none"> <li>• PID—CBR-LC-8D30-16U30</li> <li>• PID—CBR-LC-8D31-16U30</li> <li>• PID—CBR-RF-PIC</li> <li>• PID—CBR-RF-PROT-PIC</li> <li>• PID—CBR-CCAP-LC-40G</li> <li>• PID—CBR-CCAP-LC-40G-R</li> <li>• PID—CBR-CCAP-LC-G2-R</li> <li>• PID—CBR-SUP-8X10G-PIC</li> <li>• PID—CBR-2X100G-PIC</li> </ul> <p>Digital PICs:</p> <ul style="list-style-type: none"> <li>• PID—CBR-DPIC-8X10G</li> <li>• PID—CBR-DPIC-2X100G</li> </ul> <p>Cisco cBR-8 Downstream PHY Module:</p> <ul style="list-style-type: none"> <li>• PID—CBR-D31-DS-MOD</li> </ul> <p>Cisco cBR-8 Upstream PHY Modules:</p> <ul style="list-style-type: none"> <li>• PID—CBR-D31-US-MOD</li> </ul>



**Note** Do not use DPICs (8X10G and 2x100G) to forward IP traffic, as it may cause buffer exhaustion, leading to line card reload.

The only allowed traffic on a DPIC interface is DEPI, UEPI, and GCP traffic from the Cisco cBR-8 router to Remote PHY devices. Other traffic such as DHCP, SSH, and UTSC should flow via another router, since DPICs cannot be used for normal routing.

# Information About DOCSIS 3.0 Downstream Bonding

DOCSIS 3.0 Downstream Bonding enables high-speed broadband access and helps cable operators offer more bandwidth-intensive services by adding one or more additional downstream quadrature amplitude modulation (QAM) channels to the standard broadband DOCSIS system. This new set of downstream channels is grouped into one larger channel, known as a bonded channel.

Channel bonding combines several RF channels into one virtual channel. Data rates in this virtual channel range from hundreds of megabits to potentially gigabits per second, creating more available bandwidth in the network.

## Receive Channel Profile

An RCP is an encoding that represents the receive channels and receive modules of a cable modem. A cable modem communicates to the CMTS one or more RCP encodings within its registration request using either verbose description, which contains complete subtype encoding defined in DOCSIS 3.0, or simple description, which only contains RCP identifiers.

The cable modem reporting method is configurable within the MAC domain and communicated to cable modems via the MDD.

You must define an RCP-ID to describe the cable modem's capabilities for that RCP-ID and to input information about cable modems which are not defined on the system. Once configured the RCP-ID is available to the entire system since it is not meant to be card specific or mac-domain specific. The path selection module ensures that the RCP ID is accurately transmitted as part of the RCC profile.

The CableLabs MULPI specification defines standard RCPs which are automatically created by the CMTS.

## Receive Channel Configuration

A cable modem reports its ability to receive multiple channels with one or more RCP encodings in a REG-REQ or REG-REQ-MP message. Each receive channel profile describes a logical representation of the cable modem's downstream physical layer in terms of receive channels (RCs) and receive modules (RMs). The CMTS initially configures the cable modem's receive channels and receive modules with an RCC encoding in the registration response.

This feature supports any arbitrary RCP ID configuration and receive channel configuration on a Cisco cBR Series Converged Broadband Router.

## RCC Template

You can configure one or more RCC templates for an RCP. An RCC template configures the physical layer components described by an RCP, including receive modules and receive channels to specific downstream frequencies. The template also specifies the interconnections among receive modules, or between a receive module and a receive channel. An RCC template can be associated only to the cable interface (MAC domain).

A cable modem's RCP ID is matched with an RCC, when RCC templates are configured. A cable modem's RCP ID may be matched with an RCC generated by an RCC template when RCC templates are configured. The path selection module ensures that the RCP ID that is transmitted as part of the RCC profile is accurate.

At time of registration, if there are multiple valid RCCs that can be assigned to the CM after going through the sequence of checks outlined in the CableLabs MULPI specifications then the RCC with the most channels will be the one selected. If there are multiple valid RCCs of equal size then the RCC with the least amount of cable modems will be selected.

## Channel Assignment

The CMTS assigns a receive channel configuration encoding to a DOCSIS 3.0-certified cable modem operating in a Multiple Receive Channel (MRC) mode during cable modem registration.

With the implementation of this feature, the DOCSIS 3.0-certified cable modem reports its receiving capabilities and characteristics using the receive channel profile type, length, value (TLV) list in the registration request message. Based on this report, the CMTS assigns an RCC encoding that is compatible with the reported RCP.

Cable modems operating in MRC mode are assigned an RCC encoding associated with an RCP. RCC encodings may be derived from RCC templates or from a wideband-cable interface configuration.

## Downstream Traffic Forwarding

DOCSIS 3.0 introduces the concept of assigning downstream service flows of cable modems, which are operating in an MRC mode, to downstream (DS) channels or bonding groups. Forwarding interfaces assigned to service flows (SFs) can be either DS channel interfaces (integrated cable interfaces) or downstream bonding groups (wideband interfaces).



---

**Note** Valid interfaces that are available for SF assignment must be a subset of the cable modem's assigned RCC encoding.

---

## Service Flow Priority in Downstream Extended Header

The purpose of the feature is to be able to reflect the traffic priority of downstream packets into the DOCSIS extended header. The priority is derived from the service flow that the packet is mapped to. Priority refers to the service flow priority specified in the CM configuration file, or the Cisco CMTS service class configuration.

The service flow priority can be set using cable modem configuration file, or dynamic configuration.

By default, this feature is disabled on Cisco cBR-8 router, user can use **cable service flow priority** command to enable this feature.

## How to Configure RCP and RCC Encoding

The following tasks describe how to configure a receive channel profile and configuration encoding for a receive channel profile:

### Configuring the RCP ID

You must configure the RCP IDs with the cable modem capabilities that are not defined in the CMTS. This is done to supplement the standard MULPI RCP IDs already created by the CMTS.



## Before you begin

### Restrictions

The configurations are subject to RCC Templates and RCP Interactions as follows:

- RCC templates can only be created for an RCP that is already defined on the system. By default the system will contain the RCPs that are specified in the MULPI spec.
- When defining RCC templates for a particular RCP, error checking will be done to ensure that the information being configured in the RCC template does not violate the corresponding RCP information. For example, if the RCP information indicates that there are 2 receive modules then the RCC template configuration will not allow the user to configure more than 2 modules.
- Once an RCP is included in an RCC template users will not be allowed to modify the RCP. Only an RCP which is not being used by any RCC template can be modified
- A valid RCP that can be applied to an rcc-template must contain the following;
  - center-frequency-spacing
  - At least one module which defines the minimum and maximum center frequency range.
  - Rules of inheritance.
  - rcc-template inherit definition from the associated user-defined RCP, such as center-frequency-spacing.
  - rcc-template channel frequencies must fall within the range of the minimum and maximum center frequency per the corresponding RCP module.
  - common-module definition is applicable to the rcc-template module referenced with the same index.
  - rcc-template module channel frequencies overrides the same channel from the corresponding common-module.

### Procedure

	Command or Action	Purpose
Step 1	<b>enable</b> <b>Example:</b> Router> <b>enable</b>	Enables privileged EXEC mode. Enter your password if prompted.
Step 2	<b>configure terminal</b> <b>Example:</b> Router# <b>configure terminal</b>	Enters global configuration mode.
Step 3	<b>cable rcp-id rcp-id</b> <b>Example:</b> Router(config)# <b>cable rcp-id 00 10 00 01 08</b> Router(config-rcp)#	Defines the RCC template. <ul style="list-style-type: none"> <li>• <i>rcp-id</i> - Specifies an RCP ID in Hex.</li> </ul> This command changes the input mode to the RCC configuration mode.
Step 4	<b>name word</b> <b>Example:</b> Router(config-rcp)# <b>name rcp-id_1</b>	<b>name</b> —Assigns a name ro the RCP ID <ul style="list-style-type: none"> <li>• <i>word</i>—Use a string to name the RCP ID.</li> </ul> <b>Note</b> Do not include space between words in the name

	Command or Action	Purpose
Step 5	<b>center-frequency-spacing</b> <i>frequency</i> <b>Example:</b> Router (config-rcp) # <b>center-frequency-spacing 6</b>	Assigns a center frequency space to the RCP ID. The valid values are 6 and 8.
Step 6	<b>module</b> <i>module index</i> <b>minimum-center-frequency</b> <i>Hz</i> <b>maximum-center-frequency</b> <i>Hz</i> <b>Example:</b> Router (config-rcp) # <b>module 1</b> <b>minimum-center-frequency 120000000</b> <b>maximum-center-frequency 800000000</b>	Configures a receive module configuration for the selected RCP. <ul style="list-style-type: none"> <li>• <i>module index</i> - Specifies the module number for the receive module. The valid range is 1 to 12.</li> <li>• <b>minimum-center-frequency</b> - Specifies the minimum center frequency for the channels of the receive module channel.</li> <li>• <i>Hz</i> - Specifies the center frequency value in Hz. The valid range is from 111000000 to 999000000.</li> <li>• <b>maximum-center-frequency</b> - Specifies the maximum center frequency for the channels of the receive module channel.</li> </ul>
Step 7	<b>module</b> <i>module index</i> <b>number-of-adjacent-channels</b> <i>Integer</i> <b>Example:</b> Router (config-rcp) # <b>module 2</b> <b>number-of-adjacent-channels 10</b> Router (config-rcp) #	Specifies the frequency band for the receive module. The valid values are 1-255.
Step 8	<b>module</b> <i>module index</i> <b>connected-module</b> <i>module index</i> <b>Example:</b> Router (config-rcp) # <b>module 1 connected-module 0</b>	Specifies a receive channel configuration for the selected RCP. <ul style="list-style-type: none"> <li>• <b>connected-receive-module</b>— (Optional) Specifies a nested receive module in the RCC template. Generally, only one receive module is configured for an RCC template.</li> <li>• <i>module index</i>—Specifies the module number for the receive module. The valid range is 1 to 12.</li> </ul>
Step 9	<b>number-of-channels</b> <i>Number of channel</i> <b>Example:</b> Router (config-rcp) # <b>number-of-channels 8</b>	Specifies the number of receive channels in the RCP ID.
Step 10	<b>primary-capable-channels</b> <i>Number of channel</i> <b>Example:</b> Router (config-rcp) # <b>primary-capable-channels 1</b>	Specifies the number of receive channels that are defined as primary capable channels.

### What to do next

Verify RCP ID configurations using the **show cable rcps** command.

```

Router# show cable rcps
RCP ID   : 00 10 00 01 08
Name     : rcp-id 1
Center Frequency Spacing   : 6
Max number of Channels     : 8
Primary Capable Channel    : 1
Number of Modules          : 2
Module[1]:
  Number of Adjacent Channels: 10
  Minimum Center Frequency-Hz: 111000000
  Maximum Center Frequency-Hz: 999000000
Module[2]:
  Number of Adjacent Channels: 10
  Minimum Center Frequency-Hz: 120000000
  Maximum Center Frequency-Hz: 800000000

RCP ID   : 00 10 00 00 02
Name     : rcp-id 2
Center Frequency Spacing   : 6
Max number of Channels     : 2
Primary Capable Channel    : 1
Number of Modules          : 1
Module[1]:
  Number of Adjacent Channels: 10
Minimum Center Frequency-Hz: 111000000
  Maximum Center Frequency-Hz: 867000000
  Connected Module          : 64

```

## Configuring the RCC Templates

You must configure an RCC template with a unique RCP ID for a particular CMTS. A valid RCC template consists of a configured RCP ID, RMs, and RCs. There is dependency between the RCC templates and the RCP since information present in the RCP configuration is also present in RCC templates.

Each RCC encoding contains all operational DS channels with their channel parameters, including the frequency match RC attribute specified in the RCC template. An RCC template specifies the intended receive channel assignment in the available DS spectrum.



---

**Note** If an RCC template is removed from a MAC domain through configuration, the CMTS removes all RCC encodings derived from the RCC template, and all cable modems assigned to the RCC encoding are marked offline.

---

### Before you begin

At least one RC must be configured as a primary Receive Channel (RC).

## Procedure

	Command or Action	Purpose
<b>Step 1</b>	<b>enable</b> <b>Example:</b> Router> <b>enable</b>	Enables privileged EXEC mode. Enter your password if prompted.
<b>Step 2</b>	<b>configure terminal</b> <b>Example:</b> Router# <b>configure terminal</b>	Enters global configuration mode.
<b>Step 3</b>	<b>cable rcc-templates frequency-based <i>id</i></b> <b>Example:</b> Router (config) # <b>cable rcc-templates frequency-based 1</b> Router (config-rcc-freq-based) #	<i>id</i> —Specifies an RCC template. The valid range is 1-64.
<b>Step 4</b>	<b>rcp-id <i>id</i></b> <b>Example:</b> Router (config-rcc-freq-based) # <b>rcp-id 00 10 00 01 08</b>	<i>id</i> —Specifies an RCP ID for the RCC template. The valid range is 00 00 00 00 00 to FF FF FF FF. By default, the RCP ID is set to 00 00 00 00 00.
<b>Step 5</b>	<b>common-module <i>module-index</i> channel <i>group</i>list start-frequency <i>Hz</i></b> <b>Example:</b> Router (config-rcc-freq-based) # <b>common-module 1 channels 0-6 start-frequency 555000000</b>	Specifies module configurations that are common for a selected set of channels assigned to the selected RCP ID. <ul style="list-style-type: none"> <li>• <i>Module-index</i>—Specifies the index value for the receive module. The valid range is 1 to 12.</li> <li>• <b>channels</b>—Specifies the list of channels to which the common configurations apply.</li> <li>• <i>group</i>list—Specifies the list of channels to which a specific list of configurations apply. The range of values are 1-64.</li> <li>• <b>start-frequency</b> —Specifies the start frequency value in Hz.</li> <li>• <i>Hz</i>—Specifies the frequency value for the start frequency for the common module. The valid range is from 111000000 to 999000000.</li> </ul>
<b>Step 6</b>	<b>rcc-template <i>Id</i></b> <b>Example:</b> Router (config-rcc-freq-based) # <b>rcc-template 1</b>	Specifies an RCC template ID to configure the selected RCC template. <ul style="list-style-type: none"> <li>• <i>Id</i>—Specifies the ID of the RCC template. The valid range is from 1-8.</li> </ul>
<b>Step 7</b>	<b>cm-attribute-mask <i>value</i></b> <b>Example:</b>	(Optional) Configured to be used to match against the cm attribute mask define in CM 's configuration file.

	Command or Action	Purpose
	Router (config-rcc-freq-based-tmpl) # <b>cm-attribute-mask 1</b>	<ul style="list-style-type: none"> <li>• <i>value</i>—The valid range is 00 00 00 00 00 to FF FF FF FF.</li> </ul>
<b>Step 8</b>	<p><b>module</b> <i>module-index</i> <b>channel</b> <i>grouplist</i> <b>start-frequency</b> <i>Hz</i>.</p> <p><b>Example:</b></p> <pre>Router(config-rcc-freq-based) # <b>common-module 1</b> <b>channels 0-6 start-frequency 55500000</b></pre>	<p>Specifies module configurations that are common for a selected set of channels assigned to the selected RCP ID.</p> <ul style="list-style-type: none"> <li>• <i>Module-index</i>—Specifies the index value for the receive module. The valid range is 1 to 12.</li> <li>• <b>channels</b>—Specifies the list of channels to which the common configurations apply.</li> <li>• <i>grouplist</i>—Specifies the list of channels to which a specific list of configurations apply. The range of values are 1-64.</li> <li>• <b>start-frequency</b>—Specifies the start frequency value in Hz.</li> <li>• <i>Hz</i>—Specifies the frequency value for the start frequency for the common module. The valid range is from 111000000 to 999000000.</li> </ul> <p>Repeat Step 3 and Step 7 to configure other frequency based RCC templates.</p>

### What to do next

The following configuration examples show the cable rcc-template configuration:

```
cable rcc-templates frequency-based 2
  rcp-id 00 10 00 01 08
  common-module 1 channels 1-4 start-frequency 381000000
  rcc-template 1
  module 1 channels 5-8 start-frequency 501000000
  rcc-template 2
  module 1 channels 5-8 start-frequency 669000000
  rcc-template 3

cable rcc-templates frequency-based 1
  rcp-id 00 10 00 01 08
  rcc-template 1
  cm-attribute-mask 2
  module 1 channels 1-4 start-frequency 381000000
  module 2 channels 5-8 start-frequency 501000000
  rcc-template 2
  module 1 channels 1-4 start-frequency 381000000
  module 2 channels 5-8 start-frequency 669000000
  rcc-template 3
  module 1 channels 1-4 start-frequency 381000000
```

After defining an RCC template, you must assign the template to a cable interface.

## Assigning an RCC Template to a MAC Domain (Cable Interface)

The CMTS derives an RCC or RCCs from the RCC template for each MAC Domain Downstream Service Group (MD-DS-SG).

The following information is required for RCC assignment to cable modems:

- RCC templates assigned to the MAC domain.
- DS channel physical parameters including frequency and connected-receive-module index .
- DS channel primary capable indicator.
- DS channel membership to the MD-DS-SG.
- Cable modem membership to the MD-DS-SG.

This section describes how to assign an RCC template to a MAC Domain.

### Procedure

	Command or Action	Purpose
<b>Step 1</b>	<b>enable</b> <b>Example:</b> Router> <b>enable</b>	Enables privileged EXEC mode. Enter your password if prompted.
<b>Step 2</b>	<b>configure terminal</b> <b>Example:</b> Router# <b>configure terminal</b>	Enters global configuration mode.
<b>Step 3</b>	<b>interface cable slot/subslot/port</b> <b>Example:</b> Router(config)# <b>interface cable 1/0/0</b>	Enters MAC domain configuration mode. <ul style="list-style-type: none"> <li>• <i>slot</i>—Specifies the chassis slot number of the interface line card.</li> <li>• <i>subslot</i>—Specifies the secondary slot number of the interface line card. Valid subslot is 0.</li> <li>• <i>MD index</i>—Specifies the MAC Domain index number. Valid values are 0-15.</li> </ul>
<b>Step 4</b>	<b>cable rcc-template frequency-based Id</b> <b>Example:</b> Router(config-if)# <b>cable rcc-template frequency-based 1</b>	Assigns the RCC template to the specified cable interface. <ul style="list-style-type: none"> <li>• <i>Id</i>—Specifies the template you want to assign to the cable interface. The valid range is from 1 to 64.</li> </ul>

### What to do next

Verify RCC template binding to MD.

The following example shows the RCC template binding using the **show cable mac-domain rcc**

```
Router#show cable mac-domain c1/0/0 rcc
```

RCC-ID	RCP	RCs	MD-DS-SG	CMs	WB/RCC-TMPL
1	00 00 00 00 00	4	0	2	WB (Wi1/0/0:0)
2	00 00 00 00 00	4	0	2	WB (Wi1/0/0:1)
3	00 00 00 00 00	4	0	0	WB (Wi1/0/1:2)
4	00 00 00 00 00	4	0	0	WB (Wi1/0/2:3)
8	00 10 00 01 08	8	5	0	RCC-TMPL (1:1)
9	00 10 00 01 08	8	5	0	RCC-TMPL (1:2)
10	00 10 00 01 08	4	5	0	RCC-TMPL (1:3)
14	00 10 00 01 08	8	5	0	RCC-TMPL (2:1)
15	00 10 00 01 08	8	5	0	RCC-TMPL (2:2)
16	00 10 00 01 08	4	5	0	RCC-TMPL (2:3)

The following example shows the RCC template binding using the `show cable mac-domain rcc id` command.

```
Router#show cable mac-domain c1/0/0 rcc 8
```

```
RCC ID           : 8
RCP              : 00 10 00 01 08
Created Via      : rcc-template - 1:1
CM attribute mask : 0x2
Receive Channels : 8
  Receive Channel : 1
    Center Frequency : 381000000
    Primary Capability : YES
    Receive Module Conn : 1
  Receive Channel : 2
    Center Frequency : 387000000
    Primary Capability : NO
    Receive Module Conn : 1
  Receive Channel : 3
    Center Frequency : 393000000
    Primary Capability : NO
    Receive Module Conn : 1
  Receive Channel : 4
    Center Frequency : 399000000
    Primary Capability : NO
    Receive Module Conn : 1
  Receive Channel : 5
    Center Frequency : 501000000
    Primary Capability : NO
    Receive Module Conn : 2
  Receive Channel : 6
    Center Frequency : 507000000
    Primary Capability : NO
    Receive Module Conn : 2
  Receive Channel : 7
    Center Frequency : 513000000
    Primary Capability : NO
    Receive Module Conn : 2
  Receive Channel : 8
    Center Frequency : 519000000
    Primary Capability : NO
    Receive Module Conn : 2
Receive Modules : 2
  Receive Module : 1
    First Frequency : 381000000
  Receive Module : 2
    First Frequency : 501000000
```

## Assigning an RCC Template to a MAC Domain (Cable Interface)

```

Router#show cable mac-domain c9/0/2 rcc 9

RCC ID          : 9
RCP             : 00 10 00 01 08
Created Via     : rcc-template - 1:2
CM attribute mask : 0x0
Receive Channels : 8
  Receive Channel : 1
    Center Frequency : 381000000
    Primary Capability : YES
    Receive Module Conn : 1
  Receive Channel : 2
    Center Frequency : 387000000
    Primary Capability : NO
    Receive Module Conn : 1
  Receive Channel : 3
    Center Frequency : 393000000
    Primary Capability : NO
    Receive Module Conn : 1
  Receive Channel : 4
    Center Frequency : 399000000
    Primary Capability : NO
    Receive Module Conn : 1
  Receive Channel : 5
    Center Frequency : 669000000
    Primary Capability : NO
    Receive Module Conn : 2
  Receive Channel : 6
    Center Frequency : 675000000
    Primary Capability : NO
    Receive Module Conn : 2
  Receive Channel : 7
    Center Frequency : 681000000
    Primary Capability : NO
    Receive Module Conn : 2
  Receive Channel : 8
    Center Frequency : 687000000
    Primary Capability : NO
    Receive Module Conn : 2
Receive Modules : 2
  Receive Module : 1
    First Frequency : 381000000
  Receive Module : 2
    First Frequency : 669000000

```

```

Router#show cable mac-domain c1/0/0 rcc 10

RCC ID          : 10
RCP             : 00 10 00 01 08
Created Via     : rcc-template - 1:3
CM attribute mask : 0x0
Receive Channels : 4
  Receive Channel : 1
    Center Frequency : 381000000
    Primary Capability : YES
    Receive Module Conn : 2
  Receive Channel : 2
    Center Frequency : 387000000
    Primary Capability : NO
    Receive Module Conn : 2
  Receive Channel : 3
    Center Frequency : 393000000
    Primary Capability : NO
    Receive Module Conn : 2

```



```

Receive Channel      : 4
Center Frequency    : 399000000
Primary Capability   : NO
Receive Module Conn : 2
Receive Modules     : 1
Receive Module      : 2
First Frequency     : 381000000

```

## Verifying the RCC Configuration

To verify the runtime RCCs on a cable interface, use the **show cable mac-domain rcc** command.

```
Router#show cable mac-domain c1/0/0 rcc
```

RCC-ID	RCP	RCs	MD-DS-SG	CMs	WB/RCC-TMPL
1	00 00 00 00 00	4	0	2	WB (Wi1/0/0:0)
2	00 00 00 00 00	4	0	2	WB (Wi1/0/0:1)
3	00 00 00 00 00	4	0	0	WB (Wi1/0/1:2)
4	00 00 00 00 00	4	0	0	WB (Wi1/0/2:3)
8	00 10 00 01 08	8	5	0	RCC-TMPL (1:1)
9	00 10 00 01 08	8	5	0	RCC-TMPL (1:2)
10	00 10 00 01 08	4	5	0	RCC-TMPL (1:3)
14	00 10 00 01 08	8	5	0	RCC-TMPL (2:1)
15	00 10 00 01 08	8	5	0	RCC-TMPL (2:2)
16	00 10 00 01 08	4	5	0	RCC-TMPL (2:3)



---

**Note** A zero (0) value in the RCP or MD-DS-SG field indicates that the RCC encoding is configured directly through a wideband interface configuration and not through any RCC template.

---

## How to Configure Attribute Masks

DOCSIS 3.0 introduces the concept of assigning service flows to channels or bonding groups based on binary attributes. The attribute masks configured on a cable, modular, integrated or wideband interface are called provisioned attribute masks.

The two types of attributes are as follows:

- Specification-defined attributes—Contain default values based on the characteristics of the channel or bonding group.
- Operator-defined attributes—Default to zero.

The operator can configure a provisioned attribute mask for each channel and provisioned bonding group to assign values to the operator-defined binary attributes. The operator can also assign new values to override the default values of the specification-defined attributes.

The operator can configure a required attribute mask and a forbidden attribute mask for a service flow in the cable modem configuration file. These required and forbidden attribute masks are optionally provided on the DOCSIS 3.0 service flows and are matched with the provisioned attribute masks of the interfaces.

Each service flow is optionally configured with the following TLV parameters:

- Service flow required attribute mask—To configure this, assign a service flow to a channel that has a 1-bit in all positions of its provisioned attribute mask corresponding to the 1-bit in the service flow required attribute mask.
- Service flow forbidden attribute mask—To configure this, assign a service flow to a channel that has a 0-bit in all positions of its provisioned attribute mask corresponding to the 1-bit in the service flow forbidden attribute mask.

Additionally, in a cable modem-initiated dynamic service request, the cable modem can include a required attribute mask and a forbidden attribute mask for a service flow. The CMTS assigns service flows to channels or bonding groups so that all required attributes are present and no forbidden attributes are present in the cable modem configuration file.

The table below lists the supported binary attributes for channels and bonding groups.

**Table 56: Binary Attributes**

Bit Position	Definition
Bit 0	Bonded—This bit is zero for all individual channel interfaces and one for all bonding groups.
Bit 1	Low latency—This bit is set when the interface can provide relatively low latency service. This bit is set to zero for all channels, and left up to the operator to define.
Bit 2	High availability—This bit is set to zero for all channels, and left up to the operator to define.
Bit 3:15	Reserved—Set to zero.
Bit 16:31	Operator defined—Set to zero by default.

You can configure provisioned attribute masks for cable, integrated cable, wideband cable, and modular cable interfaces.

### Prerequisites

- To assign an interface to a wideband cable modem's service flow, the interface must be a subset of the cable modem's RCC.
- To assign a service flow to an integrated cable (IC) channel, the corresponding integrated cable interface must be configured and operational.

### Restrictions

- The service flow from a narrowband cable modem is always assigned to the primary interface of the cable modem. No attribute checking is performed in this case.

This section describes the following:

## Configuring Provisioned Attributes for an Integrated Cable Interface

The default provisioned attribute is zero for an integrated cable interface.

## Procedure

	Command or Action	Purpose
Step 1	<b>enable</b> <b>Example:</b> Router> <b>enable</b>	Enables privileged EXEC mode. <ul style="list-style-type: none"> <li>• Enter your password if prompted.</li> </ul>
Step 2	<b>configure terminal</b> <b>Example:</b> Router# <b>configure terminal</b>	Enters global configuration mode.
Step 3	<b>interface integrated-cable</b> { <i>slot/port</i>   <i>slot/subslot/port</i> }: <i>rf-channel</i> <b>Example:</b> Router(config)# <b>interface integrated-cable</b> 1/0/0:0	Specifies the cable interface line card on a Cisco CMTS router: <ul style="list-style-type: none"> <li>• <i>slot</i>—Chassis slot number of the cable interface line card.</li> <li>• <i>subslot</i>—subslot number of the cable interface line card. Valid subslot is always 0.</li> <li>• <i>port</i>—Downstream port number.</li> <li>• <i>rf-channel</i>—RF channel number with a range of 0 to 3.</li> </ul>
Step 4	<b>cable attribute-mask</b> <i>mask</i> <b>Example:</b> Router(config-if)# <b>cable attribute-mask</b> 800000ff	Specifies the mask for the interface.

## Configuring Provisioned Attributes for a Wideband Cable Interface

The default provisioned attribute is 0x80000000 for a wideband cable interface, and the zero bit is automatically added to the wideband cable interface whenever an attribute is configured for that interface.

## Procedure

	Command or Action	Purpose
Step 1	<b>enable</b> <b>Example:</b> Router> <b>enable</b>	Enables privileged EXEC mode. <ul style="list-style-type: none"> <li>• Enter your password if prompted.</li> </ul>
Step 2	<b>configure terminal</b> <b>Example:</b> Router# <b>configure terminal</b>	Enters global configuration mode.
Step 3	<b>interface wideband-cable</b> { <i>slot/port</i>   <i>slot/subslot/port</i> }: <i>wideband-channel</i> <b>Example:</b>	Specifies the wideband cable interface and enters interface configuration mode:

	Command or Action	Purpose
	Router(config)# <b>interface wideband-cable 1/0/1:4</b>	
<b>Step 4</b>	<b>cable downstream attribute-mask mask</b>  <b>Example:</b> Router(config-if)# <b>cable downstream attribute-mask 800000ff</b>	Specifies the mask for the interface.

## Verifying the Attribute-Based Service Flow Assignments

To verify the attribute-based assignment of service flows on a cable interface, use the **show interface cable service-flow** or **show interface wideband-cable service-flow** command as shown in the following example:

```
Router# show interface cable 3/0 service-flow
```

Sfid	Sid	Mac Address	QoS	Param	Index	Type	Dir	Curr	Active	DS-ForwIf/
			Prov	Adm	Act			State	Time	US-BG/CH
17	4	001c.ea37.9aac	3	3	3	P	US	act	13h21m	CH 3
18	N/A	001c.ea37.9aac	4	4	4	P	DS	act	13h21m	Wi3/0:0
21	6	001c.ea37.9b5a	3	3	3	P	US	act	13h21m	CH 4
22	N/A	001c.ea37.9b5a	4	4	4	P	DS	act	13h21m	Wi3/0:0
23	7	0016.925e.654c	3	3	3	P	US	act	13h21m	CH 3
24	N/A	0016.925e.654c	4	4	4	P	DS	act	13h21m	In3/0:0

```
Router# show interface wideband-cable 5/1:0 service-flow
```

Sfid	Sid	Mac Address	QoS	Param	Index	Type	Dir	Curr	Active	DS-ForwIf/
			Prov	Adm	Act			State	Time	US-BG/CH
3	8193	ffff.ffff.ffff	3	3	3	S(s)	DS	act	2h06m	Wi5/1:0

The table below shows descriptions for the fields displayed by this command:

**Table 57: show interface cable service-flow Field Descriptions**

Field	Description
Sfid	Identifies the service flow identification number.  <b>Note</b> Primary service flow IDs are displayed even for offline cable modems because they are needed for modem re-registration.
Sid	Identifies the service identification number (upstream service flows only).
Mac Address	Identifies the MAC address for the cable modem.
QoS Parameter Index Prov	Identifies the QoS parameter index for the provisioned state of this flow.
QoS Parameter Index Adm	Identifies the QoS parameter index for the Admitted state of this flow.
QoS Parameter Index Act	Identifies the QoS parameter index for the Active state of this flow.

Field	Description
Type	Indicates if the service flow is the primary flow or a secondary service flow. Secondary service flows are identified by an “S” (created statically at the time of registration, using the DOCSIS configuration file) or “D” (created dynamically by the exchange of dynamic service messages between the cable modem and CMTS).
Dir	Indicates if this service flow is DS or US.
Curr State	Indicates the current run-time state of the service flow.
Active Time	Indicates the length of time this service flow has been active.
DS-ForwIf/US-BG/CH BG/DS	Indicates the bonding group ID or the downstream RFID of the forwarding interface assigned to the downstream service flow.

## How to Enable Service Flow Priority in Downstream Extender Header

The following tasks describe how to enable service flow priority in downstream extender header:

### Enabling Service Flow Priority in Downstream Extender Header

This section describes how to enable service flow priority in downstream extender header on the Cisco cBR-8 routers:

#### Procedure

	Command or Action	Purpose
Step 1	<b>enable</b> <b>Example:</b> Router> <b>enable</b>	Enables privileged EXEC mode. <ul style="list-style-type: none"><li>• Enter your password if prompted.</li></ul>
Step 2	<b>configure terminal</b> <b>Example:</b> Router# <b>configure terminal</b>	Enters global configuration mode.
Step 3	<b>cable service flow priority</b> <b>Example:</b> Router(config)# <b>cable service flow priority</b>	Enables the service flow priority in downstream extender header.

## Verifying the Enablement of the Service Flow Priority in Downstream Extended Header

To verify the enablement of the service flow priority in downstream extended header, use the **show running-config | in service flow** or **show cable modem [ip-address | mac-address] verbose** command as shown in the following example:

```
Router# show running-config | in service flow
cable service flow priority

Router# show cable modem 100.1.2.110 verbose

MAC Address                : 0025.2e2d.74f8
IP Address                  : 100.1.2.110
IPv6 Address                : 2001:420:3800:909:7964:98F3:7760:ED2
Dual IP                     : Y
Prim Sid                    : 1
Host Interface              : C3/0/0/U0
MD-DS-SG / MD-US-SG        : N/A / N/A
MD-CM-SG                    : 0x900000
Primary Downstream          : In3/0/0:32 (RfId : 12320, SC-QAM)
Wideband Capable           : Y
DS Tuner Capability         : 8
RCP Index                   : 6
RCP ID                      : 00 00 00 00 00
Downstream Channel DCID RF Channel : 191 3/0/0:32 (SC-QAM)
UDC Enabled                 : N
US Frequency Range Capability : Standard (5-42 MHz)
Extended Upstream Transmit Power : 0dB
Multi-Transmit Channel Mode : N
Upstream Channel            : US0
Ranging Status              : sta
Upstream SNR (dB)           : 39.8
Upstream Data SNR (dB)      : 36.12
Received Power (dBmV)       : -1.00
Timing Offset                (97.6 ns) : 1799
Initial Timing Offset       : 1799
Rng Timing Adj Moving Avg(0.381 ns) : 0
Rng Timing Adj Lt Moving Avg : 0
Rng Timing Adj Minimum      : 0
Rng Timing Adj Maximum      : 0
Pre-EQ Good                  : 0
Pre-EQ Scaled                : 0
Pre-EQ Impulse               : 0
Pre-EQ Direct Loads         : 0
Good Codewords rx           : 8468
Corrected Codewords rx      : 0
Uncorrectable Codewords rx  : 0
Phy Operating Mode           : atdma
sysDescr                     :
Downstream Power             : 0.00 dBmV (SNR = ----- dB)
MAC Version                  : DOC3.0
QoS Provisioned Mode         : DOC1.1
Enable DOCSIS2.0 Mode        : Y
Service Flow Priority         : N
Modem Status                  : {Modem= online, Security=disabled}
Capabilities                  : {Frag=Y, Concat=Y, PHS=Y}
Security Capabilities         : {Priv=, EAE=N, Key_len=}
L2VPN Capabilities           : {L2VPN=N, eSAFE=N}
L2VPN type                    : {CLI=N, DOCSIS=N}
Sid/Said Limit                : {Max US Sids=16, Max DS Sids=15}
```

```

Optional Filtering Support      : {802.1P=N, 802.1Q=N, DUT=N}
Transmit Equalizer Support     : {Taps/Symbol= 1, Num of Taps= 24}
CM Capability Reject           : {15,22,23,24,25,26,27,28,29,35,36,38}
Flaps                          : 3(Oct 8 16:22:23)
Errors                         : 0 CRCs, 0 HCSes
Stn Mtn Failures              : 0 aborts, 2 exhausted
Total US Flows                 : 1(1 active)
Total DS Flows                 : 1(1 active)
Total US Data                  : 294 packets, 25903 bytes
Total US Throughput            : 143 bits/sec, 0 packets/sec
Total DS Data                  : 91 packets, 10374 bytes
Total DS Throughput            : 0 bits/sec, 0 packets/sec
LB group ID assigned           : 1
LB group ID in config file     : N/A
LB policy ID                   : 0
LB policy ID in config file    : 0
LB priority                    : 0
Tag                            : d30
Required DS Attribute Mask     : 0x0
Forbidden DS Attribute Mask    : 0x0
Required US Attribute Mask     : 0x0
Forbidden US Attribute Mask    : 0x0
Service Type ID                :
Service Type ID in config file :
Active Classifiers              : 0 (Max = NO LIMIT)
CM Upstream Filter Group       : 0
CM Downstream Filter Group     : 0
CPE Upstream Filter Group      : 0
CPE Downstream Filter Group    : 0
DSA/DSX messages              : permit all
Voice Enabled                   : NO
DS Change Times                : 0
Boolean Services               : 0
CM Energy Management Capable   : N
CM Enable Energy Management    : N
CM Enter Energy Management     : NO
Battery Mode                   : N
Battery Mode Status            :
Number of Multicast DSIDs Support : 16
MDF Capability Mode            : 2
IGMP/MLD Version               : MLDv2
FCType10 Forwarding Support    : Y
Features Bitmask               : 0x0
Total Time Online              : 6h00m (6h00m since last counter reset)
CM Initialization Reason       : POWER_ON

```

## Enabling Verbose Reporting for Receive Channel Profiles

A receive channel profile is an encoding that represents the receive channels and receive modules of a cable modem. A cable modem communicates to the CMTS one or more RCP encodings within its registration request using either verbose description, which contains complete subtype encodings defined in DOCSIS 3.0, or simple description, which only contains RCP identifiers.

### Procedure

	Command or Action	Purpose
Step 1	enable  Example:	Enables privileged EXEC mode.  • Enter your password if prompted.

	Command or Action	Purpose
	Router> <b>enable</b>	
<b>Step 2</b>	<b>configure terminal</b>  <b>Example:</b> Router# <b>configure terminal</b>	Enters global configuration mode.
<b>Step 3</b>	<b>interface cable</b> { <i>slot/port</i>   <i>slot/subslot/port</i> }  <b>Example:</b> Router(config)# <b>interface cable7/0/0</b>	Specifies the cable interface line card on a Cisco CMTS router: <ul style="list-style-type: none"> <li>• <i>slot</i>—Chassis slot number of the cable interface line card.</li> <li>• <i>subslot</i>—subslot number of the cable interface line card. Valid subslot is 0.</li> <li>• <i>port</i>—Downstream port number.</li> </ul>
<b>Step 4</b>	<b>cable rcp-control verbose</b>  <b>Example:</b> Router(config-if)# <b>cable rcp-control verbose</b>	Enables RCP reporting with verbose description.

## Configuration Example for an RCC Template

The following sample shows an RCP ID configuration:

```
...
!
cable rcp-id 00 10 00 01 08
  center-frequency-spacing 6
  module 1 minimum-center-frequency 120000000 maximum-center-frequency 800000000 module 1
  number-of-adjacent-channels 10
  module 2 minimum-center-frequency 120000000 maximum-center-frequency 800000000 module 2
  number-of-adjacent-channels 10
  number-of-channels 8
  primary-capable-channels 1
!
```

The following sample shows an RCC template configuration:

```
...
!
cable rcc-templates frequency-based 1
  rcp-id 00 10 00 01 08
  rcc-template 1
  cm-attribute-mask 2
  module 1 channels 1-4 start-frequency 381000000
  module 2 channels 5-8 start-frequency 501000000
  rcc-template 2
  module 1 channels 1-4 start-frequency 381000000
  module 2 channels 5-8 start-frequency 669000000
  rcc-template 3
  module 1 channels 1-4 start-frequency 381000000
```



!

The following sample shows an RCC template configuration using the **common-module** option:

```
...
!
cable rcc-templates frequency-based 2
  rcp-id 00 10 00 01 08
  common-module 1 channels 1-4 start-frequency 381000000
  rcc-template 1
  module 1 channels 5-8 start-frequency 501000000
  rcc-template 2
  module 1 channels 5-8 start-frequency 669000000
  rcc-template 3
!
```

The following sample shows the assignment of an RCC template to MAC Domain:

```
...
!
configure terminal
interface c1/0/0
  cable rcc-templates frequency-based 1
end
...
```

## Additional References

### Technical Assistance

Description	Link
<p>The Cisco Support website provides extensive online resources, including documentation and tools for troubleshooting and resolving technical issues with Cisco products and technologies.</p> <p>To receive security and technical information about your products, you can subscribe to various services, such as the Product Alert Tool (accessed from Field Notices), the Cisco Technical Services Newsletter, and Really Simple Syndication (RSS) Feeds.</p> <p>Access to most tools on the Cisco Support website requires a Cisco.com user ID and password.</p>	<a href="http://www.cisco.com/support">http://www.cisco.com/support</a>

## Feature Information for DOCSIS 3.0 Downstream Bonding

Use Cisco Feature Navigator to find information about the platform support and software image support. Cisco Feature Navigator enables you to determine which software images support a specific software release, feature set, or platform. To access Cisco Feature Navigator, go to the <https://cfng.cisco.com/> link. An account on the Cisco.com page is not required.



**Note** The following table lists the software release in which a given feature is introduced. Unless noted otherwise, subsequent releases of that software release train also support that feature.

**Table 58: Feature Information for Downstream Interface Configuration**

Feature Name	Releases	Feature Information
DOCSIS 3.0 Downstream Bonding	Cisco IOS XE Everest 16.6.1	This feature was integrated on the Cisco cBR Series Converged Broadband Router.
Service Flow Priority in Downstream Extended Header	Cisco IOS XE Everest 16.6.1	This feature was integrated on the Cisco cBR Series Converged Broadband Router.



## CHAPTER 20

# DOCSIS 2.0 A-TDMA Modulation Profiles

This document describes the DOCSIS 2.0 A-TDMA services feature, which provides support for DOCSIS 2.1 Advanced Time Division Multiple Access (A-TDMA) upstream modulation profiles on the router. This feature supplements the existing support for DOCSIS 1.0 and DOCSIS 1.1 Time Division Multiple Access (TDMA) modulation profiles.

Your software release may not support all the features that are documented in this module. For the latest feature information and caveats, see the release notes for your platform and software release. The Feature Information Table at the end of this document provides information about the documented features and lists the releases in which each feature is supported.

Use Cisco Feature Navigator to find information about platform support and Cisco software image support. To access Cisco Feature Navigator, go to <http://tools.cisco.com/ITDIT/CFN/>. An account on <http://www.cisco.com/> is not required.

### Contents

- [Hardware Compatibility Matrix for the Cisco cBR Series Routers, on page 343](#)
- [Prerequisites for DOCSIS 2.0 A-TDMA Modulation Profiles, on page 345](#)
- [Restrictions for DOCSIS 2.0 A-TDMA Services, on page 345](#)
- [Information About DOCSIS 2.0 A-TDMA Services, on page 345](#)
- [How to Configure DOCSIS 2.0 A-TDMA Services, on page 348](#)
- [Monitoring the DOCSIS 2.0 A-TDMA Services, on page 352](#)
- [Configuration Examples for DOCSIS 2.0 A-TDMA services, on page 355](#)
- [Additional References, on page 358](#)
- [Feature Information for DOCSIS 2.0 A-TDMA Modulation Profile, on page 359](#)

## Hardware Compatibility Matrix for the Cisco cBR Series Routers



---

**Note** The hardware components that are introduced in a given Cisco IOS-XE Release are supported in all subsequent releases unless otherwise specified.

---

Table 59: Hardware Compatibility Matrix for the Cisco cBR Series Routers

Cisco CMTS Platform	Processor Engine	Interface Cards
Cisco cBR-8 Converged Broadband Router	<p><b>Cisco IOS-XE Release 16.5.1 and Later Releases</b></p> <p>Cisco cBR-8 Supervisor:</p> <ul style="list-style-type: none"> <li>• PID—CBR-SUP-250G</li> <li>• PID—CBR-CCAP-SUP-160G</li> </ul>	<p><b>Cisco IOS-XE Release 16.5.1 and Later Releases</b></p> <p>Cisco cBR-8 CCAP Line Cards:</p> <ul style="list-style-type: none"> <li>• PID—CBR-LC-8D30-16U30</li> <li>• PID—CBR-LC-8D31-16U30</li> <li>• PID—CBR-RF-PIC</li> <li>• PID—CBR-RF-PROT-PIC</li> <li>• PID—CBR-CCAP-LC-40G</li> <li>• PID—CBR-CCAP-LC-40G-R</li> <li>• PID—CBR-CCAP-LC-G2-R</li> <li>• PID—CBR-SUP-8X10G-PIC</li> <li>• PID—CBR-2X100G-PIC</li> </ul> <p>Digital PICs:</p> <ul style="list-style-type: none"> <li>• PID—CBR-DPIC-8X10G</li> <li>• PID—CBR-DPIC-2X100G</li> </ul> <p>Cisco cBR-8 Downstream PHY Module:</p> <ul style="list-style-type: none"> <li>• PID—CBR-D31-DS-MOD</li> </ul> <p>Cisco cBR-8 Upstream PHY Modules:</p> <ul style="list-style-type: none"> <li>• PID—CBR-D31-US-MOD</li> </ul>



**Note** Do not use DPICs (8X10G and 2x100G) to forward IP traffic, as it may cause buffer exhaustion, leading to line card reload.

The only allowed traffic on a DPIC interface is DEPI, UEPI, and GCP traffic from the Cisco cBR-8 router to Remote PHY devices. Other traffic such as DHCP, SSH, and UTSC should flow via another router, since DPICs cannot be used for normal routing.

## Prerequisites for DOCSIS 2.0 A-TDMA Modulation Profiles

- The cable physical plant must be capable of supporting the higher-bandwidth DOCSIS 2.0 A-TDMA modulation profiles.
- Cable modems must be DOCSIS-compliant. If cable modems go offline, or appear to be online but do not pass traffic when in the mixed TDMA/A-TDMA mode, upgrade the modem software to a DOCSIS-compliant version.
- The following are required to support the DOCSIS 2.0 A-TDMA features:
  - Cable modems must be DOCSIS 2.0 capable.
  - The DOCSIS configuration file for a DOCSIS 2.0 cable modem must either omit the DOCSIS 2.0 Enable field (TLV 39), or it must set TLV 39 to 1 (enable). If you set TLV 39 to 0 (disable), a DOCSIS 2.0 CM uses the TDMA mode.
  - The upstream must be configured for either A-TDMA-only or mixed TDMA/A-TDMA mode. To use the 6.4 MHz channel width, the upstream must be configured for A-TDMA-only mode.
- Complete a basic configuration of the router; this includes, at a minimum, the following tasks:
  - Configure a host name and password for the router.
  - Configure the router to support Internet Protocol (IP) operations.
  - Install and configure at least one WAN adapter to provide backbone connectivity.
- Determine a channel plan for the router and all of its cable interfaces.
- Verify that your headend site includes all necessary servers to support DOCSIS and Internet connectivity, including DHCP, ToD, and TFTP servers.
- The system clock on the router should be set to a current date and time to ensure that system logs have the proper timestamp and to ensure that the BPI+ subsystem uses the correct timestamp for verifying cable modem digital certificates.

## Restrictions for DOCSIS 2.0 A-TDMA Services

- Does not support virtual channels, as described in DOCSIS 2.0 specification.
- Does not support Synchronous Code Division Multiple Access (S-CDMA) channels.
- Changing the DOCSIS mode of an upstream takes all cable modems on that upstream offline, which forces the cable modems to reregister, so that the CMTS can determine the capabilities of the cable modems on the new channels.

## Information About DOCSIS 2.0 A-TDMA Services

DOCSIS 2.0 A-TDMA services improve the maximum upstream bandwidth on existing DOCSIS 1.0 and DOCSIS 1.1 cable networks by providing a number of advanced PHY capabilities that have been specified by the new DOCSIS 2.0 specifications.

DOCSIS 2.0 A-TDMA services incorporate the following advantages and improvements of DOCSIS 2.0 networks:

- Builds on existing DOCSIS cable networks by providing full compatibility with existing DOCSIS 1.0 and DOCSIS 1.1 cable modems. (The registration response (REG-RSP) message contains the DOCSIS version number to identify each cable modem's capabilities.)
- Upstreams can be configured for three different modes to support different mixes of cable modems:
  - An upstream can be configured for TDMA mode to support only DOCSIS 1.0 and DOCSIS 1.1 cable modems.
  - An upstream can be configured for A-TDMA mode to support only DOCSIS 2.0 cable modems.
  - An upstream can be configured for a mixed, TDMA/A-TDMA mode, to support both DOCSIS 1.0/DOCSIS 1.1 and DOCSIS 2.0 cable modems on the same upstream.



---

**Note** DOCSIS 2.0 A-TDMA cable modems will not register on a TDMA upstream if an A-TDMA or mixed upstream exists in the same MAC domain, unless the CMTS explicitly switches the cable modem to another upstream using an Upstream Channel Change (UCC) message. DOCSIS 1.0 and DOCSIS 1.1 cable modems cannot register on an A-TDMA-only upstream.

---

- A-TDMA mode defines new interval usage codes (IUC) of A-TDMA short data grants, long data grants, and Unsolicited Grant Service (UGS) grants (IUC 9, 10, and 11) to supplement the existing DOCSIS 1.1 IUC types.
- Increases the maximum channel capacity for A-TDMA upstreams to 30 Mbps per 6 MHz channel.
- A-TDMA and mixed modes of operation provide higher bandwidth on the upstream using new 32-QAM and 64-QAM modulation profiles, while retaining support for existing 16-QAM and QPSK modulation profiles. In addition, an 8-QAM modulation profile is supported for special applications.
- Supports a minislot size of 1 tick for A-TDMA operations.
- Increases channel widths to 6.4 MHz (5.12 Msymbol rate) for A-TDMA operations.
- A-TDMA and mixed modes of operation provide a more robust operating environment with increased protection against ingress noise and other signal impairments, using a number of new features:
  - Uses a symbol (T)-spaced adaptive equalizer structure to increase the equalizer tap size to 24 taps, compared to 8 taps in DOCSIS 1.x mode. This allows operation in the presence of more severe multipath and microreflections, and can accommodate operation near band edges where group delay could be a problem.
  - Supports new QPSK0 and QPSK1 preambles, which provide improved burst acquisition by performing simultaneous acquisition of carrier and timing lock, power estimates, equalizer training, and constellation phase lock. This allows shorter preambles, reducing implementation loss.
  - Increases the forward error correction (FEC) T-byte size to 16 bytes per Reed Solomon block (T=16) with programmable interleaving.

## Modes of Operation

Depending on the configuration, the DOCSIS 2.0 A-TDMA Service feature supports either DOCSIS or Euro-DOCSIS operation:

- DOCSIS cable networks are based on the ITU J.83 Annex B physical layer standard and Data-over-Cable Service Interface Specifications (DOCSIS, Annex B) specification, which use 6 MHz National Television Systems Committee (NTSC) channel plans. In this mode, the downstream uses a 6 MHz channel width

in the 85 to 860 MHz frequency range, and the upstream supports multiple channel widths in the 5 to 42 MHz frequency range.

- EuroDOCSIS cable networks are based on the ITU J.112 Annex A physical layer standard and European DOCSIS (EuroDOCSIS, Annex A) specification, which use 8 MHz Phase Alternating Line (PAL) and Systeme Electronique Couleur Avec Memoire (SECAM) channel plans. In this mode, the downstream uses an 8 MHz channel width in the 85 to 860 MHz frequency range, and the upstream supports multiple channel widths in the 5 to 65 MHz frequency range.



**Note** The difference between DOCSIS and EuroDOCSIS is at the physical layer. To support a DOCSIS or EuroDOCSIS network requires the correct configuration of the DOCSIS 2.0 A-TDMA Service card, as well as upconverters, diplex filters, and other equipment that supports the network type.

The table below shows the maximum supported DOCSIS 1.1 data rates.

**Table 60: Maximum DOCSIS 1.1 Data Rates**

Upstream Channel Width	Modulation Scheme	Baud Rate Sym/sec	Maximum Raw Bit Rate Mbit/sec
3.2 MHz	16-QAM QPSK	2.56 M	10.24 5.12
1.6 MHz	16-QAM QPSK	1.28 M	5.12 2.56

The table below shows the maximum supported DOCSIS 2.0 (A-TDMA-mode) data rates.

**Table 61: Maximum DOCSIS 2.0 (A-TDMA-mode) Data Rates**

Upstream Channel Width	Modulation Scheme	Baud Rate Sym/sec	Maximum Raw Bit Rate Mbit/sec
6.4 MHz	64-QAM	5.12 M	30.72
	32-QAM		25.60
	16-QAM		20.48
	8-QAM		15.36
	QPSK		10.24
3.2 MHz	64-QAM	2.56 M	15.36
	32-QAM		12.80
	16-QAM		10.24
	8-QAM		7.68
	QPSK		5.12

Upstream Channel Width	Modulation Scheme	Baud Rate Sym/sec	Maximum Raw Bit Rate Mbit/sec
1.6 MHz	64-QAM	1.28 M	7.68
	32-QAM		6.40
	16-QAM		5.12
	8-QAM		3.84
	QPSK		2.56

## Modulation Profiles

To simplify the administration of A-TDMA and mixed TDMA/A-TDMA modulation profiles, the DOCSIS 2.0 A-TDMA Service feature provides a number of preconfigured modulation profiles that are optimized for different modulation schemes. We recommend using these preconfigured profiles.

Each mode of operation also defines a default modulation profile that is automatically used when a profile is not specifically assigned to an upstream. The default modulation profiles cannot be deleted. The table below lists the valid ranges according to cable interface and modulation type:

**Table 62: Allowable Ranges for Modulation Profiles**

Cable Interface	DOCSIS 1.X (TDMA)	Mixed DOCSIS 1.X/2.0	DOCSIS 2.0 (A-TDMA)
Cisco cBR-8 CCAP Line Cards	1 to 400 (default is 21)	1 to 400 (default 121)	1 to 400 (default 221)

## Benefits

The DOCSIS 2.0 A-TDMA Service feature provides the following benefits to cable service providers and their partners and customers:

- Full compatibility with DOCSIS 1.0 and DOCSIS 1.1 cable modems (CMs) and cable modem termination systems (CMTS).
- Additional channel capacity in the form of more digital bits of throughput capacity in the upstream path.
- Increased protection against electronic impairments that occur in cable systems, allowing for a more robust operating environment.

## How to Configure DOCSIS 2.0 A-TDMA Services

This section contains the following:

### Creating Modulation Profiles

Cisco cable modem termination systems (CMTSs) can handle modulation profiles for the RF configuration of a voice and data cable modem plant. Cisco IOS® Software is designed with a default modulation profile that is optimal in most conditions. Therefore, do not change the default configuration. However, if the modulation needs are different for the customer plant, Cisco IOS Software has the ability to customize and to configure the modulation profiles to suit the customer needs.





**Caution** Only an expert, who understands modulation changes and Data-over-Cable Service Interface Specifications (DOCSIS), should modify these parameters. Otherwise, changes can cause disruption or the degradation of services because the commands affect the physical layer.

This section describes how to create modulation profiles for the different modes of DOCSIS operations, using the preconfigured modulation profile options.

## Creating a TDMA Modulation Profile

This section describes how to create a modulation profile for the DOCSIS 1.0/DOCSIS 1.1 TDMA mode of operation, using one of the preconfigured modulation profiles.

### Procedure

	Command or Action	Purpose
Step 1	<b>enable</b> <b>Example:</b> Router> <b>enable</b>	Enables privileged EXEC mode. Enter your password if prompted.
Step 2	<b>configure terminal</b> <b>Example:</b> Router# <b>configure terminal</b>	Enters global configuration mode.
Step 3	<b>cable modulation-profile</b> <i>profile</i> <b>tdma</b> { <b>mix</b>   <b>qam-16</b>   <b>qpsk</b>   <b>robust-mix</b> } <b>Example:</b> Router(config)# <b>cable modulation-profile 3 tdma mix</b> Router(config)# <b>cable modulation-profile 4 tdma qpsk</b>	Creates a preconfigured modulation profile, where the burst parameters are set to their default values for each burst type: <b>Note</b> You can also create custom modulation profiles with the <b>cable modulation-profile</b> command by configuring the values for the individual burst parameters. These parameters, however, should not be modified unless you are thoroughly familiar with how changing each parameter affects the DOCSIS MAC layer. We recommend using the preconfigured default modulation profiles for most cable plants.
Step 4	<b>exit</b> <b>Example:</b> Router(config)# <b>exit</b>	Exits global configuration mode.

## Creating a Mixed Mode Modulation Profile

This section describes how to create a modulation profile for the mixed TDMA/A-TDMA mode of operation, using one of the preconfigured modulation profiles.

## Procedure

	Command or Action	Purpose
<b>Step 1</b>	<b>enable</b> <b>Example:</b> Router> <b>enable</b>	Enables privileged EXEC mode. Enter your password if prompted.
<b>Step 2</b>	<b>configure terminal</b> <b>Example:</b> Router# <b>configure terminal</b>	Enters global configuration mode.
<b>Step 3</b>	<b>cable modulation-profile</b> <i>profile</i> <b>mixed</b> { <b>mix-high</b>   <b>mix-low</b>   <b>mix-mid</b>   <b>mix-qam</b>   <b>qam-16</b>   <b>qpsk</b>   <b>robust-mix-high</b>   <b>robust-mix-mid</b>   <b>robust-mix-qam</b> } <b>Example:</b> Router(config)# <b>cable modulation-profile</b> 143 <b>mixed</b> <b>mix-medium</b> Router(config)# <b>cable modulation-profile</b> 144 <b>mixed</b> <b>mix-high</b>	Creates a preconfigured modulation profile, where the burst parameters are set to their default values for each burst type: <b>Note</b> The <b>robust-mix</b> profiles are similar to but more robust than the <b>mix</b> profiles, so that they are more able to deal with noise on the upstream. <b>Note</b> You can also create custom modulation profiles with the <b>cable modulation-profile</b> command by configuring the values for the individual burst parameters. These parameters, however, should not be modified unless you are thoroughly familiar with how changing each parameter affects the DOCSIS MAC layer. We recommend using the preconfigured default modulation profiles for most cable plants.
<b>Step 4</b>	<b>exit</b> <b>Example:</b> Router(config)# <b>exit</b>	Exits global configuration mode.

## Creating an A-TDMA Modulation Profile

This section describes how to create a modulation profile for the DOCSIS 2.0 A-TDMA mode of operation, using one of the preconfigured modulation profiles.

## Procedure

	Command or Action	Purpose
<b>Step 1</b>	<b>enable</b> <b>Example:</b> Router> <b>enable</b>	Enables privileged EXEC mode. Enter your password if prompted.
<b>Step 2</b>	<b>configure terminal</b> <b>Example:</b> Router# <b>configure terminal</b>	Enters global configuration mode.

	Command or Action	Purpose
Step 3	<p><b>cable modulation-profile</b> <i>profile</i> <i>atdma</i> {<b>mix-high</b>   <b>mix-low</b>   <b>mix-mid</b>   <b>mix-qam</b>   <b>qam-8</b>   <b>qam-16</b>   <b>qam-32</b>   <b>qam-64</b>   <b>qpsk</b>   <b>robust-mix-high</b>   <b>robust-mix-low</b>   <b>robust-mix-mid</b>}</p> <p><b>Example:</b></p> <pre>Router(config)# cable modulation-profile 242 atdma qam-32 Router(config)# cable modulation-profile 243 atdma qam-64</pre> <p><b>Example:</b></p> <pre>cable modulation-profile 45 tdma request 0 16 0 22 qpsk scrambler 152 no-diff 64 fixed cable modulation-profile 45 tdma initial 5 34 0 48 16qam scrambler 152 no-diff 256 fixed cable modulation-profile 45 tdma station 5 34 0 48 16qam scrambler 152 no-diff 256 fixed cable modulation-profile 45 tdma short 3 76 12 22 16qam scrambler 152 no-diff 128 shortened cable modulation-profile 45 tdma long 9 232 0 22 16qam scrambler 152 no-diff 128 shortened  cable modulation-profile 45 tdma initial 5 34 0 48 16qam scrambler 152 no-diff 256 fixed</pre>	<p><b>Note</b> For Cisco Remote PHY 220, preamble with QPSK modulation must have values—<math>32 \times 2^n</math> (0, 1, 2, 3) bits.</p> <p>Preamble with 16-QAM modulation must have values—<math>64 \times 2^n</math> (0, 1, 2,) bits.</p> <p><b>Note</b> The <b>robust-mix</b> profiles are similar to but more robust than the <b>mix</b> profiles, so that they are more able to deal with noise on the upstream.</p> <p><b>Note</b> You can also create custom modulation profiles with the <b>cable modulation-profile</b> command by configuring the values for the individual burst parameters. These parameters, however, should not be modified unless you are thoroughly familiar with how changing each parameter affects the DOCSIS MAC layer. We recommend using the preconfigured default modulation profiles for most cable plants.</p> <p><b>Note</b> For Cisco Remote PHY 220, preamble with QPSK modulation must have values—<math>32 \times 2^n</math> (0, 1, 2, 3) bits.</p> <p>Preamble with 16-QAM modulation must have values—<math>64 \times 2^n</math> (0, 1, 2,) bits.</p>
Step 4	<p><b>exit</b></p> <p><b>Example:</b></p> <pre>Router(config)# exit</pre>	Exits global configuration mode.

## Configuring the DOCSIS Mode and Profile on an Upstream

This section describes how to configure an upstream for a DOCSIS mode of operation, and then to assign a particular modulation profile to that upstream.



**Note** By default, all upstreams are configured for ATDMA-only mode, using the default modulation profile.

### Procedure

	Command or Action	Purpose
Step 1	<p><b>enable</b></p> <p><b>Example:</b></p> <pre>Router&gt; enable</pre>	Enables privileged EXEC mode. Enter your password if prompted.

	Command or Action	Purpose
Step 2	<b>configure terminal</b> <b>Example:</b> Router# <code>configure terminal</code>	Enters global configuration mode.
Step 3	<b>controller upstream-Cable slot/subslot/port</b> <b>Example:</b> Router(config)# <code>controller upstream-Cable 2/0/1</code>	Enters controller configuration mode for the interface.
Step 4	<b>us-channel n docsis-mode {atdma   tdma   tdma-atdma}</b> <b>Example:</b> Router(config-controller)# <code>us-channel 0 docsis-mode atdma</code>	Configures the upstream for the desired DOCSIS mode of operation.
Step 5	<b>us-channel n modulation-profile primary-profile-number [secondary-profile-number] [tertiary-profile-number]</b> <b>Example:</b> Router(config-controller)# <code>us-channel 0 modulation-profile 241</code>	Assigns up to three modulation profiles to the upstream port. <b>Note</b> The type of modulation profiles must match the DOCSIS mode configured for the upstream, using the <b>us-channel docsis-mode</b> command.
Step 6	<b>us-channel n equalization-coefficient</b> <b>Example:</b> Router(config-controller)# <code>us-channel 0 equalization-coefficient</code>	(Optional) Enables the use of a DOCSIS pre-equalization coefficient on the upstream port.
Step 7	<b>us-channel n ingress-noise-cancellation interval</b> <b>Example:</b> Router(config-controller)# <code>us-channel 0 ingress-noise-cancellation 400</code>	(Optional) Configures the interval, in milliseconds, for which the interface card should sample the signal on an upstream to correct any ingress noise that has appeared on that upstream.
Step 8	<b>us-channel n maintain-psd</b> <b>Example:</b> Router(config-controller)# <code>us-channel 0 maintain-psd</code>	(Optional) Requires DOCSIS 2.0 cable modems that are operating on an ATDMA-only upstream to maintain a constant power spectral density (PSD) after a modulation rate change. <b>Note</b> Repeat <a href="#">Step 3, on page 352</a> through <a href="#">Step 8, on page 352</a> for each upstream to be configured.
Step 9	<b>end</b> <b>Example:</b> Router(config-controller)# <code>end</code>	Exits controller configuration mode and returns to privileged EXEC mode.

## Monitoring the DOCSIS 2.0 A-TDMA Services

This section contains the following:

## Displaying Modulation Profiles

To display the modulation profiles that are currently defined on the CMTS, use the **show cable modulation-profile** command without any options:

```
Router# show cable modulation-profile
```

Mod	Docsis	IUC	Type	Pre len	Diff enco	FEC T	FEC k	Scramb seed	Max B	Guard time	Last CW	Scramb size	Pre offst	Pre Type	RS
	-Mode						BYTE	BYTE	siz	size	short				
1	atdma	request	16qam	32	no	0x0	0x10	0x152	0	22	no	yes	0	qpsk1	no
1	atdma	initial	16qam	64	no	0x5	0x22	0x152	0	48	no	yes	0	qpsk1	no
1	atdma	station	16qam	64	no	0x5	0x22	0x152	0	48	no	yes	0	qpsk1	no
1	atdma	a-short	16qam	64	no	0x4	0x4C	0x152	7	22	yes	yes	0	qpsk1	no
1	atdma	a-long	16qam	64	no	0x9	0xE8	0x152	0	22	yes	yes	0	qpsk1	no
1	atdma	a-ugs	16qam	64	no	0x9	0xE8	0x152	0	22	yes	yes	0	qpsk1	no
2	atdma	request	16qam	32	no	0x0	0x10	0x152	0	22	no	yes	0	qpsk1	no
2	atdma	initial	16qam	64	no	0x5	0x22	0x152	0	48	no	yes	0	qpsk1	no
2	atdma	station	16qam	64	no	0x5	0x22	0x152	0	48	no	yes	0	qpsk1	no
2	atdma	a-short	16qam	64	no	0x4	0x4C	0x152	7	22	yes	yes	0	qpsk1	no
2	atdma	a-long	16qam	64	no	0x9	0xE8	0x152	0	22	yes	yes	0	qpsk1	no
2	atdma	a-ugs	16qam	64	no	0x9	0xE8	0x152	0	22	yes	yes	0	qpsk1	no
21	tdma	request	qpsk	36	no	0x0	0x10	0x152	0	22	no	yes	0	qpsk	na
21	tdma	initial	qpsk	98	no	0x5	0x22	0x152	0	48	no	yes	0	qpsk	na
21	tdma	station	qpsk	98	no	0x5	0x22	0x152	0	48	no	yes	0	qpsk	na
21	tdma	short	qpsk	64	no	0x3	0x4C	0x152	12	22	yes	yes	0	qpsk	na
21	tdma	long	qpsk	64	no	0x9	0xE8	0x152	0	22	yes	yes	0	qpsk	na
121	mixed	request	qpsk	36	no	0x0	0x10	0x152	0	22	no	yes	0	qpsk	na
121	mixed	initial	qpsk	98	no	0x5	0x22	0x152	0	48	no	yes	0	qpsk	na
121	mixed	station	qpsk	98	no	0x5	0x22	0x152	0	48	no	yes	0	qpsk	na
121	mixed	short	qpsk	64	no	0x3	0x4C	0x152	12	22	yes	yes	0	qpsk	na
121	mixed	long	qpsk	64	no	0x9	0xE8	0x152	0	22	yes	yes	0	qpsk	na
121	mixed	a-short	64qam	64	no	0x6	0x4C	0x152	6	22	yes	yes	0	qpsk1	no
121	mixed	a-long	64qam	64	no	0x9	0xE8	0x152	0	22	yes	yes	0	qpsk1	no
121	mixed	a-ugs	64qam	64	no	0x9	0xE8	0x152	0	22	yes	yes	0	qpsk1	no
221	atdma	request	qpsk	36	no	0x0	0x10	0x152	0	22	no	yes	0	qpsk0	no
221	atdma	initial	qpsk	98	no	0x5	0x22	0x152	0	48	no	yes	0	qpsk0	no
221	atdma	station	qpsk	98	no	0x5	0x22	0x152	0	48	no	yes	0	qpsk0	no
221	atdma	a-short	64qam	64	no	0x6	0x4C	0x152	6	22	yes	yes	0	qpsk1	no
221	atdma	a-long	64qam	64	no	0x9	0xE8	0x152	0	22	yes	yes	0	qpsk1	no

To display a specific modulation profile in detail, specify the profile number with the **show cable modulation-profile** command:

```
Router# show cable modulation-profile 221
```

Mod	Docsis	IUC	Type	Pre len	Diff enco	FEC T	FEC k	Scramb seed	Max B	Guard time	Last CW	Scramb size	Pre offst	Pre Type	RS
	-Mode						BYTE	BYTE	siz	size	short				
221	atdma	request	qpsk	36	no	0x0	0x10	0x152	0	22	no	yes	0	qpsk0	no
221	atdma	initial	qpsk	98	no	0x5	0x22	0x152	0	48	no	yes	0	qpsk0	no
221	atdma	station	qpsk	98	no	0x5	0x22	0x152	0	48	no	yes	0	qpsk0	no
221	atdma	a-short	64qam	64	no	0x6	0x4C	0x152	6	22	yes	yes	0	qpsk1	no
221	atdma	a-long	64qam	64	no	0x9	0xE8	0x152	0	22	yes	yes	0	qpsk1	no
221	atdma	a-ugs	64qam	64	no	0x9	0xE8	0x152	0	22	yes	yes	0	qpsk1	no

## Displaying Cable Modem Capabilities and Provisioning

To display the capabilities of the online cable modems and how the modems were provisioned, use the **show cable modem mac** command:

## Displaying Cable Modem Capabilities and Provisioning

```
Router# show cable modem mac
```

MAC Address	MAC State	Prim Sid	Ver	QoS Prov	Frag	Concat	PHS	Priv	DS Sids	US Sids
1859.334d.7b4c	init(i)	145	DOC1.0	DOC1.0	no	no	no		0	0
1859.334d.fa8c	offline	146	DOC1.0	DOC1.0	no	no	no		0	0
1859.334d.fa02	offline	147	DOC1.0	DOC1.0	no	no	no		0	0
1859.334d.65b0	online(pt)	148	DOC3.0	DOC1.1	yes	yes	yes	BPI+	15	16
1859.334d.6622	offline	149	DOC1.0	DOC1.0	no	no	no		0	0
1859.334d.7a50	init(i)	150	DOC1.0	DOC1.0	no	no	no		0	0
1859.334d.7a2e	offline	151	DOC1.0	DOC1.0	no	no	no		0	0
1859.334d.7d14	online(pt)	152	DOC2.0	DOC1.1	yes	yes	yes	BPI+	15	16
1859.334d.6636	online(pt)	153	DOC2.0	DOC1.1	yes	yes	yes	BPI+	15	16
1859.334d.7cf0	online(pt)	154	DOC2.0	DOC1.1	yes	yes	yes	BPI+	15	16
1859.334d.6742	online(pt)	155	DOC2.0	DOC1.1	yes	yes	yes	BPI+	15	16
1859.334d.7b2a	online(pt)	156	DOC2.0	DOC1.1	yes	yes	yes	BPI+	15	16
1859.334d.7e64	online(pt)	157	DOC2.0	DOC1.1	yes	yes	yes	BPI+	15	16
1859.334d.ede0	online(pt)	158	DOC2.0	DOC1.1	yes	yes	yes	BPI+	15	16
1859.334d.7b8a	online(pt)	159	DOC2.0	DOC1.1	yes	yes	yes	BPI+	15	16
1859.334d.6604	online(pt)	160	DOC2.0	DOC1.1	yes	yes	yes	BPI+	15	16
1859.334d.f93a	online(pt)	161	DOC2.0	DOC1.1	yes	yes	yes	BPI+	15	16
1859.334d.7bf0	online(pt)	162	DOC2.0	DOC1.1	yes	yes	yes	BPI+	15	16
1859.334d.596a	online(pt)	163	DOC2.0	DOC1.1	yes	yes	yes	BPI+	15	16
1859.334d.7d38	online(pt)	164	DOC2.0	DOC1.1	yes	yes	yes	BPI+	15	16
1859.334d.fc64	online(pt)	165	DOC2.0	DOC1.1	yes	yes	yes	BPI+	15	16
1859.334d.6434	online(pt)	166	DOC2.0	DOC1.1	yes	yes	yes	BPI+	15	16
1859.334d.f62a	online(pt)	167	DOC2.0	DOC1.1	yes	yes	yes	BPI+	15	16

!

To display how many cable modems of each DOCSIS type are online each upstream, use the **show cable modem mac summary** command:

```
Router# show cable modem mac summary
```

```

Cable Modem Summary
-----

```

Interface	Total	Mac Version				QoS Provision Mode		
		DOC3.0	DOC2.0	DOC1.1	DOC1.0	Reg/Online	DOC1.1	DOC1.0
Cable3/0/1/U0	20	0	5	0	15	5	5	0
Cable3/0/1/U1	23	0	9	0	14	9	9	0
Cable3/0/1/U2	21	0	8	0	13	8	8	0
Cable3/0/1/U4	42	0	9	0	33	9	9	0
Cable3/0/1/U5	20	0	15	0	5	15	15	0
Cable3/0/1/U6	18	1	14	0	3	15	15	0
Cable3/0/2/U0	26	0	26	0	0	26	26	0
Cable3/0/2/U1	28	0	28	0	0	28	28	0
Cable3/0/2/U2	24	0	24	0	0	24	24	0
Cable3/0/2/U4	72	0	72	0	0	72	72	0
Cable3/0/3/U0	67	0	63	0	4	63	63	0
Cable3/0/3/U1	85	1	84	0	0	85	85	0
Cable3/0/3/U2	1	0	1	0	0	1	1	0
Cable3/0/4/U0	12	0	1	0	11	1	1	0
Cable3/0/4/U1	39	0	0	0	39	0	0	0
Cable3/0/4/U2	12	0	1	0	11	1	1	0
Cable3/0/4/U4	65	0	11	0	54	11	11	0
Cable3/0/4/U5	10	0	10	0	0	10	10	0
Cable3/0/4/U6	5	0	5	0	0	5	5	0
Cable3/0/5/U0	27	0	27	0	0	27	27	0
Cable3/0/5/U1	27	0	27	0	0	27	27	0
Cable3/0/5/U2	26	0	26	0	0	26	26	0
Cable3/0/5/U4	77	0	77	0	0	77	77	0
Cable3/0/6/U4	14	14	0	0	0	14	14	0
Cable3/0/6/U5	12	12	0	0	0	12	12	0

```
Cable3/0/6/U6      5      5      0      0      0      5      5      0
```

## Configuration Examples for DOCSIS 2.0 A-TDMA services

This section contains the following:

### Creating Modulation Profiles Examples

This section contains the following:

#### Example: DOCSIS 1.0/DOCSIS 1.1 TDMA Modulation Profiles

The following sample configurations show typical modulation profiles for the DOCSIS 1.0/DOCSIS 1.1 TDMA mode of operation:

- Profile 21 is the default profile for TDMA operations.
- Profiles 24 and 25 use the preconfigured 16-QAM and QPSK modulation profiles.
- Profile 26 is a typical QPSK modulation profile using some customized burst parameters.

```
cable modulation-profile 24 tdma qam-16
cable modulation-profile 25 tdma qpsk
cable modulation-profile 26 tdma request 0 16 0 8 qpsk scrambler 152 no-diff 68 fixed
cable modulation-profile 26 tdma initial 5 34 0 48 qpsk scrambler 152 no-diff 128 fixed
cable modulation-profile 26 tdma station 5 34 0 48 qpsk scrambler 152 no-diff 128 fixed
cable modulation-profile 26 tdma short 4 76 12 8 qpsk scrambler 152 no-diff 80 shortened
cable modulation-profile 26 tdma long 8 236 0 8 qpsk scrambler 152 no-diff 80 shortened
```

#### Example: Mixed TDMA/A-TDMA Modulation Profiles

The following sample configurations show typical modulation profiles for the DOCSIS 1.X/DOCSIS 2.0 mixed TDMA/A-TDMA mode of operation:

- Profile 121 is the default profile for mixed mode operations.
- Profiles 122 through 126 use the preconfigured mixed mode modulation profiles.
- Profile 127 is a typical mixed mode modulation profile some customized burst parameters.

```
cable modulation-profile 121 mixed request 0 16 0 8 qpsk scrambler 152 no-diff 64 fixed
cable modulation-profile 121 mixed initial 5 34 0 48 qpsk scrambler 152 no-diff 32 fixed
cable modulation-profile 121 mixed station 5 34 0 48 qpsk scrambler 152 no-diff 32 fixed
cable modulation-profile 121 mixed short 5 75 6 8 qpsk scrambler 152 no-diff 72 shortened
cable modulation-profile 121 mixed long 8 220 0 8 qpsk scrambler 152 no-diff 80 shortened
cable modulation-profile 121 mixed a-short 0 16 15 99 64qam scrambler 152 no-diff 128
shortened qpsk0 0 18
cable modulation-profile 121 mixed a-long 0 16 15 200 64qam scrambler 152 no-diff 128
shortened qpsk0 0 18

cable modulation-profile 122 mixed mix-high
cable modulation-profile 123 mixed mix-low
cable modulation-profile 124 mixed mix-medium
cable modulation-profile 125 mixed qam-16
cable modulation-profile 126 mixed qpsk

cable modulation-profile 127 mixed request 0 16 0 8 qpsk scrambler 152 no-diff 68 fixed
cable modulation-profile 127 mixed initial 5 34 0 48 qpsk scrambler 152 no-diff 128 fixed
cable modulation-profile 127 mixed station 5 34 0 48 qpsk scrambler 152 no-diff 128 fixed
cable modulation-profile 127 mixed short 6 76 7 8 16qam scrambler 152 no-diff 160 shortened
```

```

cable modulation-profile 127 mixed long 8 231 0 8 16qam scrambler 152 no-diff 160 shortened
cable modulation-profile 127 mixed a-short 9 76 6 8 32qam scrambler 152 no-diff 160 shortened
  qpsk1 1 2048
cable modulation-profile 127 mixed a-long 12 231 0 8 64qam scrambler 152 no-diff 132 shortened
  qpsk1 1 2048

```

## Example: DOCSIS 2.0 A-TDMA Modulation Profiles

The following sample configurations show typical modulation profiles for the DOCSIS 2.0 A-TDMA mode of operation:

- Profile 221 is the default profile for A-TDMA mode operations.
- Profiles 222 through 226 use the preconfigured A-TDMA mode modulation profiles.
- Profile 227 is a typical A-TDMA mode modulation profile customized burst parameters.

```

cable modulation-profile 221 atdma request 0 16 0 8 qpsk scrambler 152 no-diff 64 fixed
  qpsk0 0 18
cable modulation-profile 221 atdma initial 5 34 0 48 qpsk scrambler 152 no-diff 32 fixed
  qpsk0 0 18
cable modulation-profile 221 atdma station 5 34 0 48 qpsk scrambler 152 no-diff 32 fixed
  qpsk0 0 18
cable modulation-profile 221 atdma short 5 75 6 8 qpsk scrambler 152 no-diff 72 shortened
  qpsk0 0 18
cable modulation-profile 221 atdma long 8 220 0 8 qpsk scrambler 152 no-diff 80 shortened
  qpsk0 0 18
cable modulation-profile 221 atdma a-short 5 99 10 8 64qam scrambler 152 no-diff 128 shortened
  qpsk0 0 18
cable modulation-profile 221 atdma a-long 15 200 0 8 64qam scrambler 152 no-diff 128 shortened
  qpsk0 0 18

cable modulation-profile 222 atdma qam-8
cable modulation-profile 223 atdma qam-16
cable modulation-profile 224 atdma qam-32
cable modulation-profile 225 atdma qam-64
cable modulation-profile 226 atdma qpsk

cable modulation-profile 227 atdma request 0 16 0 8 qpsk scrambler 152 no-diff 68 fixed
  qpsk0 1 2048
cable modulation-profile 227 atdma initial 0 16 0 0 qpsk no-scrambler no-diff 2 fixed qpsk1
  0 18
cable modulation-profile 227 atdma station 5 34 0 48 qpsk scrambler 152 no-diff 128 fixed
  qpsk0 1 2048
cable modulation-profile 227 atdma a-short 9 76 6 8 32qam scrambler 152 no-diff 160 shortened
  qpsk1 1 2048
cable modulation-profile 227 atdma a-long 12 231 0 8 64qam scrambler 152 no-diff 132 shortened
  qpsk1 1 2048
cable modulation-profile 227 atdma a-ugs 3 231 0 8 16qam scrambler 152 no-diff 80 shortened
  qpsk1 1 2048

```

## Assigning Modulation Profiles to Upstreams Examples

This section contains the following:



## Example: Assigning DOCSIS 1.0/DOCSIS 1.1 TDMA Modulation Profiles

The following sample configuration shows DOCSIS 1.0/DOCSIS 1.1 TDMA modulation profiles being assigned to the upstreams. The TDMA modulation profile (profile 21) is assigned to the upstream controller 2/0/0.

```
controller Upstream-Cable 2/0/0
  us-channel 0 channel-width 1600000 1600000
  us-channel 0 docsis-mode tdma
  us-channel 0 minislots-size 4
  us-channel 0 modulation-profile 21
  no us-channel 0 shutdown
  us-channel 1 channel-width 1600000 1600000
  us-channel 1 docsis-mode tdma
  us-channel 1 minislots-size 4
  us-channel 1 modulation-profile 21
  no us-channel 1 shutdown
  us-channel 2 channel-width 1600000 1600000
  us-channel 2 docsis-mode tdma
  us-channel 2 minislots-size 4
  us-channel 2 modulation-profile 21
  no us-channel 2 shutdown
  us-channel 3 channel-width 1600000 1600000
  us-channel 3 docsis-mode tdma
  us-channel 3 minislots-size 4
  us-channel 3 modulation-profile 21
  no us-channel 3 shutdown
!
```

## Example: Assigning Mixed TDMA/A-TDMA Modulation Profiles

The following sample configuration shows mixed mode TDMA/A-TDMA modulation profiles being assigned to the upstreams. The mixed modulation profile (profile 121) is assigned to the upstream controller 2/0/15.

```
controller Upstream-Cable 2/0/15
  us-channel 0 channel-width 1600000 1600000
  us-channel 0 docsis-mode tdma-atdma
  us-channel 0 minislots-size 4
  us-channel 0 modulation-profile 121
  no us-channel 0 shutdown
  us-channel 1 channel-width 1600000 1600000
  us-channel 1 docsis-mode tdma-atdma
  us-channel 1 minislots-size 4
  us-channel 1 modulation-profile 121
  no us-channel 1 shutdown
  us-channel 2 channel-width 1600000 1600000
  us-channel 2 docsis-mode tdma-atdma
  us-channel 2 minislots-size 4
  us-channel 2 modulation-profile 121
  no us-channel 2 shutdown
  us-channel 3 channel-width 1600000 1600000
  us-channel 3 docsis-mode tdma-atdma
  us-channel 3 minislots-size 4
  us-channel 3 modulation-profile 121
  no us-channel 3 shutdown
!
```

## Example: Assigning DOCSIS 2.0 A-TDMA Modulation Profiles

The following sample configuration shows DOCSIS 2.0 A-TDMA modulation profiles being assigned to the upstreams. The A-TDMA modulation profile (profile 221) is assigned to the upstream controller 2/0/10.

```

controller Upstream-Cable 2/0/10
  us-channel 0 channel-width 1600000 1600000
  us-channel 0 docsis-mode atdma
  us-channel 0 minislots-size 4
  us-channel 0 modulation-profile 221
  no us-channel 0 shutdown
  us-channel 1 channel-width 1600000 1600000
  us-channel 1 docsis-mode atdma
  us-channel 1 minislots-size 4
  us-channel 1 modulation-profile 221
  no us-channel 1 shutdown
  us-channel 2 channel-width 1600000 1600000
  us-channel 2 docsis-mode atdma
  us-channel 2 minislots-size 4
  us-channel 2 modulation-profile 221
  no us-channel 2 shutdown
  us-channel 3 channel-width 1600000 1600000
  us-channel 3 docsis-mode atdma
  us-channel 3 minislots-size 4
  us-channel 3 modulation-profile 221
  no us-channel 3 shutdown
  us-channel 4 channel-width 1600000 1600000
  us-channel 4 docsis-mode atdma
  us-channel 4 minislots-size 4
  us-channel 4 modulation-profile 221
  us-channel 4 shutdown
  us-channel 5 channel-width 1600000 1600000
  us-channel 5 docsis-mode atdma
  us-channel 5 minislots-size 4
  us-channel 5 modulation-profile 221
  us-channel 5 shutdown
!
```

## Additional References

### Related Documents

Related Topic	Document Title
Cisco CMTS Commands	<i>Cisco IOS CMTS Cable Command Reference</i> <a href="http://www.cisco.com/en/US/docs/ios/cable/command/reference/cbl_book.html">http://www.cisco.com/en/US/docs/ios/cable/command/reference/cbl_book.html</a>

### Standards

Standards	Title
SP-RFIV1.1-I09-020830	Data-over-Cable Service Interface Specifications Radio Frequency Interface Specification, version 1.1
SP-RFIV2.0-I03-021218	Data-over-Cable Service Interface Specifications Radio Frequency Interface Specification, version 2.0
SP-OSSIV2.0-I03-021218	Data-over-Cable Service Interface Specifications Operations Support System Interface Specification, version 2.0

Standards	Title
SP-BPI+-I09-020830	Data-over-Cable Service Interface Specifications Baseline Privacy Plus Interface Specification, version 2.0
RFC 2233	DOCSIS OSSI Objects Support
RFC 2665	DOCSIS Ethernet MIB Objects Support
RFC 2669	Cable Device MIB

### MIBs

MIBs	MIBs Link
<ul style="list-style-type: none"> <li>• DOCS-BPI-PLUS-MIB</li> <li>• DOCS-CABLE-DEVICE-MIB (RFC 2669)</li> <li>• DOCS-CABLE-DEVICE-TRAP-MIB</li> <li>• DOCS-IF-EXT-MIB</li> <li>• DOCS-IF-MIB (RFC 2670)</li> <li>• DOCS-QOS-MIB</li> <li>• DOCS-SUBMGT-MIB</li> <li>• IGMP-STD-MIB (RFC 2933)</li> </ul>	<p>To locate and download MIBs for selected platforms, Cisco IOS releases, and feature sets, use Cisco MIB Locator found at the following URL:</p> <p><a href="http://www.cisco.com/go/mibs">http://www.cisco.com/go/mibs</a></p>

### Technical Assistance

Description	Link
<p>The Cisco Support website provides extensive online resources, including documentation and tools for troubleshooting and resolving technical issues with Cisco products and technologies.</p> <p>To receive security and technical information about your products, you can subscribe to various services, such as the Product Alert Tool (accessed from Field Notices), the Cisco Technical Services Newsletter, and Really Simple Syndication (RSS) Feeds.</p> <p>Access to most tools on the Cisco Support website requires a Cisco.com user ID and password.</p>	<p><a href="http://www.cisco.com/support">http://www.cisco.com/support</a></p>

## Feature Information for DOCSIS 2.0 A-TDMA Modulation Profile

Use Cisco Feature Navigator to find information about the platform support and software image support. Cisco Feature Navigator enables you to determine which software images support a specific software release, feature set, or platform. To access Cisco Feature Navigator, go to the <https://cfmng.cisco.com/> link. An account on the Cisco.com page is not required.



**Note** The following table lists the software release in which a given feature is introduced. Unless noted otherwise, subsequent releases of that software release train also support that feature.

**Table 63: Feature Information for DOCSIS 2.0 A-TDMA Modulation Profile**

Feature Name	Releases	Feature Information
DOCSIS 2.0 A-TDMA Modulation Profile	Cisco IOS XE Fuji 16.7.1	This feature was integrated on the cisco cBR Series Converged Broadband Routers.



## CHAPTER 21

# Downstream Resiliency Bonding Group

With more wideband (WB) modems being deployed in cable plants, WB modem resiliency is an important feature. When a comparatively smaller number of cable modems (CMs) observe an impairment on an RF channel, that RF channel stops working. It impacts all the CM using that RF channel, irrespective of whether they reported the impairment on that RF channel. Instead, the solution should be to communicate with the affected cable modems using the good RF channel, without affecting the other cable modems.

The Downstream Resiliency Bonding Group feature allows cable modems with multiple impaired RF channels to be allocated to a dynamically-created wideband interface, which ensures that the performance of the wideband cable modems is not drastically affected.

Your software release may not support all the features that are documented in this module. For the latest feature information and caveats, see the release notes for your platform and software release. The Feature Information Table at the end of this document provides information about the documented features and lists the releases in which each feature is supported.

Use Cisco Feature Navigator to find information about platform support and Cisco software image support. To access Cisco Feature Navigator, go to <http://tools.cisco.com/ITDIT/CFN/>. An account on <http://www.cisco.com/> is not required.

### Contents

- [Hardware Compatibility Matrix for the Cisco cBR Series Routers](#), on page 362
- [Prerequisites for Downstream Resiliency Bonding Group](#), on page 363
- [Restrictions for the Downstream Resiliency Bonding Group](#), on page 363
- [Information About Downstream Resiliency Bonding Group](#), on page 364
- [How to Configure Downstream Resiliency Bonding Group](#), on page 366
- [Moving a DS Partial Cable Modem Back to the Original BG](#), on page 368
- [Verifying Downstream Resiliency Bonding Group Configuration](#), on page 368
- [Troubleshooting the Downstream Resiliency Bonding Group Configuration](#), on page 373
- [Configuration Examples for the Downstream Resiliency Bonding Group](#), on page 373
- [Excluding Cable Modems from Downstream Resiliency Operations](#), on page 377
- [Additional References](#), on page 378
- [Feature Information for Downstream Resiliency Bonding Group](#), on page 378

# Hardware Compatibility Matrix for the Cisco cBR Series Routers



**Note** The hardware components that are introduced in a given Cisco IOS-XE Release are supported in all subsequent releases unless otherwise specified.

**Table 64: Hardware Compatibility Matrix for the Cisco cBR Series Routers**

Cisco CMTS Platform	Processor Engine	Interface Cards
Cisco cBR-8 Converged Broadband Router	<p><b>Cisco IOS-XE Release 16.5.1 and Later Releases</b></p> <p>Cisco cBR-8 Supervisor:</p> <ul style="list-style-type: none"> <li>• PID—CBR-SUP-250G</li> <li>• PID—CBR-CCAP-SUP-160G</li> </ul>	<p><b>Cisco IOS-XE Release 16.5.1 and Later Releases</b></p> <p>Cisco cBR-8 CCAP Line Cards:</p> <ul style="list-style-type: none"> <li>• PID—CBR-LC-8D30-16U30</li> <li>• PID—CBR-LC-8D31-16U30</li> <li>• PID—CBR-RF-PIC</li> <li>• PID—CBR-RF-PROT-PIC</li> <li>• PID—CBR-CCAP-LC-40G</li> <li>• PID—CBR-CCAP-LC-40G-R</li> <li>• PID—CBR-CCAP-LC-G2-R</li> <li>• PID—CBR-SUP-8X10G-PIC</li> <li>• PID—CBR-2X100G-PIC</li> </ul> <p>Digital PICs:</p> <ul style="list-style-type: none"> <li>• PID—CBR-DPIC-8X10G</li> <li>• PID—CBR-DPIC-2X100G</li> </ul> <p>Cisco cBR-8 Downstream PHY Module:</p> <ul style="list-style-type: none"> <li>• PID—CBR-D31-DS-MOD</li> </ul> <p>Cisco cBR-8 Upstream PHY Modules:</p> <ul style="list-style-type: none"> <li>• PID—CBR-D31-US-MOD</li> </ul>



**Note** Do not use DPICs (8X10G and 2x100G) to forward IP traffic, as it may cause buffer exhaustion, leading to line card reload.

The only allowed traffic on a DPIC interface is DEPI, UEPI, and GCP traffic from the Cisco cBR-8 router to Remote PHY devices. Other traffic such as DHCP, SSH, and UTSC should flow via another router, since DPICs cannot be used for normal routing.

## Prerequisites for Downstream Resiliency Bonding Group

- Set aside WB interfaces so that new WB interfaces can be dynamically created from the reserved list of WB interfaces.
- Free up RF bandwidth so that those RF channels can be added to a resiliency bonding group (RBG).
- Remove all existing RBG configuration from the WB interface.

## Restrictions for the Downstream Resiliency Bonding Group

- If an existing wideband interface is reserved as a Resiliency Bonding Group (RBG) and later the RBG is removed (through the **no cable ds-resiliency** command), the modems using this RBG go offline and the RBG configuration itself is deleted. Therefore, it is highly recommended that users should not configure an existing BG as an RBG.
- This feature is enabled only when the number of cable modems observing an RF channel impairment is *below* the resiliency threshold. If the number of cable modems on an impaired RF channel is above the resiliency threshold, the impaired RF channel is temporarily removed from the bonding group.
- A cable modem is assigned to an RBG on a first-come-first-served basis. To handle this feature optimally, it is recommended to set aside more WB interfaces and RF channel bandwidth.
- The Cisco CMTS controls the freeing of unused RBGs, when there is no modem using the RGB. The freeing of the unused RGB may take some time and the RGB, which is not completely free cannot be used by the modems. Irrespective of the number of configured RBGs, if all the old RBGs are not completely set free and if the Cisco CMTS tries to move the cable modem to a new RBG, the Cisco CMTS moves the cable modem to the primary DS channel instead of RBG.
- Only SFs on the WB interface associated with the primary SF are moved to an RBG. SFs on other interfaces will not be moved.
- Static SFs are assigned to an RBG on a best effort quality of service (QoS).
- If the **resiliency rf-change-trigger** setting does not have the **secondary** keyword set, only the primary SF is moved to the RBG or a NB interface.
- If the Downstream Resiliency Bonding Group feature is not enabled to use an RBG, only cable modems with impairments on the primary WB interface are moved to the NB interface.
- SFs carrying multicast traffic are not moved.

There may not be enough reserved bonding groups to support all modems facing an impairment at any given time thus the following restrictions must be considered:

- Each RBG has at least two RF channels.
- RBG RF assignments are always a subset of the RF channel assignment of the parent WB interface.
- If an RBG is unavailable for a cable modem, the SF of the CM is moved to a NB interface.
- If a high percentage of cable modems experience an RF impairment and there are no more available bonding group IDs, the impaired RF itself may be removed from the bonding group. Removal of an impaired RF from a parent bonding group is also reflected in the RBG. If an RBG drops to a single RF, all SFs are moved to the NB interface.

The Downstream Resiliency Bonding Group feature has the following cross-functional restrictions:

- All Dynamic service flows, whether they require a committed information rate (CIR) or not, typically voice flows, are created on the NB interface when an RF channel is impaired. Because all SFs assigned to an RBG are best effort only, voice calls may report a quality issue.
- Cable modems participating in the resiliency mode do not take part in load balancing.
- The Downstream Resiliency Bonding Group feature is only supported in the Dynamic Bandwidth Sharing (DBS) mode.

## Information About Downstream Resiliency Bonding Group

You can set aside unused bonding groups as RBGs. Ensure that each RF channel is assigned at least 1% of the available bandwidth. Use the **cable rf-channel bandwidth-percent** command to configure the RF channel bandwidth.



---

**Note** If the bandwidth-percent is set to 100, the Cisco CMTS does not add any RFs to the RBG. In other words, this feature will not be enabled.

---

The Cisco CMTS controls the assignment and freeing of unused RBGs. If an RF channel is removed from a WB interface, it is also removed from any associated RBGs.



---

**Note** If the wideband interface is in standby mode, the Cisco CMTS does not assign or free up the unused downstream bonding group.

---

A suspended RF channel is restored for all affected wideband interfaces when a specified number of cable modems report (via CM-STATUS) that the channel connectivity is restored. The Wideband Modem Resiliency feature defines the specified number of cable modems as half of the configured count or percentage of rf-change-trigger, or both. For example, if the count is 20 and the percent is 10, then the number of cable modems reporting recovery should reduce the count to 10 and the percent to 5 for the suspended RF channel to be restored.



Table 65: Feature History

Feature Name	Release Information	Feature Description
Configuring maximum RBG moves and viewing CM RBG usage statistics.	Cisco IOS XE Dublin 17.12.1w	<p>If a CM is currently at the configured limit, and it reports a new DS impairment, the CM moves to narrow band (primary DS only). CM-STATUS recovery events are still handled for CMs that are currently at the configured limit.</p> <p>You can use the <a href="#">cable resiliency cm-max-rbg-moves</a> command to configure the maximum number of times a CM can be moved to any RBG within the configured interval.</p> <p>Use the <a href="#">show cable modem rbg-activity</a> to view CM RBG usage statistics.</p>

## Finding a Best-Fit RBG for the Cable Modem

A bonding group is a list of channels that provide a means to identify the channels that are bonded together. The Cisco CMTS assigns a service flow (SF) to an RBG based on the attributes of the SF and the attributes of the individual channels of the bonding group.

In the Downstream Resiliency Bonding Group feature, when a line card receives a CM-STATUS message from the cable modem informing the line card that there is an RF channel impairment, the line card checks for the number of good RF channels and:

- Moves the cable modem to narrowband mode if there is only one available RF channel.
- Moves the cable modem to wideband mode if the cable modem reports all RF channels are in good state.
- Moves the cable modem to an RBG if there are two or more good RF channels, with at least one RF channel impaired, and if the Downstream Resiliency Bonding Group feature is enabled.

When the Cisco CMTS receives a message from the line card to move a cable modem to an RBG, the Cisco CMTS attempts to find an existing RBG or creates an RBG that satisfies the impairment.



**Note** If two or more RBGs are reserved for the same wideband controller, the Cisco CMTS creates one RBG for each cable modem.



**Note** The Cisco CMTS creates more than one RBG from a parent WB interface if the user has set aside more than one WB interface as the RBG and the RF bandwidth does not exceed 100%.

If a matching RBG is not found or cannot be created, the Cisco CMTS looks for an RBG with a subset of the required RF channels and if available, the cable modem is assigned to such an RBG.

However, if no such RBG exists, the Cisco CMTS instructs the line card to move the cable modem to NB mode.

Table 66: Feature History

Feature Name	Release Information	Feature Description
Resiliency Bonding Group (RBG) Commands	Cisco IOS XE Dublin 17.12.1w	<p>In this release you can:</p> <ul style="list-style-type: none"> <li>Use the <b>cable resiliency cm-max-rbg-moves</b> command to configure the maximum number of times a CM can be moved to any RBG within the configured interval. This allows you to have better control on CM movement in a specified duration.</li> <li>Use the <b>show cable modem rbg-activity</b> command to view CM RBG usage statistics.</li> </ul>

# How to Configure Downstream Resiliency Bonding Group

This section contains the following:

## Enabling Downstream Resiliency Bonding Group

### Procedure

	Command or Action	Purpose
<b>Step 1</b>	<b>enable</b> <b>Example:</b> Router> <b>enable</b>	Enables privileged EXEC mode. <ul style="list-style-type: none"> <li>Enter your password if prompted.</li> </ul>
<b>Step 2</b>	<b>configure terminal</b> <b>Example:</b> Router# <b>configure terminal</b>	Enters global configuration mode.
<b>Step 3</b>	<b>cable rf-change-trigger {percent value   count number} [secondary]</b> <b>Example:</b> Router(config)# <b>cable rf-change-trigger percent 50 count 1 secondary</b>	Specifies the amount of time an event must persist before it triggers an action for the reporting CM.
<b>Step 4</b>	<b>cable resiliency ds-bonding</b> <b>Example:</b> Router(config)# <b>cable resiliency ds-bonding</b>	Enables the downstream resiliency bonding group.
<b>Step 5</b>	<b>exit</b> <b>Example:</b> Router(config)# <b>exit</b>	Returns to the global configuration mode.

**What to do next**

**Note** The result of using the **cable rf-change-trigger** command with the **cable resiliency ds-bonding** command is different from using only the **cable rf-change-trigger** command. For more information, see [Downstream Resiliency Narrowband Mode Versus Resiliency Bonding Group](#), on page 369.

## Reserving a Resiliency Bonding Group for a Line Card

This section describes reserving a bonding group or a wideband interface for a line card per controller.



**Restriction** When you reserve a resiliency bonding group using the **cable ds-resiliency** command, the existing bundle and RF channel configurations on the wideband interface will be removed automatically. Other configurations like admission control, should be removed manually.

After downstream resiliency bonding group is configured, avoid other manual configurations.

**Procedure**

	Command or Action	Purpose
<b>Step 1</b>	<b>enable</b> <b>Example:</b> Router> <b>enable</b>	Enables privileged EXEC mode. <ul style="list-style-type: none"><li>• Enter your password if prompted.</li></ul>
<b>Step 2</b>	<b>configure terminal</b> <b>Example:</b> Router# <b>configure terminal</b>	Enters global configuration mode.
<b>Step 3</b>	<b>interface wideband-cable</b> <i>slot/subslot/port:wideband-channel</i> <b>Example:</b> Router(config)# <b>interface wideband-cable 1/0/0:7</b>	Configures a wideband cable interface.
<b>Step 4</b>	<b>cable ds-resiliency</b> <b>Example:</b> Router(config-if)# <b>cable ds-resiliency</b>	Reserves an individual bonding group or WB interface for usage on a line card, on a per controller basis.
<b>Step 5</b>	<b>exit</b> <b>Example:</b> Router(config-if)# <b>exit</b>	Returns to the global configuration mode.

# Moving a DS Partial Cable Modem Back to the Original BG

Table 67: Feature History

Feature Name	Release Information	Feature Description
Moving a DS Partial Cable Modem Back to the Original BG	Cisco IOS XE Dublin 17.12.1x	<p>In this release, you can move a DS Partial cable modem back to the original BG. The cable modem remains online and does not reset or reinitialize partial service modems. The cable modem recovers to the <b>w-online</b> state.</p> <p>You can use this feature to recover cable modems that may send the <b>cm-status</b> recovery events which are not received by the cable modem.</p> <p>Cisco can provide the feature details upon request.</p>

## Verifying Downstream Resiliency Bonding Group Configuration

This section contains the following:

### Verifying the Downstream Resiliency Bonding Group

To verify if the Downstream Resiliency Bonding Group feature is enabled, use the **show cable modem resiliency** command as shown in the following example:

```
Router# show cable modem resiliency
          Orig BG
I/F      MAC Address  ID  I/F      RFs ID  I/F      RFs
-----
C7/0/0   0025.2eaf.843e  897  Wi7/0/0:0  4  898  Wi7/0/0:1  3
C7/0/0   0025.2eaf.8356  897  Wi7/0/0:0  4  899  Wi7/0/0:2  3
C7/0/0   0015.d176.5199  897  Wi7/0/0:0  4  720  In7/0/0:0
```

The **Current BG I/F** field indicates whether Downstream Resiliency Bonding Group feature is enabled and if the cable modems are assigned to a WB interface.

Starting with Cisco IOS XE Cupertino 17.9.1w, VTY injection is not used during RBG change, and the system shows the username of the last user who has performed the last configuration update.

To verify the configuration, use the **show running-config** command as shown in the following example:

```
Router# show running-config
oad for five secs: 25%/4%; one minute: 43%; five minutes: 39%
```

```

Time source is NTP, 11:21:16.148 CST Mon Oct 17 2022

Building configuration...

Current configuration : 1305898 bytes
!
! Last configuration change at 08:43:48 CST Mon Oct 17 2022
! NVRAM config last updated at 11:19:42 CST Mon Oct 17 2022 by cstuser
    
```

## Verifying a Reserved Resiliency Bonding Group

To verify if a BG is reserved for a line card, use the **show cable resiliency** command as shown in the following example:

```

Router# show cable resiliency
      BG      Resil BG      RF
Resil BG I/F  ID  State      Count Time      Ctrl Num
-----
Wi1/0/0:10   10  Free
Wi1/0/0:20   20  Free
Wi7/0/0:1     1   Assigned    3   Nov 3  09:55:49 0    0
                                                    1
                                                    2
Wi7/0/0:2     2   Assigned    3   Nov 3  09:57:09 0    0
                                                    1
                                                    3
    
```

## Downstream Resiliency Narrowband Mode Versus Resiliency Bonding Group

This section provides the sample outputs when using the **cable rf-change-trigger** command with the **cable resiliency ds-bonding** command and using only the **cable rf-change-trigger** command.

Table 68: Downstream Resiliency Narrowband Mode Versus Resiliency Bonding Group - Scenario 1

Effect on	Using only cable rf-change-trigger command (Downstream Resiliency NB Mode)		Using cable rf-change-trigger command with cable resiliency ds-bonding (Downstream Resiliency Bonding Group)	
	Below Threshold	Above Threshold	Below Threshold	Above Threshold
Primary Service Flow	Moves to the primary channel.	Remains on the original bonding group while the impaired downstream channels are not used and are reported as DOWN.	Moves to dynamic bonding group.	Remains on the original bonding group while the impaired downstream channels are not used and are reported as DOWN.
Secondary Service Flows	Remain on the original WB interface.	Remains on the original bonding group while the impaired downstream channels are not used and are reported as DOWN.	Remains on the original bonding group.	Remains on the original bonding group while the impaired downstream channels are not used and are reported as DOWN.

The following is a sample output for a cable modem when the **cable rf-change-trigger** command is used with the **cable resiliency ds-bonding** command and the number of cable modems observing an RF channel impairment is *below* the resiliency threshold:

```
Router# show cable modem
```

MAC Address	IP Address	I/F	MAC State	Prim Sid	RxPwr (dBmv)	Timing Offset	Num CPE	D I
0023.be83.1c9e	10.1.11.46	C5/0/0/UB	w-online	922	-0.50	1055	0	N
0023.be83.1caa	10.1.11.28	C5/0/0/UB	w-online	923	0.00	1043	0	N
0025.2ecf.f19c	10.1.11.53	C5/0/0/UB	w-online	925	0.00	1057	0	N
0022.3a30.9fc0	10.1.11.47	C5/0/0/UB	w-online	926	0.00	1055	0	N
<b>001a.c3ff.e3d4</b>	<b>10.1.11.39</b>	<b>C5/0/0/UB</b>	<b>p-online</b>	<b>927</b>	<b>0.00</b>	<b>1307</b>	<b>0</b>	<b>N</b>
0023.be83.1c9a	10.1.11.61	C5/0/0/UB	w-online	928	0.00	1057	0	N
<b>0022.3a30.9fbc</b>	<b>10.1.11.60</b>	<b>C5/0/0/UB</b>	<b>p-online</b>	<b>929</b>	<b>-0.50</b>	<b>1055</b>	<b>0</b>	<b>N</b>
0023.be83.1c8c	10.1.11.38	C5/0/0/UB	w-online	930	0.00	1061	0	N
<b>001e.6bfb.1964</b>	<b>10.1.11.63</b>	<b>C5/0/0/UB</b>	<b>p-online</b>	<b>931</b>	<b>0.50</b>	<b>1305</b>	<b>0</b>	<b>N</b>
0025.2ecf.f196	10.1.11.29	C5/0/0/UB	w-online	932	0.00	1057	0	N
0025.2ecf.f04e	10.1.11.54	C5/0/0/UB	w-online	933	0.00	1054	0	N
0022.3a30.9fc8	10.1.11.43	C5/0/0/UB	w-online	934	0.00	1056	0	N
0025.2ecf.f190	10.1.11.55	C5/0/0/UB	w-online	935	0.00	1059	0	N
<b>0022.3a30.9fd0</b>	<b>10.1.11.52</b>	<b>C5/0/0/UB</b>	<b>p-online</b>	<b>936</b>	<b>0.00</b>	<b>1057</b>	<b>0</b>	<b>N</b>
0022.ce97.8268	10.1.11.31	C5/0/0/UB	w-online	937	-0.50	1056	0	N
0022.ce97.8281	10.1.11.25	C5/0/0/UB	w-online	938	0.00	1058	0	N
001a.c3ff.e4ce	10.1.11.44	C5/0/0/UB	w-online	940	-0.50	1304	0	N
0022.ce9c.839e	10.1.11.32	C5/0/0/UB	w-online	941	-0.50	1305	0	N
0022.cea3.e768	10.1.11.41	C5/0/0/UB	w-online	942	-1.00	1305	0	N
0022.ce9c.8398	10.1.11.33	C5/0/0/UB	w-online	943	0.00	1306	0	N
001a.c3ff.e50a	10.1.11.59	C5/0/0/UB	w-online	944	0.00	1304	0	N
001a.c3ff.e3f8	10.1.11.57	C5/0/0/UB	w-online	945	-1.00	1306	0	N
001e.6bfb.1a14	10.1.11.37	C5/0/0/UB	w-online	946	0.00	1305	0	N



**Note** p-online indicates that cable modem has reported NP RF failure and it is in downstream partial service mode.

```
Router# show cable resiliency
```

Resil BG I/F	BG ID	Resil BG State	Count	Time	RF Ctrl	RF Num
Wi5/0/0:2	2	Assigned	1	Mar 30 14:46:43	0	0
						1
						2
Wi5/0/0:3	3	Assigned	1	Mar 30 14:46:43	0	0
						1
						2
					1	0
						1
						2
						3
Wi5/0/0:4	4	Free	0			
Wi5/0/0:5	5	Free	0			

```
Router# show cable modem resiliency
```

I/F	MAC Address	Orig BG ID	I/F	RFs ID	Curr BG I/F	RFs
C5/0/0	001a.c3ff.e3d4	258	Wi5/0/0:1	4 259	Wi5/0/0:2	3 <- <b>Dynamic Bonding Group</b>
C5/0/0	0022.3a30.9fbc	257	Wi5/0/0:0	8 260	Wi5/0/0:3	7 <- <b>Dynamic Bonding Group</b>
C5/0/0	001e.6bfb.1964	258	Wi5/0/0:1	4 259	Wi5/0/0:2	3 <- <b>Dynamic Bonding Group</b>
C5/0/0	0022.3a30.9fd0	257	Wi5/0/0:0	8 260	Wi5/0/0:3	7 <- <b>Dynamic Bonding Group</b>

The following is a sample output for a cable modem under the following conditions:

- **cable rf-change-trigger** command is used with the **cable resiliency ds-bonding** command
- Number of cable modems observing an RF channel impairment is *below* the resiliency threshold
- There is no available WB interface for the resiliency bonding group:

```
Router# show cable modem
0025.2ecf.f196 service-flow version
```

```
SUMMARY:
MAC Address      IP Address      Host           MAC           Prim Num Primary   DS
                  932  0  In5/0/0:0  240          C5/0/0/UB    State          Sid   CPE Downstream RfId
0025.2ecf.f196  10.1.11.29      p-online
Sfid Dir Curr Sid  Sched Prio MaxSusRate MaxBrst MinRsvRate Throughput
      State      Type
1867 US act  932  BE   0    0          10000      0          294
1868 DS act  N/A  N/A  0    0          3044       0          154
```

```
Router# show cable resiliency
```

Resil	BG	I/F	BG ID	Resil State	Count	Time	RF Ctrl	RF Num
Wi5/0/0:2	2			Assigned	6	Mar 30 15:57:09	0	0 1 2 3 1 0 2 3
Wi5/0/0:3	3			Assigned	8	Mar 30 15:53:58	0	0 1 2 1 1 2 3
Wi5/0/0:4	4			Assigned	2	Mar 30 15:53:58	0	0 1 2 3 1 2 3
Wi5/0/0:5	5			Assigned	2	Mar 30 15:58:35	0	0 1 2 3 1 0 1 3

```
Router# show cable modem resiliency
```

I/F	MAC Address	ID	Orig BG I/F	RFs ID	Curr BG I/F	RFs
C5/0/0	0025.2ecf.f19c	257	Wi5/0/0:0	8 259	Wi5/0/0:2	7
C5/0/0	0025.2ecf.f196	257	Wi5/0/0:0	8 240	In5/0/0:0	<-- move NB for no available

## Downstream Resiliency Narrowband Mode Versus Resiliency Bonding Group

```

WB interface
C5/0/0 0025.2ecf.f04e 257 Wi5/0/0:0 8 262 Wi5/0/0:5 7
C5/0/0 0022.3a30.9fbc 257 Wi5/0/0:0 8 260 Wi5/0/0:3 6
C5/0/0 0022.3a30.9fd0 257 Wi5/0/0:0 8 261 Wi5/0/0:4 7

```

Table 69: Downstream Resiliency Narrowband Mode Versus Resiliency Bonding Group - Scenario 2

Effect on	Using only cable rf-change-trigger secondary command (Downstream Resiliency NB Mode)		Using cable rf-change-trigger secondary command with cable resiliency ds-bonding (Downstream Resiliency Bonding Group)	
	Below Threshold	Above Threshold	Below Threshold	Above Threshold
Primary Service Flow	Moves all service flows to the primary channel.	Remains on the original bonding group while the impaired downstream channels are not used and are reported as DOWN.	Moves all service flows to a dynamic bonding group.	Remains on the original bonding group while the impaired downstream channels are not used and are reported as DOWN.
Secondary Service Flows				

The following is a sample output for a cable modem when the **cable rf-change-trigger secondary** command is used with the **cable resiliency ds-bonding** command and the number of cable modems observing an RF channel impairment is *below* the resiliency threshold:

```

Router# show cable modem 0025.2ecf.f196 service-flow

SUMMARY:
MAC Address      IP Address      Host          MAC          Prim Num Primary DS
                  State          Interface     State          Sid  CPE Downstream RfId
0025.2ecf.f196  10.1.11.29     C5/0/0/UB    p-online     955  0   In5/0/0:0  240
Sfid  Dir  Curr  Sid  Sched  Prio MaxSusRate  MaxBrst  MinRsvRate  Throughput
      State
1913  US  act   955  BE     0    10000000    10000    0            425
1915  US  act   956  RTPS   7     0           3044    100000      0
1916  US  act   957  BE     0     0           3044    50000      0
1917  US  act   958  BE     4     0           3044     0           0
1914  DS  act   N/A  N/A    0    100000000   20000    0           0      <-- Primary
Service-Flow
1918  DS  act   N/A  N/A    0     0           3044     0           0      <-- Secondary
Service-Flow
1919  DS  act   N/A  N/A    0     0           3044     0           0      <-- Secondary
Service-Flow
1920  DS  act   N/A  N/A    4    4500000     3044     0           0      <-- Secondary
Service-Flow
UPSTREAM SERVICE FLOW DETAIL:
SFID  SID  Requests  Polls  Grants  Delayed  Dropped  Packets
      Grants
1913  955  83         0      83      0        0        92
1915  956  0          0      0        0        0        0
1916  957  0          0      0        0        0        0
1917  958  0          0      0        0        0        0
DOWNSTREAM SERVICE FLOW DETAIL:
SFID  RP_SFID  QID  Flg  Policer  Xmits  Drops  Scheduler  Drops  FrwdIF
      Xmits  Drops  Xmits  Drops
1914  33210  131555  90   0        0      0      6          0      Wi5/0/0:3 <-- Dynamic
Bonding Group
1918  33211  131556  0    0        0      0      0          0      Wi5/0/0:3

```



1919	33212	131557	0	0	0	0	Wi5/0/0:3
1920	33213	131558	0	0	0	0	Wi5/0/0:3

## Troubleshooting the Downstream Resiliency Bonding Group Configuration

Use the following commands to get information on the WB interface, number of CMs in an impaired state, resiliency bonding groups, their associated bonding groups, available RF channels, and the number of CMS and service flows assigned to them:

- **debug cable wbcmts resiliency**
- **debug cable wbcmts resiliency report**
- **show cable resiliency**
- **show cable modem resiliency**
- **show cable modem wideband rcs-status**
- **show cable modem service-flow verbose**
- **show cable resil-rf-status**
- **show cable modem summary wb-rfs**

In case the CPU usage of the downstream resiliency process is high, use following commands to optimize the downstream resiliency bonding group configuration:

- **cable rf-change-up-multiplier *value*** - The default value is 2. Use this command to set the rf-channel up dampen time as an integer multiplier of the rf-channel down dampen time, in order to lengthen the recovery time to keep certain modems from falling back into DOWN state shortly after recovery.
- **cable resiliency free-interval *seconds*** - The recommended value is 360. Use this command to set the wait time before a created resiliency bonding group is freed/recycled, in order to hold the resiliency bonding group up long enough for it to be reused by impaired cable modems.

## Configuration Examples for the Downstream Resiliency Bonding Group

The following is an example of the configuration of the Downstream Resiliency Bonding Group feature:

```
cable rf-change-trigger count 10 secondary
cable resiliency ds-bonding
!
controller Upstream-Cable 9/0/1
us-channel 0 frequency 13200000
us-channel 0 channel-width 6400000 6400000
us-channel 0 power-level -1
us-channel 0 docsis-mode atdma
us-channel 0 minislots-size 8
us-channel 0 modulation-profile 221
no us-channel 0 shutdown
```

```

us-channel 1 frequency 19600000
us-channel 1 channel-width 6400000 6400000
us-channel 1 power-level -1
us-channel 1 docsis-mode atdma
us-channel 1 minislot-size 8
us-channel 1 modulation-profile 221
no us-channel 1 shutdown
us-channel 2 frequency 26000000
us-channel 2 channel-width 6400000 6400000
us-channel 2 power-level -1
us-channel 2 docsis-mode atdma
us-channel 2 minislot-size 8
us-channel 2 modulation-profile 221
no us-channel 2 shutdown
us-channel 3 frequency 32400000
us-channel 3 channel-width 6400000 6400000
us-channel 3 power-level -1
us-channel 3 docsis-mode atdma
us-channel 3 minislot-size 8
us-channel 3 modulation-profile 221
no us-channel 3 shutdown
!
controller Integrated-Cable 9/0/1
max-carrier 128
base-channel-power 34
rf-chan 0
  type DOCSIS
  frequency 381000000
  rf-output NORMAL
  power-adjust -2
  docsis-channel-id 1
  qam-profile 1
rf-chan 1 3
  type DOCSIS
  frequency 387000000
  rf-output NORMAL
  power-adjust 0
  docsis-channel-id 2
  qam-profile 1
rf-chan 32 35
  type DOCSIS
  frequency 477000000
  rf-output NORMAL
  power-adjust 0
  docsis-channel-id 33
  qam-profile 1
rf-chan 64 67
  type DOCSIS
  frequency 501000000
  rf-output NORMAL
  power-adjust 0
  docsis-channel-id 65
  qam-profile 1
rf-chan 96 99
  type DOCSIS
  frequency 669000000
  rf-output NORMAL
  power-adjust 0
  docsis-channel-id 97
  qam-profile 1
!
interface Cable9/0/1
downstream Integrated-Cable 9/0/1 rf-channel 0-3
downstream Integrated-Cable 9/0/1 rf-channel 32-35

```

```

upstream 0 Upstream-Cable 9/0/1 us-channel 0
upstream 1 Upstream-Cable 9/0/1 us-channel 1
upstream 2 Upstream-Cable 9/0/1 us-channel 2
upstream 3 Upstream-Cable 9/0/1 us-channel 3
cable upstream bonding-group 1
    upstream 0
    upstream 1
    upstream 2
    attributes 80000000
cable upstream bonding-group 2
    upstream 0
    upstream 1
    attributes 80000000
cable upstream bonding-group 3
    upstream 1
    upstream 2
    attributes 80000000
cable upstream bonding-group 4
    upstream 0
    upstream 2
    attributes 80000000
cable upstream bonding-group 5
    attributes 80000000
cable bundle 1
no cable mtc-mode
cable privacy accept-self-signed-certificate
end
!
interface Integrated-Cable9/0/1:0
cable bundle 1
cable rf-bandwidth-percent 65
!
interface Wideband-Cable9/0/1:0
cable bundle 1
cable privacy accept-self-signed-certificate
cable rf-channels channel-list 0-3 bandwidth-percent 20
!
interface Integrated-Cable9/0/1:1
cable bundle 1
cable rf-bandwidth-percent 65
!
interface Wideband-Cable9/0/1:1
cable bundle 1
cable privacy accept-self-signed-certificate
cable rf-channels channel-list 32-35 bandwidth-percent 20
!
!
interface Wideband-Cable9/0/1:60
cable ds-resiliency
!
interface Wideband-Cable9/0/1:61
cable ds-resiliency
!
interface Wideband-Cable9/0/1:62
cable ds-resiliency
!

```

The following is a sample output for the **show cable modem** command to display impaired cable modems below the resiliency threshold value:

```
Router# show cable modem
```

```
MAC Address      IP Address      I/F            MAC            Prim  RxPwr  Timing Num I
```

				State	Sid	(dBmv)	Offset	CPE	P
e448.c70c.96d5	80.17.150.6	C9/0/1/U2		p-online	1	0.00	1784	0	N
e448.c70c.96f3	80.17.150.14	C9/0/1/U1		w-online	2	-1.00	1797	0	N
68ee.9633.0699	80.17.150.31	C9/0/1/U0		w-online	3	-1.00	2088	1	N
e448.c70c.96e7	80.17.150.29	C9/0/1/U3		p-online	4	-0.50	1785	0	N
e448.c70c.982b	80.17.150.18	C9/0/1/U2		w-online	5	0.00	1780	0	N
e448.c70c.9804	80.17.150.13	C9/0/1/U3		w-online	6	-0.50	1788	0	N
e448.c70c.9819	80.17.150.30	C9/0/1/U0		w-online	7	-1.00	1782	0	N
e448.c70c.980d	80.17.150.17	C9/0/1/U0		w-online	8	-1.00	1787	0	N



**Note** p-online indicates that the cable modem has reported NP RF failure and it is in downstream partial service mode.

The following is a sample output when RBGs are created:

Router# **show cable resiliency**

Resil BG I/F	BG ID	Resil BG State	Count	Time	RF Ctrl	Num
Wi9/0/1:60	28989	Assigned	1	Jan 9 07:35:08	1	0
						1
						2
Wi9/0/1:61	28990	Assigned	1	Jan 9 07:36:54	1	0
						1
						3
Wi9/0/1:62	28991	Free	0			

The following is a sample output when cable modems service flows are assigned to RBGs:

Router# **show cable modem resiliency**

I/F	MAC Address	ID	Orig BG I/F	RFs ID	Curr BG I/F	RFs
C9/0/1	e448.c70c.96d5	28929	Wi9/0/1:0	4	28989 Wi9/0/1:60	3
C9/0/1	e448.c70c.96e7	28929	Wi9/0/1:0	4	28990 Wi9/0/1:61	3

The following is a sample output of the **show cable modem** command when the impaired cable modems have recovered:

Router# **show cable modem**

MAC Address	IP Address	I/F	MAC State	Prim Sid	RxPwr (dBmv)	Timing Offset	Num CPE	I P
e448.c70c.96d5	80.17.150.6	C9/0/1/U2	w-online	1	0.00	1784	0	N
e448.c70c.96f3	80.17.150.14	C9/0/1/U1	w-online	2	-1.00	1797	0	N
68ee.9633.0699	80.17.150.31	C9/0/1/U0	w-online	3	-1.00	2088	1	N
e448.c70c.96e7	80.17.150.29	C9/0/1/U3	w-online	4	-0.50	1785	0	N
e448.c70c.982b	80.17.150.18	C9/0/1/U2	w-online	5	0.00	1780	0	N
e448.c70c.9804	80.17.150.13	C9/0/1/U3	w-online	6	-0.50	1788	0	N
e448.c70c.9819	80.17.150.30	C9/0/1/U0	w-online	7	-1.00	1782	0	N
e448.c70c.980d	80.17.150.17	C9/0/1/U0	w-online	8	-1.00	1787	0	N

The following is a sample output of the **show cable resiliency** command when the impaired cable modems have recovered:

```

Router# show cable resiliency

          BG      Resil BG
Resil BG I/F  ID      State      Count Time          RF
-----
Wi9/0/1:60   28989 Free      1      Jan 9 07:35:08
Wi9/0/1:61   28990 Free      1      Jan 9 07:36:54
Wi9/0/1:62   28991 Free      0

```

## Excluding Cable Modems from Downstream Resiliency Operations

Table 70: Feature History

Feature Name	Release Information	Feature Description
Excluding Cable Modems from Downstream Resiliency Operations	Cisco IOS XE Dublin 17.12.1x	<p>You can now exclude cable modems from Downstream Resiliency operations and move them to an exclusion list using the <b>cable resiliency exclude</b> command. Excluding cable modems ensures that RBG and NB are not used and the resiliency activity reduces. The exclusion list is stored on the SUP and you can use the <b>show cable resiliency exclude</b> to view the exclusion list.</p> <p>By excluding cable modems, you can manage the downstream resiliency feature better and improve CPU efficiency. The following scenarios are examples of when you can use this feature and exclude cable modems from Downstream Resiliency operations.</p> <ul style="list-style-type: none"> <li>• Cable modems that report an excessive amount of impairment or recovery events, can be moved to the exclusion list. You can use the <b>show cable resiliency counts</b> command introduced in Cisco IOS XE Dublin 17.12.1x to identify which downstream channels and cable modems have the most impairments.</li> <li>• During planned maintenance windows, cable modems can be moved to the exclusion list.</li> </ul>



### Note

- When adding cable modems to the exclusion list, if a cable modem is on RBG or NB, ensure that you keep it on RBG or NB unless the recovery `cm-status` event is received from the cable modem.
- If you add a cable modem to the exclusion list and later physically disconnect the same cable modem, then ensure that you remove this cable modem from the exclusion list.

For cable modems in the exclusion list the Downstream resiliency behavior is as follows:

- There is no action that is performed for `cm-status` impaired events. The cable modems remain in the `w-online` state with impairment.
- Recovery `cm-status` events are handled as usual.

See:

- [cable resiliency exclude](#)
- [show cable resiliency exclude](#)
- [show cable resiliency counts](#)

## Additional References

### Related Documents

Related Topic	Document Title
Cisco CMTS Command Reference	<a href="http://www.cisco.com/c/en/us/td/docs/cable/cmts/cmd_ref/b_cmts_cable_cmd_ref.htm">http://www.cisco.com/c/en/us/td/docs/cable/cmts/cmd_ref/b_cmts_cable_cmd_ref.htm</a>

### Technical Assistance

Description	Link
The Cisco Support and Documentation website provides online resources to download documentation, software, and tools. Use these resources to install and configure the software and to troubleshoot and resolve technical issues with Cisco products and technologies. Access to most tools on the Cisco Support and Documentation website requires a Cisco.com user ID and password.	<a href="http://www.cisco.com/cisco/web/support/index.html">http://www.cisco.com/cisco/web/support/index.html</a>

## Feature Information for Downstream Resiliency Bonding Group

Use Cisco Feature Navigator to find information about the platform support and software image support. Cisco Feature Navigator enables you to determine which software images support a specific software release, feature set, or platform. To access Cisco Feature Navigator, go to the <https://cfng.cisco.com/> link. An account on the Cisco.com page is not required.



**Note** The following table lists the software release in which a given feature is introduced. Unless noted otherwise, subsequent releases of that software release train also support that feature.

*Table 71: Feature Information for Downstream Resiliency Bonding Group*

<b>Feature Name</b>	<b>Releases</b>	<b>Feature Information</b>
Downstream Resiliency Bonding Group	Cisco IOS XE Fuji 16.7.1	This feature was integrated on the Cisco cBR Series Converged Broadband Routers.
Resiliency Bonding Group Enhancement	Cisco IOS XE Gibraltar 16.12.1y	This feature was integrated on the Cisco cBR Series Converged Broadband Routers.







## CHAPTER 22

# Downstream Channel ID Assignment

**First Published:** April 17, 2015

The DOCSIS downstream channel ID (DCID) is defined as an 8-bit identifier for recognizing a Downstream Channel within a MAC Domain. All CMTS downstream channels are assigned a DCID by default that may be subsequently changed by configuration. It is used in most DOCSIS downstream packet headers and its valid range is from 1 to 255 (0 is reserved for network management purposes).



---

**Note** All downstream channels in a MAC domain must have a unique DCID within the MAC domain.

---

Your software release may not support all the features that are documented in this module. For the latest feature information and caveats, see the release notes for your platform and software release. The Feature Information Table at the end of this document provides information about the documented features and lists the releases in which each feature is supported.

Use Cisco Feature Navigator to find information about platform support and Cisco software image support. To access Cisco Feature Navigator, go to <http://tools.cisco.com/ITDIT/CFN/>. An account on <http://www.cisco.com/> is not required.

### Contents

- [Hardware Compatibility Matrix for the Cisco cBR Series Routers, on page 381](#)
- [Information About Downstream Channel ID Assignment on the Cisco CMTS Routers, on page 383](#)
- [How to Configure Downstream Channel ID Assignment on the Cisco CMTS Routers, on page 385](#)
- [Additional References, on page 389](#)
- [Feature Information for Downstream Channel ID Assignment, on page 389](#)

## Hardware Compatibility Matrix for the Cisco cBR Series Routers



---

**Note** The hardware components that are introduced in a given Cisco IOS-XE Release are supported in all subsequent releases unless otherwise specified.

---

Table 72: Hardware Compatibility Matrix for the Cisco cBR Series Routers

Cisco CMTS Platform	Processor Engine	Interface Cards
Cisco cBR-8 Converged Broadband Router	<p><b>Cisco IOS-XE Release 16.5.1 and Later Releases</b></p> <p>Cisco cBR-8 Supervisor:</p> <ul style="list-style-type: none"> <li>• PID—CBR-SUP-250G</li> <li>• PID—CBR-CCAP-SUP-160G</li> </ul>	<p><b>Cisco IOS-XE Release 16.5.1 and Later Releases</b></p> <p>Cisco cBR-8 CCAP Line Cards:</p> <ul style="list-style-type: none"> <li>• PID—CBR-LC-8D30-16U30</li> <li>• PID—CBR-LC-8D31-16U30</li> <li>• PID—CBR-RF-PIC</li> <li>• PID—CBR-RF-PROT-PIC</li> <li>• PID—CBR-CCAP-LC-40G</li> <li>• PID—CBR-CCAP-LC-40G-R</li> <li>• PID—CBR-CCAP-LC-G2-R</li> <li>• PID—CBR-SUP-8X10G-PIC</li> <li>• PID—CBR-2X100G-PIC</li> </ul> <p>Digital PICs:</p> <ul style="list-style-type: none"> <li>• PID—CBR-DPIC-8X10G</li> <li>• PID—CBR-DPIC-2X100G</li> </ul> <p>Cisco cBR-8 Downstream PHY Module:</p> <ul style="list-style-type: none"> <li>• PID—CBR-D31-DS-MOD</li> </ul> <p>Cisco cBR-8 Upstream PHY Modules:</p> <ul style="list-style-type: none"> <li>• PID—CBR-D31-US-MOD</li> </ul>



**Note** Do not use DPICs (8X10G and 2x100G) to forward IP traffic, as it may cause buffer exhaustion, leading to line card reload.

The only allowed traffic on a DPIC interface is DEPI, UEPI, and GCP traffic from the Cisco cBR-8 router to Remote PHY devices. Other traffic such as DHCP, SSH, and UTSC should flow via another router, since DPICs cannot be used for normal routing.

# Information About Downstream Channel ID Assignment on the Cisco CMTS Routers

These are the downstream channel ID assignment features:

- Unique DCIDs are provided for all channels within a single controller by default.



**Note** DCID values for downstream channels in the same MAC Domain must be unique. If a MAC Domain only contains channels from a single controller, the default DCID values will be sufficient. If a MAC Domain contains channels from multiple controllers, DCID conflicts may be encountered within the MAC Domain. DCID conflicts may be resolved by changing the DCID value of the conflicting channels within the controller configuration or by enabling the automatic channel ID assignment feature.

- The default DCID value for each downstream channel within a controller is equivalent to rf-chan number plus one. For example, the default value for rf-chan 0 is 1, for rf-chan 1 is 2.

## Manual Downstream Channel ID Assignment

When using the manual DCID provisioning feature, every downstream channel in the system is assigned a default DCID value equivalent to (controller QAM id + 1). The table below shows the default DCID ranges per downstream controller.

**Table 73: Default Downstream Channel IDs Per Slot/Subslot/Controller**

	0/0	1/0	2/0	3/0	6/0	7/0	8/0	9/0
DS Controller 0	1-128	1-128	1-128	1-128	1-128	1-128	1-128	1-128
DS Controller 1	1-128	1-128	1-128	1-128	1-128	1-128	1-128	1-128
DS Controller 2	1-128	1-128	1-128	1-128	1-128	1-128	1-128	1-128
DS Controller 3	1-128	1-128	1-128	1-128	1-128	1-128	1-128	1-128
DS Controller 4	1-128	1-128	1-128	1-128	1-128	1-128	1-128	1-128

	0/0	1/0	2/0	3/0	6/0	7/0	8/0	9/0
DS Controller 5	1-128	1-128	1-128	1-128	1-128	1-128	1-128	1-128
DS Controller 6	1-128	1-128	1-128	1-128	1-128	1-128	1-128	1-128
DS Controller 7	1-128	1-128	1-128	1-128	1-128	1-128	1-128	1-128

The default DCID value can be replaced with a user configurable value. The configuration is available in the downstream controller per channel. The current DCID values for the channels within a downstream controller can be viewed in the `dcid` column of the `show controller Integrated-Cable rf-chan` command output. The example shows channels with default DCID values. When a DCID value is changed in the configuration, the new value appears in the output below.

```
Router#show controllers integrated-Cable 3/0/0 rf-channel 1-127
Chan State Admin Frequency Type Annex Mod srate Interleaver dcid power output
1 NPRE UP 99000000 DOCSIS B 256 5361 I32-J4 2 37 NORMAL
2 NPRE UP 105000000 DOCSIS B 256 5361 I32-J4 3 37 NORMAL
3 NPRE UP 111000000 DOCSIS B 256 5361 I32-J4 4 37 NORMAL
4 NPRE UP 117000000 DOCSIS B 256 5361 I32-J4 5 37 NORMAL
5 NPRE UP 123000000 DOCSIS B 256 5361 I32-J4 6 37 NORMAL
6 NPRE UP 129000000 DOCSIS B 256 5361 I32-J4 7 37 NORMAL
7 NPRE UP 135000000 DOCSIS B 256 5361 I32-J4 8 37 NORMAL
8 NPRE UP 141000000 DOCSIS B 256 5361 I32-J4 9 37 NORMAL
9 NPRE UP 147000000 DOCSIS B 256 5361 I32-J4 10 37 NORMAL
10 NPRE UP 153000000 DOCSIS B 256 5361 I32-J4 11 37 NORMAL
11 NPRE UP 159000000 DOCSIS B 256 5361 I32-J4 12 37 NORMAL
12 NPRE UP 165000000 DOCSIS B 256 5361 I32-J4 13 37 NORMAL
13 NPRE UP 171000000 DOCSIS B 256 5361 I32-J4 14 37 NORMAL
14 NPRE UP 177000000 DOCSIS B 256 5361 I32-J4 15 37 NORMAL
15 NPRE UP 183000000 DOCSIS B 256 5361 I32-J4 16 37 NORMAL
```

Router#

## Automatic Downstream Channel ID Assignment on the Cisco CMTS Routers

It is possible to automatically assign a unique set of downstream channel IDs to meet all DOCSIS requirements by enabling the Automatic DCID Assignment feature. When enabled, Downstream channel DCIDs will be automatically assigned when the channels are added to a fiber node and associated with a MAC Domain. Therefore, the use of fiber node configuration is a prerequisite for this feature.

### Service Impact

Changing the DOCSIS downstream channel ID causes cable modems to re-register. Cable modems receive MAC Domain Descriptor (MDD) and Upstream Channel Descriptor (UCD) messages with a changed DCID in their headers.

- Enabling the automatic DCID assignment displays the following message:

WARNING: Enabling automatic DCID assignment will cause modems to flap and will apply to all fiber nodes on this CMTS.

- Disabling the automatic DCID assignment displays the following message:

WARNING: Disabling automatic DCID assignment will no longer enforce channel-id uniqueness at fiber nodes. Channel ID changes may require manual verification to prevent conflicts.

- If there is a DCID conflict with another channel in the MAC Domain, the following error message is displayed:

```
ERROR: <slot>/<subslot>/<controller> rf-channel <channel>: The downstream channel id
conflicts with interface In<slot>/<subslot>/<controller>:channel. Downstream channel
id must be unique in a CGD.
```

- After automatic DCID assignment is configured, if there is a DCID conflict when a downstream channel that belongs to a fiber node is added to a MAC Domain, the automatic DCID feature tries to resolve the conflict by assigning another automatic DCID and the following message is displayed:

```
WARNING: The downstream channel id conflict for <slot>/<subslot>/<controller> rf-channel
<channel> was resolved by Automatic DCID Assignment.
Please run "interface <md-slot>/<md-subslot>/<md-index>" followed by
"<slot>/<subslot>/<controller> rf-channel <channel>" again in order to add the channel.
```

To add the channel, use this channel grouping domain (CGD) command again:

```
cable downstream x/y/z rf-channel channel
```

- If automatic DCID is configured and the channel does not belong to a fiber node, or if automatic DCID cannot resolve the conflict, the following message is displayed:

```
WARNING: The downstream channel id conflict for <slot>/<subslot>/<controller> rf-channel
<channel> could not be resolved by Automatic DCID Assignment.
```

To resolve this issue, add the channel to a fiber node.

## How to Configure Downstream Channel ID Assignment on the Cisco CMTS Routers

The following sections describe how to configure downstream channel ID assignment.

### Configuring Manual Downstream Channel ID Assignment

#### Procedure

	Command or Action	Purpose
Step 1	enable  Example:	Enables privileged EXEC mode.  Enter your password if prompted.

	Command or Action	Purpose
	Router> <b>enable</b>	
<b>Step 2</b>	<b>configure terminal</b>  <b>Example:</b> Router# <b>configure terminal</b>	Enters global configuration mode.
<b>Step 3</b>	<b>interface controller integrated-Cable slot/subslot/port</b>  <b>Example:</b> Router(config)# <b>interface controller integrated-Cable 1/0/1</b>	Enters controller configuration mode for the Channel Grouping Domain host line card.
<b>Step 4</b>	<b>rf-chan downstream QAM ID</b>  • Alternatively, use the <b>rf-chan starting downstream QAM ID ending downstream QAM ID</b> command to set the range of downstream channel IDs.  <b>Example:</b> Router(config-controller)# <b>rf-chan 0</b>	Enters the rf-channel configuration mode.
<b>Step 5</b>	<b>docsis-channel-id DCID</b>  <b>Example:</b> Router(config-rf-chan)# <b>docsis-channel-id 1</b>	Configures the downstream channel's DCID to the specified value, for the RF channel.  For the rf-channel range that was configured using the <b>rf-chan starting downstream QAM ID ending downstream QAM ID</b> command, the <b>docsis-channel-id DCID</b> command configures the DCIDs for the rf-channels in that range.

## Configuring Automatic Downstream Channel ID Assignment

Automatic DCID assignment should be permanently configured. However, if you need to remove the feature, use the **no** or **default** commands.



**Note** The **no** or **default** form of the command is not written to startup-config file.

In this case, the DCIDs are retained as computed for all channels, and are not set to the defaults of the channels. Save the configuration containing the newly-assigned DCIDs to the startup-config file by using the **write memory** command.

When you enable automatic DCID assignment, any DCID conflict arising due to adding a channel to a MAC Domain is resolved automatically.



**Restriction**

- After running the **cable downstream-channel-id automatic** command in the configuration, manually editing the configuration file in an editor to add RF channels to the fiber nodes could cause DCID conflicts. The feature assumes all channels in fiber nodes have unique automatic DCIDs in global configuration mode. If the configuration is manually edited and the feature does not verify the unique DCIDs, the DCIDs of the newly-added channels may conflict with those of the existing channels. To fix any DCID conflicts, undo and re-apply the global automatic DCID configuration.



**Note**

Re-applying global automatic DCID configuration is a disruptive operation.

To avoid DCID conflicts, edit the configuration to configure the fiber nodes, then run the **cable downstream-channel-id automatic** command so all channels have unique automatic DCIDs.

Make additions to the fiber nodes on the Cisco uBR10012 router command line interface with the automatic DCID configured.

- The **cable downstream-channel-id automatic** command should not be manually edited in to the startup-config file, since it does not guarantee unique DCIDs for channels in the fiber node.

**Procedure**

	Command or Action	Purpose
Step 1	<b>enable</b> <b>Example:</b> Router> <b>enable</b>	Enables privileged EXEC mode. <ul style="list-style-type: none"> <li>• Enter your password if prompted.</li> </ul>
Step 2	<b>configure terminal</b> <b>Example:</b> Router# <b>configure terminal</b>	Enters global configuration mode.
Step 3	<b>cable downstream-channel-id automatic</b> <b>Example:</b> Router(config)# <b>cable downstream-channel-id automatic</b>	Specifies automatic assignment of the DCIDs by the Cisco CMTS.

**Example**

This example displays the restriction on manually editing configurations:

```

Router# show run | include automatic
cable downstream-channel-id automatic

router# show cable fiber-node 3
-----
Fiber-Node 3
Channel(s) : downstream Integrated-Cable 1/0/2: 0-3, 32-35, 64-67, 96-99
Channel ID(s): 1 2 3 4 33 34 35 36 65 66 67 68 97 98 99 100
    
```

```
Upstream-Cable 1/0/2
FN Config Status: Configured (status flags = 0x01)
MDD Status: Valid
Router#
```

If you manually edit the startup-config file in an editor to add a downstream controller, for example, 1/0/3, it causes a conflict.

```
Router> configure terminal
Router# cable fiber-node 3
Router# downstream integrated-Cable 1/0/3
```

If this downstream controller is added, the automatic DCID assignment feature automatically resolves it. However, since the startup-config file was manually edited to add the downstream controller, the automatic DCID assignment feature is unable to resolve it. This causes a DCID conflict when the edited startup-config file is loaded and invalidates the fiber node.

```
down Modular-Cable 5/0/0 rf-channel 0
DS frequency is not unique.
DS channel id is not unique.
Warning: D3.0 CMs cannot get w-online with an invalid fiber-node.
router#
```

### What to do next

Run the **show cable fibernode** command to view DCIDs assigned to all the channels in the fiber node.

```
Router# show cable fiber-node 3
Fiber-Node 3
Channel(s) : downstream Integrated-Cable 1/0/2: 0-3, 32-35, 64-67,
96-99
Channel ID(s): 1 2 3 4 33 34 35 36 65 66 67 68 97 98
99 100
Upstream-Cable 1/0/2
FN Config Status: Configured (status flags = 0x01)
MDD Status: Valid
```



## Additional References

### Technical Assistance

Description	Link
<p>The Cisco Support website provides extensive online resources, including documentation and tools for troubleshooting and resolving technical issues with Cisco products and technologies.</p> <p>To receive security and technical information about your products, you can subscribe to various services, such as the Product Alert Tool (accessed from Field Notices), the Cisco Technical Services Newsletter, and Really Simple Syndication (RSS) Feeds.</p> <p>Access to most tools on the Cisco Support website requires a Cisco.com user ID and password.</p>	<a href="http://www.cisco.com/cisco/web/support/index.html">http://www.cisco.com/cisco/web/support/index.html</a>

## Feature Information for Downstream Channel ID Assignment

Use Cisco Feature Navigator to find information about the platform support and software image support. Cisco Feature Navigator enables you to determine which software images support a specific software release, feature set, or platform. To access Cisco Feature Navigator, go to the <https://cfmng.cisco.com/> link. An account on the Cisco.com page is not required.



**Note** The following table lists the software release in which a given feature is introduced. Unless noted otherwise, subsequent releases of that software release train also support that feature.

**Table 74: Feature Information for Downstream Channel ID Assignment**

Feature Name	Releases	Feature Information
Downstream Channel ID Assignment	Cisco IOS XE Fuji 16.7.1	This feature was integrated on the Cisco cBR Series Converged Broadband Router.





## CHAPTER 23

# Upstream Channel Bonding

The Upstream Channel Bonding (USCB) feature helps cable operators offer higher upstream (US) bandwidth per cable modem (CM) user by combining multiple radio frequency (RF) channels to form a larger bonding group at the MAC layer.

Your software release may not support all the features that are documented in this module. For the latest feature information and caveats, see the release notes for your platform and software release. The Feature Information Table at the end of this document provides information about the documented features and lists the releases in which each feature is supported.

Use Cisco Feature Navigator to find information about platform support and Cisco software image support. To access Cisco Feature Navigator, go to <http://tools.cisco.com/ITDIT/CFN/>. An account on <http://www.cisco.com/> is not required.

### Contents

- [Hardware Compatibility Matrix for the Cisco cBR Series Routers](#), on page 391
- [Prerequisites for Upstream Channel Bonding](#), on page 393
- [Restrictions for Upstream Channel Bonding](#), on page 393
- [Information About Upstream Channel Bonding](#), on page 395
- [How to Configure Upstream Channel Bonding](#), on page 404
- [Configuration Example for Upstream Channel Bonding](#), on page 420
- [Verifying the Upstream Channel Bonding Configuration](#), on page 422
- [Additional References](#), on page 423
- [Feature Information for Upstream Channel Bonding](#), on page 423

## Hardware Compatibility Matrix for the Cisco cBR Series Routers



---

**Note** The hardware components that are introduced in a given Cisco IOS-XE Release are supported in all subsequent releases unless otherwise specified.

---

Table 75: Hardware Compatibility Matrix for the Cisco cBR Series Routers

Cisco CMTS Platform	Processor Engine	Interface Cards
Cisco cBR-8 Converged Broadband Router	<p><b>Cisco IOS-XE Release 16.5.1 and Later Releases</b></p> <p>Cisco cBR-8 Supervisor:</p> <ul style="list-style-type: none"> <li>• PID—CBR-SUP-250G</li> <li>• PID—CBR-CCAP-SUP-160G</li> </ul>	<p><b>Cisco IOS-XE Release 16.5.1 and Later Releases</b></p> <p>Cisco cBR-8 CCAP Line Cards:</p> <ul style="list-style-type: none"> <li>• PID—CBR-LC-8D30-16U30</li> <li>• PID—CBR-LC-8D31-16U30</li> <li>• PID—CBR-RF-PIC</li> <li>• PID—CBR-RF-PROT-PIC</li> <li>• PID—CBR-CCAP-LC-40G</li> <li>• PID—CBR-CCAP-LC-40G-R</li> <li>• PID—CBR-CCAP-LC-G2-R</li> <li>• PID—CBR-SUP-8X10G-PIC</li> <li>• PID—CBR-2X100G-PIC</li> </ul> <p>Digital PICs:</p> <ul style="list-style-type: none"> <li>• PID—CBR-DPIC-8X10G</li> <li>• PID—CBR-DPIC-2X100G</li> </ul> <p>Cisco cBR-8 Downstream PHY Module:</p> <ul style="list-style-type: none"> <li>• PID—CBR-D31-DS-MOD</li> </ul> <p>Cisco cBR-8 Upstream PHY Modules:</p> <ul style="list-style-type: none"> <li>• PID—CBR-D31-US-MOD</li> </ul>



**Note** Do not use DPICs (8X10G and 2x100G) to forward IP traffic, as it may cause buffer exhaustion, leading to line card reload.

The only allowed traffic on a DPIC interface is DEPI, UEPI, and GCP traffic from the Cisco cBR-8 router to Remote PHY devices. Other traffic such as DHCP, SSH, and UTSC should flow via another router, since DPICs cannot be used for normal routing.

## Prerequisites for Upstream Channel Bonding

- Enable downstream channel bonding before configuring the Upstream Channel Bonding feature on a Cisco cable modem termination system (CMTS) router.
- Ensure that the CM is registered in Multiple Receive Channel (MRC) mode before configuring upstream channel bonding on a Cisco CMTS router.
- Ensure that the CM is DOCSIS 3.0 certified.

## Restrictions for Upstream Channel Bonding

The following are the general restrictions for the Upstream Channel Bonding feature:

- Only the static bonding groups are supported.
- Committed information rate (CIR) oversubscription is not supported on USCB groups.

Cisco CMTS allows oversubscription of the available bandwidth for individual upstream channels. However, oversubscription of bandwidth is not supported for USCB groups.

An individual upstream may get oversubscribed due to static CIR service flows created for voice traffic. This may cause the DOCSIS 3.0 CMs with USCB to come online on a single channel US bonding group (also known as default bonding group).

This problem is encountered in the voice deployments using static service flows. It is, therefore, recommended to choose from the following voice deployments such that the CIR is allocated (or released) when a voice call is attempted (or dropped):

1. Dynamic Quality of Service (DQoS) Lite
2. Packet Cable (PC) DQoS
3. Packet Cable Multimedia (PCMM)

These deployments avoid the individual upstream oversubscription and CMs come online on expected bonding groups.

- Only the upstream channels belonging to the same MAC domain can be added to an upstream bonding group.



---

**Note** A maximum of 16 upstream channels can be configured for each MAC Domain, which are divided into two groups:

- **Group 1:** upstream channel 0–7
  - **Group 2:** upstream channel 8–15
-

Table 76: Feature History

Feature Name	Release Information	Feature Description
Configuring 10 Channels in Upstream Bonding Group (USBG)	Cisco IOS XE Dublin 17.12.1w	<p>In this release, you can configure up to 10 channels (8 ATDMA and 2 OFDMA) for USBG. In addition to TLV 47, TLV 89 is also supported. Configuring 10 channels allows you to optimally use the spectrum in USBG.</p> <p>In previous releases, you can only configure up to 8 channels.</p>
Upstream Bonding Group Enhancements	Cisco IOS XE Cupertino 17.9.1y	<p>Starting with Cisco IOS XE Cupertino 17.9.1y the <code>upstream bonding-group</code> (USBG) can include any of the available 16 US channels. You can arbitrarily configure a combination of US channels in a USBG. The maximum limit remains eight channels per USBG. For example, you can configure US6, US7, US8, and US9 together in a USBG.</p> <p>In releases before Cisco IOS XE Cupertino 17.9.1y, the <code>upstream bonding-group</code> can only include upstream channels either from <b>Group 1</b> (US channels.0-7) or <b>Group 2</b> (US channels. 8–15) For example, you can't configure US6, US7, US8, and US9 together in a USBG as they are from different groups.</p>

**Note**

- Starting with Cisco IOS XE Dublin 17.12.1w, you can configure up to 10 (8 ATDMA and 2 OFDMA) upstream channels in an **upstream bonding-group**.

- In legacy configurations, if you try to configure more than 8 ATDMA or more than 2 OFDMA channels then you get the following error message depending on the configuration:

**Table 77: Error Messages for Legacy Configurations**

Configuration	Error Message
Configure more than 8 ATDMA channels in a USBG	Error: Maximum Limit of USBG ATDMA channels count of 8 reached
Configure more than 2 OFDMA channels in a USBG	Error: Maximum Limit of USBG OFDMA channels count of 2 reached

- In OPS configuration if you configure more than 10 us channels in a USBG then you get the following error message:

**Table 78: Error Messages for OPS Configurations**

Configuration	Error Message
Configure more than 10 us channels in a USBG	Only allow at most 10 us channels in an USBG

In these 10 us channels, if you configure more than 8 ATDMA or more than 2 OFDMA channels then fiber-node binding fails. In the debug logs you get the appropriate error message.

- In releases before Cisco IOS XE Dublin 17.12.1w, you get the following error message if you attempt to configure more than 8 upstream channels in a **upstream bonding-group**:

Only allow at most 8 us channels in an USBG

**Table 79: Error Messages for OPS and Legacy Configurations (Before Cisco IOS XE Dublin 17.12.1w)**

Configuration	Error Message
Configure more than 8 US channels in a USBG	Only allow at most 8 us channels in an USBG

## Information About Upstream Channel Bonding

DOCSIS 3.0-based upstream channel bonding is a method for increasing upstream bandwidth up to a maximum of 120 Mbps raw throughput per CM user in a cable communications system that includes a Cisco CMTS router and multiple CMs. The upstream channel bonding method enables a CM to transmit data to a Cisco CMTS router on multiple upstream channels simultaneously.

Channel bonding is a method by which smaller bandwidth upstream channels are bonded together to create a larger upstream bonding group in the MAC domain. A MAC domain is a logical sub-component of a Cisco

CMTS router and is responsible for implementing all DOCSIS functions on a set of downstream and upstream channels.

The Upstream Channel Bonding feature supports upstream traffic in Multiple Transmit Channel (MTC) mode for data and video services as these services require more bandwidth than voice-based services. Voice-based services either use the traditional single upstream channel or a single upstream channel bonding group configuration. Any traffic contract that exceeds 30 Mbps requires upstream channel bonding as the physical capacity of a single RF channel in DOCSIS cannot exceed 30 Mbps.

The Upstream Channel Bonding feature is supported on the Cisco cBR-8 router. Upstream data from the subscriber comes through the upstream ports (US0-US19) that are automatically configured on the cable interface line card. The cable interface line card processes the data and sends it across the backplane to the WAN card and out to the Internet.

The table below lists the downstream and upstream frequency supported on the cable interface line card.

*Table 80: Downstream and Upstream Frequency*

Line Card	Downstream Frequency	Upstream Frequency
Cisco cBR-8 CCAP	55-999 MHz <sup>1</sup>	The upstream frequency range for the Cisco cBR-8 CCAP line card is from 5 to 85 MHz irrespective of the region and Annexure configuration.

<sup>1</sup> This frequency range is subjected to the frequency restriction of the attached EQAM device.

## Multiple Transmit Channel Mode

Multiple Transmit Channel mode is a CM capability that enables CMs to send upstream traffic on multiple upstream channels. You can enable the MTC mode on a cable interface line card:

- MTC mode for all CMs in a MAC domain—The MTC mode for all CMs in a MAC domain is enabled by default on an upstream bonding capable cable interface line card.

## Multiple Receive Channel Mode

MRC mode is a CM capability that enables CMs to receive downstream traffic on multiple downstream channels. The MRC mode is enabled by default on an upstream bonding capable cable interface line card. You can enable or disable the MRC mode in the MAC domain during or after the CM registration using the `cable mrc-mode` command.

## Dynamic Range Window and Transmit Power Levels for Upstream Channel Bonding

The dynamic range window functionality is based on the CableLabs DOCSIS 3.0 MAC and Upper Layer Protocols Interface Specification and DOCSIS 3.0 Specification. This requires a DOCSIS 3.0 CM to have upstream transmit channel power level within a 12 dB range for all channels in its transmit channel set (TCS).

DOCSIS 1.x or 2.0 CMs operating with a single upstream channel, in non-MTC mode, have a higher maximum transmit power level than DOCSIS 3.0 CMs operating in the MTC mode with two or more upstream channels. That is, the maximum transmit power level per channel is reduced in the MTC mode.



When the upstream attenuation exceeds the maximum transmit power level, a DOCSIS 3.0 CM attempting to register in the MTC mode may fail to come online, or register in partial mode. The CM fails to register when the transmit power level of all upstream channels in its TCS exceeds the maximum transmit power level. If the CM has some upstream channels that are within the maximum transmit power level, the CM may come online in partial mode. However, the upstream channels that exceed the maximum transmit power level are marked as down and cannot be used for upstream traffic.

To verify the transmit power levels on a CM, use the `show cable modem` command with the `verbose` keyword. This command displays the following transmit power values for each assigned upstream channel:

- **Reported Transmit Power**—This is the reported transmit power level by the CM for each upstream channel.
- **Minimum Transmit Power**—This is the minimum transmit power level that the CM in the MTC mode could transmit at for the upstream channel.
- **Peak Transmit Power**—This is the maximum transmit power level that the CM in the MTC mode could transmit at for the upstream channel.

To support upstream channel bonding, the minimum transmit power must be less than or equal to the reported transmit power, and the reported transmit power must be less than or equal to the peak transmit power. The peak transmit power and minimum transmit power levels are derived from the CM TCS assignment and each individual upstream channel configuration.

If the minimum transmit power is higher than the reported transmit power, or the reported transmit power is higher than the peak transmit power, the CM may not come online or may register in partial mode.

You can troubleshoot this transmit power problem in the following two ways:

- Insert an additional amplifier to reduce the upstream attenuation so that the upstream transmit power falls within the allowed transmit power range (12 dB).
- Disable the MTC mode. To switch the CM from the MTC mode to non-MTC mode, disable the bonded-bit (bit-0) in type, length, value (TLV) 43.9.3 using the CM configuration file.

## Extended Transmit Power

During the early deployment of DOCSIS 3.0 CMs, additional power is required from the CMs in order to compensate for the attenuation in the upstream path. CMs should transmit at extended power level than that defined in DOCSIS. This scenario is generally observed when USCB is enabled at the Cisco CMTS and the DOCSIS 3.0 CMs are operating in MTC mode.

Additional upstream power provides the operator with a power margin that helps overcome the upstream signal loss, reduces the cable plant operational cost, and enables rapid deployment of DOCSIS 3.0 CMs.

The Cisco CMTS supports the following features with which the CMs can transmit data at an extended power:

- Cisco Extended Transmit Power Feature
- DOCSIS Extended Transmit Power Feature

### Cisco Extended Transmit Power Feature

The Cisco Extended Transmit Power feature supports DOCSIS 3.0 CMs operating in MTC mode to transmit at a higher power level than the power level specified in the *DOCSIS 3.0 Specification*. This feature is supported only with Cisco DPC3000 CMs.

The Cisco Extended Transmit Power feature enables cable operators to have better control on the cable modems that register in 4-channel or 2-channel MTC mode or in non-MTC mode to transmit at a higher power level

than the DOCSIS-defined maximum power level. The cable operator can configure extended transmit power using the **cable tx-power-headroom** command in global configuration mode.

### DOCSIS Extended Transmit Power Feature

The DOCSIS Extended Transmit Power feature supports extended upstream transmit power capability as defined in the DOCSIS3.0 Specification. This feature allows the CMs to transmit at a high extended power level to counter the attenuation in the US channel.

The table below lists the new TLVs supported by the DOCSIS Extended Transmit Power feature.

**Table 81: TLVs for DOCSIS Extended Power Feature**

TLV Name	Type	Length	Value
Extended Upstream Transmit Power Support	16	1	0—Extended Upstream Transmit Power Support Off 1—Extended Upstream Transmit Power Support On 2-255—Reserved
Extended Upstream Transmit Power CM Capability	5.40	1	0, 205-244 (units of one-quarter dB)

The Cisco CMTS sends TLV16 to inform the CM if the DOCSIS Extended Transmit Power feature is enabled. The CM in turn, sends TLV5.40 to the Cisco CMTS to communicate its extended power capability. After the negotiations are complete, the CM can transmit at an extended power.

DOCSIS Extended Transmit Power feature is enabled by default. Use the cable upstream ext-power command to enable or disable this feature. For more information on how to enable or disable DOCSIS Extended Power feature, see [Configuring DOCSIS Extended Transmit Power Feature, on page 419](#).



**Note** DOCSIS Extended Transmit Power feature takes precedence, if both Cisco Extended Transmit Power feature and DOCSIS Extended Transmit Power feature are configured.

## Reduced Transmit Channel Set

The Reduced Transmit Channel Set feature enables the Cisco CMTS router to reduce upstream channel set assignment based on the total power budget of the CM. For example, a reduction from four to two upstream channels gains 3 dB headroom. Further reduction from two channels to a single channel gains another 3 dB headroom, and the CM starts operating in non-MTC mode.

In order to take advantage of the reduced upstream channel set, the corresponding static bonding groups must be configured. For example, a MAC domain is configured with a bonding group having four channels. A CM with the reduced channel set of two is unable to match to the 4-channel bonding group, and can only be matched to a bonding group with two channels or less.

The Reduced Transmit Channel Set feature is helpful when a DOCSIS 3.0 CM is required to increase its total transmit power by 3 dB. For example, a DOCSIS 1.0 or 2.0 CM supports a maximum transmit power of 58 dBmV for Quadrature Phase Shift Keying (QPSK) modulation, while a DOCSIS 3.0 CM supports a maximum transmit power of 61 dBmV. In this case, the DOCSIS 3.0 CM operating in 4-channel MTC mode has a

reduction in the maximum transmit power per upstream channel. This feature enables the Cisco CMTS router to support reduced input power level by 6 dB to prevent upstream path attenuation.

## T4 Multiplier

T4 multiplier is the T4 timeout multiplier value of the default T4 timeout values as defined in for cable modems that are in the MTC mode. The default value is derived from the number of channels in the modem transmit channel set. You can change the default T4 multiplier value using the cable upstream ranging-poll command in cable interface configuration mode.

The T4 timeout multiplier values range is from 1 to 10. If the T4 multiplier value is equal to 1, the cable modem will T4 time out in 30 seconds (that is,  $1 \times 30 = 30$ ). If you change the T4 multiplier to 4, then the new T4 timeout value will be 120 seconds (that is,  $4 \times 30 = 120$ ).



**Note** If the T4 timeout multiplier is not configured from the range (1 - 10), then the CMTS uses the T4 timeout value of modem as T4 timeout value. For example, if the T4 timeout of the modem is 90 seconds, then the CMTS applies 3 as the T4 multiplier.

In the MTC mode, you can increase the T4 timeout value in order to reduce the router overhead associated with processing of ranging request (RNG-REQ) slots and ranging response messages. If an RNG-RSP message does not contain a T4 timeout multiplier value, then the CM uses the default T4 timeout value.

## Fiber Node Configuration for Upstream Channel Bonding

The fiber node configuration on a Cisco CMTS router is used to define MAC domain downstream service groups (MD-DS-SGs) and MAC domain upstream service groups (MD-US-SGs) as defined in DOCSIS 3.0. Only the DOCSIS 3.0 certified modems use this information.

In hybrid fiber coaxial (HFC) networks, all CMs connected to the same coaxial segment of a fiber node reach the same set of downstream and upstream channels on one or more Cisco CMTS routers located at the headend.

A CM is physically connected to only one fiber node. The fiber node must include at least one primary-capable controller for the CM connected to the fiber node to be operational.

## New TLVs for Upstream Channel Bonding

The table below lists the new CableLabs defined type, length, values (TLVs) for the Upstream Channel Bonding feature.

**Table 82: New TLVs for Upstream Channel Bonding**

TLV Name	Type	Length	Value
CM vendor ID	43.8	3	Per vendor definition
Cable modem attribute mask	43.9	n	Cable modem attribute mask subtype encodings

A Cisco CMTS can have multiple upstream channel bonding groups (USBG) configured. Each of these bonding groups can include upstream channels with different upstream frequencies. Some bonding groups can include channels with frequencies within the extended frequency range (see [Table 80: Downstream and](#)

[Upstream Frequency, on page 396](#)). An HFC network consists of several types of CMs, each supporting standard or extended upstream frequencies.

When you register a CM, the Cisco CMTS does not assign bonding groups based on the upstream frequency range that is supported by that CM. The assignment of the bonding groups is done to balance the CM count on each of the bonding groups. This may lead to assignment of a bonding group, in the extended frequency range, to a CM that lacks the extended frequency support. As a result, the CM will not be able to register. This scenario is generally observed in the Cisco cBR-8 CCAP line card deployment (containing a mix of CMs), which supports frequency as high as 85MHz (see [Table 80: Downstream and Upstream Frequency, on page 396](#)).

If the Cisco CMTS assigns a USBG with a channel within the extended frequency range to a CM limited to the standard frequency range, that CM may not be able to register on that upstream bonding group. Use the TLV 43.9.3 (CM US Required Attribute Mask) or TLV 43.9.4 (CM US Forbidden Attribute Mask) as a workaround. These TLVs enable the Cisco CMTS to assign CM to a USBG, which is in the upstream frequency range that is supported by that CM.

The default attributes (in hexadecimal) on a CM Attribute Mask (TLV 43.9) are "80 00 00 00", which means by default the mask is all zeroes with the bonding bit enabled. The first four bytes are predefined while the last four bytes are user-defined. In order to enable Cisco CMTS to assign bonding groups based on the frequency range supported by CMs, complete these steps:

1. Configure a mask, using TLV 43.9.3 or TLV 43.9.4, by modifying the last four bytes. The mask should be configured such that a unique attribute is assigned to each of the bonding groups.
2. Apply this mask to the CM configuration file. CMs supporting extended frequency, can register with any USBGs, irrespective of the configured frequency range of the USBG. CMs supporting standard frequency, can only register with USBGs that are configured with the standard frequency range.

Apply the mask that you have configured above, to the CMs that support standard, or extended frequency ranges. However, the ONLY CMs that must employ the attribute mask are the ones with the standard frequency range, since they will not be able to register with the USBG configured with extended upstream frequency range. No attribute mask on the extended frequency supporting CMs means that these modems are assigned to any USBG.

The Cisco CMTS uses this mask, received in the CM configuration file during registration, to decide which USBG should be assigned to the CM.

## TLV 89

In releases before Cisco IOS XE Dublin 17.12.1w, cBR-8 routers use TLV 47 to contain an SFID and channel-to-SID mapping within the SID cluster. For TLV 47, the type and length field are both 1 byte, so the value cannot exceed 255 bytes. If you configure 10 USBG and 2 SID clusters, then TLV 47 length exceeds the max length limit.

Starting with Cisco IOS XE Dublin 17.12.1w, we have added TLV 89 support.

If a modem supports TLV 89, then CMTS has no issue with sending 2 SID clusters with 10 (8+2) US channels. You can view the **Ext SF SID Cluster Assignment** output field in the **show cable modem CM Mac verbose** output, to see whether the modem supports TLV 89. If the output is 0, then the modem doesn't support TLV89. If the output is 1, then the modem supports TLV89. The following example shows a sample output of the **show cable modem CM Mac verbose** command:

```
Router#show cable modem 4458.2945.4584 verbose | i Ext SF
Ext SF SID Cluster Assignment : 0
Router#
```



**Note** With 10 USBG, you also must configure 9 (7+2 or 8+1) USBG, then only modems not supporting TLV89 become online with 9 US channels.

## Upstream Weighted Fair Queuing

The upstream weighted fair queuing (WFQ) is a quality of service (QoS) feature that enables the Cisco CMTS router to allocate optimum bandwidth to upstream service flows based on the WFQ parameter configurations. To enable upstream WFQ, you must configure either the class-based or activity-based WFQ on a cable interface.

The following WFQ parameter configurations are supported:

### Class-Based Weighted Fair Queuing

In the class-based weighted fair queuing configuration, allocation of available bandwidth is dependent on the service flows that are active in a service class. A service class is a group of queuing attributes configured on the Cisco CMTS router. The class must have at least one active service flow. The class receives its portion of the available bandwidth based on the weight of the class. By default, each class (0 to 7) has a weight of “class + 1.” For example, the class 0 has a weight of 1, and class 1 has a weight of 2.

### Activity-Based Weighted Fair Queuing

In the activity-based weighted fair queuing configuration, allocation of available bandwidth is based on the service class and the total number of service flows that are active in a map for the service class. A service class with higher number of service flows receives the larger percentage of bandwidth.

### Custom Weight for Service Flow Priorities

The weighted fair queuing functionality helps the Cisco CMTS router share the available bandwidth based on the weight of the service flow priorities specified for outstanding requests from an upstream service flow. Priority refers to the service flow priority specified in the CM configuration file, or the Cisco CMTS service class configuration. By default, the weight of a priority is equal to “priority+1.” For example, priority 0 has a weight of 1, and priority 1 has a weight of 2. A higher priority provides more weight to the outstanding request. The custom weight can be specified for a total of eight priorities (0 to 7) in a service class.

The priority parameter refers to the priority of traffic in a service flow ranging from 0 (the lowest) to 7 (the highest). In the upstream traffic, all of the pending high priority service flows are scheduled for transmission before low priority service flows. You can configure the weight for priorities based on how much weight is appropriate per priority.

The table below lists the default weight for each service flow priority.

**Table 83: Default Weight of Service Flow Priorities**

Service Flow Priority	Default Weight
0	1
1	2
2	3

Service Flow Priority	Default Weight
3	4
4	5
5	6
6	7
7	8

## Upstream Scheduler and Service Flows

A DOCSIS-qualified Cisco CMTS router can provide varied upstream scheduling modes for different packet streams or applications using upstream service flows. A service flow represents either an upstream or a downstream flow of data. A unique service flow ID (SFID) identifies each service flow. Each service flow can have its own quality of service (QoS) parameters, such as maximum throughput, minimum guaranteed throughput, and priority. In the case of upstream service flows, you can also specify a scheduling mode.

Scheduling is a process that enables the Cisco CMTS router to receive bandwidth requests and grant timeslots to CMs for the upstream traffic. The Cisco CMTS router periodically creates a grant map for each enabled upstream channel. The map grants individual timeslots to enable CMs to place packets on the upstream channels.

DOCSIS 3.0 describes a method by which a CM creates an upstream service flow. The following scheduling types enable the Cisco CMTS router to allocate bandwidth for upstream service flows:

- Unsolicited grant service (UGS)
- Solicited grant service

The unsolicited grant service is primarily used for voice. In the case of UGS, the CM does not have to explicitly request grants from the Cisco CMTS router whereas in the solicited grant service the CM has to explicitly request grants from the Cisco CMTS router. The solicited grant service is primarily used for best effort (BE) services.

Unlike DOCSIS 2.0, DOCSIS 3.0 allows multiple outstanding requests per service flow. For more information about the upstream scheduler, see the *Upstream Scheduler Mode for the Cisco CMTS Routers* feature guide at the following URL:

[http://www.cisco.com/en/US/docs/ios/cable/configuration/guide/cmts\\_upstm\\_sch\\_md\\_ps2209\\_TSD\\_Products\\_Configuration\\_Guide\\_Chapter.html](http://www.cisco.com/en/US/docs/ios/cable/configuration/guide/cmts_upstm_sch_md_ps2209_TSD_Products_Configuration_Guide_Chapter.html)

## Upstream Service Flow Fairness

The service flows in the same class receive approximately the same amount of bandwidth. Fairness resolves the bandwidth distribution disparity among various service flows including:

- non-bonded service flow vs bonded service flows
- Service flows on modems of different vendors, i.e Intel/TI vs Broadcom
- Service flows associated with different sized bonding groups, i.e. 1,2 4 channels

The upstream scheduler supports flow based queuing. When Upstream Service Flow Fairness is configured, the upstream scheduler determines the order and amount of BW a service flow should receive based on its current consumption relative to other flows in the flows in the same class.

Use the **cable upstream qos fairness** command to configure the Upstream Service Flow Fairness feature. Use this command in interface configuration mode (or MAC Domain configuration mode).

## Distribution of Traffic across all Channels in a USBG

When upstream channel bonding (USCB) is enabled, the Distribution of Traffic across all Channels in a USBG feature can be used to balance the bandwidth utilization across upstream channels on one upstream bonding group.

This feature balances the utilization only if there is one upstream channel bonding group configured per MAC domain.

### Restrictions:

- This feature is supported only on one upstream bonding group under a MAC domain. When multiple upstream bonding groups are configured under a MAC domain, the utilization is unfair.
- All the channels must be configured in one upstream bonding group under the same MAC domain.
- This feature is used only for UB-online cable modems.

The USCB Balancing Scheduler may be enabled or disabled using the **cable upstream balance-scheduler** command in the interface (config-if) configuration mode.

## DOCSIS 3.0 Load Balancing with USBG Smaller than Cable Modem Capabilities

When using USCB in a service group with USBGs containing fewer upstream channels than the total upstream channel set with DOCSIS 3.0 load balancing enabled, the CMTS can assign a Transmit Channel Set (TCS) to DOCSIS 3.0 cable modems for potential use which falls outside of the configured USBG. The CMTS will try to bind smaller UBGs and default single channel bonding groups into a bigger channel set in order to increase the cable modem services. For example, a DOCSIS 3.0 cable modem receiving the larger TCS can use these additional channels for dynamic service flow addition. The DOCSIS 3.0 Load Balancing feature can also move cable modems to upstream channels that are not explicitly configured with USBGs as a result of the larger TCS.

If you activate DOCSIS 3.0 Load Balancing while using upstream bonding, ensure that the upstream bonding group configuration is embedded and aligned by performing the following:

- Configure USBGs, which is matched to cable modem capabilities within the service group, such as a 4 channel USBG, 2 channel USBG, and 3 channel USBG as applicable.
- Ensure that configured USBGs are optimal for the upstream channel set based on modem capabilities within the service group. For example, if four upstream channels are available, channels 0+1 and 2+3 should each be an USBG to avoid dynamic TCS creating sub optimal bonding scenarios.
- Alternatively, you can choose to shut down any upstream channels that is not configured in USBGs which is not be used for bonding.

## Cisco cBR-8 CCAP Line Card Rate Limiting

The rate limiting functionality enables you control the aggregated rate and CPU consumption of upstream traffic for DOCSIS 3.0 bonded service flows on the Cisco cBR-8 CCAP line card. The rate limiting functionality is configured by default on the Cisco cBR-8 CCAP line card. However, the default configuration can be modified using the **cable upstream rate-limit-ccf** command.

The rate limiting functionality uses the following two rate limiting methods:

- Aggregated rate limiting—This is based on Peripheral Component Interconnect (PCI) bus aggregated throughput. The throughput is per line card for all bonded service flows. You can modify the default throughput and burst rate configuration. The maximum allowed throughput is 115 Mbps.
- CPU-based rate limiting—This method controls the CPU consumed by Continuous Concatenation and Fragmentation (CCF) and ensures that the line card functions properly when traffic is overloaded with bonded service flows. The default configuration allocates 50 per cent of CPU to CCF. You can modify the default CPU threshold value and burst rate as required.

## SID Tracking

The service ID (SID) tracking functionality enables you to track events related to upstream bandwidth requests and processing of grants. The SID tracker module can track events for a maximum of two service flows per MAC domain. The SID tracker module tracks up to 40,000 events per service flow on a cable interface line card.

You can enable SID tracking for the following types of events:

- DOCSIS 2.0 bandwidth request
- DOCSIS 3.0 bandwidth request
- Grant
- Pending grant (due to traffic congestion)
- Pending grant (due to shaping)

You can enable SID tracking using the **track** keyword along with the **debug cable interface sid** command. To verify SID tracking, use the **show interface cable upstream debug** command in privileged EXEC mode.

## Service ID Clusters

A Cisco CMTS router can assign one or more service ID clusters to the upstream bonded service flows (upstream service flows assigned to an upstream bonding group) at the time of service flow creation. A SID cluster contains one SID per upstream in a bonding group. A CM uses one of the SIDs defined in the SID cluster for the upstream interface when the CM sends a bandwidth request. The CM chooses a SID or a SID cluster based on the SID cluster switching criteria.

For example, assume that a CM has ranged on upstream channels from 1 to 4. The Cisco CMTS router creates a bonded service flow and assigns a single SID cluster to each upstream channel. That is SID1 for UP1, SID2 for UP2, SID3 for UP3, and SID4 for UP4. Now, the CM can send a bandwidth request using any of the four upstream channels. That is, the CM can request bandwidth on any of the upstream interfaces in the SID cluster using the SID defined for the particular upstream. The Cisco CMTS router grants bandwidth to the CM using any combination of upstream channels.

## How to Configure Upstream Channel Bonding



---

**Note** Before configuring the Upstream Channel Bonding feature, ensure that the fiber node is configured. The fiber node must be configured in accordance with the physical plant topology.

---



The following tasks describe how to configure Upstream Channel Bonding on the Cisco cBR-8 router:

## Enabling MTC Mode on a Cisco CMTS Router

This section explains how to enable the MTC mode on a Cisco CMTS router.

### Default MTC Mode Configuration on a Cisco CMTS Router

By default, the MTC mode is configured on a cable interface line card. With this default configuration, the Cisco CMTS router enables the MTC mode on a per MAC domain basis depending on the configuration file of each CM. When the CM configuration file has the bonded-bit (bit-0) enabled in TLV 43.9.3 (cable modem upstream required attribute mask), the Cisco CMTS router enables the CM to come online in the MTC mode. If the CM configuration file does not have the bonded-bit on, the CM comes online in non-MTC mode.

For more information on how to add the required attribute in the CM configuration file, see [Example: Enabling MTC Mode for a Single CM Using the CM Configuration File, on page 422](#).

### Enabling MTC Mode for All CMs



#### Note

- For DOCSIS 3.1 cable modems, the CMTS router must be configured to use MTC mode.
- This MTC mode configuration supersedes the default MTC mode configuration (per CM basis) with the required attribute. To disable the MTC mode for all CMs in a MAC domain, use the **no** form of the **cable mtc-mode** command. If the MTC mode is enabled and the forbidden mask of the upstream bonding in TLV 43.9.4 is disabled, the CM does not support the Upstream Channel Bonding feature.

#### Procedure

	Command or Action	Purpose
Step 1	<b>enable</b> <b>Example:</b> Router> <b>enable</b>	Enables privileged EXEC mode. Enter your password if prompted.
Step 2	<b>configure terminal</b> <b>Example:</b> Router# <b>configure terminal</b>	Enters global configuration mode.
Step 3	<b>interface cable</b> {slot/subslot/port   slot/subslot/cable-interface-index   slot/port   slot/cable-interface-index} <b>Example:</b> Router(config)# <b>interface cable</b> 7/0/0	Specifies the cable interface line card on a Cisco CMTS router.
Step 4	<b>cable mtc-mode</b> <b>Example:</b> Router(config-if)# <b>cable mtc-mode</b>	Enables MTC mode at the MAC interface for all CMs.

	Command or Action	Purpose
<b>Step 5</b>	<b>end</b> <b>Example:</b> Router(config-if)# <b>end</b>	Exits cable interface configuration mode and returns to privileged EXEC mode.

## Configuring UCSB Required Attribute

If the CM configuration file has TLV 43.9.3 (CM upstream required attribute mask) configured and bonded bit is set to 1, then the modem comes UB-online on a MAC domain basis. If the CM configuration file has no TLV 43.9.3 or the bonded bit is not set to 1, then the modem comes online with a single upstream channel on a MAC domain basis.



**Note** Without this configuration, the modem comes UB-online on the MAC domain regardless of whether the TLV 43.9.3 is configured in the modem configuration file.

### Procedure

	Command or Action	Purpose
<b>Step 1</b>	<b>enable</b> <b>Example:</b> Router> <b>enable</b>	Enables privileged EXEC mode. Enter your password if prompted
<b>Step 2</b>	<b>configure terminal</b> <b>Example:</b> Router# <b>configure terminal</b>	Enters global configuration mode.
<b>Step 3</b>	<b>interface cable</b> { <i>slot/subslot/port</i>   <i>slot/subslot/cable-interface-index</i>   <i>slot/port</i>   <i>slot/cable-interface-index</i> } <b>Example:</b> Router(config)# <b>interface cable</b> 7/0/0	Specifies the cable interface line card on a Cisco CMTS router.
<b>Step 4</b>	<b>cable mtc-mode required-attribute</b> <b>Example:</b> Router(config-if)# <b>cable mtc-mode required-attribute</b>	Enable enforcement of required CM attribute on UCSB.
<b>Step 5</b>	<b>end</b> <b>Example:</b> Router(config-if)# <b>end</b>	Exits cable interface configuration mode and returns to privileged EXEC mode.

## Creating a Bonding Group

An upstream bonding group is created by combining multiple upstream channels together on a cable interface line card.

### Procedure

	Command or Action	Purpose
Step 1	<b>enable</b> <b>Example:</b> Router> <b>enable</b>	Enables privileged EXEC mode. Enter your password if prompted.
Step 2	<b>configure terminal</b> <b>Example:</b> Router# <b>configure terminal</b>	Enters global configuration mode.
Step 3	<b>interface cable</b> { <i>slot/subslot/port</i>   <i>slot/subslot/cable-interface-index</i>   <i>slot/port</i>   <i>slot/cable-interface-index</i> } <b>Example:</b> Router(config)# <b>interface cable</b> 7/0/0	Specifies the cable interface line card on a Cisco CMTS router.
Step 4	<b>cable upstream bonding-group id</b> <b>Example:</b> Router(config-if)# <b>cable upstream bonding-group</b> 200	Creates the bonding group on the specified cable interface.
Step 5	<b>end</b> <b>Example:</b> Router(config-if)# <b>end</b>	Exits cable interface configuration mode and returns to privileged EXEC mode.

### What to do next

After creating an upstream bonding group, you must add upstream channels to the bonding group.

## Adding Upstream Channels to a Bonding Group



**Restriction** DOCSIS 3.0-certified CMs support only four upstream channels on an upstream bonding group. These CMs do not accept additional upstream channels that are added to a bonding group.

**Step 1** **enable**  
**Example:**  
 Router> **enable**

Enables privileged EXEC mode.

Enter your password if prompted.

**Step 2** **configure terminal**

**Example:**

```
Router# configure terminal
```

Enters global configuration mode.

**Step 3** **interface cable** { *slot/subslot/port* | *slot/subslot/cable-interface-index* | *slot/port* | *slot/cable-interface-index* }

**Example:**

```
Router(config)# interface cable 7/0/0
```

Specifies the cable interface line card on a Cisco CMTS router.

**Step 4** **cable upstream bonding-group** *id*

**Example:**

```
Router(config-if)# cable upstream bonding-group 200
```

Creates the bonding group on the specified interface.

**Step 5** **upstream** *number*

**Example:**

```
Router(config-upstream-bonding)# upstream 1
```

Enters upstream bonding configuration submode and adds an upstream channel to the upstream bonding group.

**Note** Upstream channel needs to be bonded to mac-domain first before adding it to the bonding group. For detailed configuration steps of the upstream channel bonding, please refer to [Configuration Example for Upstream Channel Bonding](#)

- Group 1: upstream channel 0-7
- Group 2: upstream channel 8-15

A maximum of 16 upstream channels can be configured for each MAC Domain, which are divided into two groups:

- Group 1: upstream channel 0-7
- Group 2: upstream channel 8-15

See Restrictions for Upstream Channel Bonding [Restrictions for Upstream Channel Bonding](#) , on page 393.

**Step 6** **end**

**Example:**

```
Router(config-upstream-bonding)# end
```

Exits upstream bonding configuration submode and returns to privileged EXEC mode.

## Adding Upstream Channel Ports to a Fiber Node

You must add upstream channel controllers to a fiber node in order to complete the basic upstream channel bonding configuration on a cable interface line card. The fiber node must contain all upstream and downstream controllers reached by the CMs.



### Restriction

- Configuration of a fiber node is valid only if all upstream channels inside the fiber node have different upstream frequencies.
- For any two upstream channels mapped to the upstream cable controllers in the same fiber node where a spectrum group is assigned to one upstream channel, and a frequency is assigned to the other upstream channel, any overlap between any bands associated with the spectrum group of the upstream channel and the frequency of the upstream channel will result in an invalid fiber node configuration. That is a fixed frequency cannot overlap with another upstream channel's available spectrum group bands.



### Note

The fiber node configuration must be done in accordance with the physical plant topology.

### Procedure

	Command or Action	Purpose
Step 1	<b>enable</b> <b>Example:</b> Router> <b>enable</b>	Enables privileged EXEC mode. <ul style="list-style-type: none"> <li>• Enter your password if prompted.</li> </ul>
Step 2	<b>configure terminal</b> <b>Example:</b> Router# <b>configure terminal</b>	Enters global configuration mode.
Step 3	<b>cable fiber-node</b> <i>fiber-node-id</i> <b>Example:</b> Router(config)# <b>cable fiber-node 2</b>	Enters fiber node configuration mode.
Step 4	<b>upstream Upstream-Cable</b> <i>slot/subslot/port</i> <b>Example:</b> Router(config-fiber-node)# <b>upstream Upstream-Cable 7/0/1</b>	Specifies the upstream channel ports for a fiber node.
Step 5	<b>end</b> <b>Example:</b> Router(config-fiber-node)# <b>end</b>	Exits fiber node configuration mode and returns to privileged EXEC mode.

## Configuring the Class-Based Weighted Fair Queuing

In the case of a class-based configuration, allocation of available bandwidth is dependent on the service flows that are active in a service class.

### Procedure

	Command or Action	Purpose
<b>Step 1</b>	<b>enable</b> <b>Example:</b> Router> <b>enable</b>	Enables privileged EXEC mode. Enter your password if prompted.
<b>Step 2</b>	<b>configure terminal</b> <b>Example:</b> Router# <b>configure terminal</b>	Enters global configuration mode.
<b>Step 3</b>	<b>interface cable</b> { <i>slot/subslot/port</i>   <i>slot/subslot/cable-interface-index</i>   <i>slot/port</i>   <i>slot/cable-interface-index</i> } <b>Example:</b> Router(config)# <b>interface cable</b> 7/0/0	Specifies the cable interface line card on a Cisco CMTS router.
<b>Step 4</b>	<b>cable upstream qos wfq class</b> <b>Example:</b> Router(config-if)# <b>cable upstream qos wfq class</b>	Enables class-based weighted fair queuing.
<b>Step 5</b>	<b>end</b> <b>Example:</b> Router(config-if)# <b>end</b>	Exits cable interface configuration mode and returns to privileged EXEC mode.

## Configuring the Activity-Based Weighted Fair Queuing

In the activity-based configuration, allocation of available bandwidth is based on the service class and the total number of service flows that are active in a map for the service class.

### Procedure

	Command or Action	Purpose
<b>Step 1</b>	<b>enable</b> <b>Example:</b> Router> <b>enable</b>	Enables privileged EXEC mode. Enter your password if prompted.
<b>Step 2</b>	<b>configure terminal</b> <b>Example:</b> Router# <b>configure terminal</b>	Enters global configuration mode.

	Command or Action	Purpose
Step 3	<b>interface cable</b> {slot/subslot/port   slot/subslot/cable-interface-index   slot/port   slot/cable-interface-index}  <b>Example:</b> Router(config)# <b>interface cable 7/0/0</b>	Specifies the cable interface line card on a Cisco CMTS router.
Step 4	<b>cable upstream qos wfq activity</b>  <b>Example:</b> Router(config-if)# <b>cable upstream qos wfq activity</b>	Enables activity-based weighted fair queuing.
Step 5	<b>end</b>  <b>Example:</b> Router(config-if)# <b>end</b>	Exits cable interface configuration mode and returns to privileged EXEC mode.

## Configuring Custom Weights for Service Flow Priorities

The WFQ functionality helps the Cisco CMTS router share the available bandwidth based on the weight of the service flow priorities specified for outstanding requests from an upstream service flow.

### Procedure

	Command or Action	Purpose
Step 1	<b>enable</b>  <b>Example:</b> Router> <b>enable</b>	Enables privileged EXEC mode.  Enter your password if prompted.
Step 2	<b>configure terminal</b>  <b>Example:</b> Router# <b>configure terminal</b>	Enters global configuration mode.
Step 3	<b>interface cable</b> {slot/subslot/port   slot/subslot/cable-interface-index   slot/port   slot/cable-interface-index}  <b>Example:</b> Router(config)# <b>interface cable 7/0/0</b>	Specifies the cable interface line card on a Cisco CMTS router.
Step 4	<b>cable upstream qos wfq weights priority0-priority7</b>  <b>Example:</b> Router(config-if)# <b>cable upstream qos wfq weights 10 20 30 40 50 60 70 80.</b>	Enables custom weight configuration for all the service flow priorities in a service class.  <b>Note</b> You must specify custom weight values for all the eight service flow priorities (0 to 7) when you modify the default weights of priorities. The valid range is from 1 to 255.

	Command or Action	Purpose
<b>Step 5</b>	<b>end</b> <b>Example:</b> Router(config-if) # <b>end</b>	Exits cable interface configuration mode and returns to privileged EXEC mode.

## Configuring the SID Cluster

This section explains how to configure and assign SID cluster to an upstream bonded service flow.

To achieve desired upstream bonded speed, you can use the **cable sid-cluster-group num-of-cluster** to achieve desired upstream bonded speeds, and this takes precedence over **cable sid-cluster-group dynamic**. Alternatively you can use a large upstream Max Traffic burst value in the cable modem file (such as 30 kB). The Max Concat burst value in the cable modem file does not need change because DOCSIS 3.0 uses continuous concatenations and fragmentation (CCF), and can therefore use the default value of 3044 in the Max Concat field.



**Note** If the **cable sid-cluster-group** command is not used, the router accepts the default SID cluster configuration. By default, **dynamic sid-cluster assignment** is configured. Similarly, if the **cable sid-cluster-switching** command is not used, the router accepts the default SID cluster switchover criterion. That is, only one request can be made using the SID cluster.

### Procedure

	Command or Action	Purpose
<b>Step 1</b>	<b>enable</b> <b>Example:</b> Router> <b>enable</b>	Enables privileged EXEC mode.  Enter your password if prompted.
<b>Step 2</b>	<b>configure terminal</b> <b>Example:</b> Router# <b>configure terminal</b>	Enters global configuration mode.
<b>Step 3</b>	<b>interface cable</b> {slot/subslot/port   slot/subslot/cable-interface-index   slot/port   slot/cable-interface-index} <b>Example:</b> Router(config)# <b>interface cable</b> 7/0/0	Specifies the cable interface line card on a Cisco CMTS router.
<b>Step 4</b>	<b>cable sid-cluster-group</b> [dynamic [max_rate_threshold]   req-multiplier value   num-of-cluster number] <b>Example:</b> Router(config-if) # <b>cable sid-cluster-group dynamic</b> Router(config-if) # <b>cable sid-cluster-group dynamic</b> 3000000000	Creates a SID cluster group. Starting from Cisco IOS XE Gibraltar 16.12.1z release, you can configure a maximum rate threshold for the service flow, because the original threshold is not appropriate in some cases. If the maximum rate of the service flow is larger than the configured threshold, two SIDs will be allocated to the service flow instead of one SID.



	Command or Action	Purpose
	<pre>Router(config-if)# cable sid-cluster-group req-multiplier 12  Router(config-if)# cable sid-cluster-group num-of-cluster 2</pre>	
<b>Step 5</b>	<p><b>cable sid-cluster-switching</b> [<b>max-outstanding-byte</b> <i>value</i>   <b>max-request</b> <i>value</i>   <b>max-time</b> <i>seconds</i>   <b>max-total-byte</b> <i>value</i>]</p> <p><b>Example:</b></p> <pre>Router(config-if)# cable sid-cluster-switching max-outstanding-byte 4444  Router(config-if)# cable sid-cluster-switching max-request 222  Router(config-if)# cable sid-cluster-switching max-time 444  Router(config-if)# cable sid-cluster-switching max-total-byte 67890</pre>	Specifies SID cluster switchover criteria.
<b>Step 6</b>	<p><b>end</b></p> <p><b>Example:</b></p> <pre>Router(config-if)# end</pre>	Exits cable interface configuration mode and returns to privileged EXEC mode.

### What to do next

Use the **show running-config all** command to verify the SID cluster configuration. Following is a sample output of the command:

```
Router# show running-config all
.
.
cable sid-cluster-group req-multiplier 4
```

## Configuring the Channel Timeout for a Cable Modem

The channel timeout configuration allows you to specify the maximum time that a CM can spend performing initial ranging on the upstream channels described in the Registration Response (REG-RSP) and REG-RSP-MP messages. The default channel timeout value (60 seconds) is automatically configured.

### Procedure

	Command or Action	Purpose
<b>Step 1</b>	<p><b>enable</b></p> <p><b>Example:</b></p> <pre>Router&gt; enable</pre>	<p>Enables privileged EXEC mode.</p> <p>Enter your password if prompted.</p>

	Command or Action	Purpose
<b>Step 2</b>	<b>configure terminal</b> <b>Example:</b> Router# <b>configure terminal</b>	Enters global configuration mode.
<b>Step 3</b>	<b>interface cable</b> { <i>slot/subslot/port</i>   <i>slot/subslot/cable-interface-index</i>   <i>slot/port</i>   <i>slot/cable-interface-index</i> } <b>Example:</b> Router(config)# <b>interface cable</b> 7/0/0	Specifies the cable interface line card on a Cisco CMTS router.
<b>Step 4</b>	<b>cable init-channel-timeout</b> <i>value</i> <b>Example:</b> Router(config-if)# <b>cable init-channel-timeout</b> 160	Specifies the maximum time that a CM can spend performing initial ranging on the upstream channels.
<b>Step 5</b>	<b>end</b> <b>Example:</b> Router(config-if)# <b>end</b>	Exits cable interface configuration mode and returns to privileged EXEC mode.

## Configuring Cable Upstream Resiliency

The cable upstream resiliency module ensures that a CM remains operational if one or more non-primary upstream service flows of the CM enter temporary or persistent error states. This module enables a Cisco CMTS router to handle various events and maintain the transmit channel set of each CM.

In the event of the primary upstream service flow failure, the upstream resiliency module forces the CM to go offline.

For a Multiple Transmit Channel (MTC) modem, the (NRTPS), Real-time Polling Service (RTPS), (UGS), and (UGS-AD) upstream service flows on an impaired upstream channel is moved to another good upstream channel in the cable modem without resetting the cable modem.

### Procedure

	Command or Action	Purpose
<b>Step 1</b>	<b>enable</b> <b>Example:</b> Router> <b>enable</b>	Enables privileged EXEC mode. Enter your password if prompted.
<b>Step 2</b>	<b>configure terminal</b> <b>Example:</b> Router# <b>configure terminal</b>	Enters global configuration mode.
<b>Step 3</b>	<b>cable upstream resiliency data-burst polling-interval</b> <i>number</i> <b>Example:</b>	Configures the polling interval for data-burst resiliency in seconds. The range is from 5 to 3600. The default configuration for polling-interval is 60.

	Command or Action	Purpose
	Router(config)# <b>cable upstream resiliency data-burst polling-interval 60</b>	
<b>Step 4</b>	<b>interface cable</b> {slot/subslot/port   slot/subslot/cable-interface-index   slot/port   slot/cable-interface-index}  <b>Example:</b> Router(config)# <b>interface cable 7/0/0</b>	Specifies the cable interface line card on a Cisco CMTS router.
<b>Step 5</b>	<b>cable upstream resiliency</b> {channel-down-detect number   data-burst snr number ufec number cfec number hysteresis number   modem-offline-detect number   on-failure {disable-channel   extended-ranging   reset-modem}   sf-move {NRTPS   RTPS   UGS   UGS-AD} }  <b>Example:</b> Router(config-if)# <b>cable upstream resiliency channel-down-detect 68</b>  Router(config-if)# <b>cable upstream resiliency modem-offline-detect 16</b>  Router(config-if)# <b>cable upstream resiliency on-failure disable-channel</b>  Router(config-if)# <b>cable upstream resiliency sf-move NRTPS</b>  Router(config-if)# <b>cable upstream resiliency sf-move RTPS</b>  Router(config-if)# <b>cable upstream resiliency sf-move UGS</b>  Router(config-if)# <b>cable upstream resiliency sf-move UGS-AD</b>  Router(config-if)# <b>cable upstream resiliency data-burst snr 24 ufec 1 cfec 0 hysteresis 3</b>	Configures upstream resiliency for bonded upstream service flows.
<b>Step 6</b>	<b>end</b>  <b>Example:</b> Router(config-if)# <b>end</b>	Exits cable interface configuration mode and returns to privileged EXEC mode.

## Configuring Rate Limiting on the Cisco cBR-8 CCAP Line Card

The rate limiting functionality is configured by default on the Cisco cBR-8 CCAP line card. However, the default configuration can be modified using the cable upstream rate-limit-ccf command.

## Procedure

	Command or Action	Purpose
<b>Step 1</b>	<b>enable</b> <b>Example:</b> Router> <b>enable</b>	Enables privileged EXEC mode. <ul style="list-style-type: none"> <li>• Enter your password if prompted.</li> </ul>
<b>Step 2</b>	<b>configure terminal</b> <b>Example:</b> Router# <b>configure terminal</b>	Enters global configuration mode.
<b>Step 3</b>	<b>cable upstream rate-limit-ccf</b> [ <b>aggregated-burst</b> <i>value</i>   <b>aggregated-throughput</b> <i>value</i>   <b>cpu-burst</b> <i>value</i>   <b>cpu-threshold</b> <i>value</i> ] <b>Example:</b> Router(config)# <b>cable upstream rate-limit-ccf aggregated-burst 25000</b>  Router(config)# <b>cable upstream rate-limit-ccf aggregated-throughput 540000</b>  Router(config)# <b>cable upstream rate-limit-ccf cpu-burst 30</b>  Router(config)# <b>cable upstream rate-limit-ccf cpu-threshold 60</b>	Configures rate limiting parameters for upstream bonded service flows on a cable interface line card.
<b>Step 4</b>	<b>end</b> <b>Example:</b> Router(config)# <b>end</b>	Exits global configuration mode and returns to privileged EXEC mode.

## Enabling Upstream Related Events for CM Status Reports

You can enable upstream related CM status events only on a cable interface line card. You can enable the following upstream related CM status events per interface using the `cable cm-status enable` command:

- T4 time-out
- T3 re-tries exceeded
- Successful ranging after T3 re-tries exceeded

For details on how to enable upstream and downstream related CM status events, see the Wideband Modem Resiliency feature guide at the following URL:

[http://www.cisco.com/en/US/docs/ios/cable/configuration/guide/ubr\\_wm\\_resiliency.html](http://www.cisco.com/en/US/docs/ios/cable/configuration/guide/ubr_wm_resiliency.html)

## Modifying the Bonding Group Attributes

Bonding group attributes are automatically configured for each upstream bonding group. You can modify them using the `attributes` command in upstream bonding configuration mode.

## Procedure

	Command or Action	Purpose
Step 1	<b>enable</b> <b>Example:</b> Router> <b>enable</b>	Enables privileged EXEC mode. Enter your password if prompted.
Step 2	<b>configure terminal</b> <b>Example:</b> Router# <b>configure terminal</b>	Enters global configuration mode.
Step 3	<b>interface cable</b> {slot/subslot/port   slot/subslot/cable-interface-index   slot/port   slot/cable-interface-index} <b>Example:</b> Router(config)# <b>interface cable</b> 7/0/0	Specifies the cable interface line card on a Cisco CMTS router.
Step 4	<b>cable upstream bonding-group id</b> <b>Example:</b> Router(config-if)# <b>cable upstream bonding-group</b> 200	Creates the bonding group on the specified cable interface and enters the upstream bonding configuration mode.
Step 5	<b>attributes value</b> <b>Example:</b> Router(config-upstream-bonding)# <b>attributes</b> eeeeeeee	Modifies the attribute value for the specified bonding group.
Step 6	<b>end</b> <b>Example:</b> Router(config-upstream-bonding)# <b>end</b>	Exits upstream bonding configuration mode and returns to privileged EXEC mode.

## Modifying the Ranging Poll Interval on Upstream Channels

You can change the default ranging poll interval (20 seconds) on upstream channels using the cable upstream ranging-poll command in cable interface configuration mode. You can also specify the T4 timeout multiplier value using this command.

For information on T4 Multiplier, see [T4 Multiplier, on page 399](#).



**Note** We recommend that you do not modify the default ranging poll interval unless required. With the default configuration, a DOCSIS 2.0 CM in non-MTC mode performs ranging on one upstream channel every 20 seconds.

## Procedure

	Command or Action	Purpose
<b>Step 1</b>	<b>enable</b> <b>Example:</b> Router> <b>enable</b>	Enables privileged EXEC mode. Enter your password if prompted.
<b>Step 2</b>	<b>configure terminal</b> <b>Example:</b> Router# <b>configure terminal</b>	Enters global configuration mode.
<b>Step 3</b>	<b>interface cable</b> {slot/subslot/port   slot/subslot/cable-interface-index   slot/port   slot/cable-interface-index} <b>Example:</b> Router(config)# <b>interface cable</b> 7/0/0	Specifies the cable interface line card on a Cisco CMTS router.
<b>Step 4</b>	<b>cable upstream ranging-poll</b> [interval value   t4-multiplier timeout_value] <b>Example:</b> Router(config-if)# <b>cable upstream ranging-poll</b> interval 24000 t4-multiplier 4	Specifies the ranging poll interval for upstream channels. <b>Note</b> If <b>t4-multiplier timeout_value</b> is not configured, then the CMTS uses the the T4 timeout of the modem. For example, if the T4 timeout of the modem is 90 seconds, then the CMTS will apply 3 as T4 multiplier for the modem.
<b>Step 5</b>	<b>end</b> <b>Example:</b> Router(config-if)# <b>end</b>	Exits cable interface configuration mode and returns to privileged EXEC mode.

## Configuring the Reduced Channel Set Assignment

You need to configure the transmit power offset budget to enable the Cisco CMTS router to reduce upstream channel set assignment based on the total power budget of the CM.



**Note** The threshold value specified for the power budget offset (**max-channel-power-offset**) must be less than the power threshold value (**power-adjust continue**) that determines the value of the Ranging Status field in the Ranging Response (RNG-RSP) messages that the Cisco CMTS router sends to the CM. You can specify the power threshold value using the **cable upstream power-adjust** command.

### Before you begin

- Configure extended transmit power using the **cable tx-power-headroom** command in global configuration mode.
- Ensure that corresponding static bonding groups are configured.

## Procedure

	Command or Action	Purpose
<b>Step 1</b>	<b>enable</b> <b>Example:</b> Router> <b>enable</b>	Enables privileged EXEC mode. Enter your password if prompted.
<b>Step 2</b>	<b>configure terminal</b> <b>Example:</b> Router# <b>configure terminal</b>	Enters global configuration mode.
<b>Step 3</b>	<b>interface cable</b> { <i>slot/subslot/port</i>   <i>slot/subslot/cable-interface-index</i>   <i>slot/port</i>   <i>slot/cable-interface-index</i> } <b>Example:</b> Router(config)# <b>interface cable 7/0/0</b>	Specifies the cable interface line card on a Cisco CMTS router.
<b>Step 4</b>	<b>cable upstream max-channel-power-offset</b> <i>dB-value</i> <b>Example:</b> Router(config-if)# <b>cable upstream</b> <b>max-channel-power-offset 2</b>	Specifies the power offset value for upstream channels.
<b>Step 5</b>	<b>end</b> <b>Example:</b> Router(config-if)# <b>end</b>	Exits cable interface configuration mode and returns to privileged EXEC mode.

## Configuring DOCSIS Extended Transmit Power Feature

The DOCSIS Extended Transmit Power feature is enabled by default on the Cisco CMTS. However, the default configuration can be modified using the cable upstream ext-power command.

## Procedure

	Command or Action	Purpose
<b>Step 1</b>	<b>enable</b> <b>Example:</b> Router> <b>enable</b>	Enables privileged EXEC mode. Enter your password if prompted.
<b>Step 2</b>	<b>configure terminal</b> <b>Example:</b> Router# <b>configure terminal</b>	Enters global configuration mode.
<b>Step 3</b>	<b>interface cable</b> { <i>slot/subslot/port</i>   <i>slot/subslot/cable-interface-index</i>   <i>slot/port</i>   <i>slot/cable-interface-index</i> }	Specifies the cable interface line card on a Cisco CMTS router.

	Command or Action	Purpose
	<b>Example:</b> Router(config)# <b>interface cable 7/0/0</b>	
<b>Step 4</b>	<b>cable upstream ext-power</b> <b>Example:</b> Router(config-if)# <b>cable upstream ext-power</b>	Enables the DOCSIS Extended Transmit Power feature on the Cisco CMTS.  Using the <b>no</b> form of this command disables the DOCSIS Extended Transmit Power feature.
<b>Step 5</b>	<b>end</b> <b>Example:</b> Router(config-if)# <b>end</b>	Exits interface configuration mode and returns to privileged EXEC mode.

## Troubleshooting Tips

The following debug commands help you troubleshoot an improper upstream channel bonding configuration and its related features:

- **debug cable cm-status**—Provide debugging information about CM status messages on the Cisco CMTS routers.
- **debug cable mdd**—Provides debugging information about MAC domain descriptor (MDD).
- **debug cable md-sg**—Provides information about service group debugging messages.
- **debug cable ubg**—Provides debugging information about upstream bonding groups.

## Configuration Example for Upstream Channel Bonding

The following example shows how to configure the basic upstream channel bonding on the Cisco cBR-8 CCAP line card interface 7/0/0 on the Cisco cBR-8 router:

```

controller Upstream-Cable 7/0/0
us-channel 0 frequency 10000000
us-channel 0 channel-width 3200000 3200000
us-channel 0 ingress-noise-cancellation 50
us-channel 0 docsis-mode atdma
us-channel 0 minislot-size 2
us-channel 0 modulation-profile 221
us-channel 0 equalization-coefficient
no us-channel 0 shutdown
us-channel 1 frequency 16400000
us-channel 1 channel-width 6400000 6400000
us-channel 1 ingress-noise-cancellation 50
us-channel 1 docsis-mode atdma
us-channel 1 minislot-size 1
us-channel 1 modulation-profile 221
us-channel 1 equalization-coefficient
no us-channel 1 shutdown
us-channel 2 frequency 22800000
us-channel 2 channel-width 6400000 6400000
us-channel 2 docsis-mode atdma
us-channel 2 minislot-size 1
us-channel 2 modulation-profile 221
us-channel 2 equalization-coefficient

```



```

no us-channel 2 shutdown
us-channel 3 frequency 29200000
us-channel 3 channel-width 6400000 6400000
us-channel 3 docsis-mode atdma
us-channel 3 minislots-size 1
us-channel 3 modulation-profile 221
us-channel 3 equalization-coefficient
no us-channel 3 shutdown
us-channel 4 channel-width 1600000 1600000
us-channel 4 docsis-mode tdma
us-channel 4 minislots-size 4
us-channel 4 modulation-profile 21
us-channel 4 shutdown
us-channel 5 channel-width 1600000 1600000
us-channel 5 docsis-mode atdma
us-channel 5 minislots-size 4
us-channel 5 modulation-profile 221
us-channel 5 shutdown
!

interface Cable7/0/0
load-interval 30
downstream Integrated-Cable 7/0/0 rf-channel 0
downstream Integrated-Cable 7/0/0 rf-channel 8
downstream Integrated-Cable 7/0/0 rf-channel 16
upstream 0 Upstream-Cable 7/0/0 us-channel 0
upstream 1 Upstream-Cable 7/0/0 us-channel 1
upstream 2 Upstream-Cable 7/0/0 us-channel 2
upstream 3 Upstream-Cable 7/0/0 us-channel 3
no cable upstream 0 equalization-error-recovery
no cable upstream 1 equalization-error-recovery
no cable upstream 2 equalization-error-recovery
no cable upstream 3 equalization-error-recovery
cable upstream 7 attribute-mask 1FF
cable upstream bonding-group 1
upstream 0
upstream 1
upstream 2
attributes 80000000
cable bundle 1
cable map-advance static 2000
cable sync-interval 121
cable reduction-mode mta-battery enable
cable privacy accept-self-signed-certificate
end

cable fiber-node 1
description Feed Mac Domain: Cable7/0/0
downstream Integrated-Cable 7/0/0
upstream Upstream-Cable 7/0/0

```



**Note** Bonded channels are typically from the same connector; however, channels from different connectors in the same MAC domain can also be bonded together. A single MAC domain can support multiple channel bonding groups.



**Note** Up to 8 frequencies can be stacked to one upstream-cable controller. Once the upstream-cable controller has 8 frequencies stacked, no more frequency left for the adjacent upstream-cable controller.

## Example: Enabling MTC Mode for a Single CM Using the CM Configuration File

The following example shows how to enable the MTC required attribute using the CM configuration file:

```
03 (Net Access Control) = 1
Unknown Type 005 = 01 01 01
18 (Maximum Number of CPE) = 4
24 (Upstream Service Flow Encodings)
  S01 (Service Flow Reference) = 1
  S06 (QoS Parameter Set Type) = 7
  S10 (Min Reserved Traffic Rate)= 500000
25 (Downstream Service Flow Encodings)
  S01 (Service Flow Reference) = 2
  S06 (QoS Parameter Set Type) = 7
  S10 (Min Reserved Traffic Rate) = 1000000
29 (Privacy Enable) = 0
43 (Vendor Specific Options)
  S08 (Vendor ID) = ff ff ff
  S09 (Unknown sub-type) = 03 04 80 00 00 00
```

## Verifying the Upstream Channel Bonding Configuration

Use the following **show** commands to verify the upstream channel bonding configuration:

- **show cable mac-domain upstream-service-group**
- **show cable fiber-node**
- **show interface cable upstream**
- **show interface cable service-flow**
- **show cable modem**

To verify the runtime statistics of the upstream service group on a cable interface line card, use the **show cable mac-domain upstream-service-group** command.

To verify the configuration of a fiber node, use the **show cable fiber-node** command.

To verify the bonding groups configured on a cable interface line card, use the **show interface cable upstream** command.

To verify upstream bonding information on a cable interface line card, use the **show interface cable service-flow** command.

To verify the transmit power levels on a CM, use the **show cable modem** command.

## Verifying Weighted Fair Queuing for Upstream Service Flows

To verify WFQ parameters configured for upstream service flows on a cable interface line card, use the **show interface cable mac-scheduler** command.

## Verifying Rate Limiting for Upstream Bonded Service Flows

To verify the rate limiting criteria configured on the Cisco cBR8 CCAP line card for upstream bonded service flows, use the **show cable rate-limit-ccf** command.



**Note** The **show cable rate-limit-ccf** command is applicable only to the Cisco cBR8 CCAP cable interface line card.

## Verifying Extended Power Transmission

To verify that a CM is transmitting at a higher power level, use the **show cable modem** command.

To list all the CMs that are transmitting at higher power level, use the **show cable modem extended-power** command.

## Additional References

The following sections provide references related to the Upstream Channel Bonding feature.

### Technical Assistance

Description	Link
<p>The Cisco Support website provides extensive online resources, including documentation and tools for troubleshooting and resolving technical issues with Cisco products and technologies.</p> <p>To receive security and technical information about your products, you can subscribe to various services, such as the Product Alert Tool (accessed from Field Notices), the Cisco Technical Services Newsletter, and Really Simple Syndication (RSS) Feeds.</p> <p>Access to most tools on the Cisco Support website requires a Cisco.com user ID and password.</p>	<a href="http://www.cisco.com/techsupport">http://www.cisco.com/techsupport</a>

## Feature Information for Upstream Channel Bonding

Use Cisco Feature Navigator to find information about the platform support and software image support. Cisco Feature Navigator enables you to determine which software images support a specific software release, feature set, or platform. To access Cisco Feature Navigator, go to the <https://cfmg.cisco.com/> link. An account on the Cisco.com page is not required.



**Note** The following table lists the software release in which a given feature is introduced. Unless noted otherwise, subsequent releases of that software release train also support that feature.

**Table 84: Feature Information for Upstream Channel Bonding**

<b>Feature Name</b>	<b>Releases</b>	<b>Feature Information</b>
Add hysteresis timer between CM-STATUS 24 and OPT measurement	Cisco IOS XE Dublin 17.12.1z	In this release, configurable Interval between CM-STATUS 24 and OPT Measurement is being added.
Support for 4 OFDM channel bonding in cBR8	Cisco IOS XE Dublin 17.12.1z	This release introduces the feature where a mac-domain can operate in D3.1 and D4.0 mode based on which mode the mac-domain is configured.
Upstream Channel Bonding	Cisco IOS XE Fuji 16.7.1	This feature was integrated on the Cisco cBR Series Converged Broadband Router.
User-Configurable Dynamic SID Cluster Threshold	Cisco IOS XE Gibraltar 16.12.1z	This feature was introduced on the Cisco cBR Series Converged Broadband Router.



## CHAPTER 24

# Dynamic Bonding Group

---

This document describes how to configure Dynamic Bonding Group that helps manage resource of all downstream bonding groups by automatically creating bonding groups.

Your software release may not support all the features that are documented in this module. For the latest feature information and caveats, see the release notes for your platform and software release. The Feature Information Table at the end of this document provides information about the documented features and lists the releases in which each feature is supported.

Use Cisco Feature Navigator to find information about platform support and Cisco software image support. To access Cisco Feature Navigator, go to <http://tools.cisco.com/ITDIT/CFN/>. An account on <http://www.cisco.com/> is not required.

- [Hardware Compatibility Matrix for the Cisco cBR Series Routers, on page 425](#)
- [Information About Dynamic Bonding Group, on page 427](#)
- [Overview of Dynamic Bonding Group, on page 427](#)
- [How to configure Dynamic Bonding Group, on page 428](#)
- [Feature Information for Dynamic Bonding Group, on page 439](#)

## Hardware Compatibility Matrix for the Cisco cBR Series Routers



---

**Note** The hardware components that are introduced in a given Cisco IOS-XE Release are supported in all subsequent releases unless otherwise specified.

---

Table 85: Hardware Compatibility Matrix for the Cisco cBR Series Routers

Cisco CMTS Platform	Processor Engine	Interface Cards
Cisco cBR-8 Converged Broadband Router	<p><b>Cisco IOS-XE Release 16.5.1 and Later Releases</b></p> <p>Cisco cBR-8 Supervisor:</p> <ul style="list-style-type: none"> <li>• PID—CBR-SUP-250G</li> <li>• PID—CBR-CCAP-SUP-160G</li> </ul>	<p><b>Cisco IOS-XE Release 16.5.1 and Later Releases</b></p> <p>Cisco cBR-8 CCAP Line Cards:</p> <ul style="list-style-type: none"> <li>• PID—CBR-LC-8D30-16U30</li> <li>• PID—CBR-LC-8D31-16U30</li> <li>• PID—CBR-RF-PIC</li> <li>• PID—CBR-RF-PROT-PIC</li> <li>• PID—CBR-CCAP-LC-40G</li> <li>• PID—CBR-CCAP-LC-40G-R</li> <li>• PID—CBR-CCAP-LC-G2-R</li> <li>• PID—CBR-SUP-8X10G-PIC</li> <li>• PID—CBR-2X100G-PIC</li> </ul> <p>Digital PICs:</p> <ul style="list-style-type: none"> <li>• PID—CBR-DPIC-8X10G</li> <li>• PID—CBR-DPIC-2X100G</li> </ul> <p>Cisco cBR-8 Downstream PHY Module:</p> <ul style="list-style-type: none"> <li>• PID—CBR-D31-DS-MOD</li> </ul> <p>Cisco cBR-8 Upstream PHY Modules:</p> <ul style="list-style-type: none"> <li>• PID—CBR-D31-US-MOD</li> </ul>



**Note** Do not use DPICs (8X10G and 2x100G) to forward IP traffic, as it may cause buffer exhaustion, leading to line card reload.

The only allowed traffic on a DPIC interface is DEPI, UEPI, and GCP traffic from the Cisco cBR-8 router to Remote PHY devices. Other traffic such as DHCP, SSH, and UTSC should flow via another router, since DPICs cannot be used for normal routing.

# Information About Dynamic Bonding Group

Dynamic Bonding Group (DBG) helps manage the resource of all downstream bonding groups, including automatically creating and reclaiming the downstream bonding groups.

## Overview of Dynamic Bonding Group

To reduce the effort required in configuring and managing RCC, the DBG feature implements the automatic creating and reclaiming of the downstream bonding groups. DBG creates the bonding group automatically depending on the channel's load usage. With DBG, the modem is assigned the downstream bonding group without any static RCC configuration. The load balancing feature leverages DBG to balance traffic among all channels. DBG also accommodates primary channel and CM capacity distributions automatically.

DBG also accommodates primary channel and CM capacity distributions automatically.

Dynamic Bonding Group supports the following:

- Support 896 bonding groups per CLC for CBR-CCAP-LC-40G and CBR-CCAP-LC-40G-R cards.
- Support creating DBGs and reclaiming DBG.
- Support DOCSIS 3.0 and DOCSIS 3.1 channel types.
- Support DOCSIS 3.0 and DOCSIS 3.1 load balance.
- Supports DBG interoperation — Modem registration and load balancing.
- Enhance dynamic load balance — Fixed primary channel movement.
- Enhance raider FPGA SQF — Fairness in channel utilization.

# How to configure Dynamic Bonding Group

## Enable Dynamic Bonding Group

Table 86: Feature History

Feature Name	Release Information	Feature Description
Configure the time interval between DBG unused and reclaim.	Cisco IOS XE Dublin 17.12.1w	In this release, you can use the <b>cable dynamic-bonding-group reclaim-hold-interval</b> command to configure a time interval in seconds between DBG unused and reclaim. Configuring this command has the following benefits: <ul style="list-style-type: none"> <li>• Reduces the chance of receiving the <b>AOM download to CPP stuck</b> or <b>AOM download to CPP queue</b> error messages.</li> <li>• Increasing the hold interval can help you avoid <b>DBG reclaim</b> or <b>DBG create</b> requests.</li> </ul>
Ability to create 8-channel DBG with contiguous frequency channels	Cisco IOS XE Bengaluru 17.6.1x	Some CMs change to downstream partial mode when moving on the DBG with disconnected frequency channels. This feature allows you to create 8-channel DBG with contiguous frequency channels for load balance purpose.

To enable DBG, run the following commands:

```

ROUTER# config t
Enter configuration commands, one per line. End with CNTL/Z.
ROUTER(config)# cable dynamic-bonding-group
ROUTER(config)# end
ROUTER#
ROUTER#
ROUTER# show run
ROUTER# show running-config | in dynamic-bonding
cable dynamic-bonding-group

```

Sometimes an 8-channel DBG is created with discontinuous frequency channels (such as 0–5 and 8–9) for load balance purpose. In this case, dual tuner 8-channel CM with BRCM3380 chipset may change to downstream partial mode when moving on the DBG with discontinuous frequency channels. To avoid this



issue, you can force the cBR-8 router to create 8-channel DBG with contiguous frequency channels using the following command:

```
ROUTER# config terminal
Enter configuration commands, one per line. End with CNTL/Z.
ROUTER(config)# cable dynamic-bonding-group eight-contiguous-channel
```

## Enable DS-Resiliency and Configure Resiliency Bonding Group

To make sure that the modem remains w-online with maximum downstream capability when several rf channels are impaired, enable ds-resiliency feature by running the following commands:

```
Router# config t
Enter configuration commands, one per line. End with CNTL/Z.
Router(config)# cable resiliency ds-bonding
Router(config)# end
Router#
Router# show running-config | in resiliency
cable resiliency ds-bonding
Router#
Router# config t
Enter configuration commands, one per line. End with CNTL/Z.
Router(config)# interface wideband-Cable 3/0/1:30
Router(config-if)# cable ds-resiliency
Wideband-Cable3/0/1:30 is set to WB resiliency bonding group.
Remove any existing bundle and rf-channel configuration.
Router(config-if)#end
Router#
Router#show running-config interface wideband-Cable 3/0/1:30
Building configuration...
Current configuration : 61 bytes
!
interface Wideband-Cable3/0/1:30
cable ds-resiliency
end
```

## Enable ACFE

Enable ACFE feature to make sure that modem registration is not blocked because of QoS failures:

```
Router# config t
Enter configuration commands, one per line. End with CNTL/Z.
Router(config)# cable acfe enable
Router(config)# end
Router# show running-config | in acfe
cable acfe enable
```

## Configure Interface Mac-Domain and Fiber-Node



**Note** The recommended size of service group is 32 or 48. The recommended primary channel distribution is one primary channel for contiguous four channels, such as 0, 4, 8, 12, 16, 20, 24, 28 and so on.

To set up interface mac-domain and fiber-node, run the following commands:

```
Router# show running-config interface c3/0/1
```

```

Building configuration...
Current configuration : 963 bytes
!
interface Cable3/0/1
downstream Integrated-Cable 3/0/1 rf-channel 0
downstream Integrated-Cable 3/0/1 rf-channel 4
downstream Integrated-Cable 3/0/1 rf-channel 8
downstream Integrated-Cable 3/0/1 rf-channel 12
downstream Integrated-Cable 3/0/1 rf-channel 16
downstream Integrated-Cable 3/0/1 rf-channel 20
downstream Integrated-Cable 3/0/1 rf-channel 24
downstream Integrated-Cable 3/0/1 rf-channel 28
upstream 0 Upstream-Cable 3/0/1 us-channel 0
upstream 1 Upstream-Cable 3/0/1 us-channel 1
upstream 2 Upstream-Cable 3/0/1 us-channel 2
upstream 3 Upstream-Cable 3/0/1 us-channel 3
upstream 4 Upstream-Cable 3/0/1 us-channel 4
upstream 5 Upstream-Cable 3/0/1 us-channel 5
upstream 6 Upstream-Cable 3/0/1 us-channel 6
upstream 7 Upstream-Cable 3/0/1 us-channel 7
cable upstream bonding-group 1
upstream 0
upstream 1
attributes 80000002
cable upstream bonding-group 2
upstream 2
upstream 3
attributes 80000000
cable bundle 255
end

Router# show cab
Router# show cable fib
Router# show cable fiber-node 1
Fiber-Node 1
  Channel(s) : downstream Integrated-Cable 3/0/1: 0-31
  Channel ID(s): 1 2 3 4 5 6 7 8 9 10 11 12 13 14
                15 16 17 18 19 20 21 22 23 24 25 26 27 28
                29 30 31 32
  Upstream-Cable 3/0/1
    FN Config Status: Configured (status flags = 0x01)
    MDD Status: Valid
Router# show running-config | sec fiber-node 1
cable fiber-node 1
  downstream Integrated-Cable 3/0/1
  upstream Upstream-Cable 3/0/1

```

Example of OFDM configured in the fiber node and added as part of the dynamic bonding group.

```

Router# show cable dynamic-bonding-group summary
Dynamic bonding group: Enable
BG ID BG Name      BG Size  CMs   ServFlows Create Time           Create Client      BG
State              RFid list
9219 Wi1/0/4:2     33       36    36           Nov 7  01:56:27.406     MODEM_ONLINE
OPERATIONAL          9216-9247, 9375
9220 Wi1/0/4:3     33       10    10           Nov 7  02:04:31.142     MODEM_ONLINE
OPERATIONAL          9248-9279, 9375
9221 Wi1/0/4:4     8         1     1           Nov 7  02:06:09.949     MODEM_ONLINE
OPERATIONAL          9248-9255

Router# show controller integrated-Cable 1/0/0 rf-channel 158
Load for five secs: 8%/1%; one minute: 8%; five minutes: 8%
Time source is NTP, *14:07:30.643 EST Fri Nov 17 2017
Chan State Admin Mod-Type  Start      Width    PLC      Profile-ID  dcid  power

```

```

output
                                Frequency
158 UP      UP  OFDM      258000000  48000000  279000000      100      159  34.0  NORMAL

Router# show cable fiber-node 10
Load for five secs: 9%/0%; one minute: 9%; five minutes: 8%
Time source is NTP, *13:59:39.571 EST Fri Nov 17 2017

-----

Fiber-Node 10
Channel(s)   : downstream Integrated-Cable 1/0/0: 0-63, 158
Channel ID(s):  1  2  3  4  5  6  7  8  9  10 11 12 13 14
                15 16 17 18 19 20 21 22 23 24 25 26 27 28
                29 30 31 32 33 34 35 36 37 38 39 40 41 42
                43 44 45 46 47 48 49 50 51 52 53 54 55 56
                57 58 59 60 61 62 63 64 159
Upstream-Cable 1/0/0
  FN Config Status: Configured (status flags = 0x01)
  MDD Status: Valid

```

## Enable Load Balancing for DOCSIS 3.0 and DOCSIS 3.1

To enable DOCSIS load balancing, run the `cable load-balance docsis-enable` command. When DOCSIS load balancing is enabled, run the `cable load-balance docsis30-enable` command to enable load balancing for DOCSIS 3.0 and DOCSIS 3.1.



---

**Note** The `cable load-balance docsis30-enable` command enables load balancing for DOCSIS 3.0 and DOCSIS 3.1.

---

## Enable DOCSIS 3.0 and DOCSIS 3.1 Static Load Balance

To balance the load of primary channels, enable static load balance by running the following commands:

```

ROUTER# config t
Enter configuration commands, one per line. End with CNTL/Z.
ROUTER(config)# cable load-balance docsis30-enable static
ROUTER(config)# end
ROUTER# show cable load-balance
DOCSIS LB Enabled: Yes
DOCSIS 2.0 LB Enabled: Yes
DOCSIS 3.0 LB Enabled: Yes
DOCSIS 3.0 Static LB Enabled: Yes
DOCSIS 3.0 Dynamic Downstream LB Enabled: No

```

## Enable DOCSIS 3.0 and DOCSIS 3.1 General Load Balance Group

To enable general load balance group, run the following commands:

```

Router# config t
Enter configuration commands, one per line. End with CNTL/Z.
Router(config)# cable load-balance docsis-group fn 1 md c3/0/1
Router(config-lb-group)# no disable

```

```

Router(config-lb-group)# end
Router# show cable load-balance
DOCSIS LB Enabled: Yes
DOCSIS 2.0 LB Enabled: No
159
DOCSIS 3.0 LB Enabled: Yes
DOCSIS 3.0 Static LB Enabled: Yes
DOCSIS 3.0 Dynamic Downstream LB Enabled: Yes
DOCSIS 3.0 Dynamic Upstream LB Enabled: Yes
DOCSIS      Status Interval  DCC mask  Policy      Method Threshold

DOCSIS 3.0 General LB
MD          FN  Group ID      S Intv  DCC mask  Policy  Mtd   MD-CM-SG  Threshold
                               /UCC                               D/U

M/E/U/P/S
Ca3/0/1  1    2147557888 E 90   0xF8(0)/N 0      u/u      0x91010B  5/10/70/70/50

```

## Enable Dynamic Load Balance and Fixed-Primary Channel Movement



**Note** To reduce service outage while enabling dynamic load balancing, enable fixed primary channel movement.

To balance the load of all of downstream channels based on utilization, enable dynamic load balance by running the following commands:

```

Router# config t
Enter configuration commands, one per line. End with CNTL/Z.
Router(config)# cable load-balance docsis30-enable dynamic downstream
Router(config)# end
Router#
Router# show cable load-balance
DOCSIS LB Enabled: Yes
DOCSIS 2.0 LB Enabled: No
DOCSIS 3.0 LB Enabled: Yes
DOCSIS 3.0 Static LB Enabled: Yes
DOCSIS 3.0 Dynamic Downstream LB Enabled: Yes
DOCSIS 3.0 Dynamic Upstream LB Enabled: Yes
DOCSIS      Status Interval  DCC mask  Policy      Method Threshold
Group                               /UCC        DS/US  M/E/U/P/S
1          GE      30      0xF8(0)/N 0      m/m      5/10/70/70/50

DOCSIS 3.0 General LB
MD          FN  Group ID      S Intv  DCC mask  Policy  Mtd MD-CM-SG  Threshold
                               /UCC                               D/U
Ca3/0/1  1    2147557888 E 90   0xF8(0)/N 0      u/u 0x91050A  5/10/70/70/50
Router#
Router# config t
Enter configuration commands, one per line. End with CNTL/Z.
Router(config)# cable load-balance fixed-primary-channel
Router(config)# end
Router#
Router# show run
Router# show running-config | in fixed
cable load-balance fixed-primary-channel

```

## Verifying Dynamic Bonding Group Configuration

To verify that the DBGs are created:

Check the modem's primary wideband interface by using the **show cable modem wideband channel** command:

```
Router# show cable modem 4800.33ee.ebee wideband channel
MAC Address      IP Address      I/F      MAC      DSxUS      Primary
                  State
4800.33ee.ebee   30.132.15.246  C3/0/1/UB  w-online  32x2      Wi3/0/1:3
Router# scm 4800.33ee.ebee ver
```

Check the modem's downstream tuner capability by using the **show cable modem verbose | in DS Tuner** command.

```
Router# show cable modem 4800.33ee.ebee verbose | in DS Tuner
DS Tuner Capability : 32
```

Check the related RCC by using the **show cable mac-domain rcc** command:

```
Router# show cable mac-domain c3/0/1 rcc
RCC-ID  RCP      RCs  MD-DS-SG  CMs  WB/RCC-TMPL      D3.0  D3.1
32 00 00 00 00 00 8 0      11  WB (Wi3/0/1:1)  Y      Y
33 00 00 00 00 00 32 0      6  WB (Wi3/0/1:3)  Y      Y
34 00 00 00 00 00 8 0      7  WB (Wi3/0/1:2)  Y Y
35 00 00 00 00 00 8 0      7  WB (Wi3/0/1:4)  Y Y
36 00 00 00 00 00 8 0      7  WB (Wi3/0/1:5)  Y Y
```

Check the dynamically created bonding groups, use the **show cable dynamic-bonding-group summary** command as shown in the example below:

```
Router# show cable dynamic-bonding-group summary
Dynamic bonding group: Enable
BG ID BG Name      BG Size  CMs  ServFlows  Create Time      Create Client      BG State
Rfid list
24834 Wi3/0/1:1 8      11  11      Sep 14 14:36:35.194 MODEM_ONLINE      OPERATIONAL
24832-24839
24836 Wi3/0/1:3 32     6    6      Sep 14 14:43:24.144 MODEM_ONLINE      OPERATIONAL
24832-24863
24835 Wi3/0/1:2 8      7    7      Sep 14 17:20:37.115 MODEM_ONLINE      OPERATIONAL
24840-24847
24837 Wi3/0/1:4 8      7    7      Sep 14 17:21:37.723 STATIC_LOAD_BALANCE OPERATIONAL
24856-24863
24838 Wi3/0/1:5 8      7    7      Sep 14 17:21:39.761 STATIC_LOAD_BALANCE OPERATIONAL
24848-24855
```

The following examples shows the DBG created with contiguous frequency channels for load balance purpose.

```
Router#show cable dynamic-bonding-group summary
Dynamic bonding group: Enable
DBG operation with Registration: Enable
DBG operation with Load-Balance: Enable
BG ID BG Name      BG Size  CMs  ServFlows  Create Time      Create Client      BG
State      Rfid list
24578 Wi3/0/0:1 24      4    4      Sep 26 15:07:22.760 MODEM_ONLINE
OPERATIONAL 24576-24599
24577 Wi3/0/0:0 8      17  17      Sep 26 16:35:01.240 MODEM_ONLINE
OPERATIONAL 24584-24591
24579 Wi3/0/0:2 8      7    7      Sep 26 16:53:48.857 DYNAMIC_LOAD_BALANCE
OPERATIONAL 24577-24584
24580 Wi3/0/0:3 8      6    6      Sep 26 16:56:49.790 DYNAMIC_LOAD_BALANCE
OPERATIONAL 24588-24595
```

```

Router#show derived-config interface wideband-Cable 3/0/0:3
Building configuration...

Derived configuration : 141 bytes
!
interface Wideband-Cable3/0/0:3
 cable bundle 255
 cable rf-channels channel-list 12-19 bandwidth-percent 1
 no snmp trap link-status
end

Router#show derived-config interface wideband-Cable 3/0/0:2
Building configuration...

Derived configuration : 139 bytes
!
interface Wideband-Cable3/0/0:2
 cable bundle 255
 cable rf-channels channel-list 1-8 bandwidth-percent 1
 no snmp trap link-status
end

```

**Table 87: Dynamic Bonding Group States**

CREATE_WAITING_SUP	Line card sends request to create DBG and waits for SUP to create the bonding group.
HOLD	DBG is created from SUP, or bonding group reverts from reclaim to ready for use.
OPERATIONAL	If modem is used on the bonding group after the HOLD state times out, the DBG state changes to OPERATIONAL.
RECLAIM_HOLD	Ready for reclaim. If no modem is used on the bonding group or match the reclaim in two minutes, the bonding group is reclaimed. The DBG state changes to RECLAIM_HOLD.
RECLAIM_MODEM_MOVING	Ready for reclaim. The modem is moved out of the bonding group.
RECLAIM_WAITING_SUP	Line card sends DBG reclaim request and waits for SUP to reclaim the BG.

To show the detailed channel list information of dynamic bonding group, use the **show derived-config interface wideband** command.

```

Router# show derived-config interface wideband-Cable 3/0/1:1
Building configuration...
Derived configuration: 113 bytes
!
interface Wideband-Cable3/0/1:1
 cable bundle 255

```

```

cable rf-channels channel-list 0-7 bandwidth-percent 1
end

```

Check the usage of bonding group resource by using the **show cable dynamic-bonding-group quota summary | slot | controller** command.

```

Router# show cable dynamic-bonding-group quota controller 3/0/1
slot/subslot/ctrlr: 3/0/1
Total BG number: 128
Used BG number (static/dynamic): 6(1/5) Available BG number: 122
Available BG list port: 0, 6-29, 31-127

```



**Note** 128 BGs can be configured on one controller, but only 896 BGs are supported per CLC. All controllers share the 896 BG resources.

Check the reclaimed bonding group by using the **show cable dynamic-bonding-group reclaim-history summary** command:

```

Router# show cable dynamic-bonding-group reclaim-history summary
BG ID BG Name      BG Size Create Time      Create Client Reclaim Time      Reclaim Client RFid
list
24835 Wi3/0/1:2 16      Sep 14 14:40:27 MODEM_ONLINE  Sep 14 14:44:27 DBG_INTERNAL
24832-2484

```

## Verifying Static Load Balancing Configuration

To verify if static load balancing is configured:

Check the load of all primary channels by using the **show cable load-balance docsis-group fn 1 md cable load | in In** command.

```

Router# show cable load-balance docsis-group fn 1 md c3/0/1 load | in In
Interface      State      Group      Utilization Rsvd NBCM WB/UB Weight
In3/0/1:0 (573 MHz) initial 2147557888 0%(0%/0%) 0% 0 17 37
In3/0/1:4 (597 MHz) initial 2147557888 0%(0%/0%) 0% 0 17 37
In3/0/1:8 (621 MHz) initial 2147557888 0%(0%/0%) 0% 0 13 37
In3/0/1:12 (645 MHz) initial 2147557888 0%(0%/0%) 0% 0 13 37
In3/0/1:16 (669 MHz) initial 2147557888 0%(0%/0%) 0% 0 13 37
In3/0/1:20 (693 MHz) initial 2147557888 0%(0%/0%) 0% 0 13 37
In3/0/1:24 (717 MHz) initial 2147557888 0%(0%/0%) 0% 0 13 37
In3/0/1:28 (741 MHz) initial 2147557888 0%(0%/0%) 0% 0 13 37

```

This command output lists all primary channels and shows the number of cable modems used with these channels. NBCM is the number of narrow band modems used with a channel while WBCM (WB/UB) is the number of wideband modems used with a channel. The total number of WBCMs should be balanced among all the channels.

The difference between the total number of WBCMs used with any two channels is smaller or equal to the threshold load minimum. The default value of the threshold load minimum is 5.

Check the load of all rf channels by using the **show cable load-balance docsis-group fn 1 md rfch-util** command.

```

Router# show cable load-balance docsis-group fn 1 md c3/0/1 rfch-util
Interface Pstate Pending-In Pending-Out Throughput(Kbps) Util NBCM WBCM
In3/0/1:0 up      No           No           0                0% 0 17

```

## Verifying Static Load Balancing Configuration

```

In3/0/1:1 NA No No 0 0% 0 17
In3/0/1:2 NA No No 0 0% 0 17
In3/0/1:3 NA No No 0 0% 0 17
In3/0/1:4 up No No 0 0% 0 17
In3/0/1:5 NA No No 0 0% 0 17
In3/0/1:6 NA No No 0 0% 0 17
In3/0/1:7 NA No No 0 0% 0 17
In3/0/1:8 up No No 0 0% 0 13
In3/0/1:9 NA No No 0 0% 0 13
In3/0/1:10 NA No No 0 0% 0 13
In3/0/1:11 NA No No 0 0% 0 13
In3/0/1:12 up No No 0 0% 0 13
In3/0/1:13 NA No No 0 0% 0 13
In3/0/1:14 NA No No 0 0% 0 13
In3/0/1:15 NA No No 0 0% 0 13
.....
Average: 0.0
Variance: 0.0

```

This command lists the load information about the primary and secondary channels. WBCM is the number of wideband modems used with a channel.

Check the cable modem's internal state in load balancing using the **show cable load-balance docsis-group fn 1 md modem-list wideband** command.

```

Router# show cable load-balance docsis-group fn 1 md c3/0/1 modem-list wideband
Codes: M - Multicast, U - UGS, P - PCMM, F - Max-Failures, X - eXcluded
      L - L2vpn, R - RSVP, S - DS-Resiliency
Primary WB   MAC Address           Primary DS   RCC-ID   Priority   MUPFXLRS State
Wi3/0/1:0   (3)
36          c8fb.2631.0e56           In3/0/1:20  41      0          ----- LB_CM_HOLD_EXPIRE_IN
37          c8fb.26a6.c3dc           In3/0/1:16  41      0          ----- LB_CM_HOLD_EXPIRE_IN
43          c8fb.2631.0d7e           In3/0/1:16  41      0          ----- LB_CM_HOLD_EXPIRE_IN
Wi3/0/1:1 (9)
           c8fb.2631.0c80           In3/0/1:0   32      0          ----- LB_CM_STATIC_MOVING
           c8fb.2631.0cae           In3/0/1:0   32      0          ----- LB_CM_STATIC_READY
           c8fb.2631.0db0           In3/0/1:24  42      0          ----- LB_CM_STATIC_MOVING
           c8fb.2631.0c10           In3/0/1:28  42      0          ----- LB_CM_STATIC_MOVING
           c8fb.2631.0d80           In3/0/1:16  41      0          ----- LB_CM_STATIC_MOVING
           c8fb.2631.0d26           In3/0/1:24  41      0          ----- LB_CM_STATIC_MOVING
           a4a2.4a2d.b4aa           In3/0/1:20  41      0          ----- LB_CM_STATIC_MOVING
           c8fb.2631.0e5c           In3/0/1:0   32      0          ----- LB_CM_STATIC_MOVING
           c8fb.2631.0cb0           In3/0/1:0   32      0          ----- LB_CM_STATIC_MOVING
Wi3/0/1:2 (3)
27          c8fb.2631.0d2a           In3/0/1:12  34      0          ----- LB_CM_HOLD_EXPIRE_IN
           c8fb.2631.0e5a           In3/0/1:12  34      0          ----- LB_CM_STATIC_MOVING
           c8fb.2631.0bfe           In3/0/1:8   34      0          ----- LB_CM_STATIC_MOVING
Wi3/0/1:3 (2)
           4800.33ea.54be           In3/0/1:28  33      0          ----- LB_CM_DYNAMIC_READY

```



```

1          4800.33ee.ebe6      In3/0/1:20  33    0    ----- LB_CM_HOLD_EXPIRE_IN
Wi3/0/1:4 (2)
40         c8fb.2631.0e44      In3/0/1:24  42    0    ----- LB_CM_HOLD_EXPIRE_IN
42         c8fb.2631.0a44      In3/0/1:28  42    0    ----- LB_CM_HOLD_EXPIRE_IN

```

**Table 88: Cable Modem States**

CM state	Description
LB_CM_STATIC_READY	Modem is ready for static load balance movement.
LB_CM_STATIC_MOVING	Modem is in movement triggered via static LB.
LB_CM_HOLD_EXPIRE_IN	Modem is in hold for the next movement. The default hold time is 600 seconds.
LB_CM_DYANMIC_READY	Modem is ready for dynamic load balance movement.
LB_CM_DYANMIC_MOVING	Modem is in movement triggered via dynamic LB.
LB_CM_DISABLED	Modem is not ready for movement. If the modem failure movement count reaches max-failure threshold, then set the modem in LB_CM_DISABLED to avoid further movement.

## Verifying Dynamic Load Balancing Configuration

Check the utilization of all rf channels by using **show cable load-balance docsis-group fn 320 md rfch-util** command.

```

Router# show cable load-balance docsis-group fn 320 md c3/0/0 rfch-util
Interface Pstate Pending-In Pending-Out Throughput (Kbps) Util NBCM WBCM
Do3/0/0:0 up No No 11754 31% 0 308
Do3/0/0:1 up No No 11754 31% 0 296
Do3/0/0:2 up No No 11754 31% 0 333
Do3/0/0:3 up No No 11754 31% 0 296
Do3/0/0:4 up No No 11754 31% 0 297
Do3/0/0:5 up No No 11754 31% 0 331
Do3/0/0:6 up No No 11754 31% 0 299
Do3/0/0:7 up No No 11753 31% 0 268
Do3/0/0:8 up No No 11754 31% 0 302
Do3/0/0:9 up No No 11754 31% 0 331
Do3/0/0:10 up No No 11753 31% 0 308
Do3/0/0:11 up No No 11754 31% 0 305
Do3/0/0:12 NA No No 12862 34% 0 258
Do3/0/0:13 NA No No 12862 34% 0 258
Do3/0/0:14 NA No No 12862 34% 0 258
.....
Average: 30.416
Variance: 1.701

```

The traffic among all rf channels is considered balanced when the difference between any two rf channel utilization is under the threshold load. The default value of threshold load is 10%.

To check the potential target bonding group for each of the source bonding group, use the **show cable load-balance docsis-group fn md cable target dbg** and the **show cable load-balance docsis-group fn md target wide** command.

```
Router# show cable load-balance docsis-group fn 320 md c3/0/0 target dbg
Interface  Bg-Id      Size      Group      Target
Wi3/0/0:0  24577      4          2147557695
Wi3/0/0:3  24580      4          2147557695
Wi3/0/0:4  24581      8          2147557695
Wi3/0/0:5  24582      8          2147557695
Wi3/0/0:6  24583      24         2147557695  33% [24576, 24584-24587, 24589-24607]
Wi3/0/0:7  24584      16         2147557695  30% [24576, 24586-24587, 24595-24607]
Wi3/0/0:8  24585      16         2147557695
Wi3/0/0:9  24586      32         2147557695
Wi3/0/0:10 24587      24         2147557695  33% [24576, 24584-24587, 24589-24607]
Wi3/0/0:11 24588      8          2147557695
Wi3/0/0:12 24589      8          2147557695  27% [24596-24603]
Wi3/0/0:13 24590      8          2147557695
Wi3/0/0:14 24591      4          2147557695
```

```
Router# show cable load-balance docsis-group fn 5 md c1/0/4 target wide
Interface  Bg-Id      State      Group      Target
Wi1/0/4:2  9219      up         2147510276  Wi1/0/4:4
Wi1/0/4:3  9220      up         2147510276
Wi1/0/4:4  9221      up         2147510276
```

If no target bonding groups are displayed, no bonding groups are created to balance traffic among rf channels.

A sample output with DOCSIS 3.1 modems with configured threshold of 14% is shown below. For utilization based load balancing to start on DOCSIS 3.1 modems, the OFDM channel must be 100% utilized and traffic must flow on SC-QAM. The utilization based load balancing balances the traffic flowing on the SC-QAM channels in a D31 modem.

```
Router# show cable load-balance docsis-group fn 5 md c1/0/4 rfch-util
Interface  Pstate Pending-In Pending-Out Throughput (Kbps) Util NBCM WBCM
In1/0/4:0  up      No          No          10632          28% 0 45
In1/0/4:1  NA      No          No          11226          29% 0 41
In1/0/4:2  NA      No          No          11225          29% 0 41
In1/0/4:3  NA      No          No          11225          29% 0 41
In1/0/4:4  down    No          No          11225          29% 0 41
In1/0/4:5  down    No          No          11225          29% 0 41
In1/0/4:6  down    No          No          11225          29% 0 41
In1/0/4:7  down    No          No          11225          29% 0 41
In1/0/4:8  up      No          No          10620          28% 0 43
.....
.....
In1/0/4:35 NA      No          No          6646           17% 0 6
In1/0/4:36 NA      No          No          6646           17% 0 6
In1/0/4:37 NA      No          No          6647           17% 0 6
In1/0/4:38 NA      No          No          6646           17% 0 6
In1/0/4:39 NA      No          No          6647           17% 0 6
In1/0/4:40 up      No          No          6088           16% 0 6
In1/0/4:41 NA      No          No          6648           17% 0 6
In1/0/4:42 NA      No          No          6647           17% 0 6
In1/0/4:43 NA      No          No          6647           17% 0 6
In1/0/4:44 NA      No          No          6646           17% 0 6
In1/0/4:45 NA      No          No          6646           17% 0 6
In1/0/4:46 NA      No          No          6647           17% 0 6
In1/0/4:47 NA      No          No          6648           17% 0 6
In1/0/4:48 NA      No          No          6648           17% 0 6
In1/0/4:49 NA      No          No          6648           17% 0 6
```

In1/0/4:50	NA	No	No	6646	17%	0	6
In1/0/4:51	NA	No	No	6648	17%	0	6
In1/0/4:52	NA	No	No	6647	17%	0	6
In1/0/4:53	NA	No	No	6648	17%	0	6
In1/0/4:54	NA	No	No	6647	17%	0	6
In1/0/4:55	NA	No	No	6648	17%	0	6
In1/0/4:56	NA	No	No	6647	17%	0	6
In1/0/4:57	NA	No	No	6647	17%	0	6
In1/0/4:58	NA	No	No	6646	17%	0	6
In1/0/4:59	NA	No	No	6645	17%	0	6
In1/0/4:60	NA	No	No	6646	17%	0	6
In1/0/4:61	NA	No	No	6646	17%	0	6
In1/0/4:62	NA	No	No	6647	17%	0	6
In1/0/4:63	NA	No	No	6647	17%	0	6
In1/0/4:159	NA	No	No	1819685	100%	0	47

## Feature Information for Dynamic Bonding Group

Use Cisco Feature Navigator to find information about the platform support and software image support. Cisco Feature Navigator enables you to determine which software images support a specific software release, feature set, or platform. To access Cisco Feature Navigator, go to the <https://cfng.cisco.com/> link. An account on the Cisco.com page is not required.



**Note** The following table lists the software release in which a given feature is introduced. Unless noted otherwise, subsequent releases of that software release train also support that feature.

**Table 89: Feature Information for Dynamic Bonding Group**

Feature Name	Releases	Feature Information
Dynamic Bonding Group	Cisco IOS XE Fuji 16.7.1	This feature was introduced on the Cisco cBR Series Converged Broadband Routers.





## CHAPTER 25

# Spectrum Management and Advanced Spectrum Management

---

This chapter describes the spectrum management features supported for the Cisco Cable Modem Termination System (CMTS) routers. Spectrum management support is divided into two main groups:

- Guided and scheduled spectrum management features (supported in software)
- Intelligent and advanced spectrum management features (supported in hardware only on specific cable interfaces)
- [Finding Feature Information, on page 441](#)
- [Hardware Compatibility Matrix for the Cisco cBR Series Routers, on page 442](#)
- [Prerequisites for Spectrum Management, on page 443](#)
- [Restrictions for Spectrum Management, on page 443](#)
- [Information About Spectrum Management, on page 445](#)
- [How to Configure Spectrum Management, on page 461](#)
- [Monitoring Spectrum Management, on page 478](#)
- [Configuration Examples, on page 484](#)
- [Additional References, on page 491](#)
- [Feature Information for Spectrum Management and Advanced Spectrum Management, on page 492](#)

## Finding Feature Information

Your software release may not support all the features that are documented in this module. For the latest feature information and caveats, see the release notes for your platform and software release. The Feature Information Table at the end of this document provides information about the documented features and lists the releases in which each feature is supported.

Use Cisco Feature Navigator to find information about platform support and Cisco software image support. To access Cisco Feature Navigator, go to <http://tools.cisco.com/ITDIT/CFN/>. An account on <http://www.cisco.com/> is not required.

# Hardware Compatibility Matrix for the Cisco cBR Series Routers



**Note** The hardware components that are introduced in a given Cisco IOS-XE Release are supported in all subsequent releases unless otherwise specified.

**Table 90: Hardware Compatibility Matrix for the Cisco cBR Series Routers**

Cisco CMTS Platform	Processor Engine	Interface Cards
Cisco cBR-8 Converged Broadband Router	<p><b>Cisco IOS-XE Release 16.5.1 and Later Releases</b></p> <p>Cisco cBR-8 Supervisor:</p> <ul style="list-style-type: none"> <li>• PID—CBR-SUP-250G</li> <li>• PID—CBR-CCAP-SUP-160G</li> </ul>	<p><b>Cisco IOS-XE Release 16.5.1 and Later Releases</b></p> <p>Cisco cBR-8 CCAP Line Cards:</p> <ul style="list-style-type: none"> <li>• PID—CBR-LC-8D30-16U30</li> <li>• PID—CBR-LC-8D31-16U30</li> <li>• PID—CBR-RF-PIC</li> <li>• PID—CBR-RF-PROT-PIC</li> <li>• PID—CBR-CCAP-LC-40G</li> <li>• PID—CBR-CCAP-LC-40G-R</li> <li>• PID—CBR-CCAP-LC-G2-R</li> <li>• PID—CBR-SUP-8X10G-PIC</li> <li>• PID—CBR-2X100G-PIC</li> </ul> <p>Digital PICs:</p> <ul style="list-style-type: none"> <li>• PID—CBR-DPIC-8X10G</li> <li>• PID—CBR-DPIC-2X100G</li> </ul> <p>Cisco cBR-8 Downstream PHY Module:</p> <ul style="list-style-type: none"> <li>• PID—CBR-D31-DS-MOD</li> </ul> <p>Cisco cBR-8 Upstream PHY Modules:</p> <ul style="list-style-type: none"> <li>• PID—CBR-D31-US-MOD</li> </ul>



---

**Note** Do not use DPICs (8X10G and 2x100G) to forward IP traffic, as it may cause buffer exhaustion, leading to line card reload.

The only allowed traffic on a DPIC interface is DEPI, UEPI, and GCP traffic from the Cisco cBR-8 router to Remote PHY devices. Other traffic such as DHCP, SSH, and UTSC should flow via another router, since DPICs cannot be used for normal routing.

---

## Prerequisites for Spectrum Management

Ensure that your network is designed to support reliable broadband data transmission. At minimum, your network must include:

- A Dynamic Host Configuration Protocol (DHCP) server to assign IP addresses to cable modems or set-top boxes on the hybrid fiber-coaxial (HFC) network. This can be a Cisco CMTS router that has been configured to act as the DHCP server.
- If you are not using cable interface line cards with integrated upconverters, you must install the appropriate IF-to-RF external upconverter between the Cisco CMTS router and the combiner.



---

**Note** The term “combiner” refers to all cables, amplifiers, and taps at the headend or cable distribution center that connect the Cisco CMTS router to the HFC network.

---

- Diplex filters installed in the downstream RF path between the cable modems and the cable interface cards in the router. RG-59 headend coaxial cable with the maximum braid available (60 percent + 40 percent braid), double foil, and the correct connector for this cable.
- Avoid frequencies with known ingress problems such as amateur radio bands or short-wave bands.
- Avoid hostile spectrums below 20 MHz.
- When designing your channel plan, allow extra bands for frequency hopping.
- Use the receive power level setting to perform slight equalization adjustments.
- Due to the nature of CATV technology, upstream noise management is a significant issue. We recommend that you follow the rigorous North American plant maintenance procedures documented in the NCTA Supplement on Upstream Transport Issues (available from the National Cable and Telecommunications Association, <https://www.ncta.com>) to adjust return amplifiers and lasers.

## Restrictions for Spectrum Management

This section describes the restrictions for the following spectrum management features:

### Shared Spectrum Groups

- Advance spectrum management does not support inter-line-card shared spectrum groups.

- Guided spectrum management does support inter-line-card shared spectrum groups.

## Dynamic Upstream Modulation

- The Cisco CMTS router has one preconfigured (primary) modulation profile that defines a typical profile for quadrature phase-shift keying (QPSK) modulation. To use the Dynamic Upstream Modulation feature, you must create a secondary modulation profile that has a higher modulation scheme than the preconfigured profile. The Three Step Dynamic Modulation feature allows you to create and use a third modulation profile. However, the third modulation profile is optional.
- Upstream modulation profiles are assigned to upstream ports and affect all cable modems on those upstream ports.
- Modulation profiles affect the physical layer of the cable network, so only trained technicians who are familiar with the Data-over-Cable Service Interface Specifications (DOCSIS) specifications should create modulation profiles.
- When using the Dynamic Upstream Modulation feature with Voice over IP (VoIP) services, frequent changes to the upstream modulation or channel width could briefly impact the quality of voice calls.

## Fixed-Frequency Spectrum Groups with Advanced Spectrum Management

Do the following to configure fixed-frequency spectrum groups:

```
Router(config)#controller upstream-cable 9/0/15
Router(config-controller)#us-channel 0 spectrum-group n
Router(config-controller)#us-channel 0 channel-width 1600000
```

## Limitations on Upstream Modulation Parameters for PacketCable VoIP Calls

We recommend the use of a channel width that is 1.6Mhz, 3.2Mhz, or 6.4Mhz while configuring upstreams for PacketCable operations and VoIP calls. (All DOCSIS channel widths and upstream parameter combinations are supported, but not optimum when offering VoIP.)

## N+1 Redundancy Support

N+1 redundancy requires the working and protect cable interface line cards to be identical. This ensures that the protect interface supports the same exact configuration as the working interface.

When protecting cards that support intelligent and advanced spectrum management, a switchover preserves the spectrum management configuration, and the protect interface initially uses the same upstream frequency as the working interface. The protect interface does not begin using the advanced spectrum management features until the system stabilizes to avoid any unnecessary frequency hops or channel width changes.

## Intelligent and Advanced Spectrum Management Support

- Cable interfaces use standard DOCSIS, EuroDOCSIS, and the extended Japanese frequency ranges (5 to 85 MHz for upstream interfaces) to support the intelligent and advanced spectrum management features.



- Intelligent and advanced spectrum management features are supported only in the DOCSIS 1.0 and DOCSIS 1.1 Time Division Multiple Access (TDMA) mode of operation. These features cannot be used when a cable interface is operating in the DOCSIS 2.0 mixed, Advanced TDMA (A-TDMA), and Synchronous Code Division Multiple Access (S-CDMA) modes of operation. Similarly, these features are also not available when the cable interface is configured to use multiple logical channels. However, these restrictions do not apply for guided spectrum management.
- Upstream channels must meet the carrier-to-noise plus interference ratio (CNI<sub>R</sub> [CNR]), and carrier-to-ingress power ratio values given in the DOCSIS specifications. The minimum value for both parameters is 25 dB in the 5 to 65 MHz frequency range.
- The intelligent and advanced spectrum management features do not support inter-line card shared spectrum groups. Spectrum management features require that upstream ports on different line cards have their own RF domain (a unique set of non-overlapping frequencies).
- N+1 redundancy is not supported on any cable interface line card that has defined spectrum groups, which typically is the normal configuration for advanced spectrum management.
- The intelligent and advanced spectrum management feature is activated by assigning spectrum groups on cards with built-in spectrum analyzer.

## Information About Spectrum Management

Spectrum management allows a Cisco Cable Modem Termination System (CMTS) to sense upstream plant impairments, report them to a management entity, and automatically correct them where possible. The spectrum management feature performs these functions without reducing throughput or latency and without creating additional packet overhead on the radio frequency (RF) plant.

In particular, because the cable interfaces on the router receive upstream packets, it can directly detect upstream transmission errors. The router can also indirectly monitor the condition of the plant by keeping a record of modem state changes, such as the number and frequency of cable modems that are “flapping” (modems that either miss a station maintenance message or that go offline and then come back online).



---

**Note** For more information about the cable modem flapping and how to monitor the cable modem flap list, see the [Flap List Troubleshooting for the Cisco CMTS Routers](#).

---

Spectrum management can prevent long-term service interruptions caused by upstream noise events in the cable plant. It is also used for fault management and troubleshooting the cable network. When cable modems are detected to go online and offline by flap detectors, the cable operators can look at the flap list and spectrum tables to determine the possible causes.

Because of the nature of cable television (CATV) technology, upstream noise management is a significant issue. Frequency bands must have a sufficient CNR (CNI<sub>R</sub>) and carrier-to-ingress power ratio to support the transmission of QPSK and quadrature amplitude modulation (QAM) data. The DOCSIS sets the minimum value for both of these ratios to 25 dB in the 5 to 65 MHz frequency range. If the CNR (CNI<sub>R</sub>) drops below 25 dB on a particular channel due to noise, the cable modem on that channel degrades and can drop off the hybrid fiber-coaxial (HFC) network.

This overview contains the following subsections:

- [Spectrum Management Measurements, on page 446](#)—Provides an overview of fundamental concepts and terms that are used in spectrum management.
- [Upstream Signal Channel Overview, on page 450](#)—Describes how signals are sent and how changes occur in upstream channels.
- [Upstream Segments and Combiner Groups, on page 451](#)—Describes sparse and dense segments and combiner groups.
- [Frequency Management Policy, on page 452](#)—Describes the types of noise impairments and how to counteract ingress noise with spectrum groups and frequency hopping.
- [Guided and Scheduled Spectrum Management, on page 454](#)—Describes the following guided and scheduled spectrum management features: frequency hopping capabilities, dynamic upstream modulation (signal-to-noise ratio-based), and input power levels.
- [Intelligent and Advanced Hardware-Based Spectrum Management, on page 459](#)—Describes spectrum management features that are supported by a number of cable interface line cards that have onboard spectrum management hardware. These features include a real-time spectrum analyzer, CNR-based, proactive frequency hopping, and a more robust dynamic upstream modulation.
- [Benefits, on page 459](#)—Describes the spectrum management features provided on the Cisco CMTS router platforms.

## Spectrum Management Measurements

Measuring the signal-to-noise ratio (SNR [MER]) and carrier-to-noise ratio (CNR [CNiR]) are the major ways of determining the quality of a downstream or upstream signal. The following sections provide an overview of these two ratios, as well as explaining the differences between them, and some additional values that might be useful:

### Signal and Carrier Noise Ratios

Measuring the Modulation Error Ratio (MER [SNR]) and CNR (CNiR) of a downstream or upstream is the first step in determining the quality of the signal, and whether spectrum management needs to be performed to correct any errors. The following are brief descriptions of these two values:

- **Modulation Error Ratio (MER [SNR])**—This is an estimate of the signal strength on the upstream after ingress noise cancellation is performed. This means that the MER (SNR) takes into account a variety of modulation impairments, including frequency response distortions (such as in-channel amplitude tilt and ripple), group delay, microreflections, and phase noise. The MER (SNR) is a good gauge of the overall end-to-end quality of the cable network, because it includes the impact that the transmitter circuitry, receiver circuitry, and transmission media have on the upstream signal.
- **Carrier-to-Noise Ratio (CNR)**—This is an ratio of the measured modulated power, in dB, on the upstream (before ingress noise cancellation is done) that compares the channel power to the noise power.

The term CNiR is part of the CableLabs nomenclature for the CNR measurement. Therefore these two terms, CNR and CNiR, can be used interchangeably.

The CNR (CNiR) measurement is usually provided only by an external spectrum analyzer, but the cable interface line cards that support intelligent and advanced hardware spectrum management features also provide CNR (CNiR) measurement.

The following two types of CNR (CNiR) measurements are supported on the Cisco CMTS:

- CNR (CNiR) measured for a particular upstream—This is the overall CNR (CNiR) for all of the cable modems on an upstream, which is determined by measuring the RF power of the upstream receiver at the cable interface. This value is always just a snapshot in time for a particular upstream. The cable interface measures the RF power at a time when no bursts are expected from the cable modems, but it can be skewed by a small number of cable modems that are experiencing or creating signal problems.
- Per-modem CNR (CNiR)—This is the CNR (CNiR) for a particular cable modem, which is signal strength of the burst transmissions of the modem at the upstream receiver of the cable interface. The per-modem CNR (CNiR) measurement is a very accurate measure of a particular cable modem's signal, but you should not use a single modem's CNR (CNiR) to make assumptions about other cable modems on that upstream or about the upstream itself. However, you can get a good picture of the upstream's signal quality by polling the CNR (CNiR) for a number of cable modems over a representative time period.



**Tip** Changing the channel width has a direct impact on the CNR (CNiR). Doubling the channel width (for example, from 400 KHz to 800 KHz) decreases the CNR (CNiR) for an upstream by approximately 3 dB. Cutting the channel width in half (for example, from 3.2 MHz to 1.6 MHz) increases the CNR (CNiR) for an upstream by approximately 3 dB.

## Differences Between the MER (SNR) and CNR (CNiR) Values

In a perfect network, such as a test lab where the only impairment is additive white Gaussian noise (AWGN), you can expect the CNR (CNiR) and MER (SNR) values to be comparable throughout all of the allowable power levels and frequency ranges. In a live network, however, it is expected that the MER (SNR) value should be a few dB lower than the CNR (CNiR) value, given that the MER (SNR) value takes into account noise impairments and distortions that are not accounted for by the CNR (CNiR) power measurements.

In general, when the CNR (CNiR) value is in the 15 to 25 dB range, you can expect the MER (SNR) value to have a comparable value. The difference between the MER (SNR) and CNR (CNiR) values is expected to be larger when the CNR (CNiR) value falls outside of the 15 to 25 dB range.

The table below provides a comparison between the MER (SNR) and CNR (CNiR) values, listing the major reasons for why the MER (SNR) and CNR (CNiR) values might diverge on an active network that is passing live traffic:

**Table 91: Comparison of MER (SNR) and CNR (CNiR) in a DOCSIS Cable Network**

Signal-to-Noise (SNR)	Carrier-to-Noise (CNR)
Post-detection measurement of the RF signal.	Pre-detection measurement of the RF signal.
Measurement of the baseband domain.	Measurement of the RF frequency domain.

Signal-to-Noise (SNR)	Carrier-to-Noise (CNR)
<p>Includes the effect of signal distortions and impairments on the signal. These include:</p> <ul style="list-style-type: none"> <li>• Group delay in the channel such as occurs during operation near the diplexer band edge.</li> <li>• Channel amplitude variation and echoes.</li> <li>• Data collisions.</li> <li>• Microreflections.</li> <li>• Narrow band ingress in the channel.</li> <li>• Non-linearities in the cable plant.</li> <li>• Phase noise.</li> <li>• Poor selection of the preamble.</li> <li>• Poor symbol fidelity in the transmission of a cable modem, despite a good MER (SNR) value.</li> <li>• Unrecoverable carrier offsets.</li> <li>• Unrecoverable symbol timing offsets.</li> </ul>	<p>Measures only the RF modulated carrier power versus noise power.</p>
<p>Provides an indication of overall, end-to-end network quality (what the transmitter, receiver, and transmission media are doing to the signal).</p>	<p>Provides an indication of network performance (what the transmission media or network is doing to the signal).</p>
<p>Average over time with current data traffic patterns, useful for tracking long-term trends in signal quality.</p>	<p>Real-time spectrum analysis.</p>
<p>Reflects the CNR (CNiR) value as part of its value.</p>	<p>Does not reflect the MER (SNR) value as part of its value.</p>
<p>Averaged over 10,000 symbols, and an accurate reading requires that short and long grants are being transferred.</p>	<p>Unaffected by the type of traffic being transmitted.</p>
<p>Does not use packets with uncorrectable FEC errors to determine its value. Bursts of uncorrectable errors, therefore, could result in a deceptively high MER (SNR) value.</p>	<p>Unaffected by uncorrectable FEC packet bursts.</p>
<p>DOCSIS specifications do not define any required MER (SNR) values for upstreams and downstreams.</p>	<p>Minimum downstream CNR of 35 dB in a 6-MHz band (44 dB in DOCSIS 2.0 for 8-MHz band)</p> <p>Minimum upstream CNR (CNiR) of 25 dB.</p>

## SNR Smoothing

Cisco cBR 16.12.1w and later, supports the following methods of easing the fluctuations in SNR:

- Cable Modem-based SNR

- US Channel-based SNR

### Cable Modem-based SNR

The SNR error (2-Bytes) is decoded by US-PHY ASIC and calculated by using the SNR formula,  $10 * \log_{10}(\text{power/error})$ . For example:

- error=7 SNR(db)=36.62db
- error=15 SNR(db)=33.22db

The MIB is docsIf3CmtsCmUsStatusSignalNoise.

Use the **cable ranging cm packet** command to configure the number of ranging packets to get the CM-based SNR.

```
Router(config)# cable ranging cm packet <1-20>
```

The number of ranging packets can be 1 to 20. The default value is 1.

### US Channel-based SNR

The SNR of a single US channel is calculated from the ranging packets of cable modems (CM) on that US channel. Cisco cBR-8 takes an average of every 10 SNR values from a CM to generate the SNR of the US channel. If a new CM SNR value is close to (within 3DB) the current US channel SNR, the Cisco cBR-8 router uses the new CM SNR to represent the current US channel SNR.

The MIB is docsIfSigQSignalNoise.

Use the **cable ranging upstream packet** command to configure the number of ranging packets to get the US channel-base SNR.

```
Router(config)# cable ranging upstream packet <10-80>
```

The default value is 10.

Use the **cable ranging upstream deviation** to configure the per upstream SNR deviation number.

```
Router(config)#cable ranging upstream deviation <1-3>
```

The default value is 3.

To display the cable ranging configuration, use the **show cable ranging setting** command. For example:

```
Router#show cable ranging setting
num_pkt_per_us: 20
num_pkt_per_cm: 5
snr_dev: 2
```

## Additional Measurements

In addition to MER (SNR) and CNR (CNI<sub>R</sub>) values, you should be aware of and monitor the following indicators of signal quality:

- MER—This is the measure of RF signal quality, in dB, which is equivalent to SNR and similar to CNR (CNI<sub>R</sub>) under additive white Gaussian noise (AWGN) impairments. However, MER is preferred for data networks, because it also includes additional factors that affect the signal, such as analog-to-digital and digital-to-analog conversions, rounding errors, distortions, and signal impairments such as phase noise,

group delay, and jitter. For this reason, the DOCSIS 2.0 RF specification adds a requirement for the minimum MER value for a signal, supplementing the existing CNR (CNiR) minimum requirements.

A simple formula for calculating the MER value for an upstream is:

$$\text{MER} = 20 \times \log (\text{RMS error magnitude} / \text{Average symbol magnitude})$$

You can also calculate the Error Vector Modulation (EVM) to find the equivalent value expressed as a percentage of noise on an upstream:

$$\text{EVM} = \text{Average error magnitude} / \text{Max symbol magnitude} * 100$$

See the DOCSIS 2.0 specification for more complete information on calculating and using the MER value.

- **FEC Counters**—These are counters that keep track of how many correctable and uncorrectable FEC errors occur on the upstream. The FEC error counters are useful for tracking fast transient errors such as impulse noise that are not usually reflected in MER (SNR) or CNR (CNiR) values.

A correctable error count of more than 1 percent can be used as a warning sign of possible physical plant or cable modem problems that might be developed. An uncorrectable error count of more than 1 percent can indicate an existing problem that is blocking traffic on the upstream. Cable interface line cards that support the intelligent and advanced spectrum management features can use the FEC counters as one of the indicators to be monitored to determine whether an upstream must change frequencies so as to correct noise problems.

- **Microreflections**—Additional copies of a signal that arrive at the receiver, usually at different times and attenuated by different amounts, causing the receiver to misidentify the incoming signal's true phase and amplitude. Microreflections typically are caused by impedance mismatches in the physical cable plant, and can indicate either equipment that has been degraded by weather or other causes, or equipment that has not been installed correctly.

## Upstream Signal Channel Overview

The upstream channel is characterized by many cable modems transmitting to the CMTS. These signals operate in a burst mode of transmission. Time in the upstream channel is slotted. The CMTS provides time slots and controls the usage for each upstream interval. The CMTS periodically broadcasts Upstream Channel Descriptor (UCD) messages to all cable modems. The UCD message contains the upstream frequency and transmission parameters associated with an upstream channel. These messages define upstream channel characteristics including the upstream frequencies, symbol rates and modulation schemes, forward error correction (FEC) parameters, and other physical layer values.

Cisco supports all DOCSIS error-correction encoding and modulation types and formats. Upstream signals are demodulated using QPSK or QAM. QPSK carries information in the phase of the signal carrier, whereas QAM uses both phase and amplitude to carry information.

Sending data reliably in the upstream direction is an issue. Because upstream spectrum varies greatly between cable plants, select upstream parameters based on your cable plant's return paths. Select or customize upstream profiles for the maximum trade-off between bandwidth efficiency and upstream channel robustness. For example, QAM-16 requires approximately 7 dB higher CNR (CNiR) to achieve the same bit error rate as QPSK, but it transfers information at twice the rate of QPSK.



---

**Note** The above specifications are based on predetermined sets of frequencies that may or may not have an adequate CNR (CNiR) at any given time.

---

Upstream frequencies can be assigned as follows:

- Fixed—Configuring a spectrum group disables the fixed upstream frequency setting.
- Single subband—The CMTS administrator can define a center frequency and symbol rate such that the boundaries of the upstream carrier stay within the subband. The frequency and symbol rate can change within the boundary in response to noisy line conditions, based on the defined upstream parameters.
- Multiple subbands—The data carrier can remain in a particular subband for a duration of time and then hop to another subband based on the defined upstream parameters.



---

**Tip** Measurement of noise power levels with a spectrum analyzer should be part of the procedure in initially selecting and setting up frequency allocations. We recommend having fixed frequency settings during early deployment, at least until amplifier cascade adjustments or plant repair have become infrequent enough that they no longer significantly affect the nodes connected to the upstream port.

---

### Upstream Frequency Changes

As stated in the DOCSIS radio frequency interface (RFI) specification, RF channel migration or upstream frequency change occurs when a change in the UCD message is broadcast to all cable interfaces.

The speed of channel migration via the UCD message is typically less than 20 milliseconds (ms). During this time, upstream transmission is interrupted until the cable interface transmitter adjusts to its new frequency. Data is stored in the cable interface buffers during this time and is sent when the frequency hop is complete.

Station maintenance intervals are used to perform per modem keepalive polling. The CMTS polls each cable modem at least once every 30 seconds, with the default being once every 20 seconds. When ingress noise causes loss of keepalive messages from a configurable percentage of all cable interfaces, resulting in missed polls, a new frequency is selected from the allocation table and a UCD update is performed. The migration time is 2 msec for any upstream UCD update. After the UCD is updated, the hop occurs. The system must wait until a hop threshold time interval has elapsed before it can change the UCD a second time.

## Upstream Segments and Combiner Groups

The Cisco routers divide a cable plant into downstream channels. Downstream channels contain upstream segments. Each upstream segment typically serves more than one fiber node. Upstream segments can be defined as one of the following:

- Sparse segment—Containing one upstream channel per upstream segment.
- Dense segment—Containing multiple upstream channels per upstream segment; frequencies must be different.



**Note** A cable interface line card can support sparse or dense segments, or both.

Defining sparse segments allows the cable operator to share upstream bandwidth among fiber nodes with fewer subscribers. Defining dense segments allows the cable operator to provide larger upstream bandwidth to fiber nodes with many subscribers.

The figure below illustrates sparse versus dense segments.

**Figure 19: Sparse Versus Dense Segment Illustrations**

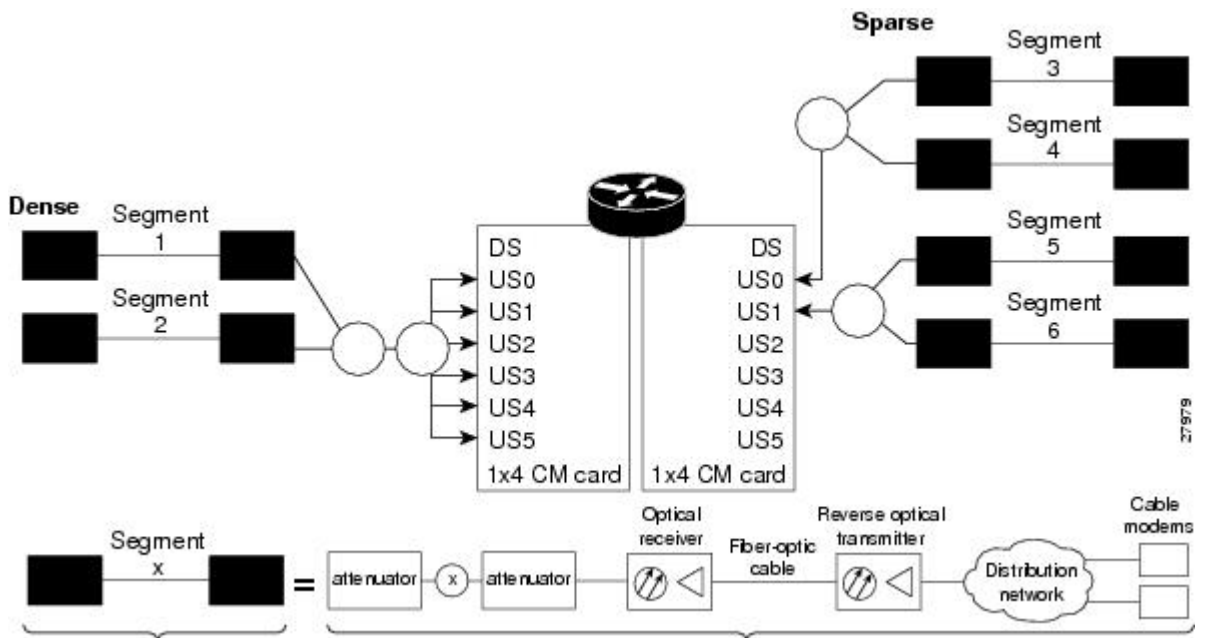

As shown in the figure above, the downstream segment can contain multiple upstream segments. Two fiber nodes can be in one downstream segment but in different upstream segments.

The return path of several fiber nodes can be combined at a single point to form a single RF frequency domain called a combiner group. The CMTS software allows a frequency hop table called a spectrum group to be associated with a combiner group.



**Note** A combiner group refers to an RF topology point. A spectrum group refers to the frequency hop table associated with a combiner group.

## Frequency Management Policy

Spectrum management applies a common frequency-management policy to a set of upstream ports to ensure that data is delivered reliably over the cable plant. Cable plant operators must make noise measurements and determine the cable plant's spectrum management policy. Different modulation schemes, upstream frequency techniques, and symbol rates are used based on the cable plant characteristics and the cable interface line card in the chassis.



See the following sections for more information about these topics:

## Noise Impairments

Upstream noise impairments such as signal degradation on cable networks can negatively affect service to subscribers. Two-way digital data signals are more susceptible than one-way signals to stresses in the condition of the HFC network. Degradation in video signal quality might not be noticeable in one-way cable TV service, but when two-way digital signals share the network with video signals, digital signals can be hampered by:

- Impulse and electrical signal ingress—Noise can enter the network from electrical sources within a residence or from high-voltage lines that run near cable television cabling. Two types of ingress noise include broadband and narrowband. Broadband noise is generally of lower frequency (below 10 MHz) and results in harmonic rolloff. Narrowband noise is a more significant interference source. Cable equipment and infrastructure often pick up noise from amateur radio transmissions, citizen band radios, or high-power shortwave broadcast signals. Implement a signal leakage maintenance program to locate and repair areas of signal ingress.
- Amplifier noise—Amplifiers add noise to the HFC network that typically goes unnoticed in video signals, but degrades digital data signals if amplifiers are improperly configured. The larger the network, the higher the probability of amplifier noise affecting signals.
- Noise funneling—The upstream data path to the headend is susceptible to interference from the entire network. All upstream noise ultimately ends up at the headend because the cumulative nature of noise becomes concentrated at the headend. As a network serviced by a single RF receiver increases in size, the probability of noise funneling also increases.
- Variable transmit levels—Temperature affects signal loss over coaxial cable. This can cause variations of 6 to 10 dB per year.
- Clipping—The lasers in fiber-optic transmitters can stop transmitting light when input levels are excessive. Excessive input levels introduce bit errors in both the upstream and downstream transmissions. If a laser is overdriven as briefly as a fraction of a second, clipping can occur.

To adjust your return amplifiers and lasers, follow rigorous plant maintenance procedures documented in the NTSC Supplement on Upstream Transport Issues or appropriate cable plant standard.

## Spectrum Groups and Frequency Hopping

We recommend that CMTS administrators configure upstream frequency hopping to counteract long-term, narrowband noise. Cisco CMTS routers support a combination of guided frequency hopping and time-scheduled frequency hopping.

The frequency hop to proactively avoid noise ingress is sometimes called frequency agility. Frequency agility is configured and activated using spectrum groups. Spectrum management supports the creation of a number of cable spectrum groups, allowing multiple upstream ports in a single spectrum group. Each spectrum group defines the table of frequencies to be used in a specific frequency plan. Upstream frequencies can be a fixed single frequency, a single continuous range of frequencies (band), or multiple ranges (or bands) of frequencies.

The cable interface does not operate until you assign a frequency to the upstream, which can be done either by configuring and assigning a spectrum group or assigning a fixed frequency. The spectrum group takes precedence, so if you configure both a spectrum group and a fixed frequency on an upstream, the spectrum group overrides the fixed upstream frequency setting.

From the interface point of view, a spectrum group also represents the set of upstreams connected to the same group of fiber nodes. The spectrum manager software in Cisco routers examines all the RF parameters that

have been configured on an upstream to determine whether the upstream frequencies need to be managed together. For example, if you configure a spectrum group with several fixed frequencies, but those frequencies are all within the configured channel width, the spectrum manager software combines the frequencies into a single band.

The upstream ports use the spectrum group to determine which frequencies are available if frequency hopping is needed to deal with noise or other path impairments. The types of frequency hopping techniques are guided, time-scheduled, and combined guided and time-scheduled. See the [Frequency Hopping Capabilities, on page 454](#) for more information on the types of frequency hopping techniques.



---

**Note** When each upstream port has its own RF domain, the group is called a nonshared spectrum group. When multiple upstream ports share the same RF domain, the group is called a shared spectrum group.

---

## Guidelines for Spectrum Management

In general, when defining your spectrum, use the following guidelines:

- Avoid frequencies with known ingress problems, such as amateur radio bands or short-wave bands.
- Avoid a hostile spectrum below 20 MHz.
- Allow extra bands for frequency hopping.
- Take the possible channel widths into account when creating frequency bands. The range of frequencies being used must be able to hop between at least two different frequencies when using the channel width that is configured on the upstream.
- Place upstream ports in the same combiner group in a shared spectrum group.
- Use the receive power level setting to perform slight equalization adjustments.
- If you combine multiple upstream ports to provide increased bandwidth, you must avoid overlapping frequency bands. Each port should be using a discrete band of frequencies that does not overlap the bands being used by other ports in the group. We recommend adding at least 20 KHz between the ending frequency of one band and the starting frequency of the next band, to ensure that the bands do not overlap.

## Guided and Scheduled Spectrum Management

Guided and scheduled spectrum management constitutes a set of basic features for all currently supported cable interface line cards. These features are considered basic because they are available for all cable interfaces, and constitute the elementary, cornerstone features upon which the intelligent and advanced spectrum management features are built.

See the following sections for more information about each feature:

### Frequency Hopping Capabilities

Noise in the upstream transmission line, that is from the consumer to the service provider, can degrade data transmission from the subscriber's home. If the noise impairment is of substantial duration, it may cause the cable modem to temporarily lose communication with the headend facility. As a contingency plan, the multiple service operators (MSOs) can reserve multiple channels or upstream frequencies for their subscribers. If one channel suffers too much interference, the CMTS requests that the cable modems "hop" to another channel.

To provide frequency hopping capability, Cisco CMTS routers contain a spectrum manager that continuously monitors the noise in unused upstream channels. If the CNR (CNiR) reaches an unacceptable level on a particular channel, the spectrum manager automatically assigns a new upstream channel to the cable modem using that channel.

Cisco CMTS routers support the following techniques for upstream frequency hopping when the frequency band in use is not clean:

- Guided frequency hopping—In guided frequency hopping (also known as blind hopping), the spectrum manager automatically assigns a new upstream channel frequency when a configurable threshold of station maintenance (keepalive) messages fails. Failed station maintenance messages represent an impairment of the upstream channel due to noise, plant, or equipment failure. Explicit frequency subbands and associated input power levels are assigned in a spectrum group in guided frequency hopping.
- Time-scheduled frequency hopping—Frequency reassignment is scheduled by the time of day or by a specific day of the week.
- Combined guided and time-scheduled frequency hopping.



---

**Note** Frequency hopping is not effective against broadband noise phenomena such as impulse noise.

---

Time-scheduled and guided hopping techniques are independent concepts:

- The spectrum is controlled by a script, not a frequency table.
- The available spectrum is time-scheduled as an option.
- A guided hopping frequency is selected from the available spectrum at the current time.

You can configure and activate frequency hopping by using spectrum groups. You can create up to 40 cable spectrum groups, each containing multiple upstream ports. The configured channel width is used for each upstream frequency.

After you have created one or more spectrum groups for your cable network, you can add characteristics to them, providing you with more definitive control over frequency usage and frequency hopping.

You can configure hopping thresholds. For example, the frequency hop threshold percentage method prevents a single failing cable modem from affecting service to other working cable modems. As long as a high enough threshold is configured, the system does not hop endlessly due to a single cable modem failing to respond to 90 percent of its station maintenance (keepalive) messages.

You can also configure the minimum period between frequency hops, with a default setting of 30 seconds. If the destination channel is expected to be impaired, you can reduce the minimum period between frequency hops to a small value, such as 10 seconds. This allows the frequency hop to continue more rapidly until a clear channel is found. If excessive frequency hop is an issue, you can increase the minimum period between hops.

To configure different techniques of frequency hopping, see the [Creating and Configuring Spectrum Groups, on page 462](#).



---

**Note** Spectrum management is not supported for one-way (telco return) cable modems, because spectrum management capabilities focus on the upstream path over an HFC network.

---



---

**Note** After the spectrum-band is changed, the spectrum management does not rearrange the frequency for each US channel if the previous frequency belongs to the range of new spectrum-band, which means that the US frequency will not be changed; if the previous frequency is out of range of new spectrum-band, those US channels will not get frequencies.

---

### Time-Scheduled Frequency Hopping

You can specify upstream channel frequency reassignment based on a configured time of every day or of a specific day of the week. If your cable plant has an upstream noise characteristic on a weekly cycle, use time-scheduled spectrum allocation. With a time-scheduled policy, a single frequency becomes valid at any given time.

## Dynamic Upstream Modulation (MER [SNR]-Based)

This section describes the operation of this feature, which is based on evaluating the MER (SNR) of an upstream.



---

**Note** A more advanced version of dynamic upstream modulation, which uses the carrier-to-noise ratio (CNR [CNiR]), is supported on the cards that support intelligent and advanced spectrum management.

---

### Feature Overview

Cisco cable interface line cards monitor the MER (SNR) values and the forward error correction (FEC) counters in the active return path of each upstream port. The Dynamic Upstream Modulation feature determines whether upstream channel signal quality can support the modulation scheme configured, and adjusts to the most robust modulation scheme when necessary. When return path conditions improve, this feature returns the upstream channel to the higher modulation scheme that includes the modulation profile.

A modulation profile is a collection of burst profiles that are sent out in a UCD message to configure modem transmit parameters for the upstream. The Dynamic Upstream Modulation feature adjusts the modulation profiles of an upstream channel based on upstream signal quality.

The Dynamic Upstream Modulation feature is configured on interfaces with fixed upstream frequencies or on interfaces with assigned spectrum groups.

The following examples show two different configurations of the Dynamic Upstream Modulation feature, using two and three modulation profiles.

#### Example Showing Dynamic Upstream Modulation Using Two Modulation Profiles

You can configure the Dynamic Upstream Modulation feature on the Cisco CMTS router using the following primary and secondary modulation profiles:

- The primary modulation profile uses 64-QAM or 16-QAM, which is a more bandwidth-efficient modulation scheme and has a higher throughput than a QPSK profile.
- The secondary modulation profile uses QPSK, which uses a more robust modulation scheme, but is not bandwidth-efficient.

We recommend that the primary profile use 64-QAM or 16-QAM modulation and the secondary use QPSK. However, this is optional as both modulation profiles can either be QPSK or QAM. It is not mandatory for one profile to be QAM and the other QPSK, but modulation profile switchover is tied to the QAM and QPSK thresholds.

### Example Showing Dynamic Upstream Modulation Using Three Modulation Profiles

You can configure the Dynamic Upstream Modulation feature on the Cisco CMTS router using the following primary, secondary, and tertiary modulation profiles:

- The primary modulation profile uses 64-QAM, which is a more bandwidth-efficient modulation scheme and has a higher throughput than a 16-QAM profile.
- The secondary modulation profile uses 16-QAM, which is a more bandwidth-efficient modulation scheme and has a higher throughput than a QPSK profile.
- The tertiary modulation profile uses QPSK, which uses a more robust modulation scheme, but is not bandwidth-efficient.

We recommend that the primary profile use 64-QAM modulation, the secondary profile use 16-QAM, and the tertiary profile uses QPSK. However, this is optional as the modulation profiles can either be QPSK or QAM. It is not mandatory that one is QPSK and the other two are QAM, but modulation profile switchover is tied to the QAM and QPSK thresholds.

### Criteria for Switching Modulation Profiles

The Dynamic Upstream Modulation feature uses the following criteria to determine whether it should switch from the primary modulation profile (the more bandwidth-efficient, but less robust profile) to the secondary modulation profile (more robust, but less bandwidth-efficient profile) or to the (optional) tertiary modulation profile (most robust, but less bandwidth-efficient profile):

The modulation switch from the primary profile (high performance) to the secondary profile (mid-level performance) uses the following criteria:

- The upstream MER (SNR) is less than or equal to MER (SNR) threshold one and the percentage of correctable FEC (cFEC) errors is greater than or equal to the correctable FEC error threshold or the percentage of uncorrectable FEC (uFEC) errors is greater than or equal to the uncorrectable FEC error threshold.

Before switching back to the primary profile from the secondary profile, the following criteria must be satisfied:

- The upstream MER (SNR) is greater than or equal to the sum of MER (SNR) threshold one and the hysteresis value and the percentage of correctable FEC errors is less than or equal to the correctable FEC error threshold and the percentage of uncorrectable FEC errors is less than or equal to the uncorrectable FEC error threshold and the hop period equals to the default value of 15 seconds.

The modulation switch from the secondary profile (mid-level performance) to the tertiary profile (most robust) uses the following criteria:

- The upstream MER (SNR) is less than or equal to MER (SNR) threshold two and the percentage of correctable FEC (cFEC) errors is greater than or equal to the correctable FEC error threshold or the percentage of uncorrectable FEC (uFEC) errors is greater than or equal to the uncorrectable FEC error threshold.

Before switching back to the secondary profile from the tertiary profile, the following criteria must be satisfied:

- The upstream MER (SNR) is greater than or equal to the sum of MER (SNR) threshold two and the hysteresis value and the percentage of correctable FEC errors is less than or equal to the correctable FEC error threshold and the percentage of uncorrectable FEC errors is less than or equal to the uncorrectable FEC error threshold.

The modulation switch from the primary profile to the tertiary profile uses the following criteria:

- The upstream MER (SNR) is less than or equal to MER (SNR) threshold two and the percentage of correctable FEC (cFEC) errors is greater than or equal to the correctable FEC error threshold or the percentage of uncorrectable FEC (uFEC) errors is greater than or equal to the uncorrectable FEC error threshold.

Before switching back to the primary profile from the tertiary profile, the following criteria must be satisfied:

- The modulation switch from the tertiary profile to the primary profile is a two-step process:
  1. The modulation switch happens from tertiary profile to the primary profile, when the upstream MER (SNR) is greater than or equal to the sum of MER (SNR) threshold one and the hysteresis value.
  2. After a 15-second (non-configurable) delay, the modulation switch occurs from secondary profile to the primary profile, when the upstream MER (SNR) remains greater than or equal to the sum of MER (SNR) threshold one and the hysteresis value.

If the only problem is that the upstream is experiencing a large number of uncorrectable errors, then a situation could occur where the router continues to switch back and forth between profiles. The uncorrectable errors occur with the primary profile, so the router switches to the secondary profile. The secondary profile does not experience any problems, so the router switches back to the primary profile. But the uncorrectable errors reoccur and the router switches back to the secondary profile, and this cycle continues indefinitely.

To avoid this problem, make sure that the cable plant is capable of supporting the modulation scheme being used in the primary profile (for example, 64-QAM). If you cannot guarantee successful operation on an upstream using this modulation scheme, then you should select a primary profile that uses a more bandwidth-efficient set of burst parameters (such as QPSK). The Cisco IOS software includes predefined modulation profiles that can be used for the primary, secondary, and tertiary profiles.

## Input Power Levels

The input power level, *power-level-dBmV*, is an option in the **cable spectrum-group** command. The option allows you to specify the expected upstream input power levels on the upstream receivers on the CMTS when the cable modems are hopping from one fixed frequency to another or from one band to another. Each upstream channel width has an associated upstream input power level in dBmV. The power level is the modem transmit power that each spectrum group can use when an upstream frequency change is necessary. The input power level may be set at the time of the frequency hop.

Specifying an input power level is done so that the cable modems do not have to increase or decrease their transmit power with every hop. The cable operator can perform minor power equalizations as a function of frequency. The valid range is -10 to 10dBmV. The power level value should be changed only if you want to change the power level as part of spectrum management. Some cable plants may want to change only the input power level, and not the frequency, on a daily time schedule.

# Intelligent and Advanced Hardware-Based Spectrum Management

Several cable interface line cards include hardware-based spectrum management features that provide enhancements to the basic features supported by the other Cisco cable interface line cards.

## Intelligent Spectrum Management Enhancements

The following features are part of the intelligent spectrum management feature set:

- Integrates a DOCSIS cable interface line card with an onboard spectrum analyzer that continuously analyzes the upstream spectrum quality in the DOCSIS frequency range of 5 to 42 MHz.
- Includes hardware-assisted frequency hopping, providing for more intelligent and faster frequency selection than software-only solutions.
- Reduces the response time to ingress noise that could cause modems to drop offline.
- Eliminates blind frequency hopping by initiating frequency hops to known clean channels.
- Improves frequency agility to help eliminate dropped packets and thereby maintain full upstream data rates.
- Supports frequency agility in dense-mode combining environments across a shared spectrum.
- Restricts frequency hopping to a set of discrete fixed frequencies or to a range of frequencies, as desired.
- Allows frequency hop conditions to be customized for specific plant environments and requirements.
- Optionally schedules frequency hops to take advantage of known usage patterns or plant conditions.
- Optionally dynamically reduces channel width to allow cable modems to remain online, even in noisy upstream conditions.

## Benefits

The spectrum management features provided on the Cisco CMTS router platforms provide several key system benefits:

- Improves response time to ingress noise impairments that appear in the upstream return path.
- Boosts the percentage of modems online.
- Mitigates the impact of ingress to subscriber services.
- Saves time and effort by MSO staff when troubleshooting minor plant outages.
- Increases cable plant reliability.
- Maximizes spectrum utilization.

## Guided and Scheduled Spectrum Management Benefits

The following summarizes the specific benefits of the guided and scheduled spectrum management features that are supported for all Cisco CMTS router platforms.

### **Input Power Levels**

Allows the cable plant operator to perform minor power level equalization as a function of frequency.

### **Frequency Hopping Capabilities**

Proactively countermeasures upstream noise impairments by assigning a new upstream channel to the cable modem. MSOs can take advantage of this feature especially when they have less than an optimal carrier-to-noise ratio in the upstream frequencies or when their cable plants exhibit random bursts of ingress noise that affect reliability.

### **Dynamic Upstream Modulation**

- Reduces the risk associated with transitioning to QAM-16 modulation in the return path and provides assurance that subscribers remain online and connected during return path impairments.
- Checks that the active upstream signal quality can support the configured modulation scheme and proactively adjusts to the more robust modulation scheme when necessary.
- Eliminates the necessity to hop channels for cable modems to stay online by automatically switching from the primary modulation profile to the secondary modulation profile.

## **Intelligent and Advanced Spectrum Management Benefits**

The following summarizes the specific benefits of the advanced spectrum management features that are supported on Cisco CMTS routers using supported cable interface line cards.

### **Dynamic Channel Width Change**

- Improves the DOCSIS upstream channel availability by finding the maximum possible channel width for an upstream when noise conditions make the current channel width unusable.
- Provides the maximum RF spectrum utilization efficiency for current plant conditions.
- Customizable range of channel widths that can be used to respond to noise problems.

### **Intelligent Frequency Hopping**

- Proactively changes upstream frequency for an interface before noise conditions become severe enough to force cable modems offline.
- Dedicated hardware intelligent frequency hopping performs “look-ahead” to choose new upstream frequency to find a stable channel.
- Flexible priority configuration allows hopping decision criteria to be tailored to the individual cable plant environment.
- Improves responsiveness to ingress impairments, by matching the hopping decision criteria to the fluctuating plant conditions.
- Pinpoints CNR (CNiR) variations with per-modem accuracy to isolate problematic cable modems.
- Sustains or even improves subscriber online percentages through user-programmable proactive channel management techniques.



### Dynamic Upstream Modulation

- Reduces the risk associated with switching between QPSK and QAM-16 modulation in the upstream to respond to ingress noise, so that subscribers remain online and connected.
- Checks the current upstream signal to ensure that it can support the configured modulation scheme, and proactively adjusts to the secondary more robust modulation scheme when necessary.
- Improves DOCSIS upstream channel availability and provides maximum RF spectrum utilization efficiency.
- Eliminates unnecessary frequency hopping by switching modulation profiles to one that allows cable modems to remain online while using the currently assigned upstream.
- Provides assurance that subscribers remain online and connected during periods of return path impairments.

### SNMP Interface

- Provides a way to remotely obtain the current status of noise on an upstream. This information can then be inserted into third-party or custom reporting and graphing applications.
- Provides visibility to ingress and impulse noise under the carrier frequency on a per-port basis.
- Provides an easy-to-use, distributed method to remotely gather real-time display of the DOCSIS upstream spectrum for individual cable modems and set-top boxes (STBs).
- Reduces the reliance on costly spectrum analyzers at every headend or hub.
- Quickly provides spectrum views through an intuitive interface, without the complicated setup time of a spectrum analyzer.
- Allows the technician to troubleshoot the network remotely, as opposed to having to be physically present to connect and use a spectrum analyzer.

### Default Hop Priority

For Intelligent and Advanced Spectrum Management feature, the default hop priority is as given below:

- Frequency, modulation, and channel width (when using spectrum groups on spectrum cards).
- Modulation, guided frequency hop, and channel width (when using analyzer cards with spectrum groups).
- Modulation only (when not using spectrum groups [fixed frequency]).

## How to Configure Spectrum Management

This section describes the configuration tasks that are most commonly performed when using the spectrum management features on the Cisco CMTS platforms. See the following sections for the configuration tasks that are appropriate for your platform and cable interface line cards.

## Guided and Scheduled Spectrum Management Configuration Tasks

The following tasks configure the guided and scheduled spectrum management features that are supported on all Cisco CMTS platforms:

### Creating and Configuring Spectrum Groups

A spectrum group defines the frequencies that an upstream is allowed to use when frequency hopping is done, as well as other parameters that control the frequency hops. When creating and configuring spectrum groups, you can specify the following parameters:

- Frequencies that are assigned to the group. The cable interface uses these frequencies to determine what frequencies are available to use when frequency hopping is needed. You can specify either a list of fixed frequencies or a band of frequencies, or both. The Cisco CMTS uses the following rules when adding frequencies to a spectrum group:
  - When specifying a fixed frequency, the Cisco CMTS assumes it is a center frequency with a 6.4-MHz channel width to allow that frequency to operate at all possible channel widths. For example, specifying a frequency of 17,700,000 Hz is equivalent to specifying a frequency band from 14,500,000 Hz to 20,900,000 Hz (a band that is 6.4 MHz wide).
  - If you configure multiple fixed frequencies or bands of frequencies that overlap, the spectrum group combines them into one band. For example, if you specify a fixed frequency of 17,700,000 Hz and a band from 15,800,000 Hz to 25,200,000 Hz, the spectrum group is configured with one band from 14,500,000 Hz to 25,200,000 Hz.
  - If you want more control over a spectrum group's frequencies, configure bands of frequencies with the same width as the desired channel width. For example, if you want to use a center frequency of 17,700,000 Hz with a 3.2-MHz channel width, specify a band that ranges from 16,100,000 Hz to 19,300,000 Hz. To ensure you configure non-overlapping bands, separate the bands by a minimum of 20 KHz.
- Upstream input power level—(Optional) Power level, in dBmV, that the upstream should use when hopping to a new frequency. (Some cable plants might want to change only the input power level, and not the frequency, on a daily time schedule.)
- Hop threshold—(Optional) Percentage of cable modems that start missing station maintenance messages before a frequency hop can occur. Configure the hop threshold percentage as needed to prevent a single failing cable interface from affecting service to other good cable interfaces. This ensures that the system does not hop endlessly because one cable modem is generating 90 percent of the errors and 90 percent of the traffic.
- Hop period—(Optional) Minimum time period that must elapse between frequency hops. This allows you to specify a time period long enough to allow an upstream to stabilize before another frequency hop can be performed.
- Scheduled hop time—(Optional) Time of day at which a frequency hop should be scheduled.



---

**Tip** Before adding a list of upstream frequencies (or frequency hop tables), start by determining which upstream ports are assigned to a combiner group. Refer to the [Example: Determining the Upstream Ports Assigned to a Combiner Group, on page 485](#) for an example.

---

To create and configure a spectrum group, use the following procedure.

### Procedure

	Command or Action	Purpose
Step 1	<b>enable</b> <b>Example:</b> Router> <b>enable</b>	Enables privileged EXEC mode. Enter your password if prompted.
Step 2	<b>configure terminal</b> <b>Example:</b> Router# <b>configure terminal</b>	Enters global configuration mode.
Step 3	<b>cable spectrum-group</b> <i>group-number</i> <b>time</b> [ <i>day hh:mm:ss</i> ] <b>frequency</b> <i>up-freq-Hz</i> [ <i>power-level-dBmV</i> ] <b>Example:</b> Router (config)# <b>cable spectrum-group 4 time Monday 12:00:00 frequency 40000000</b>	Creates the spectrum group (if it does not already exist), and adds the specified fixed frequency to the group.
Step 4	<b>cable spectrum-group</b> <i>group-number</i> <b>time</b> [ <i>day hh:mm:ss</i> ] ] <b>band</b> <i>up-freq-Hz up-freq2-Hz</i> [ <i>power-level-dBmV</i> ] <b>Example:</b> Router (config)# <b>cable spectrum-group 4 band 20000000 24000000 13</b>	Creates the spectrum group (if it does not already exist), and adds the specified band of frequencies to the group. <b>Note</b> Repeat Step 4 and Step 6 as needed for each fixed frequency and frequency band that should be a member of this spectrum group. You must assign at least two fixed frequencies, or a frequency band that contains at least two center frequencies, to a spectrum group before frequency hopping can occur.
Step 5	<b>cable spectrum-group</b> <i>group-number</i> <b>hop period</b> <i>seconds</i> <b>Example:</b> Router (config)# <b>cable spectrum-group 4 hop period 60</b>	Specifies the minimum time, in seconds, between frequency hops. <b>Note</b> We recommend a configuration of 30 seconds when using a Cisco uBR-MC5X20S/U/H BPE.
Step 6	<b>cable spectrum-group</b> <i>group-number</i> <b>hop threshold</b> [ <i>percent</i> ] <b>Example:</b> Router (config)# <b>cable spectrum-group 4 hop threshold 25</b>	Specifies the frequency hop threshold for a spectrum group. <ul style="list-style-type: none"><li>• <b>percent</b>—(Optional) Frequency hop threshold as a percentage of station maintenance messages that are lost. Valid range is from 1 to 100 percent, with a default of 50 percent.</li></ul>
Step 7	<b>cable spectrum-group</b> <i>group-number</i> <b>Example:</b> Router (config)# <b>cable spectrum-group 4</b>	(Optional) Specifies that the upstream ports in a spectrum group should use a unique upstream frequency.
Step 8	<b>end</b> <b>Example:</b>	Exits global configuration mode and returns to privileged EXEC mode.

	Command or Action	Purpose
	<code>Router(config)# end</code>	

## Assigning a Spectrum Group to One or More Upstream Ports

After a spectrum group has been created and configured, you must assign it to one or more upstream ports before the group's frequency spectrum is used for frequency hopping.

To assign a spectrum group to one or all upstream ports on a controller interface, use the following procedure.

### Procedure

	Command or Action	Purpose
<b>Step 1</b>	<code>enable</code> <b>Example:</b> <code>Router&gt; enable</code>	Enables privileged EXEC mode. Enter your password if prompted.
<b>Step 2</b>	<code>configure terminal</code> <b>Example:</b> <code>Router# configure terminal</code>	Enters global configuration mode.
<b>Step 3</b>	<code>controller upstream-cable slot/subslot/port</code> <b>Example:</b> <code>Router(config)# controller upstream-cable 9/0/15</code>	Enters controller configuration mode.
<b>Step 4</b>	<code>us-channel us -channel_num spectrum-group spectrum-group-num</code> <b>Example:</b> <code>Router(config-controller)# us-channel 0 spectrum-group 1</code>	Assigns the specified spectrum group as the default group for all upstream on this controller interface.
<b>Step 5</b>	<code>us-channel us -channel_num channel-width value</code> <b>Example:</b> <code>Router(config-controller)# us-channel 0 channel-width 1600000</code>	Configures the channel-width for the specified upstream channel spectrum group.
<b>Step 6</b>	<code>end</code> <b>Example:</b> <code>Router(config-controller)# end</code>	Exits controller interface configuration mode and returns to privileged EXEC mode.

### What to do next



**Tip** To verify the spectrum group configuration, use the **show cable spectrum-group** command in privileged EXEC mode.

## Configuring Shared Spectrum Groups (Fiber Node Groups) for DOCSIS 3.0

This feature supports shared spectrum groups that cross multiple cable interface line cards on the Cisco CMTS router, and shared spectrum groups within a single cable interface line card.

For additional information about configuring fiber node groups on the Cisco CMTS, see:

## Configuring Dynamic Upstream Modulation (MER [SNR]-Based)

To use the Dynamic Upstream Modulation feature on cable interface line cards that support only the MER (SNR) version of this feature, you must do the following:

1. Create a primary modulation profile. This typically is a more bandwidth-efficient but a less robust profile.
2. Optionally create a secondary modulation profile. This typically is a less bandwidth-efficient but a moderately robust profile.
3. Optionally create a tertiary modulation profile. This typically is a less bandwidth-efficient but a more robust profile.
4. Assign the profiles to the desired cable interfaces and upstreams.

**Tip**

When creating the modulation profiles, we recommend that you use the predefined modulation profiles, as opposed to manually specifying each burst parameter for each modulation profile.

**Restriction**

- The Dynamic Upstream Modulation feature is supported only for DOCSIS 1.0 or DOCSIS 1.1 TDMA-only modulation profiles for advanced spectrum management.
- The DOCSIS 2.0 mixed-mode or ATDMA-only mode modulation profiles are supported only for basic spectrum management (MER [SNR]-based) and not for advanced spectrum management.
- The Three Step Dynamic Modulation feature supports only basic spectrum management features. It does not support modulation profile changes based on CNR (CNiR) thresholds and CNR (CNiR) measurements.
- The Dynamic Upstream Modulation feature is not enabled for single modulation profile configurations.
- You can configure only two modulation profiles when an upstream is already assigned to a spectrum group for frequency hopping. The spectrum group here implies advanced spectrum management and/or the use of CNR (CNiR).
- A single profile is automatically removed from the configuration if three modulation profiles are assigned to an upstream interface before assigning spectrum group, based on the following conditions:
  - The robust profile is dropped if the upstream port is using a high performance profile.
  - The high performance profile is dropped if the upstream port is using a mid-level or robust profile.

## Procedure

	Command or Action	Purpose
<b>Step 1</b>	<b>enable</b> <b>Example:</b> Router> <b>enable</b>	Enables privileged EXEC mode. Enter your password if prompted.
<b>Step 2</b>	<b>configure terminal</b> <b>Example:</b> Router# <b>configure terminal</b>	Enters global configuration mode.
<b>Step 3</b>	<b>cable modulation-profile</b> <i>profile</i> { <b>mixed</b>   <b>tdma</b>   <b>atdma</b> } <b>Example:</b> Router(config)# <b>cable modulation-profile 3 mixed</b>	Creates the primary modulation profile for use on a DOCSIS 1.0 or DOCSIS 1.1 TDMA or A-TDMA upstream. <b>Note</b> Repeat this command to create the secondary and tertiary profile for use on a DOCSIS 1.0 or DOCSIS 1.1 TDMA or A-TDMA upstream. <b>Note</b> You can also create custom modulation profiles with the <b>cable modulation-profile</b> command by configuring the values for the individual burst parameters. These parameters, however, should not be modified unless you are thoroughly familiar with how changing each parameter affects the DOCSIS MAC layer. We recommend using the preconfigured default modulation profiles for most cable plants.
<b>Step 4</b>	<b>controller upstream-cable</b> <i>slot/subslot/port</i> <b>Example:</b> Router(config)# <b>controller upstream-cable 9/0/15</b>	Enters controller configuration mode.
<b>Step 5</b>	<b>us-channel</b> <i>n</i> <b>modulation-profile</b> <i>primary-profile-number</i> [ <i>secondary-profile-number</i> ] [ <i>tertiary-profile-number</i> ] <b>Example:</b> Router(config-controller)# <b>us-channel 0 modulation-profile 21 121 221</b>	Assigns a primary modulation profile, and the optional secondary and tertiary modulation profiles, to the specified upstream port.
<b>Step 6</b>	Use one of the following commands: <ul style="list-style-type: none"><li>• <b>us-channel</b> <i>n</i> <b>threshold snr-profiles</b> <i>threshold1-in-db threshold2-in-db</i></li><li>• <b>us-channel</b> <i>n m</i> <b>threshold snr-profiles</b> <i>threshold1-in-db threshold2-in-db</i></li></ul> <b>Example:</b> Router(config-controller)# <b>us-channel 0 threshold snr-profiles 25 15</b>	(Optional) Specifies the MER (SNR) threshold in dB.

	Command or Action	Purpose
Step 7	Use one of the following commands: <ul style="list-style-type: none"> <li>• <b>us-channel <i>n</i> threshold corr-fec <i>corr-fec</i></b></li> <li>• <b>us-channel <i>n m</i> threshold corr-fec <i>corr-fec</i></b></li> </ul> <b>Example:</b> <pre>Router(config-controller)# us-channel 0 threshold corr-fec 20</pre>	(Optional) Specifies the allowable number of correctable FEC errors for the upstream.
Step 8	Use one of the following commands: <ul style="list-style-type: none"> <li>• <b>us-channel <i>n</i> threshold uncorr-fec <i>uncorr-fec</i></b></li> <li>• <b>us-channel <i>n m</i> threshold uncorr-fec <i>uncorr-fec</i></b></li> </ul> <b>Example:</b> <pre>Router(config-controller)# us-channel 0 threshold uncorr-fec 10</pre>	(Optional) Specifies the allowable number of uncorrectable FEC errors for the upstream.
Step 9	<b>us-channel <i>n</i> threshold hysteresis <i>hysteresis-in-db</i></b> <b>Example:</b> <pre>Router(config-controller)# us-channel 0 threshold hysteresis 10</pre>	(Optional) Specifies the hysteresis value to be used in conjunction with the dynamic modulation upgrade thresholds.
Step 10	<b>end</b> <b>Example:</b> <pre>Router(config-controller)# end</pre>	Exits controller interface configuration mode and returns to privileged EXEC mode.

### What to do next



**Tip** See the [Dynamic Upstream Modulation \(MER \[SNR\]-Based\)](#), on page 456 for a complete description of the Dynamic Upstream Modulation feature.

## Verifying Frequency Hopping

You can verify frequency hopping on the CMTS by using the command-line interface (CLI).

### Verifying Frequency Hopping Using CLI Commands

To verify frequency hopping using CLI commands, use the following procedure:

**Step 1** Verify that the interface being tested is up, using the **show interfaces cable** command in privileged EXEC mode. The first line of the output shows whether both the interface and line protocol are up.

**Example:**

```
Router# show interfaces cable 9/0/0
```

```
Hardware is CMTS MD interface, address is c414.3c16.cf8f (bia c414.3c16.cf8f)
MTU 1500 bytes, BW 26000 Kbit/sec, DLY 1000 usec,
```

## Verifying Frequency Hopping

```
reliability 255/255, txload 1/255, rxload 1/255
Encapsulation MCNS, loopback not set
```

- Step 2** Verify that the upstream being tested is up, using the **show interfaces cable upstream** command. The first line shows whether the upstream is up.

**Example:**

```
Router# show interfaces cable 9/0/0 upstream 0

MAC domain upstream impairment report: 0x0
Cable9/0/0: Upstream 0 is up
Description: UC9/0/0:U0
Received 5 broadcasts, 0 multicasts, 26 unicasts
0 discards, 0 errors, 0 unknown protocol
31 packets input
Codewords: 348 good 0 corrected 0 uncorrectable
```

- Step 3** Use the **show cable hop upstream-cable** command to display the frequency that the upstream is currently using:

**Example:**

```
Router# show cable hop upstream-cable 9/0/0

Upstream   Port      Poll Missed Min   Missed Hop   Hop   Corr   Uncorr
Port       Status   Rate Poll  Poll  Poll  Thres Period FEC   FEC
          (ms) Count Sample Pcnt  Pcnt (sec) Errors Errors
Cable6/0/U5 16.816 Mhz 1000 0     10    0%   20%   25    0     0
```

- Step 4** Use the **show cable hop upstream-cable history** command to display the frequency change, modulation change, and channel width change action history of the upstreams:

**Example:**

```
Router# show cable hop upstream-cable 9/0/0 history

F = Frequency Hop, M = Modulation Change, C = Channel Width Change
Upstream   Action          Chg   Chg   Action
Port       Time           Code From To     Reason
Ca7/0/0/U0 Sep 17 17:00:24 C  1.6   3.2   Configuration changed
           Sep 14 19:38:55 F  41.117 26.358 Interface state changed
           Sep 14 19:38:55 F   0.000 41.117 Interface state changed
           Sep 14 19:38:24 M  21     221   Configuration changed
```

- Step 5** Use the **show cable hop upstream-cable threshold** command to display the user-defined thresholds and current CNR, MER (SNR), correctable FEC percentage, uncorrectable FEC percentage, and missed station maintenance percentage values of the upstreams:

**Example:**

```
Router# show cable hop upstream-cable 6/0/0 threshold

Upstream   SNR(dB)        CNR(dB)        CorrFEC%   UncorrFEC%   MissedSM%
Port       Val Thre1 Thre2 Val Thre1 Thre2 Pcnt Thre Pcnt Thre Pcnt Thre
Ca6/0/0/U0 27  25  15  39  35  25  0  3  0  1  75  75
Ca6/0/0/U1 31  25  15  51  35  25  0  3  0  1  90  75
```



```
Ca6/0/0/U2 -- 35 25 -- 35 25 0 3 0 1 0 75
Ca6/0/0/U3 -- 35 25 -- 35 25 0 3 0 1 0 75
```

**Step 6** Use the **test cable hop** command to force the desired upstream to perform a frequency hop. A few seconds after giving the command, a console message should appear informing you of the hop. Repeat the command as needed to verify that the upstream hops through all the frequencies that have been assigned to the upstream's spectrum group.

**Example:**

```
Router# test cable hop cable 6/0 upstream 5

2w0d: %UBR7200-5-USFREQCHG: Interface Cable6/0 Port U5, frequency changed to 15.760 MHz

Router# test cable hop cable 6/0 upstream 5

2w0d: %UBR7200-5-USFREQCHG: Interface Cable6/0 Port U5, frequency changed to 26.832 MHz
```

**Step 7** Use the **test cable channel-width** command to force the desired upstream to perform a channel-width change. A few seconds after giving the test command, use the **show cable hop** command to verify the channel-width change.

**Example:**

```
Router# test cable channel-width cable 7/0/0 upstream 0

Channel width changed to 1600000 Hz for Cable7/0/0 U0

Router# *Sep 17 17:06:46.882: %UBR10000-5-USCWCHG: Interface Cable7/0/0 U0, channel width changed to
1600 kHz SLOT 7/0: Sep 17 17:06:46.898: %UBR10000-5-USCWCHG: Interface Cable7/0/0 U0, channel width
changed to 1600 kHz

Router# Sep 17 17:06:46.898: %Interface Cable7/0/0 U0 With channel width 1600 kHz, the minislots size
is now changed to 4 ticks.

Router# show cable hop cable 7/0/0 upstream 0 history

F = Frequency Hop, M = Modulation Change, C = Channel Width Change
Upstream Action Chg Chg Action
Port Time Code From To Reason
Ca7/0/0/U0 Sep 17 17:06:46 C 3.2 1.6 Test command enforced
Sep 17 17:06:02 M 222 221 SNR 36>=28 CFEC 0<=3 UnCFEC 0<=1
Sep 17 17:06:00 M 221 222 Test command enforced
Sep 17 17:03:21 M 222 221 SNR 36>=28 CFEC 0<=3 UnCFEC 0<=1
Sep 17 17:03:19 M 221 222 Test command enforced
Sep 17 17:01:44 F 26.358 19.742 Test command enforced
Sep 17 17:01:17 F 21.528 26.358 Test command enforced
Sep 17 17:00:24 C 1.6 3.2 Configuration changed
Sep 14 19:38:55 F 41.117 21.528 Interface state changed
Sep 14 19:38:55 F 0.000 41.117 Interface state changed
Sep 14 19:38:24 M 21 221 Configuration changed

Router#
```

**Step 8** Use the **test cable freq-hop** command to force the desired upstream to perform a dynamic frequency change. A few seconds after giving the test command, use the **show cable hop** command to verify the frequency change.

**Example:**

```
Router# test cable freq-hop cable 7/0/0 upstream 0
```

```
SLOT 7/0: Sep 17 17:01:44.650: %UBR10000-5-USFREQCHG: Interface Cable7/0/0 U0, changed to Freq 19.742 MHz
```

```
Router# show cable hop cable 7/0/0 upstream 0 history
```

```
F = Frequency Hop, M = Modulation Change, C = Channel Width Change
Upstream Action Chg Chg Action
Port Time Code From To Reason
Ca7/0/0/U0 Sep 17 17:01:44 F 26.358 19.742 Test command enforced
Sep 17 17:00:24 C 1.6 3.2 Configuration changed
Sep 14 19:38:55 F 41.117 26.358 Interface state changed
Sep 14 19:38:55 F 0.000 41.117 Interface state changed
Sep 14 19:38:24 M 21 221 Configuration changed
```

**Step 9** Use the **test cable modulation-change** command to force the desired upstream to perform a dynamic modulation change. A few seconds after giving the test command, use the **show cable hop** command to verify the modulation change.

**Example:**

```
Router# test cable modulation-change cable 7/0/0 upstream 0
```

```
SLOT 7/0: Sep 17 17:03:19.038: %UBR10000-5-USMODCHANGE: Interface Cable7/0/0 U0, dynamic modulation changed to QPSK
SLOT 7/0: Sep 17 17:03:19.038: %UBR10000-6-PREAMLENADJUST: request burst's preamble length in mod profile 222 is adjusted to 38 bits.
SLOT 7/0: Sep 17 17:03:19.038: %UBR10000-6-PREAMLENADJUST: initial burst's preamble length in mod profile 222 is adjusted to 100 bits.
SLOT 7/0: Sep 17 17:03:19.038: %UBR10000-6-PREAMLENADJUST: station burst's preamble length in mod profile 222 is adjusted to 100 bits.
```

```
Router# show cable hop cable 7/0/0 upstream 0 history
```

```
F = Frequency Hop, M = Modulation Change, C = Channel Width Change
Upstream Action Chg Chg Action
Port Time Code From To Reason
Ca7/0/0/U0 Sep 17 17:03:19 M 221 222 Test command enforced
Sep 17 17:01:44 F 26.358 19.742 Test command enforced
Sep 17 17:01:17 F 21.528 26.358 Test command enforced
Sep 17 17:00:24 C 1.6 3.2 Configuration changed
Sep 14 19:38:55 F 41.117 21.528 Interface state changed
Sep 14 19:38:55 F 0.000 41.117 Interface state changed
Sep 14 19:38:24 M 21 221 Configuration changed
```

### Troubleshooting Spectrum Group Characteristics

To troubleshoot the configuration, make sure that you entered a valid spectrum group number, time, frequency, and input power level. Also, when defining your spectrum, use the following guidelines:

- Avoid frequencies with known ingress problems, such as amateur radio bands or short-wave bands.
- Avoid a hostile spectrum below 20 MHz.
- Allow extra bands for frequency hopping.
- Place upstream ports in the same combiner group in a shared spectrum group.
- Use the receive power level setting to perform slight equalization adjustments.

# Intelligent and Advanced Spectrum Management Configuration Tasks

The following sections describe the configuration tasks that are needed to configure a Cisco uBR7200 series or Cisco uBR10012 universal broadband router for the intelligent and advanced spectrum management features that are available with the Cisco cable interface line cards.

## Configuring and Assigning Spectrum Groups

You must create and configure a spectrum group before you can use the intelligent and advanced spectrum management features. These procedures are the same as those used for guided and scheduled spectrum management, which are given in the following sections:

After the spectrum groups have been configured and assigned to upstreams, the Cisco IOS software automatically uses the advanced frequency hopping algorithms on the cable interface line cards that support it.



---

**Note** For efficient use of the intelligent and advanced spectrum management features, we recommend configuring only frequency bands, and not fixed frequencies, when creating spectrum groups. A spectrum group must contain a frequency band that is wide enough for the cable interface to find at least two center frequencies at the configured channel width, before frequency hopping can occur.

---

## Configuring Dynamic Upstream Modulation (CNR-Based)

Configuring the CNR-based version of the Dynamic Upstream Modulation feature is similar to configuring the MER (SNR)-version of this feature:

1. Create a primary modulation profile. This typically is a more bandwidth-efficient but a less robust profile.
2. Create a secondary modulation profile. This typically is a less bandwidth-efficient but a more robust profile.



---

**Tip** When creating the modulation profiles, we recommend that you use the predefined modulation profiles, as opposed to manually specifying each burst parameter for each modulation profile.

---

3. Assign the profiles to the desired cable interfaces and upstreams.

After the modulation profiles have been created and assigned to upstreams, the Cisco IOS software automatically uses the advanced CNR-based version of the Dynamic Upstream Modulation feature on the cable interface line cards that support it.

**Restriction**

- The Dynamic Upstream Modulation feature is supported only for DOCSIS 1.0 or DOCSIS 1.1 TDMA-only modulation profiles. It is not supported for DOCSIS 2.0 mixed-mode or A-TDMA-only mode modulation profiles.
- Three Step Dynamic Modulation is not supported on the CNR-based version of dynamic upstream modulation.
- The CNR-based Dynamic Upstream Modulation feature does not support A-TDMA modulation profiles. However, A-TDMA is supported in the MER (SNR)-based Dynamic Upstream Modulation feature.

To assign the primary and secondary profiles to an upstream, use the following procedure.

**Procedure**

	Command or Action	Purpose
<b>Step 1</b>	<b>enable</b> <b>Example:</b> Router> <b>enable</b>	Enables privileged EXEC mode. Enter your password if prompted.
<b>Step 2</b>	<b>configure terminal</b> <b>Example:</b> Router# <b>configure terminal</b>	Enters global configuration mode.
<b>Step 3</b>	<b>cable modulation-profile</b> <i>profile</i> { <b>mix</b>   <b>qam-16</b>   <b>qpsk</b>   <b>robust-mix</b> } <b>Example:</b> Router(config)# <b>cable modulation-profile 3 mix</b>	Creates the primary modulation profile for use on a DOCSIS 1.0 or DOCSIS 1.1 TDMA upstream. Typically, the primary profile is either <b>qam-16</b> or <b>mix</b> . <b>Note</b> Repeat this command to create the secondary profile for use on a DOCSIS 1.0 or DOCSIS 1.1 TDMA upstream. Typically, the secondary profile is either <b>robust-mix</b> or <b>qpsk</b> . <b>Note</b> You can also create custom modulation profiles with the <b>cable modulation-profile</b> command by configuring the values for the individual burst parameters. These parameters, however, should not be modified unless you are thoroughly familiar with how changing each parameter affects the DOCSIS MAC layer. We recommend using the preconfigured default modulation profiles for most cable plants.
<b>Step 4</b>	<b>controller upstream-cable</b> <i>slots/subslot/port</i> <b>Example:</b> Router(config)# <b>controller upstream-cable 9/0/15</b>	Enters controller configuration mode.

	Command or Action	Purpose
Step 5	<b>cable upstream <i>n</i> modulation-profile</b> <i>primary-profile-number secondary-profile-number</i> <b>Example:</b> <pre>Router(config-controller)# cable upstream 0 modulation-profile 3 4</pre>	Assigns a primary modulation profile, and an optional secondary modulation profile, to the specified upstream port.
Step 6	<b>end</b> <b>Example:</b> <pre>Router(config-controller)# end</pre>	Exits controller interface configuration mode and returns to privileged EXEC mode.

## Configuring Proactive Channel Management

The cable interface line cards that support the advanced spectrum management features can be configured with the following parameters to fine-tune the operation of proactive channel management on the upstreams of the cards:

- Priority of the corrective actions to be taken when noise on an upstream exceeds the threshold for its modulation profile.
- CNR (CNIr) and MER (SNR) threshold and FEC values for the upstream and its two modulation profiles.
- Allowable range of channel widths that can be used if frequency hopping or modulation switching cannot avoid the upstream problems.

These parameters all have default settings, so you do not need to perform this procedure unless you want to change these parameters to better match the characteristics of your physical plant.

To configure the parameters, use the following procedure.

### Configuring Proactive Channel Management

You can configure two logical channels on a single physical port of the Cisco CMTS router. When you configure logical channels, the upstream related commands are categorized into two groups: physical port level and logical channel level.

#### Physical Port Level

Physical port level commands use the format of **cable upstream *n***, where *n* denotes the physical port number.

#### Logical Channel Level

Logical channel level commands use the format of **cable upstream *n m***, where *n* denotes the physical port number, and *m* denotes the logical channel index number of 0 or 1.

#### Procedure

	Command or Action	Purpose
Step 1	<b>enable</b> <b>Example:</b> <pre>Router&gt; enable</pre>	Enables privileged EXEC mode. Enter your password if prompted.

	Command or Action	Purpose
<b>Step 2</b>	<b>configure terminal</b> <b>Example:</b> Router# <b>configure terminal</b>	Enters global configuration mode.
<b>Step 3</b>	<b>controller upstream-cable slot/subslot/port</b> <b>Example:</b> Router (config)# <b>controller upstream-cable 9/0/0</b>	Enters controller configuration mode.
<b>Step 4</b>	<b>us-channel n hop modulation frequency channel-width</b> <b>Example:</b> Router (config-controller)# <b>us-channel 0 hop modulation frequency channel-width</b>	Specifies the priority of the three types of corrective actions ( <b>modulation</b> , <b>frequency</b> , and <b>channel-width</b> ) to be taken when the noise for the upstream exceeds the threshold specified for the current modulation profile. The default priority is <b>frequency</b> , <b>modulation</b> , and <b>channel-width</b> . <b>Note</b> The <b>channel-width</b> option must always appear after the <b>frequency</b> option.
<b>Step 5</b>	<b>cable upstream n threshold cnr-profiles threshold1-in-db threshold2-in-db</b> <b>Example:</b> Router (config-controller)# <b>cable upstream 2 threshold cnr-profiles 23 14</b>	(Optional) Specifies the CNR (CNiR) threshold and FEC values for the upstream and its two modulation profiles. <b>Note</b> To bypass both the primary and secondary CNR (CNiR) thresholds, set the first parameter ( <i>threshold1-in-db</i> ) to 0. This disallows the second parameter ( <i>threshold2-in-db</i> ), enabling you to bypass both the CNR (CNiR) thresholds.
<b>Step 6</b>	Use one of the following commands: <ul style="list-style-type: none"> <li>• <b>cable upstream n upstream threshold snr-profiles threshold1-in-db threshold2-in-db</b></li> <li>•</li> <li>• <b>cable upstream n m upstream threshold snr-profiles threshold1-in-db threshold2-in-db</b></li> <li>•</li> </ul> <b>Example:</b> Router (config-controller)# <b>cable upstream 2 threshold snr-profiles 23 14</b>	(Optional) Specifies the MER (SNR) threshold and FEC values for the upstream and its two modulation profiles. <b>Note</b> You can bypass the primary MER (SNR) threshold ( <i>threshold1-in-db</i> ) by setting it to 0. However, you must enter the second parameter ( <i>threshold2-in-db</i> ).
<b>Step 7</b>	<b>cable upstream n threshold hysteresis hysteresis-in-db</b> <b>Example:</b> Router (config-controller)# <b>cable upstream 2 threshold hysteresis 3</b>	(Optional) Specifies the hysteresis value to be used in conjunction with the dynamic modulation upgrade thresholds. <b>Note</b> You can bypass the <b>hysteresis</b> threshold by setting the value to 0.
<b>Step 8</b>	Use one of the following commands: <ul style="list-style-type: none"> <li>• <b>cable upstream n threshold corr-fec corrfec-threshold</b></li> </ul>	(Optional) Specifies the CNR (CNiR) threshold and FEC values for the upstream and its two modulation profiles.

	Command or Action	Purpose
	<ul style="list-style-type: none"> <li>• <b>cable upstream <i>n m</i> threshold corr-fec <i>corr-fec-threshold</i></b></li> </ul> <p><b>Example:</b></p> <pre>Router(config-controller)# cable upstream 5 threshold corr-fec 5</pre>	<p><b>Note</b> You can bypass the <b>corr-fec</b> threshold by setting the value to 0.</p>
<b>Step 9</b>	<p>Use one of the following commands:</p> <ul style="list-style-type: none"> <li>• <b>cable upstream <i>n</i> threshold uncorr-fec <i>uncorr-fec-threshold</i></b></li> <li>• <b>cable upstream <i>n m</i> threshold uncorr-fec <i>uncorr-fec-threshold</i></b></li> </ul> <p><b>Example:</b></p> <pre>Router(config-controller)# cable upstream 5 threshold uncorr-fec 1</pre>	<p>(Optional) Specifies the CNR (CNiR) threshold and FEC values for the upstream and its two modulation profiles.</p> <p><b>Note</b> You can bypass the <b>uncorr-fec</b> threshold by setting the value to 0.</p> <p><b>Note</b> For normal plant use, we recommend that the uncorrectable FEC threshold remain at its default of 1 percent to avoid an unacceptable number of errors on the channel.</p>
<b>Step 10</b>	<p><b>cable upstream <i>n</i> channel-width <i>first-choice-width</i> [<i>last-choice-width</i> ]</b></p> <p><b>Example:</b></p> <pre>Router(config-controller)# cable upstream 0 channel-width 800000 800000</pre>	
<b>Step 11</b>	<p><b>end</b></p> <p><b>Example:</b></p> <pre>Router(config-controller)# end</pre>	<p>Exits controller interface configuration mode and returns to privileged EXEC mode.</p>

## Verifying the Spectrum Management Configuration

Follow the steps given below to verify the spectrum management configuration.

**Step 1** To check the value of the settings you have entered, use the **show running-config** command in privileged EXEC mode:

**Example:**

```
Router# show running-config
```

**Step 2** To display the configuration for each modulation profile, use the **show cable modulation-profile** command in privileged EXEC mode:

**Example:**

```
Router# show cable modulation-profile
```

To display the configuration for a specific modulation profile, add the profile number to the **show cable modulation-profile** command in privileged EXEC mode:

**Example:**

```
Router# show cable modulation-profile 6
```

**Step 3** To display the status and configuration of each upstream, use the **show controllers cable upstream** command in privileged EXEC mode. The following example displays information for upstreams 0 on a cable line card:

**Example:**

```
Router# show controller cable 8/1/14 upstream 0
```

```
Cable8/1/14 Upstream 0 is up
  Frequency 19.504 MHz, Channel Width 3.200 MHz, Symbol Rate 2.560 Msps
  Modulations (64-QAM) - A-short 64-QAM, A-long 64-QAM, A-ugs 64-QAM
  Mapped to shared connector 18 and receiver 56
  Spectrum Group 8
  MC3Gx60 CNR measurement : 30 dB
  US phy MER(SNR)_estimate for good packets - 32.5530 dB
  Nominal Input Power Level 0 dBmV, Tx Timing Offset 1547
  Ranging Backoff Start 3, Ranging Backoff End 6
  US timing offset adjustment type 0, value 0
  Ranging Insertion Interval automatic (60 ms)
  US throttling off
  Tx Backoff Start 3, Tx Backoff End 5
  Modulation Profile Group 221
  Concatenation is enabled
  Fragmentation is enabled
  part_id=0x3142, rev_id=0xC0, rev2_id=0x00
  nb_agc_thr=0x0000, nb_agc_nom=0x0000
  Range Load Reg Size=0x58
  Request Load Reg Size=0x0E
  Minislot Size in number of Timebase Ticks is = 2
  Minislot Size in Symbols = 32
  Bandwidth Requests = 0xEE3AF
  Piggyback Requests = 0x6A24F
  Invalid BW Requests= 0x76
  Minislots Requested= 0xC33362
  Minislots Granted = 0x158609
  Minislot Size in Bytes = 24
  Map Advance (Dynamic) : 2581 usecs
  Map Count Internal = 330309891
  No MAP buffer= 0x0 No Remote MAP buffer= 0x0
  Map Counts: Controller 8/1/0 = 1321230158
  UCD Counts:
    Controller 8/1/0:0 = 336057
    Controller 8/1/0:1 = 336057
    Controller 8/1/0:2 = 336057
    Controller 8/1/0:3 = 336057

  UCD procedures on lch 0
  UCD ucd-succeeds(5) ucd-shut(0) init-state-err(0)
  UCD init-tss-err(0) init-timeout(0) init-start-err(0)
  UCD ucd-ccc-time(0) ucd-timeout(0) ucd-tss-err(0)
  UCD ucd-state-err(0) ucd-process(0) ucd-retries(0)
  UCD stale-tss(0)
  ATDMA mode enabled
  PHY: us errors 0 us recoveries 0 (enp 0)
  MAC PHY TSS: tss error start 0 tss error end 0
  MAC PHY Status: bcm3140 status 0 lookout status 0
  PHY: TSS late 0 discontinuous 0
  PHY: TSS mis-match 0 not-aligned 0
  PHY: TSS missed snapshots from phy 0
  MAP/UCD Replication Instructions:
    Controller 8/1/0 index = 477, bitmap = 0x000F
  Dynamic Services Stats:
  DSA: 0 REQs 0 RSPs 0 ACKs
  0 Successful DSAs 0 DSA Failures
  DSC: 0 REQs 0 RSPs 0 ACKs
```



```

0 Successful DSCs 0 DSC Failures
DSD: 0 REQs 0 RSPs
0 Successful DSDs 0 DSD Failures
Dropped MAC messages: (none)

```

**Step 4** To display the hop period and hop threshold values for each upstream, use the **show cable hop** command in privileged EXEC mode:

**Example:**

```
Router# show cable hop
```

Upstream Port	Port Status	Poll Rate (ms)	Missed Poll Count	Min Poll Sample	Missed Poll Pcnt	Hop Thres Pcnt	Hop Period (sec)	Corr FEC Errors	Uncorr FEC Errors
Cable3/0/U0	20.800 Mhz	105	0	20	0%	25%	45	1	4
Cable3/0/U1	20.800 Mhz	105	0	48	0%	25%	45	2	19
Cable3/0/U2	23.120 Mhz	105	0	45	0%	25%	45	0	5
Cable3/0/U3	22.832 Mhz	105	0	26	0%	25%	45	0	6
Cable3/0/U4	22.896 Mhz	105	0	43	0%	25%	45	0	7
Cable3/0/U5	23.040 Mhz	105	0	54	0%	25%	45	1	3
Cable4/0/U0	22.896 Mhz	117	0	26	0%	25%	45	0	2
Cable4/0/U1	23.168 Mhz	117	0	87	0%	25%	45	4	2
Cable4/0/U2	22.896 Mhz	117	0	23	0%	25%	45	1	0
Cable4/0/U3	20.800 Mhz	117	0	54	0%	25%	45	0	0
Cable4/0/U4	22.928 Mhz	117	0	22	0%	25%	45	0	1
Cable4/0/U5	22.960 Mhz	117	0	0	-----	25%	45	0	0

**Step 5** To display changes from one state to another, at any time and for any reason, for frequency, modulation, and channel width, use the **history** option of the **show cable hop** command.

**Example:**

```
Router# show cable hop c8/1/1 u0 history
```

```

F = Frequency Hop, M = Modulation Change, C = Channel Width Change
Upstream Action Chg Chg Action
Port Time Code From To Reason
C8/1/1 U0 Feb 20 12:21:29 M 142 141 SNR 28>=28 CFEC 0<=3 UnCFEC 0<=1
Feb 20 12:09:08 F 0.000 24.000 Configuration changed

```

**Step 6** To display thresholds for MER (SNR), CNR (CNIr), and FEC, use the **threshold** option of the **show cable hop** command.

**Example:**

```
Router# show cable hop c8/1/1 u0 threshold
```

Upstream Port	SNR (dB) Val	SNR (dB) Thre1	SNR (dB) Thre2	CNR (dB) Val	CNR (dB) Thre1	CNR (dB) Thre2	CorrFEC% Pcnt	CorrFEC% Thre	UncorrFEC% Pcnt	UncorrFEC% Thre	MissedSM% Pcnt	MissedSM% Thre
C8/1/1 u0	33	23	14	60	25	15	0	1	0	2	0	50

**Step 7** To display the assignment of each spectrum group, use the **show cable spectrum-group** command in privileged EXEC mode:

**Example:**

```
Router# show cable spectrum-group
```

Group No.	Frequency Band (MHz)	Upstream Port	Weekly Availability	Scheduled From Time:	Scheduled To Time:	Power Level (dBmV)	Shared Spectrum

```

1      42.967 [3.20] UC2/0/4:U0      -1      No
1      83.400 [3.20] UC2/0/4:U1      -1      No
1      80.200 [3.20] UC2/0/4:U2      -1      No
1      42.922 [3.20] UC2/0/4:U3      -1      No
1      17.677 [3.20] UC2/0/5:U0      -1      54
1      10.603 [3.20] UC2/0/5:U1      -1      54

```

In the above example,

- No—Fiber node is not configured
- 54—ID of the fiber node

**Step 8** To display the current CNR (CNiR) value for a particular cable modem, use the **show cable modem cnr** command in privileged EXEC mode:

**Example:**

```
Router# show cable modem 5.100.1.94 cnr
```

```

MAC Address      IP Address      I/F      MAC      Prim  snr/cnr
                State           State    Sid      (dB)
0018.689c.17b8  5.100.1.94     C7/0/0/U1  online   428   36.12

```

## Monitoring Spectrum Management

You can either use Cisco CLI commands or SNMP to monitor spectrum management activity on the Cisco CMTS.

See the following sections for more information:

### Using CLI Commands

The following commands provide information on the spectrum condition of an upstream:

Command	Purpose
Router# <b>show cable hop</b> [ <b>cable</b> x/y] [ <b>upstream</b> usport]	Displays the hop period and hop threshold values, as well as the FEC error counters, for all upstreams in the router, all upstreams on one cable interface line card, or a single upstream.
Router# <b>show cable hop</b> [ <b>cable</b> x/y[z]] [ <b>upstream</b> n] [ <b>thresholds</b> ]	Displays the configured and current value of MER (SNR) in dB, CNR (CNiR) in dB, CorrFEC in percentage, UncorrFEC in percentage, and missed station maintenance in percentage for a specified upstream.

Command	Purpose
Router# <b>show cable hop history</b>	<ol style="list-style-type: none"> <li>1. With the <b>show cable hop history</b> command for entire CMTS, the most recent change of each action is displayed.</li> <li>2. With the <b>show cable hop history</b> command for a MAC domain, the most recent three changes of each action are displayed.</li> <li>3. With the <b>show cable hop history</b> command for a specific upstream, the last ten changes of each action are displayed. Changes are sorted by time with the most recent at the top.</li> </ol>
Router# <b>show cable hop</b> [cable x/y[z]] [upstream n] [summary]	Displays hourly, daily, weekly, 30 days running average, and average since the system was brought up for each specified upstream.
Router# <b>show cable hop</b> [cable x/y[z]] [upstream n] [history]	Displays changes from one state to another, at any time and for any reason, for frequency, modulation, and channel width.
Router# <b>show cable modem</b> [ip-address   interface   mac-address] [options]	Displays information, including MER (SNR) values, for the registered and unregistered cable modems.
Router# <b>show cable modulation-profile</b> [num] [initial   long   reqdata   request   short   station]	Displays the configuration for all modulation profiles, for a particular modulation profile, or for a specific burst type for a particular modulation profile.
Router# <b>show cable spectrum-group</b> [groupnum] [detail]	Displays information about the spectrum groups that have been configured.
Router# <b>show controllers cable</b> x/y upstream n [ip-address   mac-address] start-freq end-freq res-freq	Displays the upstream status, including the current frequency, channel width, modulation rate, and spectrum groups.
Router# <b>show controllers cable</b> x/y upstream n spectrum [ip-address   mac-address] start-freq end-freq res-freq	Displays the noise levels for a particular cable modem or displays the background noise for an entire upstream.



**Note** The **show cable flap-list** command displays the flap list of the CMTS router, which provides additional information about whether cable modems on an upstream are experiencing problems, and if so, what type of problems are occurring. For more information about the cable modem flapping and how to monitor the cable modem flap list, see the [Flap List Troubleshooting for the Cisco CMTS Routers](#).

## Using SNMP

You can use SNMP to monitor the spectrum management activity. The SNMP manager can be a graphically-based SNMP manager such as CiscoView or the Cable Broadband Troubleshooter (Release 3.0 or later).

The CISCO-CABLE-SPECTRUM-MIB has been enhanced to provide this SNMP support using the following MIB attributes:

## ccsSNRRequestTable

The table below lists the attributes in the ccsSNRRequestTable table, which contains the CNR (CNiR) measurements that are made for individual cable modems on an upstream.

**Table 92: ccsSNRRequestTable Attributes**

Attribute	Type	Description
ccsSNRRequestIndex	Integer32	Arbitrary index to uniquely identify each table entry.
ccsSNRRequestMacAddr	MacAddress	MAC address of the remote online cable modem being reported on.
ccsSNRRequestSNR	Integer32	MER (SNR) value, in dB, that has been measured. This value is 0 when the Operation State is "running."
ccsSNRRequestOperation	CCSRequestOperation	Sets the current operation: start, pending, running, or cancel.
ccsSNRRequestOperState	CCSRequestOperState	Reports on the current operation state: idle, pending, running, noError, canceled, notOnLine, invalidMac, timeOut, fftBusy, fftFailed, others.
ccsSNRRequestStartTime	TimeStamp	Contains the time when the MER (SNR) measurement operation starts.
ccsSNRRequestStoppedTime	TimeStamp	Contains the time when the MER (SNR) measurement stops.
ccsSNRRequestStatus	RowStatus	Controls the modification, creation, and deletion of table entries.

## ccsSpectrumRequestTable

The table below lists the attributes for each entry in the ccsSpectrumRequestTable table, which is used to obtain the spectrum profile for a particular cable modem or to obtain the background MER (SNR) for an entire upstream.

**Table 93: ccsSpectrumRequestTable Attributes**

Attribute	Type	Description
ccsSpectrumRequestIndex	Integer32	Arbitrary index to uniquely identify each table entry.
ccsSpectrumRequestIfIndex	InterfaceIndexOrZero	Interface identifying the upstream.
ccsSpectrumRequestMacAddr	MacAddress	MAC address to specify an MER (SNR) value for a particular cable modem, or 0000.0000.0000 to indicate background noise for the entire spectrum.

Attribute	Type	Description
ccsSpectrumRequestUpperFreq	CCSFrequency	Upper frequency for the frequency range to be monitored (5000 to 42000 KHz, with a default of 42000 KHz).
ccsSpectrumRequestLowFreq	CCSFrequency	Lower frequency (in KHz) for the frequency range to be monitored (5000 to 42000 KHz, with a default of 5000 KHz).
ccsSpectrumRequestResolution	Integer32	Requested resolution to determine how the frequency range should be sampled (12 to 37000 KHz, with a default of 60 KHz).
ccsSpectrumRequestStartTime	TimeStamp	Time when the spectrum measurement began.
ccsSpectrumRequestStoppedTime	TimeStamp	Time when the spectrum measurement finished.
ccsSpectrumRequestOperation	CCSRequestOperation	Starts a new spectrum management request or cancels the current one.
ccsSpectrumRequestOperState	CCSRequestOperState	Provides the operational state of the current spectrum management request.
ccsSpectrumRequestStatus	RowStatus	Controls the modification, creation, and deletion of table entries.

## ccsSpectrumDataTable

The table below lists the attributes in each entry of the ccsSpectrumDataTable table, which contains the results for a spectrum request.

*Table 94: ccsSpectrumDataTable Attributes*

Attribute	Type	Description
ccsSpectrumDataFreq	CCSMeasuredFrequency	Frequency in KHz for which this power measurement was made.
ccsSpectrumDataPower	INTEGER	Measured received power for the given frequency (-50 to 50 dBmV).



**Note** The ccsSpectrumRequestTable and ccsSpectrumDataTable tables provide the same information as that provided by the **show controllers cable upstream spectrum** command.

## ccsUpSpecMgmtTable

The table below lists the attributes in the ccsUpSpecMgmtTable table, which provides an entry describing each frequency hop.

Table 95: ccsUpSpecMgmtEntry Attributes

Attribute	Type	Description
ccsUpSpecMgmtHopPriority	INTEGER	Specifies the priority of frequency, modulation profile, and channel width in determining corrective action for excessive noise on the upstream (default is frequency, modulation profile, and channel width).
ccsUpSpecMgmtSnrThres1	Integer32	Specifies the upper MER (SNR) threshold for modulation profile 1 (5 to 35 dB, default of 25).
ccsUpSpecMgmtSnrThres2	Integer32	Specifies the upper MER (SNR) threshold for modulation profile 2 (5 to 35 dB, default of 13, and must be lower than that specified for ccsUpSpecMgmtSnrThres1).
ccsUpSpecMgmtFecCorrectThres1	Integer32	Specifies the FEC correctable error threshold for modulation profile 1 (1 to 20 percent)
ccsUpSpecMgmtFecCorrectThres2	Integer32	Zero (0). Deprecated and no longer used.
ccsUpSpecMgmtFecUnCorrectThres1	Integer32	Specifies the FEC uncorrectable error threshold for modulation profile 1 (1 to 20 percent).
ccsUpSpecMgmtFecUnCorrectThres2	Integer32	Deprecated and no longer used.
ccsUpSpecMgmtSnrPollPeriod	Integer32	Deprecated and no longer used.
ccsUpSpecMgmtHopCondition	INTEGER	Reports the condition that triggers a frequency hop (MER [SNR] value or percentage of modems going offline).
ccsUpSpecMgmtFromCenterFreq	CCSFrequency	Provides the center frequency (in KHz) before the latest frequency hop.
ccsUpSpecMgmtToCenterFreq	CCSFrequency	Provides the current center frequency (in KHz) after the latest frequency hop.
ccsUpSpecMgmtFromBandWidth	CCSFrequency	Provides the channel width (in KHz) before the latest frequency hop.
ccsUpSpecMgmtToBandWidth	CCSFrequency	Provides the current channel width (in KHz) after the latest frequency hop.
ccsUpSpecMgmtFromModProfile	Integer32	Provides the modulation profile number before the latest frequency hop.

Attribute	Type	Description
ccsUpSpecMgmtToModProfile	Integer32	Provides the current modulation profile number after the latest frequency hop.
ccsUpSpecMgmtSNR	Integer32	Provides the current MER (SNR) value (in dB) for the upstream.
ccsUpSpecMgmtCnrThres1	Integer32	Specifies the upper CNR (CNiR) threshold for modulation profile 1 (5 to 35 dB, default of 25).
ccsUpSpecMgmtCnrThres2	Integer32	Specifies the upper CNR (CNiR) threshold for modulation profile 2 (5 to 35 dB, default of 13, and must be lower than that specified for ccsUpSpecMgmtCnrThres1).
ccsUpSpecMgmtCNR	Integer32	Provides the current CNR (CNiR) value (in dB) for the upstream.
ccsUpSpecMgmtMissdMaintMsgThres	Integer32	Provides the frequency hop threshold, as a percentage of station maintenance messages that are lost for a spectrum group.
ccsUpSpecMgmtHopPeriod	Integer32	Provide the minimum time, in seconds, between frequency hops.

## ccsHoppingNotification

The table below describes the attributes contained in the notification that is sent after each frequency hop.

**Table 96: ccsHoppingNotification Attributes**

Attribute	Type	Description
ccsUpSpecMgmtHopCondition	INTEGER	Reports the condition that triggers a frequency hop (MER [SNR] value or percentage of modems going offline).
ccsUpSpecMgmtFromCenterFreq	CCSFrequency	Provides the center frequency (in KHz) before the latest frequency hop.
ccsUpSpecMgmtToCenterFreq	CCSFrequency	Provides the current center frequency (in KHz) after the latest frequency hop.
ccsUpSpecMgmtFromBandWidth	CCSFrequency	Provides the channel width (in KHz) before the latest frequency hop.
ccsUpSpecMgmtToBandWidth	CCSFrequency	Provides the current channel width (in KHz) after the latest frequency hop.
ccsUpSpecMgmtFromModProfile	Integer32	Provides the modulation profile number before the latest frequency hop.

Attribute	Type	Description
ccsUpSpecMgmtToModProfile	Integer32	Provides the current modulation profile number after the latest frequency hop.

## Configuration Examples

This section provides the following configuration examples:

### Spectrum Group and Combiner Group Examples

The following examples help you to determine whether spectrum group and combiner groups are configured and activated.

#### Example: Verifying Spectrum Group Creation

To verify that a spectrum group has been created, enter the **show cable spectrum-group** command:

```
Router# show cable spectrum-group
spectrum-group 1
spectrum-group 2
spectrum-group 3
```

#### Example: Time-Scheduled Spectrum Group

If your cable plant has an upstream noise characteristic on a weekly cycle, use time-scheduled spectrum allocation.

```
Router(config)# cable spectrum-group 1 time Mon 08:00:00 frequency 21600000
```

Deletion is performed using the **delete** keyword:

```
Router(config)# cable spectrum-group 1 time Mon 18:00:00 delete frequency 21600000
```

#### Example: Verifying Spectrum Group Configuration

To verify if spectrum groups have been configured and activated, enter the **show cable spectrum-group** command. This command displays each spectrum group, the frequencies assigned to it, the upstream port to which it has been assigned, whether a schedule exists for it, the currently measured power level, and whether it is a shared spectrum group.

```
Router# show cable spectrum-group

22:07:46: %SYS-5-CONFIG_I: Configured from console by console
Group  Frequency      Upstream      Weekly Scheduled      Power  Shared
No.    Band              Port          Availability          Level  Spectrum
      (Mhz)
1      5.000-15.000
1      12.000
1      22.000           Cable6/0 U5      From Time:           To Time:           7      Yes
2      29.000           Cable6/0 U4      6      No
2      26.000           0                No
3      35.000-41.000
3      16.000-19.000   Cable6/0 U3      5      No
5*     5.000-10.000           Thu 21:50:00   Thu 21:45:00   0      Yes
```



## Example: Determining the Upstream Ports Assigned to a Combiner Group

Following is a sample topology for a CMTS with combiner groups designated A through J. Combiner groups C and E have multiple upstream ports that should be configured in a shared spectrum group. The other upstreams should be configured in a nonshared spectrum group.

In this example, ten combiner groups are served with frequency hop tables from three spectrum groups:

```
Cable3/0
DS +-----+ Upconverter +----- laser group 1
U0 +----- combiner group A
U1 +----- combiner group B
U2 +-----combiner group C
U3 +-----combiner group C
U4 +----- combiner group D
U5 +-----combiner group E
Cable4/0
DS +-----+ Upconverter +----- laser group 2
U0 +-----combiner group E
U1 +----- combiner group F
U2 +----- combiner group G
U3 +----- combiner group H
U4 +----- combiner group I
U5 +----- combiner group J
```

The *laser group* term refers to the set of fiber nodes that share the same downstream signal. An optical splitter is often used to create individual feeds per node.

In the downstream direction, two 6-MHz channel slots are assigned. All fiber nodes in combiner groups A through E should have a channel slot containing the downstream signal from Cable3/0. Combiner groups A through E are said to belong to laser group 1.

All fiber nodes in combiner groups E through J should have a channel slot containing the downstream signal from Cable4/0. Combiner groups E through J are said to belong to laser group 2.

Because combiner group E belongs to two laser groups, there should be two different downstream channel slots for Cable3/0 and Cable4/0.

## Example: Combiner Group

The following example enables spectrum management for all upstream ports, where all combiner groups use the frequency band from 20 to 26 MHz:

```
CMTS01(config)# cable spectrum-group 1 band 20000000 26000000
CMTS01(config)# cable spectrum-group 2 shared
CMTS01(config)# cable spectrum-group 2 band 20000000 26000000
CMTS01(config)# cable spectrum-group 3 shared
CMTS01(config)# cable spectrum-group 3 band 20000000 26000000
CMTS01(config)# controller upstream-Cable 9/0/0
CMTS01(config-controller)# cable spectrum-group 1
CMTS01(config-controller)# cable upstream 2 spectrum-group 2
CMTS01(config-controller)# cable upstream 3 spectrum-group 2
CMTS01(config-controller)# cable upstream 5 spectrum-group 3
CMTS01(config-controller)# exit
CMTS01(config)# controller upstream-Cable 9/0/1
CMTS01(config-controller)# cable spectrum-group 1
CMTS01(config-controller)# cable upstream 0 spectrum-group 3
```

A description of the spectrum groups 1 through 3 follows:

- Spectrum group 1—This group is nonshared. Upstream RF domains exist for each member upstream port.

Upstream Port	RF Domain
Cable3/0 U0	combiner group A
Cable3/0 U1	combiner group B
Cable3/0 U4	combiner group D
Cable4/0 U1	combiner group F
Cable4/0 U2	combiner group G
Cable4/0 U3	combiner group H
Cable4/0 U4	combiner group I
Cable4/0 U5	combiner group J

- Spectrum group 2—This group is shared. A single upstream RF domain exists.

Upstream Port	RF Domain
Cable3/0 U2	combiner group C
Cable3/0 U3	combiner group C

- Spectrum group 3—This group is shared. A single upstream RF domain exists.

Upstream Port	RF Domain
Cable3/0 U5	combiner group E
Cable4/0 U0	combiner group E

For the 20- to 26-MHz band of each RF domain, the spectrum is channelized according to the channel width settings of each member port. For example, if the ports U2 and U3 of Cable3/0 are set to 3.2 MHz and 1.6 MHz channel widths, respectively, then spectrum group 2 uses the following channelization:

```
> Channel Width Start Stop Center
>          (Mhz) (Mhz) (Mhz) (Mhz)
> 1         3.2   20.0 23.2 21.6
> 2*        1.6   20.0 21.6 20.8
> 3*        1.6   21.6 23.2 22.4
> 4         1.6   23.2 24.8 24.0
```



---

**Note** Channels 2 and 3 are not available when channel 1 is in use.

---

Because the group is shared, ports U2 and U3 will be assigned channels 1 and 4, respectively, to prevent overlap.



---

**Note** There are no alternate frequency assignments for either port, and bandwidth is wasted from 24.8 to 26.0 MHz. To create alternate channels, increase the upper boundary from 26.0 to 28.0 MHz.

---

```
> Channel Width Start Stop Center
>          (Mhz) (Mhz) (Mhz) (Mhz)
> 1         3.2   20.0 23.2 21.6
> 2         3.2   23.2 26.4 24.8
> 3         1.6   20.0 21.6 20.8
> 4         1.6   21.6 23.2 22.4
> 5         1.6   23.2 24.8 24.0
> 6         1.6   24.8 26.4 25.6
```

```
> 7          1.6    26.4  28.0  27.4
```

Try to reduce the spectrum allocation when it is used with small channel widths. Otherwise, there will be a large number of upstream channel slots, and the frequency hopping may require several minutes to find a clean slot.

## Example: Other Spectrum Management Configurations

To configure differing spectrum groups, refer to the following examples:

- Use the following example to configure spectrum group 3 with an upstream band of 12,000,000 to 18,000,000 Hz and default power level of 0 dBmV:

```
Router(config)# cable spectrum-group 3 band 12000000 18000000
```

- Use the following example to add the upstream band 20,000,000 to 24,000,000 Hz to the list of valid bands with a change in the power level of 13 dBmV for spectrum group 3:

```
Router(config)# cable spectrum-group 3 band 20000000 24000000 13
```

- Use the following example to configure a continuous band between 5,000,004 and 40,000,000 Hz for scheduled spectrum group 4 with a default power level of 0 dBmV. The band is available to the spectrum group starting at 12:00 p.m. local time each Monday:

```
Router(config)# cable spectrum-group 4 time Monday 12:00:00 band 5000004 40000000
```

- Use the following example to add the upstream frequency 9,500,000 Hz to the list of valid frequencies and change the nominal power level to 5 dBmV. The spectrum manager adjusts frequencies and power levels on this group at 2:00 a.m. local time each day:

```
Router(config)# cable spectrum-group 3 time 02:00:00 frequency 9500000 5
```

- Use the following example to configure the minimum period before which a frequency hop can occur in seconds:

```
Router(config)# cable spectrum-group 3 hop period 800
```

- Use the following example to configure the threshold value (expressed as a percentage) of the number of “offline” modems identified before the router initiates an automatic frequency hop:

```
Router(config)# cable spectrum-group 3 hop threshold 40
```

- Use the following example to configure a particular spectrum group as a shared RF spectrum group. Specifying a given spectrum group as “shared” tells the router that you want to be sure that upstream frequencies assigned to upstream ports are not assigned to additional upstream ports:

```
Router(config)# cable spectrum-group 3 shared
```

- Use the following example to remove a specified spectrum group from your configuration:

```
Router(config)# no cable spectrum-group 3
```

## Dynamic Upstream Modulation Examples

The following examples describe how to display modulation profile information with the **show cable modulation-profile** command and to define a modulation profile with the **cable modulation-profile** command.

### Verifying Your Settings

**Step 1** To check the value of the settings you have entered, enter the **show running-config** command in privileged EXEC mode:

**Example:**

```
Router# show running-config
```

To review changes you make to the configuration, use the **show startup-config** command in privileged EXEC mode to display the information stored in NVRAM.

**Step 2** To display modulation profile group information, use the **show cable modulation-profile** command in privileged EXEC mode:

**Example:**

```
Router# show cable modulation-profile [profile] [iuc-code]
```

This command uses the following syntax:

- *profile*—(Optional) Profile number. Valid values are from 1 to 8.
- *iuc-code*—(Optional) Internal usage code.

Valid options are:

- **initial**—Initial ranging burst
- **long**—Long grant burst
- **request**—Request burst
- **short**—Short grant burst
- **station**—Station ranging burst

### Example: Modulation Profiles

The Cisco CMTS has one preconfigured modulation profile resident in memory, which defines a typical profile for QPSK modulation. To use the Dynamic Upstream Modulation feature, a second profile must be created that is unique from the first profile, and typically provides a higher, more robust modulation scheme.

The following example is a modulation profile for QAM-16, in which the initial, request, and station maintenance messages are sent as QPSK, and the short and long data packets are sent as QAM-16. The QAM-16 modulation is more bandwidth-efficient than QPSK, but QPSK is more robust than QAM-16.



**Note** The upstream request and station maintenance messages use less time on the cable network when configured in QPSK for symbol rates of 640K, 1280K, and 2560K symbols/sec. Thus, these messages are actually more efficient when used in QPSK mode and they ensure a more reliable modem connection. The upstream initial maintenance message takes exactly the same amount of time on the cable network, no matter how it is configured. Modems connect more quickly and experience fewer cycles of power adjustment during initial maintenance if the system is set for QPSK.

```
Router# configure terminal
Router(config)# cable modulation-profile 2 request 0 16 1 8 qpsk scrambler 152 no-diff 64
fixed uw16
Router(config)# cable modulation-profile 2 initial 5 34 0 48 qpsk scrambler 152 no-diff 128
fixed uw16
Router(config)# cable modulation-profile 2 station 5 34 0 48 qpsk scrambler 152 no-diff 128
fixed uw16
Router(config)# cable modulation-profile 2 short 6 75 6 8 16qam scrambler 152 no-diff 72
fixed uw16
Router(config)# cable modulation-profile 2 long 8 220 0 8 16qam scrambler 152 no-diff 160
fixed uw16
```

In the following example, all message types are carried with QAM-16 modulation. Although QAM-16 modulation offers a consistent modulation scheme for all five types of messages, the added length of the QAM-16 preamble offsets the increased bandwidth efficiency of the MAC data message for the station maintenance messages and bandwidth request messages.

```
Router# configure terminal
Router(config)# cable modulation-profile 2 request 0 16 1 8 16qam scrambler 152 no-diff 128
fixed uw16
Router(config)# cable modulation-profile 2 initial 5 34 0 48 16qam scrambler 152 no-diff
256 fixed uw16
Router(config)# cable modulation-profile 2 station 5 34 0 48 16qam scrambler 152 no-diff
256 fixed uw16
Router(config)# cable modulation-profile 2 short 5 75 6 8 16qam scrambler 152 no-diff 144
fixed uw16
Router(config)# cable modulation-profile 2 long 8 220 0 8 16qam scrambler 152 no-diff 160
fixed uw16
```



**Note** When using DOCSIS concatenation with a 16-QAM or mixed symbol rate, configure the CMTS for Unique Word 16 (“uw16”) in the preamble for both short and long data burst profiles.

Add the **cable upstream port-number modulation-profile primary profile-number secondary profile-number** command to the appropriate interfaces. In this example, modulation profile 2 is for QAM-16 modulation and profile 1 is for QPSK modulation.

```
Router# configure terminal
Router(config)# controller upstream-Cable 6/0/0
Router(config-controller)# cable upstream 0 modulation-profile 2 1
```

## Example: Input Power Level

In the following example, the modem transmit power at 24.8 MHz is adjusted upstream by 1 dBmV and the modem transmit power at 28.0 MHz is adjusted upstream by 2 dBmV.

```
CMTS01(config)# cable spectrum-group 1 frequency 21600000
CMTS01(config)# cable spectrum-group 1 frequency 24800000 1
CMTS01(config)# cable spectrum-group 1 frequency 28000000 2
```

## Advanced Spectrum Management Configuration Examples

This section provides the following typical configurations:

### Example: Advanced Spectrum Management for the Cisco cBR Series Routers

This section provides an excerpt from a typical configuration example for a Cisco cBR Series router using a cable interface line card. This configuration does the following:

- Configures four spectrum groups with a hop period of 30 seconds.
- Creates a QPSK modulation profile and assigns it to four upstreams on the Cisco cable interface line card in slot 6/1/0.
- Assigns a spectrum group to each of the four upstreams.
- Configures each upstream for the default CNR (CNiR) and FEC thresholds.

```
cable modulation-profile 21 qpsk
interface Cable6/1/0
cable bundle 1
cable downstream annex B
cable downstream modulation 256qam
cable downstream interleave-depth 32
! upstream 0
cable upstream 0 spectrum-group 1
cable upstream 0 modulation-profile 21
cable upstream 0 threshold cnr-profiles 16 0
cable upstream 0 threshold Corr-Fec 3
cable upstream 0 threshold Uncorr-Fec 1
no cable upstream 0 shutdown ! upstream 1
cable upstream 1 spectrum-group 2
cable upstream 1 modulation-profile 21
cable upstream 1 threshold cnr-profiles 16 0
cable upstream 1 threshold Corr-Fec 3
cable upstream 1 threshold Uncorr-Fec 1
no cable upstream 1 shutdown ! upstream 2
cable upstream 2 spectrum-group 3
cable upstream 2 modulation-profile 21
cable upstream 2 threshold cnr-profiles 16 0
cable upstream 2 threshold Corr-Fec 3
cable upstream 2 threshold Uncorr-Fec 1
no cable upstream 2 shutdown ! upstream 3
cable upstream 3 spectrum-group 4
cable upstream 3 modulation-profile 21
cable upstream 3 threshold cnr-profiles 16 0
cable upstream 3 threshold Corr-Fec 3
cable upstream 3 threshold Uncorr-Fec 1
no cable upstream 3 shutdown
```

# Additional References

The following sections provide references related to Spectrum Management and Advanced Spectrum Management for the Cisco CMTS routers.

## Related Documents

Related Topic	Document Title
CMTS Command Reference	<a href="#">Cisco Broadband Cable Command Reference Guide.</a>

## Standards and RFCs

Standards	Title
SP-RFIV1.1-I09-020830	Data-over-Cable Service Interface Specifications Radio Frequency Interface Specification, version 1.1
SP-RFIV2.0-I03-021218	Data-over-Cable Service Interface Specifications Radio Frequency Interface Specification, version 2.0
SP-OSSIV2.0-I03-021218	Data-over-Cable Service Interface Specifications Operations Support System Interface Specification, version 2.0
SP-BPI+-I09-020830	Data-over-Cable Service Interface Specifications Baseline Privacy Plus Interface Specification, version 2.0

## MIBs

MIBs	MIBs Link
CISCO-CABLE-SPECTRUM-MIB	To locate and download MIBs for selected platforms, Cisco IOS releases, and feature sets, use Cisco MIB Locator found at the following URL: <a href="https://www.cisco.com/go/mibs">https://www.cisco.com/go/mibs</a>

## Technical Assistance

Description	Link
The Cisco Support and Documentation website provides online resources to download documentation, software, and tools. Use these resources to install and configure the software and to troubleshoot and resolve technical issues with Cisco products and technologies. Access to most tools on the Cisco Support and Documentation website requires a Cisco.com user ID and password.	<a href="https://www.cisco.com/cisco/web/support/index.html">https://www.cisco.com/cisco/web/support/index.html</a>

# Feature Information for Spectrum Management and Advanced Spectrum Management

Use Cisco Feature Navigator to find information about the platform support and software image support. Cisco Feature Navigator enables you to determine which software images support a specific software release, feature set, or platform. To access Cisco Feature Navigator, go to the <https://cfng.cisco.com/> link. An account on the Cisco.com page is not required.



**Note** The following table lists the software release in which a given feature is introduced. Unless noted otherwise, subsequent releases of that software release train also support that feature.

Feature Name	Releases	Feature Information
Spectrum Management and Advanced Spectrum Management	Cisco IOS XE Fuji 16.7.1	This feature was integrated on the Cisco cBR Series Converged Broadband Routers.





## CHAPTER 26

# Upstream Scheduler Mode

---

This document describes how to configure optional upstream (US) scheduler modes.

With this feature, you can select Unsolicited Grant Services (UGS), Real Time Polling Service (rtPS) or Non-Real Time Polling Service (nrtPS) scheduling types, as well as packet-based or Time Division Multiplex (TDM) based scheduling. Low latency queuing (LLQ) emulates a packet-mode-like operation over the TDM infrastructure of DOCSIS. As such, the feature provides the typical trade-off between packets and TDM. With LLQ, you have more flexibility in defining service parameters for UGS, rtPS or nrtPS, but with no guarantee (other than statistical distribution) regarding parameters such as delay and jitter.

- [Finding Feature Information, on page 493](#)
- [Hardware Compatibility Matrix for the Cisco cBR Series Routers, on page 493](#)
- [Restrictions for Upstream Scheduler Mode, on page 495](#)
- [Information About Upstream Scheduler Mode for the Cisco CMTS Routers, on page 495](#)
- [How to Configure Upstream Scheduler Modes, on page 495](#)
- [Additional References, on page 497](#)
- [Feature Information for Upstream Scheduler Mode, on page 497](#)

## Finding Feature Information

Your software release may not support all the features that are documented in this module. For the latest feature information and caveats, see the release notes for your platform and software release. The Feature Information Table at the end of this document provides information about the documented features and lists the releases in which each feature is supported.

Use Cisco Feature Navigator to find information about platform support and Cisco software image support. To access Cisco Feature Navigator, go to <http://tools.cisco.com/ITDIT/CFN/>. An account on <http://www.cisco.com/> is not required.

## Hardware Compatibility Matrix for the Cisco cBR Series Routers



---

**Note** The hardware components that are introduced in a given Cisco IOS-XE Release are supported in all subsequent releases unless otherwise specified.

---

Table 97: Hardware Compatibility Matrix for the Cisco cBR Series Routers

Cisco CMTS Platform	Processor Engine	Interface Cards
Cisco cBR-8 Converged Broadband Router	<p><b>Cisco IOS-XE Release 16.5.1 and Later Releases</b></p> <p>Cisco cBR-8 Supervisor:</p> <ul style="list-style-type: none"> <li>• PID—CBR-SUP-250G</li> <li>• PID—CBR-CCAP-SUP-160G</li> </ul>	<p><b>Cisco IOS-XE Release 16.5.1 and Later Releases</b></p> <p>Cisco cBR-8 CCAP Line Cards:</p> <ul style="list-style-type: none"> <li>• PID—CBR-LC-8D30-16U30</li> <li>• PID—CBR-LC-8D31-16U30</li> <li>• PID—CBR-RF-PIC</li> <li>• PID—CBR-RF-PROT-PIC</li> <li>• PID—CBR-CCAP-LC-40G</li> <li>• PID—CBR-CCAP-LC-40G-R</li> <li>• PID—CBR-CCAP-LC-G2-R</li> <li>• PID—CBR-SUP-8X10G-PIC</li> <li>• PID—CBR-2X100G-PIC</li> </ul> <p>Digital PICs:</p> <ul style="list-style-type: none"> <li>• PID—CBR-DPIC-8X10G</li> <li>• PID—CBR-DPIC-2X100G</li> </ul> <p>Cisco cBR-8 Downstream PHY Module:</p> <ul style="list-style-type: none"> <li>• PID—CBR-D31-DS-MOD</li> </ul> <p>Cisco cBR-8 Upstream PHY Modules:</p> <ul style="list-style-type: none"> <li>• PID—CBR-D31-US-MOD</li> </ul>



**Note** Do not use DPICs (8X10G and 2x100G) to forward IP traffic, as it may cause buffer exhaustion, leading to line card reload.

The only allowed traffic on a DPIC interface is DEPI, UEPI, and GCP traffic from the Cisco cBR-8 router to Remote PHY devices. Other traffic such as DHCP, SSH, and UTSC should flow via another router, since DPICs cannot be used for normal routing.

## Restrictions for Upstream Scheduler Mode

- To ensure proper operation, Interface-based Admission Control must be enabled. When the LLQ option is enabled, it is possible for the upstream path to be filled with so many calls that it becomes unusable, making voice quality unacceptable. Interface-based admission control must be used to limit the number of calls to ensure acceptable voice quality, as well as to ensure traffic other than voice traffic.
- Even if Interface-based admission control is not enabled, the default (DOCSIS) scheduling mode blocks traffic after a certain number of calls.
- UGS with Activity Detection (UGS-AD) is not supported by the LLQ scheduler mode but remains supported by the default DOCSIS scheduler mode.

## Information About Upstream Scheduler Mode for the Cisco CMTS Routers

With UGS, a service flow is created that enables a cable modem to transmit fixed-size bursts of data at a guaranteed rate and with a guaranteed level of jitter by providing periodic transmission opportunities to the cable modem for fixed-sized frames. This kind of service flow is particularly suitable for VoIP applications.

With rtPS, a service flow is created that provides a periodic opportunity for a cable modem to request permission to transmit data by polling a single cable modem for a bandwidth request, rather than all the cable modems. This satisfies applications that have a requirement for real-time data transmission, and enables the cable modem to transmit data bursts of varying length. This kind of service flow is particularly suitable for MPEG VoIP.

The rtPS requests, by default, are internally treated as priority 7—the highest priority for all Best Effort traffic. This high priority reduces the latency of rtPS traffic under congestion.

With nrtPS, a service flow is created that provides a periodic opportunity for a cable modem to request permission to transmit data by polling a single cable modem for a bandwidth request, rather than all the cable modems. The data bursts may be of varying length. This kind of service flow is particularly suitable for non-interactive services such as file transfers.

## How to Configure Upstream Scheduler Modes

### Procedure

	Command or Action	Purpose
Step 1	<b>enable</b> <b>Example:</b> Router> <b>enable</b>	Enables privileged EXEC mode. <ul style="list-style-type: none"> <li>• Enter your password if prompted.</li> </ul>
Step 2	<b>configure terminal</b> <b>Example:</b>	Enters global configuration mode.

	Command or Action	Purpose
	Router# <code>configure terminal</code>	
<b>Step 3</b>	Use one the following commands: <ul style="list-style-type: none"> <li>• <code>interface cable slot/subslot/port</code></li> <li>• <code>interface cable slot/port</code></li> </ul> <b>Example:</b> Router(config)# <code>interface cable 7/0/1</code>	Enters interface configuration mode for the specified cable interface.
<b>Step 4</b>	<code>cable upstream n scheduling type ugs mode [llq   docsis]</code> <b>Example:</b> Router(config-if)# <code>cable upstream 4 scheduling type ugs mode llq</code>	Enables LLQ-type (packet-based) scheduling for UGS services.  <b>Note</b> Any combination of <code>ugs</code> , <code>rtps</code> , <code>nrtps</code> , <code>llq</code> , and <code>docsis</code> is allowed. The only default value is <code>docsis</code> .
<b>Step 5</b>	<code>cable upstream n scheduling type rtps mode [llq   docsis]</code> <b>Example:</b> Router(config-if)# <code>cable upstream 4 scheduling type rtps mode docsis</code>	Enables standard DOCSIS (TDM-based) scheduling for rtPS services.  <b>Note</b> Any combination of <code>ugs</code> , <code>rtps</code> , <code>nrtps</code> , <code>llq</code> , and <code>docsis</code> is allowed. The only default value is <code>docsis</code> .
<b>Step 6</b>	<code>end</code> <b>Example:</b> Router(config-if)# <code>end</code>	Exits interface configuration mode and returns to privileged EXEC mode.

### What to do next

To confirm whether the scheduler is operating in DOCSIS mode, use the `show interface cable mac-scheduler` command.

```
Router# show interface cable 7/0/1 mac-scheduler 0
DOCSIS 1.1 MAC scheduler for Cable7/0/1/U0 : rate 30720000
wfq:None
us_balance:OFF
fairness:OFF
Queue[Rng Polls] flows 0
Queue[CIR Grants] flows 0
Queue[BE(07) Grants] flows 0
Queue[BE(06) Grants] flows 0
Queue[BE(05) Grants] flows 0
Queue[BE(04) Grants] flows 0
Queue[BE(03) Grants] flows 0
Queue[BE(02) Grants] flows 0
Queue[BE(01) Grants] flows 0
Queue[BE(00) Grants] flows 0
Req Slots 2601578997, Req/Data Slots 4484512
Init Mtn Slots 38265829, Stn Mtn Slots 78753
Short Grant Slots 0, Long Grant Slots 0
Adv Phy Short Grant Slots 412, Adv Phy Long Grant Slots 5519087
Adv Phy UGS Grant Slots 0
Avg upstream channel utilization : 1%
Avg percent contention slots : 98%
Avg percent initial ranging slots : 1%
```

```

Avg percent minislots lost on late MAPs : 0%

MAP TSS: lch_state 9, init_retries 0
         late_initial_maps 0, late_ucd_maps 0
         mac-phy tss errors 0, missed ccc 0

```

## Additional References

The following sections provide references related to the Cisco CMTS routers.

### Related Documents

Related Topic	Document Title
Cisco CMTS command reference	<i>Cisco CMTS Cable Command Reference</i> <a href="http://www.cisco.com/c/en/us/td/docs/cable/cmts/cmd_ref/b_cmts_cable_cmd_ref.html">http://www.cisco.com/c/en/us/td/docs/cable/cmts/cmd_ref/b_cmts_cable_cmd_ref.html</a>

### Standards

Standard	Title
DOCSIS	Data-Over-Cable Service Interface Specifications, DOCSIS 2.0, Radio Frequency Interface Specification, CM-SP-RFIV2.0-I08-050408

### Technical Assistance

Description	Link
The Cisco Support and Documentation website provides online resources to download documentation, software, and tools. Use these resources to install and configure the software and to troubleshoot and resolve technical issues with Cisco products and technologies. Access to most tools on the Cisco Support and Documentation website requires a Cisco.com user ID and password.	<a href="http://www.cisco.com/cisco/web/support/index.html">http://www.cisco.com/cisco/web/support/index.html</a>

## Feature Information for Upstream Scheduler Mode

Use Cisco Feature Navigator to find information about the platform support and software image support. Cisco Feature Navigator enables you to determine which software images support a specific software release, feature set, or platform. To access Cisco Feature Navigator, go to the <https://cfng.cisco.com/> link. An account on the Cisco.com page is not required.



**Note** The following table lists the software release in which a given feature is introduced. Unless noted otherwise, subsequent releases of that software release train also support that feature.

**Table 98: Feature Information for Upstream Scheduler Mode**

Feature Name	Releases	Feature Information
Upstream Scheduler Mode	Cisco IOS XE Fuji 16.7.1	This feature was integrated on the Cisco cBR Series Converged Broadband Routers.



## CHAPTER 27

# Generic Routing Encapsulation

This document describes the Generic Routing Encapsulation (GRE) feature. This feature is a tunneling protocol that enables the encapsulation of a wide variety of protocol packet types inside IP tunnels, creating a virtual point-to-point link to Cisco routers at remote points over an IP internetwork.

- [Finding Feature Information, on page 499](#)
- [Hardware Compatibility Matrix for the Cisco cBR Series Routers, on page 500](#)
- [Restrictions for Implementing Tunnels, on page 501](#)
- [Restrictions for GRE IPv6 Tunnels, on page 502](#)
- [Information About Implementing Tunnels, on page 502](#)
- [Information About IPv6 over IPv4 GRE Tunnels, on page 504](#)
- [Information About GRE IPv6 Tunnels, on page 506](#)
- [How to Implement Tunnels, on page 506](#)
- [Configuration Examples for Implementing Tunnels, on page 513](#)
- [How to Configure IPv6 over IPv4 GRE Tunnels, on page 516](#)
- [Configuration Examples for IPv6 over IPv4 GRE Tunnels, on page 517](#)
- [How to Configure GRE IPv6 Tunnels, on page 518](#)
- [Configuration Examples for GRE IPv6 Tunnels, on page 520](#)
- [Additional References, on page 520](#)
- [Feature Information for Generic Routing Encapsulation , on page 522](#)

## Finding Feature Information

Your software release may not support all the features that are documented in this module. For the latest feature information and caveats, see the release notes for your platform and software release. The Feature Information Table at the end of this document provides information about the documented features and lists the releases in which each feature is supported.

Use Cisco Feature Navigator to find information about platform support and Cisco software image support. To access Cisco Feature Navigator, go to <http://tools.cisco.com/ITDIT/CFN/>. An account on <http://www.cisco.com/> is not required.

# Hardware Compatibility Matrix for the Cisco cBR Series Routers



**Note** The hardware components that are introduced in a given Cisco IOS-XE Release are supported in all subsequent releases unless otherwise specified.

**Table 99: Hardware Compatibility Matrix for the Cisco cBR Series Routers**

Cisco CMTS Platform	Processor Engine	Interface Cards
Cisco cBR-8 Converged Broadband Router	<p><b>Cisco IOS-XE Release 16.5.1 and Later Releases</b></p> <p>Cisco cBR-8 Supervisor:</p> <ul style="list-style-type: none"> <li>• PID—CBR-SUP-250G</li> <li>• PID—CBR-CCAP-SUP-160G</li> </ul>	<p><b>Cisco IOS-XE Release 16.5.1 and Later Releases</b></p> <p>Cisco cBR-8 CCAP Line Cards:</p> <ul style="list-style-type: none"> <li>• PID—CBR-LC-8D30-16U30</li> <li>• PID—CBR-LC-8D31-16U30</li> <li>• PID—CBR-RF-PIC</li> <li>• PID—CBR-RF-PROT-PIC</li> <li>• PID—CBR-CCAP-LC-40G</li> <li>• PID—CBR-CCAP-LC-40G-R</li> <li>• PID—CBR-CCAP-LC-G2-R</li> <li>• PID—CBR-SUP-8X10G-PIC</li> <li>• PID—CBR-2X100G-PIC</li> </ul> <p>Digital PICs:</p> <ul style="list-style-type: none"> <li>• PID—CBR-DPIC-8X10G</li> <li>• PID—CBR-DPIC-2X100G</li> </ul> <p>Cisco cBR-8 Downstream PHY Module:</p> <ul style="list-style-type: none"> <li>• PID—CBR-D31-DS-MOD</li> </ul> <p>Cisco cBR-8 Upstream PHY Modules:</p> <ul style="list-style-type: none"> <li>• PID—CBR-D31-US-MOD</li> </ul>





**Note** Do not use DPICs (8X10G and 2x100G) to forward IP traffic, as it may cause buffer exhaustion, leading to line card reload.

The only allowed traffic on a DPIC interface is DEPI, UEPI, and GCP traffic from the Cisco cBR-8 router to Remote PHY devices. Other traffic such as DHCP, SSH, and UTSC should flow via another router, since DPICs cannot be used for normal routing.

## Restrictions for Implementing Tunnels

- It is important to allow the tunnel protocol to pass through a firewall and access control list (ACL) check.
- Multiple point-to-point tunnels can saturate the physical link with routing information if the bandwidth is not configured correctly on a tunnel interface.
- A tunnel looks like a single hop link, and routing protocols may prefer a tunnel over a multihop physical path. The tunnel, despite looking like a single hop link, may traverse a slower path than a multihop link. A tunnel is as robust and fast, or as unreliable and slow, as the links that it actually traverses. Routing protocols that make their decisions based only on hop counts will often prefer a tunnel over a set of physical links. A tunnel might appear to be a one-hop, point-to-point link and have the lowest-cost path, but the tunnel may actually cost more in terms of latency when compared to an alternative physical topology. For example, in the topology shown in the figure below, packets from Host 1 will appear to travel across networks w, t, and z to get to Host 2 instead of taking the path w, x, y, and z because the tunnel hop count appears shorter. In fact, the packets going through the tunnel will still be traveling across Router A, B, and C, but they must also travel to Router D before coming back to Router C.

**Figure 20: Tunnel Precautions: Hop Counts**

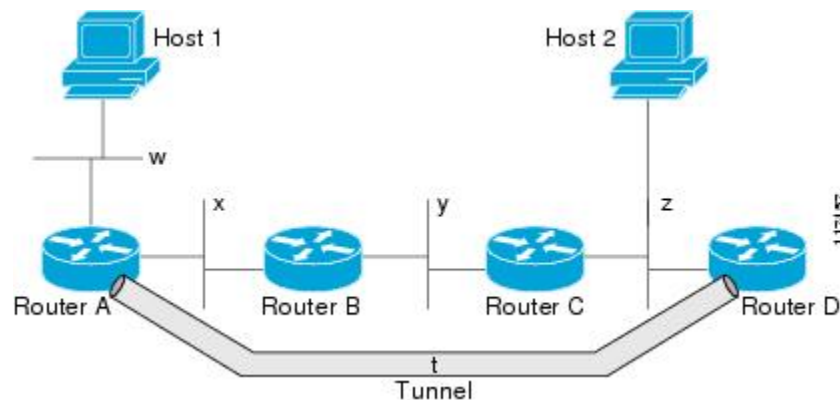

- A tunnel may have a recursive routing problem if routing is not configured accurately. The best path to a tunnel destination is via the tunnel itself; therefore recursive routing causes the tunnel interface to flap. To avoid recursive routing problems, keep the control-plane routing separate from the tunnel routing by using the following methods:
  - Use a different autonomous system number or tag.
  - Use a different routing protocol.
  - Ensure that static routes are used to override the first hop (watch for routing loops).

The following error is displayed when there is recursive routing to a tunnel destination:

```
%TUN-RECURDOWN Interface Tunnel 0  
temporarily disabled due to recursive routing
```

## Restrictions for GRE IPv6 Tunnels

- GRE tunnel keepalive packets are not supported.
- Multipoint GRE (mGRE) IPv6 tunneling is not supported.

## Information About Implementing Tunnels

### Tunneling Versus Encapsulation

To understand how tunnels work, you must be able to distinguish between concepts of encapsulation and tunneling. Encapsulation is the process of adding headers to data at each layer of a particular protocol stack. The Open Systems Interconnection (OSI) reference model describes the functions of a network. To send a data packet from one host (for example, a PC) to another on a network, encapsulation is used to add a header in front of the data packet at each layer of the protocol stack in descending order. The header must contain a data field that indicates the type of data encapsulated at the layer immediately above the current layer. As the packet ascends the protocol stack on the receiving side of the network, each encapsulation header is removed in reverse order.

Tunneling encapsulates data packets from one protocol within a different protocol and transports the packets on a foreign network. Unlike encapsulation, tunneling allows a lower-layer protocol and a same-layer protocol to be carried through the tunnel. A tunnel interface is a virtual (or logical) interface. Tunneling consists of three main components:

- Passenger protocol—The protocol that you are encapsulating. For example, IPv4 and IPv6 protocols.
- Carrier protocol—The protocol that encapsulates. For example, generic routing encapsulation (GRE) and Multiprotocol Label Switching (MPLS).
- Transport protocol--The protocol that carries the encapsulated protocol. The main transport protocol is IP.

### Tunnel ToS

Tunnel type of service (ToS) allows you to tunnel network traffic and group all packets in the same ToS byte value. The ToS byte values and Time-to-Live (TTL) hop-count value can be set in the encapsulating IP header of tunnel packets for an IP tunnel interface on a router. Tunnel ToS feature is supported for Cisco Express Forwarding (formerly known as CEF), fast switching, and process switching.

The ToS and TTL byte values are defined in RFC 791. RFC 2474, and RFC 2780 obsolete the use of the ToS byte as defined in RFC 791. RFC 791 specifies that bits 6 and 7 of the ToS byte (the first two least significant bits) are reserved for future use and should be set to 0.

## Path MTU Discovery

Path MTU Discovery (PMTUD) can be enabled on a GRE or IP-in-IP tunnel interface. When PMTUD (RFC 1191) is enabled on a tunnel interface, the router performs PMTUD processing for the GRE (or IP-in-IP) tunnel IP packets. The router always performs PMTUD processing on the original data IP packets that enter the tunnel. When PMTUD is enabled, packet fragmentation is not permitted for packets that traverse the tunnel because the Don't Fragment (DF) bit is set on all the packets. If a packet that enters the tunnel encounters a link with a smaller MTU, the packet is dropped and an Internet Control Message Protocol (ICMP) message is sent back to the sender of the packet. This message indicates that fragmentation was required (but not permitted) and provides the MTU of the link that caused the packet to be dropped.



---

**Note** PMTUD on a tunnel interface requires that the tunnel endpoint be able to receive ICMP messages generated by routers in the path of the tunnel. Ensure that ICMP messages can be received before using PMTUD over firewall connections.

---

Use the **tunnel path-mtu-discovery** command to enable PMTUD for the tunnel packets and use the **show interfaces tunnel** command to verify the tunnel PMTUD parameters. PMTUD works only on GRE and IP-in-IP tunnel interfaces.

## QoS Options for Tunnels

A tunnel interface supports various quality of service (QoS) features as a physical interface. QoS provides a way to ensure that mission-critical traffic has an acceptable level of performance. QoS options for tunnels include support for applying generic traffic shaping (GTS) directly on the tunnel interface and support for class-based shaping using the modular QoS CLI (MQC). Tunnel interfaces also support class-based policing, but they do not support committed access rate (CAR).

GRE tunnels allow the router to copy the IP precedence bit values of the ToS byte to the tunnel or the GRE IP header that encapsulates the inner packet. Intermediate routers between the tunnel endpoints can use the IP precedence values to classify packets for QoS features such as policy routing, weighted fair queuing (WFQ), and weighted random early detection (WRED).

When packets are encapsulated by tunnel or encryption headers, QoS features are unable to examine the original packet headers and correctly classify the packets. Packets that travel across the same tunnel have the same tunnel headers, so the packets are treated identically if the physical interface is congested. Tunnel packets can, however, be classified before tunneling and encryption can occur when a user applies the QoS preclassify feature on the tunnel interface or on the crypto map.



---

**Note** Class-based WFQ (CBWFQ) inside class-based shaping is not supported on a multipoint interface.

---

For examples of how to implement some QoS features on a tunnel interface, see the section “[Configuring QoS Options on Tunnel Interfaces Examples, on page 514](#)”.

# Information About IPv6 over IPv4 GRE Tunnels

## Overlay Tunnels for IPv6

Overlay tunneling encapsulates IPv6 packets in IPv4 packets for delivery across an IPv4 infrastructure (a core network or the figure below). By using overlay tunnels, you can communicate with isolated IPv6 networks without upgrading the IPv4 infrastructure between them. Overlay tunnels can be configured between border devices or between a border device and a host; however, both tunnel endpoints must support both the IPv4 and IPv6 protocol stacks. IPv6 supports the following types of overlay tunneling mechanisms:

- Manual
- Generic routing encapsulation (GRE)
- IPv4-compatible
- 6to4
- Intrasite Automatic Tunnel Addressing Protocol (ISATAP)

Figure 21: Overlay Tunnels

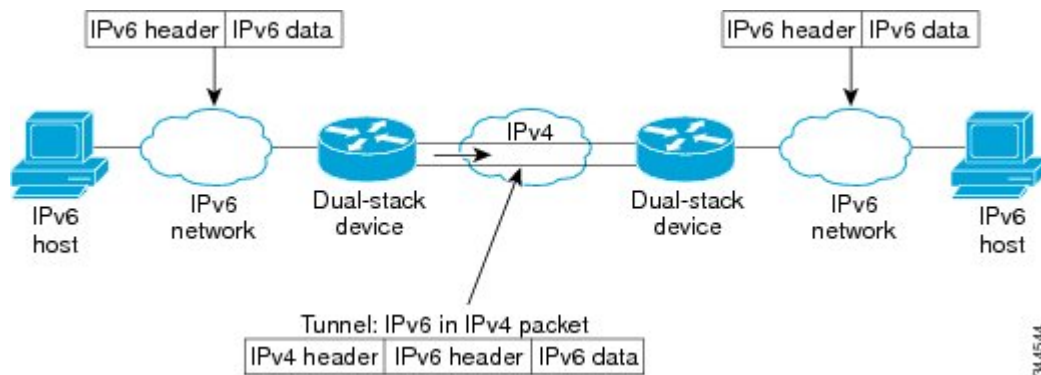

**Note** Overlay tunnels reduce the maximum transmission unit (MTU) of an interface by 20 octets (assuming that the basic IPv4 packet header does not contain optional fields). A network that uses overlay tunnels is difficult to troubleshoot. Therefore, overlay tunnels that connect isolated IPv6 networks should not be considered a final IPv6 network architecture. The use of overlay tunnels should be considered as a transition technique toward a network that supports both the IPv4 and IPv6 protocol stacks or just the IPv6 protocol stack.

Use the table below to help you determine which type of tunnel that you want to configure to carry IPv6 packets over an IPv4 network.

Table 100: Suggested Usage of Tunnel Types to Carry IPv6 Packets over an IPv4 Network

Tunneling Type	Suggested Usage	Usage Notes
Manual	Simple point-to-point tunnels that can be used within a site or between sites.	Can carry IPv6 packets only.

Tunneling Type	Suggested Usage	Usage Notes
GRE- and IPv4-compatible	Simple point-to-point tunnels that can be used within a site or between sites.	Can carry IPv6, Connectionless Network Service (CLNS), and many other types of packets.
IPv4- compatible	Point-to-multipoint tunnels.	Uses the ::/96 prefix. We do not recommend using this tunnel type.
6to4	Point-to-multipoint tunnels that can be used to connect isolated IPv6 sites.	Sites use addresses from the 2002::/16 prefix.
6RD	IPv6 service is provided to customers over an IPv4 network by using encapsulation of IPv6 in IPv4.	Prefixes can be from the SP's own address block.
ISATAP	Point-to-multipoint tunnels that can be used to connect systems within a site.	Sites can use any IPv6 unicast addresses.

Individual tunnel types are discussed in detail in this document. We recommend that you review and understand the information about the specific tunnel type that you want to implement. When you are familiar with the type of tunnel you need, see the table below for a summary of the tunnel configuration parameters that you may find useful.

**Table 101: Tunnel Configuration Parameters by Tunneling Type**

Tunneling Type	Tunnel Configuration Parameter			
Tunnel Mode	Tunnel Source	Tunnel Destination	Interface Prefix or Address	
Manual	ipv6ip	An IPv4 address, or a reference to an interface on which IPv4 is configured.	An IPv4 address.	An IPv6 address.
GRE/IPv4	gre ip		An IPv4 address.	An IPv6 address.
IPv4- compatible	ipv6ip auto-tunnel		Not required. These are all point-to-multipoint tunneling types. The IPv4 destination address is calculated, on a per-packet basis, from the IPv6 destination.	Not required. The interface address is generated as :: <i>tunnel-source</i> /96.
6to4	ipv6ip 6to4		An IPv6 address. The prefix must embed the tunnel source IPv4 address.	
6RD	ipv6ip 6rd		An IPv6 address.	
ISATAP	ipv6ip isatap		An IPv6 prefix in modified eui-64 format. The IPv6 address is generated from the prefix and the tunnel source IPv4 address.	

## GRE IPv4 Tunnel Support for IPv6 Traffic

IPv6 traffic can be carried over IPv4 GRE tunnels using the standard GRE tunneling technique that is designed to provide the services to implement any standard point-to-point encapsulation scheme. As in IPv6 manually

configured tunnels, GRE tunnels are links between two points, with a separate tunnel for each link. The tunnels are not tied to a specific passenger or transport protocol but, in this case, carry IPv6 as the passenger protocol with the GRE as the carrier protocol and IPv4 or IPv6 as the transport protocol.

The primary use of GRE tunnels is for stable connections that require regular secure communication between two edge devices or between an edge device and an end system. The edge devices and the end systems must be dual-stack implementations.

## Information About GRE IPv6 Tunnels

### Overview of GRE IPv6 Tunnels

The GRE IPv6 Tunnels feature enables the delivery of packets from other protocols through an IPv6 network and allows the routing of IPv6 packets between private networks across public networks with globally routed IPv6 addresses.

For point-to-point GRE tunnels, each tunnel interface requires a tunnel source IPv6 address and a tunnel destination IPv6 address when being configured. All packets are encapsulated with an outer IPv6 header and a GRE header.

## How to Implement Tunnels

### Determining the Tunnel Type

Before configuring a tunnel, you must determine the type of tunnel you want to create.

#### SUMMARY STEPS

1. Determine the passenger protocol. A passenger protocol is the protocol that you are encapsulating.
2. Determine the **tunnel mode** command keyword, if appropriate.

#### DETAILED STEPS

**Step 1** Determine the passenger protocol. A passenger protocol is the protocol that you are encapsulating.

**Step 2** Determine the **tunnel mode** command keyword, if appropriate.

The table below shows how to determine the appropriate keyword to be used with the **tunnel mode** command.

*Table 102: Determining the tunnel mode Command Keyword*

Keyword	Purpose
<b>dvmrp</b>	Use the <b>dvmrp</b> keyword to specify that the Distance Vector Multicast Routing Protocol encapsulation will be used.
<b>gre ip</b>	Use the <b>gre</b> and <b>ip</b> keywords to specify that GRE encapsulation over IP will be used.

Keyword	Purpose
<b>gre ipv6</b>	Use the <b>gre</b> and <b>ipv6</b> keywords to specify that GRE encapsulation over IPv6 will be used.
<b>ipip [decapsulate-any]</b>	Use the <b>ipip</b> keyword to specify that IP-in-IP encapsulation will be used. The optional <b>decapsulate-any</b> keyword terminates any number of IP-in-IP tunnels at one tunnel interface. Note that this tunnel will not carry any outbound traffic; however, any number of remote tunnel endpoints can use a tunnel configured as their destination.
<b>ipv6</b>	Use the <b>ipv6</b> keyword to specify that generic packet tunneling in IPv6 will be used.
<b>ipv6ip</b>	Use the <b>ipv6ip</b> keyword to specify that IPv6 will be used as the passenger protocol and IPv4 as both the carrier (encapsulation) and transport protocol. When additional keywords are not used, manual IPv6 tunnels are configured. Additional keywords can be used to specify IPv4-compatible, 6to4, or ISATAP tunnels.
<b>mpls</b>	Use the <b>mpls</b> keyword to specify that MPLS will be used for configuring traffic engineering (TE) tunnels.

## Configuring an IPv4 GRE Tunnel

Perform this task to configure a GRE tunnel. A tunnel interface is used to pass protocol traffic across a network that does not normally support the protocol. To build a tunnel, you must define a tunnel interface on each of the two routers, and the tunnel interfaces must reference each other. At each router, the tunnel interface must be configured with a Layer 3 address. The tunnel endpoints, tunnel source, and tunnel destination must be defined, and the type of tunnel must be selected. Optional steps can be performed to customize the tunnel.

Remember to configure the router at each end of the tunnel. If only one side of a tunnel is configured, the tunnel interface may still come up and stay up (unless keepalive is configured), but packets going into the tunnel will be dropped.

### GRE Tunnel Keepalive

Keepalive packets can be configured to be sent over IP-encapsulated GRE tunnels. You can specify the rate at which keepalives are sent and the number of times that a device will continue to send keepalive packets without a response before the interface becomes inactive. GRE keepalive packets may be sent from both sides of a tunnel or from just one side.

#### Before you begin

Ensure that the physical interface to be used as the tunnel source in this task is up and configured with the appropriate IP address. For hardware technical descriptions and information about installing interfaces, see the hardware installation and configuration publication for your product.

#### Procedure

	Command or Action	Purpose
Step 1	enable  Example:	Enables privileged EXEC mode.  • Enter your password if prompted.

	Command or Action	Purpose
	<code>Router&gt; enable</code>	
<b>Step 2</b>	<b>configure terminal</b> <b>Example:</b> <code>Router# configure terminal</code>	Enters global configuration mode.
<b>Step 3</b>	<b>interface <i>type number</i></b> <b>Example:</b> <code>Router(config)# interface tunnel 0</code>	Specifies the interface type and number, and enters interface configuration mode. <ul style="list-style-type: none"> <li>To configure a tunnel, use <b>tunnel</b> for the <i>type</i> argument.</li> </ul>
<b>Step 4</b>	<b>bandwidth <i>kb/s</i></b> <b>Example:</b> <code>Router(config-if)# bandwidth 1000</code>	Sets the current bandwidth value for an interface and communicates it to higher-level protocols. <ul style="list-style-type: none"> <li>Specifies the tunnel bandwidth to be used to transmit packets.</li> <li>Use the <i>kb/s</i> argument to set the bandwidth, in kilobits per second (kb/s).</li> </ul> <p><b>Note</b> This is only a routing parameter; it does not affect the physical interface. The default bandwidth setting on a tunnel interface is 9.6 kb/s. You should set the bandwidth on a tunnel to an appropriate value.</p>
<b>Step 5</b>	<b>keepalive [<i>period</i> [<i>retries</i>]]</b> <b>Example:</b> <code>Router(config-if)# keepalive 3 7</code>	(Optional) Specifies the number of times the device will continue to send keepalive packets without response before bringing the tunnel interface protocol down. <ul style="list-style-type: none"> <li>GRE keepalive packets may be configured either on only one side of the tunnel or on both.</li> <li>If GRE keepalive is configured on both sides of the tunnel, the <i>period</i> and <i>retries</i> arguments can be different at each side of the link.</li> </ul> <p><b>Note</b> This command is supported only on GRE point-to-point tunnels.</p> <p><b>Note</b> The GRE tunnel keepalive feature should not be configured on a VRF tunnel. This combination of features is not supported.</p>
<b>Step 6</b>	<b>tunnel source {<i>ip-address</i>   <i>interface-type interface-number</i>}</b> <b>Example:</b> <code>Router(config-if)# tunnel source TenGigabitEthernet 4/1/0</code>	Configures the tunnel source. <p><b>Note</b> The tunnel source IP address and destination IP addresses must be defined on two separate devices.</p>



	Command or Action	Purpose
Step 7	<p><b>tunnel destination</b> {hostname   ip-address}</p> <p><b>Example:</b></p> <pre>Router(config-if)# tunnel destination 10.0.2.1</pre>	<p>Configures the tunnel destination.</p> <p><b>Note</b> The tunnel source and destination IP addresses must be defined on two separate devices.</p>
Step 8	<p><b>tunnel key</b> key-number</p> <p><b>Example:</b></p> <pre>Router(config-if)# tunnel key 1000</pre>	<p>(Optional) Enables an ID key for a tunnel interface.</p> <p><b>Note</b> This command is supported only on GRE tunnel interfaces. We do not recommend relying on this key for security purposes.</p>
Step 9	<p><b>tunnel mode gre</b> { ip   multipoint }</p> <p><b>Example:</b></p> <pre>Device(config-if)# tunnel mode gre ip</pre>	<p>Specifies the encapsulation protocol to be used in the tunnel.</p>
Step 10	<p><b>ip mtu</b> bytes</p> <p><b>Example:</b></p> <pre>Device(config-if)# ip mtu 1400</pre>	<p>(Optional) Sets the MTU size of IP packets sent on an interface.</p> <ul style="list-style-type: none"> <li>• If an IP packet exceeds the MTU set for the interface, the Cisco software will fragment it unless the DF bit is set.</li> <li>• All devices on a physical medium must have the same protocol MTU in order to operate.</li> <li>• For IPv6 packets, use the <b>ipv6 mtu</b> command.</li> </ul> <p><b>Note</b> If the <b>tunnel path-mtu-discovery</b> command is enabled do not configure this command.</p>
Step 11	<p><b>ip tcp mss</b> mss-value</p> <p><b>Example:</b></p> <pre>Device(config-if)# ip tcp mss 250</pre>	<p>(Optional) Specifies the maximum segment size (MSS) for TCP connections that originate or terminate on a router.</p>
Step 12	<p><b>tunnel path-mtu-discovery</b> [age-timer {aging-mins   infinite}]</p> <p><b>Example:</b></p> <pre>Device(config-if)# tunnel path-mtu-discovery</pre>	<p>(Optional) Enables PMTUD on a GRE or IP-in-IP tunnel interface.</p> <ul style="list-style-type: none"> <li>• When PMTUD is enabled on a tunnel interface, PMTUD will operate for GRE IP tunnel packets to minimize fragmentation in the path between the tunnel endpoints.</li> </ul>
Step 13	<p><b>end</b></p> <p><b>Example:</b></p> <pre>Device(config-if)# end</pre>	<p>Exits interface configuration mode and returns to privileged EXEC mode.</p>

## What to Do Next

Proceed to the “Verifying Tunnel Configuration and Operation” section.

# Configuring 6to4 Tunnels

## Before you begin

With 6to4 tunnels, the tunnel destination is determined by the border-router IPv4 address, which is concatenated to the prefix 2002::<16 in the format 2002:*border-router-IPv4-address* ::/48. The border router at each end of a 6to4 tunnel must support both the IPv4 and IPv6 protocol stacks.



**Note** The configuration of only one IPv4-compatible tunnel and one 6to4 IPv6 tunnel is supported on a router. If you choose to configure both of these tunnel types on the same router, Cisco recommends that they not share the same tunnel source.

A 6to4 tunnel and an IPv4-compatible tunnel cannot share the same interface because both of them are NBMA “point-to-multipoint” access links, and only the tunnel source can be used to reorder the packets from a multiplexed packet stream into a single packet stream for an incoming interface. When a packet with an IPv4 protocol type of 41 arrives on an interface, the packet is mapped to an IPv6 tunnel interface on the basis of the IPv4 address. However, if both the 6to4 tunnel and the IPv4-compatible tunnel share the same source interface, the router cannot determine the IPv6 tunnel interface to which it should assign the incoming packet.

Manually configured IPv6 tunnels can share the same source interface because a manual tunnel is a “point-to-point” link, and both IPv4 source and the IPv4 destination of the tunnel are defined.

## Procedure

	Command or Action	Purpose
<b>Step 1</b>	<b>enable</b> <b>Example:</b> Router> enable	Enables privileged EXEC mode. <ul style="list-style-type: none"> <li>• Enter your password if prompted.</li> </ul>
<b>Step 2</b>	<b>configure terminal</b> <b>Example:</b> Router# configure terminal	Enters global configuration mode.
<b>Step 3</b>	<b>interface tunnel <i>tunnel-number</i></b> <b>Example:</b> Router(config)# interface tunnel 0	Specifies a tunnel interface and number and enters interface configuration mode.
<b>Step 4</b>	<b>ipv6 address <i>ipv6-prefix/prefix-length</i> [eui-64]</b> <b>Example:</b> Router(config-if)# ipv6 address 2002:c0a8:6301:1::1/64	Specifies the IPv6 address assigned to the interface and enables IPv6 processing on the interface. <ul style="list-style-type: none"> <li>• The 32 bits following the initial 2002::&lt;16 prefix correspond to an IPv4 address assigned to the tunnel source.</li> </ul> <p><b>Note</b> See the "Configuring Basic Connectivity for IPv6" module for more information on configuring IPv6 addresses.</p>

	Command or Action	Purpose
Step 5	<p><b>tunnel source</b> <i>{ip-address   interface-type interface-number}</i></p> <p><b>Example:</b></p> <pre>Router(config-if)# tunnel source TenGigabitEthernet 4/1/0</pre>	<p>Specifies the source IPv4 address or the source interface type and number for the tunnel interface.</p> <p><b>Note</b> The interface type and number specified in the <b>tunnel source</b> command must be configured with an IPv4 address.</p>
Step 6	<p><b>tunnel mode ipv6ip 6to4</b></p> <p><b>Example:</b></p> <pre>Router(config-if)# tunnel mode ipv6ip 6to4</pre>	<p>Specifies an IPv6 overlay tunnel using a 6to4 address.</p>
Step 7	<p><b>exit</b></p> <p><b>Example:</b></p> <pre>Router(config-if)# exit</pre>	<p>Exits interface configuration mode and returns to global configuration mode.</p>
Step 8	<p><b>ipv6 route</b> <i>ipv6-prefix / prefix-length tunnel tunnel-number</i></p> <p><b>Example:</b></p> <pre>Router(config)# ipv6 route 2002::/16 tunnel 0</pre>	<p>Configures a static route to the specified tunnel interface.</p> <p><b>Note</b> When configuring a 6to4 overlay tunnel, you must configure a static route for the IPv6 6to4 prefix 2002::/16 to the 6to4 tunnel interface.</p> <ul style="list-style-type: none"> <li>The tunnel number specified in the <b>ipv6 route</b> command must be the same tunnel number specified in the <b>interface tunnel</b> command.</li> </ul>
Step 9	<p><b>end</b></p> <p><b>Example:</b></p> <pre>Router(config)# end</pre>	<p>Exits global configuration mode and returns to privileged EXEC mode.</p>

## What to Do Next

Proceed to the “Verifying Tunnel Configuration and Operation” section.

## Verifying Tunnel Configuration and Operation

The **show** and **ping** commands in the steps below can be used in any sequence. The following commands can be used for GRE tunnels, IPv6 manually configured tunnels, and IPv6 over IPv4 GRE tunnels.

- 
- Step 1**     **enable**
- Enables privileged EXEC mode. Enter your password if prompted.
- Example:**
- ```
Device> enable
```
- Step 2**     **show interfaces tunnel** *number* [**accounting**]

Two routers are configured to be endpoints of a tunnel. Device A has TenGigabit Ethernet interface 4/1/0 configured as the source for tunnel interface 0 with an IPv4 address of 10.0.0.1 and an IPv6 prefix of 2001:0DB8:1111:2222::1/64. Device B has TenGigabit Ethernet interface 4/1/0 configured as the source for tunnel interface 1 with an IPv4 address of 10.0.0.2 and an IPv6 prefix of 2001:0DB8:1111:2222::2/64.

To verify that the tunnel source and destination addresses are configured, use the **show interfaces tunnel** command on Device A.

**Example:**

```
Device A# show interfaces tunnel 0

Tunnel0 is up, line protocol is up
  Hardware is Tunnel
  MTU 1514 bytes, BW 9 Kbit, DLY 500000 usec,
    reliability 255/255, txload 1/255, rxload 1/255
  Encapsulation TUNNEL, loopback not set
  Keepalive not set
  Tunnel source 10.0.0.1 (TenGigabitEthernet4/1/0), destination 10.0.0.2, fastswitch TTL 255
  Tunnel protocol/transport GRE/IP, key disabled, sequencing disabled
  Tunnel TTL 255
  Checksumming of packets disabled, fast tunneling enabled
  Last input 00:00:14, output 00:00:04, output hang never
  Last clearing of "show interface" counters never
  Input queue: 0/75/0/0 (size/max/drops/flushes); Total output drops: 0
  Queueing strategy: fifo
  Output queue :0/0 (size/max)
  5 minute input rate 0 bits/sec, 0 packets/sec
  5 minute output rate 0 bits/sec, 0 packets/sec
    4 packets input, 352 bytes, 0 no buffer
    Received 0 broadcasts, 0 runts, 0 giants, 0 throttles
    0 input errors, 0 CRC, 0 frame, 0 overrun, 0 ignored, 0 abort
    8 packets output, 704 bytes, 0 underruns
    0 output errors, 0 collisions, 0 interface resets
    0 output buffer failures, 0 output buffers swapped out
```

**Step 3** ping [*protocol*] *destination*

To check that the local endpoint is configured and working, use the **ping** command on Device A.

**Example:**

```
DeviceA# ping 2001:0DB8:1111:2222::2

Type escape sequence to abort.
Sending 5, 100-byte ICMP Echos to 2001:0DB8:1111:2222::2, timeout is 2 seconds:
!!!!
Success rate is 100 percent (5/5), round-trip min/avg/max = 20/20/20 ms
```

**Step 4** show ip route [*address* [*mask*]]

To check that a route exists to the remote endpoint address, use the **show ip route** command.

**Example:**

```
DeviceA# show ip route 10.0.0.2

Routing entry for 10.0.0.0/24
  Known via "connected", distance 0, metric 0 (connected, via interface)
  Routing Descriptor Blocks:
  * directly connected, via TenGigabitEthernet4/1/0
    Route metric is 0, traffic share count is 1
```

**Step 5** ping *[protocol] destination*

To check that the remote endpoint address is reachable, use the **ping** command on Device A.

**Note** The remote endpoint address may not be reachable using the **ping** command because of filtering, but the tunnel traffic may still reach its destination.

**Example:**

```
DeviceA# ping 10.0.0.2
```

```
Type escape sequence to abort.
```

```
Sending 5, 100-byte ICMP Echos to 10.0.0.2, timeout is 2 seconds:
```

```
!!!!!
```

```
Success rate is 100 percent (5/5), round-trip min/avg/max = 20/21/28 ms
```

To check that the remote IPv6 tunnel endpoint is reachable, use the **ping** command again on Device A. The note regarding filtering earlier in step also applies to this example.

**Example:**

```
DeviceA# ping 2001:0DB8:1111:2222::2
```

```
Type escape sequence to abort.
```

```
Sending 5, 100-byte ICMP Echos to 1::2, timeout is 2 seconds:
```

```
!!!!!
```

```
Success rate is 100 percent (5/5), round-trip min/avg/max = 20/20/20 ms
```

These steps may be repeated at the other endpoint of the tunnel.

## Configuration Examples for Implementing Tunnels

### Example: Configuring a GRE IPv4 Tunnel

The following example shows a simple configuration of GRE tunneling. Note that TenGigabit Ethernet interface 4/1/0 is the tunnel source for Router A and the tunnel destination for Router B. TenGigabit Ethernet interface 4/1/1 is the tunnel source for Router B and the tunnel destination for Router A.

**Router A**

```
interface Tunnel 0
 ip address 10.1.1.2 255.255.255.0
 tunnel source TenGigabitEthernet 4/1/0
 tunnel destination 192.168.3.2
 tunnel mode gre ip
!
interface TenGigabitEthernet 4/1/0
 ip address 192.168.4.2 255.255.255.0
```

**Router B**

```
interface Tunnel 0
```

```

ip address 10.1.1.1 255.255.255.0
tunnel source TenGigabitEthernet 4/1/1
tunnel destination 192.168.4.2
tunnel mode gre ip
!
interface TenGigabitEthernet 4/1/1
ip address 192.168.3.2 255.255.255.0

```

The following example configures a GRE tunnel running both IS-IS and IPv6 traffic between Router A and Router B:

### Router A

```

ipv6 unicast-routing
clns routing
!
interface Tunnel 0
no ip address
ipv6 address 2001:0DB8:1111:2222::1/64
ipv6 router isis
tunnel source TenGigabitEthernet 4/1/0
tunnel destination 10.0.0.2
tunnel mode gre ip
!
interface TenGigabitEthernet 4/1/0
ip address 10.0.0.1 255.255.255.0
!
router isis
network 49.0000.0000.000a.00

```

### Router B

```

ipv6 unicast-routing
clns routing
!
interface Tunnel 0
no ip address
ipv6 address 2001:0DB8:1111:2222::2/64
ipv6 router isis
tunnel source TenGigabitEthernet 4/1/0
tunnel destination 10.0.0.1
tunnel mode gre ip
!
interface TenGigabitEthernet 4/1/0
ip address 10.0.0.2 255.255.255.0
!
router isis
network 49.0000.0000.000b.00
address-family ipv6
redistribute static
exit-address-family

```

## Configuring QoS Options on Tunnel Interfaces Examples

The following sample configuration applies GTS directly on the tunnel interface. In this example, the configuration shapes the tunnel interface to an overall output rate of 500 kb/s.

```

interface Tunnel 0
ip address 10.1.2.1 255.255.255.0

```

```
traffic-shape rate 500000 125000 125000 1000
tunnel source 10.1.1.1
tunnel destination 10.2.2.2
```

The following sample configuration shows how to apply the same shaping policy to the tunnel interface with the MQC commands:

```
policy-map tunnel
  class class-default
  shape average 500000 125000 125000
!
interface Tunnel 0
  ip address 10.1.2.1 255.255.255.0
  service-policy output tunnel
  tunnel source 10.1.35.1
  tunnel destination 10.1.35.2
```

## Policing Example

When an interface becomes congested and packets start to queue, you can apply a queueing method to packets that are waiting to be transmitted. Logical interfaces--tunnel interfaces in this example--do not inherently support a state of congestion and do not support the direct application of a service policy that applies a queueing method. Instead, you must apply a hierarchical policy. Create a "child" or lower-level policy that configures a queueing mechanism, such as low-latency queueing, with the **priority** command and CBWFQ with the **bandwidth** command.

```
policy-map child
  class voice
  priority 512
```

Create a "parent" or top-level policy that applies class-based shaping. Apply the child policy as a command under the parent policy because admission control for the child class is done according to the shaping rate for the parent class.

```
policy-map tunnel
  class class-default
  shape average 2000000
  service-policy child
```

Apply the parent policy to the tunnel interface.

```
interface tunnel 0
  service-policy tunnel
```

In the following example, a tunnel interface is configured with a service policy that applies queueing without shaping. A log message is displayed noting that this configuration is not supported.

```
Router(config)# interface tunnel1
Router(config-if)# service-policy output child
Class Based Weighted Fair Queueing not supported on this interface
```

# How to Configure IPv6 over IPv4 GRE Tunnels

## Configuring GRE on IPv6 Tunnels

GRE tunnels can be configured to run over an IPv6 network layer and to transport IPv4 and IPv6 packets in IPv6 tunnels.

### Before you begin

When GRE IPv6 tunnels are configured, IPv6 addresses are assigned to the tunnel source and the tunnel destination. The tunnel interface can have either IPv4 addresses or IPv6 addresses assigned (this is not shown in the task). The host or device at each end of a configured tunnel must support both the IPv4 and IPv6 protocol stacks.

### Procedure

|               | Command or Action                                                                                                                                                                                                                                                                                                                                        | Purpose                                                                                                                                                                                                                                                                                                                                                                      |
|---------------|----------------------------------------------------------------------------------------------------------------------------------------------------------------------------------------------------------------------------------------------------------------------------------------------------------------------------------------------------------|------------------------------------------------------------------------------------------------------------------------------------------------------------------------------------------------------------------------------------------------------------------------------------------------------------------------------------------------------------------------------|
| <b>Step 1</b> | <b>enable</b><br><b>Example:</b><br>Device> enable                                                                                                                                                                                                                                                                                                       | Enables privileged EXEC mode. <ul style="list-style-type: none"> <li>• Enter your password if prompted.</li> </ul>                                                                                                                                                                                                                                                           |
| <b>Step 2</b> | <b>configure terminal</b><br><b>Example:</b><br>Device# configure terminal                                                                                                                                                                                                                                                                               | Enters global configuration mode.                                                                                                                                                                                                                                                                                                                                            |
| <b>Step 3</b> | <b>interface tunnel <i>tunnel-number</i></b><br><b>Example:</b><br>Device(config)# interface tunnel 0                                                                                                                                                                                                                                                    | Specifies a tunnel interface and number, and enters interface configuration mode.                                                                                                                                                                                                                                                                                            |
| <b>Step 4</b> | Enter one of the following commands: <ul style="list-style-type: none"> <li>• <b>ipv6 address</b> {<i>ipv6-address/prefix-length</i>   <i>prefix-name sub-bits/prefix-length</i>}</li> <li>• <b>ipv6 address</b> <i>ipv6-prefix/prefix-length</i> [<b>eui-64</b>]</li> </ul> <b>Example:</b><br>Device(config-if)# ipv6 address<br>3ffe:b00:c18:1::3/127 | Specifies the IPv6 network assigned to the interface and enables IPv6 processing on the interface. <ul style="list-style-type: none"> <li>• If you specify the <b>eui-64</b> keyword, the software configures an IPv6 address for an interface and enables IPv6 processing on the interface using an EUI-64 interface ID in the low-order 64 bits of the address.</li> </ul> |
| <b>Step 5</b> | <b>tunnel source</b> { <i>ip-address</i>   <i>ipv6-address</i>   <i>interface-type interface-number</i> }                                                                                                                                                                                                                                                | Specifies the source IPv4 address, IPv6 address, or the source interface type and number for the tunnel interface. <ul style="list-style-type: none"> <li>• If an interface is specified, the interface must be configured with an IPv4 address.</li> </ul> <b>Example:</b><br>Device(config-if)# tunnel source Tengigabitethernet<br>4/1/0                                  |



|        | Command or Action                                                                                                                                                                                                 | Purpose                                                                                                                                         |
|--------|-------------------------------------------------------------------------------------------------------------------------------------------------------------------------------------------------------------------|-------------------------------------------------------------------------------------------------------------------------------------------------|
| Step 6 | <b>tunnel destination</b> {hostname   ip-address   ipv6-address}<br><b>Example:</b><br><pre>Device(config-if)# tunnel destination 2001:DB8:1111:2222::1/64</pre>                                                  | Specifies the destination IPv4 address, IPv6 address, or hostname for the tunnel interface.                                                     |
| Step 7 | <b>tunnel mode</b> {aurp   cayman   dvmrp   eon   gre   gre multipoint   gre ipv6   ipip [decapsulate-any]   iptalk   ipv6   mpls   nos}<br><b>Example:</b><br><pre>Device(config-if)# tunnel mode gre ipv6</pre> | Specifies a GRE IPv6 tunnel.<br><b>Note</b> The <b>tunnel mode gre ipv6</b> command specifies GRE as the encapsulation protocol for the tunnel. |
| Step 8 | <b>end</b><br><b>Example:</b><br><pre>Device(config-if)# end</pre>                                                                                                                                                | Returns to privileged EXEC mode.                                                                                                                |

## Configuration Examples for IPv6 over IPv4 GRE Tunnels

### Example: GRE Tunnel Running IS-IS and IPv6 Traffic

The following example configures a GRE tunnel running both IS-IS and IPv6 traffic between Router A and Router B:

#### Router A Configuration

```
ipv6 unicast-routing
clns routing
!
interface tunnel 0
no ip address
ipv6 address 3ffe:b00:c18:1::3/127
ipv6 router isis
tunnel source TenGigabitEthernet 4/1/0
tunnel destination 2001:DB8:1111:2222::1/64
tunnel mode gre ipv6
!
interface TenGigabitEthernet4/1/0
ip address 10.0.0.1 255.255.255.0
!
router isis
net 49.0000.0000.000a.00
```

#### Router B Configuration

```
ipv6 unicast-routing
clns routing
```

```

!
interface tunnel 0
  no ip address
  ipv6 address 3ffe:b00:c18:1::2/127
  ipv6 router isis
  tunnel source TenGigabitEthernet 4/1/0
  tunnel destination 2001:DB8:1111:2222::2/64
  tunnel mode gre ipv6
!
interface TenGigabitEthernet4/1/0
  ip address 10.0.0.2 255.255.255.0
!
router isis
  net 49.0000.0000.000b.00
  address-family ipv6
  redistribute static
  exit-address-family

```

## Example: Tunnel Destination Address for IPv6 Tunnel

```

Router(config)#interface Tunnel0
Router(config-if)#ipv6 address 2001:1:1::1/48
Router(config-if)#tunnel source TenGigabitEthernet 4/1/0
Router(config-if)#tunnel destination 10.0.0.2
Router(config-if)#tunnel mode gre ipv6
Router(config-if)#exit
!
Router(config)#interface TenGigabitEthernet4/1/0
Router(config-if)#ip address 10.0.0.1 255.255.255.0
Router(config-if)#exit
!
Router(config)#ipv6 unicast-routing
Router(config)#router isis
Router(config)#net 49.0000.0000.000a.00

```

# How to Configure GRE IPv6 Tunnels

## Configure CDP Over GRE IPv6 Tunnels

Perform this task to configure a GRE tunnel on an IPv6 network. GRE tunnels can be configured to run over an IPv6 network layer and transport IPv6 and IPv4 packets through IPv6 tunnels.



---

**Note** You must enable IPv6 or configure IPv6 MTU size more than 1500 on a tunnel's exit interface to avoid receiving warning messages.

---

### Before you begin

When GRE IPv6 tunnels are configured, IPv6 addresses are assigned to the tunnel source and the tunnel destination. The tunnel interface can have either IPv4 or IPv6 addresses. The host or device at each end of the configured tunnel must support both IPv4 and IPv6 protocol stacks.

## Procedure

|               | Command or Action                                                                                                                                               | Purpose                                                                                                                                                                                                                                                                                                                                                                     |
|---------------|-----------------------------------------------------------------------------------------------------------------------------------------------------------------|-----------------------------------------------------------------------------------------------------------------------------------------------------------------------------------------------------------------------------------------------------------------------------------------------------------------------------------------------------------------------------|
| <b>Step 1</b> | <b>enable</b><br><b>Example:</b><br>Device> enable                                                                                                              | Enables privileged EXEC mode.<br><ul style="list-style-type: none"><li>• Enter your password if prompted.</li></ul>                                                                                                                                                                                                                                                         |
| <b>Step 2</b> | <b>configure terminal</b><br><b>Example:</b><br>Device# configure terminal                                                                                      | Enters global configuration mode.                                                                                                                                                                                                                                                                                                                                           |
| <b>Step 3</b> | <b>interface tunnel <i>tunnel-number</i></b><br><b>Example:</b><br>Device(config)# interface tunnel 0                                                           | Specifies a tunnel interface and number and enters interface configuration mode.                                                                                                                                                                                                                                                                                            |
| <b>Step 4</b> | <b>CDP enable</b><br><b>Example:</b><br>Device(config)# CDP enable                                                                                              | Enables Cisco Discovery Protocol on the interface.                                                                                                                                                                                                                                                                                                                          |
| <b>Step 5</b> | <b>tunnel source {<i>ipv6-address</i>   <i>interface-type</i>   <i>interface-number</i> }</b><br><b>Example:</b><br>Device(config-if)# tunnel source ethernet 0 | Specifies the source IPv6 address or the source interface type and number for the tunnel interface.<br><ul style="list-style-type: none"><li>• If an interface type and number are specified, the interface must be configured with an IPv6 address.</li></ul><br><b>Note</b> For more information on the tunnel source command, refer to the IPv6 command reference guide. |
| <b>Step 6</b> | <b>tunnel destination <i>ipv6-address</i></b><br><b>Example:</b><br>Device(config-if)# tunnel destination 2001:0DB8:0C18:2::300                                 | Specifies the destination IPv6 address for the tunnel interface.<br><br><b>Note</b> For more information on the tunnel destination command, refer to the IPv6 command reference guide.                                                                                                                                                                                      |
| <b>Step 7</b> | <b>tunnel mode gre ipv6</b><br><b>Example:</b><br>Device(config-if)# tunnel mode gre ipv6                                                                       | Specifies a GRE IPv6 tunnel.<br><br><b>Note</b> The <b>tunnel mode gre ipv6</b> command specifies GRE as the encapsulation protocol for the tunnel interface. Only the syntax used in this context is displayed. For more details, see the <a href="#">IPv6 Command Reference</a> .                                                                                         |
| <b>Step 8</b> | <b>end</b><br><b>Example:</b><br>Device(config-if)# end                                                                                                         | Exits interface configuration mode and returns to privileged EXEC mode.                                                                                                                                                                                                                                                                                                     |

# Configuration Examples for GRE IPv6 Tunnels

## Example: Configuring CDP Over GRE IPv6 Tunnels

The following example shows how to configure a GRE tunnel over an IPv6 transport. In this example, Ethernet0/0 has an IPv6 address, and this is the source address used by the tunnel interface. The destination IPv6 address of the tunnel is specified directly. In this example, the tunnel carries both IPv4 and IS-IS traffic.

```
interface Tunnel0
 ip address 10.1.1.1 255.255.255.0
 ip router isis
 tunnel source Ethernet0/0
 tunnel destination 2001:DB8:1111:2222::1
 tunnel mode gre ipv6
!
interface Ethernet0/0
 no ip address
 ipv6 address 2001:DB8:1111:1111::1/64
!
router isis
 net 49.0001.0000.0000.000a.00
```

The following example shows how to configure CDP on GRE IPv6 P2P Tunnel Interface.

```
interface Tunnell
 cdp enable
 ipv6 address 20::1/64
 tunnel source Ethernet0/0
 tunnel mode gre ipv6
 tunnel destination 10::2
end
```

The following example shows how to configure CDP on GRE IPv6 Multipoint Tunnel Interface.

```
interface Tunnell
 ipv6 address 172::2/64
 ipv6 nhrp map 172::1/64 192::1
 ipv6 nhrp map multicast 192::1
   ipv6 nhrp network-id 1
 ipv6 nhrp nhs 172::1
 llp nhrp map multicast 192::1
 tunnel source 2000::1
 tunnel mode gre multipoint ipv6
end
```

The following show example displays the CDP neighbor tunnels that are configured in a device.

```
Router#show cdp neighbors
Capability Codes: R - Router, T - Trans Bridge, B - Source Route Bridge
                  S - Switch, H - Host, I - IGMP, r - Repeater, P - Phone,
                  D - Remote, C - CVTA, M - Two-port Mac Relay

Device ID         Local Intrfce   Holdtme    Capability  Platform  Port ID
Router            Tunnell        179        R           Linux Uni  Tunnell
```

## Additional References

The following sections provide references related to the GRE feature.

**Related Documents**

| Related Topic                     | Document Title                                                                                                                                                                                                                                                              |
|-----------------------------------|-----------------------------------------------------------------------------------------------------------------------------------------------------------------------------------------------------------------------------------------------------------------------------|
| CMTS Command Reference            | Cisco CMTS Cable Command Reference, at the following URL:<br><a href="http://www.cisco.com/c/en/us/td/docs/cable/cmts/cmd_ref/b_cmts_cable_cmd_ref.html">http://www.cisco.com/c/en/us/td/docs/cable/cmts/cmd_ref/b_cmts_cable_cmd_ref.html</a>                              |
| Configuring GRE Tunnel over Cable | Configuring GRE Tunnel over Cable, at the following URL:<br><a href="http://www.cisco.com/en/US/tech/tk86/tk89/technologies_configuration_example09186a008011520d.sht">http://www.cisco.com/en/US/tech/tk86/tk89/technologies_configuration_example09186a008011520d.sht</a> |

**Standards**

| Standard                              | Title                                                                                                                                                                       |
|---------------------------------------|-----------------------------------------------------------------------------------------------------------------------------------------------------------------------------|
| <a href="#">SP-RFIV1.1-109-020830</a> | Data-over-Cable Service Interface Specifications Radio Frequency Interface Specification, version 1.1 ( <a href="http://www.cablemodem.com">http://www.cablemodem.com</a> ) |

**MIBs**

| MIB                                                    | MIBs Link                                                                                                                                                                                                                                                        |
|--------------------------------------------------------|------------------------------------------------------------------------------------------------------------------------------------------------------------------------------------------------------------------------------------------------------------------|
| No new or modified MIBs are supported by this feature. | To locate and download MIBs for selected platforms, Cisco IOS releases, and feature sets, use Cisco MIB Locator found at the following URL:<br><br><a href="http://tools.cisco.com/ITDIT/MIBS/servlet/index">http://tools.cisco.com/ITDIT/MIBS/servlet/index</a> |

**RFCs**

| RFC      | Title                                                            |
|----------|------------------------------------------------------------------|
| RFC 1701 | <a href="#">Generic Routing Encapsulation (GRE)</a>              |
| RFC 1702 | <a href="#">Generic Routing Encapsulation over IPv4 networks</a> |
| RFC 1853 | <a href="#">IP in IP Tunneling</a>                               |
| RFC 2003 | <a href="#">IP Encapsulation within IP</a>                       |
| RFC 2784 | <a href="#">Generic Routing Encapsulation (GRE)</a>              |
| RFC 2890 | <a href="#">Key and Sequence Number Extensions to GRE</a>        |

**Technical Assistance**

| Description                                                                                                                                                                                                                                                                         | Link                                                                                                              |
|-------------------------------------------------------------------------------------------------------------------------------------------------------------------------------------------------------------------------------------------------------------------------------------|-------------------------------------------------------------------------------------------------------------------|
| The Cisco Technical Support & Documentation website contains thousands of pages of searchable technical content, including links to products, technologies, solutions, technical tips, and tools. Registered Cisco.com users can log in from this page to access even more content. | <a href="http://www.cisco.com/cisco/web/support/index.html">http://www.cisco.com/cisco/web/support/index.html</a> |

## Feature Information for Generic Routing Encapsulation

Use Cisco Feature Navigator to find information about the platform support and software image support. Cisco Feature Navigator enables you to determine which software images support a specific software release, feature set, or platform. To access Cisco Feature Navigator, go to the <https://cfng.cisco.com/> link. An account on the Cisco.com page is not required.



**Note** The following table lists the software release in which a given feature is introduced. Unless noted otherwise, subsequent releases of that software release train also support that feature.

**Table 103: Feature Information for Generic Routing Encapsulation**

| Feature Name                  | Releases                 | Feature Information                                                              |
|-------------------------------|--------------------------|----------------------------------------------------------------------------------|
| Generic Routing Encapsulation | Cisco IOS XE Fuji 16.7.1 | This feature was integrated on the Cisco cBR Series Converged Broadband Routers. |



## CHAPTER 28

# Transparent LAN Service over Cable

This document describes the Transparent LAN Service (TLS) over Cable feature, which enhances existing Wide Area Network (WAN) support to provide more flexible Managed Access for multiple Internet service provider (ISP) support over a hybrid fiber-coaxial (HFC) cable network. This feature allows service providers to create a Layer 2 tunnel by mapping an upstream service identifier (SID) to an IEEE 802.1Q Virtual Local Area Network (VLAN).

Your software release may not support all the features that are documented in this module. For the latest feature information and caveats, see the release notes for your platform and software release. The Feature Information Table at the end of this document provides information about the documented features and lists the releases in which each feature is supported.

Use Cisco Feature Navigator to find information about platform support and Cisco software image support. To access Cisco Feature Navigator, go to <http://tools.cisco.com/ITDIT/CFN/>. An account on <http://www.cisco.com/> is not required.

### Contents

- [Hardware Compatibility Matrix for the Cisco cBR Series Routers, on page 523](#)
- [Prerequisites for Transparent LAN Service over Cable, on page 525](#)
- [Restrictions for Transparent LAN Service over Cable, on page 525](#)
- [Information About Transparent LAN Service over Cable, on page 526](#)
- [How to Configure the Transparent LAN Service over Cable, on page 528](#)
- [Configuration Examples for Transparent LAN Service over Cable, on page 530](#)
- [Verifying the Transparent LAN Service over Cable Configuration, on page 532](#)
- [Additional References, on page 533](#)
- [Feature Information for Transparent LAN Service over Cable , on page 533](#)

## Hardware Compatibility Matrix for the Cisco cBR Series Routers



---

**Note** The hardware components that are introduced in a given Cisco IOS-XE Release are supported in all subsequent releases unless otherwise specified.

---

Table 104: Hardware Compatibility Matrix for the Cisco cBR Series Routers

| Cisco CMTS Platform                    | Processor Engine                                                                                                                                                                                  | Interface Cards                                                                                                                                                                                                                                                                                                                                                                                                                                                                                                                                                                                                                                                                                                                                                                                 |
|----------------------------------------|---------------------------------------------------------------------------------------------------------------------------------------------------------------------------------------------------|-------------------------------------------------------------------------------------------------------------------------------------------------------------------------------------------------------------------------------------------------------------------------------------------------------------------------------------------------------------------------------------------------------------------------------------------------------------------------------------------------------------------------------------------------------------------------------------------------------------------------------------------------------------------------------------------------------------------------------------------------------------------------------------------------|
| Cisco cBR-8 Converged Broadband Router | <p><b>Cisco IOS-XE Release 16.5.1 and Later Releases</b></p> <p>Cisco cBR-8 Supervisor:</p> <ul style="list-style-type: none"> <li>• PID—CBR-SUP-250G</li> <li>• PID—CBR-CCAP-SUP-160G</li> </ul> | <p><b>Cisco IOS-XE Release 16.5.1 and Later Releases</b></p> <p>Cisco cBR-8 CCAP Line Cards:</p> <ul style="list-style-type: none"> <li>• PID—CBR-LC-8D30-16U30</li> <li>• PID—CBR-LC-8D31-16U30</li> <li>• PID—CBR-RF-PIC</li> <li>• PID—CBR-RF-PROT-PIC</li> <li>• PID—CBR-CCAP-LC-40G</li> <li>• PID—CBR-CCAP-LC-40G-R</li> <li>• PID—CBR-CCAP-LC-G2-R</li> <li>• PID—CBR-SUP-8X10G-PIC</li> <li>• PID—CBR-2X100G-PIC</li> </ul> <p>Digital PICs:</p> <ul style="list-style-type: none"> <li>• PID—CBR-DPIC-8X10G</li> <li>• PID—CBR-DPIC-2X100G</li> </ul> <p>Cisco cBR-8 Downstream PHY Module:</p> <ul style="list-style-type: none"> <li>• PID—CBR-D31-DS-MOD</li> </ul> <p>Cisco cBR-8 Upstream PHY Modules:</p> <ul style="list-style-type: none"> <li>• PID—CBR-D31-US-MOD</li> </ul> |



**Note** Do not use DPICs (8X10G and 2x100G) to forward IP traffic, as it may cause buffer exhaustion, leading to line card reload.

The only allowed traffic on a DPIC interface is DEPI, UEPI, and GCP traffic from the Cisco cBR-8 router to Remote PHY devices. Other traffic such as DHCP, SSH, and UTSC should flow via another router, since DPICs cannot be used for normal routing.



## Prerequisites for Transparent LAN Service over Cable

- You must know the hardware (MAC) addresses of the cable modems that are to be mapped to IEEE 802.1Q VLANs.
- You must create a bridge group for each separate customer on the Layer 2 bridge aggregator, so that traffic from all of the Customer Premises Equipment (CPE) devices for the customer is grouped together into the same 802.1Q tunnel.

## Restrictions for Transparent LAN Service over Cable

- Configuring 802.1Q for a particular cable modem removes any previous cable modem configuration on the router.
- We strongly recommend that TLS over Cable only be used when Baseline Privacy Interface (BPI) is enabled in the environment. If BPI is not enabled when using the TLS feature, traffic can flow between multiple virtual private networks (VPNs), and become vulnerable to denial-of-service attacks or snooping. We also recommend that remote networks be isolated with a gateway or firewall router when BPI is not enabled.

When the TLS feature is used with Layer 2 VPNs, the participating cable modems *must* have the Baseline Privacy Interface security feature (BPI) enabled. Otherwise, the Cisco CMTS drops such Layer 2 traffic in the upstream or downstream.

- Packets are mapped to their Layer 2 tunnel only on the basis of Layer 2 information (the cable modem's MAC address and primary SID). Layer 3 services, such as access lists, IP address source-verify, and IP QoS, are not supported as packets are sent through the tunnel.
- All traffic from a cable modem is mapped to the same Layer 2 tunnel. It is not possible to differentiate traffic from different customer premises equipment (CPE) devices behind the cable modem.
- CPE learning is not available when using the Transparent LAN Service over Cable feature. When a cable modem is mapped to a Layer 2 tunnel, the **show interface cable modem** command shows that the IP addresses for its CPE devices are "unavailable."
- DOCSIS QoS is supported across the Layer 2 tunnel only on the primary SID. Traffic using secondary services uses the same Layer 2 tunnel as the primary SID.
- The Spanning Tree Protocol (STP) cannot be used with devices (cable modems, their CPE devices, and the endpoint CPE devices) that are using this feature. In particular, Spanning Tree Protocol cannot be used between the VLAN bridge aggregator and the endpoint customer devices.
- The following restrictions apply to Layer 2 tunnels over an Ethernet IEEE 802.1Q VLAN interface:
  - IEEE 802.1Q tunnels are supported only on Ten Gigabit Ethernet interfaces.
  - The Cisco CMTS router supports a maximum of 4095 VLAN IDs, but the switches acting as the bridge aggregator might support a lower number of VLAN IDs. If this is the case, the Cisco CMTS should be configured only for the maximum number of VLANs that are supported by the bridge aggregator switches.

# Information About Transparent LAN Service over Cable

This section contains the following:

## Feature Overview

The Transparent LAN Service over Cable feature enables service providers to provide Layer 2 tunnels for traffic to and from cable modems. This allows customers to create their own virtual local area network (VLAN) using any number of cable modems in multiple sites.

On the Cisco CMTS, you map each cable modem (on the basis of its MAC address) to the appropriate VLAN. The CMTS then creates an internal database of this one-to-one mapping of cable modems to VLANs, and uses it to encapsulate packets for the appropriate VLAN.

The CMTS encapsulates the CPE traffic from mapped cable modems using the following method:

- **IEEE 802.1Q Mapping**—The cable modem's MAC address is mapped to an IEEE 802.1Q VLAN on a specific Ten Gigabit Ethernet interface, so that all traffic from the cable modem is tagged with the specified VLAN ID.

Traffic to and from this group of cable modems is bridged into a single logical network (the VLAN) by the bridge aggregator, creating a secure Virtual Private Network (VPN) for that particular group of cable modems. Traffic in one VLAN cannot be sent into another VLAN, unless specifically done so by an external router.

The switch acting as the Layer 2 Bridge Aggregator uses the VLAN tagging to forward the traffic to the appropriate destination. This frees up service providers from needing to know the addressing, routing, and topological details of the customer's network.

## Transparent LAN Service and Layer 2 Virtual Private Networks

In addition, service providers can provide a Layer 2 VPN with only minimal configuration changes on the provider's routers. The service subscriber does not need to make any changes to their private network or cable modems, nor does the service provider have to provide any special DOCSIS configuration files to enable this feature.

For the TLS feature with Layer 2 VPNs:

- When the TLS feature is used with Layer 2 VPNs, the participating cable modems must have the Baseline Privacy Interface security feature (BPI) enabled. Otherwise, the Cisco CMTS drops such Layer 2 traffic in the upstream or downstream.
- Information about Customer Premises Equipment (CPE) does not display in the output of the **show cable modem** command.

## IEEE 802.1Q Mapping

This section describes the mapping of cable modems to an IEEE 802.1Q VLAN, as it is available in the Transparent LAN Service over Cable feature:

## Overview

The Transparent LAN Service over Cable feature enables service providers to provide Layer 2 tunnels over an Ethernet network, using IEEE 802.1Q standard tags. This allows customers to create their own virtual network using any number of cable modems in different sites.

On the Cisco CMTS, you map each cable modem (on the basis of its MAC address) to the appropriate VLAN. The CMTS then creates an internal database of this one-to-one mapping of cable modems to VLANs, and uses it to encapsulate packets for the appropriate VLAN.

The CMTS encapsulates the CPE traffic from mapped cable modems using VLAN tags, as defined in [IEEE 802.1Q-1993, IEEE Standards for Local and Metropolitan Area Networks: Virtual Bridged Local Area Networks](#). The switch acting as the Layer 2 Bridge Aggregator uses the VLAN tagging to forward the packets to the appropriate destination.

Traffic to and from this group of cable modems is bridged into a single logical network by the bridge aggregator, creating a secure Virtual Private Network (VPN) for that particular group of cable modems. Traffic in one VLAN cannot be sent into another VLAN, unless specifically done so by an external router.

## Details of IEEE 802.1Q Mapping

To implement the Transparent LAN Service over Cable feature using IEEE 802.1Q VLANs, a service provider must perform the following configuration steps:

1. Identify the cable modems and their MAC addresses that should be mapped to the IEEE 802.1Q VLANs.
2. Create the required VLANs on the router that is acting as the bridge aggregator.
3. Enable Layer 2 mapping on the Cisco CMTS, and then map each cable modem on that Cisco CMTS to the appropriate VLAN.

After the Transparent LAN Service over Cable feature has been enabled and configured to use IEEE 802.1Q mappings, the Cisco CMTS immediately begins mapping traffic between the associated cable modems and VLANs. For efficient mapping, the Cisco CMTS maintains an internal database that links each cable modem's primary service flow ID (SFID) and service ID (SID) to the appropriate VLAN and Ethernet interface. This ensures that all service flows from the cable modem are routed properly.

When the Cisco CMTS receives a packet on an upstream, it looks up its SID to see if it is mapped to a VLAN. If so, and if the packet's source MAC address is not the cable modem's MAC address, the Cisco CMTS inserts the appropriate IEEE 802.1Q VLAN tag into the packet's header and forwards the packet to the appropriate Ethernet interface. If the packet is not being mapped, or if the packet originated from the cable modem, the Cisco CMTS routes the packet using the normal Layer 3 processes.

When the Cisco CMTS receives a packet from a WAN interface that is encapsulated with an IEEE 802.1Q VLAN tag, it looks up the packet's SID to see if it belongs to a cable modem being mapped. If so, the Cisco CMTS strips off the VLAN tag, adds the proper DOCSIS header, and transmits the packet on the appropriate downstream interface. If the packet is not being mapped, the Cisco CMTS continues with the normal Layer 3 processing.

## Benefits

The Transparent LAN Service over Cable feature provides the following benefits to cable service providers and their partners and customers:

- Provides Layer 2 level mapping, which is transparent to Layer 3 protocols and services. This means that service providers do not need to know the details of their customers' network topologies, routing protocols, or IP addressing.

- Allows service providers to maximize the use of their existing Ethernet WAN networks. Multiple customers can be combined on the same outgoing interface, while still ensuring that each customer's network is kept private while it is transmitted over the tunnel.
- Provides a highly flexible and scalable solution for multiple customers. The service provider needs to create only one bridge group for each VPN, and then only one VLAN mapping for each cable modem should participate in that VPN tunnel.
- Customers retain full control over their private networks, while service providers retain full control over cable modems and the rest of the cable and WAN networks. Only the CPE traffic from the cable modems is mapped into the L2VPN tunnel, while traffic originating at the cable modem continues to be processed as normal by the service provider's network.
- Allows service providers to mix tunneled and non-tunneled cable modems on the same DOCSIS cable network.
- Allows customers to create a single, secure virtual network with Ethernet Layer 2 connectivity for multiple sites.
- Allows multiple tunnels from different customers and endpoints to be aggregated into a single bridge, so as to maximize the use of bandwidth and other network resources.
- Supports the tunneling of multiple Layer 3, non-IP protocols, and not just IP Layer 3 services, as is the case with Layer 3 solutions, such as Multiprotocol Label Switching (MPLS) VPNs.
- All DOCSIS services, including BPI+ encryption and authentication, continue to be supported for all cable modems.

## How to Configure the Transparent LAN Service over Cable

This section contains the following:

### Configuring IEEE 802.1Q VLAN Mapping

This section describes how to enable Layer 2 mapping on the Cisco CMTS, and then to map particular cable modems to an IEEE 802.1Q VLAN.

### Enabling and Configuring Layer 2 Tunneling for IEEE 802.1Q Mapping

This section describes how to enable Layer 2 mapping on the Cisco CMTS, and then to map particular cable modems to IEEE 802.1Q VLANs on a Ten Gigabit Ethernet interface.

#### Procedure

|               | Command or Action                                                          | Purpose                                                        |
|---------------|----------------------------------------------------------------------------|----------------------------------------------------------------|
| <b>Step 1</b> | <b>enable</b><br><b>Example:</b><br>Router> enable                         | Enables privileged EXEC mode. Enter your password if prompted. |
| <b>Step 2</b> | <b>configure terminal</b><br><b>Example:</b><br>Router# configure terminal | Enters global configuration mode.                              |

|               | Command or Action                                                                                                                                                                           | Purpose                                                                                                                                                                                                                                      |
|---------------|---------------------------------------------------------------------------------------------------------------------------------------------------------------------------------------------|----------------------------------------------------------------------------------------------------------------------------------------------------------------------------------------------------------------------------------------------|
| <b>Step 3</b> | <b>cable l2-vpn-service xconnect nsi dot1q</b><br><b>Example:</b><br><pre>Router(config)# cable l2-vpn-service xconnect nsi dot1q</pre>                                                     | Enables Layer 2 tunneling for IEEE 802.1Q VLAN mapping.<br><b>Note</b> It is not required to configure VLAN trunking on the Cisco CMTS. Though VLAN trunking is supported, be aware of additional impact of VLAN trunking on the Cisco CMTS. |
| <b>Step 4</b> | <b>cable dot1q-vc-map mac-address ethernet-interface vlan-id [cust-name ]</b><br><b>Example:</b><br><pre>Router(config)# cable dot1q-vc-map 0000.0C04.0506 TenGigabitEthernet4/1/0 10</pre> | Maps the specified MAC address of a cable modem to the indicated VLAN and Ten Gigabit Ethernet interface.<br><b>Note</b> Repeat this command for each cable modem that is to be mapped to an IEEE 802.1Q VLAN.                               |
| <b>Step 5</b> | <b>end</b><br><b>Example:</b><br><pre>Router(config)# end</pre>                                                                                                                             | Exits global configuration mode and returns to privileged EXEC mode.                                                                                                                                                                         |

## Creating the IEEE 802.1Q VLAN Bridge Group

This section describes the minimum configuration needed to configure a Cisco router, which is acting as an IEEE 802.1Q VLAN bridge aggregator, so that it can terminate the VLANs being used with the Transparent LAN Service over Cable feature.

### Procedure

|               | Command or Action                                                                                                                        | Purpose                                                                     |
|---------------|------------------------------------------------------------------------------------------------------------------------------------------|-----------------------------------------------------------------------------|
| <b>Step 1</b> | <b>enable</b><br><b>Example:</b><br><pre>Router&gt; enable</pre>                                                                         | Enables privileged EXEC mode. Enter your password if prompted.              |
| <b>Step 2</b> | <b>configure terminal</b><br><b>Example:</b><br><pre>Router# configure terminal</pre>                                                    | Enters global configuration mode.                                           |
| <b>Step 3</b> | <b>interface TenGigabitEthernet slot/subslot/port</b><br><b>Example:</b><br><pre>Router(config)# interface TenGigabitEthernet4/1/0</pre> | Enters interface configuration mode for the Ten Gigabit Ethernet interface. |
| <b>Step 4</b> | <b>ip address ip-address mask</b><br><b>Example:</b>                                                                                     | Configures the interface with the specified IP address and subnet mask.     |

|               | Command or Action                                                                                                                         | Purpose                                                                                                                                                                                                                                                                                                                                                              |
|---------------|-------------------------------------------------------------------------------------------------------------------------------------------|----------------------------------------------------------------------------------------------------------------------------------------------------------------------------------------------------------------------------------------------------------------------------------------------------------------------------------------------------------------------|
|               | Router(config-if)# ip address 10.10.10.85<br>255.255.255.0                                                                                |                                                                                                                                                                                                                                                                                                                                                                      |
| <b>Step 5</b> | <b>exit</b><br><b>Example:</b><br><br>Router(config-if)# exit                                                                             | Exits interface configuration and returns to global configuration mode.                                                                                                                                                                                                                                                                                              |
| <b>Step 6</b> | <b>interface TenGigabitEthernet slot/subslot/port.y</b><br><b>Example:</b><br><br>Router(config)# interface<br>TenGigabitEthernet4/1/0.10 | Creates a subinterface on the Ten Gigabit Ethernet interface.<br><br><b>Note</b> To simplify network management, set the subinterface number to the same value as the VLAN ID that will use this subinterface (which in this case is 10).<br><br><b>Note</b> The steps to create a subinterface is not essential for dot1q tagging of frames, but it is recommended. |
| <b>Step 7</b> | <b>bridge group number</b><br><b>Example:</b><br><br>Router(config-if)# bridge group 20                                                   | Configures this subinterface to belong to the specified bridge group.<br><br><b>Note</b> Repeat steps Step 5 through Step 7 for each subinterface to be created and bridged.                                                                                                                                                                                         |
| <b>Step 8</b> | <b>end</b><br><b>Example:</b><br><br>Router(config-if)# end                                                                               | Exits interface configuration mode and returns to privileged EXEC mode.                                                                                                                                                                                                                                                                                              |

## Configuration Examples for Transparent LAN Service over Cable

This section lists sample configurations for the Transparent LAN Service over Cable feature on a CMTS router and on a Cisco router acting as a bridge aggregator:

### Example: Configuring IEEE 802.1Q VLAN Mapping

The following partial configuration shows a typical configuration that shows a number of cable modems being mapped to two different IEEE 802.1Q VLANs.

```

cable l2-vpn-service xconnect nsi dot1q
! Customer 1
cable dot1q-vc-map 000C.0e03.69f9 TenGigabitEthernet 4/1/0 10 Customer1
cable dot1q-vc-map 0010.7bea.9c95 TenGigabitEthernet 4/1/0 11 Customer1
cable dot1q-vc-map 0010.7bed.81c2 TenGigabitEthernet 4/1/0 12 Customer1
cable dot1q-vc-map 0010.7bed.9b1a TenGigabitEthernet 4/1/0 13 Customer1
! Customer 2
cable dot1q-vc-map 0002.fdfa.137d TenGigabitEthernet 4/1/0 20 Customer2
cable dot1q-vc-map 0006.28f9.9d19 TenGigabitEthernet 4/1/0 21 Customer2
cable dot1q-vc-map 000C.7b6b.58c1 TenGigabitEthernet 4/1/0 22 Customer2
cable dot1q-vc-map 000C.7bed.9dbb TenGigabitEthernet 4/1/0 23 Customer2

```

```

cable dot1q-vc-map 000C.7b43.aa7f TenGigabitEthernet 4/1/0 24 Customer2
cable dot1q-vc-map 0050.7302.3d83 TenGigabitEthernet 4/1/0 25 Customer2
...

```

## Example: Configuring IEEE 802.1Q Bridge Aggregator

The following example shows a router being used as a bridge aggregator to transmit VLANs across the same Ten Gigabit Ethernet interface, using IEEE 802.1Q tagging.

```

!
interface TenGigabitEthernet4/1/0
 ip address 10.10.10.31 255.255.255.0
 duplex full
 speed auto
!
interface TenGigabitEthernet4/1/0.10
 description Customer1-site10
 encapsulation dot1Q 10
 bridge-group 200
interface TenGigabitEthernet4/1/0.11
 description Customer1-site11
 encapsulation dot1Q 11
 bridge-group 200
interface TenGigabitEthernet4/1/0.12
 description Customer1-site12
 encapsulation dot1Q 12
 bridge-group 200
interface TenGigabitEthernet4/1/0.13
 description Customer1-site13
 encapsulation dot1Q 13
 bridge-group 200
!-----
interface TenGigabitEthernet4/1/0.20
 description Customer2-site20
 encapsulation dot1Q 20
 bridge-group 201
interface TenGigabitEthernet4/1/0.21
 description Customer2-site21
 encapsulation dot1Q 21
 bridge-group 201
interface TenGigabitEthernet4/1/0.22
 description Customer2-site22
 encapsulation dot1Q 22
 bridge-group 201
interface TenGigabitEthernet4/1/0.23
 description Customer2-site23
 encapsulation dot1Q 23
 bridge-group 201
interface TenGigabitEthernet4/1/0.24
 description Customer2-site24
 encapsulation dot1Q 24
 bridge-group 201
interface TenGigabitEthernet4/1/0.25
 description Customer2-site25
 encapsulation dot1Q 25
 bridge-group 201
!
bridge 200 protocol ieee
bridge 201 protocol ieee
...

```

## Verifying the Transparent LAN Service over Cable Configuration

- **show cable l2-vpn xconnect dot1q-vc-map**—Displays the mapping information of the cable modems to IEEE 802.1Q VLANs.

Following is a sample output of the command:

```
Router# show cable l2-vpn xconnect dot1q-vc-map

MAC Address      Ethernet Interface      VLAN ID  Cable Intf  SID  Customer Name/VPNID
38c8.5cac.4a62   TenGigabitEthernet4/1/2  56      Cable3/0/0  4    Customer2
38c8.5cfe.f6fa   TenGigabitEthernet4/1/2  34      Cable3/0/0  3    Customer1
602a.d083.2e1c   TenGigabitEthernet4/1/4  43      Cable3/0/0  5    Customer3
```

- **show cable l2-vpn xconnect dot1q-vc-map customer name**—Displays the mapping information of the cable modems to IEEE 802.1Q VLANs for the specified customer name.

Following is a sample output of the command.

```
Router# show cable l2-vpn xconnect dot1q-vc-map customer Customer1

MAC Address      Ethernet Interface      VLAN ID  Cable Intf  SID  Customer Name/VPNID
38c8.5cfe.f6fa   TenGigabitEthernet4/1/2  34      Cable3/0/0  3    Customer1
```

- **show cable l2-vpn xconnect dot1q-vc-map mac-address**—Displays the mapping information of the cable modems to IEEE 802.1Q VLANs for the specified MAC address.

Following is a sample output of the command:

```
Router# show cable l2-vpn xconnect dot1q-vc-map 38c8.5cac.4a62

MAC Address      Ethernet Interface      VLAN ID  Cable Intf  SID  Customer Name/VPNID
38c8.5cac.4a62   TenGigabitEthernet4/1/2  56      Cable3/0/0  4    Customer2
```

- **show cable l2-vpn xconnect dot1q-vc-map mac-address verbose**—Displays additional information about the Layer 2 mapping, including the number of packets and bytes received on the upstream and downstream.

Following is a sample output of the command:

```
Router# show cable l2-vpn xconnect dot1q-vc-map 38c8.5cac.4a62 verbose

MAC Address          : 38c8.5cac.4a62
Customer Name       : Customer2
Prim Sid            : 4
Cable Interface     : Cable3/0/0
Ethernet Interface  : TenGigabitEthernet4/1/2
DOT1Q VLAN ID      : 56
Total US pkts      : 1
Total US bytes     : 342
Total DS pkts      : 4
Total DS bytes     : 512
```



## Additional References

### Standards

| Standards                 | Title                                                                                        |
|---------------------------|----------------------------------------------------------------------------------------------|
| SP-RFIV1.1-I08-020301     | Data-over-Cable Service Interface Specifications Radio Frequency Interface Specification     |
| IEEE 802.1Q, 1998 Edition | IEEE Standards for Local and Metropolitan Area Networks: Virtual Bridged Local Area Networks |

### RFCs

| RFCs <sup>2</sup>        | Title                                                                      |
|--------------------------|----------------------------------------------------------------------------|
| <a href="#">RFC 1163</a> | <a href="#">A Border Gateway Protocol</a>                                  |
| <a href="#">RFC 1164</a> | <a href="#">Application of the Border Gateway Protocol in the Internet</a> |
| <a href="#">RFC 2233</a> | <a href="#">DOCSIS OSSI Objects Support</a>                                |
| <a href="#">RFC 2283</a> | <a href="#">Multiprotocol Extensions for BGP-4</a>                         |
| <a href="#">RFC 2665</a> | <a href="#">DOCSIS Ethernet MIB Objects Support</a>                        |
| <a href="#">RFC 2669</a> | <a href="#">Cable Device MIB</a>                                           |

<sup>2</sup> Not all supported RFCs are listed.

### Technical Assistance

| Description                                                                                                                                                                                                                                                              | Link                                                                                                              |
|--------------------------------------------------------------------------------------------------------------------------------------------------------------------------------------------------------------------------------------------------------------------------|-------------------------------------------------------------------------------------------------------------------|
| Technical Assistance Center (TAC) home page, containing 30,000 pages of searchable technical content, including links to products, technologies, solutions, technical tips, and tools. Registered Cisco.com users can log in from this page to access even more content. | <a href="http://www.cisco.com/cisco/web/support/index.html">http://www.cisco.com/cisco/web/support/index.html</a> |

## Feature Information for Transparent LAN Service over Cable

Use Cisco Feature Navigator to find information about the platform support and software image support. Cisco Feature Navigator enables you to determine which software images support a specific software release, feature set, or platform. To access Cisco Feature Navigator, go to the <https://cfmng.cisco.com/> link. An account on the Cisco.com page is not required.



**Note** The following table lists the software release in which a given feature is introduced. Unless noted otherwise, subsequent releases of that software release train also support that feature.

**Table 105: Feature Information for Upstream Channel Bonding**

| Feature Name                       | Releases                 | Feature Information                                                             |
|------------------------------------|--------------------------|---------------------------------------------------------------------------------|
| Transparent LAN Service over Cable | Cisco IOS XE Fuji 16.7.1 | This feature was integrated on the Cisco cBR Series Converged Broadband Router. |



## CHAPTER 29

# Downgrading Channel Bonding in Battery Backup Mode

---

Cisco CMTS supports downgrading the channel bonding for cable modems and media terminal adapters (MTAs) in battery backup mode.

Your software release may not support all the features that are documented in this module. For the latest feature information and caveats, see the release notes for your platform and software release. The Feature Information Table at the end of this document provides information about the documented features and lists the releases in which each feature is supported.

Use Cisco Feature Navigator to find information about platform support and Cisco software image support. To access Cisco Feature Navigator, go to <http://tools.cisco.com/ITDIT/CFN/>. An account on <http://www.cisco.com/> is not required.

### Contents

- [Hardware Compatibility Matrix for the Cisco cBR Series Routers, on page 535](#)
- [Prerequisites for Downgrading Channel Bonding in Battery Backup Mode, on page 537](#)
- [Restrictions for Downgrading Channel Bonding in Battery Backup Mode, on page 537](#)
- [Information About Downgrading Channel Bonding in Battery Backup Mode, on page 538](#)
- [How to Configure Downgrading Channel Bonding in Battery Backup Mode, on page 539](#)
- [Verifying the Configuration for Channel Bonding Downgrade in Battery Backup Mode, on page 541](#)
- [Additional References, on page 544](#)
- [Feature Information for Downgrading Channel Bonding in Battery Backup Mode, on page 545](#)

## Hardware Compatibility Matrix for the Cisco cBR Series Routers



---

**Note** The hardware components that are introduced in a given Cisco IOS-XE Release are supported in all subsequent releases unless otherwise specified.

---

Table 106: Hardware Compatibility Matrix for the Cisco cBR Series Routers

| Cisco CMTS Platform                    | Processor Engine                                                                                                                                                                                  | Interface Cards                                                                                                                                                                                                                                                                                                                                                                                                                                                                                                                                                                                                                                                                                                                                                                                 |
|----------------------------------------|---------------------------------------------------------------------------------------------------------------------------------------------------------------------------------------------------|-------------------------------------------------------------------------------------------------------------------------------------------------------------------------------------------------------------------------------------------------------------------------------------------------------------------------------------------------------------------------------------------------------------------------------------------------------------------------------------------------------------------------------------------------------------------------------------------------------------------------------------------------------------------------------------------------------------------------------------------------------------------------------------------------|
| Cisco cBR-8 Converged Broadband Router | <p><b>Cisco IOS-XE Release 16.5.1 and Later Releases</b></p> <p>Cisco cBR-8 Supervisor:</p> <ul style="list-style-type: none"> <li>• PID—CBR-SUP-250G</li> <li>• PID—CBR-CCAP-SUP-160G</li> </ul> | <p><b>Cisco IOS-XE Release 16.5.1 and Later Releases</b></p> <p>Cisco cBR-8 CCAP Line Cards:</p> <ul style="list-style-type: none"> <li>• PID—CBR-LC-8D30-16U30</li> <li>• PID—CBR-LC-8D31-16U30</li> <li>• PID—CBR-RF-PIC</li> <li>• PID—CBR-RF-PROT-PIC</li> <li>• PID—CBR-CCAP-LC-40G</li> <li>• PID—CBR-CCAP-LC-40G-R</li> <li>• PID—CBR-CCAP-LC-G2-R</li> <li>• PID—CBR-SUP-8X10G-PIC</li> <li>• PID—CBR-2X100G-PIC</li> </ul> <p>Digital PICs:</p> <ul style="list-style-type: none"> <li>• PID—CBR-DPIC-8X10G</li> <li>• PID—CBR-DPIC-2X100G</li> </ul> <p>Cisco cBR-8 Downstream PHY Module:</p> <ul style="list-style-type: none"> <li>• PID—CBR-D31-DS-MOD</li> </ul> <p>Cisco cBR-8 Upstream PHY Modules:</p> <ul style="list-style-type: none"> <li>• PID—CBR-D31-US-MOD</li> </ul> |



**Note** Do not use DPICs (8X10G and 2x100G) to forward IP traffic, as it may cause buffer exhaustion, leading to line card reload.

The only allowed traffic on a DPIC interface is DEPI, UEPI, and GCP traffic from the Cisco cBR-8 router to Remote PHY devices. Other traffic such as DHCP, SSH, and UTSC should flow via another router, since DPICs cannot be used for normal routing.

## Prerequisites for Downgrading Channel Bonding in Battery Backup Mode

- The cable modem must be DOCSIS3.0-compliant with battery backup capability.
- At least one free Downstream Resilient Bonding Group (RBG) must be available.



---

**Note** For information about how to reserve RBG and verify reserved RBG, refer to [Downstream Resiliency Bonding Group](#) , on page 361

---

## Restrictions for Downgrading Channel Bonding in Battery Backup Mode

- If the cable modem does not support the CM-STATUS events 9 and 10, channel bonding is not downgraded for the cable modem in battery backup mode.



---

**Note** We recommend that you configure separate dynamic bonding groups for each primary channel in a MAC domain.

---

- If the cable modem has an active voice call, channel bonding is not downgraded for the cable modem in battery backup mode.
- If the cable modem is working on the protect line card, channel bonding is not downgraded if its primary channel is not included in the dynamic bonding group.
- If the line card switches over when the cable modem is entering or exiting the battery backup mode, the cable modem may go offline.

# Information About Downgrading Channel Bonding in Battery Backup Mode

Table 107: Feature History

| Feature Name                                  | Release Information         | Feature Description                                                                                                                                                                                                                                                                                                                                                                                                                                                                                                                                                                                                                                        |
|-----------------------------------------------|-----------------------------|------------------------------------------------------------------------------------------------------------------------------------------------------------------------------------------------------------------------------------------------------------------------------------------------------------------------------------------------------------------------------------------------------------------------------------------------------------------------------------------------------------------------------------------------------------------------------------------------------------------------------------------------------------|
| Support for DOCSIS 3.1 Battery Reduction Mode | Cisco IOS XE Dublin 17.12.1 | <p>You can configure channel bonding downgrade for cable modems in battery backup mode by using the <b>cable reduction-mode mta-battery</b> command in global configuration and interface configuration mode.</p> <p>In this release, you can configure the <b>scqam-primary</b> keyword for the <b>cable reduction-mode mta-battery</b> command. Use the SCQAM primary channel in battery backup mode when the modem is with OFDM primary channel. This option is disabled by default.</p> <p><b>Note:</b> For DOCSIS 3.1 battery mode, the inter-op testing with real CM is limited due to CM limitation. Most of the testing was run by simulation.</p> |

When this feature is enabled and the cable modem enters the battery backup mode, channel bonding is downgraded to one downstream and one upstream channels (battery backup 1x1 mode). This feature reduces the power usage when the cable modem is running on battery backup. When the cable modem returns to the AC power mode, the channel bonding is returned to its original configuration. You can configure this feature globally and for each MAC domain.



**Note** We recommend that you enable this feature globally and for each MAC domain.

The cable modem uses the following CM-STATUS events to indicate its power status to the Cisco CMTS:

- 9—Indicates that the cable modem is operating in battery backup mode.
- 10—Indicates that the cable modem has returned to AC power mode.

When this feature is disabled, cable modem cannot downgrade the channel bonding even if it is running on battery backup.

# How to Configure Downgrading Channel Bonding in Battery Backup Mode

This section contains the following:

## Configuring Channel Bonding Downgrade in Battery Backup Mode Globally

### Procedure

|        | Command or Action                                                                                                                                                                               | Purpose                                                                                                                                                                                                                                                                                    |
|--------|-------------------------------------------------------------------------------------------------------------------------------------------------------------------------------------------------|--------------------------------------------------------------------------------------------------------------------------------------------------------------------------------------------------------------------------------------------------------------------------------------------|
| Step 1 | <b>enable</b><br><b>Example:</b><br>Router> <b>enable</b>                                                                                                                                       | Enables privileged EXEC mode.<br><ul style="list-style-type: none"><li>• Enter your password if prompted.</li></ul>                                                                                                                                                                        |
| Step 2 | <b>configure terminal</b><br><b>Example:</b><br>Router# <b>configure terminal</b>                                                                                                               | Enters global configuration mode.                                                                                                                                                                                                                                                          |
| Step 3 | <b>cable reduction-mode mta-battery enable</b><br><b>Example:</b><br>Router(config)# <b>cable reduction-mode mta-battery enable</b>                                                             | Enables the channel bonding downgrade for cable modems in battery backup mode.                                                                                                                                                                                                             |
| Step 4 | <b>cable reduction-mode mta-battery dampen-time seconds</b><br><b>Example:</b><br>Router(config)# <b>cable reduction-mode mta-battery dampen-time 40</b>                                        | (Optional) Configures the dampen time, in seconds, to defer the cable modems from entering or exiting the channel bonding downgrade 1x1 mode.                                                                                                                                              |
| Step 5 | <b>cable reduction-mode mta-battery ranging-init-technique us-ranging-init-technique</b><br><b>Example:</b><br>Router(config)# <b>cable reduction-mode mta-battery ranging-init-technique 3</b> | (Optional) Configures the init-ranging technique.                                                                                                                                                                                                                                          |
| Step 6 | <b>cable reduction-mode mta-battery dynamic-channel-percent percent</b><br><b>Example:</b><br>Router(config)# <b>cable reduction-mode mta-battery dynamic-channel-percent 10</b>                | (Optional) Configures the maximum and first try percentage of dynamic channel bandwidth in battery backup mode.<br><b>Note</b> Ensure to leave enough bandwidth for primary channel so that it can allocate dynamic channel bandwidth when it joins a newly created dynamic bonding group. |
| Step 7 | <b>exit</b><br><b>Example:</b><br>Router(config)# <b>exit</b>                                                                                                                                   | Returns to the privileged EXEC mode.                                                                                                                                                                                                                                                       |

## Configuring Channel Bonding Downgrade in Battery Backup Mode for MAC Domain

### Procedure

|               | Command or Action                                                                                                                                          | Purpose                                                                                                                           |
|---------------|------------------------------------------------------------------------------------------------------------------------------------------------------------|-----------------------------------------------------------------------------------------------------------------------------------|
| <b>Step 1</b> | <b>enable</b><br><b>Example:</b><br>Router> <b>enable</b>                                                                                                  | Enables privileged EXEC mode.<br><ul style="list-style-type: none"><li>• Enter your password if prompted.</li></ul>               |
| <b>Step 2</b> | <b>configure terminal</b><br><b>Example:</b><br>Router# <b>configure terminal</b>                                                                          | Enters global configuration mode.                                                                                                 |
| <b>Step 3</b> | <b>interface wideband-cable</b><br><i>slot/subslot/port:wideband-channel</i><br><b>Example:</b><br>Router(config)# <b>interface wideband-cable 1/0/0:7</b> | Configures a wideband cable interface.                                                                                            |
| <b>Step 4</b> | <b>cable ds-resiliency</b><br><b>Example:</b><br>Router(config-if)# <b>cable ds-resiliency</b>                                                             | Reserves a resiliency bonding group or WB interface for usage on a line card, on a per controller basis.                          |
| <b>Step 5</b> | <b>exit</b><br><b>Example:</b><br>Router(config-if)# <b>exit</b>                                                                                           | Returns to the global configuration mode.                                                                                         |
| <b>Step 6</b> | <b>interface cable</b> <i>slot/subslot/port</i><br><b>Example:</b><br>Router(config)# <b>interface cable 9/0/0</b>                                         | Specifies the cable interface on the router and enters the interface configuration mode.                                          |
| <b>Step 7</b> | <b>cable reduction-mode mta-battery enable</b><br><b>Example:</b><br>Router(config-if)# <b>cable reduction-mode mta-battery enable</b>                     | Enables the channel bonding downgrade for cable modems in battery backup mode for each MAC domain.                                |
| <b>Step 8</b> | <b>cable cm-status enable 9</b><br><b>Example:</b><br>Router(config-if)# <b>cable cm-status enable 9</b>                                                   | Enables the CM-STATUS event 9 for the MAC domain. The value 9 indicates that the cable modem is operating in battery backup mode. |
| <b>Step 9</b> | <b>cable cm-status enable 10</b><br><b>Example:</b><br>Router(config-if)# <b>cable cm-status enable 10</b>                                                 | Enables the CM-STATUS event 10 for the MAC domain. The value 10 indicates that the cable modem has returned to AC power mode.     |



|         | Command or Action                                                  | Purpose                              |
|---------|--------------------------------------------------------------------|--------------------------------------|
| Step 10 | <b>end</b><br><br><b>Example:</b><br>Router(config-if)# <b>end</b> | Returns to the privileged EXEC mode. |

## Verifying the Configuration for Channel Bonding Downgrade in Battery Backup Mode

- **show cable modem**—Displays information if the cable modem is running in battery backup mode.

Following is a sample output of the command:

```
Router# show cable modem

D
MAC Address      IP Address      I/F           MAC           Prim  RxPwr  Timing Num
I
P
f45f.d4a1.b75a ---          C6/1/0/UB    p-online (pt)  846  !-3.50  1475  0
N
c427.9551.3489 30.154.1.12    C6/1/0/UB    w-online (pt)  930  -0.50  1579  2
Y
f45f.d4a1.b762 30.55.223.253  C6/1/0/UB    w-online       1770  0.00   1503  0
Y
0016.925e.661a 30.55.230.136  C6/1/0/U0    online (pt)    825  -0.50  1467  1
N
4458.2945.458a 30.0.7.72     C6/1/0/UB    w-online       3916  0.00   1511  2
Y
4458.2945.401e ---          C6/1/0/UB    w-online (pt)  847  -0.50  1473  1
N
4458.2945.20c6 ---          C6/1/0/UB    w-online (pt) (bm) 895  0.00   1481  0
N
```

- **show cable modem reduction-mode mta-battery**—Displays the channel bonding downgrade information for cable modems in battery backup mode.

Following is a sample output of the command:

```
Router# show cable modem reduction-mode mta-battery

I/F           MAC Address      ID      Orig BG      RFs      ID      Curr BG      Upstream
-----
C7/0/0       0025.2eaf.843e  897     Wi7/0/0:0    4         252     Wi7/0/0:1    US0
C7/0/0       0025.2eaf.8356  897     Wi7/0/0:0    4         252     Wi7/0/0:1    US0
C7/0/0       0015.d176.5199  897     Wi7/0/0:0    4         252     Wi7/0/0:1    US0
```

Following is a sample output of the command for a cable modem when the MAC address is specified:

```
Router# show cable modem 0025.2eaf.843e reduction-mode mta-battery

I/F           MAC Address      ID      Orig BG      RFs      ID      Curr BG      Upstream
-----
C7/0/0       0025.2eaf.843e  897     Wi7/0/0:0    4         252     Wi7/0/0:1    US0
```

```
C7/0/0 0025.2eaf.843e 897 Wi7/0/0:0 4 252 Wi7/0/0:1 US0
```

Following is a sample output of the command for a cable modem when the IP address is specified:

```
Router# show cable modem 90.18.0.9 reduction-mode mta-battery
```

| I/F    | MAC Address    | ID  | Orig BG<br>I/F | RFs | ID  | Curr BG<br>I/F | Upstream |
|--------|----------------|-----|----------------|-----|-----|----------------|----------|
| C7/0/0 | 0025.2eaf.843e | 897 | Wi7/0/0:0      | 4   | 252 | Wi7/0/0:1      | US0      |

Following is a sample output of the command for a cable modem when the IPv6 address is specified:

```
Router# show cable modem 2001:18::9 reduction-mode mta-battery
```

| I/F    | MAC Address    | ID  | Orig BG<br>I/F | RFs | ID  | Curr BG<br>I/F | Upstream |
|--------|----------------|-----|----------------|-----|-----|----------------|----------|
| C7/0/0 | 0025.2eaf.843e | 897 | Wi7/0/0:0      | 4   | 252 | Wi7/0/0:1      | US0      |

- **show cable modem verbose**—Displays the detailed information for the cable modem.

Following is a sample output of the command:

```
Router# show cable modem 54d4.6ffb.30fd verbose
```

```
MAC Address           : 54d4.6ffb.30fd
IP Address            : 40.4.58.14
IPv6 Address         : 2001:40:4:58:741A:408D:7E4B:D7C8
Dual IP              : Y
Prim Sid             : 9
Host Interface       : C7/0/0/UB
MD-DS-SG / MD-US-SG : 1 / 1
MD-CM-SG            : 0x3C0101
Primary Wideband Channel ID : 897 (Wi7/0/0:0)
Primary Downstream   : In7/0/0:2 (RfId : 722)
Wideband Capable    : Y
RCP Index           : 3
RCP ID              : 00 10 00 00 08
Downstream Channel DCID RF Channel : 99 7/0/0:2
Downstream Channel DCID RF Channel : 97 7/0/0:0
Downstream Channel DCID RF Channel : 98 7/0/0:1
Downstream Channel DCID RF Channel : 100 7/0/0:3
Multi-Transmit Channel Mode : Y
Extended Upstream Transmit Power : 0dB
Upstream Channel     : US0 US1
Ranging Status       : sta sta
Upstream SNR (dB)    : 36.12 32.55
Upstream Data SNR (dB) : -- --
Received Power (dBmV) : 0.00 0.00
Reported Transmit Power (dBmV) : 25.25 26.00
Peak Transmit Power (dBmV) : 54.00 54.00
Phy Max Power (dBmV) : 54.00 54.00
Minimum Transmit Power (dBmV) : 24.00 24.00
Timing Offset (97.6 ns) : 1226 1226
Initial Timing Offset : 1229 973
Rng Timing Adj Moving Avg(0.381 ns) : -1 0
Rng Timing Adj Lt Moving Avg : -7 0
Rng Timing Adj Minimum : -768 0
Rng Timing Adj Maximum : 0 64768
Pre-EQ Good          : 0 0
Pre-EQ Scaled        : 0 0
Pre-EQ Impulse       : 0 0
```

```

Pre-EQ Direct Loads           : 0          0
Good Codewords rx            : 515        472
Corrected Codewords rx       : 0          0
Uncorrectable Codewords rx   : 0          0
Phy Operating Mode           : atdma*    atdma*
sysDescr                      :
Downstream Power              : 0.00 dBmV (SNR = ----- dB)
MAC Version                   : DOC3.0
QoS Provisioned Mode         : DOC1.1
Enable DOCSIS2.0 Mode        : Y
Modem Status                  : {Modem= w-online, Security=disabled}
Capabilities                  : {Frag=N, Concat=N, PHS=Y}
Security Capabilities         : {Priv=, EAE=Y, Key_len=}
L2VPN Capabilities           : {L2VPN=N, eSAFE=N}
Sid/Said Limit                : {Max US Sids=16, Max DS Sids=15}
Optional Filtering Support    : {802.1P=N, 802.1Q=N, DUT=N}
Transmit Equalizer Support    : {Taps/Symbol= 1, Num of Taps= 24}
Number of CPE IPs            : 0(Max CPE IPs = 16)
CFG Max-CPE                  : 200
Flaps                         : 0()
Errors                        : 0 CRCs, 0 HCSes
Stn Mtn Failures             : 0 aborts, 0 exhausted
Total US Flows                : 1(1 active)
Total DS Flows                : 1(1 active)
Total US Data                 : 7 packets, 2006 bytes
Total US Throughput           : 0 bits/sec, 0 packets/sec
Total DS Data                 : 5 packets, 1202 bytes
Total DS Throughput           : 0 bits/sec, 0 packets/sec
LB group ID assigned (index)  : 2151416065 (48131)
LB group ID in config file (index) : N/A (N/A)
LB policy ID                  : 0
LB policy ID in config file   : 0
LB priority                   : 0
Tag                           :
Required DS Attribute Mask    : 0x0
Forbidden DS Attribute Mask   : 0x0
Required US Attribute Mask    : 0x0
Forbidden US Attribute Mask   : 0x0
Service Type ID               :
Service Type ID in config file :
Active Classifiers            : 2 (Max = NO LIMIT)
CM Upstream Filter Group      : 0
CM Downstream Filter Group    : 0
CPE Upstream Filter Group     : 0
CPE Downstream Filter Group   : 0
DSA/DSX messages             : permit all
Voice Enabled                  : NO
CM Energy Management Capable  : Y
CM Enable Energy Management   : Y
CM Enter Energy Management    : No
Battery Mode                  : Yes
Battery Mode Status          : BATTERY_MODE / AC_POWER_MODE
DS Change Times               : 0
Boolean Services              : 2
Number of Multicast DSIDs Support : 16
MDF Capability Mode           : 2
IGMP/MLD Version              : MLDv2
FCType10 Forwarding Support  : Y
Features Bitmask              : 0x0
Total Time Online              : 2h12m (2h12m since last counter reset)
CM Initialization Reason      : NO_PRIM_SF_USCHAN
CFG Max IPv6 CPE Prefix       : 16 (-1 used)

```



**Note** *Battery Mode* indicates if the cable modem is in battery backup mode or AC power mode.

*Battery Mode Status* indicates the status of the cable modem:

- When the cable modem is in AC\_POWER\_MODE/BATTERY\_MODE status, it is in stable state.
- When the cable modem is in AC\_POWER\_PENDING/BATTERY\_PENDING status, it is in transfer state.
- When the cable modem is in AC\_POWER\_HOLD/BATTERY\_HOLD status, it is updating status of the last event received until the dampen time expires.

- **show cable modem cm-status**—Displays the cable modem CM-STATUS event information.

Following is a sample output of the command:

```
Router# show cable modem e448.c70c.9d80 cm-status
```

| I/F       | MAC Address    | Event          | TID | Count | Error | Dups | Time           |
|-----------|----------------|----------------|-----|-------|-------|------|----------------|
| C6/0/3/UB | e448.c70c.9d80 | Battery backup | 14  | 1     | 0     | 0    | Apr 2 22:17:29 |
|           | e448.c70c.9d80 | A/C power      | 1   | 1     | 0     | 0    | Apr 2 22:43:52 |

## Additional References

### Related Documents

| Related Topic | Document Title                                     |
|---------------|----------------------------------------------------|
| CMTS commands | <a href="#">Cisco CMTS Cable Command Reference</a> |

### Standards and RFCs

| Standard/RFC                | Title                                                                                                               |
|-----------------------------|---------------------------------------------------------------------------------------------------------------------|
| CM-SP- MULPIv3.1-I01-131029 | Data-Over-Cable Service Interface Specifications, DOCSIS 3.1, MAC and Upper Layer Protocols Interface Specification |

**Technical Assistance**

| Description                                                                                                                                                                                                                                                                                                                                                                                                                                                                                                                                                             | Link                                                                    |
|-------------------------------------------------------------------------------------------------------------------------------------------------------------------------------------------------------------------------------------------------------------------------------------------------------------------------------------------------------------------------------------------------------------------------------------------------------------------------------------------------------------------------------------------------------------------------|-------------------------------------------------------------------------|
| <p>The Cisco Support website provides extensive online resources, including documentation and tools for troubleshooting and resolving technical issues with Cisco products and technologies.</p> <p>To receive security and technical information about your products, you can subscribe to various services, such as the Product Alert Tool (accessed from Field Notices), the Cisco Technical Services Newsletter, and Really Simple Syndication (RSS) Feeds.</p> <p>Access to most tools on the Cisco Support website requires a Cisco.com user ID and password.</p> | <a href="http://www.cisco.com/support">http://www.cisco.com/support</a> |

## Feature Information for Downgrading Channel Bonding in Battery Backup Mode

Use Cisco Feature Navigator to find information about the platform support and software image support. Cisco Feature Navigator enables you to determine which software images support a specific software release, feature set, or platform. To access Cisco Feature Navigator, go to the <https://cfng.cisco.com/> link. An account on the Cisco.com page is not required.



**Note** The following table lists the software release in which a given feature is introduced. Unless noted otherwise, subsequent releases of that software release train also support that feature.

**Table 108: Feature Information for Downgrading Channel Bonding in Battery Backup Mode**

| Feature Name            | Releases                    | Feature Information                                                                                                 |
|-------------------------|-----------------------------|---------------------------------------------------------------------------------------------------------------------|
| Battery Backup 1x1 Mode | Cisco IOS XE Everest 16.6.1 | This feature was introduced in the Cisco IOS XE Everest 16.6.1 on the Cisco cBR Series Converged Broadband Routers. |





## CHAPTER 30

# Upstream Bonding Support for D-PON

---

The DOCSIS Passive Optical Network (D-PON) architecture, also known as RF over Glass (RFoG), helps the cable operators enter fiber-to-home market space and utilize the DOCSIS infrastructure effectively.

- [Hardware Compatibility Matrix for the Cisco cBR Series Routers, on page 547](#)
- [Prerequisites for Upstream Bonding Support for D-PON, on page 548](#)
- [Restrictions for Upstream Bonding Support for D-PON, on page 549](#)
- [Information About Upstream Bonding Support for D-PON, on page 550](#)
- [How to Configure Upstream Bonding Support for D-PON , on page 551](#)
- [Verifying the Upstream Bonding Support for D-PON, on page 552](#)
- [Additional References, on page 552](#)
- [Feature Information for Upstream Bonding Support for D-PON, on page 553](#)

## Hardware Compatibility Matrix for the Cisco cBR Series Routers



---

**Note** The hardware components that are introduced in a given Cisco IOS-XE Release are supported in all subsequent releases unless otherwise specified.

---

Table 109: Hardware Compatibility Matrix for the Cisco cBR Series Routers

| Cisco CMTS Platform                    | Processor Engine                                                                                                                                                                       | Interface Cards                                                                                                                                                                                                                                                                                                                                                                                                                                                                                                                                                                                                                                                                                                                                                 |
|----------------------------------------|----------------------------------------------------------------------------------------------------------------------------------------------------------------------------------------|-----------------------------------------------------------------------------------------------------------------------------------------------------------------------------------------------------------------------------------------------------------------------------------------------------------------------------------------------------------------------------------------------------------------------------------------------------------------------------------------------------------------------------------------------------------------------------------------------------------------------------------------------------------------------------------------------------------------------------------------------------------------|
| Cisco cBR-8 Converged Broadband Router | <b>Cisco IOS-XE Release 16.5.1 and Later Releases</b><br>Cisco cBR-8 Supervisor: <ul style="list-style-type: none"> <li>• PID—CBR-SUP-250G</li> <li>• PID—CBR-CCAP-SUP-160G</li> </ul> | <b>Cisco IOS-XE Release 16.5.1 and Later Releases</b><br>Cisco cBR-8 CCAP Line Cards: <ul style="list-style-type: none"> <li>• PID—CBR-LC-8D30-16U30</li> <li>• PID—CBR-LC-8D31-16U30</li> <li>• PID—CBR-RF-PIC</li> <li>• PID—CBR-RF-PROT-PIC</li> <li>• PID—CBR-CCAP-LC-40G</li> <li>• PID—CBR-CCAP-LC-40G-R</li> <li>• PID—CBR-CCAP-LC-G2-R</li> <li>• PID—CBR-SUP-8X10G-PIC</li> <li>• PID—CBR-2X100G-PIC</li> </ul> Digital PICs: <ul style="list-style-type: none"> <li>• PID—CBR-DPIC-8X10G</li> <li>• PID—CBR-DPIC-2X100G</li> </ul> Cisco cBR-8 Downstream PHY Module: <ul style="list-style-type: none"> <li>• PID—CBR-D31-DS-MOD</li> </ul> Cisco cBR-8 Upstream PHY Modules: <ul style="list-style-type: none"> <li>• PID—CBR-D31-US-MOD</li> </ul> |



**Note** Do not use DPICs (8X10G and 2x100G) to forward IP traffic, as it may cause buffer exhaustion, leading to line card reload.

The only allowed traffic on a DPIC interface is DEPI, UEPI, and GCP traffic from the Cisco cBR-8 router to Remote PHY devices. Other traffic such as DHCP, SSH, and UTSC should flow via another router, since DPICs cannot be used for normal routing.

## Prerequisites for Upstream Bonding Support for D-PON

- DOCSIS 3.0 cable modems (CMs)



- DOCSIS 2.0 capable set-top boxes (STBs)
- You should configure the **cable upstream ranging-init-technique 2** command to prevent the use of additional broadcast initial ranging opportunities for the non D-PON reference upstream channels.

## Restrictions for Upstream Bonding Support for D-PON

- Multiple CMs cannot work at the same time. Each CM must get a separate time slot for upstream data transmission. Configuring D-PON ensures that the upstream scheduler allows only a single CM to transmit at a particular time.
- Cisco cBR-8 does not support Upstream Bonding for D-PON on Remote-PHY.
- It is possible to enable or disable D-PON for individual Mac domain.
- When you enable D-PON on a MAC domain, you must manually shut down and enable the MAC domain using **shutdown** and **no shutdown** command.
- When enabling D-PON on a MAC domain, the D-PON is not supported with upstream balance-scheduling. Remove the upstream balance scheduling using the following command:  

```
no cable upstream balance-scheduling
```
- All frequencies in a MAC domain must have the same configuration for:
  - minislot size
  - channel-width
  - modulation profile
- Supports only ATDMA DOCSIS mode.
- The following features are not supported in MAC domains configured for D-PON:
  - Load balancing
  - Spectrum management
  - Upstream configuration (to change upstream configuration, you should shut down the MAC domain)
  - S-CDMA logical channels
  - Lower modulations profiles (D-PON uses only 16 QAM and 64 QAM modulation profiles)
  - Channel-width other than 3.2 MHz and 6.4 MHz
  - In-service Software Upgrade (ISSU)
  - Mixing of D-PON and HFC on the same MAC domain
  - Software licensing

# Information About Upstream Bonding Support for D-PON

D-PON is a type of networking that allows the CMTS to transmit RF signals over the optical network. This technology enables the cable operators to use the RF technologies in a Hybrid Fiber-Coaxial (HFC) network.

The downstream data from the CMTS is combined with other RF signals at the hub and is sent to the transmitter. The signal from the transmitter is intended for multiple PONs. Each PON serves 32 homes from a single fiber.

The upstream data from the Optical Network Terminal (ONT) is combined at the splitter and sent to the hub, which is then routed to the optical receiver (RX). Upstream data from multiple optical receivers are combined and sent to the CMTS.

The upstream data to the CMTS contains signals from multiple PONs. Each upstream optical receiver is dedicated to a PON that can have multiple DOCSIS upstream sources (multiple modems and DSG terminals).

A PON can be configured in different ways, depending on the coaxial network. These configurations broadly fall under the following categories:

- **Internal Control Configuration**—In this configuration, the internal CM of the ONT controls the laser. Upstream signals go to the Ethernet interface of the CM allowing the ONT to control upstream timing. The device that uses this type of configuration is the Digital Audio Visual Council (DAVIC) set top terminal (STT).
- **External Control Configuration**—In this configuration, the presence of the RF at the ONT upstream input activates the laser. The device that uses this type of configuration is the DOCSIS Set-top Gateway (DSG) device.
- **Dual Control Configuration**—In this configuration, the home that contains an ONT with an internal CM and other DOCSIS upstream sources, like DSG devices. The RF presence detector or the internal CM control line detects the upstream signal and activates the upstream laser.

## D-PON on Upstream Scheduling

In D-PON implementation, the native upstream scheduling software of the CMTS controls the timing of the upstream data transmission. Only one PON Receiver Domain (PRD) is allowed to transmit upstream data at any given point of time, irrespective of the upstream frequency allocation. The reason for this is that two lasers from the ONT of a PRD cannot work simultaneously as it leads to an Optical Beat Interference (OBI). Moreover, the use of a frequency modulation (FM) for an upstream signal transmission results in PHY errors when multiple ONTs within a PON transmit simultaneously.

Initial maintenance regions are scheduled on all upstream channels to prevent the DOCSIS 3.0 CMs in a D-PON environment from failing initial ranging on any upstream channel. When a ranging request is received within a MAC domain configured for D-PON, the CM receives an upstream channel override to the D-PON reference channel (US0).

In this implementation of D-PON, a DOCSIS device within a PRD is given a timeslot to transmit the upstream data, irrespective of the upstream frequency. Therefore, there is no benefit in having more than one upstream in a MAC domain without using the upstream channel bonding feature.

The D-PON feature supports the following service types:

- Best effort (BE) 3.0 using up to four frequencies concurrently
- BE 2.0 using only a single frequency
- Unsolicited grant service (UGS) using only a single frequency

- Real-time polling service (RTPS) using only a single frequency
- Non-real-time polling service (nRTPS) using only a single frequency

## How to Configure Upstream Bonding Support for D-PON

This section describes how to enable D-PON for a MAC domain on the Cisco cBR router. The bonding group must include a reference channel which is default to the upstream channel 0.



**Note** The USCB can support a maximum of 4 US channels in a RFOG MAC domain in the following combination:

- US0
- US0, US1
- US0, US1, US2
- US0, US1, US2, US3

All US channels must be configured to have the same number of minislots, channel width (only 3.2 and 6.4 MHz supported), DOCSIS mode (only ATDMA supported) and modulation profile.

When enabling DPON on a MAC Domain, remove the command "cable upstream balance-scheduling?" as DPON is not supported with upstream balance-scheduling.

### Procedure

|        | Command or Action                                                                                                            | Purpose                                                                |
|--------|------------------------------------------------------------------------------------------------------------------------------|------------------------------------------------------------------------|
| Step 1 | <b>enable</b><br><b>Example:</b><br>Router> <b>enable</b>                                                                    | Enables privileged EXEC mode. Enter your password if prompted.         |
| Step 2 | <b>configure terminal</b><br><b>Example:</b><br>Router# <b>configure terminal</b>                                            | Enters global configuration mode.                                      |
| Step 3 | <b>interface cable slot/subslot/cable-interface-index</b><br><b>Example:</b><br>Router(config)# <b>interface cable 8/0/0</b> | Enters interface configuration mode for the specified cable interface. |
| Step 4 | <b>cable upstream dpon</b><br><b>Example:</b><br>Router(config-if)# <b>cable upstream dpon</b>                               | Enables D-PON for a MAC domain.                                        |
| Step 5 | <b>shutdown</b><br><b>Example:</b><br>Router(config-if)# <b>shutdown</b>                                                     | Shuts down the interface.                                              |

|        | Command or Action                                                              | Purpose                                                                     |
|--------|--------------------------------------------------------------------------------|-----------------------------------------------------------------------------|
| Step 6 | <b>no shutdown</b><br><b>Example:</b><br>Router(config-if)# <b>no shutdown</b> | Enables the interface.                                                      |
| Step 7 | <b>end</b><br><b>Example:</b><br>Router(config-if)# <b>end</b>                 | Exits interface configuration mode and returns to the privileged EXEC mode. |

## Verifying the Upstream Bonding Support for D-PON

To verify the upstream scheduler output for a MAC domain configured with D-PON, use the **show interface cable mac-scheduler** command.



**Note** The D-PON reference channel US0 (US channel-id 1) MAP serves as a template for producing other MAPs within the MAC domain. Therefore, some of the statistics related to upstream scheduling is not relevant for other channels, except for the D-PON reference channel.

```
Router# show interface cable 8/0/0 mac-scheduler 1
DOCSIS 1.1 MAC scheduler for Cable8/0/0/U1 : rate 30720000
wfg:None
us_balance:OFF
dpon_mode:ON
fairness:OFF
Queue[Rng Polls] flows 0
Queue[CIR Grants] flows 0
Queue[BE(07) Grants] flows 0
Queue[BE(06) Grants] flows 0
Queue[BE(05) Grants] flows 0
Queue[BE(04) Grants] flows 0
Queue[BE(03) Grants] flows 0
Queue[BE(02) Grants] flows 0
Queue[BE(01) Grants] flows 0
Queue[BE(00) Grants] flows 0
Req Slots 1824595508, Req/Data Slots 10640906
Init Mtn Slots 89924653, Stn Mtn Slots 989543
Short Grant Slots 0, Long Grant Slots 0
Adv Phy Short Grant Slots 538, Adv Phy Long Grant Slots 219831
Adv Phy UGS Grant Slots 0
Avg upstream channel utilization : 0%
Avg percent contention slots : 98%
Avg percent initial ranging slots : 1%
Avg percent minislots lost on late MAPs : 0%
MAP TSS: lch_state 9, init_retries 0
late_initial_maps 0, late_ucd_maps 0
mac-phy tss errors 0, missed ccc 0
```

## Additional References

The following sections provide references related to the Upstream Bonding Support for D-PON feature.

**Related Documents**

| Related Topic | Document Title                     |
|---------------|------------------------------------|
| Prisma D-PON  | <a href="#">Cisco Prisma D-PON</a> |

**Technical Assistance**

| Description                                                                                                                                                                                                                                                                                                                                                                                                                                                                                                                                                             | Link                                                                    |
|-------------------------------------------------------------------------------------------------------------------------------------------------------------------------------------------------------------------------------------------------------------------------------------------------------------------------------------------------------------------------------------------------------------------------------------------------------------------------------------------------------------------------------------------------------------------------|-------------------------------------------------------------------------|
| <p>The Cisco Support website provides extensive online resources, including documentation and tools for troubleshooting and resolving technical issues with Cisco products and technologies.</p> <p>To receive security and technical information about your products, you can subscribe to various services, such as the Product Alert Tool (accessed from Field Notices), the Cisco Technical Services Newsletter, and Really Simple Syndication (RSS) Feeds.</p> <p>Access to most tools on the Cisco Support website requires a Cisco.com user ID and password.</p> | <a href="http://www.cisco.com/support">http://www.cisco.com/support</a> |

## Feature Information for Upstream Bonding Support for D-PON

Use Cisco Feature Navigator to find information about the platform support and software image support. Cisco Feature Navigator enables you to determine which software images support a specific software release, feature set, or platform. To access Cisco Feature Navigator, go to the <https://cfmg.cisco.com/> link. An account on the Cisco.com page is not required.



**Note** The following table lists the software release in which a given feature is introduced. Unless noted otherwise, subsequent releases of that software release train also support that feature.

**Table 110: Feature Information for Upstream Bonding Support for D-PON**

| Feature Name                       | Releases                 | Feature Information                                                              |
|------------------------------------|--------------------------|----------------------------------------------------------------------------------|
| Upstream Bonding Support for D-PON | Cisco IOS XE Fuji 16.7.1 | This feature was integrated on the Cisco cBR Series Converged Broadband Routers. |





# CHAPTER 31

## Energy Management Mode

Data-over-Cable Service Interface Specifications (DOCSIS) cable modems (CM) and CMTS support a low power energy mode referred to as the Energy Management 1x1 (EM) mode. During idle times, when the data rate demand of a user is met by the available capacity on a single upstream and downstream channel pair to which it is assigned, the CM switches to the Energy Management 1x1 mode. When the CM requires a higher data rate than that can be reliably provided on the single channel pair, the CMTS instructs the CM to return to the larger transmit and receive channel set.

### Contents

- [Information About Energy Management Mode, on page 555](#)
- [Prerequisites for Energy Management Mode, on page 559](#)
- [Restrictions for the Energy Management Mode, on page 559](#)
- [How to Configure the Energy Management Mode, on page 562](#)
- [Verifying the Energy Management Mode, on page 563](#)
- [Feature Information for Energy Management Mode, on page 566](#)

## Information About Energy Management Mode

The following sections provide more information about the Energy Management mode.



---

**Note** DOCSIS 3.1 CM's do not support the Energy Management mode in cBR-8 routers.

---

## Dynamic Downstream Bonding Group

To support the Energy Management 1x1 (EM) mode feature, CMTS selects an upstream and a downstream channel pair for CM. The downstream and upstream channel assigned to the CMs should be available. If CMTS selects a channel that is not available, the downstream bonding channel might fail.

To simplify the process, CMTS chooses the 1x1 bonding group for the CM according to the following rules:

- For upstream, it chooses the highest actual available bandwidth channel from the upstream channels currently used by the CM.
- For downstream, CMTS chooses the current primary downstream channel used by the CM.

- If the CM is online with channel bonding 1xN or Nx1, and requests to enter into the EM mode, CMTS does not change the upstream and the downstream channel if the original channel bonding is 1 and the Quality of Service (QoS) parameter is not updated.
- CMTS checks the existing dynamic bonding groups (DBG), for an exact match in the target channel.
  - If found, CMTS uses this bonding group to instruct the CM to enter into EM mode.
  - If there is no available DBG and there is an unused DBG, CMTS adds the primary channel into the unused DBG and instructs the CM to enter the EM mode.
  - If there is no available DBG and no unused DBG, CMTS logs a warning to notify you that a new DGB should be configured.

## Flow Chart of the CM Power State

The following figure shows the flow chart of the CM power state:



Figure 22: Flow Chart for the Power State of the Cable Modem

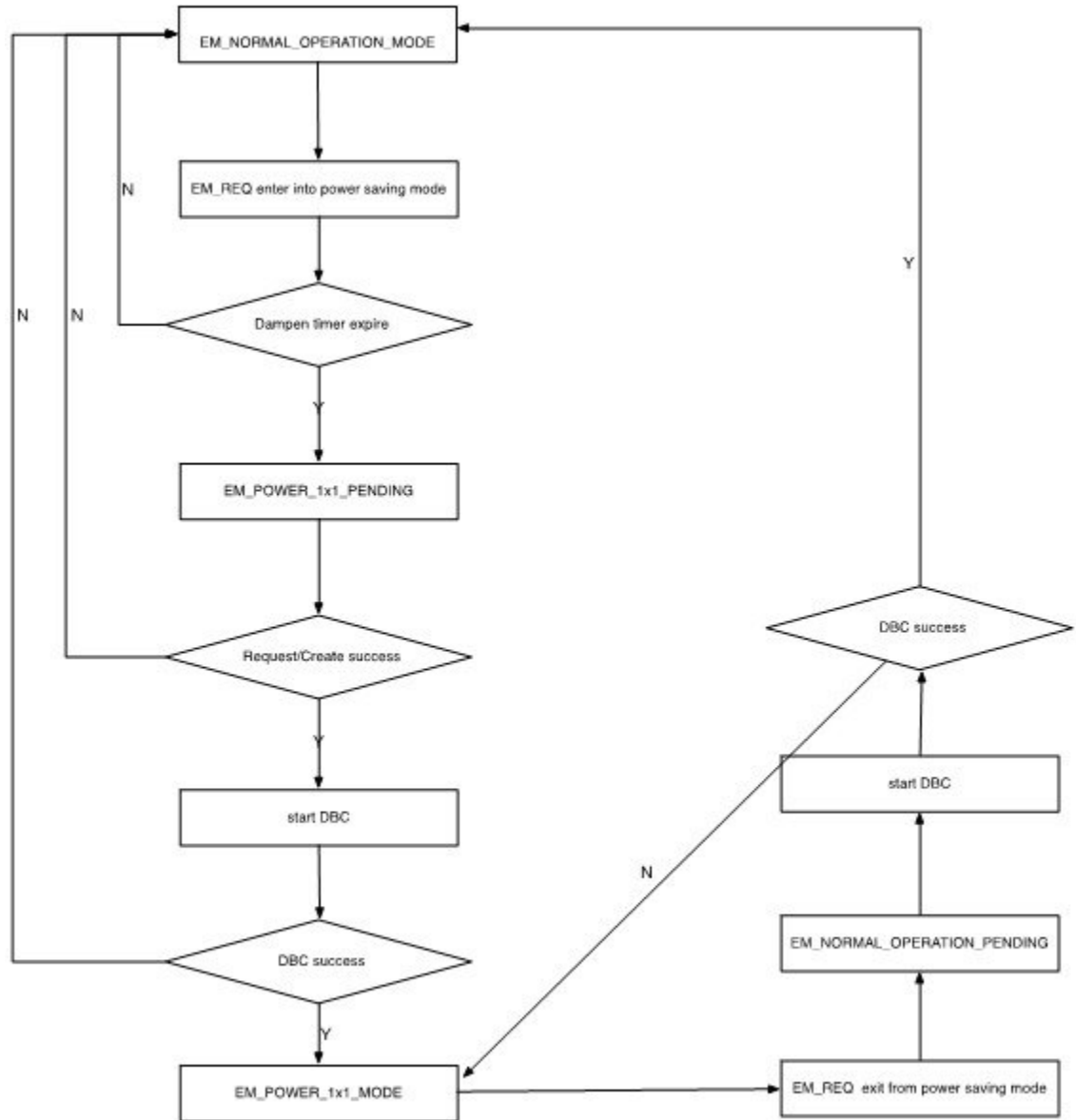

## Interaction with the Battery Mode

Energy management mode is similar to battery mode as they both enter the 1x1 mode to save power. But, both have a different purpose to enter the 1x1 mode, so there are some differences in their behavior. The purpose of EM mode is to save power when the traffic is low, and it has minimum impact on the normal service. The purpose of the battery mode is try to guarantee the voice service, especially the 911 call service, for which it may drop other services, if necessary.

The table below describes the behavior difference between energy management mode and battery mode.

|           | Energy Management (EM) Mode                                                                                                                                                                                                                                                                                                                                                       | Battery Mode (BM)                                                                                                                                                                                                                                               |
|-----------|-----------------------------------------------------------------------------------------------------------------------------------------------------------------------------------------------------------------------------------------------------------------------------------------------------------------------------------------------------------------------------------|-----------------------------------------------------------------------------------------------------------------------------------------------------------------------------------------------------------------------------------------------------------------|
| QoS       | Minimum reserved rate service up to 200k.                                                                                                                                                                                                                                                                                                                                         | No minimum reserved rate.                                                                                                                                                                                                                                       |
| Multicast | <ul style="list-style-type: none"> <li>• IGMP request is guaranteed.</li> <li>• If the CM has joined the Internet Group Management Protocol (IGMP) groups, CMTS rejects the EM request to enter the EM mode and keeps the CM in the IGMP groups.</li> <li>• If the CM is in the EM mode and IGMP join request is received, CMTS instructs the CM to leave the EM mode.</li> </ul> | <ul style="list-style-type: none"> <li>• If the CM has joined IGMP groups and CMTS receives a CM-STATUS event with code 9, CMTS lets the CM leave the IGMP group.</li> <li>• If the CM is in the BM, CMTS rejects the IGMP join request from the CM.</li> </ul> |

BM has higher priority than the EM mode. If a CM is already in EM mode and a power off occurs, CM enters into the BM. After the power is restored, the CM returns to the normal mode, and if the traffic is lower than the threshold, it re-enters the EM mode. The CM does not directly transfer from the BM to the EM mode.

The interaction between the battery mode and the energy management mode is illustrated in the figure below:

**Figure 23: Interaction Between the BM and the EM Modes**

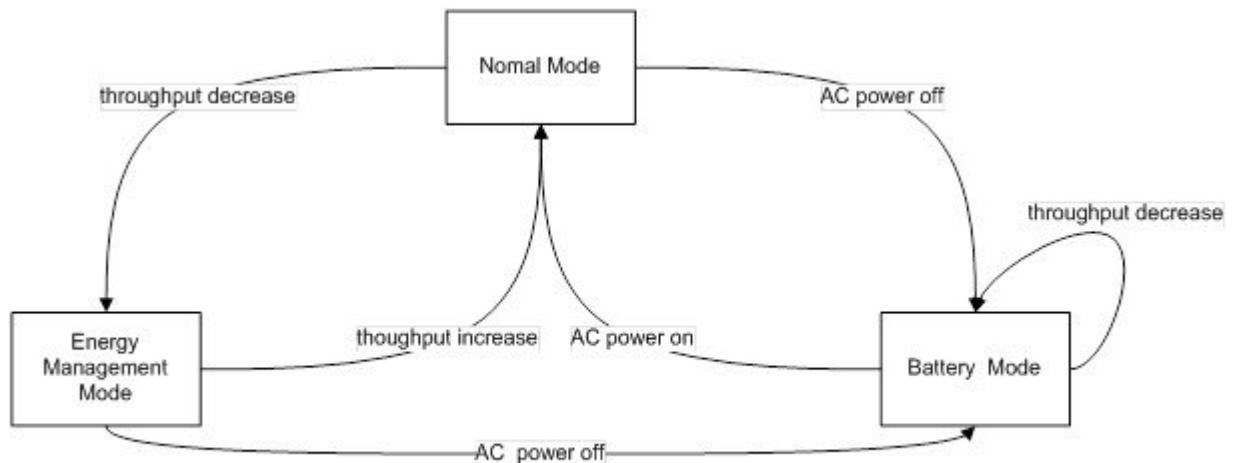

1. When the CM is in normal mode and CMTS receives a request to enter the EM mode, CMTS instructs the CM to enter the EM mode with downstream bonding channel (DBC).
2. When the CM is in EM mode and CMTS receives a request to leave the EM mode, CMTS instructs the CM to leave the EM mode to normal mode with DBC.
3. When the CM is in normal mode and CMTS receives a message: CM operating on battery backup, CMTS instructs the CM to enter the BM mode with DBC.
4. When the CM is in BM mode and CMTS receives a message: CM operating on AC power, CMTS instructs the CM to leave the BM mode to normal mode with DBC.

5. When the CM is in EM mode and CMTS receives a message: CM operating on battery backup, CMTS instructs the CM to enter the BM mode with service flow re-admin.
6. When the CM is in BM mode and CMTS receives a request to enter EM mode, CMTS waits until it receives the message: CM operating on AC power. It then instructs the CM to return to normal mode.

## Handling Energy Management Request Load

When many CMs send EM requests at the same time, such as at the beginning or end of work hours, the traffic soars or slumps in a very short period and causes heavy load for CMTS. A throttle mechanism is adopted to avoid such load surge for CMTS.

The line card EM process defines a variable that indicates the current transactions handled by the process. When an energy management request is received and the maximum number of transactions is not met, CMTS handles this request and updates the counter of current transactions. When the maximum number of transactions is met, CMTS sends a temporary reject response. After a transaction is over or a CM goes offline, the counter of current transactions is updated.

## Supervisor High Availability and Line Card Switchover

Energy Management feature supports supervisor high availability and line card switchover with limitations.

The active supervisor or line card syncs the EM mode data of a CM to the standby SUP or protected line card when the CM enters a stable EM status. When a CM enters or leaves the EM mode with an ongoing DBC process, the supervisor high availability or line card switchover causes the CM to enter into an offline or online status.

## Prerequisites for Energy Management Mode

To enable the energy management mode, you must configure resiliency bonding group (RBG) and dynamic bonding group.

## Restrictions for the Energy Management Mode

### Restrictions for CMTS High Availability

- If there is no DBG available, CMTS cannot create a new DBG on the protected line card and CMs cannot enter the EM mode.
- Line card switchover is not supported when the CM enters the EM mode from the normal mode or exits the EM mode to the normal mode.
- To reduce the operation of the EM mode, the information about the EM status is not synced with the protected line card. Hence, the EM status is cleared after the line card high availability.

## Restrictions for Dynamic Bonding Group

To support the EM feature, CMTS configures separate DBG for each primary channel in each MAC domain. For example, if a MAC domain has eight primary channels, it will create eight DBGs for the MAC domain. This ensures that the EM does not fail due to lack of DBGs.

## Restrictions for Interaction of CMTS with Other Features

The following sections describe the restrictions for CMTS interaction with other features.

### Voice

If a voice call is in progress, CMTS does not instruct the CM to enter into the EM mode.

When the CM is in the EM mode, and it receives a voice call, it adds a dynamic Unsolicited Grant Service (UGS) or Unsolicited Grant Service with activity detection (UGS-AD) service flow. During the voice call, the CM does not exit from the EM mode irrespective of the flow of traffic. Voice service is given the highest priority

### Dynamic Bonding Change and Dynamic Channel Change and Related Applications

In D2.0 and D3.0 load-balance (static and dynamic), CM is not moved by load-balance when it is in EM mode.

For RF-adapt, CM is not relocated to an alternate logical channel by the RF-adapt when it is in EM mode.

### Multicast

- When the CM is in a multicast group, CMTS would reject the EM request for both bonded and non bonded multicast cases.
- When the CM is in EM state and a multicast join request is received, CMTS discards this join request and forces the CM to exit the EM mode.
- When the CM is in EM state and a voice call is in progress, and a new multicast join request is received, CMTS discards this join request and does not force the CM to exit the EM mode since the voice call is in progress.
- There is a threshold for currently handled transactions. When there is multicast join request and the maximum transaction threshold has been reached, CMTS cannot instruct the CM to exit the EM mode. The multicast join is also be denied until the CM can exit the EM mode.
- When the CM is in EM mode and needs to join PacketCable Multimedia (PCMM) multicast, you should send a GateSet request twice, so that the gate can be setup successfully. The first GateSet request only forces the modem to exit the EM mode, but does not set up the gate

### Committed Information Rate

If the QoS is defined by the Minimum Reserved Rate service flow QoS parameter in excess of 200 kbps, when the CM enters into the EM mode, CMTS only provides 200 kbps as the minimum reserved rate. If the minimum reserved rates is less than 200 kbps, CMTS schedules the minimum reserved rate according to the service flow configuration when the CM enters into the EM mode.

CMTS records the Minimum Reserved Rate service flow QoS parameter when the CM enters into the EM mode. When the CM exits the EM mode, CMTS uses the original parameter.

When the CM enters the EM mode, it selects one of the CM upstream channels. If the service flow is completely on that upstream channel, the service flow parameter is not changed. This behavior is because the service flow is not moved into the DBC operation, and the change of the service flow parameter has no benefit

## Admission Control

When a request is received to exit the EM mode and recovery to the original wideband interface is restricted due to an admission control failure, CMTS forces the CM to go offline and re-register to prevent it from getting stuck in the EM mode. In such a case, CMTS logs a warning message.

## Battery Mode

When CMTS receives the status of the CM as operating on battery power, CMTS instructs the CM to enter into the BM. If the CM rejects the instruction received, CMTS keeps the modem in normal status.

When the CM is in BM and CMTS receives the status of the CM as operating on A/C power, CMTS instructs the CM to exit the BM. If the CM rejects the instruction received, CMTS forces the CM to go offline to prevent it from getting stuck in the battery mode. In such a case, CMTS logs a warning message.

## Attribute Mask

When selecting an upstream or a downstream channel pair for energy management mode, CMTS selects channels that meet the requirements of the attribute masks for the existing service flows for the corresponding CM.

In some cases, adherence to the service flow attribute-based assignment may not be possible when selecting an upstream and downstream channel pair for energy management mode of operation. To resolve this conflict, CMTS supports one or both of the following approaches:

1. CMTS may require strict adherence to the required and forbidden attribute masks and thus deny entry into the EM mode if these masks cannot be met by the available individual channels in the MD-CM-SG.
2. CMTS may allow the CM to enter the EM mode while not meeting all the criteria for the attribute masks. In this case, CMTS logs a warning event notifying that the attribute masks are not maintained.

For the following case, CMTS supports approach two:

When the CM is instructed to enter into the EM mode and the selected target upstream and downstream channels do not adhere to the service flow attribute mask. For this conflict CMTS instructs the modem to enter into the EM mode. CMTS also logs a warning message to notify this conflict.

## Dynamic Service Addition

When the CM is in EM mode, DSA request can still be set up even if the requested attributes can not be met with a single channel. In order to not effect voice services, the CM is not forced to exit the EM mode.

## Restrictions for Configuration Change and Interface Shutdown

1. **Shutdown of the upstream channel**—Shutdown of the upstream channel recalculates the MD-US-SG-ID and assigns a new MD-US-SG-ID. In this case, the CM is not offline and internal data structure of the CM instance is not updated. DBC operation checks the MD-US-SG-ID, so when the CM enters into the EM mode there is a mismatch between the MD-US-SD-ID on the CM and the new MD-US-SG-ID. Hence, DBC fails and the CM cannot get into the EM mode.

2. **Change in Upstream Service Group makes the CM in EM mode go offline**—The US-SG configuration change blocks the DBC behavior and the CM gets stuck in the EM mode. To avoid this scenario, when there is a change in the Upstream Service Group (US-SG), such as shutdown or no shutdown of the upstream channels, CMTS makes the CM go offline. The CM should re-register as a normal CM with the wideband channel bonding including multiple channels.
3. **Modify the original wideband interface**—When the CM is in EM mode, change in the original wideband interface channels on the CM makes the CM go offline and re-register as a normal CM.
4. **Disable or enable feature**— When you disable this feature, CMTS does not force CMs to exit from the EM mode unless CMs sends a request. CMTS does not accept EM requests after the EM feature is disabled from the CLI.

## How to Configure the Energy Management Mode

This section describes how to configure the energy management feature on the Cisco cBR-8.

### Contents

## Enabling Energy Management Mode

To enable the energy management mode, complete the following procedure:

```
configure terminal
cable reduction-mode energy-management enable
```

### Verifying the Energy Management Mode

- To verify if the CM is in EM mode, use the **show cable modem** command. If the cable modem is working in energy management mode, the MAC state is displayed with an "em" flag.

```
show cable modem
```

| MAC Address    | IP Address | I/F           | MAC       | Prim          | RxPwr   |
|----------------|------------|---------------|-----------|---------------|---------|
| Timing Num     | I          |               |           |               | State   |
|                | Sid        | (dBmv) Offset | CPE       | P             |         |
| 7cb2.1b0f.ea72 | 1231       | 40.4.58.4     | C7/0/0/UB | w-online (em) | 2 0.00  |
| 54d4.6ffb.2f6b | 1241       | 40.4.58.24    | C7/0/0/UB | w-online      | 3 -0.50 |
| 0025.2ed9.9a22 | 1240       | 40.4.58.3     | C7/0/0/UB | w-online      | 4 0.50  |

- To verify which CM is in EM mode and to get the original wideband and upstream channel information, use the **show cable modem reduction-mode energy-management-mode** command.

```
show cable modem reduction-mode energy-management-mode
```

| I/F      | MAC Address    | ID  | Orig BG I/F | Orig US bitmap | RFs | ID  | Curr BG I/F   |
|----------|----------------|-----|-------------|----------------|-----|-----|---------------|
| Upstream |                |     |             |                |     |     |               |
| C7/0/0   | 0025.2eaf.843e | 897 | Wi7/0/0:0   | 0x3B           | 4   | 252 | Wi7/0/0:1 US0 |

```

C7/0/0 0025.2eaf.8356 897 Wi7/0/0:0 0x3B 4 252 Wi7/0/0:1 US0
C7/0/0 0015.d176.5199 897 Wi7/0/0:0 0x3B 4 252 Wi7/0/0:1 US0

```

## Enabling Energy Management Mode per MAC Domain

CMTS supports the EM feature when enabled both globally and per MAC domain. Use the following procedure to enable energy management feature per MAC domain.

To enable the EM mode per MAC domain, complete the following procedure:

```

configure terminal
interface cable slot/subslot/cable-interface-index
cable reduction-mode energy-management enable

```

## Configuring Initialization Ranging Technique in Dynamic Bonding Channel

The default value for the technique in init-ranging is set to 1 and the valid range is 1-4.

To configure the technique in init-ranging, complete the following procedure:

```

configure terminal
cable reduction-mode energy-management ranging-init-technique value

```

## Configuring the Percentage for the Dynamic Channel Bandwidth

Make sure that you leave enough bandwidth for the primary channel so that it can allocate dynamic channel bandwidth when it joins to a newly created DBG. The default percentage value is set to 5 and the valid range is 1-96.

To configure the percentage of dynamic channel bandwidth, complete the following procedure:

```

configure terminal
cable reduction-mode energy-management dynamic-channel-percent value

```

## Configuring the Queue Size for Energy Management

The default value for the queue size is set to 150 and the valid range is 50-10000.

To set the queue size of the energy management requests, complete the following procedure:

```

configure terminal
cable reduction-mode energy-management process-queue-size value

```

-

## Verifying the Energy Management Mode

This section describes how to verify the EM mode.

## Contents

# Viewing the Basic Statistics for Energy Management Receive Request

To view the basic statistics for all energy management receive request events for a specific CM, use the **show cable modem <cable if | mac\_addr | ip\_addr> reduction-mode energy-management-status** command.

```
show cable modem c8/0/0 reduction-mode energy-management-status
```

| I/F    | MAC Address    | Event         | TID | Count | Error | Dups | Time            |
|--------|----------------|---------------|-----|-------|-------|------|-----------------|
| C8/0/0 | 54d4.6ffb.2e21 | Enter EM mode | 1   | 1     | 0     | 1    | Jul 16 21:38:18 |
|        |                | Exit EM mode  | 1   | 1     | 0     | 0    | Jul 16 21:38:39 |
| C8/0/0 | 602a.d07c.4ec6 | Enter EM mode | 1   | 1     | 0     | 0    | Jul 16 21:40:57 |
|        |                | Exit EM mode  | 1   | 1     | 0     | 0    | Jul 16 21:41:17 |

To clear the basic receive statistics for all EM\_REQ events for a specified CM, use the **clear cable modem <cable if | mac\_addr | ip\_addr> em-status** command.

## Verifying the Configuration Parameters

To verify the configuration parameters used in the CM configuration file, use the **show cable modem <mac address> reduction-mode energy-management-param** command.

```
show cable modem 54d4.6ffb.2e21 reduction-mode energy-management-param
```

```
Energy Management feature enable : Y
DS entry bitrate threshold(bps)   : 100000
DS entry time threshold(s)        : 120
DS exit bitrate threshold(bps)    : 200000
DS exit time threshold(s)         : 2
US entry bitrate threshold(bps)   : 100000
US entry time threshold(s)        : 120
US exit bitrate threshold(bps)    : 200000
US exit time threshold(s)         : 2
cycle period(s)                   : 300
```

## Viewing Information Regarding a Cable Modem

To view all the information regarding a CM, use the **show cable modem mac address verbose** command.

```
show cable modem 54d4.6ffb.30fd verbose
```

```
MAC Address           : 54d4.6ffb.30fd
IP Address            : 40.4.58.14
IPv6 Address          : 2001:40:4:58:741A:408D:7E4B:D7C8
Dual IP               : Y
Prim Sid              : 9
Host Interface        : C7/0/0/UB
MD-DS-SG / MD-US-SG  : 1 / 1
MD-CM-SG              : 0x3C0101
Primary Wideband Channel ID : 897 (Wi7/0/0:0)
Primary Downstream    : In7/0/0:2 (RfId : 722)
Wideband Capable      : Y
RCP Index             : 3
RCP ID                : 00 10 00 00 08
Downstream Channel DCID RF Channel : 99 7/0/0:2
Downstream Channel DCID RF Channel : 97 7/0/0:0
```



```

Downstream Channel DCID RF Channel : 98      7/0/0:1
Downstream Channel DCID RF Channel : 100     7/0/0:3
Multi-Transmit Channel Mode        : Y
Extended Upstream Transmit Power   : 0dB
Upstream Channel                   : US0      US1
Ranging Status                     : sta      sta
Upstream SNR (dB)                  : 36.12   32.55
Upstream Data SNR (dB)             : --      --
Received Power (dBmV)              : 0.00   0.00
Reported Transmit Power (dBmV)     : 25.25  26.00
Peak Transmit Power (dBmV)         : 54.00  54.00
Phy Max Power (dBmV)               : 54.00  54.00
Minimum Transmit Power (dBmV)      : 24.00  24.00
Timing Offset                       (97.6 ns): 1226  1226
Initial Timing Offset              : 1229   973
Rng Timing Adj Moving Avg(0.381 ns): -1      0
Rng Timing Adj Lt Moving Avg       : -7     0
Rng Timing Adj Minimum             : -768   0
Rng Timing Adj Maximum             : 0      64768
Pre-EQ Good                        : 0      0
Pre-EQ Scaled                      : 0      0
Pre-EQ Impulse                     : 0      0
Pre-EQ Direct Loads                : 0      0
Good Codewords rx                  : 515    472
Corrected Codewords rx             : 0      0
Uncorrectable Codewords rx         : 0      0
Phy Operating Mode                 : atdma*  atdma*
sysDescr                           :
Downstream Power                   : 0.00 dBmV (SNR = ----- dB)
MAC Version                        : DOC3.0
QoS Provisioned Mode               : DOC1.1
Enable DOCSIS2.0 Mode              : Y
Modem Status                       : {Modem= w-online(em), Security=disabled}
Capabilities                       : {Frag=N, Concat=N, PHS=Y}
Security Capabilities               : {Priv=, EAE=Y, Key_len=}
L2VPN Capabilities                 : {L2VPN=N, eSAFE=N}
Sid/Said Limit                     : {Max US Sids=16, Max DS Sids=15}
Optional Filtering Support          : {802.1P=N, 802.1Q=N, DUT=N}
Transmit Equalizer Support          : {Taps/Symbol= 1, Num of Taps= 24}
Number of CPE IPs                  : 0 (Max CPE IPs = 16)
CFG Max-CPE                        : 200
Flaps                               : 0()
Errors                             : 0 CRCs, 0 HCSes
Stn Mtn Failures                   : 0 aborts, 0 exhausted
Total US Flows                     : 1(1 active)
Total DS Flows                     : 1(1 active)
Total US Data                      : 7 packets, 2006 bytes
Total US Throughput                 : 0 bits/sec, 0 packets/sec
Total DS Data                      : 5 packets, 1202 bytes
Total DS Throughput                 : 0 bits/sec, 0 packets/sec
LB group ID assigned (index)       : 2151416065 (48131)
LB group ID in config file (index) : N/A (N/A)
LB policy ID                       : 0
LB policy ID in config file        : 0
LB priority                         : 0
Tag                                 :
Required DS Attribute Mask         : 0x0
Forbidden DS Attribute Mask        : 0x0
Required US Attribute Mask         : 0x0
Forbidden US Attribute Mask        : 0x0
Service Type ID                   :
Service Type ID in config file     :
Active Classifiers                  : 2 (Max = NO LIMIT)
CM Upstream Filter Group           : 0

```

```

CM Downstream Filter Group      : 0
CPE Upstream Filter Group      : 0
CPE Downstream Filter Group    : 0
DSA/DSX messages                : permit all
Voice Enabled                   : NO
DS Change Times                 : 0
Boolean Services                : 2
CM Energy Management Capable    : Y
CM Enable Energy Management     : Y
CM Enter Energy Management      : YES
Number of Multicast DSIDs Support : 16
MDF Capability Mode             : 2
IGMP/MLD Version               : MLDv2
FCType10 Forwarding Support    : Y
Features Bitmask                : 0x0
Total Time Online               : 2h12m (2h12m since last counter reset)
CM Initialization Reason        : NO_PRIM_SF_USCHAN
CFG Max IPv6 CPE Prefix        : 16 (-1 used)

```

## Feature Information for Energy Management Mode

Use Cisco Feature Navigator to find information about the platform support and software image support. Cisco Feature Navigator enables you to determine which software images support a specific software release, feature set, or platform. To access Cisco Feature Navigator, go to the <https://cfng.cisco.com/> link. An account on the Cisco.com page is not required.



**Note** The following table lists the software release in which a given feature is introduced. Unless noted otherwise, subsequent releases of that software release train also support that feature.

**Table 111: Feature Information for Downgrading Channel Bonding in Battery Backup Mode**

| Feature Name           | Releases                 | Feature Information                                                              |
|------------------------|--------------------------|----------------------------------------------------------------------------------|
| Energy Management Mode | Cisco IOS XE Fuji 16.7.1 | This feature was integrated on the Cisco cBR Series Converged Broadband Routers. |



## CHAPTER 32

# Cable Modem Steering

The cable modem steering feature helps to redirect or steer cable modems to multiple CMTS routers. A configurable string is used to bond the cable modem to the proper CMTS. Once the bonding is done, the CMTS can move the cable modem within itself for load balancing.

- [Cable Modem Steering on the Cisco cBR Series Converged Broadband Routers, on page 567](#)
- [Prerequisites for Cable Modem Steering, on page 568](#)
- [Restrictions for Cable Modem Steering, on page 568](#)
- [Information About Cable Modem Steering, on page 568](#)
- [How to Configure Cable Modem Steering on the CMTS Router, on page 570](#)
- [Verifying and Troubleshooting Cable Modem Steering, on page 572](#)
- [Additional References, on page 574](#)
- [Feature Information for Cable Modem Steering, on page 575](#)

## Cable Modem Steering on the Cisco cBR Series Converged Broadband Routers

**First Published:** July 13, 2016

The cable modem steering feature helps to redirect or steer cable modems to multiple CMTS routers. A configurable string is used to bond the cable modem to the proper CMTS. Once the bonding is done, the CMTS can move the cable modem within itself for load balancing.

Your software release may not support all the features that are documented in this module. For the latest feature information and caveats, see the release notes for your platform and software release. The Feature Information Table at the end of this document provides information about the documented features and lists the releases in which each feature is supported.

Use Cisco Feature Navigator to find information about platform support and Cisco software image support. To access Cisco Feature Navigator, go to <http://tools.cisco.com/ITDIT/CFN/>. An account on <http://www.cisco.com/> is not required.

## Contents

# Prerequisites for Cable Modem Steering

DOCSIS 3.0-defined type, length, values (TLVs) are required to aid channel selection. All TLVs encoded as general extension information in cable modem configuration files are backward compatible with DOCSIS 1.1 and DOCSIS 2.0 cable modems.



---

**Note** The hardware components introduced in a given Cisco IOS Release are supported in all subsequent releases unless otherwise specified.

---

# Restrictions for Cable Modem Steering

The Cable Modem Steering feature has the following general restrictions:

- To restrict the cable modem on the exact downstream on the target CMTS, the redirection must be configured on the target CMTS.
- You must manually execute the **clear cable modem service-type** command to clear the cable modem service type identifier stored at the CMTS during registration.
- You must manually execute the **clear cable modem attribute-masks** command to clear the cable modem attribute masks stored at the CMTS during registration. These attribute masks are used to restrict usage of upstream channels during ranging time.
- Cable modem steering supports only upstream masks.
- Channel steering does not take place when the cable modem fails in initial ranging.
- The cable modem will take more time to come online when channel steering is deployed. The time taken is proportional to the number of modems, and the downstreams and upstreams that the cable modem can reach.
- A modem cannot be load balanced to any upstream channel with attributes that conflict with attribute masks of the modem.
- Do not configure to use UCC in DOCSIS LBG.

# Information About Cable Modem Steering

Cable modem steering allows you to redirect or steer the cable modems to one or more CMTS routers using downstream frequency overrides. Once a cable modem registers on a downstream on the proper CMTS router, the CMTS router can move the cable modem to any location for load balancing.

The DOCSIS 3.0-compliant Service Type Identifier used as the configurable string in the cable modem configuration file is backward-compatible with DOCSIS 1.1 and DOCSIS 2.0 cable modems.

The CMTS router can also impose restrictions on the number of channels a cable modem can use. DOCSIS 3.0 defines several TLVs to aid the channel selection.

The following TLVs are used in cable modem steering:

- TLV 43.9 (Cable Modem Attribute Masks) limits the set of channels the CMTS router can assign to the cable modem by allowing or forbidding certain binary attributes. The cable modem attribute masks have four sub-TLVs and cable modem steering makes use of two sub-TLVs, which are listed below:
  - TLV 43.9.3—Cable Modem Upstream Required Attribute Mask (C.1.1.18.1.8.3 of CM-SP-MULPIv3.0-I07-080215). It is a 32-bit mask representing the set of binary upstream channel attributes required for the cable modem.
  - TLV 43.9.4—Cable Modem Upstream Forbidden Attribute Mask (C.1.1.18.1.8.4 of CM-SP-MULPIv3.0-I07-080215). It is a 32-bit mask representing the set of binary upstream channel attributes forbidden for the cable modem.
- TLV 43.11 is used for a redirection action based on the service type identifier field. The cable modem sends the TLV 43.11 in the REG-REQ MAC message. The DOCSIS 1.1 and DOCSIS 2.0 modems will also send this file ID when doing the registration.
- TLV 43.1, defined as Policy ID in DOCSIS 2.0 and DOCSIS 3.0, is parsed and stored in the cable modem during registration. Before moving the cable modem during load balancing (LB), the CMTS router checks whether the cable modem has a preconfigured policy with the same Policy ID. If the policy does exist, the CMTS router disables LB for this cable modem and moves to the next cable modem. If the policy does not exist on the CMTS router, or the Policy ID is missing from the cable modem configuration file, LB prohibition is not performed.

The following TLVs are supported in cable modem steering:

- TLV 43.11 (Service type identifier) from section C.1.1.18.1.10 in CM-SP-MULPIv3.0-I07-080215.
- Cable modem attribute masks (TLV 43.9) from C.1.1.18.1.8.3 and C.1.1.18.1.8.4 of CM-SP-MULPIv3.0-I07-080215.
- TLV portion (43.1, Policy ID) of REG-REQ
- TLV 18--- Ranging Hold-off Priority Field
- TLV 19---Channel Class ID

## Upstream Channel Descriptor TLV for Ranging Hold-off

The Upstream Channel Descriptor (UCD) TLV for Ranging Hold-off feature, enables the Cisco cBR Series Converged Broadband router to hold off a cable modem from initial ranging based on TLV 18 and 19 specified in the upstream channel descriptor (UCD) messages. The router can hold off a cable modem from initial ranging only for 5 minutes. This default value cannot be changed. This feature is supported with DOCSIS 2.0 and later releases cable modems using upstream logical channels.

### Ranging Class ID

The CMTS enables UCD TLV for ranging hold-off after detecting the TLVs from the cable modem registration request (REG-REQ) or multipart registration request (REG-REQ-MP), and saves these TLVs as a cable modem ranging class ID.

By default, DOCSIS load balance is supported for all cable modems with all types of ranging class IDs. In the event of DOCSIS load balance, a cable modem moves to the target upstream channel only if the ranging class ID matches with the upstream channel class ID.

### Cable Modem Exclusion for DOCSIS Load Balance

You can exclude a cable modem or a group of cable modems from DOCSIS load balance based on their device type, MAC address, and Organizational Unique Identifier (OUI) using the **cable load-balance exclude** command in global configuration mode.

# How to Configure Cable Modem Steering on the CMTS Router

This section describes the following required and optional procedures:

## Configuring an Upstream Channel Class ID

This configuration is optional. A channel class ID must be configured for an upstream logical channel if you want to configure UCD TLV ranging hold-off on the CMTS router.

### Procedure

|        | Command or Action                                                                                                                                                     | Purpose                                                                                                                                                                                                                                                                                                                                                                                                                                                                                                                                                                                                                                                                                               |
|--------|-----------------------------------------------------------------------------------------------------------------------------------------------------------------------|-------------------------------------------------------------------------------------------------------------------------------------------------------------------------------------------------------------------------------------------------------------------------------------------------------------------------------------------------------------------------------------------------------------------------------------------------------------------------------------------------------------------------------------------------------------------------------------------------------------------------------------------------------------------------------------------------------|
| Step 1 | <b>enable</b><br><b>Example:</b><br>Router> <b>enable</b>                                                                                                             | Enables privileged EXEC mode. <ul style="list-style-type: none"> <li>• Enter your password if prompted.</li> </ul>                                                                                                                                                                                                                                                                                                                                                                                                                                                                                                                                                                                    |
| Step 2 | <b>configure terminal</b><br><b>Example:</b><br>Router# <b>configure terminal</b>                                                                                     | Enters global configuration mode.                                                                                                                                                                                                                                                                                                                                                                                                                                                                                                                                                                                                                                                                     |
| Step 3 | <b>controller upstream-cable</b><br><i>slot/subslot/controller-port-number</i><br><b>Example:</b><br>Router(config)# <b>controller Upstream-Cable 3/0/0</b>           | Specifies the cable interface and enters cable interface configuration mode. Arguments for this command may vary depending on the CMTS router, line card, and Cisco IOS software release. For details, see the <a href="#">Cisco IOS CMTS Cable Command Reference</a> . <ul style="list-style-type: none"> <li>• <i>Slot</i>— Slot where the interface card resides. The valid range is from 0 to 3 and 6 to 9 on the Cisco cBR-8 router.</li> <li>• <i>Subslot</i>—Subslot where the interface card resides. The valid value is 0 on the Cisco cBR-8 router.</li> <li>• <i>controller-port-number</i>—Controller port number. The valid values are from 0 to 7 on the Cisco cBR-8 router.</li> </ul> |
| Step 4 | <b>us-channel</b> <i>us-channel-id</i> <b>chan-class-id</b> <i>id</i><br><b>Example:</b><br>Router(config-controller)# <b>us-channel 3</b><br><b>chan-class-id ff</b> | Configures the channel class ID for an upstream logical channel. <ul style="list-style-type: none"> <li>• <i>us-channel-id</i>—Specifies the upstream channel id.</li> <li>• <i>id</i>—Channel class ID for the logical upstream channel in the hexadecimal format. The valid range is from 0 to ffffffff. The default value is 0.</li> </ul>                                                                                                                                                                                                                                                                                                                                                         |
| Step 5 | <b>end</b><br><b>Example:</b><br>Router(config-controller)# <b>end</b>                                                                                                | Returns to privileged EXEC mode.                                                                                                                                                                                                                                                                                                                                                                                                                                                                                                                                                                                                                                                                      |

## Configuring an Upstream Ranging Hold-off Priority Value

This configuration is optional.

Maximum time that a cable modem can inhibit transmissions on an upstream channel in response to its ranging class ID matching a bit value in the Ranging Hold-off Priority field in the cable modem configuration file is 300 seconds (five minutes) per *DOCSIS 3.0 MAC and Upper Layer Protocols Interface Specification*. This default timer value cannot be changed.

### Procedure

|        | Command or Action                                                                                                                                           | Purpose                                                                                                                                                                                                                                                                                                                                                                                                                                                                                                                                                                                                                                                                                              |
|--------|-------------------------------------------------------------------------------------------------------------------------------------------------------------|------------------------------------------------------------------------------------------------------------------------------------------------------------------------------------------------------------------------------------------------------------------------------------------------------------------------------------------------------------------------------------------------------------------------------------------------------------------------------------------------------------------------------------------------------------------------------------------------------------------------------------------------------------------------------------------------------|
| Step 1 | <b>enable</b><br><b>Example:</b><br>Router> <b>enable</b>                                                                                                   | Enables privileged EXEC mode. <ul style="list-style-type: none"> <li>• Enter your password if prompted.</li> </ul>                                                                                                                                                                                                                                                                                                                                                                                                                                                                                                                                                                                   |
| Step 2 | <b>configure terminal</b><br><b>Example:</b><br>Router# <b>configure terminal</b>                                                                           | Enters global configuration mode.                                                                                                                                                                                                                                                                                                                                                                                                                                                                                                                                                                                                                                                                    |
| Step 3 | <b>controller upstream-cable</b><br><i>slot/subslot/controller-port-number</i><br><b>Example:</b><br>Router(config)# <b>controller upstream-cable 3/0/0</b> | Specifies the cable interface and enters cable interface configuration mode. Arguments for this command may vary depending on the CMTS router, line card, and Cisco IOS software release. For details, see the <a href="#">Cisco IOS CMTS Cable Command Reference</a> . <ul style="list-style-type: none"> <li>• <i>Slot</i>—Slot where the interface card resides. The valid range is from 0 to 3 and 6 to 9 on the Cisco cBR-8 router.</li> <li>• <i>Subslot</i>—Subslot where the interface card resides. The valid value is 0 on the Cisco cBR-8 router.</li> <li>• <i>controller-port-number</i>—Controller port number. The valid values are from 0 to 7 on the Cisco cBR-8 router.</li> </ul> |
| Step 4 | <b>us-channel us-channel-id rng-holdoff priority</b><br><b>Example:</b><br>Router(config-controller)# <b>us-channel 3 rng-holdoff 1</b>                     | Configures the ranging hold-off priority value for an upstream logical channel. <ul style="list-style-type: none"> <li>• <i>us-channel-id</i>—Specifies the upstream channel id.</li> <li>• <b>rng-holdoff priority</b>—Specifies the ranging hold-off priority value in the hexadecimal format. The valid range is from 0 to ffffffff. The default value is 0.</li> </ul>                                                                                                                                                                                                                                                                                                                           |
| Step 5 | <b>end</b><br><b>Example:</b><br>Router(config-controller)# <b>end</b>                                                                                      | Returns to privileged EXEC mode.                                                                                                                                                                                                                                                                                                                                                                                                                                                                                                                                                                                                                                                                     |

# Verifying and Troubleshooting Cable Modem Steering

This section provides the verification and troubleshooting information:

## Verifying an Upstream Ranging Class ID Configuration

To verify an upstream ranging class ID of a cable modem, use the **show cable modem** command with the **verbose** keyword.

Following is a sample output of the **show cable modem verbose** command:

```
Router# show cable modem 68b6.fcfe.22e5 verbose

MAC Address           : 68b6.fcfe.22e5
IP Address            : 192.168.0.8
IPv6 Address          : 2001:DB8:10:1:9951:1972:33F9:9867
Dual IP               : Y
Prim Sid              : 8
Host Interface        : C8/0/0/UB
MD-DS-SG / MD-US-SG  : 1 / 2
MD-CM-SG              : 0x5A0102
Primary Wideband Channel ID : 3073 (Wi8/0/0:0)
Primary Downstream    : Mo8/0/0:0 (RfId : 2304)
Wideband Capable     : Y
RCP Index             : 3
RCP ID                : 00 10 00 00 18
Downstream Channel DCID RF Channel : 45 8/0/0:0
Downstream Channel DCID RF Channel : 46 8/0/0:1
Downstream Channel DCID RF Channel : 47 8/0/0:2
Downstream Channel DCID RF Channel : 48 8/0/0:3
Downstream Channel DCID RF Channel : 49 8/0/0:4
Downstream Channel DCID RF Channel : 50 8/0/0:5
Downstream Channel DCID RF Channel : 51 8/0/0:6
Downstream Channel DCID RF Channel : 52 8/0/0:7
Downstream Channel DCID RF Channel : 53 8/0/0:8
Downstream Channel DCID RF Channel : 54 8/0/0:9
Downstream Channel DCID RF Channel : 55 8/0/0:10
Downstream Channel DCID RF Channel : 56 8/0/0:11
Downstream Channel DCID RF Channel : 57 8/0/0:12
Downstream Channel DCID RF Channel : 58 8/0/0:13
Downstream Channel DCID RF Channel : 59 8/0/0:14
Downstream Channel DCID RF Channel : 60 8/0/0:15
Downstream Channel DCID RF Channel : 61 8/0/0:16
Downstream Channel DCID RF Channel : 62 8/0/0:17
Downstream Channel DCID RF Channel : 63 8/0/0:18
Downstream Channel DCID RF Channel : 64 8/0/0:19
Downstream Channel DCID RF Channel : 65 8/0/0:20
Downstream Channel DCID RF Channel : 66 8/0/0:21
Downstream Channel DCID RF Channel : 67 8/0/0:22
Downstream Channel DCID RF Channel : 68 8/0/0:23
UDC Enabled           : N
Extended Upstream Transmit Power : 61dB
Multi-Transmit Channel Mode : Y
Number of US in UBG  : 8
Upstream Channel      : US0          US1          US2          US3
Ranging Status        : sta          sta          sta          sta
Upstream SNR (dB)     : 30.62         32.32         18.25         24.26
Upstream Data SNR (dB) : --           --           --           --
Received Power (dBmV) : 0.50          0.00         -0.50         -0.50
Reported Transmit Power (dBmV) : 30.75         30.75         29.25         29.25
```



```

Peak Transmit Power (dBmV)      : 61.00      61.00      61.00      61.00
Phy Max Power (dBmV)           : 48.00      48.00      48.00      48.00
Minimum Transmit Power (dBmV)   : 21.00      21.00      21.00      21.00
Timing Offset (97.6 ns)        : 1800      1800      1800      1800
Initial Timing Offset           : 1544      1544      1544      1544
Rng Timing Adj Moving Avg(0.381 ns): -1         0         -1         -1
Rng Timing Adj Lt Moving Avg    : -7         0         -7         -7
Rng Timing Adj Minimum         : -256       0         -256      -256
Rng Timing Adj Maximum         : 65536     65536     65536     65536
Pre-EQ Good                    : 0          0          0          0
Pre-EQ Scaled                  : 0          0          0          0
Pre-EQ Impulse                 : 0          0          0          0
Pre-EQ Direct Loads            : 0          0          0          0
Good Codewords rx              : 1201      1262      833       656
Corrected Codewords rx         : 0          0          169       117
Uncorrectable Codewords rx     : 0          0          205       335
Phy Operating Mode             : atdma*    atdma*    atdma*    atdma*
Upstream Channel               : US4       US5       US6       US7
Ranging Status                 : sta       sta       sta       sta
Upstream SNR (dB)              : 15.53     31.62     31.1      31.87
Upstream Data SNR (dB)        : --        --        --        --
Received Power (dBmV)          : 0.00      0.00      -0.50     0.50
Reported Transmit Power (dBmV) : 29.25     30.75     30.75     30.75
Peak Transmit Power (dBmV)     : 61.00     61.00     61.00     61.00
Phy Max Power (dBmV)           : 48.00     48.00     48.00     48.00
Minimum Transmit Power (dBmV)   : 21.00     21.00     21.00     21.00
Timing Offset (97.6 ns)        : 1800      1800      1800      1800
Initial Timing Offset           : 1544      1800      1544      1544
Rng Timing Adj Moving Avg(0.381 ns): -1        -1         46         0
Rng Timing Adj Lt Moving Avg    : -7        -7        104        0
Rng Timing Adj Minimum         : -256     -256       0          0
Rng Timing Adj Maximum         : 65536     256       65536     65536
Pre-EQ Good                    : 0          0          0          0
Pre-EQ Scaled                  : 0          0          0          0
Pre-EQ Impulse                 : 0          0          0          0
Pre-EQ Direct Loads            : 0          0          0          0
Good Codewords rx              : 718       1328     1173     1252
Corrected Codewords rx         : 110       0          0          0
Uncorrectable Codewords rx     : 298       0          0          0
Phy Operating Mode             : atdma*    atdma*    atdma*    atdma*
sysDescr                       : DOCSIS 3.0 Cable Modem Router
Downstream Power               : 7.40 dBmV (SNR = 43.30 dB)
MAC Version                    : DOC3.0
QoS Provisioned Mode           : DOC1.1
Enable DOCSIS2.0 Mode         : Y
Modem Status                   : {Modem= w-online, Security=disabled}
Capabilities                    : {Frag=N, Concat=N, PHS=Y}
Security Capabilities          : {Priv=, EAE=Y, Key_len=}
L2VPN Capabilities             : {L2VPN=Y, eSAFE=Y}
Sid/Said Limit                 : {Max US Sids=8, Max DS Sids=64}
Optional Filtering Support     : {802.1P=N, 802.1Q=N, DUT=Y}
Transmit Equalizer Support     : {Taps/Symbol= 1, Num of Taps= 24}
Number of CPE                  : 0(Max CPE = 16)
Number of CPE IPs              : 0(Max CPE IPs = 16)
Number of CPE IPv6             : 0(Max CPE IPv6 = 16)
CFG Max-CPE                    : 16
Flaps                           : 19(Oct 11 04:00:25)
Errors                          : 0 CRCs, 0 HCSes
Stn Mtn Failures               : 0 aborts, 12 exhausted
Total US Flows                 : 1(1 active)
Total DS Flows                 : 1(1 active)
Total US Data                  : 3294 packets, 577031 bytes
Total US Throughput            : 0 bits/sec, 0 packets/sec
Total DS Data                  : 2263 packets, 200777 bytes

```

```

Total DS Throughput           : 0 bits/sec, 0 packets/sec
LB group ID assigned (index)  : 2153382146 (55810)
LB group ID in config file (index) : N/A (N/A)
LB policy ID                  : 0
LB policy ID in config file   : 0
LB priority                   : 0
Tag                           :
Required DS Attribute Mask    : 0x0
Forbidden DS Attribute Mask   : 0x0
Required US Attribute Mask    : 0x0
Forbidden US Attribute Mask   : 0x0
Service Type ID              :
Service Type ID in config file :
Ranging Class ID           : 0x2
Active Classifiers            : 0 (Max = NO LIMIT)
CM Upstream Filter Group     : 0
CM Downstream Filter Group   : 0
CPE Upstream Filter Group    : 0
CPE Downstream Filter Group  : 0
DSA/DSX messages             : permit all
Voice Enabled                 : NO
DS Change Times              : 0
Boolean Services             : 2
Number of Multicast DSIDs Support : 63
MDF Capability Mode          : 2
IGMP/MLD Version             : MLDv2
FCType10 Forwarding Support  : Y
Features Bitmask             : 0x0
Total Time Online            : 9h27m (9h27m since last counter reset)
CM Initialization Reason     : BAD_DHCP_ACK
CFG Max IPv6 CPE Prefix      : 16 (-1 used)

```

## Additional References

The following sections provide references related to the Cable Modem Steering feature.

### Related Documents

| Related Topic       | Document Title                                         |
|---------------------|--------------------------------------------------------|
| CMTS cable commands | <a href="#">Cisco IOS CMTS Cable Command Reference</a> |

### Standards and RFCs

| Standard                   | Title                                                            |
|----------------------------|------------------------------------------------------------------|
| CM-SP-MULPIv3.0-I07-080215 | DOCSIS 3.0 MAC and Upper Layer Protocols Interface Specification |
| CM-SP-MULPIv3.0-I18-120329 | DOCSIS 3.0 MAC and Upper Layer Protocols Interface Specification |
| CM-SP-RFI2.0-I13-080215    | DOCSIS 2.0 Radio Frequency Interface Specification               |

**Technical Assistance**

| Description                                                                                                                                                                                                                                                                                                                                                                                                                                                                                                                                                             | Link                                                                                                              |
|-------------------------------------------------------------------------------------------------------------------------------------------------------------------------------------------------------------------------------------------------------------------------------------------------------------------------------------------------------------------------------------------------------------------------------------------------------------------------------------------------------------------------------------------------------------------------|-------------------------------------------------------------------------------------------------------------------|
| <p>The Cisco Support website provides extensive online resources, including documentation and tools for troubleshooting and resolving technical issues with Cisco products and technologies.</p> <p>To receive security and technical information about your products, you can subscribe to various services, such as the Product Alert Tool (accessed from Field Notices), the Cisco Technical Services Newsletter, and Really Simple Syndication (RSS) Feeds.</p> <p>Access to most tools on the Cisco Support website requires a Cisco.com user ID and password.</p> | <a href="http://www.cisco.com/cisco/web/support/index.html">http://www.cisco.com/cisco/web/support/index.html</a> |

## Feature Information for Cable Modem Steering

Use Cisco Feature Navigator to find information about the platform support and software image support. Cisco Feature Navigator enables you to determine which software images support a specific software release, feature set, or platform. To access Cisco Feature Navigator, go to the <https://cfng.cisco.com/> link. An account on the Cisco.com page is not required.



**Note** The following table lists the software release in which a given feature is introduced. Unless noted otherwise, subsequent releases of that software release train also support that feature.

**Table 112: Feature Information for Cable Modem Steering on the Cisco CMTS Routers**

| Feature Name         | Releases                    | Feature Information                                                                                               |
|----------------------|-----------------------------|-------------------------------------------------------------------------------------------------------------------|
| Cable Modem Steering | Cisco IOS XE Everest 16.6.1 | This feature was integrated into Cisco IOS XE Everest 16.6.1 on the Cisco cBR Series Converged Broadband Routers. |





## CHAPTER 33

# DOCSIS Predictive Scheduler

This chapter describes how to configure the DOCSIS Predictive Scheduler (DPS) on the Cisco cBR Series Converged Broadband Router.

- [Information about DOCSIS Predictive Scheduler, on page 577](#)
- [Configuring DPS on Cable Interface, on page 578](#)
- [Displaying DPS Grants on Upstream Channel, on page 578](#)
- [Displaying DPS Grants for Cable Modem, on page 578](#)
- [Displaying Upstream Utilization, on page 579](#)
- [Displaying Upstream Capacity Reserved for Contention Minislot, on page 581](#)
- [DOCSIS Predictive Scheduler Best Practices, on page 581](#)
- [Feature Information for DOCSIS Predictive Scheduler, on page 582](#)

## Information about DOCSIS Predictive Scheduler

DOCSIS Predictive Scheduler (DPS) is a scheduling technique to reduce the DOCSIS upstream latency by predictively allocating unsolicited grants to active service flows.

When enabled, DPS provides benefits to bonded service flows with scheduling service of type Real-Time Polling Service (rtPS), Non-Real-Time Polling Service (nrtPS), and Best Effort (BE).

DPS automatically identifies:

- service flows to which to issue predictive grants
- size of the grants to send
- when to send the grants

Predictive grants are sent after honoring all bandwidth requests received by the CMTS. DPS relies on unallocated MAP capacity to issue predictive grants. Therefore, the less upstream capacity is utilized, the more predictive grants that DPS can issue, and vice-versa.

The upstream latency improvements depend on several factors, such as the difference between the service flow's upstream bitrate and its max-rate, the congestion in the upstream channels, and the predictability of the traffic. In the best-case scenario, latency reductions of 66% are achievable due to a reduction of the request-grant delay from approximately three times the one-way propagation delay to one times the one-way propagation delay. Reductions on the upstream latency translate into upper layer performance improvements depending on the upper layer protocols. For example, reducing the upstream latency in the DOCSIS link may improve the TCP upstream and downstream throughput.

DPS is enabled on per MAC domain basis, and should be configured to issue predictive grants only on the SCQAM channels.

## Configuring DPS on Cable Interface

Use the following steps to configure DPS on a MAC domain:

```
enable
configure terminal
interface cable slot/subslot/interface
cable upstream dps scqam-only
```

DPS configuration is also supported within a MAC domain profile. If you want to configure the number of reserved minislots for contention, use the **cable upstream min-bwreq-ops** command on a per MAC domain basis.

This is a configuration example:

```
Router> enable
Router# configure terminal
Router(config)# interface Cable 7/0/1
Router(config-if)# cable upstream dps scqam-only
Router(config-if)# cable upstream min-bwreq-ops scqam 5 0
```

## Displaying DPS Grants on Upstream Channel

To view the number of bytes granted by DPS on an upstream channel, use the **show controller cable slot/subslot/interface upstream upstream** command as shown in the following example:

```
Router# show controller Cable 1/0/5 upstream 0 | include DPS
DPS Bytes Granted = 27595485909
```



---

**Note** DPS related counters are only displayed when DPS is configured.

---

## Displaying DPS Grants for Cable Modem

DPS grants are issued on a per service flow basis. While a service flow may be allocated with more than one SID, DPS always grants on the SID from the first SID cluster. To determine the service flows and the corresponding SIDs for a given CM, use the **show cable modem mac-address qos** command as shown in the following example:

```
Router# show cable modem 0000.0020.01c0 qos
Sfid  Dir  Curr  Sid  Sched  Prio  MaxSusRate  MaxBrst  MinRsvRate  Throughput
      State      Type
173   US  act   89   BE     6     64000       3044     0           0
2538  US  act   1447 BE     1     120000000   50000    0           0
2539  US  act   1449 BE     1     2200000    50000    0           0
174   DS  act   N/A  N/A    6     64000       96000    0           0
2540  DS  act   N/A  N/A    1     0           65536    0           0
```

```

2541 DS act N/A N/A 1 99000000 10000000 0 0
2542 DS act N/A N/A 1 17600000 65536 0 0

```

To display the number of grants and granted bytes on a per service flow basis, use the **show interface cable slot/subslot/interface sid sid counter verbose** command as shown in the following example (for SFID 173):

```

Router# show interface cable 1/0/5 sid 89 counter verbose
Sid : 89
Request polls issued : 0
BWReqs {Cont,Pigg,RPoll,Other} : 523, 10, 0, 0
Grants issued : 533
Packets received : 1066
Bytes received : 180576
Queue-indicator bit statistics : 0 set, 0 granted
Total Codewords rx : 2073
Good Codewords rx : 2073
Corrected Codewords rx : 0
Uncorrectable Codewords rx : 0
Concatenated headers received : 0
Fragmentation headers received : 0
Fragmentation headers discarded: 0

DPS grants : 0
DPS bytes granted : 0

```



**Note** Two DPS related counters are only displayed when DPS is configured.

## Displaying Upstream Utilization

There are three utilization metrics that can be used to assess the behavior of DPS:

- **%data bytes** (upstream capacity utilization by traffic): If  $t_1$  bytes were sent in the upstream, and the upstream channel capacity was  $c_1$  bytes, then this term refers to  $t_1/c_1$ .
- **%dps grants** (upstream grants scheduled by dps): If  $g_1$  total grant opportunities exist within a map interval, and  $d_1$  grants are issued by DPS, then this term refers to  $d_1/g_1$ .
- **%data grants** (total upstream grants scheduled): If  $g_1$  total grant opportunities exist within a map interval,  $d_1$  grants are issued by DPS and  $b_1$  grants are issued due to bandwidth requests, then this term refers to  $(d_1 + b_1)/g_1$ .

To display the utilization rates on a per upstream channel basis for all three metrics above, use the **show interface cable slot/subslot/interface mac-scheduler** command as shown in the following example.

```

Router# show interface cable 1/0/2 mac-scheduler
DOCSIS 1.1 MAC scheduler for Cable1/0/2/U0 : rate 30720000
wfg:None
us_balance:OFF
dps:ON - SCQAM only
dpon_mode:OFF
fairness:OFF
Queue[Rng Polls] flows 0
Queue[CIR Grants] flows 0
<snip>
Adv Phy Short Grant Slots 128066, Adv Phy Long Grant Slots 29214
Adv Phy UGS Grant Slots 0
Avg upstream channel utilization(%data bytes) : 0%

```

```

Avg upstream channel utilization(%dps grants) : 46%
Avg upstream channel utilization(%data grants) : 46%
Avg upstream channel utilization in 30 sec : 0%
Avg percent contention slots : 53%
Avg percent initial ranging slots : 1%
Avg percent minislots lost on late MAPs : 0%
Avg percent guardband slots : 0%
<snip>

DOCSIS 1.1 MAC scheduler for Cable1/0/2/U1 : rate 30720000
wfg:None
us_balance:OFF
dps:ON - SCQAM only
dpon_mode:OFF
fairness:OFF
Queue[Rng Polls] flows 0
Queue[CIR Grants] flows 0
<snip>
Short Grant Slots 0, Long Grant Slots 0
Adv Phy Short Grant Slots 121745, Adv Phy Long Grant Slots 28446
Adv Phy UGS Grant Slots 0
Avg upstream channel utilization(%data bytes) : 0%
Avg upstream channel utilization(%dps grants) : 40%
Avg upstream channel utilization(%data grants) : 40%
Avg upstream channel utilization in 30 sec : 0%
Avg percent contention slots : 58%
Avg percent initial ranging slots : 1%
Avg percent minislots lost on late MAPs : 0%
Avg percent guardband slots : 0%

Ruoter#show interface cable 1/0/2 mac-scheduler | incl utilization|rate
DOCSIS 1.1 MAC scheduler for Cable1/0/2/U0 : rate 30720000
Avg upstream channel utilization(%data bytes) : 0%
Avg upstream channel utilization(%dps grants) : 95%
Avg upstream channel utilization(%data grants) : 95%
Avg upstream channel utilization in 30 sec : 93%
DOCSIS 1.1 MAC scheduler for Cable1/0/2/U1 : rate 30720000
Avg upstream channel utilization(%data bytes) : 75%
Avg upstream channel utilization(%dps grants) : 95%
Avg upstream channel utilization(%data grants) : 95%
Avg upstream channel utilization in 30 sec : 93%
DOCSIS 1.1 MAC scheduler for Cable1/0/2/U6 : rate 195592784
IUC: 5 rate: 195592784
IUC: 6 rate: 175962768
IUC: 9 rate: 156332752
IUC: 10 rate: 136702736
IUC: 11 rate: 117072712
IUC: 12 rate: 97442704
IUC: 13 rate: 77989528
Avg upstream channel utilization(%data bytes) : 0%
Avg upstream channel utilization(%dps grants) : 0%
Avg upstream channel utilization(%data grants) : 1%
Avg upstream channel utilization in 30 sec : 0%
DOCSIS 1.1 MAC scheduler for Cable1/0/2/U7 : rate 219982848
IUC: 5 rate: 0
IUC: 6 rate: 0
IUC: 9 rate: 0
IUC: 10 rate: 219982848
IUC: 11 rate: 202211312
IUC: 12 rate: 179636656
IUC: 13 rate: 135928256
Avg upstream channel utilization(%data bytes) : 0%
Avg upstream channel utilization(%dps grants) : 0%
Avg upstream channel utilization(%data grants) : 0%
Avg upstream channel utilization in 30 sec : 0%

```





**Note** Data grants based utilization is calculated every 0.5 second, whereas the data bytes based utilization is calculated every 5 seconds for SCQAM channels and every 10 seconds for OFDMA channels.

## Displaying Upstream Capacity Reserved for Contention Minislot

When DPS is enabled, some of the MAP capacity that was previously allocated for contention minislots is now used to issue predictive grants.

To display how much of the upstream capacity is reserved for contention minislots, use the **show interface cable slot/subslot/interface mac-scheduler upstream map-stats | inc bwr** command as shown in the following example:

```
Router#show interface cable 8/0/2 mac-scheduler 0 map-stats | inc bwr
      min_bwr_ops_pct 5.0, min_bwreq_mslot 8 sched min_bwreq_mslot 8
```

**min\_bwr\_ops\_pct** represents the percent of the upstream capacity reserved for the contention minislots.

**min\_bwreq\_mslot** represents the equivalent number of minislots reserved for the contention minislots.

## DOCSIS Predictive Scheduler Best Practices

### MIBs

The CMTS derives the following two MIBs from the data grants allocated in MAPs:

- MIB **docsIf31CmtsUsOfdmaChanUtilization**: Recalculated every 5 seconds
- MIB **docsIfCmtsChannelUtUtilization**: Recalculated every 5 seconds

Both MIBs include DPS related grants.

### Load Balancing

Load balancing uses data grant-based average calculated over a 30-second interval. This average includes the DPS grants.

### Contention Based Bandwidth Requests

Without DPS, as the CMTS adds more data grants in a MAP, the number of bandwidth request opportunities in a MAP decreases. During busy times, this reduction can lead to an increase in upstream latency, either due to collisions, a much larger back-off window (in time), or both.

DPS issues data grants in a MAP at the expense of bandwidth request opportunities. The worst case is when an upstream channel is at full data grants, at which point there is only a single bandwidth request per MAP. To avoid this situation's potential negative effects, we recommend setting the minimum percentage of contention-based bandwidth request opportunities to a non-zero value, e.g., 5%. Tuning may still be needed.

This is a configuration example for SC-QAM:

```
Router> enable
Router# configure terminal
Router(config)# interface Cable 7/0/1
Router(config-if)# cable upstream min-bwreq-ops scqam 5 0
```

This is a configuration example for OFDMA:

```
Router> enable
Router# configure terminal
Router(config)# interface Cable 7/0/1
Router(config-if)# cable upstream min-bwreq-ops ofdma 5 0
```

## MAP Advance Time

The use of DPS increases the MAP build time by up to 50 microseconds per MAP. This additional build time accumulates for each MAP in a MAC domain (a maximum of 16) such that the last MAP can be transmitted as much as 800 microseconds later (than without DPS). Thus, when using DPS, we recommend increasing the MAP Advance parameter. Otherwise, some CMs may transition into partial mode due to late MAPs at the CM, even though the same MAPs would arrive on time at the PHY.

When using dynamic MAP advance, increasing the safety factor from 1200 to 2000 microseconds and the maximum MAP advance from 2000 to 2800 microseconds mitigated the extra MAP build time. Tuning may still be needed.

This is a configuration example:

```
Router> enable
Router# configure terminal
Router(config)# interface Cable 7/0/1
Router(config-if)# cable map-advance dynamic 2000 2800
```

## Cable Modem Interoperability

DOCSIS 3.0 and above CMs are candidates for DPS granting. Some DOCSIS 3.0 CMs do not take advantage of the DPS grants.

## TaFDM

TaFDM and DPS are mutually exclusive and not supported together, since both of them strive to reuse unused upstream capacity on the allocated spectrum.

## Feature Information for DOCSIS Predictive Scheduler

Use Cisco Feature Navigator to find information about the platform support and software image support. Cisco Feature Navigator enables you to determine which software images support a specific software release, feature set, or platform. To access Cisco Feature Navigator, go to the <https://cfnng.cisco.com/> link. An account on the Cisco.com page is not required.



---

**Note** The following table lists the software release in which a given feature is introduced. Unless noted otherwise, subsequent releases of that software release train also support that feature.

---

*Table 113: Feature Information for DOCSIS Predictive Scheduler*

| <b>Feature Name</b>         | <b>Releases</b>                | <b>Feature Information</b>                                                       |
|-----------------------------|--------------------------------|----------------------------------------------------------------------------------|
| DOCSIS Predictive Scheduler | Cisco IOS XE Amsterdam 17.3.1w | This feature was integrated on the Cisco cBR Series Converged Broadband Routers. |





## PART **V**

# Layer 2 and DOCSIS 3.1 Configuration

- [DOCSIS 3.1 OFDM Channel Configuration, on page 587](#)
- [OFDM Channel Power Profile, on page 611](#)
- [DOCSIS 3.1 Path Selection, on page 617](#)
- [DOCSIS 3.1 Downstream Profile Selection, on page 623](#)
- [DOCSIS 3.1 Commanded Power for Upstream SC-QAMs, on page 641](#)
- [DOCSIS3.1 Downstream Resiliency for OFDM channel, on page 647](#)
- [DOCSIS 3.1 OFDMA Channel Configuration, on page 655](#)
- [OFDMA OUDP Leak Detection Configuration, on page 675](#)
- [Time and Frequency Division Multiplexing Configuration, on page 701](#)
- [DOCSIS 3.1 Upstream Profile Selection, on page 707](#)
- [Proactive Network Management, on page 719](#)
- [Downstream Power Tilt, on page 817](#)
- [Controller Profile Configuration, on page 823](#)
- [Voltage Thresholds for AC Power Supply Module Mode Control, on page 839](#)
- [DOCSIS3.1 Downstream Zero Bit Loading, on page 845](#)
- [Reducing Power Consumption, on page 851](#)
- [Low Latency DOCSIS, on page 855](#)





## CHAPTER 34

# DOCSIS 3.1 OFDM Channel Configuration

---

This document describes how to configure the OFDM channel on the Cisco cBR Series Converged Broadband Router.

- [Hardware Compatibility Matrix for the Cisco cBR Series Routers, on page 587](#)
- [Information about OFDM Channel Configuration, on page 589](#)
- [How to Configure OFDM Channel, on page 599](#)
- [Configuration Examples, on page 607](#)
- [Additional References, on page 608](#)
- [Feature Information for DOCSIS 3.1 OFDM Channel Configuration, on page 609](#)

## Hardware Compatibility Matrix for the Cisco cBR Series Routers



---

**Note** The hardware components that are introduced in a given Cisco IOS-XE Release are supported in all subsequent releases unless otherwise specified.

---

Table 114: Hardware Compatibility Matrix for the Cisco cBR Series Routers

| Cisco CMTS Platform                    | Processor Engine                                                                                                                                                                                  | Interface Cards                                                                                                                                                                                                                                                                                                                                                                                                                                                                                                                                                                                                                                                                                                                                                                                 |
|----------------------------------------|---------------------------------------------------------------------------------------------------------------------------------------------------------------------------------------------------|-------------------------------------------------------------------------------------------------------------------------------------------------------------------------------------------------------------------------------------------------------------------------------------------------------------------------------------------------------------------------------------------------------------------------------------------------------------------------------------------------------------------------------------------------------------------------------------------------------------------------------------------------------------------------------------------------------------------------------------------------------------------------------------------------|
| Cisco cBR-8 Converged Broadband Router | <p><b>Cisco IOS-XE Release 16.5.1 and Later Releases</b></p> <p>Cisco cBR-8 Supervisor:</p> <ul style="list-style-type: none"> <li>• PID—CBR-SUP-250G</li> <li>• PID—CBR-CCAP-SUP-160G</li> </ul> | <p><b>Cisco IOS-XE Release 16.5.1 and Later Releases</b></p> <p>Cisco cBR-8 CCAP Line Cards:</p> <ul style="list-style-type: none"> <li>• PID—CBR-LC-8D30-16U30</li> <li>• PID—CBR-LC-8D31-16U30</li> <li>• PID—CBR-RF-PIC</li> <li>• PID—CBR-RF-PROT-PIC</li> <li>• PID—CBR-CCAP-LC-40G</li> <li>• PID—CBR-CCAP-LC-40G-R</li> <li>• PID—CBR-CCAP-LC-G2-R</li> <li>• PID—CBR-SUP-8X10G-PIC</li> <li>• PID—CBR-2X100G-PIC</li> </ul> <p>Digital PICs:</p> <ul style="list-style-type: none"> <li>• PID—CBR-DPIC-8X10G</li> <li>• PID—CBR-DPIC-2X100G</li> </ul> <p>Cisco cBR-8 Downstream PHY Module:</p> <ul style="list-style-type: none"> <li>• PID—CBR-D31-DS-MOD</li> </ul> <p>Cisco cBR-8 Upstream PHY Modules:</p> <ul style="list-style-type: none"> <li>• PID—CBR-D31-US-MOD</li> </ul> |



**Note** Do not use DPICs (8X10G and 2x100G) to forward IP traffic, as it may cause buffer exhaustion, leading to line card reload.

The only allowed traffic on a DPIC interface is DEPI, UEPI, and GCP traffic from the Cisco cBR-8 router to Remote PHY devices. Other traffic such as DHCP, SSH, and UTSC should flow via another router, since DPICs cannot be used for normal routing.



# Information about OFDM Channel Configuration

## OFDM Channels

DOCSIS 3.1 introduces modes for higher throughput and higher spectral efficiency while still allowing backward compatibility to DOCSIS 3.0. The OFDM Channel support includes two OFDM channels per port with channel bandwidth from 24 MHz to 192 MHz wide.

From the Cisco IOS XE Gibraltar 16.10.1d release, the Cisco cBR router supports two OFDM channels per service group for an RPD downstream port. You can configure the channels using the **cable downstream controller-profile** configuration.

cBR-8 routers support 158 SC-QAMs for a single OFDM channel and 128 SC-QAMs for multiple OFDM channels. The max-carrier attribute is automatically set to 158 by default. However, you should set the max-carrier to a value of 128 or below to configure multiple OFDM channels. The Cisco cBR router does not support any value above 128 if you are configuring multiple OFDM channels.

Each OFDM channel supports a control profile, an NCP profile, and up to five data profiles. Profiles support one or more modulations.

You can configure the guard band of an OFDM channel to potentially trade-off some performance margin using command **guardband-override**. By default, Cisco cBR-8 routers use the default guard band, which is based on the roll off and spacing in the OFDM channel profile.

DOCSIS 3.1 OFDM support also allows the user to configure the RF-channels 158–162 under the mac-domain as the primary channel.

### OFDM Channel Configuration

*Table 115: Feature History*

| Feature Name                                     | Release Information         | Feature Description                                                                                                                                                                                                                                   |
|--------------------------------------------------|-----------------------------|-------------------------------------------------------------------------------------------------------------------------------------------------------------------------------------------------------------------------------------------------------|
| Support for the Configuration of 4 OFDM Channels | Cisco IOS XE Dublin 17.12.1 | In this release, you can configure 4 OFDM Channels per Service Group (SG) on cBR-8 routers. 2Gx1G Service Tiers are supported by configuring 4 OFDM channels in each downstream (DS) SG. This feature is supported on KOBOL-R and Cylon-R line cards. |

### Max-carrier Configuration

Max-carrier configuration specifies the maximum number of SCQAM channels of the controller. The combinations of SCQAM and OFDM channels per controller are:

- 1 OFDM + 158 SCQAM;
- 2 OFDM + 128 SCQAM;
- 3 OFDM + 96 SCQAM;

4 OFDM + 64 SCQAM;

```
Router(config)#cable downstream controller-profile 10
Router(config-controller-profile)#max-carrier 158
Router(config-prof-rf-chan)#rf-chan 158
Router(config-prof-rf-chan)#docsis-channel-id 159
Router(config-prof-rf-chan)#9000000 width 96000000 plc 795000000
Router(config-prof-rf-chan)#rf-chan 159
Router(config-prof-rf-chan)#docsis-channel-id 160
Router(config-prof-rf-chan)#5000000 width 96000000 plc 891000000
```

Error: Max-carrier 158 > 128 can support only one OFDM channel.  
Reduce max-carrier to 128 or lower to use 2nd OFDM channel.

### Sample Configuration for Max OFDM Channels

The following example shows a sample configuration:

```
Router#configure terminal
Enter configuration commands, one per line. End with CNTL/Z.

Router(config)#cable downstream controller-profile 104
Router(config-controller-profile)#max-carrier 64
Router(config-controller-profile)#max-ofdm-spectrum 480000000
Router(config-controller-profile)#rf-chan 0 63
Router(config-prof-rf-chan)#type DOCSIS
Router(config-prof-rf-chan)#qam-profile 1
Router(config-prof-rf-chan)#frequency 231000000
Router(config-prof-rf-chan)#rf-output NORMAL
Router(config-prof-rf-chan)#docsis-channel-id 1
Router(config-prof-rf-chan)#rf-chan 158
Router(config-prof-rf-chan)#docsis-channel-id 159
Router(config-prof-rf-chan)#ofdm channel-profile 2 start-frequency 789000000 width 96000000
plc 795000000
Router(config-prof-rf-chan)#rf-chan 159
Router(config-prof-rf-chan)#docsis-channel-id 160
Router(config-prof-rf-chan)#ofdm channel-profile 2 start-frequency 885000000 width 96000000
plc 891000000
Router(config-prof-rf-chan)#rf-chan 160
Router(config-prof-rf-chan)#docsis-channel-id 161
Router(config-prof-rf-chan)#ofdm channel-profile 2 start-frequency 981000000 width 96000000
plc 987000000
The DS controller profile 104 should be applied to RPDs which have capability to support
the same or more number of OFDM channels.

Router(config-prof-rf-chan)#rf-chan 161
Router(config-prof-rf-chan)#docsis-channel-id 162
Router(config-prof-rf-chan)#ofdm channel-profile 20 start-frequency 1077000000 width 96000000
plc 1083000000
The DS controller profile 104 should be applied to RPDs which have capability to support
the same or more number of OFDM channels.

Router(config-prof-rf-chan)#rf-chan 162
Router(config-prof-rf-chan)#docsis-channel-id 163
Router(config-prof-rf-chan)#ofdm channel-profile 2 start-frequency 1173000000 width 96000000
plc 1179000000
Error: Max 4 ofdm channels per controller permitted.
Router(config-prof-rf-chan)#end
```

Use the following command to see the running configuration:

```
Router#sh run | s cable downstream controller-profile 104
```

```

cable downstream controller-profile 104
max-carrier 64
max-ofdm-spectrum 480000000
rf-chan 0 63
  type DOCSIS
  qam-profile 1
  frequency 231000000
  rf-output NORMAL
  docsis-channel-id 1
rf-chan 158
  docsis-channel-id 159
  ofdm channel-profile 2 start-frequency 789000000 width 96000000 plc 795000000
rf-chan 159
  docsis-channel-id 160
  ofdm channel-profile 2 start-frequency 885000000 width 96000000 plc 891000000
rf-chan 160
  docsis-channel-id 161
  ofdm channel-profile 2 start-frequency 981000000 width 96000000 plc 987000000
rf-chan 161
  docsis-channel-id 162
  ofdm channel-profile 20 start-frequency 1077000000 width 96000000 plc 1083000000
rf-chan 162
  docsis-channel-id 163
Router#

```

Use the following command to verify the configuration:

```
Router#show cable downstream controller-profile 104
```

```
Downstream controller-profile 104, type RPHY
```

```
Description:
```

```

Admin: UP
MaxOfdmSpectrum: 480000000
MaxCarrier: 64
Mode: normal
Free freq block list has 3 blocks:
  45000000 - 227999999
  612000000 - 788999999
  1173000000 - 1217999999
DS Splitting: No
OFDM frequency exclusion bands: None

```

```
Configured RF Channels:
```

| Chan | Admin | Frequency | Type   | Annex | Mod | srates | Qam-profile | dcid | output |
|------|-------|-----------|--------|-------|-----|--------|-------------|------|--------|
| 0    | UP    | 231000000 | DOCSIS | B     | 256 | 5361   | 1           | 1    | NORMAL |
| 1    | UP    | 237000000 | DOCSIS | B     | 256 | 5361   | 1           | 2    | NORMAL |
| 2    | UP    | 243000000 | DOCSIS | B     | 256 | 5361   | 1           | 3    | NORMAL |
| 3    | UP    | 249000000 | DOCSIS | B     | 256 | 5361   | 1           | 4    | NORMAL |
| 4    | UP    | 255000000 | DOCSIS | B     | 256 | 5361   | 1           | 5    | NORMAL |
| 5    | UP    | 261000000 | DOCSIS | B     | 256 | 5361   | 1           | 6    | NORMAL |
| 6    | UP    | 267000000 | DOCSIS | B     | 256 | 5361   | 1           | 7    | NORMAL |
| 7    | UP    | 273000000 | DOCSIS | B     | 256 | 5361   | 1           | 8    | NORMAL |
| 8    | UP    | 279000000 | DOCSIS | B     | 256 | 5361   | 1           | 9    | NORMAL |
| 9    | UP    | 285000000 | DOCSIS | B     | 256 | 5361   | 1           | 10   | NORMAL |
| 10   | UP    | 291000000 | DOCSIS | B     | 256 | 5361   | 1           | 11   | NORMAL |
| 11   | UP    | 297000000 | DOCSIS | B     | 256 | 5361   | 1           | 12   | NORMAL |
| 12   | UP    | 303000000 | DOCSIS | B     | 256 | 5361   | 1           | 13   | NORMAL |
| 13   | UP    | 309000000 | DOCSIS | B     | 256 | 5361   | 1           | 14   | NORMAL |
| 14   | UP    | 315000000 | DOCSIS | B     | 256 | 5361   | 1           | 15   | NORMAL |
| 15   | UP    | 321000000 | DOCSIS | B     | 256 | 5361   | 1           | 16   | NORMAL |
| 16   | UP    | 327000000 | DOCSIS | B     | 256 | 5361   | 1           | 17   | NORMAL |
| 17   | UP    | 333000000 | DOCSIS | B     | 256 | 5361   | 1           | 18   | NORMAL |
| 18   | UP    | 339000000 | DOCSIS | B     | 256 | 5361   | 1           | 19   | NORMAL |
| 19   | UP    | 345000000 | DOCSIS | B     | 256 | 5361   | 1           | 20   | NORMAL |
| 20   | UP    | 351000000 | DOCSIS | B     | 256 | 5361   | 1           | 21   | NORMAL |
| 21   | UP    | 357000000 | DOCSIS | B     | 256 | 5361   | 1           | 22   | NORMAL |

|      |       |           |            |          |            |            |      |        |        |
|------|-------|-----------|------------|----------|------------|------------|------|--------|--------|
| 22   | UP    | 363000000 | DOCSIS     | B        | 256        | 5361       | 1    | 23     | NORMAL |
| 23   | UP    | 369000000 | DOCSIS     | B        | 256        | 5361       | 1    | 24     | NORMAL |
| 24   | UP    | 375000000 | DOCSIS     | B        | 256        | 5361       | 1    | 25     | NORMAL |
| 25   | UP    | 381000000 | DOCSIS     | B        | 256        | 5361       | 1    | 26     | NORMAL |
| 26   | UP    | 387000000 | DOCSIS     | B        | 256        | 5361       | 1    | 27     | NORMAL |
| 27   | UP    | 393000000 | DOCSIS     | B        | 256        | 5361       | 1    | 28     | NORMAL |
| 28   | UP    | 399000000 | DOCSIS     | B        | 256        | 5361       | 1    | 29     | NORMAL |
| 29   | UP    | 405000000 | DOCSIS     | B        | 256        | 5361       | 1    | 30     | NORMAL |
| 30   | UP    | 411000000 | DOCSIS     | B        | 256        | 5361       | 1    | 31     | NORMAL |
| 31   | UP    | 417000000 | DOCSIS     | B        | 256        | 5361       | 1    | 32     | NORMAL |
| 32   | UP    | 423000000 | DOCSIS     | B        | 256        | 5361       | 1    | 33     | NORMAL |
| 33   | UP    | 429000000 | DOCSIS     | B        | 256        | 5361       | 1    | 34     | NORMAL |
| 34   | UP    | 435000000 | DOCSIS     | B        | 256        | 5361       | 1    | 35     | NORMAL |
| 35   | UP    | 441000000 | DOCSIS     | B        | 256        | 5361       | 1    | 36     | NORMAL |
| 36   | UP    | 447000000 | DOCSIS     | B        | 256        | 5361       | 1    | 37     | NORMAL |
| 37   | UP    | 453000000 | DOCSIS     | B        | 256        | 5361       | 1    | 38     | NORMAL |
| 38   | UP    | 459000000 | DOCSIS     | B        | 256        | 5361       | 1    | 39     | NORMAL |
| 39   | UP    | 465000000 | DOCSIS     | B        | 256        | 5361       | 1    | 40     | NORMAL |
| 40   | UP    | 471000000 | DOCSIS     | B        | 256        | 5361       | 1    | 41     | NORMAL |
| 41   | UP    | 477000000 | DOCSIS     | B        | 256        | 5361       | 1    | 42     | NORMAL |
| 42   | UP    | 483000000 | DOCSIS     | B        | 256        | 5361       | 1    | 43     | NORMAL |
| 43   | UP    | 489000000 | DOCSIS     | B        | 256        | 5361       | 1    | 44     | NORMAL |
| 44   | UP    | 495000000 | DOCSIS     | B        | 256        | 5361       | 1    | 45     | NORMAL |
| 45   | UP    | 501000000 | DOCSIS     | B        | 256        | 5361       | 1    | 46     | NORMAL |
| 46   | UP    | 507000000 | DOCSIS     | B        | 256        | 5361       | 1    | 47     | NORMAL |
| 47   | UP    | 513000000 | DOCSIS     | B        | 256        | 5361       | 1    | 48     | NORMAL |
| 48   | UP    | 519000000 | DOCSIS     | B        | 256        | 5361       | 1    | 49     | NORMAL |
| 49   | UP    | 525000000 | DOCSIS     | B        | 256        | 5361       | 1    | 50     | NORMAL |
| 50   | UP    | 531000000 | DOCSIS     | B        | 256        | 5361       | 1    | 51     | NORMAL |
| 51   | UP    | 537000000 | DOCSIS     | B        | 256        | 5361       | 1    | 52     | NORMAL |
| 52   | UP    | 543000000 | DOCSIS     | B        | 256        | 5361       | 1    | 53     | NORMAL |
| 53   | UP    | 549000000 | DOCSIS     | B        | 256        | 5361       | 1    | 54     | NORMAL |
| 54   | UP    | 555000000 | DOCSIS     | B        | 256        | 5361       | 1    | 55     | NORMAL |
| 55   | UP    | 561000000 | DOCSIS     | B        | 256        | 5361       | 1    | 56     | NORMAL |
| 56   | UP    | 567000000 | DOCSIS     | B        | 256        | 5361       | 1    | 57     | NORMAL |
| 57   | UP    | 573000000 | DOCSIS     | B        | 256        | 5361       | 1    | 58     | NORMAL |
| 58   | UP    | 579000000 | DOCSIS     | B        | 256        | 5361       | 1    | 59     | NORMAL |
| 59   | UP    | 585000000 | DOCSIS     | B        | 256        | 5361       | 1    | 60     | NORMAL |
| 60   | UP    | 591000000 | DOCSIS     | B        | 256        | 5361       | 1    | 61     | NORMAL |
| 61   | UP    | 597000000 | DOCSIS     | B        | 256        | 5361       | 1    | 62     | NORMAL |
| 62   | UP    | 603000000 | DOCSIS     | B        | 256        | 5361       | 1    | 63     | NORMAL |
| 63   | UP    | 609000000 | DOCSIS     | B        | 256        | 5361       | 1    | 64     | NORMAL |
| Chan | Admin | Mod-Type  | Start      | Width    | PLC        | Profile-ID | dcid | output |        |
|      |       |           | Frequency  |          |            |            |      |        |        |
| 158  | UP    | OFDM      | 789000000  | 96000000 | 795000000  | 2          | 159  | NORMAL |        |
| 159  | UP    | OFDM      | 885000000  | 96000000 | 891000000  | 2          | 160  | NORMAL |        |
| 160  | UP    | OFDM      | 981000000  | 96000000 | 987000000  | 2          | 161  | NORMAL |        |
| 161  | UP    | OFDM      | 1077000000 | 96000000 | 1083000000 | 20         | 162  | NORMAL |        |

Router#

**Note**

- If you configure more than four ofdm channels per controller, then the following message is displayed:  
Error: Max 4 ofdm channels per controller permitted.
- If you configure more than two, three, or four ofdm channels per controller, then the following error message is displayed: The DS controller profile 104 should be applied to RPDs which have capability to support the same or more number of OFDM channels.

## RPD OFDM Capability

Use the following command to obtain how many OFDM channels are supported on the cBR-8 router.

```
Router#show cable rpd 1004.9fb1.0300 capability | i OFDM Channel
Downstream OFDM Channels Per Port : 2
```

The RPD reports the above information.

The number of OFDM channels in the DS controller profile should be less than or equal to the RPD's capability. Use the **cable rphy rpd-capability reject-mismatch** to control whether RPDs with OFDM capability mismatch are online or not. This command is enabled by default. If the command is enabled, then RPDs with OFDM capability mismatch do not become online. You can use **no cable rphy rpd-capability reject-mismatch** command to disable this configuration and to accept the capabilities mismatch and let the RPDs come online, but in this case, the RPDs may behave in a nondeterministic manner.

The following example shows you how to configure the **no cable rphy rpd-capability reject-mismatch** command, accept the capabilities mismatch and let the RPDs come online.

```
Router#show cable rpd 0004.9f31.0979 capability | s Downstream OFDM
Downstream OFDM Channels Per Port : 2
```

```
Router#show cable rpd
MAC Address      IP Address      I/F      State      Role HA  Auth Name
0004.9f31.0979  ---            Te6/1/0  online     Pri Act N/A RPD1
```

```
Router(config)#cable rpd RPD1
Router(config-rpd)# identifier 0004.9f31.0979
Router(config-rpd)# core-interface Te6/1/0
Router(config-rpd-core)# principal
Router(config-rpd-core)#rpd-ds 0 downstream-cable 6/0/3 profile 23
```

```
2023/01/16 12:27:14.953736374 {rphyman_R0-0}{255}: [errmsg] [1630]: UUID: 0, ra: 0 (ERR):
%RPHYMAN-3-RPD_CAPA_PARAM_MISMATCH_ERROR:
R0/0: rphyman: rpd_capa check, rpd_id: 0004.9f31.0979, config_value 3 rpdCapa_value 2,
event: NumDsOfdmChannels mismatch, reject RPD online,
please configure OFDM channels equal to its capability..
```

```
Router#show cable rpd
MAC Address      IP Address      I/F      State      Role HA  Auth Name
0004.9f31.0979  ---            Te6/1/0  offline    Pri Act N/A RPD1
```

After configuring the **no cable rphy rpd-capability reject-mismatch** command, the RPD status displays as **online** as shown in the **show cable rpd** output below.

```
Router(config)#no cable rphy rpd-capability reject-mismatch
```

```
2023/01/16 12:32:13.480653142 {rphyman_R0-0}{255}: [errmsg] [1630]: UUID: 0, ra: 0 (warn):
%RPHYMAN-4-RPD_CAPA_PARAM_MISMATCH_WARNING:
R0/0: rphyman: rpd_capa check, rpd_id: 0004.9f31.0979, config_value 3 rpdCapa_value 2,
event: NumDsOfdmChannels mismatch, accept RPD online,
but it may behave in a non-deterministic manner, suggest configure OFDM channels equal to
its capability.
```

```
Router#show cable rpd
MAC Address      IP Address      I/F      State      Role HA  Auth Name
0004.9f31.0979  ---            Te6/1/0  init(gcp)  Pri Act N/A RPD1
```

```
Router#show cable rpd
MAC Address      IP Address      I/F      State      Role HA  Auth Name
0004.9f31.0979  ---            Te6/1/0  online     Pri Act N/A RPD1
```

See [cable rphy rpd-capability reject-mismatch](#).

## Static Bonding Group

The Maximum OFDM channels count per Static Bonding Group is 2.

```
Router(config-if)#cable rf-channels channel-list 158-159 bandwidth-percent 50
Router(config-if)#do sh run int wi6/0/3:4
Building configuration...
Current configuration : 135 bytes
!
interface Wideband-Cable6/0/3:4
 cable bundle 1
 cable rf-channels channel-list 158-159 bandwidth-percent 50
end
Router(config-if)#cable rf-channels channel-list 160-161 bandwidth-percent 20
Error: Static Bonding Group supports only 2 ofdm channels!!
Router(config-if)#do sh run int wi6/0/3:4
Building configuration...
Current configuration : 135 bytes
interface Wideband-Cable6/0/3:4
 cable bundle 1
 cable rf-channels channel-list 158-159 bandwidth-percent 50
end

Router(config)#cable profile service-group SG
Router(config-profile-sg)#cable bundle 1
Router(config-profile-sg)#mac-domain 0 profile MD1
Router(config-profile-sg-md)#downstream sg-channel 0-3 profile DS1
Router(config-profile-sg-md)#upstream 0 sg-channel 0
Router(config-profile-sg-md)#upstream 1 sg-channel 1
Router(config-profile-sg-md)#upstream 2 sg-channel 2
Router(config-profile-sg-md)#wideband-interface 0 profile BG1
The WB Profile doesn't exist, please create it.
Router(config-profile-sg)#cable profile wideband-interface BG1
Router(config-profile-sg)#cable downstream attribute-mask 80000000
Router(config-profile-sg)#wideband-interface 0 profile BG1
Router(config-profile-sg-bg)#downstream sg-channel 158-160 rf-bandwidth-percent 20
Error: Static Bonding Group supports only 2 ofdm channels!!
Router(config-profile-sg-bg)#downstream sg-channel 158-159 rf-bandwidth-percent 20
Router(config-profile-sg-bg)#do sh run | i bandwidth
downstream sg-channel 0-7 rf-bandwidth-percent 1
downstream sg-channel 8-15 rf-bandwidth-percent 1
downstream sg-channel 16-23 rf-bandwidth-percent 1
downstream sg-channel 24-31 rf-bandwidth-percent 1
downstream sg-channel 24-31 158 rf-bandwidth-percent 1
downstream sg-channel 24-31 rf-bandwidth-percent 1
downstream sg-channel 158-159 rf-bandwidth-percent 20
```

## Dynamic Bonding Group (DBG)

DBG is a feature that creates WB interface dynamically for LB or registration purposes. Max OFDM channel count per DBG is also 2. You can globally enable DBG using the following configuration.

```
Router# cable dynamic-bonding-group
```

Use **no cable dynamic-bonding-group** to disable DBG.

You can also enable Registration or Load Balance separately.

```
Router# cable dynamic-bonding-group registration
```

```
Router# cable dynamic-bonding-group load-balance
```

Use the no form of the command to disable Registration or Load Balance.

```
Router# no cable dynamic-bonding-group registration
```

```
Router# no cable dynamic-bonding-group load-balance
```

The following example is a sample configuration for 64 SCQAM + 4OFDM - SCQAM primary channel

```
Router#show derived-config interface c3/0/0
```

```
Building configuration...
```

```
Derived configuration : 1754 bytes
```

```
!
```

```
interface Cable3/0/0
```

```
  downstream Downstream-Cable 3/0/0 rf-channel 0 profile DS1
  downstream Downstream-Cable 3/0/0 rf-channel 4 profile DS1
  downstream Downstream-Cable 3/0/0 rf-channel 8 profile DS1
  downstream Downstream-Cable 3/0/0 rf-channel 12 profile DS1
  downstream Downstream-Cable 3/0/0 rf-channel 16 profile DS1
  downstream Downstream-Cable 3/0/0 rf-channel 20 profile DS1
  downstream Downstream-Cable 3/0/0 rf-channel 24 profile DS1
  downstream Downstream-Cable 3/0/0 rf-channel 28 profile DS1
  downstream Downstream-Cable 3/0/0 rf-channel 32 profile DS1
  downstream Downstream-Cable 3/0/0 rf-channel 36 profile DS1
  downstream Downstream-Cable 3/0/0 rf-channel 40 profile DS1
  downstream Downstream-Cable 3/0/0 rf-channel 44 profile DS1
  downstream Downstream-Cable 3/0/0 rf-channel 48 profile DS1
  downstream Downstream-Cable 3/0/0 rf-channel 52 profile DS1
  downstream Downstream-Cable 3/0/0 rf-channel 56 profile DS1
```

```
Router#show cable dynamic-bonding-group summary
```

```
Dynamic bonding group: Enable
```

```
DBG operation with Registration: Enable
```

```
DBG operation with Load-Balance: Enable
```

| BG ID | BG Name     | BG Size                  | CMs | ServFlows | Create Time         | Create Client | BG |
|-------|-------------|--------------------------|-----|-----------|---------------------|---------------|----|
| 24577 | Wi3/0/0:0   | 34                       | 12  | 60        | Jun 26 17:12:08.596 | MODEM_ONLINE  |    |
|       | OPERATIONAL | 24608-24639, 24736-24737 |     |           |                     |               |    |
| 24578 | Wi3/0/0:1   | 34                       | 10  | 50        | Jun 26 17:12:19.411 | MODEM_ONLINE  |    |
|       | OPERATIONAL | 24576-24607, 24734-24735 |     |           |                     |               |    |

### Load Balancing (LB)

There are two types of Load Balancing:

- **Static LB:** Balances modem during registration based on the modem count.
- **Dynamic LB:** Balances modem after modem registration based on the traffic or utilization.

Before 4OFDM, LB(SLB and DLB) doesn't change the OFDM channel of the DOCSIS 3.1 modem in modem movement, SLB doesn't move the DOCSIS 3.1 modem when the modem is using OFDM primary channel, and DLB only changes DOCSIS 3.1 modem's SCQAM channel set for balance purpose.

With 4OFDM, LB does balance among 4 OFDM channels, LB changes the modem's OFDM channel set for balance purpose.

There are two rules for DOCSIS 3.1 modem movement in LB.

- If the DOCSIS 3.1 modem uses SCQAM channel as a primary channel, LB only changes the primary channel of the DOCSIS 3.1 modem to SCQAM primary channel, not to OFDM primary channel.
- If the DOCSIS 3.1 modem uses OFDM channel as a primary channel, LB only changes the primary channel of the DOCSIS 3.1 modem to OFDM primary channel, not to SCQAM primary channel.

The following example shows Load-Balancing SG profile:

```
Router# show cable profile service-group
cable profile service-group SG-64
cable bundle 1
mac-domain 0 profile MD1
downstream sg-channel 0 4 8 12 20 24 28 32 36 40 44 48 52 56 profile
upstream 1 sg-channel 0
upstream 1 sg-channel 1
upstream 2 sg-channel 2
upstream 3 sg-channel 4
upstream 4 sg-channel 5
upstream 5 sg-channel 6
upstream 6 sg-channel 7
us-bonding-group 1
upstream 0
upstream 1
upstream 2
upstream 3
us-bonding-group 2
upstream 4
upstream 5
upstream 6
upstream 7
attributes 80000000
```

Router #show cable mac-domain c3/0/0 rcc

| RCC-ID | RCP            | RCs | MD-DS-SG | CMS | WB/RCC-TMPL | D3.0 | D3.1 |
|--------|----------------|-----|----------|-----|-------------|------|------|
| 17     | 00 00 00 00 00 | 34  | 0        | 10  | (Wi3/O/O:0) | N    | Y    |
| 18     | 00 00 00 00 00 | 34  | 0        | 12  | (Wi3/O/O:1) | N    | Y    |

The following example shows DBG Load Balancing:

Router#show cable dynamic-bonding-group summary

```
Dynamic bonding group: Enable
DBG operation with Registration: Enable
DBG operation with Load-Balance: Enable
BG ID BG Name      BG Size  CMS  ServFlows Create Time      Create Client      BG
State             RFid list
24577 Wi3/0/0:0    34      13   65      Jun 26 17:12:08.597  MODEM_ONLINE
OPERATIONAL      24608-24639, 24736-24737
24578 Wi3/0/0:1    34      9    45      Jun 26 17:12:19.412  MODEM_ONLINE
OPERATIONAL      24576-24607, 24734-24735
```

```
video-LWR-S-A4#sh derived-config interface Wi3/0/0:0
Building configuration...
```

```
Derived configuration : 147 bytes
!
interface Wideband-Cable3/0/0:0
 cable bundle 1
 cable rf-channels channel-list 32-63 160-161 bandwidth-percent 1
 no snmp trap link-status
end
```

```
Router#show derived-config interface Wi3/0/0:1
Building configuration...
```

```
Derived configuration : 146 bytes
!
interface Wideband-Cable3/0/0:1
 cable bundle 1
 cable rf-channels channel-list 0-31 158-159 bandwidth-percent 1
```



```
no snmp trap link-status
end
```

The following example shows Static Load Balancing:

```
Router#show cable load-balance
DOCSIS 2.0 LB enabled: Yes
DOCSIS 3.0 LB enabled: Yes
DOCSIS 3.0 Static LB Enabled: Yes
DOCSIS 3.0 Dynamic Downstream LB Enabled: Yes
DOCSIS 3.0 Dynamic Upstream LB Enabled: No

DOCSIS 3.0 general LB
MD      FN  Group ID  S Intv  DCC mask  Policy      Mtd MD-CM-SG  Threshold
      /UCC      D/U      M/E/U/P/S
Ca3/0/0 1  2147557376 E 45    0x08 (4) N 0      m/m 0x90012C  5/10/70/70/50
Ca3/0/0 2  2147557377 E 45    0x08 (4) N 0      m/m 0x900130  5/10/70/70/50
Ca3/0/2 5  2147558404 E 90    0x08 (4) N 0      m/m 0x920401  10/20/70/70/50
Ca3/0/2 5  2147558405 E 90    0x08 (4) N 0      m/m 0x920402  10/20/70/70/50

Router#show cable load-balance docsis-group fn 1 md c3/0/0 load | in Do
Do3/0/0:0(453 MHz)  initial 2147557376 97%(90%/97%) 0% 0 12 37
Do3/0/0:4(477 MHz)  initial 2147557376 97%(90%/97%) 0% 0 12 37
Do3/0/0:8(501 MHz)  initial 2147557376 97%(90%/97%) 0% 0 12 37
Do3/0/0:12(525 MHz) initial 2147557376 97%(90%/97%) 0% 0 12 37
Do3/0/0:16(549 MHz) initial 2147557376 97%(90%/97%) 0% 0 12 37
Do3/0/0:20(573 MHz) initial 2147557376 97%(90%/97%) 0% 0 12 37
Do3/0/0:24(597 MHz) initial 2147557376 97%(90%/97%) 0% 0 12 37
Do3/0/0:28(621 MHz) initial 2147557376 97%(90%/97%) 0% 0 12 37
Do3/0/0:32(645 MHz) initial 2147557376 97%(84%/97%) 0% 0 12 37
Do3/0/0:36(669 MHz) initial 2147557376 97%(84%/97%) 0% 0 12 37
Do3/0/0:40(693 MHz) initial 2147557376 97%(84%/97%) 0% 0 12 37
Do3/0/0:44(717 MHz) initial 2147557376 97%(84%/97%) 0% 0 12 37
Do3/0/0:48(717 MHz) initial 2147557376 97%(84%/97%) 0% 0 12 37
Do3/0/0:52(717 MHz) initial 2147557376 97%(84%/97%) 0% 0 12 37
Do3/0/0:56(717 MHz) initial 2147557376 97%(84%/97%) 0% 0 12 37
```

The following example shows Dynamic Load Balancing:

```
Router# cable load-balance docsis-group fn 49 md c8/0/16 rf
Router#show cable load-balance docsis-group fn 49 md c8/0/16 rfch-util
Load for five secs: 42%/4%; one minute: 45%; five minutes: 50%
Time source is NTP, 22:33:50.525 CST Thu Feb 2 2023
```

| Interface   | Pstate  | Pending-In | Pending-Out | Throughput (Kbps) | Util | NBCM | WBCM |
|-------------|---------|------------|-------------|-------------------|------|------|------|
| Do8/0/16:0  | up      | No         | No          | 15552             | 41%  | 0    | 7    |
| Do8/0/16:1  | NA      | No         | No          | 15592             | 41%  | 0    | 7    |
| Do8/0/16:2  | NA      | No         | No          | 15592             | 41%  | 0    | 7    |
| Do8/0/16:3  | NA      | No         | No          | 15593             | 41%  | 0    | 7    |
| Do8/0/16:4  | up      | No         | No          | 15554             | 41%  | 0    | 7    |
| Do8/0/16:5  | NA      | No         | No          | 15592             | 41%  | 0    | 7    |
| Do8/0/16:6  | NA      | No         | No          | 15591             | 41%  | 0    | 7    |
| Do8/0/16:7  | NA      | No         | No          | 15592             | 41%  | 0    | 7    |
| Do8/0/16:8  | initial | No         | No          | 15554             | 41%  | 0    | 4    |
| Do8/0/16:9  | NA      | No         | No          | 15592             | 41%  | 0    | 4    |
| Do8/0/16:10 | NA      | No         | No          | 15592             | 41%  | 0    | 4    |
| Do8/0/16:11 | NA      | No         | No          | 15592             | 41%  | 0    | 4    |
| Do8/0/16:12 | initial | No         | No          | 15555             | 41%  | 0    | 4    |
| Do8/0/16:13 | NA      | No         | No          | 15593             | 41%  | 0    | 4    |
| Do8/0/16:14 | NA      | No         | No          | 15592             | 41%  | 0    | 4    |
| Do8/0/16:15 | NA      | No         | No          | 15592             | 41%  | 0    | 4    |
| Do8/0/16:16 | up      | No         | No          | 15558             | 41%  | 0    | 8    |
| Do8/0/16:17 | NA      | No         | No          | 15601             | 41%  | 0    | 8    |
| Do8/0/16:18 | NA      | No         | No          | 15601             | 41%  | 0    | 8    |
| Do8/0/16:19 | NA      | No         | No          | 15602             | 41%  | 0    | 8    |
| Do8/0/16:20 | up      | No         | No          | 15557             | 41%  | 0    | 8    |

```

Do8/0/16:21 NA No No 15602 41% 0 8
Do8/0/16:22 NA No No 15602 41% 0 8
Do8/0/16:23 NA No No 15601 41% 0 8
Do8/0/16:24 up No No 15558 41% 0 10
Do8/0/16:25 NA No No 15602 41% 0 10
Do8/0/16:26 NA No No 15602 41% 0 10
Do8/0/16:27 NA No No 15601 41% 0 10
Do8/0/16:28 up No No 15558 41% 0 10
Do8/0/16:29 NA No No 15601 41% 0 10
Do8/0/16:30 NA No No 15601 41% 0 10
Do8/0/16:31 NA No No 15601 41% 0 10
Do8/0/16:32 initial No No 15558 41% 0 4
Do8/0/16:33 NA No No 15600 41% 0 4
Do8/0/16:34 NA No No 15601 41% 0 4
Do8/0/16:35 NA No No 15601 41% 0 4
Do8/0/16:36 initial No No 15558 41% 0 4
Do8/0/16:37 NA No No 15601 41% 0 4
Do8/0/16:38 NA No No 15601 41% 0 4
Do8/0/16:39 NA No No 15601 41% 0 4
Do8/0/16:40 initial No No 15557 41% 0 5
Do8/0/16:41 NA No No 15600 41% 0 5
Do8/0/16:42 NA No No 15600 41% 0 5
Do8/0/16:43 NA No No 15601 41% 0 5
Do8/0/16:44 up No No 15558 41% 0 5
Do8/0/16:45 NA No No 15601 41% 0 5
Do8/0/16:46 NA No No 15600 41% 0 5
Do8/0/16:47 NA No No 15600 41% 0 5
Do8/0/16:158 NA No No 243830 57% 0 8
Do8/0/16:159 NA No No 246994 57% 0 8
Do8/0/16:160 NA No No 0 0% 0 0
Do8/0/16:161 NA No No 0 0% 0 0
Average: 40.38
Variance: 73.575

```

```

Router#show cable load-balance docsis-group fn 49 md c8/0/16 load wideband
Load for five secs: 40%/12%; one minute: 45%; five minutes: 49%
Time source is NTP, 22:37:52.939 CST Thu Feb 2 2023
DOCSIS load-balancing wideband load

```

| Interface   | Size | Group      | Throughput (Kbps) /bw (Mbps) | Avg-Util |
|-------------|------|------------|------------------------------|----------|
| Wi8/0/16:3  | 34   | 2147639344 | 951416/2113                  | 63%      |
| Wi8/0/16:4  | 8    | 2147639344 | 0/300                        | 38%      |
| Wi8/0/16:18 | 8    | 2147639344 | 0/300                        | 33%      |
| Wi8/0/16:19 | 8    | 2147639344 | 0/300                        | 38%      |
| Wi8/0/16:20 | 8    | 2147639344 | 0/300                        | 33%      |
| Wi8/0/16:21 | 34   | 2147639344 | 542868/2113                  | 62%      |
| Wi8/0/16:22 | 8    | 2147639344 | 0/300                        | 38%      |
| Wi8/0/16:23 | 34   | 2147639344 | 896826/2062                  | 61%      |

### Data Rate Unit Setting TLV

The service flow and ASF QoS parameters include a few 32-bit rates (Maximum Sustained Traffic Rate, Minimum Reserved Traffic Rate, Peak Traffic Rate, and Guaranteed Grant Rate). By default, the rates are in bits per second (bps). As the result, the rate configuration is capped at 4 Gbps. 4xOFDM BG supports a higher rate than 4Gbps.

The **Data Rate Unit Setting TLV**, [24/25/70/71].41, is introduced in the D31 spec. It applies to both Upstream and Downstream Service Flow or Aggregate Service Flow parameters. The value of the **Data Rate Unit Setting TLV** overwrites the default unit (bps) for all these rate TLVs of a flow and allows for their interpretation in units of bps (0), or kbps (1), or Mbps (2) or Gbps (3).

Starting with Cisco IOS XE Dublin 17.12.1z, **Data Rate Unit Setting** TLV is supported on downstream SF/ASF. It can be configured using a CM configuration file or SCN/AQP. Use the following commands to configure **Data Rate Unit Setting**:

- **cable service class 100 data-rate-unit *data-rate*** . The range is 0–3. 0=bps, 1=kbps, 2=Mbps, 3=Gbps.
- **cable asf-qos-profile data-rate-unit *data-rate*** . The range is 0–3. 0=bps, 1=kbps, 2=Mbps, 3=Gbps.

## Channel Profile

A globally configured OFDM channel profile contains channel parameters, and the modulation or modulation profile associated with the control, NCP, and data profiles.

Each OFDM channel must specify an OFDM channel profile in its configuration.

## Modulation Profile

A globally configured OFDM modulation profile assigns different modulations to ranges of sub-carriers, or lists of individual sub-carriers.

A modulation profile may be assigned to a control, NCP, or data profile in a channel profile.

## OFDM Channel Exclusion Band

Ranges of frequencies can be excluded from all OFDM channels on a port using the **ofdm-freq-excl-band** command.

# How to Configure OFDM Channel

## Configuring OFDM Modulation Profile

To configure the OFDM modulation profile, follow the steps below:

```
enable
configure terminal
cable downstream ofdm-modulation-profile id
description text
subcarrier-spacing value
width value
start-frequency value
assign {modulation-default mod_prof_id | modulation mod_prof_id {list-subcarriers
{freq-abs | freq-offset} value | range-subcarriers {freq-abs | freq-offset}
value width value}}
```



**Note** Subcarrier spacing must match the subcarrier spacing of each channel profile in which it is configured.

## Verifying OFDM Modulation Profile Configuration

To display the OFDM modulation profile details, use the **show cable ofdm-modulation-profiles** command as shown in the example below:

```
Router# show cable ofdm-modulation-profile 10

**** OFDM Modulation Profile Configuration ****

Prof  FFT  Width      Start-freq Modulations
ID   KHz  Hz         Hz
10   50   96000000  627000000  64  default
                                     512  freq-abs  709050000 width  12000000
                                     2048 freq-abs  629000000 width   6000000

Profile Subcarrier Modulations
Modulation: Start-freq-abs[start-sc] - End-freq-abs[end-sc] Width-freq[num-sc]
64  : 572600000[  0] - 626950000[1087]  54400000[1088]
64  : 627000000[1088] - 628950000[1127]  2000000[ 40]
2048: 629000000[1128] - 634950000[1247]  6000000[ 120]
64  : 635000000[1248] - 709000000[2728]  74050000[1481]
512 : 709050000[2729] - 721000000[2968]  12000000[ 240]
64  : 721050000[2969] - 722950000[3007]  1950000[ 39]
64  : 723000000[3008] - 777350000[4095]  54400000[1088]

**** OFDM Modulation Profile Assigned Channel Profiles ****

Prof  Channel
ID   Profiles
10   30
```

To display the associations between OFDM modulation profiles and OFDM channel profiles, use the **show cable ofdm-modulation-profile** command with **channel-profiles** option as shown in the example below:

```
Router# show cable ofdm-modulation-profile channel-profiles

**** OFDM Modulation Profile Assigned Channel Profiles ****

Prof  Channel
ID   Profiles
8     None
9     28
10    30
192   192
```

To display the OFDM modulation profile configurations, use the **show cable ofdm-modulation-profile** command with **configuration** option as shown in the example below:

```
Router# show cable ofdm-modulation-profile configuration

**** OFDM Modulation Profile Configuration ****

Prof  FFT  Width      Start-freq Modulations      Description
ID   KHz  Hz         Hz
8     50   192000000  NA          2048 default                (Limited to 20)
                                     512  freq-off  48000000
                                     width  24000000
9     50   96000000  627000000  512  default                512-1k-4k
                                     1024 freq-abs  635000000
                                     width  74050000
                                     4096 freq-abs  629000000
                                     width  6000000
```

```

10      50      96000000  627000000  64      default
                    512      freq-abs  709050000
                    width      12000000
                    2048      freq-abs  629000000
                    width      6000000

```

## Configuring OFDM Channel Profile

To configure the OFDM channel profile, follow the steps below:

```

enable
configure terminal
cable downstream ofdm-chan-profile id
description text
cyclic-prefix value
interleaver-depth value
pilot-scaling value
roll-off value
subcarrier-spacing value
profile-ncp modulation-default mod_prof_id
profile-control {modulation-default mod_prof_id | modulation-profile mod_prof_id}
profile-data channel_data_prof_id {modulation-default mod_prof_id |
modulation-profile mod_prof_id}

```

## Verifying OFDM Channel Profile Configuration

To display the OFDM channel profile details, use the **show cable ofdm-chan-profiles** command as shown in the example below:

```

Router# show cable ofdm-chan-profile 20

**** OFDM Channel Profile Configuration ****

Prof  Cycl  Roll  FFT  Intr  Pilot  Modulation (D-Default, P-Profile)
ID    Prfx  Off   KHz  Depth Scale Cntrl  NCP      Data Profiles
   1      2      3      4      5

20    1024  128   50   16    48    D:1024 D:16   NA     NA     NA     NA     NA
**** OFDM Channel Profile Assigned Channels ****

Prof  Admin  Controller:channels
ID
20    Up     3/0/1:158           3/0/2:158           3/0/3:158           3/0/5:158
                               3/0/6:158           3/0/7:158

```

To display the associations between OFDM channel profiles and OFDM channels, use the **show cable ofdm-chan-profiles** command with **channels** option as shown in the example below:

```

Router# show cable ofdm-chan-profile channels

**** OFDM Channel Profile Assigned Channels ****

Prof  Admin  Controller:channels
ID

```

```

20    Up    3/0/1:158          3/0/2:158          3/0/3:158          3/0/5:158
      3/0/6:158          3/0/7:158
30    Up    3/0/4:158
101   Up    3/0/0:158

```

To display the OFDM channel profile configurations, use the **show cable ofdm-chan-profiles** command with **configuration** option as shown in the example below:

```
Router# show cable ofdm-chan-profile configuration
```

```
**** OFDM Channel Profile Configuration ****
```

| Prof<br>ID                     | Cycl<br>Prfx | Roll<br>Off | FFT<br>KHz | Intr<br>Depth | Pilot<br>Scale | Modulation (D-Default, P-Profile)<br>Cntrl | NCP  | Data Profiles |        |       |    |    |    |
|--------------------------------|--------------|-------------|------------|---------------|----------------|--------------------------------------------|------|---------------|--------|-------|----|----|----|
| Description<br>(Limited to 20) |              |             |            |               |                |                                            |      | 1             | 2      | 3     | 4  | 5  |    |
| 0                              | 192          | 128         | 50         | 16            | 48             | D:256                                      | D:16 | D:1024        | NA     | NA    | NA | NA | NA |
| System Profile 0               |              |             |            |               |                |                                            |      |               |        |       |    |    |    |
| 1                              | 192          | 128         | 50         | 16            | 48             | D:256                                      | D:16 | D:1024        | D:2048 | D:512 | NA | NA | NA |
| System Profile 1               |              |             |            |               |                |                                            |      |               |        |       |    |    |    |
| 20                             | 1024         | 128         | 50         | 16            | 48             | D:1024                                     | D:16 | NA            | NA     | NA    | NA | NA | NA |
| 30                             | 1024         | 128         | 50         | 16            | 48             | P:10                                       | D:16 | NA            | NA     | NA    | NA | NA | NA |

## Configuring OFDM Channel as Primary Channel

To configure an RF-channel in the mac-domain as an OFDM primary channel, use the following commands.

```

enable
configure terminal
interface cable <slot/subslot/port> downstream Integrated-Cable <slot/subslot/port>
rf-channel <ofdm-channel-number: 158-162>
end

```

## Verifying OFDM Primary Channel Configuration

To display the OFDM channel configuration details, where the OFDM channel is the primary channel, use the command as shown in the following example:

```

Router#sh run int c3/0/3
Building configuration...

Current configuration : 539 bytes
!
interface Cable3/0/3
 load-interval 30
 downstream Integrated-Cable 3/0/3 rf-channel 0
 downstream Integrated-Cable 3/0/3 rf-channel 158
 upstream 0 Upstream-Cable 3/0/6 us-channel 0
 upstream 1 Upstream-Cable 3/0/6 us-channel 1
 upstream 2 Upstream-Cable 3/0/6 us-channel 2
 upstream 3 Upstream-Cable 3/0/6 us-channel 3
 cable upstream bonding-group 1
  upstream 0
  upstream 1
  upstream 2
  upstream 3

```

```

attributes 80000000
cable bundle 1
cable cm-status enable 3 6-11 16-18 20-27
cable privacy accept-self-signed-certificate
end

```

You can also use the following command to display the OFDM primary channel configuration details as shown in this example.

```

Router#sh cable mac-domain c3/0/3 cgd-associations
CGD Host  Resource  DS Channels  Upstreams  (ALLUS)  Active DS
Ca3/0/3   3/0/3         0           0-3        Yes       0
           158           0-3        Yes       158

```

The **show cable mac-domain Cable <slot>/<subslot>/<port> mdd** command also displays the OFDM primary channel configuration details as shown in the example.

```

...
Downstream Active Channel List
Channel ID:           159
Frequency:            836000000Hz
Primary Capable:     Primary-Capable
CM-STATUS Event Bitmask:0x36
                      MDD Timeout
                      QAM FEC failure
                      MDD Recovery
                      QAM FEC recovery
MAP/UCD Transport Indicator: Can carry MAPs and UCDs
OFDM PLC Params Bitmask:
  Tukey raised cosine window: 0.625
  Cyclic Prefix: 5.0
  Sub carrier spacing: 50

```

RF channels use a zero-based numbering scheme, whereas the downstream channel IDs are numbered starting from one. Thus RF channel 158 is equivalent to channel ID 159. The Channel ID in this example is 159. The MAP/UCD Transport Indicator shows that MAPs and UCDs are sent only on Primary Channels.

## Configuring Port or Controller and Channel

To configure the port/controller and channel, use the following commands:

```

enable
configure terminal
controller integrated-cable slot/subslot/port
max-ofdm-spectrum value
ofdm-freq-excl-band start-frequency value width value
rf-chan start_id [end_id]
ofdm channel-profile id start-frequency value width value [plc value]

```



**Note** The range of *start\_id* is 158 to 162 in the OFDM channel configuration.

The maximum OFDM spectrum is assigned to OFDM channels, which is used by the the CMTS to calculate default port base power.

Ranges of frequencies can be excluded from all OFDM channels using the **ofdm-freq-excl-band** command.

## Verifying Port/Controller and Channel Configuration

To display the RF port details, use the **show controller integrated-cable** command with **rf-port** option as shown in the example below:

```
Router# show controller integrated-cable 3/0/0 rf-port

Admin: UP MaxCarrier: 128 BasePower: 33 dBmV Mode: normal
Rf Module 0: UP
Free freq block list has 3 blocks:
  45000000 - 107999999
  624000000 - 644999999
  837000000 - 1217999999
Rf Port Status: UP
MaxOfdmSpectrum: 192000000 Equivalent 6MHz channels: 32
UsedOfdmSpectrum: 192000000 AvailOfdmSpectrum: 0
DefaultBasePower: 33 dBmV Equivalent 6MHz channels: 160
OFDM frequency exclusion bands: None
```

To display the summary information on OFDM channel, use the **show controller integrated-cable** command with **rf-channel** option as shown in the example below:

```
Router# show controller integrated-cable 3/0/0 rf-channel 158

Chan State Admin Mod-Type Start Width PLC Profile-ID dcid power
output
                                Frequency
 158 UP UP OFDM 627000000 96000000 663000000 20 159 34
NORMAL
```

To display detailed information on OFDM channel, use the **show controller integrated-cable** command with **rf-channel** and **verbose** options as shown in the example below:

```
Router# show controller integrated-cable 3/0/0 rf-channel 158 verbose

Chan State Admin Mod-Type Start Width PLC Profile-ID dcid power
output
                                Frequency
 158 UP UP OFDM 627000000 96000000 663000000 30 159 32
NORMAL
Resource status: OK
License: granted <17:02:35 EDT May 18 2016>
OFDM channel license spectrum width: 92200000
OFDM modulation license (spectrum width): 2K (6000000)
OFDM config state: Configured

OFDM channel details: [3/0/4:158]
-----
OFDM channel frequency/subcarrier range : 627000000[1088] - 722999999[3007]
OFDM spectrum frequency/subcarrier range : 572600000[ 0] - 777399999[4095]
Active spectrum frequency/subcarrier range : 628900000[1126] - 721049999[2969]
OFDM channel center frequency/subcarrier : 675000000[2048]
PLC spectrum start frequency/subcarrier : 663000000[1808]
PLC frequency/subcarrier : 665800000[1864]
Channel width : 96000000
Active Channel width : 92200000
OFDM Spectrum width : 204800000
Chan prof id : 30
Cyclic Prefix : 1024
Roll off : 128
Interleave depth : 16
Spacing : 50KHZ
```



```

Pilot Scaling : 48
Control modulation profile : 10
NCP modulation default : 16
Data modulation default : None
Data modulation profile : None
Lower guardband width in freq/subcarriers : 1900000[38]
Upper guardband width in freq/subcarriers : 1900000[38]
Licensed 4K modulation spectrum width : 0
Licensed 2K modulation spectrum width : 6000000

PLC spectrum frequencies [subcarriers] :
663000000[1808] - 668999999[1927]

PLC channel frequencies [subcarriers] :
665800000[1864] - 666199999[1871] Size: 8 subcarriers

Excluded frequencies [subcarriers] :
572600000[ 0] - 628899999[1125] 721100000[2970] - 777399999[4095]
Count: 2252

Pilot frequencies [subcarriers] :
*:PLC pilots
630700000[1162] 634300000[1234] 637900000[1306] 641500000[1378]
645100000[1450] 648700000[1522] 652300000[1594] 655900000[1666]
659500000[1738] 663450000[1817]* 664050000[1829]* 664600000[1840]*
665050000[1849]* 666900000[1886]* 667350000[1895]* 667900000[1906]*
668500000[1918]* 669100000[1930] 672700000[2002] 676300000[2074]
679900000[2146] 683500000[2218] 687100000[2290] 690700000[2362]
694300000[2434] 697900000[2506] 701500000[2578] 705100000[2650]
708700000[2722] 712300000[2794] 715900000[2866] 719500000[2938]
Count: 32

Active frequencies [subcarriers] :
628900000[1126] - 721099999[2969]
Count: 1844

Data frequencies [subcarriers] :
628900000[1126] - 630699999[1161] 630750000[1163] - 634299999[1233]
634350000[1235] - 637899999[1305] 637950000[1307] - 641499999[1377]
641550000[1379] - 645099999[1449] 645150000[1451] - 648699999[1521]
648750000[1523] - 652299999[1593] 652350000[1595] - 655899999[1665]
655950000[1667] - 659499999[1737] 659550000[1739] - 663449999[1816]
663500000[1818] - 664049999[1828] 664100000[1830] - 664599999[1839]
664650000[1841] - 665049999[1848] 665100000[1850] - 665799999[1863]
666200000[1872] - 666899999[1885] 666950000[1887] - 667349999[1894]
667400000[1896] - 667899999[1905] 667950000[1907] - 668499999[1917]
668550000[1919] - 669099999[1929] 669150000[1931] - 672699999[2001]
672750000[2003] - 676299999[2073] 676350000[2075] - 679899999[2145]
679950000[2147] - 683499999[2217] 683550000[2219] - 687099999[2289]
687150000[2291] - 690699999[2361] 690750000[2363] - 694299999[2433]
694350000[2435] - 697899999[2505] 697950000[2507] - 701499999[2577]
701550000[2579] - 705099999[2649] 705150000[2651] - 708699999[2721]
708750000[2723] - 712299999[2793] 712350000[2795] - 715899999[2865]
715950000[2867] - 719499999[2937] 719550000[2939] - 721099999[2969]
Count: 1804

Profiles:
Number of profiles: 2
CTRL profile (Profile A): rate: 461916 kbps, usable rate: 368000 kbps
Active frequencies [subcarriers]:
Modulation:Start-freq[start-subcarrier] - End-freq[end-subcarrier]
-----
64 :628900000[1126] - 628950000[1127] 2048 :629000000[1128] - 630650000[1161]
2048 :630750000[1163] - 634250000[1233] 2048 :634350000[1235] - 634950000[1247]

```

## Verifying Port/Controller and Channel Configuration

```

64 :635000000[1248] - 637850000[1305]      64 :637950000[1307] - 641450000[1377]
64 :641550000[1379] - 645050000[1449]      64 :645150000[1451] - 648650000[1521]
64 :648750000[1523] - 652250000[1593]      64 :652350000[1595] - 655850000[1665]
64 :655950000[1667] - 659450000[1737]      64 :659550000[1739] - 663400000[1816]
64 :663500000[1818] - 664000000[1828]      64 :664100000[1830] - 664550000[1839]
64 :664650000[1841] - 665000000[1848]      64 :665100000[1850] - 665750000[1863]
64 :666200000[1872] - 666850000[1885]      64 :666950000[1887] - 667300000[1894]
64 :667400000[1896] - 667850000[1905]      64 :667950000[1907] - 668450000[1917]
64 :668550000[1919] - 669050000[1929]      64 :669150000[1931] - 672650000[2001]
64 :672750000[2003] - 676250000[2073]      64 :676350000[2075] - 679850000[2145]
64 :679950000[2147] - 683450000[2217]      64 :683550000[2219] - 687050000[2289]
64 :687150000[2291] - 690650000[2361]      64 :690750000[2363] - 694250000[2433]
64 :694350000[2435] - 697850000[2505]      64 :697950000[2507] - 701450000[2577]
64 :701550000[2579] - 705050000[2649]      64 :705150000[2651] - 708650000[2721]
64 :708750000[2723] - 709000000[2728]      512 :709050000[2729] - 712250000[2793]
512 :712350000[2795] - 715850000[2865]      512 :715950000[2867] - 719450000[2937]
512 :719550000[2939] - 721000000[2968]      64 :721050000[2969] - 721050000[2969]
Active subcarrier count: 1804, ZBL count: 0
Discontinuity time [days:hours:mins:secs]: 00:00:54:32 [16:15:02 EDT May 18 2016]

```

## NCP profile:

Active frequencies [subcarriers]:

Modulation:Start-freq[start-subcarrier] - End-freq[end-subcarrier]

```

-----
16 :628900000[1126] - 630650000[1161]      16 :630750000[1163] - 634250000[1233]
16 :634350000[1235] - 637850000[1305]      16 :637950000[1307] - 641450000[1377]
16 :641550000[1379] - 645050000[1449]      16 :645150000[1451] - 648650000[1521]
16 :648750000[1523] - 652250000[1593]      16 :652350000[1595] - 655850000[1665]
16 :655950000[1667] - 659450000[1737]      16 :659550000[1739] - 663400000[1816]
16 :663500000[1818] - 664000000[1828]      16 :664100000[1830] - 664550000[1839]
16 :664650000[1841] - 665000000[1848]      16 :665100000[1850] - 665750000[1863]
16 :666200000[1872] - 666850000[1885]      16 :666950000[1887] - 667300000[1894]
16 :667400000[1896] - 667850000[1905]      16 :667950000[1907] - 668450000[1917]
16 :668550000[1919] - 669050000[1929]      16 :669150000[1931] - 672650000[2001]
16 :672750000[2003] - 676250000[2073]      16 :676350000[2075] - 679850000[2145]
16 :679950000[2147] - 683450000[2217]      16 :683550000[2219] - 687050000[2289]
16 :687150000[2291] - 690650000[2361]      16 :690750000[2363] - 694250000[2433]
16 :694350000[2435] - 697850000[2505]      16 :697950000[2507] - 701450000[2577]
16 :701550000[2579] - 705050000[2649]      16 :705150000[2651] - 708650000[2721]
16 :708750000[2723] - 712250000[2793]      16 :712350000[2795] - 715850000[2865]
16 :715950000[2867] - 719450000[2937]      16 :719550000[2939] - 721050000[2969]
Active subcarrier count: 1804, ZBL count: 0

```

## CCCs:

OCD CCC: 2

DPD CCCs:

Control profile (Profile A) CCC: 2

NCP profile CCC: 2

Resource config time taken: 2286 msecs

JIB channel number: 776

| Chan      | Pr | EnqQ | Pipe | RAF  | SyncTmr | DqQ | ChEn | RAF   | Pipe | Phy0 | Phy1 | Tun# | SessId | 0[TkbRt   | MaxP]   |
|-----------|----|------|------|------|---------|-----|------|-------|------|------|------|------|--------|-----------|---------|
| 776       | 0  | 384  | 1    | 725  | 0       | 384 | 0100 | 13032 | 1    | 0    | 1    | 2    | 0      | 479610000 | 4485120 |
| 383688000 |    |      |      |      |         |     |      |       |      |      |      |      |        |           |         |
| 776       | 1  | 384  | 1    | 4786 | 0       | 384 | 0100 | 2190  | 1    | 0    | 1    | 2    | 0      | 479610000 | 4485120 |
| 383688000 |    |      |      |      |         |     |      |       |      |      |      |      |        |           |         |
| 776       | 2  | 384  | 1    | 4786 | 0       | 384 | 0100 | 2190  | 1    | 0    | 1    | 2    | 0      | 479610000 | 4485120 |
| 383688000 |    |      |      |      |         |     |      |       |      |      |      |      |        |           |         |
| 776       | 3  | 384  | 1    | 4786 | 0       | 384 | 0100 | 2190  | 1    | 0    | 1    | 2    | 0      | 479610000 | 4485120 |
| 383688000 |    |      |      |      |         |     |      |       |      |      |      |      |        |           |         |
| 776       | 4  | 384  | 1    | 4786 | 0       | 384 | 0100 | 2190  | 1    | 0    | 1    | 2    | 0      | 479610000 | 4485120 |
| 383688000 |    |      |      |      |         |     |      |       |      |      |      |      |        |           |         |

```

776 5 384 1 4786 0 384 0100 2190 1 0 1 2 0 479610000 4485120
383688000 4485120
776 6 384 1 4786 0 384 0100 2190 1 0 1 2 0 479610000 4485120
383688000 4485120
776 7 384 1 0 0 384 0100 0 1 0 1 2 0 479610000 4485120
383688000 4485120

```

```

Chan  Qos-Hi  Qos-Lo  Med-Hi  Med-Lo  Low-Hi  Low-Lo
776   368640  245760  368640  245760  614400  368640
Chan  Med Low TB-neg Qos_Exc  Med_Xof  Low_Xof  Qdrops(H-M-L)  Pos  Qlen(Hi-Med-lo) Fl
Tgl_cnt Rdy_sts
776   0 0 0 0 0 0 0 0 0 0 Y 0 0 0 0
0 ff
Chan  Rate  Neg  Pos  LastTS  CurrCr  Pos  [PLC Rate Neg Pos]
776  10485750 65535 65535 116199669 268431360 Y [MM 86 128 1114][EM 87 128 6204][TR 2
9 3102]
DSPHY Info:
Local rf port 0 , rf chan 158 pic loss 123
non short CWS: = 235681130, shorts = 0, stuff bytes = 235639172 bch 235681130
NCP msgs: = 453809753, PLC encodings = 16902476
flow0 rcv 70203 flow1 rcv 3 flow0 drops 0 flow1 drops 0

```

## Configuration Examples

This section provides examples for configuring the OFDM channel.

### Example1: Configuring OFDM Channel



**Note** The OFDM modulation profile must be configured before the OFDM channel profile which references it.

The following example shows how to configure the OFDM channel:

```

enable
configure terminal
cable downstream ofdm-modulation-profile 9
description 512-1k-4k
subcarrier-spacing 50KHz
width 96000000
start-frequency 627000000
assign modulation-default 512-QAM
assign modulation 1024-QAM range-subcarriers freq-abs 635000000 width 74050000
assign modulation 4096-QAM range-subcarriers freq-abs 629000000 width 6000000
exit
configure terminal
cable downstream ofdm-chan-profile 20
description Data profiles: 2 single mod, 1 mixed mod
cyclic-prefix 192
interleaver-depth 16
pilot-scaling 48
roll-off 128
subcarrier-spacing 50KHz
profile-ncp modulation-default 16-QAM

```

```

profile-control modulation-default 256-QAM
profile-data 1 modulation-default 1024-QAM
profile-data 2 modulation-default 2048-QAM
profile-data 3 modulation-profile 9
exit
configure terminal
controller integrated-cable 3/0/0
max-ofdm-spectrum 96000000
ofdm-freq-excl-band start-frequency 683000000 width 10000000
rf-chan 158
power-adjust 0
docsis-channel-id 159
ofdm channel-profile 20 start-frequency 627000000 width 96000000 plc 663000000

```

### Example 2: Configuring OFDM Primary Channel in the MAC Domain

```

enable
configure terminal
Enter configuration commands, one per line. End with CNTL/Z.
interface cable 3/0/0
downstream Integrated-Cable 3/0/3 rf-channel 158
end

```

## Additional References

### Related Document

| Document Title                                                                   | Link                                                                                                                                                                                                      |
|----------------------------------------------------------------------------------|-----------------------------------------------------------------------------------------------------------------------------------------------------------------------------------------------------------|
| Cisco cBR Converged Broadband Routers Layer 2 and DOCSIS 3.0 Configuration Guide | <a href="http://www.cisco.com/c/en/us/td/docs/cable/cbr/configuration/guide/b_cbr_layer2_docsis30.html">http://www.cisco.com/c/en/us/td/docs/cable/cbr/configuration/guide/b_cbr_layer2_docsis30.html</a> |

### MIBs

| MIBs          | MIBs Link                                                                                                                                                                                                              |
|---------------|------------------------------------------------------------------------------------------------------------------------------------------------------------------------------------------------------------------------|
| DOCS-IF31-MIB | To locate and download MIBs for selected platforms, Cisco IOS releases, and feature sets, use Cisco MIB Locator found at the following URL:<br><a href="http://www.cisco.com/go/mibs">http://www.cisco.com/go/mibs</a> |

**Technical Assistance**

| Description                                                                                                                                                                                                                                                                                                                                                                                                                                                                                                                                                             | Link                                                                    |
|-------------------------------------------------------------------------------------------------------------------------------------------------------------------------------------------------------------------------------------------------------------------------------------------------------------------------------------------------------------------------------------------------------------------------------------------------------------------------------------------------------------------------------------------------------------------------|-------------------------------------------------------------------------|
| <p>The Cisco Support website provides extensive online resources, including documentation and tools for troubleshooting and resolving technical issues with Cisco products and technologies.</p> <p>To receive security and technical information about your products, you can subscribe to various services, such as the Product Alert Tool (accessed from Field Notices), the Cisco Technical Services Newsletter, and Really Simple Syndication (RSS) Feeds.</p> <p>Access to most tools on the Cisco Support website requires a Cisco.com user ID and password.</p> | <a href="http://www.cisco.com/support">http://www.cisco.com/support</a> |

## Feature Information for DOCSIS 3.1 OFDM Channel Configuration

Use Cisco Feature Navigator to find information about the platform support and software image support. Cisco Feature Navigator enables you to determine which software images support a specific software release, feature set, or platform. To access Cisco Feature Navigator, go to the <https://cfmg.cisco.com/> link. An account on the Cisco.com page is not required.



**Note** The following table lists the software release in which a given feature is introduced. Unless noted otherwise, subsequent releases of that software release train also support that feature.

**Table 116: Feature Information for DOCSIS 3.1 OFDM Channel Configuration**

| Feature Name                                                      | Releases                      | Feature Information                                                              |
|-------------------------------------------------------------------|-------------------------------|----------------------------------------------------------------------------------|
| DOCSIS 3.1 OFDM Channel Support                                   | Cisco IOS XE Fuji 16.7.1      | This feature was integrated on the Cisco cBR Series Converged Broadband Routers. |
| Full Spectrum 108-1218 MHz Support                                | Cisco IOS XE Fuji 16.7.1      | This feature was integrated on the Cisco cBR Series Converged Broadband Routers. |
| DOCSIS 3.1 OFDM Primary Channel Support                           | Cisco IOS XE Fuji 16.7.1      | This feature was integrated on the Cisco cBR Series Converged Broadband Routers. |
| Enhanced support for subcarrier spacing, exclusion band, and LCPR | Cisco IOS XE Fuji 16.7.1      | This feature was integrated on the Cisco cBR Series Converged Broadband Routers. |
| Hitless OFDM Profile Changes                                      | Cisco IOS XE Everest 16.12.1x | This feature was integrated on the Cisco cBR Series Converged Broadband Routers. |
| Ephemeral Profile to Cable Modem Assignment                       | Cisco IOS XE Everest 16.12.1x | This feature was integrated on the Cisco cBR Series Converged Broadband Routers. |
| Profile Management Application Scaling                            | Cisco IOS XE Everest 16.12.1z | This feature was integrated on the Cisco cBR Series Converged Broadband Routers. |





## CHAPTER 35

# OFDM Channel Power Profile

---

The OFDM Channel Power Profile feature helps in adjusting the power-level of 6 MHz bands in a DOCSIS 3.1 downstream OFDM channel.

Your software release may not support all the features that are documented in this module. For the latest feature information and caveats, see the release notes for your platform and software release. The Feature Information Table at the end of this document provides information about the documented features and lists the releases in which each feature is supported.

Use Cisco Feature Navigator to find information about platform support and Cisco software image support. To access Cisco Feature Navigator, go to <http://tools.cisco.com/ITDIT/CFN/>. An account on <http://www.cisco.com/> is not required.

- [Hardware Compatibility Matrix for the Cisco cBR Series Routers, on page 611](#)
- [Information About OFDM Channel Power Profile, on page 613](#)
- [How to Configure the OFDM Channel Power Profile, on page 614](#)
- [Configuration Example for OFDM Power Profile, on page 615](#)
- [Feature Information for OFDM Channel Power Profile, on page 616](#)

## Hardware Compatibility Matrix for the Cisco cBR Series Routers



---

**Note** The hardware components that are introduced in a given Cisco IOS-XE Release are supported in all subsequent releases unless otherwise specified.

---

Table 117: Hardware Compatibility Matrix for the Cisco cBR Series Routers

| Cisco CMTS Platform                    | Processor Engine                                                                                                                                                                                  | Interface Cards                                                                                                                                                                                                                                                                                                                                                                                                                                                                                                                                                                                                                                                                                                                                                                                 |
|----------------------------------------|---------------------------------------------------------------------------------------------------------------------------------------------------------------------------------------------------|-------------------------------------------------------------------------------------------------------------------------------------------------------------------------------------------------------------------------------------------------------------------------------------------------------------------------------------------------------------------------------------------------------------------------------------------------------------------------------------------------------------------------------------------------------------------------------------------------------------------------------------------------------------------------------------------------------------------------------------------------------------------------------------------------|
| Cisco cBR-8 Converged Broadband Router | <p><b>Cisco IOS-XE Release 16.5.1 and Later Releases</b></p> <p>Cisco cBR-8 Supervisor:</p> <ul style="list-style-type: none"> <li>• PID—CBR-SUP-250G</li> <li>• PID—CBR-CCAP-SUP-160G</li> </ul> | <p><b>Cisco IOS-XE Release 16.5.1 and Later Releases</b></p> <p>Cisco cBR-8 CCAP Line Cards:</p> <ul style="list-style-type: none"> <li>• PID—CBR-LC-8D30-16U30</li> <li>• PID—CBR-LC-8D31-16U30</li> <li>• PID—CBR-RF-PIC</li> <li>• PID—CBR-RF-PROT-PIC</li> <li>• PID—CBR-CCAP-LC-40G</li> <li>• PID—CBR-CCAP-LC-40G-R</li> <li>• PID—CBR-CCAP-LC-G2-R</li> <li>• PID—CBR-SUP-8X10G-PIC</li> <li>• PID—CBR-2X100G-PIC</li> </ul> <p>Digital PICs:</p> <ul style="list-style-type: none"> <li>• PID—CBR-DPIC-8X10G</li> <li>• PID—CBR-DPIC-2X100G</li> </ul> <p>Cisco cBR-8 Downstream PHY Module:</p> <ul style="list-style-type: none"> <li>• PID—CBR-D31-DS-MOD</li> </ul> <p>Cisco cBR-8 Upstream PHY Modules:</p> <ul style="list-style-type: none"> <li>• PID—CBR-D31-US-MOD</li> </ul> |



**Note** Do not use DPICs (8X10G and 2x100G) to forward IP traffic, as it may cause buffer exhaustion, leading to line card reload.

The only allowed traffic on a DPIC interface is DEPI, UEPI, and GCP traffic from the Cisco cBR-8 router to Remote PHY devices. Other traffic such as DHCP, SSH, and UTSC should flow via another router, since DPICs cannot be used for normal routing.



## Information About OFDM Channel Power Profile

The OFDM power profile provides a better, consistent power-level output at the cable modem, compensating the power levels at a finer granularity. It reduces the differing amounts of cable-loss over the bandwidth of OFDM channel.

This feature enables the Cisco cBR Series Converged Broadband Router to correct the transmission loss due to the cable in the plant.

The OFDM power profile (`ofdm-power-profile`) adjusts the transmission power level of each 6 MHz in an OFDM channel. The OFDM channel width can range from 24 MHz to 192 MHz, resulting in band-counts between 4 and 32 for the profile.

Each 6 MHz band is referenced by a band index (`band-index`) that is zero-based, with a maximum band range of 192 MHz OFDM channel being 0 to 31. Each band within the OFDM channel can have a unique power level setting. The OFDM power profile allows a total band adjustment range of 8 dB. Under some specific conditions, if the OFDM channel's downstream controller's base channel power is set to exceed the maximum DRFI specification power level, the OFDM power profile adjustment range can become as high as 9 dB.

In a power profile, you can set the power level (`power-adjust-default`) to a default value. This default value is applied to any band that is not configured through any other means.

You can configure band power levels in two methods: through the power tilt config (`power-tilt-linear`) or by configuring the power level for a band or range of bands (`band-index`). You can use both methods for configuring the band power levels simultaneously within an OFDM power profile.

The power tilt configuration applies a linear power-adjust value between the `power-adjust-default` value applied to the band index 0, and the `power-tilt-linear` adjust value applied to the highest band index of the profile. For example, an OFDM Power Profile of 96 MHz, with a `power-tilt-linear` of 4 dB, and `power-adjust-default` of 0 dB, has 16 bands numbered 0 to 15, band index 0 is +0 dB, band index 15 is +4 dB, and bands 1 to 14 contain the linear power level setting based on the slope of the line between the band 0 and band 15 to the nearest 1/10th dB.

The `band-index` configuration applies a specified value to the indicated bands. The `band-index` configuration can specify a single band or a range of bands. A `power-adjust` configuration is used to specify the power level for the bands to the nearest 1/10th dB.

You can simultaneously use both power tilt and band index, where `band-index` is applied last. When you use both, the `power-tilt-linear` values can be overridden using the `band-index` `power-adjust` values.

A maximum of 64 OFDM power profiles can be configured on the Cisco cBR routers, numbered from 1 to 64. You can apply a single OFDM power profile to multiple controller OFDM channels, across line cards, as long as all validity checks pass during configuration. The router console displays an error message explaining any configuration errors or warnings.

## Restrictions for Configuring OFDM Power Profile

The following restrictions are applicable for configuring an OFDM power profile:

- OFDM power profile can be configured only on DOCSIS 3.1 system
- The power profile can be applied only to downstream controller OFDM channels (RF-channels 158 to 162)

# How to Configure the OFDM Channel Power Profile

## Configuring OFDM Power Profile Using Band-index

Use the following commands along with the band-index configuration to configure OFDM Power Profile, where the band-index values act as an override.

```
enable
configure terminal
cable downstream ofdm-power-profile <profile_id>
  power-adjust-default -2.1
  band-index 0 7
    power-adjust -1.0
  band-index 8 15
    power-adjust -0.5
  band-index 16 23
    power-adjust 0.5
  band-index 24 31
    power-adjust 1.5

controller Integrated-Cable {slot}/{subslot}/{port}
rf-channel {158 - 162 }
power-profile {ofdm-power-profile-id}
```

## Verifying the Power Profile Configuration

To display the power profile configuration details, use the **show cable ofdm-power-profile** command as given in the following example. This command also displays the actual power-band power levels as set by the profile.

```
Router> show cable ofdm-power-profile 3
OFDM Power Profile 3

Power-Adjust-Default(*): -2.1

Power-Band:
[00-07]  -1.0  -1.0  -1.0  -1.0  -1.0  -1.0  -1.0  -1.0  -1.0
[08-15]  -0.5  -0.5  -0.5  -0.5  -0.5  -0.5  -0.5  -0.5  -0.5
[16-23]   0.5   0.5   0.5   0.5   0.5   0.5   0.5   0.5   0.5
[24-31]   1.5   1.5   1.5   1.5   1.5   1.5   1.5   1.5   1.5

+4 .0 |
      |
+3 .0 |
      |
+2 .0 |
      |
+1 .0 |
      |
+0 .0 |-----* * * * *
      |
-1 .0 | * * * * *
      |
-2 .0 |
      |
-3 .0 |
      |
(dB)  | 0 0 0 0 0 0 0 0 0 1 1 1 1 1 1 1 1 2 2 2 2 2 2 2 2 3 3
```

```
0 1 2 3 4 5 6 7 8 9 0 1 2 3 4 5 6 7 8 9 0 1 2 3 4 5 6 7 8 9 0 1
band-index
```

## Configuring OFDM Power Profile with Linear Power-tilt

Use the following commands to configure the OFDM power profile with a linear power-tilt and the band-index override.

```
enable
configure terminal
cable downstream ofdm-power-profile <profile_id>
  power-adjust-default 0.0
  power-tilt-linear 3.5
  band-index 0
  power-adjust 4.0
```

## Verifying the Power Profile Using show controller Command

Use the **show controller** command to display the absolute power-band levels as set by the power profile. When the power-profile is applied to the controller, the power level displayed is the actual transmit power level in dBmV.

```
Router>show controller Integrated-Cable 3/0/0 rf-channel 158 verbose
Chan State Admin Mod-Type Start Width PLC Profile-ID dclid power output
Frequency
 158 UP UP OFDM 849000000 96000000 856000000 20 159 33.0
NORMAL
Resource status: OK
License: granted <09:23:14 EDT Aug 1 2016>
OFDM channel license spectrum width: 92200000
OFDM config state: Configured

OFDM Power Profile: 3
Power-Band:
[00-07] 32.0 32.0 32.0 32.0 32.0 32.0 32.0 32.0
[08-15] 32.5 32.5 32.5 32.5 32.5 32.5 32.5 32.5
[16-23] 33.5 33.5 33.5 33.5 33.5 33.5 33.5 33.5
[24-31] 34.5 34.5 34.5 34.5 34.5 34.5 34.5 34.5

OFDM channel details: [3/0/0:158]
-----
```

## Configuration Example for OFDM Power Profile

This section provides example for the OFDM Power Profile configuration.

### Example: OFDM Power Profile with Linear Power-tilt Configuration

```
enable
configure terminal
cable downstream ofdm-power-profile 3
  power-adjust-default 0.0
  power-tilt-linear 3.5
  band-index 0
  power-adjust 4.0
```

## Feature Information for OFDM Channel Power Profile

Use Cisco Feature Navigator to find information about the platform support and software image support. Cisco Feature Navigator enables you to determine which software images support a specific software release, feature set, or platform. To access Cisco Feature Navigator, go to the <https://cfng.cisco.com/> link. An account on the Cisco.com page is not required.



**Note** The following table lists the software release in which a given feature is introduced. Unless noted otherwise, subsequent releases of that software release train also support that feature.

**Table 118: Feature Information for OFDM Channel Power Profile**

| Feature Name               | Releases                 | Feature Information                                                                |
|----------------------------|--------------------------|------------------------------------------------------------------------------------|
| OFDM Channel Power Profile | Cisco IOS XE Fuji 16.7.1 | This feature was integrated into the Cisco cBR Series Converged Broadband Routers. |



## CHAPTER 36

# DOCSIS 3.1 Path Selection

---

This document describes how to configure the path selection on the Cisco cBR Series Converged Broadband Router.

- [Information about Path Selection, on page 617](#)
- [How to Configure Path Selection, on page 617](#)
- [Additional References, on page 621](#)
- [Feature Information for DOCSIS 3.1 Path Selection, on page 621](#)

## Information about Path Selection

DOCSIS 3.1 Path Selection feature is enhanced to support OFDM downstream channels and OFDMA upstream channels. The RCC selection process is enhanced to include OFDM channels. The TCC selection process is enhanced to include OFDMA channels.

## How to Configure Path Selection

### Configuring Downstream Bonding Group with OFDM Channel

To configure the downstream bonding group with OFDM channel, follow the steps below:

```
enable
configure terminal
interface wideband-cable slot/subslot/bay:wideband-channel
description text
cable bundle id
cable rf-channels channel-list group-list bandwidth-percent percentage-bandwidth
```



---

**Note** Channel 158 to 162 are specified as OFDM channel.

---

## Verifying Downstream Bonding Group with OFDM Channel Configuration

To display the details of the downstream bonding group with OFDM channel, use the **show running-config interface** command as shown in the example below:

```
Router# show running-config interface wideband-cable 3/0/0:13

Building configuration...

Current configuration : 212 bytes
!
interface Wideband-Cable3/0/0:13
 description D31-DSBG: 1 SC-QAM plus 1 OFDM
 cable bundle 1
 cable rf-channels channel-list 8 bandwidth-percent 30
 cable rf-channels channel-list 158 bandwidth-percent 25
end
```

## Configuring Upstream Bonding Group with OFDMA Channel

To configure the upstream bonding group with OFDMA channel, follow the steps below:

```
enable
configure terminal
interface cable slot/subslot/bay
cable upstream bonding-group id
upstream id
```

## Verifying Upstream Bonding Group with OFDMA Channel Configuration

To display the details of the upstream bonding group with OFDMA channel, use the **show running-config interface** command as shown in the example below:

```
Router# show running-config interface cable 6/0/3
Building configuration...

Current configuration : 212 bytes
!
interface Cable6/0/3
 load-interval 30
 downstream Integrated-Cable 6/0/1 rf-channel 158
 upstream 0 Upstream-Cable 1/0/0 us-channel 0
 upstream 1 Upstream-Cable 1/0/0 us-channel 1
 upstream 2 Upstream-Cable 1/0/0 us-channel 2
 upstream 3 Upstream-Cable 1/0/0 us-channel 3
 upstream 6 Upstream-Cable 1/0/0 us-channel 12
 cable upstream balance-scheduling
 cable upstream bonding-group 2
   upstream 0
   upstream 1
   upstream 2
   upstream 3
   upstream 6
 attributes 80000000
 cable bundle 1
 cable privacy accept-self-signed-certificate
!
```

## Verifying the Path Selection Status

To display the path selection status of a cable modem, use the **show cable modem path-sel** command as shown in the example below:

```
router#show cable modem 38c8.5cfe.efa6 path-sel

CM 38c8.5cfe.efa6 Path-Sel Info: 07:20

RCS Filter Result: Succeed
Candidate RCS List: 2
  RCC-Id  Owner-Id  Preliminary  RCP      TLV-56  LBG      SF-Attr  CM-Attr
  1       1 :12289  Pass        Pass     --      Pass     Pass     Pass
  2       1 :12290  Pass        Pass     --      Pass     Pass     Pass

TCS Filter Result: Succeed
TCS Info:
  TCS in CGD           : 0x7          UCID: 1 2 3
  TCS in Freq Range    : 0x7          UCID: 1 2 3
  TCS Impaired         : 0x0

TCS Passed filters:
  Preliminary          : 0x7          UCID: 1 2 3
  LB Group              : 0x7          UCID: 1 2 3
  SF Attr Mask         : 0x7          UCID: 1 2 3
  CM Attr Mask         : 0x7          UCID: 1 2 3

Candidate US-BG List: 4
  UBG-Id  Chan-Mask  Preliminary  TLV-56  LBG      SF-Attr  CM-Attr
  1       0x7        Pass        --      Pass     Pass     Pass
  65537   0x2        Pass        --      Pass     Pass     Pass
  65538   0x4        Pass        --      Pass     Pass     Pass
  65536   0x1        Pass        --      Pass     Pass     Pass

Primary DS Chan Result: Skipped
Candidate Primary DS Chan List: 0

Primary US Chan Result: Skipped
Candidate Primary US Chan List: 0
```

## Clearing the Path Selection Status

To clear the path selection status for all CMs, use the **clear cable modem all path-sel** command as shown in the example below:

```
Router# clear cable modem all path-sel

Router# show cable modem c8fb.26a6.c46a path-sel

CM c8fb.26a6.c46a Path-Sel Info: N/A
Path-Sel status has been cleared after register online.
```

## Verifying the RCC Configuration

To verify the runtime RCCs on a cable interface, use the **show cable mac-domain rcc** command as shown in the example below:

```
Router# show cable mac-domain cable 7/0/0 rcc
```

| RCC-ID | RCP            | RCs | MD-DS-SG | CMs | WB/RCC-TMPL    | D3.0 | D3.1 |
|--------|----------------|-----|----------|-----|----------------|------|------|
| 4      | 00 00 00 00 00 | 16  | 0        | 1   | WB (Wi7/0/0:0) | Y    | Y    |
| 5      | 00 00 00 00 00 | 25  | 0        | 2   | WB (Wi7/0/0:1) | N    | Y    |
| 6      | 00 10 00 00 08 | 8   | 0        | 0   | RCC-TMPL (3:1) | Y    | N    |
| 7      | 00 00 00 00 00 | 4   | 0        | 0   | WB (Wi7/0/0:4) | Y    | Y    |

To display the detailed information for only DOCSIS 3.1 capable RCC, use the **show cable mac-domain rcc simplified** command as shown in the example below:

```
router#show cable mac-domain cable 7/0/0 rcc 5 simplified
```

```
RCC ID           : 5
Created Via      : Wideband - Wi7/0/0:1
CM attribute mask : 0x80000000
```

Primary Receive Channel List:

| Chan Idx | RF Chan   | DCID | Freq      |
|----------|-----------|------|-----------|
| 1        | In7/0/0:0 | 1    | 453000000 |

Non-Primary Receive Channel List:

| Chan Idx | RF Chan     | DCID | Freq      |
|----------|-------------|------|-----------|
| 2        | In7/0/0:1   | 2    | 459000000 |
| 3        | In7/0/0:2   | 3    | 465000000 |
| 4        | In7/0/0:3   | 4    | 471000000 |
| 5        | In7/0/0:4   | 5    | 477000000 |
| 6        | In7/0/0:5   | 6    | 483000000 |
| 7        | In7/0/0:6   | 7    | 489000000 |
| 8        | In7/0/0:7   | 8    | 495000000 |
| 9        | In7/0/0:8   | 9    | 501000000 |
| 10       | In7/0/0:9   | 10   | 507000000 |
| 11       | In7/0/0:10  | 11   | 513000000 |
| 12       | In7/0/0:11  | 12   | 519000000 |
| 13       | In7/0/0:12  | 13   | 525000000 |
| 14       | In7/0/0:13  | 14   | 531000000 |
| 15       | In7/0/0:14  | 15   | 537000000 |
| 16       | In7/0/0:15  | 16   | 543000000 |
| 17       | In7/0/0:16  | 17   | 549000000 |
| 18       | In7/0/0:17  | 18   | 555000000 |
| 19       | In7/0/0:18  | 19   | 561000000 |
| 20       | In7/0/0:19  | 20   | 567000000 |
| 21       | In7/0/0:20  | 21   | 573000000 |
| 22       | In7/0/0:21  | 22   | 579000000 |
| 23       | In7/0/0:22  | 23   | 585000000 |
| 24       | In7/0/0:23  | 24   | 591000000 |
| 25       | In7/0/0:158 | 159  | 663000000 |

OFDM Receive Channel List:

| Chan Idx | RF Chan     | DCID | PLC-Freq  | Profiles |
|----------|-------------|------|-----------|----------|
| 25       | In7/0/0:158 | 159  | 663000000 | 0 1 2    |



## Additional References

### Related Document

| Document Title                                                                   | Link                                                                                                                                                                                                      |
|----------------------------------------------------------------------------------|-----------------------------------------------------------------------------------------------------------------------------------------------------------------------------------------------------------|
| Cisco cBR Converged Broadband Routers Layer 2 and DOCSIS 3.0 Configuration Guide | <a href="http://www.cisco.com/c/en/us/td/docs/cable/cbr/configuration/guide/b_cbr_layer2_docsis30.html">http://www.cisco.com/c/en/us/td/docs/cable/cbr/configuration/guide/b_cbr_layer2_docsis30.html</a> |

### MIBs

| MIBs          | MIBs Link                                                                                                                                                                                                              |
|---------------|------------------------------------------------------------------------------------------------------------------------------------------------------------------------------------------------------------------------|
| • DOCSIF3-MIB | To locate and download MIBs for selected platforms, Cisco IOS releases, and feature sets, use Cisco MIB Locator found at the following URL:<br><a href="http://www.cisco.com/go/mibs">http://www.cisco.com/go/mibs</a> |

### Technical Assistance

| Description                                                                                                                                                                                                                                                                                                                                                                                                                                                                                                                                                             | Link                                                                    |
|-------------------------------------------------------------------------------------------------------------------------------------------------------------------------------------------------------------------------------------------------------------------------------------------------------------------------------------------------------------------------------------------------------------------------------------------------------------------------------------------------------------------------------------------------------------------------|-------------------------------------------------------------------------|
| <p>The Cisco Support website provides extensive online resources, including documentation and tools for troubleshooting and resolving technical issues with Cisco products and technologies.</p> <p>To receive security and technical information about your products, you can subscribe to various services, such as the Product Alert Tool (accessed from Field Notices), the Cisco Technical Services Newsletter, and Really Simple Syndication (RSS) Feeds.</p> <p>Access to most tools on the Cisco Support website requires a Cisco.com user ID and password.</p> | <a href="http://www.cisco.com/support">http://www.cisco.com/support</a> |

## Feature Information for DOCSIS 3.1 Path Selection

Use Cisco Feature Navigator to find information about the platform support and software image support. Cisco Feature Navigator enables you to determine which software images support a specific software release, feature set, or platform. To access Cisco Feature Navigator, go to the <https://cfng.cisco.com/> link. An account on the Cisco.com page is not required.



**Note** The following table lists the software release in which a given feature is introduced. Unless noted otherwise, subsequent releases of that software release train also support that feature.

**Table 119: Feature Information for DOCSIS 3.1 Path Selection**

| Feature Name                       | Releases                 | Feature Information                                                              |
|------------------------------------|--------------------------|----------------------------------------------------------------------------------|
| DOCSIS 3.1 Path Selection          | Cisco IOS XE Fuji 16.7.1 | This feature was integrated on the Cisco cBR Series Converged Broadband Routers. |
| DOCSIS 3.1 Upstream Path Selection | Cisco IOS XE Fuji 16.7.1 | This feature was integrated on the Cisco cBR Series Converged Broadband Routers. |



## CHAPTER 37

# DOCSIS 3.1 Downstream Profile Selection

---

**First Published:** July 13, 2016

DOCSIS 3.1 introduces the concept of downstream profiles for OFDM channels.

### Contents

- [Hardware Compatibility Matrix for the Cisco cBR Series Routers, on page 623](#)
- [Information about Downstream Profiles, on page 625](#)
- [How to Configure Profiles, on page 631](#)
- [Additional References, on page 639](#)
- [Feature Information for Downstream Profile Selection, on page 639](#)

## Hardware Compatibility Matrix for the Cisco cBR Series Routers



---

**Note** The hardware components that are introduced in a given Cisco IOS-XE Release are supported in all subsequent releases unless otherwise specified.

---

Table 120: Hardware Compatibility Matrix for the Cisco cBR Series Routers

| Cisco CMTS Platform                    | Processor Engine                                                                                                                                                                                  | Interface Cards                                                                                                                                                                                                                                                                                                                                                                                                                                                                                                                                                                                                                                                                                                                                                                                 |
|----------------------------------------|---------------------------------------------------------------------------------------------------------------------------------------------------------------------------------------------------|-------------------------------------------------------------------------------------------------------------------------------------------------------------------------------------------------------------------------------------------------------------------------------------------------------------------------------------------------------------------------------------------------------------------------------------------------------------------------------------------------------------------------------------------------------------------------------------------------------------------------------------------------------------------------------------------------------------------------------------------------------------------------------------------------|
| Cisco cBR-8 Converged Broadband Router | <p><b>Cisco IOS-XE Release 16.5.1 and Later Releases</b></p> <p>Cisco cBR-8 Supervisor:</p> <ul style="list-style-type: none"> <li>• PID—CBR-SUP-250G</li> <li>• PID—CBR-CCAP-SUP-160G</li> </ul> | <p><b>Cisco IOS-XE Release 16.5.1 and Later Releases</b></p> <p>Cisco cBR-8 CCAP Line Cards:</p> <ul style="list-style-type: none"> <li>• PID—CBR-LC-8D30-16U30</li> <li>• PID—CBR-LC-8D31-16U30</li> <li>• PID—CBR-RF-PIC</li> <li>• PID—CBR-RF-PROT-PIC</li> <li>• PID—CBR-CCAP-LC-40G</li> <li>• PID—CBR-CCAP-LC-40G-R</li> <li>• PID—CBR-CCAP-LC-G2-R</li> <li>• PID—CBR-SUP-8X10G-PIC</li> <li>• PID—CBR-2X100G-PIC</li> </ul> <p>Digital PICs:</p> <ul style="list-style-type: none"> <li>• PID—CBR-DPIC-8X10G</li> <li>• PID—CBR-DPIC-2X100G</li> </ul> <p>Cisco cBR-8 Downstream PHY Module:</p> <ul style="list-style-type: none"> <li>• PID—CBR-D31-DS-MOD</li> </ul> <p>Cisco cBR-8 Upstream PHY Modules:</p> <ul style="list-style-type: none"> <li>• PID—CBR-D31-US-MOD</li> </ul> |



**Note** Do not use DPICs (8X10G and 2x100G) to forward IP traffic, as it may cause buffer exhaustion, leading to line card reload.

The only allowed traffic on a DPIC interface is DEPI, UEPI, and GCP traffic from the Cisco cBR-8 router to Remote PHY devices. Other traffic such as DHCP, SSH, and UTSC should flow via another router, since DPICs cannot be used for normal routing.

# Information about Downstream Profiles

A profile is a list of modulation orders that are defined for each of the subcarriers within an OFDM channel. The CMTS can define multiple profiles for use in an OFDM channel, where the profiles differ in the modulation orders assigned to each subcarrier. The CMTS can assign different profiles for different groups of CMs.

## Default Data Profile

The first time a CM registers, it is assigned a default data profile. The default data profile is "profile-data 1". If "profile-data 1" is not configured, "profile-control" is assigned to the CM.



---

**Note** Profile A, with profile ID 0, is also referred to as the control profile.

---

## Recommended Profile

Based on the Receive Modulation Error Ratio (RxMER) values collected from a modem, the CMTS finds among the existing profiles the one that may provide the highest speed, and yet at the same time may have sufficient Signal to Noise Ratio (SNR) margin for the modem to receive code words with acceptable error. This profile is called the recommended profile for that CM. The **show cable modem phy ofdm-profile** command displays the recommended profile for each CM. Recommended Profile will take effect when the CM is reset by the operator. When the CM comes back online, recommended profile is assigned to it.

Internal PMA is enabled by default on the cBR-8. If external PMA is enabled, internal PMA is disabled and can be enabled by running the following config command on the cBR-8:

```
no cable downstream ofdm-prof-mgmt prof-upgrade-pma
```

In external PMA, the cBR-8 does not automatically upgrade a CM's profile to the recommended profile. In internal PMA, the profile can be upgraded to the recommended profile in the next OFDM Profile Test (OPT) cycle.

A user configurable age is associated with each recommended profile, which can be configured as follows:

```
Router (config)#cable downstream ofdm-prof-mgmt recommend-profile-age age-in-minutes
```

If the recommended profile exceeds this age, it is no longer valid for that CM.

## Unfit Profile

When a Cable Modem reports an OFDM profile failure (CM-STATUS Event 16 message) for a profile, the OFDM Profile management module on CMTS moves this profile to the **Unfit** profile list. Later, CMTS may remove the same profile from the cable modem by sending a Dynamic Bonding Change Request (DBC-REQ) message.

The profiles remain in the unfit profile list until

- a CM-STATUS Event 24 message is received
- the **unfit-profile-age** timer expires.

You can configure the maximum age that is associated with each unfit profile, using the following command:

```
Router (config)#cable downstream ofdm-prof-mgmt unfit-profile-age age-in-minutes
```

If the unfit profile for a modem exceeds this age, the profile is no longer unfit and cleared from the unfit list.

CMTS device does not clear the profiles from the unfit list while processing a Dynamic Bonding Change Response (DBC-RSP) message received from the cable modem.

Unfit profiles are unusable as long as they are present in the unfit list.

The following example shows the *partial* output of the **show cable modem XXXX.XXXX.XXXX prof-mgmt downstream verbose**.

```
router# show cable modem XXXX.XXXX.XXXX prof-mgmt downstream verbose
.
.
.
DCID                               : 159
Configured Profile(s)              : 0 1 2 3 4 5 6
Profile(s) in REG-RSP-MP           : 0 1 2 3
Profile(s) in DBC-REQ             : N/A
Current profile                     : 1 [4096-QAM]
Percentages of ideal BL vs Curr Prof : 0 (better) 99 (equal)
External Profile Management (PMA)   : Inactive
Downgrade profile                   : 2
Recommend profile                   : 1
Unfit profile(s)                 : N/A
Recommend profile (Expired)         : N/A
Unfit profile(s) (Expired)          : N/A
Flow to Profile override            : Inactive
.
.
.
```

In this output, the DBC-REQ and Unfit profile list is empty as indicated by the lines highlighted in bold.

The following example shows the *partial* output of the **show cable modem XXXX.XXXX.XXXX prof-mgmt downstream verbose** after the CM status event 16 for the current profile **1** is generated.

```
router# show cable modem XXXX.XXXX.XXXX prof-mgmt downstream verbose
.
.
.
DCID                               : 159
Configured Profile(s)              : 0 1 2 3 4 5 6
Profile(s) in REG-RSP-MP           : 0 1 2 3
Profile(s) in DBC-REQ             : N/A
Current profile                     : 2 [2048-QAM]
Percentages of ideal BL vs Curr Prof : 99 (better) 0 (equal)
External Profile Management (PMA)   : Inactive
Downgrade profile                   : 4
Recommend profile                   : 1
Unfit profile(s)                 : 1
Recommend profile (Expired)         : N/A
Unfit profile(s) (Expired)          : N/A
Flow to Profile override            : Inactive
.
.
.
```

In this output, profile **1** moves to the Unfit profile list and profile **2** moves as a current profile. As profile **2** is already on a cable modem so DBC-REQ isn't triggered.

## Implementing Hysteresis Timer for Profile Recovery

**Table 121: Feature History**

| Feature Name                                       | Release Information          | Feature Description                                                                                                                                                                                             |
|----------------------------------------------------|------------------------------|-----------------------------------------------------------------------------------------------------------------------------------------------------------------------------------------------------------------|
| Implementing hysteresis timer for profile recovery | Cisco IOS XE Dublin 17.12.1z | CMTS can implement a hysteresis function or timer for profile recovery starting with this release. This timer uses the OPT process to check RxMER values at the CM before recovery or upgrading to the profile. |

Starting with Cisco IOS XE Dublin 17.12.1z, CMTS can implement a hysteresis function or timer for profile recovery without having to wait for the next regularly scheduled rx-mer poll. To recover a Unfit profile more quickly after the CMTS receives cm-status event 24 (profile recovery) from the CM, the profile recovery has been introduced.

You can control the configuration for the regular RxMER poll timer for profile recovery with the following command:

```
Router (config)#cable downstream ofdm-prof-mgmt rxmer-poll-interval interval
```

The following command is used to set a time from profile recovery to On-Demand RxMER Polling where interval is set in range 10 to 3600 seconds:

```
Router (config)#cable downstream ofdm-prof-mgmt unfit-profile-hysteresis interval
```

The following example shows the output of the **show cable modem mac address prof-mgmt downstream** configuration

```
router# show cable modem 206a.9454.30a4 prof-mgmt downstream
Downstream Profile Management Data:
MAC Address       : 206a.9454.30a4
IP Address        : 9.32.0.43
IPv6 Address      : ---
RxMer Exempt Percent : 2
RxMer Margin qDB  : 0
Automatic Prof Dwngrd : Active
Internal PMA      : Active
Unfit Profile Aging : Active
DCID              : 159
Configured Profile(s) : 0 1 2
Profile(s) in REG-RSP-MP : 0 1 2
Profile(s) in DBC-REQ   : N/A
Current profile       : 0 [1024-QAM]
Percentages of ideal BL vs Curr Prof : 99 (better) 0 (equal)
External Profile Management (PMA) : Inactive
Downgrade profile    : 0
Recommend profile    : 1
Unfit profile(s)     : N/A
Recommend profile (Expired) : N/A
Unfit profile(s) (Expired) : N/A
Flow to Profile override : Inactive
Number of SubCarriers : 4096
1st Active SubCarrier : 1126
# of Active SubCarriers: 1844
Tx Time              : 0h:30m:22s ago (Jun 24 11:57:18.000)
```

```

Rx Time                : 0h:30m:22s ago (Jun 24 11:57:18.000)
OFDM Profile Failure Rx: 0h:14m:48s ago (Jun 24 12:12:52.000)
OFDM Profile Recover Rx: 0h:14m:45s ago (Jun 24 12:12:55.000)
MER Poll Period (min): 60
Recommend Timeout (min): 120
Unfit Timeout (min): 60
Unfit Profile Hysteresis(sec): Disabled
Source                 : OPT
Sub-                   RxMER

```

## Moving OFDM Profiles Out Of Unfit Profile List

There are two ways to move a profile out of the unfit profile list:

- When the CMTS receives a profile-specific **CM-STATUS Event 24** (profile recovery) message from the cable modem, the profile is automatically moved out of the unfit profile list.
- When the **cable downstream ofdm-prof-mgmt unfit-profile-age** *age* timer configuration expires and an OFDM Profile Test (OPT) is successful, the profile is moved out of the unfit profile list.

If you configure this command, a good profile remains in the unfit profile list and wait for the timer to expire. Even if the profile qualifies to be moved out of the unfit list as there is no FEC error, it is still stuck in the unfit list due to this timer.

A cBR-8 router sends a **CM-STATUS Event 24** message to the CMTS to indicate that there is no FEC error for a particular unfit profile and the same profile can be moved out of the unfit list.

### Disabling OFDM Unfit Profile Aging

*Table 122: Feature History*

| Feature Name                       | Release Information          | Feature Description                                                                                                                                                                                                                                                                                                                                                                                                                                                                                                                                                                |
|------------------------------------|------------------------------|------------------------------------------------------------------------------------------------------------------------------------------------------------------------------------------------------------------------------------------------------------------------------------------------------------------------------------------------------------------------------------------------------------------------------------------------------------------------------------------------------------------------------------------------------------------------------------|
| Disabling OFDM Unfit Profile Aging | Cisco IOS XE Dublin 17.12.1z | <p>With this release, you can disable the OFDM unfit profile aging functionality. As a result, a profile automatically moves out of the unfit profile list, only when the CMTS receives a profile-specific <b>CM-STATUS Event 24</b> message from the cable modem.</p> <p>Disabling OFDM Unfit Profile aging allows good profiles to move out of the unfit profile list. Good profiles do not need to wait for the timer to expire to move out of the unfit profile list.</p> <p><b>Command Added:</b> <code>cable downstream ofdm-prof-mgmt unfit-profile-age disable</code>.</p> |

Profiles are eligible to move out of the unfit list when a cBR-8 router sends a **CM-STATUS Event 24** message to the CMTS. However if an unfit profile timer is configured, then the profile remains in the unfit list even though the profile qualifies to be moved out of the unfit as there is no FEC error.

You can completely disable the OFDM unfit profile aging functionality. The profile does not have to wait for a timeout and instead only depends on the CMTS receiving a **CM-STATUS Event 24** message, to move out of the unfit list.



Use the **cable downstream ofdm-prof-mgmt unfit-profile-age disable** command to disable unfit profile aging.

## Clearing OFDM Unfit Profile List

*Table 123: Feature History*

| Feature Name                     | Release Information          | Feature Description                                                                                                                                                                                                                                                                                                                                                                        |
|----------------------------------|------------------------------|--------------------------------------------------------------------------------------------------------------------------------------------------------------------------------------------------------------------------------------------------------------------------------------------------------------------------------------------------------------------------------------------|
| Clearing OFDM Unfit Profile List | Cisco IOS XE Dublin 17.12.1z | CMTS devices clear all the profiles from the unfit profile list upon receiving a Dynamic Bonding Change Response (DBC-RSP) message from the cable modem.. The profiles are cleared as long as they are not present in the Dynamic Bonding Change Request (DBC-REQ) list of Profiles.<br><br>This feature ensures that good profiles do not remain in the unfit list for a longer duration. |

When a cBR-8 router reports an OFDM profile failure (CM-STATUS event 16) for a profile, the OFDM profile management module on CMTS moves the faulty profile to the unfit list.

When CMTS sends a Dynamic Bonding Change Request (DBC-REQ) message to update the list of profiles on the cBR-8 router, the cBR-8 router sends the Dynamic Bonding Change Response (DBC-RSP) message in response. The DBC messages are system defined MAC management messages which handle changing of channel assignments and Downstream Service Identifiers (DSID).

CMTS clears the profiles from the unfit profile list, after receiving a Dynamic Bonding Change Response (DBC-RSP) message as long as they are not present in the list of profiles in Dynamic Bonding Change Request (DBC-REQ) message.

The unfit profile list does not have to meet either of these conditions to be cleared:

- The **unfit-profile-age** timer to expire.
- CMTS receiving a CM-STATUS Event 24 from the cable modem.

Use the **show cable modem [ ip-address | mac-address ] prof-mgmt downstream** command to verify if the **unfit** profile list is clear.

This feature ensures that good profiles don't remain in the unfit list and ensures timely clearing up of the unfit list.

The following example shows the *partial* output of the **show cable modem XXXX.XXXX.XXXX prof-mgmt downstream verbose** after the CM status event 16 for the current profile 2 is generated in releases before Cisco IOS XE Dublin 17.12.1z:

```
router# show cable modem XXXX.XXXX.XXXX prof-mgmt downstream verbose
.
.
.
DCID                               : 159
Configured Profile(s)              : 0 1 2 3 4 5 6
Profile(s) in REG-RSP-MP           : 0 1 2 3
Profile(s) in DBC-REQ             : 0 3 4 5
Current profile                     : 4 [512-QAM..2048-QAM]
Percentages of ideal BL vs Curr Prof : 99 (better) 0 (equal)
```

```

External Profile Management (PMA) : Inactive
Downgrade profile                : 0
Recommend profile                 : 1
unfit profile(s)                 : 1 2
Recommend profile (Expired)       : N/A
unfit profile(s) (Expired)        : N/A
Flow to Profile override          : Inactive
.
.
.

```

In this output, profile **2** moves to the unfit profile list and profile **4** moves to the current profile. As profile **4** isn't on a cable modem, DBC-REQ is triggered. The unfit profile list currently has profiles **1** and **2** and the DBC-REQ list has profiles **0**, **3**, **4** and **5**.

The unfit profiles **1** and **2** in this case remain in the unfit profile list until the unfit timer expires or until CM status event 24 is received from the cable modem. These Profiles can't be used by the cable modem until they are cleared from the unfit profile list.

The following example shows the *partial* output of the **show cable modem XXXX.XXXX.XXXX prof-mgmt downstream verbose** after the CM status event 16 for the current profile **2** is generated in Cisco IOS XE Dublin 17.12.1z and later.

```

router# show cable modem XXXX.XXXX.XXXX prof-mgmt downstream verbose
.
.
.
DCID                               : 159
Configured Profile(s)              : 0 1 2 3 4 5 6
Profile(s) in REG-RSP-MP           : 0 1 2 3
Profile(s) in DBC-REQ             : 0 3 4 5
Current profile                     : 4 [512-QAM..2048-QAM]
Percentages of ideal BL vs Curr Prof : 99 (better) 0 (equal)
External Profile Management (PMA)  : Inactive
Downgrade profile                  : 0
Recommend profile                   : 1
unfit profile(s)                 : N/A
Recommend profile (Expired)         : N/A
unfit profile(s) (Expired)          : N/A
Flow to Profile override            : Inactive
.
.
.

```

In this output, profile **2** moves to the unfit profile list and profile **4** moves to the current profile. As profile **4** isn't on a cable modem, DBC-REQ is triggered. Profile **1** and **2** are cleared from the unfit profile list since profiles **1** and **2** aren't in the DBC-REQ list, so CMTS is able to select those profiles again sometime in the future.

Unlike the previous example, the unfit profile list is clear.

# How to Configure Profiles

## OFDM Profile Downgrade

A cBR-8 router sends a CM-STATUS event 16 message to indicate a downstream OFDM profile failure. When CMTS receives this message, it takes immediate action to downgrade the router to a lower profile, as per the pre-configured profile ordering.

### Events Triggering an OFDM Profile Downgrade

The following table, extracted from [DOCSIS 3.1 MULPI], lists the CM-Status events that trigger a profile downgrade:

**Table 124: Table: CM-Status Events for Profile Downgrade**

| Event Type | Event Condition         | Status Report Events                                                          |                                                                                                                                                                                                                            | Parameters reported by CM |            |
|------------|-------------------------|-------------------------------------------------------------------------------|----------------------------------------------------------------------------------------------------------------------------------------------------------------------------------------------------------------------------|---------------------------|------------|
|            |                         | Trigger event to "on"                                                         | Trigger event to "off"                                                                                                                                                                                                     | DCID                      | Profile ID |
| 16         | DS OFDM profile failure | Loss of FEC lock on one of the assigned downstream OFDM profiles of a channel | Re-establishment of FEC lock for that OFDM profile;<br>OR<br>Removal of the channel from the active channel list in the primary channel MDD;<br>OR<br>Removal of the channel from the CM's Receive Channel set via DBC-REQ | Yes                       | Yes        |

### Configuring Automatic OFDM Profile Downgrade

To configure automatic profile downgrade, use the following command in global configuration mode:

```
Router (config)#cable downstream ofdm-prof-mgmt prof-dwngrd-auto
```

This command is enabled by default.

To disable the automatic profile downgrade, use the following command in global configuration mode:

```
Router (config)#no cable downstream ofdm-prof-mgmt prof-dwngrd-auto
```

For more information see [cable downstream ofdm-prof-mgmt prof-dwngrd-auto](#)

### Viewing the OFDM Profile Downgrade Order

To view information about the profile downgrade ordering on a given OFDM channel in global configuration mode:

```
Router# show controllers integrated-Cable 2/0/3 rf-channel 158 prof-order
```

Here is a sample output of the command:

```
Router# show controllers integrated-Cable 2/0/3 rf-channel 158 prof-order
OFDM channel data profile order: [2/0/3:158]
-----
Data Profile:      Downgrade Profile:
Profile 1         ->   Profile 0
Profile 2         ->   Profile 1
Profile 3         ->   Profile 2
```

For more information see, [show controller integrated-cable](#)

## Types of OFDM Profile Downgrade

There are two types of OFDM profile downgrade:

- Bit Loading Based OFDM Profile Downgrade
- Capacity Based OFDM Profile Downgrade

### Bit Loading Based OFDM Profile Downgrade

When the CMTS must perform a downgrade, the profile is selected based on the RxMER margin. The profile with the next lowest margin is selected. Profiles with an equal or higher margin are not considered even if it is a good profile.

RxMER margin is the measurement in profile selection as part of the profile downgrade. The recommended profile must be a suitable profile, and its required MER should be closest to the actual RxMER. It may not be the suitable profile with the highest rate.

In this illustration, Profile 1 is the in-use profile and we assume a 10% MER margin. Capacity order from high to low is: 1 -> 4 -> 3 -> 2. However, only profile 2 and profile 3 are lower than profile 1 with a 10% MER margin, and profile 3 has a higher rate than profile 2. If the bit loading method is configured, then the downgrade order is: 1 -> 3 -> 2.

Figure 24: RxMER Measurement Against the Required MER

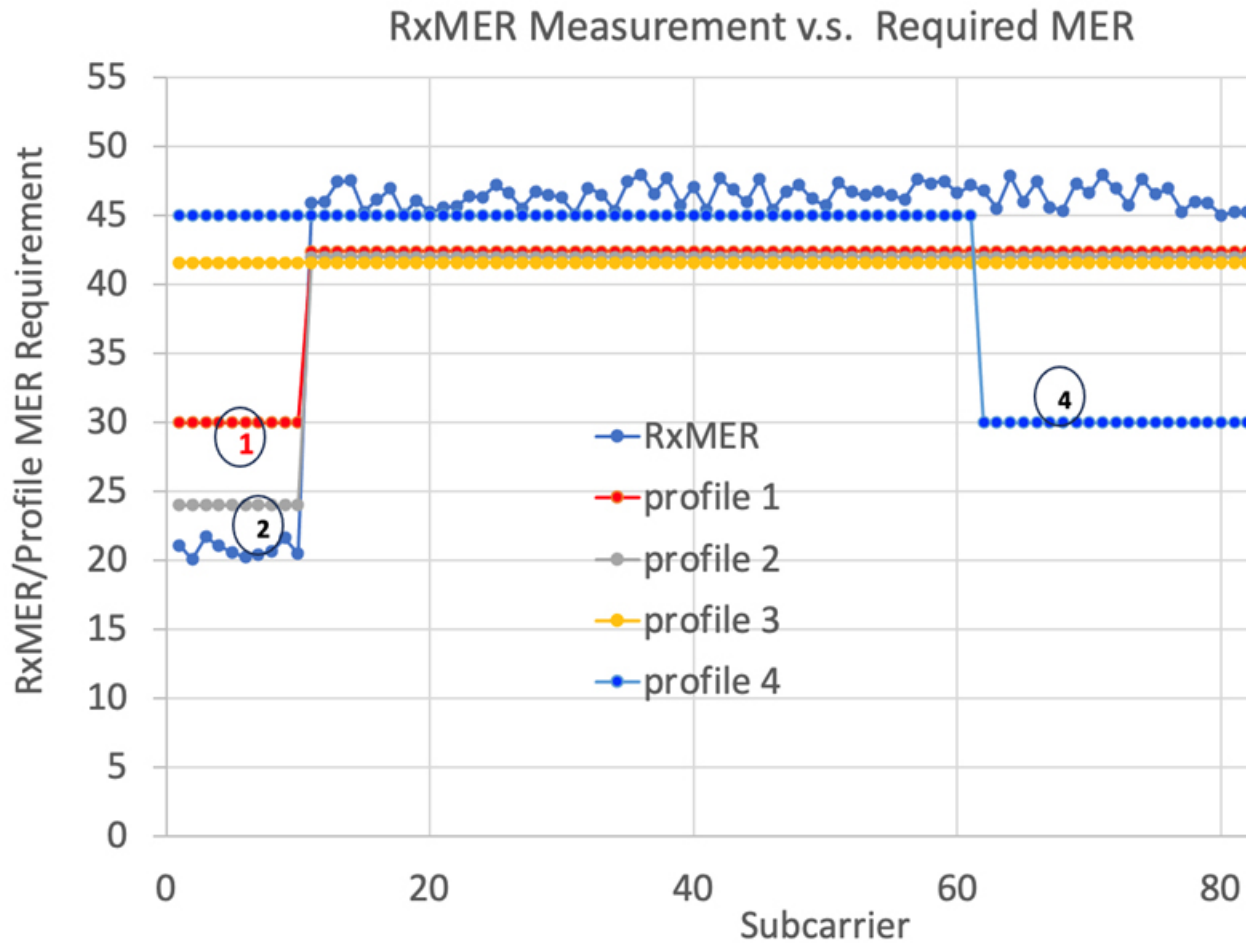

CMTS may eliminate good profiles that the cable modem didn't report as failed (CM-STATUS event 16). This profile could have a higher or equal capacity compared with the selected profile (such as profile 4 in the illustration). It is only skipped because of the rules of the bit loading method.

CMTS also performs a profile downgrade if it receives a CM-STATUS event 16 message for the current in-use profile, when the bit loading method is used.

### Configuring Bit Loading Based OFDM Profile Downgrade

Use the **cable downstream ofdm-prof-mgmt prof-order-method bit-loading** command to enable the bit loading method of downgrading profiles. This command is configured by default.

Also, if you configure the **no cable downstream ofdm-prof-mgmt prof-order-method** command, it enables the default option which is the bit loading method of downgrading profiles.

## Capacity Based OFDM Profile Downgrade

Table 125: Feature History

| Feature Name                      | Release Information          | Feature Description                                                                                                                                                                                                                                                                                                                                                                                                                                                                                                                                                                                                                                 |
|-----------------------------------|------------------------------|-----------------------------------------------------------------------------------------------------------------------------------------------------------------------------------------------------------------------------------------------------------------------------------------------------------------------------------------------------------------------------------------------------------------------------------------------------------------------------------------------------------------------------------------------------------------------------------------------------------------------------------------------------|
| Optimizing OFDM Profile Downgrade | Cisco IOS XE Dublin 17.12.1z | <p>The process of downgrading an OFDM profile to is optimized to ensure that the best available profile is selected. Use the capacity based profile ordering method to ensure that the profile with the highest capacity is selected and a good profile is not skipped. Here, capacity refers to the pre-configured data transfer rate in Kbps for a profile.</p> <p>As part of this feature, CMTS always skips a profile downgrade if CM-STATUS event 16 is not on the current profile, regardless of profile order method configuration.</p> <p><b>Command Added:</b> <code>cable downstream ofdm-prof-mgmt prof-order-method capacity</code></p> |

CMTS selects a profile to downgrade, when a cable modem sends a CM-STATUS event 16 to CMTS, on a profile which is currently used. To ensure that a good profile is not skipped, we have added a capacity-based profile ordering method. Here, capacity refers to the pre-configured data transfer rate in Kbps for a profile. This method selects the downgrade profile only based on the actual capacity. The profile with the highest capacity is selected.

If you configure the **capacity** order method, the downgrade order for this illustration is 1 -> 4 -> 3 -> 2. This time Profile 4 which has the highest capacity is not skipped, and is only considered, as capacity based ordering method is configured.

Figure 25: RxMER Measurement Against the Required MER

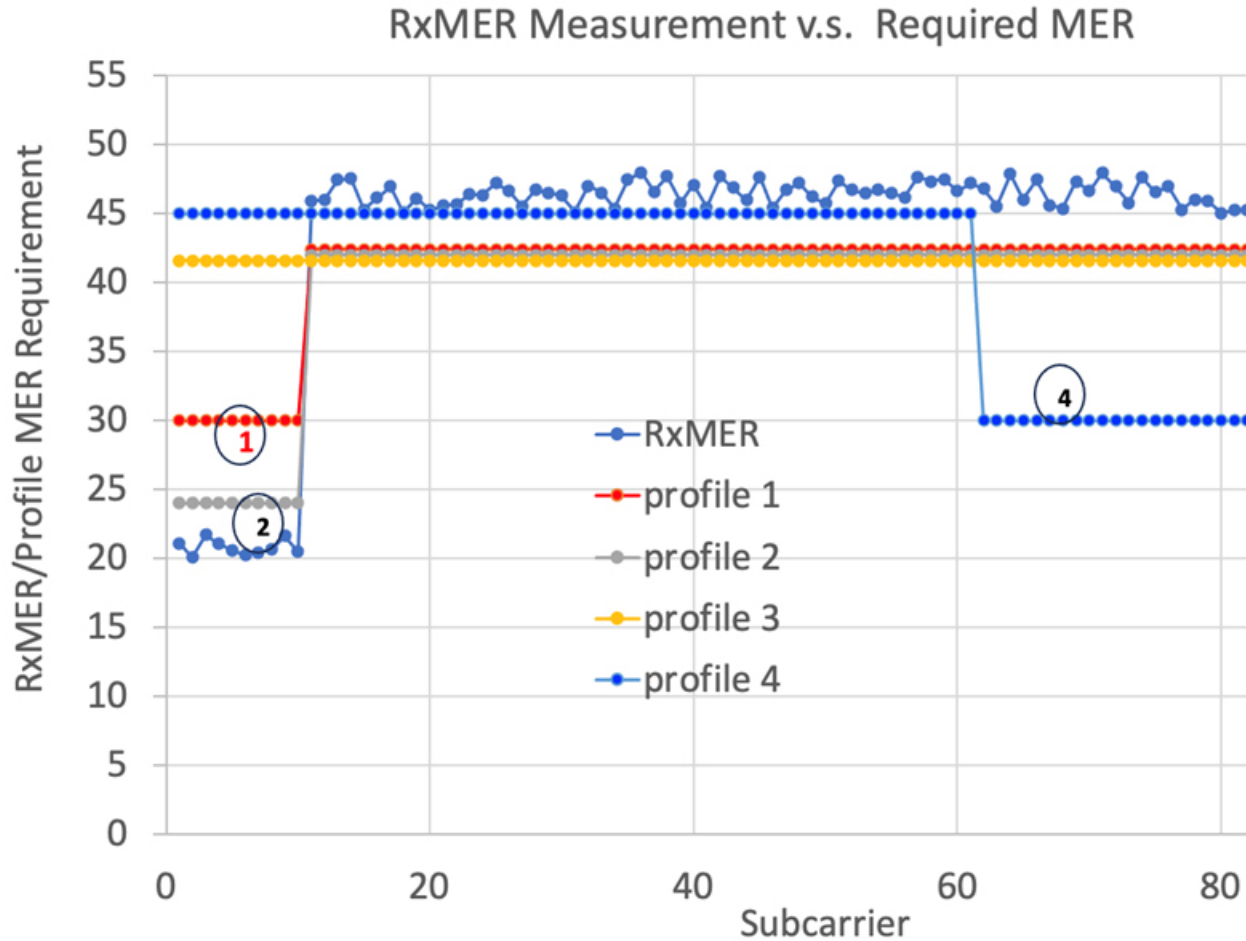

### Configuring Capacity Based OFDM Profile Downgrade Method

Use the **cable downstream ofdm-prof-mgmt prof-order-method capacity** to configure the downgrade of the profile to be based on the capacity. Here is a sample configuration:

```
Router(config)# cable downstream ofdm-prof-mgmt prof-order-method capacity
```

### Verifying OFDM Profile Downgrade Method

To verify the configuration, use the **show controllers downstream-cable slot/subslot/port rf-channel rf-channel prof-order**. Here is a sample output of the command:

```
Router# show controllers downstream-cable 8/0/0 rf-channel 160 prof-order
OFDM channel data profile order: [8/0/0:160]
Ordering method : Capacity
RxMER Subcarrier Difference Tolerance: 2%
-----
Data Profile:           Downgrade Profile:
Profile 1 ->           Profile 2
Profile 2 ->           Profile 3
Profile 3 ->           Profile 4
Profile 4 ->           Profile 0
```

This command output also displays the type of OFDM profile downgrade method. In this case **Ordering method: Capacity** indicates capacity based OFDM profile downgrade method.

## Configuring RxMER to Bit Loading Mapping

There are many ways to map the RxMER values to bit loading values. We use the following mapping recommended in [DOCSIS 3.1 OSSI], as our baseline mapping:

| RxMER (in ¼ DB) | QAM   | Bit Loading |
|-----------------|-------|-------------|
| 60              | 16    | 4           |
| 84              | 64    | 6           |
| 96              | 128   | 7           |
| 108             | 256   | 8           |
| 122             | 512   | 9           |
| 136             | 1024  | 10          |
| 148             | 2048  | 11          |
| 164             | 4096  | 12          |
| 184             | 8192  | 13          |
| 208             | 16384 | 14          |

- To configure a margin to adjust the RxMER to bit loading mapping, use the following command:

```
Router(config)# cable downstream ofdm-prof-mgmt mer-margin-qdb quarter-DB
```

This configured value (*quarter-DB*) is added to the RxMER values collected by CMTS before using the above mapping table, thus giving a user more control in selecting the recommended profiles.

- To specify the percentage of subcarriers that can be ignored in the recommended profile calculation, use the following command:

```
Router(config)# cable downstream ofdm-prof-mgmt exempt-sc-pct percent
```

This provides a way to specify the extent that the outliers can be ignored.

## Hitless OFDM Profile Changes

Cisco cBR supports Hitless OFDM Profile from Cisco IOS XE Everest 16.12.1x, as a Profile Management Application (PMA) tool.

The operation is as follows:

1. PMA determines if the modulation order of a data profile in an OFDM channel can be upgraded or downgraded. This decision is based on the MER data that is received from cable modems that uses the profile.
2. Poll cBR for all modems with active profiles to identify inactive ones.



3. Move modems to a temporary data profile if all are in use. Note that this is not control profile.
4. Delete any unused OFDM profile. The PMA repeats step 2 and step 3 to avoid race conditions.
5. Add (or Delete) a new OFDM profile with the desired modulation order to the OFDM channel.
6. Define the new profile list for the modems (DBC sent to modems by cBR).
7. Move modems to the new profile.

## Ephemeral Profile to Cable Modem Assignment

Cisco cBR supports Ephemeral Profile to Cable Modem Assignment from Cisco IOS XE Everest 16.12.1x, as a Profile Management Application (PMA) tool.

If the modem is not listening to the desired profile, you can submit up to 4 data profiles. The PMA wants to be active for that cable modem before issuing the profile assignment command. The control profile zero (0) is always included by default.

The following commands are supported:

- **cable modem <mac> ofdm-set-profiles chan <n> profiles <profile list>**

This command initiates a DBC to the cable modem with the specified profile list. The profile list order defines the downgrade profile in case the CM-STATUS is 16.

- **cable downstream ofdm-flow-to-profile interface <integrated-Cable x/y/z:n> profile-data <n> mac-address <mac>**

This command enables the CMTS to start forwarding all traffic to the cable modem using the specified profile. Ensure that you use the accompanying **cable modem mac-address mac opt0** command for the changes to take effect immediately.

Move the cable modems traffic to one of the profiles that it is listening to. DBC is not necessary. If the profile is not active on the cable modem, then the CLI reports error. If the CMTS receives a CM-STATUS 16 for that profile, the CMTS downgrades the profile automatically.

The CM-STATUS does not reset when moving to another profile.

## Display the Cable Modem Count per Profile

Feature History

**Table 126: Feature History**

| Feature Name                                | Release Information            | Feature Description                                                                                                                                                                                                                                                                                                                                       |
|---------------------------------------------|--------------------------------|-----------------------------------------------------------------------------------------------------------------------------------------------------------------------------------------------------------------------------------------------------------------------------------------------------------------------------------------------------------|
| Display CM counts per US IUC and DS profile | Cisco IOS XE Bengaluru 17.6.1x | This feature introduces new commands <b>show cable modem phy ofdm downstream prof-count</b> and <b>show cable modem phy ofdm upstream iuc-count</b> , it helps tracking and reporting number of Cable Modems being in use per Upstream IUC and Downstream Profile on each controller separately. These counters are indicative of health of the RF plant. |

To display the CM count per downstream channel and profile, use the **show cable modem phy ofdm downstream prof-count** command as shown in the examples below:

```
Router#show cable modem phy ofdm downstream prof-count
|<----- CM Count per profile
----->|
Channel      IF-INDX  P-0  P-1  P-2  P-3  P-4  P-5  P-6  P-7  P-8  P-9  P-10  P-11  P-12  P-13
P-14 P-15
-----
----
In0/0/0:158  264134   0   0   0   3   0   0   -   -   -   0   -   -   -
-   -   -
In0/0/0:159  264135   0   0   0   3   0   0   -   -   -   0   -   -   -
-   -   -
Do9/0/0:158  321478   1   0   0   0   4   0   -   -   -   0   -   -   -
-   -   -
```

Or use the command in the example below:

```
Router#show controllers downstream-cable 9/0/0 rf-channel 158 prof-status

Profile status:
-----
Control profile: Oper state: UP, Modem count: 1
  Modem list: 4800.33ef.3aea
Data profile 1: Oper state: UP, Modem count: 0
Data profile 2: Oper state: UP, Modem count: 0
Data profile 3: Oper state: UP, Modem count: 0
Data profile 4: Oper state: UP, Modem count: 4
  Modem list: 4800.33ef.06ca 4800.33ef.0d1a 4800.33ea.716a 4800.33ef.3c52

Data profile 5: Oper state: UP, Modem count: 0
```

## Additional References

### Technical Assistance

| Description                                                                                                                                                                                                                                                                                                                                                                                                                                                                                                                                                             | Link                                                                    |
|-------------------------------------------------------------------------------------------------------------------------------------------------------------------------------------------------------------------------------------------------------------------------------------------------------------------------------------------------------------------------------------------------------------------------------------------------------------------------------------------------------------------------------------------------------------------------|-------------------------------------------------------------------------|
| <p>The Cisco Support website provides extensive online resources, including documentation and tools for troubleshooting and resolving technical issues with Cisco products and technologies.</p> <p>To receive security and technical information about your products, you can subscribe to various services, such as the Product Alert Tool (accessed from Field Notices), the Cisco Technical Services Newsletter, and Really Simple Syndication (RSS) Feeds.</p> <p>Access to most tools on the Cisco Support website requires a Cisco.com user ID and password.</p> | <a href="http://www.cisco.com/support">http://www.cisco.com/support</a> |

## Feature Information for Downstream Profile Selection

Use Cisco Feature Navigator to find information about the platform support and software image support. Cisco Feature Navigator enables you to determine which software images support a specific software release, feature set, or platform. To access Cisco Feature Navigator, go to the <https://cfmg.cisco.com/> link. An account on the Cisco.com page is not required.



**Note** The following table lists the software release in which a given feature is introduced. Unless noted otherwise, subsequent releases of that software release train also support that feature.

**Table 127: Feature Information for Downstream Profile Selection**

| Feature Name                 | Releases                    | Feature Information                                                                                               |
|------------------------------|-----------------------------|-------------------------------------------------------------------------------------------------------------------|
| Downstream Profile Selection | Cisco IOS XE Everest 16.6.1 | This feature was integrated into Cisco IOS XE Everest 16.6.1 on the Cisco cBR Series Converged Broadband Routers. |





## CHAPTER 38

# DOCSIS 3.1 Commanded Power for Upstream SC-QAMs

---

This guide describes commanded power for upstream SC-QAMs on the Cisco cBR Router.

- [Hardware Compatibility Matrix for the Cisco cBR Series Routers](#), on page 641
- [Information About Commanded Power Feature for Upstream SC-QAMs](#), on page 643
- [Feature TLVs](#), on page 643
- [Additional References](#), on page 644
- [Feature Information for Commanded Power for US SC-QAMs](#), on page 644

## Hardware Compatibility Matrix for the Cisco cBR Series Routers



---

**Note** The hardware components that are introduced in a given Cisco IOS-XE Release are supported in all subsequent releases unless otherwise specified.

---

Table 128: Hardware Compatibility Matrix for the Cisco cBR Series Routers

| Cisco CMTS Platform                    | Processor Engine                                                                                                                                                                                  | Interface Cards                                                                                                                                                                                                                                                                                                                                                                                                                                                                                                                                                                                                                                                                                                                                                                                 |
|----------------------------------------|---------------------------------------------------------------------------------------------------------------------------------------------------------------------------------------------------|-------------------------------------------------------------------------------------------------------------------------------------------------------------------------------------------------------------------------------------------------------------------------------------------------------------------------------------------------------------------------------------------------------------------------------------------------------------------------------------------------------------------------------------------------------------------------------------------------------------------------------------------------------------------------------------------------------------------------------------------------------------------------------------------------|
| Cisco cBR-8 Converged Broadband Router | <p><b>Cisco IOS-XE Release 16.5.1 and Later Releases</b></p> <p>Cisco cBR-8 Supervisor:</p> <ul style="list-style-type: none"> <li>• PID—CBR-SUP-250G</li> <li>• PID—CBR-CCAP-SUP-160G</li> </ul> | <p><b>Cisco IOS-XE Release 16.5.1 and Later Releases</b></p> <p>Cisco cBR-8 CCAP Line Cards:</p> <ul style="list-style-type: none"> <li>• PID—CBR-LC-8D30-16U30</li> <li>• PID—CBR-LC-8D31-16U30</li> <li>• PID—CBR-RF-PIC</li> <li>• PID—CBR-RF-PROT-PIC</li> <li>• PID—CBR-CCAP-LC-40G</li> <li>• PID—CBR-CCAP-LC-40G-R</li> <li>• PID—CBR-CCAP-LC-G2-R</li> <li>• PID—CBR-SUP-8X10G-PIC</li> <li>• PID—CBR-2X100G-PIC</li> </ul> <p>Digital PICs:</p> <ul style="list-style-type: none"> <li>• PID—CBR-DPIC-8X10G</li> <li>• PID—CBR-DPIC-2X100G</li> </ul> <p>Cisco cBR-8 Downstream PHY Module:</p> <ul style="list-style-type: none"> <li>• PID—CBR-D31-DS-MOD</li> </ul> <p>Cisco cBR-8 Upstream PHY Modules:</p> <ul style="list-style-type: none"> <li>• PID—CBR-D31-US-MOD</li> </ul> |



**Note** Do not use DPICs (8X10G and 2x100G) to forward IP traffic, as it may cause buffer exhaustion, leading to line card reload.

The only allowed traffic on a DPIC interface is DEPI, UEPI, and GCP traffic from the Cisco cBR-8 router to Remote PHY devices. Other traffic such as DHCP, SSH, and UTSC should flow via another router, since DPICs cannot be used for normal routing.

# Information About Commanded Power Feature for Upstream SC-QAMs

Commanded Power feature for UpStream Single Carrier Quadrature Amplitude Modulation (US SC-QAMs) supports a new method during ranging to dynamically set the transmit power level of a DOCSIS 3.1 cable modem.

To view the new commanded power levels pr upstream, use the following command:

```
Router# show cable modem [ ip-address | mac-address | cable {slot /subslot
/cable-interface-index}] verbose
```



**Note** DOCSIS 3.1 Commanded Power feature is enabled by default.

## Feature TLVs

### TLVs Affected by Commanded Power for US SC-QAMs

The following table lists the TLVs affected by the DOCSIS 3.1 Ranging Response (RNG-RSP) Commanded Power for upstream SC-QAMs:

| Name                            | Type   | DOCSIS 3.1 Value                                                                                                                                                                                      |
|---------------------------------|--------|-------------------------------------------------------------------------------------------------------------------------------------------------------------------------------------------------------|
| Power Level Adjust              | 2      | TX Power offset adjustment (signed 8-bit, 1/4-dB units)                                                                                                                                               |
| Power Offset                    | 12.4.4 | TX Power offset adjustment (signed 8-bit, 1/4-dB units)                                                                                                                                               |
| Dynamic Range Window Upper Edge | 14     | The upper edge of the Dynamic Range Window expressed in units 1/4 dB below the max allowable setting (Phi) [DOCSIS PHYv3.0].                                                                          |
| Commanded Power                 | 17     | This TLV contains the Dynamic Range Window value, P1.6load_min_set as well as the Transmit Power Level for each of the channels in the CM's Transmit Channel Set, expressed in units of quarter dBmV. |

### Commanded Power Sub-TLVs

The following table lists the sub-TLVs for DOCSIS 3.1 Commanded Power:

| Name                                                                 | Type (1 byte) | Length (1 byte) | Value (Variable Length)                                                                                                                                                  |
|----------------------------------------------------------------------|---------------|-----------------|--------------------------------------------------------------------------------------------------------------------------------------------------------------------------|
| Commanded Power                                                      | 17            | 5 + 3*N         |                                                                                                                                                                          |
| Dynamic Range Window                                                 | 17.1          | 1               | The range, in decibels, of the maximum difference in power per 1.6 MHz between multiple transmitters in a cable modem's Transmit Channel Set.                            |
| List of Upstream Channel IDs and Corresponding Transmit Power Levels | 17.2          | 3*N             | Values for each channel in the TCS: <ul style="list-style-type: none"> <li>• Bits 23 to 16: UCID</li> <li>• Bits 15 to 0: Transmit Power Level (quarter dBmV)</li> </ul> |

## Additional References

### Technical Assistance

| Description                                                                                                                                                                                                                                                                                                                                                                                                                                                                                                                                                             | Link                                                                    |
|-------------------------------------------------------------------------------------------------------------------------------------------------------------------------------------------------------------------------------------------------------------------------------------------------------------------------------------------------------------------------------------------------------------------------------------------------------------------------------------------------------------------------------------------------------------------------|-------------------------------------------------------------------------|
| <p>The Cisco Support website provides extensive online resources, including documentation and tools for troubleshooting and resolving technical issues with Cisco products and technologies.</p> <p>To receive security and technical information about your products, you can subscribe to various services, such as the Product Alert Tool (accessed from Field Notices), the Cisco Technical Services Newsletter, and Really Simple Syndication (RSS) Feeds.</p> <p>Access to most tools on the Cisco Support website requires a Cisco.com user ID and password.</p> | <a href="http://www.cisco.com/support">http://www.cisco.com/support</a> |

## Feature Information for Commanded Power for US SC-QAMs

Use Cisco Feature Navigator to find information about the platform support and software image support. Cisco Feature Navigator enables you to determine which software images support a specific software release, feature set, or platform. To access Cisco Feature Navigator, go to the <https://cfnng.cisco.com/> link. An account on the Cisco.com page is not required.





**Note** The following table lists the software release in which a given feature is introduced. Unless noted otherwise, subsequent releases of that software release train also support that feature.

**Table 129: Feature History**

| Feature Name                              | Releases                 | Feature Information                                   |
|-------------------------------------------|--------------------------|-------------------------------------------------------|
| DOCSIS 3.1 Commanded Power for US SC-QAMs | Cisco IOS XE Fuji 16.7.1 | Cisco cBR-8 Routers are integrated with this feature. |

**Table 130: Feature History**

| Feature Name                                              | Release Information          | Feature Description                                                                                                                                                              |
|-----------------------------------------------------------|------------------------------|----------------------------------------------------------------------------------------------------------------------------------------------------------------------------------|
| Upstream transmit Power Ceiling SC-QAM Channel Assignment | Cisco IOS XE Dublin 17.12.1z | Modems with restricted transmit power now benefit from this release that assigns them a set of ATDMA channels. Also, it ensures optimal path selection by checking power levels. |

Previously, single channel bounding groups pass the path selection power check. Since the OFDMA channel always passes the check, even when the modem power level exceeds the max, CMTS still pick the OFDMA channel as the bounding group. With the release of 17.12.1z, the OFDMA channel checks for path selection power check.

Previously, single OFDMA channel bounding groups were randomly pick in path selection resulting in experiencing data issues. With the release of 17.12.1z, the single OFDMA channel bounding groups are sorted by NEQ (Number 1.6mhz frequency Equivalent) with other bounding groups.

**Table 131:**

| Configuration                                                                                                     | Description                                                                                                                                                                                                                                                                                                                                                                                  |
|-------------------------------------------------------------------------------------------------------------------|----------------------------------------------------------------------------------------------------------------------------------------------------------------------------------------------------------------------------------------------------------------------------------------------------------------------------------------------------------------------------------------------|
| <pre> config t Interface cable &lt;slot&gt; 0 &lt;md-id&gt; upstream max-channel-power-offset &lt;0-12&gt; </pre> | <p>This configuration affects the upstream path selection power check outcome.</p> <p>This configurable value, extended in D3.1 modems from D3.0 modems for power check path selection code. For path selection power check, it gives a stretch to allow a modem coming online with a bigger upstream bounding group even when the modem initial ranging TX power is higher than 1.6MHz.</p> |





## CHAPTER 39

# DOCSIS3.1 Downstream Resiliency for OFDM channel

---

This document describes how to configure the DOCSIS3.1 Downstream Resiliency for OFDM channel on the Cisco cBR Series Converged Broadband Router.

Your software release may not support all the features that are documented in this module. For the latest feature information and caveats, see the release notes for your platform and software release. The Feature Information Table at the end of this document provides information about the documented features and lists the releases in which each feature is supported.

Use Cisco Feature Navigator to find information about platform support and Cisco software image support. To access Cisco Feature Navigator, go to <http://tools.cisco.com/ITDIT/CFN/>. An account on <http://www.cisco.com/> is not required.

- [Hardware Compatibility Matrix for the Cisco cBR Series Routers, on page 647](#)
- [Information about DOCSIS3.1 Downstream Resiliency for OFDM Channel, on page 649](#)
- [How to Configure DOCSIS3.1 Downstream Resiliency for OFDM Channel, on page 650](#)
- [Feature Information for DOCSIS3.1 Downstream Resiliency for OFDM Channel, on page 653](#)

## Hardware Compatibility Matrix for the Cisco cBR Series Routers



---

**Note** The hardware components that are introduced in a given Cisco IOS-XE Release are supported in all subsequent releases unless otherwise specified.

---

Table 132: Hardware Compatibility Matrix for the Cisco cBR Series Routers

| Cisco CMTS Platform                    | Processor Engine                                                                                                                                                                                  | Interface Cards                                                                                                                                                                                                                                                                                                                                                                                                                                                                                                                                                                                                                                                                                                                                                                                 |
|----------------------------------------|---------------------------------------------------------------------------------------------------------------------------------------------------------------------------------------------------|-------------------------------------------------------------------------------------------------------------------------------------------------------------------------------------------------------------------------------------------------------------------------------------------------------------------------------------------------------------------------------------------------------------------------------------------------------------------------------------------------------------------------------------------------------------------------------------------------------------------------------------------------------------------------------------------------------------------------------------------------------------------------------------------------|
| Cisco cBR-8 Converged Broadband Router | <p><b>Cisco IOS-XE Release 16.5.1 and Later Releases</b></p> <p>Cisco cBR-8 Supervisor:</p> <ul style="list-style-type: none"> <li>• PID—CBR-SUP-250G</li> <li>• PID—CBR-CCAP-SUP-160G</li> </ul> | <p><b>Cisco IOS-XE Release 16.5.1 and Later Releases</b></p> <p>Cisco cBR-8 CCAP Line Cards:</p> <ul style="list-style-type: none"> <li>• PID—CBR-LC-8D30-16U30</li> <li>• PID—CBR-LC-8D31-16U30</li> <li>• PID—CBR-RF-PIC</li> <li>• PID—CBR-RF-PROT-PIC</li> <li>• PID—CBR-CCAP-LC-40G</li> <li>• PID—CBR-CCAP-LC-40G-R</li> <li>• PID—CBR-CCAP-LC-G2-R</li> <li>• PID—CBR-SUP-8X10G-PIC</li> <li>• PID—CBR-2X100G-PIC</li> </ul> <p>Digital PICs:</p> <ul style="list-style-type: none"> <li>• PID—CBR-DPIC-8X10G</li> <li>• PID—CBR-DPIC-2X100G</li> </ul> <p>Cisco cBR-8 Downstream PHY Module:</p> <ul style="list-style-type: none"> <li>• PID—CBR-D31-DS-MOD</li> </ul> <p>Cisco cBR-8 Upstream PHY Modules:</p> <ul style="list-style-type: none"> <li>• PID—CBR-D31-US-MOD</li> </ul> |



**Note** Do not use DPICs (8X10G and 2x100G) to forward IP traffic, as it may cause buffer exhaustion, leading to line card reload.

The only allowed traffic on a DPIC interface is DEPI, UEPI, and GCP traffic from the Cisco cBR-8 router to Remote PHY devices. Other traffic such as DHCP, SSH, and UTSC should flow via another router, since DPICs cannot be used for normal routing.

# Information about DOCSIS3.1 Downstream Resiliency for OFDM Channel

When DOCSIS3.1 CM reports non-primary RF channel failure for SCQAM or OFDM channel, actions performed by downstream resiliency is the same as DOCSIS3.0 CM. In other words, if RF channel impairment is below the resiliency threshold, CMs service flows are moved to Resiliency Bonding Group (RBG) or Narrow Band (NB) interface. If RF channel impairment is above the resiliency threshold, the impaired RF channel is temporarily removed from the bonding group.

The following table summarizes the CM-STATUS events for OFDM channel, and the action to be taken by the downstream resiliency module:

**Table 133: CM-STATUS events for OFDM channel**

| Event Type Code | Event Description                                                                                         | DS Resiliency Action                                                                                         |
|-----------------|-----------------------------------------------------------------------------------------------------------|--------------------------------------------------------------------------------------------------------------|
| 1               | MDD timeout                                                                                               | Move CM's service flows to RBG/NB or suspend RF from BG.                                                     |
| 2               | FEC lock failure                                                                                          | Move CM's service flows to RBG/NB or suspend RF from BG.                                                     |
| 4               | MDD recovery                                                                                              | Move CM's service flows back to original BG.                                                                 |
| 5               | FEC lock recovery                                                                                         | Move CM's service flows back to original BG.                                                                 |
| 16              | DS OFDM profile failure. A loss of FEC lock on one of the assigned downstream OFDM profiles of a channel. | DS OFDM Profile Manager will handle this event and take action.                                              |
| 20              | NCP profile failure. Loss of FEC lock on NCP.                                                             | Move CM's service flows to RBG/NB or suspend RF from BG.                                                     |
| 21              | Loss of FEC lock on the PLC.                                                                              | Move CM's service flows to RBG/NB or suspend RF from BG.                                                     |
| 22              | NCP profile recovery.                                                                                     | Move CM's service flows back to original BG.                                                                 |
| 23              | FEC recovery on PLC channel.                                                                              | Move CM's service flows back to original BG.                                                                 |
| 24              | FEC recovery on OFDM profile.                                                                             | Recovery of impairment reported by event 16. DS OFDM Profile Manager will handle this event and take action. |

# How to Configure DOCSIS3.1 Downstream Resiliency for OFDM Channel

## Configuring DOCSIS3.1 Downstream Resiliency for OFDM Channel

User must configure the command **cable rf-change-trigger percent *value* count *number*** to enable the downstream resiliency functionality.

To configure the trigger thresholds specific to OFDM RF impairment, follow the steps below:

```
enable
configure terminal
cable ofdm-rf-change-trigger percent value counter number [no-ncp-plc]
```

Starting from Cisco IOS XE Fuji 16.10.1d release, you can exclude NCP and PLC reports separately by following these steps:

```
enable
configure terminal
cable ofdm-rf-change-trigger percent value counter number [no-ncp] [no-plc]
```

Trigger thresholds *value* and *number* apply globally to the non-primary OFDM RF channels. If this command is not configured, the trigger thresholds configured by the command **cable rf-change-trigger percent *value* count *number*** will be used for the non-primary OFDM channels.

With **no-ncp-plc** configured in the command, this feature will not take any action when CM reports CM-STATUS-EVENT 20 or 21.



---

**Note** The **cable rf-change-trigger percent *value* count *number*** command is optional and the configured trigger thresholds apply to non-primary OFDM channels only.

---

## Displaying OFDM Specific CM-STATUS Events

To display the statistics of the OFDM specific CM-STATUS events, use the **show cable modem wideband rcs-status** command as shown in the example below:

```
router#show cable modem 4800.33ea.7072 wideband rcs-status verbose
CM : 4800.33ea.7072
RF : 3/0/0 0
  Status                : UP
  FEC/QAM Failure       : 0
  Dup FEC/QAM Failure   : 0
  FEC/QAM Recovery      : 0
  Dup FEC/QAM Recovery  : 0
  MDD Failure           : 0
  Dup MDD Failure       : 0
  MDD Recovery          : 0
  Dup MDD Recovery      : 0
  Flaps                 : 0
  Flap Duration         : 00:00
```

```

RF : 3/0/0 1
  Status : UP
  FEC/QAM Failure : 0
  Dup FEC/QAM Failure : 0
  FEC/QAM Recovery : 0
  Dup FEC/QAM Recovery : 0
  MDD Failure : 0
  Dup MDD Failure : 0
  MDD Recovery : 0
  Dup MDD Recovery : 0
  Flaps : 0
  Flap Duration : 00:00
RF : 3/0/0 159
  Status : UP
  FEC/QAM Failure : 0
  Dup FEC/QAM Failure : 0
  FEC/QAM Recovery : 0
  Dup FEC/QAM Recovery : 0
  MDD Failure : 0
  Dup MDD Failure : 0
  MDD Recovery : 0
  Dup MDD Recovery : 0
  NCP PROF Failure : 2 May 8 15:14:24
  Dup NCP PROF Failure : 0
  NCP PROF Recovery : 1 May 8 15:15:18
  Dup NCP PROF Recovery : 0
  PLC Lock Failure : 1 May 8 15:14:47
  Dup PLC Lock Failure : 0
  PLC Lock Recovery : 1 May 8 15:15:46
  Dup PLC Lock Recovery : 0
  Flaps : 0
  Flap Duration : 00:00
  OFDM Profile Id : 2
  Status : UP
  Profile Failure : 1 May 8 15:16:18
  DUP Profile Failure : 0
  Profile Recovery : 1 May 8 15:16:44
  DUP Profile Recovery : 0

```

## Managing Profile Zero CM-STATUS Events

A cable modem sends a CM-STATUS event 16 message to the CMTS to indicate a downstream OFDM profile failure. CMTS would react to CM-STATUS events by either downgrading the profile or changing the cable modem status to partial service.

When a cable modem reports a CM-STATUS event 16 message for profile 0, the profile is neither added to the unfit list, nor any action is taken. As a result, the cable modem continues to send data on OFDM profile 0 which can lead to packet loss. This can result in FEC errors on profile 0 for the cable modem. Periodic RxMER measurements do not show the problem, which leaves the cBR-8 still scheduling data on an OFDM channel using profile 0. This may cause downgraded performance for the cable modem.

## Downstream Resiliency Enhancements for Profile 0

Table 134: Feature History

| Feature Name                       | Release Information          | Feature Description                                                                                                                                                                                                                                                                                                                                                                                                                                                                                                                                                                                                                          |
|------------------------------------|------------------------------|----------------------------------------------------------------------------------------------------------------------------------------------------------------------------------------------------------------------------------------------------------------------------------------------------------------------------------------------------------------------------------------------------------------------------------------------------------------------------------------------------------------------------------------------------------------------------------------------------------------------------------------------|
| Downstream Resiliency Enhancements | Cisco IOS XE Dublin 17.12.1z | <p>With this release, the CMTS response to a cable modem's CM-STATUS event 16 message is optimized for profile 0.</p> <ul style="list-style-type: none"> <li>• CM-STATUS Event 16 on profile 0 operates as a downstream impairment.</li> <li>• CM-STATUS Event 24 on profile 0 operates as a downstream impairment recovery.</li> </ul> <p>Profile 0 is processed in the same way as FEC Loss or MDD timeout and hence experiences the same benefits of better performance and reduced packet loss.</p> <p><b>Command introduced:</b> <code>ofdm-rf-change-trigger prof-zero-fail dampen-time seconds recovery-multiplier number</code>.</p> |

When a cable modem sends a CM-STATUS event 16 message to the CMTS to indicate a downstream OFDM profile failure, CMTS does not downgrade the profile or change the cable modem status to partial service. Instead, downstream resiliency rules are applied, resulting in a better handling of Profile 0.

### Handling CM-STATUS Event 16

When a CMTS handles a CM-STATUS event 16 on profile 0 as a downstream impairment:

- Downstream resiliency moves the OFDM channel to the **Down** state after the configured *dampen-time*.
- Cable modem enters a downstream partial-service (**p-online**) state.
- Cable modem downstream service flows (SF) move to RBG or NB with existing downstream resiliency logic.

### Handling CM-STATUS Event 24

When a CMTS handles a CM-STATUS event 24 on profile 0 as a downstream impairment recovery:

- Downstream resiliency uses this event to indicate the recovery of event 16 impairment.
- CMTS moves the OFDM channel to **Up** state after the configured duration (dampen time \* recovery multiplier).
- Cable modem moves back to wideband online (**w-online**) state.
- Cable modem downstream service flows (SF) move to the original bonding group existing downstream resiliency logic.

See

- [cable rf-change-dampen-time](#)



- [cable rf-change-up-multiplier](#)

### Configuring Downstream Resiliency for Profile 0

Configuring downstream resiliency for profile 0 is disabled by default. This sample configuration shows how to configure Downstream Resiliency for profile 0:

```
Router# configure terminal
Router(config)# cable ofdm-rf-change-trigger prof-zero-fail dampen-time 20 recovery-multiplier
2
```

- Use the **dampen-time** *seconds* option to specify the time in seconds for a non-primary RF channel to remain in its current state before downstream resiliency processes a CM-STATUS event.
- Use the **recovery-multiplier** to set an event specific recovery delay that is equal to the **dampen-time** in seconds times the recovery-multiplier value.

The following example shows how to disable downstream resiliency for profile 0:

```
Router# configure terminal
Router(config)# no cable ofdm-rf-change-trigger
```

Disabling downstream resiliency for profile 0, resets *dampen-time* and *recovery-multiplier* values to 0. No resiliency action for CM-STATUS 16 and 24 is performed for profile 0 if this feature is disabled. The following example shows a sample configuration to disable the feature.

```
Router# configure terminal
Router(config)# no cable ofdm-rf-change-trigger
Router(config)# end
```

```
Router# show run all | sec prof-zero-fail
cable ofdm-rf-change-trigger prof-zero-fail dampen-time 0 recovery-multiplier 0
```

## Feature Information for DOCSIS3.1 Downstream Resiliency for OFDM Channel

Use Cisco Feature Navigator to find information about the platform support and software image support. Cisco Feature Navigator enables you to determine which software images support a specific software release, feature set, or platform. To access Cisco Feature Navigator, go to the <https://cfng.cisco.com/> link. An account on the Cisco.com page is not required.



---

**Note** The following table lists the software release in which a given feature is introduced. Unless noted otherwise, subsequent releases of that software release train also support that feature.

---

*Table 135: Feature Information for DOCSIS3.1 Downstream Resiliency for OFDM Channel*

| <b>Feature Name</b>                              | <b>Releases</b>             | <b>Feature Information</b>                                                       |
|--------------------------------------------------|-----------------------------|----------------------------------------------------------------------------------|
| DOCSIS3.1 Downstream Resiliency for OFDM Channel | Cisco IOS XE Everest 16.7.1 | This feature was integrated on the Cisco cBR Series Converged Broadband Routers. |



## CHAPTER 40

# DOCSIS 3.1 OFDMA Channel Configuration

---

This document describes how to configure the OFDMA channel on the Cisco cBR Series Converged Broadband Router.

- [Hardware Compatibility Matrix for the Cisco cBR Series Routers, on page 655](#)
- [Information about OFDMA Channel Configuration, on page 657](#)
- [Configure OFDMA Channel, on page 658](#)
- [Feature Information for DOCSIS 3.1 OFDMA Channel Configuration, on page 674](#)

## Hardware Compatibility Matrix for the Cisco cBR Series Routers



---

**Note** The hardware components that are introduced in a given Cisco IOS-XE Release are supported in all subsequent releases unless otherwise specified.

---

Table 136: Hardware Compatibility Matrix for the Cisco cBR Series Routers

| Cisco CMTS Platform                    | Processor Engine                                                                                                                                                                                  | Interface Cards                                                                                                                                                                                                                                                                                                                                                                                                                                                                                                                                                                                                                                                                                                                                                                                 |
|----------------------------------------|---------------------------------------------------------------------------------------------------------------------------------------------------------------------------------------------------|-------------------------------------------------------------------------------------------------------------------------------------------------------------------------------------------------------------------------------------------------------------------------------------------------------------------------------------------------------------------------------------------------------------------------------------------------------------------------------------------------------------------------------------------------------------------------------------------------------------------------------------------------------------------------------------------------------------------------------------------------------------------------------------------------|
| Cisco cBR-8 Converged Broadband Router | <p><b>Cisco IOS-XE Release 16.5.1 and Later Releases</b></p> <p>Cisco cBR-8 Supervisor:</p> <ul style="list-style-type: none"> <li>• PID—CBR-SUP-250G</li> <li>• PID—CBR-CCAP-SUP-160G</li> </ul> | <p><b>Cisco IOS-XE Release 16.5.1 and Later Releases</b></p> <p>Cisco cBR-8 CCAP Line Cards:</p> <ul style="list-style-type: none"> <li>• PID—CBR-LC-8D30-16U30</li> <li>• PID—CBR-LC-8D31-16U30</li> <li>• PID—CBR-RF-PIC</li> <li>• PID—CBR-RF-PROT-PIC</li> <li>• PID—CBR-CCAP-LC-40G</li> <li>• PID—CBR-CCAP-LC-40G-R</li> <li>• PID—CBR-CCAP-LC-G2-R</li> <li>• PID—CBR-SUP-8X10G-PIC</li> <li>• PID—CBR-2X100G-PIC</li> </ul> <p>Digital PICs:</p> <ul style="list-style-type: none"> <li>• PID—CBR-DPIC-8X10G</li> <li>• PID—CBR-DPIC-2X100G</li> </ul> <p>Cisco cBR-8 Downstream PHY Module:</p> <ul style="list-style-type: none"> <li>• PID—CBR-D31-DS-MOD</li> </ul> <p>Cisco cBR-8 Upstream PHY Modules:</p> <ul style="list-style-type: none"> <li>• PID—CBR-D31-US-MOD</li> </ul> |



**Note** Do not use DPICs (8X10G and 2x100G) to forward IP traffic, as it may cause buffer exhaustion, leading to line card reload.

The only allowed traffic on a DPIC interface is DEPI, UEPI, and GCP traffic from the Cisco cBR-8 router to Remote PHY devices. Other traffic such as DHCP, SSH, and UTSC should flow via another router, since DPICs cannot be used for normal routing.

# Information about OFDMA Channel Configuration

## OFDMA Channels

DOCSIS 3.1 introduces modes for higher throughput and higher spectral efficiency while still allowing backward compatibility to DOCSIS 3.0. Orthogonal Frequency Division Multiple Access (OFDMA) channel has following features:

- Frequency-range up to 96 MHz
- Upstream spectrum 5 – 204 MHz
- 25 kHz subcarrier spacing
- OFDMA Channel-width up to 80 MHz - The Cisco IOS XE Fuji 16.7.x release supports configuration of a single 80 MHz OFDMA channel on every port of a line card.
- OFDMA Channel-width up to 96 MHz - The Cisco IOS XE 16.8.x release supports configuration of a single 96 MHz OFDMA channel on every port of a line card.
- OFDMA Upstream spectrum 5 – 85 MHz - The Cisco IOS XE Fuji 16.7.x supports a maximum frequency value of 85 Mhz for an OFDMA channel.
- OFDMA Upstream spectrum 5 – 204 MHz - The Cisco IOS XE 16.8.x extends the supported maximum frequency value of an OFDMA channel from 85 Mhz to 204 Mhz.

For a specific subcarrier spacing, the number of subcarriers on an OFDMA channel depends on the channel width.

| Channel Width | 50 kHz | 25 kHz |
|---------------|--------|--------|
| 48 MHz        | 960    | 1920   |
| 96 MHz        | 1920   | 3840   |



**Note** When the OFDMA is configured with SC-QAMs on the same port pair, it is recommended to configure no more than 45 MHz OFDMA per port, or 90 MHz per port pair in Cisco IOS XE Everest Release 16.6.1.

## Modulation Profile

A globally configured OFDMA modulation profile defines modulation orders and pilot patterns for different interval usage codes (IUC). You can also use it to assign parameters for initial ranging and fine ranging.

The following table gives information on the supported modulation orders.

| Modulation Order | Support |
|------------------|---------|
| BPSK             | Yes     |

| Modulation Order | Support |
|------------------|---------|
| QPSK             | Yes     |
| 8-QAM            | Yes     |
| 16-QAM           | Yes     |
| 32-QAM           | Yes     |
| 64-QAM           | Yes     |
| 128-QAM          | Yes     |
| 256-QAM          | Yes     |
| 512-QAM          | Yes     |
| 1024-QAM         | Yes     |
| 2048-QAM         | Yes     |
| 4096-QAM         | No      |

## OFDMA Channel Exclusion Band

Ranges of frequencies can be excluded from all OFDMA channels on a port using the **ofdma-frequency-exclusion-band** command.

Exclusion and unused bands apply to OFDMA channels only. OFDMA channel never use frequencies in exclusion band. So the legacy SC-QAM channel can be placed in this band. OFDMA channel does not use frequencies in unused band set by **ofdma-frequency-unused-band** command for data traffic, but can send probes in them.

## Configure OFDMA Channel

### Configuring OFDMA Controller Profile

To configure upstream controller profile, follow the steps below:

```
enable
configure terminal
cable mod-profile-ofdma id
subcarrier-spacing value
initial-rng-subcarrier value
fine-rng-subcarrier value
data-iuc id modulation value pilot-pattern value
```

Here is a configuration example:

```
Router# enable
Router# configure terminal
```

```

Router(config)#cable mod-profile-ofdma 425
Router(config)#subcarrier-spacing 25KHz
Router(config)#initial-rng-subcarrier 64
Router(config)#fine-rng-subcarrier 192
Router(config)#data-iuc 5 modulation 2048-QAM pilot-pattern 11
Router(config)#data-iuc 6 modulation 1024-QAM pilot-pattern 11
Router(config)#data-iuc 9 modulation 256-QAM pilot-pattern 11
Router(config)#data-iuc 10 modulation 128-QAM pilot-pattern 11
Router(config)#data-iuc 11 modulation 64-QAM pilot-pattern 11
Router(config)#data-iuc 12 modulation 32-QAM pilot-pattern 11
Router(config)#data-iuc 13 modulation 16-QAM pilot-pattern 11
Router(config)# cable mod-profile-ofdma 466
Router(config-ofdma-mod-profile)# subcarrier-spacing 50KHz
Router(config-ofdma-mod-profile)# initial-rng-subcarrier 64
Router(config-ofdma-mod-profile)# fine-rng-subcarrier 128
Router(config-ofdma-mod-profile)# data-iuc 13 modulation 1024-QAM pilot-pattern 2
Router(config-ofdma-mod-profile)# data-iuc 13 modulation 1024-QAM pilot-pattern 2
Router(config-ofdma-mod-profile)# exit
Router(config)# cable mod-profile-ofdma 423
Router(config-ofdma-mod-profile)# subcarrier-spacing 25KHz
Router(config-ofdma-mod-profile)# initial-rng-subcarrier 64
Router(config-ofdma-mod-profile)# fine-rng-subcarrier 128
Router(config-ofdma-mod-profile)# data-iuc 6 modulation 1024-QAM pilot-pattern 8
Router(config-ofdma-mod-profile)# data-iuc 9 modulation 1024-QAM pilot-pattern 8
Router(config-ofdma-mod-profile)# data-iuc 10 modulation 512-QAM pilot-pattern 8
Router(config-ofdma-mod-profile)# data-iuc 11 modulation 256-QAM pilot-pattern 8
Router(config-ofdma-mod-profile)# data-iuc 12 modulation 128-QAM pilot-pattern 9
Router(config-ofdma-mod-profile)# data-iuc 13 modulation 64-QAM pilot-pattern 9

```



**Note** Subcarrier spacing must match the subcarrier spacing of each channel profile in which it is configured.

## Verifying OFDMA Modulation Profile Configuration

To display the OFDMA modulation profile details, use the **show cable modulation-profile ofdma** command as shown in the example below:

```

Router# show cable modulation-profile ofdma
Mod  Subc      IUC type  Act  Preamble  Bit          Pilot
      Spacing                subc Symbols  Loading    Pattern
421  25KHz      3  (IR)    64      4
      4  (FR)    192     1
      13 (data)                16-QAM     8
423  25KHz      3  (IR)    64      4
      4  (FR)    128     1
      6  (data)                1024-QAM  8
      10 (data)               512-QAM  8
      11 (data)               256-QAM  8
      12 (data)               128-QAM  9
      13 (data)               64-QAM   9
461  50KHz      3  (IR)    32      4
      4  (FR)    192     1
      13 (data)                16-QAM     1
466  50KHz      3  (IR)    64      4
      4  (FR)    128     1

```

13 (data)

1024-QAM 2

## Configuring OFDMA Channel

Feature History

**Table 137: Feature History**

| Feature Name                                       | Release Information            | Feature Description                                                                                                       |
|----------------------------------------------------|--------------------------------|---------------------------------------------------------------------------------------------------------------------------|
| Remote PHY 2 OFDMA channels per controller support | Cisco IOS XE Bengaluru 17.6.1x | This feature allows you to configure two OFDMA channels on the same Upstream-Cable controller in a Remote PHY deployment. |

To configure the OFDMA channel, follow these steps:

```
enable
configure terminal
controller Upstream-Cable slot/subslot/port
us-channel id docsis-mode ofdma
us-channel id subcarrier-spacing value
us-channel id frequency-range start-value end-value
us-channel id modulation-profile id
us-channel id cyclic-prefix value roll-off-period value
us-channel id symbols-per-frame value
us-channel id data-iuc id band start-value end-value modulation value pilot-pattern
value
```

Here is a configuration example:

```
Router# enable
Router# configure terminal
Router(config)# controller Upstream-Cable 1/0/4
Router(config-controller)# us-channel 12 docsis-mode ofdma
Router(config-controller)# us-channel 12 subcarrier-spacing 25KHz
Router(config-controller)# us-channel 12 frequency-range 40000000 85000000
Router(config-controller)# us-channel 12 modulation-profile 423
Router(config-controller)# us-channel 12 cyclic-prefix 640 roll-off-period 224
Router(config-controller)# us-channel 12 symbols-per-frame 9
Router(config-controller)# us-channel 12 data-iuc 9 band 50000000 60000000 modulation 512-QAM
pilot-pattern 8
Router(config-controller)# no us-channel 12 shutdown
```

This is a configuration example for two OFDMA channels in Remote PHY deployment:

```
Router# enable
Router# configure terminal
Router(config)# cable upstream controller profile 1
Router(config-controller-profile)# us-channel 12 docsis-mode ofdma
Router(config-controller-profile)# us-channel 12 subcarrier-spacing 25KHz
Router(config-controller-profile)# us-channel 12 modulation-profile 423
Router(config-controller-profile)# us-channel 12 frequency-range 40000000 85000000
Router(config-controller-profile)# us-channel 12 initial-rng-frequency-start 50000000
Router(config-controller-profile)# us-channel 12 cyclic-prefix 96 roll-off-period 64
Router(config-controller-profile)# us-channel 12 symbols-per-frame 12
Router(config-controller-profile)# no us-channel 12 shutdown
```



```
Router(config-controller-profile)# us-channel 13 docsis-mode ofdma
Router(config-controller-profile)# us-channel 13 subcarrier-spacing 25KHz
Router(config-controller-profile)# us-channel 13 modulation-profile 423
Router(config-controller-profile)# us-channel 13 frequency-range 108000000 204000000
Router(config-controller-profile)# us-channel 13 initial-rng-frequency-start 118000000
Router(config-controller-profile)# us-channel 13 cyclic-prefix 96 roll-off-period 64
Router(config-controller-profile)# us-channel 13 symbols-per-frame 12
Router(config-controller-profile)# no us-channel 13 shutdown

Router# configure terminal
Router(config)# cable rpd rpd-20
Router(config-rpd)# description RPD20
Router(config-rpd)# identifier badb.1111.1111
Router(config-rpd)# core-interface Te7/1/3
Router(config-rpd-core)# principal
Router(config-rpd-core)# rpd-ds 0 downstream-cable 7/0/31 profile 2
Router(config-rpd-core)# rpd-us 0 upstream-cable 7/0/63 profile 1
```

**Note**

- OFDMA uses us-channel range 12–15.
- Change docsis-mode to **ofdma** to enable OFDMA configuration options. These options are enabled by default on us-channel 12–15.
- The default us-channel is 12 docsis-mode (does not return configuration to default).
- In Cisco IOS XE Fuji 16.7.x and earlier releases, we recommend that you configure no more than four active SC-QAMs on the same controller while an OFDMA channel is present.
- You can configure a maximum of one OFDMA channel per controller. Starting from Cisco IOS XE Gibraltar 16.10.x release, two OFDMA channels—us-channel 12 and us-channel 13 can be configured per controller. Starting from Cisco IOS XE Bengaluru 17.6.1x release, you can configure two OFDMA channels in Remote PHY deployment.
- In Cisco IOS XE Everest 16.6.x release, place the OFDMA channel in the range from 40 through 85 MHz.
- In Cisco IOS XE Fuji 16.7.x and following releases, place OFDMA channels in the range from 5 through 85 MHz.
- Values of the options are often interdependent, changing one value may change other values or make them invalid.
- We recommend setting the subcarrier spacing and frequency range first. Frequency range must be increments of 50 kHz.
- Each fiber node supports two OFDMA channels.
- Each bonding group supports two OFDMA channels.
- Each controller pair supports a maximum of 192-Mhz OFDMA spectrum in iCCAP deployment.
- Each CBR-CCAP-LC-G2-R card supports a maximum of 32 OFDMA channels.

## Verifying OFDMA Channel Configuration

To display the OFDMA channel configuration, use the **show controllers upstream-Cable us-channel** command as shown in the example below:

```
Router# show controllers upstream-Cable 1/0/4 us-channel 12
USPHY OFDMA support: FULL
```

```
Controller 1/0/4 upstream 12  AdminState:UP OpState: UP
ofdma mode enabled
Channel Freq Range 35.500 MHz to 79.500 MHz
Channel Subcarrier Index Range Cfg: 74, 953 Op: 74, 953
Channel SC0 Freq Cfg: 31.800 MHz Op: 31.800 MHz
#Excl bands: 2
( 0, 73), ( 954, 2047),
#Unused bands: 0
Cyclic Prefix Size 96,  Rolloff Period Size 64
Subcarrier Spacing 50KHz,  Symbols Per Frame 18 Subcarrier Per Minislot: 8

Modulation Profile (ID 466, Subcarrier Spacing 50KHz)
  IUC type      Cfg  Act  Preamble Bit      Pilot
    subc  subc  Symbols  Loading  Pattern
  3  (IR)   64   64     4      -      -
  4  (FR)  128  128     1      -      -
  13 (data)  -    -     -    1024-QAM  2
Calculated Data burst profile:
IUC  Group  Bit      Pilot  Start  Consec
      Loading  Pattern Mslot  Mslot
13   0      1024-QAM  2      0      109

#Total mslots:110 #Fine Rng capable:95 #Initial Rng capable:103
Initial Rng - Freq 50.000MHz mslotOffset:36 #mslot in frame:8
Minislot mapping:  mslot#(start_sc start_freq(Mhz) end_sc end_freq(Mhz))
mslot type(E-Edge; B-Body; S-Share with SCQAM;
I-Initial rng capable; F-Fine rng capable)
(next Fine Rng capable minislot if current is not capable))
0  ( 74, 35.500, 81, 35.850, EIF ( - ) ), 1  ( 82, 35.900, 89, 36.250, BIF ( - ) ),
2  ( 90, 36.300, 97, 36.650, BIF ( - ) ), 3  ( 98, 36.700, 105, 37.050, BIF ( - ) ),
4  ( 106, 37.100, 113, 37.450, BIF ( - ) ), 5  ( 114, 37.500, 121, 37.850, BIF ( - ) ),
6  ( 122, 37.900, 129, 38.250, BIF ( - ) ), 7  ( 130, 38.300, 137, 38.650, BIF ( - ) ),
8  ( 138, 38.700, 145, 39.050, BIF ( - ) ), 9  ( 146, 39.100, 153, 39.450, BIF ( - ) ),
10 ( 154, 39.500, 161, 39.850, BIF ( - ) ), 11 ( 162, 39.900, 169, 40.250, BIF ( - ) ),
12 ( 170, 40.300, 177, 40.650, BIF ( - ) ), 13 ( 178, 40.700, 185, 41.050, BIF ( - ) ),
14 ( 186, 41.100, 193, 41.450, BIF ( - ) ), 15 ( 194, 41.500, 201, 41.850, BIF ( - ) ),
16 ( 202, 41.900, 209, 42.250, BIF ( - ) ), 17 ( 210, 42.300, 217, 42.650, BIF ( - ) ),
18 ( 218, 42.700, 225, 43.050, BIF ( - ) ), 19 ( 226, 43.100, 233, 43.450, BIF ( - ) ),
20 ( 234, 43.500, 241, 43.850, BIF ( - ) ), 21 ( 242, 43.900, 249, 44.250, BIF ( - ) ),
22 ( 250, 44.300, 257, 44.650, BIF ( - ) ), 23 ( 258, 44.700, 265, 45.050, BIF ( - ) ),
24 ( 266, 45.100, 273, 45.450, BIF ( - ) ), 25 ( 274, 45.500, 281, 45.850, BIF ( - ) ),

26 ( 282, 45.900, 289, 46.250, BIF ( - ) ), 27 ( 290, 46.300, 297, 46.650, BIF ( - ) ),
28 ( 298, 46.700, 305, 47.050, BIF ( - ) ), 29 ( 306, 47.100, 313, 47.450, BIF ( - ) ),
30 ( 314, 47.500, 321, 47.850, BIF ( - ) ), 31 ( 322, 47.900, 329, 48.250, BIF ( - ) ),
32 ( 330, 48.300, 337, 48.650, BIF ( - ) ), 33 ( 338, 48.700, 345, 49.050, BIF ( - ) ),
34 ( 346, 49.100, 353, 49.450, BIF ( - ) ), 35 ( 354, 49.500, 361, 49.850, BIF ( - ) ),
36 ( 362, 49.900, 369, 50.250, BIF ( - ) ), 37 ( 370, 50.300, 377, 50.650, BIF ( - ) ),
38 ( 378, 50.700, 385, 51.050, BIF ( - ) ), 39 ( 386, 51.100, 393, 51.450, BIF ( - ) ),
40 ( 394, 51.500, 401, 51.850, BIF ( - ) ), 41 ( 402, 51.900, 409, 52.250, BIF ( - ) ),
42 ( 410, 52.300, 417, 52.650, BIF ( - ) ), 43 ( 418, 52.700, 425, 53.050, BIF ( - ) ),
44 ( 426, 53.100, 433, 53.450, BIF ( - ) ), 45 ( 434, 53.500, 441, 53.850, BIF ( - ) ),
46 ( 442, 53.900, 449, 54.250, BIF ( - ) ), 47 ( 450, 54.300, 457, 54.650, BIF ( - ) ),
48 ( 458, 54.700, 465, 55.050, BIF ( - ) ), 49 ( 466, 55.100, 473, 55.450, BIF ( - ) ),
```

```

50 ( 474, 55.500, 481, 55.850, BIF ( - ) ), 51 ( 482, 55.900, 489, 56.250, BIF ( - ) ),
52 ( 490, 56.300, 497, 56.650, BIF ( - ) ), 53 ( 498, 56.700, 505, 57.050, BIF ( - ) ),
54 ( 506, 57.100, 513, 57.450, BIF ( - ) ), 55 ( 514, 57.500, 521, 57.850, BIF ( - ) ),
56 ( 522, 57.900, 529, 58.250, BIF ( - ) ), 57 ( 530, 58.300, 537, 58.650, BIF ( - ) ),
58 ( 538, 58.700, 545, 59.050, BIF ( - ) ), 59 ( 546, 59.100, 553, 59.450, BIF ( - ) ),
60 ( 554, 59.500, 561, 59.850, BIF ( - ) ), 61 ( 562, 59.900, 569, 60.250, BIF ( - ) ),
62 ( 570, 60.300, 577, 60.650, BIF ( - ) ), 63 ( 578, 60.700, 585, 61.050, BIF ( - ) ),
64 ( 586, 61.100, 593, 61.450, BIF ( - ) ), 65 ( 594, 61.500, 601, 61.850, BIF ( - ) ),
66 ( 602, 61.900, 609, 62.250, BIF ( - ) ), 67 ( 610, 62.300, 617, 62.650, BIF ( - ) ),
68 ( 618, 62.700, 625, 63.050, BIF ( - ) ), 69 ( 626, 63.100, 633, 63.450, BIF ( - ) ),
70 ( 634, 63.500, 641, 63.850, BIF ( - ) ), 71 ( 642, 63.900, 649, 64.250, BIF ( - ) ),
72 ( 650, 64.300, 657, 64.650, BIF ( - ) ), 73 ( 658, 64.700, 665, 65.050, BIF ( - ) ),
74 ( 666, 65.100, 673, 65.450, BIF ( - ) ), 75 ( 674, 65.500, 681, 65.850, BIF ( - ) ),
76 ( 682, 65.900, 689, 66.250, BIF ( - ) ), 77 ( 690, 66.300, 697, 66.650, BIF ( - ) ),
78 ( 698, 66.700, 705, 67.050, BIF ( - ) ), 79 ( 706, 67.100, 713, 67.450, BIF ( - ) ),
80 ( 714, 67.500, 721, 67.850, BIF ( - ) ), 81 ( 722, 67.900, 729, 68.250, BIF ( - ) ),
82 ( 730, 68.300, 737, 68.650, BIF ( - ) ), 83 ( 738, 68.700, 745, 69.050, BIF ( - ) ),
84 ( 746, 69.100, 753, 69.450, BIF ( - ) ), 85 ( 754, 69.500, 761, 69.850, BIF ( - ) ),
86 ( 762, 69.900, 769, 70.250, BIF ( - ) ), 87 ( 770, 70.300, 777, 70.650, BIF ( - ) ),
88 ( 778, 70.700, 785, 71.050, BIF ( - ) ), 89 ( 786, 71.100, 793, 71.450, BIF ( - ) ),
90 ( 794, 71.500, 801, 71.850, BIF ( - ) ), 91 ( 802, 71.900, 809, 72.250, BIF ( - ) ),
92 ( 810, 72.300, 817, 72.650, BIF ( - ) ), 93 ( 818, 72.700, 825, 73.050, BIF ( - ) ),
94 ( 826, 73.100, 833, 73.450, BIF ( - ) ), 95 ( 834, 73.500, 841, 73.850, BI ( 0 ) ),
96 ( 842, 73.900, 849, 74.250, BI ( 0 ) ), 97 ( 850, 74.300, 857, 74.650, BI ( 0 ) ),
98 ( 858, 74.700, 865, 75.050, BI ( 0 ) ), 99 ( 866, 75.100, 873, 75.450, BI ( 0 ) ),
100( 874, 75.500, 881, 75.850, BI ( 0 ) ), 101( 882, 75.900, 889, 76.250, BI ( 0 ) ),
102( 890, 76.300, 897, 76.650, BI ( 0 ) ), 103( 898, 76.700, 905, 77.050, B ( 0 ) ),
104( 906, 77.100, 913, 77.450, B ( 0 ) ), 105( 914, 77.500, 921, 77.850, B ( 0 ) ),
106( 922, 77.900, 929, 78.250, B ( 0 ) ), 107( 930, 78.300, 937, 78.650, B ( 0 ) ),
108( 938, 78.700, 945, 79.050, B ( 0 ) ), 109( 946, 79.100, 953, 79.450, B ( 0 ) ),

```

Mapped to connector 4 and receiver 108

```

Bind to Cable1/0/4 US4
MER(SNR) - Unknown - no modems online.
Spectrum Group is unassigned
Nominal Input Power Level 0 dBmV

```

```

UCD procedures on lch 0
UCD ucd-proxy-timeout (0 ) ucd-proxy-wrong-ack (0 )

```

## Configure Exclusion / Unused Bands

An OFDMA channel never uses frequencies located in exclusion bands. OFDMA probes are sent on frequencies located in the unused bands. Therefore exclusion bands must be used to prevent interference with SC-QAM channels. To configure the Exclusion / Unused Bands, follow the steps below:

```

enable
configure terminal
controller Upstream-Cable slot/subslot/port
cable ofdma-frequency-exclusion-band start-value end-value
cable ofdma-frequency-unused-band start-value end-value

```

Here is a configuration example:

```

Router# enable
Router# configure terminal
Router(config)# controller Upstream-Cable 1/0/2
Router(config-controller)# cable ofdma-frequency-exclusion-band 48000000 54200000
Router(config-controller)# cable ofdma-frequency-unused-band 50000000 52000000

```

```

Router(config-controller)# us-channel 12 docsis-mode ofdma
Router(config-controller)# us-channel 12 subcarrier-spacing 25KHz
Router(config-controller)# us-channel 12 modulation-profile 423
Router(config-controller)# us-channel 12 frequency-range 45000000 70000000
Router(config-controller)# us-channel 12 cyclic-prefix 96 roll-off-period 64
Router(config-controller)# us-channel 12 symbols-per-frame 18

```



**Note** In releases before Cisco IOS XE Dublin 17.12.1w you can only configure or modify exclusion/unused bands, when all the OFDMA channels within the controller are shut down.

Starting with Cisco IOS XE Dublin 17.12.1w, you can configure or modify exclusion / unused bands when OFDMA channels are in UP state, the new changes are dynamically applied to all the OFDMA channels.

## Verifying Exclusion / Unused Bands

To display the Exclusion / Unused Band configuration, use the **show controllers upstream-Cable us-channel** command as shown in the example below:

```

Router# show controllers upstream-Cable 1/0/2 us-channel 12
USPHY OFDMA support: FULL

Controller Exclusion Freq List:
( 40.000 MHz, 44.200 MHz),
Controller Unused Freq List:
( 50.000 MHz, 52.000 MHz),

Controller 1/0/9 upstream 12 AdminState:UP OpState: UP
ofdma mode enabled
Channel Freq Range 28.500 MHz to 69.500 MHz
Channel Subcarrier Index Range Cfg: 148, 1787 Op: 148, 1787
Channel SC0 Freq Cfg: 24.800 MHz Op: 24.800 MHz
#Excl bands: 3
( 0, 147), ( 608, 776), (1788, 4095),
#Unused bands: 3
( 596, 607), (1001, 1088), (1777, 1787),

```

## Override OFDMA Profile Per Channel

It is possible to override the modulation and pilot pattern used by a particular IUC on a given OFDMA channel as shown with the command below.

```

enable
configure terminal
controller Upstream-Cable slot/subslot/port
us-channel id data-iuc id band start-value end-value modulation value pilot-pattern
value

```

Here is a configuration example:

```

Router# enable
Router# configure terminal
Router(config)# controller Upstream-Cable 1/0/2
Router(config-controller)# us-channel 12 docsis-mode ofdma
Router(config-controller)# us-channel 12 subcarrier-spacing 25KHz
Router(config-controller)# us-channel 12 modulation-profile 423

```

```
Router(config-controller)# us-channel 12 frequency-range 28000000 70000000
Router(config-controller)# us-channel 12 cyclic-prefix 96 roll-off-period 64
Router(config-controller)# us-channel 12 symbols-per-frame 18
Router(config-controller)# us-channel 12 data-iuc 6 band 60000000 65000000 modulation 128-QAM
pilot-pattern 9
Router(config-controller)# no us-channel 12 shutdown
```



**Note** Override values will be removed from US channel when changing modulation profile, including when profile changes due to changes in subcarrier spacing.

From Cisco cBR Series Converged Broadband Router 16.12.1w and later, the limitation of one IUC override per IUC configuration no longer applies for cBR-8 I-CMTS controller implementations on the CBR-LC-8D31-16U31 line card and R-PHY implementations on CBR-LC-8D31-16U31, CBR-CCAP-LC-40G-R, and CBR-CCAP-LC-G2-R line cards. The OFDMA - 4 override zones per IUC feature increases the number of overrides that can be defined to four per IUC.

A maximum channel configuration would appear as below:

```
controller Upstream-Cable 1/0/0
us-channel 12 data-iuc 5 band 40500000 41500000 modulation 64-QAM pilot-pattern 8
us-channel 12 data-iuc 5 band 42000000 43500000 modulation 128-QAM pilot-pattern 8
us-channel 12 data-iuc 5 band 44000000 45500000 modulation 256-QAM pilot-pattern 8
us-channel 12 data-iuc 5 band 46000000 47500000 modulation 512-QAM pilot-pattern 8
us-channel 12 data-iuc 6 band 40500000 41500000 modulation 64-QAM pilot-pattern 8
us-channel 12 data-iuc 6 band 42000000 43500000 modulation 128-QAM pilot-pattern 8
us-channel 12 data-iuc 6 band 44000000 45500000 modulation 256-QAM pilot-pattern 8
us-channel 12 data-iuc 6 band 46000000 47500000 modulation 512-QAM pilot-pattern 8
us-channel 12 data-iuc 9 band 40500000 41500000 modulation 64-QAM pilot-pattern 8
us-channel 12 data-iuc 9 band 42000000 43500000 modulation 128-QAM pilot-pattern 8
us-channel 12 data-iuc 9 band 44000000 45500000 modulation 256-QAM pilot-pattern 8
us-channel 12 data-iuc 9 band 46000000 47500000 modulation 512-QAM pilot-pattern 8
us-channel 12 data-iuc 10 band 40500000 41500000 modulation 64-QAM pilot-pattern 8
us-channel 12 data-iuc 10 band 42000000 43500000 modulation 128-QAM pilot-pattern 8
us-channel 12 data-iuc 10 band 44000000 45500000 modulation 256-QAM pilot-pattern 8
us-channel 12 data-iuc 10 band 46000000 47500000 modulation 512-QAM pilot-pattern 8
us-channel 12 data-iuc 11 band 40500000 41500000 modulation 64-QAM pilot-pattern 8
us-channel 12 data-iuc 11 band 42000000 43500000 modulation 128-QAM pilot-pattern 8
us-channel 12 data-iuc 11 band 44000000 45500000 modulation 256-QAM pilot-pattern 8
us-channel 12 data-iuc 11 band 46000000 47500000 modulation 512-QAM pilot-pattern 8
us-channel 12 data-iuc 12 band 40500000 41500000 modulation 64-QAM pilot-pattern 8
us-channel 12 data-iuc 12 band 42000000 43500000 modulation 128-QAM pilot-pattern 8
us-channel 12 data-iuc 12 band 44000000 45500000 modulation 256-QAM pilot-pattern 8
us-channel 12 data-iuc 12 band 46000000 47500000 modulation 512-QAM pilot-pattern 8
us-channel 12 data-iuc 13 band 40500000 41500000 modulation 64-QAM pilot-pattern 8
us-channel 12 data-iuc 13 band 42000000 43500000 modulation 128-QAM pilot-pattern 8
us-channel 12 data-iuc 13 band 44000000 45500000 modulation 256-QAM pilot-pattern 8
us-channel 12 data-iuc 13 band 46000000 47500000 modulation 512-QAM pilot-pattern 8
```

This allows nine modulation zones per profile across the channel. So, for example, for a modem using IUC 5, the channel modulation would be as follows:

```
router# show controller Upstream-Cable 1/0/0 us-channel 12 cdm-ump | beg Rang
Ranging profile:
IUC 3, preamble_len 256, sc mode 25KHz active_sc 64 guard_sc 0
IUC 4, preamble_len 192, sc mode 25KHz active_sc 192 guard_sc 0
Calculated Data burst profile:
  IUC  Group  Bit      Pilot  Start  Consec
      Loading  Pattern Mslot  Mslot
```

```

5      0      1024-QAM      8      0      24
5      1        64-QAM      8      25      1
5      2      1024-QAM      8      27      1
5      3      128-QAM      8      29      2
5      4      1024-QAM      8      32      1
5      5      256-QAM      8      34      2
5      6      1024-QAM      8      37      1
5      7      512-QAM      8      39      2
5      8      1024-QAM      8      42      42
...

```

**Note**

- All subcarriers within a single OFDMA minislot must be assigned the same modulation order. Different modulation orders cannot be assigned to different subcarriers within the same minislot.
- If a modulation override configuration is applied that places the frequency start and/or end within the middle of a minislot, the entire minislot will receive the override configuration.
- If two adjacent modulation overrides overlap the same minislot, the minislot receives the modulation configuration of the last override configuration. In most cases this will be the higher frequency override modulation.
- For the RPHY cards, the OFDMA - 4 override zones per IUC enhancement is supported with all RPD types that support OFDMA.

## Verifying Override Configuration

To display the override configuration, use the **show controllers upstream-Cable us-channel** command as shown in the example below:

```

Router# show controllers upstream-Cable 1/0/2 us-channel 12
.....
Modulation Profile (ID 423, Subcarrier Spacing 25KHz)
  IUC type  Cfg  Act  Preamble Bit      Pilot
           subc subc Symbols Loading Pattern
  3 (IR)    64   64    4      -      -
  4 (FR)   128  128    1      -      -
  6 (data)  -    -    -    1024-QAM  8
 10 (data)  -    -    -    512-QAM   8
 11 (data)  -    -    -    256-QAM   8
 12 (data)  -    -    -    128-QAM   9
 13 (data)  -    -    -    64-QAM    9

Overwrite Data Profile:
  IUC  Start      End      Start  End  Bit      Pilot
      Freq (MHz)  Freq (MHz)  Subc   Subc  Loading  Pattern
  6    60.0       65.0     1408  1608  128-QAM  9

Calculated Data burst profile:
  IUC  Group  Bit      Pilot  Start  Consec
      Loading  Pattern  Mslot  Mslot
  6    0    1024-QAM  8      0      61
  6    1    128-QAM  9      62     11
  6    2    1024-QAM  8      74     10
 10    0    512-QAM  8      0      84
 11    0    256-QAM  8      0      84
 12    0    128-QAM  9      0      84
 13    0    64-QAM   9      0      84
.....

```

## Apply OFDMA Upstream To Cable Interface

To associate upstream channels with a MAC domain and configure upstream bonding, follow the steps below:

```
enable
configure terminal
interface Cable slot/subslot/interface
cable upstream bonding-group id
upstream id
attributes value
cable bundle id
```

Here is a configuration example:

```
Router# enable
Router# configure terminal
Router(config)# interface Cable 1/0/4
Router(config-if)# downstream Integrated-Cable 1/0/4 rf-channel 0
Router(config-if)# downstream Integrated-Cable 1/0/4 rf-channel 16
Router(config-if)# upstream 0 Upstream-Cable 1/0/0 us-channel 0
Router(config-if)# upstream 1 Upstream-Cable 1/0/0 us-channel 1
Router(config-if)# upstream 2 Upstream-Cable 1/0/0 us-channel 2
Router(config-if)# upstream 3 Upstream-Cable 1/0/0 us-channel 3
Router(config-if)# upstream 6 Upstream-Cable 1/0/0 us-channel 12
Router(config-if)# cable upstream bonding-group 1
Router(config-upstream-bonding)# upstream 0
Router(config-upstream-bonding)# upstream 1
Router(config-upstream-bonding)# upstream 2
Router(config-upstream-bonding)# upstream 3
Router(config-upstream-bonding)# attributes 80000000
Router(config-upstream-bonding)# exit
Router(config-if)# cable upstream bonding-group 2
Router(config-upstream-bonding)# upstream 0
Router(config-upstream-bonding)# upstream 1
Router(config-upstream-bonding)# upstream 2
Router(config-upstream-bonding)# upstream 3
Router(config-upstream-bonding)# upstream 6
Router(config-upstream-bonding)# attributes 80000000
Router(config-upstream-bonding)# exit
Router(config-if)# cable bundle 1
```

## Determine DOCSIS 3.1 Cable Modems and the Cable Modems Using OFDMA Upstreams

To display the DOCSIS 3.1 cable modem, use the `show cable modem docsis version d31-capable` command as shown in the example below:

```
Router# show cable modem docsis version d31-capable
MAC Address      I/F                MAC                Reg Oper DSxUS DS  RCC  US
                  I/F                State              Ver Ver   OFDM ID  OFDMA
4800.33ea.7012  C1/0/0/UB         w-online(pt)       3.1 3.1  33x4  1   5    1
203d.66ae.4169  C1/0/0/UB         w-online(pt)       3.1 3.1  33x4  1   5    1
```

To display DOCSIS PHY layer information for the cable modem, use the **show cable modem phy** command as shown in the example below:

```
Router# show cable modem 5039.5584.5bbe phy
MAC Address      I/F          Sid  USPwr  USMER  Timing  DSPwr  DSMER  Mode  DOCSIS
                (dBmV)      (SNR)  Offset (dBmV) (SNR)  (dB)   (dB)   Prov
                (dB)
5039.5584.5bbe C1/0/0/U0  15   38.75  ----- 2282  0.00  ----- ofdma  1.1
```

To display the cable modem using OFDMA upstream, use the **show cable modem phy** command as shown in the example below:

```
Router# show cable modem phy | include ofdma
5039.5584.5bbe C1/0/0/U0  15   38.75  ----- 2282  0.00  ----- ofdma  1.1
0895.2a9b.26f1 C1/0/0/U0  16   28.00  ----- 2146  0.00  ----- ofdma  1.1
```

To display the OFDMA channel capacity and utilization, use the **show interface cable mac-scheduler** command as shown in the example below:

```
Router# show interfaces cable 1/0/2 mac-scheduler 6
DOCSIS 1.1 MAC scheduler for Cable1/0/2/U6 : rate 279807192
Max potential performance for each configured IUC type
IUC: 6      rate: 279807192
IUC: 10     rate: 263104848
IUC: 11     rate: 233779840
IUC: 12     rate: 203019328
IUC: 13     rate: 173899376
wfq:None
us_balance:OFF
dpon_mode:OFF
fairness:OFF
Queue[Rng Polls] flows 0
Queue[CIR Grants] flows 0
Queue[BE(07) Grants] flows 0
Queue[BE(06) Grants] flows 0
Queue[BE(05) Grants] flows 0
Queue[BE(04) Grants] flows 0
Queue[BE(03) Grants] flows 0
Queue[BE(02) Grants] flows 0
Queue[BE(01) Grants] flows 0
Queue[BE(00) Grants] flows 0
Req Slots 38510548
Req/Data Slots 1275
Init Mtn Slots 47832
Stn Mtn Slots 0
IUC 5 Slots 0
IUC 6 Slots 6378
IUC 9 Slots 0
IUC 10 Slots 254923830
IUC 11 Slots 220
IUC 12 Slots 4006
IUC 13 Slots 251213508
Avg upstream channel utilization : 0%
Avg upstream channel utilization in 30 sec : 0%
Avg percent contention slots : 96%
Avg percent initial ranging slots : 0%
Avg percent minislots lost on late MAPs : 0%

MAP TSS: lch_state 10, init_retries 0
         late_initial_maps 0, late_ucd_maps 0
         mac-phy tss errors 0, missed ccc 0
```



## Verifying DOCSIS 3.1 Upstream OFDMA channel bonding across DOCSIS 3.0 ATDMA channels

Starting from Cisco IOS XE Everest 16.6.1 release, DOCSIS 3.1 Upstream OFDMA channel can be bonded with DOCSIS 3.0 ATDMA channel. If the user wants to utilize non-best effort flows, it is recommended to bond the OFDMA channel with one or more ATDMA channels. But be aware that in Cisco IOS XE Everest 16.6.1 release, a maximum of 1 OFDMA channel and 4 ATDMA channels can be bonded together.

Below is an output example showing the bonding group 8 has both OFDMA (channel 12) and ATDMA channels (channel 0, 1, 2, 3).

```
interface Cable6/0/0
downstream Integrated-Cable 6/0/0 rf-channel 1
downstream Integrated-Cable 6/0/0 rf-channel 158
upstream 0 Upstream-Cable 6/0/0 us-channel 0
upstream 1 Upstream-Cable 6/0/0 us-channel 1
upstream 2 Upstream-Cable 6/0/0 us-channel 2
upstream 3 Upstream-Cable 6/0/0 us-channel 3
upstream 6 Upstream-Cable 6/0/0 us-channel 12
cable upstream bonding-group 1
    upstream 0
    upstream 1
    upstream 2
    upstream 3
    attributes 80000000
cable upstream bonding-group 8
    upstream 0
    upstream 1
    upstream 2
    upstream 3
    upstream 6
    attributes 80000000
cable bundle 1
cable privacy accept-self-signed-certificate
end
```

## Display the OFDMA Performance Statistics

Feature History

**Table 138: Feature History**

| Feature Name                                               | Release Information            | Feature Description                                                                                                                                                             |
|------------------------------------------------------------|--------------------------------|---------------------------------------------------------------------------------------------------------------------------------------------------------------------------------|
| RPHY support for show cable upstream ofdma mer-fec command | Cisco IOS XE Bengaluru 17.6.1x | This feature introduces the command <b>show cable upstream ofdma mer-fec</b> in Remote PHY deployment to get the channel performance statistics for the upstream OFDMA channel. |

| Feature Name                                               | Release Information            | Feature Description                                                                                                                                                             |
|------------------------------------------------------------|--------------------------------|---------------------------------------------------------------------------------------------------------------------------------------------------------------------------------|
| RPHY support for show cable upstream ofdma mer-fec command | Cisco IOS XE Bengaluru 17.6.1x | This feature introduces the command <b>show cable upstream ofdma mer-fec</b> in Remote PHY deployment to get the channel performance statistics for the upstream OFDMA channel. |

To display the OFDMA channel performance statistics at chassis level, use the **show cable upstream ofdma mer-fec** command as shown in the example below:

```

Router#show cable upstream ofdma mer-fec
Upstream:IUC          MER (dB)      TotalFecCW      CorrectedFecCW
UncorrFecCW          UncorrCW% MD:upstream
UC1/0/0:U12:IR      0.00         0                0                0
0.0                  Ca1/0/0:u6
UC1/0/0:U12:FR      0.00         0                0                0
0.0                  Ca1/0/0:u6
UC1/0/0:U12:IUC5    43.50        551758          161625           199
0.188               Ca1/0/0:u6
UC1/0/0:U12:IUC6    0.00         0                0                0
0.0                  Ca1/0/0:u6
UC1/0/0:U12:IUC9    35.50        222              193               0
0.0                  Ca1/0/0:u6
UC1/0/0:U12:IUC10   0.00         0                0                0
0.0                  Ca1/0/0:u6
UC1/0/0:U12:IUC11   0.00         0                0                0
0.0                  Ca1/0/0:u6
UC1/0/0:U12:IUC12   0.00         0                0                0
0.0                  Ca1/0/0:u6
UC1/0/0:U12:IUC13   43.50        107              0                 0
0.0                  Ca1/0/0:u6
UC1/0/0:U13:IR      0.00         0                0                0
0.0                  Ca1/0/0:u7
UC1/0/0:U13:FR      0.00         0                0                0
0.0                  Ca1/0/0:u7
UC1/0/0:U13:IUC5    45.70        545911          14257            1153
0.100               Ca1/0/0:u7
UC1/0/0:U13:IUC6    0.00         0                0                0
0.0                  Ca1/0/0:u7
UC1/0/0:U13:IUC9    0.00         0                0                0
0.0                  Ca1/0/0:u7
UC1/0/0:U13:IUC10   0.00         0                0                0
0.0                  Ca1/0/0:u7
UC1/0/0:U13:IUC11   0.00         0                0                0
0.0                  Ca1/0/0:u7
UC1/0/0:U13:IUC12   0.00         0                0                0
0.0                  Ca1/0/0:u7
UC1/0/0:U13:IUC13   45.70        85               0                 0
0.0                  Ca1/0/0:u7
UC9/0/0:U12:IR      0.00         0                0                0
0.0                  Ca9/0/0:u6
UC9/0/0:U12:FR      0.00         0                0                0
0.0                  Ca9/0/0:u6
UC9/0/0:U12:IUC5    46.50        552047          1779              0
0.0                  Ca9/0/0:u6
UC9/0/0:U12:IUC6    0.00         0                0                0
0.0                  Ca9/0/0:u6
UC9/0/0:U12:IUC9    0.00         0                0                0
0.0                  Ca9/0/0:u6
UC9/0/0:U12:IUC10   0.00         0                0                0
0.0                  Ca9/0/0:u6

```

|                   |       |             |        |     |
|-------------------|-------|-------------|--------|-----|
|                   | 0.0   | Ca9/0/0:u6  |        |     |
| UC9/0/0:U12:IUC11 | 0.00  | 0           | 0      | 0   |
|                   | 0.0   | Ca9/0/0:u6  |        |     |
| UC9/0/0:U12:IUC12 | 0.00  | 0           | 0      | 0   |
|                   | 0.0   | Ca9/0/0:u6  |        |     |
| UC9/0/0:U12:IUC13 | 47.70 | 155         | 0      | 0   |
|                   | 0.0   | Ca9/0/0:u6  |        |     |
| UC9/0/1:U12:IR    | 0.00  | 0           | 0      | 0   |
|                   | 0.0   | Ca9/0/1:u6  |        |     |
| UC9/0/1:U12:FR    | 0.00  | 0           | 0      | 0   |
|                   | 0.0   | Ca9/0/1:u6  |        |     |
| UC9/0/1:U12:IUC5  | 46.00 | 552906      | 6353   | 0   |
|                   | 0.0   | Ca9/0/1:u6  |        |     |
| UC9/0/1:U12:IUC6  | 0.00  | 0           | 0      | 0   |
|                   | 0.0   | Ca9/0/1:u6  |        |     |
| UC9/0/1:U12:IUC9  | 0.00  | 0           | 0      | 0   |
|                   | 0.0   | Ca9/0/1:u6  |        |     |
| UC9/0/1:U12:IUC10 | 0.00  | 0           | 0      | 0   |
|                   | 0.0   | Ca9/0/1:u6  |        |     |
| UC9/0/1:U12:IUC11 | 0.00  | 0           | 0      | 0   |
|                   | 0.0   | Ca9/0/1:u6  |        |     |
| UC9/0/1:U12:IUC12 | 0.00  | 0           | 0      | 0   |
|                   | 0.0   | Ca9/0/1:u6  |        |     |
| UC9/0/1:U12:IUC13 | 43.70 | 58          | 0      | 0   |
|                   | 0.0   | Ca9/0/1:u6  |        |     |
| UC9/0/2:U12:IR    | 0.00  | 0           | 0      | 0   |
|                   | 0.0   | Ca9/0/2:u12 |        |     |
| UC9/0/2:U12:FR    | 0.00  | 0           | 0      | 0   |
|                   | 0.0   | Ca9/0/2:u12 |        |     |
| UC9/0/2:U12:IUC5  | 42.20 | 552542      | 194533 | 264 |
|                   | 0.32  | Ca9/0/2:u12 |        |     |
| UC9/0/2:U12:IUC6  | 41.70 | 55          | 0      | 0   |
|                   | 0.0   | Ca9/0/2:u12 |        |     |
| UC9/0/2:U12:IUC9  | 0.00  | 0           | 0      | 0   |
|                   | 0.0   | Ca9/0/2:u12 |        |     |
| UC9/0/2:U12:IUC10 | 0.00  | 0           | 0      | 0   |
|                   | 0.0   | Ca9/0/2:u12 |        |     |
| UC9/0/2:U12:IUC11 | 0.00  | 0           | 0      | 0   |
|                   | 0.0   | Ca9/0/2:u12 |        |     |
| UC9/0/2:U12:IUC12 | 0.00  | 0           | 0      | 0   |
|                   | 0.0   | Ca9/0/2:u12 |        |     |
| UC9/0/2:U12:IUC13 | 42.00 | 105         | 0      | 0   |
|                   | 0.0   | Ca9/0/2:u12 |        |     |
| UC9/0/2:U13:IR    | 0.00  | 0           | 0      | 0   |
|                   | 0.0   | Ca9/0/2:u13 |        |     |
| UC9/0/2:U13:FR    | 0.00  | 0           | 0      | 0   |
|                   | 0.0   | Ca9/0/2:u13 |        |     |
| UC9/0/2:U13:IUC5  | 0.00  | 0           | 0      | 0   |
|                   | 0.0   | Ca9/0/2:u13 |        |     |
| UC9/0/2:U13:IUC6  | 40.20 | 526632      | 40107  | 3   |
|                   | 0.44  | Ca9/0/2:u13 |        |     |
| UC9/0/2:U13:IUC9  | 0.00  | 0           | 0      | 0   |
|                   | 0.0   | Ca9/0/2:u13 |        |     |
| UC9/0/2:U13:IUC10 | 0.00  | 0           | 0      | 0   |
|                   | 0.0   | Ca9/0/2:u13 |        |     |
| UC9/0/2:U13:IUC11 | 0.00  | 0           | 0      | 0   |
|                   | 0.0   | Ca9/0/2:u13 |        |     |
| UC9/0/2:U13:IUC12 | 0.00  | 0           | 0      | 0   |
|                   | 0.0   | Ca9/0/2:u13 |        |     |
| UC9/0/2:U13:IUC13 | 43.00 | 18          | 0      | 0   |
|                   | 0.0   | Ca9/0/2:u13 |        |     |

## Display the OFDMA Performance Statistics

To display the channel specific OFDMA performance statistics, use the **show controllers upstream-cable** command as shown in the example below:

```
Router#show controllers upstream-Cable 9/0/0 us-channel 12
Controller RPD US Port List:
```

```
DevID  RPD ID          US Port  I/F      Name
-----
  0     70b3.1791.4278    0       Te9/1/0  LC9_RPD1_3x6_RACK4

rpd_id          upstream-Port  mac_idx  mac_chidx  discontinuityTime  pollCnt
-----
70b3.1791.4278  0              336      7          Mon Jan 17 22:38:54 2022 2327

IUC IUC   FEC          FEC Post          FEC Post          RxMer Scheduled
    Type Tot. CWs          NoPreamble          Error              Avg  Grants
    Bursts          Pass CWs            Fail CWs           

3  IR     0              0                 0                 00.00 -
   -
4  FR     0              0                 0                 00.00 -
   -
5  (data) 552083        1779             0                 46.50 299078
   0          -1             -1
6  (data) 0              0                 0                 00.00 0
   0          -1             -1
9  (data) 0              0                 0                 00.00 0
   0          -1             -1
10 (data) 0              0                 0                 00.00 0
   0          -1             -1
11 (data) 0              0                 0                 00.00 0
   0          -1             -1
12 (data) 0              0                 0                 00.00 0
   0          -1             -1
13 (data) 155           0                 0                 47.70 132
   0          -1             -1
```

```
USPHY OFDMA support: FULL
```

```
Controller 9/0/0 upstream 12  AdminState:UP OpState: UP
ofdma mode enabled
Channel Freq Range 60.500 MHz to 79.500 MHz
Channel Subcarrier Index Range Cfg: 148, 907 Op: 148, 907
Channel SC0 Freq Cfg: 56.800 MHz Op: 56.800 MHz
#Excl bands: 2
( 0, 147), ( 908, 4095),
#Unused bands: 1
( 900, 907),
Cyclic Prefix Size 96, Rolloff Period Size 0
Subcarrier Spacing 25KHz, Symbols Per Frame 9 Subcarrier Per Minislot: 16
```

```
Modulation Profile (ID 450, Subcarrier Spacing 25KHz)
```

| IUC | type   | Cfg  | Act  | Preamble | Bit      | Pilot   |
|-----|--------|------|------|----------|----------|---------|
|     |        | subc | subc | Symbols  | Loading  | Pattern |
| 3   | (IR)   | 64   | 64   | 4        | -        | -       |
| 4   | (FR)   | 256  | 256  | 1        | -        | -       |
| 5   | (data) | -    | -    | -        | 4096-QAM | 14      |
| 6   | (data) | -    | -    | -        | 2048-QAM | 12      |
| 9   | (data) | -    | -    | -        | 1024-QAM | 12      |
| 10  | (data) | -    | -    | -        | 512-QAM  | 12      |
| 11  | (data) | -    | -    | -        | 256-QAM  | 12      |
| 12  | (data) | -    | -    | -        | 128-QAM  | 12      |

```

13 (data) - - - 64-QAM 12
Calculated Data burst profile:
IUC Group Bit Pilot Start Consec
Loading Pattern Mslot Mslot
5 0 4096-QAM 14 0 46
6 0 2048-QAM 12 0 46
9 0 1024-QAM 12 0 46
10 0 512-QAM 12 0 46
11 0 256-QAM 12 0 46
12 0 128-QAM 12 0 46
13 0 64-QAM 12 0 46

#Total mslots:47 #Fine Rng capable:32 #Initial Rng capable:44
Initial Rng - Freq 0.000MHz mslotOffset:15 #mslot in frame:4
Minislot mapping: mslot#(start_sc start_freq(Mhz) end_sc end_freq(Mhz) peer_scqam
mslot type(E-Edge; B-Body; S-Share with SCQAM;
I-Initial rng capable; F-Fine rng capable)
(next Fine Rng capable minislot if current is not capable))
0 ( 148, 60.500, 163, 60.875, EIF ( - )), 1 ( 164, 60.900, 179, 61.275, BIF
( - )),
2 ( 180, 61.300, 195, 61.675, BIF ( - )), 3 ( 196, 61.700, 211, 62.075, BIF
( - )),
4 ( 212, 62.100, 227, 62.475, BIF ( - )), 5 ( 228, 62.500, 243, 62.875, BIF
( - )),
6 ( 244, 62.900, 259, 63.275, BIF ( - )), 7 ( 260, 63.300, 275, 63.675, BIF
( - )),
8 ( 276, 63.700, 291, 64.075, BIF ( - )), 9 ( 292, 64.100, 307, 64.475, BIF
( - )),
10 ( 308, 64.500, 323, 64.875, BIF ( - )), 11 ( 324, 64.900, 339, 65.275, BIF
( - )),
12 ( 340, 65.300, 355, 65.675, BIF ( - )), 13 ( 356, 65.700, 371, 66.075, BIF
( - )),
14 ( 372, 66.100, 387, 66.475, BIF ( - )), 15 ( 388, 66.500, 403, 66.875, BIF
( - )),
16 ( 404, 66.900, 419, 67.275, BIF ( - )), 17 ( 420, 67.300, 435, 67.675, BIF
( - )),
18 ( 436, 67.700, 451, 68.075, BIF ( - )), 19 ( 452, 68.100, 467, 68.475, BIF
( - )),
20 ( 468, 68.500, 483, 68.875, BIF ( - )), 21 ( 484, 68.900, 499, 69.275, BIF
( - )),
22 ( 500, 69.300, 515, 69.675, BIF ( - )), 23 ( 516, 69.700, 531, 70.075, BIF
( - )),
24 ( 532, 70.100, 547, 70.475, BIF ( - )), 25 ( 548, 70.500, 563, 70.875, BIF
( - )),
26 ( 564, 70.900, 579, 71.275, BIF ( - )), 27 ( 580, 71.300, 595, 71.675, BIF
( - )),
28 ( 596, 71.700, 611, 72.075, BIF ( - )), 29 ( 612, 72.100, 627, 72.475, BIF
( - )),
30 ( 628, 72.500, 643, 72.875, BIF ( - )), 31 ( 644, 72.900, 659, 73.275, BIF
( - )),
32 ( 660, 73.300, 675, 73.675, BI ( 0 )), 33 ( 676, 73.700, 691, 74.075, BI
( 0 )),
34 ( 692, 74.100, 707, 74.475, BI ( 0 )), 35 ( 708, 74.500, 723, 74.875, BI
( 0 )),
36 ( 724, 74.900, 739, 75.275, BI ( 0 )), 37 ( 740, 75.300, 755, 75.675, BI
( 0 )),
38 ( 756, 75.700, 771, 76.075, BI ( 0 )), 39 ( 772, 76.100, 787, 76.475, BI
( 0 )),
40 ( 788, 76.500, 803, 76.875, BI ( 0 )), 41 ( 804, 76.900, 819, 77.275, BI
( 0 )),
42 ( 820, 77.300, 835, 77.675, BI ( 0 )), 43 ( 836, 77.700, 851, 78.075, BI
( 0 )),
44 ( 852, 78.100, 867, 78.475, B ( 0 )), 45 ( 868, 78.500, 883, 78.875, B
( 0 )),

```

```

46 ( 884, 78.900, 899, 79.275, B (0 ) ),

Mapped to connector 0 and receiver 256
Bind to Cable9/0/0 US6
US phy MER(SNR)_estimate - Unknown
Spectrum Group is unassigned
Nominal Input Power Level 10 dBmV

UCD procedures on lch 0 ucd-proxy-timeout (0 )
UCD ucd-proxy-wrong-ack (1 )

```

## Feature Information for DOCSIS 3.1 OFDMA Channel Configuration

Use Cisco Feature Navigator to find information about the platform support and software image support. Cisco Feature Navigator enables you to determine which software images support a specific software release, feature set, or platform. To access Cisco Feature Navigator, go to the <https://cfnng.cisco.com/> link. An account on the Cisco.com page is not required.



**Note** The following table lists the software release in which a given feature is introduced. Unless noted otherwise, subsequent releases of that software release train also support that feature.

**Table 139: Feature Information for DOCSIS 3.1 OFDMA Channel Configuration**

| Feature Name                                                         | Releases                        | Feature Information                                                              |
|----------------------------------------------------------------------|---------------------------------|----------------------------------------------------------------------------------|
| DOCSIS 3.1 US 16 OFDMA channel support per line card                 | Cisco IOS XE Fuji 16.7.1        | This feature was integrated on the Cisco cBR Series Converged Broadband Routers. |
| DOCSIS 3.1 US OFDMA channel bonding across DOCSIS 3.0 ATDMA channels | Cisco IOS XE Fuji 16.7.1        | This feature was integrated on the Cisco cBR Series Converged Broadband Routers. |
| TaFDM OFDMA Support                                                  | Cisco IOS XE Fuji 16.7.1        | This feature was integrated on the Cisco cBR Series Converged Broadband Routers. |
| 204 Mhz Maximum Frequency OFDMA Support                              | Cisco IOS XE Fuji 16.8.1        | This feature was integrated on the Cisco cBR Series Converged Broadband Routers. |
| Remote PHY DOCSIS 3.1 OFDMA Channel Configuration                    | Cisco IOS XE Fuji 16.9.1        | This feature was integrated on the Cisco cBR Series Converged Broadband Routers. |
| iCCAP 2 OFDMA Channels per port                                      | Cisco IOS XE Gibraltar 16.10.1c | This feature was integrated on the Cisco cBR Series Converged Broadband Routers. |
| Remote PHY DOCSIS 3.1 OFDMA LCHA & LCPR                              | Cisco IOS XE Gibraltar 16.10.1c | This feature was integrated on the Cisco cBR Series Converged Broadband Routers. |
| OFDMA - 4 override zones per IUC                                     | Cisco IOS XE Gibraltar 16.12.1w | This feature was integrated on the Cisco cBR Series Converged Broadband Routers. |



## CHAPTER 41

# OFDMA OUDP Leak Detection Configuration

This document describes how to configure OFDMA OUDP leak detection on the Cisco cBR Series Converged Broadband Router.

- [OUDP Leakage Detection](#), on page 675
- [Methods to Configure OUDP Leak Detection](#), on page 676
- [Supported Line Cards](#), on page 676
- [OUDP Leakage Detection Test Sessions](#), on page 676
- [OUDP Parent Test Sessions](#), on page 679
- [OUDP Child Test Sessions](#), on page 679
- [Persistent OUDP Test Sessions](#), on page 681
- [OUDP Late Modem Joining](#), on page 682
- [OUDP System Boot Holdoff](#), on page 683
- [OUDP Test Expiration](#), on page 683
- [OUDP Test Session High Availability](#), on page 683
- [EXEC Mode Command Summary](#), on page 684
- [Global Configuration Mode Command Summary](#), on page 687
- [Configuration Mode Command Summary](#), on page 687
- [OUDP Burst-Profile Sub-Mode Config CLI Commands](#), on page 688
- [Show OUDP Command Summary](#), on page 689
- [Related Show Command Summary](#), on page 690
- [Example: Configuration Command Mode](#), on page 690
- [Example: EXEC Command Mode](#), on page 691
- [Verifying the OUDP Session](#), on page 691
- [Example: Creating a Test Session on Selected Modems Using the EXEC Mode](#), on page 692
- [Specifications](#), on page 693
- [Recommendations for the OFDMA Burst Testing Channel Configuration](#), on page 693
- [Example: Channel Configuration for a Third-Party Leak Detector](#), on page 693
- [OUDP DOCS-LEAK-DETECT MIB](#), on page 694

## OUDP Leakage Detection

Cable operators can now measure cable signal leaks by initiating the Orthogonal Frequency-Division Multiple Access (OFDMA) Upstream Data Profile (OUDP) leakage test sessions on one or more upstream OFDMA channels simultaneously. OUDP test sessions are initiated using CLI commands in the config and exec modes.

These commands direct modems to generate a test burst, which enables operators to locate leaks in the Federal Aviation Administration (FAA) frequency range above 100MHz. Operators use handheld or vehicle-based devices to detect leaks.

### Importance of Detecting Signal or RF Leakage

Cable operators desire to increase upstream bandwidth by utilizing high split diplexers. These diplexers increase the upstream frequency range to 204 MHz, which allows the cable modem to transmit in the Federal Aviation Administration (FAA) frequency range above 100MHz. This means that the 118 MHz to 136.975 MHz aeronautical band now overlaps the upstream cable frequency range. When Radio Frequency (RF) cables are damaged or cable faults such as ground failures or shielding failures occur, it may cause electromagnetic energy to escape from the transmission line into the environment. This energy is referred to as RF leakage. Any cable signal leak may interfere with the FAA frequency range. Rectifying upstream RF leakage ensures compliance with FCC guidelines.

## Methods to Configure OUDP Leak Detection

There are two ways to configure the burst sessions on CBR-8 routers:

- In the Configuration mode, you can configure one or more OUDP burst profiles, and associate the burst profiles with persistent OUDP test schedules.
- In the Privileged Exec mode, you can execute commands to create a burst session, however, these commands are not persistent across reboots.

## Supported Line Cards

The OUDP leak detection feature is supported on the following line cards:

| First Supported Release | Supported Line Cards                                                                              |
|-------------------------|---------------------------------------------------------------------------------------------------|
| 17.9.1w                 | CBR-LC-8D31-16U31                                                                                 |
| 17.6.1z                 | <ul style="list-style-type: none"> <li>• CBR-CCAP-LC-40G-R</li> <li>• CBR-CCAP-LC-G2-R</li> </ul> |

## OUDP Leakage Detection Test Sessions

OUDP test sessions are created in the Exec CLI or Configuration mode and are maintained on the SUP and CLC line cards. A test session identifies a list of modems that will participate in the OUDP burst test, the frequency range to be tested, the transmit burst parameters, and the start and stop time of the test. Two types of OUDP test sessions are managed by the cBR-8, parent test sessions and child test sessions.

A parent test session is created on the SUP using Exec or Configuration CLI commands and is identified by a unique parent session Id. parent test sessions are set up to include the frequency range to be tested, the transmit burst parameters, and a cable modem mac-address list and/or an interface to be tested.



A child test session is created on the line card, has a child session Id that is unique to the slot and are associated with a parent test session. There can be 0, 1 or many child test sessions associated with a parent test session depending on the method used to identify the participating modem list. The child test sessions are set up with the minislots frequency range and transmit burst parameters corresponding to their parent test session. A unique child test session will be created for each OFDMA channel participating in the OUDP test.

All OUDP test sessions transition through a series of states as the test progresses.

| Status/State  | Description                                                                                                                                                                  |
|---------------|------------------------------------------------------------------------------------------------------------------------------------------------------------------------------|
| CONFIG        | Identifies a parent test session that is partially configured through Exec CLI commands.                                                                                     |
| PENDING       | Identifies a parent or child test session that is fully configured, either by Exec CLI or Configuration mode, and whose pretest setup time has not been reached yet.         |
| PRETEST_SETUP | Identifies a parent or child test session that has reached the pretest setup state. The pretest setup time is a configurable number of seconds prior to the test start time. |
| ACTIVE        | Identifies a parent or child test session that has reached its test session start time.                                                                                      |
| CLEANUP       | Identifies a parent or child test session that has reached its test session stop time, or has been manually stopped through the CLI.                                         |
| COMPLETE      | Identifies a parent or child test session that has ended. Per modem OUDP burst stats are retained in completed child test sessions.                                          |

The progression of an OUDP Test Session includes the following steps:

1. The Parent Test Session is fully set up on the SUP through the Exec CLI or Configuration commands.
2. At Pre-Test Setup time—a configurable time prior to the test start:



**Note** The default time is 1 minute.

- a. The parent test session is distributed to all cable line cards.
- b. The cable line cards determine whether they have any OFDMA channels that match the parent test parameters.
- c. The cable line cards create a unique child test session for each OFDMA channel with online D3.1 CMs based on the parent test parameters.
- d. The child test sessions are notified back to the SUP from the cable line card.
- e. Each participating CM is assigned a unique OUDP Test Session ID (SID).

- f. A DBC-REQ message is sent to each CM to set up its OUDP Test SID.
  - g. The US Scheduler receives the test parameters for Burst Duration, Burst Gap, and Cycle Time.
  - h. The US Scheduler receives the ordered list of SIDs to be scheduled for the OUDP test cycle.
3. At the start of the test, the US Scheduler begins granting on the OUDP Test SIDs.
  4. Modems respond to the grants by transmitting the OUDP Test packets as defined in the MULPI specification. Modem bursts are periodic based on the configured OUDP test cycle and always occur at a fixed time-offset from the start of a test cycle.
  5. Modem test bursts are received by the upstream PHY and processed by the upstream FPGA. The PHY and FPGA collect the stats for burst no energy, bursts received, and bytes received.
  6. Stats collection for each SID occurs periodically, every 10 seconds, on the cable line card and are forwarded to the SUP.
  7. The test continues until the test stop time is reached:
    - a. Final Stats collection occurs for each CM.
    - b. The US Scheduler SID list will be deleted.
    - c. The US Scheduler OUDP minislots assignments will be cleared.
    - d. Each modem will be sent the OUDP\_DISABLE\_SID to clear its OUDP Test SID.
    - e. The OUDP test SIDs will be deallocated and deactivated and returned to the SID pool.
  8. Test Session stats can be reviewed through CLI show commands.
  9. Test Sessions are manually deleted or deleted automatically at the specified Expiry age.

## OUDP Leakage Detection Test Procedure

### OUDP Leakage Detection Test Procedure

You can configure a OUDP leakage detection test with the following parameters:

- OFDMA channel parameters
- Subcarrier spacing
- Cyclic prefix
- Frequency of subcarrier 0
- Symbols per frame

The OUDP test commands are configured through exec CLI (test session) and config CLI (burst profile) and are used for the following actions:

1. Create an OUDP test session or burst profile.
2. Configure transmit burst duration, burst gap, and cycle gap or cycle-time.
3. Configure the frequency range of the OUDP test.

4. Assign modems to OUDP test through an upstream controller, MAC domain, or list of modem's MAC addresses.
5. Schedule a start time or end time for the OUDP test.

You can create a parent session through exec or config CLI and the child session is automatically created when the parent session is activated.

## OUDP Parent Test Sessions

An OUDP parent test session is a test session that is created on the SUP to run at a specific time, over a specific frequency range, using specific transmit burst parameters, and that includes a specific set of cable modems. When created using EXEC mode, the parent test session is not persistent. In other words, the Exec mode OUDP test session will be lost if the system is reloaded. To create a persistent OUDP test session the Configuration CLI mode should be used, and the configuration should be saved to startup-config.

A parent test session must include either a CM-List or an interface or both. The CM-List consists of a list of modem mac-addresses. The system supports a maximum of 400 mac-addresses in the CM-List. Mac-addresses included in the CM-List may be from a single slot/single OFDMA channel, or from several different slots on different OFDMA channels. Mac-addresses setup in the parent CM-List are not validated.

A parent test session may also include an interface. The interfaces supported include a mac-domain (for example Cable1/0/0), a controller (for example controller upstream-cable 1/0/4), or a controller channel (for example controller upstream-cable 1/0/4 us-channel 12). When both a CM-List and an interface are setup in a parent test session, the list of modems that will participate in the test will be the logical AND of the CM-List with the modems on the interface.

Multiple parent test sessions can be setup simultaneously. The cBR-8 will manage all parent test sessions appropriately based on their configured start and stop times. Parent test sessions are assigned Ids in the 1 – 9999 range. If a multiple parent test sessions exist that would otherwise include the same OFDMA channels and/or the same cable modems, the first parent test session to start will win. Subsequent overlapping parent test sessions will start on time, but will not include a child test session for an OFDMA channel that is already active in another parent test session.

Exec CLI commands are provided to manage parent test sessions. When commands like stop and delete are used on the parent test session, all related child test sessions will also be stopped and deleted.

When Exec CLIs are used to create a parent test session, the admin is allowed to choose the parent test session Id, which must be in the range 1-9999. When the cBR-8 restores persistent OUDP test sessions, it will create parent test sessions using the next available parent test session Id, starting from 1. Duplicate parent test session Ids are not allowed.

You can create a session by using the **cable oudp-leak-detect session-id <id> session create** command at the privileged EXEC mode. The specified ID is referred to as the parent ID.

## OUDP Child Test Sessions

The cBR-8 routers create child test sessions, automatically, as needed. The administrator cannot create the child test sessions directly. A child test session is created for each OFDMA channel that will be participating in an OUDP test. When the child test session is created, it is assigned a unique child session ID. Child session IDs are assigned a value that corresponds to the slot on which they originated.

| Slot | Child Session ID Range |
|------|------------------------|
| 0    | 100,000 – 109,999      |
| 1    | 10,000 – 19,999        |
| 2    | 20,000 – 29,999        |
| 3    | 30,000 – 39,999        |
| 6    | 60,000 – 69,999        |
| 7    | 70,000 – 79,999        |
| 8    | 80,000 – 89,999        |
| 9    | 90,000 – 99,99         |

For the child test session to be created, it must have at least one valid DOCSIS3.1 cable modem online and that modem must also be using the OFDMA channel.



**Note** If the modem is reporting the OFDMA channel in partial service, it still joins and participates in the OUDP test. Grants will be issued to the modem, but as long as the modem reports partial-service on the OFDMA channel, it is possible that the **BurstNoEnergyRx** stat is incremented.

When a child test session is created from a parent test session, the frequency range of the parent test session is translated into a frequency range aligned with the OFDMA channel minislots that are inclusive of the parent frequency range. Thus, the child test session detailed information may show a minislot frequency range larger than the parent test session frequency range.

The child test session also inherits the transmit burst parameters of the parent test session. These values should always be identical to the parent.

Child test sessions also contain CM-List and interface configuration details. The interface of a child test session will always be a controller upstream-cable us-channel particular to a single OFDMA channel. The CM-List of a child session will only include the cable modems particular to the OFDMA associated with the child test session. By default, cable modems of a child test session are assigned burst positions within the OUDP test cycle starting from position 0. However, an option **strict-cm-list** exists that enforces the parent CM-List position on the child test sessions. For example, when the **strict-cm-list** option is used, a modem in CM-List position 5 of the parent CM-List appears in position 5 of the corresponding child test session CM-List.



**Note** The **strict-cm-list** position should only be used if the exact time offset of the CM must be maintained within the OUDP test cycle. The use of this option can result in unused burst positions within the OUDP test.

Mac-addresses in the parent test session are validated as they are assigned to child test sessions. Mac-addresses in the CM-List that are invalid format, are not known on the system, are valid but the modem is offline, are not D3.1 cable modems, or are D3.1 cable modems that are not using an OFDMA channel will not participate in the OUDP test.

This show command output shows child sessions IDs and their associated parent ID:

| Parent | Child | Interface   | Modems | Status | Start-Time                  | Stop-Time |
|--------|-------|-------------|--------|--------|-----------------------------|-----------|
| 99     | -     | -           | 1      | ACTIVE | 2022-07-23,20:05:12.0,-5:00 | never     |
| 99     | 10006 | Ca1/0/0/U6  | 1      | ACTIVE | 2022-07-23,20:05:12.0,-5:00 | never     |
| 99     | 10008 | Ca1/0/2/U14 | 2      | ACTIVE | 2022-07-23,20:05:12.0,-5:00 | never     |
| 99     | 90007 | Ca9/0/0/U6  | 2      | ACTIVE | 2022-07-23,20:05:12.0,-5:00 | never     |
| 99     | 90008 | Ca9/0/1/U6  | 2      | ACTIVE | 2022-07-23,20:05:12.0,-5:00 | never     |
| 99     | 90009 | Ca9/0/30/U6 | 1      | ACTIVE | 2022-07-23,20:05:12.0,-5:00 | never     |
| 99     | 90010 | Ca9/0/31/U6 | 2      | ACTIVE | 2022-07-23,20:05:12.0,-5:00 | never     |

## Persistent OUDP Test Sessions

OUDP test sessions set up using the Configuration CLI mode are persistent and known as scheduled OUDP test sessions. The parameters and options for configuration mode are similar to the commands offered by the Exec CLI, except for the **cm-add** or **cm-delete** Exec commands. In configuration mode, the CM-List is loaded from a file located on the hard drive, bootflash, or usb IOS file systems.

There are two types of scheduled OUDP test sessions.

- Date-Time
- Recurring Weekday

Date-Time schedules are configured to start and stop at a specified calendar date-and-time. The format follows the OSSI specification for Date-And-Time Strings:

```
[YY]YY-[M]M-[D]D, [h]h:mm:ss.0, [+|-] [T]T:ZZ
```

Example: 2022-07-23,22:31:44.0,-5:00

In addition, Date-Time schedules support the option for start 'now' and stop 'never'. These options are useful to reestablish OUDP test sessions automatically after a system reload.

Recurring Weekday schedules allow the administrator to create a scheduled OUDP test session that runs on specific days of the week, and during specific times of the day. The time-of-day is specified using 24-hour military time, and is relative to the local timezone of the cBR-8. Upon completion, a Recurring Weekday test will be rescheduled to start on the next subsequent weekday at the configured start time.

Persistent OUDP test sessions are configured by first creating an OUDP Burst Profile. The burst profile includes the test session parameters for frequency range, transmit burst parameters, interface and/or CM-List. Each OUDP burst profile is assigned a unique ID, and multiple burst profiles are supported.

After the burst profile is configured, a scheduled OUDP test session can be configured. The OUDP schedule binds the burst profile ID to the Date-Time or Recurring Weekday schedule. A single OUDP burst profile may be configured under one or more OUDP schedules. When the OUDP burst profile and schedule configurations are complete, an OUDP parent test session is created and associated with the OUDP schedule. The assigned parent test session ID can be shown using the **show cable oudp-leak-detect schedules** command.

### CM-List Format

Configured OUDP test sessions may include a CM-List that is read from a file on harddisk, bootflash, or usb0 IOS file systems. The format rules for the file are as follows:

- File type is ASCII text.
- Enter one mac-address per line.
- Mac-addresses may be either **aaaa.bbbb.cccc** or **aa:bb:cc:dd:ee:ff** format.

- Blank lines are permitted.
- Comment lines are permitted and must start with # as the first character of the line.
- Comments or other characters should not follow MAC addresses.
- Include a <CR> after the final MAC address in the file.

### Example

```
#
##### This is an example OUDP CM-List file.#####

# C1/0/0
4800.33ef.00fa
4800.33ef.014a
4800.33ef.0142
4800.33ef.0b0e

# C1/0/2
1459.c0f8.5210
4800.33ef.0d6a
4800.33ee.ff9a
4800.33ea.70c2
4800.33ea.71ba
```

### CM-List Wildcard

The CM-List supports a wildcard mac-address. The wildcard mac-address is ffff.ffff.ffff. When this mac-address is included in the CM-List (either Exec or Config created), it matches all eligible cable modems during child test session creation.

The wildcard CM-List is the easiest method for starting an OUDP test session on the entire cBR-8. All D3.1 modems using an OFDMA channel that matches the OUDP frequency range will be assigned to a child test session and will participate in the OUDP test session.

## OUDP Late Modem Joining

The cBR-8 provides a feature for D3.1 modems to join an OUDP test session after the test session has started. Cable modems that are offline at the start of a test, but otherwise intended to participate in the OUDP test session, are added to the OUDP test session after they register, provided:

1. The modem mac-address is included in the CM-List of the parent test session.
2. The parent test session includes the interface of the OFDMA channel that the modem is using.

A test session configured with only a CM-List:

- Allows late modem joining for modems whose mac-addresses are listed within the CM-List.
- Allows all eligible modems that contain the wildcard mac address ffff.ffff.ffff to join the test session.

A test session configured with only an interface will allow late modem joining only for new modems on the specified interface.

While an OUDP test session is active, the OUDP process will periodically check every 15 minutes to determine if new modems can be added to an existing test.

## OUDP System Boot Holdoff

The cBR-8 router provides a feature for OUDP, where persistent OUDP test sessions will not be started until the system is up and the OFDMA channel reach UP state with cable modems online. The amount of time to wait after system boot-up is configurable. The persistent test sessions restored from startup-config will not be distributed to the cable line cards and child test sessions will not be created until the system-boot-holdoff time has elapsed.



---

**Note** The default **system-boot-holdoff** time is 15 minutes.

---

## OUDP Test Expiration

The cBR-8 retains OUDP test sessions for a period of time after they have reached the COMPLETE state. This allows time for the administrator to retrieve CM burst statistics for post processing and analysis. However, OUDP test sessions occupy memory on both the SUP and cable line card processors, so they should be deleted in a timely fashion. To facilitate their deletion, the cBR-8 automatically deletes expired OUDP test sessions when they have aged beyond the globally configured expire-age. By default this is 3 days, and the value is configurable from 1 to 7 days.

## OUDP Test Session High Availability

The cBR-8 supports the high availability feature for OUDP leakage testing.

Supervisor High Availability (SUP-HA) is supported, with child test session CM burst stats restored to the newly active SUP shortly after switchover.

Line Card High Availability (LCHA) is also supported for OUDP leakage testing. After LCHA switchover, CM burst stats will continue to be collected and reported up to the SUP.

CM burst stats are reported periodically every 10 seconds, so it may take up to 20 seconds after switchover for stats to begin incrementing.

## MIB Considerations

- **SUPHA**—All the test session values are calculated on the line card without interruption. The configuration across a switchover is maintained and after the leakage detection process restarts.

For a high availability environment, the MIBs are available only after the newly active SUPHA initialization completes with the SNMP engine.

- **LCHA**—The test session values are available only after the successful initialization of the newly active line card's stats engine.
- **LCPR**—For a High Availability environment, all the test session values are calculated on the line card without interruption.

The MIB entries are available after the process restart.

## EXEC Mode Command Summary

| EXEC CLI Command                                                                                                              | Description                                                                                                                                                                                                                                            |
|-------------------------------------------------------------------------------------------------------------------------------|--------------------------------------------------------------------------------------------------------------------------------------------------------------------------------------------------------------------------------------------------------|
| <b>cable oudp-leak-detect session-id &lt;parent id&gt;<br/>session create</b>                                                 | Creates a new OUDP Parent test session assigning a new parent session ID.                                                                                                                                                                              |
| <b>cable oudp-leak-detect session-id &lt;parent id&gt;<br/>session delete</b>                                                 | Deletes the specified OUDP Parent test session and frees the parent session ID and all children sessions and IDs.                                                                                                                                      |
| <b>cable oudp-leak-detect session-id &lt;parent id&gt;<br/>session stop</b>                                                   | Stops the specified OUDP test session in ACTIVE state. Stopping a parent session stops all child sessions.                                                                                                                                             |
| <b>cable oudp-leak-detect session-id &lt;parent id&gt;<br/>session reset</b>                                                  | Resets an OUDP Parent Test Session. Removes all child sessions, deletes all stats, clears the parent start and stop time, and sets the session status back to CONFIGURING. This CLI is intended to allow a COMPLETED parent test session to be reused. |
| <b>cable oudp-leak-detect session-id &lt;parent id&gt; start<br/>datetime &lt;datetime&gt; stop datetime &lt;datetime&gt;</b> | Date-and-Time Format<br>[YY]YY-[M]M-[D]D,[h]h:mm:ss.0,[+ -][T]T:ZZ                                                                                                                                                                                     |
| <b>cable oudp-leak-detect session-id &lt;parent id&gt; start<br/>now stop never</b>                                           | In lieu of specifying the Date-and-Time format, the option start <b>now</b> and stop <b>never</b> are supported.<br><br>A test session that is stop <b>never</b> must be manually stopped or deleted by the administrator.                             |
| <b>cable oudp-leak-detect session-id &lt;parent id&gt;<br/>frequency start &lt;hertz&gt; end &lt;hertz&gt;</b>                | Sets the start and end frequencies of the OUDP parent test session. The OUDP child test session includes all minislots, which include the parent test session frequency range.<br><br>The valid range is 4500000-204500000 Hz.                         |



| EXEC CLI Command                                                                                                                                                                                                          | Description                                                                                                                                                                                                                                                                                                                                                                                                                                                                                                                                                                                                                                                                                                                          |
|---------------------------------------------------------------------------------------------------------------------------------------------------------------------------------------------------------------------------|--------------------------------------------------------------------------------------------------------------------------------------------------------------------------------------------------------------------------------------------------------------------------------------------------------------------------------------------------------------------------------------------------------------------------------------------------------------------------------------------------------------------------------------------------------------------------------------------------------------------------------------------------------------------------------------------------------------------------------------|
| <b>cable oudp-leak-detect session-id &lt;parent id&gt; transmit burst duration &lt;3..50&gt; gap &lt;0..50&gt; [[cycle-gap &lt;0..400&gt;] [fixed-bursts-per-cycle &lt;1..400&gt;]]   cycle-time &lt;milliseconds&gt;</b> | <p>Sets the OUDP parent test session OUDP transmit burst parameters for burst duration, burst gap and either cycle-gap or cycle-time.</p> <p>Cycle-Gap complies with the OSSI specifications for OUDP testing. The OUDP test cycle repeat interval is measured in frames.</p> <p>Cycle-Time provides a time-based repeat interval for the OUDP test cycle that is compatible with RF-detectors requiring a minimum repeat burst interval.</p> <ul style="list-style-type: none"> <li>• The valid range for burst-duration is 3-50 frames.</li> <li>• The valid range for burst-gap is 0-50 frames.</li> <li>• The valid range for cycle-gap is 0-400 frames.</li> <li>• The valid range for cycle-time is 100-20000 msec.</li> </ul> |
| <b>cable oudp-leak-detect session-id &lt;id&gt;controller upstream-cable &lt;slot/subslot/ctrlr&gt; [us-channel &lt;us-chan&gt;]</b>                                                                                      | <p>Sets the OUDP parent test session interface to specify an upstream-cable controller, or upstream-cable controller channel.</p> <p>A controller upstream-cable interface may expand to include up to two OFDMA channels/child test session.</p> <p>A controller upstream-cable channel specifies a single OFDMA channel/child session.</p>                                                                                                                                                                                                                                                                                                                                                                                         |
| <b>cable oudp-leak-detect session-id &lt;id&gt; interface Cable &lt;slot/subslot/md-idx&gt;</b>                                                                                                                           | <p>Sets the OUDP parent test session interface to specify a mac-domain.</p> <p>A Cable MAC domain interface may expand to include up to four OFDMA channels/child sessions.</p>                                                                                                                                                                                                                                                                                                                                                                                                                                                                                                                                                      |
| <b>cable oudp-leak-detect session-id &lt;parent-id&gt; cm-add &lt;mac-address&gt;</b>                                                                                                                                     | <p>Adds the MAC address to the parent test session CM-List.</p>                                                                                                                                                                                                                                                                                                                                                                                                                                                                                                                                                                                                                                                                      |
| <b>cable oudp-leak-detect session-id &lt;parent-id&gt; cm-delete &lt;mac-address&gt;</b>                                                                                                                                  | <p>Removes the MAC address from the parent test session CM-List.</p>                                                                                                                                                                                                                                                                                                                                                                                                                                                                                                                                                                                                                                                                 |
| <b>cable oudp-leak-detect session-id &lt;parent-id&gt;strict-cm-list</b>                                                                                                                                                  | <p>Requires the child test sessions to preserve the CM-List position of modems in the parent test session CM-List.</p>                                                                                                                                                                                                                                                                                                                                                                                                                                                                                                                                                                                                               |
| <b>cable oudp-leak-detect session-id &lt;parent-id&gt; reserved-probe-pct &lt;0-50&gt;</b>                                                                                                                                | <p>Reserves a percentage of frames in the OUDP test cycle for OFDMA channel upstream profile management probes.</p> <p>The default value is 3%.</p>                                                                                                                                                                                                                                                                                                                                                                                                                                                                                                                                                                                  |

| EXEC CLI Command                                                                                                             | Description                                                                                                                                                                                                                                                                                                                                                                                                                                                                                                                                                                                 |
|------------------------------------------------------------------------------------------------------------------------------|---------------------------------------------------------------------------------------------------------------------------------------------------------------------------------------------------------------------------------------------------------------------------------------------------------------------------------------------------------------------------------------------------------------------------------------------------------------------------------------------------------------------------------------------------------------------------------------------|
| <b>cable oudp-leak-detect session-id &lt;parent-id&gt; clear</b><br><b>[cm-list   cm-stats   interface   strict-cm-list]</b> | <p>Clears the specified item.</p> <p><b>cm-list</b>—Removes all modems from the CM-List of an OUDP parent test session in CONFIG or PENDING state.</p> <p><b>interface</b>—Removes the interface config from a OUDP parent test session in CONFIG or PENDING state.</p> <p><b>strict-cm-list</b>—Removes the <b>strict-cm-list</b> setting from a OUDP parent test session in CONFIG or PENDING state.</p> <p><b>cm-stats</b>—Clears the accumulated burst statistics of all OUDP child test session in ACTIVE state. Stats will immediately restart accumulating from starting from 0.</p> |
| <b>cable oudp-leak-detect session-id &lt;parent-id&gt; session preview</b>                                                   | <p>Allows the system admin to preview the child test session create from an OUDP parent test session prior to the pretest setup time.</p> <p>Child test sessions and modems are created based on the current state of the system, and are not guaranteed to be the same at the actual pretest setup time when child test sessions are rebuilt for the actual test start.</p>                                                                                                                                                                                                                |
| <b>cable oudp-leak-detect session-id &lt;parent-id&gt; session supha-recover</b>                                             | <p>Provides a mechanism for the child test sessions to be restored to the Active SUP. Existing child test sessions are deleted and all cable line cards update the SUP with their current child test sessions.</p> <p>Not recommended for normal system operational use.</p>                                                                                                                                                                                                                                                                                                                |
| <b>cable oudp-leak-detect delete all</b>                                                                                     | <p>Deletes all OUDP test sessions regardless of state.</p> <p><b>Note</b> Warning: Once deleted all CM burst stats are lost.</p>                                                                                                                                                                                                                                                                                                                                                                                                                                                            |
| <b>cable oudp-leak-detect clear system-boot-holdoff</b>                                                                      | <p>Allows the administrator to manually terminate the OUDP <b>system-boot-holdoff</b> timer. OUDP test sessions are started based on the state of the OFDMA channels and modems.</p>                                                                                                                                                                                                                                                                                                                                                                                                        |
| <b>cable oudp-leak-detect session-id &lt;parent-id&gt; probe-in-burst-gap &lt;enable disable&gt;</b>                         | <p>Allow/Disallow OFDMA channel probes in OUDP burst gap frames.</p> <p>This command is introduced in the Cisco IOS XE Bengaluru 17.6.1z1 release.</p>                                                                                                                                                                                                                                                                                                                                                                                                                                      |

## Global Configuration Mode Command Summary

| Global Config CLI Command                                                    | Description                                                                                                                                                                                                                                                                                                                  |
|------------------------------------------------------------------------------|------------------------------------------------------------------------------------------------------------------------------------------------------------------------------------------------------------------------------------------------------------------------------------------------------------------------------|
| <b>cable oudp-leak-detect pre-test-setup-time</b><br><seconds>               | The valid range is 10-300 seconds. The default value is 60 seconds.                                                                                                                                                                                                                                                          |
| <b>cable oudp-leak-detect expire-age</b> <days>                              | The valid range is 1-7 days. The default value is 3 days.                                                                                                                                                                                                                                                                    |
| <b>cable oudp-leak-detect system-boot-holdoff</b><br><minutes>               | The valid range is 10-120 minutes. The default value is 15 minutes.                                                                                                                                                                                                                                                          |
| <b>cable oudp-leak-detect reserved-probe-pct</b><br><percentage>             | The valid range is 0-50 percent. The default value is 3 percent.                                                                                                                                                                                                                                                             |
| <b>cable oudp-leak-detect ccap-modem-select</b><br><b>allow-late-cm-join</b> | Enables modems to join child test sessions after they reach the active state. Normal rules for CM-List and interface modem participation apply.                                                                                                                                                                              |
| <b>cable oudp-leak-detect adjust-test-time</b><br>[all icmts none]           | <p>OUUDP tests are scheduled based on the PTP/GPS clock time. The cable line card scheduler uses the DOCSIS frame clock. This command enables a timing adjustment between the GPS clock and the DOCSIS clock. Normally RPHY will not require the time adjustment, whereas iCMTS does.</p> <p>The default value is icmts.</p> |
| <b>cable oudp-leak-detect probe-in-burst-gap</b>                             | <p>Allow OFDMA channel probes in OUDP burst gap frames. This option is enabled by default.</p> <p>This command is introduced in the Cisco IOS XE Bengaluru 17.6.1z1 release.</p>                                                                                                                                             |

## Configuration Mode Command Summary

| Config CLI Command                                                                    | Description                                                                                                                                                                                                               |
|---------------------------------------------------------------------------------------|---------------------------------------------------------------------------------------------------------------------------------------------------------------------------------------------------------------------------|
| <b>cable oudp-leak-detect burst-profile</b> <#>                                       | <p>Creates a OUDP burst profile and enters the burst profile configuration sub-mode. See the <a href="#">OUUDP Burst-Profile Sub-Mode Config CLI Commands</a> for more information.</p> <p>The valid range is 1-9999.</p> |
| <b>cable oudp-leak-detect schedule burst-profile</b><br><#> start datetime <datetime> | Creates a persistent one-time scheduled test session.                                                                                                                                                                     |
| <b>cable oudp-leak-detect schedule burst-profile</b><br><#> start now stop never      | Creates a persistent 24x7 OUDP test session.                                                                                                                                                                              |

| Config CLI Command                                                                                                             | Description                                                                                                                                                                                                   |
|--------------------------------------------------------------------------------------------------------------------------------|---------------------------------------------------------------------------------------------------------------------------------------------------------------------------------------------------------------|
| <b>cable oudp-leak-detect schedule recurring weekday &lt;days&gt; start timeofday &lt;time&gt; stop timeofday &lt;time&gt;</b> | <p>Creates a persistent weekly test session that runs at the same time, each day, on configured weekdays (“SuMoTuWeThFrSa”).</p> <p>One or more weekdays, for example, “<b>MoWeFr</b>” must be specified.</p> |

## OUUDP Burst-Profile Sub-Mode Config CLI Commands

| OUUDP Burst-Profile Sub-Mode Config CLI Commands                                                                                   | Description                                                                                                                                                                                                                                                                                                                                                                                                                                                                                                                                                                                                                                                                                                                                     |
|------------------------------------------------------------------------------------------------------------------------------------|-------------------------------------------------------------------------------------------------------------------------------------------------------------------------------------------------------------------------------------------------------------------------------------------------------------------------------------------------------------------------------------------------------------------------------------------------------------------------------------------------------------------------------------------------------------------------------------------------------------------------------------------------------------------------------------------------------------------------------------------------|
| <b>transmit burst duration &lt;burst-dur&gt; gap &lt;burst-gap&gt; [cycle-gap &lt;cycle-gap&gt; cycle-time &lt;cycle-time&gt;]</b> | <p>Sets the OUUDP parent test session and OUUDP transmit burst parameters for burst duration, burst gap, and either cycle-gap or cycle-time.</p> <p>Cycle-Gap complies with the OSSI specifications for OUUDP testing. The OUUDP test cycle repeat interval is measured in frames.</p> <p>Cycle-Time provides a time-based repeat interval for the OUUDP test cycle that is compatible with RF-detectors requiring a minimum repeat burst interval.</p> <ul style="list-style-type: none"> <li>• The valid range for burst-duration is 3-50 frames.</li> <li>• The valid range for burst-gap is 0-50 frames.</li> <li>• The valid range for cycle-gap is 0-400 frames.</li> <li>• The valid range for cycle-time is 100-20000 msecs.</li> </ul> |
| <b>frequency start &lt;start-hz&gt; end &lt;end-hz&gt;</b>                                                                         | <p>Sets the start and end frequencies of the OUUDP parent test session. The OUUDP child test session includes all minislots, which include the parent test session frequency range.</p> <p>The valid range is 4500000-204500000 Hz.</p>                                                                                                                                                                                                                                                                                                                                                                                                                                                                                                         |
| <b>controller upstream-cable &lt;slot/subslot/ctrlr&gt; [us-channel &lt;ofdma-us-channel&gt;</b>                                   | <p>Sets the OUUDP parent test session interface to specify an upstream-cable controller, or upstream-cable controller channel.</p> <p>A controller upstream-cable interface may expand to include up to two OFDMA channels/child test session.</p> <p>A controller upstream-cable channel specifies a single OFDMA channel/child session.</p>                                                                                                                                                                                                                                                                                                                                                                                                   |
| <b>interface cable &lt;slot/subslot/md-idx&gt;</b>                                                                                 | <p>Sets the OUUDP parent test session interface to specify a mac-domain.</p> <p>A Cable MAC domain interface may expand to include up to four OFDMA channels/child sessions.</p>                                                                                                                                                                                                                                                                                                                                                                                                                                                                                                                                                                |
| <b>cm-list &lt;IOS-filesystem:filename&gt;</b>                                                                                     | <p>Configure the OUUDP parent test session to load the CM-List from an IOS filesystem file. The harddisk, bootflash, and usb0 file systems are supported. See the <a href="#">CM-List Format</a> for the text file format.</p>                                                                                                                                                                                                                                                                                                                                                                                                                                                                                                                  |

| OU DP Burst-Profile Sub-Mode Config CLI Commands | Description                                                                                                                                                                                                                                                                                              |
|--------------------------------------------------|----------------------------------------------------------------------------------------------------------------------------------------------------------------------------------------------------------------------------------------------------------------------------------------------------------|
| <b>strict-cm-list</b>                            | Requires the child test sessions to preserve the CM-List position of modems in the parent test session CM-List.                                                                                                                                                                                          |
| <b>reserved-probe-pct &lt;0-50&gt;</b>           | Reserves a percentage of frames in the OUDP test cycle for OFDMA channel upstream profile management probes. When configured under the OUDP burst-profile, this value overrides the global configuration parameter of the same name.<br><br>If not configured, burst-profiles use global default values. |
| <b>probe-in-burst-gap</b>                        | Allow OFDMA channel probes in OUDP burst gap frames. If not configured, burst-profiles use global default values.<br><br>This command is introduced in the Cisco IOS XE Bengaluru 17.6.1z1 release.                                                                                                      |

## Show OUDP Command Summary

| Show Command                                                        | Description                                                                                                                                                                                                                                                                                                                  |
|---------------------------------------------------------------------|------------------------------------------------------------------------------------------------------------------------------------------------------------------------------------------------------------------------------------------------------------------------------------------------------------------------------|
| <b>show cable oudp-leak-detect settings</b>                         | Displays the values of OUDP global configuration parameters and the CBR-8 capabilities (specifically the OSSI <b>SupportsNumBurstsNotReceived</b> —We support <b>RxNoEnergy</b> stat.)                                                                                                                                       |
| <b>show cable oudp-leak-detect test-sessions</b>                    | Displays summary of the test session that includes parent/child IDs, start/stop times, interfaces, and status.                                                                                                                                                                                                               |
| <b>show cable oudp-leak-detect session-id &lt;id&gt; detail</b>     | Displays the parent or child test session details.<br><br>Includes OSSI information pertaining to: <ul style="list-style-type: none"> <li>• LeakageDetectionTestSessionStatus</li> <li>• LeakageDetectionTestChannelStatus</li> </ul>                                                                                        |
| <b>show cable oudp-leak-detect session [id &lt;id&gt;] cm-stats</b> | Displays the child test session CM stats for BurstGrants, BurstRx, BurstNoEnergyRx, and BytesRx.<br><br>Includes OSSI information pertaining to: <ul style="list-style-type: none"> <li>• LeakageDetectionTestSessionStats</li> </ul> <p>All child session CM stats are displayed when the parent session-id is entered.</p> |
| <b>show cable oudp-leak-detect system-boot-holdoff</b>              | Time delay during system boot to allow OFDMA channels to reach UP state and CMs to reach online. After this holdoff time expires, OUDP test sessions will begin.                                                                                                                                                             |

| Show Command                                                     | Description                                                                                                                                                     |
|------------------------------------------------------------------|-----------------------------------------------------------------------------------------------------------------------------------------------------------------|
| <b>show cable oudp-leak-detect burst-profiles</b>                | Displays persistent OUDP burst profiles configured in NVRAM (startup-config).                                                                                   |
| <b>show cable oudp-leak-detect schedules</b>                     | Displays persistent OUDP schedules configured in NVRAM (startup-config).                                                                                        |
| <b>show cable oudp-leak-detect rf-detector</b>                   | Displays currently available OFDMA channels and frequencies in the system. Useful for identifying OFDMA channel participation for a given OUDP frequency range. |
| <b>show cable oudp-leak-detect docsis-clock slot &lt;0-9&gt;</b> | Displays the timing reference information of the SUP and selected cable line card slot.                                                                         |

## Related Show Command Summary

| Related Show CLI Commands                                                                                     | Description                                                                              |
|---------------------------------------------------------------------------------------------------------------|------------------------------------------------------------------------------------------|
| <b>show cable modem &lt;mac-address&gt; verbose   incl OUDP</b>                                               | Displays CM verbose information containing new lines for OUDP test participation.        |
| <b>scm &lt;mac-address&gt; qos</b>                                                                            | Displays information about the OUDP Burst Test (OBT) SID.                                |
| <b>show controller upstream-Cable &lt;slot&gt;/0/&lt;ctrlr&gt; us-channel &lt;12-15&gt;   incl OUDP</b>       | Displays the Last Enroll Error for an OFDMA channel (if available).                      |
| <b>show controller upstream-Cable &lt;slot&gt;/0/&lt;ctrlr&gt; us-channel &lt;12-15&gt; cdm-ump   i OBT</b>   | Displays the UMP start and end minislot values.                                          |
| <b>show interface cable &lt;slot&gt;/0/&lt;md_idx&gt; sid oudp-counters</b>                                   | Displays the OUDP stats for the specified SID.                                           |
| <b>show interface cable &lt;slot&gt;/0/&lt;md_idx&gt; mac-scheduler &lt;us-channel&gt; map-stats</b>          | Displays the OBT scheduler SID table. Indicates burst/gap positions and SID assignments. |
| <b>show interface cable &lt;slot&gt;/0/&lt;md_idx&gt; mac-scheduler &lt;us-channel&gt;</b>                    | Displays the OFDMA IUC reservation percentage due to OUDP testing.                       |
| <b>show cable admission-control interface cable &lt;slot&gt;/0/&lt;md_idx&gt; upstream &lt;us-channel&gt;</b> | Displays the admission control rate reservation required by the OUDP test.               |

## Example: Configuration Command Mode

This example shows how to create a burst profile in the configuration mode:

```
Router#config terminal
Enter configuration commands, one per line. End with CNTL/Z.
```

```
Router(config)#cable oudp-leak-detect burst-profile 55
Router(config-oudp-burst-profile)#frequency start 45000000 end 50000000
Router(config-oudp-burst-profile)#$burst duration 4 gap 2 cycle-gap 10
OUDP cycle-gap can support 53 bursts in the test cycle
Router(config-oudp-burst-profile)#cm-list harddisk:oudp-cm-list-1
Router(config-oudp-burst-profile)#$leak-detect schedule burst-profile 55 recurring
weekdays MoTuWeThFr start timeofday 15:45:00 stop timeofday 18:00:00
```

## Example: EXEC Command Mode

The example shows the creation of a session and assigning the required test parameters.

1. Configure an OUDP session.

```
Router#cable oudp-leak-detect session-id 99 session create
```

2. Configure the frequency test parameters for the OUDP session.

```
Router#cable oudp sess 99 frequency start 60000000 end 66000000
```

3. Configure the Burst Duration and Cycle Gap test parameters.

```
Router#cable oudp sess 99 transmit burst duration 6 gap 4 cycle-gap 20
OUDP cycle-gap can support 64 bursts in the test cycle
```

4. Configure the list of cable modems intended to participate in sending test bursts.

```
Router#cable oudp sess 99 cm-add 4800.33ea.70c2
Router#cable oudp sess 99 cm-add 4800.33ea.71ba
Router#cable oudp sess 99 cm-add 4800.33ee.ff9a
Router#cable oudp sess 99 cm-add 4800.33ef.0c56
Router#cable oudp sess 99 cm-add 4800.33ef.0c5e
```

5. Configure the start time and end time for the test bursts.

```
Router#cable oudp-leak-detect session-id 99 start datetime 2022-01-01,12:00:00.0,
-5:00 stop datetime 2022-01-02,12:00:00.0,-5:00
```

## Verifying the OUDP Session

The **show cable oudp-leak-detect test-sessions** command shows all OUDP test sessions present on the cBR-8. The status of each session will indicate whether it is CONFIG when the configuration is in process or after a session reset, PENDING with a future start time, in PRETEST\_SETUP just prior to the test start, ACTIVE with OUDP burst grants, CLEANUP for final stats collection, or COMPLETE.

```
Router#show cable oudp-leak-detect test-sessions
Load for five secs: 5%/0%; one minute: 6%; five minutes: 6%
Time source is NTP, 14:14:05.873 EST Wed Jul 27 2022
```

```
OUDP Test Sessions: 2
```

| Parent | Child | Interface   | Modems | Status | Start-Time                  | Stop-Time |
|--------|-------|-------------|--------|--------|-----------------------------|-----------|
| 99     | -     | -           | 0      | ACTIVE | 2022-07-27,12:45:03.0,-5:00 | never     |
| 99     | 10002 | Ca1/0/2/U14 | 2      | ACTIVE | 2022-07-27,12:45:03.0,-5:00 | never     |

The **show cable oudp-leak-detect session-id <id> detail** command can be used for either parent or child test sessions. Parent session details show the test parameters as they are configured.

```
Router#show cable oudp-leak-detect session-id 99 detail
Load for five secs: 7%/0%; one minute: 6%; five minutes: 6%
```

```
Time source is NTP, 12:44:33.214 EST Wed Jul 27 2022
```

```
OU DP Test Session : 99 (parent)
```

```
Status : PRETEST
Start Time : 2022-07-27,12:45:03.0,-5:00
Stop Time : never
Burst Duration : 6 (frames)
Burst Gap : 4 (frames)
Cycle Gap : 20 (frames)
Reserved Probe Pct : 3
Freq Start : 60000000 (Hz)
Freq End : 66000000 (Hz)
Interface : controller upstream-cable 1/0/3 us-channel 12
CM-List : 0 modems
```

Child session detail shows test information as it pertains to the particular OFDMA channel.

```
Router#show cable oudp-leak-detect session-id 10002 detail
Load for five secs: 5%/0%; one minute: 6%; five minutes: 6%
Time source is NTP, 14:12:35.623 EST Wed Jul 27 2022
```

```
OU DP Test Session : 10002 (child)
```

```
Interface : Cable1/0/2 upstream 14
Status : ACTIVE
Start Time : 2022-07-27,12:45:03.0,-5:00
Stop Time : never
Burst Duration : 6 (frames)
Burst Gap : 4 (frames)
Cycle Gap : 20 (frames)
Reserved Probe Pct : 3
```

```
Actual SC Freq Start : 59700000 (Hz)
Actual SC Freq End : 66075000 (Hz)
Minislot Start : 38
Minislot End : 53
Microsec per frame : 573.000 (usec)
Burst Spacing : 5730.000 (usec)
```

```
Test Session Type : CycleGap
Current Bursts per cycle : 2
Maximum Bursts per cycle : 64
Probe Oppty per cycle : 20 (frames)
Cycle Interval Info : 2 (bursts) / 40.00 (frames) / 22.920 (msec)
```

```
Child Session 10002, Cable1/0/2 upstream 14 - CM-List 2 modems
CM Mac-Address BurstPos Offset(us) Test Sid BurstGrants BurstNoEnergyRx BurstRx TestBytesRx
4800.33ea.71ba 0 0 27 1373428 0 1371040 2107288480
4800.33ea.70c2 1 5730 28 1373418 0 1371030 2107273110
```

## Example: Creating a Test Session on Selected Modems Using the EXEC Mode

This example is to create a test session where the operator has requested that the cBR-8 choose the modems.

MAC-Address Wildcard—All CLCs and All OFDMA channels

```
cable oudp-leak-detect session-id 5 session create
cable oudp-leak-detect session-id 5 frequency start 138100000 end 139650000
```



```
cable oudp-leak-detect session-id 5 transmit burst duration 4 gap 2 cycle-gap 10
cable oudp-leak-detect session-id 5 cm-add FFFF.FFFF.FFFF
cable oudp-leak-detect session-id 5 start datetime 2022-01-01,12:00:00.0,-5:00
stop datetime 2022-01-02,12:00:00.0,-5:00
```

MAC-Domain Example—All configured OFDMA channels on the MAC-Domain

```
cable oudp-leak-detect session-id 5 interface Cable9/0/0
```

Controller Example—Single controller and one or two OFDMA channels

```
cable oudp-leak-detect session-id 5 controller upstream-cable 9/0/0
cable oudp-leak-detect session-id 5 controller upstream-cable 9/0/0 us-channel 13
```

## Specifications

The support for RF leakage detection is defined in the following specifications:

- CableLabs OSSI Specification: CM-SP-CCAP-OSSIV3.1-I24-220518



---

**Note** The implementation tracks closely to, but does not 100% match the OSSI specification. OSSI specification development was in progress during the time of this implementation.

---

- Upstream OFDMA Data Profile Testing Burst method as defined in the CableLabs MULPI Specification CM-SP-MULPIv3.1-I23-220328

## Recommendations for the OFDMA Burst Testing Channel Configuration

- OFDMA channel IUC 13 is used by the the cBR-8 to schedule test bursts. Change the IUC 13 parameters as necessary to match compatibility with the leakage detection equipment in use.
- Operations Support System Interface (OSSI) recommends the use of pilot pattern 4 or 11 for OFDMA Burst Testing. OSSI recommends not to use boosted pilot patterns.
- cBR-8 supports all OFDMA pilot pattern configurations for OFDMA Burst Testing, if desired by the operator.

## Example: Channel Configuration for a Third-Party Leak Detector

This example shows the channel configuration for detecting leaks using a digital leak detector.

The following steps are to configure OFDMA controller profile:

```
Router# enable
Router# configure terminal
Router(config)#cable mod-profile-ofdma 420
Router(config)#subcarrier-spacing 25KHz
```

```

Router(config)#initial-rng-subcarrier 64
Router(config)#initial-rng-preamble 8
Router(config)#fine-rng-subcarrier 512
Router(config)#data-iuc 9 modulation 2048-QAM pilot-pattern 9
Router(config)#data-iuc 10 modulation 1024-QAM pilot-pattern 9
Router(config)#data-iuc 11 modulation 512-QAM pilot-pattern 8
Router(config)#data-iuc 12 modulation 256-QAM pilot-pattern 8
##### CableLabs OSSI recommends 11 for 25 kHz SC spacing#####
#####CableLabs OSSI recommends 4 for 50 kHz SC spacing#####
##### CableLabs OSSI recommends not to use boosted pilot patterns#####
Router(config)#data-iuc 13 modulation 64-QAM pilot-pattern 11#####

```

To configure upstream controller profile, use the steps below:

```

Router# enable
Router# configure terminal
Router(config)#cable upstream controller-profile id [RPHY|I-CMTS]
Router(config)#us-channel 13 docsis-mode ofdma
Router(config)#us-channel 13 subcarrier-spacing 25KHz
Router(config)#us-channel 13 modulation-profile 420
Router(config)#us-channel 13 frequency-range 108000000 204000000
Router(config)#us-channel 13 initial-rng-frequency-start 184000000
Router(config)# us-channel 13 cyclic-prefix 256 roll-off-period 128
Router(config)#us-channel 13 symbols-per-frame 9
Router(config)#no us-channel 13 shutdown

```

## OUDP DOCS-LEAK-DETECT MIB

Table 140: Feature History

| Feature Name                                               | Release Information          | Feature Description                                                                                                                                                                                                                                                                                                                                                                                                                        |
|------------------------------------------------------------|------------------------------|--------------------------------------------------------------------------------------------------------------------------------------------------------------------------------------------------------------------------------------------------------------------------------------------------------------------------------------------------------------------------------------------------------------------------------------------|
| New MIBs for OUDP doc leakage detection (DOCS-LEAK-DETECT) | Cisco IOS XE Dublin 17.12.1w | <p>New MIB support helps to fetch the details of OUDP leak detect test sessions.</p> <p>The following are the new MIBs supported:</p> <ul style="list-style-type: none"> <li>docsLeakDetTestCapabilities</li> <li>docsLeakDetTestSessionStatusTable</li> <li>docsLeakDetTestSessionStatsTable</li> <li>docsLeakDetTestChannelStatusTable</li> </ul> <p>Supported MIB version:<br/> <a href="#">DOCS-LEAK-DETECT-MIB-2022-09-15.txt</a></p> |

The OUDP leakage detection feature supports the following new DOCSIS leak detection MIBs.

- docsLeakDetTestCapabilities
- docsLeakDetTestSessionStatusTable
- docsLeakDetTestSessionStatsTable
- docsLeakDetTestChannelStatusTable

Supported MIB version: [DOCS-LEAK-DETECT-MIB-2022-09-15.txt](#).

The following table indicates the object names and the corresponding OIDs for the DOCS-LEAK-DETECT MIB:

**Table 141: DOCS-LEAK-DETECT**

| Object Name                                     | Corresponding MIB OID value        |
|-------------------------------------------------|------------------------------------|
| docsLeakDetectMib                               | 1.3.6.1.4.1.4491.2.1.37            |
| docsLeakDetObjects                              | 1.3.6.1.4.1.4491.2.1.37.1          |
| docsLeakDetTestObjects                          | 1.3.6.1.4.1.4491.2.1.37.1.1        |
| docsLeakDetTestCapabilities                     | 1.3.6.1.4.1.4491.2.1.37.1.1.1      |
| docsLeakDetTestSupportsNumBurstsNotReceived     | 1.3.6.1.4.1.4491.2.1.37.1.1.1.1    |
| docsLeakDetTestSessionStatusTable               | 1.3.6.1.4.1.4491.2.1.37.1.1.2      |
| docsLeakDetTestSessionStatusEntry               | 1.3.6.1.4.1.4491.2.1.37.1.1.2.1    |
| docsLeakDetTestSessionStatusSessionType         | 1.3.6.1.4.1.4491.2.1.37.1.1.2.1.2  |
| docsLeakDetTestSessionStatusStatus              | 1.3.6.1.4.1.4491.2.1.37.1.1.2.1.3  |
| docsLeakDetTestSessionStatusStartTime           | 1.3.6.1.4.1.4491.2.1.37.1.1.2.1.4  |
| docsLeakDetTestSessionStatusStopTime            | 1.3.6.1.4.1.4491.2.1.37.1.1.2.1.5  |
| docsLeakDetTestSessionStatsTable                | 1.3.6.1.4.1.4491.2.1.37.1.1.3      |
| docsLeakDetTestSessionStatsEntry                | 1.3.6.1.4.1.4491.2.1.37.1.1.3.1    |
| docsLeakDetTestSessionStatsNumBurstsGranted     | 1.3.6.1.4.1.4491.2.1.37.1.1.3.1.2  |
| docsLeakDetTestSessionStatsNumBurstsNotReceived | 1.3.6.1.4.1.4491.2.1.37.1.1.3.1.3  |
| docsLeakDetTestSessionStatsNumTestBytesReceived | 1.3.6.1.4.1.4491.2.1.37.1.1.3.1.4  |
| docsLeakDetTestChannelStatusTable               | 1.3.6.1.4.1.4491.2.1.37.1.1.4      |
| docsLeakDetTestChannelStatusEntry               | 1.3.6.1.4.1.4491.2.1.37.1.1.4.1    |
| docsLeakDetTestChannelStatusTestStartFreq       | 1.3.6.1.4.1.4491.2.1.37.1.1.4.1.2  |
| docsLeakDetTestChannelStatusTestEndFreq         | 1.3.6.1.4.1.4491.2.1.37.1.1.4.1.3  |
| docsLeakDetTestChannelStatusNumModemsCfg        | 1.3.6.1.4.1.4491.2.1.37.1.1.4.1.4  |
| docsLeakDetTestChannelStatusNumModemsActive     | 1.3.6.1.4.1.4491.2.1.37.1.1.4.1.5  |
| docsLeakDetTestChannelStatusFirstSubcarrierId   | 1.3.6.1.4.1.4491.2.1.37.1.1.4.1.6  |
| docsLeakDetTestChannelStatusLastSubcarrierId    | 1.3.6.1.4.1.4491.2.1.37.1.1.4.1.7  |
| docsLeakDetTestChannelStatusBurstIuc            | 1.3.6.1.4.1.4491.2.1.37.1.1.4.1.8  |
| docsLeakDetTestChannelStatusCurrCycleTime       | 1.3.6.1.4.1.4491.2.1.37.1.1.4.1.9  |
| docsLeakDetTestChannelStatusNumBurstPositions   | 1.3.6.1.4.1.4491.2.1.37.1.1.4.1.10 |



**Note** The *docsLeakDetTestSessionStatusSessionId*, *docsLeakDetTestSessionStatsCmMacAddress*, and *docsLeakDetTestChannelStatusInterfaceName* are indices and cannot be accessed.

**Doc Leak Detection MIBs**

- [docsLeakDetTestCapabilities](#)—Reports number of leakage detection bursts.
- [docsLeakDetTestSessionStatusTable](#)—Reports session status for the parent and child sessions.
- [docsLeakDetTestSessionStatsTable](#)—Reports session stats for the individual or child sessions.
- [docsLeakDetTestChannelStatusTable](#)—Reports channel status for the individual or child sessions.

**docsLeakDetTestCapabilities**

The *docsLeakDetTestSupportsNumBurstsNotReceived* MIB object provides a report on the number of leakage detection testing bursts that are not received. This attribute reports the CCAP line card capability and has the following values:

- *True*—Indicates that the test session reports a valid value for the count of leakage detection testing bursts it did not receive during a leakage detection.

The system supports the reporting of a count for leakage detection testing bursts not received through the counter *burst\_no\_energy\_rx* which is reported through CLI. Hence this object takes the value *true* indicating support.

The following output shows the details of the **docsLeakDetTestSupportsNumBurstsNotReceived** MIB object:

```
docsLeakDetTestSupportsNumBurstsNotReceived OBJECT-TYPE
SYNTAX TruthValue
MAX-ACCESS read-only
STATUS current
::= { docsLeakDetTestCapabilities 1 }
```

The following output is a sample output of the **docsLeakDetTestSupportsNumBurstsNotReceived**:

```
router> getmany -v2c 8.17.1.1 private docsLeakDetTestSupportsNumBurstsNotReceived
docsLeakDetTestSupportsNumBurstsNotReceived.0 = true(1)
router> getmany -v2c 8.17.1.1 private 1.3.6.1.4.1.4491.2.1.37.1.1.1
docsLeakDetTestSupportsNumBurstsNotReceived.0 = true(1)
```

**docsLeakDetTestSessionStatusTable**

The *docsLeakDetTestSessionStatusTable* MIBs reports the status, start, and stop time of the leakage detection test session.

The Leakage Detection Test Session Status table reports the status of a specified leakage detection test session. Rows in this table are created and maintained by the CCAP. Leakage Detection Test Session status is reported for all the session types.

The following output shows the details of the **docsLeakDetTestSessionStatusTable** MIB object:

```
docsLeakDetTestSessionStatusEntry ::= SEQUENCE {
    docsLeakDetTestSessionStatusSessionId      Unsigned32,
    docsLeakDetTestSessionStatusSessionType    INTEGER,
    docsLeakDetTestSessionStatusStatus         INTEGER,
    docsLeakDetTestSessionStatusStartTime      DateAndTime,
```

```

        docsLeakDetTestSessionStatusStopTime      DateAndTime
    }

```

### Verifying the Leakage Detection Test Session Status Configuration

The following is the show output for `docsLeakDetTestSessionStatusTable`:

```

router#show cable oudp session-id 90020 detail
Load for five secs: 6%/0%; one minute: 8%; five minutes: 8%
Time source is NTP, 08:34:11.241 EDT Tue Aug 1 2023
OUDP Test Session : 90020 (child)
Interface          : Cable9/0/24 upstream 6
Status           : ACTIVE
Start Time       : 2023-08-01,08:33:15.0,-4:00
Stop Time        : 2023-08-01,09:00:00.0,-4:00
Burst Duration     : 6 (frames)
Burst Gap          : 4 (frames)
Cycle Time         : 100 (msec)
Reserved Probe Pct : 3
Probe in Burst Gap : Allowed
Actual SC Freq Start : 64900000 (Hz)
Actual SC Freq End   : 66075000 (Hz)
Minislot Start      : 61
Minislot End        : 63
Microsec per frame  : 510.000 (usec)
Burst Spacing       : 5100.000 (usec)

```

The following is the CLI output of the `docsLeakDetTestSessionStatusTable`.

```

router > getmany -v2c 8.17.1.1 private 1.3.6.1.4.1.4491.2.1.37.1.1.2
docsLeakDetTestSessionStatusSessionType.10 = master(2)
docsLeakDetTestSessionStatusSessionType.30 = master(2)
docsLeakDetTestSessionStatusSessionType.40 = master(2)
docsLeakDetTestSessionStatusSessionType.90020 = component(1)
docsLeakDetTestSessionStatusSessionType.90021 = component(1)
docsLeakDetTestSessionStatusStatus.10 = active(1)
docsLeakDetTestSessionStatusStatus.30 = pending(0)
docsLeakDetTestSessionStatusStatus.40 = active(1)
docsLeakDetTestSessionStatusStatus.90020 = active(1)
docsLeakDetTestSessionStatusStatus.90021 = active(1)
docsLeakDetTestSessionStatusStartTime.10 = 2023-Aug-1,08:33:15.0,-4:0
docsLeakDetTestSessionStatusStartTime.30 = 2023-Aug-1,08:45:00.0,-4:0
docsLeakDetTestSessionStatusStartTime.40 = 2023-Aug-1,08:33:21.0,-4:0
docsLeakDetTestSessionStatusStartTime.90020 = 2023-Aug-1,08:33:15.0,-4:0
docsLeakDetTestSessionStatusStartTime.90021 = 2023-Aug-1,08:33:21.0,-4:0
docsLeakDetTestSessionStatusStopTime.10 = 2023-Aug-1,09:00:00.0,-4:0
docsLeakDetTestSessionStatusStopTime.30 = 2023-Aug-1,10:00:00.0,-4:0
docsLeakDetTestSessionStatusStopTime.40 =
docsLeakDetTestSessionStatusStopTime.90020 = 2023-Aug-1,09:00:00.0,-4:0
docsLeakDetTestSessionStatusStopTime.90021 =

```

### docsLeakDetTestSessionStatsTable

The `docsLeakDetTestSessionStatsTable` MIB reports the number of bursts that are granted, received, and not received. Rows in this table are created and maintained by the CCAP.

```

docsLeakDetTestSessionStatsEntry ::= SEQUENCE {
    docsLeakDetTestSessionStatsCmMacAddress      MacAddress,
    docsLeakDetTestSessionStatsNumBurstsGranted Counter32,
    docsLeakDetTestSessionStatsNumBurstsNotReceived Counter32,
    docsLeakDetTestSessionStatsNumTestBytesReceived Counter64
}

```

### Verifying the Leakage Detection Test Session Stats Configuration

To verify the configuration parameters for leakage detection test session stats, use the **show cable oudp session-id 90003 cm-stats** command as shown in the following example:

```
router#show cable oudp session-id 90003 cm-stats
Load for five secs: 5%/0%; one minute: 7%; five minutes: 8%
Time source is NTP, 02:41:50.594 EDT Fri Aug 4 2023
Child Session 90003, Cable9/0/24 upstream 6 - CM-List 3 modems
CM Mac-Address BurstPos  Offset(us)  Test Sid  BurstGrants  BurstNoEnergyRx  BurstRx
TestBytesRx
4800.33ef.094e  0          0          13         15114         0              15000
6135000
4800.33ef.092a  1          5100       14         15114         0              15000
6135000
4800.33ef.07e2  2          10200      15         15114         0              15000
6135000
```

The following is the output of the **docsLeakDetTestSessionStatsTable** MIB that reports the number of bursts that are granted, received, and not received.

```
router > getmany -v2c 8.17.1.1 private 1.3.6.1.4.1.4491.2.1.37.1.1.3
docsLeakDetTestSessionStatsNumBurstsGranted.90003.72.0.51.239.9.78 = 15414
docsLeakDetTestSessionStatsNumBurstsGranted.90003.72.0.51.239.9.42 = 15414
docsLeakDetTestSessionStatsNumBurstsGranted.90003.72.0.51.239.7.226 = 15414
docsLeakDetTestSessionStatsNumBurstsNotReceived.90003.72.0.51.239.9.78 = 0
docsLeakDetTestSessionStatsNumBurstsNotReceived.90003.72.0.51.239.9.42 = 0
docsLeakDetTestSessionStatsNumBurstsNotReceived.90003.72.0.51.239.7.226 = 0
docsLeakDetTestSessionStatsNumTestBytesReceived.90003.72.0.51.239.9.78 = 6257700
docsLeakDetTestSessionStatsNumTestBytesReceived.90003.72.0.51.239.9.42 = 6257700
docsLeakDetTestSessionStatsNumTestBytesReceived.90003.72.0.51.239.7.226 = 6257700
router >
```



**Note** The CLI and MIB table values differ for active counters during execution and collection processes.

### docsLeakDetTestChannelStatusTable

The *docsLeakDetTestChannelStatusTable* MIB reports the configuration of a specified upstream OFDMA channel that is used for leakage detection testing. Rows in this table are created and maintained by the CCAP.

```
docsLeakDetTestChannelStatusEntry ::= SEQUENCE {
    docsLeakDetTestChannelStatusInterfaceName      SnmpAdminString,
    docsLeakDetTestChannelStatusTestStartFreq     Unsigned32,
    docsLeakDetTestChannelStatusTestEndFreq       Unsigned32,
    docsLeakDetTestChannelStatusNumModemsCfg      Unsigned32,
    docsLeakDetTestChannelStatusNumModemsActive   Unsigned32,
    docsLeakDetTestChannelStatusFirstSubcarrierId Unsigned32,
    docsLeakDetTestChannelStatusLastSubcarrierId  Unsigned32,
    docsLeakDetTestChannelStatusBurstIuc         Unsigned32,
    docsLeakDetTestChannelStatusCurrCycleTime    Unsigned32,
    docsLeakDetTestChannelStatusNumBurstPositions Unsigned32
}
```

### Verifying the Leakage Detection Channel Session Status Configuration

To verify the configuration parameters for leakage detection channel status, use the **show cable oudp-leak-detect session-id <> detail** command as shown in the following example:

```
router#show cable oudp-leak-detect session-id <> detail
Load for five secs: 6%/0%; one minute: 8%; five minutes: 8%
Time source is NTP, 08:34:11.241 EDT Tue Aug 1 2023
OUDP Test Session : 90020 (child)
```

```

Interface           : Cable9/0/24 upstream 6
Status              : ACTIVE
Start Time          : 2023-08-01,08:33:15.0,-4:00
Stop Time           : 2023-08-01,09:00:00.0,-4:00
Burst Duration      : 6 (frames)
Burst Gap           : 4 (frames)
Cycle Time          : 100 (msec)
Reserved Probe Pct : 3
Probe in Burst Gap  : Allowed
Actual SC Freq Start : 64900000 (Hz)
Actual SC Freq End   : 66075000 (Hz)
Minislot Start      : 61
Minislot End        : 63
Microsec per frame  : 510.000 (usec)
Burst Spacing       : 5100.000 (usec)
Test Session Type   : CycleTime
Current Bursts per cycle : 2
Maximum Bursts per cycle : 19
Probe Oppty per cycle : 6 (frames)
Cycle Interval Info : 19 (bursts) / 196.07 (frames) / 100.000 (msec)

```

```

Child Session 90020, Cable9/0/24 upstream 6 - CM-List 2 modems
CM Mac-Address BurstPos Offset(us) Test Sid BurstGrants BurstNoEnergyRx      BurstRx
TestBytesRx
4800.33ef.07e2      0          0          27          612          0          372
106020
4800.33ef.094e      1          5100        28          612          0          372
106020
router#

```

The following is the CLI output of the `docsLeakDetTestChannelStatusTable`:

```

mcp-cab-002:/auto/tftpboot-pit/mibs/snmp/bin/linux/17.1 > getmany -v2c 8.17.1.1 private
1.3.6.1.4.1.4491.2.1.37.1.1.4
docsLeakDetTestChannelStatusTestStartFreq.90020.18.67.97.57.47.48.47.50.52.45.117.112.115.116.114.101.97.109.54
= 64900000
docsLeakDetTestChannelStatusTestStartFreq.90021.18.67.97.57.47.48.47.51.48.45.117.112.115.116.114.101.97.109.54
= 61700000
docsLeakDetTestChannelStatusTestEndFreq.90020.18.67.97.57.47.48.47.50.52.45.117.112.115.116.114.101.97.109.54
= 66075000
docsLeakDetTestChannelStatusTestEndFreq.90021.18.67.97.57.47.48.47.51.48.45.117.112.115.116.114.101.97.109.54
= 63275000
docsLeakDetTestChannelStatusNumModemsCfg.90020.18.67.97.57.47.48.47.50.52.45.117.112.115.116.114.101.97.109.54
= 2
docsLeakDetTestChannelStatusNumModemsCfg.90021.18.67.97.57.47.48.47.51.48.45.117.112.115.116.114.101.97.109.54
= 3
docsLeakDetTestChannelStatusNumModemsActive.90020.18.67.97.57.47.48.47.50.52.45.117.112.115.116.114.101.97.109.54
= 2
docsLeakDetTestChannelStatusNumModemsActive.90021.18.67.97.57.47.48.47.51.48.45.117.112.115.116.114.101.97.109.54
= 3
docsLeakDetTestChannelStatusFirstSubcarrierId.90020.18.67.97.57.47.48.47.50.52.45.117.112.115.116.114.101.97.109.54
= 61
docsLeakDetTestChannelStatusFirstSubcarrierId.90021.18.67.97.57.47.48.47.51.48.45.117.112.115.116.114.101.97.109.54
= 53
docsLeakDetTestChannelStatusLastSubcarrierId.90020.18.67.97.57.47.48.47.50.52.45.117.112.115.116.114.101.97.109.54
= 63
docsLeakDetTestChannelStatusLastSubcarrierId.90021.18.67.97.57.47.48.47.51.48.45.117.112.115.116.114.101.97.109.54
= 56
docsLeakDetTestChannelStatusBurstIuc.90020.18.67.97.57.47.48.47.50.52.45.117.112.115.116.114.101.97.109.54
= 13
docsLeakDetTestChannelStatusBurstIuc.90021.18.67.97.57.47.48.47.51.48.45.117.112.115.116.114.101.97.109.54
= 13
docsLeakDetTestChannelStatusCurrCycleTime.90020.18.67.97.57.47.48.47.50.52.45.117.112.115.116.114.101.97.109.54
= 100

```

```
docsLeakDetTestChannelStatusCurrCycleTime.90021.18.67.97.57.47.48.47.51.48.45.117.112.115.116.114.101.97.109.54
= 20
docsLeakDetTestChannelStatusNumBurstPositions.90020.18.67.97.57.47.48.47.50.52.45.117.112.115.116.114.101.97.109.54
= 2
docsLeakDetTestChannelStatusNumBurstPositions.90021.18.67.97.57.47.48.47.51.48.45.117.112.115.116.114.101.97.109.54
= 3
```

The following are the input parameters for the **docsLeakDetTestChannelStatusTable** MIB:

- docsLeakDetTestSessionStatusSessionId
- docsLeakDetTestChannelStatusInterfaceName

The following are the output parameters for the **docsLeakDetTestChannelStatusTable** MIB.

**Table 142: Output Parameters**

| Output Parameters                             | Description                                                                                                                                                                                                                    |
|-----------------------------------------------|--------------------------------------------------------------------------------------------------------------------------------------------------------------------------------------------------------------------------------|
| docsLeakDetTestChannelStatusTestStartFreq     | Value of the actual SC frequency start.                                                                                                                                                                                        |
| docsLeakDetTestChannelStatusTestEndFreq       | Value of the actual SC frequency end.                                                                                                                                                                                          |
| docsLeakDetTestChannelStatusNumModemsCfg      | Number of modems configured under the burst session.                                                                                                                                                                           |
| docsLeakDetTestChannelStatusNumModemsActive   | Number of modems on which the burst session is activated.                                                                                                                                                                      |
| docsLeakDetTestChannelStatusFirstSubcarrierId | Lowest subcarrierId on the lowest edge of the first minislot that the CCAP has selected for testing of leakage.                                                                                                                |
| docsLeakDetTestChannelStatusLastSubcarrierId  | Highest subcarrierId on the highest edge of the last minislot that the CCAP has selected for testing of leakage.                                                                                                               |
| docsLeakDetTestChannelStatusBurstFluc         | The corresponding burstfluc that is used for leakage detection on the OFDMA channel.                                                                                                                                           |
| docsLeakDetTestChannelStatusCurrCycleTime     | If the cycle time is configured, observes the configured cycle time. If the cycle gap is configured, the estimated gap for the session is observed and adjusts it to a whole number (for example, 7.830 will be rounded to 8). |
| docsLeakDetTestChannelStatusNumBurstPositions | If you configure the cycle time, the burst positions takes the maximum burst position for the cycle time and the current burst position when configured with the cycle gap.                                                    |





## CHAPTER 42

# Time and Frequency Division Multiplexing Configuration

---

This document provides information on the Cisco cBR-8 series routers support for Time and Frequency Division Multiplexing (TaFDM) feature in DOCSIS 3.1 upstream channels.

- [Information About TaFDM Support, on page 701](#)
- [How to Configure cBR for TaFDM Support, on page 702](#)
- [Configuration Example , on page 704](#)
- [Feature Information for TaFDM Configuration, on page 705](#)

## Information About TaFDM Support

Using the Time and Frequency Division Multiplexing (TaFDM) method, the OFDMA and SCQAM channels, which are allowed to overlap in DOCSIS 3.1, are also allowed to use the upstream at different times. With the implementation of TaFDM, both OFDMA and SC-QAM can simultaneously operate on separate frequencies. They can also operate on the same frequencies, but in different times.

TaFDM enables the OFDMA capability across the entire spectrum, while retaining the backward compatibility with legacy DOCSIS SC-QAM channels.

TaFDM is typically configured at the controller level. However, it is implemented at the Mac Domain level. Overlapping channels cannot be bound to different Mac Domains.

Overlapping SC-QAM and OFDMA channels using TaFDM may be bonded. However, we recommend this bonding only if the modems are provisioned with UGS flows and another non-overlapping SC-QAM is not available.

For a better performance of UGS flows on overlapped SC-QAM channel, configure OFDMA channel with 50kHz subcarrier spacing, lower symbols per frame, and lower cyclic prefix.

To achieve a higher OFDMA channel traffic throughput, configure OFDMA channel with 25kHz subcarrier spacing, and higher pilot pattern.

## Prerequisites for Configuring TaFDM Support

The following prerequisite is applicable to configuring TaFDM configuration:

- All overlapped SC-QAM channels and OFDMA channels on the same port must be bound to the same Mac Domain
- Reserve a minimum 0.8–3.2 MHz OFDMA exclusive spectrum with good signal quality to be used for OFDMA channel IM zone

## How to Configure cBR for TaFDM Support

### Configuring TaFDM Modulation Profile

The TaFDM modulation profile is used to configure initial ranging, fine ranging and data IUC parameters. To define the TaFDM modulation profile, run the configuration commands, as given in the following example:

```
cable mod-profile-ofdma 450
  subcarrier-spacing 25KHz
  initial-rng-subcarrier 64
  fine-rng-subcarrier 192
  data-iuc 9 modulation 1024-QAM pilot-pattern 11
  data-iuc 10 modulation 512-QAM pilot-pattern 11
  data-iuc 11 modulation 256-QAM pilot-pattern 8
  data-iuc 12 modulation 128-QAM pilot-pattern 8
  data-iuc 13 modulation 64-QAM pilot-pattern 8

cable mod-profile-ofdma 470
  subcarrier-spacing 50KHz
  initial-rng-subcarrier 64
  fine-rng-subcarrier 192
  data-iuc 9 modulation 1024-QAM pilot-pattern 1
  data-iuc 10 modulation 512-QAM pilot-pattern 1
  data-iuc 11 modulation 256-QAM pilot-pattern 1
  data-iuc 12 modulation 128-QAM pilot-pattern 1
  data-iuc 13 modulation 64-QAM pilot-pattern 1
```

### Configuring I/O Controller for TaFDM

The following sample configuration defines a shared region in the areas of the SC-QAM upstream channels.

```
controller Upstream-Cable slot/subslot/port
  us-channel 0 frequency 35800000
  us-channel 0 channel-width 6400000 6400000
  us-channel 0 docsis-mode atdma
  us-channel 0 minislots-size 2
  us-channel 0 modulation-profile 221
  us-channel 0 equalization-coefficient
  no us-channel 0 shutdown
  us-channel 1 frequency 29400000
  us-channel 1 channel-width 6400000 6400000
  us-channel 1 docsis-mode atdma
  us-channel 1 minislots-size 2
  us-channel 1 modulation-profile 221
  us-channel 1 equalization-coefficient
  no us-channel 1 shutdown
  us-channel 2 frequency 23000000
  us-channel 2 channel-width 6400000 6400000
  us-channel 2 docsis-mode atdma
  us-channel 2 minislots-size 2
```

```

us-channel 2 modulation-profile 221
us-channel 2 equalization-coefficient
no us-channel 2 shutdown
us-channel 3 frequency 16600000
us-channel 3 channel-width 6400000 6400000
us-channel 3 docsis-mode atdma
us-channel 3 minislot-size 2
us-channel 3 modulation-profile 221
us-channel 3 equalization-coefficient
no us-channel 3 shutdown

```

## Enhancing OFDMA Channel Throughput

The following example shows how to enhance the OFDMA channel throughput:

```

controller Upstream-Cable 1/0/0
...
us-channel 12 docsis-mode ofdma
us-channel 12 subcarrier-spacing 25KHz
us-channel 12 modulation-profile 450
us-channel 12 frequency-range 10000000 85000000 #Overlap with SC-QAM channels
us-channel 12 initial-rng-frequency-start 50000000 # Specify the preferred start
frequency for IM zone
us-channel 12 cyclic-prefix 96 roll-off-period 64
us-channel 12 symbols-per-frame 9
no us-channel 12 shutdown

```

## Enhancing SC-QAM Channel UGS Flow Performance

The following example shows how to enhance the UGS flow performance of the SC-QAM channel:

```

controller Upstream-Cable 1/0/0
...
us-channel 12 docsis-mode ofdma
us-channel 12 subcarrier-spacing 50KHz
us-channel 12 modulation-profile 470
us-channel 12 frequency-range 10000000 85000000 #Overlap with SC-QAM channels
us-channel 12 initial-rng-frequency-start 50000000 #Specify the preferred frequency for
IM zone
us-channel 12 cyclic-prefix 96 roll-off-period 64
us-channel 12 symbols-per-frame 8
no us-channel 12 shutdown

```

## Configuring Cable Interface-MAC Domain

The following example shows how to configure a cable interface for MAC Domain:

```

interface Cable1/0/0
load-interval 30

upstream 0 Upstream-Cable 1/0/0 us-channel 0
upstream 1 Upstream-Cable 1/0/0 us-channel 1
upstream 2 Upstream-Cable 1/0/0 us-channel 2
upstream 3 Upstream-Cable 1/0/0 us-channel 3
upstream 6 Upstream-Cable 1/0/0 us-channel 12
cable upstream bonding-group 1
upstream 0
upstream 1

```

```

upstream 2
upstream 3
attributes 80000000
cable upstream bonding-group 2
upstream 0
upstream 1
upstream 2
upstream 3
upstream 6
attributes 80000000
cable bundle 1
cable sid-cluster-group num-of-cluster 2      #Maximize single modem throughput
cable sid-cluster-switching max-request 4
cable cm-status enable 3 6-11 16-18 20-27
cable privacy accept-self-signed-certificate

```

## Configuring Service Class

The following example shows how to configure service classes:

```

cable service class 198 name mega_up
cable service class 198 upstream
cable service class 198 max-concat-burst 16384
cable service class 198 max-rate 1000000000    # Maximize single modem throughput
cable service class 198 max-burst 250000
cable service class 198 priority 0
cable service class 198 peak-rate 0

```

## Excluding a Frequency Band from TaFDM

If you want the SC-QAM to exclusively use a specific frequency range, configure Cisco cBR to exclude the band using the following sample commands.

```

controller Upstream-Cable slot/subslot/port
cable frequency-exclusion-band 18700000 22100000

```

## Verifying TaFDM Configuration

The following example shows how to verify the TaFDM configuration:

```

# show controllers upstream-Cable slot/subslot/port us-channel uschan-number-in-controller

#show controllers upstream-Cable slot/subslot/port us-channel uschan-number-in-controller
cdm-ump

# show interfaces cable slot/subslot/port mac-scheduler uschan-number-in-mac-domain

```

## Configuration Example

### TaFDM Configuration

```

controller Upstream-Cable 1/0/0
us-channel 0 frequency 15000000

```

```

us-channel 0 channel-width 3200000 3200000
us-channel 1 frequency 22000000
us-channel 1 channel-width 6400000 6400000
us-channel 2 frequency 29000000
us-channel 2 channel-width 6400000 6400000
us-channel 3 frequency 36000000
us-channel 3 channel-width 6400000 6400000
us-channel 4 frequency 11000000
us-channel 4 channel-width 1600000 1600000
us-channel 12 frequency-range 14000000 85000000

```

## Feature Information for TaFDM Configuration

Use Cisco Feature Navigator to find information about the platform support and software image support. Cisco Feature Navigator enables you to determine which software images support a specific software release, feature set, or platform. To access Cisco Feature Navigator, go to the <https://cfng.cisco.com/> link. An account on the Cisco.com page is not required.



**Note** The following table lists the software release in which a given feature is introduced. Unless noted otherwise, subsequent releases of that software release train also support that feature.

**Table 143: Feature Information for for TaFDM Configuration**

| Feature Name        | Releases                 | Feature Information                                                              |
|---------------------|--------------------------|----------------------------------------------------------------------------------|
| TaFDM Configuration | Cisco IOS XE Fuji 16.7.1 | This feature was introduced on the Cisco cBR Series Converged Broadband Routers. |





## CHAPTER 43

# DOCSIS 3.1 Upstream Profile Selection

---

DOCSIS 3.1 introduces the concept of upstream profiles for OFDMA channels. This document describes how to configure the DOCSIS 3.1 Upstream Profile Selection on the Cisco cBR Series Converged Broadband Router.

Your software release may not support all the features that are documented in this module. For the latest feature information and caveats, see the release notes for your platform and software release. The Feature Information Table at the end of this document provides information about the documented features and lists the releases in which each feature is supported.

Use Cisco Feature Navigator to find information about platform support and Cisco software image support. To access Cisco Feature Navigator, go to <http://tools.cisco.com/ITDIT/CFN/>. An account on <http://www.cisco.com/> is not required.

- [Hardware Compatibility Matrix for the Cisco cBR Series Routers, on page 707](#)
- [Information about Upstream Profiles, on page 709](#)
- [How to Configure Upstream Profiles, on page 709](#)
- [Feature Information for Upstream Profile Selection, on page 717](#)

## Hardware Compatibility Matrix for the Cisco cBR Series Routers



---

**Note** The hardware components that are introduced in a given Cisco IOS-XE Release are supported in all subsequent releases unless otherwise specified.

---

Table 144: Hardware Compatibility Matrix for the Cisco cBR Series Routers

| Cisco CMTS Platform                    | Processor Engine                                                                                                                                                                                  | Interface Cards                                                                                                                                                                                                                                                                                                                                                                                                                                                                                                                                                                                                                                                                                                                                                                                 |
|----------------------------------------|---------------------------------------------------------------------------------------------------------------------------------------------------------------------------------------------------|-------------------------------------------------------------------------------------------------------------------------------------------------------------------------------------------------------------------------------------------------------------------------------------------------------------------------------------------------------------------------------------------------------------------------------------------------------------------------------------------------------------------------------------------------------------------------------------------------------------------------------------------------------------------------------------------------------------------------------------------------------------------------------------------------|
| Cisco cBR-8 Converged Broadband Router | <p><b>Cisco IOS-XE Release 16.5.1 and Later Releases</b></p> <p>Cisco cBR-8 Supervisor:</p> <ul style="list-style-type: none"> <li>• PID—CBR-SUP-250G</li> <li>• PID—CBR-CCAP-SUP-160G</li> </ul> | <p><b>Cisco IOS-XE Release 16.5.1 and Later Releases</b></p> <p>Cisco cBR-8 CCAP Line Cards:</p> <ul style="list-style-type: none"> <li>• PID—CBR-LC-8D30-16U30</li> <li>• PID—CBR-LC-8D31-16U30</li> <li>• PID—CBR-RF-PIC</li> <li>• PID—CBR-RF-PROT-PIC</li> <li>• PID—CBR-CCAP-LC-40G</li> <li>• PID—CBR-CCAP-LC-40G-R</li> <li>• PID—CBR-CCAP-LC-G2-R</li> <li>• PID—CBR-SUP-8X10G-PIC</li> <li>• PID—CBR-2X100G-PIC</li> </ul> <p>Digital PICs:</p> <ul style="list-style-type: none"> <li>• PID—CBR-DPIC-8X10G</li> <li>• PID—CBR-DPIC-2X100G</li> </ul> <p>Cisco cBR-8 Downstream PHY Module:</p> <ul style="list-style-type: none"> <li>• PID—CBR-D31-DS-MOD</li> </ul> <p>Cisco cBR-8 Upstream PHY Modules:</p> <ul style="list-style-type: none"> <li>• PID—CBR-D31-US-MOD</li> </ul> |



**Note** Do not use DPICs (8X10G and 2x100G) to forward IP traffic, as it may cause buffer exhaustion, leading to line card reload.

The only allowed traffic on a DPIC interface is DEPI, UEPI, and GCP traffic from the Cisco cBR-8 router to Remote PHY devices. Other traffic such as DHCP, SSH, and UTSC should flow via another router, since DPICs cannot be used for normal routing.



## Information about Upstream Profiles

A modulation profile is a list of interval usage codes (IUCs) that are defined for an OFDMA channel. Each IUC will have a modulation order and pilot pattern. Multiple IUCs within a modulation profile allow for different modulation orders on the same OFDMA channel. The CMTS can define multiple profiles for use in an OFDMA channel, where the profiles differ in the modulation orders assigned to each minislot.

You can use the following commands to view the profiles:

- To display the profiles associated with the cable modems (CMs), use the **show cable modem** *[ip-address/ mac-address/ cable/ {slot | subslot | cable-interface-index}] phy ofdm-profile upstream command.*
- To display detailed profile management data associated with specific cable modem, use the **show cable modem** *[ip-address/ mac-address] prof-mgmt upstream verbose* command.

The CMTS can assign different data IUCs for different groups of CMs.

A DOCSIS 3.1 CM can only have two active OFDMA Upstream Data Profile IUCs on a given channel.

## Default Data IUC

Data IUC 13 is intended to be the most robust IUC and able to be used by all cable modems.

## Recommended Interval Usage Code (IUC)

Based on the receive modulation error ratio (RxMER) values collected periodically during upstream probing, the CMTS finds among the existing IUCs up to two that provide the highest speed while having sufficient signal to noise ratio (SNR) margin for the CMTS to receive code words with acceptable error rates. The **show cable modem phy ofdm-profile upstream** command displays the one or two recommended IUCs for each CM.

In Cisco IOS XE Everest 16.6.1 release, data IUC 13 will be one of the IUCs assigned to the CM.

To disable the automatic profile downgrade, use **no cable upstream ofdma-prof-mgmt prof-upgrade-auto** command in global configuration mode.

## How to Configure Upstream Profiles

### Configuring RxMER to Bit Loading Mapping

There are many ways to map the Receive Modulation Error Ratio (RxMER) values to bit loading values. We use the following mapping recommended in DOCSIS 3.1 OSSI, as our baseline mapping:

| RxMER (in ¼ DB) | QAM | Bit Loading |
|-----------------|-----|-------------|
| 60              | 16  | 4           |
| 84              | 64  | 6           |

| RxMER (in ¼ DB) | QAM   | Bit Loading |
|-----------------|-------|-------------|
| 96              | 128   | 7           |
| 108             | 256   | 8           |
| 122             | 512   | 9           |
| 136             | 1024  | 10          |
| 148             | 2048  | 11          |
| 164             | 4096  | 12          |
| 184             | 8192  | 13          |
| 208             | 16384 | 14          |

- To configure a margin to adjust the RxMER to bit loading mapping, use the following command:

```
Router(config)# cable upstream ofdma-prof-mgmt mer-margin-qdb interval-in-minutes
```

This configured value (*quarter-DB*) is added to the RxMER values collected by CMTS before using the above mapping table, thus giving a user more control in selecting the recommended profiles.

- To specify the percentage of minislot average RxMER that can be ignored in the recommended profile calculation, use the following command:

```
Router(config)# cable upstream ofdma-prof-mgmt exempt-mslot-pct percent
```

This provides a way to specify the extent that the outliers can be ignored.

- To configure the RxMER poll interval, use the following command:

```
Router(config)# cable upstream ofdma-prof-mgmt rxmer-poll-interval interval-in-minutes
```

The CMTS uses upstream probing to collect RxMER data per CM. This occurs during registration and periodically thereafter. The collected RxMER data is averaged per minislot and used to compute the recommended IUCs for each CM.

The **no cable upstream ofdma-prof-mgmt rxmer-poll-interval** command sets the rxmer-poll-interval to 1440, which is the value to disable the feature. The rxmer data is also not displayed after disabling the feature.

## Configuring Codeword Error Threshold

Starting from Cisco IOS XE Gibraltar 16.12.1x release, user can configure a codeword error threshold above which the profile will be downgraded, that is, switch to a lower order QAM.

Compared with the existing profile management scheme, in which the RxMER is read at configured interval, and data IUC is upgraded or downgraded based on RxMER data and configurable criteria, using customized codeword error threshold has several benefits, including:

- React to noise within minimal time window to maintain service quality
- If IUC selected by RxMER causes errors, it can be downgraded quickly
- Downgrade interval is much shorter than RxMER interval

To configure the codeword error threshold, enable this feature first:

```
Router(config)# cable upstream ofdma-prof-mgmt downgrade enable
```

Then configure the minimum number of codewords required within downgrade interval to consider for downgrade:

```
Router(config)# cable upstream ofdma-prof-mgmt downgrade min-cws value
```

Use **show cable modem prof-mgmt upstream** to check whether this feature is enabled:

```
Router#show cable modem 4800.33ef.3dd2 prof-mgmt upstream
Upstream Profile Management Data:
MAC Address          : 4800.33ef.3dd2
Number of US Chan    : 1

Ucid                 : 6
RxMer Exempt Percent : 0
RxMer Margin qdB     : 0
RxMer Threshold Percent : 2
Start Sc             : 148
End Sc               : 1907
Num RxMER Measurement : 1908
Tx Time              : 0h:04m:50s ago
Rx Time              : 0h:04m:50s ago
MER Poll Period (min) : 5
Auto Profile Upgrade : Yes
Upgrd Dly Cnt (cur/cfg) : 0/1
Upgrd Dly rcmd IUC   : none
Recommended IUC      : 5
Current IUC          : 5
Downgrade IUC        : 6
RxMER send/recv count : 1/1
DBC                  : 1/1/0/0/0
                    (send/succeed/err/reject/timeout)
State                 : Ready
Profile Downgrade      : Enabled
Profile Downgrade count : 0
Interval good/cor/uncor : 294/93/0
Downgrade Check Time   : 0h:00m:14s ago
```

After a downgrade, Profile Downgrade count is updated in the command output:

```
Router#show cable modem 4800.33ef.3dd2 prof-mgmt upstream
Upstream Profile Management Data:
MAC Address          : 4800.33ef.3dd2
Number of US Chan    : 1

Ucid                 : 6
RxMer Exempt Percent : 0
RxMer Margin qdB     : 0
RxMer Threshold Percent : 2
Start Sc             : 148
End Sc               : 1907
Num RxMER Measurement : 1908
Tx Time              : 0h:00m:01s ago
Rx Time              : 0h:00m:01s ago
MER Poll Period (min) : 5
Auto Profile Upgrade : Yes
Upgrd Dly Cnt (cur/cfg) : 0/1
Upgrd Dly rcmd IUC   : none
Recommended IUC      : 6
Current IUC          : 6
Downgrade IUC        : 9
```

```

RxMER send/rcv count : 3/3
DEC                  : 2/1/0/0/0
                    (send/succeed/err/reject/timeout)
State                : MER Received
Profile Downgrade   : Enabled
Profile Downgrade count : 1
Interval good/cor/uncor : 222/0/119
Downgrade Check Time   : 0h:00m:03s ago
Holddown Time         : 0h:00m:03s ago

```

The **Holddown Time** will not be displayed in the command output anymore after the configured holddown time is expired. In the following example, after two downgrades, the holddown time was expired, an RxMER was read and checked, and the profile was upgraded back to 5.

```

Router#show cable modem 4800.33ef.3dd2 prof-mgmt upstream
Upstream Profile Management Data:
MAC Address          : 4800.33ef.3dd2
Number of US Chan    : 1

Ucid                 : 6
RxMer Exempt Percent : 0
RxMer Margin qdB     : 0
RxMer Threshold Percent : 2
Start Sc             : 148
End Sc               : 1907
Num RxMER Measurement : 1908
Tx Time              : 0h:03m:07s ago
Rx Time              : 0h:03m:07s ago
MER Poll Period (min) : 5
Auto Profile Upgrade : Yes
Upgrd Dly Cnt (cur/cfg) : 0/1
Upgrd Dly rcmd IUC   : none
Recommended IUC      : 5
Current IUC           : 5
Downgrade IUC        : 6
RxMER send/rcv count : 6/6
DEC                  : 4/4/0/0/0
                    (send/succeed/err/reject/timeout)
State                : Ready
Profile Downgrade   : Enabled
Profile Downgrade count : 2
Interval good/cor/uncor : 269/72/0
Downgrade Check Time   : 0h:00m:03s ago

```

## Downgrading to Partial Mode

Starting from Cisco IOS XE Gibraltar 16.12.1y release, user can configure a codeword error threshold above which the profile will be downgraded to partial mode, that is disable some of the OFDMA channels when the CM is currently using IUC13 due to MER or downgrade.

To configure the codeword error threshold, enable this feature first:

```
Router(config)# cable upstream ofdma-prof-mgmt downgrade enable
```

Then configure the threshold to consider for downgrading to partial mode:

```
Router(config)# cable upstream ofdma-prof-mgmt downgrade partial-threshold  
value
```

Use **show cable modem partial-mode** to check the reason for downgrading to partial mode:

```

Router#show cable modem 4800.33ef.3dd2 partial-mode
MAC Address      IP Address  I/F          MAC      Prim  RCC  UP-reason/
                State      Sid  ID  Failed-tcsf
81d.0f01.1e10   9.2.0.46   C1/0/0/p    w-online 1    1    0x10 / 0x20

Note: 0x01 = Ranging
      0x10 = CWErr Partial Mode
      0x11 = Both

```

## Configuring RxMER Downgrade

Comparing to the existing upstream profile managements mechanism, RxMER downgrade has the following benefits:

- Ability to downgrade to partial mode based only on RxMER data
- Configurable desired lowest acceptable IUC
- This allows IUC 13 modulation to be robust for registration and DBC
- Allow certain percentage of subcarriers under threshold
- Re-evaluate RxMER data at next poll interval
- Channel leaves partial-mode and uses recommended IUC when RxMER data is above threshold
- Works independently with codeword error downgrade

By default, RxMER downgrade is disabled, use the following command to enable this feature:

```
Router(config)# cable upstream ofdma-prof-mgmt downgrade rxmer-enable
```

Then configure the data IUC below which the OFDMA channel will be downgraded to partial mode, the default number is 13:

```
Router(config-ofdma-mod-profile)# ofdma-prof-mgmt downgrade rxmer min-iuc value
```

You can also configure the number of minislots that can be below minimum IUC and not trigger downgrade, the default number is 0:

```
Router(config)# cable upstream ofdma-prof-mgmt downgrade rxmer-exempt-mslot-pct value
```

The following example shows how to configure RxMER downgrade in cBR-8:

```

Router(config)# cable upstream ofdma-prof-mgmt rxmer-poll-interval 5
Router(config)# cable upstream ofdma-prof-mgmt prof-upgrade-auto
Router(config)# cable upstream ofdma-prof-mgmt downgrade rxmer-enable
Router(config)# cable mod-profile-ofdma 466
Router(config-ofdma-mod-profile)# subcarrier-spacing 25KHz
Router(config-ofdma-mod-profile)# initial-rng-subcarrier 64
Router(config-ofdma-mod-profile)# fine-rng-subcarrier 256
Router(config-ofdma-mod-profile)# data-iuc 5 modulation 1024-QAM pilot-pattern 8
Router(config-ofdma-mod-profile)# data-iuc 9 modulation 512-QAM pilot-pattern 8
Router(config-ofdma-mod-profile)# data-iuc 10 modulation 256-QAM pilot-pattern 8
Router(config-ofdma-mod-profile)# data-iuc 11 modulation 128-QAM pilot-pattern 8
Router(config-ofdma-mod-profile)# data-iuc 12 modulation 64-QAM pilot-pattern 8
Router(config-ofdma-mod-profile)# data-iuc 13 modulation 16-QAM pilot-pattern 8
Router(config-ofdma-mod-profile)# ofdma-prof-mgmt downgrade rxmer min-iuc 12

```

To display the count of profile partial downgrade, use the command as shown in the following example:

```

Router# show cable modem 4800.33ef.3dd2 prof-mgmt upstream
Upstream Profile Management Data :
MAC Address           : 4800.33ef.3dd2
Ucid                  : 6
Num RxMER Measurement : 1908
Tx Time               : 0h:00m:15s ago
Rx Time               : 0h:00m:15s ago
MER Poll Period      (min) : 5
Auto Profile Upgrade  : Yes
Recommended IUC       : 13
Current IUC           : 13
Downgrade IUC         : 13
RxMER send/recv count : 10/10
DBC                   : 0/0/0/0/0           (send/succeed/err/reject/timeout)
State                  : MER Received
Profile Downgrade Partial count : 1
mslot RxMER(in 1/4 dB):
# msMer    0   : B3B7B4B0 B5ADB1B1 A6A9A5A3 89867A66 3A2C4152 53525D59 595F5C5F 5F636366
# msMer    32  : 00000000 00000000 00000000 00000000 00000000 00000000 00000000 00000000
# msMer    64  : 00000000 00000000
SC RxMER Distribution (Excluded SCs are ignored):*: 2%
>44dB: ***** 10.00%
>42dB: ** 4.31%
>39dB: 0.86%
>36dB: 1.55%
>33dB: * 2.41%
>30dB: 1.29%
>27dB: ** 5.17%
>24dB: **** 8.27%
>21dB: * 3.96%
>18dB: 1.63%
>15dB: 1.20%
<15dB: ***** 59.31%
-----100
Percent of Subcarriers

```

## Manually Configuring OFDMA Modulation Profile Downgrade

Table 145: Feature History

| Feature Name                                            | Release Information          | Feature Description                                                                                                                                                                                                                                                                                                                                                                                                                                                                                                                                                                                                                                                                                  |
|---------------------------------------------------------|------------------------------|------------------------------------------------------------------------------------------------------------------------------------------------------------------------------------------------------------------------------------------------------------------------------------------------------------------------------------------------------------------------------------------------------------------------------------------------------------------------------------------------------------------------------------------------------------------------------------------------------------------------------------------------------------------------------------------------------|
| Manually Configuring OFDMA Modulation Profile Downgrade | Cisco IOS XE Dublin 17.12.1z | <p>With this release, you can downgrade to the desired interval usage codes (IUC), while configuring the codeword error threshold for a profile.</p> <p>The operator can configure the <b>data-iuc</b> <i>data-iuc-type modulation modulation pilot-pattern pilot-pattern-id cwerr-downgrade-iuc cwerr-downgrade-iuc</i> keyword under the <b>cable mod-profile-ofdma</b> command to enable this feature.</p> <p>The benefit of configuring this command is that you can skip the trial of multiple profiles until it reaches the final IUC13 profile and configure the exact downgrade that you need. The time taken to downgrade the profile to IUC13 is reduced as some profiles are skipped.</p> |

In releases before Cisco IOS XE Dublin 17.12.1z, when a cable modem encounter OFDMA FEC issues, the cBR-8 modem downgrades the assigned profile to the next viable profile based on modulation order. This can result in the trial of up to 7 profiles on the way to IUC13 for a serious issue. Each profile is assigned at the 10-second assessment interval. Downgrade IUC selection is calculated based on the next lowest bitload Data IUC, from the list of available IUCs,

Starting with Cisco IOS XE Dublin 17.12.1z, downgrade IUC selection can be performed as per the **cwerr-downgrade-iuc** configuration.

The process of downgrade IUC selection which calculates the next lower bitload Data IUC from the list of available IUCs, is still applicable if you do not configure **cwerr-downgrade-iuc** .

### Configuring OFDMA Modulation Profile Downgrade

Here is a sample configuration for manually configuring IUC downgrade:

```
Router# configure terminal
Router(config)# cable mod-profile-ofdma 461
Router(config-ofdma-mod-profile)# subcarrier-spacing 50KHz
Router(config-ofdma-mod-profile)# initial-rng-subcarrier 32
Router(config-ofdma-mod-profile)# fine-rng-subcarrier 100
Router(config-ofdma-mod-profile)#
data-iuc 5 modulation 1024-QAM pilot-pattern 1 cwerr-downgrade-iuc 10
Router(config-ofdma-mod-profile)#
data-iuc 6 modulation 512-QAM pilot-pattern 1 cwerr-downgrade-iuc 10
Router(config-ofdma-mod-profile)#
data-iuc 9 modulation 256-QAM pilot-pattern 2 cwerr-downgrade-iuc 13
Router(config-ofdma-mod-profile)# data-iuc 10 modulation 128-QAM pilot-pattern 2
cwerr-downgrade-iuc 13
Router(config-ofdma-mod-profile)#
data-iuc 11 modulation 64-QAM pilot-pattern 3 cwerr-downgrade-iuc 13
Router(config-ofdma-mod-profile)# data-iuc 12 modulation 32-QAM pilot-pattern 3
Router(config-ofdma-mod-profile)# data-iuc 13 modulation 16-QAM pilot-pattern 4
Router(config-ofdma-mod-profile)# end
```

Use this command to verify the **cwerr-downgrade-iuc** downgrade configuration for the upstream channel:

```
Router# show controllers upstream-Cable 1/0/14 us-channel 12
USPHY OFDMA support: FULL
```

```
Controller 1/0/14 upstream 12 AdminState:UP OpState: UP
ofdma mode enabled
Channel Freq Range 18.500 MHz to 28.500 MHz
Channel Subcarrier Index Range Cfg: 74, 273 Op: 74, 273
Channel SC0 Freq Cfg: 14.800 MHz Op: 14.800 MHz
#Excl bands: 2
( 0, 73), ( 274, 2047),
#Unused bands: 0
Cyclic Prefix Size 96, Rolloff Period Size 0
Subcarrier Spacing 50KHz, Symbols Per Frame 18 Subcarrier Per Minislot: 8
```

```
Modulation Profile (ID 461, Subcarrier Spacing 50KHz)
  IUC type  Cfg  Act  Preamble Bit  Pilot  Cwerr Downgrade
            subc subc Symbols Loading  Pattern  IUC
  3  (IR)   32   32    4      -      -      -
  4  (FR)  100  100    1      -      -      -
  5  (data) -    -    -    1024-QAM  1      10
  6  (data) -    -    -    512-QAM  1      10
```

## Display the Cable Modem Count per Profile

```

 9 (data) - - - 256-QAM 2 13
10 (data) - - - 128-QAM 2 13
11 (data) - - - 64-QAM 3 13
12 (data) - - - 32-QAM 3 -
13 (data) - - - 16-QAM 4 -
...
...
...

```

This sample shows a partial output of the command. The last column displays the configured **cwerr-downgrade-iuc** value.

Use this command to display the IUC for a specific modem:

```

Router# show cable modem XXXX.XXXX.XXXX prof-mgmt upstream
MAC Address          : XXXX.XXXX.XXXX
Number of US Chan    : 1
Ucid                 : 13
MD US Chan           : Cable0/0/14/U12
Ctrlr US Chan        : UC0/0/14:U12
...
...
...
Recommended IUC      : 5 (1024-QAM)
Current IUC          : 5 (1024-QAM)
Downgrade IUC       : 10 (128-QAM)
RxMER Recommended IUC : 5 (1024-QAM)
RxMER send/recv count : 20/20
RxMER retries curr/total: 0/0
Int tot/good/cor/uncor : 1003/1002/1/0 (18/0)
Downgrade Check Time  : 0h:00m:57s ago

```

This sample shows a partial output of the command. The line highlighted in bold (Downgrade IUC : 10 (128-QAM)) displays the configured **cwerr-downgrade-iuc** value.

## Display the Cable Modem Count per Profile

Feature History

**Table 146: Feature History**

| Feature Name                                | Release Information            | Feature Description                                                                                                                                                                                                                                                                                                                                       |
|---------------------------------------------|--------------------------------|-----------------------------------------------------------------------------------------------------------------------------------------------------------------------------------------------------------------------------------------------------------------------------------------------------------------------------------------------------------|
| Display CM counts per US IUC and DS profile | Cisco IOS XE Bengaluru 17.6.1x | This feature introduces new commands <b>show cable modem phy ofdm downstream prof-count</b> and <b>show cable modem phy ofdm upstream iuc-count</b> , it helps tracking and reporting number of Cable Modems being in use per Upstream IUC and Downstream Profile on each controller separately. These counters are indicative of health of the RF plant. |



To display the CM count per upstream port and IUC, use the **show cable modem phy ofdm upstream iuc-count** command as shown in the example below:

```
Router#show cable modem phy ofdm upstream iuc-count
|<-----> CM Count per profile ----->|
I/F          IF-INDX  IUC-5  IUC-6  IUC-9  IUC-10  IUC-11  IUC-12  IUC-13
-----
C1/0/0/U6    488046    3      0      0      0      0      0      3
C1/0/0/U7    488047    3      0      0      0      0      0      3
C9/0/0/U6    501870    1      0      0      0      0      0      1
C9/0/0/U7    501871    1      0      0      0      0      0      1
C9/0/1/U6    501918    1      0      0      0      0      0      2
C9/0/1/U7    501919    1      0      0      0      0      0      2
```

## Feature Information for Upstream Profile Selection

Use Cisco Feature Navigator to find information about the platform support and software image support. Cisco Feature Navigator enables you to determine which software images support a specific software release, feature set, or platform. To access Cisco Feature Navigator, go to the <https://cfmng.cisco.com/> link. An account on the Cisco.com page is not required.



**Note** The following table lists the software release in which a given feature is introduced. Unless noted otherwise, subsequent releases of that software release train also support that feature.

**Table 147: Feature Information for Upstream Profile Selection**

| Feature Name                   | Releases                        | Feature Information                                                                                                   |
|--------------------------------|---------------------------------|-----------------------------------------------------------------------------------------------------------------------|
| DOCSIS3.1 US Profile Selection | Cisco IOS XE Fuji 16.7.1        | This feature was integrated into Cisco IOS XE Fuji 16.7.1 on the Cisco cBR Series Converged Broadband Routers.        |
| Codeword Errors Monitoring     | Cisco IOS XE Gibraltar 16.12.1x | This feature was integrated into Cisco IOS XE Gibraltar 16.12.1x on the Cisco cBR Series Converged Broadband Routers. |
| Downgrading to Partial Mode    | Cisco IOS XE Gibraltar 16.12.1y | This feature was integrated into Cisco IOS XE Gibraltar 16.12.1y on the Cisco cBR Series Converged Broadband Routers. |
| RxMER Downgrade                | Cisco IOS XE Gibraltar 16.12.1z | This feature was integrated into Cisco IOS XE Gibraltar 16.12.1z on the Cisco cBR Series Converged Broadband Routers. |





# CHAPTER 44

## Proactive Network Management

This document describes how to configure the Proactive Network Management on the Cisco cBR Series Converged Broadband Router.

- [Hardware Compatibility Matrix for the Cisco cBR Series Routers](#), on page 719
- [Fast Fourier Transform](#), on page 720
- [Information about Proactive Network Management](#), on page 726
- [Proactive Network Management Using Upstream Triggered Spectrum Capture](#), on page 726
- [Proactive Network Management using OFDMA RxMER Probes](#), on page 773
- [Proactive Network Management using OFDMA RxPwr Probes](#), on page 777
- [Troubleshooting Proactive Network Management Issues](#), on page 789
- [Upstream External PMA](#), on page 790
- [Feature Information for Proactive Network Management](#), on page 814

## Hardware Compatibility Matrix for the Cisco cBR Series Routers



**Note** The hardware components that are introduced in a given Cisco IOS-XE release are supported in all subsequent releases unless otherwise specified.

**Table 148: Hardware Compatibility Matrix for the Cisco cBR Series Routers**

| Cisco CMTS Platform                    | Processor Engine                                                                                                                                                                                                                     | Interface Cards                                                                                                                                                                                |
|----------------------------------------|--------------------------------------------------------------------------------------------------------------------------------------------------------------------------------------------------------------------------------------|------------------------------------------------------------------------------------------------------------------------------------------------------------------------------------------------|
| Cisco cBR-8 Converged Broadband Router | <b>Cisco IOS-XE Release 3.15.0S and Later Releases</b><br>Cisco cBR-8 Supervisor: <ul style="list-style-type: none"><li>• PID—CBR-CCAP-SUP-160G</li><li>• PID—CBR-CCAP-SUP-60G<sup>3</sup></li><li>• PID—CBR-SUP-8X10G-PIC</li></ul> | <b>Cisco IOS-XE Release 3.15.0S and Later Releases</b><br>Cisco cBR-8 CCAP Line Cards: <ul style="list-style-type: none"><li>• PID—CBR-CCAP-LC-40G-R</li><li>• PID—CBR-CCAP-LC-80G-R</li></ul> |

- <sup>3</sup> Effective with Cisco IOS-XE Release 3.17.0S, CBR-CCAP-SUP-60G supports 8 cable line cards. The total traffic rate is limited to 60 Gbps. The total number of downstream service flows is limited to 72268, and downstream unicast low-latency flow does not count against the limits.

## Fast Fourier Transform

Table 149: Feature History

| Feature Name                              | Release Information          | Feature Description                                                                                                                                                                                                                                      |
|-------------------------------------------|------------------------------|----------------------------------------------------------------------------------------------------------------------------------------------------------------------------------------------------------------------------------------------------------|
| Fast Fourier Transform (FFT) Enhancements | Cisco IOS XE Dublin 17.12.1x | In this release, we have optimized legacy periodical FFT for both cBR-8 and RPD which helps in reducing system memory and CPU resources. Use the <code>cable rpd period-fft [ start   stop ]</code> command to start or stop RPD periodical FFT polling. |

In releases before Cisco IOS XE Dublin 17.12.1x, IOSd CLC sends periodical FFT polling requests to CDMAN every 300 milliseconds for an upstream channel. CDMAN then sends this poll request to RPHYMAN and RPHYMAN sends this poll request to RPD. Huge IPC messages between CDMAN and RPHYMAN, and GCP messages transactions between cBR-8 and RPD consume most of RPHYMAN memory and CPU resources. In a large-scale environment, RPDs drop offline during LCHA and SUPHA.

To solve the FFT consuming resource issue, we have optimized legacy periodical FFT for both cBR8 and RPD.

- cBR-8 send whole FFT configuration for all upstream channel to RPD side at the beginning bulk config and period FFT polling on IOSd CLC side is removed.
- CDMAN inserts the `sm-rng` interval in each map message for all upstream channels on CLC. After every 1-second interval, RPD reports FFT sample data to cBR-8, every 1 second for one upstream channel.
- When upstream channel state changes, from up to down, or down to up, or when upstream channel mac domain binding state changes, from bind to unbind, or unbind to bind, RPD is notified about the changes with different TLV operation: WRITE or DELETE.
- You can run multiple FFTs by configuring one port on the RPD to run CM MAC FFT while the other port on this RPD and other RPDs on this line card continue periodical FFT and other types FFT.

### Fast Fourier Transform Enhancements

The following changes are implemented in FFT to reduce memory and CPU resource consumption.

- The period FFT polling on the IOSd CLC side is removed. cBR-8 send whole FFT configuration for all upstream channels to the RPD side at the beginning bulk config.
- CDMAN inserts the `sm-rng` interval in each map message for all upstream channels on CLC. After every 1-second interval, RPD reports FFT sample data to cBR-8, every 1 second for one upstream channel.

- When upstream channel state changes, from up to down, or down to up, or when upstream channel mac domain binding state changes, from bind to unbind, or unbind to bind, RPD is notified about the changes with different TLV operation: WRITE or DELETE.
- In previous releases, if any RPD on the line card is running CM MAC FFT, then all other types of FFT are stopped for all RPDs on this line card. Starting with Cisco IOS XE Dublin 17.12.1x, you can configuring one port on RPD to run CM MAC FFT while the other port on this RPD and other RPDs on this line card continue periodical FFT and other types FFT.

### Priority of Different FFT Types

There are several types of FFT, and they are prioritized in the following order:

1. CM MAC
2. One Time FFT Request (CLI and SNMP)
3. Periodical FFT polling
  - When CM MAC is running on one upstream controller, one time FFT request and periodical FFT polling on the upstream channel of this controller is disabled.
  - When a one-time FFT request is issued, periodical FFT polling on the same upstream channel is disabled. When a one-time FFT response is received, periodical FFT polling on this upstream channel is enabled again.

### CM MAC Affection

As CM MAC has the highest priority, in previous releases, if any RPD on the line card is running CM MAC FFT, then all other types of FFT are stopped for all RPDs on this line card.

Starting with Cisco IOS XE Dublin 17.12.1x, we can make one port on RPD run CM MAC FFT while the other port on this RPD and other RPDs on this line card continue periodical FFT and other types FFT.

If multiple RPDs share the same upstream controller, and one RPD is running CM MAC on this controller, then all other RPDs sharing the same upstream controller must stop periodical FFT and one time FFT on the corresponding port using the same upstream controller.

### CLIs

#### • Periodical FFT Show Command

```
router#show cable signal-quality cable 2/0/1 cmts
I/F          CNiR          Expected Received      Device ID
              (dB)          Signal Power (dBmV)    US Sharing
Cable2/0/1/U0  57.0          0.0                    0
Cable2/0/1/U0  -----          -----                1
Cable2/0/1/U0  -----          -----                2
Cable2/0/1/U0  -----          -----                3
Cable2/0/1/U0  -----          -----                4
Cable2/0/1/U0  -----          -----                5
Cable2/0/1/U0  -----          -----                6
Cable2/0/1/U0  -----          -----                7
Cable2/0/1/U1  58.0          0.0                    0
Cable2/0/1/U1  -----          -----                1
Cable2/0/1/U1  -----          -----                2
Cable2/0/1/U1  -----          -----                3
Cable2/0/1/U1  -----          -----                4
```

```

Cable2/0/1/U1      -----      -----      5
Cable2/0/1/U1      -----      -----      6
Cable2/0/1/U1      -----      -----      7
Cable2/0/1/U2      55.0        0.0          0
Cable2/0/1/U2      -----      -----      1
Cable2/0/1/U2      -----      -----      2
Cable2/0/1/U2      -----      -----      3
Cable2/0/1/U2      -----      -----      4
Cable2/0/1/U2      -----      -----      5
Cable2/0/1/U2      -----      -----      6
Cable2/0/1/U2      -----      -----      7
Cable2/0/1/U3      56.0        0.0          0
Cable2/0/1/U3      -----      -----      1
Cable2/0/1/U3      -----      -----      2
Cable2/0/1/U3      -----      -----      3

```

### • One Time FFT Command – Spectrum Analyze Data

```

router#show cable spectrum-analysis cable 2/0/28 upstream 0 sid 14 devID 0
Spectrum Analysis Measurements for Cable2/0/28: Upstream 0 Sid 14
Device ID: 0
Channel Center Frequency: 11400 kHz
Frequency Span:          6400 kHz
Number of Bins:          257
Bin Spacing:             25.0 kHz
Resolution Bandwidth:    42.750 kHz
Amplitude Data:
  Bin  1: -35.00 dBmV
  Bin  2: -40.00 dBmV
  Bin  3: -32.00 dBmV
  Bin  4: -37.00 dBmV
  Bin  5: -30.00 dBmV
  Bin  6: -38.00 dBmV
  Bin  7: -28.00 dBmV
  Bin  8: -34.00 dBmV
  Bin  9: -27.00 dBmV
  Bin 10: -33.00 dBmV
  Bin 11: -30.00 dBmV
  Bin 12: -26.00 dBmV
  Bin 13: -25.00 dBmV
  Bin 14: -24.00 dBmV
  Bin 15: -22.00 dBmV
  Bin 16: -24.00 dBmV
  Bin 17: -26.00 dBmV
  .....
  Bin 249: -33.00 dBmV
  Bin 250: -34.00 dBmV
  Bin 251: -38.00 dBmV
  Bin 252: -43.00 dBmV
  Bin 253: -60.00 dBmV
  Bin 254: -60.00 dBmV
  Bin 255: -60.00 dBmV
  Bin 256: -60.00 dBmV
  Bin 257: -60.00 dBmV

```

### • One Time FFT Command – CM CNR

```

router#scm c0c6.87ff.cdd0 cnr
Load for five secs: 47%/4%; one minute: 57%; five minutes: 59%
Time source is NTP, 17:33:07.936 CST Fri Nov 17 2023
MAC Address      IP Address      I/F          MAC          State      Prim  ExPwr  RxPwr  cnr
                  (dBmV)         (dBmV)       (dB)
c0c6.87ff.cdd0  116.1.26.204   C1/0/0/U8    w-online(pt) 22    0.0    0.00  > 40
c0c6.87ff.cdd0  116.1.26.204   C1/0/0/U9    w-online(pt) 22    0.0    0.00  > 40
c0c6.87ff.cdd0  116.1.26.204   C1/0/0/U10   w-online(pt) 22    0.0    0.00  > 40

```

```

c0c6.87ff.cdd0 116.1.26.204 C1/0/0/U11 w-online(pt) 22 0.0 0.00 > 40
c0c6.87ff.cdd0 116.1.26.204 C1/0/0/U12 w-online(pt) 22 0.0 0.00 > 40
c0c6.87ff.cdd0 116.1.26.204 C1/0/0/U13 w-online(pt) 22 0.0 0.00 3
c0c6.87ff.cdd0 116.1.26.204 C1/0/0/U14 w-online(pt) 22 0.0 0.00 12
c0c6.87ff.cdd0 116.1.26.204 C1/0/0/U15 w-online(pt) 22 0.0 0.00 > 40

```



**Note** In new design, after one time CLI issued, we must wait 1s before sending the FFT request to RPD for each Upstream channel to make sure what we got is not periodical FFT packet.

So for the following command, for example, this modem has 8 upstream channels, the CLI response waiting time is at least 8s

```

router#scm c0c6.87ff.cdd0 cnr
Load for five secs: 47%/4%; one minute: 57%; five minutes: 59%
Time source is NTP, 17:33:07.936 CST Fri Nov 17 2023
MAC Address      IP Address      I/F      MAC      Prim
ExpPwr  RxPwr  cnr
State      Sid
(dBmV) (dBmV) (dB)
c0c6.87ff.cdd0 116.1.26.204 C1/0/0/U8 w-online(pt) 22
0.0 0.00 > 40
c0c6.87ff.cdd0 116.1.26.204 C1/0/0/U9 w-online(pt) 22
0.0 0.00 > 40
c0c6.87ff.cdd0 116.1.26.204 C1/0/0/U10 w-online(pt) 22
0.0 0.00 > 40
c0c6.87ff.cdd0 116.1.26.204 C1/0/0/U11 w-online(pt) 22
0.0 0.00 > 40
c0c6.87ff.cdd0 116.1.26.204 C1/0/0/U12 w-online(pt) 22
0.0 0.00 > 40
c0c6.87ff.cdd0 116.1.26.204 C1/0/0/U13 w-online(pt) 22
0.0 0.00 3
c0c6.87ff.cdd0 116.1.26.204 C1/0/0/U14 w-online(pt) 22
0.0 0.00 12
c0c6.87ff.cdd0 116.1.26.204 C1/0/0/U15 w-online(pt) 22
0.0 0.00 > 40

```

#### • Periodical FFT Start/Stop Command

```

router#cable rpd all period-fft ?
start Start periodical FFT polling
stop Stop periodical FFT polling

router#cable rpd all period-fft stop
Confirm to continue? [no]: yes

router#cable rpd slot 1 period-fft ?
start Start periodical FFT polling
stop Stop periodical FFT polling
router#cable rpd slot 1 period-fft start
Confirm to continue? [no]: yes

router#cable rpd 0004.9f32.0019 period-fft ?
start Start periodical FFT polling
stop Stop periodical FFT polling

router#cable rpd 0004.9f32.0019 period-fft stop
Confirm to continue? [no]: yes

router#cable rpd 3.160.10.17 period-fft ?
start Start periodical FFT polling

```

```

stop    Stop periodical FFT polling

router#cable rpd 3.160.10.17 period-fft start
Confirm to continue? [no]: yes

```

## Debug Commands

### FFT Debug Command –CBR side

On SUP IOSd, enable upstream controller or channel debug:

```

L02#debug upstream-Cable 9/0 controller 32 ?
  us-channel  US channel
  <cr>       <cr>

```

On line card IOSd, enable specsvl debug:

```
Slot-9-0#test cable specsvl set dbg_cdm debug
```

Access the line card linux/tmp directory, which contains a file that is named as specsvl\_fft\_log which record the debug logs of CDMAN.

```
[L02_SIP_9:/tmp]$ ls specsvl_fft_log
```

For line card IOSd debug, use the following command.

```
Slot-9-0#debug cable specsvl
```

Use the following command to check CM MAC packet status, the countdown should keep decreasing.

```

router#show cable card 2/0 us-triggered-spectrum uts-common
Port 32 Dev 0 configuration
  UTSCOM event      START
  client_id         1
  test_id           1
  port              32
  dev               0
  phys_chan         8126466
  logi_chan          3
  sac_index         1
  trigger-mode      6
  frequency         24200000
  span              6400000
  bins              4096
  window            4
  output            1
  repeat-period     50000
  duration           1000
  trigger-count     10000
  qual-center-freq  0
  qual-bw           5120000
  qual-threshld    -100
WBFFT Dev    port, devId, trig-mode,data-ready, packets on WBFFT dev, countdown:
wbfft dev 0: 32    0 6      1      8      9992
wbfft dev 1: 64    8 0      0      0      0
wbfft dev 2: 64    8 0      0      0      0
wbfft dev 3: 64    8 0      0      0      0
wbfft dev 4: 64    8 0      0      0      0
wbfft dev 5: 64    8 0      0      0      0
wbfft dev 6: 64    8 0      0      0      0
wbfft dev 7: 64    8 0      0      0      0
total packets:      8

```

### FFT Debug Command –CBR side



Use the following command to check whether FFT packet is increasing.

```
RPD#show bcm-register fft all 0 -----port number
FFT Start Ctrl [02060000] : 61
In Control [02060001] : 0246
Out Control[02060003] : 99
Timing Ctrl [02060004] : 00
Minislot Cnt [02060005] : 00000000
FFT SID [02060009] : 1FFF
LC_BYTE [0206000b] : 04
FFT MXR CTL [0206000c] : 8600
FFT FIRST WDW CF [0206000e] : 0920
FFT SCND WDW CF [02060010] : C660
FFT MIDL WDW CF [02060012] : 61E0
FFT Status [02060016] : 0206

FFT Chan Control [05180000] : 00000008
FFT Packet Count [05180004] : 00014A9C ----- capture cnt

increased means okay
FFT Error Count [05180008] : 00000017
FFT Overflow Cnt [0518000c] : 00000017
SCFFTS In Ctrl [d0000040] : 00000004
```



- 
- Note**
- In the command, **show bcm-register fft all 0**,  
0 indicated the port number.
  - In the output line, In Control [02060001] : 0246 ,  
02 indicates channel Number, and 46 indicates legacy FFT if 32 means CM MAC.
  - In the output line, FFT Packet Count [05180004] : 00014A9C  
this value indicates the capture count. If it has increased, it indicates it is fine.
- 

Use the following command to check whether CM MAC is running and whether periodical FFT is disabled or not.

```
RPD#show bcm-register fft configuration 0
* NOTE: CM MAC configuration *

Enable CMMAC : True
SAC Index : 1
Channel Index : 0
Sid : 2
Trigger Count : 30000

RPD#show bcm-register fft configuration 1
* NOTE: legacy fft db configuration *

Port ID Chan ID Sid Frequency IUC Disable
1 0 8191 11400000 4 N
1 1 8191 17800000 4 N
1 2 8191 24200000 4 N
1 3 8191 30600000 4 N
```

## Information about Proactive Network Management

Proactive Network Management (PNM) enables you to measure and report conditions in the network. The PNM detects, identifies, and quantifies undesired impacts to the network, such as cable faults and ingress noise. The DOCSIS 3.1 PHY specification defines the different types of tests and measurements that can be performed at CCAP and CM. You can leverage this information to make the necessary modifications that can improve conditions and monitor networking trends to detect when network improvements are needed.

The PNM tests and receives data output from the CMTS using the Simple Network Management Protocol (SNMP) objects. The PNM feature is supported on RPHY.

## Proactive Network Management for Supervisor High Availability, Line Card High Availability and containers

PNM Supervisor High Availability support ensures that all captures are stopped and all the captures states in the Line Card and Supervisor client are cleaned up when Supervisor High Availability happens. You can create new capture configurations and initiate tests on the newly active supervisor through SNMP.

cBR supports Line Card High Availability and Line Card Process Restart for Proactive Network Management, and will support the restart of any test in progress.

Active syncing of capture data between active and standby SUP is not supported for Proactive Network Management. After switchover, all new captures must be configured by the user/client again.

Bulk Data Transfer MIBs enables configuration of the following parameters for PNM:

- TFTP server bulk data transfer IP address
- TFTP server bulk data transfer path

## Proactive Network Management Using Upstream Triggered Spectrum Capture

Cisco cBR-8 supports Upstream Triggered Spectrum Capture (UTSC). The upstream triggered spectrum analysis measurement provides a wideband spectrum analyzer in the CCAP which can be triggered to examine upstream transmissions and underlying noise or interference during a quiet period.

The Cisco cBR-8 supports the following Upstream Triggered Spectrum Capture objects:

- `UsTriggeredSpectrumCaptureFile`
- `UsTriggeredSpectrumCaptureCfg`
- `UsTriggeredSpectrumCaptureCtrl`
- `UsTriggeredSpectrumCaptureStatus`
- `UsTriggeredSpectrumCaptureCapabilities`
- `CCAPBulkDataControl`

The Cisco cBR-8 router enables you to trigger a spectrum sample capture and perform spectrum-analysis using the FreeRun mode. FreeRun mode is a continuous-mode with a maximum of 10 samples per second stacked on each capture file).

The CCAP supports one client configuration per port on a line card. Create a capture configuration entry before attempting to start or stop the capture tests. The interface index key for the `UsTriggeredSpectrumCaptureCfg` object defines the one capture configuration for the FreeRun trigger mode.

The Cisco cBR-8 supports only one capture per end-user client per port simultaneously. Hence, the CCAP sets the Upstream Triggered Spectrum Capture configuration index to 1. The Cisco cBR-8 does not support a PNM MIB query for an Upstream Triggered Spectrum Capture configuration index other than 1. The Cisco cBR-8 supports a maximum of eight captures on upstream ports per line card. The Cisco cBR-8 supports a maximum of 20 captures per router for RPHY.

The Cisco cBR-8 does not support the following scenarios:

- `UsTriggeredSpectrumCaptureResult` MIB
- Simultaneous captures on adjacent ports on CLC
- RPD support captures only one us-port per RPD at a given time.
- `docsPnmCmtsUtscCfgFilename` OID



**Note** The `UsTriggeredSpectrumCaptureConfiguration` MIB is supported. The `docsPnmCmtsUtscCfgFilename` OID under this MIB is not supported only for UTSC capture mode for PNM.

The PNM IOX container is used for the TFTP transfer of capture files to a user configured destination server. The **guestshell** IOX container for TFTP transfer of PNM files is supported. The PNM executable is built into the guestshell that is packaged as part of cbr8 image. This executable must be installed on both active and standby SUP manually.

Starting with Cisco IOS XE Dublin 17.12.1, the guestshell supports multiple BDTs. You can configure guestshell for IPv4 in all UTSC modes. For UTSC Other trigger mode, you can configure only in IPv6.

**Step 1** Ensure that the guestshell container is running before the captures are started to ensure successful TFTP operation. Use the **show app-hosting list** command to check if the guestshell container is running.

**Example:**

```
Router# show app-hosting list
App id                               Stat
-----
guestshell                            RUNNING
```

**Step 2** The app-hosting CLI is used to install, deploy, start, and stop the IOX container.

**Example:**

```
Router# show run | begin app-hosting
app-hosting appid guestshell
app-vnic gateway0 virtualportgroup 4 guest-interface 0
guest-ipaddress 9.32.254.2 netmask 255.255.255.0
app-default-gateway 9.32.254.1 guest-interface
```

**Step 3** Ensure that the python is running on the guestshell container.

**Example:**

```
cBR8#guestshell run python -V
Python 2.7.5
```

**Step 4** Ensure that the PNM TFTP process is active and running on the guestshell container.

**Example:**

```
cBR8#guestshell run systemctl status pnm
pnm.service - cbr pnm telemetry delivery system
   Loaded: loaded (/etc/systemd/system/pnm.service; disabled; vendor preset: disabled)
   Active: active (running) since Wed 2019-01-09 15:13:40 UTC; 9min ago
```

The PNM capture tests generate files to report measurements or test results. The results file includes header information that is common to all types of PNM tests and fields. The file also includes data that is specific to the type of PNM test. The abstract `PnmCaptureFile` object defines the attributes and format of the header information common to all PNM test files. File header fields are right-justified within the field and left-padded with zero values if necessary.

The following fields define the header for the `PnmCaptureFile` object for Upstream Spectrum Triggered Capture tests.

- **FileType** - A four-byte hexadecimal identifier specific to the type of PNM test that generated the data file.  
For Upstream Triggered Spectrum Capture, the file type is 0x504e4e6a.
- **Major Version** - This attribute represents the file header version. This value is incremented by one when the header format is modified by this specification.  
For Upstream Triggered Spectrum Capture, major version is 0x1.
- **Minor Version** - This attribute is reserved for vendor-specific and vendor-defined version information.  
For Upstream Triggered Spectrum Capture, minor version is 0x0.
- **CaptureTime** - This attribute represents the epoch time (also known as 'UNIX time') which is the number of seconds that have elapsed since midnight Coordinated Universal Time (UTC), Thursday, 1 January 1970.
- **IfIndex** - This attribute represents the ifIndex of the upstream RF port sampled.
- **UniqueCcapId** - A 256-byte hexadecimal field representing a unique CCAP identifier (either a loopback address (IPv4 or IPv6) or FQDN). This value is a null-terminated string.  
For Upstream Triggered Spectrum Capture, this value is the 'hostname' of the CMTS.

## Proactive Network Management Interface Index

To determine which slot/subslot/port of an ifindex translates to that of RPHY, see the mapping in the running configuration.

### Before you begin

The Upstream Triggered Spectrum Capture – The Cisco cBR-8 router supports multiple RPDs per line card with multiple US-ports. However, on RPDs, you can configure only one US-port and initiate the captures anytime.

For RPHY, it is not mandatory that the US port is bound to a MAC domain. If it is configured under an RPD, it can be configured for PNM.

The SNMP ifindex for MIB objects can be obtained using the show CLI:

```
Router# show snmp mib ifmib ifindex | i 0053.0013.2be0
RPD(0053.0013.2be0)-usport0: Ifindex = 435564
```

where 0053.0013.2be0 is the RPD identifier.

---

**Step 1** Run the following show command to identify the SNMP ifindex value:

```
Router# show snmp mib ifmib ifindex | i 435564
RPD(0053.0013.2be0)-usport0: Ifindex = 435564
```

**Step 2** Run the following command to identify the slot/subslot/port an ifindex that translates to RPHY:

```
Router# show run | b 0053.0013.2be0
identifier 0053.0013.2be
core-interface Tel1/1/0
principal
rpd-ds 0 downstream-cable 1/0/2 profile 2
rpd-us 0 upstream-cable 1/0/2 profile 21
```

---

The slot/subslot/port is upstream-cable 1/0/2 profile 21.



**Note** Cisco IOS XE Gibraltar 16.10.1g introduces an RPHY ifIndex change. Ensure that you have gone through the following updates to enable the changes:

- The RPHY ifIndex feature removes the Cisco private ifIndex for RPHY channels (ifIndex starting from 41,000). The ifIndex are not created manually. All the ifIndex are created automatically when configuring RPD. It is applicable for ifIndex starting from 41w for US (if-type 205) and DS (if-type 128). The RPHY ifIndex feature does not work for ifIndex values that are greater than 41w.

Before the ifIndex feature, in 16.10.1f and earlier releases:

```
Router# show snmp mib ifmib ifindex | i RPD
Upstream-Cable3/0/63:0-RPD(0053.0013.420c)-usport0: Ifindex = 421224
.....
RPD(0053.0013.420c)-usport0: Ifindex = 435560
RPD(0053.0013.420c)-dsport0: Ifindex = 436584
Downstream-Cable3/0/31:0-RPD(0053.0013.420c)-dsport0: Ifindex = 437608
Downstream-Cable3/0/31:1-RPD(0053.0013.420c)-dsport0: Ifindex = 437609
```

With the ifIndex feature, in 16.10.1g:

```
Router# show snmp mib ifmib ifindex | s RPD
RPD(0053.0013.420c)-usport0: Ifindex = 415080
RPD(0053.0013.420c)-dsport0: Ifindex = 416104
```

- The RPHY ifIndex reimplement CoreToRpdMap/RpdToCoreMap tables to keep them aligned with DOCS-RPHY-MIB-2018-07-26 definition.

You do not need to create a new ifIndex for US (if-type 205) and DS (if-type 128) channels when they are configured to RPD. For versions before Cisco IOS XE Gibraltar 16.10.1g, it was required to create a new ifIndex (>41k) for US (if-type 205) and DS (if-type 128) channels when they are configured to RPD:

```
[CBR]#show snmp mib ifmib ifindex | s RPD
RPD(0053.0013.420c)-usport0: Ifindex = 415080
RPD(0053.0013.420c)-dsport0: Ifindex = 416104
```

With the Cisco cBR-8 16.10.1g RPHY ifIndex feature, you do not need to manually populate any extra item in legacy MIBs.

With the Cisco cBR-8 16.10.1g RPHY ifIndex feature, you must reimplement docsRphyRpdIfCoreToRpdMapTable / docsRphyRpdIfRpdToCoreMapTable, not mapping to ifIndex (>41k) for US (if-type 205) and DS (if-type 128). See the following:

```
/* docsRphyRpdIfCoreToRpdMapRpdRfChanType OID :1.3.6.1.4.1.4491.2.1.30.1.2.6.1.5
   Table Index: docsRphyRpdIfCoreToRpdMapRpdCoreIndex, docsRphyRpdIfCoreToRpdMapRpdUniqueId,
   docsRphyRpdIfCoreToRpdMapRpdRfPortDirection, docsRphyRpdIfCoreToRpdMapRpdRfPortIndex*/
SNMPv2-SMI::enterprises.4491.2.1.30.1.2.6.1.5.403561.0.4.159.51.0.145.2.0 = INTEGER:
usAtdma(5)
SNMPv2-SMI::enterprises.4491.2.1.30.1.2.6.1.5.322358.0.4.159.51.0.145.1.0 = INTEGER:
dsScQam(1)
IF-MIB::ifType.403561 = INTEGER: docsCableUpstream(129)
IF-MIB::ifType.322358 = INTEGER: other(1)
```

```
[CBR]#show snmp mib ifmib ifindex
Cable9/0/0-upstream1: Ifindex = 403561
Downstream-Cable9/0/4-downstream14: Ifindex = 322358
```

- If RfChanType is usAtdma(5), ifType of docsRphyRpdIfCoreToRpdMapRpdCoreIndex is ifType docsCableUpstream(129)
- If RfChanType is dsScQam(1), ifType of docsRphyRpdIfCoreToRpdMapRpdCoreIndex is other(1).

## Upstream Triggered Spectrum Capture Configuration Parameters

The following configuration parameters for Upstream Triggered Spectrum Capture are supported. Examples of using the MIBs are also included.



**Note** PNM capture configuration on cBR8 is supported only through SNMP user interface. Configuration examples for MIB commands for PNM are provided in the following sections with examples using both snmpr (setany/getone commands) as well as net-snmp tools (snmpset/snmpget commands).

### Upstream Triggered Spectrum Capture Configuration Objects

The following Upstream Triggered Spectrum Capture configuration objects are supported:

- PNM UTSC OBJECTS OID: 1.3.6.1.4.1.4491.2.1.27.1.3.10
- PNM UTSC CAPTURE CONFIGURATION OID: 1.3.6.1.4.1.4491.2.1.27.1.3.10.2.1.X.Y.Z

Where X is the capture config parameter, Y is Ifindex, and Z is the PNM UTSC Config Index – Which is always 1. Currently only one capture configuration per upstream port is supported.

- The following capture configuration parameters are supported, and the corresponding MIB OID value is listed.

**Table 150: Supported capture configuration parameters and the corresponding MIB OID value**

| Capture configuration parameters      | Corresponding MIB OID value           |
|---------------------------------------|---------------------------------------|
| I_docsPnmCmtsUtscCfgTriggerMode       | 1.3.6.1.4.1.4491.2.1.27.1.3.10.2.1.3  |
| I_docsPnmCmtsUtscCfgCmMacAddr         | 1.3.6.1.4.1.4491.2.1.27.1.3.10.2.1.6  |
| I_docsPnmCmtsUtscCfgCenterFreq        | 1.3.6.1.4.1.4491.2.1.27.1.3.10.2.1.8  |
| I_docsPnmCmtsUtscCfgSpan              | 1.3.6.1.4.1.4491.2.1.27.1.3.10.2.1.9  |
| I_docsPnmCmtsUtscCfgNumBins           | 1.3.6.1.4.1.4491.2.1.27.1.3.10.2.1.10 |
| I_docsPnmCmtsUtscCfgAveraging         | 1.3.6.1.4.1.4491.2.1.27.1.3.10.2.1.11 |
| I_docsPnmCmtsUtscCfgQualifyCenterFreq | 1.3.6.1.4.1.4491.2.1.27.1.3.10.2.1.13 |
| I_docsPnmCmtsUtscCfgQualifyBw         | 1.3.6.1.4.1.4491.2.1.27.1.3.10.2.1.14 |
| I_docsPnmCmtsUtscCfgQualifyThrshld    | 1.3.6.1.4.1.4491.2.1.27.1.3.10.2.1.15 |
| I_docsPnmCmtsUtscCfgWindow            | 1.3.6.1.4.1.4491.2.1.27.1.3.10.2.1.16 |
| I_docsPnmCmtsUtscCfgOutputFormat      | 1.3.6.1.4.1.4491.2.1.27.1.3.10.2.1.17 |
| I_docsPnmCmtsUtscCfgRepeatPeriod      | 1.3.6.1.4.1.4491.2.1.27.1.3.10.2.1.18 |
| I_docsPnmCmtsUtscCfgFreeRunDuration   | 1.3.6.1.4.1.4491.2.1.27.1.3.10.2.1.19 |
| I_docsPnmCmtsUtscCfgTriggerCount      | 1.3.6.1.4.1.4491.2.1.27.1.3.10.2.1.20 |

| Capture configuration parameters | Corresponding MIB OID value           |
|----------------------------------|---------------------------------------|
| I_docsPnmCmtsUtscCfgStatus       | 1.3.6.1.4.1.4491.2.1.27.1.3.10.2.1.21 |

Starting from Cisco IOS XE Gibraltar 16.12.1x release, PNM output format 'timeIQ' and UTSC trigger mode 'cmMac' are supported in upstream triggered spectrum capture configuration objects.

Below is an example of the SNMP command configuration with PNM output format 'timeIQ' and UTSC trigger mode 'cmMac'.

```
snmpset -v2c -c private 10.74.54.13 1.3.6.1.4.1.4491.2.1.27.1.1.1.2.0 x "0B 01 01 0C"
snmpset -v2c -c private 10.74.54.13 1.3.6.1.4.1.4491.2.1.27.1.1.1.3.0 s "path"

snmpset -v2c -c private 10.74.54.13 1.3.6.1.4.1.4491.2.1.27.1.3.10.2.1.21.415084.1 i 6
snmpset -v2c -c private 10.74.54.13 1.3.6.1.4.1.4491.2.1.27.1.3.10.2.1.21.415084.1 i 4
snmpset -v2c -c private 10.74.54.13 1.3.6.1.4.1.4491.2.1.27.1.3.10.2.1.2.415084.1 i ifindex
snmpset -v2c -c private 10.74.54.13 1.3.6.1.4.1.4491.2.1.27.1.3.10.2.1.3.415084.1 i 6
snmpset -v2c -c private 10.74.54.13 1.3.6.1.4.1.4491.2.1.27.1.3.10.2.1.6.415084.1 x "CM
MAC"
snmpset -v2c -c private 10.74.54.13 1.3.6.1.4.1.4491.2.1.27.1.3.10.2.1.8.415084.1 u 16400000
snmpset -v2c -c private 10.74.54.13 1.3.6.1.4.1.4491.2.1.27.1.3.10.2.1.9.415084.1 u 6400000
snmpset -v2c -c private 10.74.54.13 1.3.6.1.4.1.4491.2.1.27.1.3.10.2.1.10.415084.1 u 1024
snmpset -v2c -c private 10.74.54.13 1.3.6.1.4.1.4491.2.1.27.1.3.10.2.1.11.415084.1 u 245
snmpset -v2c -c private 10.74.54.13 1.3.6.1.4.1.4491.2.1.27.1.3.10.2.1.13.415084.1 u 10240000
snmpset -v2c -c private 10.74.54.13 1.3.6.1.4.1.4491.2.1.27.1.3.10.2.1.14.415084.1 u 25600000
snmpset -v2c -c private 10.74.54.13 1.3.6.1.4.1.4491.2.1.27.1.3.10.2.1.15.415084.1 i -200
snmpset -v2c -c private 10.74.54.13 1.3.6.1.4.1.4491.2.1.27.1.3.10.2.1.16.415084.1 i 3
snmpset -v2c -c private 10.74.54.13 1.3.6.1.4.1.4491.2.1.27.1.3.10.2.1.17.415084.1 i 1
snmpset -v2c -c private 10.74.54.13 1.3.6.1.4.1.4491.2.1.27.1.3.10.2.1.18.415084.1 u 25000
snmpset -v2c -c private 10.74.54.13 1.3.6.1.4.1.4491.2.1.27.1.3.10.2.1.19.415084.1 u 5000
snmpset -v2c -c private 10.74.54.13 1.3.6.1.4.1.4491.2.1.27.1.3.10.2.1.20.415084.1 u 500
snmpset -v2c -c private 10.74.54.13 1.3.6.1.4.1.4491.2.1.27.1.3.10.2.1.21.415084.1 i 1
snmpset -v2c -c private 10.74.54.13 1.3.6.1.4.1.4491.2.1.27.1.3.10.3.1.1.415084.1 i 1
```

## Upstream Triggered Spectrum Capture Configuration MIB Objects

The following Upstream Triggered Spectrum Capture configuration MIB objects are supported for PNM:

- `CaptureCfg` – Contains the test trigger mode and its required configuration.
- `CaptureCtrl` – Controls when the test is started and stopped.
- `CaptureStatus` – Contains the current status of the test.
- `CaptureCapability` – Exposes CCAP Upstream Triggered Spectrum Capture capabilities.

The following Upstream Triggered Spectrum Capture configuration MIBs are supported. SNMP walk is supported for all the MIB objects.

- `docsPnmCmtsUtscCfgTriggerMode` - This attribute indicates which upstream triggered spectrum capture function trigger modes are supported. Only FreeRun is supported.

Starting with Cisco IOS XE Dublin 17.12.1, UTSC supports three trigger modes: FreeRun, Other, and CM-MAC.

The following are the enumerated values for trigger mode for PNM.

- `D_docsPnmCmtsUsSpecAnTrigMode_other` 1
- `D_docsPnmCmtsUsSpecAnTrigMode_freeRunning` 2



- D\_docsPnmCmtsUsSpecAnTrigMode\_sid 4
- D\_docsPnmCmtsUsSpecAnTrigMode\_idleSid 5
- D\_docsPnmCmtsUsSpecAnTrigMode\_minislotNumber 6
- D\_docsPnmCmtsUsSpecAnTrigMode\_cmMac 6

- For FreeRun mode, the CCAP initiates sampling and continues sampling until the time duration configured in the attribute FreeRunDuration has transpired. Sampling terminates when the time duration configured in FreeRunDuration has elapsed or when FFT is disabled. The interval between captures is the greater of RepeatPeriod and the minimum period that is supported by the CCAP.
- From Cisco IOS XE Gibraltar 16.12.1x release, PNM output format 'timeIQ' and UTSC trigger mode 'cmMac' are supported in upstream triggered spectrum capture configuration objects.
- Trigger mode set and get examples:

- **snmpr** commands:

```

server > setany -v2c <cmts_ip> <community_name>
1.3.6.1.4.1.4491.2.1.27.1.3.10.2.1.3.<ifIndex>.1 -i 2
clabProjDocsis.27.1.3.10.2.1.3.<ifIndex>.1 = 2

server > getone -v2c <cmts_ip> <community_name>
1.3.6.1.4.1.4491.2.1.27.1.3.10.2.1.3.<ifIndex>.1
clabProjDocsis.<ifIndex> = 2

```

- **net-snmp** commands:

```

server > snmpset -v2c -c <community_name> <cmts_ip>
1.3.6.1.4.1.4491.2.1.27.1.3.10.2.1.3.<ifIndex>.1 i 2
SNMPv2-SMI::enterprises.4491.2.1.27.1.3.10.2.1.3.<ifIndex>.1 = INTEGER: 2

server > snmpget -v2c -c <community_name> <cmts_ip>
1.3.6.1.4.1.4491.2.1.27.1.3.10.2.1.3.<ifIndex>.1
SNMPv2-SMI::enterprises.4491.2.1.27.1.3.10.2.1.3.<ifIndex>.1 = INTEGER: 2

```

- docsPnmCmtsUtscCfgCenterFreq - This attribute specifies the center frequency of the upstream spectrum to be sampled for analysis.

- **snmpr** commands:

```

server > setany -v2c <cmts_ip> <community_name>
1.3.6.1.4.1.4491.2.1.27.1.3.10.2.1.8.<ifIndex>.1 -g 102400000
clabProjDocsis.27.1.3.10.2.1.8.<ifIndex> = 102400000

server > getone -v2c <cmts_ip> <community_name>
1.3.6.1.4.1.4491.2.1.27.1.3.10.2.1.8.<ifIndex>.1
clabProjDocsis.27.1.3.10.2.1.8.<ifIndex>.1 = 102400000

```

- **net-snmp** commands:

```

server > snmpset -v2c -c <community_name> <cmts_ip>
1.3.6.1.4.1.4491.2.1.27.1.3.10.2.1.8.<ifIndex>.1 u 102400000
SNMPv2-SMI::enterprises.4491.2.1.27.1.3.10.2.1.8.<ifIndex>.1 = Gauge32: 102400000

server > snmpget -v2c -c <community_name> <cmts_ip>
1.3.6.1.4.1.4491.2.1.27.1.3.10.2.1.8.<ifIndex>.1
SNMPv2-SMI::enterprises.4491.2.1.27.1.3.10.2.1.8.<ifIndex>.1 = Gauge32: 102400000

```

- `docsPnmCmtsUtscCfgSpan` - This attribute determines the frequency span of the upstream spectrum sample capture. When this attribute is read, it provides the actual span, which may be different from the requested (configured) span due to implementation effects.

- **snmp** commands:

```
server > setany -v2c <cmts_ip> <community_name>
1.3.6.1.4.1.4491.2.1.27.1.3.10.2.1.9.<ifIndex>.1 -g 204800000
clabProjDocsis.27.1.3.10.2.1.9.<ifIndex>.1 = 204800000

server > getone -v2c <cmts_ip> <community_name>
1.3.6.1.4.1.4491.2.1.27.1.3.10.2.1.9.<ifIndex>.1
clabProjDocsis.27.1.3.10.2.1.9.<ifIndex>.1 = 204800000
```

- **net-snmp** commands:

```
server > snmpset -v2c -c <community_name> <cmts_ip>
1.3.6.1.4.1.4491.2.1.27.1.3.10.2.1.9.<ifIndex>.1 u 204800000
SNMPv2-SMI::enterprises.4491.2.1.27.1.3.10.2.1.9.<ifIndex>.1 = Gauge32: 204800000

server > snmpget -v2c -c <community_name> <cmts_ip>
1.3.6.1.4.1.4491.2.1.27.1.3.10.2.1.9.<ifIndex>.1
SNMPv2-SMI::enterprises.4491.2.1.27.1.3.10.2.1.9.<ifIndex>.1 = Gauge32: 204800000
```



---

**Note** The center frequency and span capture parameters are set to zero as per OSSI specifications on capture configuration entry creation. For freerun trigger mode, you must set these values in the valid range to run capture tests on the port.

---

- `docsPnmCmtsUtscCfgNumBins` - This attribute determines the number of frequency bins or samples per span when sampling the upstream spectrum. This attribute provides the actual number of bins, which may be different from the configured number due to implementation effects.

- **snmp** commands

```
server > setany -v2c <cmts_ip> <community_name>
1.3.6.1.4.1.4491.2.1.27.1.3.10.2.1.10.<ifIndex>.1 -g 4096
clabProjDocsis.27.1.3.10.2.1.10.<ifIndex>.1 = 4096

server > getone -v2c <cmts_ip> <community_name>
1.3.6.1.4.1.4491.2.1.27.1.3.10.2.1.10.<ifIndex>.1
clabProjDocsis.27.1.3.10.2.1.10.<ifIndex>.1 = 4096
```

- **net-snmp** commands

```
server > snmpset -v2c -c <community_name> <cmts_ip>
1.3.6.1.4.1.4491.2.1.27.1.3.10.2.1.10.<ifIndex>.1 u 4096
SNMPv2-SMI::enterprises.4491.2.1.27.1.3.10.2.1.10.<ifIndex>.1 = Gauge32: 4096

server > snmpget -v2c -c <community_name> <cmts_ip>
1.3.6.1.4.1.4491.2.1.27.1.3.10.2.1.10.<ifIndex>.1
SNMPv2-SMI::enterprises.4491.2.1.27.1.3.10.2.1.10.<ifIndex>.1 = Gauge32: 4096
```

- `docsPnmCmtsUtscCfgAveraging` - This attribute specifies whether the CCAP should average spectral frequency domain sample power to remove spurious spectral peaks and troughs and the number of samples to use to calculate the average power. The CCAP must not calculate the average of the upstream spectrum

samples when the value of Averaging is zero. The CCAP MUST calculate the average power of upstream spectrum samples, over the number of samples that are specified, when the value of the Averaging attribute is nonzero.

- **snmpr** commands

```

• server > setany -v2c <cmts_ip> <community_name>
  1.3.6.1.4.1.4491.2.1.27.1.3.10.2.1.11.<ifIndex>.1 -g 245
  clabProjDocsis.27.1.3.10.2.1.11.<ifIndex>.1 = 245

• server > getone -v2c <cmts_ip> <community_name>
  1.3.6.1.4.1.4491.2.1.27.1.3.10.2.1.11.<ifIndex>.1 u 245
  clabProjDocsis.27.1.3.10.2.1.11.<ifIndex>.1 = 245

```

- **net-snmp** commands

```

• server > snmpset -v2c -c <community_name> <cmts_ip>
  1.3.6.1.4.1.4491.2.1.27.1.3.10.2.1.11.<ifIndex>.1 u 245
  SNMPv2-SMI::enterprises.4491.2.1.27.1.3.10.2.1.11.<ifIndex>.1 = Gauge32: 245

• server > snmpget -v2c -c <community_name> <cmts_ip>
  1.3.6.1.4.1.4491.2.1.27.1.3.10.2.1.11.<ifIndex>.1
  SNMPv2-SMI::enterprises.4491.2.1.27.1.3.10.2.1.11.<ifIndex>.1 = Gauge32: 245

```

- docsPnmCmtsUtsCcfgCmMacAddr - This attribute specifies the cable modem from which the CCAP captures upstream transmissions. This attribute is used only when the TriggerMode is CmMac and is ignored otherwise.

- **net-snmp** commands

```

• server > snmpset -v2c -c <community_name> <cmts_ip>
  1.3.6.1.4.1.4491.2.1.27.1.3.10.2.1.6.<ifIndex>.1
  x "CM-MAC"

• server > snmpget -v2c -c <community_name> <cmts_ip>
  1.3.6.1.4.1.4491.2.1.27.1.3.10.2.1.6.<ifIndex>.1

```

- docsPnmCmtsUtsCcfgQualifyCenterFreq - This attribute specifies the center frequency of a band that is used to qualify a spectrum for upload. The average of the FFT linear power values in this band is computed and compared to a threshold. If the average power in the band is below the threshold, the spectrum is discarded. If the power average is greater than or equal to the threshold, the spectrum is considered qualified.

- **snmpr** commands

```

• server > setany -v2c <cmts_ip> <community_name>
  1.3.6.1.4.1.4491.2.1.27.1.3.10.2.1.13.<ifIndex>.1 -g 102400000
  clabProjDocsis.27.1.3.10.2.1.13.<ifIndex>.1 = 102400000

• server > getone -v2c <cmts_ip> <community_name>
  1.3.6.1.4.1.4491.2.1.27.1.3.10.2.1.13.<ifIndex>.1
  clabProjDocsis.27.1.3.10.2.1.13.<ifIndex>.1 = 102400000

```

- **net-snmp** commands

```

• server > snmpset -v2c -c <community_name> <cmts_ip>
  1.3.6.1.4.1.4491.2.1.27.1.3.10.2.1.13.<ifIndex>.1 u 102400000
  SNMPv2-SMI::enterprises.4491.2.1.27.1.3.10.2.1.13.<ifIndex>.1 = Gauge32:
  102400000

```

```

• server > snmpget -v2c -c <community_name> <cmts_ip>
1.3.6.1.4.1.4491.2.1.27.1.3.10.2.1.13.<ifIndex>.1
SNMPv2-SMI::enterprises.4491.2.1.27.1.3.10.2.1.13.<ifIndex>.1 = Gauge32:
102400000

```

- `docsPnmCmtsUtscCfgQualifyBw` - This attribute specifies the bandwidth of a band that is used to qualify a spectrum for upload. The average of the FFT linear power values in this band is computed and compared to a threshold. If the average power in the band is below the threshold, the spectrum is discarded. If the power average is greater than or equal to the threshold, the spectrum is considered qualified.

- **snmp** commands:

```

• server > setany -v2c <cmts_ip> <community_name>
1.3.6.1.4.1.4491.2.1.27.1.3.10.2.1.14.<ifIndex>.1 -g 25600000
clabProjDocsis.27.1.3.10.2.1.14.<ifIndex>.1 = 25600000

```

```

• server > getone -v2c <cmts_ip> <community_name>
1.3.6.1.4.1.4491.2.1.27.1.3.10.2.1.14.<ifIndex>.1
clabProjDocsis.27.1.3.10.2.1.14.<ifIndex>.1 = 25600000

```

- **net-snmp** commands:

```

• server > snmpset -v2c -c <community_name> <cmts_ip>
1.3.6.1.4.1.4491.2.1.27.1.3.10.2.1.14.<ifIndex>.1 u 25600000
SNMPv2-SMI::enterprises.4491.2.1.27.1.3.10.2.1.14.<ifIndex>.1 = Gauge32: 25600000

```

```

• server > snmpget -v2c -c <community_name> <cmts_ip>
1.3.6.1.4.1.4491.2.1.27.1.3.10.2.1.14.<ifIndex>.1
SNMPv2-SMI::enterprises.4491.2.1.27.1.3.10.2.1.14.<ifIndex>.1 = Gauge32: 25600000

```

- `docsPnmCmtsUtscCfgQualifyThrshld` - This attribute specifies the threshold that is applied to qualify a spectrum for upload. The average of the FFT linear power values in the specified band is computed and compared to this threshold. If the average power in the band is below the threshold, the spectrum is discarded. If the power average is greater than or equal to the threshold, the spectrum is considered qualified.

- **snmp** commands

```

• server > setany -v2c <cmts_ip> <community_name>
1.3.6.1.4.1.4491.2.1.27.1.3.10.2.1.15.<ifIndex>.1 -i 200
clabProjDocsis.27.1.3.10.2.1.15.<ifIndex> = -200

```

```

• server > getone -v2c <cmts_ip> <community_name>
1.3.6.1.4.1.4491.2.1.27.1.3.10.2.1.15.<ifIndex>.1
clabProjDocsis.27.1.3.10.2.1.15.<ifIndex>.1 = -200

```

- **net-snmp** commands

```

• server > snmpset -v2c -c <community_name> <cmts_ip>
1.3.6.1.4.1.4491.2.1.27.1.3.10.2.1.15.<ifIndex>.1 i -200
SNMPv2-SMI::enterprises.4491.2.1.27.1.3.10.2.1.15.<ifIndex>.1 = INTEGER: -200

```

```

• server > snmpget -v2c -c <community_name> <cmts_ip>
1.3.6.1.4.1.4491.2.1.27.1.3.10.2.1.15.<ifIndex>.1
SNMPv2-SMI::enterprises.4491.2.1.27.1.3.10.2.1.15.<ifIndex>.1 = INTEGER: -200

```

- `docsPnmCmtsUtscCfgWindow` - This attribute indicates which of the upstream triggered spectrum capture function window formats are supported by the CCAP. Currently Cisco cBR-8 supports rectangular

(default), Blackmann-Harris, and Hann and Hamming formats. The following are the enumerated values for window mode for PNM.

- D\_docsPnmCmtsUtscCfgWindow\_other 1
- D\_docsPnmCmtsUtscCfgWindow\_rectangular 2
- D\_docsPnmCmtsUtscCfgWindow\_hann 3
- D\_docsPnmCmtsUtscCfgWindow\_blackmanHarris 4
- D\_docsPnmCmtsUtscCfgWindow\_hamming 5
- D\_docsPnmCmtsUtscCfgWindow\_flatTop 6
- D\_docsPnmCmtsUtscCfgWindow\_gaussian 7
- D\_docsPnmCmtsUtscCfgWindow\_chebyshev 8

- Window mode set and get examples:

- **snmpr** commands:

```

server > setany -v2c <cmts_ip> <community_name>
1.3.6.1.4.1.4491.2.1.27.1.3.10.2.1.16.<ifIndex>.1 -i 3
clabProjDocsis.27.1.3.10.2.1.16.<ifIndex>.1= 3

server > getone -v2c <cmts_ip> <community_name>
1.3.6.1.4.1.4491.2.1.27.1.3.10.2.1.16.<ifIndex>.1
clabProjDocsis.27.1.3.10.2.1.16.<ifIndex>.1 = 3

server > setany -v2c <cmts_ip> <community_name>
1.3.6.1.4.1.4491.2.1.27.1.3.10.2.1.16.<ifIndex>.1 -i 6
Error code set in packet - COMMIT_FAILED_ERROR: 1.

```

- **net-snmp** commands:

```

server > snmpset -v2c -c <community_name> <cmts_ip>
1.3.6.1.4.1.4491.2.1.27.1.3.10.2.1.16.<ifIndex>.1 i 3
SNMPv2-SMI::enterprises.4491.2.1.27.1.3.10.2.1.16.<ifIndex>.1 = INTEGER: 3

server > snmpget -v2c -c <community_name> <cmts_ip>
1.3.6.1.4.1.4491.2.1.27.1.3.10.2.1.16.<ifIndex>.1
SNMPv2-SMI::enterprises.4491.2.1.27.1.3.10.2.1.16.<ifIndex>.1 = INTEGER: 3

server > snmpset -v2c -c <community_name> <cmts_ip>
1.3.6.1.4.1.4491.2.1.27.1.3.10.2.1.16.<ifIndex>.1 i 6
Error in packet.
Reason: commitFailed
Failed object: SNMPv2-SMI::enterprises.4491.2.1.27.1.3.10.2.1.16.<ifIndex>.1

```



---

**Note**

- Flat-top, Gaussian, and Chebyshev window-modes are not supported.
- 

- docsPnmCmtsUtscCfgOutputFormat - This attribute indicates the upstream triggered spectrum capture function data output formats that are supported by the CCAP. The CCAP is capable of reporting upstream spectrum sample FFT output data in power format. The enumeration value for power format is fftPower.

CCAP supports time-IQ and fftPower output format. The time-IQ is supported from Cisco IOS XE Gibraltar 16.12.1x. The following are the enumerated values for output format mode for PNM.

- D\_docsPnmCmtsUtscCfgOutputFormat\_timeIQ 1
- D\_docsPnmCmtsUtscCfgOutputFormat\_fftPower 2
- D\_docsPnmCmtsUtscCfgOutputFormat\_rawAdc 3
- D\_docsPnmCmtsUtscCfgOutputFormat\_fftIQ 4
- D\_docsPnmCmtsUtscCfgOutputFormat\_fftAmplitude 5
- D\_docsPnmCmtsUtscCfgOutputFormat\_fftDb 6

• Output format mode set and get examples:

• **snmpr** commands:

- server > setany -v2c <cmts\_ip> <community\_name>  
1.3.6.1.4.1.4491.2.1.27.1.3.10.2.1.17.<ifIndex>.1 -i 2  
clabProjDocsis.27.1.3.10.2.1.16.<ifIndex>.1 = 2
- server > getone -v2c <cmts\_ip> <community\_name>  
1.3.6.1.4.1.4491.2.1.27.1.3.10.2.1.17.<ifIndex>.1  
clabProjDocsis.27.1.3.10.2.1.17.<ifIndex>.1 = 2
- server > setany -v2c <cmts\_ip> <community\_name>  
1.3.6.1.4.1.4491.2.1.27.1.3.10.2.1.17.<ifIndex>.1 -i 4  
Error code set in packet - COMMIT\_FAILED\_ERROR: 1.

• **net-snmp** commands:

- server > snmpset -v2c -c <community\_name> <cmts\_ip>  
1.3.6.1.4.1.4491.2.1.27.1.3.10.2.1.17.<ifIndex>.1 i 2  
SNMPv2-SMI::enterprises.4491.2.1.27.1.3.10.2.1.17.<ifIndex>.1 = INTEGER: 2
- server > snmpget -v2c -c <community\_name> <cmts\_ip>  
1.3.6.1.4.1.4491.2.1.27.1.3.10.2.1.17.<ifIndex>.1  
SNMPv2-SMI::enterprises.4491.2.1.27.1.3.10.2.1.17.<ifIndex>.1 = INTEGER: 2
- server > snmpset -v2c -c <community\_name> <cmts\_ip>  
1.3.6.1.4.1.4491.2.1.27.1.3.10.2.1.17.<ifIndex>.1 i 4
- server > snmpset -v2c -c <community\_name> <cmts\_ip>  
1.3.6.1.4.1.4491.2.1.27.1.3.10.2.1.17.<ifIndex>.1 i 1



---

**Note** Only the `fft-pwr` and `time-IQ` output formats are currently supported.

---

- `docsPnmCmtsUtscCfgRepeatPeriod` - This attribute specifies the length of time in milliseconds for which the CCAP continues to capture and return FFT results when in free running mode. The CCAP is permitted to trigger at larger intervals if unable to support the requested interval. Configuring a zero value indicates that the test is to run once only.
- The Repeat Period is configured in microseconds and default is 50000 usec. The CCAP MUST reject an attempt to set RepeatPeriod to a value greater than the current value of FreeRunDuration.

- Repeat Period set and get examples:

- **snmpr** commands:

```

• server > setany -v2c <cmts_ip> <community_name>
1.3.6.1.4.1.4491.2.1.27.1.3.10.2.1.18.<ifIndex>.1 -g 25000
clabProjDocsis.27.1.3.10.2.1.18.<ifIndex>.1 = 25000

• server > getone -v2c <cmts_ip> <community_name>
1.3.6.1.4.1.4491.2.1.27.1.3.10.2.1.18.<ifIndex>.1
clabProjDocsis.27.1.3.10.2.1.18.<ifIndex>.1 = 25000

```

- **net-snmp** commands:

```

• server > snmpset -v2c -c <community_name> <cmts_ip>
1.3.6.1.4.1.4491.2.1.27.1.3.10.2.1.18.<ifIndex>.1 u 25000
SNMPv2-SMI::enterprises.4491.2.1.27.1.3.10.2.1.18.<ifIndex>.1 = Gauge32: 25000

• server > snmpget -v2c -c <community_name> <cmts_ip>
1.3.6.1.4.1.4491.2.1.27.1.3.10.2.1.18.<ifIndex>.1
SNMPv2-SMI::enterprises.4491.2.1.27.1.3.10.2.1.18.<ifIndex>.1 = Gauge32: 25000

```

- docsPnmCmtsUtsCcfgFreeRunDuration - This attribute specifies the length of time in milliseconds for which the CCAP continues to capture and return FFT results when in free running mode. Sample captures are expected to take a few microseconds. If FreeRunDuration is set for longer than a sample capture duration, the CCAP could potentially capture more sample data than it can store.
- The CCAP MUST reject an attempt to set FreeRunDuration to a value less than the current value of RepeatPeriod. Freerun duration is configured in millisecond and the default value is 1000ms (1 second). The CCAP CLC currently captures 10 samples per second stacked in a single file. With default freerun duration configuration, there will be 11 samples.
- FreeRun Duration set and get examples:

- **snmpr** commands

```

• server > setany -v2c <cmts_ip> <community_name>
1.3.6.1.4.1.4491.2.1.27.1.3.10.2.1.19.<ifIndex>.1 -g 5000
clabProjDocsis.27.1.3.10.2.1.19.<ifIndex>.1 = 5000

• server > getone -v2c <cmts_ip> <community_name>
1.3.6.1.4.1.4491.2.1.27.1.3.10.2.1.19.<ifIndex>.1
clabProjDocsis.27.1.3.10.2.1.19.<ifIndex>.1 = 5000

```

- **net-snmp** commands

```

• server > snmpset -v2c -c <community_name> <cmts_ip>
1.3.6.1.4.1.4491.2.1.27.1.3.10.2.1.19.<ifIndex>.1 u 5000
SNMPv2-SMI::enterprises.4491.2.1.27.1.3.10.2.1.19.<ifIndex>.1 = Gauge32: 5000

• server > snmpget -v2c -c <community_name> <cmts_ip>
1.3.6.1.4.1.4491.2.1.27.1.3.10.2.1.19.<ifIndex>.1
SNMPv2-SMI::enterprises.4491.2.1.27.1.3.10.2.1.19.<ifIndex>.1 = Gauge32: 5000

```

- docsPnmCmtsUtsCcfgTriggerCount - This attribute determines the number of times to trigger upstream spectrum sample capture when Enable and InitiateTest are set to true and configured trigger conditions are met. The trigger count configuration does NOT apply and is ignored by CCAP for captures in FreeRun trigger mode.

- Trigger count set and get examples:

- **snmpr** commands

```

server > setany -v2c <cmts_ip> <community_name>
1.3.6.1.4.1.4491.2.1.27.1.3.10.2.1.20.<ifIndex>.1 -g 200
clabProjDocsis.27.1.3.10.2.1.20.<ifIndex>.1 = 200

server > getone -v2c <cmts_ip> <community_name>
1.3.6.1.4.1.4491.2.1.27.1.3.10.2.1.20.<ifIndex>.1
clabProjDocsis.27.1.3.10.2.1.20.<ifIndex>.1 = 200

```

- **net-snmp** commands

```

server > snmpset -v2c -c <community_name> <cmts_ip>
1.3.6.1.4.1.4491.2.1.27.1.3.10.2.1.20.<ifIndex>.1 u 200
SNMPv2-SMI::enterprises.4491.2.1.27.1.3.10.2.1.20.<ifIndex>.1 = Gauge32: 200

server > snmpget -v2c -c <community_name> <cmts_ip>
1.3.6.1.4.1.4491.2.1.27.1.3.10.2.1.20.<ifIndex>.1
SNMPv2-SMI::enterprises.4491.2.1.27.1.3.10.2.1.20.<ifIndex>.1 = Gauge32: 200

```

- docsPnmCmtsUtscCfgStatus - This attribute determines the creation, deletion, and change of status of an actual capture configuration entry on any port of the CCAP CLC. All capture entries must first be created by a client on a port before attempting to initiate any tests on the port. Thereby the client ‘owns’ that port and its configuration after creation. No other client can run any tests on the port till the currently active client ‘destroys’ the configuration entry and thereby releases ownership of that port.
- Any tests on a given port that is owned by a client can be run only when the capture configuration status is ‘Active’. When a configuration is created, it is created with certain default values and marked ‘Not Ready’. All capture parameters must be configured in valid range for the capture entry status to become ‘Active’. If the configuration values for various capture parameters are modified by the user/client and not according to the OSSI specification, the configuration status of the entry will be marked ‘NotReady’.
- A capture configuration entry cannot be modified to any state unless created first. An entry cannot be recreated without destroying the previous version first. An entry cannot be modified when capture tests are currently running on the port.

- The following are the enumerated values for configuration entry status for PNM:

- D\_docsPnmCmtsUtscCfgStatus\_active 1
- D\_docsPnmCmtsUtscCfgStatus\_notInService 2
- D\_docsPnmCmtsUtscCfgStatus\_notReady 3
- D\_docsPnmCmtsUtscCfgStatus\_createAndGo 4
- D\_docsPnmCmtsUtscCfgStatus\_createAndWait 5
- D\_docsPnmCmtsUtscCfgStatus\_destroy 6

- Utsc Configuration Entry set/get example:

- **snmpr** commands

```

server > setany -v2c <cmts_ip> <community_name>
1.3.6.1.4.1.4491.2.1.27.1.3.10.2.1.21.<ifIndex>.1 -i 4
clabProjDocsis.27.1.3.10.2.1.21.<ifIndex>.1 = 4

```



```

• server > getone -v2c <cmts_ip> <community_name>
  1.3.6.1.4.1.4491.2.1.27.1.3.10.2.1.21.<ifIndex>.1
  clabProjDocsis.27.1.3.10.2.1.21.<ifIndex>.1 = 1

```

- **net-snmp** commands

```

• server > snmpset -v2c -c <community_name> <cmts_ip>
  1.3.6.1.4.1.4491.2.1.27.1.3.10.2.1.21.<ifIndex>.1 i 4
  SNMPv2-SMI::enterprises.4491.2.1.27.1.3.10.2.1.21.<ifIndex>.1 = INTEGER: 4

• server > snmpget -v2c -c <community_name> <cmts_ip>
  1.3.6.1.4.1.4491.2.1.27.1.3.10.2.1.21.<ifIndex>.1
  SNMPv2-SMI::enterprises.4491.2.1.27.1.3.10.2.1.21.<ifIndex>.1 = INTEGER: 3

```



---

**Note** A configuration can be created with certain default values and is marked 'Not Ready'. It is only changed to 'Active' when valid capture configuration parameters are configured by the user. Capture tests can only be run on configurations that are 'Active'.

---

- Set multiple capture config parameters at the same time.

```

• Server > setany -v2c <cmts_ip> <community_name>
  1.3.6.1.4.1.4491.2.1.27.1.3.10.2.1.18.<ifIndex>.1 -g 45000
  1.3.6.1.4.1.4491.2.1.27.1.3.10.2.1.20.<ifIndex>.1 -g 10
  1.3.6.1.4.1.4491.2.1.27.1.3.10.2.1.8.<ifIndex>.1 -g 100000000
  1.3.6.1.4.1.4491.2.1.27.1.3.10.2.1.10.<ifIndex>.1 -g 8092
  1.3.6.1.4.1.4491.2.1.27.1.3.10.2.1.15.<ifIndex>.1 -i -100
  clabProjDocsis.27.1.3.10.2.1.18.<ifIndex>.1 = 45000
  clabProjDocsis.27.1.3.10.2.1.20.<ifIndex>.1 = 10
  clabProjDocsis.27.1.3.10.2.1.8.<ifIndex>.1 = 100000000
  clabProjDocsis.27.1.3.10.2.1.10.<ifIndex>.1 = 8092
  clabProjDocsis.27.1.3.10.2.1.15.<ifIndex>.1 = -100 10.3.1.1.<ifIndex>.1 = 0

```

SNMP walk is supported for all the above MIB objects.

The following is an example of SNMP walk on upstream triggered spectrum capture configuration parameter repeat period:

```

server > snmpwalk -v2c <cmts_ip> -c <community_name> 1.3.6.1.4.1.4491.2.1.27.1.3.10.2.1.18

SNMPv2-SMI::enterprises.4491.2.1.27.1.3.10.2.1.18.<ifIndex>.1 = Gauge32: 45000
SNMPv2-SMI::enterprises.4491.2.1.27.1.3.10.2.1.18.<ifIndex>.1 = Gauge32: 45000
SNMPv2-SMI::enterprises.4491.2.1.27.1.3.10.2.1.18.<ifIndex>.1 = Gauge32: 45000
SNMPv2-SMI::enterprises.4491.2.1.27.1.3.10.2.1.18.<ifIndex>.1 = Gauge32: 45000
SNMPv2-SMI::enterprises.4491.2.1.27.1.3.10.2.1.18.<ifIndex>.1 = Gauge32: 45000
SNMPv2-SMI::enterprises.4491.2.1.27.1.3.10.2.1.18.<ifIndex>.1 = Gauge32: 45000
SNMPv2-SMI::enterprises.4491.2.1.27.1.3.10.2.1.18.<ifIndex>.1 = Gauge32: 50000
<<!--snip-->

```

## Upstream Triggered Spectrum Capture Control Objects and MIBs

The following Upstream Triggered Spectrum Capture control objects and MIBs are supported:

- PNM UTSC OBJECTS OID: 1.3.6.1.4.1.4491.2.1.27.1.3.10
- PNM UTSC CAPTURE CONTROL OID: 1.3.6.1.4.1.4491.2.1.27.1.3.10.3.1.1.Y.Z

Where Y is Ifindex, and Z is the PNM Upstream Triggered Spectrum Capture Configuration Index – Which is always 1. Currently only one capture configuration per upstream port is supported.

- The capture control entry can be used to start captures or stop any active captures. The `docsPnmCmtsUtscCtrlInitiateTest` is a boolean value which when set, initiates a capture.
- Starting a capture (You can only start a capture only if you have configured and owned the port, and if the capture configuration entry is active).

- **snmpr** commands:

```

server > setany -v2c <cmts_ip> <community_name>
1.3.6.1.4.1.4491.2.1.27.1.3.10.3.1.1.<ifIndex>.1 -i 1
clabProjDocsis.27.1.3.10.3.1.1.<ifIndex>.1 = 1

server > getone -v2c <cmts_ip> <community_name>
1.3.6.1.4.1.4491.2.1.27.1.3.10.3.1.1.<ifIndex>.1
clabProjDocsis.27.1.3.10.3.1.1.<ifIndex>.1 = 1

```

- **net-snmp** commands:

```

server > snmpset -v2c -c <community_name> <cmts_ip>
1.3.6.1.4.1.4491.2.1.27.1.3.10.3.1.1.<ifIndex>.1 i 1
SNMPv2-SMI::enterprises.4491.2.1.27.1.3.10.3.1.1.<ifIndex>.1 = INTEGER: 1

server > snmpget -v2c -c <community_name> <cmts_ip>
1.3.6.1.4.1.4491.2.1.27.1.3.10.3.1.1.<ifIndex>.1
SNMPv2-SMI::enterprises.4491.2.1.27.1.3.10.3.1.1.<ifIndex>.1 = INTEGER: 1

```

- Stop a capture (You can stop an active capture only if you own that port):

- **snmpr** commands:

```

server > setany -v2c <cmts_ip> <community_name>
1.3.6.1.4.1.4491.2.1.27.1.3.10.3.1.1.<ifIndex>.1 -i 2
clabProjDocsis.27.1.3.10.3.1.1.<ifIndex>.1 = 2

server > getone -v2c <cmts_ip> <community_name>
1.3.6.1.4.1.4491.2.1.27.1.3.10.3.1.1.<ifIndex>.1
clabProjDocsis.27.1.3.10.3.1.1.<ifIndex>.1 = 2

```



---

**Note** Ensure that you pass a value '2', for the **setany** command to stop the capture.

---

- **net-snmp** commands:

```

server > snmpset -v2c -c <community_name> <cmts_ip>
1.3.6.1.4.1.4491.2.1.27.1.3.10.3.1.1.<ifIndex>.1 i 2
SNMPv2-SMI::enterprises.4491.2.1.27.1.3.10.3.1.1.<ifIndex>.1 = INTEGER: 2

server > snmpget -v2c -c <community_name> <cmts_ip>
1.3.6.1.4.1.4491.2.1.27.1.3.10.3.1.1.<ifIndex>.1
SNMPv2-SMI::enterprises.4491.2.1.27.1.3.10.3.1.1.<ifIndex>.1 = INTEGER: 2

```



**Note** Ensure that you pass a value '2', for the **snmpset** command to stop the capture.

## Upstream Triggered Spectrum Capture Status Objects and MIBs

The following Upstream Triggered Spectrum Capture status objects and MIBs are supported:

- PNM UTSC OBJECTS OID: 1.3.6.1.4.1.4491.2.1.27.1.3.10
- PNM UTSC CAPTURE STATUS OID: 1.3.6.1.4.1.4491.2.1.27.1.3.10.4.1.1.Y.Z  
Where Y is Ifindex, and Z is the PNM Upstream Triggered Spectrum Capture Configuration Index – Which is always 1. Currently only one capture configuration per upstream port is supported.
- The capture status MIB is a read-only MIB. It reports the status of the capture on a given port (if owned by that client).
- When the value is sampleReady, the CCAP has completed capturing and recording samples. Following are the enumerated values for capture status entry for PNM.

- D\_docsPnmCmtsUtscStatusMeasStatus\_other 1
- D\_docsPnmCmtsUtscStatusMeasStatus\_inactive 2
- D\_docsPnmCmtsUtscStatusMeasStatus\_busy 3
- D\_docsPnmCmtsUtscStatusMeasStatus\_sampleReady 4
- D\_docsPnmCmtsUtscStatusMeasStatus\_error 5
- D\_docsPnmCmtsUtscStatusMeasStatus\_resourceUnavailable 6
- D\_docsPnmCmtsUtscStatusMeasStatus\_sampleTruncated 7

- The status is inactive when the capture configuration entry is created and is marked busy when the tests are actively running on the port. Any platform resource limitation to run a test to make the status 'resource unavailable' and the error encountered while running a test would mark the status as 'error'.
- Get capture status on a port (You can get the status of capture on the port only if you own that port).

- **snmpr** commands:

```
server > getone -v2c <cmts_ip> <community_name>
1.3.6.1.4.1.4491.2.1.27.1.3.10.4.1.1.<ifIndex>.1
clabProjDocsis.27.1.3.10.4.1.1.<ifIndex>.1 = 4
```

- **net-snmp** commands:

```
server > snmpget -v2c -c <community_name> <cmts_ip>
1.3.6.1.4.1.4491.2.1.27.1.3.10.4.1.1.<ifIndex>.1
SNMPv2-SMI::enterprises.4491.2.1.27.1.3.10.4.1.1.<ifIndex>.1 = INTEGER: 4
```

## Upstream Triggered Spectrum Capture Capability Objects and MIBs

The following Upstream Triggered Spectrum Capture capability objects and MIBs are supported for PNM:

- PNM UTSC OBJECTS OID: 1.3.6.1.4.1.4491.2.1.27.1.3.10
- PNM UTSC CAPTURE CAPABILITY OID: 1.3.6.1.4.1.4491.2.1.27.1.3.10.1.1.X.Y  
Where X is the capability parameter and Y is the Ifindex.
- The capture capability MIB is a read-only MIB. The Upstream Triggered Spectrum Capture Capabilities object exposes capabilities that are supported by the CCAP for Upstream Triggered Spectrum Capture trigger modes, data output formats, and windowing function used when performing the discrete Fourier transform.
- The following are the enumerated values for capture capability entry for PNM for CCAP.
  - docsPnmCmtsUtscCapabTriggerMode 1
  - docsPnmCmtsUtscCapabOutputFormat 2
  - docsPnmCmtsUtscCapabWindow 3
  - docsPnmCmtsUtscCapabDescription 4

- Get capture capability on a port:

- **snmp** commands:

- `server > getone -v2c <cmts_ip> <community_name>  
1.3.6.1.4.1.4491.2.1.27.1.3.10.1.1.1.<ifIndex>  
docsPnmCmtsObjects.10.1.1.1.<ifIndex> = 00 02`
- `server > getone -v2c <cmts_ip> <community_name>  
1.3.6.1.4.1.4491.2.1.27.1.3.10.1.1.2.<ifIndex>  
docsPnmCmtsObjects.10.1.1.2.<ifIndex> = 04`
- `server > getone -v2c <cmts_ip> <community_name>  
1.3.6.1.4.1.4491.2.1.27.1.3.10.1.1.3.<ifIndex>  
docsPnmCmtsObjects.10.1.1.3.<ifIndex> = 1e`
- `server > getone -v2c <cmts_ip> <community_name>  
1.3.6.1.4.1.4491.2.1.27.1.3.10.1.1.4.<ifIndex>  
docsPnmCmtsObjects.10.1.1.4.<ifIndex> = Center Frequency range and resolution`

- **net-snmp** commands:

- `server > snmpget -v2c -c <community_name> <cmts_ip>  
1.3.6.1.4.1.4491.2.1.27.1.3.10.1.1.1.<ifIndex>  
SNMPv2-SMI::enterprises.4491.2.1.27.1.3.10.1.1.1.<ifIndex> = Hex-STRING: 00 02`
- `server > snmpget -v2c -c <community_name> <cmts_ip>  
1.3.6.1.4.1.4491.2.1.27.1.3.10.1.1.2.<ifIndex>  
SNMPv2-SMI::enterprises.4491.2.1.27.1.3.10.1.1.2.<ifIndex> = Hex-STRING: 04`
- `server > snmpget -v2c -c <community_name> <cmts_ip>  
1.3.6.1.4.1.4491.2.1.27.1.3.10.1.1.3.<ifIndex>  
SNMPv2-SMI::enterprises.4491.2.1.27.1.3.10.1.1.3.<ifIndex> = Hex-STRING: 1`
- `server > snmpget -v2c -c <community_name> <cmts_ip>  
1.3.6.1.4.1.4491.2.1.27.1.3.10.1.1.4.<ifIndex>  
SNMPv2-SMI::enterprises.4491.2.1.27.1.3.10.1.1.4.<ifIndex> = STRING: "Center  
Frequency range and resolution"`

## Upstream Triggered Spectrum Capture Bulk Data Control Objects and MIBs

Table 151: Feature History

| Feature Name                        | Release Information         | Feature Description                                                                                                                                                                                                                                                                                       |
|-------------------------------------|-----------------------------|-----------------------------------------------------------------------------------------------------------------------------------------------------------------------------------------------------------------------------------------------------------------------------------------------------------|
| Multiple Bulk Data Transfer support | Cisco IOS XE Dublin 17.12.1 | You can now configure multiple BDTs for the following: <ul style="list-style-type: none"> <li>For TFTP in CM-MAC and Other trigger modes. PNM BDT (DocsPnmBulkDataTransferCfgTable) MIB extends support from one TFTP server address to three.</li> <li>Guestshell in IPv4 for all UTSC modes.</li> </ul> |
| PNM BDT MIB Updates                 | Cisco IOS XE Dublin 17.12.1 | In this release, PNM BDT MIB (docsPnmBulkDataTransferCfg) can support both OFDMA RxMER and UTSC. (UTSC has three trigger modes: Freerun, other, and CM-MAC.) The <b>docPnmBulkDestIpaddr</b> object (UTSC CM-MAC) is also supported.                                                                      |

The following Upstream Triggered Spectrum Capture bulk data control objects and MIBs are supported for PNM:

- PNM Bulk Data Control Objects OID: 1.3.6.1.4.1.4491.2.1.27.1.1.1
- PNM BULK DATA CONTROL OID: 1.3.6.1.4.1.4491.2.1.27.1.1.1.X

Where X is the bulk data transfer control parameter.

- The Bulk Data Transfer (BDT) control objects that are supported are the IPAddress type, BDT server IP and BDT destination path. This indicates to the CCAP the location where the capture results files are sent through TFTP transfer. In CBR8, the TFTP transfer is done through IOX container and as such, other BDT objects aren't relevant to this design model. IP address type can be automatically set by CCAP based on the server IP value specified.
- The following are the enumerated values for BDT for PNM:
  - docsPnmBulkDestIpAddrType 1
  - docsPnmBulkDestIpAddr 2
  - docsPnmBulkDestPath 3
- Set the BDT IPv4 IP address type and TFTP IP address.
  - **snmpr** commands:

```

server > setany -v2c <cmts_ip> <community_name> 1.3.6.1.4.1.4491.2.1.27.1.1.1.2.0
-o 20:01:0d:b8
docsPnmBulkDestIpAddr.0 = 20 01 0d b8

server > getone -v2c <cmts_ip> <community_name> 1.3.6.1.4.1.4491.2.1.27.1.1.1.1.0
docsPnmBulkDestIpAddrType.0 = ipv4(1)

```

```

• server > getone -v2c <cmts_ip> <community_name> 1.3.6.1.4.1.4491.2.1.27.1.1.1.2.0
docsPnmBulkDestIpAddr.0 = 20 01 0d b8

```

- **net-snmp** commands:

```

• server > snmpset -v2c -c <community_name> <cmts_ip>
1.3.6.1.4.1.4491.2.1.27.1.1.1.2.0 x 20010db8
SNMPv2-SMI::enterprises.4491.2.1.27.1.1.1.2.0 = Hex-STRING: 20 01 0D B8

• server > snmpget -v2c -c <community_name> <cmts_ip>
1.3.6.1.4.1.4491.2.1.27.1.1.1.1.0
SNMPv2-SMI::enterprises.4491.2.1.27.1.1.1.1.0 = INTEGER: 1

• server > snmpget -v2c -c <community_name> <cmts_ip>
1.3.6.1.4.1.4491.2.1.27.1.1.1.2.0
SNMPv2-SMI::enterprises.4491.2.1.27.1.1.1.2.0 = Hex-STRING: 20 01 0D B8

```

- Set the BDT IPv6 IP address type and TFTP IP address.

- **snmpr** commands:

```

• server > setany -v2c <cmts_ip> <community_name> 1.3.6.1.4.1.4491.2.1.27.1.1.1.2.0
-o 20:01:0d:b8:85:a3:00:00:00:00:8a:2e:03:70:73:11

docsPnmBulkDestIpAddr.0 = 2001 0db8 85a3 0000 0000 8a2e 0370 7311

• server > getone -v2c <cmts_ip> <community_name> 1.3.6.1.4.1.4491.2.1.27.1.1.1.1.0
docsPnmBulkDestIpAddrType.0 = ipv6(2)

• server > getone -v2c <cmts_ip> <community_name> 1.3.6.1.4.1.4491.2.1.27.1.1.1.2.0
docsPnmBulkDestIpAddr.0 = 2001 0db8 85a3 0000 0000 8a2e 0370 7311

```

- **net-snmp** commands:

```

• server > snmpset -v2c -c <community_name> <cmts_ip>
1.3.6.1.4.1.4491.2.1.27.1.1.1.2.0 x 20010db885a3000000008a2e03707311
SNMPv2-SMI::enterprises.4491.2.1.27.1.1.1.2.0 = Hex-STRING: 20 01 0D B8 85 A3
00 00 00 00 8A 2E 03 70 73 11

server > snmpget -v2c -c <community_name> <cmts_ip>
1.3.6.1.4.1.4491.2.1.27.1.1.1.1.0
SNMPv2-SMI::enterprises.4491.2.1.27.1.1.1.1.0 = INTEGER: 2

• server > snmpget -v2c -c <community_name> <cmts_ip>
1.3.6.1.4.1.4491.2.1.27.1.1.1.2.0
SNMPv2-SMI::enterprises.4491.2.1.27.1.1.1.2.0 = Hex-STRING: 20 01 0D B8 85 A3
00 00 00 00 8A 2E 03 70 73 11

```

- Set the BDT destination TFTP path.

- **snmpr** commands:

```

• server > setany -v2c <cmts_ip> <community_name> 1.3.6.1.4.1.4491.2.1.27.1.1.1.3.0
-o pnm
docsPnmBulkDestPath.0 = pnm

• server > getone -v2c <cmts_ip> <community_name> 1.3.6.1.4.1.4491.2.1.27.1.1.1.3.0
docsPnmBulkDestPath.0 = pnm

```

- **net-snmp** commands:

```

• server > snmpset -v2c -c <community_name> <cmts_ip>
1.3.6.1.4.1.4491.2.1.27.1.1.1.3.0 s 'pnm/test'
SSNMPv2-SMI::enterprises.4491.2.1.27.1.1.1.3.0 = STRING: "pnm/test"

• server > snmpget -v2c -c <community_name> <cmts_ip>
1.3.6.1.4.1.4491.2.1.27.1.1.1.3.0
SNMPv2-SMI::enterprises.4491.2.1.27.1.1.1.3.0 = STRING: "pnm/test"

```

### Multiple TFTP Servers Support for PNM BDT SNMP Infra

In releases before Cisco IOS XE Cupertino 17.9.1y, only one BDT TFTP destination server per CCAP is supported to store the captured UTSC or RxMER data, and maximum eight captures on upstream ports per line card and a maximum of 20 captures per CBR8 is supported for both I-CMTS and RPHY. All captured files are stored into the same TFTP server.

- Starting with Cisco IOS XE Cupertino 17.9.1y, the new PNM BDT MIB (docsPnmBulkDataTransferCfgTable) support has been added. It introduces support for multiple TFTP destination servers, and simultaneous capture of both UTSC freerun and RxMER data and store into different TFTP server locations. PNM captured files can be stored in three different TFTP servers simultaneously. Each TFTP server detail is stored into BDT table using unique index values (that is, 1, 2 and 3).
- Starting with Cisco IOS XE Dublin 17.12.1, PNM Bulk Data Transfer configuration (docsPnmBulkDataTransferCfgTable) MIB extends support from one TFTP server address to three.
- The existing PNM Bulk Data Control Table MIB remains supported with the following changes.
  - Capture doesn't start if the destination TFTP IP address and PATH aren't configured.
  - For UTSC other mode, the path isn't required and only IP is required.
- Starting with Cisco IOS XE Cupertino 17.9.1y, PNM BulkData Transfer Cfg MIB and the legacy PNM Bulk Data Control MIB, can be configured and used at the same time.
- Starting with Cisco IOS XE Cupertino 17.9.1y, we support legacy BDT table for UTSC other and CM MAC trigger modes. PNM BDT MIB (docsPnmBulkDataTransferCfgTable) can support OFDMA RxMER and UTSC.
- Starting with Cisco IOS XE Dublin 17.12.1, PNM BDT MIB (docsPnmBulkDataTransferCfg) can support both OFDMA RxMER and UTSC. UTSC has three trigger modes: Freerun, other, and CM-MAC). The **docPnmBulkDestIpaddr** object (UTSC CM-MAC) is also supported.

The captured UTSC or RxMER data are stored into the same TFTP server or different TFTP servers. This is done based on the destination index mappings between BDT table and RxMER or UTSC configuration settings. The destination index is configured as part of the docsPnmCmtsUtscCfgTable for UTSC and docsPnmCmtsUsOfdmaRxMerTable for Rxmer captures and should map to one of the indices created in the BDT table - docsPnmBulkDataTransferCfgTable. So based on this destination index mapping, captured data is stored into respective TFTP server locations.

LCs can run captures as long the max limit per LC and per cBR-8 aren't exceeded but only using one of the three allowed TFTP servers. That is, there's no restriction that a server can be mapped to only one utsc capture config at a time, the same server can be mapped to different type of captures

A BDT table entry may be modified at any given time. However, if there's a capture running using the BDT entry, the capture continues to run with the prior TFTP information with which it was started. The updated BDT details take effect only for new captures which started after that update.

### Proactive Network Management

- Provides measurement and reporting of network conditions.
- Detection of plant impairments and interference.

### docPnmBulkDestIpaddr



**Note** The **docPnmBulkDestIpaddr** object (UTSC CM-MAC) is also supported on legacy BDT table.

The **docPnmBulkDestIpaddr** object exports spectrum capture data by TFTP. The set of **docPnmBulkDestIpaddr** isn't a required configuration for initialing capture, but needed for the TFTP. In the R-PHY system, the upstream spectrum is captured by the RPD. The captured spectrum data is delivered from the RPD to the CCAP Core via SpecMan or PNM pseudowires, described in [R-UEPI]. Configure L2TPv3 pseudo wire destining to Viavi server, RPD sends the data to RCI server directly. The existing **docPnmBulkDestIpaddr** is used configure the L2TP pseudo wire destination. In a case where upstream spectrum data must be captured continuously and delivered timely to a PNM server, it's possible for the controlling CCAP Core to create a static pseudowire between the RPD and the PNM server, thus bypassing the CCAP itself in the data plane. In this case, the PNM server is considered a Traffic Engine that supports L2TPv3 data plane only but doesn't support the GCP or the L2TPv3 control plane protocols. There could be a separate communication path between the PNM server and the CCAP Core to exchange UTSC configuration, control, and status information.

## Basic Infrastructure to Support Multiple TFTP Servers

### PNM CCAP Bulk File Transfer Objects

The following are the DataTransferCfg MIB objects that are specified in DOCS-PNM-MIB in CM-SP-CCAP-OSSIV3.1-I23-220216 spec and these MIB objects is used to support multiple TFTP destination servers to upload the captured UTSC and RxMER data from cBR-8.

Starting with Cisco IOS XE 17.12.1, docsPnmBulkDataTransferCfgEntry MIB supports PNM CM-MAC, Other, and FreeRun trigger-modes for multiple destination indices.

**Table 152: PNM CCAP Bulk File Transfer Objects**

| CCAP bulk data control Objects               | OID                                 | Supported |
|----------------------------------------------|-------------------------------------|-----------|
| docsPnmBulkFileTransfer                      | 1.3.6.1.4.1.4491.2.1.27.1.1.3       | Yes       |
| docsPnmBulkDataTransferCfgTable              | 1.3.6.1.4.1.4491.2.1.27.1.1.3.1     | Yes       |
| docsPnmBulkDataTransferCfgEntry              | 1.3.6.1.4.1.4491.2.1.27.1.1.3.1.1   | Yes       |
| docsPnmBulkDataTransferCfgDestIndex          | 1.3.6.1.4.1.4491.2.1.27.1.1.3.1.1.1 | Yes       |
| docsPnmBulkDataTransferCfgDestHostname       | 1.3.6.1.4.1.4491.2.1.27.1.1.3.1.1.2 | No        |
| docsPnmBulkDataTransferCfgDestHostIpAddrType | 1.3.6.1.4.1.4491.2.1.27.1.1.3.1.1.3 | Yes       |



| CCAP bulk data control Objects              | OID                                 | Supported |
|---------------------------------------------|-------------------------------------|-----------|
| docsPnmBulkDataTransferCfgDestHostIpAddress | 1.3.6.1.4.1.4491.2.1.27.1.1.3.1.1.4 | Yes       |
| docsPnmBulkDataTransferCfgDestPort          | 1.3.6.1.4.1.4491.2.1.27.1.1.3.1.1.5 | No        |
| docsPnmBulkDataTransferCfgDestBaseUri       | 1.3.6.1.4.1.4491.2.1.27.1.1.3.1.1.6 | Yes       |
| docsPnmBulkDataTransferCfgProtocol          | 1.3.6.1.4.1.4491.2.1.27.1.1.3.1.1.7 | No        |
| docsPnmBulkDataTransferCfgLocalStore        | 1.3.6.1.4.1.4491.2.1.27.1.1.3.1.1.8 | No        |
| docsPnmBulkDataTransferCfgRowStatus         | 1.3.6.1.4.1.4491.2.1.27.1.1.3.1.1.9 | Yes       |

The destination port and protocol are set to default values which are shown below, it only has read access.

- docsPnmBulkDataTransferCfgDestPort = 69 (UDP)
- docsPnmBulkDataTransferCfgProtocol = 1 (tftp)

### UTSC Config Table Object

The new objects below are added to the existing UTSC Capture config table as mentioned in the spec but the object which is relevant to `DataTransferCfg` is supported as shown in the following table.

**Table 153: UTSC Config Table Object**

| UTSC docsPnmCmtsUtscCfgTable Objects | OID                                   | Supported |
|--------------------------------------|---------------------------------------|-----------|
| docsPnmCmtsUtscCfg                   | 1.3.6.1.4.1.4491.2.1.27.1.3.10.2.1.22 | No        |
| docsPnmCmtsUtscCfgMaxResultsPerFile  | 1.3.6.1.4.1.4491.2.1.27.1.3.10.2.1.23 | No        |
| docsPnmCmtsUtscCfgDestinationIndex   | 1.3.6.1.4.1.4491.2.1.27.1.3.10.2.1.24 | Yes       |

### Upstream OFDMA RxMER table object

The following new object is added to the existing Upstream OFDMA RxMER table:

**Table 154: Upstream OFDMA RxMER table object**

| docsPnmCmtsUsOfdmaRxMerTable object     | OID                               | Supported |
|-----------------------------------------|-----------------------------------|-----------|
| docsPnmCmtsUsOfdmaRxMerDestinationIndex | 1.3.6.1.4.1.4491.2.1.27.1.3.7.1.7 | Yes       |
| docsPnmBulkDataTransferCfgEntry         | 1.3.6.1.4.1.4491.2.1.27.1.1.3.1.1 | Yes       |

Starting with Cisco IOS XE Dublin 17.12.1, docsPnmBulkDataTransferCfgEntry MIB supports multiple destination indexes for OFDMA RxMER.

### Legacy PNM Bulk Data Control Objects

The legacy docsPnmBulkCtl objects continue to be supported for all capture types with a Guest shell design.

Table 155: Legacy PNM Bulk Data Control Objects

| docsPnmCmtsUsOfdmaRxMerTable object | OID                             |
|-------------------------------------|---------------------------------|
| docsPnmBulkDestIpAddrType           | 1.3.6.1.4.1.4491.2.1.27.1.1.1.1 |
| docsPnmBulkDestIpAddr               | 1.3.6.1.4.1.4491.2.1.27.1.1.1.2 |
| docsPnmBulkDestPath                 | 1.3.6.1.4.1.4491.2.1.27.1.1.1.3 |
| docsPnmBulkUploadControl            | 1.3.6.1.4.1.4491.2.1.27.1.1.1.4 |

The IP type and upload control are set to default values as shown below, it only has read access.

- docsPnmBulkDestIpAddrType is automatically set as the IPV4 (1)/IPV6(2), will be set automatically while configuring ipv4 or ipv6 address.
- docsPnmBulkUploadControl is set to default as autoupload (3).



**Note** This object only has read-access. You cannot modify the value via the `snmpset` command.

UTSC/RxMER capture is blocked to start capture if Destination IP address and PATH aren't configured.



**Note** The CM-MAC or OTHER mode capture types aren't supported with docsPnmBulkDataTransferCfg MIB.

### PNM UTSC/RxMER Config Destination Index

The BDT and UTSC/RxMER configs are linked using below destination the docsPnmCmtsUtscCfgDestinationIndex and docsPnmCmtsUsOfdmaRxMerDestinationIndex indices with the default index values as **0xFFFFFFFF**.

You must configure this index to one of the valid BDT config indexes. If capture is started with default index value, then it uses TFTP server details configured using Legacy MIBs. If valid BDT index is mapped, then it uses the TFTP server details that are configured in that BDT index. Capture can't be started if the row status of the mapped BDT index isn't in ACTIVE state.

### PNM BDT MIB Details

```
docsPnmBulkDataTransferCfgTable DocsPnmBulkDataTransferCfgEntry.[DestIndex]
```

BDT MIB table rows are created with unique dest index value to store three different TFTP server details. A maximum of 3 **DestIndex** are supported and the **DestIndex** values for can be 1,2, or 3. In cBR-8, the following BDT objects are supported.

Starting with Cisco IOS XE Dublin 17.12.1, docsPnmBulkDataTransferCfgEntry MIB supports multiple destination indexes.

Table 156: PNM BDT MIB Details

| OBJECTS                                      | Supported |
|----------------------------------------------|-----------|
| docsPnmBulkDataTransferCfgDestHostname       | NO        |
| docsPnmBulkDataTransferCfgDestHostIpAddrType | YES       |
| docsPnmBulkDataTransferCfgDestHostIpAddress  | YES       |
| docsPnmBulkDataTransferCfgDestPort           | NO        |
| docsPnmBulkDataTransferCfgDestBaseUri        | YES       |
| docsPnmBulkDataTransferCfgProtocol           | NO        |
| docsPnmBulkDataTransferCfgLocalStore         | NO        |
| docsPnmBulkDataTransferCfgRowStatus          | YES       |



**Note** BDT table active status is not required for OTHER mode, only a valid IP configuration is necessary. If the same BDT entry is to be used for both OTHER and freerun/rxmer mode, then the TFTP path must be specified in the correct format, in the BDT table and BDT entry must be active for freerrun/rxmer, to use this BDT entry.

- docsPnmBulkDataTransferCfgDestHostIpAddrType: To set IP types either IPV4 (1) and IPV6 (2)
- docsPnmBulkDataTransferCfgDestHostIpAddress: To set IPV4/IPV6 address in hex value. Configure BDT URI in this format - `tftp://{tftp_ip}/{tftp_path}`.
- docsPnmBulkDataTransferCfgDestBaseUri: To set IPV4/IPV6 address and PATH details in TFTP URL format.
- docsPnmBulkDataTransferCfgRowStatus: To create or update or delete a row in BDT table.
- docsPnmBulkDataTransferCfgProtocol: This object is hardcoded, same for port and supported for read.

Rows can be created with **createandgo** and **createandwait**.

If created with “**createandgo** then one time mandatory configs (ip address and Uri) are configured, and then row is moved to ACTIVE state automatically, else it remains in NOT\_READY state.

If created with **createandwait** then one time mandatory configs (ip address and Uri) are configured, and then row is moved to NotInUse state and user must configure the row to ACTIVE state manually.

### SUPHA, LCHA, and LCPR

**SUPHA** - All BDT MIB configs get erased on SUPSO, you must reconfigure the BDT rows with all required details.

**LCHA/LCPR** - BDT MIB runs in SUP IOSd process so BDT configs remain intact after LCHA/LCPR.

The following is an example of the steps that are required for PNM BDT configuration.

#### 1. Row: Create a BDT entry.

```
snmpset -v2c -c pnm 113.113.113.113 1.3.6.1.4.1.4491.2.1.27.1.1.3.1.1.9.1 i 4
```

**2. IP Type:** Set an IP type.

```
snmpset -v2c -c pnm 113.113.113.113 1.3.6.1.4.1.4491.2.1.27.1.1.3.1.1.3.1 i 1
```

**3. IP/IPv6 address:** Set IPV4/IPV6 address.

```
snmpset -v2c -c pnm 113.113.113.113 1.3.6.1.4.1.4491.2.1.27.1.1.3.1.1.4.1 x COA8648C
```

**4. Uri:** Set TFTP URL format.

```
snmpset -v2c -c pnm 113.113.113.113 1.3.6.1.4.1.4491.2.1.27.1.1.3.1.1.6.1 s
tftp://192.168.100.140/pnm1
```



---

**Note** You must configure both TFTP IP and BDT URI to initiate the UTSC capture.

---

```
RPHY#test cable pnm bdt config get-ip
```

```
BDT TABLE ip addresses:
The destination index : 1
The assigned IP is type : 1
IPv4: 192.168.100.140
IPv6: ---
```

```
BDT V0 TFTP details:
The assigned IP is type: 0
IPv4: ---
IPv6: ---
```

```
CHN3-RACK3-RPHY#test cable pnm bdt config get-path
BDT TABLE TFTP path:
```

```
Destination Index = 1 : TFTP path is = tftp://192.168.100.140/pnm1
```

```
BDT V0 TFTP Path:
```

```
oob-auto@oob-auto:/tftpboot/pnm1$ snmpwalk -v2c -c pnm 113.113.113.113
1.3.6.1.4.1.4491.2.1.27.1.1.3.1.1
iso.3.6.1.4.1.4491.2.1.27.1.1.3.1.1.2.1 = ""
iso.3.6.1.4.1.4491.2.1.27.1.1.3.1.1.3.1 = INTEGER: 1
iso.3.6.1.4.1.4491.2.1.27.1.1.3.1.1.4.1 = Hex-STRING: C0 A8 64 8C
iso.3.6.1.4.1.4491.2.1.27.1.1.3.1.1.5.1 = Gauge32: 69
iso.3.6.1.4.1.4491.2.1.27.1.1.3.1.1.6.1 = STRING: "tftp://192.168.100.140/pnm1"
iso.3.6.1.4.1.4491.2.1.27.1.1.3.1.1.7.1 = INTEGER: 1
iso.3.6.1.4.1.4491.2.1.27.1.1.3.1.1.8.1 = INTEGER: 0
iso.3.6.1.4.1.4491.2.1.27.1.1.3.1.1.9.1 = INTEGER: 1
oob-auto@oob-auto:/tftpboot/pnm1$
```

**To Delete a row:**

```
snmpset -v2c -c pnm 113.113.113.113 1.3.6.1.4.1.4491.2.1.27.1.1.3.1.1.9.1 i 6
```

```
PHY#test cable pnm bdt config get-ip
```

```
BDT TABLE ip addresses:
```

```
BDT V0 TFTP details:
```

```
The assigned IP is type: 0
IPv4: ---
IPv6: ---
```

```
RPHY#test cable pnm bdt config get-path
```

```
BDT TABLE TFTP path:
```

```
BDT V0 TFTP Path:
```

RPHY#

The following example shows PNM BDT dest index mapping to UTSC configs.

1. UTSC destination index should be set to BDT index before starting the capture. If destination index is not set in UTSC (DocsPnmCmtsUtsCcfgEntry), it uses the legacy PNM Bulk Data objects for getting the TFTP details.
2. RxMER destination index should be set to BDT index before starting the capture. If not set it uses the legacy TFTP infra. If destination index is not set in RxMER table (DocsPnmCmtsUsOfdmaRxMerEntry), it uses the legacy PNM Bulk Data objects for TFTP purpose.

Before setting BDT index:

```
RPHY#test cable pnm uts configure show 0 client-id 1 2/0/0
```

```
Acquire capcfg for capture entry success, ret: No error
```

```
Capture Config params for client 1 on clc 2/0/0
```

```
utsc config index      1
BDT TFTP dest index   FFFFFFFF
physical channel      0
logical channel       0
snmp ifIndex          490350
trigger-mode          freerun
frequency              70000000
span                   30000000
bins                   4096
window mode           blackman-harris
output format          fft-pwr
repeat-period          50000
duration               500000
trigger-count         0
capcfg entry status   active
minislot count        0
sid                    0
timestamp              0
cm-mac                 0000.0000.0000
averaging              0
qualify frequency     0
qualify bandwidth     5120000
qualify threshold     -100
```

RPHY#

```
snmpset -v2c -c pnm 113.113.113.113 1.3.6.1.4.1.4491.2.1.27.1.3.10.2.1.24.490446.1 u 1
```

```
RPHY#test cable pnm uts configure show 0 client-id 1 2/0/0
```

```
Acquire capcfg for capture entry success, ret: No error
```

```
Capture Config params for client 1 on clc 2/0/0
```

```
utsc config index      1
BDT TFTP dest index    1
physical channel      0
logical channel       0
snmp ifIndex          490350
trigger-mode          freerun
frequency              70000000
span                   30000000
bins                   4096
window mode           blackman-harris
output format          fft-pwr
repeat-period          50000
```

```

duration          500000
trigger-count     0
capcfg entry status active
minislot count    0
sid              0
timestamp        0
cm-mac           0000.0000.0000
averaging         0
qualify frequency 0
qualify bandwidth 5120000
qualify threshold -100

```

RPHY#

Before setting BDT index:

RPHY#test cable pnm rxmer show-job-list

| Job | Client | ifIndex | CM-Mac         | Status   | Enable | Pre-Eq | Num-Avgs | Retry |
|-----|--------|---------|----------------|----------|--------|--------|----------|-------|
| 0   | SNMP   | 490350  | 9058.515c.a3e8 | INACTIVE | N      | N      | 1        | 0     |

-----  
 BdtDestIndex  
 FFFFFFFF

PNM RxMER job count 1

RPHY#

After setting BDT index:

```
snmpset -v2c -c pnm 113.113.113.113 1.3.6.1.4.1.4491.2.1.27.1.3.7.1.7.490350 u 1
```

RPHY#test cable pnm rxmer show-job-list

| Job | Client | ifIndex | CM-Mac         | Status   | Enable | Pre-Eq | Num-Avgs | Retry |
|-----|--------|---------|----------------|----------|--------|--------|----------|-------|
| 0   | SNMP   | 490350  | 9058.515c.a3e8 | INACTIVE | N      | N      | 1        | 0     |

-----

PNM RxMER job count 1

RPHY#

Successful creation for three rows:

```

oob-auto@oob-auto:/tftpboot/pnm1$
oob-auto@oob-auto:/tftpboot/pnm1$ snmpset -v2c -c pnm 113.113.113.113
1.3.6.1.4.1.4491.2.1.27.1.1.3.1.1.9.1 i 4
iso.3.6.1.4.1.4491.2.1.27.1.1.3.1.1.9.1 = INTEGER: 4
oob-auto@oob-auto:/tftpboot/pnm1$ snmpset -v2c -c pnm 113.113.113.113
1.3.6.1.4.1.4491.2.1.27.1.1.3.1.1.3.1 i 1
iso.3.6.1.4.1.4491.2.1.27.1.1.3.1.1.3.1 = INTEGER: 1
oob-auto@oob-auto:/tftpboot/pnm1$ snmpset -v2c -c pnm 113.113.113.113
1.3.6.1.4.1.4491.2.1.27.1.1.3.1.1.4.1 x C0A8648C
iso.3.6.1.4.1.4491.2.1.27.1.1.3.1.1.4.1 = Hex-STRING: C0 A8 64 8C
oob-auto@oob-auto:/tftpboot/pnm1$ snmpset -v2c -c pnm 113.113.113.113
1.3.6.1.4.1.4491.2.1.27.1.1.3.1.1.6.1 s tftp://192.168.100.140/pnm1
iso.3.6.1.4.1.4491.2.1.27.1.1.3.1.1.6.1 = STRING: "tftp://192.168.100.140/pnm1"
oob-auto@oob-auto:/tftpboot/pnm1$
oob-auto@oob-auto:/tftpboot/pnm1$ snmpset -v2c -c pnm 113.113.113.113
1.3.6.1.4.1.4491.2.1.27.1.1.3.1.1.9.2 i 4
iso.3.6.1.4.1.4491.2.1.27.1.1.3.1.1.9.2 = INTEGER: 4
oob-auto@oob-auto:/tftpboot/pnm1$ snmpset -v2c -c pnm 113.113.113.113
1.3.6.1.4.1.4491.2.1.27.1.1.3.1.1.3.2 i 1
iso.3.6.1.4.1.4491.2.1.27.1.1.3.1.1.3.2 = INTEGER: 1
oob-auto@oob-auto:/tftpboot/pnm1$ snmpset -v2c -c pnm 113.113.113.113
1.3.6.1.4.1.4491.2.1.27.1.1.3.1.1.4.2 x C0A8648D
iso.3.6.1.4.1.4491.2.1.27.1.1.3.1.1.4.2 = Hex-STRING: C0 A8 64 8D

```

```

oob-auto@oob-auto:/tftpboot/pnml$ snmpset -v2c -c pnm 113.113.113.113
1.3.6.1.4.1.4491.2.1.27.1.1.3.1.1.6.2 s tftp://192.168.100.141/pnm2
iso.3.6.1.4.1.4491.2.1.27.1.1.3.1.1.6.2 = STRING: "tftp://192.168.100.141/pnm2"
oob-auto@oob-auto:/tftpboot/pnml$
oob-auto@oob-auto:/tftpboot/pnml$ snmpset -v2c -c pnm 113.113.113.113
1.3.6.1.4.1.4491.2.1.27.1.1.3.1.1.9.3 i 4
iso.3.6.1.4.1.4491.2.1.27.1.1.3.1.1.9.3 = INTEGER: 4
oob-auto@oob-auto:/tftpboot/pnml$ snmpset -v2c -c pnm 113.113.113.113
1.3.6.1.4.1.4491.2.1.27.1.1.3.1.1.3.3 i 1
iso.3.6.1.4.1.4491.2.1.27.1.1.3.1.1.3.3 = INTEGER: 1
oob-auto@oob-auto:/tftpboot/pnml$ snmpset -v2c -c pnm 113.113.113.113
1.3.6.1.4.1.4491.2.1.27.1.1.3.1.1.4.3 x COA8648E
iso.3.6.1.4.1.4491.2.1.27.1.1.3.1.1.4.3 = Hex-STRING: C0 A8 64 8E
oob-auto@oob-auto:/tftpboot/pnml$
oob-auto@oob-auto:/tftpboot/pnml$ snmpset -v2c -c pnm 113.113.113.113
1.3.6.1.4.1.4491.2.1.27.1.1.3.1.1.6.3 s tftp://192.168.100.142/pnm3
iso.3.6.1.4.1.4491.2.1.27.1.1.3.1.1.6.3 = STRING: "tftp://192.168.100.142/pnm3"
oob-auto@oob-auto:/tftpboot/pnml$

```

### Snmpwalk of three BDT rows

```

oob-auto@oob-auto:/tftpboot/pnml$ snmpwalk -v2c -c pnm 113.113.113.113
1.3.6.1.4.1.4491.2.1.27.1.1.3.1.1
iso.3.6.1.4.1.4491.2.1.27.1.1.3.1.1.2.1 = ""
iso.3.6.1.4.1.4491.2.1.27.1.1.3.1.1.2.2 = ""
iso.3.6.1.4.1.4491.2.1.27.1.1.3.1.1.2.3 = ""
iso.3.6.1.4.1.4491.2.1.27.1.1.3.1.1.3.1 = INTEGER: 1
iso.3.6.1.4.1.4491.2.1.27.1.1.3.1.1.3.2 = INTEGER: 1
iso.3.6.1.4.1.4491.2.1.27.1.1.3.1.1.3.3 = INTEGER: 1
iso.3.6.1.4.1.4491.2.1.27.1.1.3.1.1.4.1 = Hex-STRING: C0 A8 64 8C
iso.3.6.1.4.1.4491.2.1.27.1.1.3.1.1.4.2 = Hex-STRING: C0 A8 64 8D
iso.3.6.1.4.1.4491.2.1.27.1.1.3.1.1.4.3 = Hex-STRING: C0 A8 64 8E
iso.3.6.1.4.1.4491.2.1.27.1.1.3.1.1.5.1 = Gauge32: 69
iso.3.6.1.4.1.4491.2.1.27.1.1.3.1.1.5.2 = Gauge32: 69
iso.3.6.1.4.1.4491.2.1.27.1.1.3.1.1.5.3 = Gauge32: 69
iso.3.6.1.4.1.4491.2.1.27.1.1.3.1.1.6.1 = STRING: "tftp://192.168.100.140/pnm1"
iso.3.6.1.4.1.4491.2.1.27.1.1.3.1.1.6.2 = STRING: "tftp://192.168.100.141/pnm2"
iso.3.6.1.4.1.4491.2.1.27.1.1.3.1.1.6.3 = STRING: "tftp://192.168.100.142/pnm3"
iso.3.6.1.4.1.4491.2.1.27.1.1.3.1.1.7.1 = INTEGER: 1
iso.3.6.1.4.1.4491.2.1.27.1.1.3.1.1.7.2 = INTEGER: 1
iso.3.6.1.4.1.4491.2.1.27.1.1.3.1.1.7.3 = INTEGER: 1
iso.3.6.1.4.1.4491.2.1.27.1.1.3.1.1.8.1 = INTEGER: 0
iso.3.6.1.4.1.4491.2.1.27.1.1.3.1.1.8.2 = INTEGER: 0
iso.3.6.1.4.1.4491.2.1.27.1.1.3.1.1.8.3 = INTEGER: 0
iso.3.6.1.4.1.4491.2.1.27.1.1.3.1.1.9.1 = INTEGER: 1
iso.3.6.1.4.1.4491.2.1.27.1.1.3.1.1.9.2 = INTEGER: 1
iso.3.6.1.4.1.4491.2.1.27.1.1.3.1.1.9.3 = INTEGER: 1

```

### Legacy PNM MIB configuration and snmpwalk:

```

oob-auto@oob-auto:/tftpboot/pnml$ snmpset -v2c -c pnm 113.113.113.113
1.3.6.1.4.1.4491.2.1.27.1.1.1.2.0 x COA8648C
iso.3.6.1.4.1.4491.2.1.27.1.1.1.2.0 = Hex-STRING: C0 A8 64 8C
oob-auto@oob-auto:/tftpboot/pnml$ snmpset -v2c -c pnm 113.113.113.113
1.3.6.1.4.1.4491.2.1.27.1.1.1.3.0 s pnml
iso.3.6.1.4.1.4491.2.1.27.1.1.1.3.0 = STRING: "pnml"
oob-auto@oob-auto:/tftpboot/pnml$
oob-auto@oob-auto:/tftpboot/pnml$ snmpwalk -v2c -c pnm 113.113.113.113
1.3.6.1.4.1.4491.2.1.27.1.1.1
iso.3.6.1.4.1.4491.2.1.27.1.1.1.1.0 = INTEGER: 1
iso.3.6.1.4.1.4491.2.1.27.1.1.1.2.0 = Hex-STRING: C0 A8 64 8C
iso.3.6.1.4.1.4491.2.1.27.1.1.1.3.0 = STRING: "pnml"
iso.3.6.1.4.1.4491.2.1.27.1.1.1.4.0 = INTEGER: 3
oob-auto@oob-auto:/tftpboot/pnml$
oob-auto@oob-auto:/tftpboot/pnml$

```

## Bulk Data Transfer for CM-MAC Trigger Mode

The CM-MAC trigger mode now supports multiple bulkDataTransferCfg MIB, with index starting from 1 to 3. Each index denotes a target server.

The following is an example of the steps that are required for PNM BDT configuration docsPnmBulkFileTransfer MIB in CM-MAC trigger mode:

1. Set the TFTP server IP address with docsPnmBulkFileTransfer MIB with index 1.

- a. **Row:** Create a BDT entry.

```
snmpset -v2c -c private x.x.x.x 1.3.6.1.4.1.4491.2.1.27.1.1.3.1.1.9.1 i 4
```

- b. **Destination IP Type:** Set a Destination IP type.

```
snmpset -v2c -c private x.x.x.x 1.3.6.1.4.1.4491.2.1.27.1.1.3.1.1.3.1 i 1
```

- c. **Destination IP address:** Set the destination IP address.

```
snmpset -v2c -c private x.x.x.x 1.3.6.1.4.1.4491.2.1.27.1.1.3.1.1.4.1 x "14 01 00 21"
```

- d. **Uri:** Set TFTP URL format.

```
snmpset -v2c -c private x.x.x.x 1.3.6.1.4.1.4491.2.1.27.1.1.3.1.1.6.1 s
tftp://20.1.0.33/jiexiao/PNM
```

The following configuration is an example with index 2 for CM-MAC trigger mode:

```
snmpset -v2c -c private x.x.x.x 1.3.6.1.4.1.4491.2.1.27.1.1.3.1.1.9.2 i 4
snmpset -v2c -c private x.x.x.x 1.3.6.1.4.1.4491.2.1.27.1.1.3.1.1.3.2 i 1
snmpset -v2c -c private x.x.x.x 1.3.6.1.4.1.4491.2.1.27.1.1.3.1.1.4.2 x "0a 4f c4 8f"
snmpset -v2c -c private x.x.x.x 1.3.6.1.4.1.4491.2.1.27.1.1.3.1.1.6.2 s
tftp://10.79.196.143/PNM
```

The following configuration is an example with index 3 for CM-MAC trigger mode:

```
snmpset -v2c -c private x.x.x.x 1.3.6.1.4.1.4491.2.1.27.1.1.3.1.1.9.3 i 4
snmpset -v2c -c private x.x.x.x 1.3.6.1.4.1.4491.2.1.27.1.1.3.1.1.3.3 i 1
snmpset -v2c -c private x.x.x.x 1.3.6.1.4.1.4491.2.1.27.1.1.3.1.1.4.3 x "14 01 00 22"
snmpset -v2c -c private x.x.x.x 1.3.6.1.4.1.4491.2.1.27.1.1.3.1.1.6.3 s
tftp://20.1.0.34/jiexiao/WBFFT
```

2. Configure the SNMP RPD usport ifindex:

```
snmpwalk -c private -v2c 20.5.30.11 ifDescr | grep RPD| grep badb.ad13.4cf2 | grep
```

where, badb,ad13.4cf2 is the target RPD's MAC address.

You can verify the SNMP configuration using the following show command:

```
Router#show snmp mib ifmib ifindex | s 1004.9fb1.0500
RPD(1004.9fb1.0500)-usport0: Ifindex = 513396
RPD(1004.9fb1.0500)-usport1: Ifindex = 513397
RPD(1004.9fb1.0500)-dsport0: Ifindex = 515444
```

where, 513396 is the ifIndex for usport0.

3. Configure the upstream channel.

```
Router#scm rpd name shelf-node5
```



```

D
MAC Address      IP Address      I/F            MAC            Prim  RxPwr  Timing Num
I Dev
                                     State          Sid   (dBmV) Offset CPE
P Class
4800.33ee.dc6e  12.0.1.34      C7/0/9/UB     w-online (pt)  1    -0.50  1176  0
N CM
5039.5577.0bbc  12.0.1.42      C7/0/10/U0    online (pt)    1    0.00   866   0
N CM
5039.5577.06e2  12.0.1.43      C7/0/10/U0    online (pt)    2    0.00   867   0
N CM

```

To verify an upstream ranging class ID of a cable modem, use the **show cable modem** command with the **verbose** keyword.

Following is a sample output of the **show cable modem verbose** command:

```

Router#show cable modem 4458.2945.2da6 verbose

MAC Address          : 4458.2945.2da6
IP Address           : 91.7.0.6
IPv6 Address         : ---
Dual IP              : N
Prim Sid             : 1
Host Interface       : C9/0/11/UB
RPD ID               : 1004.9fb1.0500
MD-DS-SG / MD-US-SG : 1 / 1
MD-CM-SG             : 0x15B0101
Primary Wideband Channel ID : 58625 (Wi9/0/5:0)
Primary Downstream   : Do9/0/5:3 (RfId : 58627, SC-QAM)
Wideband Capable     : Y
DS Tuner Capability  : 8
RCP Index            : 3
RCP ID               : 00 10 00 00 08
Downstream Channel DCID RF Channel : 4    9/0/5:3 (SC-QAM)
Downstream Channel DCID RF Channel : 1    9/0/5:0 (SC-QAM)
Downstream Channel DCID RF Channel : 2    9/0/5:1 (SC-QAM)
Downstream Channel DCID RF Channel : 3    9/0/5:2 (SC-QAM)
Downstream Channel DCID RF Channel : 5    9/0/5:4 (SC-QAM)
Downstream Channel DCID RF Channel : 6    9/0/5:5 (SC-QAM)
Downstream Channel DCID RF Channel : 7    9/0/5:6 (SC-QAM)
Downstream Channel DCID RF Channel : 8    9/0/5:7 (SC-QAM)
UDC Enabled          : N
US Frequency Range Capability : Standard (5-42 MHz)
Extended Upstream Transmit Power : 0dB
Multi-Transmit Channel Mode : Y
Max US SC-QAMs Supported : 4
Number of US in UBG : 1
Minimum power load in DRW (dB) : 16.50
Upstream Channel : US0
Device ID            : 0
Ranging Status       : sta
Upstream SNR (dB)    : 38.16
Upstream Data SNR (dB) : 41.55
Received Power (dBmV) : 0.00

```

```
Router#show cable modem 4458.2945.2da6
```

```

D
MAC Address      IP Address      I/F            MAC            Prim  RxPwr  Timing Num
I Dev
                                     State          Sid   (dBmV) Offset CPE
P

```

```
4458.2945.2da6 91.7.0.6          C9/0/11/UB    w-online (pt) 1    0.00  868    0
N
```

#### 4. Configure the upstream channel ifIndex.

To identify the SNMP ifIndex value, execute the following show command:

```
Router#show snmp mib ifmib ifindex | s 9/0/11
Cable9/0/11: Ifindex = 1348
Cable9/0/11-upstream0: Ifindex = 502392
Cable9/0/11-upstream1: Ifindex = 502393
Cable9/0/11-upstream2: Ifindex = 502394
Cable9/0/11-upstream3: Ifindex = 502395
Cable9/0/11-upstream4: Ifindex = 502396
Cable9/0/11-upstream5: Ifindex = 502397
Cable9/0/11-upstream6: Ifindex = 502398
Cable9/0/11-upstream7: Ifindex = 502399
Cable9/0/11-upstream8: Ifindex = 502400
Cable9/0/11-upstream9: Ifindex = 502401
Cable9/0/11-upstream10: Ifindex = 502402
Cable9/0/11-upstream11: Ifindex = 502403
Cable9/0/11-upstream12: Ifindex = 502404
Cable9/0/11-upstream13: Ifindex = 502405
Cable9/0/11-upstream14: Ifindex = 502406
Cable9/0/11-upstream15: Ifindex = 502407
```

#### 5. Configure the upstream channel center frequency.

#### 6. Start the CM-MAC capture.

The following is an example of the SNMP command configuration to start the CM-MAC trigger mode capture:

```
snmpset -v2c -c private 20.5.1.49 1.3.6.1.4.1.4491.2.1.27.1.3.10.2.1.21.415082.1 i 6
snmpset -v2c -c private 20.5.1.49 1.3.6.1.4.1.4491.2.1.27.1.3.10.2.1.21.415082.1 i 4
snmpset -v2c -c private 20.5.1.49 1.3.6.1.4.1.4491.2.1.27.1.3.10.2.1.2.415082.1 i 404045
snmpset -v2c -c private 20.5.1.49 1.3.6.1.4.1.4491.2.1.27.1.3.10.2.1.3.415082.1 i 6
snmpset -v2c -c private 20.5.1.49 1.3.6.1.4.1.4491.2.1.27.1.3.10.2.1.6.415082.1 x "48
00 33 ee dd 9e"
snmpset -v2c -c private 20.5.1.49 1.3.6.1.4.1.4491.2.1.27.1.3.10.2.1.8.415082.1 u 16400000
snmpset -v2c -c private 20.5.1.49 1.3.6.1.4.1.4491.2.1.27.1.3.10.2.1.9.415082.1 u 6400000
snmpset -v2c -c private 20.5.1.49 1.3.6.1.4.1.4491.2.1.27.1.3.10.2.1.10.415082.1 u 4096
snmpset -v2c -c private 20.5.1.49 1.3.6.1.4.1.4491.2.1.27.1.3.10.2.1.11.415082.1 u 245
snmpset -v2c -c private 20.5.1.49 1.3.6.1.4.1.4491.2.1.27.1.3.10.2.1.13.415082.1 u
10240000
snmpset -v2c -c private 20.5.1.49 1.3.6.1.4.1.4491.2.1.27.1.3.10.2.1.14.415082.1 u
25600000
snmpset -v2c -c private 20.5.1.49 1.3.6.1.4.1.4491.2.1.27.1.3.10.2.1.15.415082.1 i -200
snmpset -v2c -c private 20.5.1.49 1.3.6.1.4.1.4491.2.1.27.1.3.10.2.1.16.415082.1 i 3
snmpset -v2c -c private 20.5.1.49 1.3.6.1.4.1.4491.2.1.27.1.3.10.2.1.17.415082.1 i 1
snmpset -v2c -c private 20.5.1.49 1.3.6.1.4.1.4491.2.1.27.1.3.10.2.1.18.415082.1 u 25000
snmpset -v2c -c private 20.5.1.49 1.3.6.1.4.1.4491.2.1.27.1.3.10.2.1.19.415082.1 u 5000
snmpset -v2c -c private 20.5.1.49 1.3.6.1.4.1.4491.2.1.27.1.3.10.2.1.20.415082.1 u 1000
snmpset -v2c -c private 20.5.1.49 1.3.6.1.4.1.4491.2.1.27.1.3.10.2.1.21.415082.1 i 1
snmpset -v2c -c private 20.5.1.49 1.3.6.1.4.1.4491.2.1.27.1.3.10.2.1.24.415082.1 u 1
snmpset -v2c -c private 20.5.1.49 1.3.6.1.4.1.4491.2.1.27.1.3.10.3.1.1.415082.1 i 1
```

where, 404045 is the upstream channel ifIndex, 16400000 is the center frequency, 4096 is the number of bins.

#### Verifying the CM-MAC Capture:

The following is an example of the SNMP command configuration to verify the CM-MAC trigger mode capture:

```
$ snmpwalk -v2c -c private 20.5.1.49 1.3.6.1.4.1.4491.2.1.27.1.3.10.2.1
```

```
Router#test cable pnm bdt config get-ip
```

```
BDT TABLE ip addresses:
```

```
The destination index : 1
The assigned IP is type : 1
IPv4: 20.1.0.33
IPv6: ---
```

```
The destination index : 2
The assigned IP is type : 1
IPv4: 10.79.196.143
IPv6: ---
```

```
The destination index : 3
The assigned IP is type : 1
IPv4: 20.1.0.33
IPv6: ---
```

```
BDT V0 TFTP details:
```

```
The assigned IP is type: 1
IPv4: 20.1.0.33
IPv6: ---
```

```
Router#test cable pnm uts configure show 0 client-id 1 1004.9fb1.0500 0
```

```
Acquire capcfg for capture entry success, ret: No error
```

```
Capture Config params for client 1 on clc 9/0/8
```

```
utsc config index      1
BDT TFTP dest index   1
physical channel      0
logical channel       502392
snmp ifIndex          513396
trigger-mode          cm-mac-add
frequency              16800000
span                   6400000
bins                   1100
window mode           hann
output format         fft-pwr
repeat-period         100000
duration               300000
trigger-count         3000
capcfg entry status   active
minislot count        0
sid                   1
timestamp             0
cm-mac                4458.2945.2da6
averaging              8
qualify frequency     10240000
qualify bandwidth     25600000
qualify threshold     -200
```

```
Router#test cable pnm uts show
```

```
--- PNM UTSC Activity ---
```

```
CLC 9/0/8 dev 0 client 1 test 1 in progress
```

```
RphyNode-L09#
```

Verify the spectrum capabilities using the following show command:

```
Router#show cable card 9/0 us-triggered-spectrum uts-common
```

Last event

```

UTSCOM event   STATUS
  client_id    1
  test_id     1
  port        8
  dev         0
  phys_chan   22740992
  logi_chan    1
  status      3

```

Port 8 Dev 0 configuration

```

UTSCOM event   START
  client_id    1
  test_id     1
  port        8
  dev         0
  phys_chan   22740992
  logi_chan    1
  sac index    1
  trigger-mode 6
  frequency   16800000
  span        6400000
  bins        1100
  window      3
  output      2
  repeat-period 100000
  duration    300000
  trigger-count 3000
  qual-center-freq 10240000
  qual-bw     25600000
  qual-threshld -200
WBFFT Dev      port, devId, trig-mode,data-ready, packets on WBFFT dev, countdown:
wbfft dev 0:   8      0 6      1      156      2938
wbfft dev 1:  64      8 0      0      0        0
wbfft dev 2:  64      8 0      0      0        0
wbfft dev 3:  64      8 0      0      0        0
wbfft dev 4:  64      8 0      0      0        0
wbfft dev 5:  64      8 0      0      0        0
wbfft dev 6:  64      8 0      0      0        0
wbfft dev 7:  64      8 0      0      0        0
total packets: 156

```

Verify the frequency from the running configuration:

```

Router#show run | s rpd140
cable rpd rpd140
  identifier 1004.9fb1.0500
  type shelf
  rpd-ds 0 base-power 25
  core-interface Te9/1/1
  principal
  rpd-ds 0 downstream-cable 9/0/5 profile 3
  rpd-us 0 upstream-cable 9/0/8 profile 1
  rpd-us 1 upstream-cable 9/0/9 profile 1
  rpd-ds 0 static-pseudowire ndfviavi0 profile 2
  rpd-us 0 static-pseudowire viavi0 profile 2
r-dti 2

```

```
rpd-event profile 0
rpd-55d1-us-event profile 0
```

To verify the upstream controller profile configuration, use the following show command:

```
Router#show run | s upstream controller-profile 1
cable upstream controller-profile 1
  us-channel 0 channel-width 3200000 3200000
  us-channel 0 docsis-mode atdma
  us-channel 0 frequency 11400000
  us-channel 0 minislots-size 2
  us-channel 0 modulation-profile 221
  no us-channel 0 shutdown
  us-channel 1 channel-width 3200000 3200000
  us-channel 1 docsis-mode atdma
  us-channel 1 frequency 14600000
  us-channel 1 minislots-size 2
  us-channel 1 modulation-profile 221
  no us-channel 1 shutdown
  us-channel 2 channel-width 3200000 3200000
  us-channel 2 docsis-mode atdma
  us-channel 2 frequency 17800000
  us-channel 2 minislots-size 2
  us-channel 2 modulation-profile 221
```

## Bulk Data Transfer for Other Trigger Mode

Bulk Data Transfer can support three multiple bulkDataTransferCfg MIB, and the index value starts from 1 to 3.

The following is an example of the steps that are required for PNM BDT bulkDataTransferCfg MIB configuration with multiple destination indexes for the Other trigger mode:

### 1. Row: Create a BDT entry.

```
snmpset -v2c -c private x.x.x.x 1.3.6.1.4.1.4491.2.1.27.1.1.3.1.1.9.1 i 4
```

### 2. IP Type: Set a Destination IP type.

```
snmpset -v2c -c private x.x.x.x 1.3.6.1.4.1.4491.2.1.27.1.1.3.1.1.3.1 i 1
```

### 3. Destination IP address: Set the destination IP address.

```
snmpset -v2c -c private x.x.x.x 1.3.6.1.4.1.4491.2.1.27.1.1.3.1.1.4.1 x "14 01 00 21"
```

### 4. Uri: Set TFTP URL format.

```
snmpset -v2c -c private x.x.x.x 1.3.6.1.4.1.4491.2.1.27.1.1.3.1.1.6.1 s
tftp://20.1.0.33/jiexiao/PNM
```

The following configuration is an example with index 2 for Other trigger mode:

```
snmpset -v2c -c private x.x.x.x 1.3.6.1.4.1.4491.2.1.27.1.1.3.1.1.9.2 i 4
snmpset -v2c -c private x.x.x.x 1.3.6.1.4.1.4491.2.1.27.1.1.3.1.1.3.2 i 1
snmpset -v2c -c private x.x.x.x 1.3.6.1.4.1.4491.2.1.27.1.1.3.1.1.4.2 x "0a 4f c4 8f"
snmpset -v2c -c private x.x.x.x 1.3.6.1.4.1.4491.2.1.27.1.1.3.1.1.6.2 s
tftp://10.79.196.143/PNM
```

The following configuration is an example with index 3 for Other trigger mode:

```
snmpset -v2c -c private x.x.x.x 1.3.6.1.4.1.4491.2.1.27.1.1.3.1.1.9.3 i 4
snmpset -v2c -c private x.x.x.x 1.3.6.1.4.1.4491.2.1.27.1.1.3.1.1.3.3 i 1
snmpset -v2c -c private x.x.x.x 1.3.6.1.4.1.4491.2.1.27.1.1.3.1.1.4.3 x "14 01 00 22"
```

```
snmpset -v2c -c private x.x.x.x 1.3.6.1.4.1.4491.2.1.27.1.1.3.1.1.6.3 s
tftp://20.1.0.34/jiexiao/WBFFT
```

The following configuration is an example of IPv6 for UTSC Other trigger mode:

```
snmpset -v2c -c private x.x.x.x 1.3.6.1.4.1.4491.2.1.27.1.1.3.1.1.9.1 i 4
snmpset -v2c -c private x.x.x.x 1.3.6.1.4.1.4491.2.1.27.1.1.3.1.1.3.1 i 2
snmpset -v2c -c private x.x.x.x 1.3.6.1.4.1.4491.2.1.27.1.1.3.1.1.4.1 x "20 01 00 03 00
00 00 00 00 00 00 00 00 01 99"
snmpset -v2c -c private x.x.x.x 1.3.6.1.4.1.4491.2.1.27.1.1.3.1.1.6.1 s
tftp://[2001:3::199]/utsc
```



---

**Note** You must configure both TFTP IP and BDT URI to initiate the UTSC capture.

---

```
RPHY#test cable pnm bdt config get-ip
BDT TABLE ip addresses:
The destination index : 1
The assigned IP is type : 1
IPv4: 20.1.0.33
IPv6: ---

The destination index : 2
The assigned IP is type : 1
IPv4: 10.79.196.143
IPv6: ---

The destination index : 3
The assigned IP is type : 1
IPv4: 20.1.0.33
IPv6: ---

BDT V0 TFTP details:
The assigned IP is type: 0
IPv4: ---
IPv6: ---

CHN3-RACK3-RPHY#test cable pnm bdt config get-path

BDT TABLE TFTP path:

Destination Index = 1 : TFTP path is = tftp://20.1.0.33/jiexiao/PNM
Destination Index = 2 : TFTP path is = tftp://10.79.196.143/PNM
Destination Index = 3 : TFTP path is = tftp://20.1.0.33/jiexiao/WBFFT

RPHY#test cable pnm bdt config row-status
BDT TABLE Row status:

Destination Index = 1 : Row status is = 1
Destination Index = 2 : Row status is = 1
Destination Index = 3 : Row status is = 1
```

## High-Split Upstream Spectrum Capture Support

This feature allows 409.6M span to be configured with Upstream Triggered Spectrum Capture “other” mode for cBR-8 routers. This allows the full spectrum capture range of 0 MHz to 204.8MHz to be supported. Pass through occurs on cBR-8. L2TP packets go directly to a Viavi RCI Agent.

**BCM Chip Limitation:**

- When sample rate is set as 204.8 MHz, useful span = 204.8 MHz \* 80% = 163.84 MHz
- When sample rate is set as 409.6 MHz, useful span = 409.6 MHz \* 80% = 327.68 MHz

**Limitations**

- Only accepts span greater than 204.8MHz when trigger mode is `other`.
- Any span greater than 204.8MHz is converted to 409.6MHz on the RPD side.
- Resolution is 100KHz for span greater than 204.8MHz and bin size is equal to 4096.

**Example**

- Center Frequency = 153.6MHz
- Span = 307.2MHZ (adopt to 409.6MHz on RPD)
- Reported frequency range [-51.2 MHz to 358.4MHz]
- Expected frequency range [0 MHz to 204.8MHz] need to extract from bin data [512, 2560]

## Multiple Spectrum Acquisition Circuits on a Single Port

*Table 157: Feature History*

| Feature Name                                            | Release Information         | Feature Description                                                       |
|---------------------------------------------------------|-----------------------------|---------------------------------------------------------------------------|
| Multiple Spectrum Acquisition Circuits on a single port | Cisco IOS XE Dublin 17.12.1 | You can now configure two Spectrum Acquisition Circuits on a single port. |

Starting with Cisco IOS XE Dublin 17.12.1, you can configure two spectrum acquisition circuits (MIG-I-4365) on a single port at the same time and two UTSC configuration entries are supported. Prior to Cisco IOS XE Dublin 17.12.1, only one UTSC configuration entry was supported. The receiver (Cox) collects TimeIQ and spectrum FFT data for a single port.

cBR-8 reads the spectrum acquisition circuits supported trigger mode from the RPD reported capabilities.

The following are the supported trigger modes that have to be mapped to the spectrum acquisition circuits type:

- Other or FreeRun trigger mode for wide band.
- CM-MAC trigger mode for narrow band.



- Note**
- When the required spectrum acquisition circuits are in the operation mode, the capture start operation fails.
  - You cannot configure two FreeRun or other trigger mode on the same RPD.
  - You cannot configure two CM-MAC trigger mode on the same port.

The receiver (BCM3161) supports multiple spectrum acquisition circuits and has:

- Two Narrow band spectrum acquisition circuits—Captures on one delegated upstream port.
- One Wide band spectrum acquisition circuits—Captures on one of the two upstream ports.

## Configuring Multiple Spectrum Acquisition Circuits on a Single Port

The following example shows how to create two rows for the UTSC configuration:

```
snmpset -v2c -c private 10.74.59.202 1.3.6.1.4.1.4491.2.1.27.1.3.10.2.1.21.513439.1 i 4
snmpset -v2c -c private 10.74.59.202 1.3.6.1.4.1.4491.2.1.27.1.3.10.2.1.21.513439.2 i 4
```

The SNMP walk is supported for the upstream triggered spectrum capture.

The following is an example of the SNMP walk on the upstream triggered spectrum capture configuration parameter:

For BCM3161, the configuration 1 is for the OTHER trigger mode and configuration 2 is for the CM-MAC trigger mode running on the same port.

```
$ snmpwalk -v2c -c private 10.74.59.202 1.3.6.1.4.1.4491.2.1.27.1.3.10.2.1.3.513439
iso.3.6.1.4.1.4491.2.1.27.1.3.10.2.1.3.513439.1 = INTEGER: 1
iso.3.6.1.4.1.4491.2.1.27.1.3.10.2.1.3.513439.2 = INTEGER: 6

$ snmpset -v2c -c private 10.74.59.202 1.3.6.1.4.1.4491.2.1.27.1.3.10.3.1.1.513439.1 i 1
iso.3.6.1.4.1.4491.2.1.27.1.3.10.3.1.1.513439.1 = INTEGER: 1
$ snmpset -v2c -c private 10.74.59.202 1.3.6.1.4.1.4491.2.1.27.1.3.10.3.1.1.513439.2 i 1
iso.3.6.1.4.1.4491.2.1.27.1.3.10.3.1.1.513439.2 = INTEGER: 1

$ snmpwalk -v2c -c private 10.74.59.202 1.3.6.1.4.1.4491.2.1.27.1.3.10.4.1.1.513439
iso.3.6.1.4.1.4491.2.1.27.1.3.10.4.1.1.513439.1 = INTEGER: 3
iso.3.6.1.4.1.4491.2.1.27.1.3.10.4.1.1.513439.2 = INTEGER: 3
```

## Verifying the Spectrum Acquisition Circuits Configuration

To verify the spectrum acquisition circuits capabilities sent from cBR-8, execute the following show command:

```
Router#show cable rpd
Load for five secs: 6%/1%; one minute: 7%; five minutes: 8%
Time source is NTP, 18:04:00.099 CST Mon Jul 10 2023

MAC Address IP Address I/F State Role HA Auth Name
0018.48fe.e643 30.85.65.150 Te6/1/5 online Pri Act N/A vecima-rpd
1004.9fb1.1300 30.85.65.152 Te6/1/5 online Pri Act N/A ng13-shelf-node2

! = PTP clock out of phaselock occurred, ^ = Default password in use

Router#show cable rpd 0018.48fe.e643 spectrum-capture-capabilities
Load for five secs: 18%/1%; one minute: 8%; five minutes: 8%
Time source is NTP, 18:04:08.239 CST Mon Jul 10 2023
```



```
RPD ID : 0018.48fe.e643
NumSacs : 4
SacIndex : 0

SacDescription : Wideband spectrum analysis circuit, upstream RF ports 0 & 0
MaxCaptureSpan : 409600000 Hz
MinimumCaptureFrequency : 0 Hz
MaximumCaptureFrequency : 409600000 Hz
SupportedTriggerModes : |freeRunning|miniSlotCount|sid|burstIuc|timestamp|
SupportedOutputFormats : |timeIQ|fftPower|fftIQ|fftAmplitude|
SupportedWindowFormats : |rectangular|hann|blackmanHarris|hamming|flatTop|gaussian|chebyshev|
SupportsAveraging : Support
SupportedAggregationMethods : None
SupportsSpectrumQualification : Not Support
MaxNumBins : 4096
MinNumBins : 256
MinRepeatPeriod : 100000 us
SupportedTrigChanTypes : |OFDMA|
PwType : |PNM PW|
LowestCapturePort : 0
HighestCapturePort : 0
SupportsScanningCapture : Not Support
MinScanningRepeatPeriod : 0 ms

RPD ID : 0018.48fe.e643
NumSacs : 4
SacIndex : 1

SacDescription : Narrowband spectrum analysis circuit, upstream RF port 0
MaxCaptureSpan : 204800000 Hz
MinimumCaptureFrequency : 0 Hz
MaximumCaptureFrequency : 85120000 Hz
SupportedTriggerModes : |freeRunning|miniSlotCount|sid|burstIuc|
SupportedOutputFormats : |timeIQ|fftPower|fftIQ|fftAmplitude|
SupportedWindowFormats : |rectangular|hann|blackmanHarris|hamming|flatTop|gaussian|chebyshev|
SupportsAveraging : Support
SupportedAggregationMethods : None
SupportsSpectrumQualification : Not Support
MaxNumBins : 4096
MinNumBins : 256
MinRepeatPeriod : 100000 us
SupportedTrigChanTypes : |SC-QAM|
PwType : |SpecMan PW|
LowestCapturePort : 0
HighestCapturePort : 0
SupportsScanningCapture : Not Support
MinScanningRepeatPeriod : 0 ms

RPD ID : 0018.48fe.e643
NumSacs : 4
SacIndex : 3

SacDescription : Wideband spectrum analysis circuit, upstream RF ports 1 & 1
MaxCaptureSpan : 409600000 Hz
MinimumCaptureFrequency : 0 Hz
MaximumCaptureFrequency : 409600000 Hz
SupportedTriggerModes : |freeRunning|miniSlotCount|sid|burstIuc|timestamp|
SupportedOutputFormats : |timeIQ|fftPower|fftIQ|fftAmplitude|
SupportedWindowFormats : |rectangular|hann|blackmanHarris|hamming|flatTop|gaussian|chebyshev|
SupportsAveraging : Support
SupportedAggregationMethods : None
SupportsSpectrumQualification : Not Support
MaxNumBins : 4096
MinNumBins : 256
MinRepeatPeriod : 100000 us
```

```

SupportedTrigChanTypes : |OFDMA|
PwType : |PNM PW|
LowestCapturePort : 1
HighestCapturePort : 1
SupportsScanningCapture : Not Support
MinScanningRepeatPeriod : 0 ms

RPD ID : 0018.48fe.e643
NumSacs : 4
SacIndex : 4

SacDescription : Narrowband spectrum analysis circuit, upstream RF port 1
MaxCaptureSpan : 204800000 Hz
MinimumCaptureFrequency : 0 Hz
MaximumCaptureFrequency : 85120000 Hz
SupportedTriggerModes : |freeRunning|miniSlotCount|sid|burstIuc|
SupportedOutputFormats : |timeIQ|fftPower|fftIQ|fftAmplitude|
SupportedWindowFormats : |rectangular|hann|blackmanHarris|hamming|flatTop|gaussian|chebyshev|
SupportsAveraging : Support
SupportedAggregationMethods : None
SupportsSpectrumQualification : Not Support
MaxNumBins : 4096
MinNumBins : 256
MinRepeatPeriod : 100000 us
SupportedTrigChanTypes : |SC-QAM|
PwType : |SpecMan PW|
LowestCapturePort : 1
HighestCapturePort : 1
SupportsScanningCapture : Not Support
MinScanningRepeatPeriod : 0 ms

```

## UTSC CM-MAC for Third-Party RPD

*Table 158: Feature History*

| Feature Name                    | Release Information         | Feature Description                                                                                                                                                                                              |
|---------------------------------|-----------------------------|------------------------------------------------------------------------------------------------------------------------------------------------------------------------------------------------------------------|
| UTSC CM-MAC for third-party RPD | Cisco IOS XE Dublin 17.12.1 | cBR-8 now supports the suitable spectrum acquisition circuit and sends the related spectrum acquisition circuit index for the CM-MAC trigger mode. The UTSC CM-MAC works with the Cisco RPD and third-party RPD. |

cBR-8 uses a spectrum acquisition circuit for a third-party capture in the CM-MAC mode. The CM-MAC is for NBFFT, and only uses the SPECMAN session. The capture supports narrow band spectrum for a modem on a used upstream channel.

cBR-8 supports the IQ-FFT data based on the CM-MAC trigger mode on the PNM upstream capture for NBFFT. This process initiates sampling data on a grant for any SID assigned to CM-MAC. Then the CCAP receives the burst corresponding to the grant to perform the spectrum analysis capture.

The spectrum acquisition circuit index is selected from the reported capture capabilities list. The capture is triggered between PNM and UTSC. The high and low bin sessions are removed from the port and the correct PNM or SPECMAN sessions are retained for each spectrum acquisition circuit entity.

In the CM-MAC trigger mode, a SPECMAN dynamic session per channel per port is established. This session helps to communicate between the Cisco RPD and the third-party RPD. A specified MAC address defining a SID is triggered. Each available upstream channel establishes a SPECMAN session by default. For the CM-MAC trigger mode to work, ensure that you add the dynamic PNM standby sessions setup when the RPD is online.



**Note** The CM-MAC trigger mode supports LCHA and SUPHA.

When there are configuration updates to the RPD, the RPD reconnects, and the CM-MAC trigger mode works under the following conditions:

- cBR-8 first checks if it is a CM-MAC trigger mode.
- cBR-8 sets up the dynamic PNM session, only after the RPD is online.

### Example: Sample Configuration for UTSC CM-MAC for Third-Party RPD

Configure upstream channel ifIndex

```
snmpset -v2c -c private 20.5.1.49 1.3.6.1.4.1.4491.2.1.27.1.3.10.2.1.2.415082.1 i 404045
```

Configure trigger mode CM-MAC

```
snmpset -v2c -c private 20.5.1.49 1.3.6.1.4.1.4491.2.1.27.1.3.10.2.1.3.415082.1 i 6
```

Configure CM-MAC

```
snmpset -v2c -c private 20.5.1.49 1.3.6.1.4.1.4491.2.1.27.1.3.10.2.1.6.415082.1 x "48 00
33 ee dd 9e"
```

Configure center frequency

```
snmpset -v2c -c private 20.5.1.49 1.3.6.1.4.1.4491.2.1.27.1.3.10.2.1.8.415082.1 u 16400000
```

```
snmpset -v2c -c private 20.5.1.49 1.3.6.1.4.1.4491.2.1.27.1.3.10.2.1.9.415082.1 u 6400000
```

Configure bins

```
snmpset -v2c -c private 20.5.1.49 1.3.6.1.4.1.4491.2.1.27.1.3.10.2.1.10.415082.1 u 4096
```

## Configuring the PNM MAX-HOLD UTSC Other Trigger Mode

When RPHY configuration is for PNM MAX-HOLD UTSC Other trigger mode, RPHY sends PNM data continuously, until the user issues stop command or the duration is complete.

To configure for MAX-HOLD trigger mode on the Supervisor, complete the following steps:

**Step 1** Configure the PNM `docsPnmCmtsUtseCfgTriggerMode` to 'other' mode. Both the SNMP and CLI can set the trigger mode. See the following examples:

- For SNMP:

```
snmpset -v2c -c private 80.4.2.11 1.3.6.1.4.1.4491.2.1.27.1.3.10.2.1.3.435572.1 i 1
```

- For CLI:

```
test cable pnm uts configure trigger-mode other
```

Adding a new TrigMode to MIB might take long and cause many specification changes.

**Step 2** Set the PNM bulk destination IP address.

- For SNMP:

```
snmpset -v2c -c private 80.4.2.11 1.3.6.1.4.1.4491.2.1.27.1.1.1.2.0 x "20 01 0d b8"
```

- For CLI:

```
test cable pnm bdt config set-ip 32.1.13.184
```

**Step 3** Start and stop the capture test.

- Starting the SNMP:

```
snmpset -v2c -c private 80.4.2.11 1.3.6.1.4.1.4491.2.1.27.1.3.10.3.1.1.435572.1 i 1
```

- Starting the CLI:

```
test cable pnm uts start client-id 1 test-id 1 0004.9f00.0591 0
```

- Stopping the SNMP:

```
snmpset -v2c -c private 80.4.2.11 1.3.6.1.4.1.4491.2.1.27.1.3.10.3.1.1.435572.1 i 0
```

- Stopping the CLI:

```
test cable pnm uts stop client-id 1 test-id 1 0004.9f00.0591 0
```

**Step 4** Enable GCP message support. Send the TFTP server IP address and Static L2TP session ID through TLV58 message, and the TrigMode 'other' is send to RPD through TLV41 message.

## Proactive Network Management MAX-HOLD trigger mode

*Table 159: Feature History*

| Feature Name                     | Release Information         | Feature Description                                                                                                                                                                                                                                                                                                                                                                                                                                                                       |
|----------------------------------|-----------------------------|-------------------------------------------------------------------------------------------------------------------------------------------------------------------------------------------------------------------------------------------------------------------------------------------------------------------------------------------------------------------------------------------------------------------------------------------------------------------------------------------|
| Support for 262144 L2TP sessions | Cisco IOS XE Dublin 17.12.1 | <p>The maximum number of L2TP sessions is increased from 131072 to 262144. The benefit of having more L2TP sessions is that it enables better support for large-scale RPD deployments.</p> <p><b>Note:</b></p> <p>System logs are created when the number of sessions get close 262144. Configure the <b>memory chunk siblings threshold 20000</b> command, to eliminate system logs.</p> <p>The <b>rate-limit</b> warning is logged when L2TP session number is greater than 262144.</p> |

The cBR enables MAX-HOLD trigger mode support in PNM. The non-CCAP defined MAX-HOLD mode offers significant advantages over the existing FREE-RUN mode that was used earlier. With the MAX-HOLD trigger mode, the RPD sends samples much faster - one sample every 2ms, compared to the earlier rate of one sample per 100ms. The RPD also sends the sample to the server, instead of the Line Card.

The MAX-HOLD trigger mode support functionality includes:

- cBR support for the configuration of the MAX-HOLD trigger mode
- cBR support for notify UBUNTU server IP and Static L2tp session IDs to RPD
- RPD usage of the max hold mode to capture the upstream spectrum
- RPD sending the captured BIN to UBUNTU server

## Debugging the PNM feature on cBR8

cBR supports debugging on Upstream Triggered Spectrum Capture – Proactive Network Management by using the debug commands available for the UTSCOM client on supervisor.

Use the CLI to enable the debug commands:

- **debug cable pnm utscom-error**
- **debug cable pnm utscom-debug**

Use the following show command to check the state of capture on the Line Card. It lists the total number of samples per capture context in the CLC. When the capture tests are running, the packet counts on the corresponding Line Card would keep incrementing.

```
Router# show cable card 6/0 us-triggered-spectrum uts-commonLAST event
UTSCOM event      STATUS
client_id         1
test_id           1
port              0
dev               8
phy_chan          0
logi_chan         0
status            4
WBFFT   Dev      trig-mode,   data-ready,   packets on WBFFT dev,   countdown :
wbfft   dev 0:    0             0             11                0
wbfft   dev 1:    0             0              0                0
wbfft   dev 2:    0             0              0                0
wbfft   dev 3:    0             0              0                0
wbfft   dev 4:    0             0              0                0
wbfft   dev 5:    0             0              0                0
wbfft   dev 6:    0             0              0                0
wbfft   dev 7:    0             0              0                0
total packets: 11
```

The **dtrack** utility can also be used for debugging the packets punted through CPP from CLC to container. To use the **dtrack** utility, complete the following steps:

1. On the supervisor, use the following CLI:

```
test platform hardware qfp active feature docsis dtrack mac 0001.aaaa.cccc
test platform hardware qfp active feature docsis dtrack packe
```

2. Start the trigger and use the following CLI to dump the packets (this can be very verbose as there are 10 samples per file per second):

```
show platform hardware qfp active feature docsis dtrack statistics verbose
```

To obtain the dumping statistics on the IOX container, use the following CLI:

- **dir** `harddisk:/iox/repo-lxc/lxc-data/<CAF id>/logs/`
- **more** `harddisk:/iox/repo-lxc/lxc-data/<CAF id>/logs/.stats`
- **more** `harddisk:/iox/repo-lxc/lxc-data/<CAF id>/logs/pnm.log`

To change configuration on the container console, complete the following steps:

1. Log onto the CAF console as root.
2. Run the `echo "DEBUG" > /data/logs/.loglevel` command.

```
debug level are: ERROR, WARNING, INFO, DEBUG, DEBUG1, DEBUG2, DEBUG3, DEBUG4
```

3. Run the `echo "0" > /data/logs/.resend` command.

```
value "0" disable "tftp resend" due to tftp error.
value "12" enable clc log pnm file at local.
```

Ensure that the PNM TFTP process is active and running on the `guestshell` container as listed:

```
cbr8# guestshell run systemctl status pnm
â pnm.service - cbr pnm telemetry delivery system
Loaded: loaded (/etc/systemd/system/pnm.service; disabled; vendor preset: disabled)
Active: active (running) since Wed 2019-01-09 15:13:40 UTC; 1min 28s ago
```

- If the PNM service is not active, attempt recovery by going through the following steps:
  1. Destroy the `guestshell` instance. Run the `guestshell destroy` command.
  2. Recreate the `gusetshell` by running the `guestshell enable` command.
  3. Check if the `guestshell` instance is running by using the `show app-hosting list` command. Verify that the PNM service is active.
- Verify that the TFTP server IP is reachable from the `guestshell` container and ping is successful.

```
guestshell run ping -c5 <tftp_server_ip>
```

## Quick Install Guide

You can bring up the Proactive Network Management and get the captures running using a minimal configuration. Complete the following steps to enable PNM with a minimal configuration:

1. Find the correct PNM Interface Index for the RPD. Run the `show snmp mib ifmib ifindex | include <rpd_mac>` command.

```
Router# show snmp mib ifmib ifindex | i badb.ad13.2be0
RPD(badb.ad13.2be0)-usport0: Ifindex = 435564
```

Where `badb.ad13.2be0` is the RPD identifier.

2. Ensure that the `guestshell` container is up and running on both active and standby SUP. Run the `show app-hosting list` command.

```
Router# show app-hosting list
App id                               State
-----
guestshell                            RUNNING
```

3. Ensure that the `pnm` process is running on the `guestshell`. Run the `guestshell run systemctl status pnm` command. For more information on the command usage, go through [Step 4, on page 728](#).

4. Configure the Bulk Data Transfer parameters. Go through the following steps to set the TFTP IP address and TFTP path. Alternatively, also go through [Upstream Triggered Spectrum Capture Bulk Data Control Objects and MIBs, on page 745](#) for detailed information.

- Set the BDT IPv4 IP address type and TFTP IP address

- **snmp** commands:

```
server > setany -v2c <cmts_ip> <community_name>
1.3.6.1.4.1.4491.2.1.27.1.1.1.2.0 -o 20:01:0d:b8

docsPnmBulkDestIpAddr.0 = 20 01 0d b8
```

- **net-snmp** commands:

```
server > snmpset -v2c -c <community_name> <cmts_ip>
1.3.6.1.4.1.4491.2.1.27.1.1.1.2.0 x 20010db8
SNMPv2-SMI::enterprises.4491.2.1.27.1.1.1.2.0 = Hex-STRING: 20 01 0D B8

server > snmpget -v2c -c <community_name> <cmts_ip>
1.3.6.1.4.1.4491.2.1.27.1.1.1.1.0
SNMPv2-SMI::enterprises.4491.2.1.27.1.1.1.1.0 = INTEGER: 1

server > snmpget -v2c -c <community_name> <cmts_ip>
1.3.6.1.4.1.4491.2.1.27.1.1.1.2.0
SNMPv2-SMI::enterprises.4491.2.1.27.1.1.1.2.0 = Hex-STRING: 20 01 0D B8
```

- Set the BDT destination TFTP path

- **snmp** commands:

```
server > setany -v2c <cmts_ip> <community_name>
1.3.6.1.4.1.4491.2.1.27.1.1.1.3.0 -o pnm
docsPnmBulkDestPath.0 = pnm
```

- **net-snmp** commands:

```
server > snmpset -v2c -c <community_name> <cmts_ip>
1.3.6.1.4.1.4491.2.1.27.1.1.1.3.0 s 'pnm/test'
SSNMPv2-SMI::enterprises.4491.2.1.27.1.1.1.3.0 = STRING: "pnm/test"

server > snmpget -v2c -c <community_name> <cmts_ip>
1.3.6.1.4.1.4491.2.1.27.1.1.1.3.0
SNMPv2-SMI::enterprises.4491.2.1.27.1.1.1.3.0 = STRING: "pnm/test"
```

5. Create and configure a capture config entry. Go through the [Upstream Triggered Spectrum Capture Control Objects and MIBs, on page 741](#) for information on creating and configuring a capture config entry.

6. Set the minimum capture config paramters that are needed (center-frequency, span and duration).

- a. Set the `D_docsPnmCmtsUtscCfgStatus_createAndGo` 4.

```
server > setany -v2c <cmts_ip> <community_name>
1.3.6.1.4.1.4491.2.1.27.1.3.10.2.1.21.<ifIndex>.1 -i 4
clabProjDocsis.27.1.3.10.2.1.21.<ifIndex>.1 = 4
```

- b. Set the `docsPnmCmtsUtscCfgCenterFreq`.

```
server > setany -v2c <cmts_ip> <community_name>
1.3.6.1.4.1.4491.2.1.27.1.3.10.2.1.8.<ifIndex>.1 -g 10240000
clabProjDocsis.27.1.3.10.2.1.8.<ifIndex>.1 = 10240000
```

- c. Set the `docsPnmCmtsUtscCfgSpan`.

```
server > setany -v2c <cmts_ip> <community_name>
1.3.6.1.4.1.4491.2.1.27.1.3.10.2.1.9.<ifIndex>.1 -g 20480000
clabProjDocsis.27.1.3.10.2.1.9.<ifIndex>.1 = 20480000
```

- d. Set the `docsPnmCmtsUtscCfgFreeRunDuration`. Increase the duration to a large value to keep the freerun capture running.

```
server > setany -v2c <cmts_ip> <community_name>
1.3.6.1.4.1.4491.2.1.27.1.3.10.2.1.19.<ifIndex>.1 -g 5000
clabProjDocsis.27.1.3.10.2.1.19.<ifIndex>.1 = 5000
```

- e. Ensure that the config entry status is active.

```
server > snmpget -v2c -c <community_name> <cmts_ip>
1.3.6.1.4.1.4491.2.1.27.1.3.10.2.1.21.<ifIndex>.1
SNMPv2-SMI::enterprises.4491.2.1.27.1.3.10.2.1.21.<ifIndex>.1 = INTEGER: 1
```



---

**Note** Ensure that the capture center frequency and span are in a valid range. IOS error messages are triggered if the user attempts to start capture tests with an invalid capture configuration. The recommended configuration values are provided in the messages.

---

7. Start the PNM capture.

- **snmpr** commands:

```
• server > setany -v2c <cmts_ip> <community_name>
1.3.6.1.4.1.4491.2.1.27.1.3.10.3.1.1.<ifIndex>.1 -i 1
clabProjDocsis.27.1.3.10.3.1.1.<ifIndex>.1 = 1
```

```
• server > getone -v2c <cmts_ip> <community_name>
1.3.6.1.4.1.4491.2.1.27.1.3.10.3.1.1.<ifIndex>.1
clabProjDocsis.27.1.3.10.3.1.1.<ifIndex>.1 = 1
```

- **net-snmp** commands:

```
• server > snmpset -v2c -c <community_name> <cmts_ip>
1.3.6.1.4.1.4491.2.1.27.1.3.10.3.1.1.<ifIndex>.1 i 1
SNMPv2-SMI::enterprises.4491.2.1.27.1.3.10.3.1.1.<ifIndex>.1 = INTEGER: 1
```

```
• server > snmpget -v2c -c <community_name> <cmts_ip>
1.3.6.1.4.1.4491.2.1.27.1.3.10.3.1.1.<ifIndex>.1
SNMPv2-SMI::enterprises.4491.2.1.27.1.3.10.3.1.1.<ifIndex>.1 = INTEGER: 1
```

8. The captures are running and files should appear on the TFTP server under the BDT TFTP path configured.



# Proactive Network Management using OFDMA RxMER Probes

Cisco cBR 16.12.1y supports Proactive Network Management using OFDMA RxMER Probes. This feature enables collection and reporting of the OFDMA channel Receive Modulation Error Ratio (RxMER) for every subcarrier.

The DOCSIS 3.1 CMTS and CM support OFDMA RxMER probes. The CM transmits signals over the OFDMA upstream channel to the CMTS. The signals are received at the upstream PHY, and each subcarrier in the OFDMA channel is evaluated. RxMER is defined as the ratio of the average power of the ideal QAM constellation to the average error-vector power. The error vector is the difference between the equalized received probe value and the known correct probe value. If some subcarriers (such as exclusion bands) cannot be measured by the CMTS, a value of 0xFF will be returned for that subcarrier.

PNM RxMER probes are initiated and controlled through SNMP MIB commands. The DOCS-PNM-MIB specification details the applicable commands under the **docsPnmCmtsUsOfdmaRxMerTable**. A single RxMER probe can be started for each OFDMA channel in the system by specifying the target cable modem mac-address. The RxMER probe results are sent to a remote TFTP server using the IOX Guestshell PNM service

The following command options are supported for **DocsPnmCmtsUsOfdmaRxMerTable**:

- **docsPnmCmtsUsOfdmaRxMerEntry.[ifIndex]**

Each row of the **DocsPnmCmtsUsOfdmaRxMerTable** is uniquely identified by the OFDMA channel ifIndex. You can identify the ifIndex of a particular OFDMA channel by running the following command:

```
Router# show snmp mib ifmib ifindex | i Cable1/0/2-upstream7 Cable1/0/2-upstream7:
Ifindex = 389839
```

- **docsPnmCmtsUsOfdmaRxMerEnable**

Set to TRUE to initiate collection of the RxMER data and send to TFTP server. Setting it to FALSE restores the MIB values to defaults.

- **docsPnmCmtsUsOfdmaRxMerCmMac**

Specifies the mac-address of the CM that performs the RxMER probe.

- **docsPnmCmtsUsOfdmaRxMerPreEq**

You can either set the value to TRUE to perform RxMER probe with Pre-Equalization, or choose to set the value to FALSE to perform RxMER probe without Pre-Equalization.



---

**Note** We recommend that probing is done with Pre-Equalization, as this will have the CM transmit on each sub-carrier using a gain that will normalize the signal arriving at the CMTS.

---

- **docsPnmCmtsUsOfdmaRxMerNumAvgs**

This is in the range of 1-255. Any integer greater than one will generate multiple probes and average the result before sending it to the TFTP server.

- **docsPnmCmtsUsOfdmaRxMerMeasStatus**

Indicates the status of the probe request [Inactive, Busy, SampleReady, Error]. See the MIB definition for complete details. Ensure that no modifications are made to other MIB fields for the table entry while the probe is in `Busy` state.

- **docsPnmCmtsUsOfdmaRxMerFileName**

Displays the name of the file written to the TFTP server. You can choose to leave it blank, and an autogenerated filename will be used. The filename is read back after the probe is complete and the status is read as `SampleReady`.



---

**Note** Do note that new file names are not autogenerated for subsequent probes. Hence, ensure that your filename value is cleared or set to a new value before initiating a subsequent probe. This will avoid the problem of new probe data overwriting information on the previous probe with the same filename.

---

- **docsPnmCmtsUsOfdmaRxMerDestinationIndex**

Specifies the multiple destination index added to the existing Upstream OFDMA RxMER.

Use the following command to configure the number of RxMER samples taken and averaged at the end of an RxMER-poll interval:

```
Router(config)#cable upstream ofdma-prof-mgmt samples-per-interval interval sample
```

You can also configure the same using the **ping docsis pnm mac-address num-avgs num-avgs**. Here is a sample configuration:

```
Router#ping docsis pnm 4800.33ef.0cca num-avgs 5
```

## PNM RxMER Probe High Availability

- **docsPnmCmtsUsOfdmaRxMerTable**

- SUPHA: In progress operation will need to be restarted by the operator after the switchover. Currently the IOX PNM service is not available after a SUP-HA event.
- LCHA: In progress operation will need to be restarted by the operator after switchover



---

**Note** When restarting the RxMER probe on the Standby Line Card, care should be taken to identify the new ifIndex of the OFMDA channel. This will be different from the Primary Line Card.

---

- LCPR: Operations that are in progress will be restarted by SUP after the LCPR completion. An internal operation timeout will restart the RxMER probe after one minute, for a maximum of three attempts. During this time, the RxMER status will remain as “Busy”.

## RxMer Probe Debugging

You can use the following command options to display the status and count of the PNM RxMER jobs.

- To display the status of PNM RxMER jobs by ifIndex, use the **test cable pnm rxmer show** command. See the following usage example:

```
Router# test cable pnm rxmer show
```

| Job | Client | ifIndex | CM-Mac         | Status   | Enable | Pre-Eq | Num-Avgs | Retry |
|-----|--------|---------|----------------|----------|--------|--------|----------|-------|
| 0   | SNMP   | 389838  | 0000.0000.0000 | INACTIVE | N      | N      | 1        | 0     |
| 0   | SNMP   | 389839  | 0000.0000.0000 | INACTIVE | N      | N      | 1        | 0     |
| 0   | SNMP   | 389933  | 0000.0000.0000 | INACTIVE | N      | N      | 1        | 0     |
| 0   | SNMP   | 389981  | 0000.0000.0000 | INACTIVE | N      | N      | 1        | 0     |
| .   | .      | .       | .              | .        | .      | .      | .        | .     |
| 0   | SNMP   | 404239  | 0000.0000.0000 | INACTIVE | N      | N      | 1        | 0     |
| 0   | SNMP   | 404246  | 0000.0000.0000 | INACTIVE | N      | N      | 1        | 0     |
| 0   | SNMP   | 404247  | 0000.0000.0000 | INACTIVE | N      | N      | 1        | 0     |

```
PNM RxMER job count 33
```

- To display the count of all the PNM RxMER jobs by ifIndex, use the **test cable pnm rxmer <ifIndex> get all** command. See the following example:

```
Router# test cable pnm rxmer 389838 get all PNM RxMER MIB for ifIndex 389838
Status: INACTIVE
CM-mac: 0000.0000.0000

Enable: False
Pre-Eq: OFF
Num-Avgs: 1
TFTP filename: <default>
```

When upstream profile management is enabled, the **show cable modem <mac> prof-mgmt upstream verbose** command can also be used to view the OFDMA RxMER probe data. The values shown should be similar to, but not exactly the same as the values reported in the TFTP upload file. This is because data was collected using probes at different times.

The RxMER probe data can also be collected and displayed directly on the CBR8 console using the **ping docsis pnm <ip-address> upstream <us-chan> ignored** command. This command will initiate a RxMER probe to the targeted cable modem upstream OFDMA channel. The **ignore** option on the command will prevent the RxMER probe results from impacting OFDMA profile management. The RxMER probe data can then be viewed on the console using the **show cable modem <ip-address> prof-mgmt upstream ignored** command. For example:

```
Router# ping docsis pnm 9.23.4.91 upstream 6 ignore
Queueing 1 MAC-layer station maintenance intervals, timeout is 80 msec:
!
Success rate is 100 percent (1/1)

cbr8# show cable modem 9.23.4.91 prof-mgmt upstream ignored
Upstream Profile Management Data (Ignored):
MAC Address          : 4800.33ea.6e3e
Number of US Chan    : 1

Ucid                 : 7
RxMer Exempt Percent : 0
RxMer Margin qDB     : 0
RxMer Threshold Percent : 2
Start Sc             : 148
```

```

End Sc : 1067
Num RxMER Measurement : 1068
Tx Time : 0h:03m:49s ago
Rx Time : 0h:03m:49s ago
MER Poll Period (min) : 5
Auto Profile Upgrade : Yes
Upgrd Dly Cnt (cur/cfg) : 0/1
Upgrd Dly rcmd IUC : none
Recommended IUC : 13
Current IUC : 13
Downgrade IUC : 13
RxMER send/recv count : 196/196
DBC : 31/31/0/0/0
      (send/succeed/err/reject/timeout)

State : Ready
Profile Downgrade : Disabled
0x0000 00000000 00000000 00000000 00000000 00000000 00000000 00000000 00000000
0x0020 00000000 00000000 00000000 00000000 00000000 00000000 00000000 00000000
0x0040 00000000 00000000 00000000 00000000 00000000 00000000 00000000 00000000
0x0060 00000000 00000000 00000000 00000000 00000000 00000000 00000000 00000000
0x0080 00000000 00000000 00000000 00000000 00000000 00000000 B3AEB0BB AEACA9B1 A8A9AEB8
0x00A0 ABADB6A7 AAB1B2AE B1B9B5A8 B4A7ABB0 A4B3ACAE AEB1BAB4 B2ADB3B4 B0B7B9B5
0x00C0 BAB3B5AA A5A3A7AB ABB2ACB1 B1B1B3AC B4ADAFAB 9DACA5AE AEB5ACB1 A6ADB4B2
0x00E0 A3B7ADBB B5ADAEB7 A8A7ABB2 9EAEBDB1 AAB1B6B7 B2AFAAB0 9BB0B1AF B7ACB5AD
0x0100 AFB0B0AF A9B7A8AB B1AEB5B1 B59FAEB3 A4ADB1B3 AFB0AEB1 AEABADB7 ABB6B9B6
0x0120 ACB7B5AE ADABB5A7 A4AEB0AA ADB2B8AB B1ADAEB6 A4B2B3AF AEB7A9AE BA9FABAC
0x0140 9AA5B5BB B1BAB9B7 B0A0A8B3 A4A0B3B6 B1A7B1B5 B1ADA9B0 A6B2B1BB AFB9ACAF
0x0160 B4A4B4A7 A2A7B6B3 B1B9ADB7 B5A1B7AD A6ADBCA8 AEB3B4AD AEB0B0B3 ADAEB3B1
0x0180 A8AEACAF B0ADB4A4 A5ACB0AF B1B7B2B0 B2A5B8AC 9FABAFB7 B7A9AFB0 B6B3B1B3
0x01A0 B7AAB1B2 ACBBADC1 A8B3AAB2 B7B1B5B5 BEB1AEB6 ADB3B1AD ACB0B1B2 B7BBAFB8
0x01C0 AFAEACB5 ACB5B1B0 AEA8ACAE B4B5B0AC B4B9ADB5 B4ADB5B6 B2B3AAAB A8AEB4AC
0x01E0 AEAFAFB5 AAFAFB0B6 ADADAAB4 ABACABB6 B3A5ABB1 ADB4B7B9 AEB6BFAF B1B5B3B0
0x0200 ACAFBAB2 B4B5B3AF B2B4B1BB B5AFADB7 B5B1B3B2 B4B0B0B3 B7B0ACB5 B1B1B0B7
0x0220 AEAACB9 B8AFACAF B7B1AFAD ADB1B3AE A9B9B0B0 B0AFB2AB ACADACB2 ACB4B2AE
0x0240 A8ABB1AF ADBBA8AC B4B1B3B4 B4AFADB8 B1AEA6AD B0AFAEAD BBB1B4B7 AEA7ADA7
0x0260 AEB2AEB5 B0AAB5B1 B3ACAFB6 B1ACB2A3 A8B7BCAA B5A9ABA9 B6B7AAA8 ACB1A9B3
0x0280 B0B1AFAA B4AEB1A9 ABACB4AF B3B4AFAC B1B0B2B1 B0B0B0B0 B5B7AEB0 B7B2B9A1
0x02A0 B1B0AFB1 AEAE4A7 ABB4B8B0 ADB0ABAE B1A9B9AD B2B1BBAF B1B4AAAF A8ADB3A9
0x02C0 BDA9B9B0 B2ADB0B2 AEAFB3B4 B0AEAAAF AEAFB4A9 B4A9ADB0 B6A9B1AB B0AFAEAB
0x02E0 B1ADA9B2 A8A9A9AC ACACB2AF A8AAB1B4 ABB0ADAD B8ADB1B6 ADB4AEAE AEB0ABB1
0x0300 B2ADACAF ABADABB7 ACA8ACAD A9AFAAB5 A9B0B1BA B1ADB4B3 ABB0AFB0 AEB0ADB2
0x0320 AFBABADB7 B0AEABA8 ABAFAFB1 A8A7ADAB B3AFAAB2 A9B1B6AE B1B0B1AE ACADB4B7
0x0340 ADB2B0AF B4B1ACA9 B7AFADB5 A9ACB1AD A6ADA6B1 AAA3A3A4 B7A5AFAA A7B2ABB4
0x0360 A8AFA7A7 A6A8ACAF ADA3B4AB A8AAB8AB A5A5ABA4 A7A8BBB1 ABA6A8A4 A79FA9A1
0x0380 AEA3AFAC B1AEABAD ACA8A7A6 B4A2A9A8 A8B2A2AB ABA2A6AE A99B9EA6 A9A59EA4
0x03A0 9FAD99A5 9FA39FA4 ABACA3A5 AA9FA9A1 9EA59AA2 9F9EAA9D A4A5A6A2 A59FA7A1
0x03C0 A09E98A0 9DA0A39F 9C9CA09F 9C999899 9695969A 9597939D 97979B9B 9C909291
0x03E0 938D9790 8B929492 998B8D95 8C85898A 8D878D87 7F7F7E83 817B847F 7E888071
0x0400 75787C76 7A707375 6C6A6D69 6C5B6565 615D5B68 55575458 554C5046 3641452B
0x0420 39402E32 16191D1A 1C223434

```

SC RxMER Distribution (Excluded SCs are ignored):

```

*: 2%
>44dB: ***** 46.95%
 44dB: ***** 21.19%
 43dB: ***** 11.30%
 42dB: ** 5.10%
 41dB: * 2.28%
 40dB: * 2.50%
 39dB: 1.08%
 38dB: 1.63%
 37dB: 0.65%
 36dB: 0.76%

```

```

35dB: 0.54%
34dB: 0.21%
33dB:
<33dB: ** 5.76%
-----100
Percent of Subcarriers

```

```

Active SC RxMER Statistics (in 1/4 dB):
Active Subcarrier RxMER Mean           : 0xAA
Active Subcarrier RxMER Standard Deviation : 0x52
Active Subcarrier RxMER Threshold Value  : 0x5F
Active Subcarrier RxMER Threshold Frequency (Hz): 46800000

```

## Proactive Network Management using OFDMA RxPwr Probes

### PNM OFDMA RxPwr MIB Overview

- Provides an estimate of the received power in a specified OFDMA channel at the F connector input of either a CMTS-integrated linecard or RPD.
- The measurement is based on upstream probes, which are typically the same probes used for pre-equalization adjustment.

#### *Proactive Network Management:*

- Provides measurement and reporting of network conditions.
- Detection of plant impairments and interference.

#### *Orthogonal Frequency-Division Multiple Access (OFDMA).*

- DOCSIS 3.1 Upstream Channel modulation scheme where multiple users are allocated to a channel in both the time and frequency domain.
- OFDMA channels have multiple subcarriers (frequency and modulation).

The following command options are supported for `docsPnmCmt UsOfdmaRxPwrTable`

```

DocsPnmCmtsUsOfdmaRxPwrEntry.
  [OFDMA channel ifIndex, CmMac]
  docsPnmCmtsUsOfdmaRxPwrEnable,
  docsPnmCmtsUsOfdmaRxPwrCmMac,
  docsPnmCmtsUsOfdmaRxPwrPreEq,
  docsPnmCmtsUsOfdmaRxPwrNumAvg,
  docsPnmCmtsUsOfdmaRxPwrOnePtSixPsd,
  docsPnmCmtsUsOfdmaRxPwrMeasStatus,

```

### PNM RxPwr MIB Details

```

DocsPnmCmtsUsOfdmaRxPwrTable
DocsPnmCmtsUsOfdmaRxPwrEntry [OFDMA channel ifIndex, CM Mac]

```

- A MIB table with rows corresponding to the OFDMA channels configured on the system.
- Each OFDMA channel is identified by a unique ifIndex.

```

router #show snmp mib ifmib ifindex | i Cable1/0/2-upstream7
Cable1/0/2-upstream7: Ifindex = 389839

```

- `docsPnmCmtsUsOfdmaRxPwrEnable`

- Set to **TRUE** to **initiate measurement** of the received power.
- Set to **FALSE** to restore MIB values to defaults.

**Example:**

```
./setany -v2c 8.23.1.1 private docsPnmCmtsUsOfdmaRxPwrEnable.389838.000000000001 -i 1
docsPnmCmtsUsOfdmaRxPwrEnable.389838.000000000001 = true(1)
```

```
router#show cable modem 0000.0000.0001 pnm us-rxpwr
MAC Address      IP Address      I/F              MAC              Num      Pre      RxPwr
TimeStamp
                                State           Avgs             Eq              (dBmv)
0000.0000.001   9.23.0.14      Ca1/0/0:u6      w-online(pt)     1         Y        -0.2
2023-03-02 14:55:52
```

```
router#test cable pnm us-rxpwr 488046 cm-mac 0000.0000.0001 get all
PNM US-RxPwr Get Entry for ifIndex 488046, CM 0000.0000.0001
  ifIndex: 488046
  chid: 6
  CM-Mac: 0000.0000.0001
  Status: SAMPLE READY (4)
  Enable: Disable (2)
  Pre-Eq: On (1)
  Num-Avgs: 1
  Rx Power: -2 (-0.2 dBmv)
  Probe Retry Cnt: 0
  Probe Configured: Y
  Partial-Mode: 0x00 (None)
  TimeStamp: 2023-03-02 14:55:52
```

- **docsPnmCmtsUsOfdmaRxPwrCmMac**: The mac-address of the modem that performs the RxPwr probe.
- **docsPnmCmtsUsOfdmaRxPwrPreEq**
  - Set **TRUE** to request modem **enable equalizer** during probe burst.  
The Upstream Controller OFDMA Channel's "equalization-coefficient" must also be enabled (default).
  - Set **FALSE** to request modem **disable equalizer** during probe burst.
  - Probing with equalizer enabled is preferred as the CM transmits on each sub-carrier using a gain that normalizes the signal arriving at the CMTS.

**Example:**

```
./setany -v2c 8.23.1.1 private docsPnmCmtsUsOfdmaRxPwrPreEq.488046.000000000001 -i 1
docsPnmCmtsUsOfdmaRxPwrPreEq.3488046.000000000001 = true(1)
```

```
router#show cable modem 0000.0000.0001 pnm us-rxpwr
MAC Address      IP Address      I/F              MAC              Num      Pre      RxPwr
TimeStamp
                                State           Avgs             Eq              (dBmv)
0000.0000.001   9.23.0.14      Ca1/0/0:u6      w-online(pt)     1         Y        ---
0
```

```
router#test cable pnm us-rxpwr 488046 cm-mac 0000.0000.0001 get all
PNM US-RxPwr Get Entry for ifIndex 488046, CM 0000.0000.0001
  ifIndex: 488046
```

```

chid: 6
CM-Mac: 0000.0000.0001
Status: INACTIVE (2)
Enable: Disable (2)
Pre-Eq: On (1)
Num-Avgs: 1
Rx Power: -255 (-25.5 dBmv)
Probe Retry Cnt: 0
Probe Configured: Y
Partial-Mode: 0x00 (None)
TimeStamp: 0

```

- **docsPnmCmtsUsOfdmaRxPwrNumAvgs**

- Range is 1-32. cBR-8 doesn't support values above 32.
- >1 generates multiple probes and average the result reported by docsPnmCmtsUsOfdmaRxPwrOnePtSixPsd

**Example:**

```

./setany -v2c 8.23.1.1 private docsPnmCmtsUsOfdmaRxPwrNumAvgs.488046.000000000001 -I 1
docsPnmCmtsUsOfdmaRxPwrNumAvgs.488046.000000000001 = 1

```

```

router# show cable modem 0000.0000.0001 pnm us-rxpwr
MAC Address      IP Address      I/F              MAC              Num      Pre      RxPwr
TimeStamp
0000.0000.001   9.23.0.14      Ca1/0/0:u6      w-online (pt)    1        N        ---
0

```

```

router #test cable pnm us-rxpwr 488046 cm-mac 0000.0000.0001 get all
PNM US-RxPwr Get Entry for ifIndex 488046, CM 0000.0000.0001
ifIndex: 488046
chid: 6
CM-Mac: 0000.0000.0001
Status: INACTIVE (2)
Enable: Disable (2)
Pre-Eq: Off (2)
Num-Avgs: 1
Rx Power: -255 (-25.5 dBmv)
Probe Retry Cnt: 0
Probe Configured: Y
Partial-Mode: 0x00 (None)
TimeStamp: 0

```

- **docsPnmCmtsUsOfdmaRxPwrOnePtSixPsd**: After triggering the measurement via Enable, wait for MeasStatus to return SampleReady and then read this MIB variable to retrieve the resulting power measurement.
- **docsPnmCmtsUsOfdmaRxMerMeasStatus**: Indicates the status of the requested measurements and result [Inactive, Busy, SampleReady, Error]

## PNM RxMER Probe High Availability

- **SUPHA**

- MIBs may be temporarily unavailable while newly active SUP completes initialization of non-dataplane subsystems after becoming active.
- SNMP architecture of cBR-8 changes the ifIndex of channels to match the currently active slot.

- In Progress operation will need to be restarted by operator after switchover for entry with ifIndex of newly active slot.

**Before Switchover:**

```
docsPnmCmtsUsOfdmaRxPwrOnePtSixPsd[488046] [STRING: 4800.33ef.3b0a] = INTEGER: -6.0
dB
```

**After Switchover to Secondary:**

```
docsPnmCmtsUsOfdmaRxPwrOnePtSixPsd[485742] [STRING: 4800.33ef.3b0a] = INTEGER: -6.0
dB
```

• **LCPR**

*IOSd-CLC and CDMAN LCPR:* If measurement is in progress when LCPR is triggered, some measurement samples may be lost and MeasStatus may report “Error” instead of “SampleReady”. If this occurs, set Enable to TRUE to restart the measurement.

The following is a sample output for the `show cable modem pnm us-rxpwr` command:

```
router#show cable modem pnm us-rxpwr
MAC Address      IP Address      I/F              MAC              Num    Pre  RxPwr  TimeStamp
                  IP Address      I/F              State            Avgs   Eq    (dBmv)
4800.33ef.053e 9.38.8.21      Ca1/0/0:u6      w-online (pt)   10     N    -5.7   2023-03-02
09:23:55
4800.33ef.053e 9.38.8.21      Ca1/0/0:u7      w-online (pt)   3      N    -6.0   2023-03-02
09:24:46
4800.33ef.093a 9.38.8.5       Ca1/0/0:u6      w-online (pt)   32     N    -6.0   2023-03-02
09:28:57
4800.33ef.093a 9.38.8.5       Ca1/0/0:u7      w-online (pt)   5      N    -6.0   2023-03-02
09:29:48
206a.9454.30ac 9.38.8.34      Ca1/0/2:u6      w-online (pt)   1      N    -6.2   2023-03-02
09:32:17
4800.33ef.0d1a 9.38.8.11      Ca9/0/0:u6      w-online (pt)   32     N    -6.0   2023-03-02
09:46:33
4800.33ef.0d1a 9.38.8.11      Ca9/0/0:u6      w-online (pt)   32     N    -6.0   2023-03-02
09:46:33
4800.33ef.3f12 9.38.8.27      Ca9/0/0:u6/p    w-online (pt)   1      N    ---    2023-03-02
09:41:30
4800.33ef.3f12 9.38.8.27      Ca9/0/0:u7/p    w-online (pt)   7      N    -6.0   2023-03-02
09:42:21
4800.33ef.3e86 9.38.8.20      Ca9/0/1:u6      w-online (pt)   2      N    -6.0   2023-03-02
09:48:11
4800.33ef.3e86 9.38.8.20      Ca9/0/1:u7      w-online (pt)   1      N    -6.0   2023-03-02
09:49:02
4800.33ef.0666 9.38.8.2       Ca9/0/8:u6      w-online (pt)   1      N    -6.0   2023-03-02
09:49:53
4800.33ef.0666 9.38.8.2       Ca9/0/8:u7      w-online (pt)   3      N    -5.7   2023-03-02
09:50:44
4800.33ef.3f3e 9.38.8.16      Ca9/0/9:u6      w-online (pt)   2      N    -6.0   2023-03-02
09:51:3
4800.33ef.3f3e 9.38.8.16      Ca9/0/9:u7      w-online (pt)   32     N    -3.0   2023-03-02
09:52:22
```

The following is a sample output for the `test cable pnm us-rxpwr snmp-walk all` command:

```
router#test cable pnm us-rxpwr snmp-walk all
Chan              Num          Retry
Probe            Partial
```



| ifIndex<br>Timestamp          | ID | CM-Mac<br>Mode                | Status       | Enable | Pre-Eq | Avgs | RxPwr | Cnt | Config |
|-------------------------------|----|-------------------------------|--------------|--------|--------|------|-------|-----|--------|
| 488046<br>2023-03-02 09:23:55 | 6  | 4800.33ef.053e<br>0x00 (None) | SAMPLE READY | N      | N      | 10   | -57   | 0   | Y      |
| 488046<br>2023-03-02 09:28:57 | 6  | 4800.33ef.093a<br>0x00 (None) | SAMPLE READY | N      | N      | 32   | -60   | 0   | Y      |
| 488047<br>2023-03-02 09:24:46 | 7  | 4800.33ef.053e<br>0x00 (None) | SAMPLE READY | N      | N      | 3    | -60   | 0   | Y      |
| 488047<br>2023-03-02 09:29:48 | 7  | 4800.33ef.093a<br>0x00 (None) | SAMPLE READY | N      | N      | 5    | -60   | 0   | Y      |
| 488142<br>2023-03-02 09:32:17 | 6  | 206a.9454.30ac<br>0x00 (None) | SAMPLE READY | N      | N      | 1    | -62   | 0   | Y      |
| 501870<br>2023-03-02 09:46:33 | 6  | 4800.33ef.0d1a<br>0x00 (None) | SAMPLE READY | N      | N      | 32   | -60   | 0   | Y      |
| 501870<br>2023-03-02 09:42:21 | 6  | 4800.33ef.3f12<br>0x01 (RNG)  | SAMPLE READY | N      | N      | 7    | -255  | 0   | Y      |
| 501871<br>2023-03-02 09:47:20 | 7  | 4800.33ef.0d1a<br>0x00 (None) | SAMPLE READY | N      | N      | 1    | -57   | 0   | Y      |
| 501871<br>2023-03-02 09:42:21 | 7  | 4800.33ef.3f12<br>0x01 (RNG)  | SAMPLE READY | N      | N      | 7    | -60   | 0   | Y      |
| 501918<br>2023-03-02 09:48:11 | 6  | 4800.33ef.3e86<br>0x00 (None) | SAMPLE READY | N      | N      | 2    | -255  | 0   | Y      |
| 501919<br>2023-03-02 09:49:02 | 7  | 4800.33ef.3e86<br>0x00 (None) | SAMPLE READY | N      | N      | 1    | -60   | 0   | Y      |
| 502254<br>2023-03-02 09:49:53 | 6  | 4800.33ef.0666<br>0x00 (None) | SAMPLE READY | N      | N      | 1    | -60   | 0   | Y      |
| 502255<br>2023-03-02 09:50:44 | 7  | 4800.33ef.0666<br>0x00 (None) | SAMPLE READY | N      | N      | 3    | -57   | 0   | Y      |
| 502302<br>2023-03-02 09:51:32 | 6  | 4800.33ef.3f3e<br>0x00 (None) | SAMPLE READY | N      | N      | 2    | -60   | 0   | Y      |
| 502303<br>2023-03-02 09:52:22 | 7  | 4800.33ef.3f3e<br>0x00 (None) | SAMPLE READY | N      | N      | 32   | -30   | 0   | Y      |

### SNMP Agent docsPnmCmtsUsOfdmaRxPwrEntry Walk

```
docsPnmCmtsUsOfdmaRxPwrEnable[488046] [STRING: 4800.33ef.53e] = INTEGER: false(2)
docsPnmCmtsUsOfdmaRxPwrEnable[488046] [STRING: 4800.33ef.93a] = INTEGER: false(2)
docsPnmCmtsUsOfdmaRxPwrEnable[488047] [STRING: 4800.33ef.53e] = INTEGER: false(2)
docsPnmCmtsUsOfdmaRxPwrEnable[488047] [STRING: 4800.33ef.93a] = INTEGER: false(2)
docsPnmCmtsUsOfdmaRxPwrEnable[488142] [STRING: 206a.9454.30ac] = INTEGER: false(2)
docsPnmCmtsUsOfdmaRxPwrEnable[501870] [STRING: 4800.33ef.d1a] = INTEGER: false(2)
docsPnmCmtsUsOfdmaRxPwrEnable[501871] [STRING: 4800.33ef.d1a] = INTEGER: false(2)
docsPnmCmtsUsOfdmaRxPwrEnable[501871] [STRING: 4800.33ef.3f12] = INTEGER: false(2)
docsPnmCmtsUsOfdmaRxPwrEnable[501918] [STRING: 4800.33ef.3e86] = INTEGER: false(2)
docsPnmCmtsUsOfdmaRxPwrEnable[501919] [STRING: 4800.33ef.3e86] = INTEGER: false(2)
docsPnmCmtsUsOfdmaRxPwrEnable[502254] [STRING: 4800.33ef.666] = INTEGER: false(2)
docsPnmCmtsUsOfdmaRxPwrEnable[502255] [STRING: 4800.33ef.666] = INTEGER: false(2)
docsPnmCmtsUsOfdmaRxPwrEnable[502302] [STRING: 4800.33ef.3f3e] = INTEGER: false(2)
docsPnmCmtsUsOfdmaRxPwrEnable[502303] [STRING: 4800.33ef.3f3e] = INTEGER: false(2)
docsPnmCmtsUsOfdmaRxPwrPreEq[488046] [STRING: 4800.33ef.53e] = INTEGER: false(2)
docsPnmCmtsUsOfdmaRxPwrPreEq[488046] [STRING: 4800.33ef.93a] = INTEGER: false(2)
docsPnmCmtsUsOfdmaRxPwrPreEq[488047] [STRING: 4800.33ef.53e] = INTEGER: false(2)
docsPnmCmtsUsOfdmaRxPwrPreEq[488047] [STRING: 4800.33ef.93a] = INTEGER: false(2)
docsPnmCmtsUsOfdmaRxPwrPreEq[488142] [STRING: 206a.9454.30ac] = INTEGER: false(2)
docsPnmCmtsUsOfdmaRxPwrPreEq[501870] [STRING: 4800.33ef.d1a] = INTEGER: false(2)
docsPnmCmtsUsOfdmaRxPwrPreEq[501871] [STRING: 4800.33ef.d1a] = INTEGER: false(2)
docsPnmCmtsUsOfdmaRxPwrPreEq[501871] [STRING: 4800.33ef.3f12] = INTEGER: false(2)
docsPnmCmtsUsOfdmaRxPwrPreEq[501918] [STRING: 4800.33ef.3e86] = INTEGER: false(2)
docsPnmCmtsUsOfdmaRxPwrPreEq[501919] [STRING: 4800.33ef.3e86] = INTEGER: false(2)
docsPnmCmtsUsOfdmaRxPwrPreEq[502254] [STRING: 4800.33ef.666] = INTEGER: false(2)
docsPnmCmtsUsOfdmaRxPwrPreEq[502255] [STRING: 4800.33ef.666] = INTEGER: false(2)
docsPnmCmtsUsOfdmaRxPwrPreEq[502302] [STRING: 4800.33ef.3f3e] = INTEGER: false(2)
```

```

docsPnmCmtsUsOfdmaRxPwrPreEq[502303] [STRING: 4800.33ef.3f3e] = INTEGER: false(2)
docsPnmCmtsUsOfdmaRxPwrNumAvgs[488046] [STRING: 4800.33ef.53e] = Gauge32: 10
docsPnmCmtsUsOfdmaRxPwrNumAvgs[488046] [STRING: 4800.33ef.93a] = Gauge32: 32
docsPnmCmtsUsOfdmaRxPwrNumAvgs[488047] [STRING: 4800.33ef.53e] = Gauge32: 3
docsPnmCmtsUsOfdmaRxPwrNumAvgs[488047] [STRING: 4800.33ef.93a] = Gauge32: 5
docsPnmCmtsUsOfdmaRxPwrNumAvgs[488142] [STRING: 206a.9454.30ac] = Gauge32: 1
docsPnmCmtsUsOfdmaRxPwrNumAvgs[501870] [STRING: 4800.33ef.d1a] = Gauge32: 32
docsPnmCmtsUsOfdmaRxPwrNumAvgs[501871] [STRING: 4800.33ef.d1a] = Gauge32: 1
docsPnmCmtsUsOfdmaRxPwrNumAvgs[501871] [STRING: 4800.33ef.3f12] = Gauge32: 7
docsPnmCmtsUsOfdmaRxPwrNumAvgs[501918] [STRING: 4800.33ef.3e86] = Gauge32: 2
docsPnmCmtsUsOfdmaRxPwrNumAvgs[501919] [STRING: 4800.33ef.3e86] = Gauge32: 1
docsPnmCmtsUsOfdmaRxPwrNumAvgs[502254] [STRING: 4800.33ef.666] = Gauge32: 1
docsPnmCmtsUsOfdmaRxPwrNumAvgs[502255] [STRING: 4800.33ef.666] = Gauge32: 3
docsPnmCmtsUsOfdmaRxPwrNumAvgs[502302] [STRING: 4800.33ef.3f3e] = Gauge32: 2
docsPnmCmtsUsOfdmaRxPwrNumAvgs[502303] [STRING: 4800.33ef.3f3e] = Gauge32: 32
docsPnmCmtsUsOfdmaRxPwrOnePtSixPsd[488046] [STRING: 4800.33ef.53e] = INTEGER: -5.7 dB
docsPnmCmtsUsOfdmaRxPwrOnePtSixPsd[488046] [STRING: 4800.33ef.93a] = INTEGER: -6.0 dB
docsPnmCmtsUsOfdmaRxPwrOnePtSixPsd[488046] [STRING: 4800.33ef.93a] = INTEGER: -6.0 dB
docsPnmCmtsUsOfdmaRxPwrOnePtSixPsd[488047] [STRING: 4800.33ef.93a] = INTEGER: -6.0 dB
docsPnmCmtsUsOfdmaRxPwrOnePtSixPsd[488142] [STRING: 206a.9454.30ac] = INTEGER: -6.2 dB
docsPnmCmtsUsOfdmaRxPwrOnePtSixPsd[501870] [STRING: 4800.33ef.d1a] = INTEGER: -6.0 dB
docsPnmCmtsUsOfdmaRxPwrOnePtSixPsd[501871] [STRING: 4800.33ef.d1a] = INTEGER: -5.7 dB
docsPnmCmtsUsOfdmaRxPwrOnePtSixPsd[501871] [STRING: 4800.33ef.3f12] = INTEGER: -6.0 dB
docsPnmCmtsUsOfdmaRxPwrOnePtSixPsd[501918] [STRING: 4800.33ef.3e86] = INTEGER: -6.0 dB
docsPnmCmtsUsOfdmaRxPwrOnePtSixPsd[501919] [STRING: 4800.33ef.3e86] = INTEGER: -6.0 dB
docsPnmCmtsUsOfdmaRxPwrOnePtSixPsd[502254] [STRING: 4800.33ef.666] = INTEGER: -6.0 dB
docsPnmCmtsUsOfdmaRxPwrOnePtSixPsd[502255] [STRING: 4800.33ef.666] = INTEGER: -5.7 dB
docsPnmCmtsUsOfdmaRxPwrOnePtSixPsd[502302] [STRING: 4800.33ef.3f3e] = INTEGER: -6.0 dB
docsPnmCmtsUsOfdmaRxPwrOnePtSixPsd[502303] [STRING: 4800.33ef.3f3e] = INTEGER: -3.0 dB
docsPnmCmtsUsOfdmaRxPwrMeasStatus[488046] [STRING: 4800.33ef.53e] = INTEGER: sampleReady(4)
docsPnmCmtsUsOfdmaRxPwrMeasStatus[488046] [STRING: 4800.33ef.93a] = INTEGER: sampleReady(4)
docsPnmCmtsUsOfdmaRxPwrMeasStatus[488047] [STRING: 4800.33ef.53e] = INTEGER: sampleReady(4)
docsPnmCmtsUsOfdmaRxPwrMeasStatus[488047] [STRING: 4800.33ef.93a] = INTEGER: sampleReady(4)
docsPnmCmtsUsOfdmaRxPwrMeasStatus[488142] [STRING: 206a.9454.30ac] = INTEGER: sampleReady(4)
docsPnmCmtsUsOfdmaRxPwrMeasStatus[501870] [STRING: 4800.33ef.d1a] = INTEGER: sampleReady(4)
docsPnmCmtsUsOfdmaRxPwrMeasStatus[501871] [STRING: 4800.33ef.d1a] = INTEGER: sampleReady(4)
docsPnmCmtsUsOfdmaRxPwrMeasStatus[501871] [STRING: 4800.33ef.3f12] = INTEGER: sampleReady(4)
docsPnmCmtsUsOfdmaRxPwrMeasStatus[501918] [STRING: 4800.33ef.3e86] = INTEGER: sampleReady(4)
docsPnmCmtsUsOfdmaRxPwrMeasStatus[501919] [STRING: 4800.33ef.3e86] = INTEGER: sampleReady(4)
docsPnmCmtsUsOfdmaRxPwrMeasStatus[502254] [STRING: 4800.33ef.666] = INTEGER: sampleReady(4)
docsPnmCmtsUsOfdmaRxPwrMeasStatus[502255] [STRING: 4800.33ef.666] = INTEGER: sampleReady(4)
docsPnmCmtsUsOfdmaRxPwrMeasStatus[502302] [STRING: 4800.33ef.3f3e] = INTEGER: sampleReady(4)
docsPnmCmtsUsOfdmaRxPwrMeasStatus[502303] [STRING: 4800.33ef.3f3e] = INTEGER: sampleReady(4)

```

## Clearing Modem on Proactive Network Management Upstream Channel RxPwr

Table 160: Feature History

| Feature Name                        | Release Information         | Feature Description                                                                     |
|-------------------------------------|-----------------------------|-----------------------------------------------------------------------------------------|
| New CLI support for PNM OFDMA RxPwr | Cisco IOS XE Dublin 17.12.1 | You now have new CLI support for Proactive Network Management using OFDMA RxPwr Probes. |

The following are the new CLIs supported for PNM OFDMA RxPwr:

- `router#clear cable modem pnm us-rxpwr`
- `router#clear cable modem pnm us-rxpwr upstream <0-15>`

- `router#clear cable modem pnm us-rxpwr upstream Cable <slot/0/interface> pnm us-rxpwr upstream <0-15>`
- `router#clear cable modem pnm us-rxpwr upstream Cable <mac address> pnm us-rxpwr`  
`router#clear cable modem pnm us-rxpwr upstream Cable <ip address> pnm us-rxpwr`
- `router#clear cable modem pnm us-rxpwr upstream Cable <mac address> pnm us-rxpwr upstream <0-15>`  
`router#clear cable modem pnm us-rxpwr upstream Cable <ip address> pnm us-rxpwr upstream <0-15>`

The following scenarios indicate the Proactive Network Management upstream channel RxPwr clear and show commands:

- **Clearing Modem on PNM Upstream Channel RxPwr**

To clear all the PNM upstream channel RxPwr information for cable modems, use the following `clear cable modem pnm us-rxpwr` command in the privileged EXEC mode.

```
router#clear cable modem pnm us-rxpwr
```

The following is a sample output for the `show cable modem pnm us-rxpwr` command:

```
router#show cable modem pnm ?
  us-rxpwr  PNM US RxPwr (1.6 MHz normalized) from docsPnmCmtsUsOfdmaRxPwrTable

router#show cable modem pnm us-rxpwr
MAC Address      IP Address      I/F              MAC              Num      Pre      RxPwr
TimeStamp
State           Avgs           Eq              (dBmv)
4800.33ef.3c52  9.14.0.11      Ca1/0/0:u6      w-online (pt)    1        Y        0.0
2023-09-02 10:38:14
4800.33ef.3c52  9.14.0.11      Ca1/0/0:u7      w-online (pt)    2        Y        0.7
2023-09-02 10:38:14
4800.33ef.3a72  9.14.0.45      Ca1/0/0:u6      w-online (pt)    1        Y        0.0
2023-09-02 10:40:26
4800.33ef.3a72  9.14.0.45      Ca1/0/0:u7      w-online (pt)    2        Y        0.0
2023-09-02 10:40:26
4800.33ef.3a12  9.14.0.56      Ca1/0/0:u6      w-online (pt)    1        Y        0.0
2023-09-02 10:39:31
4800.33ef.3a12  9.14.0.56      Ca1/0/0:u7      w-online (pt)    2        Y        0.0
2023-09-02 10:39:31
4800.33ef.39ce  9.14.0.51      Ca1/0/0:u6      w-online (pt)    1        Y        0.2
2023-09-02 10:40:27
4800.33ef.39ce  9.14.0.51      Ca1/0/0:u7      w-online (pt)    2        Y        0.2
2023-09-02 10:40:27
4800.33ef.3a92  9.14.0.60      Ca1/0/0:u6      w-online (pt)    1        Y        0.2
2023-09-02 10:40:28
4800.33ef.3a92  9.14.0.60      Ca1/0/0:u7      w-online (pt)    2        Y        0.2
2023-09-02 10:40:28
4800.33ef.0baa  9.14.0.72      Ca1/0/0:u6      w-online (pt)    1        Y        0.5
2023-09-02 10:38:14
4800.33ef.0baa  9.14.0.72      Ca1/0/0:u7      w-online (pt)    2        Y        -0.2
2023-09-02 10:38:14
4800.33ef.3aa2  9.14.0.55      Ca1/0/0:u6      w-online (pt)    1        Y        0.2
2023-09-02 10:38:20
4800.33ef.3aa2  9.14.0.55      Ca1/0/0:u7      w-online (pt)    2        Y        0.2
2023-09-02 10:38:20
4800.33ee.f732  9.14.0.73      Ca1/0/0:u6      w-online (pt)    1        Y        0.0
```

```

2023-09-02 10:38:13
4800.33ee.f732 9.14.0.73      Cal/0/0:u7      w-online(pt)    2      Y      0.0
2023-09-02 10:38:13
4800.33ef.060a 9.14.0.70      Cal/0/0:u6      w-online(pt)    1      Y      1.0
2023-09-03 08:57:41
4800.33ef.060a 9.14.0.70      Cal/0/0:u7      w-online(pt)    8      Y      0.2
2023-09-02 10:38:13
0cb9.37d8.00c4 9.14.0.36      Cal/0/0:u6      w-online(pt)    1      Y      -t-
2023-09-02 10:40:29
0cb9.37d8.00c4 9.14.0.36      Cal/0/0:u7      w-online(pt)    3      Y      -t-
2023-09-02 10:40:29
4800.33ef.38ae 9.14.0.66      Cal/0/0:u6      w-online(pt)    1      Y      0.2
2023-09-02 10:39:30
4800.33ef.38ae 9.14.0.66      Cal/0/0:u7      w-online(pt)    2      Y      0.2
2023-09-02 10:39:30
4800.33ef.394e 9.14.0.44      Cal/0/0:u6      w-online(pt)    1      Y      0.0
2023-09-02 10:40:25
4800.33ef.394e 9.14.0.44      Cal/0/0:u7      w-online(pt)    2      Y      0.0
2023-09-02 10:40:25
4800.33ef.3a9a 9.14.0.35      Cal/0/0:u6      w-online(pt)    1      Y      0.0
2023-09-02 10:39:37
4800.33ef.3a9a 9.14.0.35      Cal/0/0:u7      w-online(pt)    2      Y      0.0
2023-09-02 10:39:37
4800.33ef.38c2 9.14.0.38      Cal/0/0:u6      w-online(pt)    1      Y      0.2
2023-09-02 10:39:41
4800.33ef.38c2 9.14.0.38      Cal/0/0:u7      w-online(pt)    2      Y      0.2
2023-09-02 10:39:41
4800.33ef.3a82 9.14.0.54      Cal/0/0:u6      w-online(pt)    1      Y      0.2
2023-09-02 10:39:41
4800.33ef.3a82 9.14.0.54      Cal/0/0:u7      w-online(pt)    2      Y      0.0
2023-09-02 10:39:41
4800.33ef.3972 9.14.0.53      Cal/0/0:u6      w-online(pt)    1      Y      0.2
2023-09-02 10:38:24
4800.33ef.3972 9.14.0.53      Cal/0/0:u7      w-online(pt)    2      Y      0.0
2023-09-02 10:38:24
d4b9.2f6e.f4b8 9.14.0.75      Cal/0/1:u6      w-online(pt)    2      Y      0.2
2023-09-02 10:40:30
d4b9.2f6e.f4b8 9.14.0.75      Cal/0/1:u7      w-online(pt)    3      Y      0.2
2023-09-02 10:40:30
4800.33ef.06ca 9.14.0.71      Cal/0/1:u6      w-online(pt)    2      Y      0.0
2023-09-02 10:40:31
4800.33ef.06ca 9.14.0.71      Cal/0/1:u7      w-online(pt)    3      Y      0.2
2023-09-02 10:40:31
4800.33ea.716a 9.14.0.74      Cal/0/1:u6      w-online(pt)    2      Y      0.0
2023-09-02 10:40:30
4800.33ea.716a 9.14.0.74      Cal/0/1:u7      w-online(pt)    3      Y      0.0
2023-09-02 10:40:30
4800.33ef.0ac2 9.14.0.34      Cal/0/1:u6      w-online(pt)    2      Y      -0.2
2023-09-02 10:40:31
4800.33ef.0ac2 9.14.0.34      Cal/0/1:u7      w-online(pt)    3      Y      0.0
2023-09-02 10:40:31

```

i = probe inactive

n = very low power or no energy

q = equalization coefficient config mismatch with probe pre-equalization setting

t = probe response timeout condition, no probe response received

x = probe not sent

#### • Clearing Modem on PNM Upstream Channel RxPwr on a Specific OFDMA channel

To clear all the PNM upstream channel RxPwr information for cable modems on a specific OFDMA channel, use the following **clear cable modem pnm us-rxpwr** command in the privileged EXEC mode.

```
router#clear cable modem pnm us-rxpwr upstream <0-15>
```

### • Clearing Modem on PNM Upstream Channel RxPwr on a Specific Cable Interface

To clear all the PNM upstream channel RxPwr information for cable modems on a specific cable interface on a specific OFDMA channel, use the following **clear cable modem pnm us-rxpwr Cable** command in the privileged EXEC mode.

```
router#clear cable modem pnm us-rxpwr upstream Cable <slot/0/interface> pnm us-rxpwr upstream <0-15>
```

The following is a sample output for the **show clear cable modem pnm us-rxpwr Cable** command:

```
router#show clear cable modem C1/0/0 pnm us-rxpwr ?
|      Output modifiers
|      <cr> <cr>

router#show clear cable modem C1/0/0 pnm us-rxpwr
MAC Address      IP Address      I/F            MAC              Num      Pre      RxPwr
TimeStamp
State            Avgs            Eq              (dBmv)
4800.33ef.3c52 9.14.0.11      Ca1/0/0:u6     w-online (pt)    1        Y        0.0
2023-09-02 10:38:14
4800.33ef.3c52 9.14.0.11      Ca1/0/0:u7     w-online (pt)    2        Y        0.7
2023-09-02 10:38:14
4800.33ef.3a72 9.14.0.45      Ca1/0/0:u6     w-online (pt)    1        Y        0.0
2023-09-02 10:40:26
4800.33ef.3a72 9.14.0.45      Ca1/0/0:u7     w-online (pt)    2        Y        0.0
2023-09-02 10:40:26
4800.33ef.3a12 9.14.0.56      Ca1/0/0:u6     w-online (pt)    1        Y        0.0
2023-09-02 10:39:31
4800.33ef.3a12 9.14.0.56      Ca1/0/0:u7     w-online (pt)    2        Y        0.0
2023-09-02 10:39:31
4800.33ef.39ce 9.14.0.51      Ca1/0/0:u6     w-online (pt)    1        Y        0.2
2023-09-02 10:40:27
4800.33ef.39ce 9.14.0.51      Ca1/0/0:u7     w-online (pt)    2        Y        0.2
2023-09-02 10:40:27
4800.33ef.3a92 9.14.0.60      Ca1/0/0:u6     w-online (pt)    1        Y        0.2
2023-09-02 10:40:28
4800.33ef.3a92 9.14.0.60      Ca1/0/0:u7     w-online (pt)    2        Y        0.2
2023-09-02 10:40:28
4800.33ef.0baa 9.14.0.72      Ca1/0/0:u6     w-online (pt)    1        Y        0.5
2023-09-02 10:38:14
4800.33ef.0baa 9.14.0.72      Ca1/0/0:u7     w-online (pt)    2        Y        -0.2
2023-09-02 10:38:14
4800.33ef.3aa2 9.14.0.55      Ca1/0/0:u6     w-online (pt)    1        Y        0.2
2023-09-02 10:38:20
4800.33ef.3aa2 9.14.0.55      Ca1/0/0:u7     w-online (pt)    2        Y        0.2
2023-09-02 10:38:20
4800.33ee.f732 9.14.0.73      Ca1/0/0:u6     w-online (pt)    1        Y        0.0
2023-09-02 10:38:13
4800.33ee.f732 9.14.0.73      Ca1/0/0:u7     w-online (pt)    2        Y        0.0
2023-09-02 10:38:13
4800.33ef.060a 9.14.0.70      Ca1/0/0:u6     w-online (pt)    1        Y        1.0
2023-09-03 08:57:41
4800.33ef.060a 9.14.0.70      Ca1/0/0:u7     w-online (pt)    8        Y        0.2
2023-09-02 10:38:13
0cb9.37d8.00c4 9.14.0.36      Ca1/0/0:u6     w-online (pt)    1        Y        -t-
2023-09-02 10:40:29
0cb9.37d8.00c4 9.14.0.36      Ca1/0/0:u7     w-online (pt)    3        Y        -t-
2023-09-02 10:40:29
4800.33ef.38ae 9.14.0.66      Ca1/0/0:u6     w-online (pt)    1        Y        0.2
2023-09-02 10:39:30
4800.33ef.38ae 9.14.0.66      Ca1/0/0:u7     w-online (pt)    2        Y        0.2
```

```

2023-09-02 10:39:30
4800.33ef.394e 9.14.0.44      Ca1/0/0:u6      w-online(pt)    1      Y      0.0
2023-09-02 10:40:25
4800.33ef.394e 9.14.0.44      Ca1/0/0:u7      w-online(pt)    2      Y      0.0
2023-09-02 10:40:25
4800.33ef.3a9a 9.14.0.35      Ca1/0/0:u6      w-online(pt)    1      Y      0.0
2023-09-02 10:39:37
4800.33ef.3a9a 9.14.0.35      Ca1/0/0:u7      w-online(pt)    2      Y      0.0
2023-09-02 10:39:37
4800.33ef.38c2 9.14.0.38      Ca1/0/0:u6      w-online(pt)    1      Y      0.2
2023-09-02 10:39:41
4800.33ef.38c2 9.14.0.38      Ca1/0/0:u7      w-online(pt)    2      Y      0.2
2023-09-02 10:39:41
4800.33ef.3a82 9.14.0.54      Ca1/0/0:u6      w-online(pt)    1      Y      0.2
2023-09-02 10:39:41
4800.33ef.3a82 9.14.0.54      Ca1/0/0:u7      w-online(pt)    2      Y      0.0
2023-09-02 10:39:41
4800.33ef.3972 9.14.0.53      Ca1/0/0:u6      w-online(pt)    1      Y      0.2
2023-09-02 10:38:24
4800.33ef.3972 9.14.0.53      Ca1/0/0:u7      w-online(pt)    2      Y      0.0
2023-09-02 10:38:24

```

```

i = probe inactive
n = very low power or no energy
q = equalization coefficient config mismatch with probe pre-equalization setting
t = probe response timeout condition, no probe response received
x = probe not sent

```

State

Avgs Eq (dBmv)

#### • Clearing Modem on PNM Upstream Channel RxPwr on a Specific Cable Modem

To clear the PNM upstream channel RxPwr information for a specific cable modem, use the following **clear cable modem pnm us-rxpwr [H.H.H or A.B.C.D] upstream** command in the privileged EXEC mode.

Where [H.H.H] is a specific modem's unique MAC address and [A.B.C.D] is a specific modem's assigned IP address.

```
router#clear cable modem pnm us-rxpwr upstream Cable H.H.H pnm us-rxpwr
```

```
router#clear cable modem pnm us-rxpwr upstream Cable A.B.C.D pnm us-rxpwr
```

The following is a sample output for the **show cable modem mac address pnm us-rxpwr** command:

```
router#show cable modem 4800.33ef.060a pnm us-rxpwr ?
```

```

|      Output modifiers
<cr> <cr>

```

```
router#show cable modem 4800.33ef.060a pnm us-rxpwr
```

| MAC Address         | IP Address | I/F        | MAC          | Num  | Pre | RxPwr  |
|---------------------|------------|------------|--------------|------|-----|--------|
| 4800.33ef.060a      | 9.14.0.70  | Ca1/0/0:u6 | State        | Avgs | Eq  | (dBmv) |
| 2023-09-03 08:57:41 |            |            | w-online(pt) | 1    | Y   | 1.0    |
| 4800.33ef.060a      | 9.14.0.70  | Ca1/0/0:u7 | w-online(pt) | 8    | Y   | 0.2    |
| 2023-09-02 10:38:13 |            |            |              |      |     |        |

```

i = probe inactive
n = very low power or no energy
q = equalization coefficient config mismatch with probe pre-equalization setting
t = probe response timeout condition, no probe response received
x = probe not sent

```

### • Clearing Modem on PNM Upstream Channel RxPwr on a Specific Cable Modem on a Specific Upstream Channel OFDMA Channel

To clear the PNM upstream channel RxPwr information for a specific cable modem on a specific upstream channel OFDMA channel, use the following `clear cable modem pnm us-rxpwr [H.H.H or A.B.C.D]` command in privileged EXEC mode.

Where [H.H.H] is a specific modem's unique MAC address and [A.B.C.D] is a specific modem's assigned IP address.

```
router#clear cable modem pnm us-rxpwr upstream Cable H.H.H pnm us-rxpwr upstream <0-15>
router#clear cable modem pnm us-rxpwr upstream Cable A.B.C.D pnm us-rxpwr upstream
<0-15>
```

## Verifying the Proactive Network Management Using OFDMA RxPwr Probes

You can verify the Proactive Network Management using OFDMA RxPwr Probes under the following scenarios:

### • Verifying the PNM using Specific Status Reason Codes

The following example shows the PNM RxPwr Probe to the modem 0cb9.37d8.00c4 failure due to a *-t-* timeout because the modem did not respond to the PNM RxPwr Probe.

```
router#scm 0cb9.37d8.00c4 pnm us
router#show cable modem 0cb9.37d8.00c4 pnm us-rxpwr
MAC Address      IP Address      I/F              MAC              Num      Pre      RxPwr
TimeStamp
0cb9.37d8.00c4  9.14.0.36      Ca1/0/0:u6      w-online (pt)    1        Y        -t-
2023-09-02 10:40:29
0cb9.37d8.00c4  9.14.0.36      Ca1/0/0:u7      w-online (pt)    3        Y        -t-
2023-09-02 10:40:29
```

where,

- *i*—indicates that the probe is inactive
- *n*—very low power or no energy
- *q*—equalization coefficient configuration mismatch with probe pre-equalization setting
- *t*—probe response timeout condition, no probe response received
- *x*—probe not sent

### • Verifying the PNM using Upstream Channel Partial-Service Mode (RNG)

If the OFDMA upstream channel of a modem is in a partial-service condition due to RNG mode, then the PNM RxPwr Probes are not sent to the modem and will be dropped on the iCMTS.

The **I/F** column indicates the upstream channel partial-service condition with a */p* following the interface name string. And, the RxPwr column has the specific status reason code *-x-* indicating the PNM RxPwr probe request was dropped. There is a possibility that the OFDMA upstream channel entered the partial-service condition after the PNM RxPwr Probe was received from the modem. In this case, the **I/F** column indicates the upstream channel partial-service condition with a */p* following the interface name string. And, the RxPwr column has the specific status reason code *-i-* to indicate the PNM RxPwr Probe is in the inactive state.

The following example shows the PNM RxPwr Probe to the OFDMA upstream channel in a partial-service condition state due to RNG mode and denotes **-t-** indicating the PNM RxPwr Probe in inactive state and **/p** the interface name string and **-x** indicating the probe request dropped.

```
router#show cable modem 4800.33ef.060a pnm us-rxpwr
```

| MAC Address<br>TimeStamp              | IP Address | I/F        | MAC | State         | Num | Pre | RxPwr<br>(dBmv) |
|---------------------------------------|------------|------------|-----|---------------|-----|-----|-----------------|
| 4800.33ef.060a<br>2023-09-02 10:41:12 | 9.14.0.70  | Ca1/0/0:u6 | /p  | w-online (pt) | 1   | Y   | <b>-x-</b>      |
| 4800.33ef.060a<br>2023-09-02 10:38:13 | 9.14.0.70  | Ca1/0/0:u7 |     | w-online (pt) | 8   | Y   | 0.2             |

```
router#show cable modem 4800.33ef.060a pnm us-rxpwr
```

| MAC Address<br>TimeStamp              | IP Address | I/F        | MAC | State         | Num | Pre | RxPwr<br>(dBmv) |
|---------------------------------------|------------|------------|-----|---------------|-----|-----|-----------------|
| 4800.33ef.060a<br>2023-09-02 10:44:02 | 9.14.0.70  | Ca1/0/0:u6 | /p  | w-online (pt) | 1   | Y   | <b>-i-</b>      |
| 4800.33ef.060a<br>2023-09-02 10:38:13 | 9.14.0.70  | Ca1/0/0:u7 |     | w-online (pt) | 8   | Y   | 0.2             |

#### • Verifying the PNM using Equalization Coefficient Configuration Mismatch

If there is a mismatch between the PNM RxPwr Probe *DocsPnmCmtsOfdmaRxPwrEntry's docsPnmCmtsOfdmaRxPwrPreEq* (Pre-Equalization) setting and the iCMTS's Upstream Controller configuration or the RPHY's Upstream Controller Profile configuration of the OFDMA channel's equalization-coefficient, then the RxPwr column has the specific status reason code **-q-** to indicate the PNM RxPwr Probe equalization coefficient configuration mismatch case.

The following example shows the OFDMA channel's equalization-coefficient denoting **-q-** indicating the PNM RxPwr Probe equalization coefficient configuration mismatch case.

```
router#show cable modem 4800.33ef.060a pnm us-rxpwr
```

| MAC Address<br>TimeStamp              | IP Address | I/F        | MAC | State         | Num | Pre | RxPwr<br>(dBmv) |
|---------------------------------------|------------|------------|-----|---------------|-----|-----|-----------------|
| 4800.33ef.060a<br>2023-09-03 08:46:20 | 9.14.0.70  | Ca1/0/0:u6 |     | w-online (pt) | 1   | Y   | <b>-q-</b>      |
| 4800.33ef.060a<br>2023-09-02 10:38:13 | 9.14.0.70  | Ca1/0/0:u7 |     | w-online (pt) | 8   | Y   | 0.2             |

#### • Verifying the Probe Timeout

If a PNM RxPwr Probe request to a specific modem on a specific OFDMA upstream channel is not answered by the modem within 60 seconds, then the RxPwr column has the specific status reason code **-t-** to indicate that the PNM RxPwr Probe response timeout condition, no probe response received case. During the time period that the iCMTS waits for the modem's PNM RxPwr response, the RxPwr column has the specific status reason code **---** to indicate that the PNM RxPwr Probe is in a *Busy* condition case.

The following example shows the OFDMA channel's equalization-coefficient denoting the PNM RxPwr Probe Busy condition case:

```
router#show cable modem 4800.33ef.060a pnm us-rxpwr
```

| MAC Address<br>TimeStamp              | IP Address | I/F        | MAC | State         | Num | Pre | RxPwr<br>(dBmv) |
|---------------------------------------|------------|------------|-----|---------------|-----|-----|-----------------|
| 4800.33ef.060a<br>2023-09-02 21:56:05 | 9.14.0.70  | Ca1/0/0:u6 |     | w-online (pt) | 1   | Y   | <b>---</b>      |



```
4800.33ef.060a 9.14.0.70      Ca1/0/0:u7      w-online (pt)   8      Y      0.2
2023-09-02 10:38:13
```

Eventually, the sample output displays the timeout condition:

```
router#show cable modem 4800.33ef.060a pnm us-rxpwr
MAC Address      IP Address      I/F      MAC      Num      Pre      RxPwr
TimeStamp
State      Avgs      Eq      (dBmv)
4800.33ef.060a 9.14.0.70      Ca1/0/0:u6      w-online (pt)   1      Y      -t-
2023-09-02 21:56:05
4800.33ef.060a 9.14.0.70      Ca1/0/0:u7      w-online (pt)   8      Y      0.2
2023-09-02 10:38:13
```

## Troubleshooting Proactive Network Management Issues

The Upstream Triggered Spectrum Capture issues, their possible causes, and resolution are listed.

- Capture configuration failure:
  - Ensure that the ifindex that is used is correct and the port is configured correctly under RPD for RPHY.
  - Ensure that the capture configuration entry was created properly and the client/snmp owns the capture port using MIB commands.
  - Ensure that the parameters being configured are supported and within the valid range.
  - Enable **debug cable pnm utscom-error** to check for any errors.
- Capture control or initiate test failure:
  - Ensure that the capture configuration is created and configured correctly by the client using MIB commands.
  - Verify that the capture configuration entry status is active using MIB commands.
  - The total number of captures is below the enforced limit.
  - Ensure that no other tests are already running on the port using MIB commands.
  - Ensure that only one port per RPD is running the test.
- TFTP file transfer failure:
  - Ensure that the BDT TFTP information is configured correctly on the CMTS.
  - Ensure that the TFTP server is reachable and the destination location is writable.
  - Ensure that the container is in running state using show commands.
  - Ensure that the PNM TFTP process is active and running on the `guestshell` container and the TFTP server IP is reachable from the `guestshell` container.
  - Ensure that the capture tests are running correctly and with the CLC show, CLI show, files are being generated.
  - Check dtrack to ensure that the punt path is working and packets are being sent to the container.

- Use the PNM debug and the container statistics/log file to check for any errors.
- PNM packets are not reaching guestshell:
  - Check dtrack. All PNM packets should be punted with punt-cause Service-Engine.
  - Run bash in guestshell, and check **RX packets** in ifconfig.
  - Run bash in guestshell, and use tcpdump to check if the PNM packets are arriving.
  - PNM packets from CLC use the Global Routing Table, and there is no mechanism to allow these packets to use anything other than GRT. If the guestshell and VirtualPortGroup are in the VRF, you can add a static route which directs the PNM packets into VRF. For example:

The current configuration is:

```
!
ip vrf vrf_pnm
  rd yyy:zzz
  route-target export yyy:w
  route-target import yyy:w
!
interface VirtualPortGroup0
  ip vrf forwarding vrf_pnm
  ip address P.Q.R.253 255.255.255.252
  no mop enabled
  no mop sysid
!
app-hosting appid guestshell
  app-vnic gateway0 virtualportgroup 0 guest-interface 0
  guest-ipaddress P.Q.R.254 netmask 255.255.255.252
  app-default-gateway P.Q.R.253 guest-interface 0
!
```

Add a static route:

```
(config)# ip route P.Q.R.254 255.255.255.255 VirtualPortGroup0
```

## Upstream External PMA

*Table 161: Feature History*

| Feature Name                       | Release Information          | Feature Description                                                                                                                                                                                   |
|------------------------------------|------------------------------|-------------------------------------------------------------------------------------------------------------------------------------------------------------------------------------------------------|
| Kafka support for multiple brokers | Cisco IOS XE Dublin 17.12.1z | Starting from this release, Kafka broker cluster now provides support for monitoring the connection status of up to a maximum of two brokers. Each broker connection can be maintained independently. |

| Feature Name                                | Release Information          | Feature Description                                                                                                                                                                                                                                                                                                                                                                                                                                                                                        |
|---------------------------------------------|------------------------------|------------------------------------------------------------------------------------------------------------------------------------------------------------------------------------------------------------------------------------------------------------------------------------------------------------------------------------------------------------------------------------------------------------------------------------------------------------------------------------------------------------|
| Kafka support for OFDMA channel information | Cisco IOS XE Dublin 17.12.1z | The cBR-8 routers now include a new telemetry event, OFDMA-Status, which serves to identify channel configurations and monitor the upstream status of channels.                                                                                                                                                                                                                                                                                                                                            |
| Upstream External PMA with Kafka            | Cisco IOS XE Dublin 17.12.1y | In this release, Upstream External PMA is supported with Kafka. cBR8-routers publish US RxMER data automatically based on OFDMA <b>prof-mgmt</b> configured interval. The Publish rate can be down-sampled using the <b>cable telemetry topic us-rxmer publish-rate</b> command.<br><br>In this release, RxMer probe averaging is supported.                                                                                                                                                               |
| Upstream External PMA with SNMP/TFTP        | Cisco IOS XE Dublin 17.12.1x | In previous releases, the operator would need to provision static OFDMA modulation profile definitions that addressed all known and anticipated plant conditions, both static and dynamic.<br><br>In this release, the operator has the ability to allow an external Artificial Intelligence (AI) to both tune the profiles for specific plants and dynamically change modulation definitions to address dynamic plant conditions. The AI resides within an external Profile Management Application (PMA). |

In previous releases, the operator would need to provision static OFDMA modulation profile definitions that addressed all known and anticipated plant conditions, both static and dynamic. This required the operator to perform manual tuning and it did not fully optimize profile definitions for specific dynamic plant conditions.

Starting with Cisco IOS XE Dublin 17.12.1x, the operator has the ability to allow an external AI to both tune the profiles for specific plants and dynamically change modulation definitions to address dynamic plant conditions. The AI resides within an external Profile Management Application (PMA).

#### Upstream External PMA with SNMP/TFTP

Starting with Cisco IOS XE Dublin 17.12.1x, US-PMA is supported with SNMP/TFTP. PMA uses the SNMP PNM MIB to probe the OFDMA channel and generate OSSI RxMER formatted files to a TFTP server.

Use the **cable upstream ofdma-prof-mgmt snmp pnm-rxmer-intercept** command to generate a TFTP file from the current profile-mgmt RxMER data. When enabled, SNMP PNM probe requests returns the existing channel RxMER data, avoiding additional probe overhead on the channel.

The PMA retrieves RxMER data from the TFTP server to generate OFDMA mini-slot bit-loading (MSBL) overrides. The PMA sets MSBL overrides using Exec CLI commands and commits.

### Operation Method

The following steps describe the Operation Method for configuring PMA.

1. Configure the cBR-8 router with baseline OFDMA channel profiles.
2. The cBR-8 router US prof-mgmt performs RxMER probing and IUC selection.
3. PMA triggers RxMER probe via SNMP MIB - docsPnmCmtsUsOfdmaRxMerTable.
4. The cBR-8 router initiates RxMER probe request (or optionally retrieves the latest RxMER data from profile selection).
5. The cBR-8 router's TFTP RxMER data is sent to the destination server.
6. PMA back end reads RxMER data from files on the TFTP server.
7. PMA computes the optimal OFDMA channel profile MSBL overrides.
8. PMA sets MSBL overrides in cBR-8 using Exec CLI commands.
9. The cBR-8 router updates DOCSIS UCD MMMs to communicate new profile content to RPDs and modems.
10. The cBR-8 router profile-mgmt performs RxMER probing and IUC selection (ongoing) to move modems to new optimal IUC profiles.

### Upstream External PMA with Kafka

Starting with Cisco IOS XE Dublin 17.12.1y, US-PMA is supported with Apache Kafka. Apache Kafka is an open-source distributed event streaming platform. Kafka supports a producer/broker/consumer model where the cBR-8 acts as the producer and the external PMA is the consumer. A Kafka broker (or broker cluster) runs on an external server in the network and provides reception of events that are published from the cBR-8, persistent storage for events and delivery of event data to consumers.

The cBR-8 publishes US RxMER events on Kafka automatically based on the OFDMA profile-mgmt configured interval. The event publish rate can be down-sampled using the **publish-rate** configuration option. The PMA Kafka consumer receives US RxMER events to generate OFDMA MSBL overrides. PMA sets MSBL overrides with Exec CLIs and commits.

The cBR-8 publishes OFDMA-Status events on Kafka at boot-up and after a channel configuration or a state change happens. PMA consumer uses OFDMA-status events to identify channel configuration and track the channel upstream status.

The following example shows how to configure upstream external PMA with Kafka.

1. Configure US-PMA feature.
 

```
cable upstream pma external
```
2. Configure the Cable Telemetry Services.

```
cable telemetry enable
```

3. Configure the US-RxMER Topic with event publish rate.

```
cable telemetry topic us-rxmer publish-rate 1
```

4. Configure the OFDMA-Status Topic.

```
cable telemetry topic ofdma-status
```

5. Configure the Kafka Broker

```
cable telemetry broker kafka-broker
  bootstrap-servers 1.2.2.251
  topic us-rxmer
  topic ofdma-status
cable telemetry broker kafka-broker-2
  bootstrap-servers 1.2.2.252
  topic us-rxmer
```

### Kafka Broker Connection

The Kafka broker must be specified by IPv4 address using the **bootstrap-servers** command:

```
cable telemetry broker kafka-broker
  bootstrap-servers 1.2.0.150:9092
```

The following Kafka Broker configuration is required in **server.properties** when starting the server.

```
[root@kafka-server config]#bin/kafka-server-start.sh config/server.properties
# Listener name, hostname and port the broker will advertise to clients.
# If not set, it uses the value for "listeners".
advertised.listeners=PLAINTEXT://1.2.0.150:9092
```

### Kafka US-RxMER Telemetry Event

cBR-8 Telemetry events are published on Kafka using Google Protocol Buffer (GPB) message format. GPB is a language-neutral, platform-neutral, extensible mechanism for serializing structured data.

Here are the details of the Cisco Telemetry GPB file:

- Package: **cisco\_cable\_telemetry**

- Message: **PmaUsRxMer**

Sub-messages

- **OssiPnmUsRxMer**

- **PmaUsRxMerHdr**

Here is a sample GPB **.proto** file for the US-RxMER event:

```
/*
 *
 * file: cisco_cable_telemetry.proto
 *
 * Upstream MER Telemetry and channel stats, Google Proto Buff format
 *
 * Copyright (c) 2022-2024 by Cisco Systems, Inc.
 * All rights reserved.
 */
```

```

syntax = "proto3";

package cisco_cable_telemetry;

message OssiPnmUsRxMer {
  uint32 file_type           = 1;
  uint32 major_ver          = 2;
  uint32 minor_ver          = 3;
  uint32 capture_time       = 4;
  uint32 if_index           = 5;
  string ccap_id            = 6;
  bytes rpd_id              = 7;
  uint32 rpd_port_num       = 8;
  bytes cm_mac_addr         = 9;
  uint32 number_of_averages = 10;
  uint32 preeq_on_off       = 11;
  uint32 subcarrier_zero_center_freq = 12;
  uint32 first_active_subcarrier_index = 13;
  uint32 subcarrier_spacing_in_khz = 14;
  uint32 rx_mer_byte_len    = 15;
  bytes rx_mer_data         = 16;
}

message PmaUsRxMerHdr {
  uint32 version           = 1;
  uint32 slot              = 2;
  uint32 ctrlr             = 3;
  uint32 us_channel        = 4;
  uint32 mac_domain        = 5;
  uint32 ucid              = 6;
  uint32 ucd_cc            = 7;
  uint64 total_cws         = 8;
  uint64 good_cws          = 9;
  uint64 corr_cws          = 10;
  uint64 uncorr_cws        = 11;
}

message PmaUsRxMer {
  PmaUsRxMerHdr header = 1;
  OssiPnmUsRxMer ossi  = 2;
}

```

Here is a sample GBP .proto file for the OFDMA-Status event:

```

/*
 *
 * file: cisco_docsis_ofdma_status.proto
 *
 * DOCSIS 3.1 OFDMA channel config and status, Google Proto Buff format
 *
 * Copyright (c) 2023 by Cisco Systems, Inc.
 * All rights reserved.
 */

syntax = "proto3";

package cisco_docsis_ofdma_channel;

/* OFDMA channel state. */
enum OfdmaState {
  OFDMA_STATE_UNSPECIFIED = 0; // reject stage and commit
  OFDMA_STATE_ADMIN_DOWN = 1; // accept stage , reject commit
  OFDMA_STATE_ADMIN_UP_OPER_DOWN = 2; // accept stage and commit
}

```

```

    OFDMA_STATE_OPER_UP = 3;
}

/* LCHA status */
enum LchaStatus {
    LCHA_STATUS_UNSPECIFIED = 0;
    LCHA_STATUS_PRIMARY_ACTIVE = 1;
    LCHA_STATUS_SECONDARY_ACTIVE = 2;
}

/* See MULPI Spec table "Channel TLV Parameters" TLV 28 */
enum SubcarrierSpacing {
    SC_SPACING_UNSPECIFIED = 0;
    SC_SPACING_25KHZ = 1;
    SC_SPACING_50KHZ = 2;
}

message SubcarrierBand {
    uint32 sc_start = 1;
    uint32 sc_end = 2;
}

message MinislotGroup {
    uint32 sc_start = 1;
    uint32 minislot_start = 2;
    // Modulation bitload range: {0-12}
    // Ref: Cablelabs MULPI spec UCD TLV 21 Table:
    uint32 modulation_bitload = 3;
    // Pilot Pattern Range: {1-14}
    // Ref: Cablelabs MULPI spec table
    uint32 pilot_pattern = 4;
    uint32 consecutive_minislots = 5;
}

message IucBurstProfile {
    uint32 iuc = 1;
    repeated MinislotGroup minislot_groups = 2;
}

message PmaOfdmaStatus {
    uint32 major_ver = 1;
    uint32 minor_ver = 2;
    uint32 reporting_time = 3;
    uint32 if_index = 4;
    string ccap_id = 5;
    uint32 slot = 6; // primary slot
    uint32 ctrlr = 7;
    uint32 us_channel = 8;
    uint32 mac_domain = 9;
    uint32 ucid = 10; // 1-based ucid
    OfdmaState ofdma_state = 11;
    LchaStatus lcha_status = 12;
    SubcarrierSpacing sc_spacing = 13;
    uint32 sc_0_center_freq_hz = 14;

    repeated SubcarrierBand sc_exclusion_bands = 15;
    repeated SubcarrierBand sc_unused_bands = 16;
    repeated IucBurstProfile base_iuc_burst_profiles = 17;
    repeated IucBurstProfile current_iuc_burst_profiles = 18;
}

```

### US-PMA with Kafka Telemetry Summary

- cBR-8 publishes US RxMER data automatically based on OFDMA prof-mgmt configured interval. Publish rate can be down-sampled using the configured **publish-rate** option.

- PMA consumer receives US RxMER data to generate OFDMA MSBL overrides.
- PMA sets MSBL overrides with Exec CLIs and commits.

### US-PMA Configuration Commands

Upstream PMA configuration commands can be grouped into three areas:

- PMA configuration control for MSBL overrides
- PMA configuration when using SNMP/TFTP
- PMA configuration when using Kafka

**Table 162: US-PMA Configuration Commands for MSBL Overrides**

| Command                                                                     | Description                                                                                                                                                                                                                                                                                                                                                                                                                                                                                                                                                                                                                                                                                                                                                                                                                                                                                                                                                                                                |
|-----------------------------------------------------------------------------|------------------------------------------------------------------------------------------------------------------------------------------------------------------------------------------------------------------------------------------------------------------------------------------------------------------------------------------------------------------------------------------------------------------------------------------------------------------------------------------------------------------------------------------------------------------------------------------------------------------------------------------------------------------------------------------------------------------------------------------------------------------------------------------------------------------------------------------------------------------------------------------------------------------------------------------------------------------------------------------------------------|
| <b>[no] cable pma upstream external</b>                                     | <p>Global level config to enable PMA control.</p> <p>The default is <b>no cable pma upstream external</b></p> <p>Enables MSBL override Exec CLI support.</p> <p>On <b>no cable pma upstream external all</b>, PMA band overrides are removed.</p>                                                                                                                                                                                                                                                                                                                                                                                                                                                                                                                                                                                                                                                                                                                                                          |
| <b>[no] cable pma upstream commit-action</b><br><b>[recalculate   wait]</b> | <p>Configures an action for the cBR-8 to take when the PMA commits the MSBL overrides for an OFDMA channel.</p> <p><b>Recalculate</b> – Causes the cBR-8 to recalculate the recommended IUC for each modem using the OFDMA channel with the newly committed MSBL override data IUCs. Modems that have a new recommended IUC are automatically activated on the new IUC immediately using a DBC-REQ message. The OFDMA prof-mgmt interval is unaffected by this DBC-REQ.</p> <p><b>Wait</b> - Causes the cBR-8 to wait until the next OFDMA prog-mgmt interval, and therefore new RxMER data, before recalculating the recommended IUC for each modem using the OFDMA channel with the recently committed MSBL override data IUCs.</p> <p>Default is <b>cable pma upstream commit-action recalculate</b>. This may result in an immediate change to the modem's active data IUC. Upstream profile management will again reevaluate the recommended IUC at the next regular profile management interval.</p> |



| Command                                                          | Description                                                                                                                                                                                                                                                                                                                                                                                                                                                                                                                                                                                                                                                                                                                                                                                                                                                                                                                              |
|------------------------------------------------------------------|------------------------------------------------------------------------------------------------------------------------------------------------------------------------------------------------------------------------------------------------------------------------------------------------------------------------------------------------------------------------------------------------------------------------------------------------------------------------------------------------------------------------------------------------------------------------------------------------------------------------------------------------------------------------------------------------------------------------------------------------------------------------------------------------------------------------------------------------------------------------------------------------------------------------------------------|
| <b>[no] cable pma upstream clear-action [recalculate   wait]</b> | <p>Configures an action for the cBR-8 to take when the PMA clears the MSBL overrides for an OFDMA channel.</p> <p><b>Recalculate</b> – causes the cBR-8 to recalculate the recommended IUC for each modem using the OFDMA channel with the baseline data IUCs. Modems that have a new recommended IUC are activated on the new IUC immediately using a DBC-REQ message. The OFDMA prof-mgmt interval is unaffected by this DBC-REQ.</p> <p><b>Wait</b> – causes the cBR-8 to wait until the next OFDMA prog-mgmt interval, and therefore new RxMER data, before recalculating the recommended IUC for each modem using the OFDMA channel with the baseline data IUCs.</p> <p>Default is <b>cable pma upstream clear-action recalculate</b>. This may result in an immediate change to the modems active data IUC. Upstream profile management again reevaluates the recommended IUC at the next regular profile management interval.</p> |

Table 163: US-PMA Configuration Commands for SNMP/TFTP

| Command                                                             | Description                                                                                                                                                                                                                                                                                                    |
|---------------------------------------------------------------------|----------------------------------------------------------------------------------------------------------------------------------------------------------------------------------------------------------------------------------------------------------------------------------------------------------------|
| <b>[no] cable upstream ofdma-prof-mgmt snmp pnm-rxmer-intercept</b> | <p>Enable docsPnmCmtsUsOfdmaRxMerTable to retrieve RxMER from the profile selection cache instead of triggering new probe measurement on OFDMA channel. Enabling this option saves measurement overhead on the OFDMA channel by using measurements that are already collected.</p> <p>Disabled by default.</p> |
| <b>[no] snmp-server enable traps cable ofdma-cfg-change</b>         | <p>Enable SNMP trap to be sent when OFDMA channel configuration parameter is changed, such as frequency, subcarrier spacing, modulation profile or data-iuc override change, or channel shutdown.</p> <p>Disabled by default.</p>                                                                              |
| <b>[no] cable kman tftp quarantine [timeout &lt;5-1440&gt;]</b>     | <p>Provides the option to globally enable/disable the TFTP quarantine feature. It also allows to optionally configure the timeout in minutes for the entries in the quarantine database.</p> <p>The feature is enabled by default and the default timeout is 15 minutes.</p>                                   |

Table 164: US-PMA Configuration Commands for Kafka

| Command                                                               | Description                                                                                                                                                                                                                                                                                                                                                                                                                                                                                                                                                                                                                                     |
|-----------------------------------------------------------------------|-------------------------------------------------------------------------------------------------------------------------------------------------------------------------------------------------------------------------------------------------------------------------------------------------------------------------------------------------------------------------------------------------------------------------------------------------------------------------------------------------------------------------------------------------------------------------------------------------------------------------------------------------|
| <b>[no]cable telemetry enable</b>                                     | Enables the cBR-8 Telemetry event publication services using Kafka.<br><br>The default is <b>no cable telemetry enable</b> .                                                                                                                                                                                                                                                                                                                                                                                                                                                                                                                    |
| <b>[no] cable telemetry topic us-rxmer publish-rate &lt;count&gt;</b> | Enables the us-rxmer topic publishing and defines the rate at which per-modem RxMER data is published to the Kafka Broker. The default config is <b>no cable telemetry topic us-rxmer</b><br><br><b>publish-rate &lt;count&gt;</b> : down samples before publishing. "publish every Nth RxMER probe"<br><br>Example 1:<br><br>Profile management RxMER interval 5 minutes.<br>Desired us-rxmer publish rate 4 hours.<br><br>cable telemetry topic us-rxmer publish-rate 48<br><br>Example 2:<br><br>Profile management RxMER interval 30 minutes.<br><br>Desired us-rxmer publish rate 1 hour.<br>cable telemetry topic us-rxmer publish-rate 2 |
| <b>[no] cable telemetry topic ofdma-status</b>                        | Enables the publishing of OFDMA channel status events to the Kafka Broker for each OFDMA channel. The default configuration is <b>no cable telemetry topic ofdma-status</b><br><br>Example:<br><br>cable telemetry topic ofdma-status                                                                                                                                                                                                                                                                                                                                                                                                           |
| <b>[no] cable telemetry broker &lt;broker-name&gt;</b>                | Enters the <b>config-cable-telemetry-broker</b> CLI sub-mode to configure the Kafka broker information. The broker-name can be any descriptive ascii string uniquely identifying the broker. A maximum of 2 brokers/broker-clusters can be configured.<br><br>The default configuration is <b>no cable telemetry broker</b>                                                                                                                                                                                                                                                                                                                     |

| Command                                 | Description                                                                                                                                                                                                                                                                                                                                                                                                                                                                                                        |
|-----------------------------------------|--------------------------------------------------------------------------------------------------------------------------------------------------------------------------------------------------------------------------------------------------------------------------------------------------------------------------------------------------------------------------------------------------------------------------------------------------------------------------------------------------------------------|
| <b>bootstrap-servers &lt;string&gt;</b> | <p>A <b>config-cable-telemetry-brokers</b> sub-mode command used to configure the Kafka broker host-port information for this broker/broker-cluster.</p> <p>&lt;string&gt; format is a comma-separated list of host1:port1,host2:port2,...</p> <p>The host must be an IPv4 address.</p> <p>For Kafka broker cluster support, multiple hosts should be configured.</p> <p>Example:</p> <pre>bootstrap-servers 1.2.2.250:9092,1.2.2.252:29092</pre> <p>The default configuration is <b>no bootstrap-servers</b>.</p> |
| <b>topic us-rxmer</b>                   | <p>A <b>config-cable-telemetry-broker</b> sub-mode command that is used to enable the US RxMER topic publishing to this broker.</p> <p>The default configuration is <b>no topic us-rxmer</b>.</p>                                                                                                                                                                                                                                                                                                                  |
| <b>topic ofdma-status</b>               | <p>A <b>config-cable-telemetry-broker</b> sub-mode command that is used to enable the OFDMA-status topic publishing to this broker.</p> <p>The default configuration is <b>no topic ofdma-status</b>.</p>                                                                                                                                                                                                                                                                                                          |

### US-PMA Telemetry Using Kafka - Sample Configuration

```
cable telemetry enable
cable telemetry topic us-rxmer publish-rate 1
cable telemetry topic ofdma-status
cable telemetry broker kafka-broker
bootstrap-address 1.2.2.252
topic us-rxmer
topic ofdma-status
cable telemetry broker bxb-cluster
bootstrap-address 1.2.2.253,1.2.2.254
topic us-rxmer
topic ofdma-status
```

### US-PMA MSBL Override Exec Commands

The external PMA processes RxMER data to calculate MSBL overrides to improve the OFDMA channel performance. Data-IUCs mini-slot modulation values will be adjusted by the PMA to deliver increased throughput, reduced codeword errors, better stability, and quicker response to dynamic changes in channel conditions. To accomplish this, the PMA uses the Exec CLIs below.

#### PMA MSBL Operation Method

The following steps describe the Operation Method for a PMA to override the MSBL values.

1. Stage MSBL overrides for each OFDMA channel, for each Data-IUC.

Using the **cable pma upstream mod-override ... data-iuc ... mslot ... modulation** command, MSBL overrides should be applied across mini-slot ranges to minimize CLI execution. It is not a requirement to set all mini-slot bit-loading values. Any unset values will remain at their configured baseline modulation value. Note: If the PMA overrides an Data-IUC that is unconfigured in the baseline config, the starting mini-slot modulation is NONE (zero bit-loaded).

2. Commit the MSBL Overrides.

Using the **cable pma upstream mod-override ... commit all** command.

3. Depending upon the configured commit-action, modems will begin to utilize the new MSBL override data-IUCs either immediately (recalculate commit-action), or at their next profile-mgmt interval (wait commit-action).

Table 165: US-PMA MSBL Override Exec Commands

| Command                                                                                                                                                       | Description |
|---------------------------------------------------------------------------------------------------------------------------------------------------------------|-------------|
| cable pma upstream mod-override <controller ...<br>  ifIndex ...> data-iuc <iuc> mslot <ms_start><br><ms_end> modulation <msbl-qam> [pilot-pattern<br><1-14>] |             |

| Command | Description                                                                                                                                                                                                                                                                                                                                                                                                                                                                                                                                                                                                                                                                                                                                                                                                                                                                                                                                                                                                                                                                                                                                                                                                                                                                                                                                                                                                                                                                                                                                          |
|---------|------------------------------------------------------------------------------------------------------------------------------------------------------------------------------------------------------------------------------------------------------------------------------------------------------------------------------------------------------------------------------------------------------------------------------------------------------------------------------------------------------------------------------------------------------------------------------------------------------------------------------------------------------------------------------------------------------------------------------------------------------------------------------------------------------------------------------------------------------------------------------------------------------------------------------------------------------------------------------------------------------------------------------------------------------------------------------------------------------------------------------------------------------------------------------------------------------------------------------------------------------------------------------------------------------------------------------------------------------------------------------------------------------------------------------------------------------------------------------------------------------------------------------------------------------|
|         | <p>Add OFDMA IUC MSBL overrides to the staged area.</p> <p>This command is only available when <b>cable upstream pma external</b> is configured. An error is returned if not configured - <b>%PMA-US-FAIL: 'cable pma upstream external' is not configured!</b></p> <p>Upon success, the cBR-8 echoes the command and respond with - <b>%PMA-US-SUCCESS</b></p> <p>The PMA should wait for the response from each command before proceeding to issue subsequent MSBL override commands. A subsequent MSBL override command can overwrite the previous one if there is overlap.</p> <p>The OFDMA channel may be referenced using either the controller or ifIndex:</p> <ul style="list-style-type: none"> <li>• ... controller upstream-cable<br/>         &lt;slot&gt;/&lt;subslot&gt;/&lt;ctrl&gt; us-channel<br/>         &lt;ofdma-chan&gt;</li> <li>• ... ifIndex &lt;ofdma-snmpp-ifIndex&gt;</li> </ul> <p>Data-IUC may be specified as one of:</p> <p>10 Data IUC type 10</p> <p>11 Data IUC type 11</p> <p>12 Data IUC type 12</p> <p>13 Data IUC type 13</p> <p>5 Data IUC type 5</p> <p>6 Data IUC type 6</p> <p>9 Data IUC type 9</p> <p>The PMA is allowed to specify an IUC that is not configured in the cBR-8 base configuration. In this case, any mini-slots not set remain at ZERO bit-loading.</p> <p>Mini-slot range must be valid for the current OFDMA channel configuration.</p> <p>Modulation override values:</p> <p>NONE ZERO bit-loading</p> <p>QPSK QPSK</p> <p>8-QAM 8-QAM</p> <p>16-QAM 16-QAM</p> <p>32-QAM 32-QAM</p> |

| Command                                                                                                                                                                | Description                                                                                                                                                                                                                                                                                                                                                                                                                                                                                                                                                                                                                                                                                                                                                                                                                                                                                          |
|------------------------------------------------------------------------------------------------------------------------------------------------------------------------|------------------------------------------------------------------------------------------------------------------------------------------------------------------------------------------------------------------------------------------------------------------------------------------------------------------------------------------------------------------------------------------------------------------------------------------------------------------------------------------------------------------------------------------------------------------------------------------------------------------------------------------------------------------------------------------------------------------------------------------------------------------------------------------------------------------------------------------------------------------------------------------------------|
|                                                                                                                                                                        | <p>64-QAM 64-QAM</p> <p>128-QAM 128-QAM</p> <p>256-QAM 256-QAM</p> <p>512-QAM 512-QAM</p> <p>1024-QAM 1024-QAM</p> <p>2048-QAM 2048-QAM</p> <p>Pilot-Pattern may be optionally specified. If not specified, the pilot pattern remains at the current setting. If no pilot pattern is specified in the base config, the lowest pilot pattern is chosen.</p>                                                                                                                                                                                                                                                                                                                                                                                                                                                                                                                                           |
| <b>cable pma upstream mod-override &lt;controller ...   ifIndex ...&gt; commit all</b>                                                                                 | Commits the staged MSBL overrides on the channel for all IUCs, causing them to take effect on the OFDMA channel with a single UCD change.                                                                                                                                                                                                                                                                                                                                                                                                                                                                                                                                                                                                                                                                                                                                                            |
| <b>cable pma upstream mod-override &lt;controller ...   ifIndex ...&gt; clear &lt;committed   staged   all&gt;</b><br><b>cable pma upstream mod-override clear all</b> | <p>Removes the MSBL overrides that have been applied by the PMA. The</p> <p><b>Staged</b> – removes any PMA MSBL overrides that have been applied, but not yet committed. This returns the channel to a state where there are no pending overrides. This does not affect the committed overrides currently in effect on the channel.</p> <p><b>Committed</b> – removes any PMA overrides that have been committed. The OFDMA channel is restored to use the configured baseline OFDMA profile. Clearing the committed overrides does not affect any staged overrides.</p> <p><b>All</b> – removes the staged and committed MSBL overrides that have been applied by the PMA from all line cards in the system</p> <p>This command returns the system to its clean state when no PMA has applied to any channel.</p> <p>This is the only exec CLI allowed when the secondary line card is active.</p> |
| <b>cable pma upstream mod-override &lt;controller ...   ifIndex ...&gt; clear counters</b>                                                                             | <p>Reset the US PMA exec command counters and last action timestamp from the specified OFDMA channel.</p> <p>This does not affect any staged or committed MSBL overrides.</p>                                                                                                                                                                                                                                                                                                                                                                                                                                                                                                                                                                                                                                                                                                                        |

Baseline OFDMA channel configuration.

```
cable mod-profile-ofdma 489
subcarrier-spacing 25KHz
initial-rng-subcarrier 32
fine-rng-subcarrier 192
```

```

data-iuc 5 modulation 2048-QAM pilot-pattern 8
data-iuc 6 modulation 1024-QAM pilot-pattern 8
data-iuc 9 modulation 512-QAM pilot-pattern 8
data-iuc 10 modulation 256-QAM pilot-pattern 8
data-iuc 11 modulation 128-QAM pilot-pattern 8
data-iuc 12 modulation 64-QAM pilot-pattern 8
data-iuc 13 modulation 16-QAM pilot-pattern 8

```

#### PMA Control Exec CLIs' Example – MSBL override.

```

Router# cable pma upstream mod-override controller upstream-cable 9/0/0 us-channel
      12 data-iuc 5 mslot 30 59 modulation 1024 pilot-pattern 11

Router# cable pma u mod con up 9/0/0 u 12 d 5 m 90 109 m 1024
Router# cable pma u mod con up 9/0/0 u 12 d 9 m 90 133 m 256 p 10
Router# cable pma u mod con up 9/0/0 u 12 d 10 m 70 79 m 128
Router# cable pma u mod con up 9/0/0 u 12 d 11 m 60 89 m 32 p 10
Router# cable pma u mod con up 9/0/0 u 12 d 12 m 60 89 m NONE
Router# cable pma u mod con up 9/0/0 u 12 commit all

```

#### PMA set default modulation with two bands overrides.

```

Router# cable pma upstream mod-override controller upstream-cable 9/0/0
      us-channel 12 data-iuc 5 mslot 0 236 modulation 1024 pilot-pattern 11
Router# cable pma u mod con up 9/0/0 u 12 d 5 m 24 78 m 2048
Router# cable pma u mod con up 9/0/0 u 12 d 5 m 144 202 m 2048
Router# cable pma u mod con up 9/0/0 u 12 commit all

```

#### PMA updates band override.

```

Router# cable pma u mod con up 9/0/0 u 12 d 5 m 135 143 m 2048 p 10
Router# cable pma u mod con up 9/0/0 u 12 commit all

```



---

**Note** New overrides are relative to the current committed bit-loading.

---

#### PMA reset to baseline then override

```

Router# cable pma u mod con up 9/0/0 u 12 clear committed all
Router# cable pma u mod con up 9/0/0 u 12 d 5 m 122 206 m 2048 p 11
Router# cable pma u mod con up 9/0/0 u 12 commit all

```



---

**Note** New overrides are relative to the baseline configured bit-loading.

---

#### PMA Control Exec CLI Response

The cBR-8 router responds to MSBL override and commit Exec CLIs with success or failure.

```

router# cable pma upstream mod-override controller upstream-cable 9/0/0
      us-channel 12 data-iuc 5 mslot 144 202 modulation 2048-QAM pilot-pattern
11

%PMA-US-SUCCESS (LC9): <cable pma upstream mod-override controller upstream-cable 9/0/0 us-channel
12 data-iuc 5 mslot 144 202 modulation 2048-QAM pilot-pattern 11> successful.

router# cable pma u mod con up 9/0/0 u 12 commit all

%PMA-US-SUCCESS (LC9): <cable pma u mod con up 9/0/0 u 12 commit all> successful.

```



PMA must wait for a response or prompt before issuing the next command (synchronous).

Failure contains a reason string.

```
Router# cable pma u mod con up 9/0/0 us 12 d 5 m 25 30 m 512
```

```
%PMA-US-FAIL (LC9): reason <Invalid mslot range> for <cable pma u mod con up 9/0/0 us 12 d 5 m 25 30 m 512>
```

**Table 166: PMA Control Exec CLI Failure Response**

| <b>%PMA-US-FAIL reason &lt;&gt;</b>                | <b>Command failed to run</b>                                                                                                                                              |
|----------------------------------------------------|---------------------------------------------------------------------------------------------------------------------------------------------------------------------------|
| <b>%PMA-US-FAIL reason &lt;&gt;</b>                | <b>Command failed to run</b>                                                                                                                                              |
| line card not ready                                | line card is not up yet, none of USPMA CLI can be run                                                                                                                     |
| Channel invalid                                    | Can't find the channel                                                                                                                                                    |
| Channel not OFDMA                                  | Channel is not OFDMA                                                                                                                                                      |
| Channel admin state not UP                         | Channel admin state is DOWN, no staging or commit commands can be run on admin DOWN channel                                                                               |
| Channel state not UP                               | Channel operational state is DOWN, staging command can be run but commit command can't be run.                                                                            |
| Invalid IUC                                        | Data IUC is not valid, should not happen as only valid IUC is allowed with syntax check                                                                                   |
| Invalid mslot range                                | Minislot range is out of OFDMA channel minislot range                                                                                                                     |
| Invalid pilot pattern                              | The pilot pattern doesn't match with channel supported pilot pattern, either mismatch with subcarrier spacing or mismatch with existing boosted/non-boosted pilot pattern |
| Too many modulation group                          | The override makes the burst profile too segmented that exceed 126 modulation groups limit on certain IUC per MULPI spec                                                  |
| Memory alloc failure                               | Internal memory allocation failure                                                                                                                                        |
| USPMA not allowed when LCHA secondary LC is active | Command not allowed when LCHA in progress and secondary LC is active                                                                                                      |

### PMA Control Exec CLI Notice

Upon OFDMA channel frequency, subcarrier spacing, modulation profile or data-iuc override change, or any configuration change in the modulation profile, all the PMA override is cleared on the channel.

```
Router# cable upstream controller-profile 10
      us-channel 12 subcarrier-spacing 25KHz
      us-channel 12 modulation-profile 489
      us-channel 12 frequency-range 75000000 85000000
      us-channel 12 data-iuc 5 band 80000000 82000000 modulation 1024-QAM pilot-pattern
11
      cable mod-profile-ofdma 48
```

After PMA override is cleared due to channel configuration change, notification a string is shown on the console when **next** Exec CLI is entered.

```
Router# cable pma upstream mod-override controller upstream-cable 9/0/0
      us-channel 12 data-iuc 5 mslot 144 202 modulation 2048-QAM pilot-pattern
1
```

**%PMA-US-NOTICE (SUP):** Previously configured override config has been cleared on this channel due to modulation profile/freq/subcarrier change by the user. This command run on top of this channel baseline config.

**%PMA-US-SUCCESS (LC9):** <cable pma upstream mod-override controller upstream-cable 9/0/0 us-channel 12 data-iuc 5 mslot 144 202 modulation 2048-QAM pilot-pattern 11> successful.

### Operations That Clear the PMA Override

MSBL overrides clear Exec CLIs.

**cable pma upstream mod-override <controller ... | iffIndex ...> clear <committed | staged> all**

**cable pma upstream mod-override clear all**

OFDMA channel frequency, subcarrier spacing, modulation profile or data-iuc override change, or any configuration change in the modulation profile.

Disable/Enable the PMA feature [**no**] **cable pma upstream external**.

Line Card reloading/rebooting without LCHA. PMA Override is preserved after LCHA switchover and revert.

### US-PMA Integration Notes

- All OFDMA data-iuc's (5, 6, 9, 10, 11, 12, 13) may be overridden, regardless of their state in the baseline config.
  - Minislots that are not overridden or defined in the baseline config default to zero bit-loading.
  - If you must remove an IUC present in the baseline config, the PMA may override the data-iuc with all zero bit-loading. This is an option for IUCs not present in the baseline config as well if a simple common mode of operation for IUC removal is needed.
- The **clear committed all** command removes all data-iuc overrides and update the UCD to baseline.

### UCD Message Size Restriction

- DOCSIS MULPI Spec allows every data IUC to have up to 126 modulation groups after PMA override – that is only 1 or 2 consecutive minislots sharing the same modulation/pilot pattern on average.
- When all 7 data IUCs are overridden to the maximum number of modulation groups, the UCD message is close to 2000 bytes.  $7 * 126 = 882$  modulation groups + around 8 total exclusion bands and unused bands.
- Currently the system supports the OFDMA channel UCD message up to 1515 bytes.
  - A total of 600 modulation groups are supported across all 7 data IUCs.
  - Example override: leave IUC13 not overridden and less than 100 modulation groups each on other 6 data IUCs.
  - The restriction is enforced at the US PMA stage command time.

## US-PMA MSBL Override Show Commands

Table 167: US-PMA MSBL Override Show Commands

| Command                                                                                                                                                              | Description                                                                                                                                                                                                                                                                                                                                                                                                                                                                                                                                                           |
|----------------------------------------------------------------------------------------------------------------------------------------------------------------------|-----------------------------------------------------------------------------------------------------------------------------------------------------------------------------------------------------------------------------------------------------------------------------------------------------------------------------------------------------------------------------------------------------------------------------------------------------------------------------------------------------------------------------------------------------------------------|
| <b>show cable pma upstream &lt;controller ...   ifIndex ...   interface ... &gt; [base   staged   committed   stats   all   mslot-sc-mapping   sc-mslot-mapping]</b> | <p>Provides visibility to the current state of the MSBL overrides as applied by the PMA on the per channel level.</p> <p>The channel can be specified by US controller channel, MD interface US channel or ifIndex channel.</p> <p>Baseline configuration, Staged and Committed overrides can be viewed, as well as the baseline and staged preview and committed data IUC burst profile.</p> <p>Performance data from PMA override can be shown from stats.</p> <p>Minislot to subcarrier and subcarrier to minislot mappings are available to be shown as well.</p> |
| <b>show cable pma upstream &lt;slot&gt;/&lt;subslot&gt; [base   staged   committed   stats   all   summary [total] ]</b>                                             | <p>Provides visibility to the current state of the MSBL overrides as applied by the PMA on the per line card level. Display all the channels on this line card slot that PMA has been applied.</p> <p>Summary output provides the commands counters and last timestamp of the commands on this line card.</p>                                                                                                                                                                                                                                                         |
| <b>show cable pma upstream [base   staged   committed   stats   all   summary [total]]</b>                                                                           | <p>Provides visibility to the current state of the MSBL overrides as applied by the PMA on the system. Displays all the channels on the system that PMA has been applied.</p> <p>Summary output provides the commands counters and last timestamp of the commands on the system.</p>                                                                                                                                                                                                                                                                                  |

### show cable pma ups stats

```

router#show cable pma ups interf ca2/0/0 up 6 stats
===== Ca2/0/0/U6, UC2/0/0:U12, ifIndex:490350 =====
IUC          : 5          6          9          10         11         12         13
-----
Total FEC CWs :5369          33          0          0          0          0          253
Corr FEC CWs  :3631          21          0          0          0          0          0
Uncorr FEC CWs :0          0          0          0          0          0          0
Uncorr CWs%   :0.0          0.0          0.0          0.0          0.0          0.0          0.0
TrafficRxMer (DB):30.50        15.75        0.0          0.0          0.0          0.0          24.0
Total Modems  :0          4          0          0          0          0          4
Base Rate (Mbps) :104.51        94.98        85.45        75.93        66.40        56.87        37.89
Committed Mods :512-QAM~1024-QAM 1024-QAM 512-QAM 256-QAM 256-QAM~1024-QAM 64-QAM 16-QAM
PMA Commit (Mbps) :96.77          94.98        85.45        75.93        97.13        56.87        37.89
PMA Staged (Mbps) :0.0          0.0          0.0          93.57        0.0          0.0          0.0

PMA Status flags: Config Type - EXT Commit-Action - RECALC Clear-Action - RECALC Staged
                  - 0x8 Committed - 0x11 Cleared-by-config - FALSE
PMA Last Staged Timestamp          : Nov 1 12:03:07

```

```

PMA Last Committed Timestamp      : Nov 1 12:03:03
PMA Last Clear by CLI Timestamp   : -
PMA Last Clear by Config Timestamp : -
PMA Exec commands counters:
   Staged   | Committed   | Clear
good fail clear |good fail clear |by-config fail
   5     0     0 | 1     0     0 |      0     0

```

### show cable pma ups summary

```

router#show cable pma upstream summary
PMA Exec commands summary:
  OFDMA   |   Staged   |   Committed   |   Clear   |....
  Channel |good  fail  clear |good  fail  clear |by-ch-cfg  fail |....
-----|-----|-----|-----|-----|-----|-----|-----|-----|
UC2/0/0:U12      5    0    0    1    0    0    0    0    0 |....
Total (LC2):     5    0    0    1    0    0    0    0    0 |....
.....
UC9/0/0:U13      8    1    0    0    0    0    0    1    0 |....
Total (LC9):     8    1    0    0    0    0    0    1    0 |....

```

```

router#show cable pma upstream summary total
PMA Exec commands summary:
  OFDMA   |   Staged   |   Committed   |   Clear   |....
  Channel |good  fail  clear |good  fail  clear |by-ch-cfg  fail |....
-----|-----|-----|-----|-----|-----|-----|-----|
Total (LC2):     5    0    0    1    0    0    0    0    0 |....
Total (LC9):     8    1    0    0    0    0    0    1    0 |....

```

### Continuation of the output:

```

router#show cable pma upstream summary
PMA Exec commands summary:
....|
....|                staged                committed                clear-by-cli                clear-by-ch-cfg
-----|-----|-----|-----|-----|-----|-----|-----|
....| Nov 1 12:03:07  Nov 1 12:03:03                -                -
....| Nov 1 12:03:07  Nov 1 12:03:03                -                -
....
....| Nov 1 12:08:27                -                -  Nov 1 11:50:31
....| Nov 1 12:08:27                -                -  Nov 1 11:50:31

```

```

router#show cable pma upstream summary total
PMA Exec commands summary:
....|
....|                staged                committed                clear-by-cli                clear-by-ch-cfg
-----|-----|-----|-----|-----|-----|-----|-----|
....| Nov 1 12:03:07  Nov 1 12:03:03                -                -
....| Nov 1 12:08:27                -                -  Nov 1 11:50:31

```

### US-PMA RxMer TFTP

The new version 2 RxMer TFTP file header formats with the following new fields are supported:

- RPD ID (MAC Address)
- RPD Port Number

Table 168: Show Commands

| Command                                                                          | Description                                                                                                                                                                                                                                                                 |
|----------------------------------------------------------------------------------|-----------------------------------------------------------------------------------------------------------------------------------------------------------------------------------------------------------------------------------------------------------------------------|
| <b>show platform software kman R0 stats [listener   pnm   tftp   telemetry ]</b> | Provides visibility into the statistics that are maintained in kman for different components that are listed in the options.                                                                                                                                                |
| <b>show platform software kman R0 tftp quarantine</b>                            | Provides visibility into the Kman Pnm TFTP quarantine database.<br><br>It lists the TFTP servers and the associated paths that have been quarantined by the Kman TFTP due to unfavorable conditions and lists the time remaining for each entry in the quarantine database. |

### US-PMA Show Commands

```
Router# show platform software kman RP active stats tftp
```

```
TFTP Client Stats
```

```
-----
TFTP Total Sessions      : 0
TFTP Xfer Success        : 0
TFTP Xfer Failure        : 0

TFTP Server Err          : 0
TFTP WRQ Send Err        : 0
TFTP WRQ Rsp Timeout     : 0
TFTP DAT Send Err        : 0
TFTP DAT Rsp Timeout     : 0
```

```
Router# show platform software kman R0 stats telemetry
```

```
PMA RxMER Telemetry
```

```
-----
PMA RxMER Tx Success     : 2218
PMA RxMER Tx Failure     : 0

OFDMA Status Telemetry
-----
OFDMA Status Tx Success  : 10
OFDMA Status Tx Failure  : 0
```

```
router#show platform software kman R0 tftp quarantine
```

```
KMAN TFTP Feature Info:
```

```
Tftp Qdb Enable          : enabled
Tftp Qdb Timeout(mins)   : 15
```

```
KMAN TFTP Quarantine List:
```

```
  Tftp Server              Time Remaining(min) Tftp Path
-----
```

Table 169: PMA Control Exec CLI Failure Response

| Command                                      | Description                                                      |
|----------------------------------------------|------------------------------------------------------------------|
| <b>show cable kman config</b>                | Displays local config settings relevant to IOSd-SUP and IOSd-CLC |
| <b>show platform software kman R0 config</b> | Displays config settings relevant to KMAN binos process          |

| Command                                             | Description                                           |
|-----------------------------------------------------|-------------------------------------------------------|
| <b>show cable telemetry brokers</b>                 | Displays broker information in IOSd-SUP               |
| <b>show platform software kman R0 kafka brokers</b> | Displays broker information from KMAN process         |
| <b>show platform software kman R0 kafka topics</b>  | Displays kafka topics that are supported by KMAN      |
| <b>show platform software kman R0 kafka stats</b>   | Displays statistics for kafka publishing              |
| <b>show platform software kman R0 ipcecl</b>        | Displays ipcecl information that is supported by KMAN |

Table 170: Enable Commands

| Command                       | Description                                                                         |
|-------------------------------|-------------------------------------------------------------------------------------|
| <b>cable telemetry enable</b> | To Enable Kafka telemetry.                                                          |
| <b>cable snmp pnm enable</b>  | To enable kman which is by default disabled, for both the Kafka and SNMP with TFTP. |

```

router#show cable kman config
KMAN global settings:
  IP Address       : 10.2.0.1
  Telemetry Enable : enabled
  PNM Enable       : enabled
  CCAP-ID          : snowleopard
  Tftp Qdb Enable  : enabled
  Qdb timeout(mins) : 15

KMAN Topics:
  US-RxMER         : enabled
  publish-rate    : 1
snowleopard#show platform software kman R0 kafka broker
Broker: bxb-kafka-01
  Bootstrap.Servers : 1.2.2.251

  Broker State: UP

router# show platform software kman R0 kafka stats

Broker: bxb-kafka-01
Node Names: 1.2.2.251:9092
State: UP

Tx Packets : 2409
Tx Bytes   : 2758075
Tx Retry   : 0
Rx Packets : 2409
Rx Bytes   : 214497
Cur Outq Len : 0
Max Outq Len : 8

Topic      Prod Msg  Prod bytes  Tx Msgs  Tx Msg bytes  Err Msgs
-----
us-rxmer   2227     2240687    2226     2239236       0

router# show platform software kman R0 kafka stats

Broker: bxb-kafka-01

```

```
Node Names: 1.2.2.251:9092
State: UP
```

```
Tx Packets : 2409
Tx Bytes   : 2758075
Tx Retry   : 0
Rx Packets : 2409
Rx Bytes   : 214497
Cur Outq Len : 0
Max Outq Len : 8
```

| Topic    | Prod Msg | Prod bytes | Tx Msgs | Tx Msg bytes | Err Msgs |
|----------|----------|------------|---------|--------------|----------|
| us-rxmer | 2227     | 2240687    | 2226    | 2239236      | 0        |

```
Router# show platform hardware qfp active feature docsis clc-pkt-punt [clear]
Stats for CLC Packets Punted to KMAN
```

```
PNM
```

```
RxMER : 0
UTSC : 0
AQProbe: 0
```

```
Telemetry
RxMER : 70
```

```
Unknown: 0
```

## US-PMA SNMP

### docsPnmCmts UsOfdmaRxMerTable

PMA uses this MIB table to trigger RxMer measurements which is sent to the TFTP server.

```
DocsPnmCmtsUsOfdmaRxMerEntry.[OFDMA channel ifIndex]
docsPnmCmtsUsOfdmaRxMerEnable,
docsPnmCmtsUsOfdmaRxMerCmMac,
docsPnmCmtsUsOfdmaRxMerPreEq,
docsPnmCmtsUsOfdmaRxMerNumAvgs,
docsPnmCmtsUsOfdmaRxMerMeasStatus,
docsPnmCmtsUsOfdmaRxMerFileName,
```

Option is available to avoid probe measurement and send most recent measurement that is collected by profile selection instead. The following command can be optionally configured.

```
cable upstream ofdma-prof-mgmt snmp pnm-rxmer-intercept
```

The above command generates a TFTP file with current profile-mgmt RxMER data. If enabled, avoids additional probe on channel, reducing probe overhead on channel.

### OFDMA Configuration Change Trap

A SNMP trap is added to notify the user that OFDMA channel frequency, subcarrier spacing, modulation profile or data-iuc override change, channel shutdown, or any configuration change has occurred. Configuration to enable/disable the SNMP trap for OFDMA configuration change is as follows:

```
config terminal
[no] snmp-server enable traps cable ofdma-cfg-change
end
```

Default setting is OFDMA Config Change trap disabled. The traps are generated immediately after the OFDMA configuration changes.

The OFDMA Configuration Change Trap is the **linkDown** and **linkUp** SNMP traps (snmpTraps.4, snmpTraps.3) with localIfReason string **OFDMA Configuration Change**, and the OFDMA channel interface descriptor, Example:

```
Community: public
From: 8.5.1.1
sysUpTimeInstance = 22:29:05.18
snmpTrapOID.0 = linkUp
ifIndex.501918 = 501918
ifDescr.501918 = Cable9/0/1-upstream6
ifType.501918 = 278
locIfReason.501918 = OFDMA Configuration Change
ifAdminStatus.501918 = up(1)
ifOperStatus.501918 = up(1)
```

Trap **linkDown** or **linkUp** is based on the OFDMA channel operational status.

### SNMP MIBs of interest for PMA

```
docsIf31CmtsUsOfdmaDataIucStatsEntry OBJECT-TYPE
    SYNTAX DocsIf31CmtsUsOfdmaDataIucStatsEntry
    MAX-ACCESS not-accessible
    STATUS current
    DESCRIPTION
        "The conceptual row of docsIf31CmtsUsOfdmaDataIucStatsTable.
        An instance exists for each Data IUC profile on a given US OFDMA channel."
    INDEX {
        ifIndex,
        docsIf31CmtsUsOfdmaDataIucStatsDataIuc
    } ::= { docsIf31CmtsUsOfdmaDataIucStatsTable 1 }
DocsIf31CmtsUsOfdmaDataIucStatsEntry ::= SEQUENCE
{
    docsIf31CmtsUsOfdmaDataIucStatsDataIuc Unsigned32,
    docsIf31CmtsUsOfdmaDataIucStatsMinislotPilotPattern Unsigned32,
    docsIf31CmtsUsOfdmaDataIucStatsMinislotModulation UsOfdmaModulationType,
    docsIf31CmtsUsOfdmaDataIucStatsTotalCodewords Counter64,
    docsIf31CmtsUsOfdmaDataIucStatsCorrectedCodewords Counter64,
    docsIf31CmtsUsOfdmaDataIucStatsUnreliableCodewords Counter64,
    docsIf31CmtsUsOfdmaDataIucStatsInOctets Counter64,
    docsIf31CmtsUsOfdmaDataIucStatsCtrDiscontinuityTime TimeStamp,
    docsIf31CmtsUsOfdmaDataIucStatsAssignedCmCt Unsigned32,
    docsIf31CmtsUsOfdmaDataIucStatsIucAverageMer TenthdB

DocsIf31CmUsOfdmaChanEntry ::=
SEQUENCE {
    docsIf31CmUsOfdmaChanConfigChangeCt Unsigned32,
    docsIf31CmUsOfdmaChanSubcarrierZeroFreq Unsigned32,
    docsIf31CmUsOfdmaChanFirstActiveSubcarrierNum Unsigned32,
    docsIf31CmUsOfdmaChanLastActiveSubcarrierNum Unsigned32,
    docsIf31CmUsOfdmaChanNumActiveSubcarriers Unsigned32,
    docsIf31CmUsOfdmaChanSubcarrierSpacing SubcarrierSpacingType,
    docsIf31CmUsOfdmaChanCyclicPrefix UsOfdmaCyclicPrefix,
    docsIf31CmUsOfdmaChanRollOffPeriod UsOfdmaRollOffPeriod,
    docsIf31CmUsOfdmaChanNumSymbolsPerFrame Unsigned32,
    docsIf31CmUsOfdmaChanTxPower Unsigned32,
    docsIf31CmUsOfdmaChanPreEqEnabled TruthValue,
    docsIf31CmUsOfdmaChanChannelId Unsigned32

DocsIf31CmtsUsOfdmaChanEntry ::= SEQUENCE {
    docsIf31CmtsUsOfdmaChanTemplateIndex Unsigned32,
    docsIf31CmtsUsOfdmaChanConfigChangeCt Unsigned32,
    docsIf31CmtsUsOfdmaChanTargetRxPower TenthdBmV,
    docsIf31CmtsUsOfdmaChanLowerBdryFreq Unsigned32,
    docsIf31CmtsUsOfdmaChanUpperBdryFreq Unsigned32,
    docsIf31CmtsUsOfdmaChanSubcarrierSpacing SubcarrierSpacingType,
```



```

docsIf31CmtsUsOfdmaChanCyclicPrefix          UsOfdmaCyclicPrefix,
docsIf31CmtsUsOfdmaChanNumSymbolsPerFrame    Unsigned32,
docsIf31CmtsUsOfdmaChanRollOffPeriod         UsOfdmaRollOffPeriod,
docsIf31CmtsUsOfdmaChanPreEqEnable           TruthValue,
docsIf31CmtsUsOfdmaChanFineRngGuardband      Unsigned32,
docsIf31CmtsUsOfdmaChanFineRngNumSubcarriers Unsigned32,
docsIf31CmtsUsOfdmaChanFineRngPreambleLen    Unsigned32,
docsIf31CmtsUsOfdmaChanInitRngGuardband      Unsigned32,
docsIf31CmtsUsOfdmaChanInitRngNumSubcarriers Unsigned32,
docsIf31CmtsUsOfdmaChanInitRngPreambleLen    Unsigned32,
docsIf31CmtsUsOfdmaChanProvAttribMask        AttributeMask,
docsIf31CmtsUsOfdmaChanTxBackoffStart         Integer32,
docsIf31CmtsUsOfdmaChanTxBackoffEnd          Integer32,
docsIf31CmtsUsOfdmaChanRangingBackoffStart   Integer32,
docsIf31CmtsUsOfdmaChanRangingBackoffEnd     Integer32,
docsIf31CmtsUsOfdmaChanUtilization           Unsigned32,
docsIf31CmtsUsOfdmaChanId                    Integer32,
docsIf31CmtsUsOfdmaChanSubcarrierZeroFreq    Unsigned32,
docsIf31CmtsUsOfdmaChanTargetMapInterval     Unsigned32
}

docsIf31CmtsUsOfdmaSubcarrierTypeEntry OBJECT-TYPE
SYNTAX      DocsIf31CmtsUsOfdmaSubcarrierTypeEntry
MAX-ACCESS  not-accessible
STATUS      current
DESCRIPTION
    "The conceptual row of docsIf31CmtsUsOfdmaSubcarrierStatusTable.
    An instance exists for each Profile on a given OFDMA upstream."
INDEX {
    ifIndex,
    docsIf31CmtsUsOfdmaSubcarrierTypeStartSubcarrierId
}
 ::= { docsIf31CmtsUsOfdmaSubcarrierTypeTable 1 }

DocsIf31CmtsUsOfdmaSubcarrierTypeEntry ::=
SEQUENCE {
    docsIf31CmtsUsOfdmaSubcarrierTypeStartSubcarrierId    Unsigned32,
    docsIf31CmtsUsOfdmaSubcarrierTypeEndSubcarrierId      Unsigned32,
    docsIf31CmtsUsOfdmaSubcarrierTypeSubcarrierType       UsOfdmaSubcarrierType
}

```



**Note** All OFDMA data-iuc's (5, 6, 9, 10, 11, 12, 13) may be overridden, regardless of their state in the baseline config.

Minislots that are not overridden and not defined in the baseline config default to zero bit-loading.

If you must remove an IUC present in the baseline config, the PMA may override the data-iuc with all zero bit-loading. This is an option for IUCs not present in the baseline config as well if a simple common mode of operation for IUC removal is needed.

The `clear committed all` command removes all data-iuc overrides and updates the UCD to baseline.

### Kafka Manager (KMAN)

Starting with Cisco IOS XE Dublin 17.12.1x release, a new Binos process was introduced to support Kafka. This process also services the SNMP PNM TFTP requests replacing the legacy Guestshell PNM TFTP application. In addition to the show commands mentioned above that refer to "kman", several system commands are available under the general platform CLIs that provide additional details about the KMAN process status. Refer to **show platform software kman** for these commands.

**SUPHA and SUPPR****SUPHA**

Exec MSBL overrides are maintained across SUPSOs.

KMAN process on the SUP supports SUPSO.

**SUPPR**

Exec MSBL override is maintained across KMAN PRs.

KMAN process on the SUP supports process restart (PR).

Trigger with **test plat soft process exit kman R0 stateless**.

TFTP of PNM data continues functioning after KMAN PR completes.

Some in flight RxMer data will be dropped during the process restart.

**LCHA and LCPR****LCHA**

Exec MSBL overrides is maintained across LCSOs.

TFTP of RxMER continues functioning after the LCSO completes.

Some in flight RxMer data may be dropped during the LCSO.

**LCPR**

Exec MSBL overrides are maintained across IOSd-CLC and CDMAN PRs.

TFTP of RxMER continues functioning after IOSd-CLC or CDMAN PR completes.

Some in flight RxMer data may be dropped during the process restart.

## Feature Information for Proactive Network Management

The following table provides release information about the feature or features described in this module. This table lists only the software release that introduced support for a given feature in a given software release train. Unless noted otherwise, subsequent releases of that software release train also support that feature.

Use Cisco Feature Navigator to find information about platform support and Cisco software image support. To access Cisco Feature Navigator, go to <https://cfng.cisco.com/>. An account on Cisco.com is not required.

**Table 171: Feature Information for Upstream Triggered Spectrum Capture - Proactive Network Management**

| Feature Name                                   | Releases                        | Feature Information                                                                                                   |
|------------------------------------------------|---------------------------------|-----------------------------------------------------------------------------------------------------------------------|
| DOCSIS 3.1 Upstream Triggered Spectrum Capture | Cisco IOS XE Gibraltar 16.10.1  | This feature was integrated into Cisco IOS XE Gibraltar 16.10.1 on the Cisco cBR Series Converged Broadband Routers.  |
| MAX-HOLD trigger mode                          | Cisco IOS XE Gibraltar 16.10.1d | This feature was integrated into Cisco IOS XE Gibraltar 16.10.1d on the Cisco cBR Series Converged Broadband Routers. |

| Feature Name                                                     | Releases                        | Feature Information                                                                                                   |
|------------------------------------------------------------------|---------------------------------|-----------------------------------------------------------------------------------------------------------------------|
| Support PNM output format 'timeIQ' and UTSC trigger mode 'cmMac' | Cisco IOS XE Gibraltar 16.12.1x | This feature was integrated into Cisco IOS XE Gibraltar 16.12.1x on the Cisco cBR Series Converged Broadband Routers. |
| Proactive Network Management using OFDMA RxMER Probes            | Cisco IOS XE Gibraltar 16.12.1y | This feature was integrated into Cisco IOS XE Gibraltar 16.12.1y on the Cisco cBR Series Converged Broadband Routers. |





## CHAPTER 45

# Downstream Power Tilt

---

The Downstream Power tilt feature is used to correct cable loss in the head-end to produce a flat power spectrum for all channels in the controller port.

- [Hardware Compatibility Matrix for the Cisco cBR Series Routers, on page 817](#)
- [Information about Downstream Power Tilt, on page 819](#)
- [How to Configure the Downstream Power Tilt, on page 819](#)
- [Feature Information for Downstream Power Tilt, on page 821](#)

## Hardware Compatibility Matrix for the Cisco cBR Series Routers



---

**Note** The hardware components that are introduced in a given Cisco IOS-XE Release are supported in all subsequent releases unless otherwise specified.

---

Table 172: Hardware Compatibility Matrix for the Cisco cBR Series Routers

| Cisco CMTS Platform                    | Processor Engine                                                                                                                                                                                  | Interface Cards                                                                                                                                                                                                                                                                                                                                                                                                                                                                                                                                                                                                                                                                                                                                                                                 |
|----------------------------------------|---------------------------------------------------------------------------------------------------------------------------------------------------------------------------------------------------|-------------------------------------------------------------------------------------------------------------------------------------------------------------------------------------------------------------------------------------------------------------------------------------------------------------------------------------------------------------------------------------------------------------------------------------------------------------------------------------------------------------------------------------------------------------------------------------------------------------------------------------------------------------------------------------------------------------------------------------------------------------------------------------------------|
| Cisco cBR-8 Converged Broadband Router | <p><b>Cisco IOS-XE Release 16.5.1 and Later Releases</b></p> <p>Cisco cBR-8 Supervisor:</p> <ul style="list-style-type: none"> <li>• PID—CBR-SUP-250G</li> <li>• PID—CBR-CCAP-SUP-160G</li> </ul> | <p><b>Cisco IOS-XE Release 16.5.1 and Later Releases</b></p> <p>Cisco cBR-8 CCAP Line Cards:</p> <ul style="list-style-type: none"> <li>• PID—CBR-LC-8D30-16U30</li> <li>• PID—CBR-LC-8D31-16U30</li> <li>• PID—CBR-RF-PIC</li> <li>• PID—CBR-RF-PROT-PIC</li> <li>• PID—CBR-CCAP-LC-40G</li> <li>• PID—CBR-CCAP-LC-40G-R</li> <li>• PID—CBR-CCAP-LC-G2-R</li> <li>• PID—CBR-SUP-8X10G-PIC</li> <li>• PID—CBR-2X100G-PIC</li> </ul> <p>Digital PICs:</p> <ul style="list-style-type: none"> <li>• PID—CBR-DPIC-8X10G</li> <li>• PID—CBR-DPIC-2X100G</li> </ul> <p>Cisco cBR-8 Downstream PHY Module:</p> <ul style="list-style-type: none"> <li>• PID—CBR-D31-DS-MOD</li> </ul> <p>Cisco cBR-8 Upstream PHY Modules:</p> <ul style="list-style-type: none"> <li>• PID—CBR-D31-US-MOD</li> </ul> |



**Note** Do not use DPICs (8X10G and 2x100G) to forward IP traffic, as it may cause buffer exhaustion, leading to line card reload.

The only allowed traffic on a DPIC interface is DEPI, UEPI, and GCP traffic from the Cisco cBR-8 router to Remote PHY devices. Other traffic such as DHCP, SSH, and UTSC should flow via another router, since DPICs cannot be used for normal routing.

## Information about Downstream Power Tilt

The downstream power tilt feature is used to correct cable loss in the head-end to produce a flat power spectrum for all channels on the controller port.



**Note** There may be noise floor degradation on the failover path (following linecard switchover) with this feature enabled.

## Restrictions for Configuring Downstream Power Profile

The downstream power tilt feature and OFDM power profile feature are mutually exclusive. They cannot be configured at the same time.

## How to Configure the Downstream Power Tilt

### Configuring Downstream Power Tilt

Downstream power tilt applies to all the SCQAM or OFDM channels on the downstream. To configure downstream power tilt for a controller port, use the power-tilt configuration command under the downstream controller port.

```
enable
configure terminal
controller Integrated-Cable slot/subslot/port
max-ofdm-spectrum value
max-carrier value
base-channel-power value
power-tilt mode loss max-frequency freq-max
rf-chan start_id [end_id]
type value
rf-output value
power-adjust value
qam-profile id
docsis-channel-id id
ofdm channel-profile id start-frequency value width value [plc value]
```

Below is an example:

```
controller Integrated-Cable 3/0/0
max-ofdm-spectrum 192000000
max-carrier 32
base-channel-power 34
power-tilt linear 4.0 max-frequency 696000000
rf-chan 0 31
type DOCSIS
frequency 261000000
rf-output NORMAL
power-adjust -2.0
```

## Verifying Downstream Power Tilt Configuration

```

qam-profile 1
docsis-channel-id 1
rf-chan 158
power-adjust 0
docsis-channel-id 159
ofdm channel-profile 20 start-frequency 600000000 width 96000000 plc 645000000

```

In the above configuration steps, there is a command **power-tilt mode loss max-frequency freq-max**, where the *mode* represent a formula that calculates the loss of a coax cable at a frequency F, given the loss at *freq-max* is known. It provides two options to select:

- linear:  $\text{loss}_F = \text{loss}_{\text{freq-max}} * (F / \text{freq-max})$
- cable-loss-approx:  $\text{loss}_F = \text{loss}_{\text{freq-max}} * \text{SQRT}((\text{freq-max} - F) / \text{freq-max})$

*loss* is the measured cable loss at *freq-max*, specified in 1/10 dB.

## Verifying Downstream Power Tilt Configuration

To display the downstream power tilt details, use the **show cable controller integrated-cable** command as given in the following example. This command will display the actual SCQAM and OFDM channel power levels as set by the DS Power Tilt command. For OFDM channels, the power level displayed represents the center frequency 6-MHz band power level.

```
Router# show controller Integrated-Cable 1/0/1 rf-chan 0-162
```

| Chan | State | Admin | Frequency | Type   | Annex | Mod | srate | Interleaver | dcid | power | output |
|------|-------|-------|-----------|--------|-------|-----|-------|-------------|------|-------|--------|
| 0    | UP    | UP    | 261000000 | DOCSIS | B     | 256 | 5361  | I32-J4      | 1    | 29.9  | NORMAL |
| 1    | UP    | UP    | 267000000 | DOCSIS | B     | 256 | 5361  | I32-J4      | 2    | 30.0  | NORMAL |
| 2    | UP    | UP    | 273000000 | DOCSIS | B     | 256 | 5361  | I32-J4      | 3    | 30.0  | NORMAL |
| 3    | UP    | UP    | 279000000 | DOCSIS | B     | 256 | 5361  | I32-J4      | 4    | 30.0  | NORMAL |
| 4    | UP    | UP    | 285000000 | DOCSIS | B     | 256 | 5361  | I32-J4      | 5    | 30.1  | NORMAL |
| 5    | UP    | UP    | 291000000 | DOCSIS | B     | 256 | 5361  | I32-J4      | 6    | 30.1  | NORMAL |
| 6    | UP    | UP    | 297000000 | DOCSIS | B     | 256 | 5361  | I32-J4      | 7    | 30.2  | NORMAL |
| 7    | UP    | UP    | 303000000 | DOCSIS | B     | 256 | 5361  | I32-J4      | 8    | 30.2  | NORMAL |
| 8    | UP    | UP    | 309000000 | DOCSIS | B     | 256 | 5361  | I32-J4      | 9    | 30.2  | NORMAL |
| 9    | UP    | UP    | 315000000 | DOCSIS | B     | 256 | 5361  | I32-J4      | 10   | 30.3  | NORMAL |
| 10   | UP    | UP    | 321000000 | DOCSIS | B     | 256 | 5361  | I32-J4      | 11   | 30.3  | NORMAL |
| 11   | UP    | UP    | 327000000 | DOCSIS | B     | 256 | 5361  | I32-J4      | 12   | 30.3  | NORMAL |
| 12   | UP    | UP    | 333000000 | DOCSIS | B     | 256 | 5361  | I32-J4      | 13   | 30.4  | NORMAL |
| 13   | UP    | UP    | 339000000 | DOCSIS | B     | 256 | 5361  | I32-J4      | 14   | 30.4  | NORMAL |
| 14   | UP    | UP    | 345000000 | DOCSIS | B     | 256 | 5361  | I32-J4      | 15   | 30.4  | NORMAL |
| 15   | UP    | UP    | 351000000 | DOCSIS | B     | 256 | 5361  | I32-J4      | 16   | 30.5  | NORMAL |
| 16   | UP    | UP    | 357000000 | DOCSIS | B     | 256 | 5361  | I32-J4      | 17   | 30.5  | NORMAL |
| 17   | UP    | UP    | 363000000 | DOCSIS | B     | 256 | 5361  | I32-J4      | 18   | 30.5  | NORMAL |
| 18   | UP    | UP    | 369000000 | DOCSIS | B     | 256 | 5361  | I32-J4      | 19   | 30.6  | NORMAL |
| 19   | UP    | UP    | 375000000 | DOCSIS | B     | 256 | 5361  | I32-J4      | 20   | 30.6  | NORMAL |
| 20   | UP    | UP    | 381000000 | DOCSIS | B     | 256 | 5361  | I32-J4      | 21   | 30.6  | NORMAL |
| 21   | UP    | UP    | 387000000 | DOCSIS | B     | 256 | 5361  | I32-J4      | 22   | 30.7  | NORMAL |
| 22   | UP    | UP    | 393000000 | DOCSIS | B     | 256 | 5361  | I32-J4      | 23   | 30.7  | NORMAL |
| 23   | UP    | UP    | 399000000 | DOCSIS | B     | 256 | 5361  | I32-J4      | 24   | 30.7  | NORMAL |
| 24   | UP    | UP    | 405000000 | DOCSIS | B     | 256 | 5361  | I32-J4      | 25   | 30.8  | NORMAL |
| 25   | UP    | UP    | 411000000 | DOCSIS | B     | 256 | 5361  | I32-J4      | 26   | 30.8  | NORMAL |
| 26   | UP    | UP    | 417000000 | DOCSIS | B     | 256 | 5361  | I32-J4      | 27   | 30.8  | NORMAL |
| 27   | UP    | UP    | 423000000 | DOCSIS | B     | 256 | 5361  | I32-J4      | 28   | 30.9  | NORMAL |
| 28   | UP    | UP    | 429000000 | DOCSIS | B     | 256 | 5361  | I32-J4      | 29   | 30.9  | NORMAL |
| 29   | UP    | UP    | 435000000 | DOCSIS | B     | 256 | 5361  | I32-J4      | 30   | 30.9  | NORMAL |
| 30   | UP    | UP    | 441000000 | DOCSIS | B     | 256 | 5361  | I32-J4      | 31   | 30.9  | NORMAL |
| 31   | UP    | UP    | 447000000 | DOCSIS | B     | 256 | 5361  | I32-J4      | 32   | 31.0  | NORMAL |

```
Chan State Admin Mod-Type Start Width PLC Profile-ID dcid power output Frequency
```



158 UP UP OFDM 600000000 96000000 645000000 22

159 33.9

NORMAL

## Feature Information for Downstream Power Tilt

Use Cisco Feature Navigator to find information about the platform support and software image support. Cisco Feature Navigator enables you to determine which software images support a specific software release, feature set, or platform. To access Cisco Feature Navigator, go to the <https://cfng.cisco.com/> link. An account on the Cisco.com page is not required.



**Note** The following table lists the software release in which a given feature is introduced. Unless noted otherwise, subsequent releases of that software release train also support that feature.

**Table 173: Feature Information for Downstream Power Tilt**

| Feature Name          | Releases                 | Feature Information                                                                                          |
|-----------------------|--------------------------|--------------------------------------------------------------------------------------------------------------|
| Downstream Power Tilt | Cisco IOS XE Fuji 16.7.1 | This feature was introduced on Cisco IOS XE Fuji 16.7.1 on the Cisco cBR Series Converged Broadband Routers. |





## CHAPTER 46

# Controller Profile Configuration

---

This document describes how to configure the controller profile on the Cisco cBR Series Converged Broadband Router.

- [Hardware Compatibility Matrix for the Cisco cBR Series Routers](#), on page 823
- [Information about Controller Profile Configuration](#), on page 825
- [How to Configure the Controller Profile](#), on page 825
- [Support for RPHY GCP TLV 98.3 \(BaseTargetRxPower\)](#), on page 829
- [Feature Information for Controller Profile Configuration](#), on page 838

## Hardware Compatibility Matrix for the Cisco cBR Series Routers



---

**Note** The hardware components that are introduced in a given Cisco IOS-XE Release are supported in all subsequent releases unless otherwise specified.

---

Table 174: Hardware Compatibility Matrix for the Cisco cBR Series Routers

| Cisco CMTS Platform                    | Processor Engine                                                                                                                                                                                  | Interface Cards                                                                                                                                                                                                                                                                                                                                                                                                                                                                                                                                                                                                                                                                                                                                                                                 |
|----------------------------------------|---------------------------------------------------------------------------------------------------------------------------------------------------------------------------------------------------|-------------------------------------------------------------------------------------------------------------------------------------------------------------------------------------------------------------------------------------------------------------------------------------------------------------------------------------------------------------------------------------------------------------------------------------------------------------------------------------------------------------------------------------------------------------------------------------------------------------------------------------------------------------------------------------------------------------------------------------------------------------------------------------------------|
| Cisco cBR-8 Converged Broadband Router | <p><b>Cisco IOS-XE Release 16.5.1 and Later Releases</b></p> <p>Cisco cBR-8 Supervisor:</p> <ul style="list-style-type: none"> <li>• PID—CBR-SUP-250G</li> <li>• PID—CBR-CCAP-SUP-160G</li> </ul> | <p><b>Cisco IOS-XE Release 16.5.1 and Later Releases</b></p> <p>Cisco cBR-8 CCAP Line Cards:</p> <ul style="list-style-type: none"> <li>• PID—CBR-LC-8D30-16U30</li> <li>• PID—CBR-LC-8D31-16U30</li> <li>• PID—CBR-RF-PIC</li> <li>• PID—CBR-RF-PROT-PIC</li> <li>• PID—CBR-CCAP-LC-40G</li> <li>• PID—CBR-CCAP-LC-40G-R</li> <li>• PID—CBR-CCAP-LC-G2-R</li> <li>• PID—CBR-SUP-8X10G-PIC</li> <li>• PID—CBR-2X100G-PIC</li> </ul> <p>Digital PICs:</p> <ul style="list-style-type: none"> <li>• PID—CBR-DPIC-8X10G</li> <li>• PID—CBR-DPIC-2X100G</li> </ul> <p>Cisco cBR-8 Downstream PHY Module:</p> <ul style="list-style-type: none"> <li>• PID—CBR-D31-DS-MOD</li> </ul> <p>Cisco cBR-8 Upstream PHY Modules:</p> <ul style="list-style-type: none"> <li>• PID—CBR-D31-US-MOD</li> </ul> |



**Note** Do not use DPICs (8X10G and 2x100G) to forward IP traffic, as it may cause buffer exhaustion, leading to line card reload.

The only allowed traffic on a DPIC interface is DEPI, UEPI, and GCP traffic from the Cisco cBR-8 router to Remote PHY devices. Other traffic such as DHCP, SSH, and UTSC should flow via another router, since DPICs cannot be used for normal routing.

# Information about Controller Profile Configuration

As density increases with the merging of CMTS and UEQAM functions in the same device, the current controller configuration method becomes too complex and difficult. There are too many identical lines of configuration.

To simplify the controller configuration, a new concept called controller profile is introduced. A controller profile is a group of configuration parameters that apply to downstream and upstream controller, the benefits include:

- Speed up deployment
- Simplify cBR-8 deployment, configuration and troubleshooting
- Common configurations across nodes/regions
- Consistency across Cisco products for common functions

## How to Configure the Controller Profile

User configures I-CMTS controllers using legacy controller configuration commands by default. If user wants to use I-CMTS controller profile, needs to enable it first with **cable controller-profile I-CMTS enable** command.

**Note**

- If user wants to configure controller using profile, it is recommended to start configuration on a “clean” CMTS without any legacy command configured in Integrated-Cable and Upstream-Cable controllers. Do not switch over between legacy configuration and profile.
- When modifying controller profile, all related controllers will be changed. So if user wants to configure a specific controller, for example, modify the base-channel power of a controller, user should not bind this controller to a profile together with other controllers.
- Legacy controller configuration commands are not supported if I-CMTS controller-profile is enabled.
- Legacy controller configuration cannot be shown in running-config if I-CMTS controller-profile is enabled.

## Configuring Downstream Controller Profile

To configure downstream controller profile, use the steps below:

```
enable
configure terminal
cable downstream controller-profile id [RPHY|I-CMTS]
base-channel-power value
max-carrier value
freq-profile id
max-ofdm-spectrum value
```

```

ofdm-freq-excl-band start-frequency value width value
rf-chan start_id [end_id]
type value
rf-output value
power-adjust value
qam-profile id
docsis-channel-id id
power-profile id
ofdm channel-profile id start-frequency value width value [plc value]

enable
configure terminal
controller integrated-cable slot/subslot/port
profile id

```

Below is an example:

```

cable downstream controller-profile 0 I-CMTS
max-carrier 32
base-channel-power 34
rf-chan 0 3
type DOCSIS
frequency 111000000
rf-output NORMAL
qam-profile 1
docsis-channel-id 1

controller integrated-cable 2/0/0
profile 0

```



#### Note

- When configure a new I-CMTS controller profile, keyword I-CMTS is needed. If input RPHY or do not input any keyword, the system will consider it as a RPHY controller profile. Once a profile type (RPHY/I-CMTS) is set, it cannot be modified.
- Updating a profile will affect all the controllers bond with it. To delete a profile that bond with controller, user must unbind all the controllers first. All rf-channel configuration in controller will be deleted after unbind.
- At least 8 QAM channels should be configured to get the right power. Single continuous wave (CW) mode is not supported.

## Verifying Downstream Controller Profile Configuration

Use the **show cable downstream controller-profile** command to verify the configuration of the downstream controller profile.

```

Router# show cable downstream controller-profile 0
Downstream controller-profile 0, type I-CMTS
Description:
Downstream controller-profile 0 is being used by controller Integrated-Cable:
 2/0/0,
Admin: UP
MaxOfdmSpectrum: 192000000
MaxCarrier: 128

```

```

BasePower: 33.0 dBmV
Mode: normal
Frequency profile: unconfigured
DS Splitting: No
OFDM frequency exclusion bands: None

```

Configured RF Channels:

| Chan | Admin | Frequency | Type   | Annex | Mod | srates | Qam-profile | dcid | power | output |
|------|-------|-----------|--------|-------|-----|--------|-------------|------|-------|--------|
| 0    | UP    | 213000000 | DOCSIS | B     | 256 | 5361   | 1           | 1    | 33.0  | NORMAL |
| 1    | UP    | 219000000 | DOCSIS | B     | 256 | 5361   | 1           | 2    | 33.0  | NORMAL |
| 2    | UP    | 225000000 | DOCSIS | B     | 256 | 5361   | 1           | 3    | 33.0  | NORMAL |
| 3    | UP    | 231000000 | DOCSIS | B     | 256 | 5361   | 1           | 4    | 33.0  | NORMAL |
| 4    | UP    | 237000000 | DOCSIS | B     | 256 | 5361   | 1           | 5    | 33.0  | NORMAL |
| 5    | UP    | 243000000 | DOCSIS | B     | 256 | 5361   | 1           | 6    | 33.0  | NORMAL |

In the above output, integrated-cable 2/0/0 is bond to profile 0. So the output of the **show controllers integrated-Cable 2/0/0 rf-channel 0 5** should match the above output. See the example below:

```
Router# show controllers integrated-cable 2/0/0 rf-channel 0-5
```

```

...
Chan Admin Frequency Type Annex Mod srates Qam-profile dcid power output
0 UP 213000000 DOCSIS B 256 5361 1 1 33.0 NORMAL
1 UP 219000000 DOCSIS B 256 5361 1 2 33.0 NORMAL
2 UP 225000000 DOCSIS B 256 5361 1 3 33.0 NORMAL
3 UP 231000000 DOCSIS B 256 5361 1 4 33.0 NORMAL
4 UP 237000000 DOCSIS B 256 5361 1 5 33.0 NORMAL
5 UP 243000000 DOCSIS B 256 5361 1 6 33.0 NORMAL

```

To check if the parameters in a profile match with the ones configured, use the **show running-config [all] | section cable downstream controller-profile** command as shown in the example below:

```

Router# show running-config | section downstream controller-profile
cable downstream controller-profile 0 I-CMTS
max-carrier 32
base-channel-power 34
rf-chan 0 3
type DOCSIS
frequency 111000000
rf-output NORMAL
qam-profile 1
docsis-channel-id 1

```

## Configuring Upstream Controller Profile

To configure upstream controller profile, use the steps below:

```

enable
configure terminal
cable upstream controller-profile id [RPHY|I-CMTS]
us-channel id {chan-class-id id}channel-width {first-choice-width
[last-choice-width]}|docsis-mode{atdma | tdma |
tdma-atdma}|equalization-coefficient|frequencyvalue|hop-priority{frequency
modulation channel-width| modulation frequency channel-width| frequency
channel-width modulation}|ingress-noise-cancellation
interval|maintain-psd|max-logical-chans id|minislots-size
value|modulation-profile
primary-profile-number[secondary-profile-number] [tertiary-profile-number] |power-level
value|rng-holdoff priority|specsvl error-adaptive-profile id|spectrum-group

```

```
id|threshold {cnr-profiles value [value]|corr-fec value|hysteresis
value|snr-profiles value [value]|corr-fec value}
```

```
enable
configure terminal
controller upstream-cable slot/subslot/port
profile id
```



- Note**
- When configure a new I-CMTS controller profile, keyword I-CMTS is needed. If input RPHY or do not input any keyword, the system will consider it as a RPHY controller profile. Once a profile type (RPHY/I-CMTS) is set, it cannot be modified.
  - Updating a profile will affect all the controllers bond with it. To delete a profile that bond with controller, user must unbind all the controllers first.
  - OFDMA does not support the use of profile in this release.

## Verifying Upstream Controller Profile Configuration

Use the **show cable upstream controller-profile** command to verify the configuration of the upstream controller profile.

```
Router# show cable upstream controller-profile 0
Upstream controller-profile 0, type I-CMTS
Description:
Upstream controller-profile 0 is being used by controller Upstream-Cable:
9/0/0

Controller Upstream-Cable
...
Upstream-channel 0
chan-class-id           : 0x0
channel-width           : 1600000 1600000
docsis-mode              : atdma
equalization-coefficient : TRUE
frequency                : 5000000
...
modulation-profile      : 221
...
shutdown                : FALSE
...
```

In the above output, upstream-cable 9/0/0 is bond to profile 0. So the output of the **show controllers upstream-Cable 9/0/0 us-channel 0** should match the above output. See the example below:

```
Router# show controllers upstream-Cable 9/0/0 us-channel 0
...
Controller 9/0/0 upstream 0 AdminState:UP OpState: UP
atdma mode enabled
Frequency 5.000 MHz, Channel Width 1.600 MHz, Symbol Rate 1.280 Msps
Modulation Profile Group 221
```

To check if the parameters in a profile match with the ones configured, use the **show running-config [all] | section cable upstream controller-profile** command as shown in the example below:



```

Router# show running-config | s cable upstream controller-profile 0
cable upstream controller-profile 0 I-CMTS
  us-channel 0 channel-width 1600000 1600000
  us-channel 0 docsis-mode atdma
  us-channel 0 minislots-size 4
  us-channel 0 modulation-profile 221
  us-channel 0 shutdown
...

```

## Support for RPHY GCP TLV 98.3 (BaseTargetRxPower)

Table 175: Feature History

| Feature Name                                      | Release Information            | Feature Description                                                                                                                                                                                                                                        |
|---------------------------------------------------|--------------------------------|------------------------------------------------------------------------------------------------------------------------------------------------------------------------------------------------------------------------------------------------------------|
| Support for RPHY GCP TLV 98.3 (BaseTargetRxPower) | Cisco IOS XE Cupertino 17.9.1w | This feature introduces TLV 98.3 support for cBR-8 routers. Use the <b>base-power-rx-level-1_6Mhz</b> option under <b>cable upstream controller-profile controller-profile-number</b> to enable the base power configuration for the entire upstream port. |

In releases before Cisco IOS XE Cupertino 17.9.1w:

- On cBR-8 routers, the MSOs have the option to configure the upstream power only at the upstream channel level on the RPD. Cisco RPD solution implements the total absolute power per channel that is calculated with reference to 0dBmV/6.4 MHz. This means that the total power of the entire upstream channel is always constant irrespective of the channel width and therefore the power spectral density of the channel decreases for larger channels.
- **Upstream Power:** Cisco RPD supports **total absolute power** per channel in reference to 0dBmV/6.4MHz. The total power of the entire upstream channel is always constant irrespective of the channel width and therefore the power spectral density of the channel decreases for larger channels.

The implementation of upstream power for different channel widths is as specified below:

- For the 1.6-MHz channel, power per 1.6MHz bandwidth is 0dBmV, total power is 0 dBmV.
- For the 3.2-MHz channel, power per 1.6MHz bandwidth is -3dBmV, total power is 0 dBmV.
- For the 6.4-MHz channel, power per 1.6MHz bandwidth is -6 dBmV, total power is 0 dBmV.

(Or)

- For the 1.6-MHz channel, power per 6.4MHz bandwidth is +6dBmV, total power is 0 dBmV.
- For the 3.2-MHz channel, power per 6.4MHz bandwidth is +3dBmV, total power is 0 dBmV.

### TLV 98.3 BaseTargetRxPower

Starting with Cisco IOS XE Cupertino 17.9.1w, TLV 98.3 is supported on cBR-8 routers.

- If the target rx base power is configured on an upstream RF port in cbr8, upstream power calculations are done with reference to 1.6MHz bandwidth per the CableLabs specification.

- The upstream base power configuration is configured on cbr8 in units of dBmV per 1.6MHz bandwidth. The total channel power increases with increasing channel width.
- The DOCSIS CableLabs specification defines TLV 98.3 as: *This attribute is used to configure the base target power reference level for upstream signals received on all upstream channels from the selected US RF port. The value of this attribute is specified as average power in units of 0.1 dBmV per 1.6 MHz of RF bandwidth.*
- The supported range for TLV 98.3 is from -200 to +400 (-20 dBmV to +40 dBmV] per 1.6 MHz of RF spectrum per the CableLabs specification.
- The actual range supported by the Cisco RPD for this TLV 98.3 attribute varies based on the rpd type and is specified in the cli helpstrings during configuration of this parameter.
- The OOB-55d1 feature uses a constant value for VGA gain setting from internal calibration data. It does not follow the change in port VGA due to any DOCSIS channel power level configuration changes. The per channel gain can be modified to compensate for VGA port gain changes for tlv98.3 configuration on OOB-55d1 channels. We do not support setting up the power adjust for 55-D2 US channels.
- In releases before Cisco IOS XE Cupertino 17.9.1w, the NDR/NDF feature power adjust follows the change in VGA gain settings. In Cisco IOS XE Cupertino 17.9.1w and later, the power adjust for NDR/NDF in TLV 95.5 follows similar behavior with change in VGA if any from TLV 98.3.
- With TLV 98.3 enabled, the per channel power config TLVs are **true power adjusts**. The TLVs for different upstream channel types are the following:
  - UsScQamChannelConfig.TargetRxPowerAdjust (TLV 65.9)
  - UsOfdmaChannelConfig.TargetRxPowerAdjsut (TLV 66.13)
  - UsOob55d1.TargetRxPowerAdjust (TLV 92.7)
  - NdrConfig.TargetRxPowerAdjust (TLV 95.5)

**Table 176: TLV 98.3 BaseTargetRxPower Supported Releases**

| Platform   | Release                                              |
|------------|------------------------------------------------------|
| c-BR8      | Cisco IOS XE Cupertino 17.9.1w and later             |
| Cisco RPHY | RPD v10.4. Supported on Cisco RPD 1x2, 3x6, and 6x12 |



**Note** TLV 98.3 BaseTargetRxPower does not support HAshef and cnBR.

### RPD Modules for TLV 98.3 BaseTargetRxPower

- RPD has a port level amplifier VGA which affects the power levels on the entire upstream RF port – for all the channels on the US port.
- RPD also has a module that is called nb-gain which is used to fine tune the per-channel power adjustments if any configured on the core.

- TLV 98.3 defines the upstream power for the whole port – it is used to directly configure the value of the VGA on the RPD.
- With TLV 98.3 enabled, the per-channel power adjusts on the core directly modifies the nb-gain for that channel on the RPD and has no effect on the overall port power.

In releases before Cisco IOS XE Cupertino 17.9.1w, Cisco RPD supports **total absolute power** per channel in reference to 0dBmV/6.4MHz. This means that the total power of the entire upstream channel is always constant irrespective of the channel width and therefore the power spectral density of the channel decreases for larger channels.

At the RPD upstream port (service group) level, the Remote PHY standard allows a CCAP core to configure a base target power reference level for all upstream signals from a given US RF port. This reference level is specified as a power spectral density (dBmV per 1.6 MHz) through GCP TLV 98.3, which corresponds to `UsRfPort.BaseTargetRxPower`.

The allowed range for upstream controller port base power configuration per CableLabs specification is -20 to +40 dBmV/1.6MHz. Cisco RPD 1x2 supports only the following ranges for the `tlv98.3` configuration: -10 to +29 dBmV/1.6MHz for `rphy-node` and -25 to +10 dBmV/1.6MHz for `rphy-shelf`. Since there can be multiple RPDs per upstream controller port, you must pay attention to the RPD-specific capabilities, to correctly configure the base port power values. The software does not restrict the configuration to allow multiple RPD vendors using the same upstream controller profile. You can reconfigure the power levels at the per-channel level appropriately.

### US RF Port Power Command

cBR-8 routers support RPHY GCP TLV 98.3 - `BaseTargetRxPower` for the upstream controller port on the RPD. The base power config can be applied to both `cable upstream controller-profile` and `cable rpd` level. If configured at both levels, the configuration at the `cable rpd` level takes priority for that rpd. SUP HA is supported for this TLV. The new CLI for upstream controller profile to configure upstream RF port base power (TLV 98.3)

Use the **base-power-rx-level-1\_6Mhz** option (*Base target power level in units of dBmV/1.6MHz*) under **cable upstream controller-profile** to enable base power configuration for the entire upstream port.  
**base-power-rx-level-1\_6Mhz** - Base target power level in in units of dBmV/1.6MHz.

```
router(config)#cable upstream controller-profile 499
router(config-controller-profile)#base-power-rx-level-1_6Mhz ?
<-20 - 40> Supported ranges: -10~29 for rphy-node, -25~10 for rphy-shelf(ref pt:0dBmV/1.6MHz)
```



#### Note

- This configuration affects all RPDs using the configured profile.
- Configuring US port power may require reconfiguration of channel power levels.

With TLV 98.3 enabled, the existing CLI is overloaded to implement changes for per-channel power TLV 65.9 / 66.13

NDR/NDF channel power adjusts are already true power adjusts.

Capture power levels per 6.4MHz or simply **power adjust** levels per 1.6MHz depending on whether the **base-power-rx-level-1\_6Mhz** is configured.

If **base-power-rx-level-1\_6Mhz** is configured, then per-channel CLI has enhanced help strings for clarification:

```

router(config)#cable upstream controller-profile 499
router(config-controller-profile)#us-channel 0 power-level ?
<-13 - 25> Power level in dBmV-total power in PSD 6.4Mhz if base-power-rx-level-1.6Mhz NOT
        configured(-4~25 for rphy- node, -13~23 for rphy-shelf) [OR] true power adjust
if
        base-power-rx-level-1_6Mhz configured

```

Here **us-channel** indicates Upstream channel configuration and **power-level** indicates Input power level.



**Note** The end-user is responsible for reconfiguring the individual upstream channel power levels as needed if the upstream RF port base power configuration is enabled.

### US RF Port Power CLI - RPD Configuration Level

To configure upstream RF port base power (TLV 98.3) at the RPD level, use the **base-power-rx-level-1\_6Mhz** option under **cable rpd** to enable base power configuration.

```

router(config)#cable rpd node1
router(config-rpd)#identifier aaaa.bbbb.cccc
router(config-rpd)#rpd-us 0 base-power-rx-level-1_6Mhz ?
<-20 - 40> Supported ranges: -10~29 for rphy-node, -25~10 for rphy-shelf(ref
pt:0dBmV/1.6Mhz)

```

The RPD config CLI base power config allows per upstream RF port on that RPD as shown above. This gives you finer control over a specific RPD's upstream port power.

The upstream port base power config can be applied to both rpd configuration block as well as the upstream controller profile as shown earlier. If configured at both levels, the config in the rpd block takes precedence for the given rpd upstream RF port.

The option to configure the base port power config at the profile level, affects all RPDs using that profile; while the configuration at the `cable rpd` level fine tunes the base power configuration only for that upstream port on that RPD. It also takes precedence over the profile configuration for base power if present.



**Note** Configuring the base power using either of the preceding commands, trigger the TLV 98.3 message from CBR8 to RPD and the implementation on RPD changes to reflect new power calculations based on 0dBmV/1.6MHz reference.

### RPD Show Command

The RPD **show vga** CLI can be used to see the details of port power configurations including per port vga settings, per port per channel nb-gain settings, per port TLV 98.3 settings and user configured values.

```

R-PHY#show vga
OOB US S/W VGA Gain:
  Port0: 7
  Port1: -16

OOB US Default Gain Calculated:
  Port0: 7
  Port1: 7

```

```

Enable Upstream Calibration: TRUE

Upstream Calibration - Port0: 6 0 Port1: 6 0
VGA of platform: CSHELF
VGA Setting: Power values below in reference to 0dBmV/6.4Mhz
Port0: 0x23 (-9db)
Port1: 0x10 (+10db)
NB-GAIN Setting:
Port 0 (SCQAM0)
  receiver 0 : 36(0x24) adj:+1.0:+1.1 db
  receiver 1 : 36(0x24) adj:+1.0:+1.1 db
  receiver 2 : 32(0x20) adj:-0.1:+0.1 db
  receiver 3 : 25(0x19) adj:-2.0 db
  receiver 4 : 32(0x20) adj:-0.1:+0.1 db
  receiver 5 : 32(0x20) adj:-0.1:+0.1 db
Port 1 (SCQAM1)
  no scqam receiver configured in port 1
TLV 98.3 Setting:
Supp range for TLV 98.3: -200 to 100 TenthdBmV per 1.6MHz
Port 0 : Enabled
User Config value: 100
Port 1 : Disabled
User Config value: --
OFDMA pwrAdjust Setting:
Port 0
  receiver 0 : 25(0x19) adj:-2.0 db
Port 1
  Value not set as tlv98.3 disabled for this port

```

## US RF Port Power Configuration Examples

### Sample Profile Configuration Block with TLV 98.3 Enabled

The configuration on both the controller profile and rpd block is saved in NVRAM and available on reboot. SUPHA is supported for TLV 98.3. The config under the cable rpd block for an rpd takes precedence over the controller profile config if the upstream base power value is configured under both sections.

```

router(config)#cable upstream controller-profile 499
router(config-controller-profile)#base-power-rx-level-1_6Mhz 10 << US Base target power
level in units of dBmV/1.6MHz (tlv 98.3)
router(config-controller-profile)# us-channel 0 channel-width 3200000 3200000
router(config-controller-profile)# us-channel 0 docsis-mode atdma
router(config-controller-profile)# us-channel 0 power-level 5 << US target rx power adjust
level in units of dBmV/1.6MHz (tlv 65.9)

```

### Sample RPD Configuration Block with Tlv 98.3 Enabled

The base power config for rpd aaaa.bbbb.cccc, based on the following configuration is 50dbmV/1.6Mhz on upstream port 0 while all the other rpds using profile 499 has the base power config on their upstream port 0 to be 10dBmV/1.6Mhz.

```

cable rpd node1
identifier aaaa.bbbb.cccc
rpd-us 0 base-power-rx-level-1_6Mhz 5
core-interface Te8/1/0
rpd-ds 0 downstream-cable 8/0/0 profile 2
rpd-us 0 upstream-cable 8/0/0 profile 499

```

...  
...

### Disabling TLV 98.3

Disabling TLV 98.3 via CLI causes cBR-8 to switch to legacy power implementation with reference to 0dBmV/6.4MHz



**Note** All the RPDs MUST reboot if the 98.3 CLI above is disabled. Disabling TLV 98.3 can be done both at the controller profile as well as cable rpd configuration level. If the RPD is not rebooted post disabling base power config on cbr8, upstream power behavior on RPD is undefined.

#### Controller Profile

```
router(config)#cable upstream controller-profile 499
router(config-controller-profile)#no base-power-rx-level-1_6Mhz
Warning: Upstream RfPort BasePower config removed on ctrlr profile. Please reboot ALL RPDs
associated with this profile manually otherwise the upstream power behavior is undefined
cable rpd configuration level
```

```
router(config)#cable rpd node1
router(config-rpd)#no rpd-us 1 base-power-rx-level-1_6Mhz
Warning: Upstream RfPort BasePower config removed. Please reboot this RPD manually otherwise
the upstream power behavior is undefined
```

Clarifying help strings are used in per-channel upstream power CLI – the onus is on the user to configure the ‘per-channel’ CLI value accordingly. If the user removes the base power that is configured by issuing cli ‘no base-power-rx-level-1\_6Mhz’, the user MUST update the ‘per-channel power level’ to use the appropriate desired value.

#### MIBs Information

| Feature Name                                           | Release Information          | Feature Description                                                                                                                                                                                                                                                                                                                                                                                        |
|--------------------------------------------------------|------------------------------|------------------------------------------------------------------------------------------------------------------------------------------------------------------------------------------------------------------------------------------------------------------------------------------------------------------------------------------------------------------------------------------------------------|
| Received power MIB Update for SCQAM and OFDMA channels | Cisco IOS XE Dublin 17.12.1y | In this release, the received power for all the upstream channels, SCQAM and OFDMA, will be reported in 1.6MHz reference. It will also include an upstream RF port base power if configured (applicable to rphy only). The following MIBs have been updated: <ul style="list-style-type: none"> <li>• <b>DocsIf3CmtsCmUsStatusRxPower</b></li> <li>• <b>docsIf31CmtsCmUsOfdmaChannelRxPower</b></li> </ul> |

In the release Cisco IOS XE Dublin 17.12.1y, on CBR8, the per CM MIB reporting upstream channel received power - docsIf3CmtsCmUsStatusRxPower and docsIf31CmtsCmUsOfdmaChannelRxPower - will now report the received power of the SCQAM and OFDMA upstream channels respectively at 1.6MHz PSD reference per the cable labs specification. This is applicable to all CMs online on both ICMTS and RPHY line cards. Also both the MIBs now also include the base power, if configured on the RPHY upstream RF port along with the per channel power level in the Received Power reporting. The upstream RF port base power feature was introduced for RPHY cards in the IOS-XE 17.9.1y release.

A sample MIB output of upstream received power implementation for the configuration is as specified below for different channel widths for the release Cisco IOS XE Dublin 17.12.1y:

```

CBR8#show cable modem rpd name node2
MAC Address      IP Address      I/F            MAC              Prim  RxPwr  Timing Num I Dev
                IP Address      I/F            State            Sid   (dBmV) Offset CPE P Class
9058.515c.9e3c  9.8.8.64        C8/0/2/UB     w-online(pt)    5     -0.25  1265  0   N CM
cable upstream controller-profile 22
base-power-rx-level-1_6Mhz -6
us-channel 0 channel-width 3200000 3200000
us-channel 0 docsis-mode atdma
us-channel 0 equalization-coefficient
us-channel 0 frequency 11400000
us-channel 0 minislots-size 2
us-channel 0 modulation-profile 223
  no us-channel 0 shutdown
us-channel 1 channel-width 1600000 1600000
us-channel 1 docsis-mode atdma
us-channel 1 equalization-coefficient
us-channel 1 frequency 14600000
us-channel 1 minislots-size 4
us-channel 1 modulation-profile 223
  no us-channel 1 shutdown
us-channel 2 channel-width 6400000 6400000
us-channel 2 docsis-mode atdma
us-channel 2 equalization-coefficient
us-channel 2 frequency 20000000
us-channel 2 minislots-size 1
us-channel 2 modulation-profile 223
  no us-channel 2 shutdown
us-channel 3 channel-width 6400000 6400000
us-channel 3 docsis-mode atdma
us-channel 3 equalization-coefficient
us-channel 3 frequency 32400000
us-channel 3 minislots-size 8
us-channel 3 modulation-profile 223
  us-channel 3 specsvl error-adaptive-profile 3
  no us-channel 3 shutdown
us-channel 4 channel-width 3200000 3200000
us-channel 4 docsis-mode atdma
us-channel 4 frequency 24200000
us-channel 4 minislots-size 2
us-channel 4 modulation-profile 221
  us-channel 4 shutdown
us-channel 5 channel-width 3200000 3200000
us-channel 5 docsis-mode atdma
us-channel 5 frequency 27400000
us-channel 5 minislots-size 2
us-channel 5 modulation-profile 221
  no us-channel 5 shutdown
us-channel 12 docsis-mode ofdma
us-channel 12 subcarrier-spacing 25KHz
us-channel 12 modulation-profile 421
  us-channel 12 frequency-range 40000000 85000000
us-channel 12 cyclic-prefix 128 roll-off-period 32
us-channel 12 symbols-per-frame 9
  no us-channel 12 shutdown

CBR8#show cable modem 9058.515c.9e3c wideband channel
MAC Address      IP Address      I/F            MAC              DSxUS Primary
                IP Address      I/F            State            WB
9058.515c.9e3c  9.8.8.64        C8/0/2/UB     w-online(pt)    9x5   Wi8/0/2:0

CBR8#show cable modem 9058.515c.9e3c verbose | i Received Power

```

```

Received Power Delta (dBmV)      : 0.00      0.00      0.00      0.00
Config Received Power (dBmV@chw) : -3.00     -6.00     0.00     0.00
Received Power (dBmV@chw)       : -3.00     -6.00     0.00     0.00
Config Received Power (dBmV@1.6MHz) : -6.00     -6.00     -6.00     -6.00
Received Power (dBmV@1.6MHz)    : -6.00     -6.00     -6.00     -6.00
Received Power Delta (dBmV)      : -0.25
Config Received Power (dBmV@chw) : 0.00
Received Power (dBmV@chw)       : -0.25
Config Received Power (dBmV@1.6MHz) : -6.00
Received Power (dBmV@1.6MHz)    : -6.25

```

Associated MIB outputs:

```

server > snmpwalk -v2c -c <community_string> <ubr8_ip> docsIf3CmtsCmRegStatusMacAddr | grep
6324229
docsIf3CmtsCmRegStatusMacAddr.6324229 = 90 58 51 5c 9e 3c

```

SCQAM:

```

lwr-lnx-util-1:~ > snmpwalk -v 2c -c public 2.29.1.1 1.3.6.1.4.1.4491.2.1.20.1.4.1.3 |
more
SNMPv2-SMI::enterprises.4491.2.1.20.1.4.1.3.4718593.494952 = INTEGER: -60
SNMPv2-SMI::enterprises.4491.2.1.20.1.4.1.3.4718593.494953 = INTEGER: -60
SNMPv2-SMI::enterprises.4491.2.1.20.1.4.1.3.4718593.494954 = INTEGER: -60
SNMPv2-SMI::enterprises.4491.2.1.20.1.4.1.3.4718595.494952 = INTEGER: -60
OFDMA: (Actual + config Received Power)
lwr-lnx-util-1:~ > snmpwalk -v 2c -c public 2.29.1.1 1.3.6.1.4.1.4491.2.1.28.1.4.1.1
SNMPv2-SMI::enterprises.4491.2.1.28.1.4.1.1.4718593.494955 = INTEGER: -62
SNMPv2-SMI::enterprises.4491.2.1.28.1.4.1.1.4718594.494955 = INTEGER: -60

```

### Upstream Per-Channel TLVs

For the per-channel upstream power config, it captures either the total absolute power levels per 6.4MHz or true power adjust levels depending on whether the upstream base power command `base-power-rx-level-1_6Mhz` is configured. The per-channel command has enhanced help strings to display the changes if `base-power-rx-level-1_6Mhz` is configured.

```

Router (config-controller-profile)#us-channel 0 power-level ?
<-13 - 25> Power level in dBmV-total power in PSD 6.4Mhz if base-power-rx-level-1.6Mhz
NOT
        configured(-4~25 for rphy- node, -13~23 for rphy-shelf) [OR] true power adjust
        if
                base-power-rx-level-1_6Mhz configured

```

### Configuration With SC-QAM Upstream Channel

```

router(config)#cable upstream controller-profile 499
router(config-controller-profile)#base-power-rx-level-1_6Mhz 10
router(config-controller-profile)# us-channel 0 channel-width 3200000 3200000
router(config-controller-profile)# us-channel 0 docsis-mode atdma
router(config-controller-profile)# us-channel 0 power-level 5

```

Here `us-channel 0 power-level 5` indicates US target rx power adjust level - true power adjust with above upstream base power config(TLV 65.9).

For the per-channel upstream power config, if the base port power level is configured via TLV 98.3, the channel adjusts automatically become true channel adjusts in Cisco 1x2 RPD. You must reconfigure the per-channel power adjust if needed by taking the new port base power configuration into consideration.



## NVGEN For cBR-8

All the upstream RF port base power configurations are nv-generated. The base power configuration is available in `show running-configuration` once you enable it. The default configuration for the CBR8 is the `no` version of the base power command for the TLV 98.3. If you do not enable the feature or explicitly disable the feature, then the default configuration can be verified by using the `no` version of this feature in `show running-config all`.

For example, with no base power config on the upstream RF port, see the following sample outputs for the `show run` and the `show run all`:

```
Router#show run all | sec cable upstream controller-profile 3
cable upstream controller-profile 3
  description Cox-upstream-prof-eg
  no base-power-rx-level-1_6Mhz
cable def-phy-burst 0
  us-channel 0 chan-class-id 7
  us-channel 0 channel-width 6400000 6400000
<<!snip>
Router#show run | sec cable upstream controller-profile 3
cable upstream controller-profile 3
  description Cox-upstream-prof-eg
  us-channel 0 chan-class-id 7
  us-channel 0 channel-width 6400000 6400000
  us-channel 0 docsis-mode atdma
  us-channel 0 equalization-coefficient
<<!snip>
```

```
Router#show run | sec node1
cable rpd node1
  description TB17-RPD2-3 HWaddr F4:DB:E6:FE:CC:E2
  identifier aaaa.bbbb.cccc
  core-interface Hu9/1/8
  principal
  rpd-ds 0 downstream-cable 9/0/4 profile 25
  rpd-us 0 upstream-cable 9/0/4 profile 3
  rpd-us 1 upstream-cable 9/0/5 profile 3
  r-dti 1
  rpd-event profile 0
  rpd-55d1-us-event profile 0
```

## Sample CLI Configuration with TLV 98.3 for 0dBmV/6.4MHz

The following table shows examples of setting up the CLI to configure total absolute power level of 0dBmV/6.4Mhz (current Cisco implementation) using the new CLI for base power config and corresponding TLV 98.3 sent to RPD. The first row in the table above refer to CMTS and RPHY release versions which support TLV 98.3 and the older versions refer to releases which do not have TLV 98.3 support. The example above shows the configuration for the current implementation of **0dBmV/6.4MHz for a 1.6-MHz channel**. This shows how the configured TLV values on the CLI is interpreted and sent to RPD which supports TLV 98.3 for different versions of CBR8.

Table 177:

| Cisco IOS XE Version                           | CLI configuration on cBR-8                                                                                                                                                                                                                                                | TLV 98.3 and TLV 65.9 sent to RPD              | Description                                                                                                                                                                                                                   |
|------------------------------------------------|---------------------------------------------------------------------------------------------------------------------------------------------------------------------------------------------------------------------------------------------------------------------------|------------------------------------------------|-------------------------------------------------------------------------------------------------------------------------------------------------------------------------------------------------------------------------------|
| Cisco IOS XE Cupertino 17.9.1w and later       | <pre>router(config)#cable upstream controller-profile 499 router(config-controller-profile)#base-power-rx-level-1_6Mhz -6 router(config-controller-profile)#us-channel 0 channel-width 1600000 1600000 router(config-controller-profile)#us-channel 0 power-level 0</pre> | <pre>TLV 98.3 -&gt; -60 TLV 65.9 -&gt; 0</pre> | The base power value of -6 dbmV per 1.6Mhz translates to 0 dbmV per 6.4Mhz and the channel power adjusts are true power adjusts now. This config on BOTH RPD and CBR8 are aligned with cable lab spec power level definition. |
| Releases before Cisco IOS XE Cupertino 17.9.1w | <pre>router(config)#cable upstream controller-profile 499 router(config-controller-profile)#us-channel 0 channel-width 1600000 1600000 router(config-controller-profile)#us-channel 0 power-level 0</pre>                                                                 | <pre>TLV 65.9 -&gt; 0</pre>                    | This Cisco IOS XE version does not support TLV 98.3, so cBR-8 and Cisco rpd config are aligned with current legacy implementation.                                                                                            |

## Feature Information for Controller Profile Configuration

Use Cisco Feature Navigator to find information about the platform support and software image support. Cisco Feature Navigator enables you to determine which software images support a specific software release, feature set, or platform. To access Cisco Feature Navigator, go to the <https://cfng.cisco.com/> link. An account on the Cisco.com page is not required.



**Note** The following table lists the software release in which a given feature is introduced. Unless noted otherwise, subsequent releases of that software release train also support that feature.

Table 178: Feature Information for Controller Profile Configuration

| Feature Name                     | Releases                 | Feature Information                                                                                          |
|----------------------------------|--------------------------|--------------------------------------------------------------------------------------------------------------|
| SG Based Config (OpSimp) Phase 2 | Cisco IOS XE Fuji 16.7.1 | This feature was introduced on Cisco IOS XE Fuji 16.7.1 on the Cisco cBR Series Converged Broadband Routers. |



## CHAPTER 47

# Voltage Thresholds for AC Power Supply Module Mode Control

---

This document describes how to configure the voltage thresholds for switching modes in AC Power SupplyModule (PSM).

Your software release may not support all the features that are documented in this module. For the latest feature information and caveats, see the release notes for your platform and software release. The Feature Information Table at the end of this document provides information about the documented features and lists the releases in which each feature is supported.

Use Cisco Feature Navigator to find information about platform support and Cisco software image support. To access Cisco Feature Navigator, go to <http://tools.cisco.com/ITDIT/CFN/>. An account on <http://www.cisco.com/> is not required.

- [Hardware Compatibility Matrix for the Cisco cBR Series Routers, on page 839](#)
- [Information about Voltage Thresholds for AC PSM Mode Control, on page 841](#)
- [How to Configure Voltage Thresholds for AC PSM Mode Control, on page 841](#)
- [Configuration Examples, on page 842](#)
- [Feature Information for Voltage Thresholds for AC PSM Mode Control, on page 842](#)

## Hardware Compatibility Matrix for the Cisco cBR Series Routers



---

**Note** The hardware components that are introduced in a given Cisco IOS-XE Release are supported in all subsequent releases unless otherwise specified.

---

Table 179: Hardware Compatibility Matrix for the Cisco cBR Series Routers

| Cisco CMTS Platform                    | Processor Engine                                                                                                                                                                                  | Interface Cards                                                                                                                                                                                                                                                                                                                                                                                                                                                                                                                                                                                                                                                                                                                                                                                 |
|----------------------------------------|---------------------------------------------------------------------------------------------------------------------------------------------------------------------------------------------------|-------------------------------------------------------------------------------------------------------------------------------------------------------------------------------------------------------------------------------------------------------------------------------------------------------------------------------------------------------------------------------------------------------------------------------------------------------------------------------------------------------------------------------------------------------------------------------------------------------------------------------------------------------------------------------------------------------------------------------------------------------------------------------------------------|
| Cisco cBR-8 Converged Broadband Router | <p><b>Cisco IOS-XE Release 16.5.1 and Later Releases</b></p> <p>Cisco cBR-8 Supervisor:</p> <ul style="list-style-type: none"> <li>• PID—CBR-SUP-250G</li> <li>• PID—CBR-CCAP-SUP-160G</li> </ul> | <p><b>Cisco IOS-XE Release 16.5.1 and Later Releases</b></p> <p>Cisco cBR-8 CCAP Line Cards:</p> <ul style="list-style-type: none"> <li>• PID—CBR-LC-8D30-16U30</li> <li>• PID—CBR-LC-8D31-16U30</li> <li>• PID—CBR-RF-PIC</li> <li>• PID—CBR-RF-PROT-PIC</li> <li>• PID—CBR-CCAP-LC-40G</li> <li>• PID—CBR-CCAP-LC-40G-R</li> <li>• PID—CBR-CCAP-LC-G2-R</li> <li>• PID—CBR-SUP-8X10G-PIC</li> <li>• PID—CBR-2X100G-PIC</li> </ul> <p>Digital PICs:</p> <ul style="list-style-type: none"> <li>• PID—CBR-DPIC-8X10G</li> <li>• PID—CBR-DPIC-2X100G</li> </ul> <p>Cisco cBR-8 Downstream PHY Module:</p> <ul style="list-style-type: none"> <li>• PID—CBR-D31-DS-MOD</li> </ul> <p>Cisco cBR-8 Upstream PHY Modules:</p> <ul style="list-style-type: none"> <li>• PID—CBR-D31-US-MOD</li> </ul> |



**Note** Do not use DPICs (8X10G and 2x100G) to forward IP traffic, as it may cause buffer exhaustion, leading to line card reload.

The only allowed traffic on a DPIC interface is DEPI, UEPI, and GCP traffic from the Cisco cBR-8 router to Remote PHY devices. Other traffic such as DHCP, SSH, and UTSC should flow via another router, since DPICs cannot be used for normal routing.

# Information about Voltage Thresholds for AC PSM Mode Control

Configuring voltage thresholds help switch between different modes when power budget provided by AC PSMs is not sufficient to power Field Replaceable Units (FRUs).

## Overview of Voltage Thresholds for AC PSM Mode Control

The AC PSM can operate in either 120V or 220V mode.

When the input voltage is between 70V and 197V, the PSM operates in the 120V mode with 1300W power capacity. When input voltage drops below 85V, the PSM powers down completely and its power capacity becomes 0W.

When the input voltage is greater than 197V, the PSM operates in the 220V mode with 3000W power capacity. When input voltage drops below 190V, the PSM switches to the 120V mode and its power capacity decreases to 1300W.

To allow users configure mode switching, two new hysteresis thresholds `Voff_3000W` and `Von_3000W` have been provided. The hysteresis thresholds define when the PSM should switch modes and can be configured using CLI commands.

For example, if `Voff_3000W` is configured as 180V, the PSM switches to the 120V mode with 1300W capacity when input voltage drops below 180V. If `Von_3000W` is configured as 200V, the PSM switches to the 220V mode when input voltage increases to more than 200V.

**Table 180: Voltage Thresholds for Mode Control**

| Threshold               | Default Value | Configurable Range                                                                                                                                         |
|-------------------------|---------------|------------------------------------------------------------------------------------------------------------------------------------------------------------|
| <code>Voff_3000W</code> | 190V          | The value of <code>Voff_3000W</code> can be 170V or greater.                                                                                               |
| <code>Von_3000W</code>  | 197V          | The value of <code>Von_3000W</code> can be 200V or lesser.<br>The value of <code>Voff_3000W</code> must be less than the value of <code>Von_3000W</code> . |

# How to Configure Voltage Thresholds for AC PSM Mode Control

## Configuring Voltage Thresholds for AC PSM Mode Control

To configure voltage thresholds, run the `platform power protection ac220v voff von` command as shown below:

```
Router# configure terminal
platform power protection ac220v voff von
```

To use the default voltage thresholds, run the `no platform power protection ac220v` command as shown below:

```
Router# configure terminal
no platform power protection ac220v
```



---

**Note** By default, power protection action is disabled to avoid service outage. If protection action is disabled, any online FRU is not powered down in the event of insufficient power budget, but any newly installed line card is not powered up.

---

To enable the power protection action, run the **platform power protection action shutdown linecard** command:

```
Router# configure terminal
platform power protection action shutdown linecard
```

## Verifying Voltage Thresholds for AC PSM Mode Control

To verify the voltage thresholds configuration, use the **sh run** command as shown in the example below:

```
Router# configure terminal
Router (config)# sh run | i protection
platform power protection ac220v 180 200
```

## Configuration Examples

This section provides configuration examples for the voltage threshold feature.

### Example: Configuring Voltage Thresholds for AC PSM Mode Control

The following example shows how to configure voltage thresholds:

```
Router# configure terminal
platform power protection ac220v 180 200
```

The following example shows how to disable DPS:

```
Router# configure terminal
no platform power protection ac220v
```

## Feature Information for Voltage Thresholds for AC PSM Mode Control

Use Cisco Feature Navigator to find information about the platform support and software image support. Cisco Feature Navigator enables you to determine which software images support a specific software release, feature set, or platform. To access Cisco Feature Navigator, go to the <https://cfng.cisco.com/> link. An account on the Cisco.com page is not required.



---

**Note** The following table lists the software release in which a given feature is introduced. Unless noted otherwise, subsequent releases of that software release train also support that feature.

---

*Table 181: Feature Information for Voltage Thresholds for AC PSM Mode Control*

| <b>Feature Name</b>                        | <b>Releases</b>          | <b>Feature Information</b>                                                                                   |
|--------------------------------------------|--------------------------|--------------------------------------------------------------------------------------------------------------|
| Voltage Thresholds for AC PSM Mode Control | Cisco IOS XE Fuji 16.7.1 | This feature was introduced in Cisco IOS XE Fuji 16.7.1 on the Cisco cBR Series Converged Broadband Routers. |







## CHAPTER 48

# DOCSIS3.1 Downstream Zero Bit Loading

---

This document describes how to configure DOCSIS3.1 Downstream Zero Bit Loading on the Cisco cBR Series Converged Broadband Router.

- [Hardware Compatibility Matrix for the Cisco cBR Series Routers, on page 845](#)
- [Information about DOCSIS3.1 Downstream Zero Bit Loading, on page 847](#)
- [How to Configure DOCSIS3.1 Downstream Zero Bit Loading, on page 847](#)
- [Feature Information for DOCSIS3.1 Downstream Zero Bit Loading, on page 849](#)

## Hardware Compatibility Matrix for the Cisco cBR Series Routers



---

**Note** The hardware components that are introduced in a given Cisco IOS-XE Release are supported in all subsequent releases unless otherwise specified.

---

Table 182: Hardware Compatibility Matrix for the Cisco cBR Series Routers

| Cisco CMTS Platform                    | Processor Engine                                                                                                                                                                                  | Interface Cards                                                                                                                                                                                                                                                                                                                                                                                                                                                                                                                                                                                                                                                                                                                                                                                 |
|----------------------------------------|---------------------------------------------------------------------------------------------------------------------------------------------------------------------------------------------------|-------------------------------------------------------------------------------------------------------------------------------------------------------------------------------------------------------------------------------------------------------------------------------------------------------------------------------------------------------------------------------------------------------------------------------------------------------------------------------------------------------------------------------------------------------------------------------------------------------------------------------------------------------------------------------------------------------------------------------------------------------------------------------------------------|
| Cisco cBR-8 Converged Broadband Router | <p><b>Cisco IOS-XE Release 16.5.1 and Later Releases</b></p> <p>Cisco cBR-8 Supervisor:</p> <ul style="list-style-type: none"> <li>• PID—CBR-SUP-250G</li> <li>• PID—CBR-CCAP-SUP-160G</li> </ul> | <p><b>Cisco IOS-XE Release 16.5.1 and Later Releases</b></p> <p>Cisco cBR-8 CCAP Line Cards:</p> <ul style="list-style-type: none"> <li>• PID—CBR-LC-8D30-16U30</li> <li>• PID—CBR-LC-8D31-16U30</li> <li>• PID—CBR-RF-PIC</li> <li>• PID—CBR-RF-PROT-PIC</li> <li>• PID—CBR-CCAP-LC-40G</li> <li>• PID—CBR-CCAP-LC-40G-R</li> <li>• PID—CBR-CCAP-LC-G2-R</li> <li>• PID—CBR-SUP-8X10G-PIC</li> <li>• PID—CBR-2X100G-PIC</li> </ul> <p>Digital PICs:</p> <ul style="list-style-type: none"> <li>• PID—CBR-DPIC-8X10G</li> <li>• PID—CBR-DPIC-2X100G</li> </ul> <p>Cisco cBR-8 Downstream PHY Module:</p> <ul style="list-style-type: none"> <li>• PID—CBR-D31-DS-MOD</li> </ul> <p>Cisco cBR-8 Upstream PHY Modules:</p> <ul style="list-style-type: none"> <li>• PID—CBR-D31-US-MOD</li> </ul> |



**Note** Do not use DPICs (8X10G and 2x100G) to forward IP traffic, as it may cause buffer exhaustion, leading to line card reload.

The only allowed traffic on a DPIC interface is DEPI, UEPI, and GCP traffic from the Cisco cBR-8 router to Remote PHY devices. Other traffic such as DHCP, SSH, and UTSC should flow via another router, since DPICs cannot be used for normal routing.

# Information about DOCSIS3.1 Downstream Zero Bit Loading

Zero Bit Loading (ZBL) is a subcarrier in an OFDM channel, it has power but does not carry any user data. ZBL can be used if the user wants to bypass one or more subcarrier because, for example, cable modem reports that Modulation Error Ratio (MER) is too low on these subcarriers.

Unlike the excluded subcarrier which is defined per RF port and applied to all modulation profiles used on that port's OFDM channels, ZBL is defined per profile and applied to individual OFDM channel.

ZBL is modulated using PRBS (Pseudo Randomness Binary Sequence), it can not be used for other purpose. Excluded subcarrier is not modulated, and does not have power, so it can be used for other purposes, such as video.

For more information about the OFDM, see [DOCSIS 3.1 OFDM Channel Configuration, on page 587](#).

## How to Configure DOCSIS3.1 Downstream Zero Bit Loading

### Configuring Downstream Zero Bit Loading

To configure downstream ZBL, follow these steps:

1. Configure ZBL for the data/control profile and the NCP profile.
2. Apply the modulation profiles to a channel profile.
3. Apply the channel profile to an OFDM channel.

Run the following commands as an example to configure ZBL:

```
Router# configure terminal
Router(config)# cable downstream ofdm-modulation-profile 159
Router(config-ofdm-mod-prof)# description an example of ZBL starting at 10MHZ for 1MHZ
Router(config-ofdm-mod-prof)# subcarrier-spacing 50KHZ
Router(config-ofdm-mod-prof)# width 96000000
Router(config-ofdm-mod-prof)# assign modulation-default 1024-QAM
Router(config-ofdm-mod-prof)# assign modulation zero-bit-load range-subcarriers freq-offset
10000000 width 1000000
```

```
Router# configure terminal
Router(config)# cable downstream ofdm-modulation-profile 160
Router(config-ofdm-mod-prof)# description an example for ZBL on NCP profile for one SC
starting 14MHZ
Router(config-ofdm-mod-prof)# subcarrier-spacing 50KHZ
Router(config-ofdm-mod-prof)# width 96000000
Router(config-ofdm-mod-prof)# assign modulation-default 16-QAM
Router(config-ofdm-mod-prof)# assign modulation zero-bit-load list-subcarriers freq-offset
14000000
```

```
Router# configure terminal
Router(config)# cable downstream ofdm-chan-profile 159
Router(config-ofdm-chan-prof)# cyclic-prefix 1024
Router(config-ofdm-chan-prof)# interleaver-depth 16
Router(config-ofdm-chan-prof)# pilot-scaling 48
```

```

Router(config-ofdm-chan-prof)# roll-off 128
Router(config-ofdm-chan-prof)# subcarrier-spacing 50KHZ
Router(config-ofdm-chan-prof)# profile-control modulation-profile 159
Router(config-ofdm-chan-prof)# profile-ncp modulation-profile 160

Router# configure terminal
Router(config)# controller Integrated-Cable 1/0/0
Router(config-controller)# max-ofdm-spectrum 192000000
Router(config-controller)# max-carrier 32
Router(config-controller)# base-channel-power 37
Router(config-controller)# rf-chan 0 3
Router(config-rf-chan)# type DOCSIS
Router(config-rf-chan)# frequency 261000000
Router(config-rf-chan)# rf-output NORMAL
Router(config-rf-chan)# power-adjust 0.0
Router(config-rf-chan)# qam-profile 1
Router(config-rf-chan)# docsis-channel-id 1
Router(config-rf-chan)# exit
Router(config-controller)# rf-chan 158
Router(config-rf-chan)# power-adjust 0.0
Router(config-rf-chan)# docsis-channel-id 159
Router(config-rf-chan)# ofdm channel-profile 159 start-frequency 627000000 width 96000000
plc 648000000

```

## Verifying Downstream Zero Bit Loading

To check if the ZBL is taking effect, use **show controllers verbose** command as shown in the example below:

```

router# show controllers integrated-Cable 1/0/0 rf-channel 158 verbose | in ZBL
1024 :634350000[1235] - 636950000[1287]      ZBL :637000000[1288] - 637850000[1305]
      ZBL :637950000[1307] - 637950000[1307]      1024 :638000000[1308] - 641450000[1377]
Active subcarrier count: 1804, ZBL count: 19
      ZBL :641000000[1368] - 641000000[1368]      16 :641050000[1369] - 641450000[1377]
Active subcarrier count: 1804, ZBL count: 1

```

User can also check DPD messages as shown in the example below:

```

router# show cable mac-domain c1/0/0 dpd integrated-Cable 1/0/0 158
DPD Message
  MAC Header
    Frame Control           : 0xC2      (MAC specific, MAC msg, EHDR Off)
    MAC Parameters          : 0x0
    Length                  : 41
    Header Check Sequence   : 0xB242 (45634)
  MAC Management Header
    Destination MAC ADDR    : 01e0.2f00.0001
    Source MAC ADDR         : d42c.447c.2ce9
    Length                  : 23
    Destination SAP         : 0
    Source SAP              : 0
    Control                 : 3
    Version                 : 5
    Type                    : 50
    Multipart               : 0      (Sequence number 0, Fragments 0)
  DPD fields
    DCID                    : 159
    Profile ID              : 0
    CCC                     : 4
    TLV 5 Subcarrier Range/List : Range (continuous)
      Modulation             : 1024 (default value)
      : 0000 - 4095
    TLV 5 Subcarrier Range/List : Range (continuous)

```

```

Modulation                : Zero
                          : 1288 - 1307
DPD Message
MAC Header
  Frame Control            : 0xC2    (MAC specific, MAC msg, EHDR Off)
  MAC Parameters           : 0x0
  Length                   : 39
  Header Check Sequence   : 0xCCAB (52395)
MAC Management Header
  Destination MAC ADDR    : 01e0.2f00.0001
  Source MAC ADDR        : d42c.447c.2ce9
  Length                  : 21
  Destination SAP        : 0
  Source SAP              : 0
  Control                 : 3
  Version                 : 5
  Type                    : 50
  Multipart               : 0      (Sequence number 0, Fragments 0)
DPD fields
  DCID                    : 159
  Profile ID              : 255
  CCC                     : 4
  TLV 5 Subcarrier Range/List
    Modulation             : Range (continuous)
                          : 16 (default value)
                          : 0000 - 4095
  TLV 5 Subcarrier Range/List
    Modulation             : List
                          : Zero
                          : 1368

```

## Feature Information for DOCSIS3.1 Downstream Zero Bit Loading

Use Cisco Feature Navigator to find information about the platform support and software image support. Cisco Feature Navigator enables you to determine which software images support a specific software release, feature set, or platform. To access Cisco Feature Navigator, go to the <https://cfng.cisco.com/> link. An account on the Cisco.com page is not required.



**Note** The following table lists the software release in which a given feature is introduced. Unless noted otherwise, subsequent releases of that software release train also support that feature.

**Table 183: Feature Information for DOCSIS3.1 Downstream Zero Bit Loading**

| Feature Name                          | Releases                 | Feature Information                                                                |
|---------------------------------------|--------------------------|------------------------------------------------------------------------------------|
| DOCSIS3.1 Downstream Zero Bit Loading | Cisco IOS XE Fuji 16.8.1 | This feature was introduced into the Cisco cBR Series Converged Broadband Routers. |





## CHAPTER 49

# Reducing Power Consumption

---

This document describes how to reduce power consumption on the Cisco cBR Series Converged Broadband Router.

Your software release may not support all the features that are documented in this module. For the latest feature information and caveats, see the release notes for your platform and software release. The Feature Information Table at the end of this document provides information about the documented features and lists the releases in which each feature is supported.

Use Cisco Feature Navigator to find information about platform support and Cisco software image support. To access Cisco Feature Navigator, go to <http://tools.cisco.com/ITDIT/CFN/>. An account on <http://www.cisco.com/> is not required.

- [Finding Feature Information, on page 851](#)
- [Hardware Compatibility Matrix for the Cisco cBR Series Routers, on page 851](#)
- [Information About Reducing Power Consumption, on page 853](#)
- [Configure Reduction of Power Consumption, on page 853](#)
- [Feature Information for Reducing Power Consumption , on page 854](#)

## Finding Feature Information

Your software release may not support all the features that are documented in this module. For the latest feature information and caveats, see the release notes for your platform and software release. The Feature Information Table at the end of this document provides information about the documented features and lists the releases in which each feature is supported.

Use Cisco Feature Navigator to find information about platform support and Cisco software image support. To access Cisco Feature Navigator, go to <http://tools.cisco.com/ITDIT/CFN/>. An account on <http://www.cisco.com/> is not required.

## Hardware Compatibility Matrix for the Cisco cBR Series Routers



---

**Note** The hardware components that are introduced in a given Cisco IOS-XE Release are supported in all subsequent releases unless otherwise specified.

---

Table 184: Hardware Compatibility Matrix for the Cisco cBR Series Routers

| Cisco CMTS Platform                    | Processor Engine                                                                                                                                                                                  | Interface Cards                                                                                                                                                                                                                                                                                                                                                                                                                                                                                                                                                                                                                                                                                                                                                                                 |
|----------------------------------------|---------------------------------------------------------------------------------------------------------------------------------------------------------------------------------------------------|-------------------------------------------------------------------------------------------------------------------------------------------------------------------------------------------------------------------------------------------------------------------------------------------------------------------------------------------------------------------------------------------------------------------------------------------------------------------------------------------------------------------------------------------------------------------------------------------------------------------------------------------------------------------------------------------------------------------------------------------------------------------------------------------------|
| Cisco cBR-8 Converged Broadband Router | <p><b>Cisco IOS-XE Release 16.5.1 and Later Releases</b></p> <p>Cisco cBR-8 Supervisor:</p> <ul style="list-style-type: none"> <li>• PID—CBR-SUP-250G</li> <li>• PID—CBR-CCAP-SUP-160G</li> </ul> | <p><b>Cisco IOS-XE Release 16.5.1 and Later Releases</b></p> <p>Cisco cBR-8 CCAP Line Cards:</p> <ul style="list-style-type: none"> <li>• PID—CBR-LC-8D30-16U30</li> <li>• PID—CBR-LC-8D31-16U30</li> <li>• PID—CBR-RF-PIC</li> <li>• PID—CBR-RF-PROT-PIC</li> <li>• PID—CBR-CCAP-LC-40G</li> <li>• PID—CBR-CCAP-LC-40G-R</li> <li>• PID—CBR-CCAP-LC-G2-R</li> <li>• PID—CBR-SUP-8X10G-PIC</li> <li>• PID—CBR-2X100G-PIC</li> </ul> <p>Digital PICs:</p> <ul style="list-style-type: none"> <li>• PID—CBR-DPIC-8X10G</li> <li>• PID—CBR-DPIC-2X100G</li> </ul> <p>Cisco cBR-8 Downstream PHY Module:</p> <ul style="list-style-type: none"> <li>• PID—CBR-D31-DS-MOD</li> </ul> <p>Cisco cBR-8 Upstream PHY Modules:</p> <ul style="list-style-type: none"> <li>• PID—CBR-D31-US-MOD</li> </ul> |



**Note** Do not use DPICs (8X10G and 2x100G) to forward IP traffic, as it may cause buffer exhaustion, leading to line card reload.

The only allowed traffic on a DPIC interface is DEPI, UEPI, and GCP traffic from the Cisco cBR-8 router to Remote PHY devices. Other traffic such as DHCP, SSH, and UTSC should flow via another router, since DPICs cannot be used for normal routing.



## Information About Reducing Power Consumption

A Cisco cBR-8 CCAP line card has two downstream PHY modules. The first downstream PHY module has port number 0 through port number 3. The second downstream PHY module has port number 4 through port number 7. Each downstream PHY module consumes approximately 70W of power even if no RF channels are used. By default, both downstream PHY modules are powered up.

To reduce power consumption in the Cisco cBR-8, you can power down the second downstream PHY module.

The power-saving configuration is retained for supervisor card reload, supervisor high availability, LCHA, and LCPR configurations.

## Restrictions for Setting Up Power-Saving Configuration

The following restrictions are applicable for setting up power-saving configuration:

- Before powering down the second downstream PHY module, you must shut down the downstream controllers.
- You cannot power down the downstream PHY module on a redundant line card.
- The redundant line card must be in the hot standby mode.

## Configure Reduction of Power Consumption

Before powering down the second downstream PHY module, you must shut down the downstream controllers.

To shut down downstream controllers 4 to 7, run the following commands:

```
Router# enable
Router# configure terminal
Router(config)# controller integrated-Cable slot/subslot/port
Router (config-controller)# shutdown
```

The following example shows how to shut down downstream controllers 4 to 7.

```
Router# enable
Router# configure terminal
Router(config)# controller integrated-Cable 1/0/4
Router (config-controller)# shutdown
```

To power down the second downstream PHY module, run the following commands:

```
Router# enable
Router# configure terminal
Router(config)# cable downstream power-down-2nd-module slot
```

The following example shows how to power down the PHY module in slot 1.

```
Router# enable
Router# configure terminal
Router(config)# cable downstream power-down-2nd-module slot 1
```

## Verifying the Power-Saving Configuration

After powering down the second downstream PHY module, the power consumption in downstream controllers 4 to 7 changes to 0.

To check power consumption in downstream controllers 4 to 7, run the following command:

```
Router# show cable card 1/0 ds-phy display | include Watts
```

```
Port0-3 Power Consumption 82781 (mWatts), Port4-7 Power Consumption 53443 (mWatts)
```

To check power consumption in downstream controllers 4 to 7 after powering down the downstream PHY module, run the following command.

```
Router# show cable card 1/0 ds-phy display | include Watts
```

```
Port0-3 Power Consumption 82781 (mWatts), Port4-7 Power Consumption 0 (mWatts)
```

The second downstream PHY module information shows *Powered down to save energy* when the **show cable card slot/sub-slot ds-phy display | include detected** command is run.

## Feature Information for Reducing Power Consumption

Use Cisco Feature Navigator to find information about the platform support and software image support. Cisco Feature Navigator enables you to determine which software images support a specific software release, feature set, or platform. To access Cisco Feature Navigator, go to the <https://cfng.cisco.com/> link. An account on the Cisco.com page is not required.



**Note** The following table lists the software release in which a given feature is introduced. Unless noted otherwise, subsequent releases of that software release train also support that feature.

**Table 185: Feature Information for Reducing Power Consumption**

| Feature Name               | Releases                  | Feature Information                                                                                          |
|----------------------------|---------------------------|--------------------------------------------------------------------------------------------------------------|
| Reducing Power Consumption | Cisco IOS XE Fuji 16.9.1a | This feature was introduced in Cisco IOS XE Fuji 16.9.1 on the Cisco cBR Series Converged Broadband Routers. |



## CHAPTER 50

# Low Latency DOCSIS

This document describes how to configure Low Latency DOCSIS (LLD) on the Cisco cBR Series Converged Broadband Router.

### Overview

Cablelabs introduced Low Latency DOCSIS technology (LLD) in DOCSIS 3.1 to further reduce latency for applications that are sensitive to delays. LLD technology uses separate service flows, Classic Service Flow and Low Latency Service Flow (LL SF), for traffic that may cause queue building (QB, for example, TCP CUBIC) and traffic that does not cause queue building (NQB, for example gaming, L4S).

- [Active Queue Management, on page 855](#)
- [Aggregate Service Flow, on page 860](#)
- [Latency Histogram, on page 863](#)
- [Enabling Packet Classification for DOCSIS Compliance, on page 871](#)

## Active Queue Management

Table 186: Feature History

| Feature Name                             | Release Information            | Feature Description                                                                                                                                                                                                                                                                      |
|------------------------------------------|--------------------------------|------------------------------------------------------------------------------------------------------------------------------------------------------------------------------------------------------------------------------------------------------------------------------------------|
| Updates for Active Queue Management(AQM) | Cisco IOS XE Dublin 17.12.1    | In this release, AQM is updated to include Immediate AQM, where Explicit Congestion Notification can be sent to the sender to control the latency of the queue. Also included in 17.12.1 is queue coupling, which ensures fairness between the classic and low-latency queues in an ASF. |
| Support for Active Queue Management(AQM) | Cisco IOS XE Cupertino 17.9.1y | Active Queue Management (AQM) is one of the critical components of LLD. AQM allows routers to control the queue length and delay of packets.                                                                                                                                             |

Active Queue Management (AQM) is one of the critical components of Low-Latency DOCSIS (LLD). AQM allows routers to control the queue length and delay of packets.

Traditional Queue Management can lead to tail dropping when the queue is full. By dropping packets before buffer overflow, AQM allows routers to control the queue length and delay of packets.

### Benefits of AQM

AQM Reduces buffer bloat and traffic latency while also improving the user experience.

cBR-8 implements the PIE algorithm as defined in RFC 8033 as the downstream AQM algorithm.

### PIE Algorithm

Proportional Integral Controller Enhanced (PIE) controls latency by randomly dropping packets when latency is approaching or exceeding the latency target. PIE is the AQM algorithm that is implemented on the cBR-8.

### Explicit Congestion Notification (ECN) Marking

If packets are classified to Low Latency Service Flow (LL SF) and marked by the sender as ECN Capable Transport (ECT1), The CMTS may mark the Congestion Experienced bit (CE), if the queue starts to build up.

Low Latency Low Loss Scalable Throughput (L4S) is a new technology that relies on ECN to provide high throughput and low latency for IP traffic. Examples of L4S congestion control algorithms are TCP Prague, Google BBR/BBR2, and Apple QUIC.

### Immediate AQM (IAQM)

L4S technology requires network equipment to apply ECN marking more frequently than classic ECN marking or dropping Immediate AQM (IAQM) algorithm is used by Low Latency Service Flows (LL SF) to determine the marking probability. IAQM uses a ramp function to calculate marking probability, probNative, based on Minimum threshold, Maximum threshold and current queue delay. The Minimum threshold and Maximum threshold can be configured via TLVs or service classes.

### Dual-Queue Coupled AQM

With the coexistence of Queue-Building (QB) traffic (which will be placed on a classic Service Flow) and Non-Queue-Building (NQB) traffic, the Low Latency Service Flow (LL SF) implements Congestion Experienced (CE) marking, while the Classic SF AQM uses packet drops.

The coupling between the AQMs ensures that the capacity of the aggregate service flow is used roughly equally by traffic flows across both LL SF and Classic SF, that is, a traffic flow would get approximately the same bandwidth, regardless of which service flow it is on.

### AQM Parameters

*Table 187: SF AQM Disable*

| Type    | Length | Value                                                             |
|---------|--------|-------------------------------------------------------------------|
| 25.40.1 | 1      | 0 = Enable AQM on service flow<br>1 = Disable AQM on service flow |

**Table 188: Downstream Classic AQM Latency Target**

| Type    | Length | Value                                |
|---------|--------|--------------------------------------|
| 25.40.2 | 1      | AQM Latency Target (in milliseconds) |

Recommended Latency Target Range: 10ms - 100ms

#### Configure Latency Target with service class:

```
cable service class 300 downstream
cable service class 300 aqm-disable 0
cable service class 300 aqm-latency-target 15
```

#### IAQM Ramp Function Parameters

Immediate AQM Max Threshold:

```
Type          Length Value
[24/25].40.4 2      Maximum threshold of the ramp function (in us)
```

Default: 1000 us

Immediate AQM Range Exponent of Ramp Function:

```
Type          Length Value
[24/25].40.5 1      0-25 Exponent to calculate the range of the ramp function(ns)
```

IAQM Range Exponent provides the range of the ramp function (in ns). It is expressed as an exponent of 2. A value of 19 means that the range is  $2^{19} = 524288$  ns (roughly 524  $\mu$ s). With Max Threshold 1000 us, the Minimum Threshold is:  $1000 - 524 = 476$  us.

#### Commands

##### Check AQM configuration

```
Router#show cable modem a84e.3f37.1740 verbose sup | i AQM
  AQM Disable                : 0
  AQM Latency Target         : 12
  AQM Algorithm               : 0
  AQM Max Threshold          : 2000
  AQM Range Exponent         : 19
  AQM Histogram Edge Count   : 15
  AQM Histogram Edges       : 0x00C8  2.00 (ms)  0x0190  4.00 (ms)  0x0258  6.00 (ms)
```

##### Check AQM statistics

```
Router#show cable dp aqm wideband-Cable 1/0/1:4
MAC Address      I/F      Sfid class-name Length/Max  Dequeues qDrops  rDrops pDrops Marked
Target

Latency (ms)
a84e.3f37.18da  Ca1/0/1  17  6--class-map  0/255  0      0      0      0      0
12
a84e.3f37.1740  Ca1/0/1  27  9--class-map  0/255  227968  0      0      0      4124
12
a84e.3f37.102e  Ca1/0/1  33  12--class-map 0/255  0      0      0      0      0
12

pDrops: policer drops
rDrops: random drops
qDrops: tail-drops + random drops
Marked: CE marked
```

## Queue Protection

*Table 189: Feature History*

| Feature Name     | Release Information          | Feature Description                                                                                                                                                                                                                                                                                                                                                                                                                                                                                                                                                                                        |
|------------------|------------------------------|------------------------------------------------------------------------------------------------------------------------------------------------------------------------------------------------------------------------------------------------------------------------------------------------------------------------------------------------------------------------------------------------------------------------------------------------------------------------------------------------------------------------------------------------------------------------------------------------------------|
| Queue protection | Cisco IOS XE Dublin 17.12.1x | <p>In this release, you can configure queue protection for Low Latency Service Flows. Use this feature to identify traffic on low latency flows that does not comply with the non-queue-building behavior and move some of them to classic flows.</p> <p>The benefit of using Queue protection is that latency is reduced for latency-critical applications that are classified to Low Latency Service Flows, that are well-behaved.</p> <p>Reducing the latency can provide more responsive gaming, faster and responsive website loads, and also provide a telepresence experience with minimum lag.</p> |

When certain traffic is erroneously classified to low latency flows, or certain traffic on low latency flows does not behave as non-queue building, then the queue may start to build up. This causes an increase in latency.

The Queue protection feature identifies traffic on low latency flow that does not comply with the non-queue-building behavior, and move some of traffic to classic flows.

### Identifying Misbehaving Microflows

A microflow is identified with 5-tuple values (source/destination address + source/destination ports + protocol) of a packet header. Queue protection identifies the microflows that contribute to queue build up based on **queue scores**. The **queue score** is measured with a token bucket that measures the rate that packets are ECN-marked,. At the time of packet arrival, if the service flow queue score exceeds a certain threshold, then the packet moves to classic flow.

### Moving Packets to Classic Flow

If latency exceeds the configured threshold, and the microflows have been congested for long enough, Queue protection moves the packets to classic flows. It is expected that queue protection may cause packets to be out-of-order. However, this also gives senders an incentive to mark their packets correctly.

### TLV Configuration

#### Queue Protection Enable

```
Type           Length  Value
[70/71].42.7   1       Bit 0 : (0) Queue Protection is disabled
              (1) Queue Protection is enabled (default)
```

#### QPLatencyThreshold (CRITICALqL\_us)

| Type         | Length | Value |
|--------------|--------|-------|
| [70/71].42.8 | 2      | µs    |

#### QPQueueingScoreThreshold (CRITICALqLSCORE\_us)

| Type         | Length | Value |
|--------------|--------|-------|
| [70/71].42.9 | 2      | µs    |

#### QPDrainRateExponent(LG\_AGING)

| Type           | Length | Value                                 |
|----------------|--------|---------------------------------------|
| [70/71].42.10. | 1      | Exponent to calculate the drain rate. |

### Configuring Queue Protection via AQP

You can also configure Queue Protection parameters using AQP. Use the following commands to configure Queue Protection via AQP:

```
cable asf-qos-profile DSASF_AQP ds qp-enable 1
cable asf-qos-profile DSASF_AQP ds qp-latency-threshold 1500
cable asf-qos-profile DSASF_AQP ds qp-score-threshold 32000
cable asf-qos-profile DSASF_AQP ds qp-drain-rate-exp 21
```

You can use the `show cable dp aqm` command to view LLD and Queue protection Statistics.

### MIBs

The `docsQosSfCongestionStatsTable` MIB is supported

|                                                  |           |
|--------------------------------------------------|-----------|
| <code>docsQosSfCongestionSanctionedPkts</code>   | Counter64 |
| <code>docsQosSfCongestionTotalEct0Pkts</code>    | Counter64 |
| <code>docsQosSfCongestionTotalEct1Pkts</code>    | Counter64 |
| <code>docsQosSfCongestionCeMarkedEct1Pkts</code> | Counter64 |

**docsQosSfCongestionSanctionedPkts:** For a Downstream Low Latency Service Flow in the CCAP, this attribute counts the number of packets redirected from the Low Latency Service Flow to the Classic Service Flow. For other Service Flow types in the CCAP, this counter reports 0. For an Upstream Low Latency Service Flow in the CM, this attribute counts the number of packets redirected from the Low Latency Service Flow to the Classic Service Flow. For other Service Flow types in the CM, this counter reports 0.

See [DOCS-QOS3-MIB-2021-06-24.txt](#).

# Aggregate Service Flow

Table 190: Feature History

| Feature Name                                          | Release Information         | Feature Description                                                                                                                                                                                                                                                                                                                    |
|-------------------------------------------------------|-----------------------------|----------------------------------------------------------------------------------------------------------------------------------------------------------------------------------------------------------------------------------------------------------------------------------------------------------------------------------------|
| Updates for Aggregate Service Flow (ASF) Provisioning | Cisco IOS XE Dublin 17.12.1 | You can also use the AQP Expansion procedure to provision ASFs. There are no ASF TLVs present in the REG-REQ. A constituent SF TLV is present and specifies an AQP in the sub-tlv [24/25].4. The cBR-8 router performs an AQP table lookup based on this AQP name and provisions the ASF and constituent SFs from the AQP table entry. |

Aggregate Service Flow (ASF) is a grouping of multiple Service Flows (typically two) which are used to support a hierarchical two-layered subscriber QoS model. The two Service Flows are referred to as the Constituent Service Flows of the ASF. For a Low Latency ASF, one constituent SF is the Low Latency Service Flow, and one is the Classic Service Flow.

ASF can be provisioned statically using three different methods:

- **Method One:** All TLVs for the ASF and constituent SFs are explicitly set in the REG-REQ.
- **Method Two:** The ASF encoding specifies an Aggregate QoS Profile (AQP) using TLV [70/71].4. The ASF is provisioned using a combination of TLVs explicitly set in the REG-REQ and parameters that are configured in the AQP table entry.
- **Method Three:** No ASF TLVs are present in the REG-REQ. A constituent SF TLV is present and specifies an AQP in sub-tlv [24/25].4. The cBR8 router performs an AQP table lookup based on this AQP name and provisions the ASF and constituent SFs from the AQP table entry. This procedure is called *AQP Expansion*.

## ASF QoS Profile (AQP)

SCN is to SF as AQP is to ASF. AQP table entries are configured on the CMTS and referenced by name in the CM config file.

## US/DS Primary SF Determination

- ASF Cannot be Primary.
- LL Constituent SF Cannot be Primary.
- REG-RSP Prim SF Indicator (TLV 90)

## Simple CM Config File

- Type [24/25] SF includes SCN TLV [24/25].4



- Also type [24/25] SF does not include ASF Ref TLV [24/25].36
- The cBR8 router looks up [24/25].4 string in AQP Table first: If found, perform AQP Expansion.
- If not found in AQP Table, CMTS looks up [24/25].4 string as SCN.

### AQP LL SF Classifiers

The default Classifiers for LL Constituent SF when using AQP:

- AQP specified in ASF TLV [70/71].4
- AQP expansion
- EF marked traffic (IPv4): [22/23](7) [9](5) [1](3) 0xB8,0xB8, 0xFC
- EF marked traffic (IPv6) : [22/23](7) [12](5) [1](3) 0xB8,0xB8, 0xFC
- Classifier for all ECT capable traffic(IPv4): [22/23](7) [9](5) [1](3) 0x01, 0x01, 0x01
- Classifier for all ECT capable traffic(IPv6): [22/23](7) [12](5) [1](3) 0x01, 0x01, 0x01
- **Default value for upstream:**  
 0x16 0x07 0x09 0x05 0x01 0x03 0xB8 0xB8 0xFC  
 0x16 0x07 0x0C 0x05 0x01 0x03 0xB8 0xB8 0xFC  
 0x16 0x07 0x09 0x05 0x01 0x03 0x01 0x01 0x01  
 0x16 0x07 0x0C 0x05 0x01 0x03 0x01 0x01 0x01
- **Default value for downstream:**  
 0x17 0x07 0x09 0x05 0x01 0x03 0xB8 0xB8 0xFC  
 0x17 0x07 0x0C 0x05 0x01 0x03 0xB8 0xB8 0xFC  
 0x17 0x07 0x09 0x05 0x01 0x03 0x01 0x01 0x01  
 0x17 0x07 0x0C 0x05 0x01 0x03 0x01 0x01 0x01

### Configuring AQP and View Default Classifiers

The following shows how to configure AQP and view Default Classifiers:

```
Router#configure terminal
Enter configuration commands, one per line . End with CNTL/Z.

Router#configure terminal
Router(config)#cable asf-qos -profile AQPcIassifier01 ds
Router(config)#end
Router#

Router#show cable asf-qos-profile name AQPcIassifier01

Name : AQPcIassifier01
Direction : Downstream
Traffic Priority: 0
Maximum Sustained Rate: 0 bits/ sec
Max Burst: 3044 bytes
Minimum Resemyed Rate: 0 bits/ sec
```

```

Minimum Packet Size                0 bytes
Peak Rate          0 bits/ sec
Low Latency ASF:          true
classic SF scru
Low Latency SF SCN:
AQI•I Coupling Factor:      20
Scheduling Weight:        230
Queue Protection Enable:    true
QP Latency Threshold:      1000
QP Score Threshold:        2000
QP Drain Rate Exponent:    19
Low Latency Classifiers:
                                0x 17070905 0103B8B8 FX17070C 050103B8
                                0x B8FC1707 09050103 01010117 070C0501
                                0x 03010101

```

### Sources of SF Classifiers

- **CM Config File:** Classifiers can point to an SF (SF Ref) or ASF (ASF Ref)
- **AQP:** Classifiers for the Low Latency SF only

cBR-8 router applies Classifiers Pointing to an ASF to a Constituent SF.

- Redirected to the Low Latency Constituent SF:
  - 22/23].9.1 (ToS low/high/mask)
  - [22/23].12.1 (TC low/high/mask)
- All other Classifiers Redirected to the Classic Constituent SF.

**Classifier Conflict:** AQP and CM Cfg File Include Same Classifier for LL SF. cBR-8 router rejects REG-REQ with code reject-invalid-low-latency-config.

### DOCSIS DSX Messaging

ASF can also be provisioned dynamically using DOCSIS DSX messaging. ASF DSX Operations NOT Supported by D31 CM Vendors. cBR-8 Supports DSC Operations on Dynamic SFs Only.

ASF DSA-REQ: MULPI Discrepancy

- DSA-REQ MUST NOT contain multiple SF in one direction.
- ASF DSA-REQ MUST contain ASF + Classic SF + LL SF.



**Note** Starting with Cisco IOS XE Dublin 17.12.1x, aggregate rate shaping for upstream ASF is not supported. US ASF related parameters can be used in the CM configuration file, or in the US AQP, but are not applied by the US scheduler for US ASF.

### Related Topics

[cable asf-qos-profile](#)  
[show cable asf-qos-profile](#)  
[show cable dp aqm](#)  
[show cable modem asf](#)

```
show cable modem asf sup
show cable modem service-flow
show cable modem verbose
show cable modem low-latency-capable
```

# Latency Histogram

Table 191: Feature History

| Feature Name                         | Release Information         | Feature Description                                                                                                                                                                                                              |
|--------------------------------------|-----------------------------|----------------------------------------------------------------------------------------------------------------------------------------------------------------------------------------------------------------------------------|
| Low Latency DOCSIS Histogram Support | Cisco IOS XE Dublin 17.12.1 | Low Latency DOCSIS (LLD) Histograms can now be configured and statistics collected via CLI and new MIBS. This provides visibility into how Active Queue Management (AQM) is managing average latencies on LLD-configured modems. |

Active queue management (AQM) estimates SF queuing latency and uses it for packet marking or dropping. Histogram exposes the estimation data to operators. Estimation is done periodically, all packets within the period are marked with the same latency. Histogram can be collected only on AQM flows, it generates stats on AQM flows. Histogram configuration can be specified using a CM configure file, DSX TLV, service class (CLI or SNMP), or SNMP. Histogram stats can be queried via CLI and SNMP. Histogram Configuration and stats are deleted at SF delete. Histogram stats are cleared at histogram Configuration change. Max SF's number is 64K. A configurable limit b/w 0-64K can be set. Limit default is 4K. Dynamic Flows are not supported.

## Histogram Data Format

Histogram is represented by consecutive bins. Bin's latency range is specified by its lower/upper edges. Nth bin's upper edge is (N+1)th bin's lower edge. First bin's lower edge is 0. Last bin's upper edge is infinite. Edge is u16 with unit in 10us. Up to 15 edges define up to 16 bins. Each bin contains a u64 packet counter for packets whose latency is within the bin's latency range. Latency stats also include A u64 counter for total number of updates and a u16 for maximum latency. The following example shows a sample histogram data format:

Figure 26: Histogram Data Format

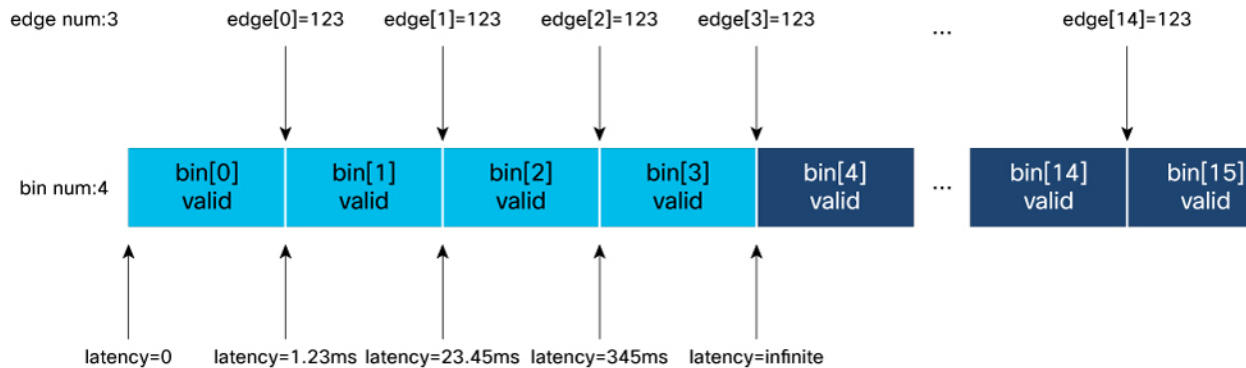

- 4 bins are configured with edge[3]={123, 2345, 34500}.
- Bin[0] counts packets whose latency is 0-1.23ms.
- Bin[1] counts packets whose latency is 1.23ms-23.45ms.
- Bin[2] counts packets whose latency is 23.45ms-345ms.
- Bin[3] counts packets whose latency is 345ms-infinite.
- Bin[4-15] are not used.

### Unsupported Features

- Latency reporting MIB OID defined in DOCS-PNM-MIB: docsCmtsLatencyRptCfgTable
- Histogram Stats Streaming is not supported.

### Configuring Latency Histogram

Histogram edges can be configured in several ways.

- Service class
  - Configuring CLI
  - SNMP
- TLV
  - CM Configure file
  - DSX TLV
- SNMP

### Configuring Info Source Priorities

During CM registration, if CM configures file uses service class, then edges from service class is used as default. If CM configures file contains edges, then they overwrite edges from service class. After CM is online, edges can be updated by DSX TLV or MIB-SET **docsQoSsfLatencyHistCfgEntry**.

### Configuration in SUP IOS

Configuration is stored in 3 places in SUP IOS.

- DOCSIS SF Instance
- DP SF Instance
- DP hist-db

Configuration propagation: docsis sf => dp sf => dp hist-db

The following example shows a sample ShowConfiguration in SUP IOS:

```
Router#show cable modem 0025.2e2d.7648 service-flow verbose
DS Latency Histogram Info (dp-flow)
```

```

Edge Num: 1
Edge Val: 4386 (1122) 0 (0000) 0 (0000) 0 (0000) 0 (0000)
          0 (0000) 0 (0000) 0 (0000) 0 (0000) 0 (0000)
          0 (0000) 0 (0000) 0 (0000) 0 (0000) 0 (0000)
DS Latency Histogram DB [slot:1 md:0 sfid:12]
[CP-KEY] slot:1 md:0 sid:12
[DP-KEY] slot:1 hwid:2609(0xA31)
[ CM ] 0025.2e2d.7648 CML/0/0:1
[ HIST ] edge_num:1 bin_num:0
        update num: 0
        latency max: 0.00 msec
        range in msec | packets
        -----
        [ 0.00 - 43.86) | 0
        [ 43.86 - Inf. ) | 0
DS Latency Histogram Cfg (docsis-flow-sup)
Edge Num: 1
Edge Val: 4386 (1122) 0 (0000) 0 (0000) 0 (0000) 0 (0000)
          0 (0000) 0 (0000) 0 (0000) 0 (0000) 0 (0000)
          0 (0000) 0 (0000) 0 (0000) 0 (0000) 0 (0000)

```

### Configuration via Service Class

New histogram edges field in service class allows all edges for an SF to be specified in one octet string. Each edge corresponds to 2 bytes (4 chars). It must contain even number of bytes. Edge values must be in ascending order.

The following example shows a sample Show Configuration in SUP IOS:

```

Router#configure terminal
Enter configuration commands, one per line. End with CNTL/Z.
tb32(config)#cable service class 123 name foo
tb32(config)#cable service class 123 downstream
tb32(config)#cable service class 123 aqm-histogram-encodings 1122
tb32(config)#end
tb32#
tb32#show cable service-class 123 verbose
Index:      123
Name:       foo
Direction:  Downstream
...
AQM Histogram Num Bin Edges: 1
AQM Histogram Bin Edge Encodings:
      0x1122  43.86(ms)

```

### Configuration via Service Class SNMP

```

$ getmany -v2c 8.32.1.1 public docsQos3ServiceClassEntry | grep -i hist
docsQos3ServiceClassLatencyHistBinEdges.3.102.111.111 = 11 22

$ setany -v2c 8.32.1.1 public docsQos3ServiceClassLatencyHistBinEdges.3.102.111.111 "12 34"
docsQos3ServiceClassLatencyHistBinEdges.3.102.111.111 = 12 34

$ getone -v2c 8.32.1.1 public docsQos3ServiceClassLatencyHistBinEdges.3.102.111.111
docsQos3ServiceClassLatencyHistBinEdges.3.102.111.111 = 12 34

# 3.102.111.111 is service class table entry index.
## 3: indicates index has 3 chars
## 102.111.111: index is "foo"

```

### Octet String Output Format

```
# if output octet string contains non-printable ascii char, like 0x11, 0x12,
# getone will print in byte array format
$ getone -v2c 8.32.1.1 public docsQos3ServiceClassLatencyHistBinEdges.3.102.111.111
docsQos3ServiceClassLatencyHistBinEdges.3.102.111.111 = 12 34 # 0x12 is device ctrl 2

# if all byte values are printable ascii chars, getone will print as ascii string
$ getone -v2c 8.33.1.1 public docsQos3ServiceClassLatencyHistBinEdges.3.102.111.111
docsQos3ServiceClassLatencyHistBinEdges.3.102.111.111 = 3D # 0x33 is "3", 0x44 is "D"

# method to convert it to byte array
$ getone -v2c 8.33.1.1 public docsQos3ServiceClassLatencyHistBinEdges.3.102.111.111 | \
awk -F " = " '{ print $2 }' | tr -d '\n'|od -t x1
000000 33 44
000002
$ getone -v2c 8.33.1.1 public docsQos3ServiceClassLatencyHistBinEdges.3.102.111.111 | \
awk -F " = " '{ print $2 }' | tr -d '\n'|od -An -t x1
33 44
```

### Configuration via CM Configuration File

15 edges: 0xAB01, ..., 0xCF0F

```
Downstream Service Flow Encodings
Service Flow Reference:2
Quality of Service Parameter Set:provisioned admitted active
Traffic Priority:4
Downstream Maximum Sustained Traffic Rate:2000000000
Maximum Traffic Burst:3044
AQM Encodings
SF AQM Disable:Disabled
Classic AQM Latency Target:37
Latency Histogram Encodings:AB01AC02AD03AE04AF05BA
06BC07BD08BE09BF0ACA0BCB0CCD0DCE0ECF0F
```

### Configuration via DSX TLV

Dynamic flows are created by DSA. Dynamic flows are used for voice traffic and use high priority queues. They don't have AQM to collect histogram. Histogram Configuration applied to dynamic flow is ignored. Histogram can be applied to static flows via DSC.

### Configuration via MIB Histogram Configuration Table Entry

```
# change edge while row is active
$ getmany -v2c 8.32.1.1 public docsQos3SfLatencyHistCfgEntry
docsQos3SfLatencyHistCfgStatus.1049.12 = active(1)
docsQos3SfLatencySfLabel.1049.12 =
docsQos3SfLatencyBin1UpperEdge.1049.12 = 4386
docsQos3SfLatencyBin2UpperEdge.1049.12 = 0
...
docsQos3SfLatencyBin15UpperEdge.1049.12 = 0
docsQos3SfLatencyBinEdgeNum.1049.12 = 1

$ setany -v2c 8.32.1.1 public docsQos3SfLatencyBin1UpperEdge.1049.12 4387
docsQos3SfLatencyBin1UpperEdge.1049.12 = 4387

$ getone -v2c 8.32.1.1 public docsQos3SfLatencyBin1UpperEdge.1049.12
docsQos3SfLatencyBin1UpperEdge.1049.12 = 4387
```

```
# sfid can be found in scm <mac> service-flow

# to find snmp ifidx for an MD
$ getmany -v2c 8.33.1.1 public ifDescr | grep "= Cable1/0/0$"
ifDescr.1049 = Cable1/0/0

# show cable dp ds-lat-hist will also show both snmp ifidx and sfid
```

### Events Affecting docsQos3SfLatencyHistCfgEntry

- Events from CLC
  - Flows add may carry histogram configuration from cm configuration file and service class.
  - Flow delete
  - Histogram configuration update from dsx
- Events from SNMP agent
  - Mib-set status: active, destroy, notInService
  - mib-set edges: when row status is active, edges must be in valid ascending order; when row status is notInService, edges don't need to be in ascending order.

### Use Cases for Histogram Configuration Entry

- MIB-GET without MIB-SET can return valid entry that is created by CM registration.
- You can first set status to notInService (provision), change edges (transit edge values can be invalid), and when ready, set status to active.
- During provision, mib-get should return transit Configuration.
- During provision, if CLC sends new Configuration, Mib-get should return Configuration from CLC.
- You can change edges when status is active (as long as edges are valid).
- You can delete the entry by SF delete or set entry status to delete.

### Histogram Limit

The maximum flows that can have histogram that is configured is 64K. To control histogram scale, a configurable "limit" can be set between 0-64K. The default is 4K. When limit is crossed, hist-cfg is rejected, and errmsg is generated.

The following example shows a sample configuration:

```
Router#configure terminal
Router(config)#cable ds-lat-hist limit 1
Router(config)#end
```

### Latency Stats Query

SNMP:

- docsQos3SfLatencyStatsEntry

## CLI:

- Use the **show cable dp ds-lat-hist** command to display latency histogram. The following example displays a sample output.

```
!!! there are total of 64 downstream flows; 2 have histogram configured.
!!! Limit is set to 4K. Supported max capacity is 64K.
!!! ifIndex is snmp_if_index.

Router#show cable dp ds-lat-hist

Total=2 Limit=4096 Capacity=65536 Flows=64

MAC Address      MD-I/F  ifIndex  sfid   hwid  upd-num  max(ms)  range(ms)          packets
0025.2eaf.63a2  C1/0/0  1049    12    2665  123.456K 123.45   0.00 - 43.86 123
                                     43.86 - Inf. 123456
0025.2eaf.63a2  C1/0/0  1049    13    2666  123.456M 655.35   0.00 - 43.86 123
                                     43.86 - 131.24 123456
                                     131.24 - Inf. 1234
```

- Use the **show cable dp aqm inf** command to display aqm info and latency in hist-db. The following example displays a sample output.

```
!!! Histogram stats are set via test command. This is to illustrate the show command
output format. The histogram values do not match target latency.
Router#show cable dp aqm c1/0/0
MAC Address      I/F      Sfid      class-name      Length/Max      Dequeues      qDrops
  rDrops        pDrops      Target      Downstream-Service-Flow-Latency-Stats

                                Latency(ms)  updt_num  Max(ms)  Range  Lo-Hi (ms)  packets
0025.2eaf.63a2  C1/0/0  12        class-default  0/511      0          0
  0              0          15        123.456K 123.45   0.00 - 43.86 123
                                     43.86 - Inf. 123456
0025.2eaf.63a2  C1/0/0  13        2--class-map  0/511      0          0
  0              0          14        123.456M 655.35   0.00 - 43.86 123
                                     43.86 - 131.24 123456
0025.2eaf.638e  C1/0/0  1559      class-default  0/63       0          0
  0              0          15        131.24 - Inf. 1234
0025.2eaf.638e  C1/0/0  1560      2--class-map  0/63       0          0
  0              0          14
```

- Use the **show cable modem mac verbose** command to display histogram info in docsis sf, dp sf, and hist-db. The following example displays a sample output.

```
!!! Show hist info in docsis sf, dp sf, dp hist-db
Router#show cable modem 0025.2e2d.7648 service-flow verbose
...
DS Latency Histogram Info (dp-flow)
Edge Num: 1
Edge Val: 4386 (1122) 0 (0000) 0 (0000) 0 (0000) 0 (0000)
          0 (0000) 0 (0000) 0 (0000) 0 (0000) 0 (0000)
          0 (0000) 0 (0000) 0 (0000) 0 (0000) 0 (0000)
DS Latency Histogram DB [slot:1 md:0 sfid:12]
[CP-KEY] slot:1 md:0 sid:12
[DP-KEY] slot:1 hwid:2609(0xA31)
[ CM ] 0025.2e2d.7648 CM1/0/0:1
[ HIST ] edge_num:1 bin_num:0
         update num: 0
         latency max: 0.00 msec
         range in msec | packets
```



```

-----
[ 0.00 - 43.86) | 0
[ 43.86 - Inf. ) | 0
DS Latency Histogram Cfg (docsis-flow-sup)
Edge Num: 1
Edge Val: 4386 (1122) 0 (0000) 0 (0000) 0 (0000) 0 (0000)
          0 (0000) 0 (0000) 0 (0000) 0 (0000) 0 (0000)
          0 (0000) 0 (0000) 0 (0000) 0 (0000) 0 (0000)

```

- Use the **show interface md service-flow sfid verbose** command to display histogram info in IIOS DP SF instance and hist-db obj. The following example displays a sample output.

```

!!! Same print function as that used by show cm sf cli
Router#show interface c1/0/0 service-flow 12 verbose

Sfid      : 12
Mac Address : 0025.2e2d.7648
...
DS Latency Histogram Info (dp-flow)
Edge Num: 2
Edge Val: 4387 (1123) 4487 (1187) 0 (0000) 0 (0000) 0 (0000)
          0 (0000) 0 (0000) 0 (0000) 0 (0000) 0 (0000)
          0 (0000) 0 (0000) 0 (0000) 0 (0000) 0 (0000)

DS Latency Histogram DB [slot:1 md:0 sfid:12]
[CP-KEY] slot:1 md:0 sid:12
[DP-KEY] slot:1 hwid:2609(0xA31)
[ CM ] 0025.2e2d.7648 CM1/0/0:1
[ HIST ] edge_num:2 bin_num:3
         update num: 7890000000
         latency max: 45.67 msec
         range in msec | packets
-----
[ 0.00 - 43.87) | 567898765
[ 43.87 - 44.87) | 123
[ 44.87 - Inf. ) | 456

```

### SF Latency Stats MIB-GET

```

$ getmany -v2c 8.32.1.1 public docsQos3SfLatencyStatsEntry
docsQos3SfLatencyMaxLatency.1049.12 = 4567
docsQos3SfLatencyNumHistUpdates.1049.12 = 7890000000
docsQos3SfLatencyBin1Pkts.1049.12 = 567898765
docsQos3SfLatencyBin2Pkts.1049.12 = 123
docsQos3SfLatencyBin3Pkts.1049.12 = 456
docsQos3SfLatencyBin4Pkts.1049.12 = 0
docsQos3SfLatencyBin5Pkts.1049.12 = 0
docsQos3SfLatencyBin6Pkts.1049.12 = 0
docsQos3SfLatencyBin7Pkts.1049.12 = 0
docsQos3SfLatencyBin8Pkts.1049.12 = 0
docsQos3SfLatencyBin9Pkts.1049.12 = 0
docsQos3SfLatencyBin10Pkts.1049.12 = 0
docsQos3SfLatencyBin11Pkts.1049.12 = 0
docsQos3SfLatencyBin12Pkts.1049.12 = 0
docsQos3SfLatencyBin13Pkts.1049.12 = 0
docsQos3SfLatencyBin14Pkts.1049.12 = 0
docsQos3SfLatencyBin15Pkts.1049.12 = 0
docsQos3SfLatencyBin16Pkts.1049.12 = 0

```

**OIDs from DOCS-QOS3-MIB**

docsQos3ServiceClassEntry 1.3.6.1.4.1.4491.2.1.21.1.8.1

docsQos3SflLatencyHistCfgEntry 1.3.6.1.4.1.4491.2.1.21.1.29.1.1

docsQos3SflLatencyStatsEntry 1.3.6.1.4.1.4491.2.1.21.1.29.2.1

**Error Message**

- CBR\_DP\_HIST\_LIMIT\_ERR
  - It is generated when you try to apply histogram Configuration to more SFs than the configured limit.
  - It won't affect CM online.
  - Increase limit via Configuration command.
- CBR\_DP\_HIST\_SEARCH\_ERR
  - Generated when try to apply histogram Configuration to an SF not found in hist-db.
  - If hist-cfg is entered via mib-set, check ifidx and sfid values.

**Clear Command**

Use the **clear cable ds-lat-hist {cfg-stat|stat-only} [md-if|cm-mac] [sfid]** command to clear histogram stats.

**Table 192: Clear Command**

| Clear Command                                       | Description                                               |
|-----------------------------------------------------|-----------------------------------------------------------|
| clear cable<br>ds-lat-hist stat-only                | Clear histogram stats of all the ds flows                 |
| clear cable<br>ds-lat-hist stat-only 1111.2222.3333 | Clear all histogram stats on given CM                     |
| clear cable<br>ds-lat-hist cfg-stat C1/0/0 12       | Clear histogram Configuration and stat from given md/sfid |
| clear cable<br>ds-lat-hist cfg-stat                 | Clear everything.                                         |

**FMAN Show Commands**

```
!!! show fman rp
show platform software object-manager r0 object-type-info | i HIST
show platform software object-manager r0 object-type-count | i HIST
!!! show fman fp
show platform software object-manager f0 object-type-count | i HIST
!!! show fman-rp/fp db
show platform software cable r0 hist
show platform software cable f0 hist
!!! show fman-fp aom
show platform software cable f0 hist aom-stati
```

**CPP-CP QoS Show Commands**

```
Router#show platform hardware qfp active feature qos config output interface CM1/0/0:1
ds-hist-ids
Interface: CM1/0/0:1, QFP if_h: 7019, Num Targets: 1
  Target: Out, Num UIDBs: 1
    UIDB #: 0
    Hierarchy level: 0, Num matching iftgts: 1
    Policy name: 1--policy-map, Policy id: 1699264
    Parent Class Idx: 0, Parent Class ID: 0
    IF Tgt#: 0, ifh: 7019, member_ifh: 0, link_idx: 0
DS Hist IDs Table:
```

| Index | CID  | Class Name    | Slot_Hwid  | Hash       |
|-------|------|---------------|------------|------------|
| 0     | 1593 | class-default | 0x01000a31 | 0x000001c9 |

Router#

**CPP-CP JIB Show Commands**

```
Router#show platform hardware qfp active cable hist slot 1 hwid 2609
slot: 1
hwid: 2609
cp_edge_num: 2
cp_edge_val: 4387 4487 0 0 0 <<< from cpp-cp-jib hist-db
              0 0 0 0 0
              0 0 0 0 0

dp_ent_idx: 457, hex: 0x1c9
dp_ent_rsrc_h: 0x0111af0009080003
dp_ent_ppe_addr: 0x00000000591af000
dp_ent_slot_hwid: 0x01000a31
dp_ent_edge_num: 2
dp_ent_edge_val: 4387 4487 0 0 0 <<< from cpp exmem
                  0 0 0 0 0
                  0 0 0 0 0

dp_sbs_idx: 1
dp_sbs_rsrc_h: 0x0111ad0a00000003
dp_sbs_ppe_addr: 0x00000000591ad0a0
dp_sbs_upd_num: 0
dp_sbs_lat_max: 0
dp_sbs_bin_val: 0 0 0 0 0 <<< from cpp exmem
                 0 0 0 0 0
                 0 0 0 0 0
                 0 0 0 0 0
```

# Enabling Packet Classification for DOCSIS Compliance

Table 193: Feature History

| Feature                                                            | Release Information         | Feature Description                                                                                                                                                                                                          |
|--------------------------------------------------------------------|-----------------------------|------------------------------------------------------------------------------------------------------------------------------------------------------------------------------------------------------------------------------|
| Ability to enable packet classifier in compliant with DOCSIS spec. | Cisco IOS XE Dublin 17.12.1 | You can now enable the packet classifier that is provisioned already to be compliant with the DOCSIS spec. This helps to match the IPv4 type of service (ToS) or IPv6 Traffic Class (TC) value range as per the DOCSIS spec. |

Starting with Cisco IOS XE Dublin 17.12.1, you can enable the packet classifier that is provisioned already to be compliant with the DOCSIS spec. This helps in achieving low-latency and ensures that the cBR-8 is in compliant with the DOCSIS spec to match the ECN bits. Explicit Congestion Notification (ECN) is a TCP or IP extension that can avoid packet loss and thus improve network performance.

The packet now matches the classifier only when the following condition is satisfied as per DOCSIS spec:

- $(\text{low AND mask}) \leq (\text{ToS/TC value AND mask}) \leq (\text{high AND mask})$

Low and Mask values are lesser than or equal to the ToS or TC bits in the packet header and Mask that must be lesser than or equal to the High and Mask values.

Prior to Cisco IOS XE Dublin 17.12.1, the cBR-8 was not compliant with the DOCSIS specs.

In earlier releases, the packet matches the classifier based on the following classification condition:

- $(\text{low AND mask}) = (\text{ToS/TC value AND mask})$

Low and Mask values are equal to the ToS or TC bits in packet header and Mask values.



---

**Note** Prior to 17.12.1, the lowest two bits are excluded.

---



## PART VI

# Layer 2 and Layer 3 VPN Configuration

- [L2VPN Support over Cable, on page 875](#)
- [L2VPN Over Port-Channel, on page 893](#)
- [MPLS Pseudowire for Cable L2VPN, on page 897](#)
- [MPLS VPN Cable Enhancements, on page 929](#)
- [Multicast VPN and DOCSIS 3.0 Multicast QoS Support, on page 947](#)
- [EtherChannel for the Cisco CMTS, on page 959](#)
- [Flow-Based per Port-Channel Load Balancing, on page 969](#)
- [MPLS QoS via TLV for non-L2VPN Service Flow, on page 979](#)
- [IPsec Security Support, on page 987](#)





## CHAPTER 51

# L2VPN Support over Cable

The Layer 2 VPN (L2VPN) Support over Cable feature on the Cisco CMTS provides point-to-point Transparent LAN Service (TLS) in support of the Business Services over DOCSIS (BSOD) Cable Labs specification.

The L2VPN Support over Cable feature supports the following:

- The feature uses an Ethernet trunking interface to transport traffic for multiple L2VPNTunnels in support of different cable modems (CMs) and service flows (SFs) based on IEEE 802.1q VLAN IDs. For the legacy TLS service, only the primary upstream or downstream SFs are used. With the new L2VPNSupport over Cable feature, both primary and secondary SFs can be used.
- The TLS feature uses CLI to provision the service. The L2VPN Support over Cable feature uses the CM configuration file to provision the service, and a single CLI to identify the default Ethernet Network System Interface (NSI).
- Downstream traffic is forwarded on a per-CM basis and upstream traffic is forwarded on a per-SF basis. For L2VPN Support over Cable feature, upstream traffic for the same L2VPN can use multiple upstream service flows and downstream traffic can use different downstream service flows.
- [Finding Feature Information, on page 875](#)
- [Hardware Compatibility Matrix for the Cisco cBR Series Routers, on page 876](#)
- [Prerequisites for L2VPN Support over Cable, on page 877](#)
- [Restrictions for L2VPN Support over Cable, on page 877](#)
- [Information About L2VPN Support over Cable, on page 878](#)
- [Voice-Call Support on L2VPN CM, on page 882](#)
- [How to Configure L2VPN Support over Cable, on page 882](#)
- [Configuration Examples for L2VPN over Cable, on page 887](#)
- [Additional References, on page 890](#)
- [Feature Information for L2VPN Support over Cable, on page 891](#)

## Finding Feature Information

Your software release may not support all the features that are documented in this module. For the latest feature information and caveats, see the release notes for your platform and software release. The Feature Information Table at the end of this document provides information about the documented features and lists the releases in which each feature is supported.

Use Cisco Feature Navigator to find information about platform support and Cisco software image support. To access Cisco Feature Navigator, go to <http://tools.cisco.com/ITDIT/CFN/>. An account on <http://www.cisco.com/> is not required.

## Hardware Compatibility Matrix for the Cisco cBR Series Routers



**Note** The hardware components that are introduced in a given Cisco IOS-XE Release are supported in all subsequent releases unless otherwise specified.

**Table 194: Hardware Compatibility Matrix for the Cisco cBR Series Routers**

| Cisco CMTS Platform                    | Processor Engine                                                                                                                                                                                  | Interface Cards                                                                                                                                                                                                                                                                                                                                                                                                                                                                                                                                                                                                                                                                                                                                                                                 |
|----------------------------------------|---------------------------------------------------------------------------------------------------------------------------------------------------------------------------------------------------|-------------------------------------------------------------------------------------------------------------------------------------------------------------------------------------------------------------------------------------------------------------------------------------------------------------------------------------------------------------------------------------------------------------------------------------------------------------------------------------------------------------------------------------------------------------------------------------------------------------------------------------------------------------------------------------------------------------------------------------------------------------------------------------------------|
| Cisco cBR-8 Converged Broadband Router | <p><b>Cisco IOS-XE Release 16.5.1 and Later Releases</b></p> <p>Cisco cBR-8 Supervisor:</p> <ul style="list-style-type: none"> <li>• PID—CBR-SUP-250G</li> <li>• PID—CBR-CCAP-SUP-160G</li> </ul> | <p><b>Cisco IOS-XE Release 16.5.1 and Later Releases</b></p> <p>Cisco cBR-8 CCAP Line Cards:</p> <ul style="list-style-type: none"> <li>• PID—CBR-LC-8D30-16U30</li> <li>• PID—CBR-LC-8D31-16U30</li> <li>• PID—CBR-RF-PIC</li> <li>• PID—CBR-RF-PROT-PIC</li> <li>• PID—CBR-CCAP-LC-40G</li> <li>• PID—CBR-CCAP-LC-40G-R</li> <li>• PID—CBR-CCAP-LC-G2-R</li> <li>• PID—CBR-SUP-8X10G-PIC</li> <li>• PID—CBR-2X100G-PIC</li> </ul> <p>Digital PICs:</p> <ul style="list-style-type: none"> <li>• PID—CBR-DPIC-8X10G</li> <li>• PID—CBR-DPIC-2X100G</li> </ul> <p>Cisco cBR-8 Downstream PHY Module:</p> <ul style="list-style-type: none"> <li>• PID—CBR-D31-DS-MOD</li> </ul> <p>Cisco cBR-8 Upstream PHY Modules:</p> <ul style="list-style-type: none"> <li>• PID—CBR-D31-US-MOD</li> </ul> |





**Note** Do not use DPICs (8X10G and 2x100G) to forward IP traffic, as it may cause buffer exhaustion, leading to line card reload.

The only allowed traffic on a DPIC interface is DEPI, UEPI, and GCP traffic from the Cisco cBR-8 router to Remote PHY devices. Other traffic such as DHCP, SSH, and UTSC should flow via another router, since DPICs cannot be used for normal routing.

## Prerequisites for L2VPN Support over Cable

- You should use crypto-supported images.
- Cable modems must be configured to support BPI+.

## Restrictions for L2VPN Support over Cable

The L2VPN Support over Cable feature has the following general restrictions:

- DOCSIS 1.0 CMs are not supported.
- Load balancing and Dynamic Channel Change (DCC) are not supported for CMs that are enabled for L2VPN support.
- DSx messages (Dynamic Service Add [DSA], Dynamic Service Change [DSC], and Dynamic Service Delete [DSD]) are supported for L2VPN-provisioned CMs. However, DSx with L2VPN type, length, values (TLVs) are not supported.
- Multipoint L2VPN is not supported, and any Simple Network Management Protocol (SNMP) MIBs for multipoint L2VPN are not supported.
- eSAFE (embedded Service/Application Functional Entities) DHCP snooping is not supported (L2VPN subtype 43.5.3)
- Maximum of 1024 L2VPNs are supported on a single MAC domain.
- Maximum of eight upstream SFs are supported per L2VPN service.
- Maximum of eight downstream classifiers are supported per L2VPN service.
- eSAFE exclusion is supported for only one eSAFE host. If the REG-REQ message for a compliant CM specifies multiple eSAFE hosts, then the eMTA (ifIndex 16) is selected as the eSAFE host to be excluded by the Cisco CMTS router. If the eMTA is not included as part of the capability of the CM, then the first eSAFE host in the capability is selected for exclusion.
- Maximum length of the Cable Modem Interface Mask (CMIM) is 4 bytes.
- Areas of the Business Services over DOCSIS (BSOD) Layer 2 Virtual Private Networks specification that are not supported are:
  - Vendor-specific L2VPN encodings for the replacement of the required VPN ID and NSI Encapsulation subtype are not supported.
  - Mapping of egress user priority to an NSI port transmission traffic class as specified by IEEE 802.1s is not supported.
  - Forwarding with non-zero default user priority values with vendor-specific configuration is not supported.

- Accepting multiple Downstream Classifier L2VPN Encoding with the same VPN ID to classify packets to different service flows is not supported.
- Assigning multiple SAIDs to the same L2VPN on the same CM is not supported. The primary SAID is used for encrypting all downstream traffic.
- Assigning of the same group-level L2VPN SAID to different CMs on the same MAC domain attached to the same L2VPN identifier is not supported.
- Implementing the DOCSIS Spanning Tree Protocol (DSTP) and transmission of DSTP BPDUs on all NSI and RF interfaces configured for L2VPN operation is not supported.
- Implementing a DSTP SAID specifically for DSTP forwarding to the customer premises equipment (CPE) ports of all L2VPN CMs is not supported.
- dot1q L2VPN is not supported over a port-channel with load-balancing vlan configured.

## VPN ID Restrictions

- A maximum of four VPN IDs are supported for each CM.
- A maximum of one VPN ID can be associated with each SF in a CM; although multiple SFs in a CM can belong to the same L2VPN.
- A maximum of 4093 unique VPN IDs are supported per Cisco CMTS router.
- The maximum length of a VPN ID is 16 bytes.
- All L2VPN encodings must contain a VPN ID, except for upstream classifier encodings.

## Information About L2VPN Support over Cable

L2VPN Support Over Cable provides the following benefits and functions on a Cisco CMTS router:

- Supports point-to-point L2VPN forwarding mode.
- Supports up to four VPN IDs per CM.
- Supports multiple upstream SFs per CM, with one or more SFs belonging to the same VPN ID.
- Supports a single Ethernet NSI that serves as a trunking port for one or more L2VPN tunnels on the Cisco CMTS router.
- Supports BPI+ encryption using primary SAID of the CM.
- Supports L2VPN encodings in the CM configuration file and CM registration (REG-REQ with L2VPN encoding).
- Supports upstream L2VPN tunnel in support of per-CM and per-SF forwarding.
- Supports synchronization and recovery of the L2VPN database and upstream and downstream SFs during SUP NSF/SSO and N+1 line card redundancy switchovers.
- Supports QoS in upstream and downstream.
- Supports stacked IEEE 802.1q tags.
- Supports exclusion of traffic from the L2VPN tunnel for a single Embedded Service/Application Functional Entity (eSAFE) host.
- Supports Layer 2 classifier via CMIM and IEEE 802.1p priority bits.
- Supports detection of provisioning errors, such as duplicate VLAN IDs across CMs or existing VLAN IDs in use, and moves a CM offline with a corresponding error message.
- Supports coexistence of L2VPN and non-L2VPN traffic on the same RF MAC domain, with non-L2VPN traffic isolated from other tunnel traffic.
- Supports voice calls from L2VPN-provisioned CMs. However, voice calls are not part of the L2VPN.

- Supports BSOD VLAN Redundancy feature, which allows users to configure a backup WAN interface in addition to the primary WAN interface. When the primary WAN interface is down, the L2VPN traffic flows through the backup WAN interface.
- Supports manual switchover for VLAN Redundancy feature, which allows users to manually switch active uplink port from the current port to another port when both the uplink ports are up.
- Supports 2000 bytes layer 2 MTU.

## Point-to-Point L2VPN Forwarding Mode

The Cisco CMTS routers supports the point-to-point L2VPN forwarding mode described in the BSOD specification. Each attachment circuit (either SF or CM) on the Cisco CMTS router has a NSI encapsulation value, and is configured with an IEEE 802.1q VLAN ID.

The L2VPN forwarder on the Cisco CMTS router forwards both upstream and downstream traffic between the NSI port on the router and an attachment circuit without using MAC address learning for the forwarding decision. A L2VPN bridge on the backbone network of the cable operator performs the MAC-address learning to bridge packets between VLAN IDs.

The image below shows an example of a point-to-point L2VPN network using IEEE 802.1q NSI encapsulation. In this example, four CMs are associated with four different VLAN IDs: 10, 20, 30, and 40. The L2VPN encoding of the CM includes the logical L2VPN ID (in this case, A or B) with an NSI encapsulation subtype for IEEE 802.1q with the associated VLAN ID.

Figure 27: Point-to-Point L2VPN Network Diagram

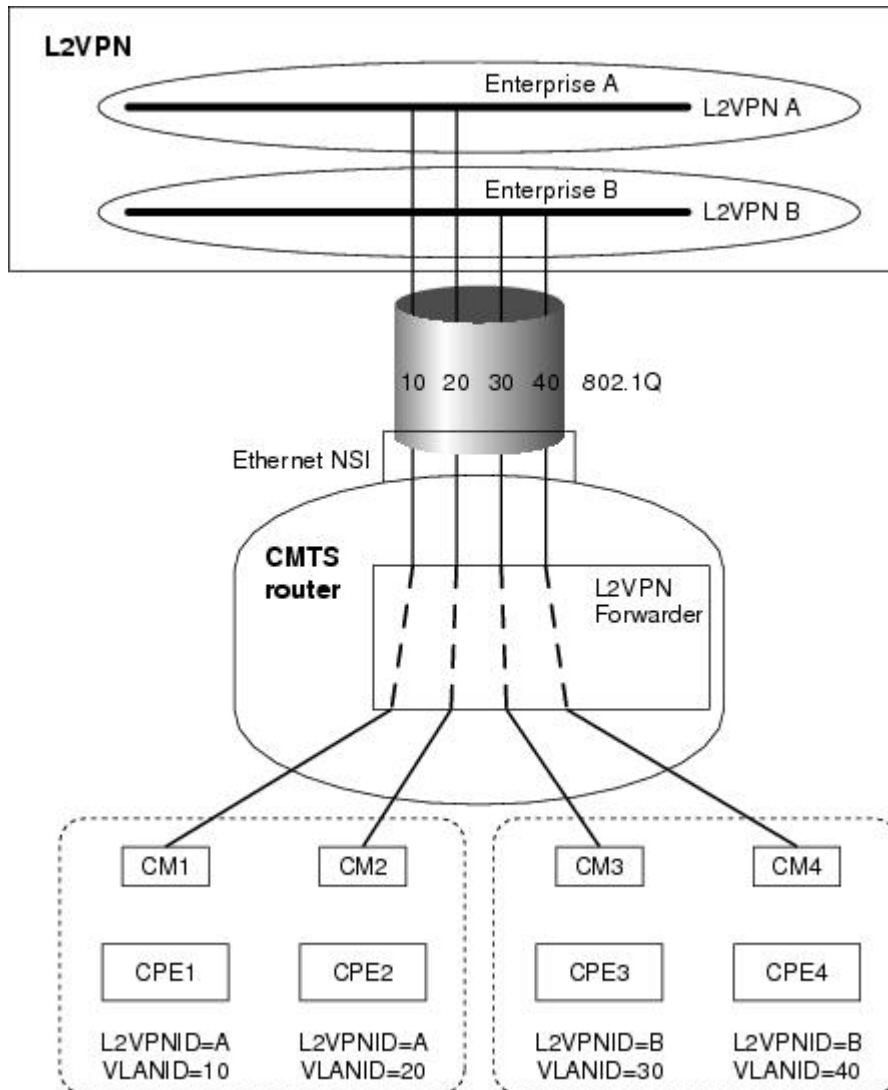

The logical L2VPN IDs allow creation of separate broadcast domains for certain VLAN IDs. In the diagram, traffic for VLANs 10 and 20 from CM1 and CM2 can be sent to the network of Enterprise A, and traffic for VLAN's 30 and 40 from CM3 and CM4 can be sent to the network of Enterprise B.

## L2VPN Encodings in the CM Configuration File

The CM configuration file contains a set of L2VPN encodings that control how the Cisco CMTS processes L2VPN forwarding of upstream and downstream CPE packets. As per the BSOD specification, the L2VPN encoding is encapsulated using a General Extension Information (GEI) encoding, which uses the type code 43 and subtype of 5 (43.5) with the reserved Vendor ID of 0xFFFFF.

L2VPN defines the following types of encodings:

- Per-CM L2VPN encodings—An encoding that appears at the top level of the CM configuration file.

- Per-SF L2VPN Encoding—An encoding that appears as a subtype of the Upstream Service Flow Encoding (type 24).
- Upstream Classifier L2VPN Encoding—An encoding that appears in an Upstream Packet Classification Configuration Setting (type 22).
- Downstream Classifier L2VPN Encoding—An encoding that appears in a Downstream Packet Classification Configuration Setting (type 23).

The simplest CM configuration file has a single per-SF L2VPN Encoding within the primary upstream SF definition and a single per-CM L2VPN Encoding with a NSI Encapsulation subtype for that L2VPN.



**Note** When BSOD (CM configuration file) is used for L2VPN configuration, and QoS policy-map settings are applied to Cisco CMTS WAN interfaces, the packets do not match the QoS policy-map. When CLI mode is used for L2VPN configuration, and QoS policy-map settings are applied to Cisco CMTS WAN interfaces, the packets will match the QoS policy-map first.



**Note** Cisco CMTS supports BSOD VLAN redundancy feature with support for two Ethernet Network Side Interface (NSI) configuration and a backup WAN interface. When the active NSI WAN interface is down, the L2VPN traffic flows through the backup WAN interface.

## Supported L2VPN Encodings

This section describes the supported L2VPN encodings in the CM configuration file that are supported by the Cisco CMTS routers.

- The Cisco CMTS routers support the following CM capabilities:
  - L2VPN capability (5.17)
  - eSAFE host capability (5.18)
  - Downstream Unencrypted Traffic (DUT) filtering (5.19)
- The Cisco CMTS routers support the following top-level encodings:
  - VPN identifier (43.5.1)
  - CMIM (43.5.4)—When provided, applies to all upstream SFs associated with an L2VPN tunnel; Supports only one eSAFE host.
  - NSI encapsulation (43.5.2) with format code 2 for IEEE 802.1q (43.5.2.2)
  - DUT filtering encoding
- The Cisco CMTS routers support the following per-SF encodings:
  - VPN identifier (43.5.1)
  - Ingress user priority (43.5.8)

- The Cisco CMTS routers support the following downstream classifier encodings:
  - VPN identifier (43.5.1)
  - CMIM (43.5.4) and (22/23.13)
  - User priority range (43.5.9)

For more information about the CM configuration file and L2VPN encodings, see the "Business Services over DOCSIS (BSOD) Layer 2 Virtual Private Networks" specification.

For information about how to use the configuration file generator on the Cisco CMTS, see the "DOCSIS Internal Configuration File Generator for the Cisco CMTS" document.

## Voice-Call Support on L2VPN CM

Voice calls are supported on L2VPN CMs. This feature enables the Cisco CMTS routers to support dynamic service flows on L2VPN-provisioned cable modems to permit voice calls from a non-L2VPN CPE.

To provide voice-call support on a L2VPN CM, you have to configure correct classifiers and create two static service flows (primary and secondary) using the cable modem configuration file. If the eMTA is L2VPN-capable with the embedded CPE configured as an eSAFE host, then only one service flow is required. When correct CMIM bits are configured, the Cisco CMTS does not send packets from the eSAFE host to the L2VPN.

Though the L2VPN can be configured on the primary or secondary service flow, it cannot coexist with eMTAs on the same service flow. The eMTAs should always use a different service flow from that of L2VPN. The classifiers to direct the traffic should also be based on the service flows the L2VPN and eMTAs are using. When the above configuration is in place, the dynamic service flows are created automatically whenever voice calls are initiated.

## How to Configure L2VPN Support over Cable

This section contains the following procedures:

### Configuring the Ethernet Network System Interface

To configure the L2VPN Support over Cable feature, you need to specify an Ethernet NSI to operate as the trunking interface for the L2VPN traffic. You must configure the NSI using a command on the Cisco CMTS router. It is not configurable through the CM configuration file.

#### Before you begin

The following interface types can be configured as an NSI for L2VPN Support over Cable:

- Cisco cBR Series Converged Broadband Router—GigabitEthernet and TenGigabitEthernet



**Note** The Cisco CMTS routers only support the configuration of a single L2VPN NSI per CMTS.

>

## Procedure

|        | Command or Action                                                                                                                                                                                                                | Purpose                                                                                                                                                              |
|--------|----------------------------------------------------------------------------------------------------------------------------------------------------------------------------------------------------------------------------------|----------------------------------------------------------------------------------------------------------------------------------------------------------------------|
| Step 1 | <b>enable</b><br><b>Example:</b><br>Router> enable                                                                                                                                                                               | Enables privileged EXEC mode. <ul style="list-style-type: none"> <li>• Enter your password if prompted.</li> </ul>                                                   |
| Step 2 | <b>configure terminal</b><br><b>Example:</b><br>Router# configure terminal                                                                                                                                                       | Enters global configuration mode.                                                                                                                                    |
| Step 3 | <b>cable l2-vpn-service xconnect nsi dot1q interface ethernet-intf [backup-interface ethernet-intf]</b><br><b>Example:</b><br>Router(config)# cable l2-vpn-service xconnect nsi dot1q interface Te4/1/0 backup-interface Te4/1/4 | Configures WAN interface for DOT1Q L2VPN .<br>(Optional) Backup-interface - If backup-interface is configured it means that BSoD VLAN redundancy feature is enabled. |

## Preparing the DOCSIS Configuration File for L2VPN Support

To support L2VPN, the DOCSIS configuration file must be configured with the appropriate encodings. For information about the supported encodings by the Cisco CMTS routers, see the [L2VPN Encodings in the CM Configuration File, on page 880](#).

## Manual Switchover Command Line Interface

For BSoD VLAN Redundancy feature, users can manually switch active uplink ports from the active port to another port when both the uplink ports are up through the command line interface. To manually switchover, perform the following steps:

### SUMMARY STEPS

1. **enable**
2. **cable l2-vpn dot1q-nsi-redundancy force-switchover from *active-nsi-interface***

### DETAILED STEPS

|        | Command or Action                                  | Purpose                                                                                                           |
|--------|----------------------------------------------------|-------------------------------------------------------------------------------------------------------------------|
| Step 1 | <b>enable</b><br><b>Example:</b><br>Router> enable | Enables privileged EXEC mode. <ul style="list-style-type: none"> <li>• Enter your password if prompted</li> </ul> |

|               | Command or Action                                                                                                                                                                            | Purpose                                                                             |
|---------------|----------------------------------------------------------------------------------------------------------------------------------------------------------------------------------------------|-------------------------------------------------------------------------------------|
| <b>Step 2</b> | <b>cable l2-vpn dot1q-nsi-redundancy force-switchover from <i>active-nsi-interface</i></b><br><br><b>Example:</b><br>Router# cable l2-vpn dot1q-nsi-redundancy force-switchover from Te4/0/1 | Switches the active uplink port from the current active port to the specified port. |

To display the dot1q L2VPN uplink redundancy information, use the **show cable l2-vpn dot1q-nsi-redundancy** as shown in the following example:

```
Router# show cable l2-vpn dot1q-nsi-redundancy
Primary-NSI Backup-NSI Active-NSI Elapsed-after-SW
Te4/1/0      Te4/0/4      Te4/1/0      31m9s
Te4/1/2      Te4/0/5      Te4/1/2      59s
```

## Verifying L2VPN Support over Cable

To verify L2VPN information on the Cisco CMTS router, use the **show cable l2-vpn xconnect dot1q-vc-map** command.

### SUMMARY STEPS

1. To display VLAN information for all cable modems, use the **show cable l2-vpn xconnect dot1q-vc-map** command as shown in the following example:
2. To display VLAN information for a particular L2VPN ID or customer, use the **show cable l2-vpn xconnect dot1q-vc-map customer** form of the command as shown in the following example:
3. To display information for a particular L2VPN ID on a specific cable modem, use the **show cable l2-vpn xconnect dot1q-vc-map vpn** form of the command along with specification of the cable modem MAC address, as shown in the following example:
4. To display detailed information for a particular L2VPN ID on a specific cable modem, use the **show cable l2-vpn xconnect dot1q-vc-map vpn verbose** form of the command along with specification of the cable modem MAC address, as shown in the following example:
5. To display detailed information and the current redundancy information for a particular cable modem, use the **show cable l2-vpn xconnect dot1q-vc-map verbose** form of the command along with specification of the cable modem MAC address, as shown in the following example:
6. To display the dot1q L2VPN uplink redundancy information, use the **show cable l2-vpn dot1q-nsi-redundancy** as shown in the following example:

### DETAILED STEPS

**Step 1** To display VLAN information for all cable modems, use the **show cable l2-vpn xconnect dot1q-vc-map** command as shown in the following example:

**Example:**

```
Router# show cable l2-vpn xconnect dot1q-vc-map
MAC Address      Ethernet Interface      VLAN ID      Cable Intf  SID      Customer Name/VPN ID
0014.f8c1.fd66  GigabitEthernet4/0/0    68           Cable6/0/0  3        0234560001
```



- Step 2** To display VLAN information for a particular L2VPN ID or customer, use the **show cable l2-vpn xconnect dot1q-vc-map customer** form of the command as shown in the following example:

**Example:**

```
Router# show cable l2-vpn xconnect dot1q-vc-map customer 0234560001

MAC Address      Ethernet Interface      VLAN ID   Cable Intf  SID   Customer Name/VPNID
0014.f8c1.fd66  GigabitEthernet4/0/0    68       Cable6/0/0  3     0234560001
```

- Step 3** To display information for a particular L2VPN ID on a specific cable modem, use the **show cable l2-vpn xconnect dot1q-vc-map vpn** form of the command along with specification of the cable modem MAC address, as shown in the following example:

**Example:**

```
Router# show cable l2-vpn xconnect dot1q-vc-map 0014.f8c1.fd66 vpn 0234560001

MAC Address      Ethernet Interface      VLAN ID   Cable Intf  SID   Customer Name/VPNID
0014.f8c1.fd66  GigabitEthernet4/0/0    68       Cable6/0/0  3     0234560001
```

- Step 4** To display detailed information for a particular L2VPN ID on a specific cable modem, use the **show cable l2-vpn xconnect dot1q-vc-map vpn verbose** form of the command along with specification of the cable modem MAC address, as shown in the following example:

**Example:**

```
Router# show cable l2-vpn xconnect dot1q-vc-map 0014.f8c1.fd66 vpn 0234560001 verbose
MAC Address                : 0014.f8c1.fd66
Prim Sid                    : 3
Cable Interface            : Cable6/0/0
VPN ID                     : 0234560001
L2VPN SAID                 : 12294
Upstream SFID              : 23
Downstream CFRID[SFID]    : 2[24]
CMIM                       : 0x60
Ethernet Interface         : GigabitEthernet4/0/0
DOT1Q VLAN ID              : 68
Total US pkts              : 1372
Total US bytes             : 500226
Total US pkt Discards      : 0
Total US byte Discards     : 0
Total DS pkts              : 1248
Total DS bytes             : 415584
Total DS pkt Discards      : 0
Total DS byte Discards     : 0
```

- Step 5** To display detailed information and the current redundancy information for a particular cable modem, use the **show cable l2-vpn xconnect dot1q-vc-map verbose** form of the command along with specification of the cable modem MAC address, as shown in the following example:

**Example:**

```
Router# show cable l2-vpn xconnect dot1q-vc-map 0014.f8c1.fd66 verbose
MAC Address                : 5039.5589.4302
Prim Sid                   : 45
Cable Interface            : Cable6/0/2
L2VPNs provisioned        : 1
DUT Control/CMIM          : Disable/0x8000FFFF
```

```

VPN ID : 000234560001
L2VPN SAID : 45
Upstream SFID Summary : 77
Upstream SFID [77 ] : SID 45
Downstream CFRID[SFID] Summary : Primary SF
CMIM : 0x60
Primary Ethernet Interface : GigabitEthernet4/0/0
Backup Ethernet Interface : GigabitEthernet4/0/1
Active Ethernet Interface : GigabitEthernet4/0/0
DOT1Q VLAN ID : 207
Total US pkts : 151269
Total US bytes : 211755224
Total DS pkts : 150502
Total DS bytes : 210463324

```

**Step 6** To display the dot1q L2VPN uplink redundancy information, use the **show cable l2-vpn dot1q-nsi-redundancy** as shown in the following example:

**Example:**

```

Router# show cable l2-vpn dot1q-nsi-redundancy
Primary-NSI Backup-NSI Active-NSI Elapsed-after-SW
Te4/1/0      Te4/0/4      Te4/1/0      31m9s
Te4/1/2      Te4/0/5      Te4/1/2      59s

```

## Enabling Voice-Call on a L2VPN CM

You can enable the Voice-Call Support on a L2VPN CM feature by registering a cable modem with a SID to VPN mapping cable modem configuration file (MPLS or 802.1q).

- If the L2VPN is on the primary service flow, you should use a cable modem configuration file with static secondary service flow and the classifiers should be configured on the secondary service flow for non-L2VPN packets.
- If the L2VPN is on the secondary service flow, then classifiers should be configured for L2VPN packets.



**Note** The cable modem configuration file based L2VPN configuration provides the flexibility to configure L2VPN on the primary or secondary service flow. However, we recommend that you configure L2VPN on the secondary service flow and the primary service flow is used for the default traffic.



**Note** In a CLI-based L2VPN configuration, the L2VPN is on the primary service flow; therefore the static secondary service flow should be used for the eMTAs.

## Verifying Dynamic Service Flows

To verify dynamically created service flows on the Cisco CMTS router, use the **show interface cable service-flow** command.



**Note** To verify information about PacketCable operations, use **show packetcable** commands.

```
Router# show interface cable 5/1/0 service-flow
Sfid : 30191
Mac Address : 000a.739e.140a
Type : Secondary(Dynamic)
Direction : Upstream
Current State : Active
Current QoS Indexes [Prov, Adm, Act] : [0, 24, 24]
Active Time : 00:55
Sid : 7140
Admitted QoS Timeout : 200 seconds
Active QoS Timeout : 0 seconds
Packets : 1824
Bytes : 466944
Rate Limit Delayed Grants : 0
Rate Limit Dropped Grants : 0
Current Throughput : 68356 bits/sec, 32 packets/sec
Classifiers:
Classifier Id : 41
Service Flow Id : 30191
CM Mac Address : 000a.739e.140a
Direction : upstream
Activation State : active
Classifier Matching Priority : 128
PHSI : 1
Number of matches : -
IP Classification Parameters:
IP Source Address : 10.8.230.3
Source IP Address Mask : 255.255.255.255
Destination IP Address : 172.16.2.35
Destination IP Address Mask : 255.255.255.255
IP Protocol Type : 17
Source Port Low : 53456
Source Port High : 53456
Destination Port Low : 7052
Destination Port High : 7052
```

## Configuration Examples for L2VPN over Cable

This section provides configuration examples for the L2VPN over Cable feature:

### Example: Specifying the Ethernet NSI Interface

You can specify the Ethernet NSI within the CM configuration file, or using the **cable l2-vpn-service xconnect** global configuration command as shown in the following example:

```
cable l2-vpn-service xconnect nsi {dot1q|mpls}
```

## Example: Enabling Voice Call Support on MPLS L2VPN

The following is a sample cable modem configuration file that enables voice call support on MPLS L2VPN. In this example the L2VPN is applied to the primary service flow.

```

03 (Net Access Control)           = 1
18 (Maximum Number of CPE)       = 16
43 (Vendor Specific Options)
  S08 (Vendor ID)                 = ff ff ff
  S005 (Unknown sub-type)         = 01 04 32 30 32 30 02 07 04 05 01 0a 4c 02 01 2b 06 26 04
00 00 01 90
22 (Upstream Packet Classification Encoding Block)
  S01 (Classifier Reference)       = 2
  S03 (Service Flow Reference)    = 2
  S09 (IP Packet Encodings)
    T03 (IP Source Address)       = 050 001 005 000
    T04 (IP Source Mask)          = 255 255 255 000
22 (Upstream Packet Classification Encoding Block)
  S01 (Classifier Reference)       = 3
  S03 (Service Flow Reference)    = 2
  S10 (Ethernet LLC Packet Classification Encodings)
    T02 (Source MAC Address)      = 00 e0 f7 5a c9 21
23 (Downstream Packet Classification Encoding Block)
  S01 (Classifier Reference)       = 21
  S03 (Service Flow Reference)    = 21
  S05 (Rule Priority)              = 5
  S09 (IP Packet Encodings)
    T05 (IP Destination Address)  = 050 001 005 000
    T06 (IP Destination Mask)    = 255 255 255 000
23 (Downstream Packet Classification Encoding Block)
  S01 (Classifier Reference)       = 22
  S03 (Service Flow Reference)    = 21
  S05 (Rule Priority)              = 5
  S10 (Ethernet LLC Packet Classification Encodings)
    T01 (Destination MAC Address) = 00 e0 f7 5a c9 21 ff ff ff ff ff ff
24 (Upstream Service Flow Encodings)
  S01 (Service Flow Reference)    = 1
  S06 (QoS Parameter Set Type)    = 7
  S43 (Vendor Specific Options)
    T08 (Vendor ID)               = ff ff ff
    T005 (Unknown sub-type)       = 01 04 32 30 32 30
24 (Upstream Service Flow Encodings)
  S01 (Service Flow Reference)    = 2
  S06 (QoS Parameter Set Type)    = 7
25 (Downstream Service Flow Encodings)
  S01 (Service Flow Reference)    = 20
  S06 (QoS Parameter Set Type)    = 7
  S07 (Traffic Priority)           = 0
25 (Downstream Service Flow Encodings)
  S01 (Service Flow Reference)    = 21
  S06 (QoS Parameter Set Type)    = 7
  S07 (Traffic Priority)           = 1
29 (Privacy Enable)               = 1

```

## Example: Enabling Voice Call Support on 802.1q L2VPN

The following is a sample cable modem configuration file that enables voice call support on 802.1q L2VPN. In this example the L2VPN is applied to the secondary service flow.

```

03 (Net Access Control)           = 1

```

```

43 (Vendor Specific Options)
  S08 (Vendor ID) = ff ff ff
  S005 (Unknown sub-type) = 01 05 02 34 56 00 01 02 04 02 02 00 44
18 (Maximum Number of CPE) = 16
22 (Upstream Packet Classification Encoding Block)
  S01 (Classifier Reference) = 2
  S03 (Service Flow Reference) = 2
  S10 (Ethernet LLC Packet Classification Encodings)
    T02 (Source MAC Address) = 00 e0 14 e3 23 1c
23 (Downstream Packet Classification Encoding Block)
  S01 (Classifier Reference) = 4
  S03 (Service Flow Reference) = 4
  S43 (Vendor Specific Options)
    T08 (Vendor ID) = ff ff ff
    T005 (Unknown sub-type) = 01 05 02 34 56 00 01
  S11 (IEEE 802.1P/Q Packet Classification Encodings)
    T01 (IEEE 802.1P UserPriority) = 00 07
24 (Upstream Service Flow Encodings)
  S01 (Service Flow Reference) = 1
  S06 (QoS Parameter Set Type) = 7
24 (Upstream Service Flow Encodings)
  S01 (Service Flow Reference) = 2
  S06 (QoS Parameter Set Type) = 7
  S43 (Vendor Specific Options)
    T08 (Vendor ID) = ff ff ff
    T005 (Unknown sub-type) = 01 05 02 34 56 00 01 08 01 01
25 (Downstream Service Flow Encodings)
  S01 (Service Flow Reference) = 3
  S06 (QoS Parameter Set Type) = 7
25 (Downstream Service Flow Encodings)
  S01 (Service Flow Reference) = 4
  S06 (QoS Parameter Set Type) = 7

```

## Example: Enabling Voice Call Support on CLI-based L2VPN

The following is a sample cable modem configuration file that enables voice call support on L2VPN configured using CLI. L2VPN configured using the CLI is always applied to the primary service flow.

```

03 (Net Access Control) = 1
18 (Maximum Number of CPE) = 16
22 (Upstream Packet Classification Encoding Block)
  S01 (Classifier Reference) = 2
  S03 (Service Flow Reference) = 2
  S09 (IP Packet Encodings)
    T03 (IP Source Address) = 050 001 005 000
    T04 (IP Source Mask) = 255 255 255 000
22 (Upstream Packet Classification Encoding Block)
  S01 (Classifier Reference) = 3
  S03 (Service Flow Reference) = 2
  S10 (Ethernet LLC Packet Classification Encodings)
    T02 (Source MAC Address) = 00 e0 f7 5a c9 21
23 (Downstream Packet Classification Encoding Block)
  S01 (Classifier Reference) = 21
  S03 (Service Flow Reference) = 21
  S05 (Rule Priority) = 5
  S09 (IP Packet Encodings)
    T05 (IP Destination Address) = 050 001 005 000
    T06 (IP Destination Mask) = 255 255 255 000
23 (Downstream Packet Classification Encoding Block)
  S01 (Classifier Reference) = 22
  S03 (Service Flow Reference) = 21
  S05 (Rule Priority) = 5

```

```

S10 (Ethernet LLC Packet Classification Encodings)
    T01 (Destination MAC Address) = 00 e0 f7 5a c9 21 ff ff ff ff ff ff
24 (Upstream Service Flow Encodings)
    S01 (Service Flow Reference) = 1
    S06 (QoS Parameter Set Type) = 7
24 (Upstream Service Flow Encodings)
    S01 (Service Flow Reference) = 2
    S06 (QoS Parameter Set Type) = 77
25 (Downstream Service Flow Encodings)
    S01 (Service Flow Reference) = 20
    S06 (QoS Parameter Set Type) = 7
    S07 (Traffic Priority) = 0
25 (Downstream Service Flow Encodings)
    S01 (Service Flow Reference) = 21
    S06 (QoS Parameter Set Type) = 7
    S07 (Traffic Priority) = 1
29 (Privacy Enable) = 1

```

## Additional References

The following sections provide references related to the L2VPN Support over Cable feature.

### Standards

| Standard                 | Title                                                                                                                                                                                                                                                         |
|--------------------------|---------------------------------------------------------------------------------------------------------------------------------------------------------------------------------------------------------------------------------------------------------------|
| CM-SP-BPI+-I12-050812    | <i>Baseline Privacy Plus Interface Specification</i><br><a href="http://www.cablelabs.com/wp-content/uploads/specdocs/CM-SP-BPI+-C01-081104.pdf">http://www.cablelabs.com/wp-content/uploads/specdocs/CM-SP-BPI+-C01-081104.pdf</a>                           |
| CM-SP-L2VPN-I03-061222   | <i>Business Services over DOCSIS (BSOD) Layer 2 Virtual Private Networks</i><br><a href="http://www.cablelabs.com/wp-content/uploads/specdocs/CM-SP-L2VPN-I12-131120.pdf">http://www.cablelabs.com/wp-content/uploads/specdocs/CM-SP-L2VPN-I12-131120.pdf</a> |
| CM-SP-RFIV2.0-I11-060602 | <i>Radio Frequency Interface Specification</i><br><a href="http://www.cablelabs.com/wp-content/uploads/specdocs/CM-SP-RFIV2.0-C02-090422.pdf">http://www.cablelabs.com/wp-content/uploads/specdocs/CM-SP-RFIV2.0-C02-090422.pdf</a>                           |
| IEEE 802.1ad             | <i>IEEE 802.1ad-2005 IEEE Standards for Local and metropolitan area networks— Virtual Bridged Local Area Networks</i><br><a href="http://www.ieee.org">http://www.ieee.org</a>                                                                                |
| IEEE 802.1q              | <i>IEEE Std 802.1Q Virtual Bridged Local Area Networks</i><br><a href="http://www.ieee.org">http://www.ieee.org</a>                                                                                                                                           |

### MIBs

| MIB            | MIBs Link                                                                                                                                                                                                                                                       |
|----------------|-----------------------------------------------------------------------------------------------------------------------------------------------------------------------------------------------------------------------------------------------------------------|
| DOCS-L2VPN-MIB | To locate and download MIBs for selected platforms, Cisco IOS-XE releases, and feature sets, use Cisco MIB Locator found at the following URL:<br><a href="http://tools.cisco.com/ITDIT/MIBS/servlet/index">http://tools.cisco.com/ITDIT/MIBS/servlet/index</a> |

**RFCs**

| RFC      | Title                                                                                                                                       |
|----------|---------------------------------------------------------------------------------------------------------------------------------------------|
| RFC 2685 | Virtual Private Networks Identifier<br><a href="http://www.ietf.org/rfc/rfc2685.txt">http://www.ietf.org/rfc/rfc2685.txt</a>                |
| RFC 4364 | <i>BGP/MPLS IP Virtual Private Networks (VPNs)</i><br><a href="http://www.ietf.org/rfc/rfc4364.txt">http://www.ietf.org/rfc/rfc4364.txt</a> |

**Technical Assistance**

| Description                                                                                                                                                                                                                                                                                                                                                                           | Link                                                                                                              |
|---------------------------------------------------------------------------------------------------------------------------------------------------------------------------------------------------------------------------------------------------------------------------------------------------------------------------------------------------------------------------------------|-------------------------------------------------------------------------------------------------------------------|
| The Cisco Support and Documentation website provides online resources to download documentation, software, and tools. Use these resources to install and configure the software and to troubleshoot and resolve technical issues with Cisco products and technologies. Access to most tools on the Cisco Support and Documentation website requires a Cisco.com user ID and password. | <a href="http://www.cisco.com/cisco/web/support/index.html">http://www.cisco.com/cisco/web/support/index.html</a> |

## Feature Information for L2VPN Support over Cable

Use Cisco Feature Navigator to find information about the platform support and software image support. Cisco Feature Navigator enables you to determine which software images support a specific software release, feature set, or platform. To access Cisco Feature Navigator, go to the <https://cfng.cisco.com/> link. An account on the Cisco.com page is not required.



**Note** The following table lists the software release in which a given feature is introduced. Unless noted otherwise, subsequent releases of that software release train also support that feature.

**Table 195: Feature Information for L2VPN Support Over Cable**

| Feature Name             | Releases                    | Feature Information                                                                                              |
|--------------------------|-----------------------------|------------------------------------------------------------------------------------------------------------------|
| L2VPN support over cable | Cisco IOS XE Everest 16.6.1 | This feature was integrated into Cisco IOS XE Everest 16.6.1 on the Cisco cBR Series Converged Broadband Router. |







## CHAPTER 52

# L2VPN Over Port-Channel

The Layer 2 VPN (L2VPN) over port-channel feature supports IEEE 802.1Q (dot1q) L2VPN WAN interface port-channel. Using this feature, you can configure the dot1q L2VPN traffic to pass through port-channel uplink

### Contents

- [Information About L2VPN Over Port-Channel, on page 893](#)
- [How to Configure the L2VPN Over Port-Channel, on page 894](#)
- [Verifying Port-Channel Configuration, on page 894](#)
- [Feature Information for L2VPN Over Port-Channel, on page 895](#)

## Information About L2VPN Over Port-Channel

The Cisco cBR-8 supports L2VPN, where the Ethernet frames from the cable modem are cross connected to a specific VLAN interface. The VLAN ID to be inserted is specified. With the L2VPN over port-channel feature, you can now support port-channel uplink interface as well as the 10 Gb uplink interface.

### TLS L2VPN

For the Transparent LAN Service (TLS) L2VPN, the dot1q maps contain the cable modem MAC address, the VLAN ID, and the outbound interface. Traffic received from a specific cable modem is tagged with a VLAN ID and is sent out from the uplink interface.

### DOCSIS L2VPN

For the Data-over-Cable Service Interface Specifications (DOCSIS) L2VPN, cable modem (CM) configuration file holds the L2VPN encodings for both, the CM and the service flow. At the CMTS level you have to specify the default port-channel Network Side Interface (NSI). L2VPN encodings are passed by the CM to the CMTS during registration. The CMTS installs DOCSIS service flow VLAN mapping based on the information passed to it during the registration. For upstream traffic, the CMTS sends the dot1q VLAN tagged traffic out from the uplink interface. On downstream, the CMTS receives the dot1q tagged traffic from the aggregator. The CMTS replaces the VLAN header with a DOCSIS header to the corresponding service flow.

## Benefits of L2VPN Over Port-Channel

By using the dot1q L2VPN, you can utilize the port-channel interface feature instead of a single 10 Gb port.

## Restrictions for L2VPN Over Port-Channel

The CMTS dot1q L2VPN is designed to support traffic from customer premises equipment to the network or verse vice. For CMTS L2VPN NSI port, port-channel interface does not support VLAN redundancy.

## How to Configure the L2VPN Over Port-Channel

This section describes how to configure L2VPN over port-channel on the Cisco cBR-8.

### Configuring the Port-Channel Uplink Port for TLS L2VPN

For TLS L2VPN, you must configure the overall enable CLI and the dot1q map. In dot1q map, you have to designate the port-channel uplink port.

To configure the port-channel uplink port for TLS L2VPN, complete the following procedure:

```
cable l2-vpn-service xconnect nsi dot1q
cable dot1q-vc-map mac address port-channel number vlan id custom name
```

### Configuring the Port-Channel Uplink Port for DOCSIS L2VPN

For DOCSIS L2VPN, you only have to configure the overall enable CLI with port-channel uplink port. The other L2VPN related parameters are setup by the CM configuration file type-length-value parsing.

To configure the port-channel uplink port for DOCSIS L2VPN, complete the following procedure:

```
configure terminal
cable l2-vpn-service xconnect nsi dot1q interface port-channel number
```

## Verifying Port-Channel Configuration

### Verify the Port-Channel Mapping

To verify the port-channel mapping, use the **show cable l2-vpn xconnect dot1q-vc-map** command as shown in the example below:

```
show cable l2-vpn xconnect dot1q-vc-map
```

```
MAC Address      Ethernet Interface      VLAN ID  Cable Intf  SID  Customer Name/VPNID
c8fb.26a5.551c  Port-channel164        1200    Cable6/0/0  17   Topgun
```

### View the Port-Channel Interface

To view the port-channel interface, use the **show cable l2-vpn xconnect dot1q-vc-map verbose** command as shown in the example below:

```
show cable l2-vpn xconnect dot1q-vc-map c8fb.26a5.551c verbose
```

```
MAC Address                : c8fb.26a5.551c
Customer Name              : ats
Prim Sid                   : 17
Cable Interface            : Cable6/0/0
Ethernet Interface         : Port-channel164
DOT1Q VLAN ID             : 1200
Total US pkts              : 189
Total US bytes             : 18200
Total DS pkts              : 615
Total DS bytes             : 39360
```

## Feature Information for L2VPN Over Port-Channel

*Table 196: Feature Information for L2VPN Over Port-Channel*

| Feature Name            | Releases                    | Feature Information                                                                                              |
|-------------------------|-----------------------------|------------------------------------------------------------------------------------------------------------------|
| L2VPN over port-channel | Cisco IOS XE Everest 16.6.1 | This feature was integrated into Cisco IOS XE Everest 16.6.1 on the Cisco cBR Series Converged Broadband Router. |





## CHAPTER 53

# MPLS Pseudowire for Cable L2VPN

The Multiprotocol Label Switching (MPLS) Pseudowire for Cable Layer 2 Virtual Private Network (L2VPN) feature enables service providers to use a single, converged, Internet Protocol (IP)/MPLS network infrastructure to offer Ethernet data link layer (Layer 2) connectivity to two or more VPN customer sites.

- [Finding Feature Information, on page 897](#)
- [Hardware Compatibility Matrix for the Cisco cBR Series Routers, on page 898](#)
- [Prerequisites for MPLS Pseudowire for Cable L2VPN, on page 899](#)
- [Restrictions for MPLS Pseudowire for Cable L2VPN, on page 899](#)
- [Information About MPLS Pseudowire for Cable L2VPN, on page 900](#)
- [L2VPN Pseudowire Redundancy, on page 903](#)
- [MPLS Pseudowire Provisioning Methods, on page 903](#)
- [How to Enable MPLS on a Cisco CMTS Router, on page 908](#)
- [How to Provision MPLS Pseudowires, on page 912](#)
- [How to Configure L2VPN Pseudowire Redundancy, on page 913](#)
- [Configuration Examples for MPLS Pseudowire for Cable L2VPN, on page 916](#)
- [Verifying the MPLS Pseudowire Configuration, on page 923](#)
- [Additional References, on page 926](#)
- [Feature Information for MPLS Pseudowire for Cable L2VPN, on page 927](#)

## Finding Feature Information

Your software release may not support all the features that are documented in this module. For the latest feature information and caveats, see the release notes for your platform and software release. The Feature Information Table at the end of this document provides information about the documented features and lists the releases in which each feature is supported.

Use Cisco Feature Navigator to find information about platform support and Cisco software image support. To access Cisco Feature Navigator, go to <http://tools.cisco.com/ITDIT/CFN/>. An account on <http://www.cisco.com/> is not required.

# Hardware Compatibility Matrix for the Cisco cBR Series Routers



**Note** The hardware components that are introduced in a given Cisco IOS-XE Release are supported in all subsequent releases unless otherwise specified.

**Table 197: Hardware Compatibility Matrix for the Cisco cBR Series Routers**

| Cisco CMTS Platform                    | Processor Engine                                                                                                                                                                                  | Interface Cards                                                                                                                                                                                                                                                                                                                                                                                                                                                                                                                                                                                                                                                                                                                                                                                 |
|----------------------------------------|---------------------------------------------------------------------------------------------------------------------------------------------------------------------------------------------------|-------------------------------------------------------------------------------------------------------------------------------------------------------------------------------------------------------------------------------------------------------------------------------------------------------------------------------------------------------------------------------------------------------------------------------------------------------------------------------------------------------------------------------------------------------------------------------------------------------------------------------------------------------------------------------------------------------------------------------------------------------------------------------------------------|
| Cisco cBR-8 Converged Broadband Router | <p><b>Cisco IOS-XE Release 16.5.1 and Later Releases</b></p> <p>Cisco cBR-8 Supervisor:</p> <ul style="list-style-type: none"> <li>• PID—CBR-SUP-250G</li> <li>• PID—CBR-CCAP-SUP-160G</li> </ul> | <p><b>Cisco IOS-XE Release 16.5.1 and Later Releases</b></p> <p>Cisco cBR-8 CCAP Line Cards:</p> <ul style="list-style-type: none"> <li>• PID—CBR-LC-8D30-16U30</li> <li>• PID—CBR-LC-8D31-16U30</li> <li>• PID—CBR-RF-PIC</li> <li>• PID—CBR-RF-PROT-PIC</li> <li>• PID—CBR-CCAP-LC-40G</li> <li>• PID—CBR-CCAP-LC-40G-R</li> <li>• PID—CBR-CCAP-LC-G2-R</li> <li>• PID—CBR-SUP-8X10G-PIC</li> <li>• PID—CBR-2X100G-PIC</li> </ul> <p>Digital PICs:</p> <ul style="list-style-type: none"> <li>• PID—CBR-DPIC-8X10G</li> <li>• PID—CBR-DPIC-2X100G</li> </ul> <p>Cisco cBR-8 Downstream PHY Module:</p> <ul style="list-style-type: none"> <li>• PID—CBR-D31-DS-MOD</li> </ul> <p>Cisco cBR-8 Upstream PHY Modules:</p> <ul style="list-style-type: none"> <li>• PID—CBR-D31-US-MOD</li> </ul> |



---

**Note** Do not use DPICs (8X10G and 2x100G) to forward IP traffic, as it may cause buffer exhaustion, leading to line card reload.

The only allowed traffic on a DPIC interface is DEPI, UEPI, and GCP traffic from the Cisco cBR-8 router to Remote PHY devices. Other traffic such as DHCP, SSH, and UTSC should flow via another router, since DPICs cannot be used for normal routing.

---

## Prerequisites for MPLS Pseudowire for Cable L2VPN

- Enable Baseline Privacy Interface Plus (BPI+) to provide a simple data encryption scheme to protect data sent to and from cable modems in a data over cable network.
- Enable Cisco Express Forwarding (CEF) to optimize network performance.
- Ensure that the primary and backup pseudowires on the remote provider edge (PE) routers have the same pseudowire type as the Cisco cable modem termination system (CMTS).
- Create the remote pseudowire using a pw-class with VLAN as the interworking for remote PEs, if the CMTS is using VLAN as pseudowire type.

## Restrictions for MPLS Pseudowire for Cable L2VPN

The following are the general restrictions for the MPLS Pseudowire for Cable L2VPN feature:

- Supports only Ethernet over MPLS (EoMPLS) pseudowires per RFC 4448.
- Supports only point-to-point forwarding. Ethernet switching is not supported.
- Requires DOCSIS 2.0, 3.0 and 3.1-certified cable modems (CMs). This feature is not supported on DOCSIS 1.0-certified cable modems.
- Supports a maximum of four VPNs per cable modem.
- Supports a maximum of eight upstream service flows and eight downstream classifiers.
- Supports a maximum of 16000 EoMPLS pseudowires per Cisco CMTS router.
- Requires the backup pseudowire to be up on the remote PE for the Cisco CMTS to switchover.
- Requires the backup pseudowire to become active on the Cisco CMTS only after the primary pseudowire fails.
- Supports 2000 Bytes MTU (default value) on remote interface for DOCSIS 3.1 cable modem.



---

**Note** The CLI-based (static provisioning) L2VPN supports traffic forwarding to VPN only on primary upstream and downstream service flows. Hence only primary upstream and downstream service flows must be configured in the cable modem configuration file.

---

# Information About MPLS Pseudowire for Cable L2VPN

The MPLS Pseudowire for Cable L2VPN feature enables Ethernet-based Layer 2 VPN service over an MPLS network by encapsulating and transmitting the Layer 2 protocol data units (PDUs) over pseudowires (PWs). This feature enables service providers to offer site-to-site connectivity to their business and enterprise customers.

Layer 2 services emulated over an MPLS network are commonly referred to as MPLS-based L2VPNs or MPLS L2VPNs. Subsequently, Ethernet service emulated over an MPLS network is referred to as Ethernet over MPLS (EoMPLS) service.

The MPLS Pseudowire for Cable L2VPN feature is fully compliant with CableLabs Business Services over DOCSIS (BSOD) L2VPN specification, and is an extension to the existing DOCSIS L2VPN features supported on Cisco CMTS routers.

The MPLS Pseudowire for Cable L2VPN feature provides the following capabilities:

- Supports 2000 Bytes MTU (default value) on remote interface for DOCSIS 3.1 cable modems.
- Transport Ethernet frames over an MPLS network.
- Handle a DOCSIS service flow as an attachment circuit that is mapped to an EoMPLS pseudowire.
- Enable the Cisco CMTS router to be the MPLS provider edge (PE) router.
- Enable forwarding of Ethernet frames over DOCSIS (between a CM and a Cisco CMTS router) to MPLS (towards Metropolitan Area Network or Wide Area Network).
- Provide a common framework to encapsulate and transport supported Layer 2 traffic types over an MPLS network.

The MPLS Pseudowire for Cable L2VPN feature differs from the existing DOCSIS L2VPN features such as 802.1q-based L2VPN (L2VPN Support over Cable). The MPLS Pseudowire for Cable L2VPN feature uses IP/MPLS network to transport layer 2 protocol data units (PDUs), whereas 802.1q-based L2VPN feature uses layer 2 Ethernet network to transport PDUs.

## How MPLS Transports Layer 2 Packets

The MPLS subsystem removes DOCSIS encapsulation for Layer 2 Ethernet frames and adds MPLS labels at the ingress provider edge (PE) Cisco CMTS router. Then, the MPLS subsystem sends resulting MPLS packets to the corresponding PE router at the other end of the pseudowire. The PE routers must be configured for successful transmission of IP/MPLS packets between the two PE routers.

The cable modem classifies Ethernet frames from the customer premise equipment (CPE) in the upstream direction using upstream classifiers. Then, a DOCSIS header is added to these frames, and they are sent on a given upstream service flow with a different service identifier. On the Cisco CMTS router, the upstream packet is classified as an L2VPN packet based on the cable interface and service identifier. The Cisco CMTS router removes the DOCSIS header and adds an MPLS header. An MPLS header contains two MPLS labels: the outer label corresponding to the remote PE router and the inner label corresponding to the pseudowire label. The Cisco CMTS router forwards the MPLS packet towards the remote PE router, which is the other end of the pseudowire, over the MPLS network.

In the downstream direction, the Cisco CMTS router receives MPLS packets having only one MPLS header that contains the label that the Cisco CMTS router previously allocated for the corresponding EoMPLS pseudowire. The Cisco CMTS router uses the MPLS label to identify one of the L2VPN cable modems. Then,



the Cisco CMTS router classifies the MPLS packet using the L2VPN downstream classifiers based on MPLS experimental (MPLS-EXP) bits in the MPLS header of the received MPLS packet, and removes the MPLS header. Then, the Cisco CMTS router sends the packet on the classified downstream service flow by adding the DOCSIS header. The cable modem then removes the DOCSIS header and delivers the Ethernet frame to the CPE.

A unique combination of a cable modem MAC address, VPN ID (if present in the CM configuration file), peer IP address, and a virtual circuit ID (VCID) identifies the MPLS pseudowire on the Cisco CMTS router.

Figure 28: Transporting Layer 2 Packets

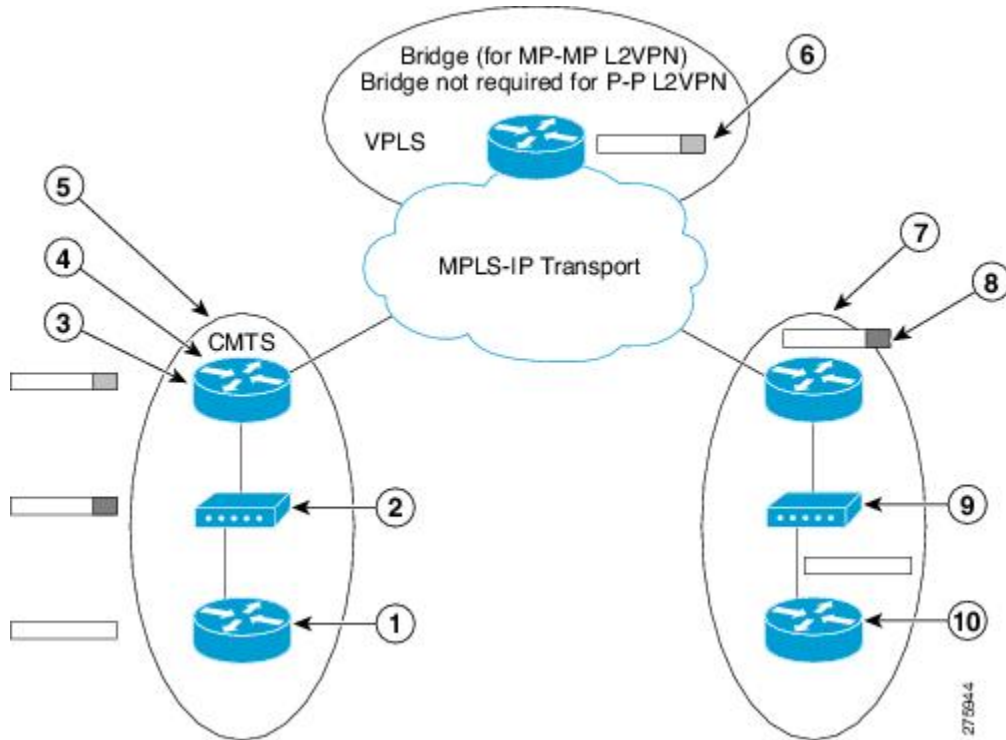

The table illustrates how MPLS transports Layer 2 packets in a DOCSIS-based cable communications system.

|   |                                                                                                                                    |    |                                                                                                                                |
|---|------------------------------------------------------------------------------------------------------------------------------------|----|--------------------------------------------------------------------------------------------------------------------------------|
| 1 | A router sends an untagged Ethernet frame.                                                                                         | 6  | MPLS packets are label switched.                                                                                               |
| 2 | A CM adds a DOCSIS header to the frame.                                                                                            | 7  | The Cisco CMTS router receives an MPLS packet and looks up the MPLS forwarding table using the label value in the MPLS header. |
| 3 | The Cisco CMTS router removes the DOCSIS header from the frame.                                                                    | 8  | The Cisco CMTS router replaces the MPLS header with DOCSIS header (containing the right SID value).                            |
| 4 | The Cisco CMTS router looks up the Service ID (SID) database using the SID value from the DOCSIS header and finds the MPLS header. | 9  | The DOCSIS header is removed.                                                                                                  |
| 5 | The Cisco CMTS router adds the MPLS header to the frame.                                                                           | 10 | The Ethernet frame is delivered untagged.                                                                                      |

## Supported Ethernet Encapsulation on UNI

The Ethernet User-Network Interface (UNI) is the connection between a cable modem and a customer premise equipment such as a router or a switch. The service provider may or may not use any encapsulation on the UNI.

The MPLS Pseudowire for Cable L2VPN feature supports the following transport types on an Ethernet UNI:

- Port-based UNI (independent of any VLAN)—The port-based UNI provides Metro Ethernet Forum (MEF)-defined Ethernet Private Line (EPL) service. In this transport type, an MPLS pseudowire is mapped to the Ethernet port.
- VLAN-based UNI—Ethernet VLAN using 802.1q encapsulation (including stacked VLANs). The VLAN-based UNI provides MEF-defined Ethernet Virtual Private Line (EVPL) service. In this transport type, the MPLS pseudowire is mapped to the 802.1q VLAN.



---

**Note** The Ethernet UNI must be attached to the Ethernet port of a cable modem.

---

Before configuring this feature, you should understand the following concepts:

## MPLS Pseudowire

Pseudowire is a point-to-point Layer 2 connection between two PE routers. The MPLS Pseudowire for Cable L2VPN feature supports the following pseudowire types:

- Type-4 pseudowire—This is used to transport only VLAN tagged Layer 2 Ethernet frames.
- Type-5 pseudowire—This is used to transport VLAN tagged and untagged Layer 2 Ethernet frames. This is the default pseudowire type.

## Bundle254 Interface

The bundle254 (Bu254) interface is an internal bundle interface on a Cisco CMTS router that is used as a circuit identifier for all MPLS pseudowires. This internal bundle interface is created automatically on a Cisco CMTS router when you enable the MPLS pseudowire functionality using the **cable l2-vpn-service xconnect** command. Only one Bu254 interface is created to handle all the MPLS pseudowires available on the Cisco CMTS router.

The output of the **show xconnect** or **show cable l2-vpn xconnect** command displays the circuit identifier created by the Cisco CMTS router for all the MPLS pseudowires.

## Ingress Process

When an upstream packet received from a cable interface of the Cisco CMTS router is identified as an L2VPN packet based on the cable modem interface and Service ID (SID), the packet goes through the ingress process. The ingress process ensures that the DOCSIS header is removed, and an MPLS label header is added to the packet according to the MPLS pseudowire configuration and the packet is sent out from the Ethernet interface of the Cisco CMTS router. The ingress process is also known as the label imposition process.

## Egress Process

When a downstream packet received from an Ethernet interface of the Cisco CMTS router is identified as an L2VPN packet by the innermost MPLS label, the packet goes through the egress process. The egress process ensures that the MPLS label header is deleted from the packet and the DOCSIS header is added to the packet. Then the packet is sent out from the cable interface of the Cisco CMTS router. The egress process is also known as the label disposition process.

## MPLS Pseudowire Control Plane Process

When an L2VPN-compliant CM registers with a Cisco CMTS router and conveys the L2VPN related parameters to the router, the router follows the standard Label Distribution Protocol (LDP) procedures to set up an Ethernet over MPLS pseudowire with the remote PE router. When the L2VPN-compliant CM goes offline, the Cisco CMTS router brings down the pseudowire as well. If the Cisco CMTS router has no L2VPN-compliant CM registered, then the router tears down the targeted LDP session with the remote PE router.

## L2VPN Pseudowire Redundancy

The L2VPN Pseudowire Redundancy feature enables a PE router to detect a pseudowire failure and reroute the Layer 2 service to a backup pseudowire that can continue to provide the service. The pseudowire redundancy can be implemented with either Cisco CMTS or a generic router as the PE router. When the primary pseudowire recovers from the failure, the L2VPN Pseudowire Redundancy feature provides the option to bring back the Layer 2 service to the primary pseudowire.

Each primary pseudowire can have up to three backup pseudowires, with unique priorities. For example, priority one cannot be given to two different pseudowires in the backup list. When the primary pseudowire goes down, the Cisco CMTS sends the traffic to the backup pseudowire with the highest priority. For a successful service transfer, the remote state of the backup pseudowire should already be 'up'. Only the local state of the active pseudowire will be 'up' when the modem is BPI online. Similarly, if the backup pseudowire is in use, the local state of only that backup pseudowire will be 'up'.

If the active backup pseudowire goes down, the Cisco CMTS will use the next highest backup pseudowire whose remote state is 'up'. However, the Cisco CMTS will not switchover from the lower priority pseudowire to the higher priority pseudowire when the backup pseudowire with the highest priority comes 'up'. This is to prevent unnecessary switchovers between the backup pseudowires.

When the primary pseudowire recovers from the failure, the L2VPN Pseudowire Redundancy feature brings back the service to the primary pseudowire, after waiting for the time period set using the backup delay command. The local state of the active backup pseudowire will be marked as 'down' after the primary pseudowire comes up.

## MPLS Pseudowire Provisioning Methods

The MPLS Pseudowire for Cable L2VPN feature supports the following provisioning methods for pseudowires:



---

**Note** Before performing the static or dynamic provisioning of MPLS pseudowires, you must enable MPLS on a Cisco CMTS router. For details on the tasks required to enable MPLS, see the [How to Enable MPLS on a Cisco CMTS Router](#).

---

## Static Provisioning Method for MPLS Pseudowires

The static provisioning method requires the MPLS pseudowire to be statically provisioned on the CMTS using the command line interface (CLI). This type of provisioning does not require the CM configuration file to use BSOD L2VPN-compliant TLVs. For details on how to statically provision MPLS pseudowires, see the *Static Provisioning of MPLS Pseudowires*.

## Dynamic Provisioning Method for MPLS Pseudowires

The dynamic provisioning method is a CM configuration file-based provisioning method and is the recommended provisioning method for creating MPLS pseudowires. For details on how to dynamically provision MPLS pseudowires, see the [Dynamic Provisioning of MPLS Pseudowires, on page 912](#).

The following are the benefits of dynamic provisioning of pseudowires:

- Multiple VPNs can be specified in a CM configuration file and a pseudowire can be provisioned for each VPN.
- Multiple upstream service flows and downstream classifiers can be associated with each VPN.
- Each upstream service flow can be tagged to an MPLS experimental (EXP) level for the egress WAN traffic.
- Downstream ingress WAN traffic can be classified based on the downstream MPLS-EXP range specified in each downstream classifier.
- The Cisco CMTS router will have finer control of MPLS quality of service (QoS) over cable and WAN interfaces.

For dynamic provisioning of MPLS pseudowires, you use an L2VPN-compliant CM configuration file that is stored on the Trivial File Transfer Protocol (TFTP) server. You use a common CM configuration file editor such as CableLabs Config File Editor, or a sophisticated provisioning backend system such as Broadband Access Center for Cable (BACC) to create CM configuration files.

This provisioning method requires the usage of CableLabs defined L2VPN encodings such as type, length, value (TLV) objects in the CM configuration file. These L2VPN encodings control L2VPN forwarding of upstream and downstream Ethernet frames.

You can specify the L2VPN encodings in the following ways:

- Per CM
- Per downstream classifier
- Per service flow
- Per upstream classifier



---

**Note** The CM L2VPN encoding is mandatory.

---

The CM L2VPN encoding contains many TLVs, out of which the two most important TLVs are VPN Identifier and NSI Encapsulation. To configure an MPLS pseudowire, you must set the NSI Encapsulation to MPLS. The other TLVs are used to specify the pseudowire identifiers in the form of source attachment individual identifier (SAII), target attachment individual identifier (TAII), and attachment group identifier (AGI).

The L2VPN encoding parameter is encoded as a general extension information (GEI) parameter in the CM configuration file. This indicates that the parameter is encoded as a subtype of the vendor-specific information type parameter using the vendor ID (0xFFFFFFFF).

The table lists the important CableLabs defined TLVs that are used at the top level of the CM configuration file for the MPLS Pseudowire for Cable L2VPN feature. See the BSOD specification, *Business Services over DOCSIS (BSOD) Layer 2 Virtual Private Networks*, from CableLabs for a complete list of CableLabs defined TLVs.

**Table 198: CableLabs Defined L2VPN TLVs**

| TLV Name                                     | Type   | Length  | Value and Description                                                                                                                                                                                                                                                                                                                                                                                                                                                                       |
|----------------------------------------------|--------|---------|---------------------------------------------------------------------------------------------------------------------------------------------------------------------------------------------------------------------------------------------------------------------------------------------------------------------------------------------------------------------------------------------------------------------------------------------------------------------------------------------|
| Downstream Unencrypted Traffic (DUT) Control | 45.1   | 1       | Bit 0 DUT Filtering<br>DUT Filtering = 0: Disable (default)<br>DUT Filtering = 1: Enable DUT Filtering                                                                                                                                                                                                                                                                                                                                                                                      |
| Downstream Unencrypted Traffic (DUT) CMIM    | 45.2   | N       | DUT CMIM (optional)<br>CM Interface Mask (CMIM) limiting outgoing interfaces of DUT traffic. If the DUT CMIM is omitted, its default value includes the eCM and all implemented eSAFE interfaces, but not any CPE interfaces.                                                                                                                                                                                                                                                               |
| VPN Identifier                               | 43.5.1 | 1 to N  | An opaque octet string that identifies an L2VPN. N is vendor-specific, and the valid range is from 6 to 255.                                                                                                                                                                                                                                                                                                                                                                                |
| NSI Encapsulation Subtype                    | 43.5.2 | n       | A single NSI encapsulation format code/length/value tuple. This TLV uses any of the following values:<br>NSI encapsulation = 0 : Other<br>NSI encapsulation = 1 : IEEE 802.1Q (specify VLAN ID)<br>NSI encapsulation = 2 : IEEE 802.1AD (specify Q-in-Q)<br>NSI encapsulation = 3 : MPLS peer (specify IPv4 or IPv6 address)<br>The value must be set to 3 to ensure MPLS pseudowire usage. The address must identify the remote PE (by its IP address assigned to the loopback interface). |
| Attachment Group ID                          | 43.5.5 | 0 to 16 | Opaque byte string that identifies the CM or SF as an attachment circuit for IETF Layer 2 VPN signaling protocols.                                                                                                                                                                                                                                                                                                                                                                          |
| Source Attachment Individual ID              | 43.5.6 | 0 to 16 | Opaque byte string signaled as SAII circuit for IETF Layer 2 VPN signaling protocols.                                                                                                                                                                                                                                                                                                                                                                                                       |
| Target Attachment Individual ID              | 43.5.7 | 0 to 16 | Opaque byte string that identifies the CM or SF as an attachment circuit for IETF Layer 2 VPN signaling protocols.                                                                                                                                                                                                                                                                                                                                                                          |
| Ingress User Priority                        | 43.5.8 | 1       | Ingress IEEE 802.1 user priority value in the range of 0 to 7 encoded in the least significant three bits. Higher values indicate higher priority.                                                                                                                                                                                                                                                                                                                                          |

| TLV Name            | Type   | Length | Value and Description                                                                                                                                                                                                           |
|---------------------|--------|--------|---------------------------------------------------------------------------------------------------------------------------------------------------------------------------------------------------------------------------------|
| User Priority Range | 43.5.9 | 2      | The lower user priority value of the user priority range is encoded in the least significant three bits of the first byte, and the higher value of the range is encoded in the least significant three bits of the second byte. |

## Cisco-Specific L2VPN TLVs

Even though CableLabs defined L2VPN TLVs are sufficient for dynamic provisioning of MPLS pseudowires, CMTS operators can use Cisco-specific TLVs at the top level of the CM configuration file to enable additional functions.

This table lists the new Cisco-specific TLVs that are defined for the MPLS Pseudowire for Cable L2VPN feature.

**Table 199: Cisco-Specific L2VPN TLVs**

| TLV Name      | Type       | Length | Value                                                                                                            | Description                                                                                                                                                                                                                                                                                                                                                                                                                 |
|---------------|------------|--------|------------------------------------------------------------------------------------------------------------------|-----------------------------------------------------------------------------------------------------------------------------------------------------------------------------------------------------------------------------------------------------------------------------------------------------------------------------------------------------------------------------------------------------------------------------|
| MPLS-PW-TYPE  | 43.5.43.36 | 1      | <ul style="list-style-type: none"> <li>• 4 = Type-4 Ethernet VLAN</li> <li>• 5 = Type-5 Ethernet port</li> </ul> | The Cisco CMTS router interprets this subtype as MPLS pseudowire type (Type-4 or Type-5). If this TLV value is not specified, then the router accepts the default value (5) for Type-5.                                                                                                                                                                                                                                     |
| MPLS-VCID     | 43.5.43.38 | 4      | 4 bytes unsigned number = MPLS VCID                                                                              | <p>This subtype is interpreted as MPLS VCID.</p> <p>This TLV is ignored, and the value of TAIL is used as VCID for the pseudowire, if the following conditions are met:</p> <ul style="list-style-type: none"> <li>• The CableLabs BSOD specification-compliant TLVs, SAIL and TAIL, are present in the CM configuration file.</li> <li>• Both are of 4 bytes length.</li> <li>• Value of SAIL is equal to TAIL.</li> </ul> |
| MPLS-PEERNAME | 43.5.43.39 | N      | ASCII encoded data                                                                                               | The Cisco CMTS router interprets this optional subtype as MPLS peer name in ASCII encoded data.                                                                                                                                                                                                                                                                                                                             |

This table lists the new Cisco-specific type, length, values (TLVs) that are defined for the L2VPN Pseudowire Redundancy feature.

**Table 200: Cisco-Specific L2VPN TLVs for Pseudowire Redundancy**

| TLV Name      | Type         | Length | Value                                | Description                                                                                                                                                  |
|---------------|--------------|--------|--------------------------------------|--------------------------------------------------------------------------------------------------------------------------------------------------------------|
| BACKUP-PW     | 45.5.43.40   | N      | Backup pseudowire related parameters | The Cisco CMTS router interprets this subtype as related parameters for the MPLS backup pseudowire. This TLV indicates the start of a new backup pseudowire. |
| BACKUP-PEERIP | 43.5.43.40.1 | 4      | IP address of the backup peer (IPv4) | The Cisco CMTS router interprets this optional subtype as the peer IP address of the MPLS backup pseudowire. This TLV is an IPv4 address.                    |

| TLV Name             | Type         | Length | Value                                                       | Description                                                                                                                                                                                                                                                                                                                                                                                                                                                                   |
|----------------------|--------------|--------|-------------------------------------------------------------|-------------------------------------------------------------------------------------------------------------------------------------------------------------------------------------------------------------------------------------------------------------------------------------------------------------------------------------------------------------------------------------------------------------------------------------------------------------------------------|
| BACKUP-PEERNAME      | 43.5.43.40.2 | N      | ASCII encoded data                                          | The Cisco CMTS router interprets this optional subtype as the MPLS backup peer name in ASCII encoded data.<br><br>This TLV is resolved to IPv4 address through DNS.                                                                                                                                                                                                                                                                                                           |
| BACKUP-MPLS-VCID     | 43.5.43.40.3 | 4      | 4 bytes unsigned number = MPLS VCID for backup pseudowire   | The Cisco CMTS router interprets this subtype as the VCID of the backup pseudowire.<br><br>This TLV is ignored, and the value of TAIL is used as the VCID for the pseudowire, if the following conditions are met: <ul style="list-style-type: none"> <li>• The CableLabs BSOD specification-compliant TLVs, SAIL, and TAIL, are present in the CM configuration file.</li> <li>• SAIL, and TAIL are of 4 bytes length.</li> <li>• Value of SAIL is equal to TAIL.</li> </ul> |
| BACKUP-MPLS-PRIORITY | 43.5.43.40.4 | 1      | 1 byte unsigned number = priority for the backup pseudowire | The Cisco CMTS router interprets this subtype as the MPLS priority.<br><br>Each primary pseudowire can have up to three backup pseudowires, with unique priorities. The priority indicates the order in which the CMTS should switch to the backup peer when the primary peer is down.                                                                                                                                                                                        |
| BACKUP-ENABLE-DELAY  | 43.5.43.41   | 1      | 1 byte unsigned number = number of seconds                  | The Cisco CMTS router interprets this subtype as the number of seconds the backup pseudowire should wait to take over after the primary pseudowire goes down.<br><br>If the TLV value is not specified, then the router uses the default value of 0 seconds.                                                                                                                                                                                                                  |
| BACKUP-DISABLE-DELAY | 43.5.43.42   | 1      | 1 byte unsigned number = number of seconds                  | The Cisco CMTS router interprets this subtype as the number of seconds the primary pseudowire should wait to take over after the remote state of the primary pseudowire comes up.<br><br>If the TLV value is not specified, then the router uses the default value of 0 seconds.                                                                                                                                                                                              |
| BACKUP-DISABLE-NEVER | 43.5.43.43   | 1      | 1 byte unsigned number = never disable backup pseudowire    | The Cisco CMTS router interprets this subtype as a flag indicating that the backup pseudowire should not be disabled even after the primary pseudowire comes up.<br><br>If this TLV is not present, the router takes the default action of reverting back to the primary pseudowire.                                                                                                                                                                                          |

# How to Enable MPLS on a Cisco CMTS Router

Perform the following tasks in the same order to enable MPLS on a Cisco CMTS router:



---

**Note** Before performing the static or dynamic provisioning of MPLS pseudowires, you must enable MPLS on a Cisco CMTS router.

---

## Configuring an LDP Router ID

The **mpls ldp router-id** command allows you to assign an interface IP address as the LDP router ID.

The normal process to determine the LDP router ID is as follows:

1. The router considers all the IP addresses of all operational interfaces.
2. If these addresses include loopback interface addresses, the router selects the largest loopback address. Configuring a loopback address helps ensure a stable LDP ID for the router, because the state of loopback addresses does not change. However, configuring a loopback interface and IP address on each router is not required.

The loopback IP address is not considered as the router ID of the local LDP ID under the following circumstances:

1. If the loopback interface has been explicitly shut down.
2. If the **mpls ldp router-id** command specifies that a different interface should be used as the LDP router ID.
3. If you use a loopback interface, make sure that the IP address for the loopback interface is configured with a /32 network mask. In addition, ensure that the routing protocol in use is configured to advertise the corresponding /32 network. Otherwise, the router selects the largest interface address.

The router might select a router ID that is not usable in certain situations. For example, the router might select an IP address that the routing protocol cannot advertise to a neighboring router. The router implements the router ID the next time it is necessary to select an LDP router ID. The effect of the **mpls ldp router-id** command is delayed until it is necessary to select an LDP router ID, which is the next time the interface is shut down or the address is deconfigured.

If you use the **force** keyword with the **mpls ldp router-id** command, the router ID takes effect more quickly. However, implementing the router ID depends on the current state of the specified interface:

- If the interface is up (operational) and its IP address is not currently the LDP router ID, the LDP router ID is forcibly changed to the IP address of the interface. This forced change in the LDP router ID tears down any existing LDP sessions, releases label bindings learned via the LDP sessions, and interrupts MPLS forwarding activity associated with the bindings.
- If the interface is down, the LDP router ID is forcibly changed to the IP address of the interface when the interface transitions to up. This forced change in the LDP router ID tears down any existing LDP sessions, releases label bindings learned via the LDP sessions, and interrupts MPLS forwarding activity associated with the bindings.

### Before you begin

Ensure that the specified interface is operational before assigning it as the LDP router ID.



## Procedure

|               | Command or Action                                                                                                                            | Purpose                                                                                   |
|---------------|----------------------------------------------------------------------------------------------------------------------------------------------|-------------------------------------------------------------------------------------------|
| <b>Step 1</b> | <b>enable</b><br><b>Example:</b><br><br>Router> enable                                                                                       | Enables privileged EXEC mode.<br><br>• Enter your password if prompted.                   |
| <b>Step 2</b> | <b>configure terminal</b><br><b>Example:</b><br><br>Router# configure terminal                                                               | Enters global configuration mode.                                                         |
| <b>Step 3</b> | <b>mpls ip</b><br><b>Example:</b><br><br>Router(config)# mpls ip                                                                             | Enables the dynamic MPLS forwarding function on the specified Gigabit Ethernet interface. |
| <b>Step 4</b> | <b>mpls ldp router-id loopback interface-number [force]</b><br><b>Example:</b><br><br>Router(config)# mpls ldp router-id loopback 2030 force | Specifies the IP address of the loopback interface as the LDP router ID.                  |
| <b>Step 5</b> | <b>exit</b><br><b>Example:</b><br><br>Router(config)# exit                                                                                   | Exits global configuration mode and enters privileged EXEC mode.                          |

## Configuring MPLS on a Gigabit Ethernet Interface

MPLS forwarding and Label Distribution Protocol must be enabled on 1-port or 10-port GE interfaces of the Cisco CMTS router to ensure that the router establishes MPLS label-switched path (LSP) to the remote PE routers. This section explains how to enable MPLS forwarding and LDP on a Gigabit Ethernet interface.



**Note** Configuration steps are similar for 1-port and 10-port GE interfaces.

## Procedure

|               | Command or Action                                      | Purpose                                                                 |
|---------------|--------------------------------------------------------|-------------------------------------------------------------------------|
| <b>Step 1</b> | <b>enable</b><br><b>Example:</b><br><br>Router> enable | Enables privileged EXEC mode.<br><br>• Enter your password if prompted. |

|               | Command or Action                                                                                                            | Purpose                                                                                   |
|---------------|------------------------------------------------------------------------------------------------------------------------------|-------------------------------------------------------------------------------------------|
| <b>Step 2</b> | <b>configure terminal</b><br><b>Example:</b><br><br>Router# configure terminal                                               | Enters global configuration mode.                                                         |
| <b>Step 3</b> | <b>interface gigabitethernet slot/subslot/port</b><br><b>Example:</b><br><br>Router(config)# interface gigabitethernet 3/0/0 | Enters interface cable configuration mode and specifies the Gigabit Ethernet interface.   |
| <b>Step 4</b> | <b>mpls ip</b><br><b>Example:</b><br><br>Router(config-if)# mpls ip                                                          | Enables the dynamic MPLS forwarding function on the specified Gigabit Ethernet interface. |
| <b>Step 5</b> | <b>end</b><br><b>Example:</b><br><br>Router(config-if)# end                                                                  | Exits interface cable configuration mode and enters privileged EXEC mode.                 |

## Configuring an MPLS Label Distribution Protocol

The MPLS label distribution protocol (LDP) allows the construction of highly scalable and flexible IP VPNs that support multiple levels of services. This section explains how to configure an MPLS label distribution protocol on a Gigabit Ethernet interface.

MPLS LDP graceful-restart may also be configured for faster L2VPN traffic recovery after a LDP session disruption. For more information see the [MPLS LDP Graceful Restart](#) guide.



**Note** Ensure that the loopback interface with the IP address is present on each PE router using the **show ip interface brief** command before configuring an MPLS label distribution protocol. This loopback interface identifies the Cisco CMTS router as the peer IP address of the pseudowire.

### Procedure

|               | Command or Action                | Purpose                                                                                                            |
|---------------|----------------------------------|--------------------------------------------------------------------------------------------------------------------|
| <b>Step 1</b> | <b>enable</b><br><b>Example:</b> | Enables privileged EXEC mode. <ul style="list-style-type: none"> <li>• Enter your password if prompted.</li> </ul> |

|               | Command or Action                                                                                                                     | Purpose                                                                                 |
|---------------|---------------------------------------------------------------------------------------------------------------------------------------|-----------------------------------------------------------------------------------------|
|               | <code>Router&gt; enable</code>                                                                                                        |                                                                                         |
| <b>Step 2</b> | <b>configure terminal</b><br><b>Example:</b><br><code>Router# configure terminal</code>                                               | Enters global configuration mode.                                                       |
| <b>Step 3</b> | <b>interface gigabitethernet slot/subslot/port</b><br><b>Example:</b><br><code>Router(config)# interface gigabitethernet 3/0/0</code> | Enters interface cable configuration mode and specifies the Gigabit Ethernet interface. |
| <b>Step 4</b> | <b>mpls label protocol ldp</b><br><b>Example:</b><br><code>Router(config-if)# mpls label protocol ldp</code>                          | Enables MPLS LDP parameters on the specified Gigabit Ethernet interface.                |
| <b>Step 5</b> | <b>end</b><br><b>Example:</b><br><code>Router(config-if)# end</code>                                                                  | Exits interface cable configuration mode and enters privileged EXEC mode.               |

## Enabling the Cisco CMTS Support for MPLS Pseudowire for Cable L2VPN

You must enable the MPLS tunnel traffic on the network side of the interface to support configuration of MPLS pseudowires on a Cisco CMTS router.

### Procedure

|               | Command or Action                                                                       | Purpose                                                                                                            |
|---------------|-----------------------------------------------------------------------------------------|--------------------------------------------------------------------------------------------------------------------|
| <b>Step 1</b> | <b>enable</b><br><b>Example:</b><br><code>Router&gt; enable</code>                      | Enables privileged EXEC mode. <ul style="list-style-type: none"> <li>• Enter your password if prompted.</li> </ul> |
| <b>Step 2</b> | <b>configure terminal</b><br><b>Example:</b><br><code>Router# configure terminal</code> | Enters global configuration mode.                                                                                  |

|               | Command or Action                                                                                                                     | Purpose                                                          |
|---------------|---------------------------------------------------------------------------------------------------------------------------------------|------------------------------------------------------------------|
| <b>Step 3</b> | <b>cable l2-vpn-service xconnect nsi mpls</b><br><b>Example:</b><br><pre>Router(config)# cable l2-vpn-service xconnect nsi mpls</pre> | Enables the MPLS tunnel traffic, where:                          |
| <b>Step 4</b> | <b>exit</b><br><b>Example:</b><br><pre>Router(config)# exit</pre>                                                                     | Exits global configuration mode and enters privileged EXEC mode. |

## Customize MTU

You can extend the MTU to a maximum of 2000 B, which is the default value on a remote interface for DOCSIS 3.1 cable modem.

Use the following commands to customize and configure the MTU:

- To configure the MTU globally, run the following command:

```
router(config)#cable l2-vpn-service xconnect extended-mtu ?
<1500-2000> Customized MTU
<cr>
```

- To configure the MTU for each session, run the following command:

```
router(config-ethsrv)#xconnect 2.2.2.2 2000 encapsulation mpls extended-mtu ?
<1500-2000> in bytes without L2 overhead
```

## How to Provision MPLS Pseudowires

You can provision MPLS pseudowires in the following ways:



**Note** Before performing the static or dynamic provisioning of MPLS pseudowires, you must [enable MPLS](#) on a Cisco CMTS router.

## Dynamic Provisioning of MPLS Pseudowires

The dynamic provisioning method supports the following types of configurations:

- BSOD Specification-Based MPLS Pseudowire Provisioning
- Type-4 MPLS Pseudowire Provisioning Using the CM Configuration File
- Type-5 MPLS Pseudowire Provisioning Using the CM Configuration File

See the [Configuration Examples for Dynamic Provisioning of MPLS Pseudowires](#) for details about the dynamic provisioning method using the CM configuration file.



**Note** We recommend that you use the dynamic provisioning method instead of the static provisioning method for MPLS pseudowires.

## Static Provisioning Method for MPLS Pseudowires

The static provisioning method requires the MPLS pseudowire to be statically provisioned on the CMTS using the command line interface (CLI). This type of provisioning does not require the CM configuration file to use BSOD L2VPN-compliant TLVs. For details on how to statically provision MPLS pseudowires, see the *Static Provisioning of MPLS Pseudowires*.

## How to Configure L2VPN Pseudowire Redundancy

The L2VPN Pseudowire Redundancy feature enables you to switch to backup pseudowires when the primary pseudowire fails. The feature also allows the Cisco CMTS to resume operation on the primary pseudowire after it comes back up.

### Configuring the Backup Pseudowire

You can configure up to three backup pseudowires for a primary pseudowire. The priority of each backup pseudowire has to be unique.

A backup pseudowire is uniquely identified by a combination of IP address or hostname and VCID. Only the IP address or hostname and VCID can be configured for the backup peer, the remaining parameters are the same as the primary pseudowire.

Backup pseudowires can also be configured using the DOCSIS configuration files.

Perform the steps given below to configure a backup pseudowire.

#### Procedure

|        | Command or Action                                                                     | Purpose                                                                                                            |
|--------|---------------------------------------------------------------------------------------|--------------------------------------------------------------------------------------------------------------------|
| Step 1 | <b>enable</b><br><b>Example:</b><br><pre>Router&gt; enable</pre>                      | Enables privileged EXEC mode. <ul style="list-style-type: none"> <li>• Enter your password if prompted.</li> </ul> |
| Step 2 | <b>configure terminal</b><br><b>Example:</b><br><pre>Router# configure terminal</pre> | Enters global configuration mode.                                                                                  |

|               | Command or Action                                                                                                                                        | Purpose                                                                                                                                                                                           |
|---------------|----------------------------------------------------------------------------------------------------------------------------------------------------------|---------------------------------------------------------------------------------------------------------------------------------------------------------------------------------------------------|
| <b>Step 3</b> | <b>cable l2vpn mac-address</b><br><b>Example:</b><br><pre>Router(config)# cable l2vpn 0011.0011.0011</pre>                                               | Specifies L2VPN MAC address and enters L2VPN configuration mode.                                                                                                                                  |
| <b>Step 4</b> | <b>service instance id service-type</b><br><b>Example:</b><br><pre>Router(config-l2vpn)# service instance 1 ethernet</pre>                               | Specifies the service instance ID and enters Ethernet service configuration mode.                                                                                                                 |
| <b>Step 5</b> | <b>xconnect peer-ip-address vc-id encapsulation mpls</b><br><b>Example:</b><br><pre>Router(config-ethsrv)# xconnect 10.2.2.2 22 encapsulation mpls</pre> | Specifies the tunneling method to encapsulate the data in the MPLS pseudowire and enters xconnect configuration mode.                                                                             |
| <b>Step 6</b> | <b>backup peer peer-ip-address vc-id [priority value]</b><br><b>Example:</b><br><pre>Router(config-xconn)# backup peer 10.3.3.3 33 priority 2</pre>      | Specifies the backup pseudowire and its priority. The priority keyword is optional, if only one backup pseudowire is configured. When multiple backup pseudowires are configured, it is required. |
| <b>Step 7</b> | <b>end</b><br><b>Example:</b><br><pre>Router(config-xconn)# end</pre>                                                                                    | Exits xconnect configuration mode and enters Privileged EXEC mode.                                                                                                                                |

## Configuring Backup Delay

Perform the steps given below to configure the period the backup pseudowire should wait to take over after the primary pseudowire goes down. You can also specify how long the primary pseudowire should wait after it becomes active to take over from the backup pseudowire.

### Procedure

|               | Command or Action                                                | Purpose                                                                                                            |
|---------------|------------------------------------------------------------------|--------------------------------------------------------------------------------------------------------------------|
| <b>Step 1</b> | <b>enable</b><br><b>Example:</b><br><pre>Router&gt; enable</pre> | Enables privileged EXEC mode. <ul style="list-style-type: none"> <li>• Enter your password if prompted.</li> </ul> |

|        | Command or Action                                                                                                                                                                                                                                                                                                              | Purpose                                                                                                                                                                                                                                                                                                                                                                                                                                                                                                                                                                                                                                                                                                          |
|--------|--------------------------------------------------------------------------------------------------------------------------------------------------------------------------------------------------------------------------------------------------------------------------------------------------------------------------------|------------------------------------------------------------------------------------------------------------------------------------------------------------------------------------------------------------------------------------------------------------------------------------------------------------------------------------------------------------------------------------------------------------------------------------------------------------------------------------------------------------------------------------------------------------------------------------------------------------------------------------------------------------------------------------------------------------------|
| Step 2 | <p><b>configure terminal</b></p> <p><b>Example:</b></p> <pre>Router# configure terminal</pre>                                                                                                                                                                                                                                  | Enters global configuration mode.                                                                                                                                                                                                                                                                                                                                                                                                                                                                                                                                                                                                                                                                                |
| Step 3 | <p><b>cable l2vpn mac-address</b></p> <p><b>Example:</b></p> <pre>Router(config)# cable l2vpn 0011.0011.0011</pre>                                                                                                                                                                                                             | <p>Specifies the L2VPN MAC address and enters L2VPN configuration mode.</p> <ul style="list-style-type: none"> <li>• <i>mac-address</i>—MAC address of a CM.</li> </ul>                                                                                                                                                                                                                                                                                                                                                                                                                                                                                                                                          |
| Step 4 | <p><b>service instance id service-type</b></p> <p><b>Example:</b></p> <pre>Router(config-l2vpn)# service instance 1 ethernet</pre>                                                                                                                                                                                             | <p>Specifies the service instance ID and enters Ethernet service configuration mode.</p> <ul style="list-style-type: none"> <li>• <i>id</i>—Service instance ID.</li> <li>• <i>service-type</i>—Service type for the instance.</li> </ul>                                                                                                                                                                                                                                                                                                                                                                                                                                                                        |
| Step 5 | <p><b>xconnect peer-ip-address vc-id encapsulation mpls</b></p> <p><b>Example:</b></p> <pre>Router(config-ethsrv)# xconnect 10.2.2.2 22 encapsulation mpls</pre>                                                                                                                                                               | <p>Specifies the tunneling method to encapsulate the data in the MPLS pseudowire and enters xconnect configuration mode.</p> <ul style="list-style-type: none"> <li>• <i>peer-ip-address</i>—IP address of the remote PE router. The remote router ID can be any IP address, as long as it is reachable.</li> <li>• <i>vc-id</i>—32-bit identifier of the virtual circuit between the PE routers.</li> <li>• <b>encapsulation mpls</b>—Specifies MPLS as the tunneling method.</li> </ul>                                                                                                                                                                                                                        |
| Step 6 | <p>Do one of the following:</p> <ul style="list-style-type: none"> <li>• <b>backup delay enable-delay-period {disable-delay-period   never}</b></li> <li>•</li> </ul> <p><b>Example:</b></p> <pre>Router(config-xconn)# backup delay 10 10</pre> <p><b>Example:</b></p> <pre>Router(config-xconn)# backup delay 10 never</pre> | <p>Specifies the period to wait before enabling or disabling the backup pseudowire.</p> <ul style="list-style-type: none"> <li>• <i>enable-delay-period</i>—Number of seconds the backup pseudowire should wait to take over after the primary pseudowire goes down. The valid range is from 0 to 180 seconds, with a default value of 0.</li> <li>• <i>disable-delay-period</i>—Number of seconds the primary pseudowire should wait after it becomes active to take over from the backup pseudowire. The valid range is from 0 to 180 seconds, with a default value of 0.</li> <li>• <b>never</b>—Specifies the primary pseudowire should not be reactivated after moving to the backup pseudowire.</li> </ul> |
| Step 7 | <p><b>end</b></p> <p><b>Example:</b></p> <pre>Router(config-xconn)# end</pre>                                                                                                                                                                                                                                                  | Exits xconnect configuration mode and enters privileged EXEC mode.                                                                                                                                                                                                                                                                                                                                                                                                                                                                                                                                                                                                                                               |

## Performing Manual Switchover

Perform the steps given below to perform a manual switchover to the primary or backup pseudowire. The **xconnect backup force-switchover** command can also be used to forcefully switch to the backup pseudowire for planned outages of the primary remote peer.



**Note** A manual switchover can be made only to an available member in the redundancy group. If the pseudowire specified in the command is not available, the command will be rejected.

### Procedure

|               | Command or Action                                                                                                                                       | Purpose                                                                                                            |
|---------------|---------------------------------------------------------------------------------------------------------------------------------------------------------|--------------------------------------------------------------------------------------------------------------------|
| <b>Step 1</b> | <b>enable</b><br><b>Example:</b><br><pre>Router&gt; enable</pre>                                                                                        | Enables privileged EXEC mode. <ul style="list-style-type: none"> <li>• Enter your password if prompted.</li> </ul> |
| <b>Step 2</b> | <b>xconnect backup force-switchover peer 10.10.1.1 123</b><br><b>Example:</b><br><pre>Router# xconnect backup force-switchover peer 10.10.1.1 123</pre> | Specifies that the router should switch to the backup or to the primary pseudowire.                                |

## Troubleshooting Tips

The following commands help you troubleshoot an improper MPLS pseudowire configuration:

- **show ip interface brief**—Helps verify that the loopback interface with the IP address is present on each PE router.
- **show mpls l2transport vc**—Helps verify information about primary and backup pseudowires that have been enabled to route Layer 2 packets on a router.
- **show xconnect all**—Helps verify information about all xconnect attachment circuits and primary and backup pseudowires.
- **show cable l2-vpn xconnect mpls-vc-map**—Helps verify that the primary and backup pseudowires are configured properly.

## Configuration Examples for MPLS Pseudowire for Cable L2VPN

The following sections provide MPLS pseudowire configuration examples for the static and dynamic provisioning methods:



## Configuration Example for Static Provisioning of MPLS Pseudowires

The following example shows CLI-based provisioning of an MPLS pseudowire:

```
Router> enable
Router# configure terminal
Router(config)# cable l2vpn 0000.396e.6a68 customer2
Router(config-l2vpn)# service instance 2000 ethernet
Router(config-ethsrv)# xconnect 101.1.0.2 221 encapsulation mpls pw-type 4
Router(config-ethsrv)# cable set mpls-experimental 7
```

## Configuration Examples for Dynamic Provisioning of MPLS Pseudowires

The following sections provide MPLS pseudowire provisioning examples based on BSOD CableLabs specification, Type-4, and Type-5 TLVs using the CM configuration file:

### BSOD Specification-Based MPLS Pseudowire Provisioning: Example

The following example shows an MPLS pseudowire configuration based on BSOD CableLabs specification:

```
03 (Net Access Control) = 1
43 (Vendor Specific Options)
  S08 (Vendor ID) = ff ff ff
  S005 (L2VPN sub-type)
  =
    T01 (VPN Id) = 02 34 56 00 02 # VPNID=0234650002
    T02 (NSI) = 04 05 01 0a 4c 01 01# [04=mpls] [05=len][01=ipv4][IP=10.76.1.1]
    T05 (AGI) = 01 01 07 d1 # AGI = 0x010107d1
    T06 (SAII) = 00 00 07 d1 # SAII = TAI = VCID = 0x7d1 = 2001
    T07 (TAII) = 00 00 07 d1
18 (Maximum Number of CPE) = 16
24 (Upstream Service Flow Encodings)
  S01 (Service Flow Reference) = 1
  S06 (QoS Parameter Set Type) = 7
  S43 (Vendor Specific Options)
    T08 (Vendor ID) = ff ff ff
    T005 (L2VPN sub-type) =
      S01 (VPNID) = 02 34 56 00 02
      S08 (UserPrio) = 01

24 (Upstream Service Flow Encodings)
  S01 (Service Flow Reference) = 2
  S06 (QoS Parameter Set Type) = 7
  S43 (Vendor Specific Options)
    T08 (Vendor ID) = ff ff ff
    T005 (L2VPN sub-type) =
      S01 (VPNID) = 02 34 56 00 02
      S08 (UserPrio) = 04

24 (Upstream Service Flow Encodings)
  S01 (Service Flow Reference) = 3
  S06 (QoS Parameter Set Type) = 7
  S43 (Vendor Specific Options)
    T08 (Vendor ID) = ff ff ff
    T005 (L2VPN sub-type) =
      S01 (VPNID) = 02 34 56 00 02
      S08 (UserPrio) = 05

24 (Upstream Service Flow Encodings)
  S01 (Service Flow Reference) = 4
  S06 (QoS Parameter Set Type) = 7
```

```

S43 (Vendor Specific Options)
  T08 (Vendor ID) = ff ff ff
  T005 (L2VPN sub-type) =
    S01 (VPNID) = 02 34 56 00 02
    S08 (UserPrio) = 06
22 (Upstream Packet Classification Encoding Block)
  S01 (Classifier Reference) = 2
  S03 (Service Flow Reference) = 2
  S05 (Rule Priority) = 3
  S09 (IP Packet Encodings)
    T01 (IP Type of Srv Rng & Mask) = 00 20 ff
22 (Upstream Packet Classification Encoding Block)
  S01 (Classifier Reference) = 3
  S03 (Service Flow Reference) = 3
  S05 (Rule Priority) = 3
  S09 (IP Packet Encodings)
    T01 (IP Type of Srv Rng & Mask) = 21 40 ff
22 (Upstream Packet Classification Encoding Block)
  S01 (Classifier Reference) = 4
  S03 (Service Flow Reference) = 4
  S05 (Rule Priority) = 3
  S09 (IP Packet Encodings)
    T01 (IP Type of Srv Rng & Mask) = 41 ff ff
25 (Downstream Service Flow Encodings)
  S01 (Service Flow Reference) = 11
  S06 (QoS Parameter Set Type) = 7
25 (Downstream Service Flow Encodings)
  S01 (Service Flow Reference) = 12
  S06 (QoS Parameter Set Type) = 7
25 (Downstream Service Flow Encodings)
  S01 (Service Flow Reference) = 13
  S06 (QoS Parameter Set Type) = 7
25 (Downstream Service Flow Encodings)
  S01 (Service Flow Reference) = 14
  S06 (QoS Parameter Set Type) = 7
23 (Downstream Packet Classification Encoding Block)
  S01 (Classifier Reference) = 12
  S03 (Service Flow Reference) = 12
  S05 (Rule Priority) = 3
  S11 (IEEE 802.1P/Q Packet Classification Encodings)
    T01 (IEEE 802.1P UserPriority) = 00 02
  S43 (Vendor Specific Options)
    T08 (Vendor ID) = ff ff ff
    T005 (L2VPN sub-type)
      S01 (VPNID) = 02 34 56 00 02
23 (Downstream Packet Classification Encoding Block)
  S01 (Classifier Reference) = 13
  S03 (Service Flow Reference) = 13
  S05 (Rule Priority) = 3
  S11 (IEEE 802.1P/Q Packet Classification Encodings)
    T01 (IEEE 802.1P UserPriority) = 03 04
  S43 (Vendor Specific Options)
    T08 (Vendor ID) = ff ff ff
    T005 (L2VPN sub-type)
      S01 (VPNID) = 02 34 56 00 02
23 (Downstream Packet Classification Encoding Block)
  S01 (Classifier Reference) = 14
  S03 (Service Flow Reference) = 14
  S05 (Rule Priority) = 3
  S11 (IEEE 802.1P/Q Packet Classification Encodings)
    T01 (IEEE 802.1P UserPriority) = 05 06
  S43 (Vendor Specific Options)
    T08 (Vendor ID) = ff ff ff

```

```
T005 (L2VPN sub-type)
  S01 (VPNID) = 02 34 56 00 02
```

## Type-4 MPLS Pseudowire Provisioning Using the CM Configuration File: Example

The following example shows a CM configuration file-based provisioning of a Type-4 MPLS pseudowire:

```
03 (Net Access Control) = 1
43 (Vendor Specific Options)
  S08 (Vendor ID) = ff ff ff
  S005 (L2VPN Options) =
T001 (VPN ID) = 02 34 56 00 02 # VPN-ID = "0234560002"
T043 (Cisco Vendor Specific) = 2b 16
S008 (Vendor ID) = 00 00 0c # Vendor ID = "00 00 0C" - CISCO
S036 (MPLSPWTYPE) = 24 01 04 # MPLSPWTYPE= Type4 - Ethernet-vlan Type
S039 (MPLSPEERNAME) = 27 06 63 37 36 30 30 32 MPLSPEERNAME= "c76002" in ascii
S038 (MPLSVCID) = 26 04 00 00 07 d1 = 2001 VCID
43 (Vendor Specific Options)
  S08 (Vendor ID) = ff ff ff
  S005 (L2VPN Options) =
T001 (VPN ID) = 02 34 56 00 03 # VPN-ID = "0234560003"
T043 (Cisco Vendor Specific) = 2b 16
S008 (Vendor ID) = 00 00 0c Vendor ID = "00 00 0C" - CISCO
S036 (MPLSPWTYPE) = 24 01 04 MPLSPWTYPE= Type4 - Ethernet-vlan Type
S039 (MPLSPEERNAME) = 27 06 63 37 36 30 30 32 # MPLSPEERNAME= "c76002" in ascii
S038 (MPLSVCID) = 26 04 00 00 0b b9 # = 3001 VCID
43 (Vendor Specific Options)
  S08 (Vendor ID) = ff ff ff
  S005 (L2VPN Options) =
T001 (VPN ID) = 02 34 56 00 04 # VPN-ID = "0234560004"
T043 (Cisco Vendor Specific) = 2b 16
S008 (Vendor ID) = 00 00 0c # Vendor ID = "00 00 0C" - CISCO
S036 (MPLSPWTYPE) = 24 01 04 # MPLSPWTYPE= Type4 - Ethernet-vlan Type
S039 (MPLSPEERNAME) = 27 06 63 37 36 30 30 32 # MPLSPEERNAME= "c76002" in ascii
S038 (MPLSVCID) = 26 04 00 00 0f a1 # = 4001 VCID
18 (Maximum Number of CPE) = 16
24 (Upstream Service Flow Encodings)
  S01 (Service Flow Reference) = 1
  S06 (QoS Parameter Set Type) = 7
24 (Upstream Service Flow Encodings)
  S01 (Service Flow Reference) = 2
  S06 (QoS Parameter Set Type) = 7
  S43 (Vendor Specific Options)
    T08 (Vendor ID) = ff ff ff
    T001 (VPN ID) = 02 34 56 00 02
    T043 (Cisco Vendor Specific) = 2b 0A
S008 (Vendor ID) = 00 00 0c # Vendor ID = "00 00 0C" - CISCO

S034 (MPLS-EXP-SET) = 22 05 # MPLSEXP-INGRESS= 5
24 (Upstream Service Flow Encodings)
  S01 (Service Flow Reference) = 3
  S06 (QoS Parameter Set Type) = 7
  S43 (Vendor Specific Options)
    T08 (Vendor ID) = ff ff ff
    T001 (VPN ID) = 02 34 56 00 03
    T043 (Cisco Vendor Specific) = 2b 0A
S008 (Vendor ID) = 00 00 0c
# Vendor ID = "00 00 0C" - CISCO

S034 (MPLS-EXP-SET) = 22 06
# MPLSEXP-INGRESS= 6
```

## Type-4 MPLS Pseudowire Provisioning Using the CM Configuration File: Example

```

24 (Upstream Service Flow Encodings)
  S01 (Service Flow Reference) = 4
  S06 (QoS Parameter Set Type) = 7
  S43 (Vendor Specific Options)
    T08 (Vendor ID) = ff ff ff
    T001 (VPN ID) = 02 34 56 00 04
    T043 (Cisco Vendor Specific) = 2b 0A
S008 (Vendor ID) = 00 00 0c
# Vendor ID = "00 00 0C" - CISCO

S034 (MPLS-EXP-SET) = 22 04

# MPLSEXP-INGRESS= 4
22 (Upstream Packet Classification Encoding Block)
  S01 (Classifier Reference) = 2
  S03 (Service Flow Reference) = 2
  S11 (IEEE 802.1P/Q Packet Classification Encodings)
    T02 (IEEE 802.1Q VLAN ID) = 7d 00
  S05 (Rule Priority) = 2
22 (Upstream Packet Classification Encoding Block)
  S01 (Classifier Reference) = 3
  S03 (Service Flow Reference) = 3
  S11 (IEEE 802.1P/Q Packet Classification Encodings)
    T02 (IEEE 802.1Q VLAN ID) = bb 80
  S05 (Rule Priority) = 3
22 (Upstream Packet Classification Encoding Block)
  S01 (Classifier Reference) = 4
  S03 (Service Flow Reference) = 4
  S11 (IEEE 802.1P/Q Packet Classification Encodings)
    T02 (IEEE 802.1Q VLAN ID) = fa 00
  S05 (Rule Priority) = 4
25 (Downstream Service Flow Encodings)
  S01 (Service Flow Reference) = 11
  S06 (QoS Parameter Set Type) = 7
25 (Downstream Service Flow Encodings)
  S01 (Service Flow Reference) = 12
  S06 (QoS Parameter Set Type) = 7
25 (Downstream Service Flow Encodings)
  S01 (Service Flow Reference) = 13
  S06 (QoS Parameter Set Type) = 7
25 (Downstream Service Flow Encodings)
  S01 (Service Flow Reference) = 14
  S06 (QoS Parameter Set Type) = 7
23 (Downstream Packet Classification Encoding Block)
  S01 (Classifier Reference) = 12
  S03 (Service Flow Reference) = 12
  S11 (IEEE 802.1P/Q Packet Classification Encodings)
    T02 (IEEE 802.1Q VLAN ID) = 7d 00
  S43 (Vendor Specific Options)
    T08 (Vendor ID) = ff ff ff
    T001 (VPN ID) = 02 34 56 00 02
    T043 (Cisco Vendor Specific) = 2b 0B
S008 (Vendor ID) = 00 00 0c # Vendor ID = "00 00 0C" - CISCO
S035 (MPLS-EXP_RANGE) = 23 02 03 # MPLSEXP-EGRESS_RANGE= 2 - 3
  S05 (Rule Priority) = 2
23 (Downstream Packet Classification Encoding Block)
  S01 (Classifier Reference) = 13
  S03 (Service Flow Reference) = 13
  S11 (IEEE 802.1P/Q Packet Classification Encodings)
    T02 (IEEE 802.1Q VLAN ID) = bb 80
  S43 (Vendor Specific Options)
    T08 (Vendor ID) = ff ff ff
    T001 (VPN ID) = 02 34 56 00 03
    T043 (Cisco Vendor Specific) = 2b 0B

```

```

S008 (Vendor ID) = 00 00 0c # Vendor ID = "00 00 0C" - CISCO

S035 (MPLS-EXP-RANGE) = 23 04 05 # MPLSEXP-EGRESS_RANGE= 4 - 5
S05 (Rule Priority) = 3
23 (Downstream Packet Classification Encoding Block)
S01 (Classifier Reference) = 14
S03 (Service Flow Reference) = 14
S11 (IEEE 802.1P/Q Packet Classification Encodings)
T02 (IEEE 802.1Q VLAN ID) = fa 00
S43 (Vendor Specific Options)
T08 (Vendor ID) = ff ff ff
T001 (VPN ID) = 02 34 56 00 04
T043 (Cisco Vendor Specific) = 2b 0B
S008 (Vendor ID) = 00 00 0c # Vendor ID = "00 00 0C" - CISCO

S035 (MPLS-EXP-RANGE) = 23 00 01 # MPLSEXP-EGRESS_RANGE= 0 - 1
S05 (Rule Priority) = 4

```

## Type-5 MPLS Pseudowire Provisioning Using the CM Configuration File: Example

The following example shows a CM configuration file-based provisioning of a Type-5 MPLS pseudowire:

```

03 (Net Access Control) = 1
43 (Vendor Specific Options)
S08 (Vendor ID) = ff ff ff
S005 (L2VPN Options) =
T001 (VPN ID) = 02 34 56 00 02 # VPN-ID = "0234560002"
T043 (Cisco Vendor Specific) = 2b 16
S008 (Vendor ID) = 00 00 0c # Vendor ID = "00 00 0C" - CISCO
S036 (MPLSPWTYPE) = 24 01 05 # MPLSPWTYPE= Type5 - Ethernet-Port Type
S039 (MPLSPEERNAME) = 27 06 63 37 36 30 30 32 # MPLSPEERNAME= "c76002" in ascii
S038 (MPLSVCID) = 26 04 00 00 07 d1 # = 2001 VCID
45 (L2VPN CMIM) = 02 04 ff ff ff ff 01 01 01
18 (Maximum Number of CPE) = 16
24 (Upstream Service Flow Encodings)
S01 (Service Flow Reference) = 1
S06 (QoS Parameter Set Type) = 7
S43 (Vendor Specific Options)
T08 (Vendor ID) = ff ff ff
T001 (VPN ID) = 02 34 56 00 02 # VPN-ID = "0234560002"
T043 (Cisco Vendor Specific) = 2b 0A
S008 (Vendor ID) = 00 00 0c # Vendor ID = "00 00 0C" - CISCO
S034 (MPLS-EXP-SET) = 22 04 # MPLS-EXP-SET at INGRESS= 4
25 (Downstream Service Flow Encodings)
S01 (Service Flow Reference) = 12
S06 (QoS Parameter Set Type) = 7

```

## Configuration Examples for L2VPN Pseudowire Redundancy

The following sections provide L2VPN pseudowire redundancy configuration examples using the CM configuration file:

### Example: Configuring Backup Pseudowire Peer and VC ID

The following example shows how to provision a file-based backup peer router based on the CM configuration:

**Example: Configuring Backup Delay****PE Router 1**

```

cable l2vpn 0025.2e2d.7252
  service instance 1 ethernet
  encapsulation default
  xconnect 10.76.2.1 400 encapsulation mpls
  backup peer 10.76.2.1 600 priority 4

```

**PE Router2**

```

cable l2vpn 0011.0011.0011
  service instance 1 ethernet
  encapsulation default
  xconnect 10.2.2.2 22 encapsulation mpls
  backup peer 10.3.3.3 33 priority 2
  backup delay 10 10

```

**Example: Configuring Backup Delay**

The following example shows how to configure a backup delay to determine how much time should elapse before a secondary line status change after a primary line status has been changed.

```

cable l2vpn 0011.0011.0011
  service instance 1 ethernet
  encapsulation default
  xconnect 10.2.2.2 22 encapsulation mpls
  backup delay 10 10

```

**Example: L2VPN Backup MPLS Pseudowire Provisioning Using the CM Configuration File**

The following example shows how to provision an L2VPN Backup MPLS pseudowire based on the CM configuration file:

```

03 (Net Access Control)          = 1
18 (Maximum Number of CPE)      = 3
43 (Vendor Specific Options)
  S08 (Vendor ID)                = ff ff ff
  S005 (Unknown sub-type)        = 01 04 32 30 32 30 02 07 04 05 01 0a 4c 02 01 2b 15 26 04
00 00 00 14 28 10 01 05 01 0a 4c 02 01 03 04 00 00 07 08 04 01 05 28 0d 01 05 01 0a 4c 02
03 03 04 00 00 00 15 28 10 01 05 01 0a 4c 02 01 03 04 00 00 b1 8e 04 01 01 29 01 03 2a 01
01
24 (Upstream Service Flow Encodings)
  S01 (Service Flow Reference)    = 4
  S06 (QoS Parameter Set Type)    = 7
  S08 (Max Sustained Traffic Rate) = 2000000
  S09 (Max Traffic Burst)         = 3200
  S15 (Service Flow Sched Type)   = 2
  S43 (Vendor Specific Options)
    T08 (Vendor ID)               = ff ff ff
    T005 (Unknown sub-type)       = 01 04 32 30 32 30
25 (Downstream Service Flow Encodings)
  S01 (Service Flow Reference)    = 2
  S06 (QoS Parameter Set Type)    = 7
  S08 (Max Sustained Traffic Rate) = 3000000
  S09 (Max Traffic Burst)         = 250000
29 (Privacy Enable)              = 1

```

## Verifying the MPLS Pseudowire Configuration

Use the following **show** commands to verify the MPLS pseudowire configuration:

- **show mpls ldp discovery**
- **show cable l2-vpn xconnect**
- **show xconnect**
- **show mpls l2transport vc**

To verify the mapping between the MPLS pseudowire and virtual circuits for all cable modems, use the **show cable l2-vpn xconnect** command as shown in the following example:

```
Router# show cable l2-vpn xconnect mpls-vc-map
MAC Address      Peer IP Address VCID Type Prio CktID      Cable Intf  SID Customer Name/VPNID
0023.bee1.eb48   123.1.1.1      30  Prim* Bu254:4101 Cable3/0/0  3
38c8.5cac.4a62   123.1.1.1      20  Prim* Bu254:4100 Cable3/0/0  4  customer1
602a.d083.2e1c   123.1.1.1      60  Prim* Bu254:4102 Cable3/0/0  5
```

To verify the mapping between the MPLS pseudowire and virtual circuits for all cable modems when pseudowire redundancy is not configured, use the **show cable l2-vpn xconnect mpls-vc-map** command as shown in the following example:

```
Router# show cable l2-vpn xconnect mpls-vc-map
MAC Address      Peer IP Address VCID Type Prio CktID      Cable Intf  SID Customer Name/VPNID
0025.2e2d.7252   10.76.2.1      400 Prim* Bu254:400  Cable8/0/3  1
0014.f8c1.fd46   10.2.3.4        1000 Prim* Bu254:1000 Cable8/0/0  1  2020
0014.f8c1.fd46   10.76.2.1      1800 Prim* Bu254:1800 Cable8/0/0  1  2021
```

To verify the mapping between the MPLS pseudowire and virtual circuits for all cable modems when pseudowire redundancy is configured, use the **show cable l2-vpn xconnect mpls-vc-map** command as shown in the following example:

```
Router# show cable l2-vpn xconnect mpls-vc-map
MAC Address      Peer IP Address VCID Type Prio CktID      Cable Intf  SID Customer Name/VPNID
602a.d083.2e1c   123.1.1.1      60  Prim* Bu254:4102 Cable3/0/0  5
38c8.5cac.4a62   123.1.1.1      20  Prim* Bu254:4103 Cable3/0/0  4  000232303230
                  156.1.3.1      30  Bkup  3  Bu254:4103
                  123.1.1.1      50  Bkup  8  Bu254:4103
38c8.5cac.4a62   156.1.3.1      56  Prim* Bu254:4104 Cable3/0/0  4  000232303231
                  123.1.1.1      40  Bkup  1  Bu254:4104
```

To obtain the state of all virtual circuits associated with an MPLS pseudowire when pseudowire redundancy is not configured, use the **show cable l2-vpn xconnect mpls-vc-map state** command as shown in the following example:

```
Router# show cable l2-vpn xconnect mpls-vc-map state
MAC Address      Peer IP Address VCID Type Prio State Customer Name/VPNID State
602a.d083.2e1c   123.1.1.1      60  Prim* UP Customer Name/VPNID UP
38c8.5cac.4a62   123.1.1.1      20  Prim* UP 000232303230 UP
38c8.5cac.4a62   156.1.3.1      56  Prim* UP 000232303231 UP
```

To obtain the state of all virtual circuits associated with an MPLS pseudowire when pseudowire redundancy is configured, use the **show cable l2-vpn xconnect mpls-vc-map state** command as shown in the following example:

```
Router# show cable l2-vpn xconnect mpls-vc-map state
MAC Address      Peer IP Address VCID Type   Prio State Customer Name/VPNID State
602a.d083.2e1c   123.1.1.1      60  Prim*   UP     UP     000232303230 UP
38c8.5cac.4a62   123.1.1.1      20  Prim*   UP     UP     000232303230 STDBY
                 156.1.3.1      30  Bkup    3     UP     000232303230 STDBY
                 123.1.1.1      50  Bkup    8     DOWN  000232303230 STDBY
38c8.5cac.4a62   156.1.3.1      56  Prim*   UP     UP     000232303231 UP
                 123.1.1.1      40  Bkup    1     UP     000232303230 STDBY
```

When the local state of the modem is DOWN, the L2VPN is not configured on the WAN interface and the remote state of the L2VPN will be shown as OFF.

```
Router#show cable l2-vpn xconnect mpls-vc-map state
MAC Address      Peer IP Address VCID Type   Prio State Customer Name/VPNID State
602a.d083.2e1c   123.1.1.1      60  Prim*   OFF    DOWN  000232303230 DOWN
38c8.5cac.4a62   123.1.1.1      20  Prim*   UP     UP     000232303230 UP
38c8.5cac.4a62   156.1.3.1      56  Prim*   UP     UP     000232303231 UP
```

To verify information about the MPLS pseudowire mapping for a particular MAC address of a CM when pseudowire redundancy is configured, use the **show cable l2-vpn xconnect mpls-vc-map** command as shown in the following example:

```
Router# show cable l2-vpn xconnect mpls-vc-map 0025.2e2d.7252
MAC Address      Peer IP Address VCID Type   Prio CktID   Cable Intf SID Customer Name/VPNID
0025.2e2d.7252  10.76.2.1      400 Prim*   Bu254:400 Cable8/0/3 1
                 10.76.2.1      600 Bkup    4     Bu254:600
```

To verify the detailed information about the MPLS pseudowire mapping for a CM when pseudowire redundancy is configured, use the **show mpls l2-vpn xconnect mpls-vc-map verbose** command as shown in the following examples.

The following example shows the information for a modem for which pseudowires were configured using backup peer command:

```
Router# show cable l2-vpn xconnect mpls-vc-map 0025.2e2d.7252 verbose
MAC Address      : 0025.2e2d.7252
Customer Name    :
Prim Sid        : 1
Cable Interface  : Cable8/0/3
MPLS-EXP        : 0
PW TYPE         : Ethernet
Backup enable delay : 0 seconds
Backup disable delay : 0 seconds
Primary peer
Peer IP Address (Active) : 10.76.2.1
XConnect VCID      : 400
Circuit ID        : Bu254:400
Local State       : UP
Remote State      : UP
Backup peers
Peer IP Address    : 10.76.2.1
XConnect VCID     : 600
Circuit ID        : Bu254:600
Local State       : STDBY
Remote State      : UP
Priority           : 4
```



```

Total US pkts          : 0
Total US bytes        : 0
Total US pkts discards : 0
Total US bytes discards : 0
Total DS pkts         : 0
Total DS bytes        : 0
Total DS pkts discards : 0
Total DS bytes discards : 0

```

The following example shows the information for a modem for which pseudowires were created using the modem configuration file:

```

Router# show cable l2-vpn xconnect mpls-vc-map 0014.f8c1.fd46 verbose
MAC Address           : 0014.f8c1.fd46
Prim Sid              : 3
Cable Interface       : Cable8/0/0
L2VPNs provisioned   : 1
DUT Control/CMIM     : Disable/0x8000FFFF
VPN ID                : 2020
L2VPN SAID           : 12289
Upstream SFID Summary : 15
Downstream CFRID[SFID] Summary : Primary SF
CMIM                  : 0x60
PW TYPE               : Ethernet
MPLS-EXP              : 0
Backup enable delay   : 3 seconds
Backup disable delay  : 1 seconds
Primary peer
Peer IP Address (Active) : 10.2.3.4
XConnect VCID         : 1000
Circuit ID            : Bu254:1000
Local State           : UP
Remote State          : UP

Backup peers
Peer IP Address       : 10.2.3.4
XConnect VCID        : 21
Circuit ID           : Bu254:21
Local State          : STDBY
Remote State         : DOWN
Priority              : 2
Peer IP Address      : 10.76.2.1
XConnect VCID        : 1800
Circuit ID           : Bu254:1800
Local State          : STDBY
Remote State         : DOWN
Priority              : 5
Peer IP Address      : 10.76.2.1
XConnect VCID        : 45454
Circuit ID           : Bu254:45454
Local State          : STDBY
Remote State         : DOWN

```

To verify information about all attachment circuits and pseudowires for online modems, use the **show xconnect** command as shown in the following example:

```

Router# show xconnect all
Legend:  XC ST=Xconnect State  S1=Segment1 State  S2=Segment2 State
         UP=Up                DN=Down            AD=Admin Down     IA=Inactive
         SB=Standby           RV=Recovering     NH=No Hardware
XC ST  Segment 1                               S1 Segment 2                               S2

```

```

-----+-----+-----+-----+-----+-----+-----+-----+-----+-----+-----+-----+
UP      ac      Bu254:2001 (DOCSIS)           UP mpls 10.76.1.1:2001           UP
UP      ac      Bu254:2002 (DOCSIS)           UP mpls 10.76.1.1:2002           UP
UP      ac      Bu254:2004 (DOCSIS)           UP mpls 10.76.1.1:2004           UP
DN      ac      Bu254:22 (DOCSIS)             UP mpls 101.1.0.2:22            DN

```

To verify information about MPLS virtual circuits and static pseudowires that have been enabled to route Layer 2 packets on a Cisco CMTS router, use the **show mpls l2transport vc** command as shown in the following example:

```

Router# show mpls l2transport vc
-----+-----+-----+-----+-----+-----+-----+-----+-----+-----+-----+-----+
Local intf      Local circuit      Dest address      VC ID      Status
-----+-----+-----+-----+-----+-----+-----+-----+-----+-----+-----+-----+
Bu254           DOCSIS 2002        10.76.1.1         2002        UP
Bu254           DOCSIS 2003        10.76.1.1         2003        UP
Bu254           DOCSIS 2004        10.76.1.1         2004        DOWN
Bu254           DOCSIS 2017        10.76.1.1         2017        UP
Bu254           DOCSIS 2018        10.76.1.1         2018        UP
Bu254           DOCSIS 2019        10.76.1.1         2019        UP

```

## Additional References

### Standards

| Standard               | Title                                                                        |
|------------------------|------------------------------------------------------------------------------|
| CM-SP-L2VPN-I08-080522 | <i>Business Services over DOCSIS (BSOD) Layer 2 Virtual Private Networks</i> |
| L2VPN-N-10.0918-2      | <i>L2VPN MPLS Update</i>                                                     |

### MIBs

| MIB                                                                                                                              | MIBs Link                                                                                                                                                                                                                                                    |
|----------------------------------------------------------------------------------------------------------------------------------|--------------------------------------------------------------------------------------------------------------------------------------------------------------------------------------------------------------------------------------------------------------|
| <ul style="list-style-type: none"> <li>• DOCS-L2VPN-MIB</li> <li>• CISCO-IETF-PW-MIB</li> <li>• CISCO-CABLE-L2VPN-MIB</li> </ul> | To locate and download MIBs for selected platforms, Cisco IOS releases, and feature sets, use Cisco MIB Locator found at the following URL:<br><a href="http://tools.cisco.com/ITDIT/MIBS/servlet/index">http://tools.cisco.com/ITDIT/MIBS/servlet/index</a> |

### RFCs

| RFC      | Title                                                                                 |
|----------|---------------------------------------------------------------------------------------|
| RFC 3985 | <i>Pseudo Wire Emulation Edge-to-Edge (PWE3) Architecture</i>                         |
| RFC 4385 | <i>Pseudowire Emulation Edge-to-Edge (PWE3) Control Word for Use over an MPLS PSN</i> |
| RFC 4446 | <i>IANA Allocations for Pseudowire Edge-to-Edge Emulation (PWE3)</i>                  |
| RFC 4447 | <i>Pseudowire Setup and Maintenance Using the Label Distribution Protocol (LDP)</i>   |
| RFC 4448 | <i>Encapsulation Methods for Transport of Ethernet over MPLS Networks</i>             |

| RFC      | Title                                                                                                 |
|----------|-------------------------------------------------------------------------------------------------------|
| RFC 5085 | <i>Pseudowire Virtual Circuit Connectivity Verification (VCCV): A Control Channel for Pseudowires</i> |

### Technical Assistance

| Description                                                                                                                                                                                                                                                                                                                                                                           | Link                                                                                                              |
|---------------------------------------------------------------------------------------------------------------------------------------------------------------------------------------------------------------------------------------------------------------------------------------------------------------------------------------------------------------------------------------|-------------------------------------------------------------------------------------------------------------------|
| The Cisco Support and Documentation website provides online resources to download documentation, software, and tools. Use these resources to install and configure the software and to troubleshoot and resolve technical issues with Cisco products and technologies. Access to most tools on the Cisco Support and Documentation website requires a Cisco.com user ID and password. | <a href="http://www.cisco.com/cisco/web/support/index.html">http://www.cisco.com/cisco/web/support/index.html</a> |

## Feature Information for MPLS Pseudowire for Cable L2VPN

Use Cisco Feature Navigator to find information about the platform support and software image support. Cisco Feature Navigator enables you to determine which software images support a specific software release, feature set, or platform. To access Cisco Feature Navigator, go to the <https://cfng.cisco.com/> link. An account on the Cisco.com page is not required.



**Note** The following table lists the software release in which a given feature is introduced. Unless noted otherwise, subsequent releases of that software release train also support that feature.

**Table 201: Feature Information for MPLS Pseudowire for Cable L2VPN**

| Feature Name                    | Releases                    | Feature Information                                                                                               |
|---------------------------------|-----------------------------|-------------------------------------------------------------------------------------------------------------------|
| MPLS Pseudowire for Cable L2VPN | Cisco IOS XE Everest 16.6.1 | This feature was integrated into Cisco IOS XE Everest 16.6.1 on the Cisco cBR Series Converged Broadband Routers. |





## CHAPTER 54

# MPLS VPN Cable Enhancements

This feature module describes the Multiprotocol Label Switching Virtual Private Network (MPLS VPN) and cable interface bundling features. It explains how to create a VPN using MPLS protocol, cable interfaces, bundle interfaces and sub bundle interfaces. VPNs can be created in many ways using different protocols.

- [Finding Feature Information, on page 929](#)
- [Hardware Compatibility Matrix for the Cisco cBR Series Routers, on page 929](#)
- [Feature Overview, on page 931](#)
- [Prerequisites, on page 934](#)
- [Configuration Tasks, on page 935](#)
- [Configuration Examples, on page 940](#)
- [Additional References, on page 944](#)
- [Feature Information for MPLS VPN Cable Enhancements, on page 945](#)

## Finding Feature Information

Your software release may not support all the features that are documented in this module. For the latest feature information and caveats, see the release notes for your platform and software release. The Feature Information Table at the end of this document provides information about the documented features and lists the releases in which each feature is supported.

Use Cisco Feature Navigator to find information about platform support and Cisco software image support. To access Cisco Feature Navigator, go to <http://tools.cisco.com/ITDIT/CFN/>. An account on <http://www.cisco.com/> is not required.

## Hardware Compatibility Matrix for the Cisco cBR Series Routers



**Note** The hardware components that are introduced in a given Cisco IOS-XE Release are supported in all subsequent releases unless otherwise specified.

Table 202: Hardware Compatibility Matrix for the Cisco cBR Series Routers

| Cisco CMTS Platform                    | Processor Engine                                                                                                                                                                                  | Interface Cards                                                                                                                                                                                                                                                                                                                                                                                                                                                                                                                                                                                                                                                                                                                                                                                 |
|----------------------------------------|---------------------------------------------------------------------------------------------------------------------------------------------------------------------------------------------------|-------------------------------------------------------------------------------------------------------------------------------------------------------------------------------------------------------------------------------------------------------------------------------------------------------------------------------------------------------------------------------------------------------------------------------------------------------------------------------------------------------------------------------------------------------------------------------------------------------------------------------------------------------------------------------------------------------------------------------------------------------------------------------------------------|
| Cisco cBR-8 Converged Broadband Router | <p><b>Cisco IOS-XE Release 16.5.1 and Later Releases</b></p> <p>Cisco cBR-8 Supervisor:</p> <ul style="list-style-type: none"> <li>• PID—CBR-SUP-250G</li> <li>• PID—CBR-CCAP-SUP-160G</li> </ul> | <p><b>Cisco IOS-XE Release 16.5.1 and Later Releases</b></p> <p>Cisco cBR-8 CCAP Line Cards:</p> <ul style="list-style-type: none"> <li>• PID—CBR-LC-8D30-16U30</li> <li>• PID—CBR-LC-8D31-16U30</li> <li>• PID—CBR-RF-PIC</li> <li>• PID—CBR-RF-PROT-PIC</li> <li>• PID—CBR-CCAP-LC-40G</li> <li>• PID—CBR-CCAP-LC-40G-R</li> <li>• PID—CBR-CCAP-LC-G2-R</li> <li>• PID—CBR-SUP-8X10G-PIC</li> <li>• PID—CBR-2X100G-PIC</li> </ul> <p>Digital PICs:</p> <ul style="list-style-type: none"> <li>• PID—CBR-DPIC-8X10G</li> <li>• PID—CBR-DPIC-2X100G</li> </ul> <p>Cisco cBR-8 Downstream PHY Module:</p> <ul style="list-style-type: none"> <li>• PID—CBR-D31-DS-MOD</li> </ul> <p>Cisco cBR-8 Upstream PHY Modules:</p> <ul style="list-style-type: none"> <li>• PID—CBR-D31-US-MOD</li> </ul> |



**Note** Do not use DPICs (8X10G and 2x100G) to forward IP traffic, as it may cause buffer exhaustion, leading to line card reload.

The only allowed traffic on a DPIC interface is DEPI, UEPI, and GCP traffic from the Cisco cBR-8 router to Remote PHY devices. Other traffic such as DHCP, SSH, and UTSC should flow via another router, since DPICs cannot be used for normal routing.

# Feature Overview

Using MPLS VPN technology, service providers can create scalable and efficient private networks using a shared hybrid fiber coaxial (HFC) network and Internet protocol (IP) infrastructure.

The cable MPLS VPN network consists of:

- The Multiple Service Operator (MSO) or cable company that owns the physical infrastructure and builds VPNs for the Internet Service Providers (ISPs) to move traffic over the cable and IP backbone.
- ISPs that use the HFC network and IP infrastructure to supply Internet service to cable customers.

Each ISP moves traffic to and from a subscriber's PC, through the MSO's physical network infrastructure, to the ISP's network. MPLS VPNs, created in Layer 3, provide privacy and security by constraining the distribution of a VPN's routes only to the routers that belong to its network. Thus, each ISP's VPN is insulated from other ISPs that use the same MSO infrastructure.

An MPLS VPN assigns a unique VPN Routing/Forwarding (VRF) instance to each VPN. A VRF instance consists of an IP routing table, a derived forwarding table, a set of interfaces that use the forwarding table, and a set of rules and routing protocols that determine the contents of the forwarding table.

Each PE router maintains one or more VRF tables. It looks up a packet's IP destination address in the appropriate VRF table, only if the packet arrived directly through an interface associated with that table.

MPLS VPNs use a combination of BGP and IP address resolution to ensure security. See *Configuring Multiprotocol Label Switching*.

The table shows a cable MPLS VPN network. The routers in the network are:

- Provider (P) router—Routers in the core of the provider network. P routers run MPLS switching, and do not attach VPN labels (MPLS label in each route assigned by the PE router) to routed packets. VPN labels are used to direct data packets to the correct egress router.
- Provider Edge (PE) router—Router that adds the VPN label to incoming packets based on the interface or subinterface on which they are received. A PE router attaches directly to a CE router. In the MPLS-VPN approach, each Cisco CMTS router acts as a PE router.
- Customer (C) router—Router in the ISP or enterprise network.
- Customer Edge (CE) router—Edge router on the ISP's network that connects to the PE router on the MSO's network. A CE router must interface with a PE router.

The MPLS network has a unique VPN that exclusively manages the MSOs devices called the management VPN. It contains servers and devices that other VPNs can access. The management VPN connects the Cisco CMTS router to a PE router, which connects to management servers such as Cisco Network Registrar (CNR) and Time of Day (ToD) servers. A PE router connects to management servers and is a part of the management VPN. Regardless of the ISP they belong to, the management servers serve the Dynamic Host Configuration Protocol (DHCP), DNS (Domain Name System), and TOD requests coming from PCs or cable modems.



---

**Note** When configuring MPLS VPNs, you must configure the first subinterface created as a part of the management VPN.

---

Figure 29: MPLS VPN Network

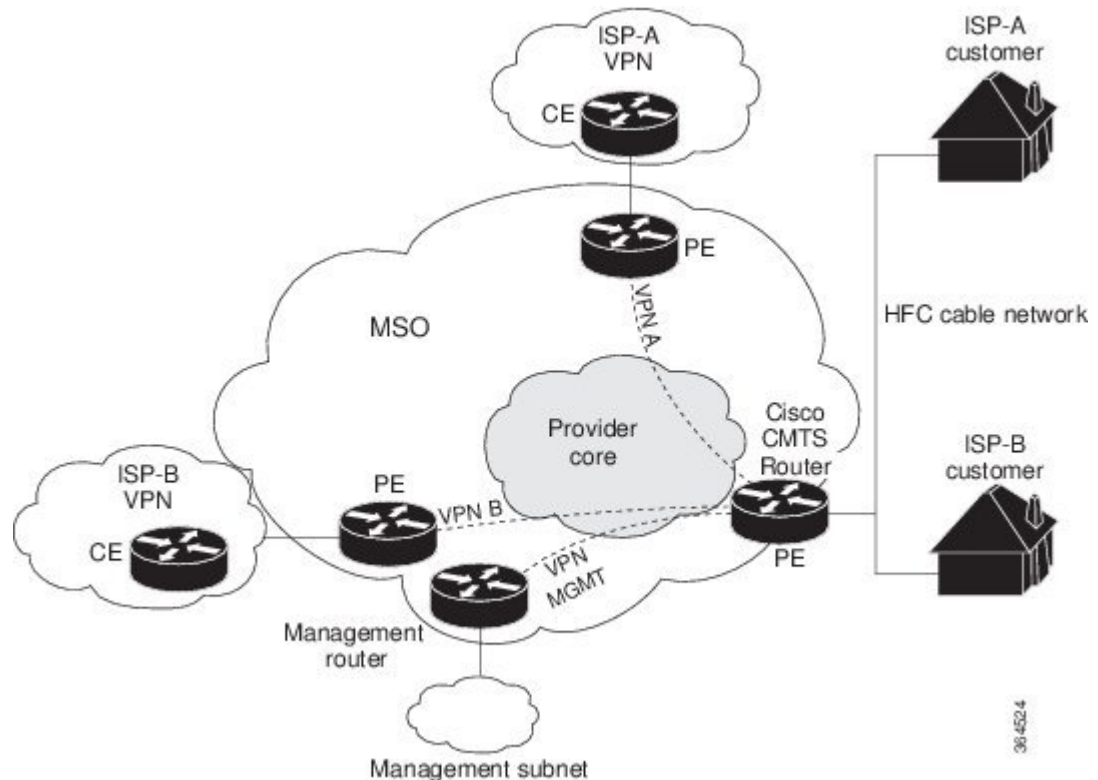

Cable VPN configuration involves an:

- MSO domain that requires a direct peering link to each enterprise network (ISP), provisioning servers for residential and commercial subscribers, and dynamic DNS for commercial users. The MSO manages cable interface IP addressing, Data-over-Cable Service Interface Specifications (DOCSIS) provisioning, CM hostnames, routing modifications, privilege levels, and usernames and passwords.
- ISP or enterprise domain that includes the DHCP server for subscriber or telecommuter host devices, enterprise gateway within the MSO address space, and static routes back to the telecommuter subnets.



**Note** Cisco recommends that the MSO assign all addresses to the end user devices and gateway interfaces. The MSO can also use split management to let the ISP configure tunnels and security.

In an MPLS VPN configuration, the MSO must configure the following:

- CMTS
- P routers
- PE routers
- CE routers
- One VPN per ISP DOCSIS servers for all cable modem customers. The MSO must attach DOCSIS servers to the management VPN, and make them visible.

The MSO must configure the Cisco CMTS routers that serve the ISP, and remote PE routers connecting to the ISP, as PE routers in the VPN.



The MSO must determine the primary IP address range for all cable modems.

The ISP must determine the secondary IP address range for subscriber PCs.

To reduce security breaches and differentiate DHCP requests from cable modems in VPNs or under specific ISP management, MSOs can use the **cable helper-address** command in Cisco IOS-XE software. The MSO can specify the host IP address to be accessible only in the ISP's VPN. This lets the ISP use its DHCP server to allocate IP addresses. Cable modem IP address must be accessible from the management VPN.

The MPLS VPN approach of creating VPNs for individual ISPs or customers requires subinterfaces to be configured on the virtual bundle interface. Each ISP requires one subinterface. The subinterfaces are tied to the VPN Routing/Forwarding (VRF) tables for their respective ISPs. The first subinterface must be created on the cable interface bound to the management VPN.

To route a reply from the CNR back to the cable modem, the PE router that connects to the CNR must import the routes of the ISP VPN into the management VPN. Similarly, to forward management requests (such as DHCP renewal to CNR) to the cable modems, the ISP VPN must export and import the appropriate management VPN routes.

You can group all of the cable interfaces on a Cisco CMTS router into a single bundle so that only one subnet is required for each router. When you group cable interfaces, no separate IP subnet or each individual cable interface is required. This grouping avoids the performance, memory, and security problems in using a bridging solution to manage subnets, especially for a large number of subscribers.

Subinterfaces allow traffic to be differentiated on a single physical interface, and assigned to multiple VPNs. You can configure multiple subinterfaces, and associate an MPLS VPN with each subinterface. You can split a single physical interface (the cable plant) into multiple subinterfaces, where each subinterface is associated with a specific VPN. Each ISP requires access on a physical interface and is given its own subinterface. Create a management subinterface to support cable modem initialization from an ISP.

Using each subinterface associated with a specific VPN (and therefore, ISP) subscribers connect to a logical subinterface, which reflects the ISP that provides their subscribed services. When properly configured, subscriber traffic enters the appropriate subinterface and VPN.

## Benefits

- MPLS VPNs give cable MSOs and ISPs a manageable way of supporting multiple access to a cable plant. Service providers can create scalable and efficient VPNs across the core of their networks. MPLS VPNs provide systems support scalability in cable transport infrastructure and management.
- Each ISP can support Internet access services from a subscriber's PC through an MSO's physical cable plant to their networks.
- MPLS VPNs allow MSOs to deliver value-added services through an ISP, and thus, deliver connectivity to a wider set of potential customers. MSOs can partner with ISPs to deliver multiple services from multiple ISPs and add value within the MSO's own network using VPN technology.
- Subscribers can select combinations of services from various service providers.
- The MPLS VPN cable features set build on CMTS DOCSIS 1.0 and DOCSIS 1.0 extensions to ensure services are reliably and optimally delivered over the cable plant. MPLS VPN provides systems support domain selection, authentication per subscriber, selection of QoS, policy-based routing, and ability to reach behind the cable modem to subscriber end devices for QoS and billing while preventing session spoofing.
- MPLS VPN technology ensures both secure access across the shared cable infrastructure and service integrity.

- Cable interface bundling eliminates the need for an IP subnet on each cable interface. Instead, an IP subnet is only required for each cable interface bundle. All cable interfaces in a Cisco CMTS router can be added to a single bundle.

## Restrictions

- Each subinterface on the CMTS requires an address range from the ISP and from the MSO. These two ranges must not overlap and must be extensible to support an increased number of subscribers for scalability.



---

**Note** This document does not address allocation and management of MSO and ISP IP addresses. See *Configuring Multiprotocol Label Switching* for this information.

---

- The **cable source-verify dhcp** command enables Dynamic Host Control Protocol (DHCP) Lease query protocol from the CMTS to DHCP server to verify IP addresses of upstream traffic, and prevent MSO customers from using unauthorized, spoofed, or stolen IP addresses.
- When using only MPLS VPNs, create subinterfaces on the virtual bundle, assign it an IP address, and provide VRF configuration for each ISP. When you create subinterfaces and configure only MPLS VPNs, the cable interface bundling feature is independent of the MPLS VPN.
- When using cable interface bundling:
  - Define a virtual bundle interface and associate any cable physical interface to the virtual bundle.
  - Specify all generic IP networking information (such as IP address, routing protocols, and switching modes) on the virtual bundle interface. Do not specify generic IP networking information on bundle subsidiary interfaces.
  - An interface that has a subinterface(s) defined over it is not allowed to be a part of the bundle.
  - Specify generic (not downstream or upstream related) cable interface configurations, such as source-verify or ARP handling, on the virtual bundle interface. Do not specify generic configuration on bundle subsidiary interfaces.
- Interface bundles can only be configured using the command line interface (including the CLI-based HTML configuration).

## Prerequisites

Before configuring IP-based VPNs, complete the following tasks:

- Ensure your network supports reliable broadband data transmission. Your plant must be swept, balanced, and certified based on National Television Standards Committee (NTSC) or appropriate international cable plant recommendations. Ensure your plant meets all DOCSIS or European Data-over-Cable Service Interface Specifications (EuroDOCSIS) downstream and upstream RF requirements.
- Ensure your Cisco router is installed following instructions in the Hardware Installation Guide and the Regulatory Compliance and Safety Information guide.
- Ensure your Cisco router is configured for basic operations.

- The chassis must contain at least one port adapter to provide backbone connectivity and one Cisco cable modem card to serve as the RF cable TV interface.

## Other Important Information

- Ensure all other required headend or distribution hub routing and network interface equipment is installed, configured, and operational based on the services to support. This includes all routers, servers (DHCP, TFTP, and ToD), network management systems, other configuration or billing systems and backbone, and other equipment to support VPN.
- Ensure DHCP and DOCSIS configuration files have been created and pushed to appropriate servers such that each cable modem, when initialized, can transmit a DHCP request, receive an IP address, obtain TFTP and ToD server addresses, and download a DOCSIS configuration file. Configure each subinterface to connect to the ISP's VPN.
- Ensure DOCSIS servers are visible on the management VPN.
- Be familiar with your channel plan to assign appropriate frequencies. Outline your strategies for setting up bundling or VPN solution sets if applicable to your headend or distribution hub. Obtain passwords, IP addresses, subnet masks, and device names as appropriate.
- Create subinterfaces off of a virtual bundle interface. Configure each subinterface to connect to the ISP network.

The MPLS VPN configuration steps assume the following:

- IP addressing has already been determined and there are assigned ranges in the MSO and ISP network for specific subinterfaces.
- The MSO is using CNR and has configured it (using the **cable helper-address** command) to serve appropriate IP addresses to cable modems based on the cable modem MAC address. The CMTS forwards DHCP requests to the CNR based on the **cable helper-address** settings. The CNR server determines the IP address to assign the cable modem using the client-classes feature, which let the CNR assign specific parameters to devices based on MAC addresses.
- ISP CE routers are configured (using the **cable helper-address** command) to appropriately route relevant IP address ranges into the VPN.
- P and PE routers are already running Cisco Express Forwarding (CEF).
- MPLS is configured on the outbound VPN using the **tag switching ip** command in interface configuration mode.

## Configuration Tasks

To configure MPLS VPNs, perform the following tasks:

### Creating VRFs for each VPN

To create VRFs for each VPN, perform the following steps beginning in the router configuration mode.



---

**Note** Since only the CMTS has logical subinterfaces, assignments of VRFs on the other PE devices will be to specific physical interfaces.

---

## Procedure

|                | Command or Action                                                                                      | Purpose                                                                                                                                                      |
|----------------|--------------------------------------------------------------------------------------------------------|--------------------------------------------------------------------------------------------------------------------------------------------------------------|
| <b>Step 1</b>  | Router(config)# <b>vrf definition</b> <i>mgmt-vpn</i>                                                  | Enters VRF configuration mode (config-vrf)# and maps a VRF table to the VPN (specified by <i>mgmt-vpn</i> ). The management VPN is the first VPN configured. |
| <b>Step 2</b>  | Router(config-vrf)# <b>rd</b> <i>mgmt-rd</i>                                                           | Creates a routing and forwarding table by assigning a route distinguisher to the management VPN.                                                             |
| <b>Step 3</b>  | Router(config-vrf)# <b>route-target</b> { <b>export</b>   <b>import</b>   <b>both</b> } <i>mgmt-rd</i> | Exports and/or imports all routes for the management VPNs route distinguisher. This determines which routes will be shared within VRFs.                      |
| <b>Step 4</b>  | Router(config-vrf)# <b>route-target import</b> <i>isp1-vpn-rd</i>                                      | Imports all routes for the VPNs ( <i>isp1-vpn</i> ) route distinguisher.                                                                                     |
| <b>Step 5</b>  | Router(config-vrf)# <b>route-target import</b> <i>isp2-vpn-rd</i>                                      | Imports all routes for the VPNs ( <i>isp2-vpn</i> ) route distinguisher.                                                                                     |
| <b>Step 6</b>  | Router(config-vrf)# <b>vrf definition</b> <i>isp1-vpn</i>                                              | Creates a routing and forwarding table by assigning a route distinguisher to <i>isp1-vpn</i> .                                                               |
| <b>Step 7</b>  | Router(config-vrf)# <b>rd</b> <i>mgmt-rd</i>                                                           | Creates a routing and forwarding table by assigning a route distinguisher (mgmt-rd) to the management VPN (mgmt-vpn).                                        |
| <b>Step 8</b>  | Router(config-vrf)# <b>route-target export</b> <i>isp1-vpn-rd</i>                                      | Exports all routes for the VPNs ( <i>isp1-vpn</i> ) route distinguisher.                                                                                     |
| <b>Step 9</b>  | Router(config-vrf)# <b>route-target import</b> <i>isp1-vpn-rd</i>                                      | Imports all routes for the VPNs ( <i>isp1-vpn</i> ) route distinguisher.                                                                                     |
| <b>Step 10</b> | Router(config-vrf)# <b>route-target import</b> <i>mgmt-vpn-rd</i>                                      | Exports all routes for the VPNs ( <i>mgmt-vpn</i> ) route distinguisher.                                                                                     |
| <b>Step 11</b> | Router(config-vrf)# <b>vrf definition</b> <i>isp2-vpn</i>                                              | Creates a routing and forwarding table by assigning a route distinguisher to <i>isp2-vpn</i> .                                                               |
| <b>Step 12</b> | Router(config-vrf)# <b>route-target export</b> <i>isp2-vpn-rd</i>                                      | Exports all routes for the VPNs ( <i>isp2-vpn</i> ) route distinguisher.                                                                                     |
| <b>Step 13</b> | Router(config-vrf)# <b>route-target import</b> <i>isp2-vpn-rd</i>                                      | Imports all routes for the VPNs ( <i>isp2-vpn</i> ) route distinguisher.                                                                                     |
| <b>Step 14</b> | Router(config-vrf)# <b>route-target import</b> <i>mgmt-vpn-rd</i>                                      | Imports all routes for the VPNs ( <i>mgmt-vpn</i> ) route distinguisher.                                                                                     |

## Defining Subinterfaces on a Virtual Bundle Interface and Assigning VRFs

To create a logical cable subinterface, perform the following steps beginning in the global configuration mode. Create one subinterface for each VPN (one per ISP). The first subinterface created must be configured as part of the management VPN (with the lowest subinterface number).

### Procedure

|                | Command or Action                                                        | Purpose                                                                                                                                 |
|----------------|--------------------------------------------------------------------------|-----------------------------------------------------------------------------------------------------------------------------------------|
| <b>Step 1</b>  | Router# <b>configure terminal</b>                                        | Enters configuration mode.                                                                                                              |
| <b>Step 2</b>  | Router(config)# <b>interface bundle n.x</b>                              | Enters virtual bundle interface configuration mode and defines the first (management) subinterface with the lowest subinterface number. |
| <b>Step 3</b>  | Router(config-subif)# <b>description string</b>                          | Identifies the subinterface as the management subinterface.                                                                             |
| <b>Step 4</b>  | Router(config-subif)# <b>vrf forwarding mgmt-vpn</b>                     | Assigns the subinterface to the management VPN (the MPLS VPN used by the MSO to supply service to customers).                           |
| <b>Step 5</b>  | Router(config-subif)# <b>ip address ipaddress mask</b>                   | Assigns the subinterface an IP address and a subnet mask.                                                                               |
| <b>Step 6</b>  | Router(config-subif)# <b>cable helper-address ip-address cable-modem</b> | Forwards DHCP requests from cable modems to the IP address listed.                                                                      |
| <b>Step 7</b>  | Router(config-subif)# <b>cable helper-address ip-address host</b>        | Forwards DHCP requests from hosts to the IP address listed.                                                                             |
| <b>Step 8</b>  | Router(config-if)# <b>interface bundle n.x</b>                           | Defines an additional subinterface for the ISP (such as isp1).                                                                          |
| <b>Step 9</b>  | Router(config-subif)# <b>description string</b>                          | Identifies the subinterface (such as subinterface for <i>isp1-vpn</i> ).                                                                |
| <b>Step 10</b> | Router(config-subif)# <b>vrf forwarding isp1-vpn</b>                     | Assigns the subinterface to <i>isp1-vpn</i> VPN.                                                                                        |
| <b>Step 11</b> | Router(config-subif)# <b>ip address ipaddress mask</b>                   | Assigns the subinterface an IP address and a subnet mask.                                                                               |
| <b>Step 12</b> | Router(config-subif)# <b>cable helper-address ip-address cable-modem</b> | Forwards DHCP requests from cable modems to the IP address listed.                                                                      |
| <b>Step 13</b> | Router(config-subif)# <b>cable helper-address ip-address host</b>        | Forwards DHCP requests from hosts to the IP address listed.                                                                             |
| <b>Step 14</b> | Router(config-if)# <b>interface bundle n.x</b>                           | Defines an additional subinterface for the ISP (such as isp2).                                                                          |
| <b>Step 15</b> | Router(config-subif)# <b>description string</b>                          | Identifies the subinterface (such as subinterface for <i>isp2-vpn</i> ).                                                                |
| <b>Step 16</b> | Router(config-subif)# <b>vrf forwarding isp2-vpn</b>                     | Assigns the subinterface to <i>isp2-vpn</i> VPN.                                                                                        |
| <b>Step 17</b> | Router(config-subif)# <b>ip address ipaddress mask</b>                   | Assigns the subinterface an IP address and a subnet mask.                                                                               |

|                | Command or Action                                                                         | Purpose                                                            |
|----------------|-------------------------------------------------------------------------------------------|--------------------------------------------------------------------|
| <b>Step 18</b> | Router(config-subif)# <b>cable helper-address</b> <i>ip-address</i><br><b>cable-modem</b> | Forwards DHCP requests from cable modems to the IP address listed. |
| <b>Step 19</b> | Router(config-subif)# <b>cable helper-address</b> <i>ip-address</i><br><b>host</b>        | Forwards DHCP requests from hosts to the IP address listed.        |
| <b>Step 20</b> | Router(config)# <b>exit</b>                                                               | Returns to configuration mode.                                     |

## Configuring Cable Interface Bundles

To assign a cable interface to a bundle, perform the following steps beginning in the interface configuration mode.

### Procedure

|               | Command or Action                                               | Purpose                                                                                                                                                                                                          |
|---------------|-----------------------------------------------------------------|------------------------------------------------------------------------------------------------------------------------------------------------------------------------------------------------------------------|
| <b>Step 1</b> | Router(config)# <b>interface cable</b> <i>slot/port</i>         | Enters the cable interface configuration mode.<br><br>IP addresses are not assigned to this interface. They are assigned to the logical subinterfaces created within this interface.                             |
| <b>Step 2</b> | Router(config-if)# <b>cable bundle</b> <i>bundle-number</i>     | Defines the interface as the bundle interface.                                                                                                                                                                   |
| <b>Step 3</b> | Router(config)# <b>interface cable</b> <i>slot/subslot/port</i> | Enters the cable interface configuration mode for another cable interface.<br><br>IP addresses are not assigned to this interface. They are assigned to the logical subinterfaces created within this interface. |
| <b>Step 4</b> | Router(config-if)# <b>cable bundle</b> <i>bundle-number</i>     | Adds the interface to the bundle specified by <i>bundle-number</i> .                                                                                                                                             |

## Configuring Subinterfaces and MPLS VPNs on a Virtual Bundle Interface

To configure subinterfaces on a virtual bundle interface and assign each subinterface a Layer 3 configuration:

Configure cable interface bundles.

Define subinterfaces on the virtual bundle interface and assign a Layer 3 configuration to each subinterface.

Create one subinterface for each customer VPN (one per ISP).

## Configuring MPLS in the P Routers in the Provider Core

To configure MPLS in the P routers in the provider core, perform the following steps.

**Procedure**

|               | <b>Command or Action</b>                                                               | <b>Purpose</b>                                                                                                                                                                                   |
|---------------|----------------------------------------------------------------------------------------|--------------------------------------------------------------------------------------------------------------------------------------------------------------------------------------------------|
| <b>Step 1</b> | Router# <b>configure terminal</b>                                                      | Enters configuration mode.                                                                                                                                                                       |
| <b>Step 2</b> | Router(config)# <b>ip cef</b>                                                          | Enables Cisco Express Forwarding (CEF) operation.<br>For information about CEF configuration and command syntax, see Cisco Express Forwarding Overview and Configuring Cisco Express Forwarding. |
| <b>Step 3</b> | Router(config)# <b>interface</b> <b>Tengigabitethernet</b><br><i>slot/subslot/port</i> | Enters GigabitEthernet interface configuration mode.                                                                                                                                             |
| <b>Step 4</b> | Router(config-if)# <b>ip address</b> <i>ip-address mask</i>                            | Defines the primary IP address range for the interface.                                                                                                                                          |
| <b>Step 5</b> | Router(config-if)# <b>mpls ip</b>                                                      | Enables the interface to be forwarded to an MPLS packet.                                                                                                                                         |
| <b>Step 6</b> | Router(config-if)# <b>exit</b>                                                         | Returns to global configuration mode.                                                                                                                                                            |
| <b>Step 7</b> | Router(config)# <b>mpls label-protocol ldp</b>                                         | Enables Label Distribution Protocol (LDP).<br>For information about LDP and MPLS, see Configuring Multiprotocol Label Switching.                                                                 |
| <b>Step 8</b> | Router(config)# <b>exit</b>                                                            | Returns to the configuration mode.                                                                                                                                                               |

## Verifying the MPLS VPN Configuration

Use the following commands to verify MPLS VPN operations on PE routers. For more MPLS VPN verification commands, see Configuring Multiprotocol Label Switching.

**Procedure**

|               | <b>Command or Action</b>                         | <b>Purpose</b>                                                             |
|---------------|--------------------------------------------------|----------------------------------------------------------------------------|
| <b>Step 1</b> | Router# <b>show ip vrf</b>                       | Displays the set of VRFs and interfaces.                                   |
| <b>Step 2</b> | Router# <b>show ip route vrf [vrf-name]</b>      | Displays the IP routing table for a VRF.                                   |
| <b>Step 3</b> | Router# <b>show ip protocols vrf [vrf-name]</b>  | Displays the routing protocol information for a VRF.                       |
| <b>Step 4</b> | Router# <b>show ip route vrf</b> <i>vrf-name</i> | Displays the Local and Remote CE devices that are in the PE routing table. |
| <b>Step 5</b> | Router# <b>show mpls forwarding-table</b>        | Displays entries for a VPN Routing/Forwarding instance.                    |

**What to do next**

For more verification instructions, see the [MPLS: Layer 3 VPNs Configuration Guide](#).

# Configuration Examples

This section provides the following configuration examples:

## VRF Definition Configuration

```
vrf definition Basketball
 rd 100:2
 route-target export 100:2
 route-target import 100:0
 route-target import 100:2
 !
 address-family ipv4
 exit-address-family
 !
 address-family ipv6
 exit-address-family
vrf definition Football
 rd 100:1
 route-target export 100:1
 route-target import 100:0
 route-target import 100:1
 !
 address-family ipv4
 exit-address-family
 !
 address-family ipv6
 exit-address-family
vrf definition MGMT
 rd 100:0
 route-target export 100:0
 route-target import 100:0
 !
 address-family ipv4
 exit-address-family
 !
 address-family ipv6
 exit-address-family
vrf definition Mgmt-intf
 !
 address-family ipv4
 exit-address-family
 !
 address-family ipv6
 exit-address-family
vrf definition Tennis
 rd 100:4
 route-target export 100:4
 route-target import 100:0
 route-target import 100:4
 !
 address-family ipv4
 exit-address-family
 !
 address-family ipv6
 exit-address-family
vrf definition Volleyball
 rd 100:3
 route-target export 100:3
```



```
route-target import 100:0
route-target import 100:3
!
address-family ipv4
exit-address-family
!
address-family ipv6
exit-address-family
```

## Cable Bundle SubInterface Configuration

```
interface Bundle255
  description Bundle Master Interface
  no ip address
  cable arp filter request-send 3 2
  cable arp filter reply-accept 3 2

interface Bundle255.1
  description Management Interface
  vrf forwarding MGMT
  ip address 112.51.0.1 255.255.0.0
  cable helper-address 20.11.0.162
  ipv6 address 2001:100:112:B001::1/64

interface Bundle255.2
  vrf forwarding Basketball
  ip address 112.54.0.1 255.255.0.0 secondary
  ip address 112.53.0.1 255.255.0.0
  cable helper-address 20.11.0.62
  cable helper-address 20.11.0.162
  ipv6 address 2001:100:112:B003::1/64
  ipv6 address 2001:100:112:B004::1/64

interface Bundle255.3
  vrf forwarding Football
  ip address 112.56.0.1 255.255.0.0 secondary
  ip address 112.55.0.1 255.255.0.0
  cable helper-address 20.11.0.62
  cable helper-address 20.11.0.162
  ipv6 address 2001:100:112:B005::1/64
  ipv6 address 2001:100:112:B006::1/64

interface Bundle255.4
  vrf forwarding Volleyball
  ip address 112.58.0.1 255.255.0.0 secondary
  ip address 112.57.0.1 255.255.0.0
  cable helper-address 20.11.0.62
  cable helper-address 20.11.0.162
  ipv6 address 2001:100:112:B007::1/64
  ipv6 address 2001:100:112:B008::1/64

interface Bundle255.5
  vrf forwarding Tennis
  ip address 112.61.0.1 255.255.0.0 secondary
  ip address 112.60.0.1 255.255.0.0 secondary
  ip address 112.59.0.1 255.255.0.0
  cable helper-address 20.11.0.162
  ipv6 address 2001:100:112:B009::1/64
  ipv6 address 2001:100:112:B00A::1/64
```

## PE WAN Interface Configuration

```

mpls label protocol ldp
mpls ldp nsr
mpls ldp graceful-restart

interface TenGigabitEthernet4/1/1
description WAN connection to cBR8
mtu 4470
ip address 100.6.120.5 255.255.255.252
ip router isis hub
ipv6 address 2001:100:6:120::5:1/112
ipv6 enable
mpls ip
mpls traffic-eng tunnels
cdp enable
isis circuit-type level-1
isis network point-to-point
isis csnp-interval 10
hold-queue 400 in
ip rsvp bandwidth 1000000
end

```

## PE BGP Configuration

```

router bgp 100
bgp router-id 100.120.120.120
bgp log-neighbor-changes
bgp graceful-restart restart-time 120
bgp graceful-restart stalepath-time 360
bgp graceful-restart
timers bgp 5 60
neighbor 100.100.4.4 remote-as 100
neighbor 100.100.4.4 ha-mode sso
neighbor 100.100.4.4 update-source Loopback0
neighbor 100.100.4.4 ha-mode graceful-restart
!
address-family ipv4
redistribute connected
redistribute static route-map static-route
redistribute rip
neighbor 100.100.4.4 activate
neighbor 100.100.4.4 send-community extended
neighbor 100.100.4.4 next-hop-self
neighbor 100.100.4.4 soft-reconfiguration inbound
maximum-paths ibgp 2
exit-address-family
!
address-family vpnv4
neighbor 100.100.4.4 activate
neighbor 100.100.4.4 send-community extended
exit-address-family
!
address-family ipv6
redistribute connected
redistribute rip CST include-connected
redistribute static metric 100 route-map static-route-v6
neighbor 100.100.4.4 activate
neighbor 100.100.4.4 send-community extended
neighbor 100.100.4.4 send-label

```

```
exit-address-family
!
address-family vpnv6
  neighbor 100.100.4.4 activate
  neighbor 100.100.4.4 send-community extended
exit-address-family
!
address-family ipv4 vrf Basketball
  redistribute connected
exit-address-family
!
address-family ipv6 vrf Basketball
  redistribute connected
  redistribute static metric 100
exit-address-family
!
address-family ipv4 vrf Football
  redistribute connected
exit-address-family
!
address-family ipv6 vrf Football
  redistribute connected
  redistribute static metric 100
exit-address-family
!
address-family ipv4 vrf MGMT
  redistribute connected
exit-address-family
!
address-family ipv6 vrf MGMT
  redistribute connected
exit-address-family
!
address-family ipv4 vrf Tennis
  redistribute connected
  redistribute static route-map static-route
  redistribute rip
exit-address-family
!
address-family ipv6 vrf Tennis
  redistribute connected
  redistribute rip CST include-connected
  redistribute static metric 100 route-map static-route-v6
exit-address-family
!
address-family ipv4 vrf Volleyball
  redistribute connected
  redistribute static route-map static-route
  redistribute rip
exit-address-family
!
address-family ipv6 vrf Volleyball
  redistribute connected
  redistribute rip CST include-connected
  redistribute static metric 100 route-map static-route-v6
exit-address-family
```

# Additional References

## Standards

| Standard   | Title             |
|------------|-------------------|
| DOCSIS 1.0 | <i>DOCSIS 1.0</i> |

## MIBs

| MIB                        | MIBs Link                                                                                                                                                                                                                                                        |
|----------------------------|------------------------------------------------------------------------------------------------------------------------------------------------------------------------------------------------------------------------------------------------------------------|
| CISCO-DOCS-REMOTE-QUERY.my | To locate and download MIBs for selected platforms, Cisco IOS releases, and feature sets, use Cisco MIB Locator found at the following URL:<br><br><a href="http://tools.cisco.com/ITDIT/MIBS/servlet/index">http://tools.cisco.com/ITDIT/MIBS/servlet/index</a> |

## RFCs

| RFC      | Title                                                      |
|----------|------------------------------------------------------------|
| RFC 1163 | A Border Gateway Protocol                                  |
| RFC 1164 | Application of the Border Gateway Protocol in the Internet |
| RFC 2283 | Multiprotocol Extensions for BGP-4                         |
| RFC 2547 | BGP/MPLS VPNs                                              |
| RFC 2233 | DOCSIS OSSI Objects Support                                |
| RFC 2669 | Cable Device MIB                                           |

**Technical Assistance**

| Description                                                                                                                                                                                                                                                                                                                                                                           | Link                                                                                                              |
|---------------------------------------------------------------------------------------------------------------------------------------------------------------------------------------------------------------------------------------------------------------------------------------------------------------------------------------------------------------------------------------|-------------------------------------------------------------------------------------------------------------------|
| The Cisco Support and Documentation website provides online resources to download documentation, software, and tools. Use these resources to install and configure the software and to troubleshoot and resolve technical issues with Cisco products and technologies. Access to most tools on the Cisco Support and Documentation website requires a Cisco.com user ID and password. | <a href="http://www.cisco.com/cisco/web/support/index.html">http://www.cisco.com/cisco/web/support/index.html</a> |

## Feature Information for MPLS VPN Cable Enhancements

Use Cisco Feature Navigator to find information about the platform support and software image support. Cisco Feature Navigator enables you to determine which software images support a specific software release, feature set, or platform. To access Cisco Feature Navigator, go to the <https://cfng.cisco.com/> link. An account on the Cisco.com page is not required.



**Note** The following table lists the software release in which a given feature is introduced. Unless noted otherwise, subsequent releases of that software release train also support that feature.

**Table 203: Feature Information for MPLS VPN Cable Enhancements**

| Feature Name                                                     | Releases                    | Feature Information                                                                                              |
|------------------------------------------------------------------|-----------------------------|------------------------------------------------------------------------------------------------------------------|
| Multiprotocol Label Switching Virtual Private Network (MPLS VPN) | Cisco IOS XE Everest 16.6.1 | This feature was integrated into Cisco IOS XE Everest 16.6.1 on the Cisco cBR Series Converged Broadband Router. |





## CHAPTER 55

# Multicast VPN and DOCSIS 3.0 Multicast QoS Support

---

The CMTS enhanced multicast new features are consistent with DOCSIS 3.0 specifications and include:

- Enhanced multicast echo in which the Layer 3 multicast switching path uses a Cisco Packet Processor (CPP) parallel express forwarding multicast routing table.
- Enhanced multicast quality of service (MQoS) framework that specifies a group configuration (GC) to define a session range of multicast addresses and rule priorities and its associated multicast VPN (MVPN).
- Intelligent multicast admission control to include multicast service flows.
- Enhanced multicast VPN feature to configure and support multicast traffic in a multiprotocol label switching (MPLS)-VPN environment.
- [Finding Feature Information, on page 947](#)
- [Hardware Compatibility Matrix for the Cisco cBR Series Routers, on page 948](#)
- [Restrictions for the Multicast VPN and DOCSIS 3.0 Multicast QoS Support, on page 949](#)
- [Information About the Multicast VPN and DOCSIS 3.0 Multicast QoS Support, on page 949](#)
- [How to Configure the Multicast VPN and DOCSIS 3.0 Multicast QoS Support, on page 951](#)
- [Configuration Examples for the Multicast VPN and DOCSIS 3.0 Multicast QoS Support, on page 955](#)
- [Additional References, on page 955](#)
- [Feature Information for Multicast VPN and DOCSIS3.0 Multicast QoS Support, on page 957](#)

## Finding Feature Information

Your software release may not support all the features that are documented in this module. For the latest feature information and caveats, see the release notes for your platform and software release. The Feature Information Table at the end of this document provides information about the documented features and lists the releases in which each feature is supported.

Use Cisco Feature Navigator to find information about platform support and Cisco software image support. To access Cisco Feature Navigator, go to <http://tools.cisco.com/ITDIT/CFN/>. An account on <http://www.cisco.com/> is not required.

# Hardware Compatibility Matrix for the Cisco cBR Series Routers



**Note** The hardware components that are introduced in a given Cisco IOS-XE Release are supported in all subsequent releases unless otherwise specified.

**Table 204: Hardware Compatibility Matrix for the Cisco cBR Series Routers**

| Cisco CMTS Platform                    | Processor Engine                                                                                                                                                                                  | Interface Cards                                                                                                                                                                                                                                                                                                                                                                                                                                                                                                                                                                                                                                                                                                                                                                                 |
|----------------------------------------|---------------------------------------------------------------------------------------------------------------------------------------------------------------------------------------------------|-------------------------------------------------------------------------------------------------------------------------------------------------------------------------------------------------------------------------------------------------------------------------------------------------------------------------------------------------------------------------------------------------------------------------------------------------------------------------------------------------------------------------------------------------------------------------------------------------------------------------------------------------------------------------------------------------------------------------------------------------------------------------------------------------|
| Cisco cBR-8 Converged Broadband Router | <p><b>Cisco IOS-XE Release 16.5.1 and Later Releases</b></p> <p>Cisco cBR-8 Supervisor:</p> <ul style="list-style-type: none"> <li>• PID—CBR-SUP-250G</li> <li>• PID—CBR-CCAP-SUP-160G</li> </ul> | <p><b>Cisco IOS-XE Release 16.5.1 and Later Releases</b></p> <p>Cisco cBR-8 CCAP Line Cards:</p> <ul style="list-style-type: none"> <li>• PID—CBR-LC-8D30-16U30</li> <li>• PID—CBR-LC-8D31-16U30</li> <li>• PID—CBR-RF-PIC</li> <li>• PID—CBR-RF-PROT-PIC</li> <li>• PID—CBR-CCAP-LC-40G</li> <li>• PID—CBR-CCAP-LC-40G-R</li> <li>• PID—CBR-CCAP-LC-G2-R</li> <li>• PID—CBR-SUP-8X10G-PIC</li> <li>• PID—CBR-2X100G-PIC</li> </ul> <p>Digital PICs:</p> <ul style="list-style-type: none"> <li>• PID—CBR-DPIC-8X10G</li> <li>• PID—CBR-DPIC-2X100G</li> </ul> <p>Cisco cBR-8 Downstream PHY Module:</p> <ul style="list-style-type: none"> <li>• PID—CBR-D31-DS-MOD</li> </ul> <p>Cisco cBR-8 Upstream PHY Modules:</p> <ul style="list-style-type: none"> <li>• PID—CBR-D31-US-MOD</li> </ul> |





---

**Note** Do not use DPICs (8X10G and 2x100G) to forward IP traffic, as it may cause buffer exhaustion, leading to line card reload.

The only allowed traffic on a DPIC interface is DEPI, UEPI, and GCP traffic from the Cisco cBR-8 router to Remote PHY devices. Other traffic such as DHCP, SSH, and UTSC should flow via another router, since DPICs cannot be used for normal routing.

---

## Restrictions for the Multicast VPN and DOCSIS 3.0 Multicast QoS Support

The type of service (ToS) parameter is not recognized by the Cisco cBR series routers.

To avail 40000 multicast sessions, a minimum of one bundle should be present for each LC.

## Information About the Multicast VPN and DOCSIS 3.0 Multicast QoS Support

IP multicast—transmission of the same information to multiple cable network recipients—improves bandwidth efficiency and allows service providers to offer differentiated quality of service for different types of traffic. Enhanced multicast introduces multicast improvements as mandated by the introduction of DOCSIS 3.0 specifications.



---

**Note** DOCSIS 3.0 standards retain backwards compatibility with the DOCSIS 2.0 multicast mode of operation.

---

The Cisco cBR routers support 40000 DSG multicast sessions per chassis.

The following are the benefits of CMTS enhanced multicast are:

## Enhanced Quality of Service

In the new multicast QoS (MQoS) framework, you can specify a group configuration (GC) that defines a session range of multicast addresses and rule priorities and its associated multicast VPN (MVPN). For every GC, there is attached a group QoS configuration (GQC) and a group encryption rule.

Based on the session range, rule priority, and MVPN, a multicast service flow is admitted into a GC and the associated GQC and group encryption rule are applied to the flow. In MQoS implementation, the source address of the multicast session is not checked because the current implementation for cable-specific multicast supports IGMP Version 2 but not IGMP Version 3. The downstream service flow, service identifier (SID), and MAC-rewrite string are created at the time of a new IGMP join (or static multicast group CLI on the interface) and MQoS is applied to the new multicast group join.

The benefits of enhanced QoS are the following:

- Group classifiers can be applied at cable interface level and also at bundle interface level.

- Group service flow (GSF) definition is based on service class names. The GSF is similar to individual service flows and commonly includes the minimum rate and maximum rate parameters for the service class. GSF is shared by all cable modems on a particular downstream channel set (DCS) that is matched to the same group classifier rule (GCR). A default service flow is used for multicast flows that do not match to any GCR. A GSF is always in the active state.
- CMTS replicates multicast packets and then classifies them.
- Single-stage replication and two-stage replication are supported.
- Enhanced QoS is compatible and integrated with DOCSIS Set-Top Gateway (DSG).

## Intelligent Multicast Admission Control

Admission control allows you to categorize service flows into buckets. Examples of categories are the service class name used to create the service flow, service flow priority, or the service flow type such as unsolicited grant service (UGS). Bandwidth limits for each bucket can also be defined. For example, you can define bucket 1 for high priority packet cable service flows and specify that bucket 1 is allowed a minimum of 30 percent and a maximum of 50 percent of the link bandwidth.

Intelligent multicast admission control includes additional features such as the inclusion of multicast service flows using the GSF concept. GSFs are created based on the rules as defined in the GQC table. The rules link the multicast streams to a GSF through the session range. The service class name in the rule defines the QoS for that GSF. Additionally, another attribute is added to the rules and the group configuration table to specify the application type to which each GSF belongs. In this way, the QoS associated with each GSF is independent of the bucket category for the GSF.

The benefits of intelligent multicast admission control are the following:

- There is explicit acknowledgment of the establishment of each multicast session.
- Admission control does not consume additional bandwidth for multicast flows once the first flow is established.
- Service flows are cleaned up as the multicast session is torn down.

## Multicast Session Limit Support

In a multicast video environment, you can limit the number of multicast sessions admitted onto a particular service flow. The multicast session limit feature—which adds functionality on top of the multicast QoS infrastructure—enables you to specify the number of multicast sessions to be admitted on a particular service flow. If the current number of sessions has reached the defined limit, new sessions will be forwarded but they will make use of the default multicast service flow until a session ends to free up a slot for new sessions.

## Multicast Virtual Private Network

The new multicast VPN (MVPN) feature allows you to configure and support multicast traffic in a multiprotocol label switching (MPLS)-VPN environment. This feature supports routing and forwarding of multicast packets for each individual VPN virtual routing and forwarding (VRF) instance, and also provides a mechanism to transport VPN multicast packets across the service provider backbone.

MVPN allows you to connect multiple remote sites or devices over either a Layer 3 or Layer 2 VPN. A Layer 3 VPN enables the routing of traffic inside the VPN. A Layer 2 VPN provides a bridging transport mechanism for traffic between remote sites belonging to a customer. To support multicast over Layer 3 VPNs, each VPN receives a separate multicast domain with an associated MVPN routing and forwarding (mVRF) table maintained by the provider edge (PE) router. In a cable environment, the PE router is a routing CMTS. The

provider network builds a default multicast distribution tree (default-MDT) for each VPN between all the associated mVRF-enabled PE routers. This tree is used to distribute multicast traffic to all PE routers.

To enable maximum security and data privacy in a VPN environment, the CMTS distinguishes between multicast sessions on the same downstream interface that belong to different VPNs. To differentiate multicast traffic between different VPNs, the CMTS implements a per-VRF subinterface multicast security association identifier (MSAID) allocation feature that is BPI+ enabled. The MSAID is allocated for each cable bundle group for each subinterface. A multicast group has a specific MSAID for each VRF instance.

## How to Configure the Multicast VPN and DOCSIS 3.0 Multicast QoS Support

This section contains the following procedures:

### Configuring a QoS Profile for a Multicast Group

To configure a QoS profile that can be applied to a QoS group configuration, use the **cable multicast group-qos** command. You must configure a QoS profile before you can add a QoS profile to a QoS multicast group.

#### Procedure

|        | Command or Action                                                                                                                                                                                                        | Purpose                                                                                                                                                                                                                                                                                                                                                        |
|--------|--------------------------------------------------------------------------------------------------------------------------------------------------------------------------------------------------------------------------|----------------------------------------------------------------------------------------------------------------------------------------------------------------------------------------------------------------------------------------------------------------------------------------------------------------------------------------------------------------|
| Step 1 | <b>enable</b><br><b>Example:</b><br><pre>Router&gt; enable</pre>                                                                                                                                                         | Enables privileged EXEC mode. <ul style="list-style-type: none"> <li>• Enter your password if prompted.</li> </ul>                                                                                                                                                                                                                                             |
| Step 2 | <b>configure terminal</b><br><b>Example:</b><br><pre>Router# configure terminal</pre>                                                                                                                                    | Enters global configuration mode.                                                                                                                                                                                                                                                                                                                              |
| Step 3 | <b>cable multicast group-qos number scn service-class-name control { single   aggregate [limit max-sessions]}</b><br><b>Example:</b><br><pre>Router(config)#: cable multicast group-qos 2 scn name1 control single</pre> | Configures a QoS profile that can be applied to a multicast QoS group. <p><b>Note</b> If a number is not specified, a default QoS profile is applied. The default group qos configuration creates a default multicast service flow for each cable interface that is used when a multicast session does not match any classifiers of a GC on the interface.</p> |

### Configuring a Multicast QoS Group

You can specify a group configuration (GC) that defines a session range of multicast addresses and rule priorities and its associated multicast VPN (MVPN). For every GC, there is attached a group QoS configuration and a group encryption rule.

## Procedure

|               | Command or Action                                                                                                                                                                                                                                                         | Purpose                                                                                                                                                                                                                                                                                                                                                                                                                                                                |
|---------------|---------------------------------------------------------------------------------------------------------------------------------------------------------------------------------------------------------------------------------------------------------------------------|------------------------------------------------------------------------------------------------------------------------------------------------------------------------------------------------------------------------------------------------------------------------------------------------------------------------------------------------------------------------------------------------------------------------------------------------------------------------|
| <b>Step 1</b> | <b>enable</b><br><b>Example:</b><br><pre>Router&gt; enable</pre>                                                                                                                                                                                                          | Enables privileged EXEC mode. <ul style="list-style-type: none"> <li>• Enter your password if prompted.</li> </ul>                                                                                                                                                                                                                                                                                                                                                     |
| <b>Step 2</b> | <b>configureterminal</b><br><b>Example:</b><br><pre>Router# configure terminal</pre>                                                                                                                                                                                      | Enters global configuration mode.                                                                                                                                                                                                                                                                                                                                                                                                                                      |
| <b>Step 3</b> | <b>cable multicast group-qos</b> <i>number scn service-class-name</i><br><b>control</b> { <b>single</b>   <b>aggregate</b> [ <i>limit max-sessions</i> ]}<br><b>Example:</b><br><pre>Router(config-mqos) # cable multicast group-qos 5<br/>scn name1 control single</pre> | (Optional) Configures a QoS profile that can be applied to a multicast QoS group.<br><br><b>Note</b> If a number is not specified, a default QoS profile is applied. The default group qos configuration creates a default multicast service flow for each cable interface that is used when a multicast session does not match any classifiers of a GC on the interface.                                                                                              |
| <b>Step 4</b> | <b>cable multicast qos group</b> <i>id priority value</i> [ <b>global</b> ]<br><b>Example:</b><br><pre>Router(config) # cable multicast qos group 2<br/>priority 6</pre>                                                                                                  | Configures a multicast QoS group and enters multicast QoS configuration mode.                                                                                                                                                                                                                                                                                                                                                                                          |
| <b>Step 5</b> | <b>session-range</b> <i>ip-address ip-mask</i><br><b>Example:</b><br><pre>Router(config-mqos) # session-range 224.10.10.10<br/>255.255.255.224</pre>                                                                                                                      | Specifies the session range IP address and IP mask of the multicast QoS group. You can configure multiple session ranges.                                                                                                                                                                                                                                                                                                                                              |
| <b>Step 6</b> | <b>tos</b> <i>low-byte high-byte mask</i><br><b>Example:</b><br><pre>Router(config-mqos) # tos 1 6 15</pre>                                                                                                                                                               | (Optional) Specifies the minimum type of service (ToS) data bytes, maximum ToS data bytes, and mask for a multicast QoS group.                                                                                                                                                                                                                                                                                                                                         |
| <b>Step 7</b> | <b>vrfname</b><br><b>Example:</b><br><pre>Router(config-mqos) # vrf name1</pre>                                                                                                                                                                                           | (Optional) Specifies the name for the virtual routing and forwarding (VRF) instance.<br><br><b>Note</b> If a multicast QoS (MQoS) group is not defined for this VRF, you will see an error message. You must either define a specific MQoS group for each VRF, or define a default MQoS group that can be assigned in those situations where no matching MQoS group is found. See the <a href="#">Configuring a Default Multicast QoS Group for VRF, on page 953</a> . |

|        | Command or Action                                                                                       | Purpose                                                                                                                                                                 |
|--------|---------------------------------------------------------------------------------------------------------|-------------------------------------------------------------------------------------------------------------------------------------------------------------------------|
| Step 8 | <b>application-id</b> <i>number</i><br><b>Example:</b><br>Router(config-mqos)# <b>application-id 25</b> | (Optional) Specifies the application identification number of the multicast QoS group. This value is configured to enable admission control to the multicast QoS group. |

## Configuring a Default Multicast QoS Group for VRF

Each virtual routing and forwarding (VRF) instance that is defined must match a defined MQoS group to avoid multicast stream crosstalk between VRFs. To avoid potential crosstalk, define a default MQoS group that is assigned to the VRF whenever the multicast traffic in the VRF does not match an existing MQoS group.

### Procedure

|        | Command or Action                                                                                                                                                                                                                                                                              | Purpose                                                                                                                                                                                    |
|--------|------------------------------------------------------------------------------------------------------------------------------------------------------------------------------------------------------------------------------------------------------------------------------------------------|--------------------------------------------------------------------------------------------------------------------------------------------------------------------------------------------|
| Step 1 | <b>enable</b><br><b>Example:</b><br>Router> enable                                                                                                                                                                                                                                             | Enables privileged EXEC mode. <ul style="list-style-type: none"> <li>• Enter your password if prompted.</li> </ul>                                                                         |
| Step 2 | <b>configure terminal</b><br><b>Example:</b><br>Router# configure terminal                                                                                                                                                                                                                     | Enters global configuration mode.                                                                                                                                                          |
| Step 3 | <b>cable multicastgroup-qos</b> <i>number</i> <b>scn</b> <i>service-class-name</i><br><b>control</b> { <b>single</b>   <b>aggregate</b> [ <b>limit</b> <i>max-sessions</i> ]}<br><b>Example:</b><br>Router(config-mqos)# <b>cable multicast group-qos 5</b><br><b>scn name1 control single</b> | (Optional) Configures a QoS profile that can be applied to a multicast QoS group.                                                                                                          |
| Step 4 | <b>cable multicast qos group</b> <i>id</i> <b>priority 255 global</b><br><b>Example:</b><br>Router(config)# <b>cable multicast qos group 2</b><br><b>priority 255 global</b>                                                                                                                   | Configures a default multicast QoS group and enters multicast QoS configuration mode.                                                                                                      |
| Step 5 | <b>session-range</b> <b>224.0.0.0 224.0.0.0</b><br><b>Example:</b><br>Router(config-mqos)# <b>session-range 224.0.0.0</b><br><b>224.0.0.0</b>                                                                                                                                                  | Specifies the session-range IP address and IP mask of the default multicast QoS group. By entering 224.0.0.0 for the IP address and the IP mask you cover all possible multicast sessions. |
| Step 6 | <b>vrf</b> <i>name</i><br><b>Example:</b>                                                                                                                                                                                                                                                      | Specifies the name of the virtual routing and forwarding (VRF) instance.                                                                                                                   |

|               | Command or Action                                                                                       | Purpose                                                                                                                                                                 |
|---------------|---------------------------------------------------------------------------------------------------------|-------------------------------------------------------------------------------------------------------------------------------------------------------------------------|
|               | Router(config-mqos) # <b>vrf name1</b>                                                                  |                                                                                                                                                                         |
| <b>Step 7</b> | <b>application-id</b> <i>number</i><br><b>Example:</b><br>Router(config-mqos) # <b>application-id 5</b> | (Optional) Specifies the application identification number of the multicast QoS group. This value is configured to enable admission control to the multicast QoS group. |

## Verifying Configuration of the Multicast VPN and DOCSIS 3.0 Multicast QoS Support

To verify the configuration of the Multicast VPN and DOCSIS 3.0 Multicast QoS Support feature, use the **show** commands described below.

- To show the configuration parameters for multicast sessions on a specific bundle, use the **show interface bundle *number* multicast-sessions** command as shown in the following example:

```
Router# show interface bundle 1 multicast-sessions
Multicast Sessions on Bundle1
Group          Interface    GC   SAID  SFID  GQC  GEn  RefCount  GC-Interface  State
234.1.1.45     Bundle1.1   1    8193  ---   1    5    1          Bundle1       ACTIVE
234.1.1.46     Bundle1.1   1    8193  ---   1    5    1          Bundle1       ACTIVE
234.1.1.47     Bundle1.1   1    8193  ---   1    5    1          Bundle1       ACTIVE
Aggregate Multicast Sessions on Bundle1
Aggregate Sessions for SAID 8193 GQC 1 CurrSess 3
Group          Interface    GC   SAID  SFID  AggGQC  GEn  RefCount  GC-Interface
234.1.1.45     Bundle1.1   1    8193  ---   1        5    1          Bundle1
234.1.1.46     Bundle1.1   1    8193  ---   1        5    1          Bundle1
234.1.1.47     Bundle1.1   1    8193  ---   1        5    1          Bundle1
```

- To show the configuration parameters for multicast sessions on a specific cable, use the **show interface cable *ip-addr* multicast-sessions** command as shown in the following example:

```
Router# show interface cable 7/0/0 multicast-sessions
Default Multicast Service Flow 3 on Cable7/0/0
Multicast Sessions on Cable7/0/0
Group          Interface    GC   SAID  SFID  GQC  GEn  RefCount  GC-Interface  State
234.1.1.45     Bundle1.1   1    8193  24    1    5    1          Bundle1       ACTIVE
234.1.1.46     Bundle1.1   1    8193  24    1    5    1          Bundle1       ACTIVE
234.1.1.47     Bundle1.1   1    8193  24    1    5    1          Bundle1       ACTIVE
Aggregate Multicast Sessions on Cable7/0/0
Aggregate Sessions for SAID 8193 SFID 24 GQC 1 CurrSess 3
Group          Interface    GC   SAID  SFID  AggGQC  GEn  RefCount  GC-Interface
234.1.1.45     Bundle1.1   1    8193  24    1        5    1          Bundle1
234.1.1.46     Bundle1.1   1    8193  24    1        5    1          Bundle1
234.1.1.47     Bundle1.1   1    8193  24    1        5    1          Bundle1
```

- To show the MSAID multicast group subinterface mapping, use the **show interface cable *address* modem** command as shown in the following example:

```
Router# show interface cable 6/1/0 modem
SID  Priv Type      State      IP address      method  MAC address      Dual
bits
9    11  modem  online(pt)  101.1.0.6      dhcp    0006.28f9.8c79  N
```

|      |    |           |            |            |        |                |   |
|------|----|-----------|------------|------------|--------|----------------|---|
| 9    | 11 | host      | unknown    | 111.1.1.45 | dhcp   | 0018.1952.a859 | N |
| 10   | 10 | modem     | online(pt) | 101.1.0.5  | dhcp   | 0006.5305.ac19 | N |
| 10   | 10 | host      | unknown    | 111.1.0.3  | dhcp   | 0018.1952.a85a | N |
| 13   | 10 | modem     | online(pt) | 101.1.0.3  | dhcp   | 0014.f8c1.fdlc | N |
| 8195 | 10 | multicast | unknown    | 224.1.1.51 | static | 0000.0000.0000 | N |
| 8195 | 10 | multicast | unknown    | 224.1.1.49 | static | 0000.0000.0000 | N |
| 8195 | 10 | multicast | unknown    | 224.1.1.50 | static | 0000.0000.0000 | N |

## Configuration Examples for the Multicast VPN and DOCSIS 3.0 Multicast QoS Support

This section provides the following configuration examples:

### Example: Configuring Group QoS and Group Encryption Profiles



**Note** To add group QoS and group encryption profiles to a QoS group, you must configure each profile first before configuring the QoS group.

In the following example, QoS profile 3 and encryption profile 35 are configured.

```
configure terminal
cable multicast group-qos 3 scn name1 control single
cable multicast group-encryption 35 algorithm 56bit-des
```

### Example: Configuring a QoS Group

In the following example, QoS group 2 is configured with a priority of 6 and global application. To QoS group 2, QoS profile 3 and encryption profile 35 are applied. Other parameters are configured for QoS group 2 including application type, session range, ToS, and VRF.

```
cable multicast qos group 2 priority 6 global
group-encryption 35
group-qos 3
session-range 224.10.10.01 255.255.255.254
tos 1 6 15
vrf vrf-name1
application-id 44
```

## Additional References

The following sections provide references related to the Multicast VPN and DOCSIS 3.0 Multicast QoS Support.

**Related Documents**

| Related Topic       | Document Title                                                                                                                                                                                                                 |
|---------------------|--------------------------------------------------------------------------------------------------------------------------------------------------------------------------------------------------------------------------------|
| CMTS cable commands | <i>Cisco CMTS Cable Command Reference</i><br><a href="http://www.cisco.com/c/en/us/td/docs/cable/cmts/cmd_ref/b_cmts_cable_cmd_ref.html">http://www.cisco.com/c/en/us/td/docs/cable/cmts/cmd_ref/b_cmts_cable_cmd_ref.html</a> |

**Standards**

| Standard                                                                                                                              | Title |
|---------------------------------------------------------------------------------------------------------------------------------------|-------|
| No new or modified standards are supported by this feature, and support for existing standards has not been modified by this feature. | —     |

**MIBs**

| MIB                                                                                                                         | MIBs Link                                                                                                                                                                                                              |
|-----------------------------------------------------------------------------------------------------------------------------|------------------------------------------------------------------------------------------------------------------------------------------------------------------------------------------------------------------------|
| No new or modified MIBs are supported by this feature, and support for existing MIBs has not been modified by this feature. | To locate and download MIBs for selected platforms, Cisco IOS releases, and feature sets, use Cisco MIB Locator found at the following URL:<br><a href="http://www.cisco.com/go/mibs">http://www.cisco.com/go/mibs</a> |

**RFCs**

| RFC      | Title                                                |
|----------|------------------------------------------------------|
| RFC 2236 | <i>Internet Group Management Protocol, Version 2</i> |

**Technical Assistance**

| Description                                                                                                                                                                                                                                                                                                                                                                                                                                                                                                                                                             | Link                                                                            |
|-------------------------------------------------------------------------------------------------------------------------------------------------------------------------------------------------------------------------------------------------------------------------------------------------------------------------------------------------------------------------------------------------------------------------------------------------------------------------------------------------------------------------------------------------------------------------|---------------------------------------------------------------------------------|
| <p>The Cisco Support website provides extensive online resources, including documentation and tools for troubleshooting and resolving technical issues with Cisco products and technologies.</p> <p>To receive security and technical information about your products, you can subscribe to various services, such as the Product Alert Tool (accessed from Field Notices), the Cisco Technical Services Newsletter, and Really Simple Syndication (RSS) Feeds.</p> <p>Access to most tools on the Cisco Support website requires a Cisco.com user ID and password.</p> | <a href="http://www.cisco.com/techsupport">http://www.cisco.com/techsupport</a> |



# Feature Information for Multicast VPN and DOCSIS3.0 Multicast QoS Support

Use Cisco Feature Navigator to find information about the platform support and software image support. Cisco Feature Navigator enables you to determine which software images support a specific software release, feature set, or platform. To access Cisco Feature Navigator, go to the <https://cfmg.cisco.com/> link. An account on the Cisco.com page is not required.



**Note** The following table lists the software release in which a given feature is introduced. Unless noted otherwise, subsequent releases of that software release train also support that feature.

*Table 205: Feature Information for Multicast VPN and DOCSIS3.0 Multicast QoS Support*

| Feature Name                                      | Releases                    | Feature Information                                                                                               |
|---------------------------------------------------|-----------------------------|-------------------------------------------------------------------------------------------------------------------|
| Multicast VPN and DOCSIS3.0 multicast QoS support | Cisco IOS XE Everest 16.6.1 | This feature was integrated into Cisco IOS XE Everest 16.5.1 on the Cisco cBR Series Converged Broadband Routers. |





## CHAPTER 56

# EtherChannel for the Cisco CMTS

This document describes the features, benefits and configuration of Cisco EtherChannel technology on the Cisco Cable Modem Termination System (CMTS).

EtherChannel is a technology by which to configure and aggregate multiple physical Ethernet connections to form a single logical port with higher bandwidth. The first EtherChannel port configured on the Cisco CMTS serves as the EtherChannel bundle primary by default, and each subsidiary interface interacts with the network using the MAC address of the EtherChannel bundle primary.

EtherChannel ports reside on a routing or bridging end-point. The router or switch uses EtherChannel to increase bandwidth utilization in either half- or full-duplex mode, and load balances the traffic across the multiple physical connections.

EtherChannel on the Cisco CMTS supports inter-VLAN routing with multiple devices and standards, and supports Ten Gigabit EtherChannel (GEC) on the Cisco cBR series routers.

Your software release may not support all the features that are documented in this module. For the latest feature information and caveats, see the release notes for your platform and software release. The Feature Information Table at the end of this document provides information about the documented features and lists the releases in which each feature is supported.

Use Cisco Feature Navigator to find information about platform support and Cisco software image support. To access Cisco Feature Navigator, go to <http://tools.cisco.com/ITDIT/CFN/>. An account on <http://www.cisco.com/> is not required.

### Contents

- [Hardware Compatibility Matrix for the Cisco cBR Series Routers, on page 960](#)
- [Restrictions for EtherChannel on the Cisco CMTS, on page 961](#)
- [Information About EtherChannel on the Cisco CMTS, on page 961](#)
- [How to Configure EtherChannel on the Cisco CMTS, on page 962](#)
- [Verifying EtherChannel on the Cisco CMTS, on page 964](#)
- [Configuration Examples for EtherChannel on the Cisco CMTS, on page 965](#)
- [Additional References, on page 966](#)
- [Feature Information for EtherChannel on Cisco CMTS, on page 967](#)

# Hardware Compatibility Matrix for the Cisco cBR Series Routers



**Note** The hardware components that are introduced in a given Cisco IOS-XE Release are supported in all subsequent releases unless otherwise specified.

**Table 206: Hardware Compatibility Matrix for the Cisco cBR Series Routers**

| Cisco CMTS Platform                    | Processor Engine                                                                                                                                                                                  | Interface Cards                                                                                                                                                                                                                                                                                                                                                                                                                                                                                                                                                                                                                                                                                                                                                                                 |
|----------------------------------------|---------------------------------------------------------------------------------------------------------------------------------------------------------------------------------------------------|-------------------------------------------------------------------------------------------------------------------------------------------------------------------------------------------------------------------------------------------------------------------------------------------------------------------------------------------------------------------------------------------------------------------------------------------------------------------------------------------------------------------------------------------------------------------------------------------------------------------------------------------------------------------------------------------------------------------------------------------------------------------------------------------------|
| Cisco cBR-8 Converged Broadband Router | <p><b>Cisco IOS-XE Release 16.5.1 and Later Releases</b></p> <p>Cisco cBR-8 Supervisor:</p> <ul style="list-style-type: none"> <li>• PID—CBR-SUP-250G</li> <li>• PID—CBR-CCAP-SUP-160G</li> </ul> | <p><b>Cisco IOS-XE Release 16.5.1 and Later Releases</b></p> <p>Cisco cBR-8 CCAP Line Cards:</p> <ul style="list-style-type: none"> <li>• PID—CBR-LC-8D30-16U30</li> <li>• PID—CBR-LC-8D31-16U30</li> <li>• PID—CBR-RF-PIC</li> <li>• PID—CBR-RF-PROT-PIC</li> <li>• PID—CBR-CCAP-LC-40G</li> <li>• PID—CBR-CCAP-LC-40G-R</li> <li>• PID—CBR-CCAP-LC-G2-R</li> <li>• PID—CBR-SUP-8X10G-PIC</li> <li>• PID—CBR-2X100G-PIC</li> </ul> <p>Digital PICs:</p> <ul style="list-style-type: none"> <li>• PID—CBR-DPIC-8X10G</li> <li>• PID—CBR-DPIC-2X100G</li> </ul> <p>Cisco cBR-8 Downstream PHY Module:</p> <ul style="list-style-type: none"> <li>• PID—CBR-D31-DS-MOD</li> </ul> <p>Cisco cBR-8 Upstream PHY Modules:</p> <ul style="list-style-type: none"> <li>• PID—CBR-D31-US-MOD</li> </ul> |



**Note** Do not use DPICs (8X10G and 2x100G) to forward IP traffic, as it may cause buffer exhaustion, leading to line card reload.

The only allowed traffic on a DPIC interface is DEPI, UEPI, and GCP traffic from the Cisco cBR-8 router to Remote PHY devices. Other traffic such as DHCP, SSH, and UTSC should flow via another router, since DPICs cannot be used for normal routing.

## Restrictions for EtherChannel on the Cisco CMTS

- EtherChannel on the Cisco CMTS is limited to Network Layer 3 functions, and does not support Data-Link Layer 2 EtherChannel functions as with certain other Cisco product platforms.
- The Port Aggregation Protocol (PAgP) is not supported on the Cisco CMTS as with other Cisco product platforms (such as the CatOS switch).
- Only the IEEE 802.1Q trunking protocol is supported on the Cisco CMTS. ATM trunking is not supported on the Cisco cBR series routers.
- The maximum supported links per bundle is 8.
- EtherChannel on Cisco CMTS supports only physical ports or interfaces that have the same speed.
- EtherChannel on the Cisco cBR series routers does not support MQC QoS. You can use Equal Cost Multi Path (ECMP) load balancing instead of EtherChannel.
- Layer 3 configurations on member interfaces of EtherChannel are not supported.
- MAC Address Accounting feature on port channel is not supported.

## Information About EtherChannel on the Cisco CMTS

This section contains the following:

### Introduction to EtherChannel on the Cisco CMTS

EtherChannel is based on proven industry-standard technology. The Cisco CMTS supports EtherChannel with several benefits, including the following:

- EtherChannel on the Cisco CMTS supports subsecond convergence times.
- EtherChannel can be used to connect two switch devices together, or to connect a router with a switch.
- A single EtherChannel connection supports a higher bandwidth between the two devices.
- The logical port channels on either Cisco CMTS platform provide fault-tolerant, high-speed links between routers, switches, and servers.
- EtherChannel offers redundancy and high availability on the Cisco CMTS. Failure of one connection causes a switch or router to use load balancing across the other connections in the EtherChannel.
- Load balancing on the Cisco CMTS supports dynamic link addition and removal without traffic interruption.
- EtherChannel supports inter-VLAN trunking. Trunking carries traffic from several VLANs over a point-to-point link between the two devices. The network provides inter-VLAN communication with trunking between the Cisco CMTS router and one or more switches. In a campus network, trunking is

configured over an EtherChannel link to carry the multiple VLAN information over a high-bandwidth channel.

## Cisco Ten Gigabit EtherChannel on the Cisco cBR Series Routers

Cisco Ten Gigabit EtherChannel (GEC) is high-performance Ethernet technology that provides gigabit-per-second transmission rates. It provides flexible, scalable bandwidth with resiliency and load sharing across links for switches, router interfaces, and servers.

Ten GEC on the Cisco cBR series routers with the following EtherChannel capabilities:

- Supports IEEE 802.1Q encapsulation for inter-VLAN networking.
- Supports a maximum of eight physical Ten Gigabit Ethernet ports to be combined as one logical EtherChannel link.
- Supports bandwidth up to 40 Gbps (half duplex) for a combined total of up to 80 Gbps (full duplex).

## How to Configure EtherChannel on the Cisco CMTS

This section contains the following:

### Configuring Ten Gigabit EtherChannel on the Cisco CMTS

#### Before you begin

- Ten Gigabit Ethernet cabling is completed and the ports are operational on the router and network.
- LAN interfaces are configured and operational on the router and network, with IP addresses and subnet masks.



---

**Note** The Cisco cBR series routers support up to eight physical connectors to be configured as one logical Ten GEC port.

---

#### SUMMARY STEPS

1. **enable**
2. **configure terminal**
3. **interface port-channel *n***
4. **exit**
5. **interface tengigabitethernet *slot/subslot/port***
6. **shutdown**
7. Use one of the following commands:
  - For static Ten GEC configuration, use the **channel-group *number*** command.
  - For dynamic Ten GEC configuration, use the **channel-group *number* mode {active | passive}** command.
8. **no shutdown**

## 9. end

## DETAILED STEPS

|        | Command or Action                                                                                                                 | Purpose                                                                                                                                                                                                                                                                                                                                                                                                                                                                                                                                                                                                                                                                                                                                                                  |
|--------|-----------------------------------------------------------------------------------------------------------------------------------|--------------------------------------------------------------------------------------------------------------------------------------------------------------------------------------------------------------------------------------------------------------------------------------------------------------------------------------------------------------------------------------------------------------------------------------------------------------------------------------------------------------------------------------------------------------------------------------------------------------------------------------------------------------------------------------------------------------------------------------------------------------------------|
| Step 1 | <b>enable</b><br><b>Example:</b><br>Router> <b>enable</b>                                                                         | Enables privileged EXEC mode. <ul style="list-style-type: none"> <li>• Enter your password if prompted.</li> </ul>                                                                                                                                                                                                                                                                                                                                                                                                                                                                                                                                                                                                                                                       |
| Step 2 | <b>configure terminal</b><br><b>Example:</b><br>Router# <b>configure terminal</b>                                                 | Enters global configuration mode.                                                                                                                                                                                                                                                                                                                                                                                                                                                                                                                                                                                                                                                                                                                                        |
| Step 3 | <b>interface port-channel <i>n</i></b><br><b>Example:</b><br>Router(config)# <b>interface port-channel 1</b>                      | <p>Creates an EtherChannel interface. The first EtherChannel interface configured becomes the bundle primary for all ports in the EtherChannel group. The MAC address of the first EtherChannel interface is the MAC address for all EtherChannel interfaces in the group.</p> <p>To remove an EtherChannel interface from the EtherChannel group, use the <b>no</b> form of this command.</p> <p>If the first EtherChannel interface in the group is later removed, the second EtherChannel interface in the group becomes the bundle primary by default.</p> <p>Repeat this step on every EtherChannel port to be bundled into a Ten GEC group. This configuration must be present on all EtherChannel interfaces before the EtherChannel group can be configured.</p> |
| Step 4 | <b>exit</b><br><b>Example:</b><br>Router(config-if)# <b>exit</b>                                                                  | Exits interface configuration mode and returns to global configuration mode.                                                                                                                                                                                                                                                                                                                                                                                                                                                                                                                                                                                                                                                                                             |
| Step 5 | <b>interface tengigabitethernet <i>slot/subslot/port</i></b><br><b>Example:</b><br>Router# <b>interface gigabitethernet 4/1/0</b> | <p>Selects the Ten Gigabit Ethernet interface that you wish to add as a member EtherChannel link in the EtherChannel bundle, and enters interface configuration mode.</p> <p><b>Note</b> We recommend that the link being added to the Cisco CMTS EtherChannel be shut down prior to configuring it as a member of the EtherChannel. Use the <b>shutdown</b> command in interface configuration mode immediately before completing the following steps in this procedure.</p>                                                                                                                                                                                                                                                                                            |
| Step 6 | <b>shutdown</b><br><b>Example:</b>                                                                                                | Shuts down the interface selected in step 5 before configuring it as a member of the EtherChannel.                                                                                                                                                                                                                                                                                                                                                                                                                                                                                                                                                                                                                                                                       |

|               | Command or Action                                                                                                                                                                                                                                                                                                                                                                                                  | Purpose                                                                                                                                                                                                                                                      |
|---------------|--------------------------------------------------------------------------------------------------------------------------------------------------------------------------------------------------------------------------------------------------------------------------------------------------------------------------------------------------------------------------------------------------------------------|--------------------------------------------------------------------------------------------------------------------------------------------------------------------------------------------------------------------------------------------------------------|
|               | Router(config-if)# <b>shutdown</b>                                                                                                                                                                                                                                                                                                                                                                                 |                                                                                                                                                                                                                                                              |
| <b>Step 7</b> | <p>Use one of the following commands:</p> <ul style="list-style-type: none"> <li>For static Ten GEC configuration, use the <b>channel-group number</b> command.</li> <li>For dynamic Ten GEC configuration, use the <b>channel-group number mode {active   passive}</b> command.</li> </ul> <p><b>Example:</b></p> <pre>Router(config-if)# channel-group 1 or Router(config-if)# channel-group 1 mode active</pre> | <p>Adds the Ten Gigabit Ethernet interface to the EtherChannel Group, associating that interface with an EtherChannel link.</p> <p>To remove an EtherChannel group and the associated ports from the Cisco CMTS, use the <b>no</b> form of this command.</p> |
| <b>Step 8</b> | <p><b>no shutdown</b></p> <p><b>Example:</b></p> <pre>Router(config-if)# no shutdown</pre>                                                                                                                                                                                                                                                                                                                         | Enables the interface on which EtherChannel is configured.                                                                                                                                                                                                   |
| <b>Step 9</b> | <p><b>end</b></p> <p><b>Example:</b></p> <pre>Router(config)# end</pre>                                                                                                                                                                                                                                                                                                                                            | <p>Returns to privileged EXEC mode.</p> <p>IP traffic should be visible on the network with completion of the above steps.</p>                                                                                                                               |

## Troubleshooting Tips

Once interface operations are confirmed (prior to this procedure), and EtherChannel configurations have been verified (next procedure), any difficulty experienced through the EtherChannel links may pertain to inter-VLAN or IP routing on the network, or perhaps very high bandwidth consumption.

## What to Do Next

Additional IP, access list, inter-VLAN or load balancing configurations may be made to the Cisco CMTS and these changes will be supported in the running EtherChannel configuration without service disruption from EtherChannel.

## Verifying EtherChannel on the Cisco CMTS

Links can be added or removed from an EtherChannel interface without traffic interruption. If an Ethernet link in an EtherChannel interface fails, traffic previously carried over the failed link switches to the remaining links within the EtherChannel. There are a number of events that can cause a link to be added or removed including adding or removing a link using commands and simulating link failure and recovery (as with (no)shutdown links).



Cisco EtherChannel supports online insertion and removal (OIR) of field-replaceable units (FRUs) in the Cisco CMTS chassis. Ports that remain active during OIR of one FRU will take over and support the traffic bandwidth requirements without service disruption. However, OIR is not described in this procedure.

### Procedure

|               | Command or Action                                                                                              | Purpose                                                                                                               |
|---------------|----------------------------------------------------------------------------------------------------------------|-----------------------------------------------------------------------------------------------------------------------|
| <b>Step 1</b> | <b>enable</b><br><b>Example:</b><br>Router> <b>enable</b>                                                      | Enables privileged EXEC mode.<br><ul style="list-style-type: none"> <li>• Enter your password if prompted.</li> </ul> |
| <b>Step 2</b> | <b>show interface port-channel <i>n</i></b><br><b>Example:</b><br>Router# <b>show interface port-channel 1</b> | Verifies the EtherChannel configuration on the Cisco CMTS for the selected EtherChannel group.                        |

## Configuration Examples for EtherChannel on the Cisco CMTS

The following example illustrates Ten Gigabit EtherChannel information for the port-channel interface of 2.

This configuration is comprised of three Ten GEC port channels as follows:

- Member 0 is the Ten GEC interface bundle primary.
- Member 2 is the final subsidiary interface in this Ten GEC group.
- These three port-channel interfaces (members) comprise one Ten GEC group that is set up with a Ten GEC peer on the network.

```
Router# show interface port-channel 2
Port-channel2 is up, line protocol is up
Hardware is GEChannel, address is 8888.8888.8888 (bia 0000.0000.0000)
Internet address is 101.101.101.1/16
MTU 1500 bytes, BW 3000000 Kbit, DLY 10 usec,
    reliability 255/255, txload 1/255, rxload 1/255
Encapsulation ARPA, loopback not set
Keepalive set (10 sec)
ARP type: ARPA, ARP Timeout 04:00:00
  No. of members in this channel: 3
  No. of configured members in this channel: 3
  No. of passive members in this channel: 0
  No. of active members in this channel: 3
    Member 0 : TenGigabitEthernet4/1/0 , Full-duplex, 1000Mb/s
    Member 1 : TenGigabitEthernet4/1/1 , Full-duplex, 1000Mb/s
    Member 2 : TenGigabitEthernet4/1/2 , Full-duplex, 1000Mb/s
  No. of Non-active members in this channel: 0
Last input 00:00:02, output never, output hang never
Last clearing of "show interface" counters never
Input queue: 0/225/0/0 (size/max/drops/flushes); Total output drops: 0
Queueing strategy: fifo
Output queue: 0/120 (size/max)
30 second input rate 17292000 bits/sec, 9948 packets/sec
30 second output rate 17315000 bits/sec, 9935 packets/sec
```

```

866398790 packets input, 3324942446 bytes, 0 no buffer
Received 2 broadcasts, 0 runts, 0 giants, 0 throttles
0 input errors, 0 CRC, 0 frame, 0 overrun, 0 ignored
0 watchdog, 0 multicast, 0 pause input
0 input packets with dribble condition detected
866394055 packets output, 3323914794 bytes, 0 underruns
0 output errors, 0 collisions, 0 interface resets
0 babbles, 0 late collision, 0 deferred
0 lost carrier, 0 no carrier, 0 pause output
0 output buffer failures, 0 output buffers swapped out

```

## Additional References

### Related Documents

| Related Topic                                   | Document Title                                                                                                                                                                                                                                                                                                                                                                                                                                                                                                                                                                                                                                                                                                                                            |
|-------------------------------------------------|-----------------------------------------------------------------------------------------------------------------------------------------------------------------------------------------------------------------------------------------------------------------------------------------------------------------------------------------------------------------------------------------------------------------------------------------------------------------------------------------------------------------------------------------------------------------------------------------------------------------------------------------------------------------------------------------------------------------------------------------------------------|
| EtherChannel for Cisco Products                 | <ul style="list-style-type: none"> <li>• Cisco EtherChannel home page<br/><a href="http://www.cisco.com/warp/public/cc/techno/lnty/etty/fsetch/index.shtml">http://www.cisco.com/warp/public/cc/techno/lnty/etty/fsetch/index.shtml</a></li> <li>• Cisco EtherChannel Technology white paper<br/><a href="http://www.cisco.com/en/US/tech/tk389/tk213/technologies_white_paper09186a0080092944.shtml">http://www.cisco.com/en/US/tech/tk389/tk213/technologies_white_paper09186a0080092944.shtml</a></li> </ul>                                                                                                                                                                                                                                           |
| Configuring Additional Devices for EtherChannel | <ul style="list-style-type: none"> <li>• <i>Configuring EtherChannel and 802.1Q Trunking Between a Catalyst 2950 and a Router (inter-VLAN Routing)</i><br/><a href="http://www.cisco.com/c/en/us/support/docs/switches/catalyst-2950-series-switches/24042-158.html">http://www.cisco.com/c/en/us/support/docs/switches/catalyst-2950-series-switches/24042-158.html</a></li> <li>• <i>Configuring EtherChannel and 802.1Q Trunking Between Catalyst 2900XL/3500XL and Catalyst 2940, 2950/2955, and 2970 Switches</i><br/><a href="http://www.cisco.com/c/en/us/support/docs/switches/catalyst-2900-xl-series-switches/21041-131.html">http://www.cisco.com/c/en/us/support/docs/switches/catalyst-2900-xl-series-switches/21041-131.html</a></li> </ul> |

### Standards and RFCs

| Standards                     | Title                                                                                                                                                                                                                                                                                |
|-------------------------------|--------------------------------------------------------------------------------------------------------------------------------------------------------------------------------------------------------------------------------------------------------------------------------------|
| IEEE Std 802.1Q, 2003 Edition | IEEE Std 802.1Q, 2003 Edition (Incorporates IEEE Std 802.1Q-1998, IEEE Std 802.1u-2001, IEEE Std 802.1v-2001, and IEEE Std 802.1s-2002)<br><br><a href="http://ieeexplore.ieee.org/xpl/tocresult.jsp?isNumber=27089">http://ieeexplore.ieee.org/xpl/tocresult.jsp?isNumber=27089</a> |

**Technical Assistance**

| Description                                                                                                                                                                                                                                                                                                                                                                                                                                                                                                                                                             | Link                                                                                        |
|-------------------------------------------------------------------------------------------------------------------------------------------------------------------------------------------------------------------------------------------------------------------------------------------------------------------------------------------------------------------------------------------------------------------------------------------------------------------------------------------------------------------------------------------------------------------------|---------------------------------------------------------------------------------------------|
| <p>The Cisco Support website provides extensive online resources, including documentation and tools for troubleshooting and resolving technical issues with Cisco products and technologies.</p> <p>To receive security and technical information about your products, you can subscribe to various services, such as the Product Alert Tool (accessed from Field Notices), the Cisco Technical Services Newsletter, and Really Simple Syndication (RSS) Feeds.</p> <p>Access to most tools on the Cisco Support website requires a Cisco.com user ID and password.</p> | <a href="http://www.cisco.com/cisco/web/support">http://www.cisco.com/cisco/web/support</a> |

## Feature Information for EtherChannel on Cisco CMTS

Use Cisco Feature Navigator to find information about the platform support and software image support. Cisco Feature Navigator enables you to determine which software images support a specific software release, feature set, or platform. To access Cisco Feature Navigator, go to the <https://cfmg.cisco.com/> link. An account on the Cisco.com page is not required.



**Note** The following table lists the software release in which a given feature is introduced. Unless noted otherwise, subsequent releases of that software release train also support that feature.

*Table 207: Feature Information for EtherChannel on Cisco CMTS*

| Feature Name               | Releases                    | Feature Information                                                                                              |
|----------------------------|-----------------------------|------------------------------------------------------------------------------------------------------------------|
| EtherChannel on Cisco CMTS | Cisco IOS XE Everest 16.6.1 | This feature was integrated into Cisco IOS XE Everest 16.6.1 on the Cisco cBR Series Converged Broadband Router. |





## CHAPTER 57

# Flow-Based per Port-Channel Load Balancing

The Flow-Based per Port-Channel Load Balancing feature allows different flows of traffic over a Ten Gigabit EtherChannel (GEC) interface to be identified based on the packet header and then mapped to the different member links of the port channel. This feature enables you to apply flow-based load balancing and VLAN-manual load balancing to specific port channels.

Your software release may not support all the features that are documented in this module. For the latest feature information and caveats, see the release notes for your platform and software release. The Feature Information Table at the end of this document provides information about the documented features and lists the releases in which each feature is supported.

Use Cisco Feature Navigator to find information about platform support and Cisco software image support. To access Cisco Feature Navigator, go to <http://tools.cisco.com/ITDIT/CFN/>. An account on <http://www.cisco.com/> is not required.

### Contents

- [Hardware Compatibility Matrix for the Cisco cBR Series Routers, on page 969](#)
- [Restrictions for Flow-Based per Port-Channel Load Balancing, on page 970](#)
- [Information About Flow-Based per Port-Channel Load Balancing, on page 971](#)
- [How to Enable Flow-Based per Port-Channel Load Balancing, on page 973](#)
- [Verifying Load Balancing Configuration on a Ten GEC Interface, on page 974](#)
- [Configuration Examples for Flow-Based per Port-Channel Load Balancing, on page 976](#)
- [Additional References, on page 977](#)
- [Feature Information for Flow-Based per Port-Channel Load Balancing, on page 977](#)

## Hardware Compatibility Matrix for the Cisco cBR Series Routers



---

**Note** The hardware components that are introduced in a given Cisco IOS-XE Release are supported in all subsequent releases unless otherwise specified.

---

Table 208: Hardware Compatibility Matrix for the Cisco cBR Series Routers

| Cisco CMTS Platform                    | Processor Engine                                                                                                                                                                                  | Interface Cards                                                                                                                                                                                                                                                                                                                                                                                                                                                                                                                                                                                                                                                                                                                                                                                 |
|----------------------------------------|---------------------------------------------------------------------------------------------------------------------------------------------------------------------------------------------------|-------------------------------------------------------------------------------------------------------------------------------------------------------------------------------------------------------------------------------------------------------------------------------------------------------------------------------------------------------------------------------------------------------------------------------------------------------------------------------------------------------------------------------------------------------------------------------------------------------------------------------------------------------------------------------------------------------------------------------------------------------------------------------------------------|
| Cisco cBR-8 Converged Broadband Router | <p><b>Cisco IOS-XE Release 16.5.1 and Later Releases</b></p> <p>Cisco cBR-8 Supervisor:</p> <ul style="list-style-type: none"> <li>• PID—CBR-SUP-250G</li> <li>• PID—CBR-CCAP-SUP-160G</li> </ul> | <p><b>Cisco IOS-XE Release 16.5.1 and Later Releases</b></p> <p>Cisco cBR-8 CCAP Line Cards:</p> <ul style="list-style-type: none"> <li>• PID—CBR-LC-8D30-16U30</li> <li>• PID—CBR-LC-8D31-16U30</li> <li>• PID—CBR-RF-PIC</li> <li>• PID—CBR-RF-PROT-PIC</li> <li>• PID—CBR-CCAP-LC-40G</li> <li>• PID—CBR-CCAP-LC-40G-R</li> <li>• PID—CBR-CCAP-LC-G2-R</li> <li>• PID—CBR-SUP-8X10G-PIC</li> <li>• PID—CBR-2X100G-PIC</li> </ul> <p>Digital PICs:</p> <ul style="list-style-type: none"> <li>• PID—CBR-DPIC-8X10G</li> <li>• PID—CBR-DPIC-2X100G</li> </ul> <p>Cisco cBR-8 Downstream PHY Module:</p> <ul style="list-style-type: none"> <li>• PID—CBR-D31-DS-MOD</li> </ul> <p>Cisco cBR-8 Upstream PHY Modules:</p> <ul style="list-style-type: none"> <li>• PID—CBR-D31-US-MOD</li> </ul> |



**Note** Do not use DPICs (8X10G and 2x100G) to forward IP traffic, as it may cause buffer exhaustion, leading to line card reload.

The only allowed traffic on a DPIC interface is DEPI, UEPI, and GCP traffic from the Cisco cBR-8 router to Remote PHY devices. Other traffic such as DHCP, SSH, and UTSC should flow via another router, since DPICs cannot be used for normal routing.

## Restrictions for Flow-Based per Port-Channel Load Balancing

- Supports up to 64 Ten GEC interfaces.

- Supports up to 8 member links per Ten GEC interface.
- dot1q L2VPN is not supported over a port-channel with load-balancing vlan configured.

# Information About Flow-Based per Port-Channel Load Balancing

## Flow-Based Load Balancing

Flow-based load balancing identifies different flows of traffic based on the key fields in the data packet. For example, IPv4 source and destination IP addresses can be used to identify a flow. The various data traffic flows are then mapped to the different member links of a port channel. After the mapping is done, the data traffic for a flow is transmitted through the assigned member link. The flow mapping is dynamic and changes when there is any change in the state of a member link to which a flow is assigned. The flow mappings can also change if member links are added to or removed from the GEC interface. Multiple flows can be mapped to each member link.

## Buckets for Flow-Based Load Balancing

Load balancing dynamically maps traffic flows to the member links of a Ten GEC interface through the concept of buckets. The various defined traffic flows are mapped to the buckets and the buckets are evenly distributed among the member links. Each port channel maintains 16 buckets, with one active member link associated with each bucket. All traffic flows mapped to a bucket use the member link to which the bucket is assigned.

The router creates the buckets-to-member links mappings when you apply flow-based load balancing to a port channel and the port channel has at least one active member link. The mappings are also created when the first member link is added, or comes up, and the load-balancing method is set to flow-based.

When a member link goes down or is removed from a port channel, the buckets associated with that member link are redistributed among the other active member links in a round-robin fashion. When a member link comes up or is added to a port channel, some of the buckets associated with other links are assigned to this link.

If you change the load-balancing method, the bucket-to-member link mappings for flow-based load balancing are deleted. The mappings are also deleted if the port channel is deleted or the last member link in the port channel is deleted or goes down.

## Load Balancing on Port Channels

GEC interfaces can use either dynamic flow-based load balancing or VLAN-manual load balancing. You can configure the load-balancing method globally for all port channels or directly on specific port channels. The global configuration applies only to those port channels for which you have not explicitly configured load balancing. The port-channel configuration overrides the global configuration.

Flow-based load balancing is enabled by default at the global level. You must explicitly configure VLAN load balancing or the load-balancing method is flow-based.

The table below lists the load-balancing method that is applied to port channels based on the configuration:

**Table 209: Flow-Based Load Balancing Configuration Options**

| Global Configuration | Port-Channel Configuration | Load Balancing Applied |
|----------------------|----------------------------|------------------------|
| Not configured       | Not configured             | Flow-based             |
|                      | Flow-based                 | Flow-based             |
|                      | VLAN-manual                | VLAN-manual            |
| VLAN-manual          | Not configured             | VLAN-manual            |
|                      | Flow-based                 | Flow-based             |
|                      | VLAN-manual                | VLAN-manual            |

The table below lists the configuration that results if you change the global load-balancing method.

**Table 210: Results When Global Configuration Changes**

| Port-Channel Configuration | Global Configuration |                | Action Taken at Port-Channel           |
|----------------------------|----------------------|----------------|----------------------------------------|
| —                          | From                 | To             | —                                      |
| Not configured             | Not configured       | VLAN-manual    | Changed from flow-based to VLAN-manual |
|                            | VLAN-manual          | Not configured | Changed from VLAN-manual to flow-based |
| Configured                 | Any                  | Any            | No change                              |

The table below lists the configuration that results if you change the port-channel load-balancing method.

**Table 211: Results When Port-Channel Configuration Changes**

| Port-Channel Configuration | Global Configuration |    | Action Taken at Port-Channel |
|----------------------------|----------------------|----|------------------------------|
| —                          | From                 | To | —                            |



| Port-Channel Configuration | Global Configuration |                | Action Taken at Port-Channel           |
|----------------------------|----------------------|----------------|----------------------------------------|
| Not configured             | Not configured       | VLAN-manual    | Changed from flow-based to VLAN-manual |
|                            | Not configured       | Flow-based     | No action taken                        |
|                            | VLAN-manual          | Flow-based     | Changed from VLAN-manual to flow-based |
|                            | VLAN-manual          | Not configured | Changed from VLAN-manual to flow-based |
|                            | Flow-based           | VLAN-manual    | Changed from flow-based to VLAN-manual |
|                            | Flow-based           | Not configured | No action taken                        |
| Configured                 | Not configured       | VLAN-manual    | No action taken                        |
|                            | Not configured       | Flow-based     | Changed from VLAN-manual to flow-based |
|                            | VLAN-manual          | Flow-based     | Changed from VLAN-manual to flow-based |
|                            | VLAN-manual          | Not configured | No action taken                        |
|                            | Flow-based           | VLAN-manual    | Changed from flow-based to VLAN-manual |
|                            | Flow-based           | Not configured | Changed from flow-based to VLAN-manual |

# How to Enable Flow-Based per Port-Channel Load Balancing

## Configuring Load Balancing on a Port Channel

To configure load balancing on a port channel, perform the following steps. Repeat these steps for each GEC interface.

### Before you begin

If you have already configured your desired load-balancing method globally and want to use that method for all port channels, you need not perform this task. To configure load balancing globally, use the **port-channel load-balancing vlan-manual** command. If you do not configure the global command, flow-based load balancing is applied to all port channels.

## SUMMARY STEPS

1. **enable**
2. **configure terminal**
3. **interface port-channel** *channel-number*
4. **load-balancing** {flow | vlan}
5. **end**

## DETAILED STEPS

|        | Command or Action                                                                                                  | Purpose                                                                                                                                                                                                                                                                                                                      |
|--------|--------------------------------------------------------------------------------------------------------------------|------------------------------------------------------------------------------------------------------------------------------------------------------------------------------------------------------------------------------------------------------------------------------------------------------------------------------|
| Step 1 | <b>enable</b><br><b>Example:</b><br>Router> enable                                                                 | Enables privileged EXEC mode. <ul style="list-style-type: none"> <li>• Enter your password if prompted.</li> </ul>                                                                                                                                                                                                           |
| Step 2 | <b>configure terminal</b><br><b>Example:</b><br>Router# configure terminal                                         | Enters global configuration mode.                                                                                                                                                                                                                                                                                            |
| Step 3 | <b>interface port-channel</b> <i>channel-number</i><br><b>Example:</b><br>Router(config)# interface port-channel 1 | Enters interface configuration mode and defines the interface as a port channel.                                                                                                                                                                                                                                             |
| Step 4 | <b>load-balancing</b> {flow   vlan}<br><b>Example:</b><br>Router(config-if)# load-balancing flow                   | Applies a load-balancing method to the specific port channel. <ul style="list-style-type: none"> <li>• If you do not configure this command, the port channel uses the global load-balancing method configured with the <b>port-channel load-balancing vlan-manual</b> command. The global default is flow-based.</li> </ul> |
| Step 5 | <b>end</b><br><b>Example:</b><br>Router(config-if)# end                                                            | Exits configuration mode.                                                                                                                                                                                                                                                                                                    |

## Verifying Load Balancing Configuration on a Ten GEC Interface

- **show running-config interface port-channel** *channel-number*—Displays the port channel configuration.

Following is a sample output of this command:

```
Router# show running-config interface port-channel 62
Building configuration...

Current configuration : 108 bytes
!
```

```
interface Port-channel62
 ip address 12.1.1.1 255.255.255.0
 ipv6 address 2001:12:1:1::1/64
 mpls
```

- **show etherchannel load-balancing** — Displays the load balancing method applied to each port channel.

The following is a sample output of this command:

```
Router# show etherchannel load-balancing

EtherChannel Load-Balancing Method:
Global LB Method: flow-based

Port-Channel:                LB Method
Port-channel62                : flow-based
Port-channel63                : flow-based
```

- **show interfaces port-channel channel-number etherchannel** — Displays the bucket distribution currently in use.

The following is a sample output for an interface with load balancing set to flow-based:

```
Router(config)# show interface port-channel 62 etherchannel

All IDBs List contains 8 configured interfaces
Port: TenGigabitEthernet4/1/0 (index: 0)
Port: TenGigabitEthernet4/1/1 (index: 1)
Port: TenGigabitEthernet4/1/2 (index: 2)
Port: TenGigabitEthernet4/1/3 (index: 3)
Port: TenGigabitEthernet4/1/4 (index: 4)
Port: TenGigabitEthernet4/1/5 (index: 5)
Port: TenGigabitEthernet4/1/6 (index: 6)
Port: TenGigabitEthernet4/1/7 (index: 7)

Active Member List contains 8 interfaces
Port: TenGigabitEthernet4/1/0
    LACP Mode: Active

Port: TenGigabitEthernet4/1/1
    LACP Mode: Active

Port: TenGigabitEthernet4/1/2
    LACP Mode: Active

Port: TenGigabitEthernet4/1/3
    LACP Mode: Active

Port: TenGigabitEthernet4/1/4
    LACP Mode: Active

Port: TenGigabitEthernet4/1/5
    LACP Mode: Active

Port: TenGigabitEthernet4/1/6
    LACP Mode: Active

Port: TenGigabitEthernet4/1/7
    LACP Mode: Active

Passive Member List contains 0 interfaces
Load-Balancing method applied: flow-based
```

```

Bucket Information for Flow-Based LB:
Interface:                               Buckets
TenGigabitEthernet4/1/0:                 Bucket 0 , Bucket 1
TenGigabitEthernet4/1/1:                 Bucket 2 , Bucket 3
TenGigabitEthernet4/1/2:                 Bucket 4 , Bucket 5
TenGigabitEthernet4/1/3:                 Bucket 6 , Bucket 7
TenGigabitEthernet4/1/4:                 Bucket 8 , Bucket 9
TenGigabitEthernet4/1/5:                 Bucket 10, Bucket 11
TenGigabitEthernet4/1/6:                 Bucket 12, Bucket 13
TenGigabitEthernet4/1/7:                 Bucket 14, Bucket 15

```

## Configuration Examples for Flow-Based per Port-Channel Load Balancing

### Example: Flow-Based Load Balancing

The following example shows a configuration where flow-based load balancing is configured on port-channel 2 while the VLAN-manual method is configured globally:

```

!
no aaa new-model
port-channel load-balancing vlan-manual
ip source-route
.
.
.
interface Port-channel2
 ip address 10.0.0.1 255.255.255.0
 no negotiation auto
 load-balancing flow
!
interface Port-channel2.10
 ip rsvp authentication key 11223344
 ip rsvp authentication
!
interface Port-channel2.50
 encapsulation dot1Q 50
!
interface TenGigabitEthernet4/1/0
 no ip address
 negotiation auto
 cdp enable
 channel-group 2
!

```

## Additional References

### Technical Assistance

| Description                                                                                                                                                                                                                                                                                                                                                                                                                                                                                                                                                             | Link                                                                    |
|-------------------------------------------------------------------------------------------------------------------------------------------------------------------------------------------------------------------------------------------------------------------------------------------------------------------------------------------------------------------------------------------------------------------------------------------------------------------------------------------------------------------------------------------------------------------------|-------------------------------------------------------------------------|
| <p>The Cisco Support website provides extensive online resources, including documentation and tools for troubleshooting and resolving technical issues with Cisco products and technologies.</p> <p>To receive security and technical information about your products, you can subscribe to various services, such as the Product Alert Tool (accessed from Field Notices), the Cisco Technical Services Newsletter, and Really Simple Syndication (RSS) Feeds.</p> <p>Access to most tools on the Cisco Support website requires a Cisco.com user ID and password.</p> | <a href="http://www.cisco.com/support">http://www.cisco.com/support</a> |

## Feature Information for Flow-Based per Port-Channel Load Balancing

Use Cisco Feature Navigator to find information about the platform support and software image support. Cisco Feature Navigator enables you to determine which software images support a specific software release, feature set, or platform. To access Cisco Feature Navigator, go to the <https://cfmng.cisco.com/> link. An account on the Cisco.com page is not required.



**Note** The following table lists the software release in which a given feature is introduced. Unless noted otherwise, subsequent releases of that software release train also support that feature.

*Table 212: Feature Information for Flow-Based per Port-Channel Load Balancing*

| Feature Name                               | Releases                    | Feature Information                                                                                           |
|--------------------------------------------|-----------------------------|---------------------------------------------------------------------------------------------------------------|
| Flow-based per port-channel Load balancing | Cisco IOS XE Everest 16.6.1 | This feature was integrated into Cisco IOS XE Everest 16.6.1 on Cisco cBR Series Converged Broadband Routers. |





## CHAPTER 58

# MPLS QoS via TLV for non-L2VPN Service Flow

The MPLS QoS via TLV for non-L2VPN Service Flow feature allows to mark TC bits for MPLS L3VPN imposition packets and classify downstream packets based on TC bits of MPLS disposition packets, using vendor-specific TLVs.

- [Hardware Compatibility Matrix for the Cisco cBR Series Routers, on page 979](#)
- [Restrictions for MPLS QoS via TLV for non-L2VPN Service Flow, on page 980](#)
- [Information About MPLS QoS via TLV for non-L2VPN Service Flow, on page 981](#)
- [Configuring MPLS QoS via TLV for non-L2VPN Service Flow, on page 981](#)
- [Configuration Examples, on page 982](#)
- [Additional References, on page 986](#)
- [Feature Information for MPLS QoS via TLV for non-L2VPN Service Flow, on page 986](#)

## Hardware Compatibility Matrix for the Cisco cBR Series Routers



---

**Note** The hardware components that are introduced in a given Cisco IOS-XE Release are supported in all subsequent releases unless otherwise specified.

---

Table 213: Hardware Compatibility Matrix for the Cisco cBR Series Routers

| Cisco CMTS Platform                    | Processor Engine                                                                                                                                                                                  | Interface Cards                                                                                                                                                                                                                                                                                                                                                                                                                                                                                                                                                                                                                                                                                                                                                                                 |
|----------------------------------------|---------------------------------------------------------------------------------------------------------------------------------------------------------------------------------------------------|-------------------------------------------------------------------------------------------------------------------------------------------------------------------------------------------------------------------------------------------------------------------------------------------------------------------------------------------------------------------------------------------------------------------------------------------------------------------------------------------------------------------------------------------------------------------------------------------------------------------------------------------------------------------------------------------------------------------------------------------------------------------------------------------------|
| Cisco cBR-8 Converged Broadband Router | <p><b>Cisco IOS-XE Release 16.5.1 and Later Releases</b></p> <p>Cisco cBR-8 Supervisor:</p> <ul style="list-style-type: none"> <li>• PID—CBR-SUP-250G</li> <li>• PID—CBR-CCAP-SUP-160G</li> </ul> | <p><b>Cisco IOS-XE Release 16.5.1 and Later Releases</b></p> <p>Cisco cBR-8 CCAP Line Cards:</p> <ul style="list-style-type: none"> <li>• PID—CBR-LC-8D30-16U30</li> <li>• PID—CBR-LC-8D31-16U30</li> <li>• PID—CBR-RF-PIC</li> <li>• PID—CBR-RF-PROT-PIC</li> <li>• PID—CBR-CCAP-LC-40G</li> <li>• PID—CBR-CCAP-LC-40G-R</li> <li>• PID—CBR-CCAP-LC-G2-R</li> <li>• PID—CBR-SUP-8X10G-PIC</li> <li>• PID—CBR-2X100G-PIC</li> </ul> <p>Digital PICs:</p> <ul style="list-style-type: none"> <li>• PID—CBR-DPIC-8X10G</li> <li>• PID—CBR-DPIC-2X100G</li> </ul> <p>Cisco cBR-8 Downstream PHY Module:</p> <ul style="list-style-type: none"> <li>• PID—CBR-D31-DS-MOD</li> </ul> <p>Cisco cBR-8 Upstream PHY Modules:</p> <ul style="list-style-type: none"> <li>• PID—CBR-D31-US-MOD</li> </ul> |



**Note** Do not use DPICs (8X10G and 2x100G) to forward IP traffic, as it may cause buffer exhaustion, leading to line card reload.

The only allowed traffic on a DPIC interface is DEPI, UEPI, and GCP traffic from the Cisco cBR-8 router to Remote PHY devices. Other traffic such as DHCP, SSH, and UTSC should flow via another router, since DPICs cannot be used for normal routing.

## Restrictions for MPLS QoS via TLV for non-L2VPN Service Flow

- This feature supports only IPv4. It will not support IPv6.



- This feature does not support SNMP.
- This feature does not support dynamic service flows.
- Only up to four VPNs and eight upstream service flows per CM can be configured.
- For a VPN, only a maximum of eight DS classifiers (using TC bits in the range from 0 to 7) can be configured.
- If TC bits downstream classifiers are configured for a VPN, then the downstream MPLS packets belonging to the VPN are processed only on TC bits classification. It will not process general IP header field classification.

## Information About MPLS QoS via TLV for non-L2VPN Service Flow

The MPLS QoS via TLV for non-L2VPN Service Flow feature is a QoS enhancement based on MPLS Traffic Class (TC) bits for MPLS L3VPN. The MPLS TC bits were previously known as MPLS EXP bits. RFC 5462 has renamed the MPLS EXP field to MPLS TC field.

For upstream service flow encoding, use Cisco-specific TLV to set TC bits value for MPLS imposition packets. For downstream classifier encoding, use Cisco-specific TLV to implement downstream classification based on TC bits of MPLS disposition packets.

## Configuring MPLS QoS via TLV for non-L2VPN Service Flow



**Note** This feature is configured using a cable modem configuration file and is dependent on the general configuration of the L3VPN.

This section describes how to configure traffic class bits for MPLS imposition and disposition packets and on how to use vendor-specific TLVs with AToM L2VPN and MPLS L3VPN.

### Traffic Class for MPLS Imposition Packets

The table lists the vendor-specific TLV to be included in the cable modem configuration file to configure TC bits for MPLS imposition packets. The MPLS-TC-SET TLV is defined in the upstream and is associated with the VPN RD in upstream service flow encoding.

*Table 214: TLV to Configure TC Bits for MPLS Imposition Packets*

| TLV Name        | SubType    | Length | Value                       |
|-----------------|------------|--------|-----------------------------|
| MPLS-TC-SET TLV | 43.5.43.34 | 1      | Imposition MPLS-TC-SET bits |

### Traffic Classification for MPLS Disposition Packets

The table lists the vendor-specific TLV to be included in the cable modem configuration file to classify DS packets based on TC bits of MPLS disposition packets.

The MPLS-TC-RANGE TLV is defined only under DS classifier encodings. It supports multi-downstream flow in a CM belonging to the same MPLS L3VPN, associated with the VPN RD in downstream classifier encoding.

**Table 215: TLV to Classify TC Bits for MPLS Disposition Packets**

| TLV Name      | SubType    | Length | Value                        |
|---------------|------------|--------|------------------------------|
| MPLS-TC-RANGE | 43.5.43.35 | 2      | MPLS-TC-low and MPLS-TC-high |

## Using Vendor-Specific TLVs with AToM L2VPN and MPLS L3VPN

If both AToM L2VPN (L2 MPLS) and MPLS L3VPN (L3 MPLS) are using the same set of TLVs (MPLS-TC-SET and MPLS-TC-RANGE), then you should differentiate them. Configure the TLVs for upstream service flow encoding and downstream classifier encodings as indicated below:

### Upstream Service Flow Encoding

- For L2VPN, configure MPLS-TC-SET (43.5.43.34) and L2VPN ID (43.5.1).
- For MPLS L3VPN, configure MPLS-TC-SET (43.5.43.34) and VPN RD (43.5.1).



**Note** Do not configure the TLVs for L2VPN and MPLS L3VPN at the same time for upstream service flow encodings, as it will result in a TLV error.

### Downstream Classifier Encoding

- L2VPN—Configure MPLS-TC-RANGE (43.5.43.35) and L2VPN ID (43.5.1).
- MPLS L3VPN—Configure MPLS-TC-RANGE (43.5.43.35) and VPN RD (43.5.1).

## Configuration Examples

This section provides the following configuration examples:

### Example: Upstream Service Flow Marking TLV

The following example shows a sample CM configuration TLV for the provisioning of TC bits for MPLS disposition packets:

```

24 (Upstream Service Flow Encoding)
  S01 (Service Flow Reference)          = 2
  S06 (QoS Parameter Set Type)         = 7
  S43 (Vendor Specific Options)
    T08 (Vendor ID)                    = 00 00 0c
    T004 (VPN Route Distinguisher)     = xx xx xx xx xx xx xx xx
    S005 (Vendor specific L2VPN TLV)
    S043 (Cisco Vendor Specific)
    T034 (MPLS-TC-SET)                 = 04 # MPLSTC-SET = 4

```

## Example: Downstream Packet Classification TLV

The following example shows a sample CM configuration TLV for classifying downstream packets based on TC bits of MPLS disposition packets:

```

23 (Downstream Packet Classification Encoding)
  S01 (Classifier Reference)           = 13
  S03 (Service Flow Reference)        = 13
  S11 (IEEE 802.1P/Q Packet Classification Encodings)
  S43 (Vendor Specific Options)
    T08 (Vendor ID)                   = 00 00 0c
    S004 (VPN Route Distinguisher)    = xx xx xx xx xx xx xx xx
    S005 (Vendor specific L2VPN TLV)
      S043 (Cisco Vendor Specific)
      S035 (MPLS-TC-RANGE)            = 04 05      # MPLSTC-EGRESS_RANGE= 4 - 5

```

## Example: MPLS QoS Configuration File

The following example shows a cable modem being configured to mark TC bits for MPLS L3VPN imposition packets and classify downstream packets based on TC bits of MPLS L3VPN disposition packets, using vendor-specific TLVs:

```

CM-CONFIG
=====
03 (Net Access Control)                = 1
18 (Maximum Number of CPE)             = 16
22 (Upstream Packet Classification Encoding Block)
  S01 (Classifier Reference)             = 2
  S03 (Service Flow Reference)          = 2
  S05 (Rule Priority)                   = 2
  S09 (IP Packet Encodings)
    T01 (IP Type of Srv Rng & Mask)     = 00 20 ff
22 (Upstream Packet Classification Encoding Block)
  S01 (Classifier Reference)             = 3
  S03 (Service Flow Reference)          = 3
  S05 (Rule Priority)                   = 3
  S09 (IP Packet Encodings)
    T01 (IP Type of Srv Rng & Mask)     = 40 80 ff
22 (Upstream Packet Classification Encoding Block)
  S01 (Classifier Reference)             = 4
  S03 (Service Flow Reference)          = 4
  S05 (Rule Priority)                   = 4
  S09 (IP Packet Encodings)
    T01 (IP Type of Srv Rng & Mask)     = a0 e0 ff
23 (Downstream Packet Classification Encoding Block)
  S01 (Classifier Reference)             = 12
  S03 (Service Flow Reference)          = 12
  S05 (Rule Priority)                   = 2
  S09 (IP Packet Encodings)
    T01 (IP Type of Srv Rng & Mask)     = 00 ff ff
  S43 (Vendor Specific Options)
    T08 (Vendor ID)                     = 00 00 0c
    T004 (Unknown sub-type)              = 00 00 00 01 00 00 00 01
    T005 (Unknown sub-type)              = 2b 09 08 03 00 00 0c 23 02 01 01
23 (Downstream Packet Classification Encoding Block)
  S01 (Classifier Reference)             = 13
  S03 (Service Flow Reference)          = 13
  S05 (Rule Priority)                   = 3
  S09 (IP Packet Encodings)
    T01 (IP Type of Srv Rng & Mask)     = 00 ff ff

```

```

S43 (Vendor Specific Options)
    T08 (Vendor ID) = 00 00 0c
    T004 (Unknown sub-type) = 00 00 00 01 00 00 00 01
    T005 (Unknown sub-type) = 2b 09 08 03 00 00 0c 23 02 02 02
23 (Downstream Packet Classification Encoding Block)
    S01 (Classifier Reference) = 14
    S03 (Service Flow Reference) = 14
    S05 (Rule Priority) = 4
    S09 (IP Packet Encodings)
        T01 (IP Type of Srv Rng & Mask) = 00 ff ff
    S43 (Vendor Specific Options)
        T08 (Vendor ID) = 00 00 0c
        T004 (Unknown sub-type) = 00 00 00 01 00 00 00 01
        T005 (Unknown sub-type) = 2b 09 08 03 00 00 0c 23 02 03 03
24 (Upstream Service Flow Encodings)
    S01 (Service Flow Reference) = 1
    S06 (QoS Parameter Set Type) = 7
24 (Upstream Service Flow Encodings)
    S01 (Service Flow Reference) = 2
    S06 (QoS Parameter Set Type) = 7
    S43 (Vendor Specific Options)
        T08 (Vendor ID) = 00 00 0c
        T004 (Unknown sub-type) = 00 00 00 01 00 00 00 01
        T005 (Unknown sub-type) = 2b 08 08 03 00 00 0c 22 01 04
24 (Upstream Service Flow Encodings)
    S01 (Service Flow Reference) = 3
    S06 (QoS Parameter Set Type) = 7
    S43 (Vendor Specific Options)
        T08 (Vendor ID) = 00 00 0c
        T004 (Unknown sub-type) = 00 00 00 01 00 00 00 01
        T005 (Unknown sub-type) = 2b 08 08 03 00 00 0c 22 01 05
24 (Upstream Service Flow Encodings)
    S01 (Service Flow Reference) = 4
    S06 (QoS Parameter Set Type) = 7
    S43 (Vendor Specific Options)
        T08 (Vendor ID) = 00 00 0c
        T004 (Unknown sub-type) = 00 00 00 01 00 00 00 01
        T005 (Unknown sub-type) = 2b 08 08 03 00 00 0c 22 01 06
25 (Downstream Service Flow Encodings)
    S01 (Service Flow Reference) = 11
    S06 (QoS Parameter Set Type) = 7
    S07 (Traffic Priority) = 7
25 (Downstream Service Flow Encodings)
    S01 (Service Flow Reference) = 12
    S06 (QoS Parameter Set Type) = 7
25 (Downstream Service Flow Encodings)
    S01 (Service Flow Reference) = 13
    S06 (QoS Parameter Set Type) = 7
25 (Downstream Service Flow Encodings)
    S01 (Service Flow Reference) = 14
    S06 (QoS Parameter Set Type) = 7
25 (Downstream Service Flow Encodings)
    S01 (Service Flow Reference) = 15
    S06 (QoS Parameter Set Type) = 7
25 (Downstream Service Flow Encodings)
    S01 (Service Flow Reference) = 16
    S06 (QoS Parameter Set Type) = 7
25 (Downstream Service Flow Encodings)
    S01 (Service Flow Reference) = 17
    S06 (QoS Parameter Set Type) = 7
25 (Downstream Service Flow Encodings)
    S01 (Service Flow Reference) = 18
    S06 (QoS Parameter Set Type) = 7
23 (Downstream Packet Classification Encoding Block)

```

```

S01 (Classifier Reference)          = 19
S03 (Service Flow Reference)       = 19
S09 (IP Packet Encodings)
  T01 (IP Type of Srv Rng & Mask) = 00 ff ff
S43 (Vendor Specific Options)
  T08 (Vendor ID)                  = 00 00 0c
  T004 (Unknown sub-type)          = 00 00 00 01 00 00 00 01
  T005 (Unknown sub-type)          = 2b 09 08 03 00 00 0c 23 02 00 00
23 (Downstream Packet Classification Encoding Block)
S01 (Classifier Reference)          = 15
S03 (Service Flow Reference)       = 15
S05 (Rule Priority)                 = 3
S09 (IP Packet Encodings)
  T01 (IP Type of Srv Rng & Mask) = 00 ff ff
S43 (Vendor Specific Options)
  T08 (Vendor ID)                  = 00 00 0c
  T004 (Unknown sub-type)          = 00 00 00 01 00 00 00 01
  T005 (Unknown sub-type)          = 2b 09 08 03 00 00 0c 23 02 04 04
23 (Downstream Packet Classification Encoding Block)
S01 (Classifier Reference)          = 16
S03 (Service Flow Reference)       = 16
S05 (Rule Priority)                 = 3
S09 (IP Packet Encodings)
  T01 (IP Type of Srv Rng & Mask) = 00 ff ff
S43 (Vendor Specific Options)
  T08 (Vendor ID)                  = 00 00 0c
  T004 (Unknown sub-type)          = 00 00 00 01 00 00 00 01
  T005 (Unknown sub-type)          = 2b 09 08 03 00 00 0c 23 02 05 05
23 (Downstream Packet Classification Encoding Block)
S01 (Classifier Reference)          = 17
S03 (Service Flow Reference)       = 17
S05 (Rule Priority)                 = 3
S09 (IP Packet Encodings)
  T01 (IP Type of Srv Rng & Mask) = 00 ff ff
S43 (Vendor Specific Options)
  T08 (Vendor ID)                  = 00 00 0c
  T004 (Unknown sub-type)          = 00 00 00 01 00 00 00 01
  T005 (Unknown sub-type)          = 2b 09 08 03 00 00 0c 23 02 06 06
23 (Downstream Packet Classification Encoding Block)
S01 (Classifier Reference)          = 18
S03 (Service Flow Reference)       = 18
S09 (IP Packet Encodings)
  T01 (IP Type of Srv Rng & Mask) = 00 ff ff
S43 (Vendor Specific Options)
  T08 (Vendor ID)                  = 00 00 0c
  T004 (Unknown sub-type)          = 00 00 00 01 00 00 00 01
  T005 (Unknown sub-type)          = 2b 09 08 03 00 00 0c 23 02 07 07
25 (Downstream Service Flow Encodings)
S01 (Service Flow Reference)       = 19
S06 (QoS Parameter Set Type)      = 7
#<EOF>

```

## Additional References

### Technical Assistance

| Description                                                                                                                                                                                                                                                                                                                                                                                                                                                                                                                                                             | Link                                                                    |
|-------------------------------------------------------------------------------------------------------------------------------------------------------------------------------------------------------------------------------------------------------------------------------------------------------------------------------------------------------------------------------------------------------------------------------------------------------------------------------------------------------------------------------------------------------------------------|-------------------------------------------------------------------------|
| <p>The Cisco Support website provides extensive online resources, including documentation and tools for troubleshooting and resolving technical issues with Cisco products and technologies.</p> <p>To receive security and technical information about your products, you can subscribe to various services, such as the Product Alert Tool (accessed from Field Notices), the Cisco Technical Services Newsletter, and Really Simple Syndication (RSS) Feeds.</p> <p>Access to most tools on the Cisco Support website requires a Cisco.com user ID and password.</p> | <a href="http://www.cisco.com/support">http://www.cisco.com/support</a> |

## Feature Information for MPLS QoS via TLV for non-L2VPN Service Flow

Use Cisco Feature Navigator to find information about the platform support and software image support. Cisco Feature Navigator enables you to determine which software images support a specific software release, feature set, or platform. To access Cisco Feature Navigator, go to the <https://cfngn.cisco.com/> link. An account on the Cisco.com page is not required.



**Note** The following table lists the software release in which a given feature is introduced. Unless noted otherwise, subsequent releases of that software release train also support that feature.

**Table 216: Feature Information for MPLS QoS via TLV for non-L2VPN Service Flow**

| Feature Name                                | Releases                    | Feature Information                                                                                               |
|---------------------------------------------|-----------------------------|-------------------------------------------------------------------------------------------------------------------|
| MPLS QoS via TLV for non-L2VPN Service Flow | Cisco IOS XE Everest 16.6.1 | This feature was integrated into Cisco IOS XE Everest 16.6.1 on the Cisco cBR Series Converged Broadband Routers. |
| MPLS QoS via TLV for non-L2VPN Service Flow | Cisco IOS XE Everest 16.6.1 | This feature was integrated into Cisco IOS XE Everest 16.6.1 on the Cisco cBR Series Converged Broadband Routers. |



## CHAPTER 59

# IPsec Security Support

---

IPsec is a security framework of open standards developed by the IETF. IPsec enables security for information that is sent over unprotected networks. IPsec acts at the network layer, protecting and authenticating IP packets between participating IPsec devices (“peers”), such as Cisco routers.

- [Finding Feature Information, on page 987](#)
- [Hardware Compatibility Matrix for the Cisco cBR Series Routers, on page 987](#)
- [IPsec Security Support, on page 989](#)
- [IPsec Security Limitations, on page 989](#)
- [Configuring IPsec Security, on page 989](#)
- [Configuring Transform Sets for IKEv2, on page 991](#)
- [Feature Information for IPsec Security Support, on page 992](#)

## Finding Feature Information

Your software release may not support all the features that are documented in this module. For the latest feature information and caveats, see the release notes for your platform and software release. The Feature Information Table at the end of this document provides information about the documented features and lists the releases in which each feature is supported.

Use Cisco Feature Navigator to find information about platform support and Cisco software image support. To access Cisco Feature Navigator, go to <http://tools.cisco.com/ITDIT/CFN/>. An account on <http://www.cisco.com/> is not required.

## Hardware Compatibility Matrix for the Cisco cBR Series Routers



---

**Note** The hardware components that are introduced in a given Cisco IOS-XE Release are supported in all subsequent releases unless otherwise specified.

---

Table 217: Hardware Compatibility Matrix for the Cisco cBR Series Routers

| Cisco CMTS Platform                    | Processor Engine                                                                                                                                                                                  | Interface Cards                                                                                                                                                                                                                                                                                                                                                                                                                                                                                                                                                                                                                                                                                                                                                                                 |
|----------------------------------------|---------------------------------------------------------------------------------------------------------------------------------------------------------------------------------------------------|-------------------------------------------------------------------------------------------------------------------------------------------------------------------------------------------------------------------------------------------------------------------------------------------------------------------------------------------------------------------------------------------------------------------------------------------------------------------------------------------------------------------------------------------------------------------------------------------------------------------------------------------------------------------------------------------------------------------------------------------------------------------------------------------------|
| Cisco cBR-8 Converged Broadband Router | <p><b>Cisco IOS-XE Release 16.5.1 and Later Releases</b></p> <p>Cisco cBR-8 Supervisor:</p> <ul style="list-style-type: none"> <li>• PID—CBR-SUP-250G</li> <li>• PID—CBR-CCAP-SUP-160G</li> </ul> | <p><b>Cisco IOS-XE Release 16.5.1 and Later Releases</b></p> <p>Cisco cBR-8 CCAP Line Cards:</p> <ul style="list-style-type: none"> <li>• PID—CBR-LC-8D30-16U30</li> <li>• PID—CBR-LC-8D31-16U30</li> <li>• PID—CBR-RF-PIC</li> <li>• PID—CBR-RF-PROT-PIC</li> <li>• PID—CBR-CCAP-LC-40G</li> <li>• PID—CBR-CCAP-LC-40G-R</li> <li>• PID—CBR-CCAP-LC-G2-R</li> <li>• PID—CBR-SUP-8X10G-PIC</li> <li>• PID—CBR-2X100G-PIC</li> </ul> <p>Digital PICs:</p> <ul style="list-style-type: none"> <li>• PID—CBR-DPIC-8X10G</li> <li>• PID—CBR-DPIC-2X100G</li> </ul> <p>Cisco cBR-8 Downstream PHY Module:</p> <ul style="list-style-type: none"> <li>• PID—CBR-D31-DS-MOD</li> </ul> <p>Cisco cBR-8 Upstream PHY Modules:</p> <ul style="list-style-type: none"> <li>• PID—CBR-D31-US-MOD</li> </ul> |



**Note** Do not use DPICs (8X10G and 2x100G) to forward IP traffic, as it may cause buffer exhaustion, leading to line card reload.

The only allowed traffic on a DPIC interface is DEPI, UEPI, and GCP traffic from the Cisco cBR-8 router to Remote PHY devices. Other traffic such as DHCP, SSH, and UTSC should flow via another router, since DPICs cannot be used for normal routing.



# IPsec Security Support

Cisco IOS XE Amsterdam 17.2.x provides limited support for up to 16 Gbps encrypted IPsec that is sent or forwarded by cBR8.

IPsec is a security framework of open standards developed by the IETF. IPsec enables security for information that is sent over unprotected networks. IPsec acts at the network layer, protecting and authenticating IP packets between participating IPsec devices (“peers”), such as Cisco routers.

IPsec is mainly for securing lawful intercept (LI) traffic from cBR8 to MAC Domain profile. The IPsec feature now supports:

- AES-CBC-128 encryption
- HMAC-SHA-256 authentication
- ESP tunnel mode
- IKEv2 with certificate or preshared key
- PFS (Perfect Forward Secrecy)

## IPsec Security Limitations

The IPsec feature for Cisco IOS XE Amsterdam 17.2.1 has the following limitations:

- Only supported on SUP 160.
- The RX path of IPsec tunnel only supports minimum control traffic. The traffic is punted to IOSd, and is heavily rate-limited. The default limit is 200 packets/second (configurable).

## Configuring IPsec Security

To configure the IPsec security, complete the following steps:

1. Use the **crypto ipsec transform-set <ts-name> esp-aes esp-sha256-hmac** command. However, note that only the following options are supported:
  - Support for **esp-aes esp-sha256-hmac**
  - Support for *mode tunnel*

You can optionally use **set pfs <dh-group-name>** to enable perfect forward secrecy in IPsec profile.

2. Use the **crypto ipsec profile <profile-name>**, where the IKEv2 profile is set into IPsec profile.
3. Use the **tunnel protection ipsec profile** tunnel interface.

To view your IPsec information, use the **show crypto ipsec sa detail** command:

```
Router# show crypto ipsec sa detail
Load for five secs: 3%/0%; one minute: 8%; five minutes: 4%
```

Time source is NTP, 12:40:49.195 EDT Wed Feb 26 2020

```

interface: Tunnel101
  Crypto map tag: Tunnel101-head-0, local addr 102.0.0.2

protected vrf: (none)
local ident (addr/mask/prot/port): (102.0.0.2/255.255.255.255/47/0)
remote ident (addr/mask/prot/port): (102.0.0.1/255.255.255.255/47/0)
current_peer 102.0.0.1 port 500
  PERMIT, flags={origin_is_acl,}
  #pkts encaps: 0, #pkts encrypt: 0, #pkts digest: 0
  #pkts decaps: 0, #pkts decrypt: 0, #pkts verify: 0
  #pkts compressed: 0, #pkts decompressed: 0
  #pkts not compressed: 0, #pkts compr. failed: 0
  #pkts not decompressed: 0, #pkts decompress failed: 0
  #pkts no sa (send) 0, #pkts invalid sa (rcv) 0
  #pkts encaps failed (send) 0, #pkts decaps failed (rcv) 0
  #pkts invalid prot (rcv) 0, #pkts verify failed: 0
  #pkts invalid identity (rcv) 0, #pkts invalid len (rcv) 0
  #pkts replay rollover (send): 0, #pkts replay rollover (rcv) 0
  ##pkts replay failed (rcv): 0
  #pkts tagged (send): 0, #pkts untagged (rcv): 0
  #pkts not tagged (send): 0, #pkts not untagged (rcv): 0
  #pkts internal err (send): 0, #pkts internal err (rcv) 0

local crypto endpt.: 102.0.0.2, remote crypto endpt.: 102.0.0.1
plaintext mtu 1438, path mtu 1500, ip mtu 1500, ip mtu idb TenGigabitEthernet4/1/0
current outbound spi: 0xBD3A2CBF(3174706367)
PFS (Y/N): N, DH group: none

inbound esp sas:
  spi: 0xC67787E8(3329722344)
  transform: esp-aes esp-sha256-hmac ,
  in use settings =(Tunnel, )
  conn id: 2, flow_id: SW:2, sibling_flags FFFFFFFF80000040, crypto map:
Tunnel101-head-0
  sa timing: remaining key lifetime (k/sec): (4242079/86293)
  IV size: 16 bytes
  replay detection support: Y
  Status: ACTIVE(ACTIVE)

inbound ah sas:

inbound pcp sas:

outbound esp sas:
  spi: 0xBD3A2CBF(3174706367)
  transform: esp-aes esp-sha256-hmac ,
  in use settings =(Tunnel, )
  conn id: 1, flow_id: SW:1, sibling_flags FFFFFFFF80000040, crypto map:
Tunnel101-head-0
  sa timing: remaining key lifetime (k/sec): (4242079/86293)
  IV size: 16 bytes
  replay detection support: Y
  Status: ACTIVE(ACTIVE)

outbound ah sas:

outbound pcp sas:

```

## Configuring Transform Sets for IKEv2

You can choose to configure the IKEv2 using either of the following options:

- IKEv2 with pre-shared key. This includes the following options:
  - **crypto ikev2 proposal <proposal-name>**.
  - **crypto ikev2 policy <policy-name>**
  - **crypto ikev2 keyring <keyring-name>**

Set keyring in IKEv2 profile. A configuration example using IKEv2 with pre-shared key is as shown:

```
crypto ikev2 proposal li-ikev2-proposal
  encryption aes-cbc-128
  integrity sha256
  group 5 2
crypto ikev2 policy li-ikev2-policy
  match address local 102.0.0.2
  proposal li-ikev2-proposal
crypto ikev2 keyring li-kyr
  peer li-peer
  address 102.0.0.1 255.255.255.0
  identity address 102.0.0.2
  pre-shared-key key1
!
crypto ikev2 profile li-profile
  match address local interface TenGigabitEthernet4/1/7
  match identity remote address 102.0.0.1 255.255.255.255
  authentication remote pre-share
  authentication local pre-share key key1
  keyring local li-kyr
crypto ipsec transform-set TS esp-aes esp-sha256-hmac
  mode tunnel
crypto ipsec profile li-ipsec-gre
  set security-association lifetime seconds 86400
  set transform-set TS
  set pfs group14
  set ikev2-profile li-profile
```

- IKEv2 with certificate authority. This includes the following steps:
  1. Generate the RSA key pair.
  2. Configure the PKI trustpoint. This requires the CA server supporting SCEP (Simple Certificate Enrollment Protocol).  
  
Configure **crypto pki trustpoint** to enroll to CA. Note that the *subject-name* will be used for authentication in the example
  3. Set the certificate map in IKEv2 profile by configuring **crypto pki certificate map <map-name> <id>** to match the certificate content.
  4. Enroll the certificate.

To view your IPsec information, use the **show crypto ikev2 sa detail** command:

```

Router# show crypto ikev2 sa detail
Load for five secs: 3%/0%; one minute: 8%; five minutes: 4%
Time source is NTP, 12:40:57.672 EDT Wed Feb 26 2020

IPv4 Crypto IKEv2 SA

Tunnel-id Local Remote fvr/ivrf Status
1 102.0.0.2/500 102.0.0.1/500 none/none READY
Encr: AES-CBC, keysize: 128, PRF: SHA256, Hash: SHA256, DH Grp:5, Auth sign: RSA,
Auth verify: RSA
Life/Active Time: 86400/115 sec
CE id: 1001, Session-id: 1
Status Description: Negotiation done
Local spi: A3C274EBBD7FFF2F Remote spi: AA160367FFD29C2D
Local id: hostname=tb34-cBR8.cisco.com,cn=ANSSI Test CBR8
Remote id: hostname=cMCTS-bcl-ASR1K6-2,cn=ANSSI Test ASR1K
Local req msg id: 2 Remote req msg id: 0
Local next msg id: 2 Remote next msg id: 0
Local req queued: 2 Remote req queued: 0
Local window: 5 Remote window: 5
DPD configured for 0 seconds, retry 0
Fragmentation not configured.
Dynamic Route Update: enabled
Extended Authentication not configured.
NAT-T is not detected
Cisco Trust Security SGT is disabled
Initiator of SA : Yes

IPv6 Crypto IKEv2 SA

```



**Note** The IPsec and IKEv2 are configured in the same way as ASR 1000. Go through the [ASR 1000 Internet Key Exchange for IPsec VPNs Configuration Guide](#) for more information. The following limitations apply:

- Supported encryption
- Authentication algorithms
- ESP tunnel mode

## Feature Information for IPsec Security Support

Use Cisco Feature Navigator to find information about the platform support and software image support. Cisco Feature Navigator enables you to determine which software images support a specific software release, feature set, or platform. To access Cisco Feature Navigator, go to the <https://cfnng.cisco.com/> link. An account on the Cisco.com page is not required.



**Note** The following table lists the software release in which a given feature is introduced. Unless noted otherwise, subsequent releases of that software release train also support that feature.

*Table 218: Feature Information for IPsec Security Support*

| <b>Feature Name</b>    | <b>Releases</b>               | <b>Feature Information</b>                                                                                          |
|------------------------|-------------------------------|---------------------------------------------------------------------------------------------------------------------|
| IPsec Security Support | Cisco IOS XE Amsterdam 17.2.1 | This feature was integrated into Cisco IOS XE Amsterdam 17.2.1 on the Cisco cBR Series Converged Broadband Routers. |





## PART VII

### Layer 3 Configuration

- [DHCP, ToD, and TFTP Services for CMTS Routers, on page 997](#)
- [Virtual Interface Bundling, on page 1017](#)
- [IPv6 on Cable, on page 1027](#)
- [Cable DHCP Leasequery, on page 1071](#)
- [DHCPv6 Bulk-Lease query, on page 1081](#)
- [Layer 3 CPE Mobility, on page 1085](#)
- [DOCSIS 3.0 Multicast Support, on page 1095](#)
- [IPv6 Segment Routing on Cisco cBR, on page 1121](#)







## CHAPTER 60

# DHCP, ToD, and TFTP Services for CMTS Routers

This document describes how to configure Cisco Cable Modem Termination System (CMTS) platforms so that they support onboard servers that provide Dynamic Host Configuration Protocol (DHCP), Time-of-Day (ToD), and Trivial File Transfer Protocol (TFTP) services for use in Data-over-Cable Service Interface Specification (DOCSIS) networks. In addition, this document provides information about optional configurations that can be used with external DHCP servers.

- [Prerequisites for DHCP, ToD, and TFTP Services, on page 997](#)
- [Restrictions for DHCP, ToD, and TFTP Services, on page 997](#)
- [Information About DHCP, ToD, and TFTP Services, on page 998](#)
- [How to Configure ToD, and TFTP Services, on page 1003](#)
- [How to Configure ToD, and TFTP Services, on page 1014](#)
- [Configuration Examples, on page 1014](#)
- [Additional References, on page 1015](#)
- [Feature Information for the DHCP, ToD, and TFTP Services for the CMTS Routers, on page 1015](#)

## Prerequisites for DHCP, ToD, and TFTP Services

To use the Cisco CMTS as the ToD server, either standalone or with other external ToD servers, you must configure the DHCP server to provide the IP address of the Cisco CMTS as one of the valid ToD servers (DHCP option 4) for cable modems.

## Restrictions for DHCP, ToD, and TFTP Services

- The ToD server must use the UDP protocol to conform to DOCSIS specifications.
- For proper operation of the DOCSIS network, especially a DOCSIS 1.1 network using BPI+ encryption and authentication, the system clock on the Cisco CMTS must be set accurately. You can achieve this by manually using the **set clock** command, or by configuring the CMTS to use either the Network Time Protocol (NTP) or the Simple Network Time Protocol (SNTP).
- Cisco cBR series routers do not support internal DHCP servers.

# Information About DHCP, ToD, and TFTP Services

This section provides the following information about the DHCP, ToD, and TFTP Services feature, and its individual components:

## Feature Overview

All Cisco CMTS platforms support onboard servers that provide DHCP, ToD, and TFTP proxy-services for use in DOCSIS cable networks. These servers provide the registration services needed by DOCSIS 1.0- and 1.1-compliant cable modems:

- **External DHCP Servers**—Provides DHCP services. External DHCP servers are usually part of an integrated provisioning system that is more suitable when managing large cable networks.
- **Time-of-DayServer\_**—Provides an [RFC 868](#) -compliant ToD service so that cable modems can obtain the current date and time during the registration process. The cable modem connects with the ToD server after it has obtained its IP address and other DHCP-provided IP parameters.

Although cable modems do not need to successfully complete the ToD request before coming online, this allows them to add accurate timestamps to their event logs so that these logs are coordinated to the clock used on the CMTS. In addition, having the accurate date and time is essential if the cable modem is trying to register with Baseline Privacy Interface Plus (BPI+) encryption and authentication.

- **External TFTP\_Server**—Downloads the DOCSIS configuration file to the cable modem. The DOCSIS configuration file contains the operational parameters for the cable modem. The cable modem downloads its DOCSIS configuration file after connecting with the ToD server.



---

**Note** You can add additional servers in a number of ways. For example, most cable operators use Cisco Network Registrar (CNR) to provide the DHCP and TFTP servers. ToD servers are freely available for most workstations and PCs. You can install the additional servers on one workstation or PC or on different workstations and PCs.

---

## External DHCP Servers

The Cisco CMTS router provides the following optional configurations that can enhance the operation and security of external DHCP servers that you are using on the DOCSIS cable network:

### Cable Source Verify Feature

To combat theft-of-service attacks, you can enable the **cable source-verify** command on the cable interfaces on the Cisco CMTS router. This feature uses the router's internal database to verify the validity of the IP packets that the CMTS receives on the cable interfaces, and provides three levels of protection:

- At the most basic level of protection, the Cable Source Verify feature examines every IP upstream packet to prevent duplicate IP addresses from appearing on the cable network. If a conflict occurs, the Cisco CMTS recognizes only packets coming from the device that was assigned the IP address by the DHCP server. The devices with the duplicate addresses are not allowed network address. The CMTS also refuses to recognize traffic from devices with IP addresses that have network addresses that are unauthorized for that particular cable segment.

- Adding the **dhcp** option to the **cable source-verify** command provides a more comprehensive level of protection by preventing users from statically assigning currently-unused IP addresses to their devices. When the Cisco CMTS receives a packet with an unknown IP address on a cable interface, the CMTS drops the packet but also issues a DHCP LEASEQUERY message that queries the DHCP servers for any information about the IP and MAC addresses of that device. If the DHCP servers do not return any information about the device, the CMTS continues to block the network access for that device.
- When you use the **dhcp** option, you can also enable the **leasetimer** option, which instructs the Cisco CMTS to periodically check its internal CPE database for IP addresses whose lease times have expired. The CPE devices that are using expired IP addresses are denied further access to the network until they renew their IP addresses from a valid DHCP server. This can prevent users from taking DHCP-assigned IP addresses and assigning them as static addresses to their CPE devices.
- In addition to the **dhcp** option, you can also configure prefix-based source address verification (SAV) on the Cisco CMTS using the **cable source-verify** group command. A CM may have a static IPv4 or IPv6 prefix configured, which belongs to an SAV group. When the SAV prefix processing is enabled on the Cisco CMTS, the source IP address of the packets coming from the CM is matched against the configured prefix and SAV group (for that CM) for verification. If the verification fails, the packets are dropped, else the packets are forwarded for further processing. For more information on SAV prefix processing and SAV prefix configuration, see [Prefix-based Source Address Verification , on page 999](#) and [Configuring Prefix-based Source Address Verification, on page 1010](#)

## Prefix-based Source Address Verification

The Source Address Verification (SAV) feature verifies the source IP address of an upstream packet to ensure that the SID/MAC and IP are consistent. The DOCSIS 3.0 Security Specification introduces prefix-based SAV where every CM may have static IPv4 or IPv6 prefixes configured. These prefixes are either preconfigured on the CMTS, or are communicated to the CMTS during CM registration. The Cisco CMTS uses these configured prefixes to verify the source IP address of all the incoming packets from that CM.

An SAV group is a collection of prefixes. A prefix is an IPv4 or IPv6 subnet address. You can use the **cable source-verify group** command in global configuration mode to configure SAV groups. A total of 255 SAV groups are supported on a CMTS, with each SAV group having a maximum of four prefixes. Prefixes can be configured using the **prefix** command.

During registration, CMs communicate their configured static prefixes to the CMTS using two TLVs, 43.7.1 and 43.7.2. The TLV 43.7.1 specifies the SAV prefix group name that the CM belongs to, and TLV 43.7.2 specifies the actual IPv4 or IPv6 prefix. Each CM can have a maximum of four prefixes configured. When the Cisco CMTS receives these TLVs, it first identifies if the specified SAV group and the prefixes are already configured on the Cisco CMTS. If they are configured, the Cisco CMTS associates them to the registering CM. However if they are not configured, the Cisco CMTS automatically creates the specified SAV group and prefixes before associating them to the registering CM.

The SAV group name and the prefixes that are provided by these TLVs are considered valid by the Cisco CMTS. The packets received (from the CM) with the source IP address belonging to the prefix specified by the TLV are considered authorized. For example, if a given CM has been configured with an SAV prefix of 10.10.10.0/24, then any packet received from this CM (or CPE behind the CM) that is sourced with this address in the subnet 10.10.10.0/24 is considered to be authorized.

For more information on how to configure SAV groups and prefixes see [Configuring Prefix-based Source Address Verification, on page 1010](#).

## Smart Relay Feature

The Cisco CMTS supports a Smart Relay feature (the **ip dhcp smart-relay** command), which automatically switches a cable modem or CPE device to secondary DHCP servers or address pools if the primary server

runs out of IP addresses or otherwise fails to respond with an IP address. The relay agent attempts to forward DHCP requests to the primary server three times. After three attempts with no successful response from the primary, the relay agent automatically switches to the secondary server.

When you are using the **cable dhcp-giaddr policy** command to specify that the CPE devices should use the secondary DHCP pools corresponding to the secondary addresses on a cable interface, the smart relay agent automatically rotates through the available secondary in a round robin fashion until an available pool of addresses is found. This ensures that clients are not locked out of the network because a particular pool has been exhausted.

## GIADDR Field

When using separate IP address pools for cable modems and CPE devices, you can use the **cable dhcp-giaddr policy** command to specify that cable modems should use an address from the primary pool and that CPE devices should use addresses from the secondary pool. The default is for the CMTS to send all DHCP requests to the primary DHCP server, while the secondary servers are used only if the primary server does not respond. The different DHCP servers are specified using the **cable helper** commands.

## DHCP Relay Agent Sub-option

The DHCP Relay Agent Information sub-option (DHCP Option 82, Suboption 9) enhancement simplifies provisioning of the CPE devices. Using this sub-option, the cable operators can relay the service class or QoS information of the CPE to the DHCP server to get an appropriate IP address.

To provision a CPE, the DHCP server should be made aware of the service class or QoS information of the CPE. The DHCP server obtains this information using the DHCP DISCOVER message, which includes the service class or QoS information of the CM behind which the CPE resides.

During the provisioning process, the Cisco CMTS uses the DHCPv4 Relay Agent Information sub-option to advertise information about the service class or QoS profile of the CMs to the DHCP server. Using the same technique, the CPE information is relayed to the DHCP server to get an appropriate IP address.

To enable the service classes option, the service class name specified in the CM configuration file must be configured on the Cisco CMTS. This is done by using the **cable dhcp-insert service-class** command.



---

**Note** To insert service class relay agent information option into the DHCP DISCOVER messages, the **ip dhcp relay information option-insert** command must be configured on the bundle interface.

---

## Time-of-Day Server

The Cisco CMTS can function as a ToD server that provides the current date and time to the cable modems and other customer premises equipment (CPE) devices connected to its cable interfaces. This allows the cable modems and CPE devices to accurately timestamp their Simple Network Management Protocol (SNMP) messages and error log entries, as well as ensure that all of the system clocks on the cable network are synchronized to the same system time.

The DOCSIS 1.0 and 1.1 specifications require that all DOCSIS cable modems request the following time-related fields in the DHCP request they send during their initial power-on provisioning:

- Time Offset (option 2)—Specifies the time zone for the cable modem or CPE device, in the form of the number of seconds that the device's timestamp is offset from Greenwich Mean Time (GMT).

- Time Server Option (option 4)—Specifies one or more IP addresses for a ToD server.

After a cable modem successfully acquires a DHCP lease time, it then attempts to contact one of the ToD servers provided in the list provided by the DHCP server. If successful, the cable modem updates its system clock with the time offset and timestamp received from the ToD server.

If a ToD server cannot be reached or if it does not respond, the cable modem eventually times out, logs the failure with the CMTS, and continues on with the initialization process. The cable modem can come online without receiving a reply from a ToD server, but it must periodically continue to reach the ToD server at least once in every five-minute period until it successfully receives a ToD reply. Until it reaches a ToD server, the cable modem must initialize its system clock to midnight on January 1, 1970 GMT.



---

**Note** Initial versions of the DOCSIS 1.0 specification specified that the cable device must obtain a valid response from a ToD server before continuing with the initialization process. This requirement was removed in the released DOCSIS 1.0 specification and in the DOCSIS 1.1 specifications. Cable devices running older firmware that is compliant with the initial DOCSIS 1.0 specification, however, might require receiving a reply from a ToD server before being able to come online.

---

Because cable modems will repeatedly retry connecting with a ToD server until they receive a successful reply, you should consider activating the ToD server on the Cisco CMTS, even if you have one or more other ToD servers at the headend. This ensures that an online cable modem will always be able to connect with the ToD server on the Cisco CMTS, even if the other servers go down or are unreachable because of network congestion, and therefore will not send repeated ToD requests.



---

**Tip** To be able to use the Cisco CMTS as the ToD server, you must configure the DHCP server to provide the IP address Cisco CMTS as one of the valid ToD servers (DHCP option 4) for cable modems.

---

In addition, although the DOCSIS specifications do not require that a cable modem successfully obtain a response from a ToD server before coming online, not obtaining a timestamp could prevent the cable modem from coming online in the following situations:

- If DOCSIS configuration files are being timestamped, to prevent cable modems from caching the files and replaying them, the clocks on the cable modem and CMTS must be synchronized. Otherwise, the cable modem cannot determine whether a DOCSIS configuration file has the proper timestamp.
- If cable modems register using Baseline Privacy Interface Plus (BPI+) authentication and encryption, the clocks on the cable modem and CMTS must be synchronized. This is because BPI+ authorization requires that the CMTS and cable modem verify the timestamps on the digital certificates being used for authentication. If the timestamps on the CMTS and cable modem are not synchronized, the cable modem cannot come online using BPI+ encryption.



---

**Note** DOCSIS cable modems must use [RFC 868](#) -compliant ToD server to obtain the current system time. They cannot use the Network Time Protocol (NTP) or Simple Network Time Protocol (SNTP) service for this purpose. However, the Cisco CMTS can use an NTP or SNTP server to set its own system clock, which can then be used by the ToD server. Otherwise, you must manually set the clock on the CMTS using the **clock set** command each time that the CMTS boots up.

---



**Tip** Additional servers can be provided by workstations or PCs installed at the cable headend. UNIX and Solaris systems typically include a ToD server as part of the operating system, which can be enabled by putting the appropriate line in the `inetd.conf` file. Windows systems can use shareware servers such as Greyware and Tardis. The DOCSIS specifications require that the ToD servers use the User Datagram Protocol (UDP) protocol instead of the TCP protocol for its packets.

## TFTP Server

All Cisco CMTS platforms can be configured to provide a TFTP server that can provide the following types of files to DOCSIS cable modems:

- **DOCSIS Configuration File**—After a DOCSIS cable modem has acquired a DHCP lease and attempted to contact a ToD server, the cable modem uses TFTP to download a DOCSIS configuration file from an authorized TFTP server. The DHCP server is responsible for providing the name of the DOCSIS configuration file and IP address of the TFTP server to the cable modem.
- **Software Upgrade File**—If the DOCSIS configuration file specifies that the cable modem must be running a specific version of software, and the cable modem is not already running that software, the cable modem must download that software file. For security, the cable operator can use different TFTP servers for downloading DOCSIS configuration files and for downloading new software files.
- **Cisco IOS-XE Configuration File**—The DOCSIS configuration file for Cisco cable devices can also specify that the cable modem should download a Cisco IOS-XE configuration file that contains command-line interface (CLI) configuration commands. Typically this is done to configure platform-specific features such as voice ports or IPSec encryption.



**Note** Do not confuse the DOCSIS configuration file with the Cisco IOS-XE configuration file. The DOCSIS configuration file is a binary file in the particular format that is specified by the DOCSIS specifications, and each DOCSIS cable modem must download a valid file before coming online. In contrast, the Cisco IOS-XE configuration file is an ASCII text file that contains one or more Cisco IOS-XE CLI configuration commands. Only Cisco cable devices can download a Cisco IOS-XE file.

All Cisco CMTS platforms can be configured as TFTP servers that can upload these files to the cable modem. The files can reside on any valid device but typically should be copied to the Flash memory device inserted into the Flash disk slot on the Cisco CMTS.

## Sniff out boot file name from DHCP process per CM

Starting from Cisco IOS XE Gibraltar 16.12.1, the cBR-8 can sniff, parse and save the configuration file related information per CM. This includes path and name of the configuration file, the IPv4 or IPv6 address of the TFTP server from which the CM requests the configuration file, and the timestamp when cBR-8 sniffed the CM's TFTP RRQ packet that requests the configuration file. This feature is enabled by default and cannot be disabled.

The **show cable modem tftp** command displays a single CM's configuration file related information.

The following example shows the sample output for this command.

```
Router#show cable modem 34bd.fa0f.4418 tftp
Host Interface : C1/0/0
```

```

MAC Address : 34bd.fa0f.4418
IP Address : 50.13.0.4
IPv6 Address : 2001:50:13:0:74E3:4197:E2F2:8162
Modem Status : w-online(pt)
TFTP Server Address : 2001:1:38::25:3
Modem Configuration File Name : cbr8/cm.bin
Timestamp : 02:16:02 CST Tue May 21 2019

```

## Benefits

- The Cisco CMTS can act as a primary or backup ToD server to ensure that all cable modems are synchronized with the proper date and time before coming online. This also enables cable modems to come online more quickly because they will not have to wait for the ToD timeout period before coming online.
- The ToD server on the Cisco CMTS ensures that all devices connected to the cable network are using the same system clock, making it easier for you to troubleshoot system problems when you analyze the debugging output and error logs generated by many cable modems, CPE devices, the Cisco CMTS, and other services.
- The Cisco CMTS can act as a TFTP server for DOCSIS configuration files, software upgrade files, and Cisco IOS configuration files.

## How to Configure ToD, and TFTP Services

See the following configuration tasks required to configure time-of-day service, and TFTP service on a Cisco CMTS:

### Configuring Time-of-Day Service

This section provides procedures for enabling and disabling the time-of-day (ToD) server on the Cisco CMTS routers.

#### Prerequisites

To be able to use the Cisco CMTS as the ToD server you must configure the DHCP server to provide the IP address Cisco CMTS as one of the valid ToD servers (DHCP option 4) for cable modems.

### Enabling Time-of-Day Service

To enable the ToD server on a Cisco CMTS, use the following procedure, beginning in EXEC mode.

#### Procedure

|        | Command or Action                                                                | Purpose                                                        |
|--------|----------------------------------------------------------------------------------|----------------------------------------------------------------|
| Step 1 | <p><b>enable</b></p> <p><b>Example:</b></p> <pre>Router&gt; enable Router#</pre> | Enables privileged EXEC mode. Enter your password if prompted. |

|               | Command or Action                                                                                                                                                                  | Purpose                                                                                                                                                                                                                                                                                                                                                                       |
|---------------|------------------------------------------------------------------------------------------------------------------------------------------------------------------------------------|-------------------------------------------------------------------------------------------------------------------------------------------------------------------------------------------------------------------------------------------------------------------------------------------------------------------------------------------------------------------------------|
| <b>Step 2</b> | <b>configure terminal</b><br><b>Example:</b><br><br>Router# <b>configure terminal</b><br>Router(config)#                                                                           | Enters global configuration mode.                                                                                                                                                                                                                                                                                                                                             |
| <b>Step 3</b> | <b>service udp-small-servers max-servers no-limit</b><br><b>Example:</b><br><br>Router(config)# <b>service udp-small-servers</b><br><b>max-servers no-limit</b><br>Router(config)# | Enables use of minor servers that use the UDP protocol (such as ToD, echo, chargen, and discard).<br><br>The max-servers no-limit option allows a large number of cable modems to obtain the ToD server at one time, in the event that a cable or power failure forces many cable modems offline. When the problem has been resolved, the cable modems can quickly reconnect. |
| <b>Step 4</b> | <b>cable time-server</b><br><b>Example:</b><br><br>Router(config)# <b>cable time-server</b><br>Router(config)#                                                                     | Enables the ToD server on the Cisco CMTS.                                                                                                                                                                                                                                                                                                                                     |
| <b>Step 5</b> | <b>exit</b><br><b>Example:</b><br><br>Router(config)# <b>exit</b><br>Router#                                                                                                       | Exits global configuration mode.                                                                                                                                                                                                                                                                                                                                              |

## Disabling Time-of-Day Service

To disable the ToD server, use the following procedure, beginning in EXEC mode.

### Procedure

|               | Command or Action                                                                                        | Purpose                                                        |
|---------------|----------------------------------------------------------------------------------------------------------|----------------------------------------------------------------|
| <b>Step 1</b> | <b>enable</b><br><b>Example:</b><br><br>Router> <b>enable</b><br>Router#                                 | Enables privileged EXEC mode. Enter your password if prompted. |
| <b>Step 2</b> | <b>configure terminal</b><br><b>Example:</b><br><br>Router# <b>configure terminal</b><br>Router(config)# | Enters global configuration mode.                              |
| <b>Step 3</b> | <b>no cable time-server</b><br><b>Example:</b>                                                           | Disables the ToD server on the Cisco CMTS.                     |



|               | Command or Action                                                                                                                    | Purpose                                                                                                                                                                |
|---------------|--------------------------------------------------------------------------------------------------------------------------------------|------------------------------------------------------------------------------------------------------------------------------------------------------------------------|
|               | Router(config)# <b>cable time-server</b><br>Router(config)#                                                                          |                                                                                                                                                                        |
| <b>Step 4</b> | <b>no service udp-small-servers</b><br><b>Example:</b><br><br>Router(config)# <b>no service udp-small-servers</b><br>Router(config)# | (Optional) Disables the use of all minor UDP servers.<br><br><b>Note</b> Do not disable the minor UDP servers if you are also enabling the other DHCP or TFTP servers. |
| <b>Step 5</b> | <b>exit</b><br><b>Example:</b><br><br>Router(config)# <b>exit</b><br>Router#                                                         | Exits global configuration mode.                                                                                                                                       |

## Configuring TFTP Service

To configure TFTP service on a Cisco CMTS where the CMTS can act as a TFTP server and download a DOCSIS configuration file to cable modems, perform the following steps:

- Create the DOCSIS configuration files using the DOCSIS configuration editor of your choice.
- Copy all desired files (DOCSIS configuration files, software upgrade files, and Cisco IOS configuration files) to the Flash memory device on the Cisco CMTS. Typically, this is done by placing the files first on an external TFTP server, and then using TFTP commands to transfer them to the router's Flash memory.
- Enable the TFTP server on the Cisco CMTS with the **tftp-server** command.

Each configuration task is required unless otherwise listed as optional.

### Step 1

Use the **show file systems** command to display the Flash memory cards that are available on your CMTS, along with the free space on each card and the appropriate device names to use to access each card.

Most configurations of the Cisco CMTS platforms support both linear Flash and Flash disk memory cards. Linear Flash memory is accessed using the **slot0** (or **flash**) and **slot1** device names. Flash disk memory is accessed using the **disk0** and **disk1** device names.

For example, the following command shows a Cisco uBR7200 series router that has two linear Flash memory cards installed. The cards can be accessed by the **slot0** (or **flash**) and **slot1** device names.

#### Example:

```
Router# show file systems
```

```
File Systems:
  Size (b)      Free (b)      Type  Flags  Prefixes
  48755200     48747008     flash  rw     slot0: flash:
  16384000     14284000     flash  rw     slot1:
  32768000     31232884     flash  rw     bootflash:
*           -           -       disk  rw     disk0:
           -           -       disk  rw     disk1:
```

```

-          -   opaque      rw   system:
-          -   opaque      rw   null:
-          -   network     rw   tftp:
522232    507263   nvr      rw   nvr:
-          -   network     rw   rc:
-          -   network     rw   ft:
-          -   network     rw   sc:
Router#

```

The following example shows a Cisco uBR10012 router that has two Flash disk cards installed. These cards can be accessed by the **disk0** and **sec-disk0** device names.

#### Example:

```
Router# show file systems
```

```

File Systems:
  Size(b)   Free(b)   Type  Flags  Prefixes
  -         -         flash rw   slot0: flash:
  -         -         flash rw   slot1:
  32768000  29630876 flash rw   bootflash:
* 128094208 95346688  disk  rw   disk0:
  -         -         disk  rw   disk1:
  -         -         opaque rw   system:
  -         -         flash rw   sec-slot0:
  -         -         flash rw   sec-slot1:
* 128094208 95346688  disk  rw   sec-disk0:
  -         -         disk  rw   sec-disk1:
  32768000  29630876 flash rw   sec-bootflash:
  -         -         nvr      rw   sec-nvr:
  -         -         opaque rw   null:
  -         -         network rw   tftp:
  522232    505523   nvr      rw   nvr:
  -         -         network rw   rc:
  -         -         network rw   ft:
  -         -         network rw   sc:
Router#

```

**Step 2** Verify that the desired Flash memory card has sufficient free space for all of the files that you want to copy to the CMTS.

**Step 3** Use the **ping** command to verify that the remote TFTP server that contains the desired files is reachable. For example, the following shows a **ping** command being given to an external TFTP server with the IP address of 10.10.10.1:

#### Example:

```

Router# ping 10.10.10.1
Type escape sequence to abort.
Sending 5, 100-byte ICMP Echos to 10.10.10.1, timeout is 2 seconds:
!!!!
Success rate is 100 percent (5/5), round-trip min/avg/max = 5/6/6 ms

```

**Step 4** Use the **copy tftp devname** command to copy each file from the external TFTP server to the appropriate Flash memory card on the CMTS, where *devname* is the device name for the destination Flash memory card. You will then be prompted for the IP address for the external TFTP server and the filename for the file to be transferred.

The following example shows the file docsis.cm being transferred from the external TFTP server at IP address 10.10.10.1 to the first Flash memory disk (disk0):

#### Example:

```

Router# copy tftp disk0
Address or name of remote host []? 10.10.10.1

```

```

Source filename []? config-files/docsis.cm

Destination filename [docsis.cm]?
Accessing tftp://10.10.10.1/config-file/docsis.cm.....
Loading docsis.cm from 10.10.10.1 (via Ethernet2/0): !!!
[OK - 276/4096 bytes]
276 bytes copied in 0.152 secs
Router#

```

**Step 5** Repeat [Step 4, on page 1006](#) as needed to copy all of the files from the external TFTP server to the Flash memory card on the Cisco CMTS.

**Step 6** Use the **dir** command to verify that the Flash memory card contains all of the transferred files.

**Example:**

```

Router# dir disk0:

Directory of disk0:/
 1 -rw-   10705784   May 30 2002 19:12:46 ubr10k-p6-mz.122-2.8.BC
 2 -rw-         4772   Jun 20 2002 18:12:56  running.cfg.save
 3 -rw-         241   Jul 31 2002 18:25:46  gold.cm
 4 -rw-         225   Jul 31 2002 18:25:46  silver.cm
 5 -rw-         231   Jul 31 2002 18:25:46  bronze.cm
 6 -rw-          74   Oct 11 2002 21:41:14  disable.cm
 7 -rw-   2934028   May 30 2002 11:22:12  ubr924-k8y5-mz.bin
 8 -rw-   3255196   Jun 28 2002 13:53:14  ubr925-k9v9y5-mz.bin
128094208 bytes total (114346688 bytes free)
Router#

```

**Step 7** Use the **configure terminal** command to enter global configuration mode:

**Example:**

```

Router# configure terminal

Router(config)#

```

**Step 8** Use the **tftp-server** command to specify which particular files can be transferred by the TFTP server that is onboard the Cisco CMTS. You can also use the **alias** option to specify a different filename that the DHCP server can use to refer to the file. For example, the following commands enable the TFTP transfer of the configuration files and software upgrade files:

**Example:**

```

Router(config)# tftp-server disk0:gold.cm alias gold.cm

Router(config)# tftp-server disk0:silver.cm alias silver.cm

Router(config)# tftp-server disk0:bronze.cm alias bronze.cm

Router(config)# tftp-server disk0:ubr924-k8y5-mz.bin alias ubr924-codefile

Router(config)# tftp-server disk0:ubr925-k9v9y5-mz.bin alias ubr925-codefile

Router(config)#

```

**Note** The **tftp-server** command also supports the option of specifying an access list that restricts access to the particular file to the IP addresses that match the access list.

**Step 9** (Optional) Use the following command to enable the use of the UDP small servers, and to allow an unlimited number of connections at one time. This will allow a large number of cable modems that have gone offline due to cable or power failure to rapidly come back online.

**Example:**

```
Router(config)# service udp-small-servers max-servers no-limit
```

```
Router(config)#
```

## Optimizing the Use of an External DHCP Server

The Cisco CMTS offers a number of options that can optimize the operation of external DHCP servers on a DOCSIS cable network. See the following sections for details. All procedures are optional, depending on the needs of your network and application servers.

### Configuring Cable Source Verify Option

To enhance security when using external DHCP servers, you can optionally configure the Cable Source Verify feature with the following procedure.



**Restriction**

- The Cable Source Verify feature supports only external DHCP servers. It cannot be used with the internal DHCP server.

**Procedure**

|               | Command or Action                                                                                                          | Purpose                                                                      |
|---------------|----------------------------------------------------------------------------------------------------------------------------|------------------------------------------------------------------------------|
| <b>Step 1</b> | <p><b>enable</b></p> <p><b>Example:</b></p> <pre>Router&gt; enable Router#</pre>                                           | Enables privileged EXEC mode. Enter your password if prompted.               |
| <b>Step 2</b> | <p><b>configure terminal</b></p> <p><b>Example:</b></p> <pre>Router# configure terminal Router(config)#</pre>              | Enters global configuration mode.                                            |
| <b>Step 3</b> | <p><b>interface cable x/y</b></p> <p><b>Example:</b></p> <pre>Router(config)# interface cable 4/0 Router(config-if)#</pre> | Enters cable interface configuration mode for the specified cable interface. |

|        | Command or Action                                                                                                                                                                                                                                                         | Purpose                                                                                                                                                                                                                                                                                                                                                                                                                                                                                                                                                                                                                                                                                                                                                                                                                                                                                                                                                                                                                                                                                                                                                                          |
|--------|---------------------------------------------------------------------------------------------------------------------------------------------------------------------------------------------------------------------------------------------------------------------------|----------------------------------------------------------------------------------------------------------------------------------------------------------------------------------------------------------------------------------------------------------------------------------------------------------------------------------------------------------------------------------------------------------------------------------------------------------------------------------------------------------------------------------------------------------------------------------------------------------------------------------------------------------------------------------------------------------------------------------------------------------------------------------------------------------------------------------------------------------------------------------------------------------------------------------------------------------------------------------------------------------------------------------------------------------------------------------------------------------------------------------------------------------------------------------|
| Step 4 | <p><b>cable source-verify</b> [<b>dhcp</b>   <b>leasetimer</b> <i>value</i> ]</p> <p><b>Example:</b></p> <pre>Router(config-if)# cable source-verify dhcp</pre> <p><b>Example:</b></p> <pre>Router(config-if)# cable source-verify leasetimer 30 Router(config-if)#</pre> | <p>(Optional) Ensures that the CMTS allows network access only to those IP addresses that DHCP servers issued to devices on this cable interface. The CMTS examines DHCP packets that pass through the cable interfaces to build a database of which IP addresses are valid on which interface.</p> <ul style="list-style-type: none"> <li>• <b>dhcp</b> = (Optional) Drops traffic from all devices with unknown IP addresses, but the CMTS also sends a query to the DHCP servers for any information about the device. If a DHCP server informs the CMTS that the device has a valid IP address, the CMTS then allows the device on the network.</li> <li>• <b>leasetimer</b> <i>value</i> = (Optional) Specifies how often, in minutes, the router should check its internal CPE database for IP addresses whose lease times have expired. This can prevent users from taking DHCP-assigned IP addresses and assigning them as static addresses to their CPE devices. The valid range for value is 1 to 240 minutes, with no default.</li> </ul> <p><b>Note</b> The <b>leasetimer</b> option takes effect only when the <b>dhcp</b> option is also used on an interface.</p> |
| Step 5 | <p><b>no cable arp</b></p> <p><b>Example:</b></p> <pre>Router(config-if)# no cable arp Router(config-if)#</pre>                                                                                                                                                           | <p>(Optional) Blocks Address Resolution Protocol (ARP) requests originating from devices on the cable network. Use this command, together with the <b>cable source-verify dhcp</b> command, to block certain types of theft-of-service attacks that attempt to hijack or spoof IP addresses.</p> <p><b>Note</b> Repeat <a href="#">Step 3, on page 1008</a> through <a href="#">Step 5, on page 1009</a> for each desired cable interface.</p>                                                                                                                                                                                                                                                                                                                                                                                                                                                                                                                                                                                                                                                                                                                                   |
| Step 6 | <p><b>exit</b></p> <p><b>Example:</b></p> <pre>Router(config-if)# exit Router(config)#</pre>                                                                                                                                                                              | Exits interface configuration mode.                                                                                                                                                                                                                                                                                                                                                                                                                                                                                                                                                                                                                                                                                                                                                                                                                                                                                                                                                                                                                                                                                                                                              |
| Step 7 | <p><b>ip dhcp relay information option</b></p> <p><b>Example:</b></p> <pre>Router(config)# ip dhcp relay information option Router(config)#</pre>                                                                                                                         | <p>(Optional) Enables the CMTS to insert DHCP relay information (DHCP option 82) in relayed DHCP packets. This allows the DHCP server to store accurate information about which CPE devices are using which cable modems. You should use this command if you are also using the <b>cable source-verify dhcp</b> command.</p>                                                                                                                                                                                                                                                                                                                                                                                                                                                                                                                                                                                                                                                                                                                                                                                                                                                     |
| Step 8 | <p><b>exit</b></p> <p><b>Example:</b></p> <pre>Router(config)# exit Router#</pre>                                                                                                                                                                                         | Exits global configuration mode.                                                                                                                                                                                                                                                                                                                                                                                                                                                                                                                                                                                                                                                                                                                                                                                                                                                                                                                                                                                                                                                                                                                                                 |

## Configuring Prefix-based Source Address Verification

To enhance security when using external DHCP servers, you can configure a prefix-based SAV with the following procedure, beginning in global configuration (config) mode.

### Procedure

|               | Command or Action                                                                                                                                                              | Purpose                                                                                                                                                                                                                                                                                                                                                                                                                                                                                                                                                                                                                                                                                    |
|---------------|--------------------------------------------------------------------------------------------------------------------------------------------------------------------------------|--------------------------------------------------------------------------------------------------------------------------------------------------------------------------------------------------------------------------------------------------------------------------------------------------------------------------------------------------------------------------------------------------------------------------------------------------------------------------------------------------------------------------------------------------------------------------------------------------------------------------------------------------------------------------------------------|
| <b>Step 1</b> | <b>enable</b><br><b>Example:</b><br><pre>Router&gt; enable Router#</pre>                                                                                                       | Enables privileged EXEC mode. Enter your password if prompted.                                                                                                                                                                                                                                                                                                                                                                                                                                                                                                                                                                                                                             |
| <b>Step 2</b> | <b>configure terminal</b><br><b>Example:</b><br><pre>Router# configure terminal Router(config)#</pre>                                                                          | Enters global configuration mode.                                                                                                                                                                                                                                                                                                                                                                                                                                                                                                                                                                                                                                                          |
| <b>Step 3</b> | <b>cable source-verify enable-sav-static</b><br><b>Example:</b><br><pre>Router# cable source-verify enable-sav-static Router(config)#</pre>                                    | Enables SAV prefix processing on the Cisco CMTS.                                                                                                                                                                                                                                                                                                                                                                                                                                                                                                                                                                                                                                           |
| <b>Step 4</b> | <b>cable source-verify group <i>groupname</i></b><br><b>Example:</b><br><pre>Router(config)# cable source-verify group sav-1</pre>                                             | Configures the SAV group name.<br><br><i>groupname</i> — Name of the SAV group with a maximum length of 16 characters.                                                                                                                                                                                                                                                                                                                                                                                                                                                                                                                                                                     |
| <b>Step 5</b> | <b>prefix [ipv4_prefix/ipv4_prefix_length   ipv6_prefix/ipv6_prefix_length ]</b><br><b>Example:</b><br><pre>Router(config-sav)# prefix 10.10.10.0/24 Router(config-sav)#</pre> | Configures the IPv4 or IPv6 prefix associated with the SAV group. <ul style="list-style-type: none"> <li>• <i>ipv4_prefix</i>— IPv4 prefix associated with the SAV group, specified in the X.X.X.X/X format.</li> <li>• <i>ipv4_prefix_length</i>—Length of the IPv4 prefix. The valid range is from 0 to 32.</li> <li>• <i>ipv6_prefix</i>—IPv6 prefix associated with a particular SAV group, specified in the X:X:X:X::/X format.</li> <li>• <i>ipv6_prefix_length</i>—Length of the IPv6 prefix. The valid range is from 0 to 128.</li> </ul> A maximum of four prefixes can be configured in a single SAV group. These prefixes can be either IPv4s, IPv6s, or a combination of both. |
| <b>Step 6</b> | <b>exit</b><br><b>Example:</b><br><pre>Router(config-sav)# exit</pre>                                                                                                          | Exits SAV configuration mode.                                                                                                                                                                                                                                                                                                                                                                                                                                                                                                                                                                                                                                                              |

|        | Command or Action                                             | Purpose                          |
|--------|---------------------------------------------------------------|----------------------------------|
| Step 7 | <b>exit</b><br><b>Example:</b><br>Router(config)# <b>exit</b> | Exits global configuration mode. |

## Configuring Optional DHCP Parameters

When using an external DHCP server, the Cisco CMTS supports a number of options that can enhance operation of the cable network in certain applications. To configure these options, use the following procedure, beginning in EXEC mode.

### Procedure

|        | Command or Action                                                                                                  | Purpose                                                                                                                                                                                                                                                                                                                                                                                                                                                                                                                                                                                                                                                                                                                                                           |
|--------|--------------------------------------------------------------------------------------------------------------------|-------------------------------------------------------------------------------------------------------------------------------------------------------------------------------------------------------------------------------------------------------------------------------------------------------------------------------------------------------------------------------------------------------------------------------------------------------------------------------------------------------------------------------------------------------------------------------------------------------------------------------------------------------------------------------------------------------------------------------------------------------------------|
| Step 1 | <b>enable</b><br><b>Example:</b><br>Router> <b>enable</b><br>Router#                                               | Enables privileged EXEC mode. Enter your password if prompted.                                                                                                                                                                                                                                                                                                                                                                                                                                                                                                                                                                                                                                                                                                    |
| Step 2 | <b>configure terminal</b><br><b>Example:</b><br>Router# <b>configure terminal</b><br>Router(config)#               | Enters global configuration mode.                                                                                                                                                                                                                                                                                                                                                                                                                                                                                                                                                                                                                                                                                                                                 |
| Step 3 | <b>ip dhcp smart-relay</b><br><b>Example:</b><br>Router(config)# <b>ip dhcp smart-relay</b><br>Router(config)#     | (Optional) Enables the DHCP relay agent on the CMTS to automatically switch a cable modem or CPE device to a secondary DHCP server or address pool if the primary DHCP server does not respond to three successive requests. If multiple secondary servers have been defined, the relay agent forwards DHCP requests to the secondary servers in a round robin fashion.                                                                                                                                                                                                                                                                                                                                                                                           |
| Step 4 | <b>ip dhcp ping packet 0</b><br><b>Example:</b><br>Router(config)# <b>ip dhcp ping packet 0</b><br>Router(config)# | (Optional) Instructs the DHCP server to assign an IP address from its pool without first sending an ICMP ping to test whether a client is already currently using that IP address. Disabling the ping option can speed up address assignment when a large number of modems are trying to connect at the same time. However, disabling the ping option can also result in duplicate IP addresses being assigned if users assign unauthorized static IP addresses to their CPE devices.<br><br><b>Note</b> By default, the DHCP server pings a pool address twice before assigning a particular address to a requesting client. If the ping is unanswered, the DHCP server assumes that the address is not in use and assigns the address to the requesting client. |

|               | Command or Action                                                                                                                                                                                   | Purpose                                                                                                                                                                                                                                                                                                                                                                                                                                                                                                                                                                                                                                                                                                                                                                                                                                                                                                                                   |
|---------------|-----------------------------------------------------------------------------------------------------------------------------------------------------------------------------------------------------|-------------------------------------------------------------------------------------------------------------------------------------------------------------------------------------------------------------------------------------------------------------------------------------------------------------------------------------------------------------------------------------------------------------------------------------------------------------------------------------------------------------------------------------------------------------------------------------------------------------------------------------------------------------------------------------------------------------------------------------------------------------------------------------------------------------------------------------------------------------------------------------------------------------------------------------------|
| <b>Step 5</b> | <p><b>ip dhcp relay information check</b></p> <p><b>Example:</b></p> <pre>Router(config)# ip dhcp relay information check Router(config)#</pre>                                                     | <p>(Optional) Configures the DHCP server to validate the relay agent information option in forwarded BOOTREPLY messages. Invalid messages are dropped.</p> <p><b>Note</b> The <b>ip dhcp relay information</b> command contains several other options that might be useful for special handling of DHCP packets. See its command reference page in the Cisco IOS-XE documentation for details.</p>                                                                                                                                                                                                                                                                                                                                                                                                                                                                                                                                        |
| <b>Step 6</b> | <p><b>interface cable x/y</b></p> <p><b>Example:</b></p> <pre>Router(config)# interface cable 4/0 Router(config-if)#</pre>                                                                          | <p>Enters cable interface configuration mode for the specified cable interface.</p>                                                                                                                                                                                                                                                                                                                                                                                                                                                                                                                                                                                                                                                                                                                                                                                                                                                       |
| <b>Step 7</b> | <p><b>cable dhcp-giaddr policy [host   stb   mta   ps  profile name] giaddr</b></p> <p><b>Example:</b></p> <pre>Router(config-if)# cable dhcp-giaddr policy mta 172.1.1.10 Router(config-if)#</pre> | <p>Sets the DHCP GIADDR field for DHCP request packets to the primary address for cable modems, and the secondary address for CPE devices. This enables the use of separate address pools for different clients.</p> <ul style="list-style-type: none"> <li>• <b>host</b>—Specifies the GIADDR for hosts.</li> <li>• <b>mta</b>—Specifies the GIADDR for MTAs.</li> <li>• <b>ps</b>—Specifies the GIADDR for PSs.</li> <li>• <b>stb</b>—Specifies the GIADDR for STBs.</li> <li>• <b>profile name</b> Specifies DHCP profile as control policy.</li> <li>• <b>giaddr</b>—IP addresses of the secondary interface of the bundle interface.</li> </ul> <p><b>Note</b> The <b>cable dhcp-giaddr</b> command also supports the <b>primary</b> option. The <b>primary</b> option forces all device types to use only the primary interface IP address as GIADDR and not rotate through the secondary address if the primary address fails.</p> |
| <b>Step 8</b> | <p><b>cable helper-address address [cable-modem   host   mta   stb  profile name]</b></p> <p><b>Example:</b></p> <pre>Router(config-if)# cable helper-address 10.10.10.13 Router(config-if)#</pre>  | <p>(Optional) Enables load-balancing of DHCP requests from cable modems and CPE devices by specifying different DHCP servers according to the cable interface or subinterface. You can also specify separate servers for cable modems and CPE devices.</p> <ul style="list-style-type: none"> <li>• <b>address</b> = IP address of a DHCP server to which UDP broadcast packets will be sent via unicast packets.</li> <li>• <b>cable-modem</b> = Specifies this server should only accept cable modem packets (optional).</li> <li>• <b>host</b> = Specifies this server should only accept CPE device packets (optional).</li> </ul>                                                                                                                                                                                                                                                                                                    |



|         | Command or Action                                                                                                    | Purpose                                                                                                                                                                                                                                                                                                                                                                                                                                                                                                                                                                                                                                                                                                                                                                                                                                                                                                                                                                                                                                                                                                                                                                                                                                                                                                                                                                                                                                                                                                                                                             |
|---------|----------------------------------------------------------------------------------------------------------------------|---------------------------------------------------------------------------------------------------------------------------------------------------------------------------------------------------------------------------------------------------------------------------------------------------------------------------------------------------------------------------------------------------------------------------------------------------------------------------------------------------------------------------------------------------------------------------------------------------------------------------------------------------------------------------------------------------------------------------------------------------------------------------------------------------------------------------------------------------------------------------------------------------------------------------------------------------------------------------------------------------------------------------------------------------------------------------------------------------------------------------------------------------------------------------------------------------------------------------------------------------------------------------------------------------------------------------------------------------------------------------------------------------------------------------------------------------------------------------------------------------------------------------------------------------------------------|
|         |                                                                                                                      | <ul style="list-style-type: none"> <li>• <b>mta</b>—(Optional) Specifies this server should only accept MTA packets .</li> <li>• <b>stb</b> —(Optional) Specifies this server should only accept STB packets .</li> <li>• <b>profile name</b>—(Optional) Specifies that only UDP broadcasts with specific DHCP profile are forwarded.</li> </ul> <p><b>Note</b> If you do not specify an option, the helper-address will support all cable devices, and the associated DHCP server will accept DHCP packets from all cable device classes.</p> <p><b>Note</b> If you specify only one option, the other types of devices (cable modem, host, mta, or stb) will not be able to connect with a DHCP server. You must specify each desired option in a separate command .</p> <p><b>Tip</b> Repeat this command to specify more than one helper address on each cable interface. You can specify more than 16 helper addresses, but the Cisco IOS software uses only the first 16 valid addresses.</p> <p><b>Tip</b> If you configure different helper addresses on different sub-bundles within a bundle, the cable modem may not come online. We recommend that you use the same helper address on all sub-bundles within a bundle.</p> <p><b>Note</b> The <b>ip helper-address</b> command performs a similar function to <b>cable helper-address</b>, but it should be used on non-cable interfaces. The <b>cable helper-address</b> command should be used on cable interfaces because it is optimized for the operation of DHCP requests on DOCSIS networks.</p> |
| Step 9  | <p><b>cable dhcp-giaddr policy</b></p> <p><b>Example:</b></p> <pre>Router(config-if)# cable dhcp-giaddr policy</pre> | Selects the control policy, so the primary address is used for cable modems and the secondary addresses are used for hosts and other customer premises equipment (CPE) devices. This setting is typically used when the CMs on the interface are configured for routing mode, so that the cabel modems and hosts can use IP addresses on different subnets.                                                                                                                                                                                                                                                                                                                                                                                                                                                                                                                                                                                                                                                                                                                                                                                                                                                                                                                                                                                                                                                                                                                                                                                                         |
| Step 10 | <p><b>exit</b></p> <p><b>Example:</b></p>                                                                            | Exits interface configuration mode.                                                                                                                                                                                                                                                                                                                                                                                                                                                                                                                                                                                                                                                                                                                                                                                                                                                                                                                                                                                                                                                                                                                                                                                                                                                                                                                                                                                                                                                                                                                                 |

|                | Command or Action                                                               | Purpose                          |
|----------------|---------------------------------------------------------------------------------|----------------------------------|
|                | Router (config-if) # <b>exit</b><br>Router (config) #                           |                                  |
| <b>Step 11</b> | <b>exit</b><br><b>Example:</b><br><br>Router (config) # <b>exit</b><br>Router # | Exits global configuration mode. |

## How to Configure ToD, and TFTP Services

See the following configuration tasks required to configure time-of-day service, and TFTP service on a Cisco CMTS:

## Configuration Examples

This section provides examples for the following configurations:

### ToD Server Example

The following example shows a typical ToD server configuration:

```
service udp-small-servers max-servers no-limit
cable time-server
```

These are the only commands required to enable the ToD server.

### TFTP Server Example

The following lines are an excerpt from a configuration that includes a TFTP server. Change the files listed with the **tftp-server** command to match the specific files that are on your system.

```
! Enable the user of unlimited small servers
service udp-small-servers max-servers no-limit
!
...
! Enable the TFTP server and specify the files that can be
! downloaded along with their aliases
tftp-server disk0:gold.cm alias gold.cm
tftp-server disk0:silver.cm alias silver.cm
tftp-server disk0:bronze.cm alias bronze.cm
tftp-server disk0:ubr924-k8y5-mz.bin alias ubr924-codefile
tftp-server disk0:ubr925-k9v9y5-mz.bin alias ubr925-codefile
```

## Additional References

### Technical Assistance

| Description                                                                                                                                                                                                                                                                                                                                                                                                                                                                                                                                                             | Link                                                                    |
|-------------------------------------------------------------------------------------------------------------------------------------------------------------------------------------------------------------------------------------------------------------------------------------------------------------------------------------------------------------------------------------------------------------------------------------------------------------------------------------------------------------------------------------------------------------------------|-------------------------------------------------------------------------|
| <p>The Cisco Support website provides extensive online resources, including documentation and tools for troubleshooting and resolving technical issues with Cisco products and technologies.</p> <p>To receive security and technical information about your products, you can subscribe to various services, such as the Product Alert Tool (accessed from Field Notices), the Cisco Technical Services Newsletter, and Really Simple Syndication (RSS) Feeds.</p> <p>Access to most tools on the Cisco Support website requires a Cisco.com user ID and password.</p> | <a href="http://www.cisco.com/support">http://www.cisco.com/support</a> |

## Feature Information for the DHCP, ToD, and TFTP Services for the CMTS Routers

Use Cisco Feature Navigator to find information about the platform support and software image support. Cisco Feature Navigator enables you to determine which software images support a specific software release, feature set, or platform. To access Cisco Feature Navigator, go to the <https://cfmg.cisco.com/> link. An account on the Cisco.com page is not required.



**Note** The following table lists the software release in which a given feature is introduced. Unless noted otherwise, subsequent releases of that software release train also support that feature.

*Table 219: Feature Information for Downstream Interface Configuration*

| Feature Name                                      | Releases                       | Feature Information                                                                                            |
|---------------------------------------------------|--------------------------------|----------------------------------------------------------------------------------------------------------------|
| DHCP, ToD, and TFTP services                      | Cisco IOS XE Fuji 16.7.1       | This feature was integrated into Cisco IOS XE Fuji 16.7.1 on the Cisco cBR Series Converged Broadband Routers. |
| Sniff out boot file name from DHCP process per CM | Cisco IOS XE Gibraltar 16.12.1 | This feature was supported on the Cisco cBR Series Converged Broadband Routers.                                |





## CHAPTER 61

# Virtual Interface Bundling

---

Virtual Interface Bundling allows supports combining multiple cable interfaces in a Cisco cBR series router into a single logical bundle, so as to conserve IP address space and simplify network management.

Your software release may not support all the features that are documented in this module. For the latest feature information and caveats, see the release notes for your platform and software release. The Feature Information Table at the end of this document provides information about the documented features and lists the releases in which each feature is supported.

Use Cisco Feature Navigator to find information about platform support and Cisco software image support. To access Cisco Feature Navigator, go to <http://tools.cisco.com/ITDIT/CFN/>. An account on <http://www.cisco.com/> is not required.

### Contents

- [Hardware Compatibility Matrix for the Cisco cBR Series Routers, on page 1017](#)
- [Information About Virtual Interface Bundling, on page 1018](#)
- [Configuring Virtual Interface Bundling, on page 1021](#)
- [Verfiying the Virtual Interface Bundling Configuration, on page 1023](#)
- [Additional References, on page 1025](#)
- [Feature Information for Virtual Interface Bundling, on page 1026](#)

## Hardware Compatibility Matrix for the Cisco cBR Series Routers



---

**Note** The hardware components that are introduced in a given Cisco IOS-XE Release are supported in all subsequent releases unless otherwise specified.

---

Table 220: Hardware Compatibility Matrix for the Cisco cBR Series Routers

| Cisco CMTS Platform                    | Processor Engine                                                                                                                                                                                  | Interface Cards                                                                                                                                                                                                                                                                                                                                                                                                                                                                                                                                                                                                                                                                                                                                                                                 |
|----------------------------------------|---------------------------------------------------------------------------------------------------------------------------------------------------------------------------------------------------|-------------------------------------------------------------------------------------------------------------------------------------------------------------------------------------------------------------------------------------------------------------------------------------------------------------------------------------------------------------------------------------------------------------------------------------------------------------------------------------------------------------------------------------------------------------------------------------------------------------------------------------------------------------------------------------------------------------------------------------------------------------------------------------------------|
| Cisco cBR-8 Converged Broadband Router | <p><b>Cisco IOS-XE Release 16.5.1 and Later Releases</b></p> <p>Cisco cBR-8 Supervisor:</p> <ul style="list-style-type: none"> <li>• PID—CBR-SUP-250G</li> <li>• PID—CBR-CCAP-SUP-160G</li> </ul> | <p><b>Cisco IOS-XE Release 16.5.1 and Later Releases</b></p> <p>Cisco cBR-8 CCAP Line Cards:</p> <ul style="list-style-type: none"> <li>• PID—CBR-LC-8D30-16U30</li> <li>• PID—CBR-LC-8D31-16U30</li> <li>• PID—CBR-RF-PIC</li> <li>• PID—CBR-RF-PROT-PIC</li> <li>• PID—CBR-CCAP-LC-40G</li> <li>• PID—CBR-CCAP-LC-40G-R</li> <li>• PID—CBR-CCAP-LC-G2-R</li> <li>• PID—CBR-SUP-8X10G-PIC</li> <li>• PID—CBR-2X100G-PIC</li> </ul> <p>Digital PICs:</p> <ul style="list-style-type: none"> <li>• PID—CBR-DPIC-8X10G</li> <li>• PID—CBR-DPIC-2X100G</li> </ul> <p>Cisco cBR-8 Downstream PHY Module:</p> <ul style="list-style-type: none"> <li>• PID—CBR-D31-DS-MOD</li> </ul> <p>Cisco cBR-8 Upstream PHY Modules:</p> <ul style="list-style-type: none"> <li>• PID—CBR-D31-US-MOD</li> </ul> |



**Note** Do not use DPICs (8X10G and 2x100G) to forward IP traffic, as it may cause buffer exhaustion, leading to line card reload.

The only allowed traffic on a DPIC interface is DEPI, UEPI, and GCP traffic from the Cisco cBR-8 router to Remote PHY devices. Other traffic such as DHCP, SSH, and UTSC should flow via another router, since DPICs cannot be used for normal routing.

## Information About Virtual Interface Bundling

This section contains the following:

## Overview of Virtual Interface Bundling



---

**Note** All cable bundles are automatically converted and configured to virtual interface bundles. Any standalone cable interfaces must be manually configured to be in a virtual bundle to operate properly.

---

Virtual interface bundling supports the following:

- Virtual interface bundling uses *bundle interface* and *bundle members* instead of primary or secondary interfaces.
- A virtual bundle interface is virtually defined, as with IP loopback addresses.
- Virtual interface bundling supports bundle information in multiple **show** commands.
- The CISCO-DOCS-EXT-MIB is updated for cable helper-address and IPv6 DHCP relay configurations.

Virtual interface bundling prevents loss of connectivity on physical interfaces should there be a failure, problematic online insertion and removal (OIR) of one line card in the bundle, or erroneous removal of configuration on the primary interface.

Virtual interface bundling supports and governs the following Layer 3 settings for the bundle member interfaces:

- IP address
- IP helper-address
- source-verify and lease-timer functions
- cable dhcp-giaddr (The giaddr field is set to the IP address of the DHCP client.)
- Protocol Independent Multicast (PIM)
- Access control lists (ACLs)
- Sub-interfaces
- IPv6
- 1982 bytes layer 3 MTU.



---

**Note** In case customer wants to test 1982 bytes MTU by issuing a ping from CMTS to DOCSIS 3.1 modem, **cable mtu-override** command needs to be configured. After the test, please remove this configuration using **no cable mtu-override** command. By default, there is no cable mtu-override configured in bundle interface.

---



---

**Note** This virtual interface for the bundle should always remain on (enabled with **no shutdown**).

---

## Guidelines for Virtual Interface Bundling

The following guidelines describe virtual interface bundling:

- Initial configuration of the first virtual bundle *member* automatically creates a virtual bundle interface.
- All cable bundles are automatically converted and configured to be in a virtual bundle after loading the software image.
- Standalone cable interfaces must be manually configured to be in a virtual bundle to operate properly.
- The virtual bundle interface accumulates the counters from members; counters on member links are not cleared when they are added to the bundle. If a bundle-only counter is desired, clear the bundle counter on the members before adding them to the bundle, or before loading the image.
- This feature supports a maximum of 40 virtual interface bundles, with the numeric range from 1 to 255.
- The virtual bundle interface remains configured unless specifically deleted, even if all members in the bundle are deleted.
- This feature supports subinterfaces on the virtual bundle interface.
- *Bundle-aware* configurations are supported on the virtual bundle interface.
- *Bundle-unaware* configurations are supported on each bundle member.
- While creating the virtual bundle interface, if the bundle interface existed in earlier Cisco IOS releases, then the earlier cable configurations re-appear after upgrade.
- When using sub-bundle, all layer 3 configurations must be configured on sub-bundle, instead of main bundle.

## Virtual Interface Bundle-aware and Bundle-unaware Support

Virtual interface bundling uses two configurations: the virtual *bundle* itself, and the interfaces in that virtual bundle, known as *bundle members*. The virtual interface bundle and bundle members are either aware of the bundle, or unaware of the bundle, as follows.

- Bundle-aware features are maintained on the virtual *bundle*. These include:
  - IP Address
  - IP helper, cable helper
  - Dhcp-giaddr
  - Sub-interface
  - Source verify
  - Lease-query
  - Address Resolution Protocol (Cable ARP filtering, which also bundles cable interfaces, and Proxy ARP)
  - Cable match
  - Access Control Lists (ACLs)
  - Protocol Independent Multicast (PIM)
  - Cable Intercept
- Bundle-unaware features are maintained on the *bundle members*. These include:



- DS/US configurations
- HCCP redundancy
- Load balancing
- DMIC, tftp-enforce, shared-secret
- Spectrum management
- Admission control
- Intercept

## Configuring Virtual Interface Bundling

To enable virtual interface bundling, and to reconfigure interface information on the Cisco CMTS as required, you first configure the virtual interface bundle, then add additional bundle members for the specified virtual bundle. Perform these steps on each interface, as needed for all virtual interface bundles.

### Procedure

|               | Command or Action                                                                                                                                             | Purpose                                                                                                                                                                                                                                                                                                                   |
|---------------|---------------------------------------------------------------------------------------------------------------------------------------------------------------|---------------------------------------------------------------------------------------------------------------------------------------------------------------------------------------------------------------------------------------------------------------------------------------------------------------------------|
| <b>Step 1</b> | <b>enable</b><br><b>Example:</b><br>Router> enable                                                                                                            | Enables privileged EXEC mode. <ul style="list-style-type: none"> <li>• Enter your password if prompted.</li> </ul>                                                                                                                                                                                                        |
| <b>Step 2</b> | <b>configure terminal</b><br><b>Example:</b><br>Router# configure terminal                                                                                    | Enters global configuration mode.                                                                                                                                                                                                                                                                                         |
| <b>Step 3</b> | <b>interface bundle <i>n</i></b><br><b>Example:</b><br>Router(config-if)# interface bundle 1                                                                  | Adds the selected interface to the virtual bundle. If this is the first interface on which the virtual bundle is configured, this command enables the bundle on the specified interface.<br><br>As many as 40 virtual interface bundles can be configured on the Cisco CMTS. Numeric identifiers may range from 1 to 255. |
| <b>Step 4</b> | <b>ip address <i>address mask</i></b><br><b>Example:</b><br>Router(config-if)# ip address 7.7.7.7<br>255.255.255.0                                            | Use as needed after Cisco IOS upgrade.<br><br>Configures the IP address for the specified interface and virtual bundle.                                                                                                                                                                                                   |
| <b>Step 5</b> | <b>cable helper-address <i>address</i> [cable-modem   host   mta   ps   stb]</b><br><b>Example:</b><br>Router(config-if)# cable helper-address<br>10.10.10.13 | (Optional) Specifies the IPv4 DHCP server address.                                                                                                                                                                                                                                                                        |

|                | Command or Action                                                                                                                                          | Purpose                                                                                                                                                                                                                                                                                                                                                                                                                                                                                                                                                                                                |
|----------------|------------------------------------------------------------------------------------------------------------------------------------------------------------|--------------------------------------------------------------------------------------------------------------------------------------------------------------------------------------------------------------------------------------------------------------------------------------------------------------------------------------------------------------------------------------------------------------------------------------------------------------------------------------------------------------------------------------------------------------------------------------------------------|
| <b>Step 6</b>  | <b>cable dhcp-giaddr</b> {primary   policy [host   stb   mta   ps   strict]}<br><b>Example:</b><br>Router(config-if)# <b>cable dhcp-giaddr policy host</b> | Sets the DHCP GIADDR field for DHCP request packets.                                                                                                                                                                                                                                                                                                                                                                                                                                                                                                                                                   |
| <b>Step 7</b>  | <b>cable source-verify dhcp</b><br><b>Example:</b><br>Router(config-if)# <b>cable source-verify dhcp</b>                                                   | (Optional) Ensures that the Cisco CMTS allows network access only to those IP addresses that DHCP servers issued to devices on this cable interface. The Cisco CMTS examines the DHCP packets that pass through the cable interfaces to build a database of which IP addresses are valid on which interface. Drops traffic from all devices with unknown IP addresses, but the Cisco CMTS also sends a query to the DHCP servers for any information about the device. If a DHCP server informs the Cisco CMTS that the device has a valid IP address, the CMTS then allows the device on the network. |
| <b>Step 8</b>  | <b>no cable arp</b><br><b>Example:</b><br>Router(config-if)# <b>no cable arp</b>                                                                           | (Optional) Blocks the static IPv4 CPE from coming online. Also blocks Address Resolution Protocol (ARP) process destined to devices on the cable network.<br><br><b>Note</b> Use this command, together with the <b>cable source-verify dhcp</b> command, to block certain types of scanning attacks that attempt to cause denial of service (DoS) on the Cisco CMTS.                                                                                                                                                                                                                                  |
| <b>Step 9</b>  | <b>exit</b><br><b>Example:</b><br>Router(config-if)# <b>exit</b>                                                                                           | Exits the interface configuration mode and enters global configuration mode.                                                                                                                                                                                                                                                                                                                                                                                                                                                                                                                           |
| <b>Step 10</b> | <b>interface cable</b> slot/subslot/port<br><b>Example:</b><br>Router(config)# <b>interface cable 3/0/0</b>                                                | Enters interface configuration mode for the selected interface, on which virtual interface bundling is to be enabled.                                                                                                                                                                                                                                                                                                                                                                                                                                                                                  |
| <b>Step 11</b> | <b>cable bundle</b> n<br><b>Example:</b><br>Router(config-if)# <b>cable bundle 1</b>                                                                       | Configures a cable interface to belong to an interface bundle, where n is the bundle number.                                                                                                                                                                                                                                                                                                                                                                                                                                                                                                           |
| <b>Step 12</b> | <b>no cable upstream</b> n shut<br><b>Example:</b><br>Router(config-if)# <b>no cable upstream 4 shut</b>                                                   | Use as needed after Cisco IOS upgrade.<br><br>The cable interface must be enabled using the no shutdown command for the specified cable interface.<br><br>n —Specifies the cable interface to enable for the virtual bundle.                                                                                                                                                                                                                                                                                                                                                                           |

|         | Command or Action                                                       | Purpose                          |
|---------|-------------------------------------------------------------------------|----------------------------------|
| Step 13 | <b>end</b><br><br><b>Example:</b><br><br>Router(config-if) # <b>end</b> | Returns to privileged EXEC mode. |

### What to do next

To remove a virtual bundle from the interface, use the **no interface bundle** command in interface configuration mode, where *n* specifies the bundle identifier:

#### no interface bundle *n*

If you remove a member from a bundle, the bundle remains on the interface (even if empty) until the bundle itself is specifically removed.

For more information on configuring IPv6 parameters for bundle interface, see *IPv6 on Cable* feature guide.

## Verifying the Virtual Interface Bundling Configuration

- **show ip interface brief**—Displays the summary of interfaces.

Following is a sample output of this command:

```
Router# show ip interface brief
```

```

Interface          IP-Address      OK? Method Status          Protocol
Cable3/0/0         Bundle1         YES unset    up              up
GigabitEthernet0  10.86.3.175    YES NVRAM   administratively down down
Bundle1           100.1.2.1     YES manual up              up
Bundle2           100.1.3.1     YES NVRAM up              up
Dt14/1/0           unassigned     YES unset    administratively down down
Dt15/1/0           unassigned     YES unset    administratively down down
Dt14/1/1           unassigned     YES unset    administratively down down
Dt15/1/1           unassigned     YES unset    administratively down down
Loopback1         1.2.3.4        YES NVRAM   up              up
Tunnel0           unassigned     YES unset    up              up

```

- **show running-config interface bundle *n***—Displays the information about the specified bundle.

Following is a sample output of this command:

```
Router# show running-config interface Bundle 1
```

```

Current configuration : 696 bytes
!
interface Bundle2
 ip address 100.1.3.1 255.255.255.0
 no cable nd
 cable arp filter request-send 3 2
 cable arp filter reply-accept 3 2
 no cable arp
 cable ipv6 source-verify dhcp
 cable source-verify dhcp
 cable dhcp-giaddr primary
 cable helper-address 10.10.0.53
 ipv6 address 2001:420:3800:910::1/64

```

```

ipv6 enable
ipv6 nd reachable-time 3600000
ipv6 nd cache expire 65536
ipv6 nd managed-config-flag
ipv6 nd other-config-flag
ipv6 nd ra interval msec 2000
no ipv6 redirects
ipv6 dhcp relay destination 2001:420:3800:800:250:56FF:FEB2:F11D
ipv6 dhcp relay destination vrf vrfa 2001:420:3800:800:250:56FF:FEB2:F11D
ipv6 dhcp relay source-interface Bundle2
arp timeout 2147483

```

- **show ip interface brief | include bundle**—Displays the bundle interface information.

Following is a sample output of this command:

```

Router# show ip interface brief | include Bundle

Bundle1 unassigned YES unset up up
Bundle1.1 100.1.2.1 YES NVRAM up up
Bundle2 100.1.3.1 YES NVRAM up up

```

- **show running-config interface bundle *n.n***—Displays the subinterface information for the specified bundle.

Following is a sample output of this command:

```

Router# show running-config interface bundle 1.1

Current configuration : 1415 bytes
!
interface Bundle1.1
ip address 100.1.2.1 255.255.255.0
ip pim sparse-mode
ip rip send version 2
ip rip receive version 2
ip rip authentication mode md5
ip rip authentication key-chain ubr-rip
ip igmp static-group 239.1.4.1 source 115.255.0.100
ip igmp static-group 239.1.3.1 source 115.255.0.100
ip igmp static-group 239.1.2.1 source 115.255.0.100
ip igmp static-group 232.1.4.1 source 115.255.0.100
ip igmp static-group 232.1.3.1 source 115.255.0.100
ip igmp static-group 232.1.2.1 source 115.255.0.100
ip igmp static-group 232.1.1.1 source 115.255.0.100
ip igmp static-group 230.1.4.1
ip igmp static-group 230.1.3.1
ip igmp static-group 230.1.2.1
ip igmp static-group 224.1.4.1
ip igmp static-group 224.1.3.1
ip igmp static-group 224.1.2.1
ip igmp static-group 224.1.1.1
ip igmp version 3
ip igmp query-interval 20
no cable arp
cable ipv6 source-verify dhcp
cable source-verify dhcp
cable dhcp-giaddr primary
cable helper-address 10.10.0.53
ipv6 address 2001:420:3800:909::1/64
ipv6 enable
ipv6 nd reachable-time 3600000
ipv6 nd cache expire 65536

```

```

ipv6 nd prefix default no-advertise
ipv6 nd managed-config-flag
ipv6 nd other-config-flag
ipv6 nd ra interval msec 2000
no ipv6 redirects
ipv6 dhcp relay destination 2001:420:3800:800:250:56FF:FEB2:F11D link-address
2001:420:3800:909::1
ipv6 dhcp relay source-interface Bundle1
ipv6 rip CST enable
arp timeout 2147483

```

## Additional References

### Related Documents

| Related Topic          | Document Title                                               |
|------------------------|--------------------------------------------------------------|
| CMTS Command Reference | <a href="#">Cisco IOS CMTS Cable Command Reference Guide</a> |

### Standards and RFCs

| Standards              | Title                                                                                                           |
|------------------------|-----------------------------------------------------------------------------------------------------------------|
| SP-RFIV1.1-I09-020830  | Data-over-Cable Service Interface Specifications Radio Frequency Interface Specification, version 1.1           |
| SP-RFIV2.0-I03-021218  | Data-over-Cable Service Interface Specifications Radio Frequency Interface Specification, version 2.0           |
| SP-OSSIV2.0-I03-021218 | Data-over-Cable Service Interface Specifications Operations Support System Interface Specification, version 2.0 |
| SP-BPI+-I09-020830     | Data-over-Cable Service Interface Specifications Baseline Privacy Plus Interface Specification, version 2.0     |

### Technical Assistance

| Description                                                                                                                                                                                                                                                                                                                                                                                                                                                                                                                                                             | Link                                                                    |
|-------------------------------------------------------------------------------------------------------------------------------------------------------------------------------------------------------------------------------------------------------------------------------------------------------------------------------------------------------------------------------------------------------------------------------------------------------------------------------------------------------------------------------------------------------------------------|-------------------------------------------------------------------------|
| <p>The Cisco Support website provides extensive online resources, including documentation and tools for troubleshooting and resolving technical issues with Cisco products and technologies.</p> <p>To receive security and technical information about your products, you can subscribe to various services, such as the Product Alert Tool (accessed from Field Notices), the Cisco Technical Services Newsletter, and Really Simple Syndication (RSS) Feeds.</p> <p>Access to most tools on the Cisco Support website requires a Cisco.com user ID and password.</p> | <a href="http://www.cisco.com/support">http://www.cisco.com/support</a> |

# Feature Information for Virtual Interface Bundling

Use Cisco Feature Navigator to find information about the platform support and software image support. Cisco Feature Navigator enables you to determine which software images support a specific software release, feature set, or platform. To access Cisco Feature Navigator, go to the <https://cfng.cisco.com/> link. An account on the Cisco.com page is not required.



**Note** The following table lists the software release in which a given feature is introduced. Unless noted otherwise, subsequent releases of that software release train also support that feature.

*Table 221: Feature Information for Virtual Interface Bundling*

| Feature Name               | Releases                 | Feature Information                                                                                            |
|----------------------------|--------------------------|----------------------------------------------------------------------------------------------------------------|
| Virtual interface bundling | Cisco IOS XE Fuji 16.7.1 | This feature was integrated into Cisco IOS XE Fuji 16.7.1 on the Cisco cBR Series Converged Broadband Routers. |



## CHAPTER 62

# IPv6 on Cable

Cisco cBR series Converged Broadband Router supports full IPv6 functionality.

The IPv6 feature support available in the Cisco IOS software and for Cisco CMTS routers is extensive. This document provides a comprehensive overview of all of the IPv6 features supported on the Cisco CMTS routers, and their restrictions.

However, the details of every feature are not covered in this document. The areas of IPv6 protocol support for the Cisco CMTS routers discussed in this document are classified by platform-independence or by platform-specific feature support.

- Platform-independent IPv6 features—Describes IPv6 features that are supported in the Cisco IOS software for several other Cisco platforms, and which generally do not have any platform-specific behavior or configuration differences on the Cisco CMTS routers.
- Documentation about the restrictions for these platform-independent features can be found in the Restrictions for IPv6 on Cable.
- Detailed information about these features, including conceptual and task-based configuration information, is documented outside of this feature and in the Cisco IOS software documentation. Detailed information about the location of this related documentation in the Cisco IOS software documentation is described in the Feature Information for IPv6 on Cable.

Platform-specific IPv6 features—Describes IPv6 features that are specific to the cable technology area and that only apply to the supported Cisco CMTS routers. The cable-specific IPv6 feature support includes new or modified cable features supporting IPv6, and any transparent support of the IPv6 protocol in existing (legacy) cable features on the CMTS router platforms.

Your software release may not support all the features that are documented in this module. For the latest feature information and caveats, see the release notes for your platform and software release. The Feature Information Table at the end of this document provides information about the documented features and lists the releases in which each feature is supported.

Use Cisco Feature Navigator to find information about platform support and Cisco software image support. To access Cisco Feature Navigator, go to <http://tools.cisco.com/ITDIT/CFN/>. An account on <http://www.cisco.com/> is not required.

- [Hardware Compatibility Matrix for the Cisco cBR Series Routers](#), on page 1028
- [Restrictions for IPv6 on Cable](#), on page 1029
- [Information About IPv6 on Cable](#), on page 1030
- [How to Configure IPv6 on Cable](#), on page 1039
- [How to Verify IPv6 Dual Stack CPE Support](#), on page 1054

- [Configuration Examples for IPv6 on Cable](#), on page 1056
- [Verifying IPv6 on Cable](#), on page 1066
- [Supported MIBs](#), on page 1068
- [Additional References](#), on page 1069
- [Feature Information for IPv6 on Cable](#), on page 1069

## Hardware Compatibility Matrix for the Cisco cBR Series Routers



**Note** The hardware components that are introduced in a given Cisco IOS-XE Release are supported in all subsequent releases unless otherwise specified.

**Table 222: Hardware Compatibility Matrix for the Cisco cBR Series Routers**

| Cisco CMTS Platform                    | Processor Engine                                                                                                                                                                                  | Interface Cards                                                                                                                                                                                                                                                                                                                                                                                                                                                                                                                                                                                                                                                                                                                                                                                 |
|----------------------------------------|---------------------------------------------------------------------------------------------------------------------------------------------------------------------------------------------------|-------------------------------------------------------------------------------------------------------------------------------------------------------------------------------------------------------------------------------------------------------------------------------------------------------------------------------------------------------------------------------------------------------------------------------------------------------------------------------------------------------------------------------------------------------------------------------------------------------------------------------------------------------------------------------------------------------------------------------------------------------------------------------------------------|
| Cisco cBR-8 Converged Broadband Router | <p><b>Cisco IOS-XE Release 16.5.1 and Later Releases</b></p> <p>Cisco cBR-8 Supervisor:</p> <ul style="list-style-type: none"> <li>• PID—CBR-SUP-250G</li> <li>• PID—CBR-CCAP-SUP-160G</li> </ul> | <p><b>Cisco IOS-XE Release 16.5.1 and Later Releases</b></p> <p>Cisco cBR-8 CCAP Line Cards:</p> <ul style="list-style-type: none"> <li>• PID—CBR-LC-8D30-16U30</li> <li>• PID—CBR-LC-8D31-16U30</li> <li>• PID—CBR-RF-PIC</li> <li>• PID—CBR-RF-PROT-PIC</li> <li>• PID—CBR-CCAP-LC-40G</li> <li>• PID—CBR-CCAP-LC-40G-R</li> <li>• PID—CBR-CCAP-LC-G2-R</li> <li>• PID—CBR-SUP-8X10G-PIC</li> <li>• PID—CBR-2X100G-PIC</li> </ul> <p>Digital PICs:</p> <ul style="list-style-type: none"> <li>• PID—CBR-DPIC-8X10G</li> <li>• PID—CBR-DPIC-2X100G</li> </ul> <p>Cisco cBR-8 Downstream PHY Module:</p> <ul style="list-style-type: none"> <li>• PID—CBR-D31-DS-MOD</li> </ul> <p>Cisco cBR-8 Upstream PHY Modules:</p> <ul style="list-style-type: none"> <li>• PID—CBR-D31-US-MOD</li> </ul> |





**Note** Do not use DPICs (8X10G and 2x100G) to forward IP traffic, as it may cause buffer exhaustion, leading to line card reload.

The only allowed traffic on a DPIC interface is DEPI, UEPI, and GCP traffic from the Cisco cBR-8 router to Remote PHY devices. Other traffic such as DHCP, SSH, and UTSC should flow via another router, since DPICs cannot be used for normal routing.

## Restrictions for IPv6 on Cable

### Capability Restrictions

Starting with Cisco IOS XE Dublin 17.12.1, configuring **ipv6 cef distributed** is mandatory and is enabled by default. You cannot disable this command.

### Multicast Restrictions

IPv6 multicast has the following behavior restrictions on the Cisco CMTS routers:

- ICMP redirects are not sent to the originating host if the packet is destined for another CPE behind the same CM. All CPE-to-CPE traffic is processed by the Cisco CMTS router.
- IPv6 multicast forwarding is not supported in Parallel Express Forwarding (PXF), therefore, the IPv6 multicast forwarding performance is limited by the Router Processor (RP).

The following areas of IPv6 multicast are not supported by the Cisco CMTS routers:

- Address family support for Multiprotocol Border Gateway Protocol (MBGP)
- Bidirectional Protocol Independent Multicast (PIM)
- Bootstrap router (BSR)
- DOCSIS 3.0 encrypted multicast
- Explicit tracking of receivers
- IPv6 multicast echo
- Multicast Forwarding Information Base (MFIB) display enhancements
- Multicast use authentication and profile support
- PIM embedded rendezvous point
- Protocol Independent Multicast sparse mode (PIM-SM) accept register feature
- Reverse path forwarding (RPF) flooding of bootstrap router (BSR) packets
- Routable address hello option
- Source Specific Multicast (SSM) mapping for Multicast Listener Device (MLD) version 1 SSM

## QoS Restrictions

In Cisco IOS-XE Release 16.5.1, the following fields are supported for the IPv6 downstream classification:

- IPv6 dest addr
- ipv6 src addr
- IPv6 next header
- IPv6 traffic class



---

**Note** IPv6 flow label field is not supported.

---

The following areas of DOCSIS QoS are not supported by the Cisco CMTS routers:

- Upstream IPv6 Type of Service (ToS) overwrite
- Downstream IPv6 classification



---

**Note** ToS overwrite, DOCSIS classification, and Modular QoS CLI (MQC) on Gigabit Ethernet are supported.

---

## Information About IPv6 on Cable

This section includes the following topics:

### Features Supported

The following features are supported on the Cisco CMTS routers:

- Source verification of IPv6 packets in PXF
- ACL support for PXF
- ToS overwrite
- DOCSIS classification
- Modular QoS CLI (MQC) on Gigabit Ethernet
- IPv6 DOCSIS RP and LC HA and DCC
- MAC tapping of IPv6 packets
- Equal cost route load balancing of IPv6 packets destined to the backhaul
- IPv6 over IPv4 GRE tunnels
- Assignment of different prefixes to CM and CPE
- DHCPv6 over MPLS-VPN
- DHCPv6 relay prefix delegation VRF awareness
- Assignment of multiple IAPDs in a single advertise for each CPE.
- Assignment of multiple IA\_NA and IAPD combinations to multiple CPEs behind a CM.

- The default maximum number of IA\_NA and IAPD combinations for each cable modem is 16, including link-local addresses.
- IPv6 Downstream ToS overwrite.
- DHCPv6 Client Link-Layer Address Option (RFC 6939).
- Voice over IPv6. PacketCable Multimedia needs to be enabled before using this feature. For more information, see [http://www.cisco.com/c/en/us/td/docs/cable/cbr/configuration/guide/b\\_pktcbl\\_pktcblmm/packetcable\\_and\\_packetcable\\_multimedia.html](http://www.cisco.com/c/en/us/td/docs/cable/cbr/configuration/guide/b_pktcbl_pktcblmm/packetcable_and_packetcable_multimedia.html).

## Overview of the DOCSIS 3.0 Network Model Supporting IPv6

Figure below illustrates the network model described by the *DOCSIS 3.0 MAC and Upper Layer Protocols Interface Specification*.

**Figure 30: DOCSIS 3.0 Network Model**

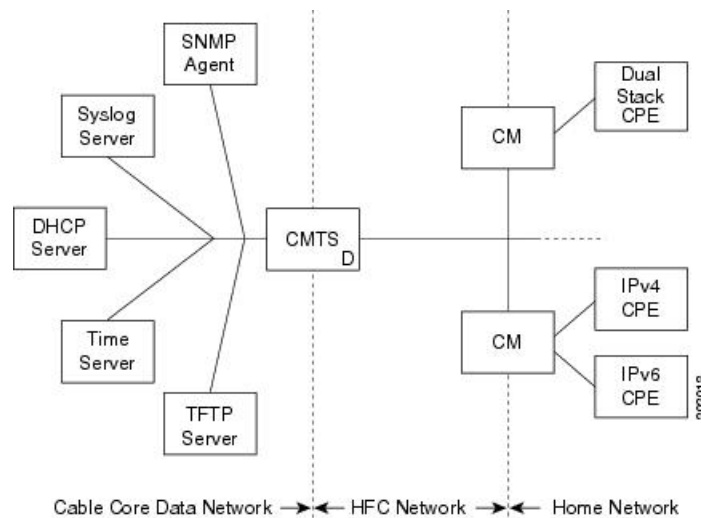

In this model, the different devices support the following functions and services:

- Customer premises equipment (CPE)—Supports IPv4, IPv6, or dual stack operation.



**Note** Cisco cBR routers support CPE devices provisioned for dual stack operation.

- Cable modem (CM)—Functions as a bridging device and supports IPv4, IPv6, or dual stack operation.
- Cable modem termination system (CMTS) router—Works with the CM over the hybrid fiber coaxial cable (HFC) network to provide IPv4 and IPv6 network connectivity to the provisioning servers and the core data network behind the CMTS router.

The CMTS router supports IPv6 address assignment, routing, and forwarding of IPv6 multicast and unicast packets.



---

**Note** The Cisco cBR router supports only a single DHCPv6 IPv6 address per client cable modem or CPE. This restriction also applies to DHCPv6 Prefix Delegation prefixes. The reason for blocking more than one DHCPv6 address or prefix for a client is because the end-to-end network requires Source Address Selection (SAS) and all nodes in the end-to-end network may not support the correct SAS. Moreover, the SAS specification (RFC 3484) is being revised by the IETF to define the correct SAS behavior.

---

- Simple Network Management Protocol (SNMP) agent—Provides management tools to configure and query devices on the network.
- Syslog server—Collects messages from the CM to support its functions.
- Dynamic Host Control Protocol (DHCP) server—The DOCSIS 3.0 network model supports both DHCPv4 and DHCPv6 servers to control the assignment of IP addresses.
- Time server—Provides the current time to the CM.
- Trivial File Transport Protocol (TFTP) server—Provides the CM configuration file.

## Overview of Cable Modem IPv6 Address Provisioning

Prior to cable modem registration with a CMTS router, the CMTS router sends a MAC Domain Descriptor (MDD) message to provide information to the cable modem about its supported IP provisioning mode. You configure the CMTS router provisioning mode using the **cable ip-init** interface configuration command. For more information, see the [Implementing IPv6 Addressing and Basic Connectivity for Cable Interfaces and Bundles, on page 1041](#).

The MDD contains an IP initialization parameters type length value (TLV) that defines the IP version, management and alternate provisioning mode, and pre-registration downstream service ID (DSID) that is used by cable modems that are capable of downstream traffic filtering.

When IPv6 is configured and active, for transmitting multicast DSID carrying IPv6 ND messages within a MAC domain, the CMTS contains the pre-registration DSID TLV encoding (type 5.2) in the MDD message.



---

**Note** The Cisco CMTS routers do not support alternate provisioning mode or pre-registration DSID.

---

To support the MULPIv3.0 I04 or later version of the *DOCSIS 3.0 MAC and Upper Layer Protocols Interface Specification*, the cable modem must attempt IPv6 address acquisition first.

Figure below illustrates the message flow between a cable modem, the CMTS router, and the DHCP server when the cable modem is requesting an IPv6 address.

Figure 31: Message Flow for CM Provisioning of DHCP IPv6 Address Assignment

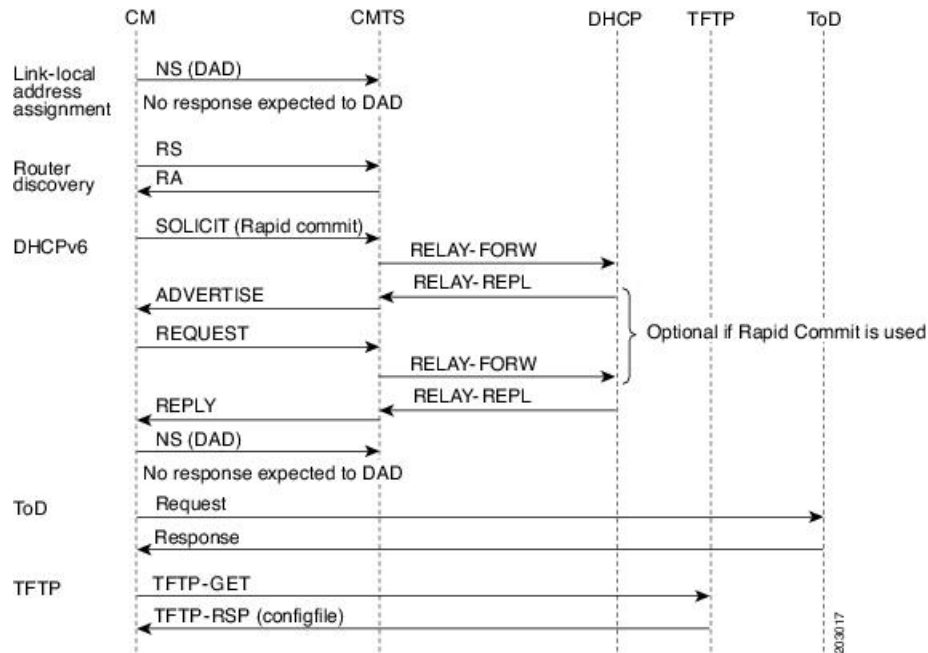

1. Link-local address assignment—The cable modem sends a Neighbor Solicit (NS) message with its link-local address (LLA) to the CMTS router, which starts the duplicate address detection (DAD) process for that LLA. The cable modem expects no response to the NS message.
2. Router discovery—The cable modem listens to the downstream to detect periodical Router Advertise (RA) messages. When an RA message is detected, the cable modem uses the data in the RA message to configure the default route. If an RA is not detected in a specified period, the cable modem sends a Router Solicit (RS) message to find the router on the link (all nodes multicast). The CMTS router responds with a Router Advertise (RA) message with the M and O bits set to 1 to instruct the CM to perform stateful address configuration.



**Note** Cisco CMTS routers do not support SLAAC address assignment.

- DHCPv6—The cable modem sends a DHCPv6 Solicit message to the CMTS router to request an IPv6 address. The CMTS router relays this message to the DHCPv6 servers. The DHCPv6 servers send an Advertise message indicating the server's availability.

If the Rapid-Commit option is not used by the cable modem, then the cable modem responds to the Advertise message of the server with a Request message to select the server that the CMTS router relays to the DHCPv6 server. If the Rapid-Commit option is used, then multiple DHCPv6 servers that could assign different addresses to the same CPE must not be used.

The cable modem starts the DAD process to verify the uniqueness of the IPv6 address that the DHCPv6 server assigns to it.

- TFTP and Time of Day (ToD)—Once the CM establishes IP connectivity, it sends a request to the TFTP server to download a configuration file and requests the current time from the ToD server to complete its boot process.

## Overview of IPv6 Dual Stack CPE Support on the CMTS

Most operating systems (OS) deployed at homes support dual stack operation. Cisco CMTS supports dual stack, which is both IPv4 and IPv6 addressing on the CPE.

## Overview of IPv6 over Subinterfaces

Cisco CMTS supports IPv6 over bundle subinterfaces. To configure IPv6 on bundle subinterfaces, see the [Implementing IPv6 Addressing and Basic Connectivity for Cable Interfaces and Bundles, on page 1041](#) section. For a CMTS bundle configuration example, see the [Example: IPv6 over Subinterfaces, on page 1056](#) section.

To enable IPv6 on subinterfaces, configure IPv6 on bundle subinterfaces and not the bundle. Reset the CMTS after the subinterface is configured.



---

**Note** MPLS VPN over subinterfaces for IPv6 is not supported.

---

## Overview of High Availability on IPv6

Cisco cBR Series routers support IPv6 HA for the Supervisor card.



---

**Note** IPv6 DOCSIS HA and HCCP is supported on the Cisco CMTS routers.

---

The IPv6 HA feature support in Cisco CMTS routers covers the following capabilities:

- DOCSIS PRE HA
- DOCSIS line card HA
- Dynamic Channel Change (DCC)

### DOCSIS PRE HA

The DOCSIS PRE HA has the following behavior restrictions and prerequisites on the Cisco CMTS routers:

- The CMs and CPEs should not go offline after a PRE switchover.
- The data structures of the IPv6 CM and CPE should be synchronized to the standby PRE before the PRE switchover. Both dynamic and bulk synchronization is supported.
- Single stack, dual stack, and APM are supported for the CM.
- Single stack and dual stack provisioning modes are supported on the CPE.
- After a PRE switchover, the IPv6 neighbor entries are rebuilt by Neighbor Discovery (ND) messages on the standby PRE, and the IPv6 routes are rebuilt after converging the routing protocol.

### DOCSIS Line Card HA

The DOCSIS line card HA has the following behavior restrictions and prerequisites on the Cisco CMTS routers:

- The data structures of the IPv6 CM and CPE should be synchronized to the standby line card before the line card switchover. Both dynamic and bulk synchronization is supported.

- The CMs and CPEs should not fall offline after a line card switches over and reverts; the CMs and CPEs should behave the same as before the switchover.
- The DOCSIS line card HA supports both 4+1 and 7+1 redundancy.
- Traffic outages in IPv6 may be longer because traffic recovery occurs only after converging the routing protocol.

## Dynamic Channel Change

The Dynamic Channel Change (DCC) feature is supported on Cisco CMTS routers.



---

**Note** The behavior of the DCC for single stack IPv6 CM and CPE, or dual stack CM and CPE is the same as that of a single stack IPv4 CM and CPE.

---

The IPv6 and IPv4 DCC functionality has the following behavior restrictions and prerequisites on the Cisco CMTS routers:

### Narrowband Cable Modem

- If the source and destination MAC domains of the CM are on the same line card, DCC initialization techniques 0, 1, 2, 3, and 4 are used to move the CM and its associated CPE from one upstream or downstream to another; or move the CM and CPE from one upstream and downstream combination to another.
- If the source and destination MAC domains of the CM are on different line cards, you can use only the DCC initialization technique 0 to move the CM and its associated CPE across line cards.

### Wideband Cable Modem

- If the source and destination MAC domains of the CM are on the same line card, DCC initialization techniques 0, 1, 2, 3, and 4 are used to move the CM and its associated CPE from one upstream to another.
- If the primary downstream of a CM is changed after DCC, you can use only the DCC initialization technique 0 to move the CM and its associated CPE across line cards.

## Overview of IPv6 VPN over MPLS

The Multiprotocol Label Switching (MPLS) VPN feature represents an implementation of the provider edge (PE) based VPN model. This document describes the IPv6 VPN over MPLS (6VPE) feature.

The 6VPE feature allows Service Providers to provide an IPv6 VPN service that does not require an upgrade or reconfiguration of the PE routers in the IPv4 MPLS Core. The resulting IPv6 VPN service has a configuration and operation which is virtually identical to the current IPv4 VPN service.

In principle, there is no difference between IPv4 and IPv6 VPNs. In both IPv4 and IPv6, the multiprotocol BGP is the core of the MPLS VPN for IPv6 (VPNv6) architecture. It is used to distribute IPv6 routes over the service provider backbone using the same procedures to work with overlapping addresses, redistribution policies, and scalability issues.

Figure below illustrates the 6PE/6VPE reference architecture diagram.

Figure 32: 6PE/6VPE Reference Architecture

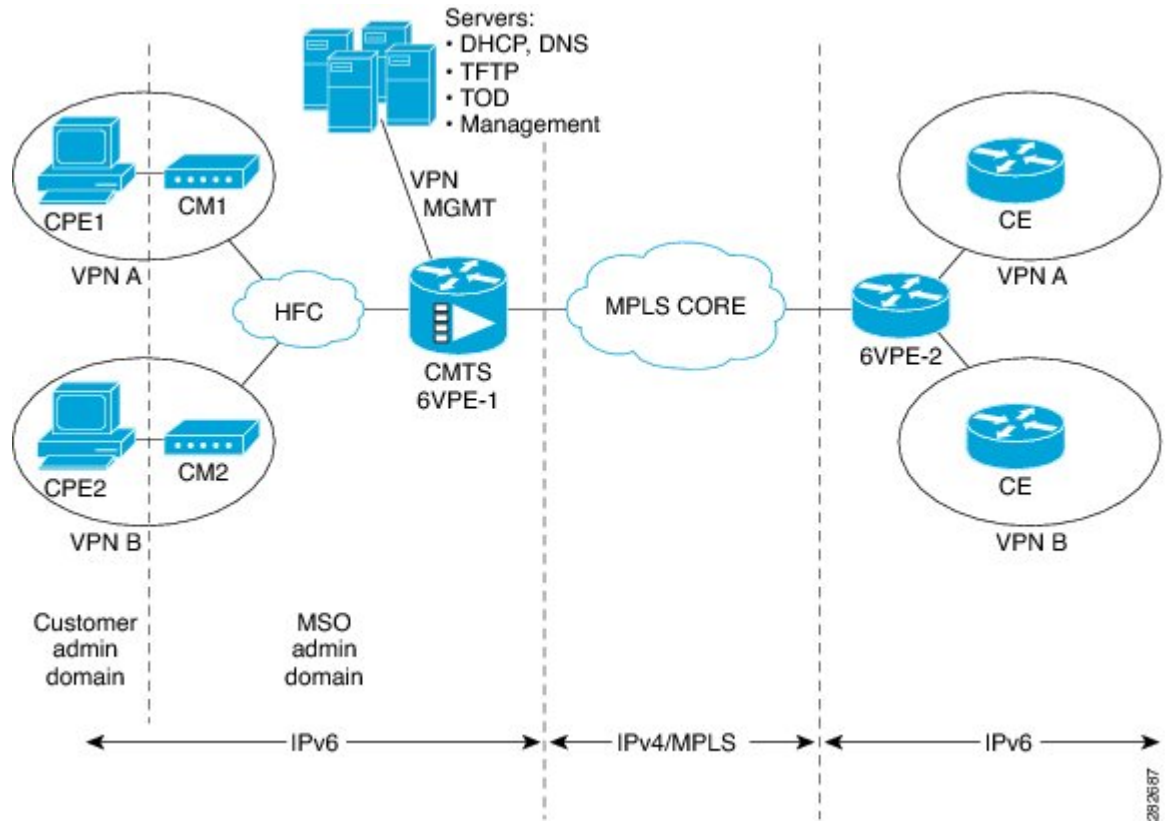

## Cable Monitor

The Cable Monitor and Intercept features for Cisco CMTS routers provide a software solution for monitoring and intercepting traffic coming from a cable network. These features give service providers Lawful Intercept capabilities.

For more information, see the Cable Monitor and Intercept Features for the Cisco CMTS Routers guide.

## Overview of IPv6 CPE Router Support on the Cisco CMTS

The IPv6 CPE router support is provided on the Cisco CMTS. The IPv6 CPE router is a node primarily for home or small office use that connects the end-user network to a service provider network. It is also referred to as the home router.

The IPv6 CPE router is responsible for implementing IPv6 routing; that is, the IPv6 CPE router looks up the IPv6 destination address in its routing table and decides to which interface the packet should be sent.

The IPv6 CPE router performs the following functions:

- Provisions its WAN interface automatically.
- Acquires IP address space for provisioning of its LAN interfaces.
- Fetches other configuration information from the service provider network.



Figure below illustrates the CPE router reference architecture diagram between the CPE router, the CMTS, and the DHCPv6 server (CNR) when the CM is requesting an IPv6 address.

**Figure 33: IPv6 CPE Router Reference Architecture**

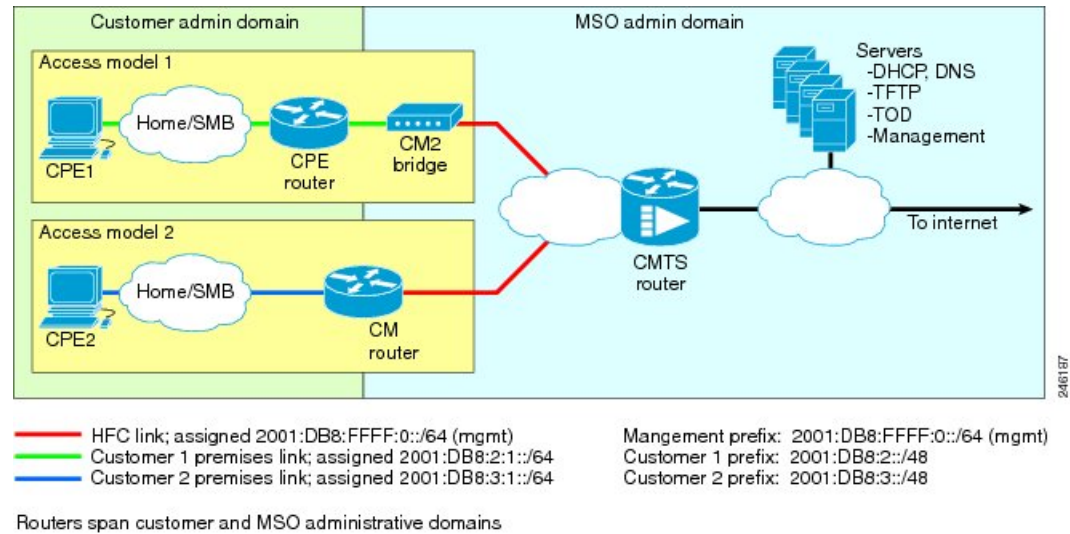

As part of the IPv6 CPE Router Support feature, the following enhancements are introduced:

- Support to IPv6 router devices.
- IPv6 Prefix Delegation (PD) High Availability.
- Prefix awareness support in IPv6 cable source-verify, Cable DOCSIS filters code, and packet intercepts.

## Support for IPv6 Prefix Stability on the CMTS

IPv6 prefix stability is supported on the Cisco CMTS as specified in DOCSIS 3.0 MULPI CM-SP-MULPIv3.0-115-110210 standard. The IPv6 prefix stability allows an IPv6 home router to move from one Cisco CMTS to another while retaining the same prefix.

The multiple service operators (MSOs) can use this feature to allow their business customers (with IPv6 routers) to retain the same IPv6 prefix during a node split.

## Configurable DHCPv6 Relay Address

The DHCPv6 Cisco IOS relay agent on the Cisco CMTS router sends relay-forward messages from a source address to all configured relay destinations. The source address is either an IPv6 address provisioned on the network interface or a Cisco CMTS WAN IPv6 address. The relay destination can be a unicast address of a server, another relay agent, or a multicast address. The relay-forward messages contain specific DHCPv6 link-addresses.

A DHCP relay agent is used to relay messages between the client and server. A client locates a DHCP server using a reserved, link-scoped multicast address.

Use the **cable ipv6 dhcp-insert hostname** command to configure the Cisco cBR-8 routers for inserting descriptors into DHCPv6 packets and to insert the specific hostname.

### DHCPv6 Client Link-Layer Address Option (RFC 6939)

Cisco IOS-XE Releases support DHCPv6 Client Link-Layer Address Option (RFC 6939). It defines an optional mechanism and the related DHCPv6 option to allow first-hop DHCPv6 relay agents (relay agents that are connected to the same link as the client) to provide the client's link-layer address in the DHCPv6 messages being sent towards the server.

The format of the DHCPv6 Client Link-Layer address option is shown below.

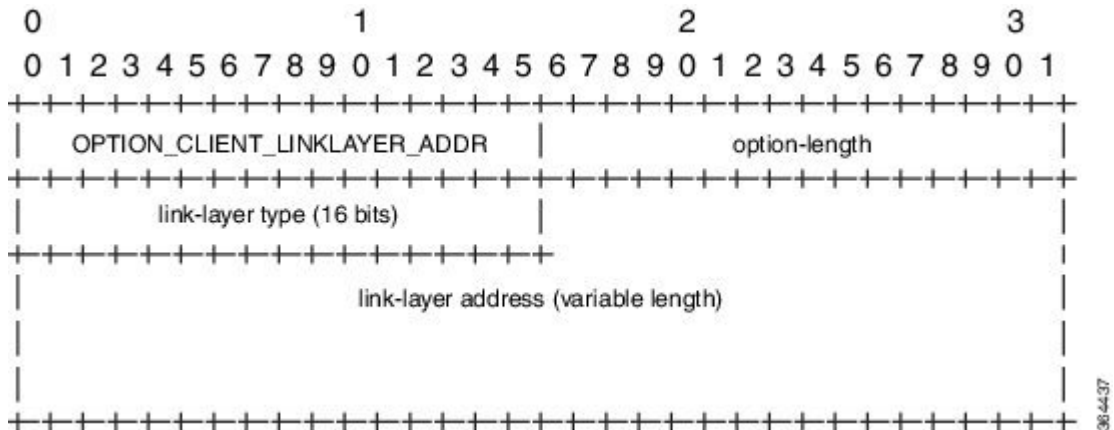

| Name               | Description                                                                                                                  |
|--------------------|------------------------------------------------------------------------------------------------------------------------------|
| option-code        | OPTION_CLIENT_LINKLAYER_ADDR (79)                                                                                            |
| option-length      | 2 + length of MAC address                                                                                                    |
| link-layer type    | CPE or CM MAC address type. The link-layer type MUST be a valid hardware type assigned by the IANA, as described in RFC0826. |
| link-layer address | MAC address of the CPE or CM.                                                                                                |



**Note** RFC6939 is enabled by default. It can not be enabled/disabled by any CLI command.

To configure DHCPv6 Relay Address on the Cisco CMTS bundle subinterfaces, see the [Configuring DHCPv6 Relay Agent, on page 1052](#) section.

For more information about the DHCPv6 client, server, and relay functions, see the *Implementing DHCP for IPv6* chapter in the [IPv6 Implementation Guide, Cisco IOS XE Release 3S](#).

## Support for Multiple IAPDs in a Single Advertise

Assignment of multiple IA\_NA and IAPD to CPEs behind a CM is supported on Cisco CMTS routers. This feature includes support for link-local addresses and IA\_NA and IAPD. However, a CM can be assigned only one IA\_NA. This IA\_NA can be either static or DHCP-assigned.

The CPEs behind the CM can request for multiple DHCPv6 IA\_NAs and IAPDs. Each CPE is assigned multiple IA\_NAs and IAPDs in a single Advertise/Reply message. Each CPE request for IA\_NA and IAPD is treated as a separate Advertise/Reply message.

## IPv6 Neighbor Discovery Gleaning

The IPv6 Neighbor Discovery (ND) Gleaning feature enables Cisco CMTS routers to automatically recover lost IPv6 CPE addresses and update the CPE records in the Cisco CMTS subscriber database. The Cisco CMTS router gleans only the solicited neighbor advertise (NA) messages transmitted in the upstream direction. IPv6 ND gleaning is similar to Address Resolution Protocol (ARP) gleaning for IPv4 CPE recovery.

The IPv6 ND Gleaning feature is configured by default on Cisco CMTS routers. To disable this feature, use the **no** form of the **cable nd** command in bundle interface configuration mode. The **cable nd** command adds a CPE (host behind a cable modem) to the Cisco CMTS subscriber database. This command does not impact the IPv6 ND protocol operation on the router.



---

**Note** The IPv6 ND Gleaning feature does not support gleaning of NA messages transmitted in the downstream direction.

---

## How to Configure IPv6 on Cable

This section includes the following tasks:

### Configuring IPv6 Switching Services

The CMTS routers support forwarding of unicast and multicast IPv6 traffic using either Cisco Express Forwarding for IPv6 (CEFv6) or distributed CEFv6 (dCEFv6):

- CEFv6—All CMTS platforms
- dCEFv6—Cisco uBR10012 universal broadband router only

The CMTS routers also support Unicast Reverse Path Forwarding (RPF), as long as you enable Cisco Express Forwarding switching or distributed Cisco Express Forwarding switching globally on the router. There is no need to configure the input interface for Cisco Express Forwarding switching. As long as Cisco Express Forwarding is running on the router, individual interfaces can be configured with other switching modes.

To configure forwarding of IPv6 traffic using Cisco Express Forwarding or distributed Cisco Express Forwarding (supported on the Cisco uBR10012 universal broadband router only) on the CMTS routers, you must configure forwarding of IPv6 unicast datagrams using the **ipv6 unicast-routing** global configuration command, and you must configure an IPv6 address on the bundle interface using the **ipv6 address** command.

The **show ipv6 cef platform** command is supported on the Cisco CMTS platform. You can use the **show ipv6 cef platform** command for debugging purposes.

#### Before you begin

- You must enable Cisco Express Forwarding for IPv4 globally on the router by using the **ip cef** or **ip cef distributed** command before configuring Cisco Express Forwarding v6 or distributed Cisco Express Forwarding v6.



**Note** The **ip cef** command is enabled by default on all Cisco CMTS routers. Therefore, you only must configure the command if it has been disabled. However, you must explicitly configure the **ip cef distributed** command on a Cisco uBR10012 universal broadband router if you want to run distributed CEF switching services for IPv4 or IPv6.

- You must configure forwarding of IPv6 unicast datagrams using the **ipv6 unicast-routing** global configuration command.
- You must configure IPv6 addressing on the cable bundle interface.
- CEF switching is required for Unicast RPF to work.

**Procedure**

|               | Command or Action                                                                                                                                                                                                             | Purpose                                                                                                                                                                                                                                                      |
|---------------|-------------------------------------------------------------------------------------------------------------------------------------------------------------------------------------------------------------------------------|--------------------------------------------------------------------------------------------------------------------------------------------------------------------------------------------------------------------------------------------------------------|
| <b>Step 1</b> | <b>enable</b><br><b>Example:</b><br>Router> enable                                                                                                                                                                            | Enables privileged EXEC mode. Enter your password if prompted.                                                                                                                                                                                               |
| <b>Step 2</b> | <b>configure terminal</b><br><b>Example:</b><br>Router# configure terminal                                                                                                                                                    | Enters global configuration mode.                                                                                                                                                                                                                            |
| <b>Step 3</b> | Do one of the following: <ul style="list-style-type: none"> <li>• <b>ip cef</b></li> <li>• <b>ip cef distributed</b></li> </ul> <b>Example:</b><br>Router(config)# ip cef<br>or<br>Router(config)# ip cef distributed         | Enables Cisco Express Forwarding.<br>or<br>Enables distributed Cisco Express Forwarding for IPv4 datagrams.<br><b>Note</b> For CMTS routers, distributed Cisco Express Forwarding is supported only on a Cisco uBR10012 universal broadband router.          |
| <b>Step 4</b> | Do one of the following: <ul style="list-style-type: none"> <li>• <b>ipv6 cef</b></li> <li>• <b>ipv6 cef distributed</b></li> </ul> <b>Example:</b><br>Router(config)# ipv6 cef<br>or<br>Router(config)# ipv6 cef distributed | Enables Cisco Express Forwarding v6.<br>or<br>Enables distributed Cisco Express Forwarding v6 for IPv6 datagrams.<br><b>Note</b> For CMTS routers, distributed Cisco Express Forwarding v6 is supported only on a Cisco uBR10012 universal broadband router. |

|        | Command or Action                                                                             | Purpose                                           |
|--------|-----------------------------------------------------------------------------------------------|---------------------------------------------------|
| Step 5 | <b>ipv6 unicast-routing</b><br><b>Example:</b><br>Router(config)# <b>ipv6 unicast-routing</b> | Enables the forwarding of IPv6 unicast datagrams. |

#### What to do next

- (Optional) Enable IPv6 multicast routing using the **ipv6 multicast-routing** command in global configuration mode and configure other multicast features.

## Implementing IPv6 Addressing and Basic Connectivity for Cable Interfaces and Bundles

### Configuring the Cable Virtual Bundle Interface

The only required IPv6 configuration on a cable line card interface is the IP provisioning mode. The remainder of the IPv6 features are configured at the virtual bundle interface, which is then associated with a particular cable line card interface to establish its configuration.

Most of the IPv6 features that are supported in interface configuration mode (both cable-specific as well as platform-independent IPv6 features) are configured at a cable bundle interface.

The Cisco CMTS routers support IPv6 routing on the bundle interface and map both IPv6 unicast and multicast addresses into the cable bundle forwarding table, for packet forwarding.

Each bundle interface has a unique link-local address (LLA) to support link-local traffic when IPv6 is enabled. Cisco CMTS routers can support a maximum of 40 active bundle interfaces, which also translates to a maximum of 40 active IPv6-enabled bundle interfaces.

IPv6 commands can be configured on multiple bundle subinterfaces.

#### Before you begin

The **cable ipv6 source-verify** and **cable nd** commands are not compatible with each other in Cisco IOS release 12.2(33)SCE and later. You must disable IPv6 ND gleaning using the **no** form of the **cable nd** command before using the **cable ipv6 source-verify** command to ensure that only DHCPv6 and SAV-based CPEs can send traffic on the router.



---

**Restriction** All multicast traffic is flooded onto bundle member interfaces.

---

#### Procedure

|        | Command or Action                | Purpose                                                        |
|--------|----------------------------------|----------------------------------------------------------------|
| Step 1 | <b>enable</b><br><b>Example:</b> | Enables privileged EXEC mode. Enter your password if prompted. |

|               | Command or Action                                                                                                                               | Purpose                                                                                                                                                                                                                                                                                                                                                                                                                |
|---------------|-------------------------------------------------------------------------------------------------------------------------------------------------|------------------------------------------------------------------------------------------------------------------------------------------------------------------------------------------------------------------------------------------------------------------------------------------------------------------------------------------------------------------------------------------------------------------------|
|               | Router> enable                                                                                                                                  |                                                                                                                                                                                                                                                                                                                                                                                                                        |
| <b>Step 2</b> | <b>configure terminal</b><br><b>Example:</b><br>Router# configure terminal                                                                      | Enters global configuration mode.                                                                                                                                                                                                                                                                                                                                                                                      |
| <b>Step 3</b> | <b>interface bundle n</b><br><b>Example:</b><br>Router(config)# interface bundle 1                                                              | Specifies the cable bundle interface and enters interface configuration mode, where <i>n</i> specifies the number of the bundle interface.                                                                                                                                                                                                                                                                             |
| <b>Step 4</b> | <b>ipv6 address</b> <i>ipv6-prefix /prefix-length [eui-64]</i><br><b>Example:</b><br>Router(config-if)# ipv6 address 2001:DB8::/32 eui-64       | Specifies an IPv6 network assigned to the interface and enables IPv6 processing on the interface. The <b>ipv6 address</b> <i>eui-64</i> command configures site-local and global IPv6 addresses with an interface identifier (ID) in the low-order 64 bits of the IPv6 address. You need to specify only the 64-bit network prefix for the address; the last 64 bits are automatically computed from the interface ID. |
| <b>Step 5</b> | <b>ipv6 address</b> <i>ipv6-prefix /prefix-length link-local</i><br><b>Example:</b><br>Router(config-if)# ipv6 address 2001:DB8::/32 link-local | (Optional) Specifies an IPv6 address assigned to the interface and enables IPv6 processing on the interface. The <b>ipv6 address link-local</b> command configures a link-local address on the interface that is used instead of the link-local address that is automatically configured, when IPv6 is enabled on the interface (using the <b>ipv6 enable</b> command).                                                |
| <b>Step 6</b> | <b>ipv6 enable</b><br><b>Example:</b><br>Router(config-if)# ipv6 enable                                                                         | Automatically configures an IPv6 link-local address on the interface while also enabling the interface for IPv6 processing. The link-local address can be used only to communicate with nodes on the same link.                                                                                                                                                                                                        |
| <b>Step 7</b> | <b>cable ipv6 source-verify</b><br><b>Example:</b><br>Router(config-if)# cable ipv6 source-verify                                               | (Optional) Enables source verification of MAC address-MD-SID-IPv6 address binding packets received by a cable interface upstream on Cisco CMTS routers.                                                                                                                                                                                                                                                                |

**What to do next**

- Configure the desired platform-independent IPv6 features on the bundle interface, such as Neighbor Discovery and DHCPv6 features.
- Configure the IP provisioning mode and bundle on the cable interface.

**Configuring the IP Provisioning Mode and Bundle on the Cable Interface**

The CMTS routers allow you to configure cable interfaces to support cable modems provisioned for both IPv4 and IPv6 addressing support (known as “dual stack”), only IPv4 addressing, or only IPv6 addressing.

Prior to cable modem registration, the CMTS router sends its supported provisioning mode to the cable modem in the MDD message.

In addition to configuring the provisioning mode on the cable interface, you must also associate the cable interface with a cable bundle. You perform most of the other IPv6 feature configuration at the bundle interface.



---

**Note** This section describes only the commands associated with establishing IPv6 support on a CMTS router. Other cable interface commands that apply but are optional are not shown, such as to configure upstream and downstream features.

---

### Before you begin

Configuration of a bundle interface is required.

---

#### Step 1 **enable**

**Example:**

```
Router> enable
```

Enables privileged EXEC mode. Enter your password if prompted.

#### Step 2 **configure terminal**

**Example:**

```
Router# configure terminal
```

Enters global configuration mode.

#### Step 3 **interface cable** {slot / port | slot / subslot /port }

**Example:**

```
Router(config)# interface cable 5/0/1
```

Specifies the cable interface line card, where:

The valid values for these arguments are dependent on your CMTS router and cable interface line card. Refer to the hardware documentation for your router chassis and cable interface line card for supported slot and port numbering.

#### Step 4 **cable ip-init** {apm | dual-stack | ipv4 | ipv6}

**Example:**

```
Router(config-if)# cable ip-init ipv6
```

Specifies the IP provisioning mode supported by the cable interface, where:

#### Step 5 **cable bundle***n*

**Example:**

```
Router(config)# cable bundle 1
```

Associates the cable interface with a configured virtual bundle interface, where  $n$  specifies the number of the bundle interface.

---

### What to do next

- Proceed to configuring any other cable interface features that you want to support, such as upstream and downstream features. For more information about the other cable interface features, refer to the *Cisco IOS CMTS Cable Software Configuration Guide*.
- Proceed to configure other optional IPv6 cable features.

## Enabling MDD with Pre-Registration DSID

When only IPv4 is configured and active, where the IP provisioning mode is IPv4, for Cable Modems to come online, the pre-registration DSID (TLV 5.2) is required in the MAC Domain Descriptor (MDD) message. To enable this pre-registration DSID, use the following command.

By default, this command is disabled.

```
Router#configure terminal
Router(config)#cable ipv4-prereg-dsid
Router(config)#end
```

## Configuring IPv6 Cable Filter Groups

The Cisco CMTS router supports IPv6 cable filter group capability with IPv6 filter options.

## Configuring IPv6 Cable Filter Groups

The Cisco CMTS router supports IPv6 cable filter group capability with IPv6 filter options.

## Cable Filter Groups and the DOCSIS Subscriber Management MIB

Cable subscriber management is a DOCSIS 1.1 specification, which can be established using the following configuration methods:

- CMTS router configuration (via CLI)
- SNMP configuration
- DOCSIS 1.1 configuration file (TLVs 35, 36, and 37)

This section describes the IPv6 cable filter group feature support of the packet filtering portion of the DOCSIS Subscriber Management MIB (DOCS-SUBMGMT-MIB) using configuration commands on the CMTS routers. This IPv6 cable filter group support extends filter classifiers with IPv6 addressing options for CM and CPE traffic, but is independent of DOCSIS IPv6 classifiers, which are used to match packets to service flows.

Configuration of IPv6 cable filter groups on the CMTS routers is supported according to the following guidelines:

- A cable filter group consists of a set of **cable filter group** commands that share the same group ID.
- Separate indexes can be used to define different sets of filters for the same group ID. This can be used to define both IPv4 and IPv6 filters to the same filter group.
- CMs can be associated with one upstream and one downstream filter group.



- Upstream traffic—All traffic coming from CMs is evaluated against the assigned upstream filter group that is configured by the **cable submgmt default filter-group cm upstream** command.
- Downstream traffic—All traffic going to CMs is evaluated against the assigned downstream filter group that is configured by the **cable submgmt default filter-group cm downstream** command.
- CPEs can be associated with one upstream and one downstream filter group.
  - Upstream traffic—All traffic coming from CPEs is evaluated against the assigned upstream filter group that is configured by the **cable submgmt default filter-group cpe upstream** command.
  - Downstream traffic—All traffic going to CPEs is evaluated against the assigned downstream filter group that is configured by the **cable submgmt default filter-group cpe downstream** command.



**Note** Because TLVs 35, 36, and 37 do not apply to DOCSIS 1.0 CM configuration files, the only way to enable cable subscriber management for a DOCSIS 1.0 CM is to configure it explicitly on the Cisco CMTS router and activate it by using the **cable submgmt default active** global configuration command.

### Before you begin

You must create the cable filter group before you assign it to a CM or CPE upstream or downstream.



### Restriction

- Chained IPv6 headers are not supported.
- An individual filter group index cannot be configured to support both IPv4 and IPv6 versions at the same time. If you need to support IPv4 and IPv6 filters for the same filter group, then you must use a separate index number with the same filter group ID, and configure one index as **ip-version ipv4**, and the other index as **ip-version ipv6**.
- Only a single upstream and a single downstream filter group can be assigned for CM traffic.
- Only a single upstream and a single downstream filter group can be assigned to CPEs attached to a CM such that all CPEs behind a CM share a common filter group.
- For the filter group to work for CMs, a CM must re-register after the CMTS router is configured for the filter group.
- If parallel eXpress forwarding (PXF) is configured on the Cisco uBR10012 router, either the **cable filter group** commands or the interface ACL (**ip access-list**) command can be configured.
- If you do not provision TLVs 35, 36, and 37 in the DOCSIS CM configuration file, then you must activate the functionality by specifying the **cable submgmt default active** global configuration command on the CMTS router.

### Procedure

|        | Command or Action                                  | Purpose                                                        |
|--------|----------------------------------------------------|----------------------------------------------------------------|
| Step 1 | <b>enable</b><br><b>Example:</b><br>Router> enable | Enables privileged EXEC mode. Enter your password if prompted. |

|               | Command or Action                                                                                                                                                                                                           | Purpose                                                                                                                                                                                                                                                                                                                                                                                          |
|---------------|-----------------------------------------------------------------------------------------------------------------------------------------------------------------------------------------------------------------------------|--------------------------------------------------------------------------------------------------------------------------------------------------------------------------------------------------------------------------------------------------------------------------------------------------------------------------------------------------------------------------------------------------|
| <b>Step 2</b> | <b>configure terminal</b><br><b>Example:</b><br><pre>Router# configure terminal</pre>                                                                                                                                       | Enters global configuration mode.                                                                                                                                                                                                                                                                                                                                                                |
| <b>Step 3</b> | <b>cable filter group</b> <i>group-id</i><br><b>index</b> <i>index-num</i> <b>dest-port</b> <i>port-num</i><br><b>Example:</b><br><pre>Router(config)# cable filter group 1 index 1 dest-port 69</pre>                      | (Optional) Specifies the TCP/UDP destination port number that should be matched. The valid range is from 0 to 65535. The default value matches all TCP/UDP port numbers (IPv4 and IPv6 filters).                                                                                                                                                                                                 |
| <b>Step 4</b> | <b>cable filter group</b> <i>group-id</i> <b>index</b> <i>index-num</i> <b>ip-proto</b> <i>proto-type</i><br><b>Example:</b><br><pre>Router(config)# cable filter group 1 index 1 ip-proto 17</pre>                         | (Optional) Specifies the IP protocol type number that should be matched. The valid range is from 0 to 256, with a default value of 256 that matches all protocols (IPv4 and IPv6 filters).<br><br>Some commonly used values are:                                                                                                                                                                 |
| <b>Step 5</b> | <b>cable filter group</b> <i>group-id</i> <b>index</b> <i>index-num</i> <b>ip-tos</b> <i>tos-mask</i> <i>tos-value</i><br><b>Example:</b><br><pre>Router(config)# cable filter group 1 index 1 ip-tos 0xff 0x80</pre>       | (Optional) Specifies a ToS mask and value to be matched (IPv4 and IPv6 filters):<br><br>The <i>tos-mask</i> is logically ANDed with the <i>tos-value</i> and compared to the result of ANDing the <i>tos-mask</i> with the actual ToS value of the packet. The filter considers it a match if the two values are the same.<br><br>The default values for both parameters matches all ToS values. |
| <b>Step 6</b> | <b>cable filter group</b> <i>group-id</i> <b>index</b> <i>index-num</i> <b>ip-version</b> <i>ipv6</i><br><b>Example:</b><br><pre>Router(config)# cable filter group 1 index 1 ip-version ipv6</pre>                         | Specifies that this filter group is an IPv6 filter group.                                                                                                                                                                                                                                                                                                                                        |
| <b>Step 7</b> | <b>cable filter group</b> <i>group-id</i> <b>index</b> <i>index-num</i> <b>match-action</b> { <i>accept</i>   <i>drop</i> }<br><b>Example:</b><br><pre>Router(config)# cable filter group 1 index 1 match-action drop</pre> | (Optional) Specifies the action that should be taken for packets that match this filter (IPv4 and IPv6 filters):                                                                                                                                                                                                                                                                                 |
| <b>Step 8</b> | <b>cable filter group</b> <i>group-id</i> <b>index</b> <i>index-num</i> <b>src-port</b> <i>port-num</i><br><b>Example:</b><br><pre>Router(config)# cable filter group 1 index 1 src-port 50</pre>                           | (Optional) Specifies the TCP/UDP source port number that should be matched. The valid range is from 0 to 65535. The default value matches all TCP/UDP port numbers (IPv4 and IPv6 filters).                                                                                                                                                                                                      |

|         | Command or Action                                                                                                                                                                                                                      | Purpose                                                                                                                                                                                                                              |
|---------|----------------------------------------------------------------------------------------------------------------------------------------------------------------------------------------------------------------------------------------|--------------------------------------------------------------------------------------------------------------------------------------------------------------------------------------------------------------------------------------|
| Step 9  | <p><b>cable filter group</b> <i>group-id</i> <b>index</b> <i>index-num</i> <b>status</b> {<b>active</b>   <b>inactive</b>}</p> <p><b>Example:</b></p> <pre>Router(config)# cable filter group 1 index 1 status inactive</pre>          | <p>(Optional) Enables or disables the filter (IPv4 and IPv6 filters):</p> <p><b>Note</b> You must create a filter group using at least one of the other options before you can use this command to enable or disable the filter.</p> |
| Step 10 | <p><b>cable filter group</b> <i>group-id</i> <b>index</b> <i>index-num</i> <b>tcp-flags</b> <i>flags-mask</i> <i>flags-value</i></p> <p><b>Example:</b></p> <pre>Router(config)# cable filter group 1 index 1 tcp-flags 0 0</pre>      | <p>(Optional) Specifies the TCP flag mask and value to be matched (IPv4 and IPv6 filters):</p>                                                                                                                                       |
| Step 11 | <p><b>cable filter group</b> <i>group-id</i> <b>index</b> <i>index-num</i> <b>v6-dest-address</b> <i>ipv6-address</i></p> <p><b>Example:</b></p> <pre>Router(config)# cable filter group 1 index 1 v6-dest-address 2001:DB8::/32</pre> | <p>(Optional) Specifies the IPv6 destination address that should be matched using the format X:X:X:X::X (IPv6 filters only).</p>                                                                                                     |
| Step 12 | <p><b>cable filter group</b> <i>group-id</i> <b>index</b> <i>index-num</i> <b>v6-dest-pfxlen</b> <i>prefix-length</i></p> <p><b>Example:</b></p> <pre>Router(config)# cable filter group 1 index 1 v6-dest-pfxlen 64</pre>             | <p>(Optional) Specifies the length of the network portion of the IPv6 destination address. The valid range is from 0 to 128.</p>                                                                                                     |
| Step 13 | <p><b>cable filter group</b> <i>group-id</i> <b>index</b> <i>index-num</i> <b>v6-src-address</b> <i>ipv6-address</i></p> <p><b>Example:</b></p> <pre>Router(config)# cable filter group 1 index 1 v6-src-address 2001:DB8::/32</pre>   | <p>(Optional) Specifies the IPv6 source address that should be matched using the format X:X:X:X::X (IPv6 filters only).</p>                                                                                                          |
| Step 14 | <p><b>cable filter group</b> <i>group-id</i> <b>index</b> <i>index-num</i> <b>v6-src-pfxlen</b> <i>prefix-length</i></p> <p><b>Example:</b></p> <pre>Router(config)# cable filter group 1 index 1 v6-src-pfxlen 48</pre>               | <p>(Optional) Specifies the length of the network portion of the IPv6 source address. The valid range is from 0 to 128 (IPv6 filters only).</p>                                                                                      |
| Step 15 | <p><b>cable submgmt default filter-group</b> {<b>cm</b>   <b>cpe</b>} {<b>downstream</b>   <b>upstream</b>} <i>group-id</i></p> <p><b>Example:</b></p> <pre>Router(config)# cable submgmt default filter-group cm upstream 1</pre>     | <p>Applies a defined filter group (by specifying its <i>group-id</i>) to either a CM or its CPE devices, for downstream or upstream traffic.</p>                                                                                     |

|                | Command or Action                                                                                             | Purpose                                                                                                                                                                                                                                      |
|----------------|---------------------------------------------------------------------------------------------------------------|----------------------------------------------------------------------------------------------------------------------------------------------------------------------------------------------------------------------------------------------|
| <b>Step 16</b> | <b>cable submgmt default active</b><br><b>Example:</b><br>Router(config)# <b>cable submgmt default active</b> | (Required if you do not provision TLVs 35, 36, and 37 in the DOCSIS 1.1 CM configuration file)<br>Enables filters and allows the CMTS to manage the CPE devices for a particular CM (sets the docsSubMgtCpeActiveDefault attribute to TRUE). |

### Example

The following example shows how to create an IPv6 filter group with ID 254 and an index number of 128. The **ip-version ipv6** keywords must be configured to create the IPv6 filter group; otherwise, the default is an IPv4 filter group:

```
configure terminal
cable filter group 254
  index 128 v6-src-address 2001:DB8::/32
cable filter group 254
  index 128 v6-src-pfxlen 48
cable filter group 254
  index 128 v6-dest-address 2001:DB8::/32
cable filter group 254
  index 128 v6-dest-pfxlen 64
cable filter group 254
  index 128 ip-version ipv6
cable filter group 254
  index 128 match-action drop
cable submgmt default filter-group cm upstream 254
```

This group filters CM upstream traffic and drops any packets with an IPv6 source address of 2001:33::20B:BFFF:FEA9:741F (with network prefix of 128) destined for an IPv6 address of 2001:DB8::/32 (with network prefix of 128).

All of the **cable filter group** commands are associated by their group ID of 254 (and index of 128), and the **cable submgmt default filter-group** command applies the corresponding filter group ID of 254 to CM upstream traffic.

To monitor your cable filter group configuration, use forms of the **show cable filter** command as shown in the following examples. In these output examples, the output from the **show cable filter**, **show cable filter group 254**, and **show cable filter group 254 index 128** commands all display the same information because there is currently only a single filter group and index defined.



**Note** The “Use Verbose” string appears in the output area of the SrcAddr/mask and DestAddr/Mask fields suggesting use of the **show cable filter group verbose** form of the command to display the complete IPv6 address.

```
Router# show cable filter
Filter      SrcAddr/Mask      DestAddr/Mask      Prot ToS  SPort DPort TCP  Action Status
Grp Id v6                                     Flags
254 128Y Use Verbose
          Use Verbose
                                drop  active
```

```

Router# show cable filter group 254
Filter   SrcAddr/Mask   DestAddr/Mask   Prot ToS   SPort DPort TCP   Action Status
Grp Id v6                                     Flags
254 128Y Use Verbose       Use Verbose
Router# show cable filter group 254 index 128
Filter   SrcAddr/Mask   DestAddr/Mask   Prot ToS   SPort DPort TCP   Action Status
Grp Id v6                                     Flags
254 128Y Use Verbose       Use Verbose
Router# show cable filter group 254 index 128 verbose
Filter Group           : 254
Filter Index           : 128
Filter Version         : IPv6
Matches                : 0
  Source IPv6 address  : 2001:DB8::/32
  Destination IPv6 address : 2001:DB8::/32
  Match action         : drop
  Status               : active

```

## Troubleshooting Tips

You should configure the **cable filter group** commands prior to applying a filter group using the **cable submgmt default filter-group** command. Failure to do so results in the following message, and an association to a filter group that is undefined:

```

Router(config)# cable submgmt default filter-group cm upstream 100
Default value set to a nonexistent filter-group 100.

```

## Configuring IPv6 Domain Name Service

Cisco IOS releases support the domain name service (DNS) capability for devices using IPv6 addressing on the Cisco CMTS routers.

DNS simplifies the identification of cable devices by associating a hostname with what can often be a complex 128-bit IPv6 address. The hostname can then be used in place of the IPv6 address within the CMTS router CLI that supports use of hostnames.

There are two separate DNS caches supported on a CMTS router—an IOS DNS cache and a cable-specific DNS cache that stores IPv6 addresses learned by the CMTS router for CMs and CPEs.

In this phase of the IPv6 DNS service on cable, the DNS server is queried for domain name information as needed when you use the **show cable modem domain-name** command. When you use this command, the following actions take place:

1. The CMTS router checks whether CMs are online. If a CM is online, the CMTS router uses the corresponding IPv6 address assigned to the CM and looks up its domain name from the IOS DNS cache.
2. If no match is found, the CMTS router sends a DNS-QUERY message with the IPv6 address of the CM to the DNS server, which tries to resolve the domain name.
3. When the DNS reply is received, the CMTS router stores the domain name in the IOS DNS cache for each IPv6 address.
4. The CMTS router also stores the fully-qualified domain name (FQDN) that is replied by the DNS server in the cable-specific DNS cache.



**Note** Running the **no ip domain lookup** command turns off the DNS resolution.

The following platform-independent Cisco IOS-xe software commands are supported using host names by the CMTS router for IPv6 DNS on cable:

- **connect**
- **ping ipv6**
- **show hosts**
- **telnet**
- **traceroute**

### Before you begin

- A DNS server must be configured.
- You must identify and assign the host names to the IPv6 addresses. If you are using the Cisco DNS server, use the **ip host** global configuration command to map hostnames to IP addresses.
- You must configure the DNS server using the **ip name-server** global configuration command before use of DNS host names (or domains) are available in the supported commands.
- The **show cable modem domain-name** command must be run first on the Route Processor (RP) of the CMTS router before any domain name can be used as part of a cable command.



---

### Restriction

- DNS for cable devices using IPv4 addressing is not supported.
  - Due to column size limitations within the command-line interface (CLI), the domain name display is limited to 32 characters. Therefore, the entire domain name cannot always be seen in CMTS router command output.
  - Only those cable devices where IPv6 address learning takes place are supported, such as acquiring an IPv6 address through DHCPv6 or the IPv6 (ND) process.
  - The cable-specific DNS cache is only updated when you use the **show cable modem domain-name** command on the Route Processor (RP). A DNS-QUERY can only be sent on the RP using this command, therefore the DNS cache cannot update if you use the **show cable modem domain-name** command on a line card console. The output is displayed on the RP only.
  - The cable-specific DNS cache does not store partially qualified domain names, only FQDNs are stored.
  - The cable-specific DNS cache is not associated with the timeouts that apply to the IOS DNS cache. Therefore, a cable-specific DNS cache entry is not removed when an IOS DNS cache timeout occurs for that device. The cable-specific DNS cache is only updated when you use the **show cable modem domain-name** command.
  - The CMTS router supports storage of only one domain name per IPv6 address in the cable-specific DNS cache.
  - Domain names for the link local address are not supported.
  - The **no ip domain-name** command disables DNS lookup.
-

## Procedure

|        | Command or Action                                                                                                                                                                                 | Purpose                                                                                                        |
|--------|---------------------------------------------------------------------------------------------------------------------------------------------------------------------------------------------------|----------------------------------------------------------------------------------------------------------------|
| Step 1 | <b>enable</b><br><b>Example:</b><br>Router> <code>enable</code>                                                                                                                                   | Enables privileged EXEC mode. Enter your password if prompted.                                                 |
| Step 2 | <b>configure terminal</b><br><b>Example:</b><br>Router# <code>configure terminal</code>                                                                                                           | Enters global configuration mode.                                                                              |
| Step 3 | <b>ip name-server</b> [ <i>vrf vrf-name</i> ] <i>server-address1</i> [ <i>server-address2...server-address6</i> ]<br><b>Example:</b><br>Router(config)# <code>ip name-server 2001:DB8::/32</code> | Specifies the address of one or more name servers to use for name and address resolution.                      |
| Step 4 | <b>exit</b><br><b>Example:</b><br>Router(config)# <code>exit</code>                                                                                                                               | Leaves global configuration mode and enters privileged EXEC mode.                                              |
| Step 5 | <b>show cable modem domain-name</b><br><b>Example:</b><br>Router# <code>show cable modem domain-name</code>                                                                                       | Updates the cable-specific DNS cache and displays the domain name for all CMs and the CPE devices behind a CM. |

## Configuring IPv6 Source Verification

Typically, the IPv6 source verification feature is enabled on a cable bundle interface. From there, the cable interface is associated with the virtual bundle interface to acquire its configuration.

When you enable IPv6 source verification on a cable line card interface, the source verification routine verifies the MAC address-MD-SID-IP binding of the packet. If the source verification succeeds, the packet is forwarded. If the verification fails, the packet is dropped.

When a CM is operating as a bridge modem device, then the CMTS router verifies all the IPv6 addresses related to that CM and the CPEs behind that CM.

The **cable ipv6 source-verify** command controls only the source verification of IPv6 packets. For IPv4-based source verification, use the **cable source-verify** command, which also supports different options.

For more information about how to configure IPv6 source verification on a bundle interface, see the [Configuring the Cable Virtual Bundle Interface, on page 1041](#).

### Restrictions

Source verification of IPv6 packets occurs only on packets in the process-switched path of the Route Processor (RP).

## Configuring IPv6 VPN over MPLS

The Cisco CMTS routers support the IPv6 VPN over MPLS (6VPE) feature. Implementing this feature includes the following configuration tasks.

- Configuring a VRF instance for IPv6
- Binding a VRF to an interface
- Creating a subinterface
- Configuring a static route for PE-to-CE-routing
- Configuring eBGP PE-to-CE routing sessions
- Configuring the IPv6 VPN address family for iBGP
- Configuring route reflectors for improved scalability
- Configuring Internet access

For detailed information about the configuration examples, see [Configuration Examples for IPv6 on Cable, on page 1056](#).



---

**Note** The IPv6 address of the sub-bundle interface (to which the CM is connected) is used in the DHCPv6 relay packet of the CPE DHCPv6 request. If the DHCPv6 packet has to go from one VRF interface to another, the IPv6 address of each VRF interface should be configured on the Cisco CMTS to establish connectivity.

---

## Configuring DHCPv6 Relay Agent

The Cisco CMTS router supports DHCPv6 relay agent to forward relay-forward messages from a specific source address to client relay destinations.

Perform the following steps to enable the DHCPv6 relay agent function and specify relay destination addresses on an interface.

### Before you begin

The relay-forward messages must contain specific source IPv6 address. This is required because the firewall deployed between the Cisco CMTS DHCPv6 relay agent and the DHCPv6 server expects only one source address for one Cisco CMTS bundle interface.



---

**Restriction** If you change one or more parameters of the **ipv6 dhcp relay destination** command, you have to disable the command using the **no** form, and execute the command again with changed parameters.

---

**Step 1** Run the following commands to specify an interface type and number, and to enter the interface configuration mode.

```
Router> enable
Router# configure terminal
Router(config)# interface type number
```



**Example:**

```
Router> enable
Router# configure terminal
Router(config)# interface ethernet 4/2
```

**Step 2** Specify the destination address to which the client packets are forwarded and enable the DHCPv6 relay service on the interface. **ipv6 dhcp relay destination** *ipv6-address* [*interface*] [**link-address** *link-address*] [**source-address** *source-address*]

```
ipv6 dhcp relay destination ipv6-address [interface] [link-address] [source-address]
```

**Example:**

```
Router(config-if)#ipv6 dhcp relay destination 2001:db8:1234::1 ethernet 4/2 link-address 2001:db8::1
source-address 2001:db8::2
```

## Configuring IPv6 Source Address and Link Address

In some network deployments, there is a firewall between CNR servers and CMTS router. The firewall only allows packets from certain addresses to transmit to CMTS router.

To allow the DHCPv6 message to be sent to CNR server with specific source address, user needs to configure the source address of the relayed forwarded DHCPv6 message in the following 3 ways:

1. In the global configuration mode, use the command **ipv6 dhcp-relay source-interface** *interface-type interface-number*
2. In the interface configuration mode, use the command **ipv6 dhcp relay source-interface** *interface-type interface-number*
3. In the interface configuration mode, use the command **ipv6 dhcp relay destination** *ipv6-address* [*interface*] [**link-address** *link-address*] [**source-address** *source-address*]

If the user does not have any of the above configuration, the DHCPv6 message will be relay forwarded with default source-address, which will be calculated based on relay destination address.

If any one of above is configured, the source-address of the DHCPv6 message will be based on that configuration.

If more than one configuration above is configured, the overriding rule is that more specific configuration wins, i.e., 3>2>1.

## Configurable DOCSIS CMTS Capabilities DHCPv6 Field

According to DOCSIS 3.1 specification, CMTS must support DOCSIS 3.0 cable modems and features. To support the backward compatibility of DOCSIS versions, the DHCPv6 vendor option must change from 30 to 31.

You can now upgrade to any DOCSIS version using the **cable docsis-ver** [**major version** | **minor version**] command.

The default value of the command is **cable docsis-ver 3 1**.

## Disabling IPv6 ND Gleaning

You must disable IPv6 ND gleaning before configuring IPv6 source verification using DHCPv6 leasequery.

### Procedure

|               | Command or Action                                                                                           | Purpose                                                                                                                                                                                                           |
|---------------|-------------------------------------------------------------------------------------------------------------|-------------------------------------------------------------------------------------------------------------------------------------------------------------------------------------------------------------------|
| <b>Step 1</b> | <b>enable</b><br><b>Example:</b><br><br>Router> enable                                                      | Enables privileged EXEC mode. Enter your password if prompted.                                                                                                                                                    |
| <b>Step 2</b> | <b>configure terminal</b><br><b>Example:</b><br><br>Router# configure terminal                              | Enters global configuration mode.                                                                                                                                                                                 |
| <b>Step 3</b> | <b>interfacebundle <i>bundle-no</i></b><br><b>Example:</b><br><br>Router(config)# <b>interface bundle 1</b> | Specifies a bundle interface number and enters bundle interface configuration mode. <ul style="list-style-type: none"> <li><i>bundle-no</i>—Bundle interface number. The valid range is from 1 to 255.</li> </ul> |
| <b>Step 4</b> | <b>no cable nd</b><br><b>Example:</b><br><br>Router(config-if) <b>no cable nd</b>                           | Disables IPv6 ND gleaning on the Cisco CMTS router.                                                                                                                                                               |
| <b>Step 5</b> | <b>end</b><br><b>Example:</b><br><br>Router(config-if) <b>end</b>                                           | Returns to privileged EXEC mode.                                                                                                                                                                                  |

## How to Verify IPv6 Dual Stack CPE Support

This section describes how to use **show** commands to verify the configuration of the IPv6 Dual Stack CPE Support on the CMTS feature.

### Procedure

|               | Command or Action                                             | Purpose                                                        |
|---------------|---------------------------------------------------------------|----------------------------------------------------------------|
| <b>Step 1</b> | <b>enable</b><br><b>Example:</b><br><br>Router> <b>enable</b> | Enables privileged EXEC mode. Enter your password if prompted. |

|        | Command or Action                                                                                                                                                                                                                                                                                           | Purpose                                                                                                                         |
|--------|-------------------------------------------------------------------------------------------------------------------------------------------------------------------------------------------------------------------------------------------------------------------------------------------------------------|---------------------------------------------------------------------------------------------------------------------------------|
| Step 2 | <b>show cable modem</b> [ <i>ip-address</i>   <i>mac-address</i> ] <b>ipv6</b> [ <b>cpe</b>   <b>prefix</b>   <b>registered</b>   <b>unregistered</b> ]<br><b>Example:</b><br>Router# <b>show cable modem ipv6 registered</b><br><b>Example:</b><br>Router# <b>show cable modem 0019.474a.c14a ipv6 cpe</b> | Displays IPv6 information for specified CMs and CPEs behind a CM on a Cisco CMTS router. You can specify the following options: |
| Step 3 | <b>show cable modem</b> [ <i>ip-address</i>   <i>mac-address</i> ] <b>registered</b><br><b>Example:</b><br>Router# <b>show cable modem 0019.474e.e4DF registered</b>                                                                                                                                        | Displays a list of the CMs that have registered with the Cisco CMTS. You can specify the following options:                     |
| Step 4 | <b>show cable modem</b> { <i>ip-address</i>   <i>mac-address</i> } <b>cpe</b><br><b>Example:</b><br>Router# <b>show cable modem 0019.474a.c14a cpe</b>                                                                                                                                                      | Displays the CPE devices accessing the cable interface through a particular CM. You can specify the following options:          |

## Examples

Use the **show cable modem ipv6** command to display the IPv6 portion of a dual stack CPE and use the **show cable modem cpe** command to display the IPv4 mode of a dual stack CPE. Both **show cable modem ipv6 registered** and **show cable modem registered** commands display CPE count as one for a dual stack CPE.

The following example shows the output of the **show cable modem ipv6** command:

```
Router# show cable modem ipv6 registered
Interface   Prim Online   CPE IP Address   MAC Address
           Sid  State
C4/0/U2    1    online        0    ---          0019.474a.c18c
C4/0/U2    3    online(pt)     1    2001:420:3800:809:EDA4:350C:2F75:4779 0019.474a.c14a
Router# show cable modem 0019.474a.c14a ipv6 cpe
MAC Address   IP Address   Domain Name
0005.0052.2c1d 2001:420:3800:809:48F7:3C33:B774:9185
```

The following example shows the output of the **show cable modem ipv6** command:

```
Router# show cable modem
0023.bed9.4c8e ipv6 cpe
Load for five secs: 0%/0%; one minute: 1%; five minutes: 1%
Time source is hardware calendar, *06:37:20.439 UTC Thu Aug 2 2012
MAC Address   IP Address
0023.bed9.4c91 2001:40:3:4:200:5EB7:BB6:C759
2001:40:3:4:210:D73B:7A50:2D05
```

The following example shows the output of the **show cable modem registered** command:

```
Router# show cable modem registered
Interface   Prim Online   Timing Rec   QoS CPE IP address   MAC address
           Sid  State      Offset Power
C4/0/U2    3    online     1022   0.00   2   1   50.3.37.12   0019.474a.c14a
```

The following example shows the output of the **show cable modem cpe** command:

```
Router# show cable modem 0019.474a.c14a cpe
IP address          MAC address      Dual IP
50.3.37.3          0005.0052.2c1d  Y
```

## Configuration Examples for IPv6 on Cable

This section includes the following examples:

### Example: IPv6 over Subinterfaces

The following example shows the CMTS bundle configuration that can be used with subinterfaces:

```
Router# show cable modem ipv6
Device Type: B - CM Bridge, R - CM Router
IP Assignment Method: D - DHCP
MAC Address      Type Interface      Mac State      D/IP IP Address
0019.474a.c18c  B/D  C4/0/U2          online         Y  2001:420:3800:809:4C7A:D518:91
C6:8A18
Router# show run interface bundle2
Building configuration...
Current configuration : 138 bytes
!
interface Bundle2
 no ip address
 cable arp filter request-send 3 2
 cable arp filter reply-accept 3 2
 no cable ip-multicast-echo
end
Router#

show run interface bundle2.1
Building configuration...
Current configuration : 382 bytes
!
interface Bundle2.1
 ip address 50.3.37.1 255.255.255.0
 no cable ip-multicast-echo
 cable helper-address 10.10.0.12
 ipv6 address 2001:DB8::/32
 ipv6 enable
 ipv6 nd prefix default no-advertise
 ipv6 nd managed-config-flag
 ipv6 nd other-config-flag
 ipv6 nd ra interval msec 2000
 ipv6 dhcp relay destination 2001:420:3800:800:203:BAFF:FE11:B644
 arp timeout 240
end
```

### Example: Basic IPv6 Cable Filter Groups

The following example shows the configuration of an IPv6 filter group that drops traffic from a specific IPv6 host (with source address 2001:DB8::1/48) behind a cable router to an IPv6 host on the network (with destination address 2001:DB8::5/64):

```

configure terminal
!
! Specify the filter group criteria using a common group ID
!
cable filter group 254 index 128 v6-src-address 2001:DB8::1
cable filter group 254 index 128 v6-src-pfxlen 128
cable filter group 254 index 128 v6-dest-address 2001:DB8::5
cable filter group 254 index 128 v6-dest-pfxlen 128
!
! Specify that the filter group is IP version 6
!
cable filter group 254 index 128 ip-version ipv6
!
! Specify the drop action for matching packets
!
cable filter group 254 index 128 match-action drop
!
! Apply the filter group with ID 254 to all CM upstream traffic
!
cable submgmt default filter-group cm upstream 254

```

## Example: Complete Cable Configuration with IPv6

The following example shows a complete cable configuration example; it also displays the configuration of multiple cable filter groups using both IPv4 and IPv6 and separate indexes to associate the filter definitions with the same group ID.

```

Router# show running-config
Building configuration...
Current configuration : 15010 bytes
!
! Last configuration change at 08:32:14 PST Thu Nov 8 2007
!
version 12.2
no service pad
service timestamps debug uptime
service timestamps log uptime
no service password-encryption
service internal
service compress-config
!
hostname router
!
boot-start-marker
boot-end-marker
!
enable password password1
!
no aaa new-model
clock timezone PST -9
clock summer-time PDT recurring
clock calendar-valid
facility-alarm core-temperature major 53
facility-alarm core-temperature minor 45
facility-alarm core-temperature critical 85
facility-alarm intake-temperature major 49
facility-alarm intake-temperature minor 40
facility-alarm intake-temperature critical 67
!
!

```

## Example: Complete Cable Configuration with IPv6

```

card 1/0 2jacket-1
card 1/0/0 24rfchannel-spa-1
card 5/0 5cable-mc520h-d
cable admission-control preempt priority-voice
cable modem vendor 00.18.68 SA-DPC2203
cable modem vendor 00.19.47 SA-DPC2505
no cable qos permission create
no cable qos permission update
cable qos permission modems
!
cable filter group 1 index 1 src-ip 0.0.0.0
cable filter group 1 index 1 src-mask 0.0.0.0
cable filter group 1 index 1 dest-ip 0.0.0.0
cable filter group 1 index 1 dest-mask 0.0.0.0
cable filter group 2 index 1 src-ip 0.0.0.0
cable filter group 2 index 1 src-mask 0.0.0.0
cable filter group 2 index 1 dest-ip 0.0.0.0
cable filter group 2 index 1 dest-mask 0.0.0.0
cable filter group 3 index 1 src-ip 0.0.0.0
cable filter group 3 index 1 src-mask 0.0.0.0
cable filter group 3 index 1 dest-ip 0.0.0.0
cable filter group 3 index 1 dest-mask 0.0.0.0
cable filter group 4 index 1 src-ip 0.0.0.0
cable filter group 4 index 1 src-mask 0.0.0.0
cable filter group 4 index 1 dest-ip 0.0.0.0
cable filter group 4 index 1 dest-mask 0.0.0.0
cable filter group 5 index 1 src-ip 0.0.0.0
cable filter group 5 index 1 src-mask 0.0.0.0
cable filter group 5 index 1 dest-ip 0.0.0.0
cable filter group 5 index 1 dest-mask 0.0.0.0
cable filter group 6 index 1 src-ip 0.0.0.0
cable filter group 6 index 1 src-mask 0.0.0.0
cable filter group 6 index 1 dest-ip 0.0.0.0
cable filter group 6 index 1 dest-mask 0.0.0.0
cable filter group 7 index 1 src-ip 0.0.0.0
cable filter group 7 index 1 src-mask 0.0.0.0
cable filter group 7 index 1 dest-ip 0.0.0.0
cable filter group 7 index 1 dest-mask 0.0.0.0
cable filter group 8 index 1 src-ip 0.0.0.0
cable filter group 8 index 1 src-mask 0.0.0.0
cable filter group 8 index 1 dest-ip 0.0.0.0
cable filter group 8 index 1 dest-mask 0.0.0.0
cable filter group 9 index 1 src-ip 0.0.0.0
cable filter group 9 index 1 src-mask 0.0.0.0
cable filter group 9 index 1 dest-ip 0.0.0.0
cable filter group 9 index 1 dest-mask 0.0.0.0
cable filter group 10 index 1 src-ip 0.0.0.0
cable filter group 10 index 1 src-mask 0.0.0.0
cable filter group 10 index 1 dest-ip 0.0.0.0
cable filter group 10 index 1 dest-mask 0.0.0.0
cable filter group 12 index 1 src-ip 0.0.0.0
cable filter group 12 index 1 src-mask 0.0.0.0
cable filter group 12 index 1 dest-ip 0.0.0.0
cable filter group 12 index 1 dest-mask 0.0.0.0
cable filter group 16 index 1 src-ip 0.0.0.0
cable filter group 16 index 1 src-mask 0.0.0.0
cable filter group 16 index 1 dest-ip 0.0.0.0
cable filter group 16 index 1 dest-mask 0.0.0.0
ip subnet-zero
ip domain name cisco.com
ip host host1 239.192.254.254
ip host host2 239.192.254.253
ip name-server 10.39.26.7
ip name-server 2001:0DB8:4321:FFFF:0:800:20CA:D8BA

```

```

!
!
!
!
ipv6 unicast-routing
ipv6 cef
packetcable multimedia
packetcable
!
!
!
redundancy
mode sso
!
!
controller Modular-Cable 1/0/0
annex B modulation 64qam 0 23
ip-address 10.30.4.175
modular-host subslot 5/0
rf-channel 0 cable downstream channel-id 24
rf-channel 1 cable downstream channel-id 25
rf-channel 2 cable downstream channel-id 26
rf-channel 3 cable downstream channel-id 27
rf-channel 4 cable downstream channel-id 28
rf-channel 5 cable downstream channel-id 29
rf-channel 6 cable downstream channel-id 30
rf-channel 7 cable downstream channel-id 31
rf-channel 8 cable downstream channel-id 32
rf-channel 9 cable downstream channel-id 33
rf-channel 10 cable downstream channel-id 34
rf-channel 11 cable downstream channel-id 35
rf-channel 12 cable downstream channel-id 36
rf-channel 13 cable downstream channel-id 37
rf-channel 14 cable downstream channel-id 38
rf-channel 15 cable downstream channel-id 39
rf-channel 16 cable downstream channel-id 40
rf-channel 17 cable downstream channel-id 41
rf-channel 18 cable downstream channel-id 42
rf-channel 19 cable downstream channel-id 43
rf-channel 20 cable downstream channel-id 44
rf-channel 21 cable downstream channel-id 45
rf-channel 22 cable downstream channel-id 46
rf-channel 23 cable downstream channel-id 47
!
!
policy-map foo
policy-map 1
policy-map cos
policy-map qpolicy
policy-map shape
policy-map dscp
!
!
!
!
!
interface Loopback0
ip address 127.0.0.1 255.255.255.255
!
interface FastEthernet0/0/0
ip address 10.39.21.10 255.255.0.0
speed 100
half-duplex

```

## Example: Complete Cable Configuration with IPv6

```

    ipv6 address 2001:DB8::/32
    ipv6 enable
    !
interface Wideband-Cable1/0/0:0
  no cable packet-cache
  cable bonding-group-id 1
  !
interface Wideband-Cable1/0/0:1
  no cable packet-cache
  cable bonding-group-id 2
  !
interface Wideband-Cable1/0/0:2
  no cable packet-cache
  cable bonding-group-id 3
  !
interface Wideband-Cable1/0/0:3
  no cable packet-cache
  cable bonding-group-id 4
  !
interface Wideband-Cable1/0/0:4
  no cable packet-cache
  cable bundle 1
  cable bonding-group-id 5
  cable rf-channel 1 bandwidth-percent 60
  !
interface Wideband-Cable1/0/0:5
  no cable packet-cache
  cable bundle 1
  cable bonding-group-id 6
  cable rf-channel 0 bandwidth-percent 40
  cable rf-channel 2
  cable rf-channel 3
  !
interface Wideband-Cable1/0/0:6
  no cable packet-cache
  cable bonding-group-id 7
  !
interface Wideband-Cable1/0/0:7
  no cable packet-cache
  cable bonding-group-id 8
  !
interface Wideband-Cable1/0/0:8
  no cable packet-cache
  cable bonding-group-id 9
  !
interface Wideband-Cable1/0/0:9
  no cable packet-cache
  cable bonding-group-id 33
  !
interface Wideband-Cable1/0/0:10
  no cable packet-cache
  cable bonding-group-id 34
  !
interface Wideband-Cable1/0/0:11
  no cable packet-cache
  cable bonding-group-id 35
  !
interface Cable5/0/0
  no cable packet-cache
  cable bundle 1
  cable downstream channel-id 119
  cable downstream annex B
  cable downstream modulation 256qam
  cable downstream interleave-depth 32

```



```
cable downstream frequency 99000000
no cable downstream rf-shutdown
cable upstream max-ports 4
cable upstream 0 connector 0
cable upstream 0 frequency 6000000
cable upstream 0 ingress-noise-cancellation 200
cable upstream 0 docsis-mode tdma
cable upstream 0 channel-width 1600000 1600000
cable upstream 0 minislots-size 4
cable upstream 0 range-backoff 3 6
cable upstream 0 modulation-profile 21
no cable upstream 0 shutdown
cable upstream 1 connector 1
cable upstream 1 ingress-noise-cancellation 200
cable upstream 1 docsis-mode tdma
cable upstream 1 channel-width 1600000 1600000
cable upstream 1 minislots-size 4
cable upstream 1 range-backoff 3 6
cable upstream 1 modulation-profile 21
cable upstream 1 shutdown
cable upstream 2 connector 2
cable upstream 2 ingress-noise-cancellation 200
cable upstream 2 docsis-mode tdma
cable upstream 2 channel-width 1600000 1600000
cable upstream 2 minislots-size 4
cable upstream 2 range-backoff 3 6
cable upstream 2 modulation-profile 21
cable upstream 2 shutdown
cable upstream 3 connector 3
cable upstream 3 ingress-noise-cancellation 200
cable upstream 3 docsis-mode tdma
cable upstream 3 channel-width 1600000 1600000
cable upstream 3 minislots-size 4
cable upstream 3 range-backoff 3 6
cable upstream 3 modulation-profile 21
cable upstream 3 shutdown
!
interface Cable5/0/1
cable ip-init ipv6
no cable packet-cache
cable bundle 1
cable downstream channel-id 120
cable downstream annex B
cable downstream modulation 64qam
cable downstream interleave-depth 32
cable downstream frequency 705000000
no cable downstream rf-shutdown
cable upstream max-ports 4
cable upstream 0 connector 4
cable upstream 0 frequency 6000000
cable upstream 0 ingress-noise-cancellation 200
cable upstream 0 docsis-mode tdma
cable upstream 0 channel-width 1600000 1600000
cable upstream 0 minislots-size 4
cable upstream 0 range-backoff 3 6
cable upstream 0 modulation-profile 21
no cable upstream 0 shutdown
cable upstream 1 connector 5
cable upstream 1 ingress-noise-cancellation 200
cable upstream 1 docsis-mode tdma
cable upstream 1 channel-width 1600000 1600000
cable upstream 1 minislots-size 4
cable upstream 1 range-backoff 3 6
cable upstream 1 modulation-profile 21
```

## Example: Complete Cable Configuration with IPv6

```

cable upstream 1 shutdown
cable upstream 2 connector 6
cable upstream 2 ingress-noise-cancellation 200
cable upstream 2 docsis-mode tdma
cable upstream 2 channel-width 1600000 1600000
cable upstream 2 minislots-size 4
cable upstream 2 range-backoff 3 6
cable upstream 2 modulation-profile 21
cable upstream 2 shutdown
cable upstream 3 connector 7
cable upstream 3 ingress-noise-cancellation 200
cable upstream 3 docsis-mode tdma
cable upstream 3 channel-width 1600000 1600000
cable upstream 3 minislots-size 4
cable upstream 3 range-backoff 3 6
cable upstream 3 modulation-profile 21
cable upstream 3 shutdown
!
interface Cable5/0/2
no cable packet-cache
cable downstream channel-id 121
cable downstream annex B
cable downstream modulation 64qam
cable downstream interleave-depth 32
cable downstream rf-shutdown
cable upstream max-ports 4
cable upstream 0 connector 8
cable upstream 0 ingress-noise-cancellation 200
cable upstream 0 docsis-mode tdma
cable upstream 0 channel-width 1600000 1600000
cable upstream 0 minislots-size 4
cable upstream 0 range-backoff 3 6
cable upstream 0 modulation-profile 21
cable upstream 0 shutdown
cable upstream 1 connector 9
cable upstream 1 ingress-noise-cancellation 200
cable upstream 1 docsis-mode tdma
cable upstream 1 channel-width 1600000 1600000
cable upstream 1 minislots-size 4
cable upstream 1 range-backoff 3 6
cable upstream 1 modulation-profile 21
cable upstream 1 shutdown
cable upstream 2 connector 10
cable upstream 2 ingress-noise-cancellation 200
cable upstream 2 docsis-mode tdma
cable upstream 2 channel-width 1600000 1600000
cable upstream 2 minislots-size 4
cable upstream 2 range-backoff 3 6
cable upstream 2 modulation-profile 21
cable upstream 2 shutdown
cable upstream 3 connector 11
cable upstream 3 ingress-noise-cancellation 200
cable upstream 3 docsis-mode tdma
cable upstream 3 channel-width 1600000 1600000
cable upstream 3 minislots-size 4
cable upstream 3 range-backoff 3 6
cable upstream 3 modulation-profile 21
cable upstream 3 shutdown
!
interface Cable5/0/3
no cable packet-cache
cable downstream channel-id 122
cable downstream annex B
cable downstream modulation 64qam

```

```
cable downstream interleave-depth 32
cable downstream rf-shutdown
cable upstream max-ports 4
cable upstream 0 connector 12
cable upstream 0 ingress-noise-cancellation 200
cable upstream 0 docsis-mode tdma
cable upstream 0 channel-width 1600000 1600000
cable upstream 0 minislots-size 4
cable upstream 0 range-backoff 3 6
cable upstream 0 modulation-profile 21
cable upstream 0 shutdown
cable upstream 1 connector 13
cable upstream 1 ingress-noise-cancellation 200
cable upstream 1 docsis-mode tdma
cable upstream 1 channel-width 1600000 1600000
cable upstream 1 minislots-size 4
cable upstream 1 range-backoff 3 6
cable upstream 1 modulation-profile 21
cable upstream 1 shutdown
cable upstream 2 connector 14
cable upstream 2 ingress-noise-cancellation 200
cable upstream 2 docsis-mode tdma
cable upstream 2 channel-width 1600000 1600000
cable upstream 2 minislots-size 4
cable upstream 2 range-backoff 3 6
cable upstream 2 modulation-profile 21
cable upstream 2 shutdown
cable upstream 3 connector 15
cable upstream 3 ingress-noise-cancellation 200
cable upstream 3 docsis-mode tdma
cable upstream 3 channel-width 1600000 1600000
cable upstream 3 minislots-size 4
cable upstream 3 range-backoff 3 6
cable upstream 3 modulation-profile 21
cable upstream 3 shutdown
!
interface Cable5/0/4
no cable packet-cache
cable downstream channel-id 123
cable downstream annex B
cable downstream modulation 64qam
cable downstream interleave-depth 32
cable downstream rf-shutdown
cable upstream max-ports 4
cable upstream 0 connector 16
cable upstream 0 ingress-noise-cancellation 200
cable upstream 0 docsis-mode tdma
cable upstream 0 channel-width 1600000 1600000
cable upstream 0 minislots-size 4
cable upstream 0 range-backoff 3 6
cable upstream 0 modulation-profile 21
cable upstream 0 shutdown
cable upstream 1 connector 17
cable upstream 1 ingress-noise-cancellation 200
cable upstream 1 docsis-mode tdma
cable upstream 1 channel-width 1600000 1600000
cable upstream 1 minislots-size 4
cable upstream 1 range-backoff 3 6
cable upstream 1 modulation-profile 21
cable upstream 1 shutdown
cable upstream 2 connector 18
cable upstream 2 ingress-noise-cancellation 200
cable upstream 2 docsis-mode tdma
cable upstream 2 channel-width 1600000 1600000
```

```

cable upstream 2 minislots-size 4
cable upstream 2 range-backoff 3 6
cable upstream 2 modulation-profile 21
cable upstream 2 shutdown
cable upstream 3 connector 19
cable upstream 3 ingress-noise-cancellation 200
cable upstream 3 docsis-mode tdma
cable upstream 3 channel-width 1600000 1600000
cable upstream 3 minislots-size 4
cable upstream 3 range-backoff 3 6
cable upstream 3 modulation-profile 21
cable upstream 3 shutdown
!
interface Bundle1
ip address 10.46.2.1 255.255.0.0 secondary
ip address 10.46.1.1 255.255.0.0
cable arp filter request-send 3 2
cable arp filter reply-accept 3 2
cable dhcp-giaddr policy strict
cable helper-address 10.39.26.8
ipv6 address 2001:DB8::/32
ipv6 enable
ipv6 nd managed-config-flag
ipv6 nd other-config-flag
ipv6 nd ra interval 5
ipv6 dhcp relay destination 2001:0DB8:4321:FFFF:0:800:20CA:D8BA
!
ip default-gateway 10.39.0.1
ip classless
ip route 0.0.0.0 0.0.0.0 10.39.26.12
ip route 192.168.254.253 255.255.255.255 10.39.0.1
ip route 192.168.254.254 255.255.255.255 10.39.0.1
!
!
no ip http server
no ip http secure-server
!
logging cmts cr10k log-level errors
cpd cr-id 1
nls resp-timeout 1
cdp run
!
tftp-server bootflash:docs10.cm alias docs10.cm
tftp-server bootflash:rfs_w_x373.bin alias rfs_w_x373.bin
snmp-server community private RW
snmp-server enable traps cable
snmp-server manager
!
!
control-plane
!
!
line con 0
logging synchronous
stopbits 1
line aux 0
line vty 0 4
password lab
login
!
!
cable fiber-node 1
downstream Modular-Cable 1/0/0 rf-channel 1
upstream Cable 5/0 connector 0

```

```

!
cable fiber-node 2
  downstream Modular-Cable 1/0/0 rf-channel 0 2-3
  upstream Cable 5/0 connector 4
!
end

```

## Example: BGP Configuration for 6VPE

The following example shows a sample BGP configuration on CMTS 6VPE.

```

Router# router bgp 1
no synchronization
bgp log-neighbor-changes
neighbor 11.1.1.5 remote-as 1
neighbor 11.1.1.5 update-source Loopback1
no auto-summary
!
address-family vpnv6          --- Enable vpnv6 AF
  neighbor 11.1.1.5 activate   --- Activate neighbor 6VPE-2
  neighbor 11.1.1.5 send-community extended
exit-address-family
!
address-family ipv6 vrf vrf_mgmt  ---- Publish directly connected route
  redistribute connected
  redistribute static
  no synchronization
exit-address-family
!
address-family ipv6 vrf vrfa  --- Enable IPv6 vrf AF for each VRF
  redistribute connected
  no synchronization
exit-address-family
!
address-family ipv6 vrf vrfb  --- Enable IPv6 vrf AF for each VRF
  redistribute connected
  no synchronization
exit-address-family
!

```

## Example: Subinterface Configuration for 6VPE

The following example shows how to define a subinterface on virtual bundle interface 1.

When configuring IPv6 VPNs, you must configure the first subinterface created as a part of the management VRF. In the following example, Bundle 1.10 is the first sub-interface, which is configured into management VRF. Make sure the CNR server is reachable in management VRF.

```

interface Bundle1.10          --- Management VRF
vrf forwarding vrf_mgmt
cable dhcp-giaddr primary
ipv6 address 2001:40:3:110::1/64
ipv6 enable
ipv6 nd managed-config-flag
ipv6 nd other-config-flag
ipv6 dhcp relay destination 2001:10:74:129::2
interface Bundle1.11        --- VRF A
vrf forwarding vrfa
cable dhcp-giaddr primary

```

```

ipv6 address 2001:40:3:111::1/64
ipv6 enable
ipv6 dhcp relay destination 2001:10:74:129::2
interface Bundle1.12      --- VRFB
vrf forwarding vrfb
cable dhcp-giaddr primary
ipv6 address 2001:40:3:112::1/64
ipv6 enable
ipv6 dhcp relay destination 2001:10:74:129::2

```

## Example: Cable Interface Bundling

The following example shows how to bundle a group of physical interfaces.

```

int C5/0/4 and int c5/0/3 are bundled.
int c5/0/4
cable bundle 1
int c5/0/3
cable bundle 1

```

## Example: VRF Configuration for 6VPE

The following example shows how to create VRFs for each VPN.

```

vrf definition vrf_mgmt
rd 1:1
!
address-family ipv4
route-target export 1:1
route-target import 1:1
route-target import 2:2
route-target import 2:1
exit-address-family
!
address-family ipv6
route-target export 1:1
route-target import 1:1
route-target import 2:1 -- import route of vrfa
route-target import 2:2 -- import route of vrfb
exit-address-family

```

## Verifying IPv6 on Cable

This section explains how to verify IPv6 on cable configuration and it contains the following topics:

### Verifying IPv6 VRF Configuration

To verify the IPv6 VRF configuration, use the `show vrf ipv6` command in privileged EXEC mode.

```

Router# show vrf ipv6 vrfa
  Name                Default RD      Protocols  Interfaces
  vrfa                2:1            ipv4,ipv6  Bul.11
Router# show vrf ipv6 interfaces
Interface            VRF            Protocol  Address

```

```

Bul.10          vrf_mgmt          up          2001:40:3:110::1
Fa0/0/0         vrf_mgmt          up          2001:20:4:1::38
Bul.11          vrfa              up          2001:40:3:111::1
Bul.12          vrfb              up          2001:40:3:112::1
CMTS#

```

## Verifying IPv6 BGP Status

To verify the IPv6 BGP status, use the `show ip bgp` command in privileged EXEC mode.

```

Router# show ip bgp vpnv6 unicast all neighbors

BGP neighbor is 11.1.1.5, remote AS 1, internal link
  BGP version 4, remote router ID 11.1.1.5
  Session state = Established, up for 00:35:52
  Last read 00:00:37, last write 00:00:14, hold time is 180, keepalive interval is 60 seconds

BGP multisession with 2 sessions (2 established), first up for 00:40:07
Neighbor sessions:
  2 active, is multisession capable
Neighbor capabilities:
  Route refresh: advertised and received(new) on session 1, 2
  Address family IPv4 Unicast: advertised and received
  Address family VPNv6 Unicast: advertised and received
.....

```

## Verifying MPLS Forwarding Table

To verify the output of the MPLS forwarding table, use the `show mpls forwarding-table` command in the privileged EXEC mode.

```

Router# show mpls forwarding-table

Local  Outgoing  Prefix          Bytes Label  Outgoing  Next Hop
Label  Label or VC or Tunnel Id  Switched    interface
.....
19     No Label   2001:40:3:110::/64[V]  \          ---Route in
vrf_mgmt                                     0          aggregate/vrf_mgmt
21     No Label   2001:40:3:111::/64[V]  \          ---Route in
vrfa   0          aggregate/vrfa
22     No Label   2001:40:3:112::/64[V]  \          ---Route in
vrfb   0          aggregate/vrfb
.....

```

## Verifying IPv6 Cable Modem and its Host State

To verify IPv6 addresses and connected host states of cable modems and CPEs, use the `show interface cable modem` command in the privileged EXEC mode:

```
Router# show interface cable 7/0/0 modem ipv6
SID Type State IPv6 Address M MAC address
11 CM online 2001:420:3800:809:3519:5F9C:B96A:D31 D 0025.2e2d.743a
11 CPE unknown 2001:420:3800:809:3DB2:8A6C:115F:41D8 D 0011.2544.f33b
```

## Verifying Multiple IAPDs in a Single Advertise

To verify the multiple IPv6 prefixes assigned to devices on a network, use the `show cable modem ipv6 prefix` command in privileged EXEC mode:

```
Router# show cable modem ipv6 prefix
Load for five secs: 1%/0%; one minute: 1%; five minutes: 1%
Time source is hardware calendar, *06:36:53.075 UTC Thu Aug 2 2012
Device Type: B - CM Bridge, R - CM Router
IP Assignment Method: D - DHCP
MAC Address Type IPv6 prefix
0023.bed9.4c91 R/D 2001:40:1012::/64
R/D 2001:40:2012:1::/64
0000.002e.074c R/D 2001:40:1012:8::/64
R/D 2001:40:2012:1D::/64
0000.002e.074b R/D 2001:40:1012:23::/64
R/D 2001:40:2012:1C::/64
0000.002e.074a R/D 2001:40:1012:22::/64
R/D 2001:40:2012:1B::/64
```

To verify the multiple IPv6 prefixes assigned to CPEs behind a CM with a specific MAC address, use the `show cable modem mac-address ipv6 prefix` command in privileged EXEC mode:

```
Router# show cable modem 0023.bed9.4c8e ipv6 prefix
Load for five secs: 0%/0%; one minute: 1%; five minutes: 1%
Time source is hardware calendar, *06:37:22.335 UTC Thu Aug 2 2012
Device Type: B - CM Bridge, R - CM Router
IP Assignment Method: D - DHCP
MAC Address Type IPv6 prefix
0023.bed9.4c91 R/D 2001:40:1012::/64
R/D 2001:40:2012:1::/64
```

To verify the IPv6 information of CPEs behind a CM with a specific MAC address, use the `show cable modem mac-address ipv6 cpe` command in privileged EXEC mode:

```
Router# show cable modem 0023.bed9.4c8e ipv6 cpe
Load for five secs: 0%/0%; one minute: 1%; five minutes: 1%
Time source is hardware calendar, *06:37:20.439 UTC Thu Aug 2 2012
MAC Address IP Address
0023.bed9.4c91 2001:40:3:4:200:5EB7:BB6:C759
2001:40:3:4:210:D73B:7A50:2D05
```

## Supported MIBs

### CISCO-DOCS-EXT-MIB

The CISCO-DOCS-EXT-MIB contains objects that support extensions to the Data-over-Cable Service Interface Specifications (DOCSIS) interface MIB, DOCS-IF-MIB.

- `CdxBundleIpHelperEntry`—Provides a list of cable helper entries on the bundle and sub-bundle interfaces.



- `CdxBundleIPv6DHCPRelayEntry`—Contains the IPv6 DHCP relay option, IPv6 DHCP relay source-interface details, and IPv6 DHCP relay trust configuration on a bundle and sub-bundle interface.
- `CdxBundleIPv6DHCPRelayDestEntry`—Contains a list of IPv6 DHCP relay destination entries on the cable bundle and sub-bundle interfaces.

## Additional References

### Technical Assistance

| Description                                                                                                                                                                                                                                                                                                                                                                                                                                                                                                                                                             | Link                                                                    |
|-------------------------------------------------------------------------------------------------------------------------------------------------------------------------------------------------------------------------------------------------------------------------------------------------------------------------------------------------------------------------------------------------------------------------------------------------------------------------------------------------------------------------------------------------------------------------|-------------------------------------------------------------------------|
| <p>The Cisco Support website provides extensive online resources, including documentation and tools for troubleshooting and resolving technical issues with Cisco products and technologies.</p> <p>To receive security and technical information about your products, you can subscribe to various services, such as the Product Alert Tool (accessed from Field Notices), the Cisco Technical Services Newsletter, and Really Simple Syndication (RSS) Feeds.</p> <p>Access to most tools on the Cisco Support website requires a Cisco.com user ID and password.</p> | <a href="http://www.cisco.com/support">http://www.cisco.com/support</a> |

## Feature Information for IPv6 on Cable

Use Cisco Feature Navigator to find information about the platform support and software image support. Cisco Feature Navigator enables you to determine which software images support a specific software release, feature set, or platform. To access Cisco Feature Navigator, go to the <https://cfng.cisco.com/> link. An account on the Cisco.com page is not required.



**Note** The following table lists the software release in which a given feature is introduced. Unless noted otherwise, subsequent releases of that software release train also support that feature.

*Table 223: Feature Information for Downstream Interface Configuration*

| Feature Name                                       | Releases                        | Feature Information                                                              |
|----------------------------------------------------|---------------------------------|----------------------------------------------------------------------------------|
| Enabling MDD with Pre-Registration DSID            | Cisco IOS XE Gibraltar 16.12.1x | This feature was introduced on the Cisco cBR Series Converged Broadband Routers. |
| Configurable DOCSIS CMTS Capabilities DHCPv6 Field | Cisco IOS XE Fuji 16.7.1        | This feature was introduced on the Cisco cBR Series Converged Broadband Routers. |

| Feature Name  | Releases                    | Feature Information                                                                |
|---------------|-----------------------------|------------------------------------------------------------------------------------|
| IPv6 on cable | Cisco IOS XE Everest 16.6.1 | This feature was integrated into the Cisco cBR Series Converged Broadband Routers. |



## CHAPTER 63

# Cable DHCP Leasequery

This document describes the Dynamic Host Configuration Protocol (DHCP) Leasequery feature on the Cisco cable modem termination system (CMTS) router.

Your software release may not support all the features that are documented in this module. For the latest feature information and caveats, see the release notes for your platform and software release. The Feature Information Table at the end of this document provides information about the documented features and lists the releases in which each feature is supported.

Use Cisco Feature Navigator to find information about platform support and Cisco software image support. To access Cisco Feature Navigator, go to <http://tools.cisco.com/ITDIT/CFN/>. An account on <http://www.cisco.com/> is not required.

### Contents

- [Hardware Compatibility Matrix for the Cisco cBR Series Routers, on page 1071](#)
- [Prerequisites for Cable DHCP Leasequery, on page 1073](#)
- [Restrictions for Cable DHCP Leasequery, on page 1073](#)
- [Information About Cable DHCP Leasequery, on page 1073](#)
- [How to Configure Filtering of Cable DHCP Leasequery Requests, on page 1075](#)
- [Configuration Examples for Filtering of DHCP Leasequery , on page 1079](#)
- [Additional References, on page 1080](#)
- [Feature Information for Cable DHCP Leasequery, on page 1080](#)

## Hardware Compatibility Matrix for the Cisco cBR Series Routers



---

**Note** The hardware components that are introduced in a given Cisco IOS-XE Release are supported in all subsequent releases unless otherwise specified.

---

Table 224: Hardware Compatibility Matrix for the Cisco cBR Series Routers

| Cisco CMTS Platform                    | Processor Engine                                                                                                                                                                                  | Interface Cards                                                                                                                                                                                                                                                                                                                                                                                                                                                                                                                                                                                                                                                                                                                                                                                 |
|----------------------------------------|---------------------------------------------------------------------------------------------------------------------------------------------------------------------------------------------------|-------------------------------------------------------------------------------------------------------------------------------------------------------------------------------------------------------------------------------------------------------------------------------------------------------------------------------------------------------------------------------------------------------------------------------------------------------------------------------------------------------------------------------------------------------------------------------------------------------------------------------------------------------------------------------------------------------------------------------------------------------------------------------------------------|
| Cisco cBR-8 Converged Broadband Router | <p><b>Cisco IOS-XE Release 16.5.1 and Later Releases</b></p> <p>Cisco cBR-8 Supervisor:</p> <ul style="list-style-type: none"> <li>• PID—CBR-SUP-250G</li> <li>• PID—CBR-CCAP-SUP-160G</li> </ul> | <p><b>Cisco IOS-XE Release 16.5.1 and Later Releases</b></p> <p>Cisco cBR-8 CCAP Line Cards:</p> <ul style="list-style-type: none"> <li>• PID—CBR-LC-8D30-16U30</li> <li>• PID—CBR-LC-8D31-16U30</li> <li>• PID—CBR-RF-PIC</li> <li>• PID—CBR-RF-PROT-PIC</li> <li>• PID—CBR-CCAP-LC-40G</li> <li>• PID—CBR-CCAP-LC-40G-R</li> <li>• PID—CBR-CCAP-LC-G2-R</li> <li>• PID—CBR-SUP-8X10G-PIC</li> <li>• PID—CBR-2X100G-PIC</li> </ul> <p>Digital PICs:</p> <ul style="list-style-type: none"> <li>• PID—CBR-DPIC-8X10G</li> <li>• PID—CBR-DPIC-2X100G</li> </ul> <p>Cisco cBR-8 Downstream PHY Module:</p> <ul style="list-style-type: none"> <li>• PID—CBR-D31-DS-MOD</li> </ul> <p>Cisco cBR-8 Upstream PHY Modules:</p> <ul style="list-style-type: none"> <li>• PID—CBR-D31-US-MOD</li> </ul> |



**Note** Do not use DPICs (8X10G and 2x100G) to forward IP traffic, as it may cause buffer exhaustion, leading to line card reload.

The only allowed traffic on a DPIC interface is DEPI, UEPI, and GCP traffic from the Cisco cBR-8 router to Remote PHY devices. Other traffic such as DHCP, SSH, and UTSC should flow via another router, since DPICs cannot be used for normal routing.

## Prerequisites for Cable DHCP Leasequery

- You must configure a cable interface with the **cable source-verify dhcp** command and the **no cable arp** command before the Cisco CMTS router can enable DHCP Leasequery. Lease queries are sent to the DHCP server or to a configured alternate server.

To divert DHCP Leasequeries to a specific server, you must use the cable **source-verify dhcp server** ipaddress command and the **no cable arp** command before the Cisco CMTS router is enabled for DHCP Leasequery. Only one alternate server may be configured.

- You must configure the **ipv6 route** command when IPv6 Customer Premise Equipment (CPE) routers are deployed on the Cisco CMTS router.

## Restrictions for Cable DHCP Leasequery

- Leasequeries are sent to the DHCP server unless an alternate server is configured.
- Only one alternate server can be configured.
- Users are responsible for the synchronization of the DHCP server and the configured alternate server.
- If the configured alternate server fails, leasequery requests are *not* returned to the DHCP server.
- Only one IA\_IADDR is supported per client. If the leasequery returns multiple results, only the IA\_ADDR matching the query is added to the Cisco CMTS subscriber database.
- The Cisco CMTS will not verify the source of the IPv6 link-local address of a CPE.

## Information About Cable DHCP Leasequery

Problems can occur when viruses, denial of service (DoS) attacks, and theft-of-service attacks begin scanning a range of IP addresses, in an attempt to find unused addresses. When the Cisco CMTS router is verifying unknown IP addresses, this type of scanning generates a large volume of DHCP leasequeries, which can result in the following problems:

- High CPU utilization on the Cisco CMTS router PRE card.
- High utilization on the DHCP servers, resulting in a slow response time or no response at all.
- Packets can be dropped by the Cisco CMTS router or DHCP server (or configured alternate server).
- Lack of available bandwidth for other customers on the cable interface.

To prevent such a large volume of leasequery requests on cable interfaces, you can enable filtering of these requests on upstream interfaces, downstream interfaces, or both. When the Cable DHCP Leasequery feature is enabled, the Cisco CMTS allows only a certain number of DHCP leasequery requests for each service ID (SID) on an interface within the configured interval time period. If an SID generates more Leasequeries than the maximum, the router drops the excess number of requests until the next interval period begins.

You can configure both the number of allowable DHCP leasequery requests and the interval time period, so as to match the capabilities of your DHCP server (or configured alternate server) and cable network.

To configure the Cisco CMTS router to send DHCP leasequery requests to the DHCP server, use the **cable source-verify dhcp** and **no cable arp** commands. Unknown IP addresses that are found in packets for customer premises equipment (CPE) devices that use the cable modems on the cable interface are verified. The DHCP

server returns a DHCP ACK message with the DHCP relay information and lease information of the CPE device that has been assigned this IP address, if any.

When **cable source-verify dhcp** and **no cable arp** commands are configured, DHCP leasequery is sent for downstream packets to verify unknown IP addresses within the IP address range configured on the cable bundle interface.

For DHCP leasequery to work in the downstream direction, the Cisco Network Registrar (CNR) should be made aware of the DHCP Option 82. This is required to make the CMTS map the CPE IP address to the correct CM. To do this, configure the **ip dhcp relay information option** command on the bundle interface to insert service class relay agent option into the DHCP DISCOVER messages. When the configuration is in place, during DHCP DISCOVER the values of DHCP Option 82 is cached by the CNR and is returned to the CMTS on any subsequent DHCP leasequery for that IP address.

To configure the Cisco CMTS router to divert DHCP leasequery requests to a server other than the DHCP server, use the **cable source-verify dhcp server ipaddress** and **no cable arp** commands.

The Cisco CMTS supports two types of DHCP leasequery implementation, Cisco standard compliant DHCP leasequery and RFC 4388 standard compliant DHCP leasequery. These two standards differ mostly in the identifiers used to query or respond to the DHCP Server. You can choose between these two implementations depending on which standard is supported on your DHCP Server.

Use the **ip dhcp compatibility lease-query client {cisco | standard}** command to configure the Cisco CMTS in either Cisco mode or RFC 4388 standard mode.

## DHCP MAC Address Exclusion List

This feature enables the ability to exclude trusted MAC addresses from the standard DHCP source verification checks for the Cisco CMTS. The DHCP MAC Address Exclusion List feature enables packets from trusted MAC addresses to pass when otherwise packets would be rejected with standard DHCP source verification. This feature overrides the cable source-verify command on the Cisco CMTS for the specified MAC address, yet maintains overall support for standard and enabled DHCP source verification processes. This feature is supported on the Performance Routing Engine 1 (PRE1), PRE2, and PRE4 modules on the Cisco cBR router chassis.

To enable packets from trusted source MAC addresses in DHCP to pass without source verification checks, use the cable trust command in global configuration mode. To remove a trusted MAC address from the MAC exclusion list, use the no form of this command. Removing a MAC address from the exclusion list subjects all packets from that source to standard DHCP source verification.

For more information on the cable trust command, see the [Cisco IOS CMTS Cable Command Reference Guide](#).

## Unitary DHCPv6 Leasequery

This feature supports unitary DHCPv6 leasequery protocol (RFC 5007) on the Cisco CMTS routers for upstream IPv6 source verification. This protocol verifies the authenticity of the IPv6 CPE behind a home or small office cable deployment.

If the IPv6 source verification fails on the router and the **cable ipv6 source-verify dhcp** and **no cable nd** commands are configured on the bundle interface or subinterface, the Cisco CMTS triggers a unitary DHCPv6 leasequery to the Cisco Network Registrar (CNR). If a valid leasequery response is received from the CNR, the Cisco CMTS adds the CPE to its subscriber database and allows future traffic for the CPE.

The primary use of the unitary DHCPv6 leasequery protocol on the Cisco CMTS router is to recover lost CPE data including the Prefix Delegation (PD) route. The IPv6 CPE data can be lost from the Cisco CMTS in several ways. For example, PD route loss can occur during a Cisco CMTS reload.

The unitary DHCPv6 leasequery protocol also supports the following:

- DHCPv6 leasequery protocol.
- Rogue client database for failed source-verify clients.
- DHCPv6 leasequery filters.
- DHCPv6 leasequeries to a specific DHCPv6 server.

## How to Configure Filtering of Cable DHCP Leasequery Requests

Use the following procedures to configure the filtering of DHCP Leasequery requests on the Cisco CMTS downstreams and upstreams:

### Enabling DHCP Leasequery Filtering on Downstreams

Use the following procedure to start filtering DHCP leasequeries on all downstreams of a cable interface.

#### Procedure

|        | Command or Action                                                                                                                                                                                 | Purpose                                                                                                                                             |
|--------|---------------------------------------------------------------------------------------------------------------------------------------------------------------------------------------------------|-----------------------------------------------------------------------------------------------------------------------------------------------------|
| Step 1 | <b>enable</b><br><b>Example:</b><br>Router> <b>enable</b>                                                                                                                                         | Enables privileged EXEC mode. <ul style="list-style-type: none"> <li>• Enter your password if prompted.</li> </ul>                                  |
| Step 2 | <b>configure terminal</b><br><b>Example:</b><br>Router# <b>configure terminal</b>                                                                                                                 | Enters global configuration mode.                                                                                                                   |
| Step 3 | <b>cable source-verify leasequery-filter downstream</b><br><i>threshold interval</i><br><b>Example:</b><br>Router(config)# <b>cable source-verify</b><br><b>leasequery-filter downstream 5 10</b> | Enables leasequery filtering on all downstreams on the specified bundle interface, using the specified <i>threshold</i> and <i>interval</i> values. |
| Step 4 | <b>end</b><br><b>Example:</b><br>Router(config)# <b>end</b>                                                                                                                                       | Exits configuration mode and returns to privileged EXEC mode.                                                                                       |

## Enabling DHCP Leasequery Filtering on Upstreams

Use the following procedure to start filtering DHCP Leasequeries on all upstreams on a bundle interface.

### Procedure

|               | Command or Action                                                                                                                                                                  | Purpose                                                                                                                                                                                                                                                                                                                                                                                                                                                                                                        |
|---------------|------------------------------------------------------------------------------------------------------------------------------------------------------------------------------------|----------------------------------------------------------------------------------------------------------------------------------------------------------------------------------------------------------------------------------------------------------------------------------------------------------------------------------------------------------------------------------------------------------------------------------------------------------------------------------------------------------------|
| <b>Step 1</b> | <b>enable</b><br><b>Example:</b><br>Router> <b>enable</b>                                                                                                                          | Enables privileged EXEC mode. <ul style="list-style-type: none"> <li>• Enter your password if prompted.</li> </ul>                                                                                                                                                                                                                                                                                                                                                                                             |
| <b>Step 2</b> | <b>configure terminal</b><br><b>Example:</b><br>Router# <b>configure terminal</b>                                                                                                  | Enters global configuration mode.                                                                                                                                                                                                                                                                                                                                                                                                                                                                              |
| <b>Step 3</b> | <b>interface bundle <i>bundle-no</i></b><br><b>Example:</b><br>Router(config)# <b>interface bundle 1</b>                                                                           | Enters interface configuration mode for the specified bundle interface.                                                                                                                                                                                                                                                                                                                                                                                                                                        |
| <b>Step 4</b> | <b>cable source-verify leasequery-filter upstream <i>threshold interval</i></b><br><b>Example:</b><br>Router(config-if)# <b>cable source-verify leasequery-filter upstream 2 5</b> | Enables leasequery filtering on all upstreams on the specified bundle interface, using the specified <i>threshold</i> and <i>interval</i> values. <p><b>Note</b> The <b>cable source-verify leasequery-filter upstream</b> command can only be configured under bundle interface.</p> <p><b>Note</b> Repeat step 3 and step 4 to enable the filtering of DHCP Leasequeries on the upstreams for other bundle interfaces. Primary and secondary interfaces in a cable bundle must be configured separately.</p> |
| <b>Step 5</b> | <b>end</b><br><b>Example:</b><br>Router(config-if)# <b>end</b>                                                                                                                     | Exits interface configuration mode and returns to privileged EXEC mode.                                                                                                                                                                                                                                                                                                                                                                                                                                        |

## Configuring Unitary DHCPv6 Leasequery Filtering

Use the following procedure to configure the Cisco CMTS router to send Leasequeries to a DHCP server to verify the authenticity of the IPv6 CPE. You can also enable filtering of these requests to prevent large volumes of Leasequery requests on the bundle interfaces. Similarly, the number of allowable Leasequery requests and the interval time period can also be configured.





**Note** When the leasequery timer expires, only the IPv4 static CPE is automatically removed from the host database.

### Before you begin

- Disable the IPv6 Neighbor Discovery (ND) Gleaning feature using the **no** form of the **cable nd** command in bundle interface configuration mode before configuring the unitary DHCPv6 leasequery protocol. For details on IPv6 ND gleaning, see [IPv6 on Cable](#) feature guide.
- Configure the **cable ipv6 source-verify dhcp** command under the Cisco CMTS bundle or bundle subinterface to enable the unitary DHCPv6 leasequery protocol.
- Use the **cable ipv6 source-verify dhcp [server ipv6-address]** command for a single DHCP server.
- *Use the **cable ipv6 source-verify dhcp** command without any keywords for multiple DHCP servers.*

### Procedure

|               | Command or Action                                                                                                                                                                                                                                      | Purpose                                                                                                                                                                                                                                                |
|---------------|--------------------------------------------------------------------------------------------------------------------------------------------------------------------------------------------------------------------------------------------------------|--------------------------------------------------------------------------------------------------------------------------------------------------------------------------------------------------------------------------------------------------------|
| <b>Step 1</b> | <b>enable</b><br><b>Example:</b><br><pre>Router&gt; enable</pre>                                                                                                                                                                                       | Enables privileged EXEC mode. <ul style="list-style-type: none"> <li>• Enter your password if prompted.</li> </ul>                                                                                                                                     |
| <b>Step 2</b> | <b>configure terminal</b><br><b>Example:</b><br><pre>Router# configure terminal</pre>                                                                                                                                                                  | Enters global configuration mode.                                                                                                                                                                                                                      |
| <b>Step 3</b> | <b>interface bundle <i>bundle-no</i></b><br><b>Example:</b><br><pre>Router(config)# interface bundle 1</pre>                                                                                                                                           | Enters interface configuration mode for the specified bundle interface.                                                                                                                                                                                |
| <b>Step 4</b> | <b>cable ipv6 source-verify</b> or <b>cable ipv6 source-verify dhcp</b><br>[server ipv6-address]<br><b>Example:</b><br><pre>Router(config-if)# cable ipv6 source-verify or Router(config-if)# cable ipv6 source-verify dhcp server 2001:DB8:1::1</pre> | Enables leasequery filtering on the specified bundle interface and verifies the IP address with multiple DHCPv6 servers. or Enables leasequery filtering on the specified bundle interface and verifies the IP address with a specified DHCPv6 server. |
| <b>Step 5</b> | <b>cable ipv6 source-verify leasetimer <i>value</i></b><br><b>Example:</b><br><pre>Router(config-if)# cable ipv6 source-verify</pre>                                                                                                                   | Enables leasequery timer on the specified bundle interface, for the Cisco CMTS to check its internal CPE database for IPv6 addresses whose lease time has expired.                                                                                     |

|               | Command or Action                                                                                                                                                        | Purpose                                                                 |
|---------------|--------------------------------------------------------------------------------------------------------------------------------------------------------------------------|-------------------------------------------------------------------------|
|               | <code>leasetimer 200</code>                                                                                                                                              |                                                                         |
| <b>Step 6</b> | <b>cable ipv6 source-verify leasequery-filter</b> <i>threshold interval</i><br><b>Example:</b><br><pre>Router(config-if)# cable ipv6 source-verify leasetimer 5 10</pre> | Enables filtering of the IPv6 leasequery requests.                      |
| <b>Step 7</b> | <b>end</b><br><b>Example:</b><br><pre>Router(config-if)# end</pre>                                                                                                       | Exits interface configuration mode and returns to privileged EXEC mode. |

## Enabling DHCPv6 Leasequery Filtering on Downstreams

Use the following procedure to start filtering DHCP Leasequeries on all downstreams of a cable interface.

### Procedure

|               | Command or Action                                                                                                                                                                   | Purpose                                                                                                                               |
|---------------|-------------------------------------------------------------------------------------------------------------------------------------------------------------------------------------|---------------------------------------------------------------------------------------------------------------------------------------|
| <b>Step 1</b> | <b>enable</b><br><b>Example:</b><br><pre>Router&gt; enable</pre>                                                                                                                    | Enables privileged EXEC mode. <ul style="list-style-type: none"> <li>• Enter your password if prompted.</li> </ul>                    |
| <b>Step 2</b> | <b>configure terminal</b><br><b>Example:</b><br><pre>Router# configure terminal</pre>                                                                                               | Enters global configuration mode.                                                                                                     |
| <b>Step 3</b> | <b>cable ipv6 source-verify leasequery-filter downstream</b> <i>threshold interval</i><br><b>Example:</b><br><pre>Router(config-if)# cable ipv6 source-verify leasetimer 5 10</pre> | Enables leasequery filtering on all downstreams on the specified bundle interface, using the specified threshold and interval values: |
| <b>Step 4</b> | <b>end</b><br><b>Example:</b>                                                                                                                                                       | Exits interface configuration mode and returns to privileged EXEC mode.                                                               |

|  | Command or Action             | Purpose |
|--|-------------------------------|---------|
|  | Router(config-if)# <b>end</b> |         |

## Configuration Examples for Filtering of DHCP Leasequery

This section provides the following examples on how to configure the DHCP leasequery filtering feature:

### Example: DHCP Leasequery Filtering

The following example shows an excerpt from a typical configuration of a bundle interface that is configured for filtering DHCP leasequery requests on both its upstream and downstream interfaces:



**Note** If an alternate server has been configured to receive leasequery requests, the **cable source-verify dhcp server ipaddress command** would display in place of the **cable source-verify dhcp** command below.

```
.
.
.
cable source-verify leasequery-filter downstream 5 20
.
.
.
interface bundle 1
.
.
.
cable source-verify dhcp
cable source-verify leasequery-filter upstream 1 5
no cable arp
.
.
```

### Example: Unitary DHCPv6 Leasequery Filtering

The following example shows how to display the total number of DHCPv6 leasequery requests that have been filtered on the router in Cisco IOS Release 12.2(33)SCF1:

```
Router# show cable leasequery-filter
IPv4 Lease Query Filter statistics for Unknown Sid
Requests Sent : 0 total. 0 unfiltered, 0 filtered
IPv6 Lease Query Filter statistics for Unknown Sid
Requests Sent : 0 total. 0 unfiltered, 0 filtered
```

## Additional References

### Technical Assistance

| Description                                                                                                                                                                                                                                                                                                                                                                                                                                                                                                                                                             | Link                                                                    |
|-------------------------------------------------------------------------------------------------------------------------------------------------------------------------------------------------------------------------------------------------------------------------------------------------------------------------------------------------------------------------------------------------------------------------------------------------------------------------------------------------------------------------------------------------------------------------|-------------------------------------------------------------------------|
| <p>The Cisco Support website provides extensive online resources, including documentation and tools for troubleshooting and resolving technical issues with Cisco products and technologies.</p> <p>To receive security and technical information about your products, you can subscribe to various services, such as the Product Alert Tool (accessed from Field Notices), the Cisco Technical Services Newsletter, and Really Simple Syndication (RSS) Feeds.</p> <p>Access to most tools on the Cisco Support website requires a Cisco.com user ID and password.</p> | <a href="http://www.cisco.com/support">http://www.cisco.com/support</a> |

## Feature Information for Cable DHCP Leasequery

Use Cisco Feature Navigator to find information about the platform support and software image support. Cisco Feature Navigator enables you to determine which software images support a specific software release, feature set, or platform. To access Cisco Feature Navigator, go to the <https://cfnng.cisco.com/> link. An account on the Cisco.com page is not required.



**Note** The following table lists the software release in which a given feature is introduced. Unless noted otherwise, subsequent releases of that software release train also support that feature.

*Table 225: Feature Information for Cable DHCP Leasequery*

| Feature Name          | Releases                 | Feature Information                                                                                            |
|-----------------------|--------------------------|----------------------------------------------------------------------------------------------------------------|
| Cable DHCP leasequery | Cisco IOS XE Fuji 16.7.1 | This feature was integrated into Cisco IOS XE Fuji 16.7.1 on the Cisco cBR Series Converged Broadband Routers. |



## CHAPTER 64

# DHCPv6 Bulk-Lease query

---

This document describes the Dynamic Host Configuration Protocol (DHCP) v6 Bulk-Lease query feature on the Cisco cable modem termination system (CMTS) router.

Your software release may not support all the features that are documented in this module. For the latest feature information and caveats, see the release notes for your platform and software release. The Feature Information Table at the end of this document provides information about the documented features and lists the releases in which each feature is supported.

Use Cisco Feature Navigator to find information about platform support and Cisco software image support. To access Cisco Feature Navigator, go to <http://tools.cisco.com/ITDIT/CFN/>. An account on <http://www.cisco.com/> is not required.

- [Hardware Compatibility Matrix for the Cisco cBR Series Routers, on page 1081](#)
- [Information About DHCPv6 Bulk-Lease Query, on page 1083](#)
- [How to Configure DHCPv6 Bulk-Lease Query, on page 1083](#)
- [Debugging DHCPv6 Bulk-Lease Query, on page 1084](#)
- [Feature Information for DHCPv6 Bulk-Lease query, on page 1084](#)

## Hardware Compatibility Matrix for the Cisco cBR Series Routers



---

**Note** The hardware components that are introduced in a given Cisco IOS-XE Release are supported in all subsequent releases unless otherwise specified.

---

Table 226: Hardware Compatibility Matrix for the Cisco cBR Series Routers

| Cisco CMTS Platform                    | Processor Engine                                                                                                                                                                                  | Interface Cards                                                                                                                                                                                                                                                                                                                                                                                                                                                                                                                                                                                                                                                                                                                                                                                 |
|----------------------------------------|---------------------------------------------------------------------------------------------------------------------------------------------------------------------------------------------------|-------------------------------------------------------------------------------------------------------------------------------------------------------------------------------------------------------------------------------------------------------------------------------------------------------------------------------------------------------------------------------------------------------------------------------------------------------------------------------------------------------------------------------------------------------------------------------------------------------------------------------------------------------------------------------------------------------------------------------------------------------------------------------------------------|
| Cisco cBR-8 Converged Broadband Router | <p><b>Cisco IOS-XE Release 16.5.1 and Later Releases</b></p> <p>Cisco cBR-8 Supervisor:</p> <ul style="list-style-type: none"> <li>• PID—CBR-SUP-250G</li> <li>• PID—CBR-CCAP-SUP-160G</li> </ul> | <p><b>Cisco IOS-XE Release 16.5.1 and Later Releases</b></p> <p>Cisco cBR-8 CCAP Line Cards:</p> <ul style="list-style-type: none"> <li>• PID—CBR-LC-8D30-16U30</li> <li>• PID—CBR-LC-8D31-16U30</li> <li>• PID—CBR-RF-PIC</li> <li>• PID—CBR-RF-PROT-PIC</li> <li>• PID—CBR-CCAP-LC-40G</li> <li>• PID—CBR-CCAP-LC-40G-R</li> <li>• PID—CBR-CCAP-LC-G2-R</li> <li>• PID—CBR-SUP-8X10G-PIC</li> <li>• PID—CBR-2X100G-PIC</li> </ul> <p>Digital PICs:</p> <ul style="list-style-type: none"> <li>• PID—CBR-DPIC-8X10G</li> <li>• PID—CBR-DPIC-2X100G</li> </ul> <p>Cisco cBR-8 Downstream PHY Module:</p> <ul style="list-style-type: none"> <li>• PID—CBR-D31-DS-MOD</li> </ul> <p>Cisco cBR-8 Upstream PHY Modules:</p> <ul style="list-style-type: none"> <li>• PID—CBR-D31-US-MOD</li> </ul> |



**Note** Do not use DPICs (8X10G and 2x100G) to forward IP traffic, as it may cause buffer exhaustion, leading to line card reload.

The only allowed traffic on a DPIC interface is DEPI, UEPI, and GCP traffic from the Cisco cBR-8 router to Remote PHY devices. Other traffic such as DHCP, SSH, and UTSC should flow via another router, since DPICs cannot be used for normal routing.

## Information About DHCPv6 Bulk-Lease Query

This document describes the Dynamic Host Configuration Protocol (DHCP) v6 bulk-lease query feature on the Cisco cable modem termination system (CMTS) router. Cisco cBR-8 supports DHCPv6 bulk lease query in accordance with RFC 5460.

DHCPv6 bulk lease query is used to recover the IPv6 bindings(GUA/PD/LLA) for CPE ONLY after a chassis reload. The CPE's IPv6 binding information is retrieved from the DHCPv6 server. On cBR8, this feature is designed to be started some time later after a chassis reload. Since before recover CPE's information, we must wait its CM online firstly.

cBR8 will check all active CPE IPv6 bindings retrieved from DHCPv6 server one by one:

- If the IPv6 binding is for CM, cBR8 will drop it.
- If the IPv6 binding is for a CPE. If this binding does not present on cBR8 side and the CM of the CPE is online, cBR8 will recover the IPv6 binding, otherwise, cBR8 will drop it.

The DHCPv6 bulk-lease query feature is disabled by default.

To make this feature works, the DHCPv6 server side must also support DHCPv6 bulk lease query.

## How to Configure DHCPv6 Bulk-Lease Query

The following steps help you to setup the DHCPv6 Bulk-Lease query feature with Cisco cBR-8 Converged Broadband Router.

To enable the DHCPv6 Bulk-Lease query feature, run the following commands:

1. Run the **[no] ipv6 dhcp-relay bulk-lease disable** command.
2. Run the **cable ipv6 source-verify bulk-lease [start <start-seconds> timeout <timeout-seconds>]** command.



---

**Note** The start-seconds means the time DHCPv6 Bulk-lease will be started after common reload. The start-seconds default value is 2400 seconds. The timeout-seconds means the max time that DHCPv6 Bulk-lease allowed to run. The timeout-seconds default value is 600 seconds.

---

Ensure that you enable both the Cisco common and Cable specific parts.

To disable the DHCPv6 Bulk-Lease query feature, run the following commands:

1. Run the **ipv6 dhcp-relay bulk-lease disable** command.
2. Run the **[no] cable ipv6 source-verify bulk-lease** command.



---

**Note** The DHCPv6 server needs to listen on the TCP port 547.

---

## Debugging DHCPv6 Bulk-Lease Query

The following debugging commands are supported for the DHCPv6 Bulk-Lease Query:

- `debug cable ipv6 bulk-lq`
- `debug ipv6 dhcp relay bulk-lease`

To check the results of DHCPv6 Bulk-Lease query, you can use the `debug cable ipv6 bulk-lq` command. See the following example:

```
Router# show cable ipv6 bulk-lq
CMTS DHCPv6 Bulk Lease Query Statistics:
  Start time 1200 seconds after system up
  End time 1500 seconds after system up
  DHCPv6 Bulk Lease Query glean ready: 0
  DHCPv6 Bulk Lease Query process created: 0
  Time out happened: No
  Total number of CM option received: 31
  Total number of LLA received: 10
  Total number of LLA recovered: 7
  Total number of GUA received: 10
  Total number of GUA recovered: 8
  Total number of PD received: 0
  Total number of PD recovered: 0
```

## Feature Information for DHCPv6 Bulk-Lease query

Use Cisco Feature Navigator to find information about the platform support and software image support. Cisco Feature Navigator enables you to determine which software images support a specific software release, feature set, or platform. To access Cisco Feature Navigator, go to the <https://cfngng.cisco.com/> link. An account on the Cisco.com page is not required.



**Note** The following table lists the software release in which a given feature is introduced. Unless noted otherwise, subsequent releases of that software release train also support that feature.

*Table 227: Feature Information for DHCPv6 Bulk-Lease query*

| Feature Name            | Releases                       | Feature Information                                                                                                  |
|-------------------------|--------------------------------|----------------------------------------------------------------------------------------------------------------------|
| DHCPv6 Bulk-Lease query | Cisco IOS XE Gibraltar 16.12.1 | This feature was integrated into Cisco IOS XE Gibraltar 16.12.1 on the Cisco cBR Series Converged Broadband Routers. |





## CHAPTER 65

# Layer 3 CPE Mobility

---

Layer 3 CPE Mobility feature is introduced to allow the mobility CPE devices to move between cable modems with as little disruption of traffic as possible.

Your software release may not support all the features that are documented in this module. For the latest feature information and caveats, see the release notes for your platform and software release. The Feature Information Table at the end of this document provides information about the documented features and lists the releases in which each feature is supported.

Use Cisco Feature Navigator to find information about platform support and Cisco software image support. To access Cisco Feature Navigator, go to <http://tools.cisco.com/ITDIT/CFN/>. An account on <http://www.cisco.com/> is not required.

### Contents

- [Hardware Compatibility Matrix for the Cisco cBR Series Routers](#), on page 1085
- [Prerequisites for Layer 3 CPE Mobility](#), on page 1086
- [Restrictions for Layer 3 CPE Mobility](#), on page 1087
- [Information About Layer 3 CPE Mobility](#), on page 1087
- [How to Configure Layer 3 Mobility](#), on page 1088
- [Configuration Examples for Layer 3 Mobility](#), on page 1091
- [Additional References](#), on page 1092
- [Feature Information for Layer 3 CPE Mobility](#), on page 1092

## Hardware Compatibility Matrix for the Cisco cBR Series Routers



---

**Note** The hardware components that are introduced in a given Cisco IOS-XE Release are supported in all subsequent releases unless otherwise specified.

---

Table 228: Hardware Compatibility Matrix for the Cisco cBR Series Routers

| Cisco CMTS Platform                    | Processor Engine                                                                                                                                                                                  | Interface Cards                                                                                                                                                                                                                                                                                                                                                                                                                                                                                                                                                                                                                                                                                                                                                                                 |
|----------------------------------------|---------------------------------------------------------------------------------------------------------------------------------------------------------------------------------------------------|-------------------------------------------------------------------------------------------------------------------------------------------------------------------------------------------------------------------------------------------------------------------------------------------------------------------------------------------------------------------------------------------------------------------------------------------------------------------------------------------------------------------------------------------------------------------------------------------------------------------------------------------------------------------------------------------------------------------------------------------------------------------------------------------------|
| Cisco cBR-8 Converged Broadband Router | <p><b>Cisco IOS-XE Release 16.5.1 and Later Releases</b></p> <p>Cisco cBR-8 Supervisor:</p> <ul style="list-style-type: none"> <li>• PID—CBR-SUP-250G</li> <li>• PID—CBR-CCAP-SUP-160G</li> </ul> | <p><b>Cisco IOS-XE Release 16.5.1 and Later Releases</b></p> <p>Cisco cBR-8 CCAP Line Cards:</p> <ul style="list-style-type: none"> <li>• PID—CBR-LC-8D30-16U30</li> <li>• PID—CBR-LC-8D31-16U30</li> <li>• PID—CBR-RF-PIC</li> <li>• PID—CBR-RF-PROT-PIC</li> <li>• PID—CBR-CCAP-LC-40G</li> <li>• PID—CBR-CCAP-LC-40G-R</li> <li>• PID—CBR-CCAP-LC-G2-R</li> <li>• PID—CBR-SUP-8X10G-PIC</li> <li>• PID—CBR-2X100G-PIC</li> </ul> <p>Digital PICs:</p> <ul style="list-style-type: none"> <li>• PID—CBR-DPIC-8X10G</li> <li>• PID—CBR-DPIC-2X100G</li> </ul> <p>Cisco cBR-8 Downstream PHY Module:</p> <ul style="list-style-type: none"> <li>• PID—CBR-D31-DS-MOD</li> </ul> <p>Cisco cBR-8 Upstream PHY Modules:</p> <ul style="list-style-type: none"> <li>• PID—CBR-D31-US-MOD</li> </ul> |



**Note** Do not use DPICs (8X10G and 2x100G) to forward IP traffic, as it may cause buffer exhaustion, leading to line card reload.

The only allowed traffic on a DPIC interface is DEPI, UEPI, and GCP traffic from the Cisco cBR-8 router to Remote PHY devices. Other traffic such as DHCP, SSH, and UTSC should flow via another router, since DPICs cannot be used for normal routing.

## Prerequisites for Layer 3 CPE Mobility

No special equipment or software is needed to use the Layer 3 CPE Mobility feature.

## Restrictions for Layer 3 CPE Mobility

- Layer 3 CPE Mobility feature allows CPE devices to move only in the same bundle or sub-bundle interface.
- The IPv4 or IPv6 subnets that are configured with mobility must match with the IPv4 or IPv6 subnets already configured on bundle or sub-bundle interface. Otherwise, configuration will not be accepted and the following message will be displayed:

Please remove the previous online CPEs or reset CMs,

- If you remove the IPv4 or IPv6 address on bundle or sub-bundle interface, it also removes the relative mobility subnets at the same time.
- Multicast packets will not trigger the Layer 3 CPE Mobility feature.
- VRF configured under bundle or sub-bundle interface is not supported for CPE mobility feature.
- In Layer 3 CPE Mobility feature, the packet lost time period during mobility will be unpredictable, depending on how many CPE devices move at the same time and system loading conditions.
- For CPE devices, which have multiple IPv4 or IPv6 addresses, all of IPv4 or IPv6 addresses will be rebuilt with new source information.
- Layer 3 CPE Mobility may be failed during line card or SUP HA and the trigger upstream packet will be dropped.
- If CPE mobility is turned on, mobility behavior will become effective before cable Ipv4 or IPv6 source verify.
- If Layer 3 CPE Mobility is enabled, some of the security checks will be skipped for the mobility subnets to achieve faster movement of the CPE devices.

## Information About Layer 3 CPE Mobility

The Layer 3 CPE Mobility feature allows CPE devices to move from cable modem to other by trigger of any unicast upstream packets of IPv4 or IPV6.

Each cable modem would be situated at a business hotspot location and the CPE devices move from one business location to another, where the service provider is the same and the head end CMTS is the same. This mobility is allowed for selected IP subnets.

The IPv4 or IPv6 subnets that are configured with mobility must match with the IPv4 or IPv6 subnets already configured on bundle or sub-bundle interface. Otherwise, configuration will not be accepted and the following message will be displayed:

Please remove the previous online CPEs or reset CMs,

When you remove mobility subnets under bundle or sub-bundle interface. The following warning message will be displayed after mobility subnets is configured or removed.

Warning: Please remove the previous online CPEs or reset CMs, to make the mobility scope change works for every device !!!



**Note** If you have enabled mobility configuration for a subnet, the existing online CPE devices will be updated to aware of the mobility subnets, and the CPU usage will rise up during that time. So it's better to configure the mobility subnets before CM and CPE come online.

Enabling the Layer 3 CPE Mobility feature may, in certain situations, cause excessive punted packets. By default, the Source-Based Rate-Limiting (SBRL) feature rate-limits these punted packets to avoid CPU overload.

## Benefits of Layer 3 CPE Mobility

The feature provides the movement of CPE devices from one cable modem to another without change in the IP address and the TCP or UDP sessions established are maintained.

# How to Configure Layer 3 Mobility

## Configuring CPE Mobility

This section describes how to enable mobility on a particular IP subnet on a interface or subinterface bundle.

### Before you begin

Mobility subnets should match the IPv4 or IPv6 address configured on the bundle or sub-bundle interface.

### Procedure

|               | Command or Action                                                                                                                                                                   | Purpose                                                        |
|---------------|-------------------------------------------------------------------------------------------------------------------------------------------------------------------------------------|----------------------------------------------------------------|
| <b>Step 1</b> | <b>enable</b><br><b>Example:</b><br><br>Router> <b>enable</b>                                                                                                                       | Enables privileged EXEC mode. Enter your password if prompted. |
| <b>Step 2</b> | <b>configure terminal</b><br><b>Example:</b><br><br>Router# <b>configure terminal</b>                                                                                               | Enters global configuration mode.                              |
| <b>Step 3</b> | <b>interface bundle bundle number  bundle-subif-number</b><br><b>Example:</b><br><br>Router(config)# <b>interface bundle 1</b><br>or<br>Router(config)# <b>interface Bundle 1.1</b> | Enters interface configuration or subinterface mode.           |
| <b>Step 4</b> | <b>cable l3-mobility IP-address mask   IPv6 prefix</b>                                                                                                                              | Enables mobility for a particular IPv4 or IPv6 subnet.         |

|               | Command or Action                                                                                                                                                                                                                                                                       | Purpose                                                                                    |
|---------------|-----------------------------------------------------------------------------------------------------------------------------------------------------------------------------------------------------------------------------------------------------------------------------------------|--------------------------------------------------------------------------------------------|
|               | <p><b>Example:</b></p> <pre>Router(config-if)# cable l3-mobility 2001:DB:22:1::1/64</pre> <p><b>Example:</b></p> <pre>Router(config-subif)# cable l3-mobility 192.0.3.1 255.255.255.0</pre> <p><b>Example:</b></p> <pre>Router(config-subif)#cable l3-mobility 2001:DB:22:1::1/64</pre> | <p><b>Note</b> This command can be configured on a interface or a subinterface bundle.</p> |
| <b>Step 5</b> | <p><b>exit</b></p> <p><b>Example:</b></p> <pre>Router(config-if)# exit</pre>                                                                                                                                                                                                            | Exits interface configuration mode.                                                        |

### What to do next

### Troubleshooting Tips

If the mobility IP address does not match with the mobility subnet, the following warning message is displayed:

```
Mobility IP should match the IDB subnet!
```

If you remove the IPv4 or IPv6 address from the interface, the mobility scope is removed for the IP address and the following warning message is displayed.

```
IPv6 2001:DBB:3:111::1 removed from Mobility subnets on Bundle1
```

## Configure Source-Based Rate Limit (SBRL) for L3-mobility

This section describes how to configure Source-Based Rate Limit (SBRL) for the L3-mobility feature. This procedure is optional and if not configured, the default SBRL configuration will apply.



**Note** SBRL for L3-mobility is enabled by default, so this configuration is optional.

Subscriber-side SBRL has a global and per-punt-cause configuration. L3-mobility punts are only subject to the per-punt-cause configuration. Traffic streams are identified by hashing the punt-cause and the source-MAC-address. This value is used as the index for rate-limiting. There is no special processing for hash-collisions, so hash-colliding streams are treated as if they are the same stream.

The default rate for L3-mobility punts is 4 packets per second.

**Before you begin**

**Note** All punted packets are subject to CoPP and the punt-policer.

**Procedure**

|               | Command or Action                                                                                                                                                                  | Purpose                                                        |
|---------------|------------------------------------------------------------------------------------------------------------------------------------------------------------------------------------|----------------------------------------------------------------|
| <b>Step 1</b> | <b>enable</b><br><b>Example:</b><br>Router> <b>enable</b>                                                                                                                          | Enables privileged EXEC mode. Enter your password if prompted. |
| <b>Step 2</b> | <b>configure terminal</b><br><b>Example:</b><br>Router# <b>configure terminal</b>                                                                                                  | Enters global configuration mode.                              |
| <b>Step 3</b> | <b>platform punt-sbri subscriber punt-cause <i>punt-cause</i> rate <i>rate</i></b><br><b>Example:</b><br>Router(config)# <b>platform punt-sbri subscriber punt-cause 99 rate 8</b> | Configures Subscriber-MAC-address SBRL.                        |
| <b>Step 4</b> | <b>exit</b><br><b>Example:</b><br>Router(config-if)# <b>exit</b>                                                                                                                   | Exits global configuration mode.                               |

## Disabling CPE Mobility

This section describes how to disable mobility on a particular IP subnet.

**Before you begin**

The CPE mobility should be enabled on a particular IP subnet before you complete this procedure.

**Procedure**

|               | Command or Action                                         | Purpose                                                        |
|---------------|-----------------------------------------------------------|----------------------------------------------------------------|
| <b>Step 1</b> | <b>enable</b><br><b>Example:</b><br>Router> <b>enable</b> | Enables privileged EXEC mode. Enter your password if prompted. |

|        | Command or Action                                                                                                                                                                                                                       | Purpose                                                                                                                                       |
|--------|-----------------------------------------------------------------------------------------------------------------------------------------------------------------------------------------------------------------------------------------|-----------------------------------------------------------------------------------------------------------------------------------------------|
| Step 2 | <b>configure terminal</b><br><b>Example:</b><br>Router# <b>configure terminal</b>                                                                                                                                                       | Enters global configuration mode.                                                                                                             |
| Step 3 | <b>interface bundle</b> <i>bundle number</i>   <i>bundle-subif-number</i><br><b>Example:</b><br>Router(config)# <b>interface bundle 1</b><br>or<br>Router(config)# <b>interface Bundle 1.1</b>                                          | Enters interface configuration or subinterface mode.                                                                                          |
| Step 4 | <b>no cable l3-mobility</b> <i>IP-address mask</i>   <i>IPv6 prefix</i><br><b>Example:</b><br>Router(config-if)# <b>cable l3-mobility 192.0.3.1 255.255.255.0</b><br><br>Router(config-if)# <b>cable l3-mobility 2001:DB:22:1::1/64</b> | Disables mobility for a particular IPv4 or IPv6 subnet.<br><b>Note</b> This command can be configured on a interface or a subinterface bundle |
| Step 5 | <b>exit</b><br><b>Example:</b><br>Router(config-if)# <b>exit</b>                                                                                                                                                                        | Exits interface configuration mode.                                                                                                           |

## Verifying Layer 3 Mobility Configuration

To verify the layer 3 mobility configuration, use the **show cable bundle** command.

## Configuration Examples for Layer 3 Mobility

This section provides the following configuration examples:

### Example: Configuring CPE Layer 3 Mobility

The following example shows how to configure the layer 3 CPE mobility on a interface bundle:

```
Router#show running interface bundle 10
Building configuration...
Current configuration : 1247 bytes
!
interface Bundle10
ip address 192.0.3.1 255.255.255.0 secondary
ip address 192.2.21.1 255.255.255.0 secondary
ip address 192.3.23.1 255.255.255.0
ip pim sparse-dense-mode
```

```

ip igmp static-group 231.1.1.1
no cable arp filter request-send
no cable arp filter reply-accept
cable l3-mobility 192.0.3.1 255.255.255.0
cable l3-mobility 192.2.21.1 255.255.255.0
cable l3-mobility 192.3.23.1 255.255.255.0
cable l3-mobility 2001:DB:26:1::1/64
cable l3-mobility 2001:DB:27:1::1/96
cable dhcp-giaddr primary
cable helper-address 20.1.0.3
ipv6 address 2001:DB:26:1::1/64
ipv6 address 2001:DB:27:1::1/96
ipv6 enable
ipv6 nd reachable-time 3600000
ipv6 nd managed-config-flag
ipv6 nd other-config-flag
ipv6 dhcp relay destination 2001:DB:1:1:214:4FFF:FEA9:5863
end

```

## Example: Configuring SBRL for L3-mobility

The following example shows how SBRL is configured for L3-mobility:

```

Router# show run | i punt-sbri
platform punt-sbri subscriber punt-cause 99 rate 8

```

## Additional References

The following sections provide references related to Layer 3 CPE Mobility feature for the Cisco CMTS routers.

### Technical Assistance

| Description                                                                                                                                                                                                                                                                                                                                                                           | Link                                                                                                              |
|---------------------------------------------------------------------------------------------------------------------------------------------------------------------------------------------------------------------------------------------------------------------------------------------------------------------------------------------------------------------------------------|-------------------------------------------------------------------------------------------------------------------|
| The Cisco Support and Documentation website provides online resources to download documentation, software, and tools. Use these resources to install and configure the software and to troubleshoot and resolve technical issues with Cisco products and technologies. Access to most tools on the Cisco Support and Documentation website requires a Cisco.com user ID and password. | <a href="http://www.cisco.com/cisco/web/support/index.html">http://www.cisco.com/cisco/web/support/index.html</a> |

## Feature Information for Layer 3 CPE Mobility

Use Cisco Feature Navigator to find information about the platform support and software image support. Cisco Feature Navigator enables you to determine which software images support a specific software release, feature set, or platform. To access Cisco Feature Navigator, go to the <https://cfng.cisco.com/> link. An account on the Cisco.com page is not required.





**Note** The following table lists the software release in which a given feature is introduced. Unless noted otherwise, subsequent releases of that software release train also support that feature.

**Table 229: Feature Information for Layer 3 CPE Mobility**

| Feature Name     | Releases                 | Feature Information                                                                                            |
|------------------|--------------------------|----------------------------------------------------------------------------------------------------------------|
| Layer 3 Mobility | Cisco IOS XE Fuji 16.7.1 | This feature was integrated into Cisco IOS XE Fuji 16.7.1 on the Cisco cBR Series Converged Broadband Routers. |





## CHAPTER 66

# DOCSIS 3.0 Multicast Support

The Cisco cBR Series Routers support multicast improvements based on Data-over-Cable Service Interface Specifications (DOCSIS) 3.0. DOCSIS 3.0 multicast support improves bandwidth efficiency and allows service providers to offer differentiated quality of service for different types of traffic.

Your software release may not support all the features that are documented in this module. For the latest feature information and caveats, see the release notes for your platform and software release. The Feature Information Table at the end of this document provides information about the documented features and lists the releases in which each feature is supported.

Use Cisco Feature Navigator to find information about platform support and Cisco software image support. To access Cisco Feature Navigator, go to <http://tools.cisco.com/ITDIT/CFN/>. An account on <http://www.cisco.com/> is not required.

### Contents

- [Hardware Compatibility Matrix for the Cisco cBR Series Routers, on page 1095](#)
- [Prerequisites for the DOCSIS 3.0 Multicast Support, on page 1096](#)
- [Restrictions for the DOCSIS 3.0 Multicast Support, on page 1097](#)
- [Information About the DOCSIS 3.0 Multicast Support, on page 1097](#)
- [How to Configure the DOCSIS 3.0 Multicast Support, on page 1102](#)
- [Configuring Multicast Replication Session Globally, on page 1110](#)
- [Configuring Multicast Replication Sessions on Forwarding Interface, on page 1110](#)
- [Clearing Multicast Replication Cache, on page 1111](#)
- [How to Monitor the DOCSIS 3.0 Multicast Support, on page 1111](#)
- [Configuration Examples for DOCSIS 3.0 Multicast Support, on page 1116](#)
- [Additional References, on page 1117](#)
- [Feature Information for DOCSIS 3.0 Multicast Support, on page 1119](#)

## Hardware Compatibility Matrix for the Cisco cBR Series Routers



**Note** The hardware components that are introduced in a given Cisco IOS-XE Release are supported in all subsequent releases unless otherwise specified.

Table 230: Hardware Compatibility Matrix for the Cisco cBR Series Routers

| Cisco CMTS Platform                    | Processor Engine                                                                                                                                                                                  | Interface Cards                                                                                                                                                                                                                                                                                                                                                                                                                                                                                                                                                                                                                                                                                                                                                                                 |
|----------------------------------------|---------------------------------------------------------------------------------------------------------------------------------------------------------------------------------------------------|-------------------------------------------------------------------------------------------------------------------------------------------------------------------------------------------------------------------------------------------------------------------------------------------------------------------------------------------------------------------------------------------------------------------------------------------------------------------------------------------------------------------------------------------------------------------------------------------------------------------------------------------------------------------------------------------------------------------------------------------------------------------------------------------------|
| Cisco cBR-8 Converged Broadband Router | <p><b>Cisco IOS-XE Release 16.5.1 and Later Releases</b></p> <p>Cisco cBR-8 Supervisor:</p> <ul style="list-style-type: none"> <li>• PID—CBR-SUP-250G</li> <li>• PID—CBR-CCAP-SUP-160G</li> </ul> | <p><b>Cisco IOS-XE Release 16.5.1 and Later Releases</b></p> <p>Cisco cBR-8 CCAP Line Cards:</p> <ul style="list-style-type: none"> <li>• PID—CBR-LC-8D30-16U30</li> <li>• PID—CBR-LC-8D31-16U30</li> <li>• PID—CBR-RF-PIC</li> <li>• PID—CBR-RF-PROT-PIC</li> <li>• PID—CBR-CCAP-LC-40G</li> <li>• PID—CBR-CCAP-LC-40G-R</li> <li>• PID—CBR-CCAP-LC-G2-R</li> <li>• PID—CBR-SUP-8X10G-PIC</li> <li>• PID—CBR-2X100G-PIC</li> </ul> <p>Digital PICs:</p> <ul style="list-style-type: none"> <li>• PID—CBR-DPIC-8X10G</li> <li>• PID—CBR-DPIC-2X100G</li> </ul> <p>Cisco cBR-8 Downstream PHY Module:</p> <ul style="list-style-type: none"> <li>• PID—CBR-D31-DS-MOD</li> </ul> <p>Cisco cBR-8 Upstream PHY Modules:</p> <ul style="list-style-type: none"> <li>• PID—CBR-D31-US-MOD</li> </ul> |



**Note** Do not use DPICs (8X10G and 2x100G) to forward IP traffic, as it may cause buffer exhaustion, leading to line card reload.

The only allowed traffic on a DPIC interface is DEPI, UEPI, and GCP traffic from the Cisco cBR-8 router to Remote PHY devices. Other traffic such as DHCP, SSH, and UTSC should flow via another router, since DPICs cannot be used for normal routing.

## Prerequisites for the DOCSIS 3.0 Multicast Support

- DOCSIS 3.0-compliant Cisco CMTS and DOCSIS 3.0-enabled cable modems are required.

- Cisco CMTS must be MDF-enabled by default.
- Quality of service (QoS) parameters must be configured for various multicast sessions.

## Restrictions for the DOCSIS 3.0 Multicast Support

- You cannot disable explicit tracking.
- For multicast QoS, you must define three objects and templates, Service-Class, Group-QoS-Config (GQC), and Group-Config, and associate them to a particular bundle or forwarding interface.
- You must define a default service class and GQC before defining objects and templates.
- Static multicast feature is always enabled and you cannot disable it.
- The service flow attribute-based selection will be ignored if the group configuration is configured on the default forwarding interface.
- The multicast DSID feature is supported only on DOCSIS 3.0-compliant cable modems.
- The cable multicast mdf-disable wb-incapable-cm command disables multicast downstream service identifier (DSID) forwarding capability on the cable modem, which impacts the DSID capability between the Cisco CMTS and the cable modem.
- The multicast traffic to CPE increases two-fold after changing the multicast QoS configuration or the service-flow attribute during an active session. The traffic replication will continue till the default session timeout period (180 seconds). After the session timeout, the multicast DSID is removed from both Cisco CMTS and CM, and normal multicast traffic flow is resumed.
- For the DOCSIS 3.0 Multicast support feature to function properly, the CPE and the CM must be in the same virtual routing and forwarding (VRF) interface.

## Information About the DOCSIS 3.0 Multicast Support

IP multicast, an integral technology in networked applications, is the transmission of the same information to multiple recipients. Any network application, including cable networks, can benefit from the bandwidth efficiency of multicast technology. Two new technologies—Channel Bonding and Single Source Multicast (SSM)—are expected to dramatically accelerate multicast deployment.

The channel bonding and SSM technologies dramatically increase the operational efficiency of the existing hybrid fiber-coaxial (HFC) network. Using the multicast improvements, the cable operators can seamlessly deliver advanced services like video on demand (VoD), internet protocol television (IPTV), and facilitate interactive video and audio, and data services.

The following sections explain the benefits of DOCSIS 3.0 Multicast Support:

### Multicast DSID Forwarding

DOCSIS 3.0 multicast support introduces centralized control at the Cisco CMTS to provide flexibility and scalability to support a large array of multicast protocols. It replaces the Internet Group Management Protocol (IGMP), version 2 snooping infrastructure, which was part of the DOCSIS 1.1 and 2.0 models. Now, the Cisco

CMTS allocates a unique Downstream Service Identifier (DSID) to identify every multicast stream. These DSIDs are sent to the CMs that use these DSIDs to filter and forward Multicast traffic to the CPEs.

The multicast DSID forwarding (MDF) provides the following benefits:

- Unique identification of packet stream across bonding group within a MAC domain.
- Designation of packet stream as either Any Source Multicast (ASM) or Source Specific Multicast (SSM) per multicast channel.
- Implementation of multicast DSID management on the Route Processor (RP) makes it operate on a standalone basis.
- Snooping of all upstream signal control packets by the Cisco CMTS to find the customer premises equipment (CPE) on the Multicast DSID-based Forwarding (MDF) enabled CM and allocates DSID from the pool.
- Transmission of allocated DSIDs to the CM through Dynamic Bonding Change (DBC) message.
- Reuse of DSIDs on other MDF-enabled CMs in the same bonding group, joining the multicast session.
- Removal of DSIDs from the CM through a DBC message by the Cisco CMTS after a multicast session leave event.
- Release of DSID to the pool by the Cisco CMTS when the last member leaves the bonding group.
- The following DSIDs are preallocated for each primary downstream (modular and integrated cable interfaces) to forward general query messages. These DSIDs form part of the multicast group signaling protocol. Other multicast groups, do not use these DSIDs.
  - IGMPv2 general query (IPv4)
  - IGMPv3 general query (IPv4)
  - MLDv1 general query (IPv6)
  - MLDv2 general query (IPv6)
  - Preregistration of DSID (IPv6)
- Allocation of DSID ensures traffic segregation between virtual private networks (VPNs) for DOCSIS 3.0 MDF-enabled CMs. For example, two clients from two VPNs joining the same multicast will get two distinct DSIDs.

## Multicast Forwarding on Bonded CM

Multicast packets to the DOCSIS 3.0-enabled CMs are transmitted as bonded packets with DSID extension header on the primary bonding group if the Secondary Multicast Bonding Group is disabled. Multicast packets for MDF-disabled or pre-DOCSIS 3.0 CMs are transmitted as non-bonded without DSID extension header. For more information on this feature, refer to [Multicast Secondary Bonding Group, on page 1100](#).

In a network, where only MDF-enabled or MDF-disabled CMs exist, the traffic is segregated using field types. The MDF-enabled CM forwards the frame with the field type and the MDF-disabled CM drops it. The DSID labeling ensures that MDF-enabled CM gets a copy of the multicast session to prevent “cross talk”.

For hybrid CMs (MDF-enabled and MDF-disabled CMs) that do not support field type forwarding, you should configure per session encryption or security association identifier (SAID) isolation to ensure traffic segregation. DOCSIS 3.0 mandates that if the hybrid CM fails to forward field type frames, the Cisco CMTS should employ multicast security association identifier (MSAID) isolation. This isolation is achieved by assigning different MSAID to each replication, one to bonded CM and another to the non-bonded or hybrid CM. This helps to prevent CMs from receiving duplicate traffic.

## Static TLV Forwarding

As per DOCSIS 3.0 specifications, the Cisco CMTS must support Static Multicast. When the CM tries to register with the Cisco CMTS, the Cisco CMTS checks whether Static Multicast Encoding is present in the CM configuration file. If the Static Multicast Encoding is present, the Cisco CMTS sends a DSID corresponding to each Static Multicast channel in the Registration-Response (REG-RSP) message.

The Multicast DSID management is located at Supervisor and the interface card has to contact the Supervisor for proper DSID assignment. The interface card also caches the response from Supervisor to eliminate the need to communicate to the Supervisor for subsequent Static Multicast encoding.

## Explicit Tracking

The Cisco CMTS can perform explicit tracking with IGMPv3 support. The IGMPv3 removes the report suppression feature associated with the IGMPv2 specification enabling the Cisco CMTS to get the complete information on session and host information. This benefits the IGMP Fast Leave processing and DSID management for each CM.

A host or session database is used to track hosts (IP/MAC) joining a particular multicast session. From the host, you can track the CM based on the SID and cable downstream interface. This database also helps to determine whether the Cisco CMTS should remove the DSID from a particular CM when the multicast session is over.

## Multicast Quality of Service Enhancement

DOCSIS 3.0 mandates that the CMTS should not admit any flow exceeding the session limit. Though the current Multicast QoS (MQoS) session limit admits the session, it fails to provide any QoS for sessions exceeding the session limit.



---

**Note** Multicast packets are sent using the default Group Service Flows (GSF) when the Multicast QoS feature is disabled.

---

As part of DOCSIS 3.0 requirements for Multicast QoS, Group Classifier Rules (GCR) is supported. The Cisco CMTS determines the set of Group Configurations (GCs) whose session range matches the multicast group address. For SSM, the source address is also used to identify the matching GCs. A GCR is created for each matching GC and linked to the multicast session. The GCR is assigned also with a unique identifier, SAID, and Group Service Flow (GSF).

The following conditions are used to select the GC entries:

- The GC entry with the highest rule priority is selected, if more than one GC entry matches.
- All matching GC entries are selected, when multiple GCs have the same highest rule priority.

The GCR classification is done based on type of service (TOS) fields. The TOS specifier in the GCR is used to choose the correct GCR when multiple GCRs match a single multicast session.



---

**Note** When two multicast group configurations (GCs) have the same session range and configuration (under global or bundle configuration), then the same forwarding interface selection is not guaranteed.

---

Non-IP multicasts and broadcast packets use GSF. They are similar to individual service flows and are shared by all the CMs on a particular Digital Command Signal (DCS) matching the same GCR. A single GSF is used for multicast sessions matching different GCs using the same aggregate GQC.

## Multicast Secondary Bonding Group

The DOCSIS 3.0-compliant CM can receive multicast packets from non-primary (or bonded) channels using the MDF support at the CMTS.

The multicast secondary bonding group is defined as a shared bonding group or RF channel that feeds more than one fiber node through an optical split. This allows CMs from different primary bonding groups and channels to listen to one or more shared sets. The multicast packets are replicated only to the shared downstream channel set, which helps conserve the downstream bandwidth.

DOCSIS 3.0 defines attribute-based service flow creation, which allows the Cisco CMTS to make more “intelligent” decisions on the selection of bonding group or individual channel for unicast and multicast forwarding.

The Multicast Secondary Bonding Group provides the following benefits:

- New MQoS and attribute-based forwarding for Multicast Secondary Bonding Group.
- The primary downstream interface acts as a forwarding interface for narrowband CMs.
- The following algorithm is used to select a forwarding interface for wideband CMs:
  - A primary bonding group is selected if a group-config matching the session is present in it. MQoS parameters are taken from the group-config.
  - A primary bonding group is selected if a group-config is not present at the bundle level or at the global level.
  - A group-config found at the bundle level or global level is used to find the Group-QoS-Config (GQC) and eventually the attribute and forbidden bit-masks, which are then used to find the interface.
  - All Wideband Cable Modems (WCMs) in a bundle use the same secondary bonding group if a bundle-level group-config or global-level group-config is configured.
- The IGMP report ignores a source if the given source address fails to find a matching interface.
  - If a matching interface is found, that interface is used for forwarding and the MQoS parameters are taken from the matching group-config from the forwarding interface or bundle interface or global level.
  - If a matching interface is not found, then the IGMP report is ignored.
- For a static join, attribute-based forwarding is not supported, and only the primary downstream is used.

## Load Balancing

The Load Balancing feature does not load balance a CM while a multicast stream is going on for that particular CM. It utilizes the Explicit Tracking Database, which holds complete information on the CM subscription to achieve this.

## Multicast DSID Forwarding Disabled Mode

For any application that needs the cable modem to perform IGMP snooping, the MDF on the cable modem must be disabled. Cable modems registered in MDF-enabled mode by the Cisco CMTS do not perform IGMP



snooping because MDF forwarding is based on DSID filtering. The **cable multicast mdf-disable** command disables the MDF capability on the cable modem.

This command is configured on the route processor and is downloaded to the cable line card via the configuration update. The configuration does not change the Cisco CMTS forwarding mechanism or DSID allocation. The Cisco CMTS allocates the DSID and the multicast packet is encapsulated with the DSID header. This does not affect traffic forwarding on the MDF-disabled cable modem. According to DOCSIS3.0 specification, pre-DOCSIS2.0 or MDF-disabled cable modems ignore the DSID header and continue multicast forwarding based on the Group Media Access Control (GMAC) from IGMP snooping. When the cable modem runs in MDF-disabled mode, only IGMPv2 is supported and the Cisco CMTS drops IGMPv3 and MLD messages.

Multicast encryption based on BPI+ is not supported on non-MDF cable modems, if IGMP SSM mapping is used. A non-MDF cable modem is either a pre-DOCSIS 3.0 cable modem or a DOCSIS 3.0 cable modem running in MDF-disabled mode.

## MDF1 Support for DOCSIS 2.0 Hybrid Cable Modems

The Cisco CMTS router enables MDF capability for DOCSIS 2.0 hybrid cable modems, IPv6, and other cable modems that advertise MDF capability to allow IPv6 packet forwarding. The **wb-incapable-cm** keyword in the **cable multicast mdf-disable** command disables MDF on all DOCSIS 2.0 hybrid cable modems including DOCSIS Set-Top Gateway (DSG) hybrid embedded cable modems to support IGMP snooping.

## DSG Disablement for Hybrid STBs

The **cable multicast mdf-disable** command with the **wb-incapable-cm** keyword prevents all DOCSIS 2.0 DSG embedded cable modems from receiving DSG multicast traffic besides disabling MDF support.

The **wb-incapable-cm** keyword disables MDF capability only on non-DSG DOCSIS 2.0 hybrid cable modems. To disable MDF capability on all DSG embedded cable modems (DOCSIS 3.0 DSG and DOCSIS 2.0 DSG hybrid), a new keyword, DSG, is introduced.



---

**Note** After disabling MDF capability, you must run **clear cable modem reset** command to bring all DSG embedded cable modems online.

---

## Benefits of MDF1 Support

- Supports IPv6 on different known cable modem firmware types.
- Disables the MDF capability on the Cisco CMTS.
- Supports In-Service Software Upgrade (ISSU) and line card high availability.

## Dynamic Multicast Replication Sessions

When users enable IPTV service on the Cisco cBR routers, to enhance the performance, the following features are supported on Cisco cBR.

- Supports 8000 SIDs per bundle interface:

The Cisco cBR supports 8000 SIDs per bundle, because each MQoS need one SID for each multicast session.

- Provides faster and efficient IP Communicator messages.
- Provides faster multicast forwarding.
- Enables caching of dynamic multicast sessions.

## Cache Multicast Replication Sessions

Creating a new multicast replication session takes most of the CPU cycles when compared to joining an existing multicast replication session. Most resources associated with a multicast replication session can be cached after the session ends.

Hence, when a new IGMP join request is received later, these resources can be reused.

The multicast session replication cache is available only on an active SUP. When SUPSO happens, all cached sessions are lost, and are then recreated on the new active SUP when an IGMP/MLD join request is received.

When LCSO happens, all cache sessions of this LC are cleared and are recreated on the new active LC when an IGMP/MLD join request is received.

## How to Configure the DOCSIS 3.0 Multicast Support

This section describes the following tasks that are required to implement DOCSIS 3.0 Multicast Support on Cisco CMTS Routers:

### Configuring Basic Multicast Forwarding

To configure a basic multicast forwarding profile that can be applied to a DOCSIS 3.0 multicast configuration, use the **ip multicast-routing** command. You must configure a multicast routing profile before you can proceed with a multicast group.

#### Procedure

|               | Command or Action                                                                                | Purpose                                                                                                            |
|---------------|--------------------------------------------------------------------------------------------------|--------------------------------------------------------------------------------------------------------------------|
| <b>Step 1</b> | <b>enable</b><br><b>Example:</b><br>Router> enable                                               | Enables privileged EXEC mode. <ul style="list-style-type: none"> <li>• Enter your password if prompted.</li> </ul> |
| <b>Step 2</b> | <b>configure terminal</b><br><b>Example:</b><br>Router# configure terminal                       | Enters global configuration mode.                                                                                  |
| <b>Step 3</b> | <b>IP multicast-routing [vrf]</b><br><b>Example:</b><br>Router(config)# IP multicast-routing vrf | Enables multicast routing globally or on a particular virtual routing and forwarding (VRF) interface.              |

|        | Command or Action                                                                                                                                         | Purpose                                                                                                                                                                                                                                                                                                 |
|--------|-----------------------------------------------------------------------------------------------------------------------------------------------------------|---------------------------------------------------------------------------------------------------------------------------------------------------------------------------------------------------------------------------------------------------------------------------------------------------------|
| Step 4 | <b>interface bundle</b> <i>number</i><br><b>Example:</b><br><pre>Router(config)# interface bundle 1</pre>                                                 | Configures the interface bundle and enters interface configuration mode.                                                                                                                                                                                                                                |
| Step 5 | <b>IP pim sparse-mode</b><br><b>Example:</b><br><pre>Router(config-if)# IP pim sparse-mode</pre>                                                          | Configures sparse mode of operation.<br><b>Note</b> The Cisco CMTS router must have a Protocol Independent Multicast (PIM) rendezvous point (RP) configured for the PIM sparse mode. The Supervisor is configured using the <b>ip pim rp-address</b> command or Auto-Supervisor configuration protocol. |
| Step 6 | <b>IP pim sparse-dense-mode</b><br><b>Example:</b><br><pre>Router(config-if)# IP pim sparse-dense-mode</pre>                                              | Configures the interface for either sparse mode or dense mode of operation, depending on the mode in which the multicast group is operating.                                                                                                                                                            |
| Step 7 | <b>IP igmp version version-number</b><br><b>Example:</b><br><pre>Router(config-if)# IP igmp version 3</pre>                                               | Configures the interface to use IGMP version 3.                                                                                                                                                                                                                                                         |
| Step 8 | <b>IP igmp v3-query-max-response-time</b> <i>response_time</i><br><b>Example:</b><br><pre>Router(config-if)# IP igmp v3-query-max-response-time 500</pre> | Configures the maximum query response time for igmp version 3.                                                                                                                                                                                                                                          |

## Configuring Querier's Robustness Variable

Table 231: Feature History

| Feature Name                                                             | Release Information            | Feature Description                                                                                                                                                                                                          |
|--------------------------------------------------------------------------|--------------------------------|------------------------------------------------------------------------------------------------------------------------------------------------------------------------------------------------------------------------------|
| Ability to configure Querier's Robustness Variable value in IGMP queries | Cisco IOS XE Bengaluru 17.6.1a | This feature fine-tunes the IGMP robustness variable to allow for expected packet loss on a subnet. You can increase the robustness variable on a congested network to increase the number of times that packets are resent. |

You can configure a robustness value to compensate for packet loss on a congested network. The robustness value is used by the IGMP software to determine the number of times to send messages.

The following example shows how to configure robustness value:

```
Router(config-if)# ip igmp robustness-variable 1
[Bundle1] Warning: robustness variable of 1 is advised only for reliable
```

```
links. Please be aware of the other IGMP parameters that may be affected by this
configuration change.
Router (config-if)#end
```

## Configuring Querier Robustness Variable

*Table 232: Feature History*

| Feature Name                                                                | Release Information         | Feature Description                                                                                                                                                                                                                                                                           |
|-----------------------------------------------------------------------------|-----------------------------|-----------------------------------------------------------------------------------------------------------------------------------------------------------------------------------------------------------------------------------------------------------------------------------------------|
| Ability to configure IPv6 Querier Robustness Variable value in MLD queries. | Cisco IOS XE Dublin 17.12.1 | This feature fine-tunes the MLD robustness variable, and specifies the retransmission count of MLD packets to minimize the impact of packet loss on a subnet.<br><br>You can increase the robustness variable on a congested network to increase the number of times that packets are resent. |

You can configure a robustness value to compensate for packet loss on a congested network. The robustness value is used by the Multicast Listener Discovery (MLD) software to determine the number of times to send messages.

MLD is a component of the Internet Protocol (IPv6) suite that is used by IPv6 routers for discovering multicast listeners on a directly attached link. The number of retransmissions depends on the Robustness Variable. This variable allows tuning the protocol according to the expected packet loss on a link. If a link is expected to be lossy the value of the Robustness Variable may be increased. MLD is robust to [Robustness Variable]-1 packet losses.

The following example shows how to configure robustness-variable value on an interface:

```
Router(config-if)#ipv6 mld robustness-variable 7
```

## Configuring Multicast DSID Forwarding

The multicast DSID forwarding is enabled by default. You cannot configure this feature.

## Configuring Explicit Tracking

The Explicit Tracking feature is enabled by default. You cannot configure it.

## Configuring Multicast QoS

To configure a Multicast QoS profile that can be applied to a DOCSIS 3.0 configuration, use the **cable multicast group-qos** command. You must configure a Multicast QoS profile before you can add a Multicast QoS profile to a QoS multicast group.

## Procedure

|               | Command or Action                                                                                                                                                                              | Purpose                                                                                                                                    |
|---------------|------------------------------------------------------------------------------------------------------------------------------------------------------------------------------------------------|--------------------------------------------------------------------------------------------------------------------------------------------|
| <b>Step 1</b> | <b>enable</b><br><b>Example:</b><br><pre>Router&gt; enable</pre>                                                                                                                               | Enables privileged EXEC mode. <ul style="list-style-type: none"> <li>• Enter your password if prompted.</li> </ul>                         |
| <b>Step 2</b> | <b>configureterminal</b><br><b>Example:</b><br><pre>Router# configure terminal</pre>                                                                                                           | Enters global configuration mode.                                                                                                          |
| <b>Step 3</b> | <b>cable service class <i>class-index</i> name <i>service-class-name</i></b><br><b>Example:</b><br><pre>Router(config)# cable service class 1 name MQOS_DEFAULT</pre>                          | Configures the name of the cable service class.                                                                                            |
| <b>Step 4</b> | <b>cable service class <i>class-index</i> downstream</b><br><b>Example:</b><br><pre>Router(config)# cable service class 1 downstream</pre>                                                     | Configures the downstream for the cable service class.                                                                                     |
| <b>Step 5</b> | <b>cable service class <i>class-index</i> max-rate <i>maximum-bandwidth-allowed</i></b><br><b>Example:</b><br><pre>Router(config)# cable service class 1 max-rate 10000000</pre>               | Configures the maximum allowed bandwidth for the cable service class.                                                                      |
| <b>Step 6</b> | <b>cable service class <i>class-index</i> min-rate <i>cir</i></b><br><b>Example:</b><br><pre>Router(config)# cable service class 1 min-rate 1000000</pre>                                      | Configures the minimum committed information rate for the cable service class.                                                             |
| <b>Step 7</b> | <b>cable multicast group-qos default scn <i>service-class-name</i> aggregate</b><br><b>Example:</b><br><pre>Router(config)# cable multicast group-qos default scn MQOS_DEFAULT aggregate</pre> | Specifies the default service class name for the QoS profile.                                                                              |
| <b>Step 8</b> | <b>cable multicast qos group <i>number</i> priority <i>value</i></b><br><b>Example:</b><br><pre>Router(config)# cable multicast qos group 20 priority 1</pre>                                  | Configures a multicast QoS group and enters multicast QoS configuration mode, and specifies the priority of the cable multicast QoS group. |

|                | Command or Action                                                                                                                                                             | Purpose                                                                                                                                                      |
|----------------|-------------------------------------------------------------------------------------------------------------------------------------------------------------------------------|--------------------------------------------------------------------------------------------------------------------------------------------------------------|
| <b>Step 9</b>  | <b>application-id</b> <i>app-id</i><br><b>Example:</b><br>Router(config-mqos)# <b>application-id</b> 10                                                                       | Specifies the application identification number of the multicast QoS group. This value is configured to enable admission control to the multicast QoS group. |
| <b>Step 10</b> | <b>session-range ip-address ip-mask</b><br><b>Example:</b><br>Router(config-mqos)# <b>session-range</b> 230.0.0.0<br>255.0.0.0                                                | Specifies the session range IP address and IP mask of the multicast QoS group. You can configure multiple session ranges.                                    |
| <b>Step 11</b> | <b>cable multicast qos group number priority value [global]</b><br><b>Example:</b><br>Router(config)# <b>cable multicast qos group</b> 20<br><b>priority</b> 63 <b>global</b> | Specifies the multicast QoS group identifier.                                                                                                                |

## Selecting a Forwarding Interface Based on Service Flow Attribute

The Service Flow Attribute feature allows a bonded CM to listen to multiple bonding groups, and using the interface-specific bit-masks, the CM can select the best route to receive multicast traffic.

The Service Flow Attribute feature allows selection of a forwarding interface based on the DOCSIS 3.0 construct named “service flow attribute mask.” Every interface has an attribute bit-mask depicting attributes of that interface. The multicast service class specified in the group QoS configuration contains required and forbidden attribute bit-masks. If a bonded CM can listen to multiple bonding groups (wideband interfaces), using specific bit-masks in the service class as well as on the bonding group, then one of these bonding groups can be selected for forwarding of multicast traffic.

### Procedure

|               | Command or Action                                                                                                                                  | Purpose                                                                                                            |
|---------------|----------------------------------------------------------------------------------------------------------------------------------------------------|--------------------------------------------------------------------------------------------------------------------|
| <b>Step 1</b> | <b>enable</b><br><b>Example:</b><br>Router> enable                                                                                                 | Enables privileged EXEC mode. <ul style="list-style-type: none"> <li>• Enter your password if prompted.</li> </ul> |
| <b>Step 2</b> | <b>configure terminal</b><br><b>Example:</b><br>Router# configure terminal                                                                         | Enters global configuration mode.                                                                                  |
| <b>Step 3</b> | <b>cable service class class-index name name</b><br><b>Example:</b><br>Router(config)# <b>cable service class</b> 10 <b>name</b><br><b>mcast10</b> | Configures the service class name.                                                                                 |

|         | Command or Action                                                                                                                                                                                           | Purpose                                                                                       |
|---------|-------------------------------------------------------------------------------------------------------------------------------------------------------------------------------------------------------------|-----------------------------------------------------------------------------------------------|
| Step 4  | <p><b>cable service class</b> <i>class-index</i> <b>downstream</b></p> <p><b>Example:</b></p> <pre>Router(config)# cable service class 10 downstream</pre>                                                  | Configures the downstream for the selected service class.                                     |
| Step 5  | <p><b>cable service class</b> <i>class-index</i> <b>max-rate</b> <i>maximum-rate</i></p> <p><b>Example:</b></p> <pre>Router(config)# cable service class 10 max-rate 1000000</pre>                          | Configures the maximum rate for the selected service class.                                   |
| Step 6  | <p><b>cable service class</b> <i>class-index</i> <b>min-rate</b> <i>minimum-rate</i></p> <p><b>Example:</b></p> <pre>Router(config)# cable service class 10 min-rate 100000</pre>                           | Configures the minimum rate for the selected service class.                                   |
| Step 7  | <p><b>cable service class</b> <i>class-index</i> <b>req-attr-mask</b> <i>required-attribute-mask</i></p> <p><b>Example:</b></p> <pre>Router(config)# cable service class 10 req-attr-mask 8000000F</pre>    | Configures the required attribute mask for the selected service class.                        |
| Step 8  | <p><b>cable service class</b> <i>class-index</i> <b>forb-attr-mask</b> <i>forbidden-attribute-mask</i></p> <p><b>Example:</b></p> <pre>Router(config)# cable service class 10 forb-attr-mask 7FFFFFF0</pre> | Configures the forbidden attribute mask for the selected service class name.                  |
| Step 9  | <p><b>cable multicast group-qos</b> <i>number scn service-class-name</i> <b>aggregate</b></p> <p><b>Example:</b></p> <pre>Router(config)# cable multicast group-qos 1 scn 10 mcast10 aggregate</pre>        | Configures the cable multicast group QoS identifier, service class name, and multicast value. |
| Step 10 | <p><b>cable multicast qos group</b> <i>group</i> <b>priority</b> <i>priority</i></p> <p><b>Example:</b></p> <pre>Router(config)# cable multicast qos group 1 priority 1</pre>                               | Configures the cable MQoS group and enters MQoS configuration mode.                           |
| Step 11 | <p><b>session-range</b> <i>session-range mask</i></p> <p><b>Example:</b></p>                                                                                                                                | Specifies session range.                                                                      |

|                | Command or Action                                                                                                                                                                                                                                                                                                                                                                                                                                                                                                                                                                                                                                                                                                                                             | Purpose                                                                                                                   |
|----------------|---------------------------------------------------------------------------------------------------------------------------------------------------------------------------------------------------------------------------------------------------------------------------------------------------------------------------------------------------------------------------------------------------------------------------------------------------------------------------------------------------------------------------------------------------------------------------------------------------------------------------------------------------------------------------------------------------------------------------------------------------------------|---------------------------------------------------------------------------------------------------------------------------|
|                | Router (config-mqos) # <b>session-range</b> 230.1.1.1<br>255.255.255.255                                                                                                                                                                                                                                                                                                                                                                                                                                                                                                                                                                                                                                                                                      |                                                                                                                           |
| <b>Step 12</b> | <b>group-qos</b> <i>qos</i><br><b>Example:</b><br>Router (config-mqos) # <b>group-qos</b> 1                                                                                                                                                                                                                                                                                                                                                                                                                                                                                                                                                                                                                                                                   | Specifies the group QoS.                                                                                                  |
| <b>Step 13</b> | <b>exit</b><br><b>Example:</b><br>Router (config-mqos) # <b>exit</b>                                                                                                                                                                                                                                                                                                                                                                                                                                                                                                                                                                                                                                                                                          | Returns to global configuration mode.                                                                                     |
| <b>Step 14</b> | <b>interface bundle</b> <i>number</i><br><ul style="list-style-type: none"> <li>• <b>ip address</b> <i>ip mask</i></li> <li>• <b>ip pim sparse-mode</b></li> <li>• <b>ip helper-address</b> <i>helper-address</i></li> <li>• <b>cable multicast-qos group</b> <i>group</i></li> </ul> <b>Example:</b><br>Router (config) # <b>interface</b> Bundle1<br>Router (config-if) # <b>ip address</b> 40.1.1.1<br>255.255.255.0<br>Router (config-if) # <b>ip pim sparse-mode</b><br>Router (config-if) # <b>ip helper-address</b> 2.39.16.1<br>Router (config-if) # <b>cable multicast-qos group</b> 1                                                                                                                                                               | Configures the interface bundle with the IP address, helper address, and MQoS group.                                      |
| <b>Step 15</b> | <b>exit</b><br><b>Example:</b><br>Router (config-if) # <b>exit</b>                                                                                                                                                                                                                                                                                                                                                                                                                                                                                                                                                                                                                                                                                            | Returns to global configuration mode.                                                                                     |
| <b>Step 16</b> | <b>interface wideband-cable</b><br><i>slot/subslot/port:wideband-channel</i><br><ul style="list-style-type: none"> <li>• <b>description</b> <i>description</i></li> <li>• <b>cable bundle</b> <i>number</i></li> <li>• <b>cable rf-channel channel-list</b> <i>grouplist</i><br/><b>bandwidth-percent</b> <i>bw-percent</i></li> <li>• <b>cable downstream attribute-mask</b> <i>attribute-mask</i></li> </ul> <b>Example:</b><br>Router (config) # <b>interface</b> Wideband-Cable1/0/0:0<br>Router (config-if) # <b>description</b> cable rf-channels<br><b>channel-list</b> 0-7 <b>bandwidth-percent</b> 20<br>Router (config-if) # <b>cable bundle</b> 1<br>Router (config-if) # <b>cable rf-channels channel-list</b><br>0-7 <b>bandwidth-percent</b> 20 | Selects the interface for forwarding based on the bit-masks specified in the service class and on the wideband interface. |



|                | Command or Action                                                            | Purpose                          |
|----------------|------------------------------------------------------------------------------|----------------------------------|
|                | <code>Router(config-if)# cable downstream attribute-mask 8000000F</code>     |                                  |
| <b>Step 17</b> | <b>end</b><br><br><b>Example:</b><br><br><code>Router(config-if)# end</code> | Returns to privileged EXEC mode. |

## Configuring Multicast DSID Forwarding Disabled Mode

To disable MDF on the cable modem, use the **cable multicast mdf-disable** command in global configuration mode.



**Note** Multicast encryption based on BPI+ is not supported on non-MDF cable modems, if IGMP SSM mapping is used.

### Procedure

|               | Command or Action                                                                                                                           | Purpose                                                                                                            |
|---------------|---------------------------------------------------------------------------------------------------------------------------------------------|--------------------------------------------------------------------------------------------------------------------|
| <b>Step 1</b> | <b>enable</b><br><br><b>Example:</b><br><br><code>Router&gt; enable</code>                                                                  | Enables privileged EXEC mode. <ul style="list-style-type: none"> <li>• Enter your password if prompted.</li> </ul> |
| <b>Step 2</b> | <b>configure terminal</b><br><br><b>Example:</b><br><br><code>Router# configure terminal</code>                                             | Enters global configuration mode.                                                                                  |
| <b>Step 3</b> | <b>cable multicast mdf-disable [wb-incapable-cm]</b><br><br><b>Example:</b><br><br><code>Router(config)# cable multicast mdf-disable</code> | Disables MDF capability on the cable modem.                                                                        |
| <b>Step 4</b> | <b>exit</b><br><br><b>Example:</b><br><br><code>Router(config)# exit</code><br><code>Router#</code>                                         | Exits the global configuration mode.                                                                               |

## Configuring Multicast Replication Session Globally

Use the following command to configure the maximum number of multicast replication sessions globally and the value is configured per L2 forwarding interface.

If the operator does not configure a value for the maximum number, by default, is set to 0 for all L2 forwarding interfaces, and the cache function is not valid. Cisco cBR does not cache the multicast replication sessions.

If the value is changed from a number such as 10 to 0, all current caches is cleared. The value range is from 0 to 500.

The following example shows how to set the maximum number of cache to 0:

```
enable
configure terminal
cable multicast ses-cache 0
```

The following example shows how to change the current value:

```
enable
configure terminal
[no|default] cable multicast ses-cache <0-500>
```

## Configuring Multicast Replication Sessions on Forwarding Interface

Use the following command to enable the multicast replication session on each L2 forwarding interface.

The value range for the maximum number is 0 to 500. If the value is changed from a number such as 10 to 0, all current caches is cleared.

The configured value for the interface has higher priority than the system value. The following example shows how to configure session cache on forwarding interface and make Cisco cBR use the system values:

```
enable
configure terminal
interface wideband-Cable {slot /subslot /controller :wideband-channel}
[no|default] cable multicast ses-cache
```

The following example shows how to set the maximum number of cache for the interface:

```
enable
configure terminal
interface integrated-Cable {slot/subslot/port:rf-channel}
cable multicast ses-cache 500
```

The following example shows how to configure a value 0 for an interface:

```
enable
configure terminal
interface integrated-Cable {slot/subslot/port:rf-channel}
no cable multicast ses-cache
```

## Clearing Multicast Replication Cache

Use the following command to clear the multicast replication session for all or for a specific L2 forwarding interface. The system deletes all current cache entries for all L2 forwarding interfaces or for a specific L2 interface.

```
enable
clear cable multicast ses-cache [interface xxx | all | counter]
```

## How to Monitor the DOCSIS 3.0 Multicast Support

To monitor the DOCSIS 3.0 Multicast Support feature, use the following procedures:

### Verifying the Basic Multicast Forwarding

To verify the configuration parameters for basic multicast forwarding, use the **show ip mroute** command as shown in the following example:

```
Router# show ip mroute

IP Multicast Routing Table
Flags: D - Dense, S - Sparse, B - Bidir Group, s - SSM Group, C - Connected,
L - Local, P - Pruned, R - RP-bit set, F - Register flag,
      T - SPT-bit set, J - Join SPT, M - MSDP created entry, E - Extranet,
      X - Proxy Join Timer Running, A - Candidate for MSDP Advertisement,
      U - URD, I - Received Source Specific Host Report,
      Z - Multicast Tunnel, z - MDT-data group sender,
      Y - Joined MDT-data group, y - Sending to MDT-data group,
      V - RD & Vector, v - Vector
Outgoing interface flags: H - Hardware switched, A - Assert winner
Timers: Uptime/Expires
Interface state: Interface, Next-Hop or VCD, State/Mode

(*, 230.1.1.1), 00:00:03/00:02:55, RP 30.1.1.1, flags: S
  Incoming interface: Null, RPF nbr 0.0.0.0
  Outgoing interface list:
    Bundle1, Forward/Sparse, 00:00:03/00:02:55, H
(*, 224.0.1.40), 00:12:02/00:02:19, RP 30.1.1.1, flags: SJCL
  Incoming interface: Null, RPF nbr 0.0.0.0
  Outgoing interface list:
    Bundle1, Forward/Sparse, 00:12:02/00:02:19
```

To verify the multicast information for the specified virtual interface bundle, based on IGMPv3, use the **show cable bundle multicast** command as shown in the following example:

```
Router# show cable bundle 1 multicast

CableBundle Interface Source IP Multicast IP MAC Address
1 Bundle1.1 * 230.1.1.1 0100.5e00.0001
```

To verify the MAC forwarding table for the specified virtual interface bundle, based on IGMPv3, use the **show cable bundle forwarding** command as shown in the following example:

```
Router# show cable bundle 1 forwarding

MAC address Interface Flags Location link sublink
00c0.5e01.0203 Cable8/0/0 3 64E5BF60 0 64E5BE00
00c0.5e01.0203 Cable7/0/0 3 64E5BE00 0 0
00c0.5e01.0101 Cable8/0/0 3 64E5BEE0 0 64E5BE40
```

## Verifying the Multicast DSID Forwarding

To verify the entire DSID database content, use the **show cable multicast dsid** command as shown in the following example:

```
Router# show cable multicast dsid
Multicast Group : 230.1.2.3
  Source        : *
  IDB           : Bu2           Interface: Mo1/1/0:0   Dsid: 0x1F078
  StatIndex     : 2           SAID: DEFAULT
Multicast Group : 230.1.2.3
  Source        : *
  IDB           : Bu2           Interface: Mo1/1/0:0   Dsid: 0x1F078
  StatIndex     : 3           SAID: 8196
Multicast Group : 230.1.2.3
  Source        : *
  IDB           : Bu2           Interface: Mo1/1/0:0   Dsid: 0x1F078
```

**StatIndex : 4 SAID: 8197**

To verify the entire database content, use the **show cable multicast db** command as shown in the following example:

```
Router# show cable multicast db
```

```
interface : Bundle1
Session (S,G) : (*,230.1.1.1)
Fwd Intfc Sub Intfc Host Intfc CM Mac Hosts
Wi1/1/0:0 Bundle1 Ca5/0/0 0018.6852.8056 1
```

To verify the information for the registered and unregistered CMs, use the **show cable modem verbose** command as shown in the following example:

```
Router# show cable modem 0010.7bb3.fcd1 verbose
```

```
MAC Address : 00C0.7bb3.fcd1
IP Address : 10.20.113.2
Prim Sid : 1
QoS Profile Index : 6
Interface : C5/0/U5
sysDescr : Vendor ABC DOCSIS 2.0 Cable Modem
Upstream Power : 0 dBmV (SNR = 33.25 dBmV)
Downstream Power : 0 dBmV (SNR = ----- dBmV)
Timing Offset : 1624
Initial Timing Offset : 2812
Received Power : 0.25
MAC Version : DOC1.0
Qos Provisioned Mode : DOC1.0
Enable DOCSIS2.0 Mode : Y
Phy Operating Mode : atdma
Capabilities : {Frag=N, Concat=N, PHS=N, Priv=BPI}
Sid/Said Limit : {Max Us Sids=0, Max Ds Sids=0}
```

```

Optional Filtering Support : {802.1P=N, 802.1Q=N}
Transmit Equalizer Support : {Taps/Symbol= 0, Num of Taps= 0}
Number of CPE IPs : 0(Max CPEs = 1)
CFG Max-CPE : 1
Flaps : 373(Jun 1 13:11:01)
Errors : 0 CRCs, 0 HCSes
Stn Mtn Failures : 0 aborts, 3 exhausted
Total US Flows : 1(1 active)
Total DS Flows : 1(1 active)
Total US Data : 1452082 packets, 171344434 bytes
Total US Throughput : 0 bits/sec, 0 packets/sec
Total DS Data : 1452073 packets, 171343858 bytes
Total DS Throughput : 0 bits/sec, 0 packets/sec
Active Classifiers : 0 (Max = NO LIMIT)
DSA/DSX messages : reject all
Dynamic Secret : A3D1028F36EBD54FDCC2F74719664D3F
Spoof attempt : Dynamic secret check failed
Total Time Online : 16:16

```

## Verifying the Explicit Tracking Feature

To verify explicit tracking information, use the **show cable multicast db** command as shown in the following example:

```
Router# show cable multicast db
```

```

Interface : Bundle1
Session (S,G) : (*,230.1.1.1)
Fwd Intfc Sub Intfc Host Intfc CM Mac Hosts
Mo1/1/0:0 Bundle1 Ca5/0/0 0018.6852.8056 1

```

## Verifying the Multicast QoS Feature

To verify the cable MQoS details, use the **show cable multicast qos** commands as shown in the following example:

```

Router# show cable multicast qos ?
group-config Display Multicast Group Config information
group-encryption Display Multicast Group Encryption information
group-qos Display Multicast Group QOS information
Router# show cable multicast qos group-config
Multicast Group Config 1 : Priority 1
Group QOS - 1
Group Encryption - 1
Session Range - Group Prefix 230.0.0.0 Mask 255.0.0.0 Source Prefix 0.0.0.0 Mask 0.0.0.0
Router# show cable multicast qos group-encryption
Multicast Group Encryption 1 : Algorithm 56bit-des
Router# show cable multicast qos group-qos
Group QOS Index Service Class Control Igmp Limit Override
DEFAULT MQOS_DEFAULT Aggregate NO-LIMIT 1 MQOS Aggregate NO-LIMIT

```

To verify the DOCSIS service flows on a given cable interface, use the **show interface service-flow** command as shown in the following example:

```
Router# show interface cable 6/0 service-flow
```

```

Sfid Sid Mac Address QoS Param Index Type Dir Curr Active
BG/CH
Prov Adm Act State Time

```

```

4      8193  ffff.ffff.ffff  3      3      3  sec(S) DS    act    21h57m
5      8196  ffff.ffff.ffff  4      4      4  sec(S) DS    act    00:17

```

## Verifying the Service Flow Attributes

To verify the configuration of service flow attributes on the service class configuration, use the `show cable service-class verbose` command as shown in the following example:

```

Router# show cable service-class 10 verbose
Index:                               10
Name:                                 mcast10
Direction:                           Downstream
Traffic Priority:                      0
Maximum Sustained Rate:               1000000 bits/sec
Max Burst:                             3044 bytes
Minimum Reserved Rate:                1000000 bits/sec
Minimum Packet Size                   0 bytes
Admitted QoS Timeout                  200 seconds
Active QoS Timeout                    0 seconds
Required Attribute Mask                8000000F
Forbidden Attribute Mask                7FFFFFF0
Scheduling Type:                      Undefined
Max Latency:                          0 usecs
Parameter Presence Bitfield:          {0x3148, 0x0}

```

To verify the configuration of SF attributes on the Wideband interface configuration, use the `show running-config interface` command as shown in the following example:

```

Router# show running-config interface Wideband-Cable 1/0/0:2
interface Wideband-Cable1/0/0:2
 cable bundle 1
 cable bonding-group-id 3
 cable rf-channel 3
 cable downstream attribute-mask 8000000F
end

```

## Verifying the Multicast Group Classifiers

To verify the details of the Group Classifier Rule, use the `show interface wideband-cable multicast-grc` command as shown in the following example:

```

Router# show interface wideband-cable 1/1/0:0 multicast-grc
Group Classifier Rules on Wideband-Cable1/1/0:0:
Classifier_id  Group_id  Group_Qos_id  Sid  SFID  ref_count
7             1         1             8196  10    1
8             2         1             8197  11    1

```

## Troubleshooting Tips

Make sure that CM can listen to the RF-frequencies specified for the Wideband interfaced chosen for forwarding multicast traffic.

## Viewing Current Cache

Use this command to show the current multicast replication session per L2 forwarding interface.

- If you do not specify an interface, this command shows a summary of the current L2 forwarding interface. The summary includes the cache number.
- If you specify an interface, this command shows a summary of the interface. Add the verbose option for more detailed information of the cache.

```
Router#show cable multicast ses-cache global summary
```

```
Global Cache Config: 20
```

```
-----
Fwd          Cache      Cache      Cache      Cache
Intfc        Config    Used       Missed     Hitted
Wi7/0/0:1    10        4          4          12
-----
Total                               4          4          12
```

```
Router# show cable multicast ses-cache global
```

```
Fwd Intfc          Sub Intfc          Session (S,G)
Wi7/0/0:0          Bundle1            (30.30.30.30,227.0.0.20)
                   Bundle1            (30.30.30.30,227.0.0.22)

Wi7/0/0:1          Bundle1            (30.30.30.30,226.0.0.20)
                   Bundle1            (30.30.30.30,226.0.0.22)
                   Bundle1            (30.30.30.30,226.0.0.23)
                   Bundle1            (30.30.30.30,226.0.0.21)
```

```
Router#show cable multicast ses-cache interface wi7/0/0:1
```

```
Fwd Intfc          Sub Intfc          Session (S,G)
Wi7/0/0:1          Bundle1            (30.30.30.30,226.0.0.20)
                   Bundle1            (30.30.30.30,226.0.0.22)
                   Bundle1            (30.30.30.30,226.0.0.23)
                   Bundle1            (30.30.30.30,226.0.0.21)
```

```
Router# show cable multicast ses-cache interface wi7/0/0:1 summary
```

```
Global Cache Config: 20
```

```
-----
Fwd          Cache      Cache      Cache      Cache
Intfc        Config    Used       Missed     Hitted
Wi7/0/0:1    10        4          4          12
```

```
Router# show cable multicast ses-cache wi8/0/0:0 verbose
```

```
Multicast Group   : 232.10.0.8
Source            : 100.0.0.2
Act GCRs         : 1
Interface        : Bu255 State: A GI: Bu255 RC: 0
GCR              : GC   SAID   SFID   Key   GQC   GEn
                  10   8858  24    0    1    0
```

```

Multicast Group   : 232.10.0.16
      Source      : 100.0.0.2
      Act GCRs    : 1
      Interface   : Bu255  State: A  GI: Bu255  RC: 0
      GCR         : GC      SAID      SFID      Key      GQC      GEn
                   10      8859      25        0        1        0
Total session cache num: 2

```

For the **Cache Missed** value, the value is increased for a new join request when cached entry is not available for reusing.

## Configuration Examples for DOCSIS 3.0 Multicast Support

This section provides the following configuration examples:

### Example: Configuring Basic Multicast Forwarding



**Note** The commands given below are required to enable the Cisco CMTS to forward multicast packets. However, Multicast QoS, and Authorization features are all optional for multicast packets to be forwarded correctly.

In the following example, a basic multicast forwarding profile is configured.

```

ip multicast-routing
interface TenGigabitEthernet4/1/0
  ip pim sparse-dense-mode
interface Bundle 1
  ip pim sparse-mode
  ip igmp version 3

```

### Example: Configuring Multicast QoS



**Note** A default service class and GQC must be defined before proceeding with configuring Multicast QoS.

In the following example, Multicast QoS is configured. You should define three objects and templates and then associate these to a particular bundle or forwarding interface. The objects are Service-Class, Group-QoS-Config (GQC), and Group-Config.

```

cable service class 1 name MQOS_DEFAULT
cable service class 1 downstream
cable service class 1 max-rate 10000000
cable service class 1 min-rate 1000000

```



```

cable multicast group-qos default scn MQOS_DEFAULT aggregate
cable multicast group-qos 10 scn MQOS single
cable multicast qos group 20 priority 1
application-id 10
session-range 230.0.0.0 255.0.0.0
tos 1 6 15
vrf name1
cable multicast qos group 20 priority 63 global

```

## Example: Configuring Forwarding Interface Selection Based on Service Flow Attribute

In the following example, the service flow attribute-based Forwarding Interface Selection is configured. To send multicast traffic for group 230.1.1.1, interface W6/0/0:0 is selected. The multicast QoS parameters are taken from group qos 1 (effectively from service class “mcast10”).

```

cable service class 10 name mcast10
cable service class 10 downstream
cable service class 10 max-rate 1000000
cable service class 10 min-rate 1000000
cable service class 10 req-attr-mask 8000000F
cable service class 10 forb-attr-mask 7FFFFFF0
cable multicast group-qos 1 scn mcast10 aggregate
cable multicast qos group 1 priority 1
session-range 230.1.1.1 255.255.255.255
  group-qos 1
interface Bundle1
  ip address 40.1.1.1 255.255.255.0
  ip pim sparse-mode
  ip helper-address 2.39.16.1
  cable multicast-qos group 1
end
interface Wideband-Cable6/0/0:0
cable bundle 10
cable rf-channels channel-list 0-7 bandwidth-percent 20
cable downstream attribute-mask 8000000F
end

```

## Example: Configuring Multicast Replication Session

The following example shows how to enable the multicast replication session on each L2 forwarding interface.

```

enable
conf t
interface xxx

[no|default] cable multicast ses-cache
cable multicast ses-cache 3

```

## Additional References

The following sections provide references related to the DOCSIS 3.0 Multicast Support on the CMTS Routers.

**Related Documents**

| Related Topic                              | Document Title                                                                                                                                                                                           |
|--------------------------------------------|----------------------------------------------------------------------------------------------------------------------------------------------------------------------------------------------------------|
| CMTS cable commands                        | <a href="http://www.cisco.com/en/US/docs/ios/cable/command/reference/cbl_book.html">http://www.cisco.com/en/US/docs/ios/cable/command/reference/cbl_book.html</a> Cisco IOS CMTS Cable Command Reference |
| Multicast VPN and DOCSIS 3.0 Multicast QoS | <a href="#">Multicast VPN and DOCSIS 3.0 Multicast QoS Support</a>                                                                                                                                       |
| DOCSIS 3.0 QoS Support                     | <a href="#">DOCSIS WFQ Scheduler on the Cisco CMTS Routers</a>                                                                                                                                           |

**Standards**

| Standard                   | Title                                                             |
|----------------------------|-------------------------------------------------------------------|
| CM-SP-CMCIv3-I01-080320    | Cable Modem to Customer Premise Equipment Interface Specification |
| CM-SP-MULPIv3.0-I08-080522 | MAC and Upper Layer Protocols Interface Specification             |
| CM-SP-OSSIV3.0-I07-080522  | Operations Support System Interface Specification                 |
| CM-SP-PHYv3.0-I07-080522   | Physical Layer Specification                                      |
| CM-SP-SECv3.0-I08-080522   | Security Specification                                            |

**MIBs**

| MIB <sup>4</sup>                                                                                  | MIBs Link                                                                                                                                                                                                                   |
|---------------------------------------------------------------------------------------------------|-----------------------------------------------------------------------------------------------------------------------------------------------------------------------------------------------------------------------------|
| <ul style="list-style-type: none"> <li>• DOCS-MCAST-AUTH-MIB</li> <li>• DOCS-MCAST-MIB</li> </ul> | To locate and download MIBs for selected platforms, Cisco software releases, and feature sets, use Cisco MIB Locator found at the following URL:<br><a href="http://www.cisco.com/go/mibs">http://www.cisco.com/go/mibs</a> |

<sup>4</sup> Not all supported MIBs are listed.

**RFCs**

| RFC                                                                                                                         | Title |
|-----------------------------------------------------------------------------------------------------------------------------|-------|
| No new or modified RFCs are supported by this feature, and support for existing RFCs has not been modified by this feature. | —     |

**Technical Assistance**

| Description                                                                                                                                                                                                                                                                                                                                                                           | Link                                                                                                              |
|---------------------------------------------------------------------------------------------------------------------------------------------------------------------------------------------------------------------------------------------------------------------------------------------------------------------------------------------------------------------------------------|-------------------------------------------------------------------------------------------------------------------|
| The Cisco Support and Documentation website provides online resources to download documentation, software, and tools. Use these resources to install and configure the software and to troubleshoot and resolve technical issues with Cisco products and technologies. Access to most tools on the Cisco Support and Documentation website requires a Cisco.com user ID and password. | <a href="http://www.cisco.com/cisco/web/support/index.html">http://www.cisco.com/cisco/web/support/index.html</a> |

## Feature Information for DOCSIS 3.0 Multicast Support

Use Cisco Feature Navigator to find information about the platform support and software image support. Cisco Feature Navigator enables you to determine which software images support a specific software release, feature set, or platform. To access Cisco Feature Navigator, go to the <https://cfmg.cisco.com/> link. An account on the Cisco.com page is not required.



**Note** The following table lists the software release in which a given feature is introduced. Unless noted otherwise, subsequent releases of that software release train also support that feature.

**Table 233: Feature Information for DOCSIS 3.0 Multicast Support**

| Feature Name                           | Releases                 | Feature Information                                                                |
|----------------------------------------|--------------------------|------------------------------------------------------------------------------------|
| DOCSIS 3.0 Multicast Support           | Cisco IOS XE Fuji 16.7.1 | This feature was integrated into the Cisco cBR Series Converged Broadband Routers. |
| Dynamic Multicast Replication Sessions | Cisco IOS XE Fuji 16.7.1 | This feature was integrated into the Cisco cBR Series Converged Broadband Routers. |





## CHAPTER 67

# IPv6 Segment Routing on Cisco cBR

---

In Cisco Converged Broadband Router, IPv6 Segment Routing is available as a sub mode of IPv6 address configuration.

Your software release may not support all the features that are documented in this module. For the latest feature information and caveats, see the release notes for your platform and software release. The Feature Information Table at the end of this document provides information about the documented features and lists the releases in which each feature is supported.

Use Cisco Feature Navigator to find information about platform support and Cisco software image support. To access Cisco Feature Navigator, go to <http://tools.cisco.com/ITDIT/CFN/>. An account on <http://www.cisco.com/> is not required.

- [Hardware Compatibility Matrix for the Cisco cBR Series Routers, on page 1121](#)
- [Information about IPv6 Segment Routing, on page 1123](#)
- [How to Configure IPv6 Segment Routing, on page 1123](#)
- [Configuration Examples, on page 1125](#)
- [Feature Information for IPv6 Segment Routing, on page 1126](#)

## Hardware Compatibility Matrix for the Cisco cBR Series Routers



---

**Note** The hardware components that are introduced in a given Cisco IOS-XE Release are supported in all subsequent releases unless otherwise specified.

---

Table 234: Hardware Compatibility Matrix for the Cisco cBR Series Routers

| Cisco CMTS Platform                    | Processor Engine                                                                                                                                                                                  | Interface Cards                                                                                                                                                                                                                                                                                                                                                                                                                                                                                                                                                                                                                                                                                                                                                                                 |
|----------------------------------------|---------------------------------------------------------------------------------------------------------------------------------------------------------------------------------------------------|-------------------------------------------------------------------------------------------------------------------------------------------------------------------------------------------------------------------------------------------------------------------------------------------------------------------------------------------------------------------------------------------------------------------------------------------------------------------------------------------------------------------------------------------------------------------------------------------------------------------------------------------------------------------------------------------------------------------------------------------------------------------------------------------------|
| Cisco cBR-8 Converged Broadband Router | <p><b>Cisco IOS-XE Release 16.5.1 and Later Releases</b></p> <p>Cisco cBR-8 Supervisor:</p> <ul style="list-style-type: none"> <li>• PID—CBR-SUP-250G</li> <li>• PID—CBR-CCAP-SUP-160G</li> </ul> | <p><b>Cisco IOS-XE Release 16.5.1 and Later Releases</b></p> <p>Cisco cBR-8 CCAP Line Cards:</p> <ul style="list-style-type: none"> <li>• PID—CBR-LC-8D30-16U30</li> <li>• PID—CBR-LC-8D31-16U30</li> <li>• PID—CBR-RF-PIC</li> <li>• PID—CBR-RF-PROT-PIC</li> <li>• PID—CBR-CCAP-LC-40G</li> <li>• PID—CBR-CCAP-LC-40G-R</li> <li>• PID—CBR-CCAP-LC-G2-R</li> <li>• PID—CBR-SUP-8X10G-PIC</li> <li>• PID—CBR-2X100G-PIC</li> </ul> <p>Digital PICs:</p> <ul style="list-style-type: none"> <li>• PID—CBR-DPIC-8X10G</li> <li>• PID—CBR-DPIC-2X100G</li> </ul> <p>Cisco cBR-8 Downstream PHY Module:</p> <ul style="list-style-type: none"> <li>• PID—CBR-D31-DS-MOD</li> </ul> <p>Cisco cBR-8 Upstream PHY Modules:</p> <ul style="list-style-type: none"> <li>• PID—CBR-D31-US-MOD</li> </ul> |



**Note** Do not use DPICs (8X10G and 2x100G) to forward IP traffic, as it may cause buffer exhaustion, leading to line card reload.

The only allowed traffic on a DPIC interface is DEPI, UEPI, and GCP traffic from the Cisco cBR-8 router to Remote PHY devices. Other traffic such as DHCP, SSH, and UTSC should flow via another router, since DPICs cannot be used for normal routing.

# Information about IPv6 Segment Routing

IPv6 Segment Routing (SR) is an SDN technology supporting IPv6 forwarding. In SR, a source or edge router performs source routing of traffic and encodes it as a segment list in an IPv6 routing extension header. The network is not required to maintain a per-application or per-flow state.

Any IPv6 capable node in a network may forward IPv6 traffic with an SR extension header to the first segment in the segment list without supporting IPv6 Segment Routing (SRv6).

At the node that hosts the current segment in the segment list, SRv6 is configured to modify the destination address of the traffic containing the SR extension header and destined to that segment ID. As part of SRv6 final processing, the next segment ID in the SR extension header is written to the destination address of the packet and a lookup is performed to forward the traffic to the new destination address.

The forwarding and SRv6 end processing continues at nodes hosting the segment IDs in the SR extension header until the last segment in the list is removed and the traffic is delivered to its ultimate destination.

## Restriction for Configuring IPv6 Segment Routing

Configuring duplicate IPv6 addresses on the same interface is not allowed.

# How to Configure IPv6 Segment Routing

## Configuring IPv6 Segment Routing on cBR

To configure IPv6 segment routing, use the following procedure.

1. Enter segment-routing sub mode when configuring an IPv6 address on an interface.

```
enable
configure terminal
interface type [slot_#/]port_#
ipv6 address ipv6_address_prefix/prefix_length
ipv6 address ipv6_address_prefix/prefix_length segment-routing
```

2. Define a local prefix as an SID

```
ipv6-sr prefix-sid
exit
```

## Verifying IPv6 Segment Routing Configuration

The following example shows how to verify SRv6 configuration:

```
Router#sh run
*Oct 17 13:13:23.975: %SYS-5-CONFIG_I: Configured from console by console
Router#sh run | sec Ether
interface Ethernet0/0
 no ip address
 shutdown
```

```
ipv6 address 2001::2001/64 segment-routing >>>>>>
ipv6-sr prefix-sid >>>>>>
```

## Configure Multiple IPv6 Addresses for Segment Routing

To configure multiple IPv6 addresses for SRv6 under the same interface, use the following commands.

1. Enter segment-routing sub mode when configuring an IPv6 address on an interface.

```
enable
configure terminal
interface type [slot_#/]port_#
ipv6 address ipv6_address_prefix/prefix_length segment-routing
```

2. Define a local prefix as an SID.

```
ipv6-sr prefix-sid
exit
```

## Verifying IPv6 Segment Routing Configuration on Multiple IPv6 Addresses

The following example shows how to verify SRv6 configuration for multiple IPv6 addresses:

```
Router#sh run | sec Ether
interface Ethernet0/0
no ip address
shutdown
ipv6 address 2001:db8:110::/64 segment-routing >>> submode 1
ipv6-sr prefix-sid
ipv6 address 2001:db9:111::/64 segment-routing >>> submode 2
ipv6-sr prefix-sid
interface Ethernet0/1
no ip address
shutdown
interface Ethernet0/2
no ip address
shutdown
interface Ethernet0/3
no ip address
shutdown
interface Ethernet1/0
no ip address
shutdown
interface Ethernet1/1
no ip address
shutdown
interface Ethernet1/2
```

## Disabling Prefix SID

To disable the local prefix SID associated to the segment ID, use the following commands.

```
enable
configure terminal
interface type [slot_#/]port_#
ipv6 address ipv6_address_prefix/prefix_length segment-routing
no ipv6-sr prefix-sid
end
```



## Verifying whether Prefix SID is Disabled

The following example shows how to verify whether the prefix SID is disabled:

```
Router#sh run | sec Ether
interface Ethernet0/0
  no ip address
  shutdown
  ipv6 address 110::110/64 segment-routing >>> "ipv6-sr prefix sid" is no longer present
  ipv6 address 111::111/64 segment-routing
  ipv6-sr prefix-sid
```

## Disabling SRv6 for a Prefix-SID

To disable SRv6 configuration for an IPv6 address and remove the IPv6 address, use the following command:

```
enable
configure terminal
interface type [slot_#/]port_#
no ipv6 address ipv6_address_prefix/prefix_length segment-routing
end
```

## Verifying whether SRv6 is Disabled and Prefix SID Removed

The following example shows how to verify whether SRv6 is disabled and the prefix SID is removed for the prefix SID.

```
Router#sh run |
*Oct 17 13:17:51.523: %SYS-5-CONFIG_I: Configured from console by console
Router#sh run | sec Ether
interface Ethernet0/0
  no ip address
  shutdown
  ipv6 address 110::110/64 segment-routing
  ipv6 address 111::111/64 segment-routing is entirely removed from ethernet0/0
```

## Configuration Examples

This section provides examples for IPv6 Segment Routing.

### Example: Configuring IPv6 Segment Routing on Cisco cBR

```
Router#conf terminal
Enter configuration commands, one per line. End with CNTL/Z.
Router(config)#inter Ether0/0
Router(config-if)#ipv6 address 110::110/64 ?
  anycast
  eui-64
  segment-routing
  <cr>
Router(config-if)#ipv6 address 110::110/64 segment-routing
Router(config-if-sr-ipv6)#?
ipv6 address segment-routing mode configuration commands:
  default  Set a command to its defaults
  exit     Exit from SR submode
  ipv6-sr  Request options specific to IPV6 segment-routing
  no      Negate a command or set its defaults
```

**Example: Configure Multiple IPv6 Addresses for SRv6**

```

Router(config-if-sr-ipv6)#ipv6-sr ?
  prefix-sid Set host prefix as IPv6 SR identifier prefix-sid
Router(config-if-sr-ipv6)#ipv6-sr prefix-sid
Router(config-if-sr-ipv6)#exit
Router(config-if)#exit
Router(config)#exit
Router#

```

**Example: Configure Multiple IPv6 Addresses for SRv6**

```

Router#conf terminal
Enter configuration commands, one per line. End with CNTL/Z.
Router(config)#inter Ether 0/0
Router(config-if)# ipv6 address 110::110/64 segment-routing
Router(config-if)# ipv6 address 111::111/64 segment-routing
Router(config-if-sr-ipv6)#ipv6-sr prefix-sid
Router(config-if-sr-ipv6)#end

```

**Example: Disabling Prefix SID**

```

Router#conf terminal
Enter configuration commands, one per line. End with CNTL/Z.
Router(config)#inter Ether0/0
Router(config-if)#inter Ether0/0
Router(config-if)#ipv6 address 110::110/64 segment-routing
Router(config-if-sr-ipv6)#no ipv6-sr prefix-sid
Router(config-if-sr-ipv6)#end

```

**Example: Disabling SR with an Active Prefix SID**

```

Router#conf terminal
Enter configuration commands, one per line. End with CNTL/Z.
Router(config)#inter Ether0/0
Router(config-if)#no ipv6 address 111::111/64 segment-routing
Router(config-if)#end

```

## Feature Information for IPv6 Segment Routing

Use Cisco Feature Navigator to find information about the platform support and software image support. Cisco Feature Navigator enables you to determine which software images support a specific software release, feature set, or platform. To access Cisco Feature Navigator, go to the <https://cfnng.cisco.com/> link. An account on the Cisco.com page is not required.



**Note** The following table lists the software release in which a given feature is introduced. Unless noted otherwise, subsequent releases of that software release train also support that feature.

**Table 235: Feature Information for IPv6 Segment Routing**

| Feature Name         | Releases                 | Feature Information                                                                                            |
|----------------------|--------------------------|----------------------------------------------------------------------------------------------------------------|
| IPv6 Segment Routing | Cisco IOS XE Fuji 16.7.1 | This feature was integrated into Cisco IOS XE Fuji 16.7.1 on the Cisco cBR Series Converged Broadband Routers. |



## PART **VIII**

### **IP Access Control Lists**

- [IP Access Control Lists, on page 1129](#)
- [Creating an IP Access List and Applying It to an Interface, on page 1141](#)
- [Creating an IP Access List to Filter IP Options, TCP Flags, Noncontiguous Ports, on page 1159](#)
- [Refining an IP Access List , on page 1181](#)
- [IP Named Access Control Lists, on page 1195](#)
- [IPv4 ACL Chaining Support , on page 1205](#)
- [IPv6 ACL Chaining with a Common ACL , on page 1211](#)
- [Commented IP Access List Entries, on page 1219](#)
- [Standard IP Access List Logging , on page 1225](#)
- [IP Access List Entry Sequence Numbering, on page 1231](#)
- [ACL IP Options Selective Drop , on page 1243](#)
- [ACL Syslog Correlation , on page 1249](#)
- [IPv6 Access Control Lists, on page 1263](#)
- [IPv6 Template ACL , on page 1273](#)
- [IPv6 ACL Extensions for Hop by Hop Filtering, on page 1279](#)





## CHAPTER 68

# IP Access Control Lists

---

Access control lists (ACLs) perform packet filtering to control which packets move through a network and to where. The packet filtering provides security by helping to limit the network traffic, restrict the access of users and devices to a network, and prevent the traffic from leaving a network. IP access lists reduce the chance of spoofing and denial-of-service attacks and allow dynamic, temporary user-access through a firewall.

IP access lists can also be used for purposes other than security, such as bandwidth control, restrict the content of routing updates, redistribute routes, trigger dial-on-demand (DDR) calls, limit debug output, and identify or classify traffic for quality of service (QoS) features. This module provides an overview of IP access lists.

Your software release may not support all the features that are documented in this module. For the latest feature information and caveats, see the release notes for your platform and software release. The Feature Information Table at the end of this document provides information about the documented features and lists the releases in which each feature is supported.

Use Cisco Feature Navigator to find information about platform support and Cisco software image support. To access Cisco Feature Navigator, go to <http://tools.cisco.com/ITDIT/CFN/>. An account on <http://www.cisco.com/> is not required.

### Contents

- [Hardware Compatibility Matrix for the Cisco cBR Series Routers, on page 1129](#)
- [Information About IP Access Lists, on page 1131](#)
- [Additional References, on page 1138](#)
- [Feature Information for IP Access Lists, on page 1139](#)

## Hardware Compatibility Matrix for the Cisco cBR Series Routers



---

**Note** The hardware components that are introduced in a given Cisco IOS-XE Release are supported in all subsequent releases unless otherwise specified.

---

Table 236: Hardware Compatibility Matrix for the Cisco cBR Series Routers

| Cisco CMTS Platform                    | Processor Engine                                                                                                                                                                                  | Interface Cards                                                                                                                                                                                                                                                                                                                                                                                                                                                                                                                                                                                                                                                                                                                                                                                 |
|----------------------------------------|---------------------------------------------------------------------------------------------------------------------------------------------------------------------------------------------------|-------------------------------------------------------------------------------------------------------------------------------------------------------------------------------------------------------------------------------------------------------------------------------------------------------------------------------------------------------------------------------------------------------------------------------------------------------------------------------------------------------------------------------------------------------------------------------------------------------------------------------------------------------------------------------------------------------------------------------------------------------------------------------------------------|
| Cisco cBR-8 Converged Broadband Router | <p><b>Cisco IOS-XE Release 16.5.1 and Later Releases</b></p> <p>Cisco cBR-8 Supervisor:</p> <ul style="list-style-type: none"> <li>• PID—CBR-SUP-250G</li> <li>• PID—CBR-CCAP-SUP-160G</li> </ul> | <p><b>Cisco IOS-XE Release 16.5.1 and Later Releases</b></p> <p>Cisco cBR-8 CCAP Line Cards:</p> <ul style="list-style-type: none"> <li>• PID—CBR-LC-8D30-16U30</li> <li>• PID—CBR-LC-8D31-16U30</li> <li>• PID—CBR-RF-PIC</li> <li>• PID—CBR-RF-PROT-PIC</li> <li>• PID—CBR-CCAP-LC-40G</li> <li>• PID—CBR-CCAP-LC-40G-R</li> <li>• PID—CBR-CCAP-LC-G2-R</li> <li>• PID—CBR-SUP-8X10G-PIC</li> <li>• PID—CBR-2X100G-PIC</li> </ul> <p>Digital PICs:</p> <ul style="list-style-type: none"> <li>• PID—CBR-DPIC-8X10G</li> <li>• PID—CBR-DPIC-2X100G</li> </ul> <p>Cisco cBR-8 Downstream PHY Module:</p> <ul style="list-style-type: none"> <li>• PID—CBR-D31-DS-MOD</li> </ul> <p>Cisco cBR-8 Upstream PHY Modules:</p> <ul style="list-style-type: none"> <li>• PID—CBR-D31-US-MOD</li> </ul> |



**Note** Do not use DPICs (8X10G and 2x100G) to forward IP traffic, as it may cause buffer exhaustion, leading to line card reload.

The only allowed traffic on a DPIC interface is DEPI, UEPI, and GCP traffic from the Cisco cBR-8 router to Remote PHY devices. Other traffic such as DHCP, SSH, and UTSC should flow via another router, since DPICs cannot be used for normal routing.

# Information About IP Access Lists

## Benefits of IP Access Lists

Access control lists (ACLs) perform packet filtering to control the flow of packets through a network. Packet filtering can restrict the access of users and devices to a network, providing a measure of security. Access lists can save network resources by reducing traffic. The benefits of using access lists are as follows:

- Authenticate incoming rsh and rcp requests—Access lists can simplify the identification of local users, remote hosts, and remote users in an authentication database that is configured to control access to a device. The authentication database enables Cisco software to receive incoming remote shell (rsh) and remote copy (rcp) protocol requests.
- Block unwanted traffic or users—Access lists can filter incoming or outgoing packets on an interface, thereby controlling access to a network based on source addresses, destination addresses, or user authentication. You can also use access lists to determine the types of traffic that are forwarded or blocked at device interfaces. For example, you can use access lists to permit e-mail traffic to be routed through a network and to block all Telnet traffic from entering the network.
- Control access to vty—Access lists on an inbound vty (Telnet) can control who can access the lines to a device. Access lists on an outbound vty can control the destinations that the lines from a device can reach.
- Identify or classify traffic for QoS features—Access lists provide congestion avoidance by setting the IP precedence for Weighted Random Early Detection (WRED) and committed access rate (CAR). Access lists also provide congestion management for class-based weighted fair queueing (CBWFQ), priority queueing, and custom queueing.
- Limit debug command output—Access lists can limit debug output based on an IP address or a protocol.
- Provide bandwidth control—Access lists on a slow link can prevent excess traffic on a network.
- Provide NAT control—Access lists can control which addresses are translated by Network Address Translation (NAT).
- Reduce the chance of DoS attacks—Access lists reduce the chance of denial-of-service (DoS) attacks. Specify IP source addresses to control traffic from hosts, networks, or users from accessing your network. Configure the TCP Intercept feature to can prevent servers from being flooded with requests for connection.
- Restrict the content of routing updates—Access lists can control routing updates that are sent, received, or redistributed in networks.
- Trigger dial-on-demand calls—Access lists can enforce dial and disconnect criteria.

## Border Routers and Firewall Routers Should Use Access Lists

There are many reasons to configure access lists; for example, you can use access lists to restrict contents of routing updates or to provide traffic flow control. One of the most important reasons to configure access lists is to provide a basic level of security for your network by controlling access to it. If you do not configure access lists on your router, all packets passing through the router could be allowed onto all parts of your network.

An access list can allow one host to access a part of your network and prevent another host from accessing the same area. In the figure below, by applying an appropriate access list to the interfaces of the router, Host A is allowed to access the Human Resources network and Host B is prevented from accessing the Human Resources network.

Access lists should be used in firewall routers, which are often positioned between your internal network and an external network such as the Internet. You can also use access lists on a router positioned between two parts of your network, to control traffic entering or exiting a specific part of your internal network.

To provide some security benefits of access lists, you should at least configure access lists on border routers--routers located at the edges of your networks. Such an access list provides a basic buffer from the outside network or from a less controlled area of your own network into a more sensitive area of your network. On these border routers, you should configure access lists for each network protocol configured on the router interfaces. You can configure access lists so that inbound traffic or outbound traffic or both are filtered on an interface.

Access lists are defined on a per-protocol basis. In other words, you should define access lists for every protocol enabled on an interface if you want to control traffic flow for that protocol.

## Definition of an Access List

Access control lists (ACLs) perform packet filtering to control the movement of packets through a network. Packet filtering provides security by limiting the access of traffic into a network, restricting user and device access to a network, and preventing traffic from leaving a network. IP access lists reduce the chance of spoofing and denial-of-service attacks, and allow dynamic, temporary user-access through a firewall.

IP access lists can also be used for purposes other than security, such as to control bandwidth, restrict the content of routing updates, redistribute routes, trigger dial-on-demand (DDR) calls, limit debug output, and identify or classify traffic for quality of service (QoS) features.

An access list is a sequential list that consists of at least one **permit** statement and possibly one or more **deny** statements. In the case of IP access lists, these statements can apply to IP addresses, upper-layer IP protocols, or other fields in IP packets.

Access lists are identified and referenced by a name or a number. Access lists act as packet filters, filtering packets based on the criteria defined in each access list.

After you configure an access list, for the access list to take effect, you must either apply the access list to an interface (by using the **ip access-group** command), a vty (by using the **access-class** command), or reference the access list by any command that accepts an access list. Multiple commands can reference the same access list.

In the following configuration, an IP access list named `branchoffices` is configured on Ten Gigabit Ethernet interface 4/1/0 and applied to incoming packets. Networks other than the ones specified by the source address and mask pair cannot access Ten Gigabit Ethernet interface 4/1/0. The destinations for packets coming from sources on network 172.16.7.0 are unrestricted. The destination for packets coming from sources on network 172.16.2.0 must be 172.31.5.4.

```
ip access-list extended branchoffices
 10 permit 172.16.7.0 0.0.0.3 any
 20 permit 172.16.2.0 0.0.0.255 host 172.31.5.4
!
interface tengigabitethernet 4/1/0
 ip access-group branchoffices in
```



## Access List Rules

The following rules apply to access lists:

- Only one access list per interface, per protocol, and per direction is allowed.
- An access list must contain at least one **permit** statement or all packets are denied entry into the network.
- The order in which access list conditions or match criteria are configured is important. While deciding whether to forward or block a packet, Cisco software tests the packet against each criteria statement in the order in which these statements are created. After a match is found, no more criteria statements are checked. The same **permit** or **deny** statements specified in a different order can result in a packet being passed under one circumstance and denied in another circumstance.
- If an access list is referenced by a name, but the access list does not exist, all packets pass. An interface or command with an empty access list applied to it permits all traffic into the network.
- Standard access lists and extended access lists cannot have the same name.
- Inbound access lists process packets before the packets are routed to an outbound interface. Inbound access lists that have filtering criteria that deny packet access to a network saves the overhead of routing lookup. Packets that are permitted access to a network based on the configured filtering criteria are processed for routing. For inbound access lists, when you configure a **permit** statement, packets are processed after they are received, and when you configure a **deny** statement, packets are discarded.
- Outbound access lists process packets before they leave the device. Incoming packets are routed to the outbound interface and then processed by the outbound access list. For outbound access lists, when you configure a **permit** statement, packets are sent to the output buffer, and when you configure a **deny** statement, packets are discarded.
- An access list can control traffic arriving at a device or leaving a device, but not traffic originating at a device.

## Helpful Hints for Creating IP Access Lists

The following tips will help you avoid unintended consequences and help you create more efficient, useful access lists.

- Create the access list before applying it to an interface (or elsewhere), because if you apply a nonexistent access list to an interface and then proceed to configure the access list, the first statement is put into effect, and the implicit **deny** statement that follows could cause you immediate access problems.
- Another reason to configure an access list before applying it is because an interface with an empty access list applied to it permits all traffic.
- All access lists need at least one **permit** statement; otherwise, all packets are denied and no traffic passes.
- Use the statement **permit any any** if you want to allow all other packets not already denied. Using the statement **permit any any** in effect avoids denying all other packets with the implicit deny statement at the end of an access list. Do not make your first access list entry **permit any any** because all traffic will get through; no packets will reach the subsequent testing. In fact, once you specify **permit any any**, all traffic not already denied will get through.
- Although all access lists end with an implicit **deny** statement, we recommend use of an explicit **deny** statement (for example, **deny ip any any**). On most platforms, you can display the count of packets

denied by issuing the **show access-list** command, thus finding out more information about who your access list is disallowing. Only packets denied by explicit **deny** statements are counted, which is why the explicit **deny** statement will yield more complete data for you.

- While you are creating an access list or after it is created, you might want to delete an entry.
  - You cannot delete an entry from a numbered access list; trying to do so will delete the entire access list. If you need to delete an entry, you need to delete the entire access list and start over.
  - You can delete an entry from a named access list. Use the **no permit** or **no deny** command to delete the appropriate entry.
- In order to make the purpose of individual statements more scannable and easily understood at a glance, you can write a helpful remark before or after any statement by using the **remark** command.
- If you want to deny access to a particular host or network and find out if someone from that network or host is attempting to gain access, include the **log** keyword with the corresponding **deny** statement so that the packets denied from that source are logged for you.
- This hint applies to the placement of your access list. When trying to save resources, remember that an inbound access list applies the filter conditions before the routing table lookup. An outbound access list applies the filter conditions after the routing table lookup.

## Named or Numbered Access Lists

All access lists must be identified by a name or a number. Named access lists are more convenient than numbered access lists because you can specify a meaningful name that is easier to remember and associate with a task. You can reorder statements in or add statements to a named access list.

Named access lists support the following features that are not supported by numbered access lists:

- IP options filtering
- Noncontiguous ports
- TCP flag filtering
- Deleting of entries with the **no permit** or **no deny** command



---

**Note** Not all commands that accept a numbered access list will accept a named access list. For example, vty uses only numbered access lists.

---

## Standard or Extended Access Lists

All access lists are either standard or extended access lists. If you only intend to filter on a source address, the simpler standard access list is sufficient. For filtering on anything other than a source address, an extended access list is necessary.

- Named access lists are specified as standard or extended based on the keyword **standard** or **extended** in the **ip access-list** command syntax.
- Numbered access lists are specified as standard or extended based on their number in the **access-list** command syntax. Standard IP access lists are numbered 1 to 99 or 1300 to 1999; extended IP access lists

are numbered 100 to 199 or 2000 to 2699. The range of standard IP access lists was initially only 1 to 99, and was subsequently expanded with the range 1300 to 1999 (the intervening numbers were assigned to other protocols). The extended access list range was similarly expanded.



---

**Note** Starting from Cisco IOS XE 16.9.4, use the **ip access-list** command to configure object-group based numbered ACL.

---

### Standard Access Lists

Standard IP access lists test only source addresses of packets (except for two exceptions). Because standard access lists test source addresses, they are very efficient at blocking traffic close to a destination. There are two exceptions when the address in a standard access list is not a source address:

- On outbound VTY access lists, when someone is trying to telnet, the address in the access list entry is used as a destination address rather than a source address.
- When filtering routes, you are filtering the network being advertised to you rather than a source address.

### Extended Access Lists

Extended access lists are good for blocking traffic anywhere. Extended access lists test source and destination addresses and other IP packet data, such as protocols, TCP or UDP port numbers, type of service (ToS), precedence, TCP flags, and IP options. Extended access lists can also provide capabilities that standard access lists cannot, such as the following:

- Filtering IP Options
- Filtering TCP flags
- Filtering noninitial fragments of packets (see the module “[Refining an IP Access List](#)”)



---

**Note** Packets that are subject to an extended access list will not be autonomous switched.

---

## IP Packet Fields You Can Filter to Control Access

You can use an extended access list to filter on any of the following fields in an IP packet. Source address and destination address are the two most frequently specified fields on which to base an access list:

- Source address--Specifies a source address to control packets coming from certain networking devices or hosts.
- Destination address--Specifies a destination address to control packets being sent to certain networking devices or hosts.
- Protocol--Specifies an IP protocol indicated by the keyword **eigrp**, **gre**, **icmp**, **igmp**, **ip**, **ipinip**, **nos**, **ospf**, **tcp**, or **udp**, or indicated by an integer in the range from 0 to 255 (representing an Internet protocol). If you specify a transport layer protocol (**icmp**, **igmp**, **tcp**, or **udp**), the command has a specific syntax.

- Ports and non-contiguous ports--Specifies TCP or UDP ports by a port name or port number. The port numbers can be noncontiguous port numbers. Port numbers can be useful to filter Telnet traffic or HTTP traffic, for example.
- TCP flags--Specifies that packets match any flag or all flags set in TCP packets. Filtering on specific TCP flags can help prevent false synchronization packets.
- IP options--Specifies IP options; one reason to filter on IP options is to prevent routers from being saturated with spurious packets containing them.

## Wildcard Mask for Addresses in an Access List

Address filtering uses wildcard masking to indicate to the software whether to check or ignore corresponding IP address bits when comparing the address bits in an access list entry to a packet being submitted to the access list. By carefully setting wildcard masks, you can specify one or more IP addresses for permit or deny tests.

Wildcard masking for IP address bits uses the number 1 and the number 0 to specify how the software treats the corresponding IP address bits. A wildcard mask is sometimes referred to as an inverted mask because a 1 and 0 mean the opposite of what they mean in a subnet (network) mask.

- A wildcard mask bit 0 means check the corresponding bit value; they must match.
- A wildcard mask bit 1 means ignore that corresponding bit value; they need not match.

If you do not supply a wildcard mask with a source or destination address in an access list statement, the software assumes an implicit wildcard mask of 0.0.0.0, meaning all values must match.

Unlike subnet masks, which require contiguous bits indicating network and subnet to be ones, wildcard masks allow noncontiguous bits in the mask.

The table below shows examples of IP addresses and masks from an access list, along with the corresponding addresses that are considered a match.

**Table 237: Sample IP Addresses, Wildcard Masks, and Match Results**

| Address       | Wildcard Mask                            | Match Results                                                            |
|---------------|------------------------------------------|--------------------------------------------------------------------------|
| 0.0.0.0       | 255.255.255.255                          | All addresses will match the access list conditions.                     |
| 172.18.0.0/16 | 0.0.255.255                              | Network 172.18.0.0                                                       |
| 172.18.5.2/16 | 0.0.0.0                                  | Only host 172.18.5.2 matches                                             |
| 172.18.8.0    | 0.0.0.7                                  | Only subnet 172.18.8.0/29 matches                                        |
| 172.18.8.8    | 0.0.0.7                                  | Only subnet 172.18.8.8/29 matches                                        |
| 172.18.8.15   | 0.0.0.3                                  | Only subnet 172.18.8.15/30 matches                                       |
| 10.1.2.0      | 0.0.252.255 (noncontiguous bits in mask) | Matches any even-numbered network in the range of 10.1.2.0 to 10.1.254.0 |

## Access List Sequence Numbers

The ability to apply sequence numbers to IP access list entries simplifies access list changes. Prior to the IP Access List Entry Sequence Numbering feature, there was no way to specify the position of an entry within an access list. If you wanted to insert an entry in the middle of an existing list, all of the entries after the desired position had to be removed, then the new entry was added, and then all the removed entries had to be reentered. This method was cumbersome and error prone.

This feature allows users to add sequence numbers to access list entries and resequence them. When you add a new entry, you specify the sequence number so that it is in a desired position in the access list. If necessary, entries currently in the access list can be resequenced to create room to insert the new entry.

## Access List Logging

The Cisco IOS software can provide logging messages about packets permitted or denied by a single standard or extended IP access list entry. That is, any packet that matches the entry will cause an informational logging message about the packet to be sent to the console. The level of messages logged to the console is controlled by the **logging console** global configuration command.

The first packet that triggers the access list entry causes an immediate logging message, and subsequent packets are collected over 5-minute intervals before they are displayed or logged. The logging message includes the access list number, whether the packet was permitted or denied, the source IP address of the packet, and the number of packets from that source permitted or denied in the prior 5-minute interval.

However, you can use the **ip access-list log-update** command to set the number of packets that, when match an access list (and are permitted or denied), cause the system to generate a log message. You might want to do this to receive log messages more frequently than at 5-minute intervals.



---

**Caution** If you set the *number-of-matches* argument to 1, a log message is sent right away, rather than caching it; every packet that matches an access list causes a log message. A setting of 1 is not recommended because the volume of log messages could overwhelm the system.

---

Even if you use the **ip access-list log-update** command, the 5-minute timer remains in effect, so each cache is emptied at the end of 5 minutes, regardless of the count of messages in each cache. Regardless of when the log message is sent, the cache is flushed and the count reset to 0 for that message the same way it is when a threshold is not specified.



---

**Note** The logging facility might drop some logging message packets if there are too many to be handled or if there is more than one logging message to be handled in 1 second. This behavior prevents the router from crashing due to too many logging packets. Therefore, the logging facility should not be used as a billing tool or an accurate source of the number of matches to an access list.

---

## Alternative to Access List Logging

Packets matching an entry in an ACL with a log option are process switched. It is not recommended to use the log option on ACLs, but rather use NetFlow export and match on a destination interface of Null0. This is done in the CEF path. The destination interface of Null0 is set for any packet that is dropped by the ACL.

## Additional IP Access List Features

Beyond the basic steps to create a standard or extended access list, you can enhance your access lists as mentioned below. Each of these methods is described completely in the module entitled “Refining an Access List.”

- You can impose dates and times when **permit** or **deny** statements in an extended access list are in effect, making your access list more granular and specific to an absolute or periodic time period.
- After you create a named access list, you might want to add entries or change the order of the entries, known as resequencing an access list.
- You can achieve finer granularity when filtering packets by filtering on noninitial fragments of packets.

## Where to Apply an Access List

You can apply access lists to the inbound or outbound interfaces of a device. Applying an access list to an inbound interface controls the traffic that enters the interface and applying an access list to an outbound interface controls the traffic that exits the interface.

When software receives a packet at the inbound interface, the software checks the packet against the statements that are configured for the access list. If the access list permits packets, the software processes the packet. Applying access lists to filter incoming packets can save device resources because filtered packets are discarded before entering the device.

Access lists on outbound interfaces filter packets that are transmitted (sent) out of the interface. You can use the TCP Access Control List (ACL) Splitting feature of the Rate-Based Satellite Control Protocol (RBSCP) on the outbound interface to control the type of packets that are subject to TCP acknowledgment (ACK) splitting on an outbound interface.

You can reference an access list by using a **debug** command to limit the amount of debug logs. For example, based on the filtering or matching criteria of the access list, debug logs can be limited to source or destination addresses or protocols.

You can use access lists to control routing updates, dial-on-demand (DDR), and quality of service (QoS) features.

## Additional References

### Related Documents

| Related Topic                                                                                                             | Document Title                                                                                            |
|---------------------------------------------------------------------------------------------------------------------------|-----------------------------------------------------------------------------------------------------------|
| IP access list commands: complete command syntax, command mode, command history, defaults, usage guidelines, and examples | <a href="#">Cisco IOS IP Addressing Services Command Reference</a>                                        |
| Filtering on source address, destination address, or protocol                                                             | <a href="#">Creating an IP Access List and Applying It to an Interface” module</a>                        |
| Filtering on IP Options, TCP flags, noncontiguous ports, or TTL                                                           | <a href="#">Creating an IP Access List to Filter IP Options, TCP Flags, or Noncontiguous Ports module</a> |

**Standards**

| Standards & RFCs | Title |
|------------------|-------|
| None             | —     |

**MIBs**

| MIB  | MIBs Link                                                                                                                                                                                                                              |
|------|----------------------------------------------------------------------------------------------------------------------------------------------------------------------------------------------------------------------------------------|
| None | To locate and download MIBs for selected platforms, Cisco IOS XE software releases, and feature sets, use Cisco MIB Locator found at the following URL:<br><br><a href="http://www.cisco.com/go/mibs">http://www.cisco.com/go/mibs</a> |

**Technical Assistance**

| Description                                                                                                                                                                                                                                                                                                                                                                           | Link                                                                                                              |
|---------------------------------------------------------------------------------------------------------------------------------------------------------------------------------------------------------------------------------------------------------------------------------------------------------------------------------------------------------------------------------------|-------------------------------------------------------------------------------------------------------------------|
| The Cisco Support and Documentation website provides online resources to download documentation, software, and tools. Use these resources to install and configure the software and to troubleshoot and resolve technical issues with Cisco products and technologies. Access to most tools on the Cisco Support and Documentation website requires a Cisco.com user ID and password. | <a href="http://www.cisco.com/cisco/web/support/index.html">http://www.cisco.com/cisco/web/support/index.html</a> |

## Feature Information for IP Access Lists

Use Cisco Feature Navigator to find information about the platform support and software image support. Cisco Feature Navigator enables you to determine which software images support a specific software release, feature set, or platform. To access Cisco Feature Navigator, go to the <https://cfng.cisco.com/> link. An account on the Cisco.com page is not required.



**Note** The following table lists the software release in which a given feature is introduced. Unless noted otherwise, subsequent releases of that software release train also support that feature.

**Table 238: Feature Information for IP Access Lists**

| Feature Name    | Releases                 | Feature Information                                                                                            |
|-----------------|--------------------------|----------------------------------------------------------------------------------------------------------------|
| IP access lists | Cisco IOS XE Fuji 16.7.1 | This feature was integrated into Cisco IOS XE Fuji 16.7.1 on the Cisco cBR Series Converged Broadband Routers. |







## CHAPTER 69

# Creating an IP Access List and Applying It to an Interface

---

IP access lists provide many benefits for securing a network and achieving nonsecurity goals, such as determining quality of service (QoS) factors or limiting **debug** command output. This module describes how to create standard, extended, named, and numbered IP access lists. An access list can be referenced by a name or a number. Standard access lists filter on only the source address in IP packets. Extended access lists can filter on source address, destination address, and other fields in an IP packet.

After you create an access list, you must apply it to something in order for it to have any effect. This module describes how to apply an access list to an interface. However, there are many other uses for access lists, which are mentioned in this module and described in other modules and in other configuration guides for various technologies.

Your software release may not support all the features that are documented in this module. For the latest feature information and caveats, see the release notes for your platform and software release. The Feature Information Table at the end of this document provides information about the documented features and lists the releases in which each feature is supported.

Use Cisco Feature Navigator to find information about platform support and Cisco software image support. To access Cisco Feature Navigator, go to <http://tools.cisco.com/ITDIT/CFN/>. An account on <http://www.cisco.com/> is not required.

### Contents

- [Hardware Compatibility Matrix for the Cisco cBR Series Routers](#), on page 1142
- [Information About Creating an IP Access List and Applying It to an Interface](#), on page 1143
- [How to Create an IP Access List and Apply It to an Interface](#), on page 1144
- [Configuration Examples for Creating an IP Access List and Applying It to a Physical Interface](#), on page 1153
- [Additional References Creating an IP Access List and Applying It to an Interface](#), on page 1157
- [Feature Information Creating an IP Access List and Applying It to an Interface](#), on page 1158

# Hardware Compatibility Matrix for the Cisco cBR Series Routers



**Note** The hardware components that are introduced in a given Cisco IOS-XE Release are supported in all subsequent releases unless otherwise specified.

**Table 239: Hardware Compatibility Matrix for the Cisco cBR Series Routers**

| Cisco CMTS Platform                    | Processor Engine                                                                                                                                                                                  | Interface Cards                                                                                                                                                                                                                                                                                                                                                                                                                                                                                                                                                                                                                                                                                                                                                                                 |
|----------------------------------------|---------------------------------------------------------------------------------------------------------------------------------------------------------------------------------------------------|-------------------------------------------------------------------------------------------------------------------------------------------------------------------------------------------------------------------------------------------------------------------------------------------------------------------------------------------------------------------------------------------------------------------------------------------------------------------------------------------------------------------------------------------------------------------------------------------------------------------------------------------------------------------------------------------------------------------------------------------------------------------------------------------------|
| Cisco cBR-8 Converged Broadband Router | <p><b>Cisco IOS-XE Release 16.5.1 and Later Releases</b></p> <p>Cisco cBR-8 Supervisor:</p> <ul style="list-style-type: none"> <li>• PID—CBR-SUP-250G</li> <li>• PID—CBR-CCAP-SUP-160G</li> </ul> | <p><b>Cisco IOS-XE Release 16.5.1 and Later Releases</b></p> <p>Cisco cBR-8 CCAP Line Cards:</p> <ul style="list-style-type: none"> <li>• PID—CBR-LC-8D30-16U30</li> <li>• PID—CBR-LC-8D31-16U30</li> <li>• PID—CBR-RF-PIC</li> <li>• PID—CBR-RF-PROT-PIC</li> <li>• PID—CBR-CCAP-LC-40G</li> <li>• PID—CBR-CCAP-LC-40G-R</li> <li>• PID—CBR-CCAP-LC-G2-R</li> <li>• PID—CBR-SUP-8X10G-PIC</li> <li>• PID—CBR-2X100G-PIC</li> </ul> <p>Digital PICs:</p> <ul style="list-style-type: none"> <li>• PID—CBR-DPIC-8X10G</li> <li>• PID—CBR-DPIC-2X100G</li> </ul> <p>Cisco cBR-8 Downstream PHY Module:</p> <ul style="list-style-type: none"> <li>• PID—CBR-D31-DS-MOD</li> </ul> <p>Cisco cBR-8 Upstream PHY Modules:</p> <ul style="list-style-type: none"> <li>• PID—CBR-D31-US-MOD</li> </ul> |



**Note** Do not use DPICs (8X10G and 2x100G) to forward IP traffic, as it may cause buffer exhaustion, leading to line card reload.

The only allowed traffic on a DPIC interface is DEPI, UEPI, and GCP traffic from the Cisco cBR-8 router to Remote PHY devices. Other traffic such as DHCP, SSH, and UTSC should flow via another router, since DPICs cannot be used for normal routing.

## Information About Creating an IP Access List and Applying It to an Interface

### Helpful Hints for Creating IP Access Lists

- Create the access list before applying it to an interface (or elsewhere), because if you apply a nonexistent access list to an interface and then proceed to configure the access list, the first statement is put into effect, and the implicit **deny** statement that follows could cause immediate access problems.
- Another reason to configure an access list before applying it is because an interface with an empty access list applied to it permits all traffic.
- All access lists need at least one **permit** statement; otherwise, all packets are denied and no traffic passes.
- Organize your access list so that more specific references in a network or subnet appear before more general ones.
- A packet will match the first ACE in the ACL. Thus, a **permit ip any any** will match all packets, ignoring all subsequent ACES.
- Although all access lists end with an implicit **deny** statement, we recommend use of an explicit **deny** statement (for example, **deny ip any any**). On most platforms, you can display the count of packets denied by issuing the **show access-list** command, thus finding out more information about who your access list is disallowing. Only packets denied by explicit **deny** statements are counted, which is why the explicit **deny** statement will yield more complete data for you.
- While you are creating an access list or after it is created, you might want to delete an entry. You can delete an entry from a named access list. Use the **no permit** or **no deny** command to delete the appropriate entry.
- In order to make the purpose of individual statements more scannable and easily understood at a glance, you can write a helpful remark before or after any statement by using the **remark** command.
- If you want to deny access to a particular host or network and find out if someone from that network or host is attempting to gain access, include the **log** keyword with the corresponding **deny** statement so that the packets denied from that source are logged for you.
- This hint applies to the placement of your access list. When trying to save resources, remember that an inbound access list applies the filter conditions before the routing table lookup. An outbound access list applies the filter conditions after the routing table lookup.

## Access List Remarks

You can include comments or remarks about entries in any IP access list. An access list remark is an optional remark before or after an access list entry that describes the entry so that you do not have to interpret the purpose of the entry. Each remark is limited to 100 characters in length.

The remark can go before or after a **permit** or **deny** statement. Be consistent about where you add remarks. Users may be confused if some remarks precede the associated **permit** or **deny** statements and some remarks follow the associated statements.

The following is an example of a remark that describes function of the subsequent **deny** statement:

```
ip access-list extended telnetting
remark Do not allow host1 subnet to telnet out
deny tcp host 172.16.2.88 any eq telnet
```

## Additional IP Access List Features

Beyond the basic steps to create a standard or extended access list, you can enhance your access lists as mentioned below. Each of these methods is described completely in the *Refining an IP Access List module*.

- You can impose dates and times when **permit** or **deny** statements in an extended access list are in effect, making your access list more granular and specific to an absolute or periodic time period.
- After you create a named or numbered access list, you might want to add entries or change the order of the entries, which are known as resequencing an access list.
- You can achieve finer granularity when filtering packets by filtering on noninitial fragments of packets.

## How to Create an IP Access List and Apply It to an Interface

This section describes the general ways to create a standard or extended access list using either a name or a number. Access lists are very flexible; the tasks simply illustrate one **permit** command and one **deny** command to provide you the command syntax of each. Only you can determine how many **permit** and **deny** commands you need and their order.



---

**Note** The first two tasks in this module create an access list; you must apply the access list in order for it to function. If you want to apply the access list to an interface, perform the task “Applying the Access List to an Interface”.

---

## Creating a Standard Access List to Filter on Source Address

If you want to filter on source address only, a standard access list is simple and sufficient. There are two alternative types of standard access list: named and numbered. Named access lists allow you to identify your access lists with a more intuitive name rather than a number, and they also support more features than numbered access lists.

## Creating a Named Access List to Filter on Source Address

Use a standard, named access list if you need to filter on source address only. This task illustrates one **permit** statement and one **deny** statement, but the actual statements you use and their order depend on what you want to filter or allow. Define your **permit** and **deny** statements in the order that achieves your filtering goals.

### Step 1 **enable**

#### Example:

```
Device> enable
```

Enables privileged EXEC mode.

- Enter your password if prompted.

### Step 2 **configure terminal**

#### Example:

```
Device# configure terminal
```

Enters global configuration mode.

### Step 3 **ip access-list standard name**

#### Example:

```
Device(config)# ip access-list standard R&D
```

Defines a standard IP access list using a name and enters standard named access list configuration mode.

### Step 4 **remark remark**

#### Example:

```
Device(config-std-nacl)# remark deny Sales network
```

(Optional) Adds a user-friendly comment about an access list entry.

- A remark can precede or follow an access list entry.
- In this example, the remark reminds the network administrator that the subsequent entry denies the Sales network access to the interface (assuming this access list is later applied to an interface).

### Step 5 **deny {source [source-wildcard] | any} [log]**

#### Example:

```
Device(config-std-nacl)# deny 172.16.0.0 0.0.255.255 log
```

(Optional) Denies the specified source based on a source address and wildcard mask.

- If the *source-wildcard* is omitted, a wildcard mask of 0.0.0.0 is assumed, meaning match on all bits of the source address.
- Optionally use the keyword **any** as a substitute for the *source source-wildcard* to specify the source and source wildcard of 0.0.0.0 255.255.255.255.

- In this example, all hosts on network 172.16.0.0 are denied passing the access list.
- Because this example explicitly denies a source address and the **log** keyword is specified, any packets from that source are logged when they are denied. This is a way to be notified that someone on a network or host is trying to gain access.

**Step 6** `remark remark`**Example:**

```
Device(config-std-nacl)# remark Give access to Tester's host
```

(Optional) Adds a user-friendly comment about an access list entry.

- A remark can precede or follow an access list entry.
- This remark reminds the network administrator that the subsequent entry allows the Tester's host access to the interface.

**Step 7** `permit {source [source-wildcard] | any} [log]`**Example:**

```
Device(config-std-nacl)# permit 172.18.5.22 0.0.0.0
```

Permits the specified source based on a source address and wildcard mask.

- Every access list needs at least one **permit** statement; it need not be the first entry.
- If the *source-wildcard* is omitted, a wildcard mask of 0.0.0.0 is assumed, meaning match on all bits of the source address.
- Optionally use the keyword **any** as a substitute for the *source source-wildcard* to specify the source and source wildcard of 0.0.0.0 255.255.255.255.
- In this example, host 172.18.5.22 is allowed to pass the access list.

**Step 8** Repeat some combination of Steps 4 through 7 until you have specified the sources on which you want to base your access list.

Remember that all sources not specifically permitted are denied by an implicit **deny** statement at the end of the access list.

**Step 9** `end`**Example:**

```
Device(config-std-nacl)# end
```

Exits standard named access list configuration mode and enters privileged EXEC mode.

**Step 10** `show ip access-list`**Example:**

```
Device# show ip access-list
```

(Optional) Displays the contents of all current IP access lists.

---

## Creating a Numbered Access List to Filter on Source Address

Configure a standard, numbered access list if you need to filter on source address only and you prefer not to use a named access list.

IP standard access lists are numbered 1 to 99 or 1300 to 1999. This task illustrates one **permit** statement and one **deny** statement, but the actual statements you use and their order depend on what you want to filter or allow. Define your **permit** and **deny** statements in the order that achieves your filtering goals.

---

### Step 1 enable

#### Example:

```
Device> enable
```

Enables privileged EXEC mode.

- Enter your password if prompted.

### Step 2 configure terminal

#### Example:

```
Device# configure terminal
```

Enters global configuration mode.

### Step 3 access-list *access-list-number* permit {*source* [*source-wildcard*] | any} [log]

#### Example:

```
Device(config)# access-list 1 permit 172.16.5.22 0.0.0.0
```

Permits the specified source based on a source address and wildcard mask.

- Every access list needs at least one permit statement; it need not be the first entry.
- Standard IP access lists are numbered 1 to 99 or 1300 to 1999.
- If the source-wildcard is omitted, a wildcard mask of 0.0.0.0 is assumed, meaning match on all bits of the source address.
- Optionally use the keyword any as a substitute for the source source-wildcard to specify the source and source wildcard of 0.0.0.0 255.255.255.255.
- In this example, host 172.16.5.22 is allowed to pass the access list.

### Step 4 access-list *access-list-number* deny {*source* [*source-wildcard*] | any} [log]

#### Example:

```
Device(config)# access-list 1 deny 172.16.7.34 0.0.0.0
```

Denies the specified source based on a source address and wildcard mask.

- If the *source-wildcard* is omitted, a wildcard mask of 0.0.0.0 is assumed, meaning match on all bits of the source address.
- Optionally use the abbreviation **any** as a substitute for the *source source-wildcard* to specify the source and source wildcard of 0.0.0.0 255.255.255.255.
- In this example, host 172.16.7.34 is denied passing the access list.

**Step 5** Repeat some combination of Steps 3 through 6 until you have specified the sources on which you want to base your access list.

Remember that all sources not specifically permitted are denied by an implicit **deny** statement at the end of the access list.

**Step 6** **end**

**Example:**

```
Device(config)# end
```

Exits global configuration mode and enters privileged EXEC mode.

**Step 7** **show ip access-list**

**Example:**

```
Device# show ip access-list
```

(Optional) Displays the contents of all current IP access lists.

## Creating an Extended Access List

If you want to filter on anything other than source address, you need to create an extended access list. There are two alternative types of extended access list: named and numbered. Named access lists allow you to identify your access lists with a more intuitive name rather than a number, and they also support more features.

For details on how to filter something other than source or destination address, see the syntax descriptions in the command reference documentation.

### Creating a Named Extended Access List

Create a named extended access list if you want to filter the source and destination address or filter a combination of addresses and other IP fields.

#### SUMMARY STEPS

1. **enable**
2. **configure terminal**
3. **ip access-list extended *name***



4. **deny** *protocol source [source-wildcard] destination [destination-wildcard] [option option-name] [precedence precedence] [tos tos] [established] [log | log-input] [time-range time-range-name] [fragments]*
5. **permit** *protocol source [source-wildcard] destination [destination-wildcard] [option option-name] [precedence precedence] [tos tos] [established] [log | log-input] [time-range time-range-name] [fragments]*
6. Repeat some combination of Steps 4 through 7 until you have specified the fields and values on which you want to base your access list.
7. **end**
8. **show ip access-list**

## DETAILED STEPS

|        | Command or Action                                                                                                                                                                                                                                                                                                    | Purpose                                                                                                                                                                                                                                                                                                                                                                                                                                                                                                                                                                                                                                                                                                                                                                                                                                                                                                                                                                                                                                                 |
|--------|----------------------------------------------------------------------------------------------------------------------------------------------------------------------------------------------------------------------------------------------------------------------------------------------------------------------|---------------------------------------------------------------------------------------------------------------------------------------------------------------------------------------------------------------------------------------------------------------------------------------------------------------------------------------------------------------------------------------------------------------------------------------------------------------------------------------------------------------------------------------------------------------------------------------------------------------------------------------------------------------------------------------------------------------------------------------------------------------------------------------------------------------------------------------------------------------------------------------------------------------------------------------------------------------------------------------------------------------------------------------------------------|
| Step 1 | <b>enable</b><br><b>Example:</b><br>Device> enable                                                                                                                                                                                                                                                                   | Enables privileged EXEC mode. <ul style="list-style-type: none"> <li>• Enter your password if prompted.</li> </ul>                                                                                                                                                                                                                                                                                                                                                                                                                                                                                                                                                                                                                                                                                                                                                                                                                                                                                                                                      |
| Step 2 | <b>configure terminal</b><br><b>Example:</b><br>Device# configure terminal                                                                                                                                                                                                                                           | Enters global configuration mode.                                                                                                                                                                                                                                                                                                                                                                                                                                                                                                                                                                                                                                                                                                                                                                                                                                                                                                                                                                                                                       |
| Step 3 | <b>ip access-list extended name</b><br><b>Example:</b><br>Device(config)# ip access-list extended acl1                                                                                                                                                                                                               | Defines an extended IP access list using a name and enters extended named access list configuration mode.                                                                                                                                                                                                                                                                                                                                                                                                                                                                                                                                                                                                                                                                                                                                                                                                                                                                                                                                               |
| Step 4 | <b>deny protocol source [source-wildcard] destination [destination-wildcard] [option option-name] [precedence precedence] [tos tos] [established] [log   log-input] [time-range time-range-name] [fragments]</b><br><b>Example:</b><br>Device(config-ext-nacl)# deny ip 172.18.0.0 0.0.255.255 host 172.16.40.10 log | (Optional) Denies any packet that matches all of the conditions specified in the statement. <ul style="list-style-type: none"> <li>• If the <i>source-wildcard</i> or <i>destination-wildcard</i> is omitted, a wildcard mask of 0.0.0.0 is assumed, meaning match on all bits of the source or destination address, respectively.</li> <li>• Optionally use the keyword <b>any</b> as a substitute for the <i>source source-wildcard</i> or <i>destination destination-wildcard</i> to specify the address and wildcard of 0.0.0.0 255.255.255.255.</li> <li>• Optionally use the keyword <b>host source</b> to indicate a source and source wildcard of <i>source</i> 0.0.0.0 or the abbreviation <b>host destination</b> to indicate a destination and destination wildcard of <i>destination</i> 0.0.0.0.</li> <li>• In this example, packets from all sources are denied access to the destination network 172.18.0.0. Logging messages about packets permitted or denied by the access list are sent to the facility configured by the</li> </ul> |

|               | Command or Action                                                                                                                                                                                                                                                                                              | Purpose                                                                                                                                                                                                                                                                                                                                                                                                                                                                                                                                                                                                                                                                                                                                                                                                                                                      |
|---------------|----------------------------------------------------------------------------------------------------------------------------------------------------------------------------------------------------------------------------------------------------------------------------------------------------------------|--------------------------------------------------------------------------------------------------------------------------------------------------------------------------------------------------------------------------------------------------------------------------------------------------------------------------------------------------------------------------------------------------------------------------------------------------------------------------------------------------------------------------------------------------------------------------------------------------------------------------------------------------------------------------------------------------------------------------------------------------------------------------------------------------------------------------------------------------------------|
|               |                                                                                                                                                                                                                                                                                                                | <b>logging facility</b> command (for example, console, terminal, or syslog). That is, any packet that matches the access list will cause an informational logging message about the packet to be sent to the configured facility. The level of messages logged to the console is controlled by the <b>logging console</b> command.                                                                                                                                                                                                                                                                                                                                                                                                                                                                                                                           |
| <b>Step 5</b> | <p><b>permit</b> <i>protocol source [source-wildcard] destination [destination-wildcard] [option option-name] [precedence precedence] [tos tos] [established] [log   log-input] [time-range time-range-name] [fragments]</i></p> <p><b>Example:</b></p> <pre>Device(config-ext-nacl)# permit tcp any any</pre> | <p>Permits any packet that matches all of the conditions specified in the statement.</p> <ul style="list-style-type: none"> <li>• Every access list needs at least one permit statement.</li> <li>• If the <i>source-wildcard</i> or <i>destination-wildcard</i> is omitted, a wildcard mask of 0.0.0.0 is assumed, meaning match on all bits of the source or destination address, respectively.</li> <li>• Optionally use the keyword <b>any</b> as a substitute for the <i>source source-wildcard</i> or <i>destination destination-wildcard</i> to specify the address and wildcard of 0.0.0.0 255.255.255.255.</li> <li>• In this example, TCP packets are allowed from any source to any destination.</li> <li>• Use the <b>log-input</b> keyword to include input interface, source MAC address, or virtual circuit in the logging output.</li> </ul> |
| <b>Step 6</b> | Repeat some combination of Steps 4 through 7 until you have specified the fields and values on which you want to base your access list.                                                                                                                                                                        | Remember that all sources not specifically permitted are denied by an implicit <b>deny</b> statement at the end of the access list.                                                                                                                                                                                                                                                                                                                                                                                                                                                                                                                                                                                                                                                                                                                          |
| <b>Step 7</b> | <p><b>end</b></p> <p><b>Example:</b></p> <pre>Device(config-ext-nacl)# end</pre>                                                                                                                                                                                                                               | Exits standard named access list configuration mode and enters privileged EXEC mode.                                                                                                                                                                                                                                                                                                                                                                                                                                                                                                                                                                                                                                                                                                                                                                         |
| <b>Step 8</b> | <p><b>show ip access-list</b></p> <p><b>Example:</b></p> <pre>Device# show ip access-list</pre>                                                                                                                                                                                                                | (Optional) Displays the contents of all current IP access lists.                                                                                                                                                                                                                                                                                                                                                                                                                                                                                                                                                                                                                                                                                                                                                                                             |

## Creating a Numbered Extended Access List

Create a numbered extended access list if you want to filter on source and destination address, or a combination of addresses and other IP fields, and you prefer not to use a name. Extended IP access lists are numbered 100 to 199 or 2000 to 2699.

## SUMMARY STEPS

1. **enable**
2. **configure terminal**
3. **access-list** *access-list-number* **remark** *remark*
4. **access-list** *access-list-number* **permit** *protocol* {*source* [*source-wildcard*] | **any**} {*destination* [*destination-wildcard*] | **any**} [**precedence** *precedence*] [**tos** *tos*] [**established**] [**log** | **log-input**] [**time-range** *time-range-name*] [**fragments**]
5. **access-list** *access-list-number* **remark** *remark*
6. **access-list** *access-list-number* **deny** *protocol* {*source* [*source-wildcard*] | **any**} {*destination* [*destination-wildcard*] | **any**} [**precedence** *precedence*] [**tos** *tos*] [**established**] [**log** | **log-input**] [**time-range** *time-range-name*] [**fragments**]
7. Repeat some combination of Steps 3 through 6 until you have specified the fields and values on which you want to base your access list.
8. **end**
9. **show ip access-list**

## DETAILED STEPS

|        | Command or Action                                                                                                                                                                                                                                                                                                                                                                                                                                                                                                      | Purpose                                                                                                                                                                                                                                                                                                                                                                                                                                                                                                                   |
|--------|------------------------------------------------------------------------------------------------------------------------------------------------------------------------------------------------------------------------------------------------------------------------------------------------------------------------------------------------------------------------------------------------------------------------------------------------------------------------------------------------------------------------|---------------------------------------------------------------------------------------------------------------------------------------------------------------------------------------------------------------------------------------------------------------------------------------------------------------------------------------------------------------------------------------------------------------------------------------------------------------------------------------------------------------------------|
| Step 1 | <b>enable</b><br><b>Example:</b><br><pre>Device&gt; enable</pre>                                                                                                                                                                                                                                                                                                                                                                                                                                                       | Enables privileged EXEC mode. <ul style="list-style-type: none"> <li>• Enter your password if prompted.</li> </ul>                                                                                                                                                                                                                                                                                                                                                                                                        |
| Step 2 | <b>configure terminal</b><br><b>Example:</b><br><pre>Device# configure terminal</pre>                                                                                                                                                                                                                                                                                                                                                                                                                                  | Enters global configuration mode.                                                                                                                                                                                                                                                                                                                                                                                                                                                                                         |
| Step 3 | <b>access-list</b> <i>access-list-number</i> <b>remark</b> <i>remark</i><br><b>Example:</b><br><pre>Device(config)# access-list 107 remark allow Telnet packets from any source to network 172.69.0.0 (headquarters)</pre>                                                                                                                                                                                                                                                                                             | (Optional) Adds a user-friendly comment about an access list entry. <ul style="list-style-type: none"> <li>• A remark of up to 100 characters can precede or follow an access list entry.</li> </ul>                                                                                                                                                                                                                                                                                                                      |
| Step 4 | <b>access-list</b> <i>access-list-number</i> <b>permit</b> <i>protocol</i> { <i>source</i> [ <i>source-wildcard</i> ]   <b>any</b> } { <i>destination</i> [ <i>destination-wildcard</i> ]   <b>any</b> } [ <b>precedence</b> <i>precedence</i> ] [ <b>tos</b> <i>tos</i> ] [ <b>established</b> ] [ <b>log</b>   <b>log-input</b> ] [ <b>time-range</b> <i>time-range-name</i> ] [ <b>fragments</b> ]<br><b>Example:</b><br><pre>Device(config)# access-list 107 permit tcp any 172.69.0.0 0.0.255.255 eq telnet</pre> | Permits any packet that matches all of the conditions specified in the statement. <ul style="list-style-type: none"> <li>• Every access list needs at least one <b>permit</b> statement; it need not be the first entry.</li> <li>• Extended IP access lists are numbered 100 to 199 or 2000 to 2699.</li> <li>• If the <i>source-wildcard</i> or <i>destination-wildcard</i> is omitted, a wildcard mask of 0.0.0.0 is assumed, meaning match on all bits of the source or destination address, respectively.</li> </ul> |

|               | Command or Action                                                                                                                                                                                                                                                                                                                                                                                                                                                                     | Purpose                                                                                                                                                                                                                                                                                                                                                                                                                                                                                                                                          |
|---------------|---------------------------------------------------------------------------------------------------------------------------------------------------------------------------------------------------------------------------------------------------------------------------------------------------------------------------------------------------------------------------------------------------------------------------------------------------------------------------------------|--------------------------------------------------------------------------------------------------------------------------------------------------------------------------------------------------------------------------------------------------------------------------------------------------------------------------------------------------------------------------------------------------------------------------------------------------------------------------------------------------------------------------------------------------|
|               |                                                                                                                                                                                                                                                                                                                                                                                                                                                                                       | <ul style="list-style-type: none"> <li>Optionally use the keyword <b>any</b> as a substitute for the <i>source source-wildcard</i> or <i>destination destination-wildcard</i> to specify the address and wildcard of 0.0.0.0 255.255.255.255.</li> <li>TCP and other protocols have additional syntax available. See the <b>access-list</b> command in the command reference for complete syntax.</li> </ul>                                                                                                                                     |
| <b>Step 5</b> | <b>access-list</b> <i>access-list-number</i> <b>remark</b> <i>remark</i><br><b>Example:</b><br><pre>Device(config)# access-list 107 remark deny all other TCP packets</pre>                                                                                                                                                                                                                                                                                                           | (Optional) Adds a user-friendly comment about an access list entry. <ul style="list-style-type: none"> <li>A remark of up to 100 characters can precede or follow an access list entry.</li> </ul>                                                                                                                                                                                                                                                                                                                                               |
| <b>Step 6</b> | <b>access-list</b> <i>access-list-number</i> <b>deny</b> <i>protocol</i> { <i>source</i> [ <i>source-wildcard</i> ]   <b>any</b> } { <i>destination</i> [ <i>destination-wildcard</i> ]   <b>any</b> } [ <b>precedence</b> <i>precedence</i> ] [ <b>tos</b> <i>tos</i> ] [ <b>established</b> ] [ <b>log</b>   <b>log-input</b> ] [ <b>time-range</b> <i>time-range-name</i> ] [ <b>fragments</b> ]<br><b>Example:</b><br><pre>Device(config)# access-list 107 deny tcp any any</pre> | Denies any packet that matches all of the conditions specified in the statement. <ul style="list-style-type: none"> <li>If the <i>source-wildcard</i> or <i>destination-wildcard</i> is omitted, a wildcard mask of 0.0.0.0 is assumed, meaning match on all bits of the source or destination address, respectively.</li> <li>Optionally use the keyword <b>any</b> as a substitute for the <i>source source-wildcard</i> or <i>destination destination-wildcard</i> to specify the address and wildcard of 0.0.0.0 255.255.255.255.</li> </ul> |
| <b>Step 7</b> | Repeat some combination of Steps 3 through 6 until you have specified the fields and values on which you want to base your access list.                                                                                                                                                                                                                                                                                                                                               | Remember that all sources not specifically permitted are denied by an implicit <b>deny</b> statement at the end of the access list.                                                                                                                                                                                                                                                                                                                                                                                                              |
| <b>Step 8</b> | <b>end</b><br><b>Example:</b><br><pre>Device(config)# end</pre>                                                                                                                                                                                                                                                                                                                                                                                                                       | Exits global configuration mode and enters privileged EXEC mode.                                                                                                                                                                                                                                                                                                                                                                                                                                                                                 |
| <b>Step 9</b> | <b>show ip access-list</b><br><b>Example:</b><br><pre>Device# show ip access-list</pre>                                                                                                                                                                                                                                                                                                                                                                                               | (Optional) Displays the contents of all current IP access lists.                                                                                                                                                                                                                                                                                                                                                                                                                                                                                 |

## Applying an Access List to an Interface

### SUMMARY STEPS

- enable
- configure terminal

3. **interface** *type number*
4. **ip access-group** {*access-list-number* | *access-list-name*} {**in** | **out**}
5. **end**

## DETAILED STEPS

|        | Command or Action                                                                                           | Purpose                                                                                                                                                                                     |
|--------|-------------------------------------------------------------------------------------------------------------|---------------------------------------------------------------------------------------------------------------------------------------------------------------------------------------------|
| Step 1 | <b>enable</b><br><b>Example:</b><br>Device> enable                                                          | Enables privileged EXEC mode. <ul style="list-style-type: none"> <li>• Enter your password if prompted.</li> </ul>                                                                          |
| Step 2 | <b>configure terminal</b><br><b>Example:</b><br>Device# configure terminal                                  | Enters global configuration mode.                                                                                                                                                           |
| Step 3 | <b>interface</b> <i>type number</i><br><b>Example:</b><br>Device(config)# interface TenGigabitEthernet4/1/0 | Specifies an interface and enters interface configuration mode.                                                                                                                             |
| Step 4 | <b>ip access-group</b> { <i>access-list-number</i>   <i>access-list-name</i> } { <b>in</b>   <b>out</b> }   | Applies the specified access list to the inbound interface. <ul style="list-style-type: none"> <li>• To filter source addresses, apply the access list to the inbound interface.</li> </ul> |
| Step 5 | <b>end</b><br><b>Example:</b><br>Device(config-if)# end                                                     | Exits interface configuration mode and returns to privileged EXEC mode.                                                                                                                     |

# Configuration Examples for Creating an IP Access List and Applying It to a Physical Interface

## Example: Filtering on Host Source Address

In the following example, the workstation belonging to user1 is allowed access to Ten Gigabit Ethernet interface 4/1/0, and the workstation belonging to user2 is not allowed access:

```
interface TenGigabitEthernet4/1/0
 ip access-group workstations in
 !
 ip access-list standard workstations
 remark Permit only user1 workstation through
 permit 172.16.2.88
 remark Do not allow user2 workstation through
 deny 172.16.3.13
```

## Example: Filtering on Subnet Source Address

In the following example, the user1 subnet is not allowed access to Ten Gigabit Ethernet interface 4/1/0, but the Main subnet is allowed access:

```
interface TenGigabitEthernet4/1/0
 ip access-group prevention in
!
ip access-list standard prevention
 remark Do not allow user1 subnet through
 deny 172.22.0.0 0.0.255.255
 remark Allow Main subnet
 permit 172.25.0.0 0.0.255.255
```

## Example: Filtering on Source and Destination Addresses and IP Protocols

The following configuration example shows an interface with two access lists, one applied to outgoing packets and one applied to incoming packets. The standard access list named Internet-filter filters outgoing packets on source address. The only packets allowed out the interface must be from source 172.16.3.4.

The extended access list named marketing-group filters incoming packets. The access list permits Telnet packets from any source to network 172.26.0.0 and denies all other TCP packets. It permits any ICMP packets. It denies UDP packets from any source to network 172.26.0.0 on port numbers less than 1024. Finally, the access list denies all other IP packets and performs logging of packets passed or denied by that entry.

```
interface TenGigabitEthernet4/1/0
 ip address 172.20.5.1 255.255.255.0
 ip access-group Internet-filter out
 ip access-group marketing-group in
!
ip access-list standard Internet-filter
 permit 172.16.3.4
ip access-list extended marketing-group
 permit tcp any 172.26.0.0 0.0.255.255 eq telnet
 deny tcp any any
 permit icmp any any
 deny udp any 172.26.0.0 0.0.255.255 lt 1024
 deny ip any any
```

## Example: Filtering on Source Addresses Using a Numbered Access List

In the following example, network 10.0.0.0 is a Class A network whose second octet specifies a subnet; that is, its subnet mask is 255.255.0.0. The third and fourth octets of a network 10.0.0.0 address specify a particular host. Using access list 2, the Cisco IOS-XE software would accept one address on subnet 48 and reject all others on that subnet. The last line of the list shows that the software would accept addresses on all other network 10.0.0.0 subnets.

```
interface TenGigabitEthernet4/1/0
 ip access-group 2 in
!
access-list 2 permit 10.48.0.3
access-list 2 deny 10.48.0.0 0.0.255.255
access-list 2 permit 10.0.0.0 0.255.255.255
```

## Example: Preventing Telnet Access to a Subnet

In the following example, the user1 subnet is not allowed to telnet out of Ten Gigabit Ethernet interface 4/1/0:

```
interface TenGigabitEthernet4/1/0
 ip access-group telnetting out
!
ip access-list extended telnetting
 remark Do not allow user1 subnet to telnet out
 deny tcp 172.20.0.0 0.0.255.255 any eq telnet
 remark Allow Top subnet to telnet out
 permit tcp 172.33.0.0 0.0.255.255 any eq telnet
```

## Example: Filtering on TCP and ICMP Using Port Numbers

In the following example, the first line of the extended access list named acl1 permits any incoming TCP connections with destination ports greater than 1023. The second line permits incoming TCP connections to the Simple Mail Transfer Protocol (SMTP) port of host 172.28.1.2. The last line permits incoming ICMP messages for error feedback.

```
interface TenGigabitEthernet4/1/0
 ip access-group acl1 in
!
ip access-list extended acl1
 permit tcp any 172.28.0.0 0.0.255.255 gt 1023
 permit tcp any host 172.28.1.2 eq 25
 permit icmp any 172.28.0.0 255.255.255.255
```

## Example: Allowing SMTP E-mail and Established TCP Connections

Suppose you have a network connected to the Internet, and you want any host on an Ethernet to be able to form TCP connections to any host on the Internet. However, you do not want IP hosts to be able to form TCP connections to hosts on the Ten Gigabit Ethernet except to the mail (SMTP) port of a dedicated mail host.

SMTP uses TCP port 25 on one end of the connection and a random port number on the other end. The same two port numbers are used throughout the life of the connection. Mail packets coming in from the Internet will have a destination port of 25. Outbound packets will have the port numbers reversed. The fact that the secure system behind the router always will accept mail connections on port 25 is what makes possible separate control of incoming and outgoing services. The access list can be configured on either the outbound or inbound interface.

In the following example, the Ten Gigabit Ethernet network is a Class B network with the address 172.18.0.0, and the address of the mail host is 172.18.1.2. The **established** keyword is used only for the TCP protocol to indicate an established connection. A match occurs if the TCP datagram has the ACK or RST bits set, which indicate that the packet belongs to an existing connection.

```
interface TenGigabitEthernet4/1/0
 ip access-group 102 in
!
access-list 102 permit tcp any 172.18.0.0 0.0.255.255 established
access-list 102 permit tcp any host 172.18.1.2 eq 25
```

## Example: Preventing Access to the Web by Filtering on Port Name

In the following example, the w1 and w2 workstations are not allowed web access; other hosts on network 172.20.0.0 are allowed web access:

```
interface TenGigabitEthernet4/1/0
 ip access-group no-web out
!
ip access-list extended no-web
 remark Do not allow w1 to browse the web
 deny host 172.20.3.85 any eq http
 remark Do not allow w2 to browse the web
 deny host 172.20.3.13 any eq http
 remark Allow others on our network to browse the web
 permit 172.20.0.0 0.0.255.255 any eq http
```

## Example: Filtering on Source Address and Logging the Packets

The following example defines access lists 1 and 2, both of which have logging enabled:

```
interface TenGigabitEthernet4/1/0
 ip address 172.16.1.1 255.0.0.0
 ip access-group 1 in
 ip access-group 2 out
!
access-list 1 permit 172.25.0.0 0.0.255.255 log
access-list 1 deny 172.30.0.0 0.0.255.255 log
!
access-list 2 permit 172.27.3.4 log
access-list 2 deny 172.17.0.0 0.0.255.255 log
```

If the interface receives 10 packets from 172.25.7.7 and 14 packets from 172.17.23.21, the first log will look like the following:

```
list 1 permit 172.25.7.7 1 packet
list 2 deny 172.17.23.21 1 packet
```

Five minutes later, the console will receive the following log:

```
list 1 permit 172.25.7.7 9 packets
list 2 deny 172.17.23.21 13 packets
```

## Example: Limiting Debug Output

The following sample configuration uses an access list to limit the **debug** command output. Limiting the **debug** output restricts the volume of data to what you are interested in, saving you time and resources.

```
Device(config)# ip access-list acl1
Device(config-std-nacl)# remark Displays only advertisements for LDP peer in acl1
Device(config-std-nacl)# permit host 10.0.0.44

Device# debug mpls ldp advertisements peer-acl acl1

tagcon: peer 10.0.0.44:0 (pp 0x60E105BC): advertise 172.17.0.33
tagcon: peer 10.0.0.44:0 (pp 0x60E105BC): advertise 172.16.0.31
tagcon: peer 10.0.0.44:0 (pp 0x60E105BC): advertise 172.22.0.33
```



```

tagcon: peer 10.0.0.44:0 (pp 0x60E105BC): advertise 192.168.0.1
tagcon: peer 10.0.0.44:0 (pp 0x60E105BC): advertise 192.168.0.3
tagcon: peer 10.0.0.44:0 (pp 0x60E105BC): advertise 192.168.1.33

```

## Additional References Creating an IP Access List and Applying It to an Interface

### Related Documents

| Related Topic                                                                                                                                                                             | Document Title                                                                                                                                                                                                                                                                                                                                                               |
|-------------------------------------------------------------------------------------------------------------------------------------------------------------------------------------------|------------------------------------------------------------------------------------------------------------------------------------------------------------------------------------------------------------------------------------------------------------------------------------------------------------------------------------------------------------------------------|
| Security commands                                                                                                                                                                         | <ul style="list-style-type: none"> <li>• <a href="#">Cisco IOS Security Command Reference: Commands A to C</a></li> <li>• <a href="#">Cisco IOS Security Command Reference: Commands D to L</a></li> <li>• <a href="#">Cisco IOS Security Command Reference: Commands M to R</a></li> <li>• <a href="#">Cisco IOS Security Command Reference: Commands S to Z</a></li> </ul> |
| <ul style="list-style-type: none"> <li>• Order of access list entries</li> <li>• Access list entries based on time of day or week</li> <li>• Packets with noninitial fragments</li> </ul> | <a href="#">Refining an IP Access List</a>                                                                                                                                                                                                                                                                                                                                   |
| Filtering on IP options, TCP flags, or noncontiguous ports                                                                                                                                | <a href="#">Creating an IP Access List for Filtering</a>                                                                                                                                                                                                                                                                                                                     |
| Controlling logging-related parameters                                                                                                                                                    | <a href="#">Understanding Access Control List Logging</a>                                                                                                                                                                                                                                                                                                                    |

### Standards and RFCs

| Standard/RFC                                                                                                                                          | Title |
|-------------------------------------------------------------------------------------------------------------------------------------------------------|-------|
| No new or modified standards or RFCs are supported by this feature, and support for existing standards or RFCs has not been modified by this feature. | —     |

**Technical Assistance**

| Description                                                                                                                                                                                                                                                                                                                                                                           | Link                                                                                                              |
|---------------------------------------------------------------------------------------------------------------------------------------------------------------------------------------------------------------------------------------------------------------------------------------------------------------------------------------------------------------------------------------|-------------------------------------------------------------------------------------------------------------------|
| The Cisco Support and Documentation website provides online resources to download documentation, software, and tools. Use these resources to install and configure the software and to troubleshoot and resolve technical issues with Cisco products and technologies. Access to most tools on the Cisco Support and Documentation website requires a Cisco.com user ID and password. | <a href="http://www.cisco.com/cisco/web/support/index.html">http://www.cisco.com/cisco/web/support/index.html</a> |

## Feature Information Creating an IP Access List and Applying It to an Interface

Use Cisco Feature Navigator to find information about the platform support and software image support. Cisco Feature Navigator enables you to determine which software images support a specific software release, feature set, or platform. To access Cisco Feature Navigator, go to the <https://cfng.cisco.com/> link. An account on the Cisco.com page is not required.



**Note** The following table lists the software release in which a given feature is introduced. Unless noted otherwise, subsequent releases of that software release train also support that feature.

**Table 240: Feature Information for Creating an IP Access List and Applying It to an Interface**

| Feature Name    | Releases                 | Feature Information                                                                                            |
|-----------------|--------------------------|----------------------------------------------------------------------------------------------------------------|
| IP access lists | Cisco IOS XE Fuji 16.7.1 | This feature was integrated into Cisco IOS XE Fuji 16.7.1 on the Cisco cBR Series Converged Broadband Routers. |



## CHAPTER 70

# Creating an IP Access List to Filter IP Options, TCP Flags, Noncontiguous Ports

This module describes how to use an IP access list to filter IP packets that contain certain IP Options, TCP flags, noncontiguous ports.

Your software release may not support all the features that are documented in this module. For the latest feature information and caveats, see the release notes for your platform and software release. The Feature Information Table at the end of this document provides information about the documented features and lists the releases in which each feature is supported.

Use Cisco Feature Navigator to find information about platform support and Cisco software image support. To access Cisco Feature Navigator, go to <http://tools.cisco.com/ITDIT/CFN/>. An account on <http://www.cisco.com/> is not required.

### Contents

- [Hardware Compatibility Matrix for the Cisco cBR Series Routers](#), on page 1159
- [Prerequisites for Creating an IP Access List to Filter IP Options TCP Flags Noncontiguous Ports](#) , on page 1161
- [Information About Creating an IP Access List to Filter IP Options, TCP Flags, Noncontiguous Ports](#) , on page 1161
- [How to Create an IP Access List to Filter IP Options TCP Flags Noncontiguous Ports](#) , on page 1164
- [Configuration Examples for Filtering IP Options, TCP Flags, Noncontiguous Ports](#) , on page 1175
- [Additional References](#), on page 1178
- [Feature Information for Creating an IP Access List to Filter IP Options, TCP Flags, Noncontiguous Ports, or TTL Values](#), on page 1179

## Hardware Compatibility Matrix for the Cisco cBR Series Routers



**Note** The hardware components that are introduced in a given Cisco IOS-XE Release are supported in all subsequent releases unless otherwise specified.

Table 241: Hardware Compatibility Matrix for the Cisco cBR Series Routers

| Cisco CMTS Platform                    | Processor Engine                                                                                                                                                                                  | Interface Cards                                                                                                                                                                                                                                                                                                                                                                                                                                                                                                                                                                                                                                                                                                                                                                                 |
|----------------------------------------|---------------------------------------------------------------------------------------------------------------------------------------------------------------------------------------------------|-------------------------------------------------------------------------------------------------------------------------------------------------------------------------------------------------------------------------------------------------------------------------------------------------------------------------------------------------------------------------------------------------------------------------------------------------------------------------------------------------------------------------------------------------------------------------------------------------------------------------------------------------------------------------------------------------------------------------------------------------------------------------------------------------|
| Cisco cBR-8 Converged Broadband Router | <p><b>Cisco IOS-XE Release 16.5.1 and Later Releases</b></p> <p>Cisco cBR-8 Supervisor:</p> <ul style="list-style-type: none"> <li>• PID—CBR-SUP-250G</li> <li>• PID—CBR-CCAP-SUP-160G</li> </ul> | <p><b>Cisco IOS-XE Release 16.5.1 and Later Releases</b></p> <p>Cisco cBR-8 CCAP Line Cards:</p> <ul style="list-style-type: none"> <li>• PID—CBR-LC-8D30-16U30</li> <li>• PID—CBR-LC-8D31-16U30</li> <li>• PID—CBR-RF-PIC</li> <li>• PID—CBR-RF-PROT-PIC</li> <li>• PID—CBR-CCAP-LC-40G</li> <li>• PID—CBR-CCAP-LC-40G-R</li> <li>• PID—CBR-CCAP-LC-G2-R</li> <li>• PID—CBR-SUP-8X10G-PIC</li> <li>• PID—CBR-2X100G-PIC</li> </ul> <p>Digital PICs:</p> <ul style="list-style-type: none"> <li>• PID—CBR-DPIC-8X10G</li> <li>• PID—CBR-DPIC-2X100G</li> </ul> <p>Cisco cBR-8 Downstream PHY Module:</p> <ul style="list-style-type: none"> <li>• PID—CBR-D31-DS-MOD</li> </ul> <p>Cisco cBR-8 Upstream PHY Modules:</p> <ul style="list-style-type: none"> <li>• PID—CBR-D31-US-MOD</li> </ul> |



**Note** Do not use DPICs (8X10G and 2x100G) to forward IP traffic, as it may cause buffer exhaustion, leading to line card reload.

The only allowed traffic on a DPIC interface is DEPI, UEPI, and GCP traffic from the Cisco cBR-8 router to Remote PHY devices. Other traffic such as DHCP, SSH, and UTSC should flow via another router, since DPICs cannot be used for normal routing.

# Prerequisites for Creating an IP Access List to Filter IP Options TCP Flags Noncontiguous Ports

Before you perform any of the tasks in this module, you should be familiar with the information in the following modules:

- “IP Access List Overview”
- “Creating an IP Access List and Applying It to an Interface”

## Information About Creating an IP Access List to Filter IP Options, TCP Flags, Noncontiguous Ports

### IP Options

IP uses four key mechanisms in providing its service: Type of Service, Time to Live, Options, and Header Checksum.

The Options, commonly referred to as IP Options, provide for control functions that are required in some situations but unnecessary for the most common communications. IP Options include provisions for time stamps, security, and special routing.

IP Options may or may not appear in datagrams. They must be implemented by all IP modules (host and gateways). What is optional is their transmission in any particular datagram, not their implementation. In some environments the security option may be required in all datagrams.

The option field is variable in length. There may be zero or more options. IP Options can have one of two formats:

- Format 1: A single octet of option-type.
- Format 2: An option-type octet, an option-length octet, and the actual option-data octets.

The option-length octet counts the option-type octet, the option-length octet, and the option-data octets.

The option-type octet is viewed as having three fields: a 1-bit copied flag, a 2-bit option class, and a 5-bit option number. These fields form an 8-bit value for the option type field. IP Options are commonly referred to by their 8-bit value.

For a complete list and description of IP Options, refer to RFC 791, *Internet Protocol* at the following URL: <http://www.faqs.org/rfcs/rfc791.html>

### Benefits of Filtering IP Options

- Filtering of packets that contain IP Options from the network relieves downstream devices and hosts of the load from options packets.

- This feature also minimizes load to the Route Processor (RP) for packets with IP Options that require RP processing on distributed systems. Previously, the packets were always routed to or processed by the RP CPU. Filtering the packets prevents them from impacting the RP.

## Benefits of Filtering on TCP Flags

The ACL TCP Flags Filtering feature provides a flexible mechanism for filtering on TCP flags. Previously, an incoming packet was matched as long as any TCP flag in the packet matched a flag specified in the access control entry (ACE). This behavior allows for a security loophole, because packets with all flags set could get past the access control list (ACL). The ACL TCP Flags Filtering feature allows you to select any combination of flags on which to filter. The ability to match on a flag set and on a flag not set gives you a greater degree of control for filtering on TCP flags, thus enhancing security.

Because TCP packets can be sent as false synchronization packets that can be accepted by a listening port, it is recommended that administrators of firewall devices set up some filtering rules to drop false TCP packets.

The ACEs that make up an access list can be configured to detect and drop unauthorized TCP packets by allowing only the packets that have a very specific group of TCP flags set or not set. The ACL TCP Flags Filtering feature provides a greater degree of packet-filtering control in the following ways:

- You can select any desired combination of TCP flags on which to filter TCP packets.
- You can configure ACEs to allow matching on a flag that is set, as well as on a flag that is not set.

## TCP Flags

The table below lists the TCP flags, which are further described in RFC 793, *Transmission Control Protocol*.

**Table 242: TCP Flags**

| TCP Flag | Purpose                                                                                                                                                      |
|----------|--------------------------------------------------------------------------------------------------------------------------------------------------------------|
| ACK      | Acknowledge flag—Indicates that the acknowledgment field of a segment specifies the next sequence number the sender of this segment is expecting to receive. |
| FIN      | Finish flag—Used to clear connections.                                                                                                                       |
| PSH      | Push flag—Indicates the data in the call should be immediately pushed through to the receiving user.                                                         |
| RST      | Reset flag—Indicates that the receiver should delete the connection without further interaction.                                                             |
| SYN      | Synchronize flag—Used to establish connections.                                                                                                              |
| URG      | Urgent flag—Indicates that the urgent field is meaningful and must be added to the segment sequence number.                                                  |

## Benefits of Using the Named ACL Support for Noncontiguous Ports on an Access Control Entry Feature

This feature greatly reduces the number of access control entries (ACEs) required in an access control list to handle multiple entries for the same source address, destination address, and protocol. If you maintain large numbers of ACEs, use this feature to consolidate existing groups of access list entries wherever it is possible and when you create new access list entries. When you configure access list entries with noncontiguous ports, you will have fewer access list entries to maintain.

## How Filtering on TTL Value Works

IP extended named and numbered access lists may filter on the TTL value of packets arriving at or leaving an interface. Packets with any possible TTL values 0 through 255 may be permitted or denied (filtered). Like filtering on other fields, such as source or destination address, the **ip access-group** command specifies **in** or **out**, which makes the access list ingress or egress and applies it to incoming or outgoing packets, respectively. The TTL value is checked in conjunction with the specified protocol, application, and any other settings in the access list entry, and all conditions must be met.

### Special Handling for Packets with TTL Value of 0 or 1 Arriving at an Ingress Interface

The software switching paths—distributed Cisco Express Forwarding (dCEF), CEF, fast switching, and process switching—will usually permit or discard the packets based on the access list statements. However, when the TTL value of packets arriving at an ingress interface have a TTL of 0 or 1, special handling is required. The packets with a TTL value of 0 or 1 get sent to the process level before the ingress access list is checked in CEF, dCEF, or the fast switching paths. The ingress access list is applied to packets with TTL values 2 through 255 and a permit or deny decision is made.

Packets with a TTL value of 0 or 1 are sent to the process level because they will never be forwarded out of the device; the process level must check whether each packet is destined for the device and whether an Internet Control Message Protocol (ICMP) TTL Expire message needs to be sent back. This means that even if an ACL with TTL value 0 or 1 filtering is configured on the ingress interface with the intention to drop packets with a TTL of 0 or 1, the dropping of the packets will not happen in the faster paths. It will instead happen in the process level when the process applies the ACL. This is also true for hardware switching platforms. Packets with TTL value of 0 or 1 are sent to the process level of the route processor (RP) or Multilayer Switch Feature Card (MSFC).

On egress interfaces, access list filtering on TTL value works just like other access list features. The check will happen in the fastest switching path enabled in the device. This is because the faster switching paths handle all the TTL values (0 through 255) equally on the egress interface.

### Control Plane Policing for Filtering TTL Values 0 and 1

The special behavior for packets with a TTL value of 0 or 1 results in higher CPU usage for the device. If you are filtering on TTL value of 0 or 1, you should use control plane policing (CPP) to protect the CPU from being overwhelmed. In order to leverage CPP, you must configure an access list especially for filtering TTL values 0 and 1 and apply the access list through CPP. This access list will be a separate access list from any other interface access lists. Because CPP works for the entire system, not just on individual interfaces, you would need to configure only one such special access list for the entire device. This task is described in the section "Enabling Control Plane Policing to Filter on TTL Values 0 and 1".

## Benefits of Filtering on TTL Value

- Filtering on time-to-live (TTL) value provides a way to control which packets are allowed to reach the device or are prevented from reaching the device. By looking at your network layout, you can choose whether to accept or deny packets from a certain device based on how many hops away it is. For example, in a small network, you can deny packets from a location more than three hops away. Filtering on TTL value allows you to validate if the traffic originated from a neighboring device. You can accept only packets that reach you in one hop, for example, by accepting only packets with a TTL value of one less than the initial TTL value of a particular protocol.
- Many control plane protocols communicate only with their neighbors, but receive packets from everyone. By applying an access list that filters on TTL to receiving routers, you can block unwanted packets.
- The Cisco software sends all packets with a TTL value of 0 or 1 to the process level. The device must then send an Internet Control Message Protocol (ICMP) TTL value expire message to the source. By filtering packets that have a TTL value of 0 through 2, you can reduce the load on the process level.

# How to Create an IP Access List to Filter IP Options TCP Flags Noncontiguous Ports

## Filtering Packets That Contain IP Options

Complete these steps to configure an access list to filter packets that contain IP options and to verify that the access list has been configured correctly.



### Note

- The ACL Support for Filtering IP Options feature can be used only with named, extended ACLs.
- Resource Reservation Protocol (RSVP) Multiprotocol Label Switching Traffic Engineering (MPLS TE), Internet Group Management Protocol Version 2 (IGMPV2), and other protocols that use IP options packets may not function in drop or ignore mode if this feature is configured.
- On most Cisco devices, a packet with IP options is not switched in hardware, but requires control plane software processing (primarily because there is a need to process the options and rewrite the IP header), so all IP packets with IP options will be filtered and switched in software.

**Step 1**    **enable**

**Example:**

```
Device> enable
```

Enables privileged EXEC mode.

- Enter your password if prompted.

**Step 2**    **configure terminal**

**Example:**

```
Device# configure terminal
```



Enters global configuration mode.

**Step 3** `ip access-list extended access-list-name`

**Example:**

```
Device(config)# ip access-list extended mylist1
```

Specifies the IP access list by name and enters named access list configuration mode.

**Step 4** `[sequence-number] deny protocol source source-wildcard destination destination-wildcard [option option-value] [precedence precedence] [tos tos] [log] [time-range time-range-name] [fragments]`

**Example:**

```
Device(config-ext-nacl)# deny ip any any option traceroute
```

(Optional) Specifies a **deny** statement in named IP access list mode.

- This access list happens to use a **deny** statement first, but a **permit** statement could appear first, depending on the order of statements you need.
- Use the **option** keyword and *option-value* argument to filter packets that contain a particular IP Option.
- In this example, any packet that contains the traceroute IP option will be filtered out.
- Use the **no sequence-number** form of this command to delete an entry.

**Step 5** `[sequence-number] permit protocol source source-wildcard destination destination-wildcard [option option-value] [precedence precedence] [tos tos] [log] [time-range time-range-name] [fragments]`

**Example:**

```
Device(config-ext-nacl)# permit ip any any option security
```

Specifies a **permit** statement in named IP access list mode.

- In this example, any packet (not already filtered) that contains the security IP option will be permitted.
- Use the **no sequence-number** form of this command to delete an entry.

**Step 6** Repeat Step 4 or Step 5 as necessary.

Allows you to revise the access list.

**Step 7** `end`

**Example:**

```
Device(config-ext-nacl)# end
```

(Optional) Exits named access list configuration mode and returns to privileged EXEC mode.

**Step 8** `show ip access-lists access-list-name`

**Example:**

```
Device# show ip access-lists mylist1
```

(Optional) Displays the contents of the IP access list.

## What to Do Next

Apply the access list to an interface or reference it from a command that accepts an access list.



---

**Note** To effectively eliminate all packets that contain IP Options, we recommend that you configure the global **ip options drop** command.

---

## Filtering Packets That Contain TCP Flags

This task configures an access list to filter packets that contain TCP flags and verifies that the access list has been configured correctly.



---

**Note**

- TCP flag filtering can be used only with named, extended ACLs.
- The ACL TCP Flags Filtering feature is supported only for Cisco ACLs.
- Previously, the following command-line interface (CLI) format could be used to configure a TCP flag-checking mechanism:

**permit tcp any any rst** The following format that represents the same ACE can now be used: **permit tcp any any match-any +rst** Both the CLI formats are accepted; however, if the new keywords **match-all** or **match-any** are chosen, they must be followed by the new flags that are prefixed with “+” or “-”. It is advisable to use only the old format or the new format in a single ACL. You cannot mix and match the old and new CLI formats.

---



---

**Caution** If a device having ACEs with the new syntax format is reloaded with a previous version of the Cisco software that does not support the ACL TCP Flags Filtering feature, the ACEs will not be applied, leading to possible security loopholes.

---

**Step 1**    **enable**

**Example:**

```
Device> enable
```

Enables privileged EXEC mode.

- Enter your password if prompted.

**Step 2**    **configure terminal**

**Example:**

```
Device# configure terminal
```

Enters global configuration mode.

**Step 3**    **ip access-list extended** *access-list-name*

**Example:**

```
Device(config)# ip access-list extended kmd1
```

Specifies the IP access list by name and enters named access list configuration mode.

**Step 4** `[sequence-number] permit tcp source source-wildcard [operator [port]] destination destination-wildcard [operator [port]] [established]{match-any | match-all} {+ | -} flag-name [precedence precedence] [tos tos] [log] [time-range time-range-name] [fragments]`

**Example:**

```
Device(config-ext-nacl)# permit tcp any any match-any +rst
```

Specifies a **permit** statement in named IP access list mode.

- This access list happens to use a **permit** statement first, but a **deny** statement could appear first, depending on the order of statements you need.
- Use the TCP command syntax of the **permit** command.
- Any packet with the RST TCP header flag set will be matched and allowed to pass the named access list kmd1 in Step 3.

**Step 5** `[sequence-number] deny tcp source source-wildcard [operator [port]] destination destination-wildcard [operator [port]] [established]{match-any | match-all} {+ | -} flag-name [precedence precedence] [tos tos] [log] [time-range time-range-name] [fragments]`

**Example:**

```
Device(config-ext-nacl)# deny tcp any any match-all -ack -fin
```

(Optional) Specifies a **deny** statement in named IP access list mode.

- This access list happens to use a **permit** statement first, but a **deny** statement could appear first, depending on the order of statements you need.
- Use the TCP command syntax of the **deny** command.
- Any packet that does not have the ACK flag set, and also does not have the FIN flag set, will not be allowed to pass the named access list kmd1 in Step 3.
- See the **deny**(IP) command for additional command syntax to permit upper-layer protocols (ICMP, IGMP, TCP, and UDP).

**Step 6** Repeat Step 4 or Step 5 as necessary, adding statements by sequence number where you planned. Use the **no sequence-number** command to delete an entry.

Allows you to revise the access list.

**Step 7** **end**

**Example:**

```
Device(config-ext-nacl)# end
```

(Optional) Exits the configuration mode and returns to privileged EXEC mode.

**Step 8** **show ip access-lists** *access-list-name*

**Example:**

```
Device# show ip access-lists kmdl
```

(Optional) Displays the contents of the IP access list.

- Review the output to confirm that the access list includes the new entry.

## Configuring an Access Control Entry with Noncontiguous Ports

Perform this task to create access list entries that use noncontiguous TCP or UDP port numbers. Although this task uses TCP ports, you could use the UDP syntax of the **permit** and **deny** commands to filter noncontiguous UDP ports.

Although this task uses a **permit** command first, use the **permit** and **deny** commands in the order that achieves your filtering goals.



**Note** The ACL—Named ACL Support for Noncontiguous Ports on an Access Control Entry feature can be used only with named, extended ACLs.

### Step 1 enable

**Example:**

```
Device> enable
```

Enables privileged EXEC mode.

- Enter your password if prompted.

### Step 2 configure terminal

**Example:**

```
Device# configure terminal
```

Enters global configuration mode.

### Step 3 ip access-list extended *access-list-name*

**Example:**

```
Device(config)# ip access-list extended acl-extd-1
```

Specifies the IP access list by name and enters named access list configuration mode.

### Step 4 [*sequence-number*] **permit tcp** *source source-wildcard* [*operator port* [*port*]] *destination destination-wildcard* [*operator* [*port*]] [**established** {**match-any** | **match-all**} {+ | -} *flag-name*] [**precedence** *precedence*] [**tos** *tos*] [**log**] [**time-range** *time-range-name*] [**fragments**]

**Example:**

```
Device(config-ext-nacl)# permit tcp any eq telnet ftp any eq 450 679
```

Specifies a **permit** statement in named IP access list configuration mode.

- Operators include **lt** (less than), **gt** (greater than), **eq** (equal), **neq** (not equal), and **range** (inclusive range).
- If the operator is positioned after the source and source-wildcard arguments, it must match the source port. If the operator is positioned after the destination and destination-wildcard arguments, it must match the destination port.
- The **range** operator requires two port numbers. You can configure up to 10 ports after the **eq** and **neq** operators. All other operators require one port number.
- To filter UDP ports, use the UDP syntax of this command.

**Step 5** `[sequence-number] deny tcp source source-wildcard [operator port [port]] destination destination-wildcard [operator [port]] [established {match-any | match-all} {+ | -} flag-name] [precedence precedence] [tos tos] [log] [time-range time-range-name] [fragments]`

**Example:**

```
Device(config-ext-nacl)# deny tcp any neq 45 565 632 any
```

(Optional) Specifies a **deny** statement in named access list configuration mode.

- Operators include **lt** (less than), **gt** (greater than), **eq** (equal), **neq** (not equal), and **range** (inclusive range).
- If the *operator* is positioned after the *source* and *source-wildcard* arguments, it must match the source port. If the *operator* is positioned after the *destination* and *destination-wildcard* arguments, it must match the destination port.
- The **range** operator requires two port numbers. You can configure up to 10 ports after the **eq** and **neq** operators. All other operators require one port number.
- To filter UDP ports, use the UDP syntax of this command.

**Step 6** Repeat Step 4 or Step 5 as necessary, adding statements by sequence number where you planned. Use the **no sequence-number** command to delete an entry.

Allows you to revise the access list.

**Step 7** **end**

**Example:**

```
Device(config-ext-nacl)# end
```

(Optional) Exits named access list configuration mode and returns to privileged EXEC mode.

**Step 8** **show ip access-lists** *access-list-name*

**Example:**

```
Device# show ip access-lists kmdl
```

(Optional) Displays the contents of the access list.

## Consolidating Access List Entries with Noncontiguous Ports into One Access List Entry

Perform this task to consolidate a group of access list entries with noncontiguous ports into one access list entry.

Although this task uses TCP ports, you could use the UDP syntax of the **permit** and **deny** commands to filter noncontiguous UDP ports.

Although this task uses a **permit** command first, use the **permit** and **deny** commands in the order that achieves your filtering goals.

### Step 1 enable

#### Example:

```
Device> enable
```

Enables privileged EXEC mode.

- Enter your password if prompted.

### Step 2 show ip access-lists *access-list-name*

#### Example:

```
Device# show ip access-lists mylist1
```

(Optional) Displays the contents of the IP access list.

- Review the output to see if you can consolidate any access list entries.

### Step 3 configure terminal

#### Example:

```
Device# configure terminal
```

Enters global configuration mode.

### Step 4 ip access-list extended *access-list-name*

#### Example:

```
Device(config)# ip access-list extended mylist1
```

Specifies the IP access list by name and enters named access list configuration mode.

### Step 5 no [*sequence-number*] permit protocol source source-wildcard destination destination-wildcard[option option-name] [precedence precedence][tos tos] [log] [time-range time-range-name] [fragments]

#### Example:

```
Device(config-ext-nacl)# no 10
```

Removes the redundant access list entry that can be consolidated.

- Repeat this step to remove entries to be consolidated because only the port numbers differ.
- After this step is repeated to remove the access list entries 20, 30, and 40, for example, those entries are removed because they will be consolidated into one **permit** statement.
- If a *sequence-number* is specified, the rest of the command syntax is optional.

### Step 6 [*sequence-number*] permit protocol source source-wildcard[operator port[port]] destination destination-wildcard[operator port[port]] [option option-name] [precedence precedence][tos tos] [log] [time-range time-range-name] [fragments]

#### Example:

```
Device(config-ext-nacl)# permit tcp any neq 45 565 632 any eq 23 45 34 43
```

Specifies a **permit** statement in named access list configuration mode.

- In this instance, a group of access list entries with noncontiguous ports was consolidated into one **permit** statement.
- You can configure up to 10 ports after the **eq** and **neq** operators.

**Step 7** Repeat Steps 5 and 6 as necessary, adding **permit** or **deny** statements to consolidate access list entries where possible. Use the **no sequence-number** command to delete an entry.

Allows you to revise the access list.

**Step 8** **end**

**Example:**

```
Device(config-std-nacl)# end
```

(Optional) Exits named access list configuration mode and returns to privileged EXEC mode.

**Step 9** **show ip access-lists** *access-list-name*

**Example:**

```
Device# show ip access-lists mylist1
```

(Optional) Displays the contents of the access list.

## What To Do Next

Apply the access list to an interface or reference it from a command that accepts an access list.

## Filtering Packets Based on TTL Value

Because access lists are very flexible, it is not possible to define only one combination of **permit** and **deny** commands to filter packets based on the TTL value. This task illustrates just one example that achieves TTL filtering. Configure the appropriate **permit** and **deny** statements that will accomplish your filtering plan.



**Note** When the access list specifies the operation EQ or NEQ, depending on the Cisco software release in use on the device, the access lists can specify up to ten TTL values. The number of TTL values can vary by the Cisco software release.

### SUMMARY STEPS

1. **enable**
2. **configure terminal**
3. **ip access-list extended** *access-list-name*
4. [*sequence-number*] **permit** *protocol source source-wildcard destination destination-wildcard*[**option** *option-name*] [**precedence** *precedence*] [**tos** *tos*] [**ttl operator value**] [**log**] [**time-range** *time-range-name*] [**fragments**]
5. Continue to add **permit** or **deny** statements to achieve the filtering you want.

6. **exit**
7. **interface** *type number*
8. **ip access-group** *access-list-name* {**in** | **out**}

## DETAILED STEPS

|               | Command or Action                                                                                                                                                                                                                                                                                                                                                                                                                  | Purpose                                                                                                                                                                                                                                                                                                 |
|---------------|------------------------------------------------------------------------------------------------------------------------------------------------------------------------------------------------------------------------------------------------------------------------------------------------------------------------------------------------------------------------------------------------------------------------------------|---------------------------------------------------------------------------------------------------------------------------------------------------------------------------------------------------------------------------------------------------------------------------------------------------------|
| <b>Step 1</b> | <b>enable</b><br><b>Example:</b><br>Device> enable                                                                                                                                                                                                                                                                                                                                                                                 | Enables privileged EXEC mode. <ul style="list-style-type: none"> <li>• Enter your password if prompted.</li> </ul>                                                                                                                                                                                      |
| <b>Step 2</b> | <b>configure terminal</b><br><b>Example:</b><br>Device# configure terminal                                                                                                                                                                                                                                                                                                                                                         | Enters global configuration mode.                                                                                                                                                                                                                                                                       |
| <b>Step 3</b> | <b>ip access-list extended</b> <i>access-list-name</i><br><b>Example:</b><br>Device(config)# ip access-list extended ttlfilter                                                                                                                                                                                                                                                                                                     | Defines an IP access list by name. <ul style="list-style-type: none"> <li>• An access list that filters on TTL value must be an extended access list.</li> </ul>                                                                                                                                        |
| <b>Step 4</b> | [ <i>sequence-number</i> ] <b>permit</b> <i>protocol source source-wildcard destination destination-wildcard</i> [ <b>option</b> <i>option-name</i> ]<br>[ <b>precedence</b> <i>precedence</i> ] [ <b>tos</b> <i>tos</i> ] [ <b>ttl operator value</b> ] [ <b>log</b> ]<br>[ <b>time-range</b> <i>time-range-name</i> ] [ <b>fragments</b> ]<br><b>Example:</b><br>Device(config-ext-nacl)# permit ip host 172.16.1.1 any ttl lt 2 | Sets conditions to allow a packet to pass a named IP access list. <ul style="list-style-type: none"> <li>• Every access list must have at least one <b>permit</b> statement.</li> <li>• This example permits packets from source 172.16.1.1 to any destination with a TTL value less than 2.</li> </ul> |
| <b>Step 5</b> | Continue to add <b>permit</b> or <b>deny</b> statements to achieve the filtering you want.                                                                                                                                                                                                                                                                                                                                         | --                                                                                                                                                                                                                                                                                                      |
| <b>Step 6</b> | <b>exit</b><br><b>Example:</b><br>Device(config-ext-nacl)# exit                                                                                                                                                                                                                                                                                                                                                                    | Exits any configuration mode to the next highest mode in the command-line interface (CLI) mode hierarchy.                                                                                                                                                                                               |
| <b>Step 7</b> | <b>interface</b> <i>type number</i><br><b>Example:</b><br>Device(config)# interface TenGigabitEthernet4/1/0                                                                                                                                                                                                                                                                                                                        | Configures an interface type and enters interface configuration mode.                                                                                                                                                                                                                                   |
| <b>Step 8</b> | <b>ip access-group</b> <i>access-list-name</i> { <b>in</b>   <b>out</b> }                                                                                                                                                                                                                                                                                                                                                          | Applies the access list to an interface.                                                                                                                                                                                                                                                                |



## Enabling Control Plane Policing to Filter on TTL Values 0 and 1

Perform this task to filter IP packets based on a TTL value of 0 or 1 and to protect the CPU from being overwhelmed. This task configures an access list for classification on TTL value 0 and 1, configures the Modular QoS Command-Line Interface (CLI) (MQC), and applies a policy map to the control plane. Any packets that pass the access list are dropped. This special access list is separate from any other interface access lists.

Because access lists are very flexible, it is not possible to define only one combination of **permit** and **deny** commands to filter packets based on the TTL value. This task illustrates just one example that achieves TTL filtering. Configure the appropriate **permit** and **deny** statements that will accomplish your filtering plan.

### SUMMARY STEPS

1. **enable**
2. **configure terminal**
3. **ip access-list extended** *access-list-name*
4. [*sequence-number*] **permit** *protocol source source-wildcard destination destination-wildcard ttl operator value*
5. Continue to add **permit** or **deny** statements to achieve the filtering you want.
6. **exit**
7. **class-map** *class-map-name* [**match-all** | **match-any**]
8. **match access-group** {*access-group* | **name** *access-group-name*}
9. **exit**
10. **policy-map** *policy-map-name*
11. **class** {*class-name* | **class-default**}
12. **drop**
13. **exit**
14. **exit**
15. **control-plane**
16. **service-policy** {**input** | **output**} *policy-map-name*

### DETAILED STEPS

|        | Command or Action                                                          | Purpose                                                                                                                                                            |
|--------|----------------------------------------------------------------------------|--------------------------------------------------------------------------------------------------------------------------------------------------------------------|
| Step 1 | <b>enable</b><br><b>Example:</b><br>Device> enable                         | Enables privileged EXEC mode. <ul style="list-style-type: none"> <li>• Enter your password if prompted.</li> </ul>                                                 |
| Step 2 | <b>configure terminal</b><br><b>Example:</b><br>Device# configure terminal | Enters global configuration mode.                                                                                                                                  |
| Step 3 | <b>ip access-list extended</b> <i>access-list-name</i><br><b>Example:</b>  | Defines an IP access list by name. <ul style="list-style-type: none"> <li>• An access list that filters on a TTL value must be an extended access list.</li> </ul> |

|                | Command or Action                                                                                                                                                                                                                          | Purpose                                                                                                                                                                                                                                                                                                        |
|----------------|--------------------------------------------------------------------------------------------------------------------------------------------------------------------------------------------------------------------------------------------|----------------------------------------------------------------------------------------------------------------------------------------------------------------------------------------------------------------------------------------------------------------------------------------------------------------|
|                | Device(config)# ip access-list extended ttlfilter                                                                                                                                                                                          |                                                                                                                                                                                                                                                                                                                |
| <b>Step 4</b>  | <p>[<i>sequence-number</i>] <b>permit</b> <i>protocol source source-wildcard destination destination-wildcard ttl operator</i> value</p> <p><b>Example:</b></p> <pre>Device(config-ext-nacl)# permit ip host 172.16.1.1 any ttl lt 2</pre> | <p>Sets conditions to allow a packet to pass a named IP access list.</p> <ul style="list-style-type: none"> <li>• Every access list must have at least one <b>permit</b> statement.</li> <li>• This example permits packets from source 172.16.1.1 to any destination with a TTL value less than 2.</li> </ul> |
| <b>Step 5</b>  | Continue to add <b>permit</b> or <b>deny</b> statements to achieve the filtering you want.                                                                                                                                                 | The packets that pass the access list will be dropped.                                                                                                                                                                                                                                                         |
| <b>Step 6</b>  | <p><b>exit</b></p> <p><b>Example:</b></p> <pre>Device(config-ext-nacl)# exit</pre>                                                                                                                                                         | Exits any configuration mode to the next highest mode in the CLI mode hierarchy.                                                                                                                                                                                                                               |
| <b>Step 7</b>  | <p><b>class-map</b> <i>class-map-name</i> [<b>match-all</b>   <b>match-any</b>]</p> <p><b>Example:</b></p> <pre>Device(config)# class-map acl-filtering</pre>                                                                              | Creates a class map to be used for matching packets to a specified class.                                                                                                                                                                                                                                      |
| <b>Step 8</b>  | <p><b>match access-group</b> {<i>access-group</i>   <b>name</b> <i>access-group-name</i>}</p> <p><b>Example:</b></p> <pre>Device(config-cmap)# match access-group name ttlfilter</pre>                                                     | Configures the match criteria for a class map on the basis of the specified access control list.                                                                                                                                                                                                               |
| <b>Step 9</b>  | <p><b>exit</b></p> <p><b>Example:</b></p> <pre>Device(config-cmap)# exit</pre>                                                                                                                                                             | Exits any configuration mode to the next highest mode in the CLI mode hierarchy.                                                                                                                                                                                                                               |
| <b>Step 10</b> | <p><b>policy-map</b> <i>policy-map-name</i></p> <p><b>Example:</b></p> <pre>Device(config)# policy-map acl-filter</pre>                                                                                                                    | Creates or modifies a policy map that can be attached to one or more interface to specify a service policy.                                                                                                                                                                                                    |
| <b>Step 11</b> | <p><b>class</b> {<i>class-name</i>   <b>class-default</b>}</p> <p><b>Example:</b></p> <pre>Device(config-pmap)# class acl-filter-class</pre>                                                                                               | Specifies the name of the class whose policy you want to create or change or to specify the default class (commonly known as the class-default class) before you configure its policy.                                                                                                                         |
| <b>Step 12</b> | <p><b>drop</b></p> <p><b>Example:</b></p>                                                                                                                                                                                                  | Configures a traffic class to discard packets belonging to a specific class.                                                                                                                                                                                                                                   |

|                | Command or Action                                                                                                               | Purpose                                                                                                   |
|----------------|---------------------------------------------------------------------------------------------------------------------------------|-----------------------------------------------------------------------------------------------------------|
|                | Device(config-pmap-c)# drop                                                                                                     |                                                                                                           |
| <b>Step 13</b> | <b>exit</b><br><b>Example:</b><br>Device(config-pmap-c)# exit                                                                   | Exits any configuration mode to the next highest mode in the CLI mode hierarchy.                          |
| <b>Step 14</b> | <b>exit</b><br><b>Example:</b><br>Device(config-pmap)# exit                                                                     | Exits any configuration mode to the next highest mode in the CLI mode hierarchy.                          |
| <b>Step 15</b> | <b>control-plane</b><br><b>Example:</b><br>Device(config)# control-plane                                                        | Associates or modifies attributes or parameters that are associated with the control plane of the device. |
| <b>Step 16</b> | <b>service-policy {input   output} policy-map-name</b><br><b>Example:</b><br>Device(config-cp)# service-policy input acl-filter | Attaches a policy map to a control plane for aggregate control plane services.                            |

## Configuration Examples for Filtering IP Options, TCP Flags, Noncontiguous Ports

### Example: Filtering Packets That Contain IP Options

The following example shows an extended access list named mylist2 that contains access list entries (ACEs) that are configured to permit TCP packets only if they contain the IP Options that are specified in the ACEs:

```
ip access-list extended mylist2
 10 permit ip any any option eool
 20 permit ip any any option record-route
 30 permit ip any any option zsu
 40 permit ip any any option mtup
```

The **show access-list** command has been entered to show how many packets were matched and therefore permitted:

```
Device# show ip access-list mylist2
Extended IP access list test
10 permit ip any any option eool (1 match)
20 permit ip any any option record-route (1 match)
30 permit ip any any option zsu (1 match)
40 permit ip any any option mtup (1 match)
```

## Example: Filtering Packets That Contain TCP Flags

The following access list allows TCP packets only if the TCP flags ACK and SYN are set and the FIN flag is not set:

```
ip access-list extended aaa
 permit tcp any any match-all +ack +syn -fin
 end
```

The **show access-list** command has been entered to display the ACL:

```
Device# show access-list aaa

Extended IP access list aaa
 10 permit tcp any any match-all +ack +syn -fin
```

## Example: Creating an Access List Entry with Noncontiguous Ports

The following access list entry can be created because up to ten ports can be entered after the **eq** and **neq** operators:

```
ip access-list extended aaa
 permit tcp any eq telnet ftp any eq 23 45 34
 end
```

Enter the **show access-lists** command to display the newly created access list entry.

```
Device# show access-lists aaa

Extended IP access list aaa
 10 permit tcp any eq telnet ftp any eq 23 45 34
```

## Example: Consolidating Some Existing Access List Entries into One Access List Entry with Noncontiguous Ports

The **show access-lists** command is used to display a group of access list entries for the access list named abc:

```
Device# show access-lists abc

Extended IP access list abc
 10 permit tcp any eq telnet any eq 450
 20 permit tcp any eq telnet any eq 679
 30 permit tcp any eq ftp any eq 450
 40 permit tcp any eq ftp any eq 679
```

Because the entries are all for the same **permit** statement and simply show different ports, they can be consolidated into one new access list entry. The following example shows the removal of the redundant access list entries and the creation of a new access list entry that consolidates the previously displayed group of access list entries:

```
ip access-list extended abc
 no 10
 no 20
 no 30
 no 40
```

```
permit tcp any eq telnet ftp any eq 450 679
end
```

When the **show access-lists** command is reentered, the consolidated access list entry is displayed:

```
Device# show access-lists abc
Extended IP access list abc
 10 permit tcp any eq telnet ftp any eq 450 679
```

## Example: Filtering on TTL Value

The following access list filters IP packets containing type of service (ToS) level 3 with time-to-live (TTL) values 10 and 20. It also filters IP packets with a TTL greater than 154 and applies that rule to noninitial fragments. It permits IP packets with a precedence level of flash and a TTL value not equal to 1, and it sends log messages about such packets to the console. All other packets are denied.

```
ip access-list extended incomingfilter
deny ip any any tos 3 ttl eq 10 20
deny ip any any ttl gt 154 fragments
permit ip any any precedence flash ttl neq 1 log
!
interface TenGigabitEthernet4/1/0

ip access-group incomingfilter in
```

## Example: Control Plane Policing to Filter on TTL Values 0 and 1

The following example configures a traffic class called `acl-filter-class` for use in a policy map called `acl-filter`. An access list permits IP packets from any source having a time-to-live (TTL) value of 0 or 1. Any packets matching the access list are dropped. The policy map is attached to the control plane.

```
ip access-list extended ttlfilter

permit ip any any ttl eq 0 1

class-map acl-filter-class

match access-group name ttlfilter

policy-map acl-filter

class acl-filter-class

drop

control-plane

service-policy input acl-filter
```

# Additional References

## Related Documents

| Related Topic                                                                                                     | Document Title                                                    |
|-------------------------------------------------------------------------------------------------------------------|-------------------------------------------------------------------|
| Security commands                                                                                                 | <i>Cisco IOS Security Command Reference</i>                       |
| Configuring the device to drop or ignore packets containing IP Options by using the <b>no ip options</b> command. | <i>ACL IP Options Selective Drop</i>                              |
| Overview information about access lists.                                                                          | <i>IP Access List Overview</i>                                    |
| Information about creating an IP access list and applying it to an interface                                      | <i>Creating an IP Access List and Applying It to an Interface</i> |
| QoS commands                                                                                                      | <i>Cisco IOS Quality of Service Solutions Command Reference</i>   |

## RFCs

| RFC      | Title                                                                                                               |
|----------|---------------------------------------------------------------------------------------------------------------------|
| RFC 791  | <i>Internet Protocol</i><br><a href="http://www.faqs.org/rfcs/rfc791.html">http://www.faqs.org/rfcs/rfc791.html</a> |
| RFC 793  | <i>Transmission Control Protocol</i>                                                                                |
| RFC 1393 | <i>Traceroute Using an IP Option</i>                                                                                |

## Technical Assistance

| Description                                                                                                                                                                                                                                                                                                                                                                           | Link                                                                                                              |
|---------------------------------------------------------------------------------------------------------------------------------------------------------------------------------------------------------------------------------------------------------------------------------------------------------------------------------------------------------------------------------------|-------------------------------------------------------------------------------------------------------------------|
| The Cisco Support and Documentation website provides online resources to download documentation, software, and tools. Use these resources to install and configure the software and to troubleshoot and resolve technical issues with Cisco products and technologies. Access to most tools on the Cisco Support and Documentation website requires a Cisco.com user ID and password. | <a href="http://www.cisco.com/cisco/web/support/index.html">http://www.cisco.com/cisco/web/support/index.html</a> |

# Feature Information for Creating an IP Access List to Filter IP Options, TCP Flags, Noncontiguous Ports, or TTL Values

Use Cisco Feature Navigator to find information about the platform support and software image support. Cisco Feature Navigator enables you to determine which software images support a specific software release, feature set, or platform. To access Cisco Feature Navigator, go to the <https://cfng.cisco.com/> link. An account on the Cisco.com page is not required.



**Note** The following table lists the software release in which a given feature is introduced. Unless noted otherwise, subsequent releases of that software release train also support that feature.

*Table 243: Feature Information for Creating an IP Access List to Filter IP Options, TCP Flags, Noncontiguous Ports, or TTL Values*

| Feature Name    | Releases                 | Feature Information                                                                                            |
|-----------------|--------------------------|----------------------------------------------------------------------------------------------------------------|
| IP access lists | Cisco IOS XE Fuji 16.7.1 | This feature was integrated into Cisco IOS XE Fuji 16.7.1 on the Cisco cBR Series Converged Broadband Routers. |







## CHAPTER 71

# Refining an IP Access List

---

There are several ways to refine an access list while or after you create it. You can change the order of the entries in an access list or add entries to an access list. You can restrict access list entries to a certain time of day or week, or achieve finer granularity when filtering packets by filtering noninitial fragments of packets.

Your software release may not support all the features that are documented in this module. For the latest feature information and caveats, see the release notes for your platform and software release. The Feature Information Table at the end of this document provides information about the documented features and lists the releases in which each feature is supported.

Use Cisco Feature Navigator to find information about platform support and Cisco software image support. To access Cisco Feature Navigator, go to <http://tools.cisco.com/ITDIT/CFN/>. An account on <http://www.cisco.com/> is not required.

### Contents

- [Hardware Compatibility Matrix for the Cisco cBR Series Routers, on page 1181](#)
- [Information About Refining an IP Access List, on page 1183](#)
- [How to Refine an IP Access List, on page 1186](#)
- [Configuration Examples for Refining an IP Access List, on page 1191](#)
- [Additional References, on page 1193](#)
- [Feature Information for Refining an IP Access List, on page 1194](#)

## Hardware Compatibility Matrix for the Cisco cBR Series Routers



---

**Note** The hardware components that are introduced in a given Cisco IOS-XE Release are supported in all subsequent releases unless otherwise specified.

---

Table 244: Hardware Compatibility Matrix for the Cisco cBR Series Routers

| Cisco CMTS Platform                    | Processor Engine                                                                                                                                                                                  | Interface Cards                                                                                                                                                                                                                                                                                                                                                                                                                                                                                                                                                                                                                                                                                                                                                                                 |
|----------------------------------------|---------------------------------------------------------------------------------------------------------------------------------------------------------------------------------------------------|-------------------------------------------------------------------------------------------------------------------------------------------------------------------------------------------------------------------------------------------------------------------------------------------------------------------------------------------------------------------------------------------------------------------------------------------------------------------------------------------------------------------------------------------------------------------------------------------------------------------------------------------------------------------------------------------------------------------------------------------------------------------------------------------------|
| Cisco cBR-8 Converged Broadband Router | <p><b>Cisco IOS-XE Release 16.5.1 and Later Releases</b></p> <p>Cisco cBR-8 Supervisor:</p> <ul style="list-style-type: none"> <li>• PID—CBR-SUP-250G</li> <li>• PID—CBR-CCAP-SUP-160G</li> </ul> | <p><b>Cisco IOS-XE Release 16.5.1 and Later Releases</b></p> <p>Cisco cBR-8 CCAP Line Cards:</p> <ul style="list-style-type: none"> <li>• PID—CBR-LC-8D30-16U30</li> <li>• PID—CBR-LC-8D31-16U30</li> <li>• PID—CBR-RF-PIC</li> <li>• PID—CBR-RF-PROT-PIC</li> <li>• PID—CBR-CCAP-LC-40G</li> <li>• PID—CBR-CCAP-LC-40G-R</li> <li>• PID—CBR-CCAP-LC-G2-R</li> <li>• PID—CBR-SUP-8X10G-PIC</li> <li>• PID—CBR-2X100G-PIC</li> </ul> <p>Digital PICs:</p> <ul style="list-style-type: none"> <li>• PID—CBR-DPIC-8X10G</li> <li>• PID—CBR-DPIC-2X100G</li> </ul> <p>Cisco cBR-8 Downstream PHY Module:</p> <ul style="list-style-type: none"> <li>• PID—CBR-D31-DS-MOD</li> </ul> <p>Cisco cBR-8 Upstream PHY Modules:</p> <ul style="list-style-type: none"> <li>• PID—CBR-D31-US-MOD</li> </ul> |



**Note** Do not use DPICs (8X10G and 2x100G) to forward IP traffic, as it may cause buffer exhaustion, leading to line card reload.

The only allowed traffic on a DPIC interface is DEPI, UEPI, and GCP traffic from the Cisco cBR-8 router to Remote PHY devices. Other traffic such as DHCP, SSH, and UTSC should flow via another router, since DPICs cannot be used for normal routing.

# Information About Refining an IP Access List

## Access List Sequence Numbers

The ability to apply sequence numbers to IP access list entries simplifies access list changes. Prior to the IP Access List Entry Sequence Numbering feature, there was no way to specify the position of an entry within an access list. If you wanted to insert an entry in the middle of an existing list, all of the entries after the desired position had to be removed, then the new entry was added, and then all the removed entries had to be reentered. This method was cumbersome and error prone.

Sequence numbers allow users to add access list entries and resequence them. When you add a new entry, you specify the sequence number so that it is in a desired position in the access list. If necessary, entries currently in the access list can be resequenced to create room to insert the new entry.

## Benefits of Access List Sequence Numbers

An access list sequence number is a number at the beginning of a **permit** or **deny** command in an access list. The sequence number determines the order that the entry appears in the access list. The ability to apply sequence numbers to IP access list entries simplifies access list changes.

Prior to having sequence numbers, users could only add access list entries to the end of an access list; therefore, needing to add statements anywhere except the end of the list required reconfiguring the entire access list. There was no way to specify the position of an entry within an access list. If a user wanted to insert an entry (statement) in the middle of an existing list, all of the entries after the desired position had to be removed, then the new entry was added, and then all the removed entries had to be reentered. This method was cumbersome and error prone.

This feature allows users to add sequence numbers to access list entries and resequence them. When a user adds a new entry, the user chooses the sequence number so that it is in a desired position in the access list. If necessary, entries currently in the access list can be resequenced to create room to insert the new entry. Sequence numbers make revising an access list much easier.

## Sequence Numbering Behavior

- For backward compatibility with previous releases, if entries with no sequence numbers are applied, the first entry is assigned a sequence number of 10, and successive entries are incremented by 10. The maximum sequence number is 2147483647. If the generated sequence number exceeds this maximum number, the following message is displayed:

```
Exceeded maximum sequence number.
```

- If the user enters an entry without a sequence number, it is assigned a sequence number that is 10 greater than the last sequence number in that access list and is placed at the end of the list.
- If the user enters an entry that matches an already existing entry (except for the sequence number), then no changes are made.
- If the user enters a sequence number that is already present, the following error message is generated:

Duplicate sequence number.

- If a new access list is entered from global configuration mode, then sequence numbers for that access list are generated automatically.
- Sequence numbers are not nvgened. That is, the sequence numbers themselves are not saved. In the event that the system is reloaded, the configured sequence numbers revert to the default sequence starting number and increment. The function is provided for backward compatibility with software releases that do not support sequence numbering.
- This feature works with named and numbered, standard and extended IP access lists.

## Benefits of Time Ranges

Benefits and possible uses of time ranges include the following:

- The network administrator has more control over permitting or denying a user access to resources. These resources could be an application (identified by an IP address/mask pair and a port number), policy routing, or an on-demand link (identified as interesting traffic to the dialer).
- Network administrators can set time-based security policy, including the following:
  - Perimeter security using access lists
  - Data confidentiality with IP Security Protocol (IPsec)
- When provider access rates vary by time of day, it is possible to automatically reroute traffic cost effectively.
- Network administrators can control logging messages. Access list entries can log traffic at certain times of the day, but not constantly. Therefore, administrators can simply deny access without needing to analyze many logs generated during peak hours.

## Benefits Filtering Noninitial Fragments of Packets

Filter noninitial fragments of packets with an extended access list if you want to block more of the traffic you intended to block, not just the initial fragment of such packets. You should first understand the following concepts.

If the **fragments** keyword is used in additional IP access list entries that deny fragments, the fragment control feature provides the following benefits:

### Additional Security

You are able to block more of the traffic you intended to block, not just the initial fragment of such packets. The unwanted fragments no longer linger at the receiver until the reassembly timeout is reached because they are blocked before being sent to the receiver. Blocking a greater portion of unwanted traffic improves security and reduces the risk from potential hackers.

### Reduced Cost

By blocking unwanted noninitial fragments of packets, you are not paying for traffic you intended to block.

### Reduced Storage

By blocking unwanted noninitial fragments of packets from ever reaching the receiver, that destination does not have to store the fragments until the reassembly timeout period is reached.

### Expected Behavior Is Achieved

The noninitial fragments will be handled in the same way as the initial fragment, which is what you would expect. There are fewer unexpected policy routing results and fewer fragments of packets being routed when they should not be.

## Access List Processing of Fragments

The behavior of access list entries regarding the use or lack of use of the **fragments** keyword can be summarized as follows:

| If the Access-List Entry Has...                                                                                     | Then...                                                                                                                                                                                                                                                                                                                                                                                                                                                                                                                                                                                                                                                                                                                                                                                                                                                                                                                                                                                                                                                                                                                                                                                                                                                                                                                                                                    |
|---------------------------------------------------------------------------------------------------------------------|----------------------------------------------------------------------------------------------------------------------------------------------------------------------------------------------------------------------------------------------------------------------------------------------------------------------------------------------------------------------------------------------------------------------------------------------------------------------------------------------------------------------------------------------------------------------------------------------------------------------------------------------------------------------------------------------------------------------------------------------------------------------------------------------------------------------------------------------------------------------------------------------------------------------------------------------------------------------------------------------------------------------------------------------------------------------------------------------------------------------------------------------------------------------------------------------------------------------------------------------------------------------------------------------------------------------------------------------------------------------------|
| <p>...no <b>fragments</b> keyword (the default), and assuming all of the access-list entry information matches,</p> | <p>For an access list entry that contains only Layer 3 information:</p> <ul style="list-style-type: none"> <li>• The entry is applied to nonfragmented packets, initial fragments, and noninitial fragments.</li> </ul> <p>For an access list entry that contains Layer 3 and Layer 4 information:</p> <ul style="list-style-type: none"> <li>• The entry is applied to nonfragmented packets and initial fragments.               <ul style="list-style-type: none"> <li>• If the entry is a <b>permit</b> statement, then the packet or fragment is permitted.</li> <li>• If the entry is a <b>deny</b> statement, then the packet or fragment is denied.</li> </ul> </li> <li>• The entry is also applied to noninitial fragments in the following manner. Because noninitial fragments contain only Layer 3 information, only the Layer 3 portion of an access list entry can be applied. If the Layer 3 portion of the access list entry matches, and               <ul style="list-style-type: none"> <li>• If the entry is a <b>permit</b> statement, then the noninitial fragment is permitted.</li> <li>• If the entry is a <b>deny</b> statement, then the next access list entry is processed.</li> </ul> </li> </ul> <p><b>Note</b> The <b>deny</b> statements are handled differently for noninitial fragments versus nonfragmented or initial fragments.</p> |
| <p>...the <b>fragments</b> keyword, and assuming all of the access-list entry information matches,</p>              | <p>The access list entry is applied only to noninitial fragments.</p> <p>The <b>fragments</b> keyword cannot be configured for an access list entry that contains any Layer 4 information.</p>                                                                                                                                                                                                                                                                                                                                                                                                                                                                                                                                                                                                                                                                                                                                                                                                                                                                                                                                                                                                                                                                                                                                                                             |

Be aware that you should not add the **fragments** keyword to every access list entry because the first fragment of the IP packet is considered a nonfragment and is treated independently of the subsequent fragments. An initial fragment will not match an access list **permit** or **deny** entry that contains the **fragments** keyword. The packet is compared to the next access list entry, and so on, until it is either permitted or denied by an access

list entry that does not contain the **fragments** keyword. Therefore, you may need two access list entries for every **deny** entry. The first **deny** entry of the pair will not include the **fragments** keyword and applies to the initial fragment. The second **deny** entry of the pair will include the **fragments** keyword and applies to the subsequent fragments. In the cases in which there are multiple **deny** entries for the same host but with different Layer 4 ports, a single **deny** access list entry with the **fragments** keyword for that host is all that needs to be added. Thus all the fragments of a packet are handled in the same manner by the access list.

Packet fragments of IP datagrams are considered individual packets, and each counts individually as a packet in access list accounting and access list violation counts.

## How to Refine an IP Access List

The tasks in this module provide you with various ways to refine an access list if you did not already do so while you were creating it. You can change the order of the entries in an access list, add entries to an access list, restrict access list entries to a certain time of day or week, or achieve finer granularity when filtering packets by filtering on noninitial fragments of packets.

### Revising an Access List Using Sequence Numbers

Perform this task if you want to add entries to an existing access list, change the order of entries, or simply number the entries in an access list to accommodate future changes.



**Note** Remember that if you want to delete an entry from an access list, you can simply use the **no deny** or **no permit** form of the command, or the **no sequence-number** command if the statement already has a sequence number.



**Note** • Access list sequence numbers do not support dynamic, reflexive, or firewall access lists.

#### SUMMARY STEPS

1. **enable**
2. **configure terminal**
3. **ip access-list resequence** *access-list-name starting-sequence-number increment*
4. **ip access-list** {**standard**|**extended**} *access-list-name*
5. Do one of the following:
  - *sequence-number* **permit** *source source-wildcard*
  - *sequence-number* **permit** *protocol source source-wildcard destination destination-wildcard* [**precedence** *precedence*][**tos** *tos*] [**log**] [**time-range** *time-range-name*] [**fragments**]
6. Do one of the following:
  - *sequence-number* **deny** *source source-wildcard*
  - *sequence-number* **deny** *protocol source source-wildcard destination destination-wildcard* [**precedence** *precedence*][**tos** *tos*] [**log**] [**time-range** *time-range-name*] [**fragments**]

7. Repeat Step 5 and Step 6 as necessary, adding statements by sequence number where you planned. Use the **no sequence-number** command to delete an entry.
8. **end**
9. **show ip access-lists** *access-list-name*

## DETAILED STEPS

|               | Command or Action                                                                                                                                                                                                                                                                                                                                                                                                                                                                                                                       | Purpose                                                                                                                                                                                                                                                                                                                                                                                                                                                                                                                                                                                                                                                            |
|---------------|-----------------------------------------------------------------------------------------------------------------------------------------------------------------------------------------------------------------------------------------------------------------------------------------------------------------------------------------------------------------------------------------------------------------------------------------------------------------------------------------------------------------------------------------|--------------------------------------------------------------------------------------------------------------------------------------------------------------------------------------------------------------------------------------------------------------------------------------------------------------------------------------------------------------------------------------------------------------------------------------------------------------------------------------------------------------------------------------------------------------------------------------------------------------------------------------------------------------------|
| <b>Step 1</b> | <b>enable</b><br><b>Example:</b><br><pre>Router&gt; enable</pre>                                                                                                                                                                                                                                                                                                                                                                                                                                                                        | Enables privileged EXEC mode. <ul style="list-style-type: none"> <li>• Enter your password if prompted.</li> </ul>                                                                                                                                                                                                                                                                                                                                                                                                                                                                                                                                                 |
| <b>Step 2</b> | <b>configure terminal</b><br><b>Example:</b><br><pre>Router# configure terminal</pre>                                                                                                                                                                                                                                                                                                                                                                                                                                                   | Enters global configuration mode.                                                                                                                                                                                                                                                                                                                                                                                                                                                                                                                                                                                                                                  |
| <b>Step 3</b> | <b>ip access-list resequence</b> <i>access-list-name</i> <i>starting-sequence-number</i> <i>increment</i><br><b>Example:</b><br><pre>Router(config)# ip access-list resequence kmd1 100 15</pre>                                                                                                                                                                                                                                                                                                                                        | Resequences the specified IP access list using the starting sequence number and the increment of sequence numbers. <ul style="list-style-type: none"> <li>• This example resequences an access list named kmd1. The starting sequence number is 100 and the increment is 15.</li> </ul>                                                                                                                                                                                                                                                                                                                                                                            |
| <b>Step 4</b> | <b>ip access-list</b> { <b>standard</b>   <b>extended</b> } <i>access-list-name</i><br><b>Example:</b><br><pre>Router(config)# ip access-list standard xyz123</pre>                                                                                                                                                                                                                                                                                                                                                                     | Specifies the IP access list by name and enters named access list configuration mode. <ul style="list-style-type: none"> <li>• If you specify <b>standard</b>, make sure you specify subsequent <b>permit</b> and <b>deny</b> statements using the standard access list syntax.</li> <li>• If you specify <b>extended</b>, make sure you specify subsequent <b>permit</b> and <b>deny</b> statements using the extended access list syntax.</li> </ul>                                                                                                                                                                                                             |
| <b>Step 5</b> | Do one of the following: <ul style="list-style-type: none"> <li>• <i>sequence-number</i> <b>permit</b> <i>source</i> <i>source-wildcard</i></li> <li>• <i>sequence-number</i> <b>permit</b> <i>protocol</i> <i>source</i> <i>source-wildcard</i> <i>destination</i> <i>destination-wildcard</i> [<b>precedence</b> <i>precedence</i>][<b>tos</b> <i>tos</i>] [<b>log</b>] [<b>time-range</b> <i>time-range-name</i>] [<b>fragments</b>]</li> </ul> <b>Example:</b><br><pre>Router(config-std-nacl)# 105 permit 10.5.5.5 0.0.0.255</pre> | Specifies a permit statement in named IP access list mode. <ul style="list-style-type: none"> <li>• This access list happens to use a <b>permit</b> statement first, but a <b>deny</b> statement could appear first, depending on the order of statements you need.</li> <li>• See the <b>permit</b> (IP) command for additional command syntax to permit upper layer protocols (ICMP, IGMP, TCP, and UDP).</li> <li>• Use the <b>no sequence-number</b> command to delete an entry.</li> <li>• As the prompt indicates, this access list was a standard access list. If you had specified <b>extended</b> in Step 4, the prompt for this step would be</li> </ul> |

|               | Command or Action                                                                                                                                                                                                                                                                                                                                                                                                 | Purpose                                                                                                                                                                                                                                                                                                                                                                                                                                                                                                                                                                                                                                                                                                                                                      |
|---------------|-------------------------------------------------------------------------------------------------------------------------------------------------------------------------------------------------------------------------------------------------------------------------------------------------------------------------------------------------------------------------------------------------------------------|--------------------------------------------------------------------------------------------------------------------------------------------------------------------------------------------------------------------------------------------------------------------------------------------------------------------------------------------------------------------------------------------------------------------------------------------------------------------------------------------------------------------------------------------------------------------------------------------------------------------------------------------------------------------------------------------------------------------------------------------------------------|
|               |                                                                                                                                                                                                                                                                                                                                                                                                                   | Router(config-ext-nacl)# and you would use the extended <b>permit</b> command syntax.                                                                                                                                                                                                                                                                                                                                                                                                                                                                                                                                                                                                                                                                        |
| <b>Step 6</b> | <p>Do one of the following:</p> <ul style="list-style-type: none"> <li><i>sequence-number deny source source-wildcard</i></li> <li><i>sequence-number deny protocol source source-wildcard destination destination-wildcard [precedence precedence][tos tos] [log] [time-range time-range-name] [fragments]</i></li> </ul> <p><b>Example:</b></p> <pre>Router(config-std-nacl)# 110 deny 10.6.6.7 0.0.0.255</pre> | <p>(Optional) Specifies a deny statement in named IP access list mode.</p> <ul style="list-style-type: none"> <li>This access list happens to use a <b>permit</b> statement first, but a <b>deny</b> statement could appear first, depending on the order of statements you need.</li> <li>See the <b>deny</b> (IP) command for additional command syntax to permit upper layer protocols (ICMP, IGMP, TCP, and UDP).</li> <li>Use the <b>no sequence-number</b> command to delete an entry.</li> <li>As the prompt indicates, this access list was a standard access list. If you had specified <b>extended</b> in Step 4, the prompt for this step would be Router(config-ext-nacl)# and you would use the extended <b>deny</b> command syntax.</li> </ul> |
| <b>Step 7</b> | Repeat Step 5 and Step 6 as necessary, adding statements by sequence number where you planned. Use the <b>no sequence-number</b> command to delete an entry.                                                                                                                                                                                                                                                      | Allows you to revise the access list.                                                                                                                                                                                                                                                                                                                                                                                                                                                                                                                                                                                                                                                                                                                        |
| <b>Step 8</b> | <p><b>end</b></p> <p><b>Example:</b></p> <pre>Router(config-std-nacl)# end</pre>                                                                                                                                                                                                                                                                                                                                  | (Optional) Exits the configuration mode and returns to privileged EXEC mode.                                                                                                                                                                                                                                                                                                                                                                                                                                                                                                                                                                                                                                                                                 |
| <b>Step 9</b> | <p><b>show ip access-lists access-list-name</b></p> <p><b>Example:</b></p> <pre>Router# show ip access-lists xyz123</pre>                                                                                                                                                                                                                                                                                         | <p>(Optional) Displays the contents of the IP access list.</p> <ul style="list-style-type: none"> <li>Review the output to see that the access list includes the new entry.</li> </ul>                                                                                                                                                                                                                                                                                                                                                                                                                                                                                                                                                                       |

## Examples

The following is sample output from the **show ip access-lists** command when the **xyz123** access list is specified.

```
Router# show ip access-lists xyz123
Standard IP access list xyz123
100 permit 10.4.4.0, wildcard bits 0.0.0.255
105 permit 10.5.5.5, wildcard bits 0.0.0.255
115 permit 10.0.0.0, wildcard bits 0.0.0.255
130 permit 10.5.5.0, wildcard bits 0.0.0.255
145 permit 10.0.0.0, wildcard bits 0.0.0.255
```



## Restricting an Access List Entry to a Time of Day or Week

By default, access list statements are always in effect once they are applied. However, you can define the times of the day or week that **permit** or **deny** statements are in effect by defining a time range, and then referencing the time range by name in an individual access list statement. IP and Internetwork Packet Exchange (IPX) named or numbered extended access lists can use time ranges.

### SUMMARY STEPS

1. **enable**
2. **configure terminal**
3. **ip access-list extended** *name*
4. [*sequence-number*] **deny** *protocol source[source-wildcard] [operator port[port]] destination[destination-wildcard] [operator port[port]]*
5. [*sequence-number*] **deny** *protocol source[source-wildcard][operator port[port]] destination[destination-wildcard] [operator port[port]] fragments*
6. [*sequence-number*] **permit** *protocol source[source-wildcard] [operator port[port]] destination[destination-wildcard] [operator port[port]]*
7. Repeat some combination of Steps 4 through 6 until you have specified the values on which you want to base your access list.
8. **end**
9. **show ip access-list**

### DETAILED STEPS

|        | Command or Action                                                                                                                                                                                                                      | Purpose                                                                                                                                                                        |
|--------|----------------------------------------------------------------------------------------------------------------------------------------------------------------------------------------------------------------------------------------|--------------------------------------------------------------------------------------------------------------------------------------------------------------------------------|
| Step 1 | <b>enable</b><br><b>Example:</b><br><br>Router> enable                                                                                                                                                                                 | Enables privileged EXEC mode.<br><br>• Enter your password if prompted.                                                                                                        |
| Step 2 | <b>configure terminal</b><br><b>Example:</b><br><br>Router# configure terminal                                                                                                                                                         | Enters global configuration mode.                                                                                                                                              |
| Step 3 | <b>ip access-list extended</b> <i>name</i><br><b>Example:</b><br><br>Router(config)# ip access-list extended rstrct4                                                                                                                   | Defines an extended IP access list using a name and enters extended named access list configuration mode.                                                                      |
| Step 4 | [ <i>sequence-number</i> ] <b>deny</b> <i>protocol source[source-wildcard] [operator port[port]] destination[destination-wildcard] [operator port[port]]</i><br><b>Example:</b><br><br>Router(config-ext-nacl)# deny ip any 172.20.1.1 | (Optional) Denies any packet that matches all of the conditions specified in the statement.<br><br>• This statement will apply to nonfragmented packets and initial fragments. |

|               | Command or Action                                                                                                                                                                                                                                                                                                                                    | Purpose                                                                                                                                                                                                                                                                                                                                                                                                                                                                                                                                                                                                                         |
|---------------|------------------------------------------------------------------------------------------------------------------------------------------------------------------------------------------------------------------------------------------------------------------------------------------------------------------------------------------------------|---------------------------------------------------------------------------------------------------------------------------------------------------------------------------------------------------------------------------------------------------------------------------------------------------------------------------------------------------------------------------------------------------------------------------------------------------------------------------------------------------------------------------------------------------------------------------------------------------------------------------------|
| <b>Step 5</b> | <p>[<i>sequence-number</i>] <b>deny</b> <i>protocol</i><br/> <i>source</i>[<i>source-wildcard</i>][<i>operator port</i>[<i>port</i>]]<br/> <i>destination</i>[<i>destination-wildcard</i>] [<i>operator port</i>[<i>port</i>]]<br/> <b>fragments</b></p> <p><b>Example:</b></p> <pre>Router(config-ext-nacl)# deny ip any 172.20.1.1 fragments</pre> | <p>(Optional) Denies any packet that matches all of the conditions specified in the statement</p> <ul style="list-style-type: none"> <li>This statement will apply to noninitial fragments.</li> </ul>                                                                                                                                                                                                                                                                                                                                                                                                                          |
| <b>Step 6</b> | <p>[<i>sequence-number</i>] <b>permit</b> <i>protocol</i><br/> <i>source</i>[<i>source-wildcard</i>] [<i>operator port</i>[<i>port</i>]]<br/> <i>destination</i>[<i>destination-wildcard</i>] [<i>operator port</i>[<i>port</i>]]</p> <p><b>Example:</b></p> <pre>Router(config-ext-nacl)# permit tcp any any</pre>                                  | <p>Permits any packet that matches all of the conditions specified in the statement.</p> <ul style="list-style-type: none"> <li>Every access list needs at least one <b>permit</b> statement.</li> <li>If the <i>source-wildcard</i> or <i>destination-wildcard</i> is omitted, a wildcard mask of 0.0.0.0 is assumed, meaning match on all bits of the source or destination address, respectively.</li> <li>Optionally use the keyword <b>any</b> as a substitute for the <i>source source-wildcard</i> or <i>destination destination-wildcard</i> to specify the address and wildcard of 0.0.0.0 255.255.255.255.</li> </ul> |
| <b>Step 7</b> | Repeat some combination of Steps 4 through 6 until you have specified the values on which you want to base your access list.                                                                                                                                                                                                                         | Remember that all sources not specifically permitted are denied by an implicit <b>deny</b> statement at the end of the access list.                                                                                                                                                                                                                                                                                                                                                                                                                                                                                             |
| <b>Step 8</b> | <p><b>end</b></p> <p><b>Example:</b></p> <pre>Router(config-ext-nacl)# end</pre>                                                                                                                                                                                                                                                                     | Ends configuration mode and returns the system to privileged EXEC mode.                                                                                                                                                                                                                                                                                                                                                                                                                                                                                                                                                         |
| <b>Step 9</b> | <p><b>show ip access-list</b></p> <p><b>Example:</b></p> <pre>Router# show ip access-list</pre>                                                                                                                                                                                                                                                      | (Optional) Displays the contents of all current IP access lists.                                                                                                                                                                                                                                                                                                                                                                                                                                                                                                                                                                |

## What to Do Next

Apply the access list to an interface or reference it from a command that accepts an access list.



**Note** To effectively eliminate all packets that contain IP Options, we recommend that you configure the global **ip options drop** command.

# Configuration Examples for Refining an IP Access List

## Example Resequencing Entries in an Access List

The following example shows an access list before and after resequencing. The starting value is 1, and increment value is 2. The subsequent entries are ordered based on the increment values that users provide, and the range is from 1 to 2147483647.

When an entry with no sequence number is entered, by default it has a sequence number of 10 more than the last entry in the access list.

```
Router# show access-list carls
Extended IP access list carls
 10 permit ip host 10.3.3.3 host 172.16.5.34
 20 permit icmp any any
 30 permit tcp any host 10.3.3.3
 40 permit ip host 10.4.4.4 any
 50 Dynamic test permit ip any any
 60 permit ip host 172.16.2.2 host 10.3.3.12
 70 permit ip host 10.3.3.3 any log
 80 permit tcp host 10.3.3.3 host 10.1.2.2
 90 permit ip host 10.3.3.3 any
100 permit ip any any
Router(config)# ip access-list extended carls
Router(config)# ip access-list resequence carls 1 2
Router(config)# end
Router# show access-list carls
Extended IP access list carls
 1 permit ip host 10.3.3.3 host 172.16.5.34
 3 permit icmp any any
 5 permit tcp any host 10.3.3.3
 7 permit ip host 10.4.4.4 any
 9 Dynamic test permit ip any any
11 permit ip host 172.16.2.2 host 10.3.3.12
13 permit ip host 10.3.3.3 any log
15 permit tcp host 10.3.3.3 host 10.1.2.2
17 permit ip host 10.3.3.3 any
19 permit ip any any
```

## Example Adding an Entry with a Sequence Number

In the following example, a new entry (sequence number 15) is added to an access list:

```
Router# show ip access-list
Standard IP access list tryon
 2 permit 10.4.4.2, wildcard bits 0.0.255.255
 5 permit 10.0.0.44, wildcard bits 0.0.0.255
10 permit 10.0.0.1, wildcard bits 0.0.0.255
20 permit 10.0.0.2, wildcard bits 0.0.0.255
Router(config)# ip access-list standard tryon
Router(config-std-nacl)# 15 permit 10.5.5.5 0.0.0.255
Router# show ip access-list
Standard IP access list tryon
 2 permit 10.4.0.0, wildcard bits 0.0.255.255
 5 permit 10.0.0.0, wildcard bits 0.0.0.255
10 permit 10.0.0.0, wildcard bits 0.0.0.255
15 permit 10.5.5.5, wildcard bits 0.0.0.255
```

## Example Adding an Entry with No Sequence Number

```
15 permit 10.5.5.0, wildcard bits 0.0.0.255
20 permit 10.0.0.0, wildcard bits 0.0.0.255
```

## Example Adding an Entry with No Sequence Number

The following example shows how an entry with no specified sequence number is added to the end of an access list. When an entry is added without a sequence number, it is automatically given a sequence number that puts it at the end of the access list. Because the default increment is 10, the entry will have a sequence number 10 higher than the last entry in the existing access list.

```
Router(config)# ip access-list standard resources
Router(config-std-nacl)# permit 10.1.1.1 0.0.0.255
Router(config-std-nacl)# permit 10.2.2.2 0.0.0.255
Router(config-std-nacl)# permit 10.3.3.3 0.0.0.255
Router# show access-list
Standard IP access list resources
10 permit 10.1.1.1, wildcard bits 0.0.0.255
20 permit 10.2.2.2, wildcard bits 0.0.0.255
30 permit 10.3.3.3, wildcard bits 0.0.0.255
Router(config)# ip access-list standard resources
Router(config-std-nacl)# permit 10.4.4.4 0.0.0.255
Router(config-std-nacl)# end
Router# show access-list
Standard IP access list resources
10 permit 10.1.1.1, wildcard bits 0.0.0.255
20 permit 10.2.2.2, wildcard bits 0.0.0.255
30 permit 10.3.3.3, wildcard bits 0.0.0.255
40 permit 10.4.4.4, wildcard bits 0.0.0.255
```

## Example Time Ranges Applied to IP Access List Entries

The following example creates a time range called no-http, which extends from Monday to Friday from 8:00 a.m. to 6:00 p.m. That time range is applied to the **deny** statement, thereby denying HTTP traffic on Monday through Friday from 8:00 a.m. to 6:00 p.m.

The time range called udp-yes defines weekends from noon to 8:00 p.m. That time range is applied to the **permit** statement, thereby allowing UDP traffic on Saturday and Sunday from noon to 8:00 p.m. only. The access list containing both statements is applied to inbound packets on Ten Gigabit Ethernet interface 4/1/0.

```
time-range no-http
 periodic weekdays 8:00 to 18:00
 !
time-range udp-yes
 periodic weekend 12:00 to 20:00
 !
ip access-list extended strict
 deny tcp any any eq http time-range no-http
 permit udp any any time-range udp-yes
 !
interface TenGigabitEthernet4/1/0
 ip access-group strict in
```

## Example Filtering IP Packet Fragments

In the following access list, the first statement will deny only noninitial fragments destined for host 172.16.1.1. The second statement will permit only the remaining nonfragmented and initial fragments that are destined

for host 172.16.1.1 TCP port 80. The third statement will deny all other traffic. In order to block noninitial fragments for any TCP port, we must block noninitial fragments for all TCP ports, including port 80 for host 172.16.1.1. That is, non-initial fragments will not contain Layer 4 port information, so, in order to block such traffic for a given port, we have to block fragments for all ports.

```
access-list 101 deny ip any host 172.16.1.1 fragments
access-list 101 permit tcp any host 172.16.1.1 eq 80
access-list 101 deny ip any any
```

## Additional References

### Related Documents

| Related Topic                                                | Document Title                                                                                                          |
|--------------------------------------------------------------|-------------------------------------------------------------------------------------------------------------------------|
| Using the <b>time-range</b> command to establish time ranges | The chapter <i>Performing Basic System Management</i> in the <i>Cisco IOS XE Network Management Configuration Guide</i> |
| Network management command descriptions                      | <i>Cisco IOS Network Management Command Reference</i>                                                                   |

### Standards

| Standard                                                                                                                              | Title |
|---------------------------------------------------------------------------------------------------------------------------------------|-------|
| No new or modified standards are supported by this feature, and support for existing standards has not been modified by this feature. | --    |

### MIBs

| MIB                                                                                                                         | MIBs Link                                                                                                                                                                                                                              |
|-----------------------------------------------------------------------------------------------------------------------------|----------------------------------------------------------------------------------------------------------------------------------------------------------------------------------------------------------------------------------------|
| No new or modified MIBs are supported by this feature, and support for existing MIBs has not been modified by this feature. | To locate and download MIBs for selected platforms, Cisco IOS XE software releases, and feature sets, use Cisco MIB Locator found at the following URL:<br><br><a href="http://www.cisco.com/go/mibs">http://www.cisco.com/go/mibs</a> |

### RFCs

| RFC                                                                                                                         | Title |
|-----------------------------------------------------------------------------------------------------------------------------|-------|
| No new or modified RFCs are supported by this feature, and support for existing RFCs has not been modified by this feature. | --    |

**Technical Assistance**

| Description                                                                                                                                                                                                                                                                                                                                                                           | Link                                                                                                              |
|---------------------------------------------------------------------------------------------------------------------------------------------------------------------------------------------------------------------------------------------------------------------------------------------------------------------------------------------------------------------------------------|-------------------------------------------------------------------------------------------------------------------|
| The Cisco Support and Documentation website provides online resources to download documentation, software, and tools. Use these resources to install and configure the software and to troubleshoot and resolve technical issues with Cisco products and technologies. Access to most tools on the Cisco Support and Documentation website requires a Cisco.com user ID and password. | <a href="http://www.cisco.com/cisco/web/support/index.html">http://www.cisco.com/cisco/web/support/index.html</a> |

## Feature Information for Refining an IP Access List

Use Cisco Feature Navigator to find information about the platform support and software image support. Cisco Feature Navigator enables you to determine which software images support a specific software release, feature set, or platform. To access Cisco Feature Navigator, go to the <https://cfng.cisco.com/> link. An account on the Cisco.com page is not required.



**Note** The following table lists the software release in which a given feature is introduced. Unless noted otherwise, subsequent releases of that software release train also support that feature.

*Table 245: Feature Information for Refining an IP Access List*

| Feature Name    | Releases                 | Feature Information                                                                                            |
|-----------------|--------------------------|----------------------------------------------------------------------------------------------------------------|
| IP access lists | Cisco IOS XE Fuji 16.7.1 | This feature was integrated into Cisco IOS XE Fuji 16.7.1 on the Cisco cBR Series Converged Broadband Routers. |



## CHAPTER 72

# IP Named Access Control Lists

---

Access control lists (ACLs) perform packet filtering to control the movement of packets through a network. Packet filtering provides security by limiting the access of traffic into a network, restricting user and device access to a network, and preventing traffic from leaving a network. IP access lists reduce the chance of spoofing and denial-of-service attacks, and allow dynamic, temporary user-access through a firewall.

The IP Named Access Control Lists feature gives network administrators the option of using names to identify their access lists.

This module describes IP named access lists and how to configure them.

Your software release may not support all the features that are documented in this module. For the latest feature information and caveats, see the release notes for your platform and software release. The Feature Information Table at the end of this document provides information about the documented features and lists the releases in which each feature is supported.

Use Cisco Feature Navigator to find information about platform support and Cisco software image support. To access Cisco Feature Navigator, go to <http://tools.cisco.com/ITDIT/CFN/>. An account on <http://www.cisco.com/> is not required.

### Contents

- [Hardware Compatibility Matrix for the Cisco cBR Series Routers, on page 1195](#)
- [Information About IP Named Access Control Lists, on page 1197](#)
- [How to Configure IP Named Access Control Lists, on page 1201](#)
- [Additional References for IP Named Access Control Lists, on page 1203](#)
- [Feature Information for IP Named Access Control Lists, on page 1204](#)

## Hardware Compatibility Matrix for the Cisco cBR Series Routers



---

**Note** The hardware components that are introduced in a given Cisco IOS-XE Release are supported in all subsequent releases unless otherwise specified.

---

Table 246: Hardware Compatibility Matrix for the Cisco cBR Series Routers

| Cisco CMTS Platform                    | Processor Engine                                                                                                                                                                                  | Interface Cards                                                                                                                                                                                                                                                                                                                                                                                                                                                                                                                                                                                                                                                                                                                                                                                 |
|----------------------------------------|---------------------------------------------------------------------------------------------------------------------------------------------------------------------------------------------------|-------------------------------------------------------------------------------------------------------------------------------------------------------------------------------------------------------------------------------------------------------------------------------------------------------------------------------------------------------------------------------------------------------------------------------------------------------------------------------------------------------------------------------------------------------------------------------------------------------------------------------------------------------------------------------------------------------------------------------------------------------------------------------------------------|
| Cisco cBR-8 Converged Broadband Router | <p><b>Cisco IOS-XE Release 16.5.1 and Later Releases</b></p> <p>Cisco cBR-8 Supervisor:</p> <ul style="list-style-type: none"> <li>• PID—CBR-SUP-250G</li> <li>• PID—CBR-CCAP-SUP-160G</li> </ul> | <p><b>Cisco IOS-XE Release 16.5.1 and Later Releases</b></p> <p>Cisco cBR-8 CCAP Line Cards:</p> <ul style="list-style-type: none"> <li>• PID—CBR-LC-8D30-16U30</li> <li>• PID—CBR-LC-8D31-16U30</li> <li>• PID—CBR-RF-PIC</li> <li>• PID—CBR-RF-PROT-PIC</li> <li>• PID—CBR-CCAP-LC-40G</li> <li>• PID—CBR-CCAP-LC-40G-R</li> <li>• PID—CBR-CCAP-LC-G2-R</li> <li>• PID—CBR-SUP-8X10G-PIC</li> <li>• PID—CBR-2X100G-PIC</li> </ul> <p>Digital PICs:</p> <ul style="list-style-type: none"> <li>• PID—CBR-DPIC-8X10G</li> <li>• PID—CBR-DPIC-2X100G</li> </ul> <p>Cisco cBR-8 Downstream PHY Module:</p> <ul style="list-style-type: none"> <li>• PID—CBR-D31-DS-MOD</li> </ul> <p>Cisco cBR-8 Upstream PHY Modules:</p> <ul style="list-style-type: none"> <li>• PID—CBR-D31-US-MOD</li> </ul> |



**Note** Do not use DPICs (8X10G and 2x100G) to forward IP traffic, as it may cause buffer exhaustion, leading to line card reload.

The only allowed traffic on a DPIC interface is DEPI, UEPI, and GCP traffic from the Cisco cBR-8 router to Remote PHY devices. Other traffic such as DHCP, SSH, and UTSC should flow via another router, since DPICs cannot be used for normal routing.



# Information About IP Named Access Control Lists

## Definition of an Access List

Access control lists (ACLs) perform packet filtering to control the movement of packets through a network. Packet filtering provides security by limiting the access of traffic into a network, restricting user and device access to a network, and preventing traffic from leaving a network. IP access lists reduce the chance of spoofing and denial-of-service attacks, and allow dynamic, temporary user-access through a firewall.

IP access lists can also be used for purposes other than security, such as to control bandwidth, restrict the content of routing updates, redistribute routes, trigger dial-on-demand (DDR) calls, limit debug output, and identify or classify traffic for quality of service (QoS) features.

An access list is a sequential list that consists of at least one **permit** statement and possibly one or more **deny** statements. In the case of IP access lists, these statements can apply to IP addresses, upper-layer IP protocols, or other fields in IP packets.

Access lists are identified and referenced by a name or a number. Access lists act as packet filters, filtering packets based on the criteria defined in each access list.

After you configure an access list, for the access list to take effect, you must either apply the access list to an interface (by using the **ip access-group** command), a vty (by using the **access-class** command), or reference the access list by any command that accepts an access list. Multiple commands can reference the same access list.

In the following configuration, an IP access list named `branchoffices` is configured on Ten Gigabit Ethernet interface 4/1/0 and applied to incoming packets. Networks other than the ones specified by the source address and mask pair cannot access Ten Gigabit Ethernet interface 4/1/0. The destinations for packets coming from sources on network 172.16.7.0 are unrestricted. The destination for packets coming from sources on network 172.16.2.0 must be 172.31.5.4.

```
ip access-list extended branchoffices
 10 permit 172.16.7.0 0.0.0.3 any
 20 permit 172.16.2.0 0.0.0.255 host 172.31.5.4
!
interface TenGigabitEthernet4/1/0
 ip access-group branchoffices in
```

## Named or Numbered Access Lists

All access lists must be identified by a name or a number. Named access lists are more convenient than numbered access lists because you can specify a meaningful name that is easier to remember and associate with a task. You can reorder statements in or add statements to a named access list.

Named access lists support the following features that are not supported by numbered access lists:

- IP options filtering
- Noncontiguous ports
- TCP flag filtering
- Deleting of entries with the **no permit** or **no deny** command



**Note** Not all commands that accept a numbered access list will accept a named access list. For example, vty uses only numbered access lists.

## Benefits of IP Access Lists

Access control lists (ACLs) perform packet filtering to control the flow of packets through a network. Packet filtering can restrict the access of users and devices to a network, providing a measure of security. Access lists can save network resources by reducing traffic. The benefits of using access lists are as follows:

- Authenticate incoming rsh and rcp requests—Access lists can simplify the identification of local users, remote hosts, and remote users in an authentication database that is configured to control access to a device. The authentication database enables Cisco software to receive incoming remote shell (rsh) and remote copy (rcp) protocol requests.
- Block unwanted traffic or users—Access lists can filter incoming or outgoing packets on an interface, thereby controlling access to a network based on source addresses, destination addresses, or user authentication. You can also use access lists to determine the types of traffic that are forwarded or blocked at device interfaces. For example, you can use access lists to permit e-mail traffic to be routed through a network and to block all Telnet traffic from entering the network.
- Control access to vty—Access lists on an inbound vty (Telnet) can control who can access the lines to a device. Access lists on an outbound vty can control the destinations that the lines from a device can reach.
- Identify or classify traffic for QoS features—Access lists provide congestion avoidance by setting the IP precedence for Weighted Random Early Detection (WRED) and committed access rate (CAR). Access lists also provide congestion management for class-based weighted fair queueing (CBWFQ), priority queueing, and custom queueing.
- Limit debug command output—Access lists can limit debug output based on an IP address or a protocol.
- Provide bandwidth control—Access lists on a slow link can prevent excess traffic on a network.
- Provide NAT control—Access lists can control which addresses are translated by Network Address Translation (NAT).
- Reduce the chance of DoS attacks—Access lists reduce the chance of denial-of-service (DoS) attacks. Specify IP source addresses to control traffic from hosts, networks, or users from accessing your network. Configure the TCP Intercept feature to can prevent servers from being flooded with requests for connection.
- Restrict the content of routing updates—Access lists can control routing updates that are sent, received, or redistributed in networks.
- Trigger dial-on-demand calls—Access lists can enforce dial and disconnect criteria.

## Access List Rules

The following rules apply to access lists:

- Only one access list per interface, per protocol, and per direction is allowed.

- An access list must contain at least one **permit** statement or all packets are denied entry into the network.
- The order in which access list conditions or match criteria are configured is important. While deciding whether to forward or block a packet, Cisco software tests the packet against each criteria statement in the order in which these statements are created. After a match is found, no more criteria statements are checked. The same **permit** or **deny** statements specified in a different order can result in a packet being passed under one circumstance and denied in another circumstance.
- If an access list is referenced by a name, but the access list does not exist, all packets pass. An interface or command with an empty access list applied to it permits all traffic into the network.
- Standard access lists and extended access lists cannot have the same name.
- Inbound access lists process packets before the packets are routed to an outbound interface. Inbound access lists that have filtering criteria that deny packet access to a network saves the overhead of routing lookup. Packets that are permitted access to a network based on the configured filtering criteria are processed for routing. For inbound access lists, when you configure a **permit** statement, packets are processed after they are received, and when you configure a **deny** statement, packets are discarded.
- Outbound access lists process packets before they leave the device. Incoming packets are routed to the outbound interface and then processed by the outbound access list. For outbound access lists, when you configure a **permit** statement, packets are sent to the output buffer, and when you configure a **deny** statement, packets are discarded.
- An access list can control traffic arriving at a device or leaving a device, but not traffic originating at a device.

## Helpful Hints for Creating IP Access Lists

The following tips will help you avoid unintended consequences and help you create more efficient, useful access lists.

- Create the access list before applying it to an interface (or elsewhere), because if you apply a nonexistent access list to an interface and then proceed to configure the access list, the first statement is put into effect, and the implicit **deny** statement that follows could cause you immediate access problems.
- Another reason to configure an access list before applying it is because an interface with an empty access list applied to it permits all traffic.
- All access lists need at least one **permit** statement; otherwise, all packets are denied and no traffic passes.
- Because the software stops testing conditions after it encounters the first match (to either a **permit** or **deny** statement), you will reduce processing time and resources if you put the statements that packets are most likely to match at the beginning of the access list. Place more frequently occurring conditions before less frequent conditions.
- Organize your access list so that more specific references in a network or subnet appear before more general ones.
- Use the statement **permit any any** if you want to allow all other packets not already denied. Using the statement **permit any any** in effect avoids denying all other packets with the implicit deny statement at the end of an access list. Do not make your first access list entry **permit any any** because all traffic will get through; no packets will reach the subsequent testing. In fact, once you specify **permit any any**, all traffic not already denied will get through.

- Although all access lists end with an implicit **deny** statement, we recommend use of an explicit **deny** statement (for example, **deny ip any any**). On most platforms, you can display the count of packets denied by issuing the **show access-list** command, thus finding out more information about who your access list is disallowing. Only packets denied by explicit **deny** statements are counted, which is why the explicit **deny** statement will yield more complete data for you.
- While you are creating an access list or after it is created, you might want to delete an entry.
  - You cannot delete an entry from a numbered access list; trying to do so will delete the entire access list. If you need to delete an entry, you need to delete the entire access list and start over.
  - You can delete an entry from a named access list. Use the **no permit** or **no deny** command to delete the appropriate entry.
- In order to make the purpose of individual statements more scannable and easily understood at a glance, you can write a helpful remark before or after any statement by using the **remark** command.
- If you want to deny access to a particular host or network and find out if someone from that network or host is attempting to gain access, include the **log** keyword with the corresponding **deny** statement so that the packets denied from that source are logged for you.
- This hint applies to the placement of your access list. When trying to save resources, remember that an inbound access list applies the filter conditions before the routing table lookup. An outbound access list applies the filter conditions after the routing table lookup.
- Before you add new ACL statements, provide time to the parser to clean up the deletion.

## Where to Apply an Access List

You can apply access lists to the inbound or outbound interfaces of a device. Applying an access list to an inbound interface controls the traffic that enters the interface and applying an access list to an outbound interface controls the traffic that exits the interface.

When software receives a packet at the inbound interface, the software checks the packet against the statements that are configured for the access list. If the access list permits packets, the software processes the packet. Applying access lists to filter incoming packets can save device resources because filtered packets are discarded before entering the device.

Access lists on outbound interfaces filter packets that are transmitted (sent) out of the interface. You can use the TCP Access Control List (ACL) Splitting feature of the Rate-Based Satellite Control Protocol (RBSCP) on the outbound interface to control the type of packets that are subject to TCP acknowledgment (ACK) splitting on an outbound interface.

You can reference an access list by using a **debug** command to limit the amount of debug logs. For example, based on the filtering or matching criteria of the access list, debug logs can be limited to source or destination addresses or protocols.

You can use access lists to control routing updates, dial-on-demand (DDR), and quality of service (QoS) features.

# How to Configure IP Named Access Control Lists

## Creating an IP Named Access List

You can create an IP named access list to filter source addresses and destination addresses or a combination of addresses and other IP fields. Named access lists allow you to identify your access lists with an intuitive name.

### SUMMARY STEPS

1. **enable**
2. **configure terminal**
3. **ip access-list extended** *name*
4. **remark** *remark*
5. **deny** *protocol* [*source source-wildcard*] {**any** | **host** {*address* | *name*} } {*destination* [*destination-wildcard*] {**any** | **host** {*address* | *name*} } [**log**]
6. **remark** *remark*
7. **permit** *protocol* [*source source-wildcard*] {**any** | **host** {*address* | *name*} } {*destination* [*destination-wildcard*] {**any** | **host** {*address* | *name*} } [**log**]
8. Repeat Steps 4 through 7 to specify more statements for your access list.
9. **end**
10. **show ip access-lists**

### DETAILED STEPS

|        | Command or Action                                                                                                                            | Purpose                                                                                                                                                                                                                                                                                                        |
|--------|----------------------------------------------------------------------------------------------------------------------------------------------|----------------------------------------------------------------------------------------------------------------------------------------------------------------------------------------------------------------------------------------------------------------------------------------------------------------|
| Step 1 | <b>enable</b><br><b>Example:</b><br>Device> enable                                                                                           | Enables privileged EXEC mode.<br>• Enter your password if prompted.                                                                                                                                                                                                                                            |
| Step 2 | <b>configure terminal</b><br><b>Example:</b><br>Device# configure terminal                                                                   | Enters global configuration mode.                                                                                                                                                                                                                                                                              |
| Step 3 | <b>ip access-list extended</b> <i>name</i><br><b>Example:</b><br>Device(config)# ip access-list extended acl1                                | Defines an extended IP access list using a name and enters extended named access list configuration mode.                                                                                                                                                                                                      |
| Step 4 | <b>remark</b> <i>remark</i><br><b>Example:</b><br>Device(config-ext-nacl)# remark protect server by denying sales access to the acl1 network | (Optional) Adds a description for an access list statement.<br>• A remark can precede or follow an IP access list entry.<br>• In this example, the <b>remark</b> command reminds the network administrator that the <b>deny</b> command configured in Step 5 denies the Sales network access to the interface. |

|                | Command or Action                                                                                                                                                                                                                                                                                                                                                | Purpose                                                                                                                                                                 |
|----------------|------------------------------------------------------------------------------------------------------------------------------------------------------------------------------------------------------------------------------------------------------------------------------------------------------------------------------------------------------------------|-------------------------------------------------------------------------------------------------------------------------------------------------------------------------|
| <b>Step 5</b>  | <p><b>deny</b> <i>protocol</i> [<i>source source-wildcard</i>] {<b>any</b>   <b>host</b> {<i>address</i>   <i>name</i>} {<i>destination</i> [<i>destination-wildcard</i>] {<b>any</b>   <b>host</b> {<i>address</i>   <i>name</i>} [<b>log</b>]</p> <p><b>Example:</b></p> <pre>Device(config-ext-nacl)# deny ip 192.0.2.0 0.0.255.255 host 192.0.2.10 log</pre> | (Optional) Denies all packets that match all conditions specified by the remark.                                                                                        |
| <b>Step 6</b>  | <p><b>remark</b> <i>remark</i></p> <p><b>Example:</b></p> <pre>Device(config-ext-nacl)# remark allow TCP from any source to any destination</pre>                                                                                                                                                                                                                | (Optional) Adds a description for an access list statement. <ul style="list-style-type: none"> <li>• A remark can precede or follow an IP access list entry.</li> </ul> |
| <b>Step 7</b>  | <p><b>permit</b> <i>protocol</i> [<i>source source-wildcard</i>] {<b>any</b>   <b>host</b> {<i>address</i>   <i>name</i>} {<i>destination</i> [<i>destination-wildcard</i>] {<b>any</b>   <b>host</b> {<i>address</i>   <i>name</i>} [<b>log</b>]</p> <p><b>Example:</b></p> <pre>Device(config-ext-nacl)# permit tcp any any</pre>                              | Permits all packets that match all conditions specified by the statement.                                                                                               |
| <b>Step 8</b>  | Repeat Steps 4 through 7 to specify more statements for your access list.                                                                                                                                                                                                                                                                                        | <b>Note</b> All source addresses that are not specifically permitted by a statement are denied by an implicit deny statement at the end of the access list.             |
| <b>Step 9</b>  | <p><b>end</b></p> <p><b>Example:</b></p> <pre>Device(config-ext-nacl)# end</pre>                                                                                                                                                                                                                                                                                 | Exits extended named access list configuration mode and returns to privileged EXEC mode.                                                                                |
| <b>Step 10</b> | <p><b>show ip access-lists</b></p> <p><b>Example:</b></p> <pre>Device# show ip access-lists</pre>                                                                                                                                                                                                                                                                | Displays the contents of all current IP access lists.                                                                                                                   |

**Example:**

The following is sample output from the **show ip access-lists** command:

```
Device# show ip access-lists acl1

Extended IP access list acl1
 permit tcp any 192.0.2.0 255.255.255.255 eq telnet
 deny tcp any any
 deny udp any 192.0.2.0 255.255.255.255 lt 1024
 deny ip any any log
```

## Applying an Access List to an Interface

### Procedure

|               | Command or Action                                                                                                                                                             | Purpose                                                                                                                                                                                     |
|---------------|-------------------------------------------------------------------------------------------------------------------------------------------------------------------------------|---------------------------------------------------------------------------------------------------------------------------------------------------------------------------------------------|
| <b>Step 1</b> | <b>enable</b><br><b>Example:</b><br>Device> enable                                                                                                                            | Enables privileged EXEC mode. <ul style="list-style-type: none"> <li>• Enter your password if prompted.</li> </ul>                                                                          |
| <b>Step 2</b> | <b>configure terminal</b><br><b>Example:</b><br>Device# configure terminal                                                                                                    | Enters global configuration mode.                                                                                                                                                           |
| <b>Step 3</b> | <b>interface</b> <i>type number</i><br><b>Example:</b><br>Device(config)# interface TenGigabitEthernet4/1/0                                                                   | Specifies an interface and enters interface configuration mode.                                                                                                                             |
| <b>Step 4</b> | <b>ip access-group</b> { <i>access-list-number</i>   <i>access-list-name</i> }<br>{ <b>in</b>   <b>out</b> }<br><b>Example:</b><br>Device(config-if)# ip access-group acl1 in | Applies the specified access list to the inbound interface. <ul style="list-style-type: none"> <li>• To filter source addresses, apply the access list to the inbound interface.</li> </ul> |
| <b>Step 5</b> | <b>end</b><br><b>Example:</b><br>Device(config-if)# end                                                                                                                       | Exits interface configuration mode and returns to privileged EXEC mode.                                                                                                                     |

## Additional References for IP Named Access Control Lists

### Related Documents

| Related Topic     | Document Title                                                                                                                                                                                                                                                                                                                                                               |
|-------------------|------------------------------------------------------------------------------------------------------------------------------------------------------------------------------------------------------------------------------------------------------------------------------------------------------------------------------------------------------------------------------|
| Security commands | <ul style="list-style-type: none"> <li>• <a href="#">Cisco IOS Security Command Reference: Commands A to C</a></li> <li>• <a href="#">Cisco IOS Security Command Reference: Commands D to L</a></li> <li>• <a href="#">Cisco IOS Security Command Reference: Commands M to R</a></li> <li>• <a href="#">Cisco IOS Security Command Reference: Commands S to Z</a></li> </ul> |

**Technical Assistance**

| Description                                                                                                                                                                                                                                                                                                                                                                           | Link                                                                                                              |
|---------------------------------------------------------------------------------------------------------------------------------------------------------------------------------------------------------------------------------------------------------------------------------------------------------------------------------------------------------------------------------------|-------------------------------------------------------------------------------------------------------------------|
| The Cisco Support and Documentation website provides online resources to download documentation, software, and tools. Use these resources to install and configure the software and to troubleshoot and resolve technical issues with Cisco products and technologies. Access to most tools on the Cisco Support and Documentation website requires a Cisco.com user ID and password. | <a href="http://www.cisco.com/cisco/web/support/index.html">http://www.cisco.com/cisco/web/support/index.html</a> |

## Feature Information for IP Named Access Control Lists

Use Cisco Feature Navigator to find information about the platform support and software image support. Cisco Feature Navigator enables you to determine which software images support a specific software release, feature set, or platform. To access Cisco Feature Navigator, go to the <https://cfng.cisco.com/> link. An account on the Cisco.com page is not required.



**Note** The following table lists the software release in which a given feature is introduced. Unless noted otherwise, subsequent releases of that software release train also support that feature.

**Table 247: Feature Information for IP Named Access Control Lists**

| Feature Name    | Releases                 | Feature Information                                                                                            |
|-----------------|--------------------------|----------------------------------------------------------------------------------------------------------------|
| IP access lists | Cisco IOS XE Fuji 16.7.1 | This feature was integrated into Cisco IOS XE Fuji 16.7.1 on the Cisco cBR Series Converged Broadband Routers. |





## CHAPTER 73

# IPv4 ACL Chaining Support

ACL Chaining, also known as Multi-Access Control List, allows you to split access control lists (ACLs). This module describes how with the IPv4 ACL Chaining Support feature, you can explicitly split ACLs into common and user-specific ACLs and bind both ACLs to a target for traffic filtering on a device. In this way, the common ACLs in Ternary Content Addressable Memory (TCAM) are shared by multiple targets, thereby reducing the resource usage.

Your software release may not support all the features that are documented in this module. For the latest feature information and caveats, see the release notes for your platform and software release. The Feature Information Table at the end of this document provides information about the documented features and lists the releases in which each feature is supported.

Use Cisco Feature Navigator to find information about platform support and Cisco software image support. To access Cisco Feature Navigator, go to <http://tools.cisco.com/ITDIT/CFN/>. An account on <http://www.cisco.com/> is not required.

### Contents

- [Hardware Compatibility Matrix for the Cisco cBR Series Routers, on page 1205](#)
- [Restrictions for IPv4 ACL Chaining Support, on page 1207](#)
- [Information About IPv4 ACL Chaining Support, on page 1207](#)
- [How to Configure IPv4 ACL Chaining Support, on page 1208](#)
- [Configuration Examples for IPv4 ACL Chaining Support, on page 1208](#)
- [Additional References for IPv4 ACL Chaining Support, on page 1209](#)
- [Feature Information for IPv4 ACL Chaining Support, on page 1210](#)

## Hardware Compatibility Matrix for the Cisco cBR Series Routers



**Note** The hardware components that are introduced in a given Cisco IOS-XE Release are supported in all subsequent releases unless otherwise specified.

Table 248: Hardware Compatibility Matrix for the Cisco cBR Series Routers

| Cisco CMTS Platform                    | Processor Engine                                                                                                                                                                                  | Interface Cards                                                                                                                                                                                                                                                                                                                                                                                                                                                                                                                                                                                                                                                                                                                                                                                 |
|----------------------------------------|---------------------------------------------------------------------------------------------------------------------------------------------------------------------------------------------------|-------------------------------------------------------------------------------------------------------------------------------------------------------------------------------------------------------------------------------------------------------------------------------------------------------------------------------------------------------------------------------------------------------------------------------------------------------------------------------------------------------------------------------------------------------------------------------------------------------------------------------------------------------------------------------------------------------------------------------------------------------------------------------------------------|
| Cisco cBR-8 Converged Broadband Router | <p><b>Cisco IOS-XE Release 16.5.1 and Later Releases</b></p> <p>Cisco cBR-8 Supervisor:</p> <ul style="list-style-type: none"> <li>• PID—CBR-SUP-250G</li> <li>• PID—CBR-CCAP-SUP-160G</li> </ul> | <p><b>Cisco IOS-XE Release 16.5.1 and Later Releases</b></p> <p>Cisco cBR-8 CCAP Line Cards:</p> <ul style="list-style-type: none"> <li>• PID—CBR-LC-8D30-16U30</li> <li>• PID—CBR-LC-8D31-16U30</li> <li>• PID—CBR-RF-PIC</li> <li>• PID—CBR-RF-PROT-PIC</li> <li>• PID—CBR-CCAP-LC-40G</li> <li>• PID—CBR-CCAP-LC-40G-R</li> <li>• PID—CBR-CCAP-LC-G2-R</li> <li>• PID—CBR-SUP-8X10G-PIC</li> <li>• PID—CBR-2X100G-PIC</li> </ul> <p>Digital PICs:</p> <ul style="list-style-type: none"> <li>• PID—CBR-DPIC-8X10G</li> <li>• PID—CBR-DPIC-2X100G</li> </ul> <p>Cisco cBR-8 Downstream PHY Module:</p> <ul style="list-style-type: none"> <li>• PID—CBR-D31-DS-MOD</li> </ul> <p>Cisco cBR-8 Upstream PHY Modules:</p> <ul style="list-style-type: none"> <li>• PID—CBR-D31-US-MOD</li> </ul> |



**Note** Do not use DPICs (8X10G and 2x100G) to forward IP traffic, as it may cause buffer exhaustion, leading to line card reload.

The only allowed traffic on a DPIC interface is DEPI, UEPI, and GCP traffic from the Cisco cBR-8 router to Remote PHY devices. Other traffic such as DHCP, SSH, and UTSC should flow via another router, since DPICs cannot be used for normal routing.

# Restrictions for IPv4 ACL Chaining Support

- A single access control List (ACL) cannot be used for both common and regular ACLs for the same target in the same direction.
- ACL chaining applies to only security ACLs. It is not supported for feature policies, such as Quality of Service (QoS), Firewall Services Module (FW) and Policy Based Routing (PBR).
- Per-target statistics are not supported for common ACLs.

## Information About IPv4 ACL Chaining Support

### ACL Chaining Overview

The packet filter process supports only a single Access control list (ACL) to be applied per direction and per protocol on an interface. This leads to manageability and scalability issues if there are common ACL entries needed on many interfaces. Duplicate Access control entries (ACEs) are configured for all those interfaces, and any modification to the common ACEs needs to be performed for all ACLs.

A typical ACL on the edge box for an Internet Service Provider (ISP) has two sets of ACEs:

- Common ISP specific ACEs
- Customer/interface specific ACEs

The purpose of these address blocks is to deny access to ISP's protected infrastructure networks and anti-spoofing protection by allowing only customer source address blocks. This results in configuring unique ACL per interface and most of the ACEs being common across all ACLs on a device. ACL provisioning and modification is very cumbersome, hence, any changes to the ACE impacts every target.

### IPv4 ACL Chaining Support

IPv4 ACL Chaining Support allows you to split the Access control list (ACL) into common and customer-specific ACLs and attach both ACLs to a common session. In this way, only one copy of the common ACL is attached to Ternary Content Addressable Memory (TCAM) and shared by all users, thereby making it easier to maintain the common ACEs.

The IPv4 ACL Chaining feature allows two IPV4 ACLs to be active on an interface per direction:

- Common
- Regular
- Common and Regular



---

**Note** If you configure both common and regular ACLs on an interface, the common ACL is considered over a regular ACL.

---

# How to Configure IPv4 ACL Chaining Support

ACL chaining is supported by extending the **ip traffic filter** command.

The **ip traffic filter** command is not additive. When you use this command, it replaces earlier instances of the command.

For more information, refer to the *IPv6 ACL Chaining with a Common ACL* section in the Security Configuration Guide: Access Control Lists Configuration Guide.

## Configuring an Interface to Accept Common ACL

Perform this task to configure the interface to accept a common Access control list (ACL) along with an interface-specific ACL:

### Procedure

|               | Command or Action                                                                                                                                                                                                                   | Purpose                                                                                |
|---------------|-------------------------------------------------------------------------------------------------------------------------------------------------------------------------------------------------------------------------------------|----------------------------------------------------------------------------------------|
| <b>Step 1</b> | <b>enable</b><br><b>Example:</b><br>Device> enable                                                                                                                                                                                  | Enables privileged EXEC mode. Enter your password if prompted.                         |
| <b>Step 2</b> | <b>configure terminal</b><br><b>Example:</b><br>Device# configure terminal                                                                                                                                                          | Enters global configuration mode.                                                      |
| <b>Step 3</b> | <b>interface</b> <i>type number</i><br><b>Example:</b><br>Device(config)# interface TenGigabitEthernet4/1/0                                                                                                                         | Configures an interface and enters the interface configuration mode.                   |
| <b>Step 4</b> | <b>ip access-group</b> { <b>common</b> { <i>common-access-list-name</i> { <i>regular-access-list</i>   <b>acl</b> }} { <b>in</b>   <b>out</b> }}<br><b>Example:</b><br>Device(config-if)# ipv4 access-group common acl-p<br>acl1 in | Configures the interface to accept a common ACL along with the interface-specific ACL. |
| <b>Step 5</b> | <b>end</b><br><b>Example:</b><br>Device(config-if)# end                                                                                                                                                                             | (Optional) Exits the configuration mode and returns to privileged EXEC mode.           |

## Configuration Examples for IPv4 ACL Chaining Support

This section provides configuration examples of Common Access Control List (ACL).

## Example: Configuring an Interface to Accept a Common ACL

This example shows how to replace an Access Control List (ACL) configured on the interface without explicitly deleting the ACL:

```
interface TenGigabitEthernet4/1/0
ipv4 access-group common C_acl ACL1 in
end
replace interface acl ACL1 by ACL2
interface TenGigabitEthernet4/1/0
ipv4 access-group common C_acl ACL2 in
end
```

This example shows how common ACL cannot be replaced on interfaces without deleting it explicitly from the interface:

```
interface TenGigabitEthernet4/1/0
ipv4 access-group common C_acl1 ACL1 in
end
change the common acl to C_acl2
interface TenGigabitEthernet4/1/0
no ipv4 access-group common C_acl1 ACL1 in
end
interface TenGigabitEthernet4/1/0
ipv4 access-group common C_acl2 ACL1 in
end
```



**Note** When reconfiguring a common ACL, you must ensure that no other interface on the line card is attached to the common ACL.



**Note** If both common ACL and interface ACL are attached to an interface and only one of the above is reconfigured on the interface, then the other is removed automatically.

This example shows how the interface ACL is removed:

```
interface TenGigabitEthernet4/1/0
ipv4 access-group common C_acl1 ACL1 in
end
```

## Additional References for IPv4 ACL Chaining Support

### Related Documents

| Related Topic             | Document Title                                                     |
|---------------------------|--------------------------------------------------------------------|
| IPv6 ACL Chaining Support | <a href="#">Security Configuration Guide: Access Control Lists</a> |

| Related Topic     | Document Title                                                                                                                                                                                                                                                                                                                                                               |
|-------------------|------------------------------------------------------------------------------------------------------------------------------------------------------------------------------------------------------------------------------------------------------------------------------------------------------------------------------------------------------------------------------|
| Security commands | <ul style="list-style-type: none"> <li>• <a href="#">Cisco IOS Security Command Reference: Commands A to C</a></li> <li>• <a href="#">Cisco IOS Security Command Reference: Commands D to L</a></li> <li>• <a href="#">Cisco IOS Security Command Reference: Commands M to R</a></li> <li>• <a href="#">Cisco IOS Security Command Reference: Commands S to Z</a></li> </ul> |

### Technical Assistance

| Description                                                                                                                                                                                                                                                                                                                                                                                                                                                                                                                                                             | Link                                                                    |
|-------------------------------------------------------------------------------------------------------------------------------------------------------------------------------------------------------------------------------------------------------------------------------------------------------------------------------------------------------------------------------------------------------------------------------------------------------------------------------------------------------------------------------------------------------------------------|-------------------------------------------------------------------------|
| <p>The Cisco Support website provides extensive online resources, including documentation and tools for troubleshooting and resolving technical issues with Cisco products and technologies.</p> <p>To receive security and technical information about your products, you can subscribe to various services, such as the Product Alert Tool (accessed from Field Notices), the Cisco Technical Services Newsletter, and Really Simple Syndication (RSS) Feeds.</p> <p>Access to most tools on the Cisco Support website requires a Cisco.com user ID and password.</p> | <a href="http://www.cisco.com/support">http://www.cisco.com/support</a> |

## Feature Information for IPv4 ACL Chaining Support

Use Cisco Feature Navigator to find information about the platform support and software image support. Cisco Feature Navigator enables you to determine which software images support a specific software release, feature set, or platform. To access Cisco Feature Navigator, go to the <https://cfng.cisco.com/> link. An account on the Cisco.com page is not required.



**Note** The following table lists the software release in which a given feature is introduced. Unless noted otherwise, subsequent releases of that software release train also support that feature.

**Table 249: Feature Information for IPv4 ACL Chaining Support**

| Feature Name    | Releases                 | Feature Information                                                                                            |
|-----------------|--------------------------|----------------------------------------------------------------------------------------------------------------|
| IP access lists | Cisco IOS XE Fuji 16.7.1 | This feature was integrated into Cisco IOS XE Fuji 16.7.1 on the Cisco cBR Series Converged Broadband Routers. |



## CHAPTER 74

# IPv6 ACL Chaining with a Common ACL

ACL Chaining, also known as Multi-Access Control List (ACL), allows you to split ACLs. This document describes how with the IPv6 ACL Chaining Support feature, you can explicitly split ACLs into common and user-specific ACLs and bind both ACLs to a target for traffic filtering on a device. In this way, the common ACLs in Ternary Content Addressable Memory (TCAM) are shared by multiple targets, thereby reducing the resource usage.

Your software release may not support all the features that are documented in this module. For the latest feature information and caveats, see the release notes for your platform and software release. The Feature Information Table at the end of this document provides information about the documented features and lists the releases in which each feature is supported.

Use Cisco Feature Navigator to find information about platform support and Cisco software image support. To access Cisco Feature Navigator, go to <http://tools.cisco.com/ITDIT/CFN/>. An account on <http://www.cisco.com/> is not required.

### Contents

- [Hardware Compatibility Matrix for the Cisco cBR Series Routers, on page 1211](#)
- [Information About IPv6 ACL Chaining with a Common ACL, on page 1213](#)
- [How to Configure IPv6 ACL Chaining with a Common ACL, on page 1213](#)
- [Configuration Examples for IPv6 ACL Chaining with a Common ACL, on page 1215](#)
- [Additional References for IPv6 ACL Chaining with a Common ACL, on page 1216](#)
- [Feature Information for IPv6 ACL Chaining with a Common ACL, on page 1217](#)

## Hardware Compatibility Matrix for the Cisco cBR Series Routers



**Note** The hardware components that are introduced in a given Cisco IOS-XE Release are supported in all subsequent releases unless otherwise specified.

Table 250: Hardware Compatibility Matrix for the Cisco cBR Series Routers

| Cisco CMTS Platform                    | Processor Engine                                                                                                                                                                                  | Interface Cards                                                                                                                                                                                                                                                                                                                                                                                                                                                                                                                                                                                                                                                                                                                                                                                 |
|----------------------------------------|---------------------------------------------------------------------------------------------------------------------------------------------------------------------------------------------------|-------------------------------------------------------------------------------------------------------------------------------------------------------------------------------------------------------------------------------------------------------------------------------------------------------------------------------------------------------------------------------------------------------------------------------------------------------------------------------------------------------------------------------------------------------------------------------------------------------------------------------------------------------------------------------------------------------------------------------------------------------------------------------------------------|
| Cisco cBR-8 Converged Broadband Router | <p><b>Cisco IOS-XE Release 16.5.1 and Later Releases</b></p> <p>Cisco cBR-8 Supervisor:</p> <ul style="list-style-type: none"> <li>• PID—CBR-SUP-250G</li> <li>• PID—CBR-CCAP-SUP-160G</li> </ul> | <p><b>Cisco IOS-XE Release 16.5.1 and Later Releases</b></p> <p>Cisco cBR-8 CCAP Line Cards:</p> <ul style="list-style-type: none"> <li>• PID—CBR-LC-8D30-16U30</li> <li>• PID—CBR-LC-8D31-16U30</li> <li>• PID—CBR-RF-PIC</li> <li>• PID—CBR-RF-PROT-PIC</li> <li>• PID—CBR-CCAP-LC-40G</li> <li>• PID—CBR-CCAP-LC-40G-R</li> <li>• PID—CBR-CCAP-LC-G2-R</li> <li>• PID—CBR-SUP-8X10G-PIC</li> <li>• PID—CBR-2X100G-PIC</li> </ul> <p>Digital PICs:</p> <ul style="list-style-type: none"> <li>• PID—CBR-DPIC-8X10G</li> <li>• PID—CBR-DPIC-2X100G</li> </ul> <p>Cisco cBR-8 Downstream PHY Module:</p> <ul style="list-style-type: none"> <li>• PID—CBR-D31-DS-MOD</li> </ul> <p>Cisco cBR-8 Upstream PHY Modules:</p> <ul style="list-style-type: none"> <li>• PID—CBR-D31-US-MOD</li> </ul> |



**Note** Do not use DPICs (8X10G and 2x100G) to forward IP traffic, as it may cause buffer exhaustion, leading to line card reload.

The only allowed traffic on a DPIC interface is DEPI, UEPI, and GCP traffic from the Cisco cBR-8 router to Remote PHY devices. Other traffic such as DHCP, SSH, and UTSC should flow via another router, since DPICs cannot be used for normal routing.



# Information About IPv6 ACL Chaining with a Common ACL

## ACL Chaining Overview

The packet filter process supports only a single Access control list (ACL) to be applied per direction and per protocol on an interface. This leads to manageability and scalability issues if there are common ACL entries needed on many interfaces. Duplicate Access control entries (ACEs) are configured for all those interfaces, and any modification to the common ACEs needs to be performed for all ACLs.

A typical ACL on the edge box for an Internet Service Provider (ISP) has two sets of ACEs:

- Common ISP specific ACEs
- Customer/interface specific ACEs

The purpose of these address blocks is to deny access to ISP's protected infrastructure networks and anti-spoofing protection by allowing only customer source address blocks. This results in configuring unique ACL per interface and most of the ACEs being common across all ACLs on a device. ACL provisioning and modification is very cumbersome, hence, any changes to the ACE impacts every target.

## IPv6 ACL Chaining with a Common ACL

With IPv6 ACL Chaining, you can configure a traffic filter with the following:

- Common ACL
- Specific ACL
- Common and Specific ACL

Each Access control list (ACL) is matched in a sequence. For example, if you have specified both the ACLs - a common and a specific ACL, the packet is first matched against the common ACL; if a match is not found, it is then matched against the specific ACL.



---

**Note** Any IPv6 ACL may be configured on a traffic filter as a common or specific ACL. However, the same ACL cannot be specified on the same traffic filter as both common and specific.

---

## How to Configure IPv6 ACL Chaining with a Common ACL

### Before you begin

IPv6 ACL chaining is configured on an interface using an extension of the existing IPv6 traffic-filter command:  
**ipv6 traffic-filter** [**common** *common-acl*] [*specific-acl*] [ **in** | **out**]



**Note** You may choose to configure either of the following:

- Only a common ACL. For example: **ipv6 traffic-filter common** *common-acl*
- Only a specific ACL. For example: **ipv6 traffic-filter** *common-acl*
- Both ACLs. For example: **ipv6 traffic-filter common** *common-acl specific-acl*

The `ipv6 traffic-filter` command is not additive. When you use the command, it replaces earlier instances of the command. For example, the command sequence: **ipv6 traffic-filter** [**common** *common-acl*] [*specific-acl*] **in** **ipv6 traffic-filter** [*specific-acl*] **in** binds a common ACL to the traffic filter, removes the common ACL and then binds a specific ACL.

## Configuring IPv6 ACL to an Interface

Perform this task to configure the interface to accept a common access control list (ACL) along with an interface-specific ACL:

### SUMMARY STEPS

1. **enable**
2. **configure terminal**
3. **interface** *type number*
4. **ipv6 traffic filter** {*common-access-list-name* {**in** | **out**}}
5. **end**

### DETAILED STEPS

|               | Command or Action                                                                                                                                              | Purpose                                                                                 |
|---------------|----------------------------------------------------------------------------------------------------------------------------------------------------------------|-----------------------------------------------------------------------------------------|
| <b>Step 1</b> | <b>enable</b><br><b>Example:</b><br>Device> enable                                                                                                             | Enables privileged EXEC mode. Enter your password if prompted.                          |
| <b>Step 2</b> | <b>configure terminal</b><br><b>Example:</b><br>Device# configure terminal                                                                                     | Enters global configuration mode.                                                       |
| <b>Step 3</b> | <b>interface</b> <i>type number</i><br><b>Example:</b><br>Device(config)# interface TenGigabitEthernet4/1/0                                                    | Specifies the interface type and number, and enters interface configuration mode.       |
| <b>Step 4</b> | <b>ipv6 traffic filter</b> { <i>common-access-list-name</i> { <b>in</b>   <b>out</b> }}<br><b>Example:</b><br>Device(config)# ipv6 traffic-filter outbound out | Applies the specified IPv6 access list to the interface specified in the previous step. |

|        | Command or Action                                       | Purpose                                                                      |
|--------|---------------------------------------------------------|------------------------------------------------------------------------------|
| Step 5 | <b>end</b><br><b>Example:</b><br>Device(config-if)# end | (Optional) Exits the configuration mode and returns to privileged EXEC mode. |

## Configuration Examples for IPv6 ACL Chaining with a Common ACL

You may configure the following combinations in no particular order:

- A common ACL, for example: **ipv6 traffic-filter common common-acl in**
- A specific ACL, for example: **ipv6 traffic-filter specific-acl in**
- Both ACLs, for example: **ipv6 traffic-filter common common-acl specific-acl in**

### Example: Configuring an Interface to Accept a Common ACL

This example shows how to replace an access control list (ACL) configured on the interface without explicitly deleting the ACL:

```
interface TenGigabitEthernet4/1/0
ipv6 access-group common C_acl ACL1 in
end
replace interface acl ACL1 by ACL2
interface TenGigabitEthernet4/1/0
ipv6 access-group common C_acl ACL2 in
end
```

This example shows how to delete a common ACL from an interface. A common ACL cannot be replaced on interfaces without deleting it explicitly from the interface.

```
interface TenGigabitEthernet4/1/0
ipv6 access-group common C_acl1 ACL1 in
end
change the common acl to C_acl2
interface TenGigabitEthernet4/1/0
no ipv6 access-group common C_acl1 ACL1 in
end
interface TenGigabitEthernet4/1/0
ipv6 access-group common C_acl2 ACL1 in
end
```



**Note** When reconfiguring a common ACL, you must ensure that no other interface on the line card is attached to the common ACL.



**Note** If both common ACL and interface ACL are attached to an interface and only one of the above is reconfigured on the interface, then the other is removed automatically.

This example shows how to remove the interface ACL:

```
interface TenGigabitEthernet4/1/0
ipv6 access-group common C_acl1 ACL1 in
end
```

## Additional References for IPv6 ACL Chaining with a Common ACL

### Related Documents

| Related Topic             | Document Title                                                                                                                                                                                                                                                                                                                                                               |
|---------------------------|------------------------------------------------------------------------------------------------------------------------------------------------------------------------------------------------------------------------------------------------------------------------------------------------------------------------------------------------------------------------------|
| IPv4 ACL Chaining Support | <a href="#">Security Configuration Guide: Access Control Lists, Cisco IOS XE Release 3S</a>                                                                                                                                                                                                                                                                                  |
| Security commands         | <ul style="list-style-type: none"> <li>• <a href="#">Cisco IOS Security Command Reference: Commands A to C</a></li> <li>• <a href="#">Cisco IOS Security Command Reference: Commands D to L</a></li> <li>• <a href="#">Cisco IOS Security Command Reference: Commands M to R</a></li> <li>• <a href="#">Cisco IOS Security Command Reference: Commands S to Z</a></li> </ul> |

### Technical Assistance

| Description                                                                                                                                                                                                                                                                                                                                                                                                                                                                                                                                                             | Link                                                                    |
|-------------------------------------------------------------------------------------------------------------------------------------------------------------------------------------------------------------------------------------------------------------------------------------------------------------------------------------------------------------------------------------------------------------------------------------------------------------------------------------------------------------------------------------------------------------------------|-------------------------------------------------------------------------|
| <p>The Cisco Support website provides extensive online resources, including documentation and tools for troubleshooting and resolving technical issues with Cisco products and technologies.</p> <p>To receive security and technical information about your products, you can subscribe to various services, such as the Product Alert Tool (accessed from Field Notices), the Cisco Technical Services Newsletter, and Really Simple Syndication (RSS) Feeds.</p> <p>Access to most tools on the Cisco Support website requires a Cisco.com user ID and password.</p> | <a href="http://www.cisco.com/support">http://www.cisco.com/support</a> |

## Feature Information for IPv6 ACL Chaining with a Common ACL

Use Cisco Feature Navigator to find information about the platform support and software image support. Cisco Feature Navigator enables you to determine which software images support a specific software release, feature set, or platform. To access Cisco Feature Navigator, go to the <https://cfng.cisco.com/> link. An account on the Cisco.com page is not required.



**Note** The following table lists the software release in which a given feature is introduced. Unless noted otherwise, subsequent releases of that software release train also support that feature.

*Table 251: Feature Information for IPv6 ACL Chaining with a Common ACL*

| Feature Name      | Releases                 | Feature Information                                                                                            |
|-------------------|--------------------------|----------------------------------------------------------------------------------------------------------------|
| IPv6 access lists | Cisco IOS XE Fuji 16.7.1 | This feature was integrated into Cisco IOS XE Fuji 16.7.1 on the Cisco cBR Series Converged Broadband Routers. |





## CHAPTER 75

# Commented IP Access List Entries

---

The Commented IP Access List Entries feature allows you to include comments or remarks about **deny** or **permit** conditions in any IP access list. These remarks make access lists easier for network administrators to understand. Each remark is limited to 100 characters in length.

This module provides information about the Commented IP Access List Entries feature.

Your software release may not support all the features that are documented in this module. For the latest feature information and caveats, see the release notes for your platform and software release. The Feature Information Table at the end of this document provides information about the documented features and lists the releases in which each feature is supported.

Use Cisco Feature Navigator to find information about platform support and Cisco software image support. To access Cisco Feature Navigator, go to <http://tools.cisco.com/ITDIT/CFN/>. An account on <http://www.cisco.com/> is not required.

### Contents

- [Hardware Compatibility Matrix for the Cisco cBR Series Routers, on page 1219](#)
- [Information About Commented IP Access List Entries, on page 1221](#)
- [How to Configure Commented IP Access List Entries, on page 1222](#)
- [Additional References for Commented IP Access List Entries, on page 1223](#)
- [Feature Information for Commented IP Access List Entries, on page 1223](#)

## Hardware Compatibility Matrix for the Cisco cBR Series Routers



---

**Note** The hardware components that are introduced in a given Cisco IOS-XE Release are supported in all subsequent releases unless otherwise specified.

---

Table 252: Hardware Compatibility Matrix for the Cisco cBR Series Routers

| Cisco CMTS Platform                    | Processor Engine                                                                                                                                                                                  | Interface Cards                                                                                                                                                                                                                                                                                                                                                                                                                                                                                                                                                                                                                                                                                                                                                                                 |
|----------------------------------------|---------------------------------------------------------------------------------------------------------------------------------------------------------------------------------------------------|-------------------------------------------------------------------------------------------------------------------------------------------------------------------------------------------------------------------------------------------------------------------------------------------------------------------------------------------------------------------------------------------------------------------------------------------------------------------------------------------------------------------------------------------------------------------------------------------------------------------------------------------------------------------------------------------------------------------------------------------------------------------------------------------------|
| Cisco cBR-8 Converged Broadband Router | <p><b>Cisco IOS-XE Release 16.5.1 and Later Releases</b></p> <p>Cisco cBR-8 Supervisor:</p> <ul style="list-style-type: none"> <li>• PID—CBR-SUP-250G</li> <li>• PID—CBR-CCAP-SUP-160G</li> </ul> | <p><b>Cisco IOS-XE Release 16.5.1 and Later Releases</b></p> <p>Cisco cBR-8 CCAP Line Cards:</p> <ul style="list-style-type: none"> <li>• PID—CBR-LC-8D30-16U30</li> <li>• PID—CBR-LC-8D31-16U30</li> <li>• PID—CBR-RF-PIC</li> <li>• PID—CBR-RF-PROT-PIC</li> <li>• PID—CBR-CCAP-LC-40G</li> <li>• PID—CBR-CCAP-LC-40G-R</li> <li>• PID—CBR-CCAP-LC-G2-R</li> <li>• PID—CBR-SUP-8X10G-PIC</li> <li>• PID—CBR-2X100G-PIC</li> </ul> <p>Digital PICs:</p> <ul style="list-style-type: none"> <li>• PID—CBR-DPIC-8X10G</li> <li>• PID—CBR-DPIC-2X100G</li> </ul> <p>Cisco cBR-8 Downstream PHY Module:</p> <ul style="list-style-type: none"> <li>• PID—CBR-D31-DS-MOD</li> </ul> <p>Cisco cBR-8 Upstream PHY Modules:</p> <ul style="list-style-type: none"> <li>• PID—CBR-D31-US-MOD</li> </ul> |



**Note** Do not use DPICs (8X10G and 2x100G) to forward IP traffic, as it may cause buffer exhaustion, leading to line card reload.

The only allowed traffic on a DPIC interface is DEPI, UEPI, and GCP traffic from the Cisco cBR-8 router to Remote PHY devices. Other traffic such as DHCP, SSH, and UTSC should flow via another router, since DPICs cannot be used for normal routing.



# Information About Commented IP Access List Entries

## Benefits of IP Access Lists

Access control lists (ACLs) perform packet filtering to control the flow of packets through a network. Packet filtering can restrict the access of users and devices to a network, providing a measure of security. Access lists can save network resources by reducing traffic. The benefits of using access lists are as follows:

- Authenticate incoming rsh and rcp requests—Access lists can simplify the identification of local users, remote hosts, and remote users in an authentication database that is configured to control access to a device. The authentication database enables Cisco software to receive incoming remote shell (rsh) and remote copy (rcp) protocol requests.
- Block unwanted traffic or users—Access lists can filter incoming or outgoing packets on an interface, thereby controlling access to a network based on source addresses, destination addresses, or user authentication. You can also use access lists to determine the types of traffic that are forwarded or blocked at device interfaces. For example, you can use access lists to permit e-mail traffic to be routed through a network and to block all Telnet traffic from entering the network.
- Control access to vty—Access lists on an inbound vty (Telnet) can control who can access the lines to a device. Access lists on an outbound vty can control the destinations that the lines from a device can reach.
- Identify or classify traffic for QoS features—Access lists provide congestion avoidance by setting the IP precedence for Weighted Random Early Detection (WRED) and committed access rate (CAR). Access lists also provide congestion management for class-based weighted fair queueing (CBWFQ), priority queueing, and custom queueing.
- Limit debug command output—Access lists can limit debug output based on an IP address or a protocol.
- Provide bandwidth control—Access lists on a slow link can prevent excess traffic on a network.
- Provide NAT control—Access lists can control which addresses are translated by Network Address Translation (NAT).
- Reduce the chance of DoS attacks—Access lists reduce the chance of denial-of-service (DoS) attacks. Specify IP source addresses to control traffic from hosts, networks, or users from accessing your network. Configure the TCP Intercept feature to can prevent servers from being flooded with requests for connection.
- Restrict the content of routing updates—Access lists can control routing updates that are sent, received, or redistributed in networks.
- Trigger dial-on-demand calls—Access lists can enforce dial and disconnect criteria.

## Access List Remarks

You can include comments or remarks about entries in any IP access list. An access list remark is an optional remark before or after an access list entry that describes the entry so that you do not have to interpret the purpose of the entry. Each remark is limited to 100 characters in length.

The remark can go before or after a **permit** or **deny** statement. Be consistent about where you add remarks. Users may be confused if some remarks precede the associated **permit** or **deny** statements and some remarks follow the associated statements.

The following is an example of a remark that describes function of the subsequent **deny** statement:

```
ip access-list extended telnetting
 remark Do not allow host1 subnet to telnet out
 deny tcp host 172.16.2.88 any eq telnet
```

## How to Configure Commented IP Access List Entries

### Writing Remarks in a Named or Numbered Access List

You can use a named or numbered access list configuration. You must apply the access list to an interface or terminal line after the access list is created for the configuration to work.

#### SUMMARY STEPS

1. **enable**
2. **configure terminal**
3. **ip access-list** {standard | extended} {name | number}
4. **remark** remark
5. **deny** protocol host host-address any eq port
6. **end**

#### DETAILED STEPS

|               | Command or Action                                                                                                                    | Purpose                                                                                                                                                                                    |
|---------------|--------------------------------------------------------------------------------------------------------------------------------------|--------------------------------------------------------------------------------------------------------------------------------------------------------------------------------------------|
| <b>Step 1</b> | <b>enable</b><br><b>Example:</b><br>Device> enable                                                                                   | Enables privileged EXEC mode.<br><ul style="list-style-type: none"><li>• Enter your password if prompted.</li></ul>                                                                        |
| <b>Step 2</b> | <b>configure terminal</b><br><b>Example:</b><br>Device# configure terminal                                                           | Enters global configuration mode.                                                                                                                                                          |
| <b>Step 3</b> | <b>ip access-list</b> {standard   extended} {name   number}<br><b>Example:</b><br>Device(config)# ip access-list extended telnetting | Identifies the access list by a name or number and enters extended named access list configuration mode.                                                                                   |
| <b>Step 4</b> | <b>remark</b> remark<br><b>Example:</b><br>Device(config-ext-nacl)# remark Do not allow host1 subnet to telnet out                   | Adds a remark for an entry in a named IP access list.<br><ul style="list-style-type: none"><li>• The remark indicates the purpose of the <b>permit</b> or <b>deny</b> statement.</li></ul> |

|        | Command or Action                                                                                                                                    | Purpose                                                                              |
|--------|------------------------------------------------------------------------------------------------------------------------------------------------------|--------------------------------------------------------------------------------------|
| Step 5 | <b>deny protocol host host-address any eq port</b><br><b>Example:</b><br><pre>Device(config-ext-nacl)# deny tcp host 172.16.2.88 any eq telnet</pre> | Sets conditions in a named IP access list that denies packets.                       |
| Step 6 | <b>end</b><br><b>Example:</b><br><pre>Device(config-ext-nacl)# end</pre>                                                                             | Exits extended named access list configuration mode and enters privileged EXEC mode. |

## Additional References for Commented IP Access List Entries

### Related Documents

| Related Topic     | Document Title                                                                                                                                                                                                                                                                                                                                                               |
|-------------------|------------------------------------------------------------------------------------------------------------------------------------------------------------------------------------------------------------------------------------------------------------------------------------------------------------------------------------------------------------------------------|
| Security commands | <ul style="list-style-type: none"> <li>• <a href="#">Cisco IOS Security Command Reference: Commands A to C</a></li> <li>• <a href="#">Cisco IOS Security Command Reference: Commands D to L</a></li> <li>• <a href="#">Cisco IOS Security Command Reference: Commands M to R</a></li> <li>• <a href="#">Cisco IOS Security Command Reference: Commands S to Z</a></li> </ul> |

### Technical Assistance

| Description                                                                                                                                                                                                                                                                                                                                                                           | Link                                                                                                              |
|---------------------------------------------------------------------------------------------------------------------------------------------------------------------------------------------------------------------------------------------------------------------------------------------------------------------------------------------------------------------------------------|-------------------------------------------------------------------------------------------------------------------|
| The Cisco Support and Documentation website provides online resources to download documentation, software, and tools. Use these resources to install and configure the software and to troubleshoot and resolve technical issues with Cisco products and technologies. Access to most tools on the Cisco Support and Documentation website requires a Cisco.com user ID and password. | <a href="http://www.cisco.com/cisco/web/support/index.html">http://www.cisco.com/cisco/web/support/index.html</a> |

## Feature Information for Commented IP Access List Entries

Use Cisco Feature Navigator to find information about the platform support and software image support. Cisco Feature Navigator enables you to determine which software images support a specific software release, feature set, or platform. To access Cisco Feature Navigator, go to the <https://cfng.cisco.com/> link. An account on the Cisco.com page is not required.



**Note** The following table lists the software release in which a given feature is introduced. Unless noted otherwise, subsequent releases of that software release train also support that feature.

**Table 253: Feature Information for Commented IP Access List Entries**

| <b>Feature Name</b> | <b>Releases</b>          | <b>Feature Information</b>                                                                                     |
|---------------------|--------------------------|----------------------------------------------------------------------------------------------------------------|
| IP Access Lists     | Cisco IOS XE Fuji 16.7.1 | This feature was integrated into Cisco IOS XE Fuji 16.7.1 on the Cisco cBR Series Converged Broadband Routers. |



## CHAPTER 76

# Standard IP Access List Logging

The Standard IP Access List Logging feature provides the ability to log messages about packets that are permitted or denied by a standard IP access list. Any packet that matches the access list logs an information message about the packet at the device console.

This module provides information about standard IP access list logging.

Your software release may not support all the features that are documented in this module. For the latest feature information and caveats, see the release notes for your platform and software release. The Feature Information Table at the end of this document provides information about the documented features and lists the releases in which each feature is supported.

Use Cisco Feature Navigator to find information about platform support and Cisco software image support. To access Cisco Feature Navigator, go to <http://tools.cisco.com/ITDIT/CFN/>. An account on <http://www.cisco.com/> is not required.

### Contents

- [Hardware Compatibility Matrix for the Cisco cBR Series Routers, on page 1225](#)
- [Restrictions for Standard IP Access List Logging, on page 1226](#)
- [Information About Standard IP Access List Logging, on page 1227](#)
- [How to Configure Standard IP Access List Logging, on page 1227](#)
- [Configuration Examples for Standard IP Access List Logging, on page 1229](#)
- [Additional References for Standard IP Access List Logging, on page 1230](#)
- [Feature Information for Standard IP Access List Logging, on page 1230](#)

## Hardware Compatibility Matrix for the Cisco cBR Series Routers



**Note** The hardware components that are introduced in a given Cisco IOS-XE Release are supported in all subsequent releases unless otherwise specified.

Table 254: Hardware Compatibility Matrix for the Cisco cBR Series Routers

| Cisco CMTS Platform                    | Processor Engine                                                                                                                                                                                  | Interface Cards                                                                                                                                                                                                                                                                                                                                                                                                                                                                                                                                                                                                                                                                                                                                                                                 |
|----------------------------------------|---------------------------------------------------------------------------------------------------------------------------------------------------------------------------------------------------|-------------------------------------------------------------------------------------------------------------------------------------------------------------------------------------------------------------------------------------------------------------------------------------------------------------------------------------------------------------------------------------------------------------------------------------------------------------------------------------------------------------------------------------------------------------------------------------------------------------------------------------------------------------------------------------------------------------------------------------------------------------------------------------------------|
| Cisco cBR-8 Converged Broadband Router | <p><b>Cisco IOS-XE Release 16.5.1 and Later Releases</b></p> <p>Cisco cBR-8 Supervisor:</p> <ul style="list-style-type: none"> <li>• PID—CBR-SUP-250G</li> <li>• PID—CBR-CCAP-SUP-160G</li> </ul> | <p><b>Cisco IOS-XE Release 16.5.1 and Later Releases</b></p> <p>Cisco cBR-8 CCAP Line Cards:</p> <ul style="list-style-type: none"> <li>• PID—CBR-LC-8D30-16U30</li> <li>• PID—CBR-LC-8D31-16U30</li> <li>• PID—CBR-RF-PIC</li> <li>• PID—CBR-RF-PROT-PIC</li> <li>• PID—CBR-CCAP-LC-40G</li> <li>• PID—CBR-CCAP-LC-40G-R</li> <li>• PID—CBR-CCAP-LC-G2-R</li> <li>• PID—CBR-SUP-8X10G-PIC</li> <li>• PID—CBR-2X100G-PIC</li> </ul> <p>Digital PICs:</p> <ul style="list-style-type: none"> <li>• PID—CBR-DPIC-8X10G</li> <li>• PID—CBR-DPIC-2X100G</li> </ul> <p>Cisco cBR-8 Downstream PHY Module:</p> <ul style="list-style-type: none"> <li>• PID—CBR-D31-DS-MOD</li> </ul> <p>Cisco cBR-8 Upstream PHY Modules:</p> <ul style="list-style-type: none"> <li>• PID—CBR-D31-US-MOD</li> </ul> |



**Note** Do not use DPICs (8X10G and 2x100G) to forward IP traffic, as it may cause buffer exhaustion, leading to line card reload.

The only allowed traffic on a DPIC interface is DEPI, UEPI, and GCP traffic from the Cisco cBR-8 router to Remote PHY devices. Other traffic such as DHCP, SSH, and UTSC should flow via another router, since DPICs cannot be used for normal routing.

## Restrictions for Standard IP Access List Logging

IP access list logging is supported only for routed interfaces or router access control lists (ACLs).

# Information About Standard IP Access List Logging

## Standard IP Access List Logging

The Standard IP Access List Logging feature provides the ability to log messages about packets that are permitted or denied by a standard IP access list. Any packet that matches the access list causes an information log message about the packet to be sent to the device console. The log level of messages that are printed to the device console is controlled by the **logging console** command.

The first packet that the access list inspects triggers the access list to log a message at the device console. Subsequent packets are collected over 5-minute intervals before they are displayed or logged. Log messages include information about the access list number, the source IP address of packets, the number of packets from the same source that were permitted or denied in the previous 5-minute interval, and whether a packet was permitted or denied. You can also monitor the number of packets that are permitted or denied by a particular access list, including the source address of each packet.

## How to Configure Standard IP Access List Logging

### Creating a Standard IP Access List Using Numbers

#### SUMMARY STEPS

1. **enable**
2. **configure terminal**
3. **access-list** *access-list-number* {deny | permit} **host** *address* [log]
4. **access-list** *access-list-number* {deny | permit} **any** [log]
5. **interface** *type number*
6. **ip access-group** *access-list-number* {in | out}
7. **end**

#### DETAILED STEPS

|        | Command or Action                                                                             | Purpose                                                                                                       |
|--------|-----------------------------------------------------------------------------------------------|---------------------------------------------------------------------------------------------------------------|
| Step 1 | <b>enable</b><br><b>Example:</b><br>Device> enable                                            | Enables privileged EXEC mode.<br><br>• Enter your password if prompted.                                       |
| Step 2 | <b>configure terminal</b><br><b>Example:</b><br>Device# configure terminal                    | Enters global configuration mode.                                                                             |
| Step 3 | <b>access-list</b> <i>access-list-number</i> {deny   permit} <b>host</b> <i>address</i> [log] | Defines a standard numbered IP access list using a source address and wildcard, and configures the logging of |

|               | Command or Action                                                                                                                         | Purpose                                                                                                                                                                                                                                        |
|---------------|-------------------------------------------------------------------------------------------------------------------------------------------|------------------------------------------------------------------------------------------------------------------------------------------------------------------------------------------------------------------------------------------------|
|               | <b>Example:</b><br>Device(config)# access-list 1 permit host 10.1.1.1 log                                                                 | informational messages about packets that match the access list entry at the device console.                                                                                                                                                   |
| <b>Step 4</b> | <b>access-list</b> <i>access-list-number</i> {deny   permit} any [log]<br><b>Example:</b><br>Device(config)# access-list 1 permit any log | Defines a standard numbered IP access list by using an abbreviation for the source and source mask 0.0.0.0 255.255.255.255.                                                                                                                    |
| <b>Step 5</b> | <b>interface</b> <i>type number</i><br><b>Example:</b><br>Device(config)# interface TenGigabitEthernet4/1/0                               | Configures an interface and enters interface configuration mode.                                                                                                                                                                               |
| <b>Step 6</b> | <b>ip access-group</b> <i>access-list-number</i> {in   out}<br><b>Example:</b><br>Device(config-if)# ip access-group 1 in                 | Applies the specified numbered access list to the incoming or outgoing interface. <ul style="list-style-type: none"> <li>• When you filter based on source addresses, you typically apply the access list to an incoming interface.</li> </ul> |
| <b>Step 7</b> | <b>end</b><br><b>Example:</b><br>Device(config-if)# end                                                                                   | Exits interface configuration mode and enters privileged EXEC mode.                                                                                                                                                                            |

## Creating a Standard IP Access List Using Names

### SUMMARY STEPS

1. enable
2. configure terminal
3. ip access-list standard *name*
4. {deny | permit} {host *address* | any} log
5. exit
6. interface *type number*
7. ip access-group *access-list-name* {in | out}
8. end

### DETAILED STEPS

|               | Command or Action                                                          | Purpose                                                                                                            |
|---------------|----------------------------------------------------------------------------|--------------------------------------------------------------------------------------------------------------------|
| <b>Step 1</b> | <b>enable</b><br><b>Example:</b><br>Device> enable                         | Enables privileged EXEC mode. <ul style="list-style-type: none"> <li>• Enter your password if prompted.</li> </ul> |
| <b>Step 2</b> | <b>configure terminal</b><br><b>Example:</b><br>Device# configure terminal | Enters global configuration mode.                                                                                  |



|        | Command or Action                                                                                                                 | Purpose                                                                                                                                                                                                                                                   |
|--------|-----------------------------------------------------------------------------------------------------------------------------------|-----------------------------------------------------------------------------------------------------------------------------------------------------------------------------------------------------------------------------------------------------------|
| Step 3 | <b>ip access-list standard</b> <i>name</i><br><b>Example:</b><br>Device(config)# ip access-list standard acl1                     | Defines a standard IP access list and enters standard named access list configuration mode.                                                                                                                                                               |
| Step 4 | <b>{deny   permit} {host address   any} log</b><br><b>Example:</b><br>Device(config-std-nacl)# permit host 10.1.1.1 log           | Sets conditions in a named IP access list that will deny packets from entering a network or permit packets to enter a network, and configures the logging of informational messages about packets that match the access list entry at the device console. |
| Step 5 | <b>exit</b><br><b>Example:</b><br>Device(config-std-nacl)# exit                                                                   | Exits standard named access list configuration mode and enters global configuration mode.                                                                                                                                                                 |
| Step 6 | <b>interface</b> <i>type number</i><br><b>Example:</b><br>Device(config)# interface TenGigabitEthernet4/1/0                       | Configures an interface and enters interface configuration mode.                                                                                                                                                                                          |
| Step 7 | <b>ip access-group</b> <i>access-list-name</i> <b>{in   out}</b><br><b>Example:</b><br>Device(config-if)# ip access-group acl1 in | Applies the specified access list to the incoming or outgoing interface. <ul style="list-style-type: none"> <li>When you filter based on source addresses, you typically apply the access list to an incoming interface.</li> </ul>                       |
| Step 8 | <b>end</b><br><b>Example:</b><br>Device(config-if)# end                                                                           | Exits interface configuration mode and enters privileged EXEC mode.                                                                                                                                                                                       |

## Configuration Examples for Standard IP Access List Logging

### Example: Limiting Debug Output

The following sample configuration uses an access list to limit the **debug** command output. Limiting the **debug** output restricts the volume of data to what you are interested in, saving you time and resources.

```
Device(config)# ip access-list acl1
Device(config-std-nacl)# remark Displays only advertisements for LDP peer in acl1
Device(config-std-nacl)# permit host 10.0.0.44
```

```
Device# debug mpls ldp advertisements peer-acl acl1
```

```
tagcon: peer 10.0.0.44:0 (pp 0x60E105BC): advertise 172.17.0.33
tagcon: peer 10.0.0.44:0 (pp 0x60E105BC): advertise 172.16.0.31
tagcon: peer 10.0.0.44:0 (pp 0x60E105BC): advertise 172.22.0.33
tagcon: peer 10.0.0.44:0 (pp 0x60E105BC): advertise 192.168.0.1
tagcon: peer 10.0.0.44:0 (pp 0x60E105BC): advertise 192.168.0.3
tagcon: peer 10.0.0.44:0 (pp 0x60E105BC): advertise 192.168.1.33
```

## Additional References for Standard IP Access List Logging

### Related Documents

| Related Topic     | Document Title                                                                                                                                                                                                                                                                                                                                                               |
|-------------------|------------------------------------------------------------------------------------------------------------------------------------------------------------------------------------------------------------------------------------------------------------------------------------------------------------------------------------------------------------------------------|
| Security commands | <ul style="list-style-type: none"> <li>• <a href="#">Cisco IOS Security Command Reference: Commands A to C</a></li> <li>• <a href="#">Cisco IOS Security Command Reference: Commands D to L</a></li> <li>• <a href="#">Cisco IOS Security Command Reference: Commands M to R</a></li> <li>• <a href="#">Cisco IOS Security Command Reference: Commands S to Z</a></li> </ul> |

### Technical Assistance

| Description                                                                                                                                                                                                                                                                                                                                                                           | Link                                                                                                              |
|---------------------------------------------------------------------------------------------------------------------------------------------------------------------------------------------------------------------------------------------------------------------------------------------------------------------------------------------------------------------------------------|-------------------------------------------------------------------------------------------------------------------|
| The Cisco Support and Documentation website provides online resources to download documentation, software, and tools. Use these resources to install and configure the software and to troubleshoot and resolve technical issues with Cisco products and technologies. Access to most tools on the Cisco Support and Documentation website requires a Cisco.com user ID and password. | <a href="http://www.cisco.com/cisco/web/support/index.html">http://www.cisco.com/cisco/web/support/index.html</a> |

## Feature Information for Standard IP Access List Logging

Use Cisco Feature Navigator to find information about the platform support and software image support. Cisco Feature Navigator enables you to determine which software images support a specific software release, feature set, or platform. To access Cisco Feature Navigator, go to the <https://cfng.cisco.com/> link. An account on the Cisco.com page is not required.



**Note** The following table lists the software release in which a given feature is introduced. Unless noted otherwise, subsequent releases of that software release train also support that feature.

*Table 255: Feature Information for Standard IP Access List Logging*

| Feature Name    | Releases                 | Feature Information                                                                                            |
|-----------------|--------------------------|----------------------------------------------------------------------------------------------------------------|
| IP Access Lists | Cisco IOS XE Fuji 16.7.1 | This feature was integrated into Cisco IOS XE Fuji 16.7.1 on the Cisco cBR Series Converged Broadband Routers. |



## CHAPTER 77

# IP Access List Entry Sequence Numbering

The IP Access List Entry Sequence Numbering feature allows you to apply sequence numbers to **permit** or **deny** statements as well as reorder, add, or remove such statements from a named IP access list. The IP Access List Entry Sequence Numbering feature makes revising IP access lists much easier. Prior to this feature, you could add access list entries to the end of an access list only; therefore, needing to add statements anywhere except at the end of a named IP access list required reconfiguring the entire access list.

Your software release may not support all the features that are documented in this module. For the latest feature information and caveats, see the release notes for your platform and software release. The Feature Information Table at the end of this document provides information about the documented features and lists the releases in which each feature is supported.

Use Cisco Feature Navigator to find information about platform support and Cisco software image support. To access Cisco Feature Navigator, go to <http://tools.cisco.com/ITDIT/CFN/>. An account on <http://www.cisco.com/> is not required.

### Contents

- [Hardware Compatibility Matrix for the Cisco cBR Series Routers, on page 1231](#)
- [Restrictions for IP Access List Entry Sequence Numbering, on page 1232](#)
- [Information About IP Access List Entry Sequence Numbering, on page 1233](#)
- [How to Use Sequence Numbers in an IP Access List, on page 1237](#)
- [Configuration Examples for IP Access List Entry Sequence Numbering, on page 1240](#)
- [Additional References, on page 1242](#)
- [Feature Information for IP Access List Entry Sequence Numbering , on page 1242](#)

## Hardware Compatibility Matrix for the Cisco cBR Series Routers



**Note** The hardware components that are introduced in a given Cisco IOS-XE Release are supported in all subsequent releases unless otherwise specified.

Table 256: Hardware Compatibility Matrix for the Cisco cBR Series Routers

| Cisco CMTS Platform                    | Processor Engine                                                                                                                                                                                  | Interface Cards                                                                                                                                                                                                                                                                                                                                                                                                                                                                                                                                                                                                                                                                                                                                                                                 |
|----------------------------------------|---------------------------------------------------------------------------------------------------------------------------------------------------------------------------------------------------|-------------------------------------------------------------------------------------------------------------------------------------------------------------------------------------------------------------------------------------------------------------------------------------------------------------------------------------------------------------------------------------------------------------------------------------------------------------------------------------------------------------------------------------------------------------------------------------------------------------------------------------------------------------------------------------------------------------------------------------------------------------------------------------------------|
| Cisco cBR-8 Converged Broadband Router | <p><b>Cisco IOS-XE Release 16.5.1 and Later Releases</b></p> <p>Cisco cBR-8 Supervisor:</p> <ul style="list-style-type: none"> <li>• PID—CBR-SUP-250G</li> <li>• PID—CBR-CCAP-SUP-160G</li> </ul> | <p><b>Cisco IOS-XE Release 16.5.1 and Later Releases</b></p> <p>Cisco cBR-8 CCAP Line Cards:</p> <ul style="list-style-type: none"> <li>• PID—CBR-LC-8D30-16U30</li> <li>• PID—CBR-LC-8D31-16U30</li> <li>• PID—CBR-RF-PIC</li> <li>• PID—CBR-RF-PROT-PIC</li> <li>• PID—CBR-CCAP-LC-40G</li> <li>• PID—CBR-CCAP-LC-40G-R</li> <li>• PID—CBR-CCAP-LC-G2-R</li> <li>• PID—CBR-SUP-8X10G-PIC</li> <li>• PID—CBR-2X100G-PIC</li> </ul> <p>Digital PICs:</p> <ul style="list-style-type: none"> <li>• PID—CBR-DPIC-8X10G</li> <li>• PID—CBR-DPIC-2X100G</li> </ul> <p>Cisco cBR-8 Downstream PHY Module:</p> <ul style="list-style-type: none"> <li>• PID—CBR-D31-DS-MOD</li> </ul> <p>Cisco cBR-8 Upstream PHY Modules:</p> <ul style="list-style-type: none"> <li>• PID—CBR-D31-US-MOD</li> </ul> |



**Note** Do not use DPICs (8X10G and 2x100G) to forward IP traffic, as it may cause buffer exhaustion, leading to line card reload.

The only allowed traffic on a DPIC interface is DEPI, UEPI, and GCP traffic from the Cisco cBR-8 router to Remote PHY devices. Other traffic such as DHCP, SSH, and UTSC should flow via another router, since DPICs cannot be used for normal routing.

## Restrictions for IP Access List Entry Sequence Numbering

- This feature does not support dynamic, reflexive, or firewall access lists.

- This feature does not support old-style numbered access lists, which existed before named access lists. Keep in mind that you can name an access list with a number, so numbers are allowed when they are entered in the standard or extended named access list (NACL) configuration mode.

# Information About IP Access List Entry Sequence Numbering

## Purpose of IP Access Lists

Access lists perform packet filtering to control which packets move through the network and where. Such control can help limit network traffic and restrict the access of users and devices to the network. Access lists have many uses, and therefore many commands accept a reference to an access list in their command syntax. Access lists can be used to do the following:

- Filter incoming packets on an interface.
- Filter outgoing packets on an interface.
- Restrict the contents of routing updates.
- Limit debug output based on an address or protocol.
- Control virtual terminal line access.
- Identify or classify traffic for advanced features, such as congestion avoidance, congestion management, and priority and custom queuing.
- Trigger dial-on-demand routing (DDR) calls.

## How an IP Access List Works

An access list is a sequential list consisting of a permit statement and a deny statement that apply to IP addresses and possibly upper-layer IP protocols. The access list has a name by which it is referenced. Many software commands accept an access list as part of their syntax.

An access list can be configured and named, but it is not in effect until the access list is referenced by a command that accepts an access list. Multiple commands can reference the same access list. An access list can control traffic arriving at the device or leaving the device, but not traffic originating at the device.

## IP Access List Process and Rules

- The software tests the source or destination address or the protocol of each packet being filtered against the conditions in the access list, one condition (**permit** or **deny** statement) at a time.
- If a packet does not match an access list statement, the packet is then tested against the next statement in the list.
- If a packet and an access list statement match, the rest of the statements in the list are skipped and the packet is permitted or denied as specified in the matched statement. The first entry that the packet matches determines whether the software permits or denies the packet. That is, after the first match, no subsequent entries are considered.

- If the access list denies the address or protocol, the software discards the packet and returns an Internet Control Message Protocol (ICMP) Host Unreachable message.
- If no conditions match, the packet is dropped. This is because each access list ends with an unwritten or implicit **deny** statement. That is, if the packet has not been permitted by the time it was tested against each statement, it is denied.
- Because the software stops testing conditions after the first match, the order of the conditions is critical. The same **permit** or **deny** statements specified in a different order could result in a packet being passed under one circumstance and denied in another circumstance.
- If an access list is referenced by name in a command, but the access list does not exist, all packets pass.
- Only one access list per interface, per protocol, per direction is allowed.
- Inbound access lists process packets arriving at the device. Incoming packets are processed before being routed to an outbound interface. An inbound access list is efficient because it saves the overhead of routing lookups if the packet is to be discarded because it is denied by the filtering tests. If the packet is permitted by the tests, it is then processed for routing. For inbound lists, **permit** means continue to process the packet after receiving it on an inbound interface; **deny** means discard the packet.
- Outbound access lists process packets before they leave the device. Incoming packets are routed to the outbound interface and then processed through the outbound access list. For outbound lists, **permit** means send it to the output buffer; **deny** means discard the packet.

## Helpful Hints for Creating IP Access Lists

The following tips will help you avoid unintended consequences and help you create more efficient, useful access lists.

- Create the access list before applying it to an interface (or elsewhere), because if you apply a nonexistent access list to an interface and then proceed to configure the access list, the first statement is put into effect, and the implicit **deny** statement that follows could cause you immediate access problems.
- Another reason to configure an access list before applying it is because an interface with an empty access list applied to it permits all traffic.
- All access lists need at least one **permit** statement; otherwise, all packets are denied and no traffic passes.
- Because the software stops testing conditions after it encounters the first match (to either a **permit** or **deny** statement), you will reduce processing time and resources if you put the statements that packets are most likely to match at the beginning of the access list. Place more frequently occurring conditions before less frequent conditions.
- Organize your access list so that more specific references in a network or subnet appear before more general ones.
- Use the statement **permit any any** if you want to allow all other packets not already denied. Using the statement **permit any any** in effect avoids denying all other packets with the implicit deny statement at the end of an access list. Do not make your first access list entry **permit any any** because all traffic will get through; no packets will reach the subsequent testing. In fact, once you specify **permit any any**, all traffic not already denied will get through.
- Although all access lists end with an implicit **deny** statement, we recommend use of an explicit **deny** statement (for example, **deny ip any any**). On most platforms, you can display the count of packets

denied by issuing the **show access-list** command, thus finding out more information about who your access list is disallowing. Only packets denied by explicit **deny** statements are counted, which is why the explicit **deny** statement will yield more complete data for you.

- While you are creating an access list or after it is created, you might want to delete an entry.
  - You cannot delete an entry from a numbered access list; trying to do so will delete the entire access list. If you need to delete an entry, you need to delete the entire access list and start over.
  - You can delete an entry from a named access list. Use the **no permit** or **no deny** command to delete the appropriate entry.
- In order to make the purpose of individual statements more scannable and easily understood at a glance, you can write a helpful remark before or after any statement by using the **remark** command.
- If you want to deny access to a particular host or network and find out if someone from that network or host is attempting to gain access, include the **log** keyword with the corresponding **deny** statement so that the packets denied from that source are logged for you.
- This hint applies to the placement of your access list. When trying to save resources, remember that an inbound access list applies the filter conditions before the routing table lookup. An outbound access list applies the filter conditions after the routing table lookup.
- Before you add new ACL statements, provide time to the parser to clean up the deletion.

## Source and Destination Addresses

Source and destination address fields in an IP packet are two typical fields on which to base an access list. Specify source addresses to control the packets being sent from certain networking devices or hosts. Specify destination addresses to control the packets being sent to certain networking devices or hosts.

## Wildcard Mask and Implicit Wildcard Mask

When comparing the address bits in an access list entry to a packet being submitted to the access list, address filtering uses wildcard masking to determine whether to check or ignore the corresponding IP address bits. By carefully setting wildcard masks, an administrator can select one or more IP addresses for permit or deny tests.

Wildcard masking for IP address bits uses the number 1 and the number 0 to specify how the software treats the corresponding IP address bits. A wildcard mask is sometimes referred to as an inverted mask because a 1 and 0 mean the opposite of what they mean in a subnet (network) mask.

- A wildcard mask bit 0 means check the corresponding bit value.
- A wildcard mask bit 1 means ignore that corresponding bit value.

If you do not supply a wildcard mask with a source or destination address in an access list statement, the software assumes a default wildcard mask of 0.0.0.0.

Unlike subnet masks, which require contiguous bits indicating network and subnet to be ones, wildcard masks allow noncontiguous bits in the mask.

## Transport Layer Information

You can filter packets based on transport layer information, such as whether the packet is a TCP, UDP, Internet Control Message Protocol (ICMP) or Internet Group Management Protocol (IGMP) packet.

## Benefits IP Access List Entry Sequence Numbering

The ability to apply sequence numbers to IP access list entries simplifies access list changes. Prior to the IP Access List Entry Sequence Numbering feature, there was no way to specify the position of an entry within an access list. If you wanted to insert an entry (statement) in the middle of an existing list, all of the entries *after* the desired position had to be removed. Then, once you added the new entry, you needed to reenter all of the entries you removed earlier. This method was cumbersome and error prone.

The IP Access List Entry Sequence Numbering feature allows you to add sequence numbers to access list entries and resequence them. When you add a new entry, you can choose the sequence number so that the entry is in a desired position in the access list. If necessary, entries currently in the access list can be resequenced (reordered) to create room to insert the new entry.

## Sequence Numbering Behavior

- For backward compatibility with previous releases, if entries with no sequence numbers are applied, the first entry is assigned a sequence number of 10, and successive entries are incremented by 10. The maximum sequence number is 2147483647. If the generated sequence number exceeds this maximum number, the following message is displayed:

```
Exceeded maximum sequence number.
```

- If you enter an entry without a sequence number, it is assigned a sequence number that is 10 greater than the last sequence number in that access list and is placed at the end of the list.
- If you enter an entry that matches an already existing entry (except for the sequence number), then no changes are made.
- If you enter a sequence number that is already present, the following error message is generated:

```
Duplicate sequence number.
```

- If a new access list is entered from global configuration mode, then sequence numbers for that access list are generated automatically.
- Entries that contain a fully qualified 32-bit host address are hashed instead of linked. And entries that define a sub-net are maintained in a linked list that is sorted by the sequence number for speed of ACL classification. When a packet is matched against a standard ACL, the source address is hashed and matched against the hash table. If no match is found, it then searches the linked list for a possible match.
- Distributed support is provided so that the sequence numbers of entries in the Route Processor (RP) and line card (LC) are always synchronized.
- From Cisco IOS XE Release 16.12, sequence numbers are nvgened. That is, the sequence numbers are saved. In the event that a system is reloaded, the configured sequence numbers are preserved.



- From Cisco IOS XE Release 16.12, remarks can be added with or without sequence number. These remarks can be added to any existing ACE and they are nvgened.
- Sequence numbers are not nvgened. That is, the sequence numbers themselves are not saved. In the event that the system is reloaded, the configured sequence numbers revert to the default sequence starting number and increment from that number. The function is provided for backward compatibility with software releases that do not support sequence numbering.
- The IP Access List Entry Sequence Numbering feature works with named standard and extended IP access lists. Because the name of an access list can be designated as a number, numbers are acceptable.

## How to Use Sequence Numbers in an IP Access List

### Sequencing Access-List Entries and Revising the Access List

This task shows how to assign sequence numbers to entries in a named IP access list and how to add or delete an entry to or from an access list. When completing this task, keep the following points in mind:

- Resequencing the access list entries is optional. The resequencing step in this task is shown as required because that is one purpose of this feature and this task demonstrates that functionality.
- In the following procedure, the **permit** command is shown in Step 5 and the **deny** command is shown in Step 6. However, that order can be reversed. Use the order that suits the need of your configuration.

#### SUMMARY STEPS

1. **enable**
2. **configure terminal**
3. **ip access-list resequence** *access-list-name starting-sequence-number increment*
4. **ip access-list** {**standard**|**extended**} *access-list-name*
5. Do one of the following:
  - *sequence-number* **permit** *source source-wildcard*
  - *sequence-number* **permit** *protocol source source-wildcard destination destination-wildcard* [**precedence** *precedence*][**tos** *tos*] [**log**] [**time-range** *time-range-name*] [**fragments**]
6. Do one of the following:
  - *sequence-number* **deny** *source source-wildcard*
  - *sequence-number* **deny** *protocol source source-wildcard destination destination-wildcard* [**precedence** *precedence*][**tos** *tos*] [**log**] [**time-range** *time-range-name*] [**fragments**]
7. Do one of the following:
  - *sequence-number* **permit** *source source-wildcard*
  - *sequence-number* **permit** *protocol source source-wildcard destination destination-wildcard* [**precedence** *precedence*][**tos** *tos*] [**log**] [**time-range** *time-range-name*] [**fragments**]
8. Do one of the following:
  - *sequence-number* **deny** *source source-wildcard*

- *sequence-number deny protocol source source-wildcard destination destination-wildcard [precedence precedence][tos tos] [log] [time-range time-range-name] [fragments]*

- Repeat Step 5 and/or Step 6 to add sequence number statements, as applicable.
- end**
- show ip access-lists** *access-list-name*

## DETAILED STEPS

|               | Command or Action                                                                                                                                                                                                                                                                                                                                                                                          | Purpose                                                                                                                                                                                                                                                                                                                                                                                                                                                                                                                                |
|---------------|------------------------------------------------------------------------------------------------------------------------------------------------------------------------------------------------------------------------------------------------------------------------------------------------------------------------------------------------------------------------------------------------------------|----------------------------------------------------------------------------------------------------------------------------------------------------------------------------------------------------------------------------------------------------------------------------------------------------------------------------------------------------------------------------------------------------------------------------------------------------------------------------------------------------------------------------------------|
| <b>Step 1</b> | <b>enable</b><br><b>Example:</b><br>Device> enable                                                                                                                                                                                                                                                                                                                                                         | Enables privileged EXEC mode. Enter your password if prompted.                                                                                                                                                                                                                                                                                                                                                                                                                                                                         |
| <b>Step 2</b> | <b>configure terminal</b><br><b>Example:</b><br>Device# configure terminal                                                                                                                                                                                                                                                                                                                                 | Enters global configuration mode.                                                                                                                                                                                                                                                                                                                                                                                                                                                                                                      |
| <b>Step 3</b> | <b>ip access-list resequence</b> <i>access-list-name</i><br><i>starting-sequence-number increment</i><br><b>Example:</b><br>Device(config)# ip access-list resequence kmdl<br>100 15                                                                                                                                                                                                                       | Resequences the specified IP access list using the starting sequence number and the increment of sequence numbers.                                                                                                                                                                                                                                                                                                                                                                                                                     |
| <b>Step 4</b> | <b>ip access-list</b> { <b>standard</b>   <b>extended</b> } <i>access-list-name</i><br><b>Example:</b><br>Device(config)# ip access-list standard kmdl                                                                                                                                                                                                                                                     | Specifies the IP access list by name and enters named access list configuration mode. <ul style="list-style-type: none"> <li>• If you specify <b>standard</b>, make sure you subsequently specify <b>permit</b> and/or <b>deny</b> statements using the standard access list syntax.</li> <li>• If you specify <b>extended</b>, make sure you subsequently specify <b>permit</b> and/or <b>deny</b> statements using the extended access list syntax.</li> </ul>                                                                       |
| <b>Step 5</b> | Do one of the following: <ul style="list-style-type: none"> <li>• <i>sequence-number permit source source-wildcard</i></li> <li>• <i>sequence-number permit protocol source source-wildcard destination destination-wildcard [precedence precedence][tos tos] [log] [time-range time-range-name] [fragments]</i></li> </ul> <b>Example:</b><br>Device (config-std-nacl) # 105 permit 10.5.5.5 0.0.0<br>255 | Specifies a permit statement in named IP access list mode. <ul style="list-style-type: none"> <li>• This access list happens to use a <b>permit</b> statement first, but a <b>deny</b> statement could appear first, depending on the order of statements you need.</li> <li>• As the prompt indicates, this access list was a standard access list. If you had specified <b>extended</b> in Step 4, the prompt for this step would be Device(config-ext-nacl) and you would use the extended <b>permit</b> command syntax.</li> </ul> |

|                | Command or Action                                                                                                                                                                                                                                                                                                                                                                                                           | Purpose                                                                                                                                                                                                                                                                                                                                                                                                                                                                                                                                |
|----------------|-----------------------------------------------------------------------------------------------------------------------------------------------------------------------------------------------------------------------------------------------------------------------------------------------------------------------------------------------------------------------------------------------------------------------------|----------------------------------------------------------------------------------------------------------------------------------------------------------------------------------------------------------------------------------------------------------------------------------------------------------------------------------------------------------------------------------------------------------------------------------------------------------------------------------------------------------------------------------------|
| <b>Step 6</b>  | <p>Do one of the following:</p> <ul style="list-style-type: none"> <li><i>sequence-number deny source source-wildcard</i></li> <li><i>sequence-number deny protocol source source-wildcard destination destination-wildcard</i></li> </ul> <p>[precedence precedence][tos tos] [log] [time-range time-range-name] [fragments]</p> <p><b>Example:</b></p> <pre>Device(config-std-nacl)# 105 deny 10.6.6.7 0.0.0.0 255</pre>  | <p>(Optional) Specifies a deny statement in named IP access list mode.</p> <ul style="list-style-type: none"> <li>This access list uses a <b>permit</b> statement first, but a <b>deny</b> statement could appear first, depending on the order of statements you need.</li> <li>As the prompt indicates, this access list was a standard access list. If you had specified <b>extended</b> in Step 4, the prompt for this step would be Device(config-ext-nacl) and you would use the extended <b>deny</b> command syntax.</li> </ul> |
| <b>Step 7</b>  | <p>Do one of the following:</p> <ul style="list-style-type: none"> <li><i>sequence-number permit source source-wildcard</i></li> <li><i>sequence-number permit protocol source source-wildcard destination destination-wildcard</i></li> </ul> <p>[precedence precedence][tos tos] [log] [time-range time-range-name] [fragments]</p> <p><b>Example:</b></p> <pre>Device(config-ext-nacl)# 150 permit tcp any any log</pre> | <p>Specifies a permit statement in named IP access list mode.</p> <ul style="list-style-type: none"> <li>This access list happens to use a <b>permit</b> statement first, but a <b>deny</b> statement could appear first, depending on the order of statements you need.</li> <li>See the permit (IP) command for additional command syntax to permit upper layer protocols (ICMP, IGMP, TCP, and UDP).</li> <li>Use the <b>no sequence-number</b> command to delete an entry.</li> </ul>                                              |
| <b>Step 8</b>  | <p>Do one of the following:</p> <ul style="list-style-type: none"> <li><i>sequence-number deny source source-wildcard</i></li> <li><i>sequence-number deny protocol source source-wildcard destination destination-wildcard</i></li> </ul> <p>[precedence precedence][tos tos] [log] [time-range time-range-name] [fragments]</p> <p><b>Example:</b></p> <pre>Device(config-ext-nacl)# 150 deny tcp any any log</pre>       | <p>(Optional) Specifies a deny statement in named IP access list mode.</p> <ul style="list-style-type: none"> <li>This access list happens to use a <b>permit</b> statement first, but a <b>deny</b> statement could appear first, depending on the order of statements you need.</li> <li>See the deny (IP) command for additional command syntax to permit upper layer protocols (ICMP, IGMP, TCP, and UDP).</li> <li>Use the <b>no sequence-number</b> command to delete an entry.</li> </ul>                                       |
| <b>Step 9</b>  | Repeat Step 5 and/or Step 6 to add sequence number statements, as applicable.                                                                                                                                                                                                                                                                                                                                               | Allows you to revise the access list.                                                                                                                                                                                                                                                                                                                                                                                                                                                                                                  |
| <b>Step 10</b> | <p><b>end</b></p> <p><b>Example:</b></p> <pre>Device(config-std-nacl)# end</pre>                                                                                                                                                                                                                                                                                                                                            | (Optional) Exits the configuration mode and returns to privileged EXEC mode.                                                                                                                                                                                                                                                                                                                                                                                                                                                           |
| <b>Step 11</b> | <p><b>show ip access-lists</b> <i>access-list-name</i></p> <p><b>Example:</b></p> <pre>Device# show ip access-lists kmd1</pre>                                                                                                                                                                                                                                                                                              | (Optional) Displays the contents of the IP access list.                                                                                                                                                                                                                                                                                                                                                                                                                                                                                |

## Examples

Review the output of the **show ip access-lists** command to see that the access list includes the new entries:

```
Device# show ip access-lists kmd1

Standard IP access list kmd1
100 permit 10.4.4.0, wildcard bits 0.0.0.255
105 permit 10.5.5.0, wildcard bits 0.0.0.255
115 permit 10.0.0.0, wildcard bits 0.0.0.255
130 permit 10.5.5.0, wildcard bits 0.0.0.255
145 permit 10.0.0.0, wildcard bits 0.0.0.255
```

# Configuration Examples for IP Access List Entry Sequence Numbering

## Example: Resequencing Entries in an Access List

The following example shows access list resequencing. The starting value is 1, and increment value is 2. The subsequent entries are ordered based on the increment values specified, and the range is from 1 to 2147483647.

When an entry with no sequence number is entered, by default the entry has a sequence number of 10 more than the last entry in the access list.

```
Device# show access-list 150

Extended IP access list 150
 10 permit ip host 10.3.3.3 host 172.16.5.34
 20 permit icmp any any
 30 permit tcp any host 10.3.3.3
 40 permit ip host 10.4.4.4 any
 50 Dynamic test permit ip any any
 60 permit ip host 172.16.2.2 host 10.3.3.12
 70 permit ip host 10.3.3.3 any log
 80 permit tcp host 10.3.3.3 host 10.1.2.2
 90 permit ip host 10.3.3.3 any
100 permit ip any any

Device(config)# ip access-list extended 150
Device(config)# ip access-list resequence 150 1 2
Device(config)# exit

Device# show access-list 150

Extended IP access list 150
 1 permit ip host 10.3.3.3 host 172.16.5.34
 3 permit icmp any any
10 permit tcp any any eq 22 log
 5 permit tcp any host 10.3.3.3
 7 permit ip host 10.4.4.4 any
 9 Dynamic test permit ip any any
11 permit ip host 172.16.2.2 host 10.3.3.12
```

```
13 permit ip host 10.3.3.3 any log
15 permit tcp host 10.3.3.3 host 10.1.2.2
17 permit ip host 10.3.3.3 any
19 permit ip any any
```

## Example: Adding Entries with Sequence Numbers

In the following example, a new entry is added to a specified access list:

```
Device# show ip access-list

Standard IP access list tryon
2 permit 10.4.4.2, wildcard bits 0.0.255.255
5 permit 10.0.0.44, wildcard bits 0.0.0.255
10 permit 10.0.0.1, wildcard bits 0.0.0.255
20 permit 10.0.0.2, wildcard bits 0.0.0.255

Device(config)# ip access-list standard tryon
Device(config-std-nacl)# 15 permit 10.5.5.5 0.0.0.255
Device(config-std-nacl)# exit
Device(config)# exit
Device# show ip access-list

Standard IP access list tryon
2 permit 10.4.0.0, wildcard bits 0.0.255.255
5 permit 10.0.0.0, wildcard bits 0.0.0.255
10 permit 10.0.0.0, wildcard bits 0.0.0.255
15 permit 10.5.5.0, wildcard bits 0.0.0.255
20 permit 10.0.0.0, wildcard bits 0.0.0.255
```

## Example: Entry Without Sequence Number

The following example shows how an entry with no specified sequence number is added to the end of an access list. When an entry is added without a sequence number, it is automatically given a sequence number that puts it at the end of the access list. Because the default increment is 10, the entry will have a sequence number 10 higher than the last entry in the existing access list.

```
Device(config)# ip access-list standard 1
Device(config-std-nacl)# permit 10.1.1.1 0.0.0.255
Device(config-std-nacl)# permit 10.2.2.2 0.0.0.255
Device(config-std-nacl)# permit 10.3.3.3 0.0.0.255
Device(config-std-nacl)## exit
Device# show access-list

Standard IP access list 1
10 permit 0.0.0.0, wildcard bits 0.0.0.255
20 permit 0.0.0.0, wildcard bits 0.0.0.255
30 permit 0.0.0.0, wildcard bits 0.0.0.255

Device(config)# ip access-list standard 1
Device(config-std-nacl)# permit 10.4.4.4 0.0.0.255
Device(config-std-nacl)# end
Device(config-std-nacl)## exit
Device# show access-list

Standard IP access list 1
10 permit 0.0.0.0, wildcard bits 0.0.0.255
20 permit 0.0.0.0, wildcard bits 0.0.0.255
```

```
30 permit 0.0.0.0, wildcard bits 0.0.0.255
40 permit 0.0.0.0, wildcard bits 0.0.0.255
```

## Additional References

### Related Documents

| Related Topic               | Document Title                                                    |
|-----------------------------|-------------------------------------------------------------------|
| IP access list commands     | <i>Cisco IOS Security Command Reference</i>                       |
| Configuring IP access lists | <i>Creating an IP Access List and Applying It to an Interface</i> |

### Technical Assistance

| Description                                                                                                                                                                                                                                                                                                                                                                           | Link                                                                                                              |
|---------------------------------------------------------------------------------------------------------------------------------------------------------------------------------------------------------------------------------------------------------------------------------------------------------------------------------------------------------------------------------------|-------------------------------------------------------------------------------------------------------------------|
| The Cisco Support and Documentation website provides online resources to download documentation, software, and tools. Use these resources to install and configure the software and to troubleshoot and resolve technical issues with Cisco products and technologies. Access to most tools on the Cisco Support and Documentation website requires a Cisco.com user ID and password. | <a href="http://www.cisco.com/cisco/web/support/index.html">http://www.cisco.com/cisco/web/support/index.html</a> |

## Feature Information for IP Access List Entry Sequence Numbering

Use Cisco Feature Navigator to find information about the platform support and software image support. Cisco Feature Navigator enables you to determine which software images support a specific software release, feature set, or platform. To access Cisco Feature Navigator, go to the <https://cfng.cisco.com/> link. An account on the Cisco.com page is not required.



**Note** The following table lists the software release in which a given feature is introduced. Unless noted otherwise, subsequent releases of that software release train also support that feature.

**Table 257: Feature Information for IP Access List Entry Sequence Numbering**

| Feature Name    | Releases                 | Feature Information                                                                |
|-----------------|--------------------------|------------------------------------------------------------------------------------|
| IP Access Lists | Cisco IOS XE Fuji 16.7.1 | This feature was integrated into the Cisco cBR Series Converged Broadband Routers. |



## CHAPTER 78

# ACL IP Options Selective Drop

---

The ACL IP Options Selective Drop feature allows Cisco routers to filter packets containing IP options or to mitigate the effects of IP options on a router or downstream routers by dropping these packets or ignoring the processing of the IP options.

Your software release may not support all the features that are documented in this module. For the latest feature information and caveats, see the release notes for your platform and software release. The Feature Information Table at the end of this document provides information about the documented features and lists the releases in which each feature is supported.

Use Cisco Feature Navigator to find information about platform support and Cisco software image support. To access Cisco Feature Navigator, go to <http://tools.cisco.com/ITDIT/CFN/>. An account on <http://www.cisco.com/> is not required.

### Contents

- [Hardware Compatibility Matrix for the Cisco cBR Series Routers, on page 1243](#)
- [Restrictions for ACL IP Options Selective Drop, on page 1245](#)
- [Information About ACL IP Options Selective Drop, on page 1245](#)
- [How to Configure ACL IP Options Selective Drop, on page 1245](#)
- [Configuration Examples for ACL IP Options Selective Drop, on page 1246](#)
- [Additional References for IP Access List Entry Sequence Numbering, on page 1247](#)
- [Feature Information for ACL IP Options Selective Drop, on page 1248](#)

## Hardware Compatibility Matrix for the Cisco cBR Series Routers



---

**Note** The hardware components that are introduced in a given Cisco IOS-XE Release are supported in all subsequent releases unless otherwise specified.

---

Table 258: Hardware Compatibility Matrix for the Cisco cBR Series Routers

| Cisco CMTS Platform                    | Processor Engine                                                                                                                                                                                  | Interface Cards                                                                                                                                                                                                                                                                                                                                                                                                                                                                                                                                                                                                                                                                                                                                                                                 |
|----------------------------------------|---------------------------------------------------------------------------------------------------------------------------------------------------------------------------------------------------|-------------------------------------------------------------------------------------------------------------------------------------------------------------------------------------------------------------------------------------------------------------------------------------------------------------------------------------------------------------------------------------------------------------------------------------------------------------------------------------------------------------------------------------------------------------------------------------------------------------------------------------------------------------------------------------------------------------------------------------------------------------------------------------------------|
| Cisco cBR-8 Converged Broadband Router | <p><b>Cisco IOS-XE Release 16.5.1 and Later Releases</b></p> <p>Cisco cBR-8 Supervisor:</p> <ul style="list-style-type: none"> <li>• PID—CBR-SUP-250G</li> <li>• PID—CBR-CCAP-SUP-160G</li> </ul> | <p><b>Cisco IOS-XE Release 16.5.1 and Later Releases</b></p> <p>Cisco cBR-8 CCAP Line Cards:</p> <ul style="list-style-type: none"> <li>• PID—CBR-LC-8D30-16U30</li> <li>• PID—CBR-LC-8D31-16U30</li> <li>• PID—CBR-RF-PIC</li> <li>• PID—CBR-RF-PROT-PIC</li> <li>• PID—CBR-CCAP-LC-40G</li> <li>• PID—CBR-CCAP-LC-40G-R</li> <li>• PID—CBR-CCAP-LC-G2-R</li> <li>• PID—CBR-SUP-8X10G-PIC</li> <li>• PID—CBR-2X100G-PIC</li> </ul> <p>Digital PICs:</p> <ul style="list-style-type: none"> <li>• PID—CBR-DPIC-8X10G</li> <li>• PID—CBR-DPIC-2X100G</li> </ul> <p>Cisco cBR-8 Downstream PHY Module:</p> <ul style="list-style-type: none"> <li>• PID—CBR-D31-DS-MOD</li> </ul> <p>Cisco cBR-8 Upstream PHY Modules:</p> <ul style="list-style-type: none"> <li>• PID—CBR-D31-US-MOD</li> </ul> |



**Note** Do not use DPICs (8X10G and 2x100G) to forward IP traffic, as it may cause buffer exhaustion, leading to line card reload.

The only allowed traffic on a DPIC interface is DEPI, UEPI, and GCP traffic from the Cisco cBR-8 router to Remote PHY devices. Other traffic such as DHCP, SSH, and UTSC should flow via another router, since DPICs cannot be used for normal routing.



# Restrictions for ACL IP Options Selective Drop

Resource Reservation Protocol (RSVP) (Multiprotocol Label Switching traffic engineering [MPLS TE]), Internet Group Management Protocol Version 2 (IGMPv2), and other protocols that use IP options packets may not function in drop or ignore modes.

## Information About ACL IP Options Selective Drop

### Using ACL IP Options Selective Drop

The ACL IP Options Selective Drop feature allows a router to filter IP options packets, thereby mitigating the effects of these packets on a router and downstream routers, and perform the following actions:

- Drop all IP options packets that it receives and prevent options from going deeper into the network.
- Ignore IP options packets destined for the router and treat them as if they had no IP options.

For many users, dropping the packets is the best solution. However, in environments in which some IP options may be legitimate, reducing the load that the packets present on the routers is sufficient. Therefore, users may prefer to skip options processing on the router and forward the packet as though it were pure IP.

### Benefits of Using ACL IP Options Selective Drop

- Drop mode filters packets from the network and relieves downstream routers and hosts of the load from options packets.
- Drop mode minimizes loads to the Route Processor (RP) for options that require RP processing on distributed systems. Previously, the packets were always routed to or processed by the RP CPU. Now, the ignore and drop forms prevent the packets from impacting the RP performance.

## How to Configure ACL IP Options Selective Drop

### Configuring ACL IP Options Selective Drop

This section describes how to configure the ACL IP Options Selective Drop feature.

#### SUMMARY STEPS

1. **enable**
2. **configure terminal**
3. **ip options {drop | ignore}**
4. **exit**
5. **show ip traffic**

## DETAILED STEPS

|        | Command or Action                                                                       | Purpose                                                             |
|--------|-----------------------------------------------------------------------------------------|---------------------------------------------------------------------|
| Step 1 | <b>enable</b><br><b>Example:</b><br>Router> enable                                      | Enables privileged EXEC mode.<br>• Enter your password if prompted. |
| Step 2 | <b>configure terminal</b><br><b>Example:</b><br>Router# configure terminal              | Enters global configuration mode.                                   |
| Step 3 | <b>ip options {drop   ignore}</b><br><b>Example:</b><br>Router(config)# ip options drop | Drops or ignores IP options packets that are sent to the router.    |
| Step 4 | <b>exit</b><br><b>Example:</b><br>Router(config)# exit                                  | Returns to privileged EXEC mode.                                    |
| Step 5 | <b>show ip traffic</b><br><b>Example:</b><br>Router# show ip traffic                    | (Optional) Displays statistics about IP traffic.                    |

## Configuration Examples for ACL IP Options Selective Drop

### Example Configuring ACL IP Options Selective Drop

The following example shows how to configure the router (and downstream routers) to drop all options packets that enter the network:

```
Router(config)# ip options drop
% Warning:RSVP and other protocols that use IP Options packets may not function in drop or
ignore modes.
end
```

### Example Verifying ACL IP Options Selective Drop

The following sample output is displayed after using the **ip options drop** command:

```
Router# show ip traffic
IP statistics:
  Rcvd: 428 total, 323 local destination
```

```

0 format errors, 0 checksum errors, 0 bad hop count
0 unknown protocol, 0 not a gateway
0 security failures, 0 bad options, 0 with options
Opts: 0 end, 0 nop, 0 basic security, 0 loose source route
0 timestamp, 0 extended security, 0 record route
0 stream ID, 0 strict source route, 0 alert, 0 cipso, 0 ump
0 other, 30 ignored
Frag: 0 reassembled, 0 timeouts, 0 couldn't reassemble
0 fragmented, 0 fragments, 0 couldn't fragment
Bcast: 0 received, 0 sent
Mcast: 323 received, 809 sent
Sent: 809 generated, 591 forwarded
Drop: 0 encapsulation failed, 0 unresolved, 0 no adjacency
0 no route, 0 unicast RPF, 0 forced drop, 0 unsupported-addr
0 options denied, 0 source IP address zero

```

## Additional References for IP Access List Entry Sequence Numbering

The following sections provide references related to IP access lists.

### Related Documents

| Related Topic               | Document Title                                                                                                                                                                                                                                                                                                                                                               |
|-----------------------------|------------------------------------------------------------------------------------------------------------------------------------------------------------------------------------------------------------------------------------------------------------------------------------------------------------------------------------------------------------------------------|
| Configuring IP access lists | "Creating an IP Access List and Applying It to an Interface"                                                                                                                                                                                                                                                                                                                 |
| IP access list commands     | <ul style="list-style-type: none"> <li>• <a href="#">Cisco IOS Security Command Reference: Commands A to C</a></li> <li>• <a href="#">Cisco IOS Security Command Reference: Commands D to L</a></li> <li>• <a href="#">Cisco IOS Security Command Reference: Commands M to R</a></li> <li>• <a href="#">Cisco IOS Security Command Reference: Commands S to Z</a></li> </ul> |

**Technical Assistance**

| Description                                                                                                                                                                                                                                                                                                                                                                                                                                                                                                                                                             | Link                                                                            |
|-------------------------------------------------------------------------------------------------------------------------------------------------------------------------------------------------------------------------------------------------------------------------------------------------------------------------------------------------------------------------------------------------------------------------------------------------------------------------------------------------------------------------------------------------------------------------|---------------------------------------------------------------------------------|
| <p>The Cisco Support website provides extensive online resources, including documentation and tools for troubleshooting and resolving technical issues with Cisco products and technologies.</p> <p>To receive security and technical information about your products, you can subscribe to various services, such as the Product Alert Tool (accessed from Field Notices), the Cisco Technical Services Newsletter, and Really Simple Syndication (RSS) Feeds.</p> <p>Access to most tools on the Cisco Support website requires a Cisco.com user ID and password.</p> | <a href="http://www.cisco.com/techsupport">http://www.cisco.com/techsupport</a> |

## Feature Information for ACL IP Options Selective Drop

Use Cisco Feature Navigator to find information about the platform support and software image support. Cisco Feature Navigator enables you to determine which software images support a specific software release, feature set, or platform. To access Cisco Feature Navigator, go to the <https://cfng.cisco.com/> link. An account on the Cisco.com page is not required.



**Note** The following table lists the software release in which a given feature is introduced. Unless noted otherwise, subsequent releases of that software release train also support that feature.

**Table 259: Feature Information for ACL IP Options Selective Drop**

| Feature Name    | Releases                 | Feature Information                                                                                            |
|-----------------|--------------------------|----------------------------------------------------------------------------------------------------------------|
| IP access lists | Cisco IOS XE Fuji 16.7.1 | This feature was integrated into Cisco IOS XE Fuji 16.7.1 on the Cisco cBR Series Converged Broadband Routers. |



## CHAPTER 79

# ACL Syslog Correlation

---

The Access Control List (ACL) Syslog Correlation feature appends a tag (either a user-defined cookie or a device-generated MD5 hash value) to access control entry (ACE) syslog entries. This tag uniquely identifies the ACE, within the ACL, that generated the syslog entry.

Your software release may not support all the features that are documented in this module. For the latest feature information and caveats, see the release notes for your platform and software release. The Feature Information Table at the end of this document provides information about the documented features and lists the releases in which each feature is supported.

Use Cisco Feature Navigator to find information about platform support and Cisco software image support. To access Cisco Feature Navigator, go to <http://tools.cisco.com/ITDIT/CFN/>. An account on <http://www.cisco.com/> is not required.

### Contents

- [Hardware Compatibility Matrix for the Cisco cBR Series Routers, on page 1249](#)
- [Prerequisites for ACL Syslog Correlation, on page 1251](#)
- [Information About ACL Syslog Correlation, on page 1251](#)
- [How to Configure ACL Syslog Correlation, on page 1252](#)
- [Configuration Examples for ACL Syslog Correlation, on page 1258](#)
- [Additional References for IPv6 IOS Firewall, on page 1260](#)
- [Feature Information for ACL Syslog Correlation, on page 1260](#)

## Hardware Compatibility Matrix for the Cisco cBR Series Routers



---

**Note** The hardware components that are introduced in a given Cisco IOS-XE Release are supported in all subsequent releases unless otherwise specified.

---

Table 260: Hardware Compatibility Matrix for the Cisco cBR Series Routers

| Cisco CMTS Platform                    | Processor Engine                                                                                                                                                                                  | Interface Cards                                                                                                                                                                                                                                                                                                                                                                                                                                                                                                                                                                                                                                                                                                                                                                                 |
|----------------------------------------|---------------------------------------------------------------------------------------------------------------------------------------------------------------------------------------------------|-------------------------------------------------------------------------------------------------------------------------------------------------------------------------------------------------------------------------------------------------------------------------------------------------------------------------------------------------------------------------------------------------------------------------------------------------------------------------------------------------------------------------------------------------------------------------------------------------------------------------------------------------------------------------------------------------------------------------------------------------------------------------------------------------|
| Cisco cBR-8 Converged Broadband Router | <p><b>Cisco IOS-XE Release 16.5.1 and Later Releases</b></p> <p>Cisco cBR-8 Supervisor:</p> <ul style="list-style-type: none"> <li>• PID—CBR-SUP-250G</li> <li>• PID—CBR-CCAP-SUP-160G</li> </ul> | <p><b>Cisco IOS-XE Release 16.5.1 and Later Releases</b></p> <p>Cisco cBR-8 CCAP Line Cards:</p> <ul style="list-style-type: none"> <li>• PID—CBR-LC-8D30-16U30</li> <li>• PID—CBR-LC-8D31-16U30</li> <li>• PID—CBR-RF-PIC</li> <li>• PID—CBR-RF-PROT-PIC</li> <li>• PID—CBR-CCAP-LC-40G</li> <li>• PID—CBR-CCAP-LC-40G-R</li> <li>• PID—CBR-CCAP-LC-G2-R</li> <li>• PID—CBR-SUP-8X10G-PIC</li> <li>• PID—CBR-2X100G-PIC</li> </ul> <p>Digital PICs:</p> <ul style="list-style-type: none"> <li>• PID—CBR-DPIC-8X10G</li> <li>• PID—CBR-DPIC-2X100G</li> </ul> <p>Cisco cBR-8 Downstream PHY Module:</p> <ul style="list-style-type: none"> <li>• PID—CBR-D31-DS-MOD</li> </ul> <p>Cisco cBR-8 Upstream PHY Modules:</p> <ul style="list-style-type: none"> <li>• PID—CBR-D31-US-MOD</li> </ul> |



**Note** Do not use DPICs (8X10G and 2x100G) to forward IP traffic, as it may cause buffer exhaustion, leading to line card reload.

The only allowed traffic on a DPIC interface is DEPI, UEPI, and GCP traffic from the Cisco cBR-8 router to Remote PHY devices. Other traffic such as DHCP, SSH, and UTSC should flow via another router, since DPICs cannot be used for normal routing.

## Prerequisites for ACL Syslog Correlation

Before you configure the ACL Syslog Correlation feature, you must understand the concepts in the "IP Access List Overview" module.

The ACL Syslog Correlation feature appends a user-defined cookie or a device-generated hash value to ACE messages in the syslog. These values are only appended to ACE messages when the log option is enabled for the ACE.

## Information About ACL Syslog Correlation

### ACL Syslog Correlation Tags

The ACL Syslog Correlation feature appends a tag (either a user-defined cookie or a device-generated MD5 hash value) to access control entry (ACE) syslog entries. This tag uniquely identifies an ACE that generated the syslog entry.

Network management software can use the tag to identify which ACE generated a specific syslog event. For example, network administrators can select an ACE rule in the network management application and can then view the corresponding syslog events for that ACE rule.

To append a tag to the syslog message, the ACE that generates the syslog event must have the log option enabled. The system appends only one type of tag (either a user-defined cookie or a device-generated MD5 hash value) to each message.

To specify a user-defined cookie tag, the user must enter the cookie value when configuring the ACE log option. The cookie must be in alpha-numeric form, it cannot be greater than 64 characters, and it cannot start with hex-decimal notation (such as 0x).

To specify a device-generated MD5 hash value tag, the hash-generation mechanism must be enabled on the device and the user must not enter a cookie value while configuring the ACE log option.

### ACE Syslog Messages

When a packet is matched against an access control entry (ACE) in an ACL, the system checks whether the log option is enabled for that event. If the log option is enabled and the ACL Syslog Correlation feature is configured on the device, the system attaches the tag to the syslog message. The tag is displayed at the end of the syslog message, in addition to the standard information.

The following is a sample syslog message showing a user-defined cookie tag:

```
Jun 5 12:55:44.359: %SEC-6-IPACCESSLOGP: list logacl permitted tcp 192.168.16.1(38402) -> 192.168.16.2(23), 1 packet [User_permitted_ACE]
```

The following is a sample syslog message showing a hash value tag:

```
Jun 5 12:55:44.359: %SEC-6-IPACCESSLOGP: list logacl permitted tcp 192.168.16.1(38402) -> 192.168.16.2(23), 1 packet [0x723E6E12]
```

# How to Configure ACL Syslog Correlation

## Enabling Hash Value Generation on a Device

Perform this task to configure the device to generate an MD5 hash value for each log-enabled access control entry (ACE) in the system that is not configured with a user-defined cookie.

When the hash value generation setting is enabled, the system checks all existing ACEs and generates a hash value for each ACE that requires one. When the hash value generation setting is disabled, all previously generated hash values are removed from the system.

### SUMMARY STEPS

1. **enable**
2. **configure terminal**
3. **ip access-list logging hash-generation**
4. **end**
5. Do one of the following:
  - **show ip access-list** *access-list-number*
  - **show ip access-list** *access-list-name*

### DETAILED STEPS

|               | Command or Action                                                                                                          | Purpose                                                                                                                                                                                                                                               |
|---------------|----------------------------------------------------------------------------------------------------------------------------|-------------------------------------------------------------------------------------------------------------------------------------------------------------------------------------------------------------------------------------------------------|
| <b>Step 1</b> | <b>enable</b><br><b>Example:</b><br>Device> enable                                                                         | Enables privileged EXEC mode. <ul style="list-style-type: none"> <li>• Enter your password if prompted.</li> </ul>                                                                                                                                    |
| <b>Step 2</b> | <b>configure terminal</b><br><b>Example:</b><br>Device# configure terminal                                                 | Enters global configuration mode.                                                                                                                                                                                                                     |
| <b>Step 3</b> | <b>ip access-list logging hash-generation</b><br><b>Example:</b><br>Device(config)# ip access-list logging hash-generation | Enables hash value generation on the device. <ul style="list-style-type: none"> <li>• If an ACE exists that is log enabled, and requires a hash value, the device automatically generates the value and displays the value on the console.</li> </ul> |
| <b>Step 4</b> | <b>end</b><br><b>Example:</b><br>Device(config)# end                                                                       | (Optional) Exits global configuration mode and returns to privileged EXEC mode.                                                                                                                                                                       |



|               | Command or Action                                                                                                                                                                                                                                                                                                    | Purpose                                                                                                                                                                                                                                  |
|---------------|----------------------------------------------------------------------------------------------------------------------------------------------------------------------------------------------------------------------------------------------------------------------------------------------------------------------|------------------------------------------------------------------------------------------------------------------------------------------------------------------------------------------------------------------------------------------|
| <b>Step 5</b> | Do one of the following: <ul style="list-style-type: none"> <li>• <b>show ip access-list</b> <i>access-list-number</i></li> <li>• <b>show ip access-list</b> <i>access-list-name</i></li> </ul> <b>Example:</b><br><br>Device# show ip access-list 101<br><br><b>Example:</b><br><br>Device# show ip access-list acl | (Optional) Displays the contents of the numbered or named IP access list. <ul style="list-style-type: none"> <li>• Review the output to confirm that the access list for a log-enabled ACE includes the generated hash value.</li> </ul> |

## Disabling Hash Value Generation on a Device

Perform this task to disable hash value generation on the device. When the hash value generation setting is disabled, all previously generated hash values are removed from the system.

### SUMMARY STEPS

1. **enable**
2. **configure terminal**
3. **no ip access-list logging hash-generation**
4. **end**
5. Do one of the following:
  - **show ip access-list** *access-list-number*
  - **show ip access-list** *access-list-name*

### DETAILED STEPS

|               | Command or Action                                                                                                                        | Purpose                                                                                                                                                                  |
|---------------|------------------------------------------------------------------------------------------------------------------------------------------|--------------------------------------------------------------------------------------------------------------------------------------------------------------------------|
| <b>Step 1</b> | <b>enable</b><br><br><b>Example:</b><br><br>Device> enable                                                                               | Enables privileged EXEC mode. <ul style="list-style-type: none"> <li>• Enter your password if prompted.</li> </ul>                                                       |
| <b>Step 2</b> | <b>configure terminal</b><br><br><b>Example:</b><br><br>Device# configure terminal                                                       | Enters global configuration mode.                                                                                                                                        |
| <b>Step 3</b> | <b>no ip access-list logging hash-generation</b><br><br><b>Example:</b><br><br>Device(config)# no ip access-list logging hash-generation | Disables hash value generation on the device. <ul style="list-style-type: none"> <li>• The system removes any previously created hash values from the system.</li> </ul> |

|               | Command or Action                                                                                                                                                                                                                                                                                                           | Purpose                                                                                                                                                                                                                   |
|---------------|-----------------------------------------------------------------------------------------------------------------------------------------------------------------------------------------------------------------------------------------------------------------------------------------------------------------------------|---------------------------------------------------------------------------------------------------------------------------------------------------------------------------------------------------------------------------|
| <b>Step 4</b> | <b>end</b><br><b>Example:</b><br><pre>Device(config)# end</pre>                                                                                                                                                                                                                                                             | (Optional) Exits global configuration mode and returns to privileged EXEC mode.                                                                                                                                           |
| <b>Step 5</b> | Do one of the following: <ul style="list-style-type: none"> <li>• <b>show ip access-list</b> <i>access-list-number</i></li> <li>• <b>show ip access-list</b> <i>access-list-name</i></li> </ul> <b>Example:</b><br><pre>Device# show ip access-list 101</pre> <b>Example:</b><br><pre>Device# show ip access-list acl</pre> | (Optional) Displays the contents of the IP access list. <ul style="list-style-type: none"> <li>• Review the output to confirm that the access list for a log-enabled ACE does not have a generated hash value.</li> </ul> |

## Configuring ACL Syslog Correlation Using a User-Defined Cookie

Perform this task to configure the ACL Syslog Correlation feature on a device for a specific access list, using a user-defined cookie as the syslog message tag.

The example in this section shows how to configure the ACL Syslog Correlation feature using a user-defined cookie for a numbered access list. However, you can configure the ACL Syslog Correlation feature using a user-defined cookie for both numbered and named access lists, and for both standard and extended access lists.



**Note** The following restrictions apply when choosing the user-defined cookie value:

- The maximum number of characters is 64.
- The cookie cannot start with hexadecimal notation (such as 0x).
- The cookie cannot be the same as, or a subset of, the following keywords: **reflect**, **fragment**, **time-range**. For example, reflect and ref are not valid values. However, the cookie can start with the keywords. For example, reflectedACE and fragment\_33 are valid values
- The cookie must contain only alphanumeric characters.

>

### SUMMARY STEPS

1. **enable**
2. **configure terminal**
3. **access-list** *access-list-number* **permit** *protocol source destination log word*
4. **end**
5. **show ip access-list** *access-list-number*

## DETAILED STEPS

|               | Command or Action                                                                                                                                                                                                        | Purpose                                                                                                                                                                                               |
|---------------|--------------------------------------------------------------------------------------------------------------------------------------------------------------------------------------------------------------------------|-------------------------------------------------------------------------------------------------------------------------------------------------------------------------------------------------------|
| <b>Step 1</b> | <b>enable</b><br><b>Example:</b><br>Device> enable                                                                                                                                                                       | Enables privileged EXEC mode. <ul style="list-style-type: none"> <li>• Enter your password if prompted.</li> </ul>                                                                                    |
| <b>Step 2</b> | <b>configure terminal</b><br><b>Example:</b><br>Device# configure terminal                                                                                                                                               | Enters global configuration mode.                                                                                                                                                                     |
| <b>Step 3</b> | <b>access-list</b> <i>access-list-number</i> <b>permit</b> <i>protocol source destination log word</i><br><b>Example:</b><br>Device(config)# access-list 101 permit tcp host 10.1.1.1 host 10.1.1.2 log UserDefinedValue | Defines an extended IP access list and a user-defined cookie value. <ul style="list-style-type: none"> <li>• Enter the cookie value as the <i>word</i> argument.</li> </ul>                           |
| <b>Step 4</b> | <b>end</b><br><b>Example:</b><br>Device(config)# end                                                                                                                                                                     | (Optional) Exits global configuration mode and returns to privileged EXEC mode.                                                                                                                       |
| <b>Step 5</b> | <b>show ip access-list</b> <i>access-list-number</i><br><b>Example:</b><br>Device# show ip access-list 101                                                                                                               | (Optional) Displays the contents of the IP access list. <ul style="list-style-type: none"> <li>• Review the output to confirm that the access list includes the user-defined cookie value.</li> </ul> |

**Examples**

The following is sample output from the **show ip access-list** command for an access list with a user-defined cookie value.

```
Device# show ip access-list
101
Extended IP access list 101
30 permit tcp host 10.1.1.1 host 10.1.1.2 log (tag = UserDefinedValue)
```

## Configuring ACL Syslog Correlation Using a Hash Value

Perform this task to configure the ACL Syslog Correlation feature on a device for a specific access list, using a device-generated hash value as the syslog message tag.

The steps in this section shows how to configure the ACL Syslog Correlation feature using a device-generated hash value for a numbered access list. However, you can configure the ACL Syslog Correlation feature using

a device-generated hash value for both numbered and named access lists, and for both standard and extended access lists.

## SUMMARY STEPS

1. **enable**
2. **configure terminal**
3. **ip access-list logging hash-generation**
4. **access-list *access-list-number* permit protocol source destination log**
5. **end**
6. **show ip access-list *access-list-number***

## DETAILED STEPS

|               | Command or Action                                                                                                                                                                    | Purpose                                                                                                                                                                                                                                                             |
|---------------|--------------------------------------------------------------------------------------------------------------------------------------------------------------------------------------|---------------------------------------------------------------------------------------------------------------------------------------------------------------------------------------------------------------------------------------------------------------------|
| <b>Step 1</b> | <b>enable</b><br><b>Example:</b><br>Device> enable                                                                                                                                   | Enables privileged EXEC mode. <ul style="list-style-type: none"> <li>• Enter your password if prompted.</li> </ul>                                                                                                                                                  |
| <b>Step 2</b> | <b>configure terminal</b><br><b>Example:</b><br>Device# configure terminal                                                                                                           | Enters global configuration mode.                                                                                                                                                                                                                                   |
| <b>Step 3</b> | <b>ip access-list logging hash-generation</b><br><b>Example:</b><br>Device(config)# ip access-list logging hash-generation                                                           | Enables hash value generation on the device. <ul style="list-style-type: none"> <li>• If an ACE exists that is log enabled, and requires a hash value, the device automatically generates the value and displays the value on the console.</li> </ul>               |
| <b>Step 4</b> | <b>access-list <i>access-list-number</i> permit protocol source destination log</b><br><b>Example:</b><br>Device(config)# access-list 102 permit tcp host 10.1.1.1 host 10.1.1.2 log | Defines an extended IP access list. <ul style="list-style-type: none"> <li>• Enable the log option for the access list, but do not specify a cookie value.</li> <li>• The device automatically generates a hash value for the newly defined access list.</li> </ul> |
| <b>Step 5</b> | <b>end</b><br><b>Example:</b><br>Device(config)# end                                                                                                                                 | (Optional) Exits global configuration mode and returns to privileged EXEC mode.                                                                                                                                                                                     |
| <b>Step 6</b> | <b>show ip access-list <i>access-list-number</i></b><br><b>Example:</b><br>Device# show ip access-list 102                                                                           | (Optional) Displays the contents of the IP access list. <ul style="list-style-type: none"> <li>• Review the output to confirm that the access list includes the router-generated hash value.</li> </ul>                                                             |

## Examples

The following is sample output from the **show ip access-list** command for an access list with a device-generated hash value.

```
Device# show ip access-list
102
Extended IP access list 102
10 permit tcp host 10.1.1.1 host 10.1.1.2 log (hash = 0x7F9CF6B9)
```

## Changing the ACL Syslog Correlation Tag Value

Perform this task to change the value of the user-defined cookie or replace a device-generated hash value with a user-defined cookie.

The steps in this section shows how to change the ACL Syslog Correlation tag value on a numbered access list. However, you can change the ACL Syslog Correlation tag value for both numbered and named access lists, and for both standard and extended access lists.

### SUMMARY STEPS

1. **enable**
2. **show access-list**
3. **configure terminal**
4. **access-list *access-list-number* permit protocol source destination log word**
5. **end**
6. **show ip access-list *access-list-number***

### DETAILED STEPS

|        | Command or Action                                                                        | Purpose                                                                 |
|--------|------------------------------------------------------------------------------------------|-------------------------------------------------------------------------|
| Step 1 | <b>enable</b><br><b>Example:</b><br>Device> enable                                       | Enables privileged EXEC mode.<br><br>• Enter your password if prompted. |
| Step 2 | <b>show access-list</b><br><b>Example:</b><br>Device(config)# show access-list           | (Optional) Displays the contents of the access list.                    |
| Step 3 | <b>configure terminal</b><br><b>Example:</b><br>Device# configure terminal               | Enters global configuration mode.                                       |
| Step 4 | <b>access-list <i>access-list-number</i> permit protocol source destination log word</b> | Modifies the cookie or changes the hash value to a cookie.              |

|               | Command or Action                                                                                                                                                                                                                                                                | Purpose                                                                                                                                                                 |
|---------------|----------------------------------------------------------------------------------------------------------------------------------------------------------------------------------------------------------------------------------------------------------------------------------|-------------------------------------------------------------------------------------------------------------------------------------------------------------------------|
|               | <p><b>Example:</b></p> <pre>Device(config)# access-list 101 permit tcp host 10.1.1.1 host 10.1.1.2 log NewUDV</pre> <p><b>Example:</b></p> <p>OR</p> <p><b>Example:</b></p> <p><b>Example:</b></p> <pre>Device(config)# access-list 101 permit tcp any any log replacehash</pre> | <ul style="list-style-type: none"> <li>You must enter the entire access list configuration command, replacing the previous tag value with the new tag value.</li> </ul> |
| <b>Step 5</b> | <p><b>end</b></p> <p><b>Example:</b></p> <pre>Device(config)# end</pre>                                                                                                                                                                                                          | (Optional) Exits global configuration mode and returns to privileged EXEC mode.                                                                                         |
| <b>Step 6</b> | <p><b>show ip access-list <i>access-list-number</i></b></p> <p><b>Example:</b></p> <pre>Device# show ip access-list 101</pre>                                                                                                                                                    | <p>(Optional) Displays the contents of the IP access list.</p> <ul style="list-style-type: none"> <li>Review the output to confirm the changes.</li> </ul>              |

## Troubleshooting Tips

Use the **debug ip access-list hash-generation** command to display access list debug information. The following is an example of the **debug** command output:

```
Device# debug ip access-list hash-generation
 Syslog hash code generation debugging is on
Device# show debug
IP ACL:
 Syslog hash code generation debugging is on
Device# no debug ip access-list hash-generation

 Syslog hash code generation debugging is off
Device# show debug
Device#
```

## Configuration Examples for ACL Syslog Correlation

### Example: Configuring ACL Syslog Correlation Using a User-Defined Cookie

The following example shows how to configure the ACL Syslog Correlation feature on a device using a user-defined cookie.

```

Device#
Device# debug ip access-list hash-generation
Syslog MD5 hash code generation debugging is on
Device# configure terminal
Enter configuration commands, one per line. End with CNTL/Z.
Device(config)# access-list 33 permit 10.10.10.6 log cook_33_std
Device(config)# do show ip access 33
Standard IP access list 33
10 permit 10.10.10.6 log (tag = cook_33_std)
Device(config)# end

```

## Example: Configuring ACL Syslog Correlation using a Hash Value

The following examples shows how to configure the ACL Syslog Correlation feature on a device using a device-generated hash value.

```

Device# debug ip access-list hash-generation
Syslog MD5 hash code generation debugging is on
Device# configure terminal
Enter configuration commands, one per line. End with CNTL/Z.
Device(config)# access-list 33 permit 10.10.10.7 log
Device(config)#
*Nov 7 13:51:23.615: %IPACL-HASHGEN: Hash Input: 33 standard permit 10.10.10.7
Hash Output: 0xCE87F535
Device(config)#
do show ip access 33

Standard IP access list 33
 10 permit 10.10.10.6 log (tag = cook_33_std)
 20 permit 10.10.10.7 log (hash = 0xCE87F535)

```

## Example: Changing the ACL Syslog Correlation Tag Value

The following example shows how to replace an existing access list user-defined cookie with a new cookie value, and how to replace a device-generated hash value with a user-defined cookie value.

```

Device# configure terminal
Enter configuration commands, one per line. End with CNTL/Z.
Device(config)# do show ip access-list 101
Extended IP access list 101
 10 permit tcp host 10.1.1.1 host 10.1.1.2 log (tag = MyCookie)
 20 permit tcp any any log (hash = 0x75F078B9)
Device(config)# access-list 101 permit tcp host 10.1.1.1 host 10.1.1.2 log NewUDV
Device(config)# do show access-list
Extended IP access list 101
 10 permit tcp host 10.1.1.1 host 10.1.1.2 log (tag = NewUDV)
 20 permit tcp any any log (hash = 0x75F078B9)
Device(config)# access-list 101 permit tcp any any log replacehash
Device(config)# do show access-list
Extended IP access list 101
 10 permit tcp host 10.1.1.1 host 10.1.1.2 log (tag = NewUDV)
 20 permit tcp any any log (tag = replacehash)

```

## Additional References for IPv6 IOS Firewall

### Related Documents

| Related Topic                    | Document Title                                                                                                                                                                                                                                                                                                                                                               |
|----------------------------------|------------------------------------------------------------------------------------------------------------------------------------------------------------------------------------------------------------------------------------------------------------------------------------------------------------------------------------------------------------------------------|
| Security commands                | <ul style="list-style-type: none"> <li>• <a href="#">Cisco IOS Security Command Reference: Commands A to C</a></li> <li>• <a href="#">Cisco IOS Security Command Reference: Commands D to L</a></li> <li>• <a href="#">Cisco IOS Security Command Reference: Commands M to R</a></li> <li>• <a href="#">Cisco IOS Security Command Reference: Commands S to Z</a></li> </ul> |
| IPv6 commands                    | <a href="#">Cisco IOS IPv6 Command Reference</a>                                                                                                                                                                                                                                                                                                                             |
| IPv6 addressing and connectivity | <a href="#">IPv6 Configuration Guide</a>                                                                                                                                                                                                                                                                                                                                     |
| Cisco IOS IPv6 features          | <a href="#">Cisco IOS IPv6 Feature Mapping</a>                                                                                                                                                                                                                                                                                                                               |

### Standards and RFCs

| Standard/RFC  | Title            |
|---------------|------------------|
| RFCs for IPv6 | <i>IPv6 RFCs</i> |

### Technical Assistance

| Description                                                                                                                                                                                                                                                                                                                                                                           | Link                                                                                                              |
|---------------------------------------------------------------------------------------------------------------------------------------------------------------------------------------------------------------------------------------------------------------------------------------------------------------------------------------------------------------------------------------|-------------------------------------------------------------------------------------------------------------------|
| The Cisco Support and Documentation website provides online resources to download documentation, software, and tools. Use these resources to install and configure the software and to troubleshoot and resolve technical issues with Cisco products and technologies. Access to most tools on the Cisco Support and Documentation website requires a Cisco.com user ID and password. | <a href="http://www.cisco.com/cisco/web/support/index.html">http://www.cisco.com/cisco/web/support/index.html</a> |

## Feature Information for ACL Syslog Correlation

Use Cisco Feature Navigator to find information about the platform support and software image support. Cisco Feature Navigator enables you to determine which software images support a specific software release,



feature set, or platform. To access Cisco Feature Navigator, go to the <https://cfmg.cisco.com/> link. An account on the Cisco.com page is not required.



**Note** The following table lists the software release in which a given feature is introduced. Unless noted otherwise, subsequent releases of that software release train also support that feature.

**Table 261: Feature Information for ACL Syslog Correlation**

| Feature Name    | Releases                 | Feature Information                                                                                            |
|-----------------|--------------------------|----------------------------------------------------------------------------------------------------------------|
| IP access lists | Cisco IOS XE Fuji 16.7.1 | This feature was integrated into Cisco IOS XE Fuji 16.7.1 on the Cisco cBR Series Converged Broadband Routers. |





## CHAPTER 80

# IPv6 Access Control Lists

Access lists determine what traffic is blocked and what traffic is forwarded at device interfaces and allow filtering of traffic based on source and destination addresses, and inbound and outbound traffic to a specific interface. Standard IPv6 ACL functionality was extended to support traffic filtering based on IPv6 option headers and optional, upper-layer protocol type information for finer granularity of control. Standard IPv6 ACL functionality was extended to support traffic filtering based on IPv6 option headers and optional, upper-layer protocol type information for finer granularity of control.

Your software release may not support all the features that are documented in this module. For the latest feature information and caveats, see the release notes for your platform and software release. The Feature Information Table at the end of this document provides information about the documented features and lists the releases in which each feature is supported.

Use Cisco Feature Navigator to find information about platform support and Cisco software image support. To access Cisco Feature Navigator, go to <http://tools.cisco.com/ITDIT/CFN/>. An account on <http://www.cisco.com/> is not required.

### Contents

- [Hardware Compatibility Matrix for the Cisco cBR Series Routers, on page 1263](#)
- [Information About IPv6 Access Control Lists, on page 1265](#)
- [How to Configure IPv6 Access Control Lists, on page 1265](#)
- [Configuration Examples for IPv6 Access Control Lists, on page 1270](#)
- [Additional References, on page 1271](#)
- [Feature Information for IPv6 Access Control Lists, on page 1271](#)

## Hardware Compatibility Matrix for the Cisco cBR Series Routers



**Note** The hardware components that are introduced in a given Cisco IOS-XE Release are supported in all subsequent releases unless otherwise specified.

Table 262: Hardware Compatibility Matrix for the Cisco cBR Series Routers

| Cisco CMTS Platform                    | Processor Engine                                                                                                                                                                                  | Interface Cards                                                                                                                                                                                                                                                                                                                                                                                                                                                                                                                                                                                                                                                                                                                                                                                 |
|----------------------------------------|---------------------------------------------------------------------------------------------------------------------------------------------------------------------------------------------------|-------------------------------------------------------------------------------------------------------------------------------------------------------------------------------------------------------------------------------------------------------------------------------------------------------------------------------------------------------------------------------------------------------------------------------------------------------------------------------------------------------------------------------------------------------------------------------------------------------------------------------------------------------------------------------------------------------------------------------------------------------------------------------------------------|
| Cisco cBR-8 Converged Broadband Router | <p><b>Cisco IOS-XE Release 16.5.1 and Later Releases</b></p> <p>Cisco cBR-8 Supervisor:</p> <ul style="list-style-type: none"> <li>• PID—CBR-SUP-250G</li> <li>• PID—CBR-CCAP-SUP-160G</li> </ul> | <p><b>Cisco IOS-XE Release 16.5.1 and Later Releases</b></p> <p>Cisco cBR-8 CCAP Line Cards:</p> <ul style="list-style-type: none"> <li>• PID—CBR-LC-8D30-16U30</li> <li>• PID—CBR-LC-8D31-16U30</li> <li>• PID—CBR-RF-PIC</li> <li>• PID—CBR-RF-PROT-PIC</li> <li>• PID—CBR-CCAP-LC-40G</li> <li>• PID—CBR-CCAP-LC-40G-R</li> <li>• PID—CBR-CCAP-LC-G2-R</li> <li>• PID—CBR-SUP-8X10G-PIC</li> <li>• PID—CBR-2X100G-PIC</li> </ul> <p>Digital PICs:</p> <ul style="list-style-type: none"> <li>• PID—CBR-DPIC-8X10G</li> <li>• PID—CBR-DPIC-2X100G</li> </ul> <p>Cisco cBR-8 Downstream PHY Module:</p> <ul style="list-style-type: none"> <li>• PID—CBR-D31-DS-MOD</li> </ul> <p>Cisco cBR-8 Upstream PHY Modules:</p> <ul style="list-style-type: none"> <li>• PID—CBR-D31-US-MOD</li> </ul> |



**Note** Do not use DPICs (8X10G and 2x100G) to forward IP traffic, as it may cause buffer exhaustion, leading to line card reload.

The only allowed traffic on a DPIC interface is DEPI, UEPI, and GCP traffic from the Cisco cBR-8 router to Remote PHY devices. Other traffic such as DHCP, SSH, and UTSC should flow via another router, since DPICs cannot be used for normal routing.

# Information About IPv6 Access Control Lists

## Access Control Lists for IPv6 Traffic Filtering

The standard ACL functionality in IPv6 is similar to standard ACLs in IPv4. Access lists determine what traffic is blocked and what traffic is forwarded at device interfaces and allow filtering based on source and destination addresses, inbound and outbound to a specific interface. Each access list has an implicit deny statement at the end. IPv6 ACLs are defined and their deny and permit conditions are set using the **ipv6 access-list** command with the **deny** and **permit** keywords in global configuration mode.

IPv6 extended ACLs augments standard IPv6 ACL functionality to support traffic filtering based on IPv6 option headers and optional, upper-layer protocol type information for finer granularity of control (functionality similar to extended ACLs in IPv4).

## IPv6 Packet Inspection

The following header fields are used for IPv6 inspection: traffic class, flow label, payload length, next header, hop limit, and source or destination IP address. For further information on and descriptions of the IPv6 header fields, see RFC 2474.

## Access Class Filtering in IPv6

Filtering incoming and outgoing connections to and from the device based on an IPv6 ACL is performed using the **ipv6 access-class** command in line configuration mode. The **ipv6 access-class** command is similar to the **access-class** command, except the IPv6 ACLs are defined by a name. If the IPv6 ACL is applied to inbound traffic, the source address in the ACL is matched against the incoming connection source address and the destination address in the ACL is matched against the local device address on the interface. If the IPv6 ACL is applied to outbound traffic, the source address in the ACL is matched against the local device address on the interface and the destination address in the ACL is matched against the outgoing connection source address. We recommend that identical restrictions are set on all the virtual terminal lines because a user can attempt to connect to any of them.

# How to Configure IPv6 Access Control Lists

## Configuring IPv6 Traffic Filtering

### Creating and Configuring an IPv6 ACL for Traffic Filtering



**Note** IPv6 ACLs on the Cisco cBR router do not contain implicit permit rules. The IPv6 neighbor discovery process uses the IPv6 network-layer service; therefore, to enable IPv6 neighbor discovery, you must add IPv6 ACLs to allow IPv6 neighbor discovery packets to be sent and received on an interface. In IPv4, the Address Resolution Protocol (ARP), which is equivalent to the IPv6 neighbor discovery process, uses a separate data-link-layer protocol; therefore, by default IPv4 ACLs implicitly allow ARP packets to be sent and received on an interface.

## SUMMARY STEPS

1. **enable**
2. **configure terminal**
3. **ipv6 access-list** *access-list-name*
4. Do one of the following:
  - **permit protocol** {*source-ipv6-prefix/prefix-length* | **any** | **host** *source-ipv6-address*} [*operator* [*port-number*]] {*destination-ipv6-prefix / prefix-length* | **any** | **host** *destination-ipv6-address*} [**operator** [*port-number*]] [**dest-option-type** [*doh-number* | *doh-type*]] [**dscp** *value*] [**flow-label** *value*] [**fragments**] [**log**] [**log-input**] [**mobility**] [**mobility-type** [*mh-number* | *mh-type*]] [**routing**] [**routing-type** *routing-number*] [**sequence** *value*] [**time-range** *name*]
  - **deny protocol** {*source-ipv6-prefix/prefix-length* | **any** | **host** *source-ipv6-address*} [*operator* [*port-number*]] {*destination-ipv6-prefix/prefix-length* | **any** | **host** *destination-ipv6-address*} [*operator* [*port-number*]] [**dest-option-type** [*doh-number* | *doh-type*]] [**dscp** *value*] [**flow-label** *value*] [**fragments**] [**log**] [**log-input**] [**mobility**] [**mobility-type** [*mh-number* | *mh-type*]] [**routing**] [**routing-type** *routing-number*] [**sequence** *value*] [**time-range** *name*] [**undetermined-transport**]

## DETAILED STEPS

|               | Command or Action                                                                                                                                                                                                                                                                                                                                                                                                                                                                                                                                                                                                                                                                                                                                                                                                                                                                                                                      | Purpose                                                                                                                                                                                                                                                                             |
|---------------|----------------------------------------------------------------------------------------------------------------------------------------------------------------------------------------------------------------------------------------------------------------------------------------------------------------------------------------------------------------------------------------------------------------------------------------------------------------------------------------------------------------------------------------------------------------------------------------------------------------------------------------------------------------------------------------------------------------------------------------------------------------------------------------------------------------------------------------------------------------------------------------------------------------------------------------|-------------------------------------------------------------------------------------------------------------------------------------------------------------------------------------------------------------------------------------------------------------------------------------|
| <b>Step 1</b> | <b>enable</b><br><b>Example:</b><br>Device> enable                                                                                                                                                                                                                                                                                                                                                                                                                                                                                                                                                                                                                                                                                                                                                                                                                                                                                     | Enables privileged EXEC mode. <ul style="list-style-type: none"> <li>• Enter your password if prompted.</li> </ul>                                                                                                                                                                  |
| <b>Step 2</b> | <b>configure terminal</b><br><b>Example:</b><br>Device# configure terminal                                                                                                                                                                                                                                                                                                                                                                                                                                                                                                                                                                                                                                                                                                                                                                                                                                                             | Enters global configuration mode.                                                                                                                                                                                                                                                   |
| <b>Step 3</b> | <b>ipv6 access-list</b> <i>access-list-name</i><br><b>Example:</b><br>Device(config)# ipv6 access-list inbound                                                                                                                                                                                                                                                                                                                                                                                                                                                                                                                                                                                                                                                                                                                                                                                                                         | Defines an IPv6 ACL, and enters IPv6 access list configuration mode. <ul style="list-style-type: none"> <li>• The <i>access-list name</i> argument specifies the name of the IPv6 ACL. IPv6 ACL names cannot contain a space or quotation mark, or begin with a numeral.</li> </ul> |
| <b>Step 4</b> | Do one of the following: <ul style="list-style-type: none"> <li>• <b>permit protocol</b> {<i>source-ipv6-prefix/prefix-length</i>   <b>any</b>   <b>host</b> <i>source-ipv6-address</i>} [<i>operator</i> [<i>port-number</i>]] {<i>destination-ipv6-prefix / prefix-length</i>   <b>any</b>   <b>host</b> <i>destination-ipv6-address</i>} [<b>operator</b> [<i>port-number</i>]] [<b>dest-option-type</b> [<i>doh-number</i>   <i>doh-type</i>]] [<b>dscp</b> <i>value</i>] [<b>flow-label</b> <i>value</i>] [<b>fragments</b>] [<b>log</b>] [<b>log-input</b>] [<b>mobility</b>] [<b>mobility-type</b> [<i>mh-number</i>   <i>mh-type</i>]] [<b>routing</b>] [<b>routing-type</b> <i>routing-number</i>] [<b>sequence</b> <i>value</i>] [<b>time-range</b> <i>name</i>]</li> <li>• <b>deny protocol</b> {<i>source-ipv6-prefix/prefix-length</i>   <b>any</b>   <b>host</b> <i>source-ipv6-address</i>} [<i>operator</i></li> </ul> | Specifies permit or deny conditions for an IPv6 ACL.                                                                                                                                                                                                                                |

|  | Command or Action                                                                                                                                                                                                                                                                                                                                                                                                                                                                                                                                                                                                                                                                                                                                                                                                   | Purpose |
|--|---------------------------------------------------------------------------------------------------------------------------------------------------------------------------------------------------------------------------------------------------------------------------------------------------------------------------------------------------------------------------------------------------------------------------------------------------------------------------------------------------------------------------------------------------------------------------------------------------------------------------------------------------------------------------------------------------------------------------------------------------------------------------------------------------------------------|---------|
|  | <p><i>port-number</i>] {<i>destination-ipv6-prefix/prefix-length</i>   <b>any</b>   <b>host</b> <i>destination-ipv6-address</i>} [<i>operator</i> [<i>port-number</i>]] [<b>dest-option-type</b> [<i>doh-number</i>   <i>doh-type</i>]] [<b>dscp</b> <i>value</i>] [<b>flow-label</b> <i>value</i>] [<b>fragments</b>] [<b>log</b>] [<b>log-input</b>] [<b>mobility</b>] [<b>mobility-type</b> [<i>mh-number</i>   <i>mh-type</i>]] [<b>routing</b>] [<b>routing-type</b> <i>routing-number</i>] [<b>sequence</b> <i>value</i>] [<b>time-range</b> <i>name</i>] [<b>undetermined-transport</b></p> <p><b>Example:</b></p> <pre>Device(config-ipv6-acl)# permit tcp 2001:DB8:0300:0201::/32 eq telnet any</pre> <p><b>Example:</b></p> <pre>Device(config-ipv6-acl)# deny tcp host 2001:DB8:1::1 any log-input</pre> |         |

## Applying the IPv6 ACL to an Interface

### SUMMARY STEPS

1. **enable**
2. **configure terminal**
3. **interface** *type number*
4. **ipv6 traffic-filter** *access-list-name* {**in**| **out**}

### DETAILED STEPS

|               | Command or Action                                                                                                              | Purpose                                                                                                                   |
|---------------|--------------------------------------------------------------------------------------------------------------------------------|---------------------------------------------------------------------------------------------------------------------------|
| <b>Step 1</b> | <p><b>enable</b></p> <p><b>Example:</b></p> <pre>Device&gt; enable</pre>                                                       | <p>Enables privileged EXEC mode.</p> <ul style="list-style-type: none"> <li>• Enter your password if prompted.</li> </ul> |
| <b>Step 2</b> | <p><b>configure terminal</b></p> <p><b>Example:</b></p> <pre>Device# configure terminal</pre>                                  | <p>Enters global configuration mode.</p>                                                                                  |
| <b>Step 3</b> | <p><b>interface</b> <i>type number</i></p> <p><b>Example:</b></p> <pre>Device(config)# interface TenGigabitEthernet4/1/0</pre> | <p>Specifies the interface type and number, and enters interface configuration mode.</p>                                  |
| <b>Step 4</b> | <p><b>ipv6 traffic-filter</b> <i>access-list-name</i> {<b>in</b>  <b>out</b>}</p> <p><b>Example:</b></p>                       | <p>Applies the specified IPv6 access list to the interface specified in the previous step.</p>                            |

|  | Command or Action                                   | Purpose |
|--|-----------------------------------------------------|---------|
|  | Device(config-if)# ipv6 traffic-filter outbound out |         |

## Controlling Access to a vty

### Creating an IPv6 ACL to Provide Access Class Filtering

#### SUMMARY STEPS

1. **enable**
2. **configure terminal**
3. **ipv6 access-list** *access-list-name*
4. Do one of the following:
  - **permit protocol** {*source-ipv6-prefix/prefix-length* | **any** | **host** *source-ipv6-address*} [*operator* [*port-number*]] {*destination-ipv6-prefix / prefix-length* | **any** | **host** *destination-ipv6-address*} [*operator* [*port-number*]] [**dest-option-type** [*doh-number* | *doh-type*]] [**dscp** *value*] [**flow-label** *value*] [**fragments**] [**log**] [**log-input**] [**mobility**] [**mobility-type** [*mh-number* | *mh-type*]] [**routing**] [**routing-type** *routing-number*] [**sequence** *value*] [**time-range** *name*]
  - **deny protocol** {*source-ipv6-prefix/prefix-length* | **any** | **host** *source-ipv6-address*} [*operator* [*port-number*]] {*destination-ipv6-prefix/prefix-length* | **any** | **host** *destination-ipv6-address*} [*operator* [*port-number*]] [**dest-option-type** [*doh-number* | *doh-type*]] [**dscp** *value*] [**flow-label** *value*] [**fragments**] [**log**] [**log-input**] [**mobility**] [**mobility-type** [*mh-number* | *mh-type*]] [**routing**] [**routing-type** *routing-number*] [**sequence** *value*] [**time-range** *name*] [**undetermined-transport**]

#### DETAILED STEPS

|               | Command or Action                                                                                            | Purpose                                                                                                            |
|---------------|--------------------------------------------------------------------------------------------------------------|--------------------------------------------------------------------------------------------------------------------|
| <b>Step 1</b> | <b>enable</b><br><b>Example:</b><br>Device> enable                                                           | Enables privileged EXEC mode. <ul style="list-style-type: none"> <li>• Enter your password if prompted.</li> </ul> |
| <b>Step 2</b> | <b>configure terminal</b><br><b>Example:</b><br>Device# configure terminal                                   | Enters global configuration mode.                                                                                  |
| <b>Step 3</b> | <b>ipv6 access-list</b> <i>access-list-name</i><br><b>Example:</b><br>Device(config)# ipv6 access-list cisco | Defines an IPv6 ACL, and enters IPv6 access list configuration mode.                                               |



|        | Command or Action                                                                                                                                                                                                                                                                                                                                                                                                                                                                                                                                                                                                                                                                                                                                                                                                                                                                                                                                                                                                                                                                                                                                                                                                                                                                                                                                                                                                                                                                                                                                                                                                                                                                                                                          | Purpose                                              |
|--------|--------------------------------------------------------------------------------------------------------------------------------------------------------------------------------------------------------------------------------------------------------------------------------------------------------------------------------------------------------------------------------------------------------------------------------------------------------------------------------------------------------------------------------------------------------------------------------------------------------------------------------------------------------------------------------------------------------------------------------------------------------------------------------------------------------------------------------------------------------------------------------------------------------------------------------------------------------------------------------------------------------------------------------------------------------------------------------------------------------------------------------------------------------------------------------------------------------------------------------------------------------------------------------------------------------------------------------------------------------------------------------------------------------------------------------------------------------------------------------------------------------------------------------------------------------------------------------------------------------------------------------------------------------------------------------------------------------------------------------------------|------------------------------------------------------|
| Step 4 | <p>Do one of the following:</p> <ul style="list-style-type: none"> <li>• <b>permit protocol</b> {<i>source-ipv6-prefix/prefix-length</i>   <b>any</b>   <b>host</b> <i>source-ipv6-address</i>} [<i>operator</i> [<i>port-number</i>]] {<i>destination-ipv6-prefix / prefix-length</i>   <b>any</b>   <b>host</b> <i>destination-ipv6-address</i>} [<i>operator</i> [<i>port-number</i>]] [<b>dest-option-type</b> [<i>doh-number</i>   <i>doh-type</i>]] [<b>dscp</b> <i>value</i>] [<b>flow-label</b> <i>value</i>] [<b>fragments</b>] [<b>log</b>] [<b>log-input</b>] [<b>mobility</b>] [<b>mobility-type</b> [<i>mh-number</i>   <i>mh-type</i>]] [<b>routing</b>] [<b>routing-type</b> <i>routing-number</i>] [<b>sequence</b> <i>value</i>] [<b>time-range</b> <i>name</i>]</li> <li>• <b>deny protocol</b> {<i>source-ipv6-prefix/prefix-length</i>   <b>any</b>   <b>host</b> <i>source-ipv6-address</i>} [<i>operator</i> <i>port-number</i>]] {<i>destination-ipv6-prefix/prefix-length</i>   <b>any</b>   <b>host</b> <i>destination-ipv6-address</i>} [<i>operator</i> [<i>port-number</i>]] [<b>dest-option-type</b> [<i>doh-number</i>   <i>doh-type</i>]] [<b>dscp</b> <i>value</i>] [<b>flow-label</b> <i>value</i>] [<b>fragments</b>] [<b>log</b>] [<b>log-input</b>] [<b>mobility</b>] [<b>mobility-type</b> [<i>mh-number</i>   <i>mh-type</i>]] [<b>routing</b>] [<b>routing-type</b> <i>routing-number</i>] [<b>sequence</b> <i>value</i>] [<b>time-range</b> <i>name</i>] [<b>undetermined-transport</b>]</li> </ul> <p><b>Example:</b></p> <pre>Device(config-ipv6-acl)# permit ipv6 host 2001:DB8:0:4::32 any</pre> <p><b>Example:</b></p> <pre>Device(config-ipv6-acl)# deny ipv6 host 2001:DB8:0:6::6 any</pre> | Specifies permit or deny conditions for an IPv6 ACL. |

## Applying an IPv6 ACL to the Virtual Terminal Line

### SUMMARY STEPS

1. **enable**
2. **configure terminal**
3. **line** [**aux**| **console**| **tty**| **vty**] *line-number*[*ending-line-number*]
4. **ipv6 access-class** *ipv6-access-list-name* {**in**| **out**}

### DETAILED STEPS

|        | Command or Action                                                        | Purpose                                                                                                                   |
|--------|--------------------------------------------------------------------------|---------------------------------------------------------------------------------------------------------------------------|
| Step 1 | <p><b>enable</b></p> <p><b>Example:</b></p> <pre>Device&gt; enable</pre> | <p>Enables privileged EXEC mode.</p> <ul style="list-style-type: none"> <li>• Enter your password if prompted.</li> </ul> |

|               | Command or Action                                                                                                                         | Purpose                                                                                                                                                                                                                                                    |
|---------------|-------------------------------------------------------------------------------------------------------------------------------------------|------------------------------------------------------------------------------------------------------------------------------------------------------------------------------------------------------------------------------------------------------------|
| <b>Step 2</b> | <b>configure terminal</b><br><b>Example:</b><br><br>Device# configure terminal                                                            | Enters global configuration mode.                                                                                                                                                                                                                          |
| <b>Step 3</b> | <b>line [aux  console  tty  vty]</b><br><i>line-number[ending-line-number]</i><br><b>Example:</b><br><br>Device(config)# line vty 0 4     | Identifies a specific line for configuration and enters line configuration mode.<br><br><ul style="list-style-type: none"> <li>In this example, the <b>vty</b> keyword is used to specify the virtual terminal lines for remote console access.</li> </ul> |
| <b>Step 4</b> | <b>ipv6 access-class <i>ipv6-access-list-name</i> {in  out}</b><br><b>Example:</b><br><br>Device(config-line)# ipv6 access-class cisco in | Filters incoming and outgoing connections to and from the device based on an IPv6 ACL.                                                                                                                                                                     |

## Configuration Examples for IPv6 Access Control Lists

### Example: Verifying IPv6 ACL Configuration

In this example, the **show ipv6 access-list** command is used to verify that IPv6 ACLs are configured correctly:

```
Device> show ipv6 access-list

IPv6 access list inbound
  permit tcp any any eq bgp (8 matches) sequence 10
  permit tcp any any eq telnet (15 matches) sequence 20
  permit udp any any sequence 30

IPv6 access list Virtual-Access2.1#427819008151 (per-user)
  permit tcp host 2001:DB8:1::32 eq bgp host 2001:DB8:2::32 eq 11000 sequence 1
  permit tcp host 2001:DB8:1::32 eq telnet host 2001:DB8:2::32 eq 11001 sequence 2
```

### Example: Creating and Applying an IPv6 ACL

The following example shows how to restrict HTTP access to certain hours during the day and log any activity outside of the permitted hours:

```
Device# configure terminal
Device(config)# time-range lunchtime
Device(config-time-range)# periodic weekdays 12:00 to 13:00
Device(config-time-range)# exit
Device(config)# ipv6 access-list INBOUND
Device(config-ipv6-acl)# permit tcp any any eq www time-range lunchtime
Device(config-ipv6-acl)# deny tcp any any eq www log-input
Device(config-ipv6-acl)# permit tcp 2001:DB8::/32 any
```

```
Device(config-ipv6-acl)# permit udp 2001:DB8::/32 any
Device(config-ipv6-acl)# end
```

## Example: Controlling Access to a vty

In the following example, incoming connections to the virtual terminal lines 0 to 4 are filtered based on the IPv6 access list named acl1:

```
ipv6 access-list acl1
 permit ipv6 host 2001:DB8:0:4::2/32 any
!
line vty 0 4
 ipv6 access-class acl1 in
```

## Additional References

### Related Documents

| Related Topic               | Document Title                                                    |
|-----------------------------|-------------------------------------------------------------------|
| IP access list commands     | <i>Cisco IOS Security Command Reference</i>                       |
| Configuring IP access lists | <i>Creating an IP Access List and Applying It to an Interface</i> |

### Technical Assistance

| Description                                                                                                                                                                                                                                                                                                                                                                           | Link                                                                                                              |
|---------------------------------------------------------------------------------------------------------------------------------------------------------------------------------------------------------------------------------------------------------------------------------------------------------------------------------------------------------------------------------------|-------------------------------------------------------------------------------------------------------------------|
| The Cisco Support and Documentation website provides online resources to download documentation, software, and tools. Use these resources to install and configure the software and to troubleshoot and resolve technical issues with Cisco products and technologies. Access to most tools on the Cisco Support and Documentation website requires a Cisco.com user ID and password. | <a href="http://www.cisco.com/cisco/web/support/index.html">http://www.cisco.com/cisco/web/support/index.html</a> |

## Feature Information for IPv6 Access Control Lists

Use Cisco Feature Navigator to find information about the platform support and software image support. Cisco Feature Navigator enables you to determine which software images support a specific software release, feature set, or platform. To access Cisco Feature Navigator, go to the <https://cfng.cisco.com/> link. An account on the Cisco.com page is not required.



**Note** The following table lists the software release in which a given feature is introduced. Unless noted otherwise, subsequent releases of that software release train also support that feature.

*Table 263: Feature Information for IPv6 Access Control Lists*

| <b>Feature Name</b> | <b>Releases</b>          | <b>Feature Information</b>                                                                                     |
|---------------------|--------------------------|----------------------------------------------------------------------------------------------------------------|
| IPv6 Access Lists   | Cisco IOS XE Fuji 16.7.1 | This feature was integrated into Cisco IOS XE Fuji 16.7.1 on the Cisco cBR Series Converged Broadband Routers. |



# CHAPTER 81

## IPv6 Template ACL

When user profiles are configured using vendor-specific attribute (VSA) Cisco AV-pairs, similar per-user IPv6 ACLs may be replaced by a single template ACL. That is, one ACL represents many similar ACLs. By using IPv6 template ACLs, you can increase the total number of per-user ACLs while minimizing the memory and Ternary Content Addressable Memory (TCAM) resources needed to support the ACLs.

The IPv6 Template ACL feature can create templates using the following ACL fields:

- IPv6 source and destination addresses
- TCP and UDP, including all associated ports (0 through 65535)
- ICMP neighbor discovery advertisements and solicitations
- IPv6 DSCP with specified DSCP values

ACL names are dynamically generated by this feature; for example:

- 6Temp\_#152875854573--Example of a dynamically generated template name for a template ACL parent
- Virtual-Access2.32135#152875854573--Example of a child ACL or an ACL that has not yet been made part of a template.

Your software release may not support all the features that are documented in this module. For the latest feature information and caveats, see the release notes for your platform and software release. The Feature Information Table at the end of this document provides information about the documented features and lists the releases in which each feature is supported.

Use Cisco Feature Navigator to find information about platform support and Cisco software image support. To access Cisco Feature Navigator, go to <http://tools.cisco.com/ITDIT/CFN/>. An account on <http://www.cisco.com/> is not required.

### Contents

- [Hardware Compatibility Matrix for the Cisco cBR Series Routers, on page 1274](#)
- [Information About IPv6 ACL—Template ACL, on page 1275](#)
- [How to Enable IPv6 ACL—Template ACL, on page 1275](#)
- [Configuration Examples for IPv6 ACL—Template ACL, on page 1276](#)
- [Additional References, on page 1277](#)
- [Feature Information for IPv6 Template ACL, on page 1278](#)

# Hardware Compatibility Matrix for the Cisco cBR Series Routers



**Note** The hardware components that are introduced in a given Cisco IOS-XE Release are supported in all subsequent releases unless otherwise specified.

**Table 264: Hardware Compatibility Matrix for the Cisco cBR Series Routers**

| Cisco CMTS Platform                    | Processor Engine                                                                                                                                                                                  | Interface Cards                                                                                                                                                                                                                                                                                                                                                                                                                                                                                                                                                                                                                                                                                                                                                                                 |
|----------------------------------------|---------------------------------------------------------------------------------------------------------------------------------------------------------------------------------------------------|-------------------------------------------------------------------------------------------------------------------------------------------------------------------------------------------------------------------------------------------------------------------------------------------------------------------------------------------------------------------------------------------------------------------------------------------------------------------------------------------------------------------------------------------------------------------------------------------------------------------------------------------------------------------------------------------------------------------------------------------------------------------------------------------------|
| Cisco cBR-8 Converged Broadband Router | <p><b>Cisco IOS-XE Release 16.5.1 and Later Releases</b></p> <p>Cisco cBR-8 Supervisor:</p> <ul style="list-style-type: none"> <li>• PID—CBR-SUP-250G</li> <li>• PID—CBR-CCAP-SUP-160G</li> </ul> | <p><b>Cisco IOS-XE Release 16.5.1 and Later Releases</b></p> <p>Cisco cBR-8 CCAP Line Cards:</p> <ul style="list-style-type: none"> <li>• PID—CBR-LC-8D30-16U30</li> <li>• PID—CBR-LC-8D31-16U30</li> <li>• PID—CBR-RF-PIC</li> <li>• PID—CBR-RF-PROT-PIC</li> <li>• PID—CBR-CCAP-LC-40G</li> <li>• PID—CBR-CCAP-LC-40G-R</li> <li>• PID—CBR-CCAP-LC-G2-R</li> <li>• PID—CBR-SUP-8X10G-PIC</li> <li>• PID—CBR-2X100G-PIC</li> </ul> <p>Digital PICs:</p> <ul style="list-style-type: none"> <li>• PID—CBR-DPIC-8X10G</li> <li>• PID—CBR-DPIC-2X100G</li> </ul> <p>Cisco cBR-8 Downstream PHY Module:</p> <ul style="list-style-type: none"> <li>• PID—CBR-D31-DS-MOD</li> </ul> <p>Cisco cBR-8 Upstream PHY Modules:</p> <ul style="list-style-type: none"> <li>• PID—CBR-D31-US-MOD</li> </ul> |



**Note** Do not use DPICs (8X10G and 2x100G) to forward IP traffic, as it may cause buffer exhaustion, leading to line card reload.

The only allowed traffic on a DPIC interface is DEPI, UEPI, and GCP traffic from the Cisco cBR-8 router to Remote PHY devices. Other traffic such as DHCP, SSH, and UTSC should flow via another router, since DPICs cannot be used for normal routing.

## Information About IPv6 ACL—Template ACL

### IPv6 Template ACL

When user profiles are configured using vendor-specific attribute (VSA) Cisco AV-pairs, similar per-user IPv6 ACLs may be replaced by a single template ACL. That is, one ACL represents many similar ACLs. By using IPv6 template ACLs, you can increase the total number of per-user ACLs while minimizing the memory and Ternary Content Addressable Memory (TCAM) resources needed to support the ACLs.

The IPv6 Template ACL feature can create templates using the following ACL fields:

- IPv6 source and destination addresses
- TCP and UDP, including all associated ports (0 through 65535)
- ICMP neighbor discovery advertisements and solicitations
- IPv6 DSCP with specified DSCP values

ACL names are dynamically generated by this feature; for example:

- 6Temp\_#152875854573--Example of a dynamically generated template name for a template ACL parent
- Virtual-Access2.32135#152875854573--Example of a child ACL or an ACL that has not yet been made part of a template.

## How to Enable IPv6 ACL—Template ACL

### Enabling IPv6 Template Processing

#### SUMMARY STEPS

1. **enable**
2. **configure terminal**
3. **access-list template** [*number-of-rules*]
4. **exit**
5. **show access-list template** {**summary** | *aclname* | **exceed** *number* | **tree**}

## DETAILED STEPS

|               | Command or Action                                                                                                                                                                           | Purpose                                                                                                                                                                                                                                                             |
|---------------|---------------------------------------------------------------------------------------------------------------------------------------------------------------------------------------------|---------------------------------------------------------------------------------------------------------------------------------------------------------------------------------------------------------------------------------------------------------------------|
| <b>Step 1</b> | <b>enable</b><br><b>Example:</b><br><pre>Router&gt; enable</pre>                                                                                                                            | Enables privileged EXEC mode. <ul style="list-style-type: none"> <li>• Enter your password if prompted.</li> </ul>                                                                                                                                                  |
| <b>Step 2</b> | <b>configure terminal</b><br><b>Example:</b><br><pre>Router# configure terminal</pre>                                                                                                       | Enters global configuration mode.                                                                                                                                                                                                                                   |
| <b>Step 3</b> | <b>access-list template</b> [ <i>number-of-rules</i> ]<br><b>Example:</b><br><pre>Router(config)# access-list template 50</pre>                                                             | Enables template ACL processing. <ul style="list-style-type: none"> <li>• The example in this task specifies that ACLs with 50 or fewer rules will be considered for template ACL status.</li> <li>• The <i>number-of-rules</i> argument default is 100.</li> </ul> |
| <b>Step 4</b> | <b>exit</b><br><b>Example:</b><br><pre>Router(config)# exit</pre>                                                                                                                           | Exits global configuration mode and places the router in privileged EXEC mode.                                                                                                                                                                                      |
| <b>Step 5</b> | <b>show access-list template</b> { <b>summary</b>   <i>aclname</i>   <b>exceed</b> <i>number</i>   <b>tree</b> }<br><b>Example:</b><br><pre>Router# show access-list template summary</pre> | Displays information about ACL templates.                                                                                                                                                                                                                           |

## Configuration Examples for IPv6 ACL—Template ACL

### Example: IPv6 Template ACL Processing

In this example, the contents of ACL1 and ACL2 are the same, but the names are different:

```
ipv6 access-list extended ACL1 (PeerIP: 2001:1::1/64)
permit igmp any                2003:1::1/64
permit icmp 2002:5::B/64      any
permit udp any                host 2004:1::5
permit udp any                host 2002:2BC::a
permit icmp host 2001:BC::7    host 2003:3::7
ipv6 access-list extended ACL2 (PeerIP: 2007:2::7/64)
permit igmp any                2003:1::1/64
permit icmp 2002:5::B/64      any
permit udp any                host 2004:1::5
```



```

permit udp any host 2002:2BC::a
permit icmp host 2001:BC::7 host 2003:3::7

```

The template for these ACLs is as follows:

```

ipv6 access-list extended Template_1
permit igmp any 2003:1::1/64
permit icmp 2002:5::B/64 any
permit udp any host 2004:1::5
permit udp any host 2002:2BC::a
permit icmp host 2001:BC::7 host 2003:3::7

```

## Additional References

### Related Documents

| Related Topic                    | Document Title                          |
|----------------------------------|-----------------------------------------|
| IPv6 addressing and connectivity | <i>IPv6 Configuration Guide</i>         |
| IPv6 commands                    | <i>Cisco IOS IPv6 Command Reference</i> |
| Cisco IOS IPv6 features          | <i>Cisco IOS IPv6 Feature Mapping</i>   |

### Standards and RFCs

| Standard/RFC  | Title            |
|---------------|------------------|
| RFCs for IPv6 | <i>IPv6 RFCs</i> |

### MIBs

To locate and download MIBs for selected platforms, Cisco IOS releases, and feature sets, use Cisco MIB Locator found at the following URL:

<http://www.cisco.com/go/mibs>

### Technical Assistance

| Description                                                                                                                                                                                                                                                                                                                                                                           | Link                                                                                                              |
|---------------------------------------------------------------------------------------------------------------------------------------------------------------------------------------------------------------------------------------------------------------------------------------------------------------------------------------------------------------------------------------|-------------------------------------------------------------------------------------------------------------------|
| The Cisco Support and Documentation website provides online resources to download documentation, software, and tools. Use these resources to install and configure the software and to troubleshoot and resolve technical issues with Cisco products and technologies. Access to most tools on the Cisco Support and Documentation website requires a Cisco.com user ID and password. | <a href="http://www.cisco.com/cisco/web/support/index.html">http://www.cisco.com/cisco/web/support/index.html</a> |

## Feature Information for IPv6 Template ACL

Use Cisco Feature Navigator to find information about the platform support and software image support. Cisco Feature Navigator enables you to determine which software images support a specific software release, feature set, or platform. To access Cisco Feature Navigator, go to the <https://cfnng.cisco.com/> link. An account on the Cisco.com page is not required.



**Note** The following table lists the software release in which a given feature is introduced. Unless noted otherwise, subsequent releases of that software release train also support that feature.

*Table 265: Feature Information for IPv6 Template ACL*

| Feature Name      | Releases                 | Feature Information                                                                                            |
|-------------------|--------------------------|----------------------------------------------------------------------------------------------------------------|
| IPv6 Access Lists | Cisco IOS XE Fuji 16.7.1 | This feature was integrated into Cisco IOS XE Fuji 16.7.1 on the Cisco cBR Series Converged Broadband Routers. |



## CHAPTER 82

# IPv6 ACL Extensions for Hop by Hop Filtering

The IPv6 ACL Extensions for Hop by Hop Filtering feature allows you to control IPv6 traffic that might contain hop-by-hop extension headers. You can configure an access control list (ACL) to deny all hop-by-hop traffic or to selectively permit traffic based on protocol.

Your software release may not support all the features that are documented in this module. For the latest feature information and caveats, see the release notes for your platform and software release. The Feature Information Table at the end of this document provides information about the documented features and lists the releases in which each feature is supported.

Use Cisco Feature Navigator to find information about platform support and Cisco software image support. To access Cisco Feature Navigator, go to <http://tools.cisco.com/ITDIT/CFN/>. An account on <http://www.cisco.com/> is not required.

### Contents

- [Hardware Compatibility Matrix for the Cisco cBR Series Routers, on page 1279](#)
- [Information About IPv6 ACL Extensions for Hop by Hop Filtering, on page 1281](#)
- [How to Configure IPv6 ACL Extensions for Hop by Hop Filtering, on page 1281](#)
- [Configuration Example for IPv6 ACL Extensions for Hop by Hop Filtering, on page 1282](#)
- [Additional References, on page 1283](#)
- [Feature Information for IPv6 ACL Extensions for Hop by Hop Filtering, on page 1284](#)

## Hardware Compatibility Matrix for the Cisco cBR Series Routers



---

**Note** The hardware components that are introduced in a given Cisco IOS-XE Release are supported in all subsequent releases unless otherwise specified.

---

Table 266: Hardware Compatibility Matrix for the Cisco cBR Series Routers

| Cisco CMTS Platform                    | Processor Engine                                                                                                                                                                                  | Interface Cards                                                                                                                                                                                                                                                                                                                                                                                                                                                                                                                                                                                                                                                                                                                                                                                 |
|----------------------------------------|---------------------------------------------------------------------------------------------------------------------------------------------------------------------------------------------------|-------------------------------------------------------------------------------------------------------------------------------------------------------------------------------------------------------------------------------------------------------------------------------------------------------------------------------------------------------------------------------------------------------------------------------------------------------------------------------------------------------------------------------------------------------------------------------------------------------------------------------------------------------------------------------------------------------------------------------------------------------------------------------------------------|
| Cisco cBR-8 Converged Broadband Router | <p><b>Cisco IOS-XE Release 16.5.1 and Later Releases</b></p> <p>Cisco cBR-8 Supervisor:</p> <ul style="list-style-type: none"> <li>• PID—CBR-SUP-250G</li> <li>• PID—CBR-CCAP-SUP-160G</li> </ul> | <p><b>Cisco IOS-XE Release 16.5.1 and Later Releases</b></p> <p>Cisco cBR-8 CCAP Line Cards:</p> <ul style="list-style-type: none"> <li>• PID—CBR-LC-8D30-16U30</li> <li>• PID—CBR-LC-8D31-16U30</li> <li>• PID—CBR-RF-PIC</li> <li>• PID—CBR-RF-PROT-PIC</li> <li>• PID—CBR-CCAP-LC-40G</li> <li>• PID—CBR-CCAP-LC-40G-R</li> <li>• PID—CBR-CCAP-LC-G2-R</li> <li>• PID—CBR-SUP-8X10G-PIC</li> <li>• PID—CBR-2X100G-PIC</li> </ul> <p>Digital PICs:</p> <ul style="list-style-type: none"> <li>• PID—CBR-DPIC-8X10G</li> <li>• PID—CBR-DPIC-2X100G</li> </ul> <p>Cisco cBR-8 Downstream PHY Module:</p> <ul style="list-style-type: none"> <li>• PID—CBR-D31-DS-MOD</li> </ul> <p>Cisco cBR-8 Upstream PHY Modules:</p> <ul style="list-style-type: none"> <li>• PID—CBR-D31-US-MOD</li> </ul> |



**Note** Do not use DPICs (8X10G and 2x100G) to forward IP traffic, as it may cause buffer exhaustion, leading to line card reload.

The only allowed traffic on a DPIC interface is DEPI, UEPI, and GCP traffic from the Cisco cBR-8 router to Remote PHY devices. Other traffic such as DHCP, SSH, and UTSC should flow via another router, since DPICs cannot be used for normal routing.

# Information About IPv6 ACL Extensions for Hop by Hop Filtering

## ACLs and Traffic Forwarding

IPv6 access control lists (ACLs) determine what traffic is blocked and what traffic is forwarded at device interfaces. ACLs allow filtering based on source and destination addresses, inbound and outbound to a specific interface. Use the **ipv6 access-list** command to define an IPv6 ACL, and the **deny** and **permit** commands to configure its conditions.

The IPv6 ACL Extensions for Hop by Hop Filtering feature implements RFC 2460 to support traffic filtering in any upper-layer protocol type.

## How to Configure IPv6 ACL Extensions for Hop by Hop Filtering

### Configuring IPv6 ACL Extensions for Hop by Hop Filtering

#### SUMMARY STEPS

1. **enable**
2. **configure terminal**
3. **ipv6 access-list** *access-list-name*
4. **permit** *protocol* {*source-ipv6-prefix/prefix-length* | **any** | **host** *source-ipv6-address* | **auth**} [*operator* [*port-number*]] {*destination-ipv6-prefix/prefix-length* | **any** | **host** *destination-ipv6-address* | **auth**} [*operator* [*port-number*]] [**dest-option-type** [*header-number* | *header-type*]] [**dscp** *value*] [**flow-label** *value*] [**fragments**] [**hbh**] [**log**] [**log-input**] [**mobility**] [**mobility-type** [*mh-number* | *mh-type*]] [**reflect** *name*] [**timeout** *value*] [**routing**] [**routing-type** *routing-number*] [**sequence** *value*] [**time-range** *name*]
5. **deny** *protocol* {*source-ipv6-prefix/prefix-length* | **any** | **host** *source-ipv6-address* / **auth**} [*operator* [*port-number*]] {*destination-ipv6-prefix/prefix-length* | **any** | **host** *destination-ipv6-address* | **auth**} [*operator* [*port-number*]] [**dest-option-type** [*header-number* | *header-type*]] [**dscp** *value*] [**flow-label** *value*] [**fragments**] [**hbh**] [**log**] [**log-input**] [**mobility**] [**mobility-type** [*mh-number* | *mh-type*]] [**routing**] [**routing-type** *routing-number*] [**sequence** *value*] [**time-range** *name*] [**undetermined-transport**]
6. **end**

#### DETAILED STEPS

|        | Command or Action                                                          | Purpose                                                                                                            |
|--------|----------------------------------------------------------------------------|--------------------------------------------------------------------------------------------------------------------|
| Step 1 | <b>enable</b><br><b>Example:</b><br>Device> enable                         | Enables privileged EXEC mode. <ul style="list-style-type: none"> <li>• Enter your password if prompted.</li> </ul> |
| Step 2 | <b>configure terminal</b><br><b>Example:</b><br>Device# configure terminal | Enters global configuration mode.                                                                                  |

|               | Command or Action                                                                                                                                                                                                                                                                                                                                                                                                                                                                                                                                                                                                                                                                                                                                                                                                                                                                                                                                    | Purpose                                                             |
|---------------|------------------------------------------------------------------------------------------------------------------------------------------------------------------------------------------------------------------------------------------------------------------------------------------------------------------------------------------------------------------------------------------------------------------------------------------------------------------------------------------------------------------------------------------------------------------------------------------------------------------------------------------------------------------------------------------------------------------------------------------------------------------------------------------------------------------------------------------------------------------------------------------------------------------------------------------------------|---------------------------------------------------------------------|
| <b>Step 3</b> | <b>ipv6 access-list</b> <i>access-list-name</i><br><b>Example:</b><br>Device(config)# ipv6 access-list hbh-acl                                                                                                                                                                                                                                                                                                                                                                                                                                                                                                                                                                                                                                                                                                                                                                                                                                       | Defines an IPv6 ACL and enters IPv6 access list configuration mode. |
| <b>Step 4</b> | <b>permit</b> <i>protocol</i> { <i>source-ipv6-prefix/prefix-length</i>   <b>any</b>   <b>host</b> <i>source-ipv6-address</i>   <b>auth</b> } [ <i>operator</i> [ <i>port-number</i> ]] { <i>destination-ipv6-prefix/prefix-length</i>   <b>any</b>   <b>host</b> <i>destination-ipv6-address</i>   <b>auth</b> } [ <i>operator</i> [ <i>port-number</i> ]] [ <b>dest-option-type</b> [ <i>header-number</i>   <i>header-type</i> ]] [ <b>dscp</b> <i>value</i> ] [ <b>flow-label</b> <i>value</i> ] [ <b>fragments</b> ] [ <b>hbh</b> ] [ <b>log</b> ] [ <b>log-input</b> ] [ <b>mobility</b> ] [ <b>mobility-type</b> [ <i>mh-number</i>   <i>mh-type</i> ]] [ <b>reflect</b> <i>name</i> [ <b>timeout</b> <i>value</i> ]] [ <b>routing</b> ] [ <b>routing-type</b> <i>routing-number</i> ] [ <b>sequence</b> <i>value</i> ] [ <b>time-range</b> <i>name</i> ]<br><b>Example:</b><br>Device(config-ipv6-acl)# permit icmp any any dest-option-type | Sets permit conditions for the IPv6 ACL.                            |
| <b>Step 5</b> | <b>deny</b> <i>protocol</i> { <i>source-ipv6-prefix/prefix-length</i>   <b>any</b>   <b>host</b> <i>source-ipv6-address</i>   <b>auth</b> } [ <i>operator</i> [ <i>port-number</i> ]] { <i>destination-ipv6-prefix/prefix-length</i>   <b>any</b>   <b>host</b> <i>destination-ipv6-address</i>   <b>auth</b> } [ <i>operator</i> [ <i>port-number</i> ]] [ <b>dest-option-type</b> [ <i>header-number</i>   <i>header-type</i> ]] [ <b>dscp</b> <i>value</i> ] [ <b>flow-label</b> <i>value</i> ] [ <b>fragments</b> ] [ <b>hbh</b> ] [ <b>log</b> ] [ <b>log-input</b> ] [ <b>mobility</b> ] [ <b>mobility-type</b> [ <i>mh-number</i>   <i>mh-type</i> ]] [ <b>routing</b> ] [ <b>routing-type</b> <i>routing-number</i> ] [ <b>sequence</b> <i>value</i> ] [ <b>time-range</b> <i>name</i> ] [ <b>undetermined-transport</b> ]<br><b>Example:</b><br>Device(config-ipv6-acl)# deny icmp any any dest-option-type                                 | Sets deny conditions for the IPv6 ACL.                              |
| <b>Step 6</b> | <b>end</b><br><b>Example:</b><br>Device (config-ipv6-acl)# end                                                                                                                                                                                                                                                                                                                                                                                                                                                                                                                                                                                                                                                                                                                                                                                                                                                                                       | Returns to privileged EXEC configuration mode.                      |

## Configuration Example for IPv6 ACL Extensions for Hop by Hop Filtering

### Example: IPv6 ACL Extensions for Hop by Hop Filtering

```
Device(config)# ipv6 access-list hbh_acl
Device(config-ipv6-acl)# permit tcp any any hbh
```

```

Device(config-ipv6-acl)# permit tcp any any
Device(config-ipv6-acl)# permit udp any any
Device(config-ipv6-acl)# permit udp any any hbh
Device(config-ipv6-acl)# permit hbh any any
Device(config-ipv6-acl)# permit any any
Device(config-ipv6-acl)# hardware statistics
Device(config-ipv6-acl)# exit

! Assign an IP address and add the ACL on the interface.

Device(config)# interface TenGigabitEthernet4/1/0
Device(config-if)# ipv6 address 1001::1/64
Device(config-if)# ipv6 traffic-filter hbh_acl in
Device(config-if)# exit
Device(config)# exit
Device# clear counters
Clear "show interface" counters on all interfaces [confirm]
Device#

! Verify the configurations.

Device# show running-config interface TenGigabitEthernet4/1/0

Building configuration...

Current configuration : 114 bytes
!
interface TenGigabitEthernet4/1/0
no switchport
ipv6 address 1001::1/64
ipv6 traffic-filter hbh_acl
end

```

## Additional References

### Related Documents

| Related Topic                    | Document Title                          |
|----------------------------------|-----------------------------------------|
| IPv6 addressing and connectivity | <i>IPv6 Configuration Guide</i>         |
| IPv6 commands                    | <i>Cisco IOS IPv6 Command Reference</i> |
| Cisco IOS IPv6 features          | <i>Cisco IOS IPv6 Feature Mapping</i>   |

### Standards and RFCs

| Standard/RFC  | Title            |
|---------------|------------------|
| RFCs for IPv6 | <i>IPv6 RFCs</i> |

**MIBs**

To locate and download MIBs for selected platforms, Cisco IOS releases, and feature sets, use Cisco MIB Locator found at the following URL:

<http://www.cisco.com/go/mibs>

**Technical Assistance**

| Description                                                                                                                                                                                                                                                                                                                                                                           | Link                                                                                                              |
|---------------------------------------------------------------------------------------------------------------------------------------------------------------------------------------------------------------------------------------------------------------------------------------------------------------------------------------------------------------------------------------|-------------------------------------------------------------------------------------------------------------------|
| The Cisco Support and Documentation website provides online resources to download documentation, software, and tools. Use these resources to install and configure the software and to troubleshoot and resolve technical issues with Cisco products and technologies. Access to most tools on the Cisco Support and Documentation website requires a Cisco.com user ID and password. | <a href="http://www.cisco.com/cisco/web/support/index.html">http://www.cisco.com/cisco/web/support/index.html</a> |

## Feature Information for IPv6 ACL Extensions for Hop by Hop Filtering

Use Cisco Feature Navigator to find information about the platform support and software image support. Cisco Feature Navigator enables you to determine which software images support a specific software release, feature set, or platform. To access Cisco Feature Navigator, go to the <https://cfng.cisco.com/> link. An account on the Cisco.com page is not required.



**Note** The following table lists the software release in which a given feature is introduced. Unless noted otherwise, subsequent releases of that software release train also support that feature.

**Table 267: Feature Information for IPv6 ACL Extensions for Hop by Hop Filtering**

| Feature Name      | Releases                 | Feature Information                                                                                           |
|-------------------|--------------------------|---------------------------------------------------------------------------------------------------------------|
| IPv6 access lists | Cisco IOS XE Fuji 16.7.1 | This feature was integrated into Cisco IOS XE Fuji 16.7.1 on theCisco cBR Series Converged Broadband Routers. |





## PART IX

# Application—Voice and Video Configuration

- [Unique Device Identifier Retrieval](#) , on page 1287
- [Advanced-Mode DOCSIS Set-Top Gateway 1.2 for the Cisco CMTS Routers](#), on page 1295
- [Cisco Network Registrar for the Cisco CMTS Routers](#), on page 1325





## CHAPTER 83

# Unique Device Identifier Retrieval

---

The Unique Device Identifier (UDI) Retrieval feature provides the ability to retrieve and display the UDI information from any Cisco product that has electronically stored such identity information.

Your software release may not support all the features that are documented in this module. For the latest feature information and caveats, see the release notes for your platform and software release. The Feature Information Table at the end of this document provides information about the documented features and lists the releases in which each feature is supported.

Use Cisco Feature Navigator to find information about platform support and Cisco software image support. To access Cisco Feature Navigator, go to <http://tools.cisco.com/ITDIT/CFN/>. An account on <http://www.cisco.com/> is not required.

### Contents

- [Hardware Compatibility Matrix for the Cisco cBR Series Routers, on page 1287](#)
- [Unique Device Identifier Overview, on page 1289](#)
- [Benefits of the Unique Device Identifier Retrieval Feature, on page 1289](#)
- [Retrieving the Unique Device Identifier, on page 1289](#)
- [Troubleshooting Tips, on page 1292](#)
- [Additional References, on page 1293](#)
- [Feature Information for Unique Device Identifier Retrieval , on page 1293](#)

## Hardware Compatibility Matrix for the Cisco cBR Series Routers



---

**Note** The hardware components that are introduced in a given Cisco IOS-XE Release are supported in all subsequent releases unless otherwise specified.

---

Table 268: Hardware Compatibility Matrix for the Cisco cBR Series Routers

| Cisco CMTS Platform                    | Processor Engine                                                                                                                                                                                  | Interface Cards                                                                                                                                                                                                                                                                                                                                                                                                                                                                                                                                                                                                                                                                                                                                                                                 |
|----------------------------------------|---------------------------------------------------------------------------------------------------------------------------------------------------------------------------------------------------|-------------------------------------------------------------------------------------------------------------------------------------------------------------------------------------------------------------------------------------------------------------------------------------------------------------------------------------------------------------------------------------------------------------------------------------------------------------------------------------------------------------------------------------------------------------------------------------------------------------------------------------------------------------------------------------------------------------------------------------------------------------------------------------------------|
| Cisco cBR-8 Converged Broadband Router | <p><b>Cisco IOS-XE Release 16.5.1 and Later Releases</b></p> <p>Cisco cBR-8 Supervisor:</p> <ul style="list-style-type: none"> <li>• PID—CBR-SUP-250G</li> <li>• PID—CBR-CCAP-SUP-160G</li> </ul> | <p><b>Cisco IOS-XE Release 16.5.1 and Later Releases</b></p> <p>Cisco cBR-8 CCAP Line Cards:</p> <ul style="list-style-type: none"> <li>• PID—CBR-LC-8D30-16U30</li> <li>• PID—CBR-LC-8D31-16U30</li> <li>• PID—CBR-RF-PIC</li> <li>• PID—CBR-RF-PROT-PIC</li> <li>• PID—CBR-CCAP-LC-40G</li> <li>• PID—CBR-CCAP-LC-40G-R</li> <li>• PID—CBR-CCAP-LC-G2-R</li> <li>• PID—CBR-SUP-8X10G-PIC</li> <li>• PID—CBR-2X100G-PIC</li> </ul> <p>Digital PICs:</p> <ul style="list-style-type: none"> <li>• PID—CBR-DPIC-8X10G</li> <li>• PID—CBR-DPIC-2X100G</li> </ul> <p>Cisco cBR-8 Downstream PHY Module:</p> <ul style="list-style-type: none"> <li>• PID—CBR-D31-DS-MOD</li> </ul> <p>Cisco cBR-8 Upstream PHY Modules:</p> <ul style="list-style-type: none"> <li>• PID—CBR-D31-US-MOD</li> </ul> |



**Note** Do not use DPICs (8X10G and 2x100G) to forward IP traffic, as it may cause buffer exhaustion, leading to line card reload.

The only allowed traffic on a DPIC interface is DEPI, UEPI, and GCP traffic from the Cisco cBR-8 router to Remote PHY devices. Other traffic such as DHCP, SSH, and UTSC should flow via another router, since DPICs cannot be used for normal routing.

# Unique Device Identifier Overview

Each identifiable product is an entity, as defined by the Entity MIB (RFC-2737) and its supporting documents. Some entities, such as a chassis, will have sub-entities like slots. An Ethernet switch might be a member of a super-entity like a stack. Most Cisco entities that can be ordered leave the factory with an assigned UDI. The UDI information is printed on a label that is affixed to the physical hardware device, and it is also stored electronically on the device in order to facilitate remote retrieval.

A UDI consists of the following elements:

- Product identifier (PID)
- Version identifier (VID)
- Serial number (SN)

The PID is the name by which the product can be ordered; it has been historically called the “Product Name” or “Part Number.” This is the identifier that one would use to order an exact replacement part.

The VID is the version of the product. Whenever a product has been revised, the VID will be incremented. The VID is incremented according to a rigorous process derived from Telcordia GR-209-CORE, an industry guideline that governs product change notices.

The SN is the vendor-unique serialization of the product. Each manufactured product will carry a unique serial number assigned at the factory, which cannot be changed in the field. This is the means by which to identify an individual, specific instance of a product.

## Benefits of the Unique Device Identifier Retrieval Feature

- Identifies individual Cisco products in your networks.
- Reduces operating expenses for asset management through simple, cross-platform, consistent identification of Cisco products.
- Identifies PIDs for replaceable products.
- Facilitates discovery of products subject to recall or revision.
- Automates Cisco product inventory (capital and asset management).
- Provides a mechanism to determine the entitlement level of a Cisco product for repair and replacement service.

### Product Item Descriptor for Cable Products

For information on the Product Item Descriptor (PID), see the product hardware installation guide available on Cisco.com.

## Retrieving the Unique Device Identifier

To use UDI retrieval, the Cisco product in use must be UDI-enabled. A UDI-enabled Cisco product supports five required Entity MIB objects. The five Entity MIB v2 (RFC-2737) objects are:

- entPhysicalName
- entPhysicalDescr
- entPhysicalModelName

- entPhysicalHardwareRev
- entPhysicalSerialNum

Although the **show inventory** command may be available, using that command on devices that are not UDI-enabled will likely produce no output.

Enter the **show inventory** command to retrieve and display information about all of the Cisco products installed in the networking device that are assigned a PID, VID, and SN. If a Cisco entity is not assigned a PID, that entity is not retrieved or displayed.

```
Router# show inventory

NAME: "Chassis", DESCR: "Cisco cBR-8 CCAP Chassis"
PID: CBR-8-CCAP-CHASS , VID: V01, SN: FXS1739Q0PR

NAME: "clc 3", DESCR: "Cisco cBR CCAP Line Card"
PID: CBR-CCAP-LC-40G , VID: V01, SN: TEST1234567

NAME: "Cable PHY Module", DESCR: "CLC Downstream PHY Module 3/0"
PID: CBR-D30-DS-MOD , VID: V01, SN: CAT1725E1BZ

NAME: "Cable PHY Module", DESCR: "CLC Downstream PHY Module 3/1"
PID: CBR-D30-DS-MOD , VID: V01, SN: CAT1725E1AT

NAME: "Cable PHY Module", DESCR: "CLC Upstream PHY Module 3/2"
PID: CBR-D30-US-MOD , VID: V01, SN: CAT1717E0FF

NAME: "sup 1", DESCR: "Cisco cBR CCAP Supervisor Card"
PID: CBR-CCAP-SUP-60G , VID: V01, SN: CAT1824E0MT

NAME: "harddisk 5/1", DESCR: "Hard Disk"
PID: UGB88RTB100HE3-BCU-DID, VID: , SN: 11000066829

NAME: "sup-pic 5/1", DESCR: "Cisco cBR CCAP Supervisor Card PIC"
PID: CBR-SUP-8X10G-PIC , VID: V01, SN: CAT1720E0F4

NAME: "SFP+ module 5/1/0", DESCR: "iNSI xcvr"
PID: SFP+ 10GBASE-SR , VID: A , SN: FNS172720X6

NAME: "SFP+ module 5/1/1", DESCR: "iNSI xcvr"
PID: SFP+ 10GBASE-LR , VID: A , SN: UGT085P

NAME: "SFP+ module 5/1/2", DESCR: "iNSI xcvr"
PID: SFP+ 10GBASE-LR , VID: A , SN: UGT087Z

NAME: "SFP+ module 5/1/3", DESCR: "iNSI xcvr"
PID: SFP+ 10GBASE-SR , VID: G4.1, SN: AVD1729A38T

NAME: "SFP+ module 5/1/7", DESCR: "iNSI xcvr"
PID: 10GE ZR , VID: A , SN: FNS11300AUH

NAME: "Power Supply Module 0", DESCR: "Cisco cBR CCAP AC Power Supply"
PID: PWR-3KW-AC-V2 , VID: V02, SN: DTM17370345

NAME: "Power Supply Module 2", DESCR: "Cisco cBR CCAP AC Power Supply"
PID: PWR-3KW-AC-V2 , VID: V02, SN: DTM173702KF
```

For diagnostic purposes, the **show inventory** command can be used with the **raw** keyword to display every RFC 2737 entity including those without a PID, UDI, or other physical identification.



**Note** The **raw** keyword option is primarily intended for troubleshooting problems with the **show inventory** command itself.

```
Router# show inventory raw

NAME: "Chassis", DESCR: "Cisco cBR-8 CCAP Chassis"
PID: CBR-8-CCAP-CHASS , VID: V01, SN: FXS1739Q0PR

NAME: "slot 0/0", DESCR: "Chassis Slot"
PID: , VID: , SN:

NAME: "slot 0/1", DESCR: "Chassis Slot"
PID: , VID: , SN:

NAME: "slot 1/0", DESCR: "Chassis Slot"
PID: , VID: , SN:

NAME: "slot 1/1", DESCR: "Chassis Slot"
PID: , VID: , SN:

NAME: "slot 2/0", DESCR: "Chassis Slot"
PID: , VID: , SN:

NAME: "slot 2/1", DESCR: "Chassis Slot"
PID: , VID: , SN:

NAME: "slot 3/0", DESCR: "Chassis Slot"
PID: , VID: , SN:

NAME: "clc 3", DESCR: "Cisco cBR CCAP Line Card"
PID: CBR-CCAP-LC-40G , VID: V01, SN: TEST1234567

NAME: "12_CUR: Sens 3/0", DESCR: "12_CUR: Sens"
PID: , VID: , SN:

NAME: "12_CUR: Vin 3/1", DESCR: "12_CUR: Vin"
PID: , VID: , SN:

NAME: "12_CUR: ADin 3/2", DESCR: "12_CUR: ADin"
PID: , VID: , SN:

NAME: "G0_CUR: Sens 3/3", DESCR: "G0_CUR: Sens"
PID: , VID: , SN:

NAME: "G0_CUR: Vin 3/4", DESCR: "G0_CUR: Vin"
PID: , VID: , SN:

NAME: "G0_CUR: ADin 3/5", DESCR: "G0_CUR: ADin"
PID: , VID: , SN:

NAME: "G1_CUR: Sens 3/6", DESCR: "G1_CUR: Sens"
PID: , VID: , SN:

NAME: "G1_CUR: Vin 3/7", DESCR: "G1_CUR: Vin"
PID: , VID: , SN:

NAME: "G1_CUR: ADin 3/8", DESCR: "G1_CUR: ADin"
PID: , VID: , SN:

NAME: "LB_CUR: Sens 3/9", DESCR: "LB_CUR: Sens"
```

```

PID:                , VID:      , SN:

NAME: "LB_CUR: Vin 3/10", DESCR: "LB_CUR: Vin"
PID:                , VID:      , SN:

NAME: "LB_CUR: ADin 3/11", DESCR: "LB_CUR: ADin"
PID:                , VID:      , SN:

NAME: "Temp: CAPRICA 3/12", DESCR: "Temp: CAPRICA"
PID:                , VID:      , SN:

NAME: "Temp: BASESTAR 3/13", DESCR: "Temp: BASESTAR"
PID:                , VID:      , SN:

NAME: "Temp: RAIDER 3/14", DESCR: "Temp: RAIDER"
PID:                , VID:      , SN:

NAME: "Temp: CPU 3/15", DESCR: "Temp: CPU"
PID:                , VID:      , SN:

NAME: "Temp: INLET 3/16", DESCR: "Temp: INLET"
PID:                , VID:      , SN:

NAME: "Temp: OUTLET 3/17", DESCR: "Temp: OUTLET"
PID:                , VID:      , SN:

NAME: "Temp: DIGITAL 3/18", DESCR: "Temp: DIGITAL"
PID:                , VID:      , SN:

NAME: "Temp: UPX 3/19", DESCR: "Temp: UPX"
PID:                , VID:      , SN:

```

## Troubleshooting Tips

If any of the Cisco products do not have an assigned PID, the output may display incorrect PIDs and the VID and SN elements may be missing, as in the following example.

```

NAME: "POS3/0/0", DESCR: "Skystone 4302 Sonet Framer"

PID: FastEthernet, VID: , SN:

NAME: "Serial1/0", DESCR: "M4T"

PID: M4T                , VID:      , SN:

```

In the sample output, the PID is exactly the same as the product description. The UDI is designed for use with new Cisco products that have a PID assigned. UDI information on older Cisco products is not always reliable.



## Additional References

### Related Documents

| Related Topic                                  | Document Title                                                           |
|------------------------------------------------|--------------------------------------------------------------------------|
| Information about managing configuration files | <a href="#">Cisco IOS Configuration Fundamentals Configuration Guide</a> |
| Commands for showing interface statistics      | <a href="#">Cisco IOS Interface Command Reference</a>                    |

### Standards and RFCs

| Standard/RFC | Title                         |
|--------------|-------------------------------|
| RFC 2737     | <i>Entity MIB (Version 2)</i> |

### MIBs

| MIB                    | MIBs Link                                                                                                                                                                                                              |
|------------------------|------------------------------------------------------------------------------------------------------------------------------------------------------------------------------------------------------------------------|
| CISCO-ENTITY-ASSET-MIB | To locate and download MIBs for selected platforms, Cisco IOS releases, and feature sets, use Cisco MIB Locator found at the following URL:<br><a href="http://www.cisco.com/go/mibs">http://www.cisco.com/go/mibs</a> |

### Technical Assistance

| Description                                                                                                                                                                                                                                                                                                                                                                                                                                                                                                                                                             | Link                                                                                                              |
|-------------------------------------------------------------------------------------------------------------------------------------------------------------------------------------------------------------------------------------------------------------------------------------------------------------------------------------------------------------------------------------------------------------------------------------------------------------------------------------------------------------------------------------------------------------------------|-------------------------------------------------------------------------------------------------------------------|
| <p>The Cisco Support website provides extensive online resources, including documentation and tools for troubleshooting and resolving technical issues with Cisco products and technologies.</p> <p>To receive security and technical information about your products, you can subscribe to various services, such as the Product Alert Tool (accessed from Field Notices), the Cisco Technical Services Newsletter, and Really Simple Syndication (RSS) Feeds.</p> <p>Access to most tools on the Cisco Support website requires a Cisco.com user ID and password.</p> | <a href="http://www.cisco.com/cisco/web/support/index.html">http://www.cisco.com/cisco/web/support/index.html</a> |

## Feature Information for Unique Device Identifier Retrieval

Use Cisco Feature Navigator to find information about the platform support and software image support. Cisco Feature Navigator enables you to determine which software images support a specific software release,

feature set, or platform. To access Cisco Feature Navigator, go to the <https://cfng.cisco.com/> link. An account on the Cisco.com page is not required.



**Note** The following table lists the software release in which a given feature is introduced. Unless noted otherwise, subsequent releases of that software release train also support that feature.

**Table 269: Feature Information for Unique Device Identifier Retrieval**

| Feature Name                       | Releases                    | Feature Information                                                                                               |
|------------------------------------|-----------------------------|-------------------------------------------------------------------------------------------------------------------|
| Unique Device Identifier Retrieval | Cisco IOS XE Everest 16.6.1 | This feature was integrated into Cisco IOS XE Everest 16.6.1 on the Cisco cBR Series Converged Broadband Routers. |



## CHAPTER 84

# Advanced-Mode DOCSIS Set-Top Gateway 1.2 for the Cisco CMTS Routers

---

The Advanced-Mode DOCSIS Set-Top Gateway (A-DSG) Issue 1.2 introduces support for the latest DOCSIS Set-Top specification from CableLabs™, to include the following enhancements:

- *DOCSIS Set-top Gateway (DSG) Interface Specification*
- A-DSG 1.2 introduces support for the DOCS-DSG-IF MIB.

Cisco A-DSG 1.2 is certified by CableLabs™, and is a powerful tool in support of latest industry innovations. A-DSG 1.2 offers substantial support for enhanced DOCSIS implementation in the broadband cable environment. The set-top box (STB) dynamically learns the overall environment from the Cisco CMTS router, to include MAC address, traffic management rules, and classifiers.

Your software release may not support all the features that are documented in this module. For the latest feature information and caveats, see the release notes for your platform and software release. The Feature Information Table at the end of this document provides information about the documented features and lists the releases in which each feature is supported.

Use Cisco Feature Navigator to find information about platform support and Cisco software image support. To access Cisco Feature Navigator, go to <http://tools.cisco.com/ITDIT/CFN/>. An account on <http://www.cisco.com/> is not required.

### Contents

- [Hardware Compatibility Matrix for the Cisco cBR Series Routers, on page 1296](#)
- [Prerequisites for Advanced-Mode DSG Issue 1.2, on page 1297](#)
- [Restrictions for Advanced-Mode DSG Issue 1.2, on page 1297](#)
- [Information About Advanced-Mode DSG Issue 1.2, on page 1298](#)
- [How to Configure Advanced-Mode DSG Issue 1.2, on page 1300](#)
- [How to Monitor and Debug the Advanced-mode DOCSIS Set-Top Gateway Feature, on page 1317](#)
- [Configuration Examples for Advanced-Mode DSG, on page 1320](#)
- [Additional References, on page 1323](#)
- [Feature Information for Advanced-Mode DSG 1.2 for the Cisco CMTS Routers, on page 1323](#)

# Hardware Compatibility Matrix for the Cisco cBR Series Routers



**Note** The hardware components that are introduced in a given Cisco IOS-XE Release are supported in all subsequent releases unless otherwise specified.

**Table 270: Hardware Compatibility Matrix for the Cisco cBR Series Routers**

| Cisco CMTS Platform                    | Processor Engine                                                                                                                                                                                  | Interface Cards                                                                                                                                                                                                                                                                                                                                                                                                                                                                                                                                                                                                                                                                                                                                                                                 |
|----------------------------------------|---------------------------------------------------------------------------------------------------------------------------------------------------------------------------------------------------|-------------------------------------------------------------------------------------------------------------------------------------------------------------------------------------------------------------------------------------------------------------------------------------------------------------------------------------------------------------------------------------------------------------------------------------------------------------------------------------------------------------------------------------------------------------------------------------------------------------------------------------------------------------------------------------------------------------------------------------------------------------------------------------------------|
| Cisco cBR-8 Converged Broadband Router | <p><b>Cisco IOS-XE Release 16.5.1 and Later Releases</b></p> <p>Cisco cBR-8 Supervisor:</p> <ul style="list-style-type: none"> <li>• PID—CBR-SUP-250G</li> <li>• PID—CBR-CCAP-SUP-160G</li> </ul> | <p><b>Cisco IOS-XE Release 16.5.1 and Later Releases</b></p> <p>Cisco cBR-8 CCAP Line Cards:</p> <ul style="list-style-type: none"> <li>• PID—CBR-LC-8D30-16U30</li> <li>• PID—CBR-LC-8D31-16U30</li> <li>• PID—CBR-RF-PIC</li> <li>• PID—CBR-RF-PROT-PIC</li> <li>• PID—CBR-CCAP-LC-40G</li> <li>• PID—CBR-CCAP-LC-40G-R</li> <li>• PID—CBR-CCAP-LC-G2-R</li> <li>• PID—CBR-SUP-8X10G-PIC</li> <li>• PID—CBR-2X100G-PIC</li> </ul> <p>Digital PICs:</p> <ul style="list-style-type: none"> <li>• PID—CBR-DPIC-8X10G</li> <li>• PID—CBR-DPIC-2X100G</li> </ul> <p>Cisco cBR-8 Downstream PHY Module:</p> <ul style="list-style-type: none"> <li>• PID—CBR-D31-DS-MOD</li> </ul> <p>Cisco cBR-8 Upstream PHY Modules:</p> <ul style="list-style-type: none"> <li>• PID—CBR-D31-US-MOD</li> </ul> |



**Note** Do not use DPICs (8X10G and 2x100G) to forward IP traffic, as it may cause buffer exhaustion, leading to line card reload.

The only allowed traffic on a DPIC interface is DEPI, UEPI, and GCP traffic from the Cisco cBR-8 router to Remote PHY devices. Other traffic such as DHCP, SSH, and UTSC should flow via another router, since DPICs cannot be used for normal routing.

## Prerequisites for Advanced-Mode DSG Issue 1.2

No special equipment or software is needed to use the Advanced-Mode DSG Issue 1.2 feature.

## Restrictions for Advanced-Mode DSG Issue 1.2

This section contains restrictions that are specific to A-DSG 1.2 on a Cisco CMTS router.

### DSG Configuration File Transfer Operations

DSG 1.2 does not support the copying of a DSG configuration file from a TFTP server, file system, or bootflash to the running configuration.

### Multicast Configuration Restrictions

IP multicasting must be configured for correct operation of A-DSG 1.2. Specifically, IP multicast routing must be set in global configuration. Also, IP PIM must be configured on all bundle interfaces of cable interfaces that are to carry multicast traffic.

See the [Configuring the Default Multicast Quality of Service, on page 1300](#) and the [Configuring IP Multicast Operations, on page 1308](#) for additional Multicast information and global configurations supporting DSG.

### NAT for DSG Unicast-only Mapping

A-DSG 1.2 supports multicast IP addressing. However, it also supports unicast IP destination addresses. On the Cisco cBR-8 router, DSG 1.2 support is provided with the configuration of Network Address Translation (NAT) on the router, to include these settings:

- WAN interface(s) are configured with the **ip nat outside** command.
- Cable interface(s) are configured with the **ip nat inside** command.
- For each mapping, additional configuration includes the source static multicast IP address and the unicast IP address.

The unicast IP address is the unicast destination IP address of the DSG packets arriving at the Cisco CMTS router. The multicast IP address is the new destination IP address that is configured to map to one or a set of DSG tunnels.

## PIM and SSM for Multicast

When using Source Specific Multicast (SSM) operation in conjunction with A-DSG 1.2, the following system-wide configuration command must be specified:

- **ip pim ssm**

Refer to the [Configuring IP Multicast Operations, on page 1308](#).

## Subinterfaces

A-DSG 1.2 supports subinterfaces on the Cisco CMTS router.

## Information About Advanced-Mode DSG Issue 1.2

A-DSG 1.2 offers these new or enhanced capabilities:

- A-DSG client and agent modes
- Advanced-mode MIBs supporting DSG 1.2, including the DOCS-DSG-IF-MIB
- Advanced-mode tunnels with increased security
- Cable interface bundling through virtual interface bundling
- Downstream Channel Descriptor
- IP multicast support
- Quality of Service (QoS)

## DSG 1.2 Clients and Agents

A-DSG 1.2 supports the DSG client and agent functions outlined by the CableLabs™ *DOCSIS Set-top Gateway (DSG) Interface Specification*, CM-SP-DSG-I05-050812.

## FQDN Support

You can specify either a fully-qualified domain name (FQDN) or IP address for A-DSG classifier multicast group and source addresses using the **cable dsg cfr** command in global configuration mode. We recommend that you use an FQDN to avoid modification of multicast group and source addresses when network changes are implemented.

This feature allows you to use a hostname (FQDN) in place of the source IP address using the **cable dsg cfr** command. For example, you have two A-DSG tunnel servers, in two locations, sending multicast traffic to the same multicast address. In this scenario, you can specify a hostname for the source IP address and let the DNS server determine which source is sending the multicast traffic.

If you configure an A-DSG classifier with a hostname, the Cisco CMTS router immediately verifies if the hostname can be resolved against an IP address using the local host cache. If not, the router does not enable the classifier until the hostname is resolved. If the hostname cannot be resolved locally, the router performs a DNS query to verify the DSG classifiers.

The FQDN format does not support static Internet Group Management Protocol (IGMP) join requests initiated on the Cisco CMTS router. The IGMP static group IP address created automatically under a bundle interface at the time of A-DSG configuration is not displayed in the **show running-config interface** command output.

To display the A-DSG static groups configured under a bundle interface, use the **show cable dsg static-group bundle** command in privileged EXEC mode.

## DSG Name Process and DNS Query

Every DNS record contains a time to live (TTL) value set by the server administrator, and this may vary from seconds to weeks. The DSG name process supersedes the TTL value criterion to update A-DSG classifiers on the Cisco CMTS router.

The DSG name process enables the Cisco CMTS router to query the DNS server for faster classifier updates. To enable the Cisco CMTS router to perform a DNS query for an A-DSG classifier verification, you must configure one or more DNS servers using the **ip name-server** command in global configuration mode. You can also specify the DNS query interval using the **cable dsg name-update-interval** command in global configuration mode.

During a Cisco IOS software reload or a route processor switchover, the router may fail to query the DNS server if the interfaces are down, and the router may not wait for the interval specified using the **cable dsg name-update-interval** command to perform a DNS query. In this case, for an unresolved hostname, the router automatically performs a DNS query based on a system-defined (15 seconds) interval to facilitate faster DSG classifier updates. You cannot change the system-defined interval.

## A-DSG Forwarding on the Primary Channel

You can disable A-DSG forwarding per primary capable interface using the **cable downstream dsg disable** command in interface configuration mode. Primary capable interfaces include modular, integrated cable interfaces, and Cisco cBR-8 CCAP cable interfaces.

For example, assume the cable interface 7/1/1 has A-DSG enabled and has four modular channels attached to it. However, you want A-DSG forwarding enabled only on two of these four modular channels. You can exclude the channels of your choice using the **cable downstream dsg disable** command. For details on how to disable modular channels, see the [Disabling A-DSG Forwarding on the Primary Channel](#), on page 1317.



---

**Note** If A-DSG downstream forwarding is disabled on a primary capable interface, the router does not create multicast service flows on the primary capable interface and stops sending Downstream Channel Descriptor (DCD) messages.

---

## DOCSIS 3.0 DSG MDF Support

Support for DOCSIS 3.0 DSG Multicast DSID Forwarding (MDF) is introduced using DSG DA-to-DSID Association Entry type, length, value (TLV 13) in the MAC domain descriptor (MDD) message to communicate the association between a downstream service identifier (DSID) and a group MAC address used for DSG tunnel traffic. This is automatically supported on the Cisco CMTS router.

DOCSIS 2.0 hybrid CMs and DOCSIS 3.0 CMs use Dynamic Bonding Change (DBC) to get DSID information from the Cisco CMTS router, whereas DOCSIS 2.0 DSG hybrid embedded CMs and DOCSIS 3.0 DSG embedded CMs get DSID information from the Cisco CMTS router through MDD messages.

To disable MDF capability on all DSG embedded cable modems, including DOCSIS 3.0 DSG and DOCSIS 2.0 DSG hybrid modems, use the **cable multicast mdf-disable** command with the **dsg** keyword in global configuration mode.

## Source Specific Multicast Mapping

Source Specific Multicast (SSM) is a datagram delivery model that best supports one-to-many applications, also known as broadcast applications. SSM is a core networking technology for the Cisco implementation of IP multicast solutions targeted for audio and video broadcast application environments.

The following two Cisco IOS components together support the implementation of SSM:

- Protocol Independent Multicast source-specific mode (PIM-SSM)
- Internet Group Management Protocol Version 3 (IGMPv3)

SSM mapping can be configured on Cisco CMTS routers.

For details on how to configure SSM mapping on a Cisco CMTS router, see the [Source Specific Multicast \(SSM\) Mapping](#) feature guide.

## How to Configure Advanced-Mode DSG Issue 1.2

Advanced-mode DSG Issue 1.2 entails support for DSG tunnel configuration, to include global, WAN-side, and interface-level settings in support of Multicast.

### Configuring the Default Multicast Quality of Service

According to DOCSIS 3.0, you must configure the default multicast quality of service (MQoS) when using the MQoS. This also applies to the DSG, which uses the MQoS by associating a service class name with the tunnel.

If the default MQoS is not configured, the DSG tunnel service class configuration is rejected. Similarly, if no DSG tunnel uses the MQoS, you are prompted to remove the default MQoS.

The CMTS selects the primary downstream channel to forward the multicast traffic when the default MQoS is configured and there is no matching MQoS group configuration. Otherwise, the wideband interface is used to forward the multicast traffic.

#### Procedure

|        | Command or Action                                                                                                | Purpose                                                                                                            |
|--------|------------------------------------------------------------------------------------------------------------------|--------------------------------------------------------------------------------------------------------------------|
| Step 1 | <b>enable</b><br><b>Example:</b><br>Router> enable                                                               | Enables privileged EXEC mode. <ul style="list-style-type: none"> <li>• Enter your password if prompted.</li> </ul> |
| Step 2 | <b>configure terminal</b><br><b>Example:</b><br>Router# configure terminal<br><b>Example:</b><br>Router(config)# | Enters global configuration mode.                                                                                  |



|        | Command or Action                                                                                                                                                                       | Purpose                                              |
|--------|-----------------------------------------------------------------------------------------------------------------------------------------------------------------------------------------|------------------------------------------------------|
| Step 3 | <b>cable multicast group-qos default scn <i>service-class-name</i> aggregate</b><br><b>Example:</b><br><pre>Router(config)# cable multicast group-qos default scn name1 aggregate</pre> | Configures a service class name for the QoS profile. |
| Step 4 | <b>end</b><br><b>Example:</b><br><pre>Router(config)# end</pre>                                                                                                                         | Returns to privileged EXEC mode.                     |

### What to do next



**Note** If you configure or remove the default MQoS while the CMTS is sending multicast traffic, duplicate traffic is generated for approximately 3 minutes (or 3 times the query interval).

## Configuring DSG OPS Under MAC Domain Profile

The DOCSIS Set-Top Gateway (DSG) OPS CLI automatically creates the DSG Tunnel Group (TG) channels to MAC domain when you apply the MAC domain profile with the DSG configuration. Use the following commands to configure DSG globally.

```
cable dsg client-list XXX id-index Y freq 470000
cable dsg vendor-param X vendor Y oui Z
cable dsg timer X Tdsg1 2 Tdsg2 150 Tdsg3 10 Tdsg4 150
cable dsg tg XXX
cable dsg tg XXX default-priority Y
cable dsg tg XXX channel Y priority Z
cable dsg tg XXX channel Y ucid Z
cable dsg tg XXX channel Y vendor-param Z
```

The DSG TG channel generated with the MAC domain profile cannot be removed globally.

```
Router(config)#no cable dsg tg 4500 ch 1
% tg 4500 channel 1 is generated by profile,would not remove it.
CBR(config)#
```

### Configure DSG Under Service Group Profile

```
Router(config)#cable profile service-group Y
Router(config-profile-sg)#mac-domain 0 profile MD0
Router(config-profile-sg-md)# cable downstream dsg ?
chan-list      DSG Channel List Setting
dcd-enable     Enable DSG DCD messages when no enabled rules/tunnels
tg             DSG Tunnel group
timer         DSG Timer Setting
vendor-param   DSG vendor specific parameters
```

## Apply Service Group Under Fiber Node

```
Router(config)#cable fiber-node X
Router(config-fiber-node)#service-group profile Y
```

## Verify DSG TG Configuration

```
Router#show cabl dsg tg
TG      Chan  TG      Rule  Vendor UCID      Service-group  Profile
id      id    state  I/F   pri   Param  list          Profile        chan state
-----
2000    1      en     C1/0/0  0
4500    1      en     C1/0/0  2     2      1 2          SG1            en
4500    2      en
                                0
                                2
                                1 2          SG1            dis
                                --
                                --
```

## Verify Service Group Profile

```
show cable profile service-group <name>
```

## Remove DSG

You can remove the OPS commands by CLI under the MAC domain. Use the following commands:

```
Router#interface Cable1/0/1
Router(config-if)#no cable downstream dsg tg 4500 channel 1
Tunnel group 4500 channel 1 is configured by profile.
Do you want to remove it?[confirm]
(config-if)#
```

or use the following command: **no cable downstream dsg tg 4500 channel 1 force**

## Re-apply DSG Configuration

```
Router#interface Cable1/0/1
Router(config-if)#cable downstream dsg tg 4500 channel 1
Router(config-if)#
```

## Example

```
cable dsg timer 1 Tdsg1 2 Tdsg2 600 Tdsg3 300 Tdsg4 1800
cable dsg chan-list 111 index 1 freq 47000000
cable dsg vendor-param 2 vendor 2 oui 00000B
cable dsg tg 4500
cable dsg tg 4500 channel 1

cable profile service-group SG1
cable bundle 255
mac-domain 0 profile MD1
  downstream sg-channel 2-3 profile DS1 upstream 2-3
  cable downstream dsg chan-list 111
  cable downstream dsg timer 1
  cable downstream dsg vendor-param 2
  cable downstream dsg tg 4500
  cable downstream dsg tg 4500 priority 2
  cable downstream dsg tg 4500 vendor-param 2
  cable downstream dsg tg 4500 ucid 1 2

cable fiber-node 1
  downstream Integrated-Cable 1/0/1
  upstream Upstream-Cable 1/0/0
  downstream sg-channel 0 15 integrated-cable 1/0/1 rf-channel 0 15
```

```

upstream sg-channel 0 7 Upstream-Cable 1/0/0 us-channel 0 7
service-group profile SG1

interface Cable1/0/1
cable mac-domain-profile MD1
cable bundle 255
cable managed fiber-node 1

```

## Configuring Global Tunnel Group Settings for Advanced-Mode DSG 1.2

This procedure configures global and interface-level commands on the Cisco CMTS router to enable DSG tunnel groups. A DSG tunnel group is used to bundle some DSG channels together and associate them to a MAC domain interface.

### Global A-DSG 1.2 Tunnel Settings

This procedure sets and enables global configurations to support both A-DSG 1.2 clients and agents. Additional procedures provide additional settings for these clients and agents.

#### Before you begin

When DOCSIS Set-top Gateway (DSG) is configured to have quality of service (QoS) for tunnel, ensure that the default multicast QoS (MQoS) is also configured. For more information, see [Configuring the Default Multicast Quality of Service, on page 1300](#).



**Note** The DSG tunnel service class configuration is rejected, if default MQoS is not configured.

#### Procedure

|               | Command or Action                                                                                                                                                                   | Purpose                                                                                                            |
|---------------|-------------------------------------------------------------------------------------------------------------------------------------------------------------------------------------|--------------------------------------------------------------------------------------------------------------------|
| <b>Step 1</b> | <b>enable</b><br><b>Example:</b><br>Router> <b>enable</b>                                                                                                                           | Enables privileged EXEC mode. <ul style="list-style-type: none"> <li>• Enter your password if prompted.</li> </ul> |
| <b>Step 2</b> | <b>configure terminal</b><br><b>Example:</b><br>Router# <b>configure terminal</b><br>Router(config)#                                                                                | Enters global configuration mode.                                                                                  |
| <b>Step 3</b> | <b>cable dsg tgroup-id [channelchannel-id  priorityDSG-rule-priority ] [enable disable]</b><br><b>Example:</b><br>Router(config)# <b>cable dsg tg 1 channel 1 priority 1 enable</b> | Command allows the association of a group of tunnels to one or more downstream interfaces on the Cisco CMTS.       |

|               | Command or Action                                                                                                                                                                                                                                      | Purpose                                                                                                                                                                                                                                                                                                |
|---------------|--------------------------------------------------------------------------------------------------------------------------------------------------------------------------------------------------------------------------------------------------------|--------------------------------------------------------------------------------------------------------------------------------------------------------------------------------------------------------------------------------------------------------------------------------------------------------|
| <b>Step 4</b> | <b>cabledsg tg</b> <i>group-id</i> [ <b>channel</b> <i>channel-id</i> [ <b>ucid</b> <i>IDI</i> ]]<br><b>Example:</b><br><pre>Router(config)# cable dsg tg 1 channel 1 ucid 1</pre>                                                                     | Sets the upstream channel or channels to which the DSG 1.2 tunnel applies.                                                                                                                                                                                                                             |
| <b>Step 5</b> | <b>cable dsg tg</b> <i>group-id</i> [ <b>channel</b> <i>channel-id</i> [ <b>vendor-param</b> <i>vendor-group-id</i> ]]<br><b>Example:</b><br><pre>Router(config)# cable dsg tg 1 channel 1 vendor-param 1</pre>                                        | Sets the vendor-specific parameters for upstream DSG 1.2 channels.                                                                                                                                                                                                                                     |
| <b>Step 6</b> | <b>cable dsg vendor-param</b> <i>group-id</i> <b>vendor</b> <i>vendor-index</i><br><b>oui</b> <i>oui</i> <b>value</b> <i>value-in-TLV</i><br><b>Example:</b><br><pre>Router(config)# cable dsg vendor-param 1 vendor 1 oui ABCDEA value 0101AB</pre>   | Configures vendor-specific parameters for A-DSG 1.2. To remove this configuration from the Cisco CMTS, use the no form of this command.                                                                                                                                                                |
| <b>Step 7</b> | <b>cable dsg chan-list</b> <i>list-index</i> <b>index</b> <i>entry-index</i> <b>freq</b> <i>freq</i><br><b>Example:</b><br><pre>Router(config)# cable dsg chan-list 1 index 1 freq 47000000</pre>                                                      | Configures the A-DSG 1.2 downstream channel list. The channel list is a list of DSG channels (downstream frequencies) that set-top boxes can search to find the DSG tunnel appropriate for their operation. To remove the A-DSG 1.2 channel list from the Cisco CMTS, use the no form of this command. |
| <b>Step 8</b> | <b>cable dsg timer inde</b> [ <b>Tdsg1</b> <i>Tdsg1</i> ] [ <b>Tdsg2</b> <i>Tdsg2</i> ] [ <b>Tdsg3</b> <i>Tdsg3</i> ] [ <b>Tdsg4</b> <i>Tdsg4</i> ]<br><b>Example:</b><br><pre>Router(config)# cable dsg timer 1 Tdsg1 1 Tdsg2 2 Tdsg3 3 Tdsg4 4</pre> | Configures the A-DSG 1.2 timer entry to be associated to the downstream channel, and encoded into the Downstream Channel Descriptor (DCD) message. To remove the cable DSG timer from the Cisco CMTS, use the no form of this command.                                                                 |
| <b>Step 9</b> | <b>end</b><br><b>Example:</b><br><pre>Router(config)# end</pre>                                                                                                                                                                                        | Returns to privileged EXEC mode.                                                                                                                                                                                                                                                                       |

### What to do next

#### Troubleshooting Tips

Refer to **debug** and **show** commands in the [How to Monitor and Debug the Advanced-mode DOCSIS Set-Top Gateway Feature](#), on page 1317.

## Adding DSG Tunnel Group to a Subinterface

This procedure adds a DSG tunnel group to a subinterface using the `cable dsg tg group-id` command. After adding the DSG tunnel-group to a subinterface, appropriate IP Internet Group Management Protocol (IGMP) static joins are created and forwarding of DSG traffic begins, if the downstream DSG is configured.

### Before you begin

The downstream DSG should exist to create IGMP static joins.



**Restriction** You can associate a DSG tunnel group to only one subinterface within the same bundle interface.

### Procedure

|        | Command or Action                                                                                                                              | Purpose                                                                                                            |
|--------|------------------------------------------------------------------------------------------------------------------------------------------------|--------------------------------------------------------------------------------------------------------------------|
| Step 1 | <b>enable</b><br><b>Example:</b><br>Router> <b>enable</b>                                                                                      | Enables privileged EXEC mode. <ul style="list-style-type: none"> <li>• Enter your password if prompted.</li> </ul> |
| Step 2 | <b>configureterminal</b><br><b>Example:</b><br>Router# <b>configure terminal</b><br>Router(config)#                                            | Enters global configuration mode.                                                                                  |
| Step 3 | <b>interface bundle</b> <i>bundle-subif-number</i><br><b>Example:</b><br>Router(config)# <b>interface bundle 11.2</b><br>Router(config-subif)# | Specifies the interface bundle and enters the subinterface configuration mode.                                     |
| Step 4 | <b>cable dsg tg</b> <i>group-id</i><br><b>Example:</b><br>Router(config-subif)# <b>cable dsg tg 1</b>                                          | Adds a DSG tunnel group to a subinterface.                                                                         |
| Step 5 | <b>end</b><br><b>Example:</b><br>Router(config-subif)# <b>end</b>                                                                              | Returns to privileged EXEC mode.                                                                                   |

## Configuring the DSG Client Settings for Advanced-Mode DSG 1.2

After the global configurations and DSG client configurations are set for DSG 1.2 on the Cisco CMTS, use the following procedure to continue DSG 1.2 client configurations.



**Restriction** The **in-dcd ignore** option is not supported by DSG-IF-MIBS specification.

### Procedure

|               | Command or Action                                                                                                                                                                                                                                                                                                                                                                                                                                                                      | Purpose                                                                                                                                                                                                                                                                                                                                                    |
|---------------|----------------------------------------------------------------------------------------------------------------------------------------------------------------------------------------------------------------------------------------------------------------------------------------------------------------------------------------------------------------------------------------------------------------------------------------------------------------------------------------|------------------------------------------------------------------------------------------------------------------------------------------------------------------------------------------------------------------------------------------------------------------------------------------------------------------------------------------------------------|
| <b>Step 1</b> | <b>enable</b><br><b>Example:</b><br><pre>Router&gt; enable</pre>                                                                                                                                                                                                                                                                                                                                                                                                                       | Enables privileged EXEC mode. <ul style="list-style-type: none"> <li>• Enter your password if prompted.</li> </ul>                                                                                                                                                                                                                                         |
| <b>Step 2</b> | <b>configure terminal</b><br><b>Example:</b><br><pre>Router# configure terminal</pre>                                                                                                                                                                                                                                                                                                                                                                                                  | Enters global configuration mode.                                                                                                                                                                                                                                                                                                                          |
| <b>Step 3</b> | <b>cable dsg client-list</b> <i>client-list-id</i> <b>id-index</b> <i>id</i><br><b>{application-id</b> <i>app-id</i>   <b>ca-system-id</b> <i>sys-id</i>   <b>mac-addr</b><br><i>mac-addr</i>   <b>broadcast</b> [ <i>broadcast-id</i> ]}<br><b>Example:</b><br><pre>Router(config)# cable dsg client-list 1 id-index<br/>1 mac-addr abcd.abcd.abcd</pre>                                                                                                                              | Sets the DSG client parameters. This command is changed from earlier Cisco IOS Releases, and for DSG 1.2, this command specifies the optional broadcast ID to client ID broadcast type and vendor specific parameter index.                                                                                                                                |
| <b>Step 4</b> | <b>cable dsg client-list</b> <i>client-list-id</i> <b>id-index</b> <i>id</i><br><b>[vendor-param</b> <i>vendor-group-id</i> ]<br><b>Example:</b><br><pre>Router(config-if)# cable dsg client-list 1 id-index<br/>1 vendor-param 1</pre>                                                                                                                                                                                                                                                | Sets vendor-specific parameters for the DSG client.                                                                                                                                                                                                                                                                                                        |
| <b>Step 5</b> | <b>cable dsg tunnel</b> <i>tunnel id</i> <b>mac_addr</b> <i>mac addr</i> <b>tg</b><br><i>tunnel-group</i> <b>clients</b> <i>client-list-id</i> [ <b>enable</b>   <b>disable</b> ]<br><b>Example:</b><br><pre>Router(config)# cable dsg tunnel mac-addr<br/>abcd.abcd.abcd tg 1 clients 1 enable</pre>                                                                                                                                                                                  | This command is changed to associate a tunnel group and client-list ID to a DSG tunnel. Also, an optional QoS service class name can be associated to the tunnel.<br><br><b>Note</b> To associate a cable service class with an A-DSG tunnel on a Cisco CMTS router, use the <code>cable dsg tunnel srv-class</code> command in global configuration mode. |
| <b>Step 6</b> | <b>cable dsg cfr</b> <i>cfr index</i> [ <b>dest-ip</b> { <i>ipaddr</i>   <i>hostname</i> }]<br><b>[tunnel</b> <i>tunnel-index</i> ] <b>[dest-port</b> <i>start end</i> ]] [ <b>priority</b><br><i>priority</i> ] <b>[src-ip</b> { <i>ipaddr</i>   <i>hostname</i> } <b>[src-prefix-len</b> <i>length</i><br>]] [ <b>enable</b>   <b>disable</b> ] [ <b>in-dcd</b> { <b>yes</b>   <b>no</b>   <b>ignore</b> }]<br><b>Example:</b><br><pre>Router(config)# cable dsg cfr 1 dest-ip</pre> | Specifies the DSG classifier index, with optional support for the DCD parameter, indicating whether or not to include the classifier in the DCD message.<br><br><b>Note</b> When you use the <b>ignore</b> option, the DSG classifier is not included in the DCD message.                                                                                  |

|               | Command or Action                                                                                               | Purpose                          |
|---------------|-----------------------------------------------------------------------------------------------------------------|----------------------------------|
|               | <code>224.225.225.225 tunnel 1 dest-port 40 50 priority 2 src-ip ciscovideo.com src-prefix-len 24 enable</code> |                                  |
| <b>Step 7</b> | <b>end</b><br><br><b>Example:</b><br><br><pre>Router(config)# end Router#</pre>                                 | Returns to privileged EXEC mode. |

**What to do next****Troubleshooting Tips**

Refer to **debug** and **show** commands in the [How to Monitor and Debug the Advanced-mode DOCSIS Set-Top Gateway Feature, on page 1317](#).

## Configuring Downstream DSG 1.2 Settings for Advanced-Mode DSG 1.2

When the global and client configurations are set for DSG 1.2 on the Cisco CMTS, use the following procedure to continue with DSG 1.2 downstream configurations.

**Procedure**

|               | Command or Action                                                                                                                                                                   | Purpose                                                                                                                      |
|---------------|-------------------------------------------------------------------------------------------------------------------------------------------------------------------------------------|------------------------------------------------------------------------------------------------------------------------------|
| <b>Step 1</b> | <b>enable</b><br><br><b>Example:</b><br><br><pre>Router&gt; enable</pre>                                                                                                            | Enables privileged EXEC mode. <ul style="list-style-type: none"> <li>• Enter your password if prompted.</li> </ul>           |
| <b>Step 2</b> | <b>configureterminal</b><br><br><b>Example:</b><br><br><pre>Router# configure terminal</pre>                                                                                        | Enters global configuration mode.                                                                                            |
| <b>Step 3</b> | <b>interface cable</b> <i>{slot /port  slot /subslot/port }</i><br><br><b>Example:</b><br><br><pre>Router(config)# interface cable 8/1/1</pre>                                      | Enters interface configuration mode.                                                                                         |
| <b>Step 4</b> | <b>cable downstream dsg tg</b> <i>group-id</i> [ <b>channel</b> <i>channel-id</i> ]<br><br><b>Example:</b><br><br><pre>Router(config-if)# cable downstream dsg tg 1 channel 1</pre> | Associates the DSG tunnel group to the downstream interface. To remove this setting, use the <b>no</b> form of this command. |

|               | Command or Action                                                                                                                                          | Purpose                                                                                                                                                                                                                               |
|---------------|------------------------------------------------------------------------------------------------------------------------------------------------------------|---------------------------------------------------------------------------------------------------------------------------------------------------------------------------------------------------------------------------------------|
| <b>Step 5</b> | <b>cable downstream dsg chan-list</b> <i>list-index</i><br><b>Example:</b><br><pre>Router(config-if)# cable downstream dsg chan-list 2</pre>               | Associates the A-DSG channel list entry to a downstream channel, to be included in the DCD message. To remove this setting, use the <b>no</b> form of this command.                                                                   |
| <b>Step 6</b> | <b>cable downstream dsg timer</b> <i>timer-index</i><br><b>Example:</b><br><pre>Router(config-if)# cable downstream dsg timer 3</pre>                      | Associates the DSG timer entry to a downstream channel, to be included in the DCD message. To remove this setting, use the no form of this command.                                                                                   |
| <b>Step 7</b> | <b>cable downstream dsg vendor-param</b> <i>vsif-grp-id</i><br><b>Example:</b><br><pre>Router(config-if)# cable downstream dsg vendor-param 2</pre>        | Associates A-DSG vendor parameters to a downstream to be included in the DCD message. To remove this configuration from the Cisco CMTS, use the no form of this command.                                                              |
| <b>Step 8</b> | <b>cable downstream dsg</b> [ <b>dcd-enable</b>   <b>dcd-disable</b> ]<br><b>Example:</b><br><pre>Router(config-if)# cable downstream dsg dcd-enable</pre> | Enables DCD messages to be sent on a downstream channel. This command is used when there are no enabled rules or tunnels for A-DSG currently on the Cisco CMTS. To disable DCD messages, use the <b>disable</b> form of this command. |
| <b>Step 9</b> | <b>end</b><br><b>Example:</b><br><pre>Router(config-if)# end</pre>                                                                                         | Returns to privileged EXEC mode.                                                                                                                                                                                                      |

## Configuring IP Multicast Operations

This section describes how to configure the operation of IP multicast transmissions on the cable and WAN interfaces on the Cisco CMTS. You should perform this configuration on each cable interface being used for DSG traffic and for each WAN interface that is connected to a network controller or Conditional Access (CA) server that is forwarding IP multicast traffic.

### Procedure

|               | Command or Action                                                                                 | Purpose                                  |
|---------------|---------------------------------------------------------------------------------------------------|------------------------------------------|
| <b>Step 1</b> | <b>configure terminal</b><br><b>Example:</b><br><pre>Router# configure terminal</pre>             | Enters global configuration mode.        |
| <b>Step 2</b> | <b>ip multicast-routing</b><br><b>Example:</b><br><pre>Router(config)# ip multicast-routing</pre> | Enables multicast routing on the router. |



|               | Command or Action                                                                                                                                                                                                                                                                                             | Purpose                                                                                                                                                                                                                                                                                                                                                                                                                                                                                                                                      |
|---------------|---------------------------------------------------------------------------------------------------------------------------------------------------------------------------------------------------------------------------------------------------------------------------------------------------------------|----------------------------------------------------------------------------------------------------------------------------------------------------------------------------------------------------------------------------------------------------------------------------------------------------------------------------------------------------------------------------------------------------------------------------------------------------------------------------------------------------------------------------------------------|
| <b>Step 3</b> | <b>ip pim ssm</b> {default   range{access-list   word }}<br><b>Example:</b><br><pre>Router(config)# ip pim ssm range 4</pre>                                                                                                                                                                                  | Defines the Source Specific Multicast (SSM) range of IP multicast addresses. To disable the SSM range, use the no form of this command.<br><br><b>Note</b> When an SSM range of IP multicast addresses is defined by the <b>ip pim ssm</b> command, no Multicast Source Discovery Protocol (MSDP) Source-Active (SA) messages will be accepted or originated in the SSM range.                                                                                                                                                               |
| <b>Step 4</b> | <b>ip cef distributed</b><br><b>Example:</b><br><pre>Router(config)# ip cef distributed</pre>                                                                                                                                                                                                                 | Enables Cisco Express Forwarding (CEF) on the route processor card. To disable CEF, use the no form of this command.<br><br>For additional information about the <b>ip cef</b> command, refer to the following document on Cisco.com: <ul style="list-style-type: none"> <li>• <i>Cisco IOS Switching Services Command Reference</i> , Release 12.3</li> </ul> <a href="http://www.cisco.com/en/US/docs/ios/12_3/switch/command/reference/switch_r.html">http://www.cisco.com/en/US/docs/ios/12_3/switch/command/reference/switch_r.html</a> |
| <b>Step 5</b> | <b>interface bundle</b> bundle-number<br><b>Example:</b><br><pre>Router(config)# interface bundle 10</pre>                                                                                                                                                                                                    | Enters interface configuration mode for each interface bundle being used for DSG traffic.                                                                                                                                                                                                                                                                                                                                                                                                                                                    |
| <b>Step 6</b> | <b>ip pim</b> {dense-mode   sparse-mode   sparse-dense-mode}<br><b>Example:</b><br><pre>Router(config-if)# ip pim dense-mode</pre>                                                                                                                                                                            | Enables Protocol Independent Multicast (PIM) on the cable interface, which is required to use the DSG feature:<br><br><b>Note</b> You must configure this command on each interface that forwards multicast traffic.                                                                                                                                                                                                                                                                                                                         |
| <b>Step 7</b> | Repeat <a href="#">Step 5, on page 1309</a> and <a href="#">Step 6, on page 1309</a> for each cable interface that is being used for DSG traffic. Also repeat these steps on each WAN interface that is forwarding IP multicast traffic from the DSG network controllers and Conditional Access (CA) servers. |                                                                                                                                                                                                                                                                                                                                                                                                                                                                                                                                              |
| <b>Step 8</b> | <b>end</b><br><b>Example:</b><br><pre>Router(config-if)# end</pre>                                                                                                                                                                                                                                            | Exits interface configuration mode and returns to privileged EXEC mode.                                                                                                                                                                                                                                                                                                                                                                                                                                                                      |

## Enabling DNS Query and DSG Name Process

The DSG name process enables the Cisco CMTS router to query the DNS server for faster classifier updates.

**Before you begin**

Ensure that the IP DNS-based hostname-to-address translation is configured on the Cisco CMTS router using the **ip domain-lookup** command in global configuration mode. This is configured by default, and the status is not displayed in the running configuration.

**Procedure**

|               | Command or Action                                                                                                                                                  | Purpose                                                                                     |
|---------------|--------------------------------------------------------------------------------------------------------------------------------------------------------------------|---------------------------------------------------------------------------------------------|
| <b>Step 1</b> | <b>configure terminal</b><br><b>Example:</b><br><br>Router# <code>configure terminal</code>                                                                        | Enters global configuration mode.                                                           |
| <b>Step 2</b> | <b>ip domain-name <i>name</i></b><br><b>Example:</b><br><br>Router(config)# <code>ip domain-name cisco.com</code>                                                  | Sets the IP domain name that the Cisco IOS software uses to complete unqualified host names |
| <b>Step 3</b> | <b>ip name-server <i>server-address</i> [<i>multiple-server-addresses</i>]</b><br><b>Example:</b><br><br>Router(config)# <code>ip name-server 131.108.1.111</code> | Sets the server IP address.                                                                 |
| <b>Step 4</b> | <b>cable dsg name-update-interval <i>minutes</i></b><br><b>Example:</b><br><br>Router(config)# <code>cable dsg name-update-interval 10</code>                      | Sets the interval to check the DNS server for any FQDN classifier changes.                  |
| <b>Step 5</b> | <b>end</b><br><b>Example:</b><br><br>Router(config)# <code>end</code>                                                                                              | Returns to privileged EXEC mode.                                                            |

## Configuring NAT to Support Unicast Messaging

This section describes how to configure a Cisco CMTS router for Network Address Translation (NAT) to enable the use of IP unicast addresses for DSG messaging. This allows the Cisco CMTS router to translate incoming IP unicast addresses into the appropriate IP multicast address for the DSG traffic.

For the Cisco cBR-8 router, A-DSG 1.2 can use an external router that is close to the Cisco CMTS to support unicast messaging. In this case, the nearby router must support NAT, and then send the address-translated multicast IP packets to the Cisco CMTS.



**Tip** This procedure should be performed after the cable interface has already been configured for DSG operations, as described in the [Configuration Examples for Advanced-Mode DSG, on page 1320](#).



**Note** The Cisco CMTS router supports NAT only when it is running an “IP Plus” (-i-) Cisco IOS software image. Refer to the release notes for your Cisco IOS release for complete image availability and requirements.

### Procedure

|               | Command or Action                                                                                                                                            | Purpose                                                                                                                                                                                                                                                                         |
|---------------|--------------------------------------------------------------------------------------------------------------------------------------------------------------|---------------------------------------------------------------------------------------------------------------------------------------------------------------------------------------------------------------------------------------------------------------------------------|
| <b>Step 1</b> | <b>configure terminal</b><br><b>Example:</b><br>Router# <b>configure terminal</b>                                                                            | Enters global configuration mode.                                                                                                                                                                                                                                               |
| <b>Step 2</b> | <b>interface</b> <i>wan-interface</i><br><b>Example:</b><br>Router(config)# <b>interface</b> FastEthernet0/0                                                 | Enters interface configuration mode for the specified WAN interface.                                                                                                                                                                                                            |
| <b>Step 3</b> | <b>ip nat outside</b><br><b>Example:</b><br>Router(config-if)# <b>ip nat outside</b>                                                                         | Configures the WAN interface as the “outside” (public) NAT interface.                                                                                                                                                                                                           |
| <b>Step 4</b> | <b>interface bundle</b> <i>bundle-number</i><br><b>Example:</b><br>Router(config-if)# <b>interface bundle</b> 10                                             | Enters interface configuration mode for the specified interface bundle.<br><br><b>Note</b> This interface bundle should have previously been configured for DSG operations.                                                                                                     |
| <b>Step 5</b> | <b>ip address</b> <i>ip-address mask secondary</i><br><b>Example:</b><br>Router(config-if)# <b>ip address</b> 192.168.18.1<br>255.255.255.0 <b>secondary</b> | Configures the cable interface with an IP address and subnet that should match the unicast address being used for DSG traffic. This IP address and its subnet must not be used by any other cable interfaces, cable modems, or any other types of traffic in the cable network. |
| <b>Step 6</b> | <b>ip nat inside</b><br><b>Example:</b><br>Router(config-if)# <b>ip nat inside</b>                                                                           | Configures the cable interface as the “inside” (private) NAT interface.                                                                                                                                                                                                         |
| <b>Step 7</b> | <b>exit</b><br><b>Example:</b><br>Router(config-if)# <b>exit</b>                                                                                             | Exits interface configuration mode and returns to global configuration mode.                                                                                                                                                                                                    |
| <b>Step 8</b> | <b>ip nat inside source static</b> <i>ip-multicast-address cable-ip-address</i><br><b>Example:</b>                                                           | Maps the unicast IP address assigned to the cable interface to the multicast address that should be used for the DSG traffic.                                                                                                                                                   |

|                | Command or Action                                                                                                                                       | Purpose                                                              |
|----------------|---------------------------------------------------------------------------------------------------------------------------------------------------------|----------------------------------------------------------------------|
|                | Router(config)# <b>ip nat inside source static 224.3.2.1 192.168.18.2</b>                                                                               |                                                                      |
| <b>Step 9</b>  | Repeat <a href="#">Step 2, on page 1311</a> and <a href="#">Step 8, on page 1311</a> for each cable interface to be configured for DSG unicast traffic. |                                                                      |
| <b>Step 10</b> | <b>end</b><br><b>Example:</b><br>Router(config)# <b>end</b>                                                                                             | Exits global configuration mode and returns to privileged EXEC mode. |

## Gatekeeper Cache Size

Use the **ip nat settings gatekeeper-size *number-of-entries*** command to modify the gatekeeper cache size. This command allows allocating a gatekeeper cache in the power of two based on the number of entries configured.

*number-of-entries* indicated the configurable number of entries that can be stored in gatekeeper cache. Each entry has the source and destination IP address of the packet.

When a device is sending both NAT mode and non-NAT mode traffic, increase gatekeeper cache size to skip nat processing for non-NAT mode traffic.

**Table 271: Supported Range for the Number of Entries Allowed for Gatekeeper**

| Cisco IOS XE Release                                                                                                                                                                                                        | Supported Range for the Number of Entries Allowed for Gatekeeper in the CLI                                                                                                                                     |
|-----------------------------------------------------------------------------------------------------------------------------------------------------------------------------------------------------------------------------|-----------------------------------------------------------------------------------------------------------------------------------------------------------------------------------------------------------------|
| Cisco IOS XE Dublin 17.12.1 and Cisco IOS XE Dublin 17.12.1w                                                                                                                                                                | 512-1000000<br><br><b>Note</b> Do not configure a value of more than 256000 for the Number of entries even if the CLI allows you to.<br><br>Configuring a value higher than 256000 may result in a CPP failure. |
| All other Cisco IOS XE releases, including <ul style="list-style-type: none"> <li>• Cisco IOS XE Releases before Cisco IOS XE Dublin 17.12.1</li> <li>• Cisco IOS XE Releases after Cisco IOS XE Dublin 17.12.1w</li> </ul> | 512-256000                                                                                                                                                                                                      |

### Examples

The following example shows how to enable the **ip nat settings gatekeeper-size *number-of-entries*** command on a cBR-8 router.

```
Router(config)#ip nat settings gatekeeper-size 1048576
Router(config)#end
```

## Configuring WAN Interfaces for Multicast Operations

In addition to basic WAN interface configuration on the Cisco CMTS, described in other documents, the following WAN interface commands should be configured on the Cisco CMTS to support IP multicast operations with A-DSG 1.2, as required.

- **ip pim**
- **ip pim ssm**
- **ip cef**

These commands are described in the [Configuring IP Multicast Operations, on page 1308](#), and in the following documents on Cisco.com.

For additional information about the **ip pim** command, refer to the following document on Cisco.com:

- *Cisco IOS IP Command Reference, Volume 3 of 4 : Multicast*, Release 12.3

[http://www.cisco.com/en/US/docs/ios/12\\_3/ipmulti/command/reference/iprnc\\_r.html](http://www.cisco.com/en/US/docs/ios/12_3/ipmulti/command/reference/iprnc_r.html)

For additional information about the **ip pim ssm** command, refer to the following document on Cisco.com:

- *Cisco IOS IP Command Reference, Volume 3 of 4: Multicast* , Release 12.3 T

[http://www.cisco.com/en/US/docs/ios/12\\_3t/ip\\_mcast/command/reference/ip3\\_i2gt.html](http://www.cisco.com/en/US/docs/ios/12_3t/ip_mcast/command/reference/ip3_i2gt.html)

For additional information about the **ip cef** command, refer to the following document on Cisco.com:

- *Cisco IOS Switching Services Command Reference* , Release 12.3

[http://www.cisco.com/en/US/docs/ios/12\\_3/switch/command/reference/swtch\\_r.html](http://www.cisco.com/en/US/docs/ios/12_3/switch/command/reference/swtch_r.html)

## Configuring a Standard IP Access List for Packet Filtering

This section describes how to configure a standard IP access list so that only authorized traffic is allowed on the cable interface.



**Tip** This procedure assumes a basic knowledge of how access lists use an IP address and bitmask to determine the range of IP addresses that are allowed access. For full details on configuring access lists, see the documents listed in the [Additional References, on page 1323](#).

### Procedure

|               | Command or Action                                                                                                                          | Purpose                                                                                                                                                      |
|---------------|--------------------------------------------------------------------------------------------------------------------------------------------|--------------------------------------------------------------------------------------------------------------------------------------------------------------|
| <b>Step 1</b> | <b>configure terminal</b><br><b>Example:</b><br>Router# <b>configure terminal</b>                                                          | Enters global configuration mode.                                                                                                                            |
| <b>Step 2</b> | <b>access-list access-list permit group-ip-address [mask]</b><br><b>Example:</b><br>Router(config)# <b>access-list 90 permit 228.1.1.1</b> | Creates an access list specifying that permits access to the specific multicast address that matches the specified <i>group-ip-address</i> and <i>mask</i> . |

|               | Command or Action                                                                                                                                                                              | Purpose                                                                                                                                                                                                                                                                                                                                                                                                                                                                                                                                                                                                                                                                 |
|---------------|------------------------------------------------------------------------------------------------------------------------------------------------------------------------------------------------|-------------------------------------------------------------------------------------------------------------------------------------------------------------------------------------------------------------------------------------------------------------------------------------------------------------------------------------------------------------------------------------------------------------------------------------------------------------------------------------------------------------------------------------------------------------------------------------------------------------------------------------------------------------------------|
|               |                                                                                                                                                                                                | <ul style="list-style-type: none"> <li>• <i>access-list</i> —Number or name of a standard IP access list. The number can range from 1 to 99 with no default.</li> <li>• <i>group-ip-address</i> —IP address to be used as a base for this access list. It should be based on the group IP address used for DSG tunnels of the interface.</li> <li>• <i>mask</i> —(Optional) Bitmask that determines which addresses in the <i>group-ip-address</i> will be allowed access. The default is 255.255.255.255.</li> </ul>                                                                                                                                                   |
| <b>Step 3</b> | <p><b>access-list</b> <i>access-list</i> <b>deny</b> <i>group-ip-address</i> [<i>mask</i> ]</p> <p><b>Example:</b></p> <pre>Router(config)# access-list 90 deny 224.0.0.0 15.255.255.255</pre> | <p>Configures the access list that denies access to any multicast address that matches the specified <i>group-ip-address</i> and <i>mask</i> .</p> <ul style="list-style-type: none"> <li>• <i>access-list</i> —Number or name of a standard IP access list. The number can range from 1 to 99 with no default.</li> <li>• <i>group-ip-address</i> —IP address to be used as a base for this access list. It should be based on the group IP address used for the interface's DSG tunnels.</li> <li>• <i>mask</i> —(Optional) Bitmask that determines which addresses in the <i>group-ip-address</i> will be allowed access. The default is 255.255.255.255.</li> </ul> |
| <b>Step 4</b> | <p><b>access-list</b> <i>access-list</i> <b>deny any</b></p> <p><b>Example:</b></p> <pre>Router(config)# access-list 90 deny any</pre>                                                         | <p>Configures the access list so that it denies access to any IP addresses other than the ones previously configured.</p>                                                                                                                                                                                                                                                                                                                                                                                                                                                                                                                                               |
| <b>Step 5</b> | <p><b>interface bundle</b> <i>bundle-number</i></p> <p><b>Example:</b></p> <pre>Router(config)# interface bundle 10</pre>                                                                      | <p>Enters interface configuration mode for the specified interface bundle.</p>                                                                                                                                                                                                                                                                                                                                                                                                                                                                                                                                                                                          |
| <b>Step 6</b> | <p><b>ip access-group</b> <i>access-list</i></p> <p><b>Example:</b></p> <pre>Router(config-if)# ip access-group 90</pre>                                                                       | <p>(Optional, but recommended) Configures the interface with the access list, so that packets are filtered by the list before being accepted on the interface.</p> <ul style="list-style-type: none"> <li>• <i>access-list</i> —Number or name of a standard IP access list. The number can range from 1 to 99 and should be the same list created in Step 3.</li> </ul> <p><b>Note</b> Standard Access lists only allow one address to be specified in the earlier step. If you apply an outbound access-list with only the multicast address of the tunnel denied, then the DSG traffic is not allowed to pass.</p>                                                   |

|               | Command or Action                                                          | Purpose                                                                                                                                                                                                                                                                                                                                                                                                                                                                                                  |
|---------------|----------------------------------------------------------------------------|----------------------------------------------------------------------------------------------------------------------------------------------------------------------------------------------------------------------------------------------------------------------------------------------------------------------------------------------------------------------------------------------------------------------------------------------------------------------------------------------------------|
|               |                                                                            | <p><b>Note</b> On the Cisco uBR10012 router, inbound access lists on the cable interface do not apply to multicast traffic, so they do not apply here. As a result, the Cisco uBR10012 requires that you use extended access lists that are blocked in the outbound direction for packets originating from the cable modem or CPE device on the network, and destined to the multicast group. The multicast group contains the classifiers associated with A-DSG 1.1 rules enabled on the interface.</p> |
| <b>Step 7</b> | <p><b>end</b></p> <p><b>Example:</b></p> <pre>Router(config-if)# end</pre> | Exits interface configuration mode and returns to Privileged EXEC mode.                                                                                                                                                                                                                                                                                                                                                                                                                                  |

## Configuring a Standard IP Access List for Multicast Group Filtering

This section describes how to configure a standard IP access list so that non-DOCSIS devices, such as DSG set-top boxes, can access only the authorized multicast group addresses and DSG tunnels.



**Tip** This procedure assumes a basic knowledge of how access lists use an IP address and bitmask to determine the range of IP addresses that are allowed access. For full details on configuring access lists, see the documents listed in the [Additional References, on page 1323](#).

### Procedure

|               | Command or Action                                                                                                                                                                   | Purpose                                                                                                                                                                                                                                                                                                                                                                                                                                                                                                            |
|---------------|-------------------------------------------------------------------------------------------------------------------------------------------------------------------------------------|--------------------------------------------------------------------------------------------------------------------------------------------------------------------------------------------------------------------------------------------------------------------------------------------------------------------------------------------------------------------------------------------------------------------------------------------------------------------------------------------------------------------|
| <b>Step 1</b> | <p><b>configure terminal</b></p> <p><b>Example:</b></p> <pre>Router# configure terminal</pre>                                                                                       | Enters global configuration mode.                                                                                                                                                                                                                                                                                                                                                                                                                                                                                  |
| <b>Step 2</b> | <p><b>access-list</b> <i>access-list</i> <b>permit</b> <i>group-ip-address</i> [<i>mask</i> ]</p> <p><b>Example:</b></p> <pre>Router(config)# access-list 90 permit 228.1.1.1</pre> | <p>Creates an access list specifying that permits access to the specific multicast address that matches the specified <i>group-ip-address</i> and <i>mask</i> .</p> <ul style="list-style-type: none"> <li><i>access-list</i> —Number or name of a standard IP access list. The number can range from 1 to 99 with no default.</li> <li><i>group-ip-address</i> —IP address to be used as a base for this access list. It should be based on the group IP address used for the interface's DSG tunnels.</li> </ul> |

|               | Command or Action                                                                                                                                                                              | Purpose                                                                                                                                                                                                                                                                                                                                                                                                                                                                                                                                                                                                                                                           |
|---------------|------------------------------------------------------------------------------------------------------------------------------------------------------------------------------------------------|-------------------------------------------------------------------------------------------------------------------------------------------------------------------------------------------------------------------------------------------------------------------------------------------------------------------------------------------------------------------------------------------------------------------------------------------------------------------------------------------------------------------------------------------------------------------------------------------------------------------------------------------------------------------|
|               |                                                                                                                                                                                                | <ul style="list-style-type: none"> <li><i>mask</i> —(Optional) Bitmask that determines which addresses in the <i>group-ip-address</i> will be allowed access. The default is 255.255.255.255.</li> </ul>                                                                                                                                                                                                                                                                                                                                                                                                                                                          |
| <b>Step 3</b> | <p><b>access-list</b> <i>access-list</i> <b>deny</b> <i>group-ip-address</i> [<i>mask</i> ]</p> <p><b>Example:</b></p> <pre>Router(config)# access-list 90 deny 224.0.0.0 15.255.255.255</pre> | <p>Configures the access list that denies access to any multicast address that matches the specified <i>group-ip-address</i> and <i>mask</i> .</p> <ul style="list-style-type: none"> <li><i>access-list</i> —Number or name of a standard IP access list. The number can range from 1 to 99 with no default.</li> <li><i>group-ip-address</i> —IP address to be used as a base for this access list. It should be based on the group IP address used for the interface's DSG tunnels.</li> <li><i>mask</i> —(Optional) Bitmask that determines which addresses in the <i>group-ip-address</i> will be allowed access. The default is 255.255.255.255.</li> </ul> |
| <b>Step 4</b> | <p><b>access-list</b> <i>access-list</i> <b>deny</b> <b>any</b></p> <p><b>Example:</b></p> <pre>Router(config)# access-list 90 deny any</pre>                                                  | <p>Configures the access list so that it denies access to any IP addresses other than the ones previously configured.</p>                                                                                                                                                                                                                                                                                                                                                                                                                                                                                                                                         |
| <b>Step 5</b> | <p><b>interface</b> <b>cable</b> <i>interface</i></p> <p><b>Example:</b></p> <pre>Router(config)# interface cable 3/0</pre>                                                                    | <p>Enters interface configuration mode for the specified cable interface.</p>                                                                                                                                                                                                                                                                                                                                                                                                                                                                                                                                                                                     |
| <b>Step 6</b> | <p><b>ip igmp access-group</b> <i>access-list</i> [<i>version</i> ]</p> <p><b>Example:</b></p> <pre>Router(config-if)# ip igmp access-group 90</pre>                                           | <p>(Optional, but recommended) Configures the interface to accept traffic only from the associated access list, so that only authorized devices are allowed to access the DSG tunnels.</p> <ul style="list-style-type: none"> <li><i>access-list</i> —Number or name of a standard IP access list. The number can range from 1 to 99 and should be the same list created in Step 3.</li> <li><i>version</i> —(Optional) Specifies the IGMP version. The default is 2.</li> </ul>                                                                                                                                                                                  |
| <b>Step 7</b> | <p><b>end</b></p> <p><b>Example:</b></p> <pre>Router(config-if)# end</pre>                                                                                                                     | <p>Exits interface configuration mode and returns to privileged EXEC mode.</p>                                                                                                                                                                                                                                                                                                                                                                                                                                                                                                                                                                                    |



## Disabling A-DSG Forwarding on the Primary Channel

You can disable A-DSG forwarding per primary capable interface.

### Procedure

|        | Command or Action                                                                                                                                    | Purpose                                                                                                                                                                                            |
|--------|------------------------------------------------------------------------------------------------------------------------------------------------------|----------------------------------------------------------------------------------------------------------------------------------------------------------------------------------------------------|
| Step 1 | <b>configure terminal</b><br><b>Example:</b><br>Router# <b>configure terminal</b>                                                                    | Enters global configuration mode.                                                                                                                                                                  |
| Step 2 | <b>interface modular-cable slot /subslot/port<br/>:interface-number</b><br><b>Example:</b><br>Router(config)# <b>interface modular-cable 1/0/0:0</b> | Specifies the modular cable interface and enters cable interface configuration mode. Variables for this command may vary depending on the Cisco CMTS router and the Cisco IOS-XE software release. |
| Step 3 | <b>cable downstream dsg disable</b><br><b>Example:</b><br>Router(config-if)# <b>cable downstream dsg disable</b>                                     | Disables A-DSG forwarding and DCD messages on the primary capable interface.                                                                                                                       |
| Step 4 | <b>end</b><br><b>Example:</b><br>Router(config-if)# <b>end</b>                                                                                       | Returns to privileged EXEC mode.                                                                                                                                                                   |

## How to Monitor and Debug the Advanced-mode DOCSIS Set-Top Gateway Feature

This section describes the following commands that you can use to monitor and display information about the Advanced-mode DOCSIS Set-Top Gateway feature:

### Displaying Global Configurations for Advanced-Mode DSG 1.2

The following commands display globally-configured or interface-level DSG settings, status, statistics, and multiple types of DSG 1.2 tunnel information.

#### show cable dsg cfr

To verify all DSG classifier details, such as the classifier state, source, and destination IP addresses, use the **show cable dsg cfr** command.

To verify details of a particular DSG classifier, use the **show cable dsg cfr cfr-id** command.

To verify the detailed output for all DSG classifiers, use the **show cable dsg cfr verbose** command.

To verify the detailed output for a single DSG classifier, use the **show cable dsg cfr *cfr-id* verbose** command.

### show cable dsg host

To verify the mapping of the DSG hostnames and IP addresses on a Cisco CMTS router, use the **show cable dsg host** command.

To verify the verbose output of the mapping of the DSG hostnames and IP addresses on a Cisco CMTS router, use the **show cable dsg host verbose** command.

### show cable dsg tunnel

To display tunnel MAC address, state, tunnel group id, classifiers associated to tunnel and its state, use the **show cable dsg tunnel** command in privileged EXEC mode. This command also displays the number of interfaces to which a tunnel is associated, the clients associated, and the QoS service class name for all the configured tunnels.

To display information for a given DSG tunnel, use the **show cable dsg tunnel *tunnel-id*** command, specifying the tunnel for which to display information.

**show cable dsg tunnel *tunnel-id* [cfr | clients | interfaces | statistics | verbose]**

- **cfr**—Shows DSG tunnel classifiers.
- **clients**—Shows DSG tunnel clients.
- **interfaces**—Shows DSG tunnel interfaces.
- **statistics**—Shows DSG tunnel statistics.
- **verbose**—Shows DSG tunnel detail information.

### show cable dsg tg

To display the configured parameters for all DSG tunnel groups, use **show cable dsg tg** command.



---

**Note** The **Chan state** column in the **show cable dsg tg** command output indicates that a channel belonging to a tunnel group is either enabled or disabled. It is possible that a tunnel group is enabled but a particular channel in that tunnel group is disabled.

---

To display the configured parameters for the specified tunnel group, use **show cable dsg tg *tg-id* channel *channel-id*** command.

To display detailed information for the specified tunnel group, use **show cable dsg tg *tg-id* channel *channel-id* verbose** command.

### show running-config interface

To display a tunnel group attached to a subinterface, use the **show running-config interface** command in privileged EXEC mode, as shown in the example below:

```
Router# show running-config interface bundle 11.2
!
interface Bundle11.2
 ip address 4.4.2.1 255.255.255.0
 no ip unreachable
 ip pim sparse-mode
```

```
ip igmp static-group 230.1.1.30
no cable ip-multicast-echo
cable dsg tg 61
end
```



**Note** The IGMP static group IP address created automatically at the time of DSG configuration is not displayed in the **show running-config interface** command output.

### show cable dsg static-group bundle

To verify all DSG static groups configured under a bundle interface, use the **show cable dsg static-group bundle** command in privileged EXEC mode.

## Displaying Interface-level Configurations for Advanced-Mode DSG 1.2

The following **show** commands display interface-level configurations for A-DSG 1.2.

### show cable dsg tunnel interfaces

To display all interfaces and DSG rules for the associated tunnel, use the **show cable dsg tunnel interfaces** command in privileged EXEC mode.

**show cable dsg tunnel** (*tunnel-id*) **interfaces**

### show interfaces cable dsg downstream

To display DSG downstream interface configuration information, to include the number of DSG tunnels, classifiers, clients, and vendor-specific parameters, use the **show interfaces cable dsg downstream** command in privileged EXEC mode.

### show interfaces cable dsg downstream dcd

To display DCD statistics for the given downstream, use the **show interfaces cable dsg downstream dcd** command in privileged EXEC mode. This command only displays DCD Type/Length/Value information if the **debug cable dsg** command is previously enabled.

### show interfaces cable dsg downstream tg

To display DSG tunnel group parameters, and rule information applying to the tunnel group, to include tunnels and tunnel states, classifiers, and client information, use the **show interfaces cable dsg downstream tg** command in privileged EXEC mode. You can display information for a specific tunnel, if specified.

### show interfaces cable dsg downstream tunnel

To display DSG tunnel information associated with the downstream, use the **show interfaces cable dsg downstream tunnel** command in privileged EXEC mode.

## Debugging Advanced-Mode DSG

To enable debugging for A-DSG on a Cisco CMTS router, use the debug cable dsg command in privileged EXEC mode.

## Configuration Examples for Advanced-Mode DSG

This configuration example illustrates a sample DSG network featuring these components:

- Two Cisco universal broadband routers
- IP Multicast for each DSG implementation
- Two DSG Clients for each Cisco CMTS
- Two DSG Servers (one for each Cisco CMTS)

Each Cisco CMTS is configured as follows, and the remainder of this topic describes example configurations that apply to this architecture.

### CMTS Headend 1

- DSG Server #1—Connected to Cisco CMTS via IP Multicast, with DSG Server having IP Address 12.8.8.1
- Destination IP Address for the Cisco CMTS—228.9.9.1
- DSG Tunnel Address—0105.0005.0005
- Downstream #1 Supporting two DSG Clients:
  - DSG Client #1—ID 101.1.1
  - DSG Client #2—ID 102.2.2

### CMTS Headend 2

- DSG Server #2—Connected to Cisco CMTS via IP Multicast, with DSG Server having IP Address 12.8.8.2
- Destination IP Address for the Cisco CMTS—228.9.9.2
- DSG Tunnel Address—0106.0006.0006
- Downstream #2 Supporting two DSG Clients:
  - DSG Client #1—ID 101.1.1
  - DSG Client #2—ID 102.2.2

### Example of Two DSG Tunnels with MAC DA Substitution

In this configuration, and given the two Cisco CMTS Headends cited above, below are the two sets of DSG rules, with each set applying to each Cisco CMTS, in respective fashion.

These settings apply to DSG #1 and two downstreams:

- DSG Rule ID 1
- DSG Client ID 101.1.1
- DSG Tunnel Address 105.5.5

These settings apply to DSG Rule #2 and two downstreams:

- DSG Rule ID 1
- DSG Client ID 102.2.2
- DSG Tunnel Address 106.6.6

### DSG Example with Regionalization Per Downstream

In this configuration, and given the two Cisco CMTS Headends cited earlier in this topic, below are two downstream rules that can be configured in this architecture, for example:

- Downstream Rule #1
  - DSG Rule ID #1
  - DSG Client ID—101.1.1
  - DSG Tunnel Address—105.5.5
- Downstream Rule #2
  - DSG Rule ID #2
  - DSG Client ID—102.2.2
  - DSG Tunnel Address—106.6.6

### DSG Example with Regionalization Per Upstream

In this configuration, and given the two Cisco CMTS Headends cited earlier in this topic, below are two upstream rules that can be configured in this architecture, for example:

- Upstream Rule #1
  - DSG Rule ID #1
  - DSG Client ID—101.1.1
  - DSG UCID Range—0 to 2
  - DSG Tunnel Address—105.5.5
- Upstream Rule #2
  - DSG Rule ID #2
  - DSG Client ID—102.2.2
  - DSG UCID Range—3 to 5
  - DSG Tunnel Address—106.6.6

### Example of Two DSG Tunnels with Full Classifiers and MAC DA Substitution

In this configuration, and given the two Cisco CMTS Headends cited above, below are the two sets of DSG rules, with each set applying to each Cisco CMTS, in respective fashion.

These settings apply to DSG #1:

- DSG Rule ID 1
- Downstreams 1 and 2
- DSG Client ID 101.1.1
- DSG Tunnel Address 105.5.5
- DSG Classifier ID—10
- IP SA—12.8.8.1
- IP DA—228.9.9.1

- UDP DP—8000

These settings apply to DSG Rule #2:

- DSG Rule ID 2
- Downstreams 1 and 2
- DSG Client ID 102.2.2
- DSG Tunnel Address 106.6.6
- DSG Classifier ID—20
- IP SA—12.8.8.2
- IP DA—228.9.9.2
- UDP DP—8000

### Example of One DSG Tunnel Supporting IP Multicast from Multiple DSG Servers

In this configuration, and given the two Cisco CMTS Headends cited earlier in this topic, below is an example of one DSG Tunnel with multiple DSG servers supporting IP Multicast:

- DSG Rule ID 1
- Downstreams 1 and 2
- DSG Client ID 101.1.1 and 102.2.2
- DSG Tunnel Address 105.5.5
- DSG Classifier ID—10
  - IP SA—12.8.8.1
  - IP DA—228.9.9.1
  - UDP DP—8000
- DSG Classifier ID—20
  - IP SA—12.8.8.2
  - IP DA—228.9.9.2
  - UDP DP—8000

## Example: Enabling DNS Query

The following example shows how to enable a DNS query on the Cisco CMTS router:

```
Router# configure terminal
Router(config)# ip domain-lookup
Router(config)# ip domain-name cisco.com
Router(config)# ip name-server 131.108.1.111
Router(config)# cable dsg name-update-interval 10
Router(config)# end
```

## Example: Disabling A-DSG Forwarding on the Primary Channel

The following example shows how to disable A-DSG forwarding on a primary capable modular interface on the Cisco CMTS router:

```
Router# configure terminal
Router(config)# interface modular-cable 1/0/0:0
```

```
Router(config-if)# cable downstream dsg disable
Router(config-if)# end
```

## Additional References

The following sections provide references related to A-DSG 1.2.

### Technical Assistance

| Description                                                                                                                                                                                                                                                                                                                                                                           | Link                                                                                                              |
|---------------------------------------------------------------------------------------------------------------------------------------------------------------------------------------------------------------------------------------------------------------------------------------------------------------------------------------------------------------------------------------|-------------------------------------------------------------------------------------------------------------------|
| The Cisco Support and Documentation website provides online resources to download documentation, software, and tools. Use these resources to install and configure the software and to troubleshoot and resolve technical issues with Cisco products and technologies. Access to most tools on the Cisco Support and Documentation website requires a Cisco.com user ID and password. | <a href="http://www.cisco.com/cisco/web/support/index.html">http://www.cisco.com/cisco/web/support/index.html</a> |

## Feature Information for Advanced-Mode DSG 1.2 for the Cisco CMTS Routers

Use Cisco Feature Navigator to find information about the platform support and software image support. Cisco Feature Navigator enables you to determine which software images support a specific software release, feature set, or platform. To access Cisco Feature Navigator, go to the <https://cfng.cisco.com/> link. An account on the Cisco.com page is not required.



**Note** The following table lists the software release in which a given feature is introduced. Unless noted otherwise, subsequent releases of that software release train also support that feature.

**Table 272: Feature Information for DOCSIS Set-Top Gateway and A-DSG for the Cisco CMTS Routers**

| Feature Name                                      | Releases                    | Feature Information                                                                                               |
|---------------------------------------------------|-----------------------------|-------------------------------------------------------------------------------------------------------------------|
| DOCSIS Set-Top Gateway for the Cisco CMTS Routers | Cisco IOS XE Everest 16.6.1 | This feature was integrated into Cisco IOS XE Everest 16.6.1 on the Cisco cBR Series Converged Broadband Routers. |







## CHAPTER 85

# Cisco Network Registrar for the Cisco CMTS Routers

This chapter supplements the Cisco Network Registrar (CNR) documentation by providing additional cable-specific instructions to provision a hybrid fiber-coaxial (HFC) network using Cisco universal broadband routers as CMTSs at the headend of the network.



**Note** For information about the IPv6 provisioning on CNR server, please refer to [IPv6 on Cable](#).

Your software release may not support all the features that are documented in this module. For the latest feature information and caveats, see the release notes for your platform and software release. The Feature Information Table at the end of this document provides information about the documented features and lists the releases in which each feature is supported.

Use Cisco Feature Navigator to find information about platform support and Cisco software image support. To access Cisco Feature Navigator, go to <http://tools.cisco.com/ITDIT/CFN/>. An account on <http://www.cisco.com/> is not required.

### Contents

- [Hardware Compatibility Matrix for the Cisco cBR Series Routers](#), on page 1326
- [Servers Required on the HFC Network](#), on page 1327
- [Cisco Network Registrar Description](#), on page 1328
- [Overview of DHCP Using CNR](#), on page 1328
- [How Cisco Converged Broadband Routers and Cable Modems Work](#), on page 1329
- [DHCP Fields and Options for Cable Modems](#), on page 1330
- [Cisco Network Registrar Sample Configuration](#), on page 1331
- [Overview of Scripts](#), on page 1334
- [Placement of Scripts](#), on page 1335
- [Activating Scripts in Cisco Network Registrar](#), on page 1335
- [Configuring the Cisco CMTS Routers to Use Scripts](#), on page 1335
- [Configuring the System Default Policy](#), on page 1336
- [Creating Selection Tag Scopes](#), on page 1336
- [Creating Network Scopes](#), on page 1337
- [Creating Policies for Class of Service or for Upgrading Cable Modem Cisco IOS Images](#), on page 1338

- [CNR Steps to Support Subinterfaces, on page 1338](#)
- [Additional References, on page 1339](#)

## Hardware Compatibility Matrix for the Cisco cBR Series Routers



**Note** The hardware components that are introduced in a given Cisco IOS-XE Release are supported in all subsequent releases unless otherwise specified.

*Table 273: Hardware Compatibility Matrix for the Cisco cBR Series Routers*

| Cisco CMTS Platform                    | Processor Engine                                                                                                                                                                                  | Interface Cards                                                                                                                                                                                                                                                                                                                                                                                                                                                                                                                                                                                                                                                                                                                                                                                 |
|----------------------------------------|---------------------------------------------------------------------------------------------------------------------------------------------------------------------------------------------------|-------------------------------------------------------------------------------------------------------------------------------------------------------------------------------------------------------------------------------------------------------------------------------------------------------------------------------------------------------------------------------------------------------------------------------------------------------------------------------------------------------------------------------------------------------------------------------------------------------------------------------------------------------------------------------------------------------------------------------------------------------------------------------------------------|
| Cisco cBR-8 Converged Broadband Router | <p><b>Cisco IOS-XE Release 16.5.1 and Later Releases</b></p> <p>Cisco cBR-8 Supervisor:</p> <ul style="list-style-type: none"> <li>• PID—CBR-SUP-250G</li> <li>• PID—CBR-CCAP-SUP-160G</li> </ul> | <p><b>Cisco IOS-XE Release 16.5.1 and Later Releases</b></p> <p>Cisco cBR-8 CCAP Line Cards:</p> <ul style="list-style-type: none"> <li>• PID—CBR-LC-8D30-16U30</li> <li>• PID—CBR-LC-8D31-16U30</li> <li>• PID—CBR-RF-PIC</li> <li>• PID—CBR-RF-PROT-PIC</li> <li>• PID—CBR-CCAP-LC-40G</li> <li>• PID—CBR-CCAP-LC-40G-R</li> <li>• PID—CBR-CCAP-LC-G2-R</li> <li>• PID—CBR-SUP-8X10G-PIC</li> <li>• PID—CBR-2X100G-PIC</li> </ul> <p>Digital PICs:</p> <ul style="list-style-type: none"> <li>• PID—CBR-DPIC-8X10G</li> <li>• PID—CBR-DPIC-2X100G</li> </ul> <p>Cisco cBR-8 Downstream PHY Module:</p> <ul style="list-style-type: none"> <li>• PID—CBR-D31-DS-MOD</li> </ul> <p>Cisco cBR-8 Upstream PHY Modules:</p> <ul style="list-style-type: none"> <li>• PID—CBR-D31-US-MOD</li> </ul> |



**Note** Do not use DPICs (8X10G and 2x100G) to forward IP traffic, as it may cause buffer exhaustion, leading to line card reload.

The only allowed traffic on a DPIC interface is DEPI, UEPI, and GCP traffic from the Cisco cBR-8 router to Remote PHY devices. Other traffic such as DHCP, SSH, and UTSC should flow via another router, since DPICs cannot be used for normal routing.

## Servers Required on the HFC Network

A TFTP server, DHCP server, and time-of-day (TOD) server are required to support two-way data cable modems on an HFC network. A cable modem will not boot if these servers are not available. The log server and security servers are not required to configure and operate a cable modem. If the log server or security servers are not present, a cable modem will generate warning messages, but it will continue to boot and function properly.

**Figure 34: Servers Required on a Two-Way HFC Network**

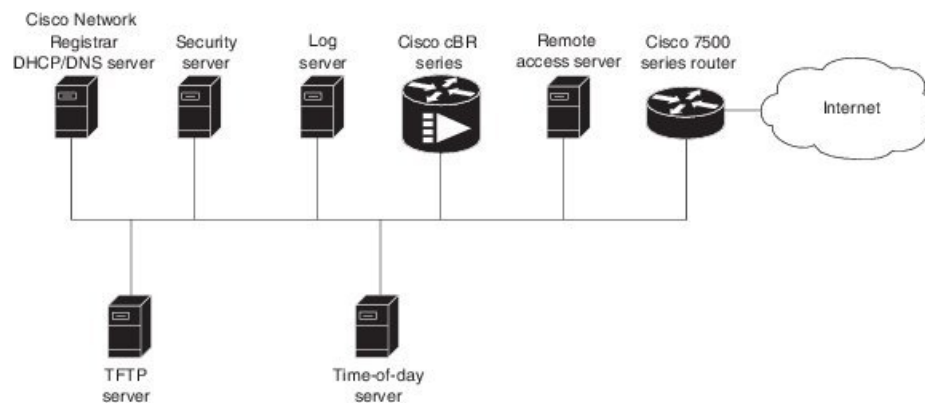

The servers shown here can exist on the same platform. For example, the time-of-day server and the TFTP server can run on the same platform.

364-545

In this provisioning model, TOD and TFTP servers are standard Internet implementations of the RFC 868 and RFC 1350 specifications. Most computers running a UNIX-based operating system supply TOD and TFTP servers as a standard software feature. Typically, the TOD server is embedded in the UNIX *inetd* and it requires no additional configuration. The TFTP server is usually disabled in the standard software but can be enabled by the user. Microsoft NT server software includes a TFTP server that can be enabled with the services control panel. Microsoft NT does not include a TOD server. A public domain version of the TOD server for Microsoft NT can be downloaded from several sites.

The DHCP and Domain Name System (DNS) server shown in Figure above must be the DHCP/DNS server available in Cisco Network Registrar version 2.0 or later. CNR is the only DHCP server that implements policy-based assignment of IP addresses. The headend must be a Cisco cBR-8 converged broadband router. The remote access server is only required on HFC networks that are limited to one-way (downstream only) communication. In a one-way HFC network, upstream data from a PC through the headend to the Internet is carried over a dialup connection. This dialup connection for upstream data is referred to as telco return. For simplification, the model will not include a log or security server. Cable modems can be set up to use the

logging and security servers by including the appropriate DHCP options in the cable modem policy as described in the *Cisco Network Registrar User Manual*.

## Cisco Network Registrar Description

CNR is a dynamic IP address management system, running on Windows or Solaris, that uses the Dynamic Host Configuration Protocol (DHCP) to assign IP addresses to cable interfaces, PCs, and other devices on the broadband network. The CNR tool includes script extensions that allow a cable system administrator to define and view individual DHCP options, define the identity or type of device on the network, and assign the device to a predefined class or group.

Using the CNR tool, a cable system administrator can specify policies to provide:

- Integrated DHCP and Domain Name Server (DNS) services
- Time of Day (ToD) and Trivial File Transfer Protocol (TFTP) server based on the size of the network
- DHCP safe failover and dynamic DNS updates



---

**Note** This is available only in CNR 3.0 or higher.

---

Using the CNR tool and the extension scripts identified in the [Overview of Scripts, on page 1334](#) section, a cable system administrator can specify scopes, policies, and options for the network and each cable interface based on the services and configuration to support at each subscriber site.



---

**Note** Scopes refer to the administrative grouping of TCP/IP addresses; all IP addresses within a scope should be on the same subnet.

---

The cable system administrator defines system default policies for all standard options and uses scope-specific policies for options related to particular subnets, such as cable interfaces. This allows DHCP to send the information with the IP address.

Seven entry points exist for scripts:

- post-packet-decode
- pre-client-lookup
- post-client-lookup—Examines and takes action on results of the client-class process, places data items in the environment dictionary to use at the pre-packet-encode extension point, includes DHCP relay option
- check-lease-acceptable
- pre-packet-encode
- post-sent-packet
- pre-dns-add-forward

## Overview of DHCP Using CNR

Cisco Network Registrar (CNR) is a dynamic IP address management system that uses the Dynamic Host Configuration Protocol (DHCP) and assigns IP addresses to PCs and other devices on a network based on a

predefined set of policies, such as class of service. CNR assigns available IP addresses from address pools based on the identity or type of the requesting device and the policies in effect. For example, CNR can distinguish between registered devices, unregistered devices, and registered devices that have been assigned to a particular class of service.

CNR also provides extensions that can be customized (via programming or a script) so that you can view individual DHCP options, determine the identity or type of a device based on the content of the options, and assign a device to a predefined class or group. Using these extensions, you can determine the difference between PCs and cable modems and assign them IP addresses from different address pools.

In typical data-over-cable environments, service providers are interested in simplifying provisioning to limit the amount of information that must be collected about subscribers' customer premise equipment (CPEs). To support current provisioning models, a field technician must be sent to a subscriber's home or business to install and setup a cable modem. During this site visit, the technician might register the serial number and MAC address of the cable modem in the customer account database. Because a field technician must go to a subscriber's site to replace a cable modem, you can easily track modem information.

Manually registering and tracking information about a cable subscriber's PC is more difficult. A subscriber might purchase a new PC or exchange the network interface card (NIC) without notifying you of the change. Automatic provisioning with CNR reduces the amount of customer service involvement needed to track customer equipment. To use the provisioning model described in this document, you must still track serial numbers and MAC addresses for cable modems, but you do not need to track information about the PC or NIC cards installed at a subscriber site.

The remainder of this document describes how to configure CNR to support this model. The following sections describe the equipment and servers required for the cable headend, provide an overview of the interaction between DOCSIS-compatible cable modems and the Cisco universal broadband routers, and provide a guide on how to configure CNR to support this provisioning model.

## How Cisco Converged Broadband Routers and Cable Modems Work

Cisco converged broadband routers and cable modems are based on the Data Over Cable Service Interface Specification (DOCSIS) standards. These standards were created by a consortium of cable service providers called Multimedia Cable Network Systems, Ltd. (MCNS) to that cable headend and cable modem equipment produced by different vendors will interoperate. The key DOCSIS standards provide the basis for a cable modem to communicate with any headend equipment and headend equipment to communicate with any cable modem.

Cable modems are assigned to operate on specific cable channels so activity can be balanced across several channels. Each Cisco cBR-8 router installed at the headend serves a specific channel. Part of network planning is to decide which channel each cable modem can use.

A cable modem cannot connect to the network until the following events occur:

- The cable modem initializes and ranges through available frequencies until it finds the first frequency that it can use to communicate to the headend. The cable modem might be another vendor's DOCSIS-compatible device and the headend might have a Cisco cBR-8 router installed. At this point on the initial connection, the cable modem cannot determine if it is communicating on the correct channel.
- The cable modem goes through the DHCP server process and receives a configuration file from the server.
- One of the parameters in the configuration file tells the cable modem which channel it can use.

- If the assigned channel is not available on the Cisco cBR-8 router to which the cable modem is currently connected, it resets itself and comes up on the assigned channel.
- During this second DHCP process, the modem will be connected to the correct CMTS. This time, the configuration file will be loaded. For a DOCSIS-compatible cable modem to access the network, it might go through the DHCP server two times on two different networks; therefore, one-lease-per-client IP addressing is critical.

## DHCP Fields and Options for Cable Modems

DHCP options and packet fields are required to enable cable modems to boot and operate properly. Table below lists the required DHCP options and fields.

*Table 274: Required DHCP Fields and Options*

| Required Field/Option | Field/Option In Cisco Network Registrar | Value/Description                                                                                                                                                                                                                              |
|-----------------------|-----------------------------------------|------------------------------------------------------------------------------------------------------------------------------------------------------------------------------------------------------------------------------------------------|
| <b>Fields</b>         |                                         |                                                                                                                                                                                                                                                |
| giaddr                | -                                       | IP address. As a DHCP packet passes through the relay agent to the DHCP server, the relay agent supplies a unique IP address to the packet and stores it in this field. The relay agent is a cBR-8 router with the iphelper attribute defined. |
| subnet-mask           | -                                       | Subnet mask for the IP address stored in the giaddr field. This value is also stored in the DHCP packet by the relay agent.                                                                                                                    |
| file                  | Packet-file-name                        | Name of the cable modem configuration file that will be read from a TFTP server.                                                                                                                                                               |
| siaddr                | Packet-siaddr                           | IP address of the TFTP server where configuration files are stored.                                                                                                                                                                            |
| <b>Options</b>        |                                         |                                                                                                                                                                                                                                                |
| Time-servers          | -                                       | List of hosts running the time server specified in the RFC 868 standard.                                                                                                                                                                       |
| Time-offset           | -                                       | Time offset of a cable modem internal clock from Universal Time Coordinated (UTC). This value is used by cable modems to calculate the local time that is stored in time-stamping error logs.                                                  |

| Required Field/Option | Field/Option In Cisco Network Registrar | Value/Description                                                                                        |
|-----------------------|-----------------------------------------|----------------------------------------------------------------------------------------------------------|
| MCNS-security-server  | -                                       | IP address of the security server. This should be set if security is required. See RFC 1533 for details. |

## Cisco Network Registrar Sample Configuration

You can use the following information to set up Cisco Network Registrar in a trial configuration. The configuration describes DHCP-related setup only; it does not cover setting up DNS or configuring dynamic DNS (DDNS). You should be familiar with important CNR concepts including scopes, primary and secondary scopes, scope selection tags, client classes, and CNR policies. See the Using Network Registrar publication for detailed information on these concepts.

In the trial configuration, you can configure CNR to perform the following operations:

- Receive DHCP requests from a cable modem and a PC on an HFC network via a port supporting multiple network numbers. The Cisco cBR-8 router at the headend must be configured as a forwarder (iphelper is configured).
- Serve IP addresses on two networks; a net-10 network (non-Internet routable) and a net-24 network (Internet routable).
- Tell the difference between a cable modem and a PC based on the MAC address of the device and provide net-24 addresses to the PC and net-10 addresses to the cable modem.
- Refuse to serve IP addresses to MAC addresses that it does not recognize.

To perform these options, you must implement the following CNR configuration items:

- Create two scope selection tags; one for PCs, one for cable modems.
- Create two client-classes; one for PCs, one for cable modems.
- Create a lease policy appropriate for the cable modem devices.
- Create a lease policy appropriate for the PC devices.
- Create a scope containing Class A net-24 (routable) addresses.
- Create a scope containing Class A net-10 (nonroutable) addresses.
- Identify the scope containing the net-24 addresses as the primary scope and configure the other scope containing the net-10 addresses as secondary to the net-24 scope.



**Note** The Cisco cBR-8 router upstream ports must be configured with the primary network address on the net-24 network; such as 24.1.1.1.

- Assign the policies to the appropriate scope.
- Add the MAC address of the cable modem and the PC to the client-entry list.
- Associate the PC tag with the scope containing routable addresses.
- Associate the cable modem tag with the scope containing nonroutable addresses.
- Associate the cable modem tag with the cable modem client-class.
- Associate the PC tag with the PC client-class.
- Assign the PC MAC to the PC class.

- Assign the cable modem MAC to the cable modem class.
- Enable client-class processing.

Figure below shows the trial CNR configuration in an HFC network.

**Figure 35: Trial Configuration in an HFC Network**

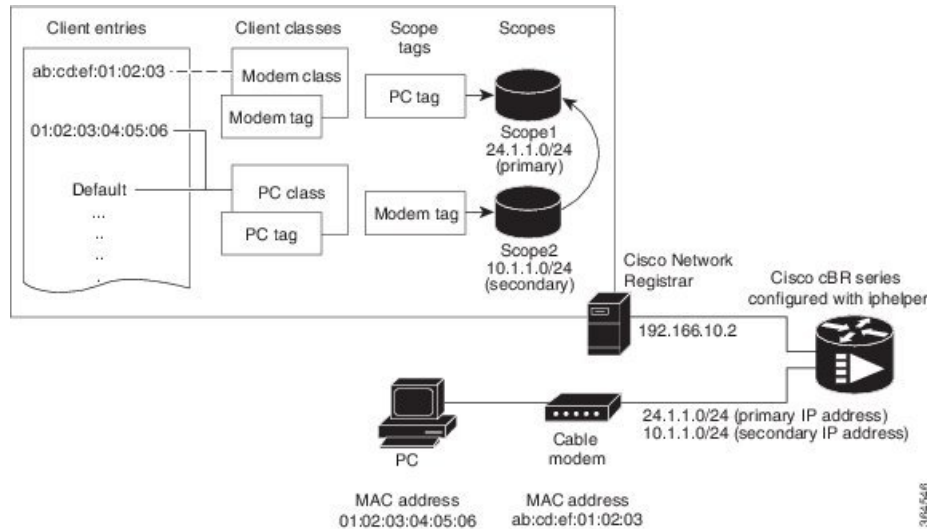

These configuration items and their associations can be created using either the CNR management graphical user interface (GUI) or command-line interface (CLI). The following sample script configures DHCP for a sample server:

```
File: cabledemo.rc
Command line: nrcmd -C <cluster> -N <user name> -P <password> -b < cabledemo.rc>
-----
scope-selection-tag tag-CM create
scope-selection-tag tag-PC create
client-class create class-CM
client-class class-CM set selection-criteria=tag-CM
client-class create class-PC
client-class class-PC set selection-criteria=tag-PC
policy cmts-cisco create
policy cmts-cisco setleasetime 1800
policy cmts-cisco setoption domain-name-servers 192.168.10.2
policy cmts-cisco setoption routers 10.1.1.1
policy cmts-cisco setoption time-offset 604800
policy cmts-cisco setoption time-servers 192.168.10.20
policy cmts-cisco set packet-siaddr=192.168.10.2
policy cmts-cisco setoption log-servers 192.168.10.2
policy cmts-cisco setoption mcns-security-server 192.168.10.2
policy cmts-cisco set packet-file-name=golden.cfg
policy cmts-cisco set dhcp-reply-options=packet-file-name,packet-siaddr,mcns-security-server
policy pPC create
policy pPC set server-lease-time 1800
policy pPC setleasetime 1800
policy pPC setoption domain-name-servers 192.168.10.2
policy pPC setoption routers 24.1.1.1
scope S24.1.1.0 create 24.1.1.0 255.255.255.0
scope S24.1.1.0 addrange 24.1.1.5 24.1.1.254
scope S24.1.1.0 set policy=pPC
scope S24.1.1.0 set selection-tags=tag-PC
scope S10.1.1.0 create 10.1.1.0 255.255.255.0
```



```

scope S10.1.1.0 addrange 10.1.1.5 10.1.1.254
scope S10.1.1.0 set policy=cmts-cisco
scope S10.1.1.0 set selection-tags=tag-CM
scope S10.1.1.0 set primary-scope=S24.1.1.0
client 01:02:03:04:05:06 create client-class-name=class-PC
client ab:cd:ef:01:02:03 create client-class-name=class-CM
client default create action=exclude
dhcp enable client-class
dhcp enable one-lease-per-client
save
dhcp reload

```

In addition to the DHCP server setup, you might want to enable packet-tracing. When packet-tracing is enabled, the server parses both requests and replies, and then adds them to the logs. If you do enable tracing, performance will be adversely affected, and the logs will roll over quickly.

Use the following nrcmd command to set packet tracing.

```
DHCP set log-settings=incoming-packet-detail,outgoing-packet-detail
```

## Cable Modem DHCP Response Fields

Each cable interface on the broadband network requires the following fields in the DHCP response:

- CM's IP address
- CM's subnet mask



---

**Note** For cable operators with less experience in networking, you can fill in a guess based on the network number and indicate how your IP network is divided.

---

- Name of the DOCSIS configuration file on the TFTP server intended for the cable interface
- Time offset of the cable interface from the Universal Coordinated Time (UTC), which the cable interface uses to calculate the local time when time-stamping error logs
- Time server address from which the cable interface obtains the current time

## DOCSIS DHCP Fields

DOCSIS DHCP option requirements include:

- IP address of the next server to use in the TFTP bootstrap process; this is returned in the siaddr field
- DOCSIS configuration file that the cable interface downloads from the TFTP server



---

**Note** If the DHCP server is on a different network that uses a relay agent, then the relay agent must set the gateway address field of the DHCP response.

---

- IP address of the security server should be set if security is required

## DHCP Relay Option (DOCSIS Option 82)

DOCSIS Option82 modifies DHCPDISCOVER packets to distinguish cable interfaces from the CPE devices or “clients” behind them. The DOCSIS Option82 is comprised of the following two suboptions:

- Suboption 1, Circuit ID:

```
Type 1 (1 byte)
Len 4 (1 byte)
Value (8 bytes)
<bit 31,30,.....0)
<xYYYYYYYYYYYYYYYYYYYYYYYYYYYY>
```

where the MSB indicates if the attached device is a cable interface.

x=1 Cable Modem REQ

x=0 CPE device (Behind the cable interface with the cable interface MAC address shown in suboption 2.)

The rest of the bits make up the SNMP index to the CMTS interface.

Y=0xYYYYYYY is the SNMP index to the CMTS interface.

- Suboption 2, MAC address of the cable interface:

```
Type 2 (1 byte)
Len 6 (1 byte)
Value xxxx.xxxx.xxxx (6 bytes)
```

## Overview of Scripts

This section lists the scripts applicable to cable interface configuration.

### Two-way Cable Modem Scripts

To support two-way configurations at a subscriber site, use these scripts:

- **Relay.tcl**
- **SetRouter.tcl**

### Telco Return Cable Modem Scripts

To support telco return and two-way cable interface configurations on the same cable interface card or chassis, use these scripts:

- **PostClientLookup.tcl**
- **PrePacketEncode.tcl**

# Placement of Scripts

## Windows NT

For CNR running on Windows NT, place the appropriate scripts in the following directory:

```
\program files\network registrar\extensions\dhcp\scripts\tcl
```

## Solaris

For CNR running on Solaris, place the appropriate scripts in the following directory:

```
/opt/nwreg2/extensions/dhcp/scripts/tcl
```

# Activating Scripts in Cisco Network Registrar

To activate the scripts after you have placed them in the appropriate directory:

---

**Step 1** Open up a text editor.

**Step 2** Open one of the scripts at the nrcmd> command prompt.

**Step 3** Create the extension points and attach them to the system.

**Note** The easiest way to do this is to simply cut and paste the command lines from the scripts to the nrcmd> command line.

**Step 4** After you have created and attached the extension points, do a dhcp reload.

The scripts are active.

---

# Configuring the Cisco CMTS Routers to Use Scripts

Each cable interface must be set up as a BOOTP forwarder and have the relay option enabled. The primary and secondary IP addresses for each cable interface must be in sync with the CNR tool.

To properly communicate with scripts in the system, use the following commands on the Cisco CMTS router:

- To enable option 82, use the **ip dhcp relay info option** command.
- To disable the validation of DHCP relay agent information in forwarded BOOTREPLY messages, use the **no ip dhcp relay information option check** command.



---

**Note** You can also use the `cable dhcp-giaddr` command in cable interface configuration mode to modify the `GIADDR` field of `DHCPDISCOVER` and `DHCPREQUEST` packets to provide a relay IP address before packets are forwarded to the DHCP server. Use this command to set a “policy” option such that primary addresses are used for CMs and secondary addresses are used for hosts behind the CMs.

---

## Configuring the System Default Policy

Add these options to the system default policy for:

- Cable modems to support on your network
- PCs to support behind each cable interface on your network

### Cable Modems

Define these settings following the CNR tool documentation:

- TFTP server (IP address) for those cable interfaces using BOOTP
- Time-server (IP address)
- Time-offset (Hex value, 1440 for Eastern Standard Time)
- Packet-siaddr (IP address of CNR)
- Router (set to 0.0.0.0)
- Boot-file (name of .cm file for those cable interfaces using BOOTP)
- Packet-file-name (.cm file name)

### PCs

Define these settings following the CNR tool documentation:

- Domain name
- Name servers (IP address of DNS servers)

## Creating Selection Tag Scopes

### General

When you create your scope selection tags:

---

**Step 1** Cut and paste the scope selection tag create commands from the scripts into the `nrmd>` command line.

**Note** These names have to be exactly as they appear in the scripts.

**Step 2** Then attach the selection tags to the appropriate scripts:

Example:

CM\_Scope tagCablemodem

PC\_Scope tagComputer

## Telco Return for the Cisco cBR-8 Router

### Before you begin



**Note** If you are using the `prepacketencode` and `postclientlookup` .tcl scripts for telco return, the telco return scope does not have a selection tag associated to the scope.

### SUMMARY STEPS

1. Put the tag `Telcocablemodem` on the primary cable interface scope to pull addresses from that pool instead.
2. Follow the same procedure as above, but use a telco return policy which has a different .cm file with telco-specific commands in it.

### DETAILED STEPS

- 
- Step 1** Put the tag `Telcocablemodem` on the primary cable interface scope to pull addresses from that pool instead.
- Step 2** Follow the same procedure as above, but use a telco return policy which has a different .cm file with telco-specific commands in it.
- 

## Creating Network Scopes

Following is an example for creating scopes for your network. This example assumes two Cisco cBR-8 converged broadband routers in two locations, with one cable interface card on one Cisco cBR-8 configured for telco return.

```
cm-toledo1_2-0 10.2.0.0 255.255.0.0 assignable 10.2.0.10-10.2.254.254 tagCablemodem
tagTelcomodem Default GW=10.2.0.1 (assigned by scripts)
cm-toledo1_3-0 10.3.0.0 255.255.0.0 assignable 10.3.0.10-10.3.254.254 tagCablemodem
tagTelcomodem Default GW=10.3.0.1 (assigned by scripts)
pc-toledo1_2-0 208.16.182.0 255.255.255.248 assignable 208.16.182.2-208.16.182.6 tagComputer
Default GW=208.16.182.1 (assigned by scripts)
pc-toledo1_3-0 208.16.182.8 255.255.255.248 assignable 208.16.182.10-208.16.182.14 tagComputer
Default GW=208.16.182.9 (assigned by scripts)
telco_return_2-0 192.168.1.0 255.255.255.0 (No assignable addresses, tag was put on cable
modem primary scope to force telco-return cable modem to pull address from primary scope)
cm-arlington1_2-0 10.4.0.0 255.255.0.0 assignable 10.4.0.10-10.4.254.254 tagCablemodem
Default GW=10.4.0.1 (assigned by scripts)
cm-arlington1_3-0 10.5.0.0 255.255.0.0 assignable 10.5.0.10-10.5.254.254 tagCablemodem
Default GW=10.5.0.1 (assigned by scripts)
pc-arlington1_2-0 208.16.182.16 255.255.255.248 assignable 208.16.182.17-208.16.182.22
tagComputer Default GW=208.16.182.17 (assigned by scripts)
```

```
pc-toledo1_3-0 208.16.182.24 255.255.255.248 assignable 208.16.182.2-208.16.182.30 tagComputer
Default GW=208.16.182.25 (assigned by scripts)
```



---

**Note** Remember the last valid address in the .248 subnet range is the broadcast address; do not use this.

---

## Creating Policies for Class of Service or for Upgrading Cable Modem Cisco IOS Images

To support Class of Service (CoS), define:

- Scope selection tags—Identifiers that describe types of scope configurations



---

**Note** This is needed for Option82.

---

- Client classes—Class with which a group of clients is associated



---

**Note** Scope selection tags are excluded from or included in client-classes.

---

- Client—Specific DHCP clients and the defined class to which they belong

To assign the CoS or use Option82, make a client entry with a MAC address and point to the appropriate policy. To use client-based MAC provisioning, add a client entry “default - exclude,” then put in MAC addresses for all devices (for example, cable interfaces and PCs) in the client tab and select the policy to use, including the appropriate tag.

## CNR Steps to Support Subinterfaces

The CNR configuration is done differently if subinterfaces are configured. Here is an example. If you have configured two ISP subinterfaces and one management subinterface on a Cisco cBR-8 router, make sure that the management subinterface is the first subinterface that is configured. If cable interface three—c3/0/0—is being used, create c3/0/0.1, c3/0/0.2 and c3/0/0.3 as three subinterfaces and c3/0/0.1 as the first subinterface configured as the management subinterface.



---

**Note** The Cisco cBR-8 router requires management subinterfaces to route DHCP packets from CMs when they first initialize because the Cisco cBR-8 router does not know the subinterfaces they belong to until it has seen the IP addresses assigned to them by gleaning DHCP reply message from CNR.

---

In CNR, complete the following steps for such a configuration:

## SUMMARY STEPS

1. Create two scope selection tags such as: isp1-cm-tag and isp2-cm-tag
2. Configure three scopes; for example, mgmt-scope, isp1-cm-scope, and isp2-cm-scope such that isp1-cm-scope and isp2-cm-scope each define mgmt-scope to be the primary scope
3. Also configure two scopes for PCs for each of the ISPs; isp1-pc-scope and isp2-pc-scope. For scope isp1-cm-scope, configure isp1-cm-tag to be the scope selection tag. For scope isp2-cm-scope, configure isp2-cm-tag to be the scope selection tag
4. Configure two client classes; for example, isp1-client-class and isp2-client-class
5. Create client entries with their MAC addresses for CMs that belong to ISP1 and assign them to isp1-client-class. Also assign the scope selection tag isp1-cm-tag
6. Create client entries for CMs that belong to ISP2 and assign them to isp2-client-class. Also assign the scope selection tag isp2-cm-tag
7. Enable client class processing from the scope-selection-tag window

## DETAILED STEPS

- 
- Step 1** Create two scope selection tags such as: isp1-cm-tag and isp2-cm-tag
- Step 2** Configure three scopes; for example, mgmt-scope, isp1-cm-scope, and isp2-cm-scope such that isp1-cm-scope and isp2-cm-scope each define mgmt-scope to be the primary scope
- Step 3** Also configure two scopes for PCs for each of the ISPs; isp1-pc-scope and isp2-pc-scope. For scope isp1-cm-scope, configure isp1-cm-tag to be the scope selection tag. For scope isp2-cm-scope, configure isp2-cm-tag to be the scope selection tag
- Step 4** Configure two client classes; for example, isp1-client-class and isp2-client-class
- Step 5** Create client entries with their MAC addresses for CMs that belong to ISP1 and assign them to isp1-client-class. Also assign the scope selection tag isp1-cm-tag
- Step 6** Create client entries for CMs that belong to ISP2 and assign them to isp2-client-class. Also assign the scope selection tag isp2-cm-tag
- Step 7** Enable client class processing from the scope-selection-tag window

Overlapping address ranges cannot be configured on these subinterfaces because software gleans the DHCP reply to figure out the subinterface it really belongs to. Although CNR can be configured with overlapping address range scopes, it cannot be used to allocate addresses from these scopes.

---

## Additional References

The following sections provide references related to Cisco Network Registrar for use with the Cisco CMTS routers.

**Technical Assistance**

| Description                                                                                                                                                                                                                                                              | Link                                                                                                              |
|--------------------------------------------------------------------------------------------------------------------------------------------------------------------------------------------------------------------------------------------------------------------------|-------------------------------------------------------------------------------------------------------------------|
| Technical Assistance Center (TAC) home page, containing 30,000 pages of searchable technical content, including links to products, technologies, solutions, technical tips, and tools. Registered Cisco.com users can log in from this page to access even more content. | <a href="http://www.cisco.com/cisco/web/support/index.html">http://www.cisco.com/cisco/web/support/index.html</a> |





## PART **X**

# PacketCable and PacketCable Multimedia Configuration

- [PacketCable and PacketCable Multimedia, on page 1343](#)
- [COPS Engine Operation, on page 1381](#)





## CHAPTER 86

# PacketCable and PacketCable Multimedia

This document describes how to configure the Cisco CMTS for PacketCable and PacketCable Multimedia operations over an existing DOCSIS (1.1 and later versions) network.

- [Finding Feature Information, on page 1343](#)
- [Hardware Compatibility Matrix for the Cisco cBR Series Routers, on page 1344](#)
- [Restrictions for PacketCable Operations, on page 1345](#)
- [Information About PacketCable Operations, on page 1345](#)
- [How to Configure PacketCable Operations, on page 1351](#)
- [Configuration Examples for PacketCable, on page 1359](#)
- [Verifying PacketCable Operations, on page 1362](#)
- [Information About PacketCable Multimedia Operations, on page 1366](#)
- [How to Configure PCMM Operations, on page 1370](#)
- [Configuration Examples for PacketCable Multimedia, on page 1372](#)
- [Verifying PCMM Operations, on page 1373](#)
- [High Availability Stateful Switchover \(SSO\) for PacketCable and PacketCable MultiMedia, on page 1375](#)
- [Voice MGPI Support, on page 1375](#)
- [Additional References, on page 1378](#)
- [Feature Information for PacketCable and PacketCable Multimedia, on page 1379](#)

## Finding Feature Information

Your software release may not support all the features that are documented in this module. For the latest feature information and caveats, see the release notes for your platform and software release. The Feature Information Table at the end of this document provides information about the documented features and lists the releases in which each feature is supported.

Use Cisco Feature Navigator to find information about platform support and Cisco software image support. To access Cisco Feature Navigator, go to <http://tools.cisco.com/ITDIT/CFN/>. An account on <http://www.cisco.com/> is not required.

# Hardware Compatibility Matrix for the Cisco cBR Series Routers



**Note** The hardware components that are introduced in a given Cisco IOS-XE Release are supported in all subsequent releases unless otherwise specified.

**Table 275: Hardware Compatibility Matrix for the Cisco cBR Series Routers**

| Cisco CMTS Platform                    | Processor Engine                                                                                                                                                                                  | Interface Cards                                                                                                                                                                                                                                                                                                                                                                                                                                                                                                                                                                                                                                                                                                                                                                                 |
|----------------------------------------|---------------------------------------------------------------------------------------------------------------------------------------------------------------------------------------------------|-------------------------------------------------------------------------------------------------------------------------------------------------------------------------------------------------------------------------------------------------------------------------------------------------------------------------------------------------------------------------------------------------------------------------------------------------------------------------------------------------------------------------------------------------------------------------------------------------------------------------------------------------------------------------------------------------------------------------------------------------------------------------------------------------|
| Cisco cBR-8 Converged Broadband Router | <p><b>Cisco IOS-XE Release 16.5.1 and Later Releases</b></p> <p>Cisco cBR-8 Supervisor:</p> <ul style="list-style-type: none"> <li>• PID—CBR-SUP-250G</li> <li>• PID—CBR-CCAP-SUP-160G</li> </ul> | <p><b>Cisco IOS-XE Release 16.5.1 and Later Releases</b></p> <p>Cisco cBR-8 CCAP Line Cards:</p> <ul style="list-style-type: none"> <li>• PID—CBR-LC-8D30-16U30</li> <li>• PID—CBR-LC-8D31-16U30</li> <li>• PID—CBR-RF-PIC</li> <li>• PID—CBR-RF-PROT-PIC</li> <li>• PID—CBR-CCAP-LC-40G</li> <li>• PID—CBR-CCAP-LC-40G-R</li> <li>• PID—CBR-CCAP-LC-G2-R</li> <li>• PID—CBR-SUP-8X10G-PIC</li> <li>• PID—CBR-2X100G-PIC</li> </ul> <p>Digital PICs:</p> <ul style="list-style-type: none"> <li>• PID—CBR-DPIC-8X10G</li> <li>• PID—CBR-DPIC-2X100G</li> </ul> <p>Cisco cBR-8 Downstream PHY Module:</p> <ul style="list-style-type: none"> <li>• PID—CBR-D31-DS-MOD</li> </ul> <p>Cisco cBR-8 Upstream PHY Modules:</p> <ul style="list-style-type: none"> <li>• PID—CBR-D31-US-MOD</li> </ul> |



**Note** Do not use DPICs (8X10G and 2x100G) to forward IP traffic, as it may cause buffer exhaustion, leading to line card reload.

The only allowed traffic on a DPIC interface is DEPI, UEPI, and GCP traffic from the Cisco cBR-8 router to Remote PHY devices. Other traffic such as DHCP, SSH, and UTSC should flow via another router, since DPICs cannot be used for normal routing.

## Restrictions for PacketCable Operations

- Supports only embedded multimedia terminal adapter (E-MTA) clients. Standalone MTA (S-MTA) clients are not supported.
- PacketCable operations can be configured together with HCCP N+1 redundancy, but the PacketCable states are not synchronized between the Working and Protect interfaces. If a switchover occurs, existing voice calls continue, but when the user hangs up, PacketCable event messages are not generated because the Protect interface is not aware of the previous call states. However, new voice calls can be made and proceed in the normal fashion.
- The 200,000 Hz channel width cannot be used on upstreams that support PacketCable voice calls, or on any upstreams that use Unsolicited Grant Service (UGS) or UGS with Activity Detection (UGS-AD) service flows. Using this small a channel width with voice and other UGS/UGS-AD service flows results in calls being rejected because of “DSA MULTIPLE ERRORS”.

## Information About PacketCable Operations

This section provides an overview and other information about PacketCable operations, the components of a PacketCable network, and how they interact with the other components of a DOCSIS cable networks.

### Feature Overview

PacketCable is a program initiative from Cablelabs and its associated vendors to establish a standard way of providing packet-based, real-time video and other multimedia traffic over hybrid fiber-coaxial (HFC) cable networks. The PacketCable specification is built upon the Data-over-Cable System Interface Specifications (DOCSIS) 1.1, but it extends the DOCSIS protocol with several other protocols for use over noncable networks, such as the Internet and the public switched telephone network (PSTN).

This allows PacketCable to be an end-to-end solution for traffic that originates or terminates on a cable network, simplifying the task of providing multimedia services over an infrastructure composed of disparate networks and media types. It also provides an integrated approach to end-to-end call signaling, provisioning, quality of service (QoS), security, billing, and network management.

## Emergency 911 Features

### PacketCable Emergency 911 Cable Interface Line Card Prioritization

The PacketCable Emergency 911 cable interface line card prioritization feature enables cable interface line cards that are supporting an Emergency 911 call to be given automatic priority over cable interface line cards supporting non-emergency voice calls, even in the case of HCCP switchover events. In such cases, Protect HCCP line card interfaces automatically prioritize service to Emergency 911 voice calls, should Working HCCP cable interface line cards be disrupted. This feature is enabled by default, and may not be disabled with manual configuration.



---

**Note** Emergency 911 cable interface line card prioritization applies only to PacketCable voice calls.

---

During HCCP switchover events, cable modems recover in the following sequence:

1. Cable modems supporting Emergency 911 voice traffic
2. Cable modems supporting non-emergency voice traffic
3. Cable modems that are nearing a T4 timeout event, in which service would be disrupted
4. Remaining cable modems

To view information about Emergency 911 voice events and cable interface line card prioritization on the Cisco CMTS router, use the `show hccp`, `show cable calls`, and `show hccp event-history` commands in privileged EXEC mode.

### PacketCable Emergency 911 Services Listing and History

The enhanced informational support for PacketCable Emergency 911 calls on the Cisco CMTS router provides the following information and related history:

- active Emergency 911 calls
- recent Emergency 911 calls
- regular voice calls
- voice calls made after recent Emergency 911 calls

This feature is enabled and supported with the following configuration and show commands:

- `cable high-priority-call-window`
- **show cable calls**
- **show cable modem calls**

To set the call window (in minutes) during which the Cisco CMTS router maintains records of Emergency 911 calls, use the `cable high-priority-call-window` command in global configuration mode. To remove the call window configuration from the Cisco CMTS router, use the **no** form of this command:

## PacketCable Network Components

A PacketCable network contains a number of components. Some components are the same as those that exist in a DOCSIS 1.1 network, while other components are new entities that create the end-to-end infrastructure that the PacketCable network needs to establish calls. Wherever possible, the PacketCable components and protocols build on existing protocols and infrastructures to simplify implementation and interoperability.

- Cable modem—A customer premises equipment (CPE) device that connects to a DOCSIS 1.0 or DOCSIS 1.1 cable network. All DOCSIS cable modems provide high-speed data connectivity to the Internet, while other cable modems can provide additional features, such as telephone connectivity.
- Cable Modem Termination System (CMTS)—A headend-based router that connects a DOCSIS cable network to the IP backbone network. The CMTS controls the DOCSIS 1.1 MAC layer and enforces the quality of service (QoS) limits that the cable operator guarantees to its subscribers. A typical CMTS services between several hundred and several thousand cable modems.



---

**Note** See the DOCSIS 1.1 specifications for information about cable modem and CMTS operations.

---

- Multimedia terminal adapter (MTA)—A CPE device that connects telephones and other end-user devices to the PacketCable network. The PacketCable specification defines two MTA types, an embedded MTA (E-MTA) and a standalone MTA (S-MTA). The E-MTA is an MTA integrated into a DOCSIS 1.1 cable modem, while the S-MTA is a separate MTA that requires a DOCSIS 1.1 cable modem to connect to the cable network.
- Call management server (CMS)—A centrally located server that provides the signaling functions that allow MTAs to establish calls over the network. The CMS uses the Network-based call signaling (NCS) protocol to provide authentication and authorization, call routing, and support for special features such as three-way calling. A PacketCable network could have multiple CMS servers, depending on its size and complexity.



---

**Note** The CMS implements several protocols on top of the Common Open Policy Service (COPS) protocol to communicate with the rest of the PacketCable network.

---

- Gate controller (GC)—A server that controls the establishment of gates in the PacketCable network. A gate is a logical entity in the CMTS that ensures that a service flow is authorized for the QoS features it is requesting. A separate gate controls the upstream and downstream directions of a service flow. When a call is established, the GC instructs the CMTS to create each gate and supplies the set of authorized parameters for each gate, which the CMTS uses to authorize the QoS requests that the MTA is making for the call. The GC is also responsible for coordinating the creation of the two sets of gates at each end of the call so that the call can be authorized and established.



---

**Note** A PacketCable network can contain multiple GCs, although only one server at a time is in control of any particular call. Typically, the same workstation provides both the CMS and GC servers.

---

- Record keeping server (RKS)—Billing server that collects the information about each call as it is made. The RKS uses the Remote Authentication Dial-In User Service (RADIUS) protocol to collect the billing data from the CMTS and other PacketCable servers. The RKS generates a call data record (CDR) for every call and forwards that information to the appropriate application server at the service provider's data processing center for further processing.

## Dynamic Quality of Service

A key feature of a PacketCable network is a dynamic quality of service (DQoS) capability that is similar to the dynamic services provided by DOCSIS 1.1. However, DOCSIS 1.1 DQoS authorizes and provisions

services only in the cable network and does not reserve the resources needed to propagate a call from one endpoint to another across the network.

The PacketCable DQoS extends the DOCSIS 1.1 services across the entire network, so that resources can be dynamically authorized and provisioned from one endpoint to another. This prevents possible theft-of-service attacks and guarantees customers the services they are authorized to use.



---

**Note** PacketCable 1.0 requires that DOCSIS 1.1 be used for resource reservation within the cable network for E-MTA clients.

---

## Two-Stage Resource Reservation Process

The PacketCable DQoS model uses a two-stage resource reservation process, in which resources are first reserved and then committed. This allows a bidirectional reservation process that ensures that resources are available at both endpoints of the connection before actually placing the call.

When an MTA makes a call request, the local CMTS communicates with the gate controller to authorize the call's resources. After the resources are authorized, the CMTS reserves the local resources while it negotiates with the remote end for the resources that are required at that end.



---

**Note** The CMTS uses DOCSIS 1.1 Dynamic Service Addition (DSA) messages to reserve the resources, and then uses Dynamic Service Change (DSC) messages to commit the resources.

---

When all required resources are available, the local CMTS and remote CMTS both commit the resources, allowing traffic to flow. Usage accounting and billing do not begin until the remote MTA picks up and the call is actually in progress.

The DQoS model ensures that both endpoints of a call, as well as the backbone network, have reserved the same bandwidth, and that the bandwidth is reserved only while the call is in progress. When a call terminates, all portions of the network can release the call's resources and make them available for other users.

## Making a Call Using DQoS

DOCSIS 1.1 networks use service flows to implement different QoS policies, but service flows exist only within the cable network. To control the service flows and to extend them across the entire network, a PacketCable network creates and maintains "gates."

A gate is a logical entity created on the CMTS at each side of a connection that authorizes and establishes a particular DQoS traffic flow. The CMTS communicates with the gate controller to coordinate the creation of matching gates at each side of the connection.

Gates are unidirectional, so separate gates are required for the downstream and upstream traffic flows. The same gate ID, however, is usually used for the downstream and upstream gates for a call. Each CMTS maintains its own set of gates, so a bidirectional traffic flow requires four gates to be created, two gates on the local CMTS and two gates on the remote CMTS.

For a typical call, gates progress through the following stages to create a DQoS traffic flow:

1. The local MTA makes a call request, and the gate controller sends a Gate-Allocation command to the CMTS, which creates a gate in response and puts it into the Allocated state.



2. The call management server, which might be the same server as the gate controller, parses the call request to translate the destination phone number into the appropriate destination gateway.
3. The gate controller verifies that the MTA making the call request is authorized for the required resources and sends a Gate-Set command to the CMTS, which puts the gate into the Authorized state.
4. The CMTS on each side of the connection reserves the local resources needed for the call, putting the gate into the Reserved state.
5. As the remote CMTS and local CMTS perform gate coordination, their respective gates get put into the Local\_Committed and Remote\_Committed states.
6. When both sides have reserved all required resources, each CMTS puts its gates into the Committed state, allowing traffic to flow.

## DQoSLite Based IPv6 Voice Support

DQoSLite is a modem centric solution without notion of gates, to validate and deliver residential voice services over IPv6 to reclaim IPv4 address space. CMTS does not participate in resource reservation and authorization.

DQoSLite leverages elements from PacketCable 2.0. It is SIP based, its provision mechanism is similar to PacketCable 2.0 and it can be part of an IP Multimedia Subsystem (IMS) infrastructure for the ISP.

The key factors for deploying IPv6 voice solution on this new DQoSLite infrastructure are as follows:

- It is SIP or IMS based.
- Support for a wide range of multimedia services.
- To reclaim some IPv4 address space.

This feature is enabled and supported with the following configuration and show commands:

- **packetcable authorize vanilla-docsis-mta**
- **show cable modem** {ip-address | mac-address} **qos**
- **show cable modem** {ip-address | mac-address} **service-flow**
- **show interface cable** slot/subslot/cable-interface-index **sid** sid
- **show interface cable** slot/subslot/cable-interface-index **service-flow** sfid

## Dynamic Service Transaction ID Support

DOCSIS 2.0 mandates unique Transaction IDs (TAIDs) across transactions. The TAIDs must be unique and not incremented. The TAIDs are assigned by the senders and sometimes the TAID timeout is mismatched between senders and receivers. This affects the uniqueness of the TAID.

A TAID can be reused when the sender finishes a transaction. Similarly, DOCSIS allows the receiver to identify a transaction by TAID without the SFID. Problems arise in DSD transaction and DSA/DSC interrupted transactions, when these two requirements are combined.

The uniqueness of TAID must be ensured to resolve the interoperability issue. This is done by making the CMTS wait until T10 to reuse the same TAID. A new TAID allocation algorithm is used to fulfill this requirement.

It creates a TAID pool to replace the existing 16-bit counter. This TAID pool is monitored by timers to track the TAID expiration. A flag is assigned to each TAID in the pool to indicate its availability. When new TAID

is requested, the dynamic service process checks the availability of the TAID. If the TAID is available, it is allocated to the new service flow, else the request is rejected.

Once the TAID is allocated, the timer starts with T10 expiration time and the TAID flag is set to FALSE to indicate the unavailability of TAID. The dynamic service process keeps track of the timer. When the time expires, the timer stops and the flag is set to TRUE to indicate the availability of TAID.

The TAID pool is allocated and initialized at the process initialization. All timers associated with the TAIDs are added as leaf timers to the process' parent timer.

## PacketCable Subscriber ID Support

The PacketCable Subscriber ID feature adds a subscriber ID to all Gate Control messages and enhances error codes returned from the Cisco CMTS router.

Previously, the Gate ID was unique only to individual CMTS systems, with the CMTS proxying all CMS Gate Control messaging through a central device, which manages the CMTS connections on behalf of the CMS. The CMS had a single Common Open Policy Service (COPS) association to the proxy device. Therefore, the Gate IDs could be duplicated when using multiple CMTS systems.

A subscriber ID is added to each Gate Control message to disambiguate the Gate IDs between the CMS and proxy device. The subscriber ID parameter is added to the following COPS messages:

- GATE-INFO
- GATE-DELETE
- GATE-OPEN
- GATE-CLOSE

The subscriber ID is available at the CMS and is used in the Gate-Set messages. Additionally, the error codes returned from CMTS or its proxy are enhanced to include more specific information about gate operation failures.

To enable this feature, use the **packetcable gate send-subscriberID** command in global configuration mode.

## Benefits

The PacketCable feature offers the following benefits to service providers and their customers:

### Integrated Services on a Cable Network

PacketCable allows cable operators the ability to offer multimedia, real-time services, in addition to data connectivity, across their entire network. These services could include basic telephony with lifeline support, as well as telephony that offers competitive extended calling services. Operators can deploy new services while heavily leveraging their existing network infrastructures.

The widespread use of IP as the standard transport mechanism for data networks today is enabling many advanced Internet applications such as multimedia e-mail, real-time chat, streaming media (including music and video), and videoconferencing. The PacketCable initiative provides the network architecture for a cable operator to deliver these services quickly and economically.

### Standardized Provisioning

PacketCable provides a standardized, efficient method to provision IP services for individual subscribers, because PacketCable specifications define a uniform, open, and interoperable network. Cable operators are assured of standardized provisioning and the associated lower costs of deployment.

### Interoperability

Customer premises equipment (CPE) devices account for a major portion of the capital expense in deploying a VoIP solution at a cable plant. The PacketCable specifications ensure that vendors will build MTA clients that support the voice and other services that cable operators plan to deploy. Because these CPE devices are based on existing DOCSIS-compliant cable modems, time and cost of development is minimized.

Interoperability with the other components of the PacketCable network is also guaranteed because of the standards-based approach to the specifications. Any PacketCable-certified component will be able to interoperate within a network that conforms to the PacketCable standards.

### Secure Architecture

Because PacketCable is built upon the security features available in DOCSIS 1.1, cable operators will be assured of networks that are secure from end to end, with a high standard of security that prevents the most common theft-of-service attacks. The comprehensive, standards-based PacketCable specifications are designed to create a network that is as secure as the public switched telephone network (PSTN).

### CALEA Support

The PacketCable architecture was designed to accommodate the 1994 Communications Assistance for Law Enforcement Act (CALEA), which requires telecommunications carriers to assist law-enforcement agencies in conducting court-ordered electronic surveillance. PacketCable networks will be able to provide the two types of information that a carrier must provide, depending on the type of court order:

- Call-identifying information—The carrier must provide the call-identifying information for calls to or from an intercept target. For telephone calls, this information includes the phone numbers called by the target or calling the target.
- Call content—The carrier must provide the content of calls to or from an intercept target. For telephone calls, this real-time content is the voice conversation.

## How to Configure PacketCable Operations

This section contains the following tasks to configure the PacketCable feature. Each task is required unless otherwise identified as optional.

### Enabling PacketCable Operation

To enable PacketCable operation, use the following commands beginning in user EXEC mode. This is a required procedure.

---

**Step 1**    **enable**

**Example:**

```
Router> enable
```

Enables privileged EXEC mode. Enter your password if prompted.

**Step 2** **configure terminal****Example:**

```
Router# configure terminal
```

Enters global configuration mode.

**Step 3** **packetcable****Example:**

```
Router(config)# packetcable
```

Enables PacketCable operation on all cable interfaces.

**Step 4** **exit****Example:**

```
Router(config)# exit
```

Exits global configuration mode.

---

## Disabling PacketCable Operation

To disable PacketCable operation, use the following commands beginning in user EXEC mode. This procedure is required only when you no longer want the Cisco CMTS to support PacketCable signaling.

---

**Step 1** **enable****Example:**

```
Router> enable
```

Enables privileged EXEC mode. Enter your password if prompted.

**Step 2** **configure terminal****Example:**

```
Router# configure terminal
```

Enters global configuration mode.

**Step 3** **no packetcable****Example:**

```
Router(config)# no packetcable
```

Disables PacketCable operation on all cable interfaces.

**Step 4** `exit`**Example:**

```
Router(config)# exit
```

Exits global configuration mode.

---

## Configuring PacketCable Operation

To configure the different parameters that affect PacketCable operations, use the following commands beginning in user EXEC mode. All of these procedures are optional, because each parameter is set to a default that is appropriate for typical PacketCable operations.

---

**Step 1** `enable`**Example:**

```
Router> enable
```

Enables privileged EXEC mode. Enter your password if prompted.

**Step 2** `configure terminal`**Example:**

```
Router# configure terminal
```

Enters global configuration mode.

**Step 3** `packetcable element-id n`**Example:**

```
Router(config)# packetcable element-id 23
```

Configures the Event Message Element ID for the Cisco CMTS. If you do not manually configure the Element ID, the CMTS defaults to a random value between 0 and 99,999 when PacketCable operations are enabled.

**Step 4** `packetcable gate maxcount n`**Example:**

```
Router(config)# packetcable gate maxcount 524288
```

Sets the maximum number of gate IDs to be allocated in the gate database on the Cisco CMTS.

**Step 5** `packetcable timer T0 timer-value`**Example:**

```
Router(config)# packetcable timer T0 40000
```

Sets the T0 timer in milliseconds.

**Step 6**    **packetcable timer T1** *timer-value*

**Example:**

```
Router(config)# packetcable timer T1 300000
```

Sets the T1 timer in milliseconds.

**Step 7**    **exit**

**Example:**

```
Router(config)# exit
```

Exits global configuration mode.

---

## Enabling Both PacketCable and Non-PacketCable UGS Service Flows

By default, when PacketCable operations are enabled using the **packetcable** command, cable modems must follow the PacketCable protocol when requesting Unsolicited Grant Service (UGS) service flows. This prevents DOCSIS cable modems that do not support PacketCable operations from using DOCSIS-style UGS service flows.

If you have a mixed network that contains both PacketCable and non-PacketCable DOCSIS CMs, you can use the **packetcable authorize vanilla-docsis-mta** command to enable both types of UGS service flows. This is an optional procedure.

---

**Step 1**    **enable**

**Example:**

```
Router> enable
```

Enables privileged EXEC mode. Enter your password if prompted.

**Step 2**    **configure terminal**

**Example:**

```
Router# configure terminal
```

Enters global configuration mode.

**Step 3**    **packetcable**

**Example:**

```
Router(config)# packetcable
```

Enables PacketCable operations.

**Step 4**    **packetcable authorize vanilla-docsis-mta**

**Example:**

```
Router(config)# packetcable authorize vanilla-docsis-mta
```

Enables the use of DOCSIS-style UGS service flow requests.

**Step 5** **cable dsx authorization****Example:**

```
Router(config)# cable dsx authorization
```

Enables the dsx authorization.

**Step 6** **exit****Example:**

```
Router(config)# exit
```

Exits global configuration mode.

---

**What to do next**

---

**Tip** Use the **show packetcable global** command to display whether non-PacketCable UGS service flows have been enabled.

---

## Enabling PacketCable Subscriber ID Support

To include subscriber identification in GATE-OPEN and GATE-CLOSE Gate Control messages, use the **packetcable gate send-subscriberID** command in global configuration mode.

**Step 1** **enable****Example:**

```
Router> enable
```

Enables privileged EXEC mode. Enter your password if prompted.

**Step 2** **configure terminal****Example:**

```
Router# configure terminal
```

Enters global configuration mode.

**Step 3** **packetcable****Example:**

```
Router(config)# packetcable
```

Enables PacketCable operations.

**Step 4** **packetcable gate send-subscribeID****Example:**

```
Router(config)# packetcable gate send-subscribeID
```

Enables the use of gate control subscriber identification information.

**Step 5** **exit****Example:**

```
Router(config)# exit
```

Exits global configuration mode.

---

## Configuring RADIUS Accounting for RKS Servers

To enable the Cisco CMTS router to communicate with the Record Keeping Servers (RKS servers) using the RADIUS protocol, use the following commands. This is a required procedure.

**Step 1** **enable****Example:**

```
Router> enable
```

Enables privileged EXEC mode. Enter your password if prompted.

**Step 2** **configure terminal****Example:**

```
Router# configure terminal
```

Enters global configuration mode.

**Step 3** **aaa new-model****Example:**

```
Router(config)# aaa new-model
```

Enables the authentication, authorization, and accounting (AAA) access control model.

**Step 4** **aaa group server radius *group-name*****Example:**

```
Router(config)# aaa group server radius packetcable
```



Creates a group of RADIUS servers for authentication and enters RADIUS group configuration mode. The value of *group-name* is a unique, arbitrary string that identifies this group.

**Step 5**      **server** {*hostname* | *ip-address*} [**auth-port** *udp-port* ] [**acct-port** *udp-port* ]

**Example:**

```
Router(config-sg-radius)# server radius-server1
```

Specifies the host name or IP address for the RADIUS server that is providing the RKS services.

**Note** Repeat this command as needed to enter multiple RADIUS servers. The Cisco CMTS uses the servers in the order given with this command.

**Step 6**      **exit**

**Example:**

```
Router(config-sg-radius)# exit
```

Exits RADIUS group configuration mode.

**Step 7**      **aaa accounting network default start-stop group radius group** *group-name*

**Example:**

```
Router(config)# aaa accounting network default start-stop group radius group packetcable
```

Enables AAA services using the group of RADIUS servers that are defined in the previously created group. The *group-name* parameter should be the same name specified in Step 4 .

**Step 8**      **radius-server host** {*hostname* | *ip-address*} [**auth-port** *port-number*] [**acct-port** *port-number* ] [**timeout** *seconds* ] [**retransmit** *retries* ] **key** 0000000000000000

**Example:**

```
Router(config)# radius-server host radius-server1 key 0000000000000000
```

Specifies a RADIUS host. Use the same values for *hostname* or *ip-address* as for one of the servers specified in Step 5 . If you also specified the **auth-port** or **acct-port** values in Step 5 , you must also specify those here, as well. The **key** value is required and must be 16 ASCII zeros, as shown.

**Note** Repeat this command for each RADIUS server entered in Step 5 .

**Step 9**      **radius-server vsa send accounting**

**Example:**

```
Router(config)# radius-server vsa send accounting
```

Configures the Cisco CMTS to recognize and use accounting-related vendor-specific attributes (VSA).

**Step 10**     **exit**

**Example:**

```
Router(config)# exit
```

Exits global configuration mode.

---

### What to do next

#### Troubleshooting Tips

If the connection between a PacketCable CMS and the Cisco CMTS router is not completely established, and the PacketCable CMS does not correctly terminate the session by sending a TCP FIN message, the connection shows a COPS server in the output of the **show cops server** command.

## PacketCable Client Accept Timeout

The PacketCable Client Accept Timeout feature supports COPS for PacketCable on the Cisco CMTS router. This feature also allows you to set timeout values for COPS Telnet connections on the Cisco CMTS router, and for clearing COPS Telnet sessions.

Telnet errors on the network or Cisco CMTS router might cause incomplete COPS sessions to be created. In order to address this issue, the timeout timer enables clearing and cleaning of allocated resources for the stale COPS Telnet sessions on the Cisco CMTS router.

The timeout timer applies to each COPS Telnet connection on the Cisco CMTS router. When this timeout setting expires, it terminates the Telnet session and clears supporting resources on the Cisco CMTS router.

---

### Step 1 enable

#### Example:

```
Router> enable
```

Enables privileged EXEC mode.

- Enter your password if prompted.

### Step 2 configure terminal

#### Example:

```
Router# configure terminal
```

Enters global configuration mode.

### Step 3 packetcable timer {T0 timer-value | T1 timer-value | multimedia T1 timer-value}

#### Example:

```
Router(config)# packetcable timer T0 300000
```

#### Example:

```
Router(config)# packetcable timer T1 400000
```

#### Example:

```
Router(config)# packetcable timer multimedia T1 400000
```

Sets the PacketCable timer value.

**Step 4**    **end**

**Example:**

```
Router(config)# end
```

Returns to privileged EXEC mode.

### What to do next

### Troubleshooting Tips

If the connection between a PacketCable CMS and the Cisco CMTS router is not completely established, and the PacketCable CMS does not correctly terminate the session by sending a TCP FIN message, the connection shows a COPS server in the output of the **show cops server** command.

## Configuration Examples for PacketCable

This section provides a PacketCable configuration example.

### Example: Typical PacketCable Configuration

This section provides a typical configuration for a Cisco CMTS router that has been configured for PacketCable operations, using default parameters. To use this configuration, you must change the IP addresses for the RADIUS and RKS servers to match the addresses for the servers in your network.

```
!
version 15.5
no parser cache
no service pad
service timestamps debug datetime msec localtime show-timezone
service timestamps log datetime msec localtime show-timezone
no service password-encryption
service internal
service udp-small-servers max-servers no-limit
service tcp-small-servers max-servers no-limit
!
hostname Router
!
no logging rate-limit
aaa new-model
!
!
aaa group server radius a
  server 10.9.62.12 auth-port 1813 acct-port 1812
  server 10.9.62.13 auth-port 1813 acct-port 1812
!
aaa accounting network default start-stop group radius group a
aaa session-id common
enable password <delete>
!
cable modulation-profile 2 request 0 16 0 8 qpsk scrambler 152 no-diff 64 fixed uw16
```

## Example: Typical PacketCable Configuration

```

cable modulation-profile 2 initial 5 34 0 48 qpsk scrambler 152 no-diff 128 fixed uw16
cable modulation-profile 2 station 5 34 0 48 qpsk scrambler 152 no-diff 128 fixed uw16
cable modulation-profile 2 short 6 75 6 8 16qam scrambler 152 no-diff 144 shortened uw8
cable modulation-profile 2 long 8 220 0 8 16qam scrambler 152 no-diff 160 shortened uw8
cable modulation-profile 5 request 0 16 2 8 qpsk scrambler 152 no-diff 64 fixed uw16
cable modulation-profile 5 initial 5 34 0 48 qpsk scrambler 152 no-diff 128 fixed uw16
cable modulation-profile 5 station 5 34 0 48 qpsk scrambler 152 no-diff 128 fixed uw16
cable modulation-profile 5 short 6 78 7 8 16qam scrambler 152 no-diff 144 shortened uw16
cable modulation-profile 5 long 8 220 0 8 16qam scrambler 152 no-diff 160 shortened uw16
cable qos profile 5 max-burst 1200
cable qos profile 5 max-downstream 2000
cable qos profile 5 max-upstream 128
cable qos profile 5 priority 5
cable qos profile 5 privacy
cable qos profile 7 guaranteed-upstream 87
cable qos profile 7 max-upstream 87
cable qos profile 7 privacy
no cable qos permission create
no cable qos permission update
cable qos permission modems
cable qos permission enforce 5
cable time-server
no cable privacy accept-self-signed-certificate
ip subnet-zero
!
!
no ip domain-lookup
ip domain-name cisco.com
ip host tftp 10.8.8.8
ip host cnr 10.9.62.17
!
packetcable
packetcable element-id 12456
!
!
!
interface Tunnel0
 ip address 10.55.66.3 255.255.255.0
 load-interval 30
 tunnel source TenGigabitEthernet 4/1/0
 tunnel destination 172.27.184.69
!
interface Tunnel10
 ip address 10.0.1.1 255.255.0.0
!
interface TenGigabitEthernet 4/1/0
 ip address 10.9.60.10 255.255.0.0
 no ip redirects
 no ip mroute-cache
 full-duplex
!
interface TenGigabitEthernet 4/1/0
 ip address 172.22.79.44 255.255.254.0
 no ip redirects
 no ip mroute-cache
 full-duplex
!
interface Cable3/0
 ip address 10.3.1.33 255.255.255.0 secondary
 ip address 10.4.1.1 255.255.255.0 secondary
 ip address 10.4.1.33 255.255.255.0 secondary
 ip address 10.3.1.1 255.255.255.0
 ip helper-address 10.9.62.17
 load-interval 30

```

```

no keepalive
cable downstream annex B
cable downstream modulation 64qam
cable downstream interleave-depth 32
cable downstream frequency 55500000
cable upstream 0 modulation-profile 2
no cable upstream 0 shutdown
cable upstream 1 frequency 12000000
cable upstream 1 power-level 0
cable upstream 1 channel-width 3200000
cable upstream 1 data-backoff automatic
cable upstream 1 modulation-profile 2
cable upstream 1 shutdown
cable upstream 2 frequency 16000000
cable upstream 2 power-level 0
cable upstream 2 channel-width 3200000
cable upstream 2 data-backoff automatic
cable upstream 2 modulation-profile 2
no cable upstream 2 shutdown
cable upstream 3 frequency 20000000
cable upstream 3 power-level 0
cable upstream 3 channel-width 3200000
cable upstream 3 data-backoff automatic
cable upstream 3 modulation-profile 2
no cable upstream 3 shutdown
cable upstream 4 frequency 24000000
cable upstream 4 power-level 0
cable upstream 4 channel-width 3200000
cable upstream 4 data-backoff automatic
no cable upstream 4 shutdown
cable upstream 5 frequency 28000000
cable upstream 5 power-level 0
cable upstream 5 channel-width 3200000
cable upstream 5 data-backoff automatic
cable upstream 5 modulation-profile 2
no cable upstream 5 shutdown
cable dhcp-giaddr policy
!
router eigrp 48849
 network 1.0.0.0
 network 10.0.0.0
 auto-summary
 no eigrp log-neighbor-changes
!
ip default-gateway 10.9.0.1
ip classless
ip route 0.0.0.0 0.0.0.0 172.22.78.1
ip route 10.8.0.0 255.255.0.0 10.9.0.1
ip route 192.168.80.0 255.255.255.0 Tunnel0
ip route 192.168.80.0 255.255.255.0 172.27.184.69
ip route 10.255.254.254 255.255.255.255 10.9.0.1
no ip http server
ip pim bidir-enable
!
!
cdp run
!
!
radius-server host 10.9.62.12 auth-port 1813 acct-port 1812 key 0000000000000000
radius-server retransmit 3
radius-server vsa send accounting
!
line con 0
 exec-timeout 0 0

```

```

privilege level 15
line aux 0
line vty 0 4
  session-timeout 33
  exec-timeout 0 0
  password <deleted>
!
ntp clock-period 17179976
ntp server 1.9.35.8
end

```

## Verifying PacketCable Operations

To verify and maintain information about PacketCable operations, use one or more of the following commands:

- **show packetcable global**
- **show packetcable gate**
- **show packetcable gate ipv6**
- **show packetcable gate dqos**
- **show packetcable gate counter commit**

To verify the PacketCable configuration, values for the Element ID, maximum number of gates, and the different CMTS-based DQoS timers, use the **show packetcable global** command in privileged EXEC mode.

```

Router# show packetcable global
Packet Cable Global configuration:
Enabled      : Yes
Element-ID: 12456
Max Gates   : 1048576
Allow non-PacketCable UGS
Default Timer value -
  T0        : 30000 msec
  T1        : 300000 msec

```

To verify information about one or more gates in the gate database, use the **show packetcable gate** command as shown in the following example:

```

Router# show packetcable gate summary
GateID      i/f          SubscriberID  GC-Addr      State      Type  SFID(us)  SFID(ds)
13582      Ca8/1/0      3.18.1.4     20.5.0.254  RECOVERY  Dqos  74
29962      Ca8/1/0      3.18.1.5     20.5.0.254  RECOVERY  Dqos  73
46354      Ca8/1/0      -----     20.5.0.254  RECOVERY  Dqos  72
62738      Ca8/1/0      -----     20.5.0.254  RECOVERY  Dqos              69
Total number of gates = 4
Total Gates committed(since bootup or clear counter) = 8

```

To verify information about one or more PacketCable gates associated with IPv6 subscriber IDs in the gate database, use the **show packetcable gate ipv6** command as shown in the following example:

```

Router# show packetcable gate ipv6 summary
GateID      i/f          SubscriberID  State  SFID(us)  SFID(ds)
13582      Ca8/1/0      2001:40:1:42:C0B4:84E5:5081:9B5C  COMMIT  74
29962      Ca8/1/0      2001:40:1:42:C0B4:84E5:5081:9B5C  COMMIT  73
46354      Ca8/1/0      2001:40:1:42:C0B4:84E5:5081:9B5C  COMMIT  72
62738      Ca8/1/0      2001:40:1:42:C0B4:84E5:5081:9B5C  COMMIT              69
Total number of gates = 4
Total Gates committed(since bootup or clear counter) = 8

```

To verify information about one or more PacketCable gates associated with IPv4 subscriber IDs in the gate database, use the **show packetcable gate dqos** command as shown in the following example:

```
Router# show packetcable gate dqos summary
GateID      i/f          SubscriberID  GC-Addr      State      Type  SFID(us)  SFID(ds)
13576      Ca8/1/0     40.1.43.60   10.74.58.5  COMMIT    DQoS  527       528
29956      Ca8/1/0     40.1.43.56   10.74.58.5  COMMIT    DQoS  525       526
Total number of DQOS gates = 2
Total Gates committed(since bootup or clear counter) = 346
```

To verify the total number of gates that the Cisco CMTS router has moved to the Committed state since the router was last reset, or since the counter was last cleared, use the **show packetcable gate counter commit** command as shown in the following example:

```
Router# show packetcable gate counter commit
Total Gates committed (since bootup or clear counter) = 132
```

## Verifying Emergency 911 Calls

This section provides a few examples to illustrate how you can use the **show cable calls** and **show cable modem calls** commands to verify different scenarios associated with Emergency 911 calls.

The following example displays Emergency 911 calls made on the Cable8/1/1 interface on the Cisco CMTS router during the window set for high priority calls:

```
Router# show cable calls
Interface  ActiveHiPriCalls  ActiveAllCalls  PostHiPriCallCMs  RecentHiPriCMs
C5/0/0    0                  0                0                  0
C5/0/1    0                  0                0                  0
C5/1/0    0                  0                0                  0
C5/1/1    0                  0                0                  0
C5/1/2    0                  0                0                  0
C5/1/3    0                  0                0                  0
C5/1/4    0                  0                0                  0
C6/0/0    0                  0                0                  0
C6/0/1    0                  0                0                  0
C7/0/0    0                  0                0                  0
C7/0/1    0                  0                0                  0
C8/1/0    0                  0                0                  0
C8/1/1    1                  1                0                  0
C8/1/2    0                  0                0                  0
C8/1/3    0                  0                0                  0
C8/1/4    0                  0                0                  0
Total     1                  1                0                  0
```

The following example displays the change on the Cisco CMTS router when this Emergency 911 calls ends:

```
Router# show cable calls
Interface  ActiveHiPriCalls  ActiveAllCalls  PostHiPriCallCMs  RecentHiPriCMs
C5/0/0    0                  0                0                  0
C5/0/1    0                  0                0                  0
C5/1/0    0                  0                0                  0
C5/1/1    0                  0                0                  0
C5/1/2    0                  0                0                  0
C5/1/3    0                  0                0                  0
C5/1/4    0                  0                0                  0
C6/0/0    0                  0                0                  0
C6/0/1    0                  0                0                  0
```

|        |   |   |   |   |
|--------|---|---|---|---|
| C7/0/0 | 0 | 0 | 0 | 0 |
| C7/0/1 | 0 | 0 | 0 | 0 |
| C8/1/0 | 0 | 0 | 0 | 0 |
| C8/1/1 | 0 | 0 | 0 | 1 |
| C8/1/2 | 0 | 0 | 0 | 0 |
| C8/1/3 | 0 | 0 | 0 | 0 |
| C8/1/4 | 0 | 0 | 0 | 0 |
| Total  | 0 | 0 | 0 | 1 |

The following example displays information that is available when making a voice call from the same MTA to another MTA on the same interface:

```
Router# show cable calls
Interface  ActiveHiPriCalls  ActiveAllCalls  PostHiPriCallCMs  RecentHiPriCMs
C5/0/0    0                  0                0                  0
C5/0/1    0                  0                0                  0
C5/1/0    0                  0                0                  0
C5/1/1    0                  0                0                  0
C5/1/2    0                  0                0                  0
C5/1/3    0                  0                0                  0
C5/1/4    0                  0                0                  0
C6/0/0    0                  0                0                  0
C6/0/1    0                  0                0                  0
C7/0/0    0                  0                0                  0
C7/0/1    0                  0                0                  0
C8/1/0    0                  0                0                  0
C8/1/1    0                  2                1                  1
C8/1/2    0                  0                0                  0
C8/1/3    0                  0                0                  0
C8/1/4    0                  0                0                  0
Total     0                  2                1                  1
```

The following example displays information that is available when a voice call from the same MTA to another MTA on the same interface ends:

```
Router# show cable calls
Interface  ActiveHiPriCalls  ActiveAllCalls  PostHiPriCallCMs  RecentHiPriCMs
C5/0/0    0                  0                0                  0
C5/0/1    0                  0                0                  0
C5/1/0    0                  0                0                  0
C5/1/1    0                  0                0                  0
C5/1/2    0                  0                0                  0
C5/1/3    0                  0                0                  0
C5/1/4    0                  0                0                  0
C6/0/0    0                  0                0                  0
C6/0/1    0                  0                0                  0
C7/0/0    0                  0                0                  0
C7/0/1    0                  0                0                  0
C8/1/0    0                  0                0                  0
C8/1/1    0                  0                0                  1
C8/1/2    0                  0                0                  0
C8/1/3    0                  0                0                  0
C8/1/4    0                  0                0                  0
Total     0                  0                0                  1
```

The following examples display the show cable modem calls command output on the Cisco CMTS router over a period of time, with changing call status information. The call information disappears when a call ends.

```
Router# show cable modem calls
Cable Modem Call Status Flags:
H: Active high priority calls
R: Recent high priority calls
```



```

V: Active voice calls (including high priority)
MAC Address      IP Address      I/F      Prim  CMCallStatus  LatestHiPriCall
                  Sid              (min:sec)
0000.cab7.7b04 10.10.155.38   C8/1/1/U0 18    R              0:39
Router# show cable modem calls
Cable Modem Call Status Flags:
H: Active high priority calls
R: Recent high priority calls
V: Active voice calls (including high priority)
MAC Address      IP Address      I/F      Prim  CMCallStatus  LatestHiPriCall
                  Sid              (min:sec)

```

The following example displays a new Emergency 911 call on the Cisco CMTS router:

```

Router# show cable modem calls
Cable Modem Call Status Flags:
H: Active high priority calls
R: Recent high priority calls
V: Active voice calls (including high priority)
MAC Address      IP Address      I/F      Prim  CMCallStatus  LatestHiPriCall
                  Sid              (min:sec)
0000.cab7.7b04 10.10.155.38   C8/1/1/U0 18    HV             1:30

```

The following example displays the end of the Emergency 911 call on the Cisco CMTS router:

```

Router# show cable modem calls
Cable Modem Call Status Flags:
H: Active high priority calls
R: Recent high priority calls
V: Active voice calls (including high priority)
MAC Address      IP Address      I/F      Prim  CMCallStatus  LatestHiPriCall
                  Sid              (min:sec)
0000.cab7.7b04 10.10.155.38   C8/1/1/U0 18    R              0:3

```

The following example displays a non-emergency voice call on the Cisco CMTS router from the same MTA:

```

Router# show cable modem calls
Cable Modem Call Status Flags:
H: Active high priority calls
R: Recent high priority calls
V: Active voice calls (including high priority)
MAC Address      IP Address      I/F      Prim  CMCallStatus  LatestHiPriCall
                  Sid              (min:sec)
0000.ca36.f97d 10.10.155.25   C8/1/1/U0 5     V              -
0000.cab7.7b04 10.10.155.38   C8/1/1/U0 18    RV             0:30

```

The following example displays the end of the non-emergency voice call on the Cisco CMTS router:

```

Router# show cable modem calls
Cable Modem Call Status Flags:
H: Active high priority calls
R: Recent high priority calls
V: Active voice calls (including high priority)
MAC Address      IP Address      I/F      Prim  CMCallStatus  LatestHiPriCall
                  Sid              (min:sec)
0000.cab7.7b04 10.10.155.38   C8/1/1/U0 18    R              0:36

```

# Information About PacketCable Multimedia Operations

The PacketCable Multimedia (PCMM) feature is a powerful implementation of the CableLabs® standards for PacketCable Multimedia. PCMM provides enhanced QoS for multimedia applications, voice, and bandwidth-intensive services over a DOCSIS (DOCSIS 1.1 and later versions) network.

The Cisco CMTS router supports DOCSIS QoS for SIP-based telephones and SIP video phones, Bandwidth-on-Demand applications, and network-based gaming applications, all of which place extensive bandwidth demands on the network.

This section provides information about the following aspects of PacketCable Multimedia for the Cisco CMTS router, emphasizing PCMM components that are configured with the Cisco IOS command-line interface later in this document:

## PCMM Overview

The following network components are required to support the PCMM feature:

- Application Server—Responsible for relaying client requests to the Application Manager.
- Application Manager—Responsible for application or session-level state and for applying session control domain (SCD) policy.
- Policy Server—Responsible for applying the RCD policy and for managing relationships between the Application Manager and a Cisco CMTS router.
- Cisco CMTS router—Responsible for performing admission control and managing network resources through DOCSIS service flows.

Figure below provides an architectural overview of the PCMM functionality:

Figure 36: PCMM Architectural Overview

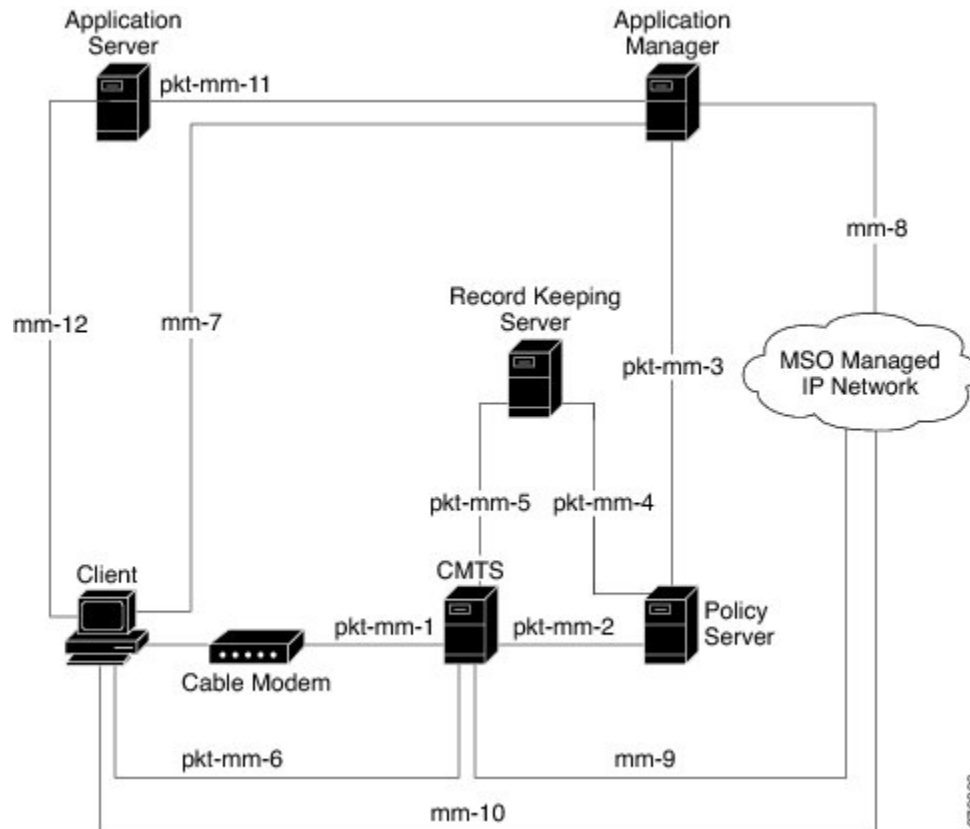

## PCMM Enhancements over PacketCable 1.x

PacketCable Multimedia is a service delivery framework that leverages and uses as much of existing PacketCable 1.x deployments and functionality as possible. Furthermore, PCMM offers powerful enhancements to the VoIP service delivery framework with straightforward CLI implementation. The key enhancements that the PCMM provides are:

- Time and volume based network resource authorizations are based on DOCSIS 1.1 Quality of Service (QoS) mechanisms.
- Event-based network resource auditing and management functions.
- Secure infrastructure that protects all interfaces at appropriate levels.
- Preauthorized model from PacketCable 1.x, where the PCMM gate installation and management is supplemented with service flow creation, modification and deletion functions. Together, these provide a secure, network-based QoS.

## PCMM and High Availability Features on the Cisco CMTS Router

High Availability on the Cisco CMTS router accommodates synchronization of service flows created for the PCMM applications and the PCCM gate.

## PCMM Gates

### PCMM Gate Overview and PCMM Dynamic Quality of Service

A PacketCable 1.x gate defines QoS parameters and policy-based authorization for subscribers, and a specific envelope of network resources. A PacketCable 1.x gate also maintains classifiers for originating and terminating IP addresses and ports.

The subscriber ID can identify both IPv4 and IPv6 addresses of either the cable modem or the client CPE.

PacketCable 1.x defines a preauthorization model. The PacketCable gates are created and installed at the Cisco CMTS router prior to network resource reservation or activation requests. This process, termed gate control, is managed through a COPS-based policy interface on the Cisco CMTS router.

In PCMM, this COPS-based interface is enhanced for QoS life-cycle management. PCMM gates maintain service flow creation, modification and deletion functions to provide for network-based QoS. Multiple PCMM gates and service flow policies can be maintained on the Cisco CMTS router at a given time, and these PCMM gates are fully interoperable with PacketCable 1.x gates.

When a cable modem subscriber requests bandwidth for a network-intensive application, the network Policy Server sends a Gate-Set message to the Cisco CMTS router. This message contains QoS, service flow, and billing information for this subscriber. This gate profile information is maintained on the Cisco CMTS router, to include PCMM gate states and PCMM state transitions.

The Cisco CMTS router initiates service flows with cable modems, and optimizes DOCSIS resource availability on the Cisco CMTS router for bandwidth-intensive service flows characteristic to PCMM.

#### Restrictions

On some upstream paths, best effort service flows are configured on some modems with Committed Information Rate (CIR). When a number of bandwidth requests are queued in the modems, only a few requests are sent to the CMTS. This occurs due to congestion of sending requests caused by higher number of service flows, greater traffic and small size of packets. Therefore, only a few best effort service flow requests are satisfied by the CMTS.

### PCMM Persistent Gate

Persistent Gate is a feature by which PCMM gate information is maintained for cable modems that go offline. This gate information is quickly enabled after a cable modem returns online. When a cable modem returns online, the Cisco CMTS router scans PCMM gates previously stored, and initiates service to the cable modem according to the respective PCMM gate. This re-enabled service maintains traffic support profiles for that gate, and allocates DOCSIS resources based on the new online subscriber.

### PCMM High Priority Calls

From Cisco IOS XE Amsterdam 17.3.1x release, you can specify the SessionClassID of the PCMM gate that the Cisco cBR has to consider as high priority (911) calls. Previously the Cisco cBR considered a SessionClassID of 0xF as high priority (911) calls.

Use the **packetcable multimedia high-priority priority** command to set SessionClassID of high priority (911) calls. You can use **show cable calls** and **show cable modem calls** to display the ongoing high priority calls.

**Note**

- The default SessionClassID for high priority PCMM calls is 15(0xF).
- Enable **packetcable multimedia** before you use **packetcable multimedia high-priority priority**.
- The Cisco cBR always considers PCMM gates with SessionClassID 15(0xF) as high priority class even after you set a different high priority SessionClassID.

**Example: Configuring a Different SessionClassID for High Priority Calls**

The following example shows how to set the SessionClassID for high priority calls to 7.

```
Router# configure terminal
Router(config)# packetcable multimedia
Router(config)# packetcable multimedia high-priority 7
```

## PCMM Interfaces

PCMM optimizes the IPC handshake between the cable interface line card and the Route Processor (RP) for the Cisco CMTS router. Additional PCMM interface changes from PacketCable 1.x include the handling for COPS interface and distributed cable interface line cards.

### PCMM to COPS Interface

PCMM differs from PacketCable 1.x in handling COPS sessions. The COPS sessions on PCMM use TCP port number 3918 by default. Whereas, PacketCable uses the DQoS specification for TCP port requirements and COPS sessions.

When the PCMM module initializes for the first time, a PCMM registry is added to the cable interface line card and the route processor. The PCMM module also registers the PCMM COPS client with the COPS layer on the Cisco CMTS router.

### PCMM and Distributed Cable Interface Line Cards

As with PacketCable 1.x, PCMM uses IPC messages for voice support. When PCMM gates are created on the Network Processing Engine (NPE) or route processor (RP), the PCMM gate parameters are sent to cable interface line cards. IPC maintains all communication between the NPE or RP, and the cable interface line cards.

Event messaging is used with PCMM to support billing information based on Gate-Set messages. Event messaging for distributed cable interface line cards originates from the line cards, based on the success of DSX operation.

The PCMM module also registers the PCMM COPS client with the COPS layer.

## PCMM Unicast and Multicast

In unicast transmission, content is sent to a unique user. In multicast transmission, content is sent to multiple users simultaneously.

## PCMM Multicast Session Range

You can configure a PCMM multicast session range by specifying IPv4 IP addresses and a mask for a PCMM multicast group. The PCMM multicast session range enables the Cisco CMTS router to accept Gate-Set messages from the PCMM Policy Server. If a PCMM multicast session range is configured, the Cisco CMTS router does not allow you to create multicast sessions using other sources such as Internet Group Management Protocol (IGMP) and DOCSIS Set-Top Gateway (DSG).

## How to Configure PCMM Operations

The following tasks describe how to enable PCMM operations and configure its related features on the Cisco CMTS router:

### Enabling PCMM Operations on the Cisco CMTS Router

To enable PCMM operations on the Cisco CMTS router:

---

**Step 1**    **enable****Example:**

```
Router> enable
```

Enables privileged EXEC mode.

- Enter your password if prompted.

**Step 2**    **configure terminal****Example:**

```
Router# configure terminal
```

Enters global configuration mode.

**Step 3**    **packetcable multimedia****Example:**

```
Router(config)# packetcable multimedia
```

Enables and displays PCMM processing on the Cisco CMTS router. This command enables the Cisco CMTS router to start or stop responding to PCMM COPS messages received from the PCMM Policy Server.

**Step 4**    **packetcable authorize vanilla-docsis-mta****Example:**

```
Router(config)# packetcable authorize vanilla-docsis-mta
```

Allows non-DQoS MTAs to send DOCSIS DSX messages.

**Step 5**    **packetcable gate maxcount *n***

**Example:**

```
Router(config)# packetcable gate maxcount 890
```

Sets the maximum number of PCMM gates in the gate database.

**Step 6** `packetcable timer multimedia T1 timer-value`**Example:**

```
Router(config)# packetcable timer multimedia T1 300000
```

Sets the timeout value for T1 timer used in PCMM gate processing.

**Step 7** `clear packetcable gate counter commit [dqos | multimedia]`**Example:**

```
Router(config)# clear packetcable gate counter commit multimedia
```

(Optional) Clears the specified PCMM gate counter.

**Step 8** `end`**Example:**

```
Router(config)# end
```

Returns to privileged EXEC mode.

---

## Configuring a PCMM Multicast Session Range

A PCMM multicast session range enables the Cisco CMTS router to use a range of IP addresses for a PCMM multicast group.

**Before you begin**

Ensure that PCMM is configured using the **packetcable multimedia command**.

**Note**

- You can configure only one PCMM multicast group on the Cisco CMTS router. You can configure a maximum of ten multicast sessions for a single multicast group.
- The PCMM multicast feature is supported only with the cable modems that are capable of Multicast DSID-based Forwarding (MDF).

**Step 1** `enable`**Example:**

```
Router> enable
```

Enables privileged EXEC mode.

- Enter your password if prompted.

**Step 2**     **configure terminal**

**Example:**

```
Router# configure terminal
```

Enters global configuration mode.

**Step 3**     **cable multicast source pcmm**

**Example:**

```
Router(config)# cable multicast source pcmm
```

Enables PCMM-based multicast service on the Cisco CMTS router and enters multicast session range configuration mode.

**Step 4**     **session-range ip-addressip-mask**

**Example:**

```
Router(config)# session-range 229.0.0.0 255.0.0.0
```

Configures a session range for the PCMM multicast group.

**Step 5**     **end**

**Example:**

```
Router(config)# end
```

Returns to privileged EXEC mode.

---

## Configuration Examples for PacketCable Multimedia

The following sections provide configuration examples for PCMM operations on the Cisco CMTS router:

### Example: Enabling PCMM Operations on the Cisco CMTS Router

```
Router# configure terminal
Router(config)# packetcable multimedia
Router(config)# packetcable authorize vanilla-docsis-mta
Router(config)# packetcable gate maxcount 890
Router(config)# packetcable timer multimedia 30000
```



## Example: Enabling a Multicast Session Range on the Cisco CMTS Router

```
Router# configure terminal
Router(config)# cable multicast source pcmm
Router(config)# session-range 229.0.0.0 255.0.0.0
```

## Verifying PCMM Operations

Use the following **show** commands to verify PCMM operations:

- **show packetcable gate multimedia**
- **show cable multicast db**
- **show interface wideband-cable**
- **show cable multicast qos**

To verify the PCMM multicast gates, use the **show packetcable gate multimedia** command as shown in the following example:

```
Router# show packetcable gate multimedia multicast summary
GateID      i/f          SubscriberID  GC-Addr      State      Type  SFID(us)  SFID(ds)
134         Ca5/0/0      60.1.1.202   2.39.26.19   COMMIT     MM    4          4
Total number of Multimedia-MCAST gates = 1
Total Gates committed(since bootup or clear counter) = 1
```

To verify the PCMM IPv6 gates, use the **show packetcable gate multimedia ipv6** command as shown in the following example:

```
Router# show packetcable gate multimedia ipv6 summary
Load for five secs: 10%/1%; one minute: 9%; five minutes: 9%
Time source is NTP, 03:29:42.153 EST Mon Nov 9 2015

GateID      i/f          SubscriberID  State      SFID(us)  SFID(ds)
409         Ca5/0/2      2001:420:2C7F:FC38:58AF:E36A:80:213A  COMMIT     1326
16789      Ca5/0/2      2001:420:2C7F:FC38:AC40:A49A:F80A:8D0B  COMMIT     1321
33177      Ca5/0/2      2001:420:2C7F:FC38:DD49:72A3:2ECC:8770  COMMIT     1322
49577      Ca5/0/2      2001:420:2C7F:FC38:485:31DF:C88B:E315   COMMIT     1308
65953      Ca5/0/2      2001:420:2C7F:FC38:5AB:AA0B:34AD:ACCF   COMMIT     1336
82337      Ca5/0/2      2001:420:2C7F:FC38:5AB:AA0B:34AD:ACCF   COMMIT     1337
98721      Ca5/0/2      2001:420:2C7F:FC38:5570:EF2E:7565:D36A  COMMIT     1316
115097     Ca5/0/2      2001:420:2C7F:FC38:6009:EF26:F573:7356  COMMIT     1318
131489     Ca5/0/2      2001:420:2C7F:FC38:7D4A:BC50:3FD:CA7    COMMIT     1312
147873     Ca5/0/2      2001:420:2C7F:FC38:E83E:8259:AEF6:5624  COMMIT     1332

Total number of Multimedia gates = 10
Total Gates committed(since bootup or clear counter) = 1024
```

To verify all the PCMM client entries available with the multicast database, use the **show cable multicast db** command as shown in the following example:

```

Router# show cable multicast db client pcmm
Interface : Bundle1
Session (S,G) : (*,229.2.2.12)
Fwd Intf      Bundle Intf  Host Intf  CM MAC      CPE IP      Gate-ID SFID
Wi1/1/0:0     Bundle1           Ca5/0/0    0018.6852.8056 60.1.1.202  134 4

```

To verify multicast sessions on a specific wideband cable interface, use the **show interface wideband-cable** command as shown in the following example:

```

Router# show interface wideband-cable 1/1/0:0 multicast-sessions
Default Multicast Service Flow 3 on Wideband-Cable1/1/0:0
Multicast Group      : 229.2.2.12
  Source              : N/A
  Act GCRs            : 1
  Interface           : Bul
GCR                  : GC  SAID  SFID  Key  GQC  GEn
                    :      512  8196  4    0   512  0
State: A             GI: Bul      RC: 0

```

To verify the attribute-based assignment of service flows on a specific wideband cable interface, use the **show interface wideband-cable** command as shown in the following example:

```

Router# show interface wideband-cable 1/1/0:0
service-flow 4 verbose
Sfid                  : 4
Mac Address           : ffff.ffff.ffff
Type                  : Secondary(Static)
Direction             : Downstream
Current State         : Active
Current QoS Indexes [Prov, Adm, Act] : [4, 4, 4]
Active Time           : 05:26
Required Attributes   : 0x00000000
Forbidden Attributes  : 0x00000000
Aggregate Attributes  : 0x00000000
Multicast Sid         : 8196
Traffic Priority       : 0
Maximum Sustained rate : 0 bits/sec
Maximum Burst         : 3044 bytes
Minimum Reserved Rate : 250000 bits/sec
Minimum Packet Size   : 0 bytes
Maximum Latency       : 0 usecs
Peak Rate             : 0 bits/sec
Admitted QoS Timeout  : 200 seconds
Active QoS Timeout    : 0 seconds
Packets               : 0
Bytes                 : 0
Rate Limit Delayed Packets : 0
Rate Limit Dropped Packets : 0
Current Throughput    : 0 bits/sec, 0 packets/sec
Application Priority   : 0
Low Latency App       : No
Blaze/JIB3 DS Statistic Index : 0
Forwarding Interface  : Wi1/1/0:0
Classifiers: NONE

```

To verify that the PCMM-based MQoS gate controllers are created using the correct session ranges, use the **show cable multicast qos** command as shown in the following example:

```

Router# show cable multicast qos group-qos
Group QoS Index Service Class Control Igmp Limit Override App
DEFAULT mcast_default Aggregate NO-LIMIT
1 SDV_SD Single --- No CLI
512 SDV_HD Single --- No PCMM

```

## High Availability Stateful Switchover (SSO) for PacketCable and PacketCable MultiMedia

Enhanced high availability support enables the synchronization of PacketCable and PacketCable MultiMedia (PCMM) gates during switchover events on the Cisco CMTS router. This enhancement is enabled by default.

This functionality uses the existing per-interface HCCP commands that are used to associate the working and protect interfaces in the case of N+1 redundancy.

## PacketCable and PCMM with Admission Control

A PacketCable or PacketCable Multimedia network contains a number of components that benefit from Admission Control QoS. Admission Control manages and optimizes QoS for PacketCable and PCMM in these ways:

- QoS (based on DOCSIS 1.1 or later versions) for voice and data
- Cable modem registration
- CMS
- Gateway controllers (GC)
- Record keeping servers (RKS)
- Video telephony

When configuring Admission Control with either PacketCable or PCMM, PacketCable or PCMM must be fully operational on the Cisco CMTS headend prior to gaining the benefits from Admission Control.

## Voice MGPI Support

The multiple grants per interval (MGPI) feature enables the Cisco CMTS router to map multiple PacketCable Multimedia gates (application flows) to a single DOCSIS service flow using UGS traffic profiles of the same cable modem. In other words, the Cisco CMTS router increases the number of grants per interval for each application flow based on a single service flow, resulting in multiple grants per interval.

The MGPI feature supports the flow-aggregated voice MGPI functionality based on CableLabs PacketCable Specification (PKT-SP-MM-I05-091029). The flow-aggregated MGPI functionality allows the application manager to use the UGS traffic profile to explicitly set the number of grants per interval and place several application flows on a single gate. This results in an aggregated view for event messages, volume, and time usage limits.

## Voice Support Over DOCSIS 3.0 E-MTAs

PacketCable and PCMM services are supported on embedded multimedia terminal adapters (E-MTAs). An E-MTA is a network element that contains the interface to a physical voice device, a network interface, and all signaling and encapsulation functions required for the VoIP transport, class features signaling, and QoS signaling.

## PacketCable and PCMM Call Trace

To effectively capture signaling information, this functionality buffers signaling for a configured number of PacketCable or PCMM gates. By default, only ten user-configured gate traces are saved in a buffer. After the specified number is reached, any subsequent gate signaling information does not get buffered. When one of the gates being traced is deleted, gate signaling of a new gate is buffered.

Use the **cable dynamic-qos trace** command in global configuration mode to enable the call trace functionality for PacketCable and PacketCable Multimedia gates on the Cisco CMTS router. You will have to specify the number of subscribers for whom call trace needs to be enabled.

## Verifying PacketCable and PCMM Statistics

Use the following commands to verify PacketCable and PCMM statistics on the Cisco CMTS router:

- **show interface cable dynamic-service statistics**
- **show interface cable packetcable statistics**
- **show packetcable cms**

To verify dynamic service statistics based on the cable interface, use the **show interface cable dynamic-service statistics** command as shown in the following example:

```
Router# show interface cable 7/1/0 dynamic-service statistics
  Upstream      Downstream
DSA REQ        0             5
DSA RSP        5             0
DSA ACK        0             5
DSC REQ        0             5
DSC RSP        5             0
DSC ACK        0             5
DSD REQ        0             0
DSD RSP        0             0
Retransmission counts
  Upstream      Downstream
DSA REQ        0             0
DSA RSP        0             0
DSA ACK        0             0
DSC REQ        0             5
DSC RSP        5             0
DSC ACK        0             0
DSD REQ        0             0
DSD RSP        0             0
```

To verify PacketCable IPC statistics based on the cable interface, use the **show interface cable packetcable statistics** command as shown in the following example:

```
Router# show interface cable 7/1/0 packetcable statistics
Packetcable IPC Statistics on RP
Msg  create      gate      gate      gate set  dsd
```

```

        gie      set      del      notify    notify
Sent 0          10      0        0          0
Rcvd 0          0        0        10         0
Packetcable IPC Statistics on LC
Msg  create    gate    gate      gate set   dsd
      gie      set      del      notify    notify
Sent 0          0        0        10         0
Rcvd 0          10      0        0          0

```

To verify all gate controllers that are currently connected to the PacketCable client, use the `show packetcable cms` command as shown in the following example:

```

Router# show packetcable cms
GC-Addr      GC-Port  Client-Addr  COPS-handle  Version  PSID  Key  PDD-Cfg
1.100.30.2   47236    2.39.34.1    0x2FF9E268/1  4.0     0     0     0
2.39.26.19   55390    2.39.34.1    0x2FF9D890/1  1.0     0     0     2

```

To verify all gate controllers including the COPS servers for which the PacketCable connection is gone down, use the `show packetcable cms` command with the `all` keyword as shown in the following example:

```

Router# show packetcable cms all
GC-Addr      GC-Port  Client-Addr  COPS-handle  Version  PSID  Key  PDD-Cfg
1.100.30.2   47236    2.39.34.1    0x2FF9E268/1  4.0     0     0     0
2.39.26.19   55390    2.39.34.1    0x2FF9D890/1  1.0     0     0     2
1.10.30.22   42307    2.39.34.1    0x0           /0       4.0    0     0     0

```

To verify gate controller statistics, use the `show packetcable cms` command with the keyword, `verbose`, as shown in the following example:

```

Router# show packetcable cms verbose
Gate Controller
  Addr      : 1.100.30.2
  Port      : 47236
  Client Addr : 2.39.34.1
  COPS Handle : 0x2FF9E268
  Version    : 4.0
  Statistics :
    gate del = 0 gate del ack = 0 gate del err = 0
    gate info = 0 gate info ack = 0 gate info err = 0
    gate open = 0 gate report state = 0
    gate set = 0 gate set ack = 0 gate set err = 0
    gate alloc = 0 gate alloc ack = 0 gate alloc err = 0
    gate close = 0
Gate Controller
  Addr      : 2.39.26.19
  Port      : 55390
  Client Addr : 2.39.34.1
  COPS Handle : 0x2FF9D890
  Version    : 1.0
  Statistics :
    gate del = 0 gate del ack = 0 gate del err = 0
    gate info = 0 gate info ack = 0 gate info err = 0
    gate open = 0 gate report state = 0
    gate set = 2 gate set ack = 2 gate set err = 0
  PCMM Timers Expired
  Timer T1 = 0 Timer T2 = 0 Timer T3 = 0 Timer T4 = 0
GC-Addr      GC-Port  Client-Addr  COPS-handle  Version  PSID  Key  PDD-Cfg
1.100.30.2   47236    2.39.34.1    0x2FF9E268/1  4.0     0     0     0
2.39.26.19   55390    2.39.34.1    0x2FF9D890/1  1.0     0     0     2

```

# Additional References

## Related Documents

| Related Topic             | Document Title                                                                                                                                                                                                                                                                                                                                          |
|---------------------------|---------------------------------------------------------------------------------------------------------------------------------------------------------------------------------------------------------------------------------------------------------------------------------------------------------------------------------------------------------|
| CMTS commands             | <i>Cisco CMTS Cable Command Reference</i><br><a href="http://www.cisco.com/en/US/docs/ios/cable/command/reference/cbl_book.html">http://www.cisco.com/en/US/docs/ios/cable/command/reference/cbl_book.html</a>                                                                                                                                          |
| N+1 redundancy            | <i>N+1 Redundancy for the Cisco CMTS Routers</i><br><a href="http://www.cisco.com/en/US/docs/ios/cable/configuration/guide/cmts_nplus1_redun_ps2209_TSD_Products_Configuration_Guide_Chapter_00100.html">http://www.cisco.com/en/US/docs/ios/cable/configuration/guide/cmts_nplus1_redun_ps2209_TSD_Products_Configuration_Guide_Chapter_00100.html</a> |
| NTP or SNTP Configuration | To configure the Cisco CMTS router to use Network Time Protocol (NTP) or Simple Network Time Protocol (SNTP), see the “Performing Basic System Management” chapter in the “System Management” section of the <a href="#">Cisco IOS Configuration Guide</a> .                                                                                            |

## Standards

| Standards <sup>5</sup>    | Title                                                                          |
|---------------------------|--------------------------------------------------------------------------------|
| PKT-SP-MM-I06-110629      | PacketCable™ Specification Multimedia Specification                            |
| ITU X.509 V3              | <i>International Telecommunications Union (ITU) X.509 Version 3.0 standard</i> |
| PKT-EM-I03-011221         | <i>PacketCable™ Event Message Specification</i>                                |
| PKT-SP-DQOS-I04-021018    | <i>PacketCable™ Dynamic Quality-of-Service Specification</i>                   |
| PKT-SP-EC-MGCP-I04-011221 | <i>PacketCable™ Network-Based Call Signaling Protocol Specification</i>        |
| PKT-SP-ESP-I01-991229     | <i>PacketCable™ Electronic Surveillance Specification</i>                      |
| PKT-SP-ISTP-I02-011221    | <i>PacketCable™ Internet Signaling Transport Protocol (ISTP) Specification</i> |
| PKT-SP-PROV-I03-011221    | <i>PacketCable™ MTA Device Provisioning Specification</i>                      |

<sup>5</sup> Not all supported standards are listed.

## MIBs

| MIBs                                                  | MIBs Link                                                                                                                                                                                                                   |
|-------------------------------------------------------|-----------------------------------------------------------------------------------------------------------------------------------------------------------------------------------------------------------------------------|
| No new or changed MIBs are supported by this feature. | To locate and download MIBs for selected platforms, Cisco software releases, and feature sets, use Cisco MIB Locator found at the following URL:<br><a href="http://www.cisco.com/go/mibs">http://www.cisco.com/go/mibs</a> |

**RFCs**

| RFCs     | Title                                                      |
|----------|------------------------------------------------------------|
| RFC 1321 | <i>The MD5 Message-Digest Algorithm</i>                    |
| RFC 1510 | <i>The Kerberos Network Authentication Service (V5)</i>    |
| RFC 2138 | <i>Remote Authentication Dial In User Service (RADIUS)</i> |
| RFC 2205 | <i>Resource ReSerVation Protocol (RSVP)</i>                |
| RFC 2327 | <i>SDP: Session Description Protocol</i>                   |
| RFC 2748 | <i>The COPS (Common Open Policy Service) Protocol</i>      |

**Technical Assistance**

| Description                                                                                                                                                                                                                                                                                                                                                                           | Link                                                                                                              |
|---------------------------------------------------------------------------------------------------------------------------------------------------------------------------------------------------------------------------------------------------------------------------------------------------------------------------------------------------------------------------------------|-------------------------------------------------------------------------------------------------------------------|
| The Cisco Support and Documentation website provides online resources to download documentation, software, and tools. Use these resources to install and configure the software and to troubleshoot and resolve technical issues with Cisco products and technologies. Access to most tools on the Cisco Support and Documentation website requires a Cisco.com user ID and password. | <a href="http://www.cisco.com/cisco/web/support/index.html">http://www.cisco.com/cisco/web/support/index.html</a> |

## Feature Information for PacketCable and PacketCable Multimedia

Use Cisco Feature Navigator to find information about the platform support and software image support. Cisco Feature Navigator enables you to determine which software images support a specific software release, feature set, or platform. To access Cisco Feature Navigator, go to the <https://cfng.cisco.com/> link. An account on the Cisco.com page is not required.



**Note** The following table lists the software release in which a given feature is introduced. Unless noted otherwise, subsequent releases of that software release train also support that feature.

| Feature Name                                   | Releases                    | Feature Information                                                                                               |
|------------------------------------------------|-----------------------------|-------------------------------------------------------------------------------------------------------------------|
| PacketCable and PacketCable Multimedia Unicast | Cisco IOS XE Everest 16.6.1 | This feature was integrated into Cisco IOS XE Everest 16.6.1 on the Cisco cBR Series Converged Broadband Routers. |

| Feature Name                                     | Releases                    | Feature Information                                                                                               |
|--------------------------------------------------|-----------------------------|-------------------------------------------------------------------------------------------------------------------|
| PacketCable and PacketCable Multimedia Multicast | Cisco IOS XE Everest 16.6.1 | This feature was integrated into Cisco IOS XE Everest 16.6.1 on the Cisco cBR Series Converged Broadband Routers. |
| DQoS Lite Based IPv6 Voice Support               | Cisco IOS XE Everest 16.6.1 | This feature was integrated into Cisco IOS XE Everest 16.6.1 on the Cisco cBR Series Converged Broadband Routers. |





## CHAPTER 87

# COPS Engine Operation

---

This document describes the Common Open Policy Service (COPS) engine feature on the Cisco CMTS routers. The Cisco CMTS routers also support Access control lists (ACLs) with the COPS engine.

- [Finding Feature Information, on page 1381](#)
- [Hardware Compatibility Matrix for the Cisco cBR Series Routers, on page 1381](#)
- [Prerequisites for the COPS Engine on the Cisco CMTS Routers, on page 1383](#)
- [Restrictions for the COPS Engine on the Cisco CMTS, on page 1383](#)
- [Information About the COPS Engine on the Cisco CMTS, on page 1383](#)
- [How to Configure the COPS Engine on the Cisco CMTS, on page 1383](#)
- [COPS Engine Configuration Examples for Cable, on page 1388](#)
- [Additional References, on page 1389](#)
- [Feature Information for COPS Engine Operation, on page 1390](#)

## Finding Feature Information

Your software release may not support all the features that are documented in this module. For the latest feature information and caveats, see the release notes for your platform and software release. The Feature Information Table at the end of this document provides information about the documented features and lists the releases in which each feature is supported.

Use Cisco Feature Navigator to find information about platform support and Cisco software image support. To access Cisco Feature Navigator, go to <http://tools.cisco.com/ITDIT/CFN/>. An account on <http://www.cisco.com/> is not required.

## Hardware Compatibility Matrix for the Cisco cBR Series Routers



---

**Note** The hardware components that are introduced in a given Cisco IOS-XE Release are supported in all subsequent releases unless otherwise specified.

---

Table 276: Hardware Compatibility Matrix for the Cisco cBR Series Routers

| Cisco CMTS Platform                    | Processor Engine                                                                                                                                                                                  | Interface Cards                                                                                                                                                                                                                                                                                                                                                                                                                                                                                                                                                                                                                                                                                                                                                                                 |
|----------------------------------------|---------------------------------------------------------------------------------------------------------------------------------------------------------------------------------------------------|-------------------------------------------------------------------------------------------------------------------------------------------------------------------------------------------------------------------------------------------------------------------------------------------------------------------------------------------------------------------------------------------------------------------------------------------------------------------------------------------------------------------------------------------------------------------------------------------------------------------------------------------------------------------------------------------------------------------------------------------------------------------------------------------------|
| Cisco cBR-8 Converged Broadband Router | <p><b>Cisco IOS-XE Release 16.5.1 and Later Releases</b></p> <p>Cisco cBR-8 Supervisor:</p> <ul style="list-style-type: none"> <li>• PID—CBR-SUP-250G</li> <li>• PID—CBR-CCAP-SUP-160G</li> </ul> | <p><b>Cisco IOS-XE Release 16.5.1 and Later Releases</b></p> <p>Cisco cBR-8 CCAP Line Cards:</p> <ul style="list-style-type: none"> <li>• PID—CBR-LC-8D30-16U30</li> <li>• PID—CBR-LC-8D31-16U30</li> <li>• PID—CBR-RF-PIC</li> <li>• PID—CBR-RF-PROT-PIC</li> <li>• PID—CBR-CCAP-LC-40G</li> <li>• PID—CBR-CCAP-LC-40G-R</li> <li>• PID—CBR-CCAP-LC-G2-R</li> <li>• PID—CBR-SUP-8X10G-PIC</li> <li>• PID—CBR-2X100G-PIC</li> </ul> <p>Digital PICs:</p> <ul style="list-style-type: none"> <li>• PID—CBR-DPIC-8X10G</li> <li>• PID—CBR-DPIC-2X100G</li> </ul> <p>Cisco cBR-8 Downstream PHY Module:</p> <ul style="list-style-type: none"> <li>• PID—CBR-D31-DS-MOD</li> </ul> <p>Cisco cBR-8 Upstream PHY Modules:</p> <ul style="list-style-type: none"> <li>• PID—CBR-D31-US-MOD</li> </ul> |



**Note** Do not use DPICs (8X10G and 2x100G) to forward IP traffic, as it may cause buffer exhaustion, leading to line card reload.

The only allowed traffic on a DPIC interface is DEPI, UEPI, and GCP traffic from the Cisco cBR-8 router to Remote PHY devices. Other traffic such as DHCP, SSH, and UTSC should flow via another router, since DPICs cannot be used for normal routing.

# Prerequisites for the COPS Engine on the Cisco CMTS Routers

- A compatible policy server must be connected to the network, such as the Cisco COPS QoS Policy Manager.
- Compliance with administrative policy, such as the Computer Assisted Law Enforcement Act (CALEA) or other lawful intercept (LI), is required for use of this feature on the Cisco CMTS routers.

## Restrictions for the COPS Engine on the Cisco CMTS

- Resource Reservation Protocol (RSVP) is not configured on the Cisco CMTS. COPS engine configuration on the Cisco CMTS is limited to networks in which separate RSVP and COPS Servers are configured and operational.

## Information About the COPS Engine on the Cisco CMTS

Common Open Policy Service (COPS) is a protocol for communicating network traffic policy information to network devices.

COPS works in correspondence with the Resource Reservation Protocol (RSVP), which is a means for reserving network resources—primarily bandwidth—to guarantee that applications sending end-to-end across the Internet will perform at the desired speed and quality. RSVP is not configured on the Cisco CMTS, but the Cisco CMTS presumes RSVP on the network for these configurations.

Refer to the [Additional References, on page 1389](#) for further information about COPS for RSVP.

## How to Configure the COPS Engine on the Cisco CMTS

This section describes the tasks for configuring the COPS for RSVP feature on the Cisco CMTS.

To configure the COPS engine on the Cisco CMTS, perform the following tasks:

### Configuring COPS TCP and DSCP Marking

This feature allows you to change the Differentiated Services Code Point (DSCP) marking for COPS messages that are transmitted or received by the Cisco router. The **cops ip dscp** command changes the default IP parameters for connections between the Cisco router and COPS servers in the cable network.

DSCP values are used in Quality of Service (QoS) configurations on a Cisco router to summarize the relationship between DSCP and IP precedence. This command allows COPS to remark the packets for either incoming or outbound connections.

The default setting is 0 for outbound connections. On default incoming connections, the COPS engine takes the DSCP value from the COPS server initiating the TCP connection.



---

**Note** This feature affects all TCP connections with all COPS servers.

---

- For messages transmitted by the Cisco router, the default DSCP value is 0.
- For incoming connections to the Cisco router, the COPS engine takes the DSCP value used by the COPS server that initiates the TCP connection, by default.
- The **cops ip dscp** command allows the Cisco router to re-mark the COPS packets for either incoming or outbound connections.
- This command affects all TCP connections with all COPS servers.
- This command does not affect existing connections to COPS servers. Once you issue this command, this function is supported only for new connections after that point in time.

Perform the following steps to enable optional DSCP marking for COPS messages on the Cisco CMTS.

### Procedure

|               | Command or Action                                                                                                                    | Purpose                                                                                                                                                                                                                                                                                                                                                                                                                                                                                                                                                                                                                                                                                                                                                                                                                                                                                                                                                                                                                                                                                                                                                                                                                        |
|---------------|--------------------------------------------------------------------------------------------------------------------------------------|--------------------------------------------------------------------------------------------------------------------------------------------------------------------------------------------------------------------------------------------------------------------------------------------------------------------------------------------------------------------------------------------------------------------------------------------------------------------------------------------------------------------------------------------------------------------------------------------------------------------------------------------------------------------------------------------------------------------------------------------------------------------------------------------------------------------------------------------------------------------------------------------------------------------------------------------------------------------------------------------------------------------------------------------------------------------------------------------------------------------------------------------------------------------------------------------------------------------------------|
| <b>Step 1</b> | <b>enable</b><br><b>Example:</b><br>Router> <b>enable</b>                                                                            | Enables privileged EXEC mode. <ul style="list-style-type: none"> <li>• Enter your password if prompted.</li> </ul>                                                                                                                                                                                                                                                                                                                                                                                                                                                                                                                                                                                                                                                                                                                                                                                                                                                                                                                                                                                                                                                                                                             |
| <b>Step 2</b> | <b>configure terminal</b><br><b>Example:</b><br>Router# <b>configure terminal</b>                                                    | Enters global configuration mode.                                                                                                                                                                                                                                                                                                                                                                                                                                                                                                                                                                                                                                                                                                                                                                                                                                                                                                                                                                                                                                                                                                                                                                                              |
| <b>Step 3</b> | <b>cops ip dscp [&lt;0-63&gt;   default   af11-af43   cs1-cs7]</b><br><b>Example:</b><br>Router(config)# <b>cops ip dscp default</b> | Specifies the marking for COPS messages that are transmitted by the Cisco router.<br><br>The values for this command specify the markings with which COPS messages are transmitted. The following values are supported for the Cisco CMTS router: <ul style="list-style-type: none"> <li>• <b>0-63</b>—DSCP value ranging from 0-63.</li> <li>• <b>af11</b>—Use AF11 dscp (001010)</li> <li>• <b>af12</b>—Use AF12 dscp (001100)</li> <li>• <b>af13</b>—Use AF13 dscp (001110)</li> <li>• <b>af21</b>—Use AF21 dscp (010010)</li> <li>• <b>af22</b>—Use AF22 dscp (010100)</li> <li>• <b>af23</b>—Use AF23 dscp (010110)</li> <li>• <b>af31</b>—Use AF31 dscp (011010)</li> <li>• <b>af32</b>—Use AF32 dscp (011100)</li> <li>• <b>af33</b>—Use AF33 dscp (011110)</li> <li>• <b>af41</b>—Use AF41 dscp (100010)</li> <li>• <b>af42</b>—Use AF42 dscp (100100)</li> <li>• <b>af43</b>—Use AF43 dscp (100110)</li> <li>• <b>cs1</b>—Use CS1 dscp (001000) [precedence 1]</li> <li>• <b>cs2</b>—Use CS2 dscp (010000) [precedence 2]</li> <li>• <b>cs3</b>—Use CS3 dscp (011000) [precedence 3]</li> <li>• <b>cs4</b>—Use CS4 dscp (100000) [precedence 4]</li> <li>• <b>cs5</b>—Use CS5 dscp (101000) [precedence 5]</li> </ul> |

|               | Command or Action                                                          | Purpose                                                                                                                                                                                                                                                      |
|---------------|----------------------------------------------------------------------------|--------------------------------------------------------------------------------------------------------------------------------------------------------------------------------------------------------------------------------------------------------------|
|               |                                                                            | <ul style="list-style-type: none"> <li>• <b>cs6</b>—Use CS6 dscp (110000) [precedence 6]</li> <li>• <b>cs7</b>—Use CS7 dscp (111000) [precedence 7]</li> <li>• <b>default</b>—Use default dscp (000000)</li> <li>• <b>ef</b>—Use EF dscp (101110)</li> </ul> |
| <b>Step 4</b> | exit<br><br><b>Example:</b><br><br><pre>Router(config)# exit Router#</pre> | Returns to privileged EXEC mode.                                                                                                                                                                                                                             |

## Configuring COPS TCP Window Size

This feature allows you to override the default TCP receive window size that is used by COPS processes. This setting can be used to prevent the COPS server from sending too much data at one time.

Perform the following steps to change the TCP Window size on the Cisco CMTS.

### Procedure

|               | Command or Action                                                                                                     | Purpose                                                                                                                                                                                                                                                                                                                                                                                                                                                                                                                   |
|---------------|-----------------------------------------------------------------------------------------------------------------------|---------------------------------------------------------------------------------------------------------------------------------------------------------------------------------------------------------------------------------------------------------------------------------------------------------------------------------------------------------------------------------------------------------------------------------------------------------------------------------------------------------------------------|
| <b>Step 1</b> | enable<br><br><b>Example:</b><br><br><pre>Router&gt; enable</pre>                                                     | Enables privileged EXEC mode. <ul style="list-style-type: none"> <li>• Enter your password if prompted.</li> </ul>                                                                                                                                                                                                                                                                                                                                                                                                        |
| <b>Step 2</b> | configure terminal<br><br><b>Example:</b><br><br><pre>Router# configure terminal</pre>                                | Enters global configuration mode.                                                                                                                                                                                                                                                                                                                                                                                                                                                                                         |
| <b>Step 3</b> | cops tcp window-size <i>bytes</i><br><br><b>Example:</b><br><br><pre>Router(config)# cops tcp window-size 64000</pre> | Overrides the default TCP receive window size on the Cisco CMTS. To return the TCP window size to a default setting of 4K, use the <b>no</b> form of this command. <p><b>Note</b> The default COPS TCP window size is 4000 bytes.</p> <p><b>Note</b> This command does not affect existing connections to COPS servers. Once you issue this command, this function is supported only for new connections after that point in time.</p> <p><b>Note</b> This command affects all TCP connections with all COPS servers.</p> |
| <b>Step 4</b> | exit<br><br><b>Example:</b>                                                                                           | Returns to privileged EXEC mode.                                                                                                                                                                                                                                                                                                                                                                                                                                                                                          |

|  | Command or Action                        | Purpose |
|--|------------------------------------------|---------|
|  | Router (config) # <b>exit</b><br>Router# |         |

## Configuring Access Control List Support for COPS Engine

Perform the following steps to configure COPS ACLs on the Cisco CMTS.

### Procedure

|               | Command or Action                                                                                                                         | Purpose                                                                                                                                                                                                |
|---------------|-------------------------------------------------------------------------------------------------------------------------------------------|--------------------------------------------------------------------------------------------------------------------------------------------------------------------------------------------------------|
| <b>Step 1</b> | <b>enable</b><br><b>Example:</b><br>Router> <b>enable</b>                                                                                 | Enables privileged EXEC mode.<br><ul style="list-style-type: none"><li>• Enter your password if prompted.</li></ul>                                                                                    |
| <b>Step 2</b> | <b>configure terminal</b><br><b>Example:</b><br>Router# <b>configure terminal</b>                                                         | Enters global configuration mode.                                                                                                                                                                      |
| <b>Step 3</b> | <b>cops listeners access-list</b> { <i>acl-num</i>   <i>acl-name</i> }<br><b>Example:</b><br>Router# <b>cops listeners access-list 40</b> | Configures access control lists (ACLs) for inbound connections to all COPS listener applications on the Cisco CMTS. To remove this setting from the Cisco CMTS, us the <b>no</b> form of this command. |
| <b>Step 4</b> | <b>exit</b><br><b>Example:</b><br>Router (config) # <b>exit</b><br>Router#                                                                | Returns to privileged EXEC mode.                                                                                                                                                                       |

### What to do next

Access lists can be displayed by using the **show access-list** command in privileged EXEC mode.

## Restricting RSVP Policy to Specific Access Control Lists

Perform the following steps to restrict the RSVP policy to specific ACLs, as already configured on the Cisco CMTS.

For ACL configuration, refer to the [Configuring Access Control List Support for COPS Engine, on page 1386](#).

## Procedure

|               | Command or Action                                                                                                                                                                                  | Purpose                                                                                                                                       |
|---------------|----------------------------------------------------------------------------------------------------------------------------------------------------------------------------------------------------|-----------------------------------------------------------------------------------------------------------------------------------------------|
| <b>Step 1</b> | <b>enable</b><br><b>Example:</b><br>Router> <b>enable</b>                                                                                                                                          | Enables privileged EXEC mode.<br>Enter your password if prompted.                                                                             |
| <b>Step 2</b> | <b>configure terminal</b><br><b>Example:</b><br>Router# <b>configure terminal</b>                                                                                                                  | Enters global configuration mode.                                                                                                             |
| <b>Step 3</b> | <b>interface cable</b> ( <i>slot /subslot /port</i> )<br><b>Example:</b><br>Router (config)# <b>interface cable</b> 8/0/1<br>Router (config-if) #                                                  | Enters interface configuration mode.                                                                                                          |
| <b>Step 4</b> | <b>ip rsvp policy cops</b> <i>ACL-1 ACL-2 servers iP-addr1 IP-addr2</i><br><b>Example:</b><br>Router (config-if) # <b>ip rsvp policy cops</b> 40 160<br><b>servers</b> 161.44.130.164 161.44.129.2 | Tells the router to apply RSVP policy to messages that match the specified ACLs, and specifies the COPS server or servers for those sessions. |
| <b>Step 5</b> | <b>exit</b><br><b>Example:</b><br>Router (config) # <b>exit</b><br>Router#                                                                                                                         | Returns to privileged EXEC mode.                                                                                                              |

## Displaying and Verifying COPS Engine Configuration on the Cisco CMTS

Once COPS is enabled and configured on the Cisco CMTS, you can verify and track configuration by using one or all of the **show** commands in the following steps.

## Procedure

|               | Command or Action                                                               | Purpose                                                                            |
|---------------|---------------------------------------------------------------------------------|------------------------------------------------------------------------------------|
| <b>Step 1</b> | <b>enable</b><br><b>Example:</b><br>Router> <b>enable</b>                       | Enables privileged EXEC mode.<br>Enter your password if prompted.                  |
| <b>Step 2</b> | <b>show cops servers</b><br><b>Example:</b><br>Router# <b>show cops servers</b> | Displays server addresses, port, state, keepalives, and policy client information. |

|               | Command or Action                                                                             | Purpose                                                                         |
|---------------|-----------------------------------------------------------------------------------------------|---------------------------------------------------------------------------------|
| <b>Step 3</b> | <b>show ip rsvp policy cops</b><br><b>Example:</b><br>Router# <b>show ip rsvp policy cops</b> | Displays policy server addresses, ACL IDs, and client/server connection status. |
| <b>Step 4</b> | <b>show ip rsvp policy</b><br><b>Example:</b><br>Router# <b>show ip rsvp policy</b>           | Displays ACL IDs and their connection status.                                   |

## Show Commands for COPS Engine Information

The following examples display three views of the COPS engine configuration on the Cisco router. These respective show commands verify the COPS engine configuration.

### Displaying COPS Servers on the Network

This example displays the policy server address, state, keepalives, and policy client information:

```
Router# show cops servers
COPS SERVER: Address: 161.44.135.172. Port: 3288. State: 0. Keepalive: 120 sec
Number of clients: 1. Number of sessions: 1.
COPS CLIENT: Client type: 1. State: 0.
```

### Displaying COPS Policy Information on the Network

This example displays the policy server address, the ACL ID, and the client/server connection status:

```
Router# show ip rsvp policy cops
COPS/RSVP entry. ACLs: 40 60
PDPs: 161.44.135.172
Current state: Connected
Currently connected to PDP 161.44.135.172, port 0
```

### Displaying Access Lists for COPS

This example displays the ACL ID numbers and the status for each ACL ID:

```
Router# show ip rsvp policy
Local policy: Currently unsupported
COPS:
ACLs: 40 60 . State: CONNECTED.
ACLs: 40 160 . State: CONNECTING.
```

## COPS Engine Configuration Examples for Cable

The following sections provide COPS for RSVP configuration examples on the Cisco CMTS:



## Example: COPS Server Specified

The following example specifies the COPS server and enables COPS for RSVP on the server. Both of these functions are accomplished by using the **ip rsvp policy cops** command. By implication, the default settings for all remaining COPS for RSVP commands are accepted.

```
Router# configure terminal
Enter configuration commands, one per line. End with CNTL/Z.
Router(config)# ip rsvp policy cops servers 161.44.130.168 161.44.129.6
Router(config)# exit
```

## Example: COPS Server Display

The following examples display three views of the COPS for RSVP configuration on the router, which can be used to verify the COPS for RSVP configuration.

This example displays the policy server address, state, keepalives, and policy client information:

```
Router# show cops servers
COPS SERVER: Address: 161.44.135.172. Port: 3288. State: 0. Keepalive: 120 sec
Number of clients: 1. Number of sessions: 1.
    COPS CLIENT: Client type: 1. State: 0.
```

This example displays the policy server address, the ACL ID, and the client/server connection status:

```
Router# show ip rsvp policy cops
COPS/RSVP entry. ACLs: 40 60
PDPs: 161.44.135.172
Current state: Connected
Currently connected to PDP 161.44.135.172, port 0
```

This example displays the ACL ID numbers and the status for each ACL ID:

```
Router# show ip rsvp policy
Local policy: Currently unsupported
COPS:
ACLs: 40 60 . State: CONNECTED.
ACLs: 40 160 . State: CONNECTING.
```

## Additional References

### Related Documents

| Related Topic       | Document Title                                                                                                                                                                                                                                                                                                                                                                                                                                                                                                                   |
|---------------------|----------------------------------------------------------------------------------------------------------------------------------------------------------------------------------------------------------------------------------------------------------------------------------------------------------------------------------------------------------------------------------------------------------------------------------------------------------------------------------------------------------------------------------|
| Cisco CMTS Commands | <a href="#">Cisco CMTS Cable Command Reference</a>                                                                                                                                                                                                                                                                                                                                                                                                                                                                               |
| COPS for RSVP       | <ul style="list-style-type: none"> <li>• <a href="#">Configuring COPS for RSVP</a></li> <li>• <a href="http://www.cisco.com/en/US/docs/ios-xml/ios/qos_rsvp/configuration/12-4t/cops_rsvp.htm">http://www.cisco.com/en/US/docs/ios-xml/ios/qos_rsvp/configuration/12-4t/cops_rsvp.htm</a></li> <li>• <a href="#">COPS for RSVP</a></li> <li>• <a href="http://www.cisco.com/en/US/docs/ios/12_1t/12_1t1/feature/guide/CopsRSVP.html">http://www.cisco.com/en/US/docs/ios/12_1t/12_1t1/feature/guide/CopsRSVP.html</a></li> </ul> |

**Standards**

| Standard              | Title                                                                                                                      |
|-----------------------|----------------------------------------------------------------------------------------------------------------------------|
| PKT-SP-ESP-I01-991229 | PacketCable™ Electronic Surveillance Specification ( <a href="http://www.packetcable.com">http://www.packetcable.com</a> ) |

**MIBs**

| MIB                                                                                                                     | MIBs Link                                                                                                                                                                                                                  |
|-------------------------------------------------------------------------------------------------------------------------|----------------------------------------------------------------------------------------------------------------------------------------------------------------------------------------------------------------------------|
| <ul style="list-style-type: none"> <li>No MIBs have been introduced or enhanced for support of this feature.</li> </ul> | To locate and download MIBs for selected platforms, Cisco IOS releases, and feature sets, use Cisco MIB Locator found at the following URL:<br><br><a href="http://www.cisco.com/go/mibs">http://www.cisco.com/go/mibs</a> |

**RFCs**

| RFC                   | Title                                                                                                                                                                                                                                                                                                                                                                                                                                                    |
|-----------------------|----------------------------------------------------------------------------------------------------------------------------------------------------------------------------------------------------------------------------------------------------------------------------------------------------------------------------------------------------------------------------------------------------------------------------------------------------------|
| General RFC Resources | <ul style="list-style-type: none"> <li><i>RFC Index Search Engine</i><br/><a href="http://www.rfc-editor.org/rfcsearch.html">http://www.rfc-editor.org/rfcsearch.html</a></li> <li><i>SNMP: Frequently Asked Questions About MIB RFCs</i><br/><a href="http://www.cisco.com/en/US/tech/tk648/tk362/technologies_q_and_a_item09186a00800c2612...">http://www.cisco.com/en/US/tech/tk648/tk362/technologies_q_and_a_item09186a00800c2612...</a></li> </ul> |

**Technical Assistance**

| Description                                                                                                                                                                                                                                                                         | Link                                                                            |
|-------------------------------------------------------------------------------------------------------------------------------------------------------------------------------------------------------------------------------------------------------------------------------------|---------------------------------------------------------------------------------|
| The Cisco Technical Support & Documentation website contains thousands of pages of searchable technical content, including links to products, technologies, solutions, technical tips, and tools. Registered Cisco.com users can log in from this page to access even more content. | <a href="http://www.cisco.com/techsupport">http://www.cisco.com/techsupport</a> |

## Feature Information for COPS Engine Operation

Use Cisco Feature Navigator to find information about the platform support and software image support. Cisco Feature Navigator enables you to determine which software images support a specific software release, feature set, or platform. To access Cisco Feature Navigator, go to the <https://cfnng.cisco.com/> link. An account on the Cisco.com page is not required.



**Note** The following table lists the software release in which a given feature is introduced. Unless noted otherwise, subsequent releases of that software release train also support that feature.

*Table 277: Feature Information for COPS Engine Operation*

| <b>Feature Name</b>   | <b>Releases</b>             | <b>Feature Information</b>                                                                                        |
|-----------------------|-----------------------------|-------------------------------------------------------------------------------------------------------------------|
| COPS Engine Operation | Cisco IOS XE Everest 16.6.1 | This feature was integrated into Cisco IOS XE Everest 16.6.1 on the Cisco cBR Series Converged Broadband Routers. |





## PART **XI**

# Quality of Services Configuration

- [Dynamic Bandwidth Sharing, on page 1395](#)
- [Modular Quality of Service Command-Line Interface QoS, on page 1403](#)
- [DOCSIS 1.1 for the Cisco CMTS Routers, on page 1423](#)
- [Default DOCSIS 1.0 ToS Overwrite, on page 1463](#)
- [DOCSIS WFQ Scheduler on the Cisco CMTS Routers, on page 1469](#)
- [Fairness Across DOCSIS Interfaces, on page 1479](#)
- [Service Group Admission Control, on page 1493](#)
- [Subscriber Traffic Management, on page 1507](#)
- [Narrowband Digital Forward And Narrowband Digital Return, on page 1535](#)
- [Differentiated Services Code Point Downstream, on page 1547](#)





## CHAPTER 88

# Dynamic Bandwidth Sharing

---

The Cisco cBR series router enables dynamic bandwidth sharing (DBS) on integrated cable (IC) and wideband (WB) cable interfaces.

Your software release may not support all the features that are documented in this module. For the latest feature information and caveats, see the release notes for your platform and software release. The Feature Information Table at the end of this document provides information about the documented features and lists the releases in which each feature is supported.

Use Cisco Feature Navigator to find information about platform support and Cisco software image support. To access Cisco Feature Navigator, go to <http://tools.cisco.com/ITDIT/CFN/>. An account on <http://www.cisco.com/> is not required.

### Contents

- [Hardware Compatibility Matrix for the Cisco cBR Series Routers, on page 1395](#)
- [Information About Dynamic Bandwidth Sharing, on page 1397](#)
- [How to Configure Dynamic Bandwidth Sharing, on page 1397](#)
- [Verifying the Dynamic Bandwidth Sharing Configuration, on page 1398](#)
- [Additional References, on page 1401](#)
- [Feature Information for Dynamic Bandwidth Sharing, on page 1402](#)

## Hardware Compatibility Matrix for the Cisco cBR Series Routers



---

**Note** The hardware components that are introduced in a given Cisco IOS-XE Release are supported in all subsequent releases unless otherwise specified.

---

Table 278: Hardware Compatibility Matrix for the Cisco cBR Series Routers

| Cisco CMTS Platform                    | Processor Engine                                                                                                                                                                                  | Interface Cards                                                                                                                                                                                                                                                                                                                                                                                                                                                                                                                                                                                                                                                                                                                                                                                 |
|----------------------------------------|---------------------------------------------------------------------------------------------------------------------------------------------------------------------------------------------------|-------------------------------------------------------------------------------------------------------------------------------------------------------------------------------------------------------------------------------------------------------------------------------------------------------------------------------------------------------------------------------------------------------------------------------------------------------------------------------------------------------------------------------------------------------------------------------------------------------------------------------------------------------------------------------------------------------------------------------------------------------------------------------------------------|
| Cisco cBR-8 Converged Broadband Router | <p><b>Cisco IOS-XE Release 16.5.1 and Later Releases</b></p> <p>Cisco cBR-8 Supervisor:</p> <ul style="list-style-type: none"> <li>• PID—CBR-SUP-250G</li> <li>• PID—CBR-CCAP-SUP-160G</li> </ul> | <p><b>Cisco IOS-XE Release 16.5.1 and Later Releases</b></p> <p>Cisco cBR-8 CCAP Line Cards:</p> <ul style="list-style-type: none"> <li>• PID—CBR-LC-8D30-16U30</li> <li>• PID—CBR-LC-8D31-16U30</li> <li>• PID—CBR-RF-PIC</li> <li>• PID—CBR-RF-PROT-PIC</li> <li>• PID—CBR-CCAP-LC-40G</li> <li>• PID—CBR-CCAP-LC-40G-R</li> <li>• PID—CBR-CCAP-LC-G2-R</li> <li>• PID—CBR-SUP-8X10G-PIC</li> <li>• PID—CBR-2X100G-PIC</li> </ul> <p>Digital PICs:</p> <ul style="list-style-type: none"> <li>• PID—CBR-DPIC-8X10G</li> <li>• PID—CBR-DPIC-2X100G</li> </ul> <p>Cisco cBR-8 Downstream PHY Module:</p> <ul style="list-style-type: none"> <li>• PID—CBR-D31-DS-MOD</li> </ul> <p>Cisco cBR-8 Upstream PHY Modules:</p> <ul style="list-style-type: none"> <li>• PID—CBR-D31-US-MOD</li> </ul> |



**Note** Do not use DPICs (8X10G and 2x100G) to forward IP traffic, as it may cause buffer exhaustion, leading to line card reload.

The only allowed traffic on a DPIC interface is DEPI, UEPI, and GCP traffic from the Cisco cBR-8 router to Remote PHY devices. Other traffic such as DHCP, SSH, and UTSC should flow via another router, since DPICs cannot be used for normal routing.



# Information About Dynamic Bandwidth Sharing

## DBS for Integrated and Wideband Cable Interfaces

Prior to DOCSIS 3.0 standards, cable service flows were associated with a single cable interface, which in turn corresponded to a physical downstream on a line card. Under DOCSIS 3.0 standards, cable service flows can be associated with more than one downstream channel.

DBS is the dynamic allocation of bandwidth for IC and WB cable interfaces sharing the same downstream channel. The bandwidth available to each IC, WB cable, or narrowband channel is not a fixed value—it depends on the configuration and the traffic load on the IC or WB cable.

DBS enables high burst rates with DOCSIS 2.0 cable modems as well as DOCSIS 3.0 cable modems. The DBS feature continues working across line card and Supervisor switchovers with no loss of functionality.

## How to Configure Dynamic Bandwidth Sharing

Dynamic bandwidth sharing is enabled by default on the integrated and wideband cable interfaces on the Cisco cBR router. You can configure the bandwidth allocation for the WB and IC interfaces.



**Important** Dynamic bandwidth sharing cannot be disabled on the Cisco cBR router.

This section contains the following procedures:

### Configuring DBS for a Wideband Cable Interface

Perform the following to configure the bandwidth allocation for a wideband cable interface.

#### Procedure

|        | Command or Action                                                                              | Purpose                                                                                                            |
|--------|------------------------------------------------------------------------------------------------|--------------------------------------------------------------------------------------------------------------------|
| Step 1 | <b>enable</b><br><b>Example:</b><br>Router> enable                                             | Enables privileged EXEC mode. <ul style="list-style-type: none"> <li>• Enter your password if prompted.</li> </ul> |
| Step 2 | <b>configure terminal</b><br><b>Example:</b><br>Router# configure terminal                     | Enters global configuration mode.                                                                                  |
| Step 3 | <b>interface wideband-cable</b><br><i>slot/subslot/portwideband-channel</i><br><b>Example:</b> | Configures a wideband cable interface.                                                                             |

|               | Command or Action                                                                                                                                                                                                                     | Purpose                                                                 |
|---------------|---------------------------------------------------------------------------------------------------------------------------------------------------------------------------------------------------------------------------------------|-------------------------------------------------------------------------|
|               | Router(config)# <b>interface</b> <b>wideband-cable</b> 1/0/0:0                                                                                                                                                                        |                                                                         |
| <b>Step 4</b> | <b>cable rf-channel channel-list</b> <i>grouplist</i><br><b>[bandwidth-percent</b> <i>bw-percent</i> <b>]</b><br><br><b>Example:</b><br><br>Router(config-if)# <b>cable rf-channel channel-list</b><br><b>10 bandwidth-percent 50</b> | Configures the bandwidth allocation for the wideband channel interface. |

## Configuring DBS for an Integrated Cable Interface

Perform this procedure to configure the bandwidth allocation for an integrated cable interface.

### Procedure

|               | Command or Action                                                                                                                                            | Purpose                                                                                                            |
|---------------|--------------------------------------------------------------------------------------------------------------------------------------------------------------|--------------------------------------------------------------------------------------------------------------------|
| <b>Step 1</b> | <b>enable</b><br><br><b>Example:</b><br><br>Router> <b>enable</b>                                                                                            | Enables privileged EXEC mode. <ul style="list-style-type: none"> <li>• Enter your password if prompted.</li> </ul> |
| <b>Step 2</b> | <b>configure terminal</b><br><br><b>Example:</b><br><br>Router# <b>configure terminal</b>                                                                    | Enters global configuration mode.                                                                                  |
| <b>Step 3</b> | <b>interface integrated-cable</b> <i>slot/subslot/portrf-channel</i><br><br><b>Example:</b><br><br>Router(config)# <b>interface integrated-cable</b> 1/0/0:0 | Enters the cable interface mode.                                                                                   |
| <b>Step 4</b> | <b>cable rf-bandwidth-percent</b> <i>bw-percent</i><br><br><b>Example:</b><br><br>Router(config-if)# <b>cable rf-bandwidth-percent</b> 50                    | Configures the bandwidth allocation for the integrated cable interface.                                            |

## Verifying the Dynamic Bandwidth Sharing Configuration

Use the following commands to verify the dynamic bandwidth sharing information:

- **show controllers Integrated-Cable** *slot/subslot/port* **bandwidth rf-channel**—Displays the bandwidth information for RF channels.

Following is a sample output of the command:

```
Router# show controllers integrated-Cable 2/0/0 bandwidth rf-channel
```

| Ctrlr | RF | IF         | CIR (Kbps) | Guar (Kbps) |
|-------|----|------------|------------|-------------|
| 2/0/0 | 0  | In2/0/0:0  | 7500       | 13750       |
|       |    | Wi2/0/0:0  | 7500       | 13750       |
|       |    | Wi2/0/0:1  | 3750       | 10000       |
| 2/0/0 | 1  | In2/0/0:1  | 7500       | 13750       |
|       |    | Wi2/0/0:0  | 7500       | 13750       |
|       |    | Wi2/0/0:1  | 3750       | 10000       |
| 2/0/0 | 2  | In2/0/0:2  | 7500       | 12500       |
|       |    | Wi2/0/0:0  | 7500       | 12500       |
|       |    | Wi2/0/0:1  | 7500       | 12500       |
| 2/0/0 | 3  | In2/0/0:3  | 7500       | 12500       |
|       |    | Wi2/0/0:0  | 7500       | 12500       |
|       |    | Wi2/0/0:1  | 7500       | 12500       |
| 2/0/0 | 4  | In2/0/0:4  | 7500       | 12500       |
|       |    | Wi2/0/0:0  | 7500       | 12500       |
|       |    | Wi2/0/0:1  | 7500       | 12500       |
| 2/0/0 | 5  | In2/0/0:5  | 7500       | 12500       |
|       |    | Wi2/0/0:0  | 7500       | 12500       |
|       |    | Wi2/0/0:1  | 7500       | 12500       |
| 2/0/0 | 6  | In2/0/0:6  | 7500       | 12500       |
|       |    | Wi2/0/0:0  | 7500       | 12500       |
|       |    | Wi2/0/0:1  | 7500       | 12500       |
| 2/0/0 | 7  | In2/0/0:7  | 7500       | 12500       |
|       |    | Wi2/0/0:0  | 7500       | 12500       |
|       |    | Wi2/0/0:1  | 7500       | 12500       |
| 2/0/0 | 8  | In2/0/0:8  | 7500       | 18750       |
|       |    | Wi2/0/0:1  | 7500       | 18750       |
|       |    | Wi2/0/0:2  | 7500       | 0           |
| 2/0/0 | 9  | In2/0/0:9  | 7500       | 18750       |
|       |    | Wi2/0/0:1  | 7500       | 18750       |
|       |    | Wi2/0/0:2  | 7500       | 0           |
| 2/0/0 | 10 | In2/0/0:10 | 7500       | 18750       |
|       |    | Wi2/0/0:1  | 7500       | 18750       |
|       |    | Wi2/0/0:2  | 7500       | 0           |
| 2/0/0 | 11 | In2/0/0:11 | 7500       | 18750       |
|       |    | Wi2/0/0:1  | 7500       | 18750       |
|       |    | Wi2/0/0:2  | 7500       | 0           |
| 2/0/0 | 12 | In2/0/0:12 | 7500       | 37500       |
|       |    | Wi2/0/0:2  | 7500       | 0           |
|       |    | Wi2/0/0:3  | 7500       | 0           |
| 2/0/0 | 13 | In2/0/0:13 | 7500       | 37500       |
|       |    | Wi2/0/0:2  | 7500       | 0           |
|       |    | Wi2/0/0:3  | 7500       | 0           |

- **show controllers Integrated-Cable slot/subslot/port bandwidth wb-channel**—Displays the bandwidth information for wideband channels.

Following is a sample output of the command:

```
Router# show controllers Integrated-Cable 2/0/0 bandwidth wb-channel
```

| Ctrlr | WB | RF      | CIR (Kbps) | Guar (Kbps) |
|-------|----|---------|------------|-------------|
| 2/0/0 | 0  |         | 60000      | 102500      |
|       |    | 2/0/0:0 | 7500       | 13750       |
|       |    | 2/0/0:1 | 7500       | 13750       |
|       |    | 2/0/0:2 | 7500       | 12500       |
|       |    | 2/0/0:3 | 7500       | 12500       |
|       |    | 2/0/0:4 | 7500       | 12500       |
|       |    | 2/0/0:5 | 7500       | 12500       |
|       |    | 2/0/0:6 | 7500       | 12500       |
|       |    | 2/0/0:7 | 7500       | 12500       |

```

2/0/0    1
          2/0/0:0  3750    10000
          2/0/0:1  3750    10000
          2/0/0:2  7500    12500
          2/0/0:3  7500    12500
          2/0/0:4  7500    12500
          2/0/0:5  7500    12500
          2/0/0:6  7500    12500
          2/0/0:7  7500    12500
          2/0/0:8  7500    18750
          2/0/0:9  7500    18750
          2/0/0:10 7500    18750
          2/0/0:11 7500    18750
          2/0/0:32  0         0
          2/0/0:33  0         0
          2/0/0:34  0         0
          2/0/0:35  0         0
2/0/0    2
          2/0/0:8  7500     0
          2/0/0:9  7500     0
          2/0/0:10 7500     0
          2/0/0:11 7500     0
          2/0/0:12 7500     0
          2/0/0:13 7500     0
          2/0/0:14 7500     0
          2/0/0:15 7500     0
          2/0/0:64  0         0
          2/0/0:65  0         0
          2/0/0:66  0         0
          2/0/0:67  0         0

```

- **show controllers Integrated-Cable slot/subslot/port mapping rf-channel**—Displays the mapping for RF channels.

Following is a sample output of the command:

```
Router# show controllers integrated-cable 2/0/0 mapping rf-channel
```

| Ctrlr | RF | IC % | IC Rem | WB      | WB % | WB Rem |
|-------|----|------|--------|---------|------|--------|
| 2/0/0 | 0  | 20   | 1      | 2/0/0:0 | 20   | 1      |
|       |    |      |        | 2/0/0:1 | 10   | 1      |
| 2/0/0 | 1  | 20   | 1      | 2/0/0:0 | 20   | 1      |
|       |    |      |        | 2/0/0:1 | 10   | 1      |
| 2/0/0 | 2  | 20   | 1      | 2/0/0:0 | 20   | 1      |
|       |    |      |        | 2/0/0:1 | 20   | 1      |
| 2/0/0 | 3  | 20   | 1      | 2/0/0:0 | 20   | 1      |
|       |    |      |        | 2/0/0:1 | 20   | 1      |
| 2/0/0 | 4  | 20   | 1      | 2/0/0:0 | 20   | 1      |
|       |    |      |        | 2/0/0:1 | 20   | 1      |
| 2/0/0 | 5  | 20   | 1      | 2/0/0:0 | 20   | 1      |
|       |    |      |        | 2/0/0:1 | 20   | 1      |
| 2/0/0 | 6  | 20   | 1      | 2/0/0:0 | 20   | 1      |
|       |    |      |        | 2/0/0:1 | 20   | 1      |
| 2/0/0 | 7  | 20   | 1      | 2/0/0:0 | 20   | 1      |
|       |    |      |        | 2/0/0:1 | 20   | 1      |
| 2/0/0 | 8  | 20   | 1      | 2/0/0:1 | 20   | 1      |
|       |    |      |        | 2/0/0:2 | 20   | 1      |
| 2/0/0 | 9  | 20   | 1      | 2/0/0:1 | 20   | 1      |
|       |    |      |        | 2/0/0:2 | 20   | 1      |
| 2/0/0 | 10 | 20   | 1      | 2/0/0:1 | 20   | 1      |
|       |    |      |        | 2/0/0:2 | 20   | 1      |

- **show controllers Integrated-Cable slot/port/interface-number mapping wb-channel**—Displays the mapping for wideband channels.

Following is a sample output of the command:

```
Router# show controllers integrated-Cable 2/0/0 mapping wb-channel
```

```

Ctrlr   WB      RF          WB %   WB Rem
2/0/0   0       2/0/0:0     20    1
        2/0/0:1     20    1
        2/0/0:2     20    1
        2/0/0:3     20    1
        2/0/0:4     20    1
        2/0/0:5     20    1
        2/0/0:6     20    1
        2/0/0:7     20    1
2/0/0   1       2/0/0:0     10    1
        2/0/0:1     10    1
        2/0/0:2     20    1
        2/0/0:3     20    1
        2/0/0:4     20    1
        2/0/0:5     20    1
        2/0/0:6     20    1
        2/0/0:7     20    1
        2/0/0:8     20    1
        2/0/0:9     20    1
        2/0/0:10    20    1
        2/0/0:11    20    1
        2/0/0:32    20    1
        2/0/0:33    20    1
        2/0/0:34    20    1
        2/0/0:35    20    1
2/0/0   2       2/0/0:8     20    1
        2/0/0:9     20    1
        2/0/0:10    20    1
        2/0/0:11    20    1
        2/0/0:12    20    1
        2/0/0:13    20    1
        2/0/0:14    20    1
        2/0/0:15    20    1
        2/0/0:64    20    1
        2/0/0:65    20    1
        2/0/0:66    20    1
        2/0/0:67    20    1
2/0/0   3       2/0/0:12    20    1
        2/0/0:13    20    1
        2/0/0:14    20    1
        2/0/0:15    20    1
        2/0/0:16    20    1
        2/0/0:17    20    1

```

## Additional References

### Related Documents

| Related Topic             | Document Title                            |
|---------------------------|-------------------------------------------|
| Cisco CMTS cable commands | <i>Cisco CMTS Cable Command Reference</i> |

**Technical Assistance**

| Description                                                                                                                                                                                                                                                                                                                                                                                                                                                                                                                                                             | Link                                                                    |
|-------------------------------------------------------------------------------------------------------------------------------------------------------------------------------------------------------------------------------------------------------------------------------------------------------------------------------------------------------------------------------------------------------------------------------------------------------------------------------------------------------------------------------------------------------------------------|-------------------------------------------------------------------------|
| <p>The Cisco Support website provides extensive online resources, including documentation and tools for troubleshooting and resolving technical issues with Cisco products and technologies.</p> <p>To receive security and technical information about your products, you can subscribe to various services, such as the Product Alert Tool (accessed from Field Notices), the Cisco Technical Services Newsletter, and Really Simple Syndication (RSS) Feeds.</p> <p>Access to most tools on the Cisco Support website requires a Cisco.com user ID and password.</p> | <a href="http://www.cisco.com/support">http://www.cisco.com/support</a> |

## Feature Information for Dynamic Bandwidth Sharing

Use Cisco Feature Navigator to find information about the platform support and software image support. Cisco Feature Navigator enables you to determine which software images support a specific software release, feature set, or platform. To access Cisco Feature Navigator, go to the <https://cfng.cisco.com/> link. An account on the Cisco.com page is not required.



**Note** The following table lists the software release in which a given feature is introduced. Unless noted otherwise, subsequent releases of that software release train also support that feature.

**Table 279: Feature Information for Dynamic Bandwidth Sharing**

| Feature Name              | Releases                    | Feature Information                                                                                               |
|---------------------------|-----------------------------|-------------------------------------------------------------------------------------------------------------------|
| Dynamic bandwidth sharing | Cisco IOS XE Everest 16.6.1 | This feature was integrated into Cisco IOS XE Everest 16.6.1 on the Cisco cBR Series Converged Broadband Routers. |



## CHAPTER 89

# Modular Quality of Service Command-Line Interface QoS

---

This module contains the concepts about applying QoS features using the Modular Quality of Service (QoS) Command-Line Interface (CLI) (MQC) and the tasks for configuring the MQC. The MQC allows you to define a traffic class, create a traffic policy (policy map), and attach the traffic policy to an interface. The traffic policy contains the QoS feature that will be applied to the traffic class.

- [Finding Feature Information, on page 1403](#)
- [Hardware Compatibility Matrix for the Cisco cBR Series Routers, on page 1403](#)
- [Restrictions for Applying QoS Features Using the MQC, on page 1405](#)
- [About, on page 1405](#)
- [How to Apply QoS Features Using the MQC, on page 1410](#)
- [Configuration Examples for Applying QoS Features Using the MQC, on page 1415](#)
- [How to Configure Input MQC on the Port-Channel Interfaces, on page 1419](#)
- [Example: Configuring Input MQC on the Port-Channel Interfaces, on page 1420](#)
- [Additional References, on page 1421](#)
- [Feature Information for Modular Quality of Service Command-Line Interface QoS, on page 1422](#)

## Finding Feature Information

Your software release may not support all the features documented in this module. For the latest caveats and feature information, see [Bug Search Tool](#) and the release notes for your platform and software release. To find information about the features documented in this module, and to see a list of the releases in which each feature is supported, see the feature information table.

Use Cisco Feature Navigator to find information about platform support and Cisco software image support. To access Cisco Feature Navigator, go to <https://cfng.cisco.com/>. An account on Cisco.com is not required.

## Hardware Compatibility Matrix for the Cisco cBR Series Routers



---

**Note** The hardware components that are introduced in a given Cisco IOS-XE Release are supported in all subsequent releases unless otherwise specified.

---

Table 280: Hardware Compatibility Matrix for the Cisco cBR Series Routers

| Cisco CMTS Platform                    | Processor Engine                                                                                                                                                                                  | Interface Cards                                                                                                                                                                                                                                                                                                                                                                                                                                                                                                                                                                                                                                                                                                                                                                                 |
|----------------------------------------|---------------------------------------------------------------------------------------------------------------------------------------------------------------------------------------------------|-------------------------------------------------------------------------------------------------------------------------------------------------------------------------------------------------------------------------------------------------------------------------------------------------------------------------------------------------------------------------------------------------------------------------------------------------------------------------------------------------------------------------------------------------------------------------------------------------------------------------------------------------------------------------------------------------------------------------------------------------------------------------------------------------|
| Cisco cBR-8 Converged Broadband Router | <p><b>Cisco IOS-XE Release 16.5.1 and Later Releases</b></p> <p>Cisco cBR-8 Supervisor:</p> <ul style="list-style-type: none"> <li>• PID—CBR-SUP-250G</li> <li>• PID—CBR-CCAP-SUP-160G</li> </ul> | <p><b>Cisco IOS-XE Release 16.5.1 and Later Releases</b></p> <p>Cisco cBR-8 CCAP Line Cards:</p> <ul style="list-style-type: none"> <li>• PID—CBR-LC-8D30-16U30</li> <li>• PID—CBR-LC-8D31-16U30</li> <li>• PID—CBR-RF-PIC</li> <li>• PID—CBR-RF-PROT-PIC</li> <li>• PID—CBR-CCAP-LC-40G</li> <li>• PID—CBR-CCAP-LC-40G-R</li> <li>• PID—CBR-CCAP-LC-G2-R</li> <li>• PID—CBR-SUP-8X10G-PIC</li> <li>• PID—CBR-2X100G-PIC</li> </ul> <p>Digital PICs:</p> <ul style="list-style-type: none"> <li>• PID—CBR-DPIC-8X10G</li> <li>• PID—CBR-DPIC-2X100G</li> </ul> <p>Cisco cBR-8 Downstream PHY Module:</p> <ul style="list-style-type: none"> <li>• PID—CBR-D31-DS-MOD</li> </ul> <p>Cisco cBR-8 Upstream PHY Modules:</p> <ul style="list-style-type: none"> <li>• PID—CBR-D31-US-MOD</li> </ul> |



**Note** Do not use DPICs (8X10G and 2x100G) to forward IP traffic, as it may cause buffer exhaustion, leading to line card reload.

The only allowed traffic on a DPIC interface is DEPI, UEPI, and GCP traffic from the Cisco cBR-8 router to Remote PHY devices. Other traffic such as DHCP, SSH, and UTSC should flow via another router, since DPICs cannot be used for normal routing.



# Restrictions for Applying QoS Features Using the MQC

The MQC-based QoS does not support classification of legacy Layer 2 protocol packets such as Internetwork Packet Exchange (IPX), DECnet, or AppleTalk. When these types of packets are being forwarded through a generic Layer 2 tunneling mechanism, the packets can be handled by MQC but without protocol classification. As a result, legacy protocol traffic in a Layer 2 tunnel is matched only by a "match any" class or class-default.

The number of QoS policy maps and class maps supported varies by platform and release.



---

**Note** The policy map limitations do not refer to the number of applied policy map instances, only to the definition of the policy maps.

---

## About

### The MQC Structure

The MQC (Modular Quality of Service (QoS) Command-Line Interface (CLI)) enables you to set packet classification and marking based on a QoS group value. MQC CLI allows you to create traffic classes and policies, enable a QoS feature (such as packet classification), and attach these policies to interfaces.

The MQC structure necessitates developing the following entities: traffic class, policy map, and service policy.

### Elements of a Traffic Class

A traffic class contains three major elements: a traffic class name, a series of **match** commands, and, if more than one **match** command is used in the traffic class, instructions on how to evaluate these **match** commands.

The **match** commands are used for classifying packets. Packets are checked to determine whether they meet the criteria specified in the **match** commands; if a packet meets the specified criteria, that packet is considered a member of the class. Packets that fail to meet the matching criteria are classified as members of the default traffic class.

#### Available match Commands

The table below lists *some* of the available **match** commands that can be used with the MQC. The available **match** commands vary by Cisco IOS XE release. For more information about the commands and command syntax, see the *Cisco IOS Quality of Service Solutions Command Reference*.

**Table 281: match Commands That Can Be Used with the MQC**

| Command                   | Purpose                                                                                                |
|---------------------------|--------------------------------------------------------------------------------------------------------|
| <b>match access-group</b> | Configures the match criteria for a class map on the basis of the specified access control list (ACL). |

| Command                                | Purpose                                                                                                                                                                                                                                                                                                                                                                                                                                                                                                                                                                                                          |
|----------------------------------------|------------------------------------------------------------------------------------------------------------------------------------------------------------------------------------------------------------------------------------------------------------------------------------------------------------------------------------------------------------------------------------------------------------------------------------------------------------------------------------------------------------------------------------------------------------------------------------------------------------------|
| <b>match any</b>                       | Configures the match criteria for a class map to be successful match criteria for all packets.                                                                                                                                                                                                                                                                                                                                                                                                                                                                                                                   |
| <b>match cos</b>                       | Matches a packet based on a Layer 2 class of service (CoS) marking.                                                                                                                                                                                                                                                                                                                                                                                                                                                                                                                                              |
| <b>match destination-address mac</b>   | Uses the destination MAC address as a match criterion.                                                                                                                                                                                                                                                                                                                                                                                                                                                                                                                                                           |
| <b>match discard-class</b>             | Matches packets of a certain discard class.                                                                                                                                                                                                                                                                                                                                                                                                                                                                                                                                                                      |
| <b>match [ip] dscp</b>                 | Identifies a specific IP differentiated service code point (DSCP) value as a match criterion. Up to eight DSCP values can be included in one match statement.                                                                                                                                                                                                                                                                                                                                                                                                                                                    |
| <b>match input-interface</b>           | Configures a class map to use the specified input interface as a match criterion.                                                                                                                                                                                                                                                                                                                                                                                                                                                                                                                                |
| <b>match ip rtp</b>                    | Configures a class map to use the Real-Time Transport Protocol (RTP) port as the match criterion.                                                                                                                                                                                                                                                                                                                                                                                                                                                                                                                |
| <b>match mpls experimental</b>         | Configures a class map to use the specified value of the Multiprotocol Label Switching (MPLS) experimental (EXP) field as a match criterion.                                                                                                                                                                                                                                                                                                                                                                                                                                                                     |
| <b>match mpls experimental topmost</b> | Matches the MPLS EXP value in the topmost label.                                                                                                                                                                                                                                                                                                                                                                                                                                                                                                                                                                 |
| <b>match not</b>                       | Specifies the single match criterion value to use as an unsuccessful match criterion.<br><br><b>Note</b> The <b>match not</b> command, rather than identifying the specific match parameter to use as a match criterion, is used to specify a match criterion that prevents a packet from being classified as a member of the class. For instance, if the <b>match not qos-group 6</b> command is issued while you configure the traffic class, QoS group 6 becomes the only QoS group value that is not considered a successful match criterion. All other QoS group values would be successful match criteria. |
| <b>match packet length</b>             | Specifies the Layer 3 packet length in the IP header as a match criterion in a class map.                                                                                                                                                                                                                                                                                                                                                                                                                                                                                                                        |
| <b>match port-type</b>                 | Matches traffic on the basis of the port type for a class map.                                                                                                                                                                                                                                                                                                                                                                                                                                                                                                                                                   |
| <b>match [ip] precedence</b>           | Identifies IP precedence values as match criteria.                                                                                                                                                                                                                                                                                                                                                                                                                                                                                                                                                               |
| <b>match protocol</b>                  | Configures the match criteria for a class map on the basis of the specified protocol.<br><br><b>Note</b> A separate <b>match protocol</b> (NBAR) command is used to configure network-based application recognition (NBAR) to match traffic by a protocol type known to NBAR.                                                                                                                                                                                                                                                                                                                                    |
| <b>match protocol fasttrack</b>        | Configures NBAR to match FastTrack peer-to-peer traffic.                                                                                                                                                                                                                                                                                                                                                                                                                                                                                                                                                         |

| Command                         | Purpose                                                                                                                                                               |
|---------------------------------|-----------------------------------------------------------------------------------------------------------------------------------------------------------------------|
| <b>match protocol gnutella</b>  | Configures NBAR to match Gnutella peer-to-peer traffic.                                                                                                               |
| <b>match protocol http</b>      | Configures NBAR to match Hypertext Transfer Protocol (HTTP) traffic by URL, host, Multipurpose Internet Mail Extension (MIME) type, or fields in HTTP packet headers. |
| <b>match protocol rtp</b>       | Configures NBAR to match RTP traffic.                                                                                                                                 |
| <b>match qos-group</b>          | Identifies a specific QoS group value as a match criterion.                                                                                                           |
| <b>match source-address mac</b> | Uses the source MAC address as a match criterion.                                                                                                                     |

### Multiple match Commands in One Traffic Class

If the traffic class contains more than one **match** command, you need to specify how to evaluate the **match** commands. You specify this by using either the **match-any** or **match-all** keyword of the **class-map** command. Note the following points about the **match-any** and **match-all** keywords:

- If you specify the **match-any** keyword, the traffic being evaluated by the traffic class must match *one* of the specified criteria.
- If you specify the **match-all** keyword, the traffic being evaluated by the traffic class must match *all* of the specified criteria.
- If you do not specify either keyword, the traffic being evaluated by the traffic class must match *all* of the specified criteria (that is, the behavior of the **match-all** keyword is used).

## Elements of a Traffic Policy

A traffic policy contains three elements: a traffic policy name, a traffic class (specified with the **class** command), and the command used to enable the QoS feature.

The traffic policy (policy map) applies the enabled QoS feature to the traffic class once you attach the policy map to the interface (by using the **service-policy** command).



**Note** A packet can match only *one* traffic class within a traffic policy. If a packet matches more than one traffic class in the traffic policy, the *first* traffic class defined in the policy will be used.

### Commands Used to Enable QoS Features

The commands used to enable QoS features vary by Cisco IOS XE release. The table below lists *some* of the available commands and the QoS features that they enable. For complete command syntax, see the *Cisco IOS QoS Command Reference*.

For more information about a specific QoS feature that you want to enable, see the appropriate module of the Cisco IOS XE Quality of Service Solutions Configuration Guide.

Table 282: Commands Used to Enable QoS Features

| Command                                             | Purpose                                                                                                                                                                                                                                                                                                                                                                                                                                            |
|-----------------------------------------------------|----------------------------------------------------------------------------------------------------------------------------------------------------------------------------------------------------------------------------------------------------------------------------------------------------------------------------------------------------------------------------------------------------------------------------------------------------|
| <b>bandwidth</b>                                    | Configures a minimum bandwidth guarantee for a class.                                                                                                                                                                                                                                                                                                                                                                                              |
| <b>bandwidth remaining</b>                          | Configures an excess weight for a class.                                                                                                                                                                                                                                                                                                                                                                                                           |
| <b>fair-queue</b>                                   | Enables the flow-based queueing feature within a traffic class.                                                                                                                                                                                                                                                                                                                                                                                    |
| <b>fair-queue pre-classify</b>                      | Configures and checks whether the <b>qos pre-classify</b> command can be used for fair queue. When the <b>qos pre-classify</b> command is enabled on the tunnel interface, and then the <b>fair-queue pre-classify</b> command is enabled for the policy-map, the policy-map is attached to either the tunnel interface or the physical interface.<br><br>The inner IP header of the tunnel will be used for the hash algorithm of the fair queue. |
| <b>drop</b>                                         | Discards the packets in the specified traffic class.                                                                                                                                                                                                                                                                                                                                                                                               |
| <b>police</b>                                       | Configures traffic policing.                                                                                                                                                                                                                                                                                                                                                                                                                       |
| <b>police (percent)</b>                             | Configures traffic policing on the basis of a percentage of bandwidth available on an interface.                                                                                                                                                                                                                                                                                                                                                   |
| <b>police (two rates)</b>                           | Configures traffic policing using two rates, the committed information rate (CIR) and the peak information rate (PIR).                                                                                                                                                                                                                                                                                                                             |
| <b>priority</b>                                     | Gives priority to a class of traffic belonging to a policy map.                                                                                                                                                                                                                                                                                                                                                                                    |
| <b>queue-limit</b>                                  | Specifies or modifies the maximum number of packets the queue can hold for a class configured in a policy map.                                                                                                                                                                                                                                                                                                                                     |
| <b>random-detect</b>                                | Enables Weighted Random Early Detection (WRED).                                                                                                                                                                                                                                                                                                                                                                                                    |
| <b>random-detect discard-class</b>                  | Configures the WRED parameters for a discard-class value for a class in a policy map.                                                                                                                                                                                                                                                                                                                                                              |
| <b>random-detect discard-class-based</b>            | Configures WRED on the basis of the discard class value of a packet.                                                                                                                                                                                                                                                                                                                                                                               |
| <b>random-detect exponential-weighting-constant</b> | Configures the exponential weight factor for the average queue size calculation for the queue reserved for a class.                                                                                                                                                                                                                                                                                                                                |
| <b>random-detect precedence</b>                     | Configure the WRED parameters for a particular IP Precedence for a class policy in a policy map.                                                                                                                                                                                                                                                                                                                                                   |
| <b>service-policy</b>                               | Specifies the name of a traffic policy used as a matching criterion (for nesting traffic policies [hierarchical traffic policies] within one another).                                                                                                                                                                                                                                                                                             |
| <b>set atm-clp</b>                                  | Sets the cell loss priority (CLP) bit when a policy map is configured.                                                                                                                                                                                                                                                                                                                                                                             |
| <b>set cos</b>                                      | Sets the Layer 2 class of service (CoS) value of an outgoing packet.                                                                                                                                                                                                                                                                                                                                                                               |
| <b>set discard-class</b>                            | Marks a packet with a discard-class value.                                                                                                                                                                                                                                                                                                                                                                                                         |

| Command                      | Purpose                                                                                                                              |
|------------------------------|--------------------------------------------------------------------------------------------------------------------------------------|
| <b>set [ip] dscp</b>         | Marks a packet by setting the differentiated services code point (DSCP) value in the type of service (ToS) byte.                     |
| <b>set fr-de</b>             | Changes the discard eligible (DE) bit setting in the address field of a Frame Relay frame to 1 for all traffic leaving an interface. |
| <b>set mpls experimental</b> | Designates the value to which the MPLS bits are set if the packets match the specified policy map.                                   |
| <b>set precedence</b>        | Sets the precedence value in the packet header.                                                                                      |
| <b>set qos-group</b>         | Sets a QoS group identifier (ID) that can be used later to classify packets.                                                         |
| <b>shape</b>                 | Shapes traffic to the indicated bit rate according to the algorithm specified.                                                       |

## Nested Traffic Classes

The MQC does not necessarily require that you associate only one traffic class to one traffic policy.

In a scenario where packets satisfy more than one match criterion, the MQC enables you to associate multiple traffic classes with a single traffic policy (also termed *nested traffic classes*) using the **match class-map** command. (We term these *nested class maps* or *MQC Hierarchical class maps*.) This command provides the only method of combining match-any and match-all characteristics within a single traffic class. By doing so, you can create a traffic class using one match criterion evaluation instruction (either match-any or match-all) and then use that traffic class as a match criterion in a traffic class that uses a different match criterion type. For example, a traffic class created with the match-any instruction must use a class configured with the match-all instruction as a match criterion, or vice versa.

Consider this likely scenario: Suppose A, B, C, and D were all separate match criterion, and you wanted traffic matching A, B, or C and D (i.e., A or B or [C and D]) to be classified as belonging to a traffic class. Without the nested traffic class, traffic would either have to match all four of the match criterion (A and B and C and D) or match any of the match criterion (A or B or C or D) to be considered part of the traffic class. You would not be able to combine “and” (match-all) and “or” (match-any) statements within the traffic class; you would be unable to configure the desired configuration.

The solution: Create one traffic class using match-all for C and D (which we will call criterion E), and then create a new match-any traffic class using A, B, and E. The new traffic class would have the correct evaluation sequence (A or B or E, which is equivalent to A or B or [C and D]).

## match-all and match-any Keywords of the class-map Command

One of the commands used when you create a traffic class is the **class-map** command. The command syntax for the **class-map** command includes two keywords: **match-all** and **match-any**. The **match-all** and **match-any** keywords need to be specified only if more than one match criterion is configured in the traffic class. Note the following points about these keywords:

- The **match-all** keyword is used when *all* of the match criteria in the traffic class must be met in order for a packet to be placed in the specified traffic class.
- The **match-any** keyword is used when only *one* of the match criterion in the traffic class must be met in order for a packet to be placed in the specified traffic class.

- If neither the **match-all** keyword nor **match-any** keyword is specified, the traffic class will behave in a manner consistent with the **match-all** keyword.

## input and output Keywords of the service-policy Command

As a general rule, the QoS features configured in the traffic policy can be applied to packets entering the interface or to packets leaving the interface. Therefore, when you use the **service-policy** command, you need to specify the direction of the traffic policy by using the **input** or **output** keyword.

For instance, the **service-policy output policy-map1** command would apply the QoS features in the traffic policy to the interface in the output direction. All packets leaving the interface (output) are evaluated according to the criteria specified in the traffic policy named policy-map1.



---

**Note** For Cisco releases, queueing mechanisms are not supported in the input direction. Nonqueueing mechanisms (such as traffic policing and traffic marking) are supported in the input direction. Also, classifying traffic on the basis of the source MAC address (using the **match source-address mac** command) is supported in the input direction only.

---

## Benefits of Applying QoS Features Using the MQC

The MQC structure allows you to create the traffic policy (policy map) once and then apply it to as many traffic classes as needed. You can also attach the traffic policies to as many interfaces as needed.

## How to Apply QoS Features Using the MQC

### Creating a Traffic Class

To create a traffic class, use the **class-map** command to specify the traffic class name. Then use one or more **match** commands to specify the appropriate match criteria. Packets matching the criteria that you specify are placed in the traffic class. For more information about the **match-all** and **match-any** keywords of the class-map command, see the “match-all and match-any Keywords of the class-map Command” section.



---

**Note** The **match cos** command is shown in Step 4. The **match cos** command is simply an example of one of the **match** commands that you can use. For information about the other available **match** commands, see the “match-all and match-any Keywords of the class-map Command” section.

---

**Step 1**    **enable**

**Example:**

```
Router> enable
```

Enables privileged EXEC mode.

- Enter your password if prompted.

**Step 2** **configure terminal****Example:**

```
Router# configure terminal
```

Enters global configuration mode.

**Step 3** **class-map** [**match-all** | **match-any**] *class-map-name***Example:**

```
Router(config)# class-map match-any class1
```

Creates a class to be used with a class map and enters class-map configuration mode.

- The class map is used for matching packets to the specified class.
- Enter the class name.

**Note** The **match-all** keyword specifies that all match criteria must be met. The **match-any** keyword specifies that one of the match criterion must be met. Use these keywords only if you will be specifying more than one **match** command.

**Step 4** **match cos** *cos-number***Example:**

```
Router(config-cmap)# match cos 2
```

Matches a packet on the basis of a Layer 2 class of service (CoS) number.

- Enter the CoS number.

**Note** The **match cos** command is an example of the **match** commands you can use. For information about the other **match** commands that are available, see the “match-all and match-any Keywords of the class-map Command” section.

**Step 5** Enter additional match commands, if applicable; otherwise, continue with step 6.

```
--
```

**Step 6** **end****Example:**

```
Router(config-cmap)# end
```

(Optional) Exits QoS class-map configuration mode and returns to privileged EXEC mode.

## Creating a Traffic Policy



**Note** The **bandwidth** command is shown in Step 5. The **bandwidth** command is an example of the commands that you can use in a policy map to enable a QoS feature (in this case, Class-based Weighted Fair Queuing (CBWFQ)). For information about other available commands, see the “Elements of a Traffic Policy” section.

### Step 1 enable

#### Example:

```
Router> enable
```

Enables privileged EXEC mode.

- Enter your password if prompted.

### Step 2 configure terminal

#### Example:

```
Router# configure terminal
```

Enters global configuration mode.

### Step 3 policy-map *policy-map-name*

#### Example:

```
Router(config)# policy-map policy1
```

Creates or specifies the name of the traffic policy and enters QoS policy-map configuration mode.

- Enter the policy map name.

### Step 4 class {*class-name* | **class-default**}

#### Example:

```
Router(config-pmap)# class class1
```

Specifies the name of a traffic class and enters QoS policy-map class configuration mode.

**Note** This step associates the traffic class with the traffic policy.

### Step 5 bandwidth {*bandwidth-kbps* | **percent percent**}

#### Example:

```
Router(config-pmap-c)# bandwidth 3000
```

(Optional) Specifies a minimum bandwidth guarantee to a traffic class in periods of congestion.

- A minimum bandwidth guarantee can be specified in kb/s or by a percentage of the overall available bandwidth.



**Note** The **bandwidth** command enables CBWFQ. The **bandwidth** command is an example of the commands that you can use in a policy map to enable a QoS feature. For information about the other commands available, see the “Elements of a Traffic Policy” section.

**Step 6** Enter the commands for any additional QoS feature that you want to enable, if applicable; otherwise, continue with Step 7.

--

**Step 7** **end**

**Example:**

```
Router(config-pmap-c)# end
```

(Optional) Exits QoS policy-map class configuration mode and returns to privileged EXEC mode.

## Attaching a Traffic Policy to an Interface Using the MQC

### Procedure

|               | Command or Action                                                                                                                                       | Purpose                                                                                                                         |
|---------------|---------------------------------------------------------------------------------------------------------------------------------------------------------|---------------------------------------------------------------------------------------------------------------------------------|
| <b>Step 1</b> | <b>enable</b><br><b>Example:</b><br><br>Router> enable                                                                                                  | Enables privileged EXEC mode.<br><br>• Enter your password if prompted.                                                         |
| <b>Step 2</b> | <b>configure terminal</b><br><b>Example:</b><br><br>Router# configure terminal                                                                          | Enters global configuration mode.                                                                                               |
| <b>Step 3</b> | <b>interface</b> <i>type number</i><br><b>Example:</b><br><br>Router(config)# interface TenGigabitEthernet 4/1/0                                        | Configures an interface type and enters interface configuration mode.<br><br>• Enter the interface type and interface number.   |
| <b>Step 4</b> | <b>service-policy</b> { <b>input</b>   <b>output</b> } <i>policy-map-name</i><br><b>Example:</b><br><br>Router(config-if)# service-policy input policy1 | Attaches a policy map to an interface.<br><br>• Enter either the <b>input</b> or <b>output</b> keyword and the policy map name. |
| <b>Step 5</b> | <b>end</b><br><b>Example:</b><br><br>Router(config-if)# end                                                                                             | (Optional) Exits interface configuration mode and returns to privileged EXEC mode.                                              |

## Verifying the Traffic Class and Traffic Policy Information

The show commands described in this section are optional and can be entered in any order.

### Procedure

|               | Command or Action                                                                                                                        | Purpose                                                                                                                                                                                                                |
|---------------|------------------------------------------------------------------------------------------------------------------------------------------|------------------------------------------------------------------------------------------------------------------------------------------------------------------------------------------------------------------------|
| <b>Step 1</b> | <b>enable</b><br><b>Example:</b><br>Router> enable                                                                                       | Enables privileged EXEC mode. <ul style="list-style-type: none"> <li>• Enter your password if prompted.</li> </ul>                                                                                                     |
| <b>Step 2</b> | <b>show class-map</b><br><b>Example:</b><br>Router# show class-map                                                                       | (Optional) Displays all class maps and their matching criteria.                                                                                                                                                        |
| <b>Step 3</b> | <b>show policy-map <i>policy-map-name</i> class <i>class-name</i></b><br><b>Example:</b><br>Router# show policy-map policy1 class class1 | (Optional) Displays the configuration for the specified class of the specified policy map. <ul style="list-style-type: none"> <li>• Enter the policy map name and the class name.</li> </ul>                           |
| <b>Step 4</b> | <b>show policy-map</b><br><b>Example:</b><br>Router# show policy-map                                                                     | (Optional) Displays the configuration of all classes for all existing policy maps.                                                                                                                                     |
| <b>Step 5</b> | <b>show policy-map interface <i>type number</i></b><br><b>Example:</b><br>Router# show policy-map interface<br>TengigabitEthernet 4/1/0  | (Optional) Displays the statistics and the configurations of the input and output policies that are attached to an interface. <ul style="list-style-type: none"> <li>• Enter the interface type and number.</li> </ul> |
| <b>Step 6</b> | <b>exit</b><br><b>Example:</b><br>Router# exit                                                                                           | (Optional) Exits privileged EXEC mode.                                                                                                                                                                                 |

# Configuration Examples for Applying QoS Features Using the MQC

## Creating a Traffic Class

In the following example, we create traffic classes and define their match criteria. For the first traffic class (`class1`), we use access control list (ACL) 101 as match criteria; for the second traffic class (`class2`), ACL 102. We check the packets against the contents of these ACLs to determine if they belong to the class.

```
class-map class1
  match access-group 101
  exit
class-map class2
  match access-group 102
  end
```

## Creating a Policy Map

In the following example, we define a traffic policy (`policy1`) containing the QoS features that we will apply to two classes: `class1` and `class2`. The match criteria for these classes were previously defined in [Creating a Traffic Class, on page 1415](#).

For `class1`, the policy includes a bandwidth allocation request and a maximum packet count limit for the queue reserved for that class. For `class2`, the policy specifies only a bandwidth allocation request.

```
policy-map policy1
  class class1
    bandwidth 3000
    queue-limit 30
    exit
  class class2
    bandwidth 2000
  end
```

## Example: Attaching a Traffic Policy to an Interface

The following example shows how to attach an existing traffic policy to an interface. After you define a traffic policy with the `policy-map` command, you can attach it to one or more interfaces by using the `service-policy` command in interface configuration mode. Although you can assign the same traffic policy to multiple interfaces, each interface can have only one traffic policy attached in the input direction and only one traffic policy attached in the output direction.

```
Router(config)# interface TengigabitEthernet 4/1/0
Router(config-if)# service-policy output policy1
Router(config-if)# exit
Router(config)# interface TengigabitEthernet 4/1/0
Router(config-if)# service-policy output policy1
Router(config-if)# end
```

## Using the match not Command

Use the **match not** command to specify a QoS policy value that is not used as a match criterion. All other values of that QoS policy become successful match criteria. For instance, if you issue the **match not qos-group 4** command in QoS class-map configuration mode, the specified class will accept all QoS group values except 4 as successful match criteria.

In the following traffic class, all protocols except IP are considered successful match criteria:

```
class-map noip
  match not protocol ip
end
```

## Configuring a Default Traffic Class

Traffic that does not meet the match criteria specified in the traffic classes (that is, *unclassified traffic*) is treated as belonging to the default traffic class.

If you do not configure a default class, packets are still treated as members of that class. The default class has no QoS features enabled so packets belonging to this class have no QoS functionality. Such packets are placed into a first-in, first-out (FIFO) queue managed by tail drop, which is a means of avoiding congestion that treats all traffic equally and does not differentiate between classes of service. Queues fill during periods of congestion. When the output queue is full and tail drop is active, packets are dropped until the congestion is eliminated and the queue is no longer full.

The following example configures a policy map (policy1) for the default class (always called class-default) with these characteristics: 10 queues for traffic that does not meet the match criteria of other classes whose policy is defined by class policy1, and a maximum of 20 packets per queue before tail drop is enacted to handle additional queued packets.

In the following example, we configure a policy map (policy1) for the default class (always termed class-default) with these characteristics: 10 queues for traffic that does not meet the match criterion of other classes whose policy is defined by the traffic policy policy1.

```
policy-map policy1
  class class-default
    shape average 100m
```

## How Commands "class-map match-any" and "class-map match-all" Differ

This example shows how packets are evaluated when multiple match criteria exist. It illustrates the difference between the **class-map match-any** and **class-map match-all** commands. Packets must meet either all of the match criteria (**match-all**) or one of the match criteria (**match-any**) to be considered a member of the traffic class.

The following examples show a traffic class configured with the **class-map match-all** command:

```
class-map match-all cisco1
  match qos-group 4
  match access-group 101
```

If a packet arrives on a router with traffic class cisco1 configured on the interface, we assess whether it matches the IP protocol, QoS group 4, and access group 101. If all of these match criteria are met, the packet is classified

as a member of the traffic class `cisco1` (a logical AND operator; Protocol IP AND QoS group 4 AND access group 101).

```
class-map match-all vlan
  match vlan 1
  match vlan inner 1
```

The following example illustrates use of the `class-map match-any` command. Only one match criterion must be met for us to classify the packet as a member of the traffic class (i.e., a logical OR operator; protocol IP OR QoS group 4 OR access group 101):

```
class-map match-any cisco2
  match protocol ip
  match qos-group 4
  match access-group 101
```

In the traffic class `cisco2`, the match criterion are evaluated consecutively until a successful match is located. The packet is first evaluated to determine whether the IP protocol can be used as a match criterion. If so, the packet is matched to traffic class `cisco2`. If not, then QoS group 4 is evaluated as a match criterion and so on. If the packet matches none of the specified criteria, the packet is classified as a member of the default traffic class (*class default-class*).

## Establishing Traffic Class as a Match Criterion (Nested Traffic Classes)

There are two reasons to use the `match class-map` command. One reason is maintenance; if a large traffic class currently exists, using the traffic class match criterion is easier than retyping the same traffic class configuration. The second and more common reason is to mix match-all and match-any characteristics in one traffic policy. This enables you to create a traffic class using one match criterion evaluation instruction (either match-any or match-all) and then use that traffic class as a match criterion in a traffic class that uses a different match criterion type.

Consider this likely scenario: Suppose A, B, C, and D were all separate match criterion, and you wanted traffic matching A, B, or C and D (i.e., A or B or [C and D]) to be classified as belonging to a traffic class. Without the nested traffic class, traffic would either have to match all four of the match criterion (A and B and C and D) or match any of the match criterion (A or B or C or D) to be considered part of the traffic class. You would not be able to combine “and” (match-all) and “or” (match-any) statements within the traffic class; you would be unable to configure the desired configuration.

The solution: Create one traffic class using match-all for C and D (which we will call criterion E), and then create a new match-any traffic class using A, B, and E. The new traffic class would have the correct evaluation sequence (A or B or E, which is equivalent to A or B or [C and D]).

### Example: Nested Traffic Class for Maintenance

In the following example, the traffic class called `class1` has the same characteristics as the traffic class called `class2`, with the exception that traffic class `class1` has added a destination address as a match criterion. Rather than configuring traffic class `class1` line by line, you can enter the `match class-map class2` command. This command allows all of the characteristics in the traffic class called `class2` to be included in the traffic class called `class1`, and you can add the new destination address match criterion without reconfiguring the entire traffic class.

```
Router(config)# class-map match-any class2
```

```

Router(config-cmap) # match protocol ip
Router(config-cmap) # match qos-group 3
Router(config-cmap) # match access-group 2
Router(config-cmap) # exit
Router(config) # class-map match-all class1
Router(config-cmap) # match class-map class2
Router(config-cmap) # match destination-address mac 0000.0000.0000
Router(config-cmap) # exit

```

## Example: Nested Traffic Class to Combine match-any and match-all Characteristics in One Traffic Class

The only method of including both match-any and match-all characteristics in a single traffic class is to use the **match class-map** command. To combine match-any and match-all characteristics into a single class, use the match-any instruction to create a traffic class that uses a class configured with the match-all instruction as a match criterion (through the **match class-map** command).

The following example shows how to combine the characteristics of two traffic classes, one with match-any and one with match-all characteristics, into one traffic class with the **match class-map** command. The result requires a packet to match one of the following three match criteria to be considered a member of traffic class class4: IP protocol *and* QoS group 4, destination MAC address 00.00.00.00.00.00, or access group 2.

In this example, only the traffic class called class4 is used with the traffic policy called policy1.

```

Router(config) # class-map match-all class3
Router(config-cmap) # match protocol ip
Router(config-cmap) # match qos-group 4
Router(config-cmap) # exit
Router(config) # class-map match-any class4
Router(config-cmap) # match class-map class3
Router(config-cmap) # match destination-address mac 00.00.00.00.00.00
Router(config-cmap) # match access-group 2
Router(config-cmap) # exit
Router(config) # policy-map policy1
Router(config-pmap) # class class4
Router(config-pmap-c) # police 8100 1500 2504 conform-action transmit exceed-action
set-qos-transmit 4
Router(config-pmap-c) # end

```

## Example: Traffic Policy as a QoS Policy (Hierarchical Traffic Policies)

A traffic policy can be included in a QoS policy when the **service-policy** command is used in QoS policy-map class configuration mode. A traffic policy that contains a traffic policy is called a hierarchical traffic policy.

A hierarchical traffic policy contains a child policy and a parent policy. The child policy is the previously defined traffic policy that is being associated with the new traffic policy through the use of the **service-policy** command. The new traffic policy using the preexisting traffic policy is the parent policy. In the example in this section, the traffic policy called child is the child policy and traffic policy called parent is the parent policy.

Hierarchical traffic policies can be attached to subinterfaces. When hierarchical traffic policies are used, a single traffic policy (with a child and parent policy) can be used to shape and priority traffic on subinterfaces.

```

Router(config)# policy-map child
Router(config-pmap)# class voice
Router(config-pmap-c)# priority 50
Router(config)# policy-map parent
Router(config-pmap)# class class-default
Router(config-pmap-c)# shape average 10000000
Router(config-pmap-c)# service-policy child

```

The value used with the **shape** command is provisioned from the committed information rate (CIR) value from the service provider.

## How to Configure Input MQC on the Port-Channel Interfaces

To configure input MQC on a port-channel interface to differentiate traffic flow and set corresponding "qos-group" features, follow the steps given below.



### Restriction

- QoS actions like policing, shaping, WRED, and queuing are not supported.
- Input MQC cannot be configured on cable physical interfaces.

## Creating a Traffic Class

The **class-map** command is used to create a traffic class. A traffic class contains three major elements: a name, a series of **match** commands, and, if more than one **match** command exists in the traffic class, an instruction on how to evaluate these **match** commands.

The **match** commands are used to specify various criteria for classifying packets. Packets are checked to determine whether they match the criteria specified in the **match** commands; if a packet matches the specified criteria, that packet is considered a member of the class and is forwarded according to the QoS specifications set in the traffic policy. Packets that fail to meet any of the matching criteria are classified as members of the default traffic class.

To create traffic classes and define their match criteria, complete the following procedure:

```

configure terminal
class-map class
match type

```

## Creating a Policy Map

After creating traffic classes, you can configure traffic policies to configure marking features to apply certain actions to the selected traffic in those classes.

The **policy-map** command is used to create a traffic policy. The purpose of a traffic policy is to configure the QoS features that should be associated with the traffic that has been classified in a user-specified traffic class.



### Note

A packet can match only one traffic class within a traffic policy. If a packet matches more than one traffic class in the traffic policy, the first traffic class defined in the policy will be used.

To define a traffic policy, complete the following procedure:

```
configure terminal
policy-map policy
class class
```

## Defining QoS Actions in a Policy Map

Action commands can be added from within class mode on a policy map.

### Set Actions

**Set** commands allow traffic to be marked such that other network devices along the forwarding path can quickly determine the proper class of service to apply to a traffic flow.

To define a set action, complete the following procedure:

```
configure terminal
policy-map policy
class class
set option
```

## Configuring Aggregate Port-Channel Interface

To configure port-channel interface, complete the following procedure:

```
configure terminal
platform qos port-channel-aggregate port_channel_number
interface port-channel port_channel_number
ip address ip mask
interface name
channel-group number
```

## Attaching a Traffic Policy to an Interface

After you define a traffic policy with the **policy-map** command, you can attach it to one or more interfaces by using the **service-policy** command in interface configuration mode. Although you can assign the same traffic policy to multiple interfaces, each interface can have only one traffic policy attached in the input direction and only one traffic policy attached in the output direction.

To attach a traffic policy to an interface, complete the following procedure:

```
configure terminal
interface port-channel port_channel_number
service-policy input policy
```

## Example: Configuring Input MQC on the Port-Channel Interfaces

The following example shows how to configure input MQC on the port-channel interfaces.



```

Router# configure terminal
Router(config)# class-map class1
Router(config-cmap)# match any
Router(config-cmap)# exit
Router(config)# policy-map policy1
Router(config-pmap)# class class1
Router(config-pmap-c)# set dscp af11
Router(config-pmap-c)# exit
Router(config-pmap)# exit
Router(config)# platform qos port-channel-aggregate 2 Router(config)# interface port-channel
2
Router(config-if)# ip address 192.168.0.1 255.255.255.0
Router(config-if)# no shut
Router(config-if)# interface tenGigabitEthernet 4/1/1
Router(config-if)# no ip address
Router(config-if)# no shut
Router(config-if)# channel-group 2
Router(config-if)# interface port-channel 2
Router(config-if)# service-policy input policy1
Device(config-if)# end

```

## Additional References

### Related Documents

| Related Topic                                                                                                   | Document Title                                                                                                                                          |
|-----------------------------------------------------------------------------------------------------------------|---------------------------------------------------------------------------------------------------------------------------------------------------------|
| QoS commands: complete command syntax, command modes, command history, defaults, usage guidelines, and examples | <i>Cisco IOS Quality of Service Solutions Command Reference</i>                                                                                         |
| Packet classification                                                                                           | “Classifying Network Traffic” module                                                                                                                    |
| Frame Relay Fragmentation (FRF) PVCs                                                                            | “FRF .20 Support” module                                                                                                                                |
| Selective Packet Discard                                                                                        | “IPv6 Selective Packet Discard” module                                                                                                                  |
| Scaling and performance information                                                                             | “Broadband Scalability and Performance” module of the <a href="#">Cisco ASR 1000 Series Aggregation Services Routers Software Configuration Guide</a> . |

### Technical Assistance

| Description                                                                                                                                                                                                                                                                                                                                                                           | Link                                                                                                              |
|---------------------------------------------------------------------------------------------------------------------------------------------------------------------------------------------------------------------------------------------------------------------------------------------------------------------------------------------------------------------------------------|-------------------------------------------------------------------------------------------------------------------|
| The Cisco Support and Documentation website provides online resources to download documentation, software, and tools. Use these resources to install and configure the software and to troubleshoot and resolve technical issues with Cisco products and technologies. Access to most tools on the Cisco Support and Documentation website requires a Cisco.com user ID and password. | <a href="http://www.cisco.com/cisco/web/support/index.html">http://www.cisco.com/cisco/web/support/index.html</a> |

# Feature Information for Modular Quality of Service Command-Line Interface QoS

Use Cisco Feature Navigator to find information about the platform support and software image support. Cisco Feature Navigator enables you to determine which software images support a specific software release, feature set, or platform. To access Cisco Feature Navigator, go to the <https://cfng.cisco.com/> link. An account on the Cisco.com page is not required.



**Note** The following table lists the software release in which a given feature is introduced. Unless noted otherwise, subsequent releases of that software release train also support that feature.

**Table 283: Feature Information for Modular Quality of Service Command-Line Interface QoS**

| Feature Name                                          | Releases                    | Feature Information                                                                                           |
|-------------------------------------------------------|-----------------------------|---------------------------------------------------------------------------------------------------------------|
| Modular Quality of Service Command-Line Interface QoS | Cisco IOS XE Everest 16.6.1 | This feature was integrated into Cisco IOS XE Everest 16.6.1 on Cisco cBR Series Converged Broadband Routers. |
| Service Policy on Port-Channel Interfaces             | Cisco IOS XE Everest 16.6.1 | This feature was integrated into Cisco IOS XE Everest 16.6.1 on Cisco cBR Series Converged Broadband Routers. |



## CHAPTER 90

# DOCSIS 1.1 for the Cisco CMTS Routers

---

This document describes how to configure the Cisco CMTS router for Data-over-Cable Service Interface Specifications (DOCSIS) 1.1 operations.

Your software release may not support all the features that are documented in this module. For the latest feature information and caveats, see the release notes for your platform and software release. The Feature Information Table at the end of this document provides information about the documented features and lists the releases in which each feature is supported.

Use Cisco Feature Navigator to find information about platform support and Cisco software image support. To access Cisco Feature Navigator, go to <http://tools.cisco.com/ITDIT/CFN/>. An account on <http://www.cisco.com/> is not required.

### Contents

- [Hardware Compatibility Matrix for the Cisco cBR Series Routers, on page 1423](#)
- [Prerequisites for DOCSIS 1.1 Operations, on page 1425](#)
- [Restrictions for DOCSIS 1.1 Operations, on page 1425](#)
- [Information about DOCSIS 1.1, on page 1427](#)
- [How to Configure the Cisco CMTS for DOCSIS 1.1 Operations, on page 1440](#)
- [Monitoring DOCSIS Operations, on page 1452](#)
- [Configuration Examples for DOCSIS 1.1 Operations, on page 1458](#)
- [Additional References, on page 1461](#)
- [Feature Information for DOCSIS 1.1 for Cisco CMTS Routers, on page 1462](#)

## Hardware Compatibility Matrix for the Cisco cBR Series Routers



---

**Note** The hardware components that are introduced in a given Cisco IOS-XE Release are supported in all subsequent releases unless otherwise specified.

---

Table 284: Hardware Compatibility Matrix for the Cisco cBR Series Routers

| Cisco CMTS Platform                    | Processor Engine                                                                                                                                                                                  | Interface Cards                                                                                                                                                                                                                                                                                                                                                                                                                                                                                                                                                                                                                                                                                                                                                                                 |
|----------------------------------------|---------------------------------------------------------------------------------------------------------------------------------------------------------------------------------------------------|-------------------------------------------------------------------------------------------------------------------------------------------------------------------------------------------------------------------------------------------------------------------------------------------------------------------------------------------------------------------------------------------------------------------------------------------------------------------------------------------------------------------------------------------------------------------------------------------------------------------------------------------------------------------------------------------------------------------------------------------------------------------------------------------------|
| Cisco cBR-8 Converged Broadband Router | <p><b>Cisco IOS-XE Release 16.5.1 and Later Releases</b></p> <p>Cisco cBR-8 Supervisor:</p> <ul style="list-style-type: none"> <li>• PID—CBR-SUP-250G</li> <li>• PID—CBR-CCAP-SUP-160G</li> </ul> | <p><b>Cisco IOS-XE Release 16.5.1 and Later Releases</b></p> <p>Cisco cBR-8 CCAP Line Cards:</p> <ul style="list-style-type: none"> <li>• PID—CBR-LC-8D30-16U30</li> <li>• PID—CBR-LC-8D31-16U30</li> <li>• PID—CBR-RF-PIC</li> <li>• PID—CBR-RF-PROT-PIC</li> <li>• PID—CBR-CCAP-LC-40G</li> <li>• PID—CBR-CCAP-LC-40G-R</li> <li>• PID—CBR-CCAP-LC-G2-R</li> <li>• PID—CBR-SUP-8X10G-PIC</li> <li>• PID—CBR-2X100G-PIC</li> </ul> <p>Digital PICs:</p> <ul style="list-style-type: none"> <li>• PID—CBR-DPIC-8X10G</li> <li>• PID—CBR-DPIC-2X100G</li> </ul> <p>Cisco cBR-8 Downstream PHY Module:</p> <ul style="list-style-type: none"> <li>• PID—CBR-D31-DS-MOD</li> </ul> <p>Cisco cBR-8 Upstream PHY Modules:</p> <ul style="list-style-type: none"> <li>• PID—CBR-D31-US-MOD</li> </ul> |



**Note** Do not use DPICs (8X10G and 2x100G) to forward IP traffic, as it may cause buffer exhaustion, leading to line card reload.

The only allowed traffic on a DPIC interface is DEPI, UEPI, and GCP traffic from the Cisco cBR-8 router to Remote PHY devices. Other traffic such as DHCP, SSH, and UTSC should flow via another router, since DPICs cannot be used for normal routing.

# Prerequisites for DOCSIS 1.1 Operations

To support DOCSIS 1.1 operations, the cable modem must also support the DOCSIS 1.1 feature set. In addition, before you power on and configure the Cisco CMTS, check the following points:

- Ensure that your network supports reliable broadband data transmission. Your plant must be swept, balanced, and certified, based on NTSC or appropriate international cable plant recommendations. Ensure that your plant meets all DOCSIS downstream and upstream RF requirements.
- Ensure that your Cisco CMTS is installed according to the instructions provided in the appropriate Hardware Installation Guide. The chassis must contain at least one port adapter to provide backbone connectivity and one Cisco cable line card to serve as the RF cable TV interface.
- Ensure that all other required headend or distribution hub routing and network interface equipment is installed, configured, and operational, based on the services to support. This includes all routers, servers (DHCP, TFTP, and ToD), network management systems, and other configuration or billing systems. This includes IP telephony equipment including gatekeepers and gateways; backbone and other equipment if supporting virtual private networks (VPNs); and dialup access servers, telephone circuits and connections and other equipment if supporting telco return.
- Ensure that DHCP and DOCSIS configuration files have been created and pushed to appropriate servers such that each cable modem, when initialized, can transmit a DHCP request, receive an IP address, obtain TFTP and ToD server addresses, and download DOCSIS configuration files. Optionally, ensure that your servers can also download updated software images to DOCSIS 1.0 and DOCSIS 1.1 cable modems.
- Ensure that customer premises equipment (CPE)—cable modems or set-top boxes, PCs, telephones, or facsimile machines—meet the requirements for your network and service offerings.
- Familiarize yourself with your channel plan to ensure assigning of appropriate frequencies. Outline your strategies for setting up bundling or VPN solution sets, if applicable, to your headend or distribution hub. Know your dial plan if using H.323 for VoIP services and setting up VoIP-enabled cable modem configuration files. Obtain passwords, IP addresses, subnet masks, and device names, as appropriate.
- Ensure that the system clocks on the Cisco CMTS and on the time-of-day (ToD) servers are synchronized. If this does not occur, the clocks on the CMs will not match the clocks on the Cisco CMTS, which could interfere with BPI+ operations. In particular, this could prevent the proper verification of the digital certificates on the cable modem (CM).

After these prerequisites are met, you are ready to configure the Cisco CMTS. This includes, at a minimum, configuring a host name and password for the Cisco CMTS and configuring the Cisco CMTS to support IP over the cable plant and network backbone.

**Caution**

If you plan to use service-class-based provisioning, the service classes must be configured at the Cisco CMTS before cable modems attempt to make a connection. Use the **cable service class** command to configure service classes.

## Restrictions for DOCSIS 1.1 Operations

DOCSIS 1.1 operations includes the following restrictions:

### Baseline Privacy Interface Plus Requirements

BPI+ encryption and authentication must be supported and enabled by both the cable modem and CMTS. In addition, the cable modem must contain a digital certificate that conforms to the DOCSIS 1.1 and BPI+ specifications.

Also, ensure that the system clocks on the CMTS and on the time-of-day (ToD) servers are synchronized. If this does not occur, the clocks on the CMs will not match the clocks on the CMTS, which could interfere with BPI+ operations. In particular, this could prevent the proper verification of the digital certificates on the CM.



---

**Note** Ensure that the system clocks on the CMTS and on the time-of-day (ToD) servers are synchronized. If this does not occur, the clocks on the CMs will not match the clocks on the CMTS, which could interfere with BPI+ operations. In particular, this could prevent the proper verification of the digital certificates on the CM.

---

### BPI+-Encrypted Multicast Not Supported with Bundled Subinterfaces on the Cisco cBR-8 Router

The current Cisco IOS-XE releases do not support using BPI+ encrypted multicast on bundled cable subinterfaces on the Cisco cBR-8 router. Encrypted multicast is supported on bundled cable interfaces or on non-bundled cable subinterfaces, but not when a subinterface is bundled on the Cisco cBR-8 router.

### BPI+ Not Supported with High Availability Configurations

The current Cisco IOS-XE releases do not support using BPI+ encrypted multicast on a cable interface when the interface has also been configured for N+1 (1:n) High Availability or Remote Processor Redundancy Plus (RPR+) High Availability redundancy.

In addition, BPI+ is not automatically supported after a switchover from the Working cable interface to the Protect cable interface, because the cable interface configurations that are required for BPI+ encryption are not automatically synchronized between the two interfaces. A workaround for this is to manually configure the Protect cable interfaces with the required configurations.

### DOCSIS Root Certificates

The Cisco CMTS supports only one DOCSIS Root CA certificate.

### Maximum Burst Size

Previously, the maximum concatenated burst size parameter could be set to zero to specify an unlimited value. In a DOCSIS 1.1 environment, this parameter should be set to a nonzero value, with a maximum value of 1522 bytes for DOCSIS 1.0 cable modems.

If a cable modem attempts to register with a maximum concatenation burst size of zero, the DOCSIS 1.1 CMTS refuses to allow the cable modem to come online. This avoids the possibility that a DOCSIS 1.0 cable modem could interfere with voice traffic on the upstream by sending extremely large data packets. Since DOCSIS 1.0 does not support fragmentation, transmitting such data packets could result in unwanted jitter in the voice traffic.

In addition, DOCSIS 1.1 requires that the maximum transmit burst size be set to either 1522 bytes or the maximum concatenated burst size, whichever is larger. Do not set the maximum concatenation burst size to values larger than 1522 bytes for DOCSIS 1.0 cable modems.



---

**Note** This change requires you to change any DOCSIS configuration files that specify a zero value for the maximum concatenation burst size. This limitation does not exist for DOCSIS 1.1 cable modems unless fragmentation has been disabled.

---

### Performance

DOCSIS 1.0 cable modems lack the ability to explicitly request and provide scheduling parameters for advanced DOCSIS 1.1 scheduling mechanisms, such as unsolicited grants and real-time polling. DOCSIS 1.1 cable modems on the same upstream channel can benefit from the advanced scheduling mechanisms and a DOCSIS 1.1 CMTS can still adequately support voice traffic from DOCSIS 1.1 cable modems with DOCSIS 1.0 cable modems on the same upstream channel.

### Provisioning

The format and content of the TFTP configuration file for a DOCSIS 1.1 cable modem are significantly different from the file for a DOCSIS 1.0 cable modem. A dual-mode configuration file editor is used to generate a DOCSIS 1.0 style configuration file for DOCSIS 1.0 cable modems and a DOCSIS 1.1 configuration file for DOCSIS 1.1 cable modems.

### Registration

A DOCSIS 1.1 CMTS must handle the existing registration Type/Length/Value parameters from DOCSIS 1.0 cable modems as well as the new type TLVs from DOCSIS 1.1 cable modems. A DOCSIS 1.0 and DOCSIS 1.1 cable modem can successfully register with the same DOCSIS 1.1 CMTS.

A DOCSIS 1.1 cable modem can be configured to make an indirect reference to a service class that has been statically defined at the CMTS instead of explicitly asking for the service class parameters. When this registration request is received by a DOCSIS 1.1 CMTS, it encodes the actual parameters of the service class in the registration response and expects a DOCSIS 1.1-specific registration-acknowledge MAC message from the cable modem.

When a DOCSIS 1.0 cable modem registers with a DOCSIS 1.1 CMTS, the registration request explicitly requests all nondefault service-class parameters in the registration. The absence of an indirect service class reference eliminates the need for the DOCSIS 1.1 TLVs and eliminates the need to establish a local registration acknowledge wait state.

When a DOCSIS 1.1 CMTS receives a registration request from a DOCSIS 1.0 cable modem, it responds with the DOCSIS 1.0 style registration response and does not expect the cable modem to send the registration-acknowledge MAC message.

## Information about DOCSIS 1.1

DOCSIS 1.1 is the first major revision of the initial DOCSIS 1.0 standard for cable networks. Although the initial standard provided quality data traffic over the coaxial cable network, the demands of real-time traffic such as voice and video required many changes to the DOCSIS specification.

The DOCSIS 1.1 specification provides the following feature enhancements over DOCSIS 1.0 networks:

## Baseline Privacy Interface Plus

DOCSIS 1.0 introduced a Baseline Privacy Interface (BPI) to protect user data privacy across the shared-medium cable network and to prevent unauthorized access to DOCSIS-based data transport services across the cable network. BPI encrypts traffic across the RF interface between the cable modem and CMTS, and also includes authentication, authorization, and accounting (AAA) features.

BPI supports access control lists (ACLs), tunnels, filtering, protection against spoofing, and commands to configure source IP filtering on RF subnets to prevent subscribers from using source IP addresses that are not valid. DOCSIS 1.1 enhances these security features with BPI Plus (BPI+), which includes the following enhancements:

- X.509 Digital certificates provide secure user identification and authentication. The Cisco CMTS supports both self-signed manufacturer's certificates and certificates that are chained to the DOCSIS Root CA certificate.
- Key encryption uses 168-bit Triple DES (3DES) encryption that is suitable for the most sensitive applications.
- 1024-bit public key with Pkcs#1 Version 2.0 encryption.
- Support for encrypted multicast broadcasts, so that only authorized service flows receive a particular multicast broadcast.
- Secure software download allows a service provider to upgrade a cable modem's software remotely, without the risk of interception, interference, or alteration.

## Concatenation

Concatenation allows a cable modem to make a single time-slice request for multiple upstream packets, sending all of the packets in a single large burst on the upstream. Concatenation can send multiple upstream packets as part of one larger MAC data frame, allowing the cable modem to make only one time-slot request for the entire concatenated MAC frame, reducing the delay in transmitting the packets on the upstream channel. This avoids wasting upstream bandwidth when sending a number of very small packets, such as TCP acknowledgement packets.

## Dynamic MAC Messages

Dynamic Service MAC messages allow the cable modem to dynamically create service flows on demand. These messages are DOCSIS link layer equivalents of the higher layer messages that create, tear down, and modify a service flow.

The DOCSIS 1.1 dynamic services state machine supports the following messages:

- Dynamic Service Add (DSA)—This message is used to create a new service flow.
- Dynamic Service Change (DSC)—This message is used to change the attributes of an existing service flow.
- Dynamic Service Deletion (DSD)—This message is used to delete an existing service flow.



---

**Note** These messages are collectively known as DSX messages.

---



## Enhanced Quality of Service

DOCSIS 1.1 provides enhanced quality of service (QoS) capabilities to give priority for real-time traffic such as voice and video:

- The DOCSIS 1.0 QoS model (a service ID (SID) associated with a QoS profile) has been replaced with a service flow and service class model that allows greater flexibility in assigning QoS parameters to different types of traffic and in responding to changing bandwidth conditions.
- Support for multiple service flows per cable modem allows a single cable modem to support a combination of data, voice, and video traffic.
- Greater granularity in QoS per cable modem in either direction, using unidirectional service flows.
- Upstream service flows can be assigned one of the following QoS scheduling types, depending on the type of traffic and application being used:
  - Best-effort—Data traffic sent on a non-guaranteed best-effort basis. This type of service flow is similar to the method used in DOCSIS 1.0 networks.
  - Real-time polling (rtPS)—Real-time service flows, such as video, that produce unicast, variable size packets at fixed intervals.
  - Non-real-time polling service (nrtPS)—Similar to the rtPS type, in that the cable modem is guaranteed regular opportunities to request data bursts of varying length, except that the CMTS can vary the time between its polling of the cable modem depending on the amount of traffic and congestion on the network.
  - Unsolicited grants (UGS)—Constant bit rate (CBR) or committed information rate (CIR) traffic, such as voice, that is characterized by fixed-size packets at fixed intervals, providing a guaranteed minimum data rate.
  - Unsolicited grants with activity detection (USG-AD)—Combination of UGS and rtPS, to accommodate real-time traffic that might have periods of inactivity (such as voice using silence suppression). The service flow uses UGS fixed grants while active, but switches to rtPS polling during periods of inactivity to avoid wasting unused bandwidth.

## Fragmentation

DOCSIS fragmentation allows the upstream MAC scheduler to slice large data requests to fit into the scheduling gaps between UGS (voice slots). This prevents large data packets from affecting real-time traffic, such as voice and video.

Fragmentation reduces the run-time jitter experienced by the UGS slots when large data grants preempt the UGS slots. Disabling fragmentation increases the run-time jitter, but also reduces the fragmentation reassembly overhead for fragmented MAC frames.



---

**Note** DOCSIS fragmentation should not be confused with the fragmentation of IP packets, which is done to fit the packets on network segments with smaller maximum transmission unit (MTU) size. DOCSIS Fragmentation is Layer 2 fragmentation that is primarily concerned with efficiently transmitting lower-priority packets without interfering with high-priority real-time traffic, such as voice calls. IP fragmentation is done at Layer 3 and is primarily intended to accommodate routers that use different maximum packet sizes.

---

## Interoperability

DOCSIS 1.1 cable modems can coexist with DOCSIS 1.0 and 1.0+ cable modems in the same network. The Cisco CMTS provides the levels of service that are appropriate for each cable modem.

## Payload Header Suppression

Payload header suppression (PHS) conserves link-layer bandwidth by suppressing repetitive or redundant packet headers on both upstream and downstream service flows. PHS is enabled or disabled per service flow, and each service flow can support a separate set of PHS rules that determine which parts of the header are suppressed. This ensures that PHS is done in the most efficient manner for each service flow and its particular type of application.

## Downstream ToS Overwrite

Downstream ToS Overwrite is supported in DOCSIS 1.1. It can be used in IPv4 and IPv6 environment. You can use CLI command **cable service class *class-index tos-overwrite and-mask or-mask*** or the cable modem configuration file to configure downstream ToS overwrite.

To display the ToS value, use the **show cable modem qos verbose** command as shown in the following example:

```
Router# show cable modem 30.140.0.41 qos verbose
Load for five secs: 5%/0%; one minute: 4%; five minutes: 4%
Time source is NTP, 15:22:46.911 CST Wed Apr 25 2018
```

```
Sfid: 29
Current State: Active
Sid: 8
Service Class Name:
Traffic Priority: 0
Maximum Sustained rate: 0 bits/sec
Maximum Burst: 3044 bytes
Minimum Reserved rate: 0 bits/sec
Minimum Packet Size: 0 bytes
Admitted QoS Timeout: 200 seconds
Active QoS Timeout: 0 seconds
Maximum Concatenated Burst: 1522 bytes
Scheduling Type: Best Effort
Request/Transmission policy: 0x0
IP ToS Overwrite[AND-mask, OR-mask]: 0xFF, 0x0
Peak Rate: 0 bits/sec
Current Throughput: 545 bits/sec, 0 packets/sec
```

```
Sfid: 30
Current State: Active
Sid: N/A
Low Latency App: No
Service Class Name:
Traffic Priority: 0
Maximum Sustained rate: 0 bits/sec
Maximum Burst: 3044 bytes
Minimum Reserved rate: 0 bits/sec
Minimum Packet Size: 0 bytes
Admitted QoS Timeout: 200 seconds
Active QoS Timeout: 0 seconds
Maximum Latency: 0 usecs
IP ToS Overwrite[AND-mask, OR-mask]: 0xFF, 0x0
```

Peak Rate: 0 bits/sec  
Current Throughput: 446 bits/sec, 0 packets/sec

## DOCSIS 1.1 Quality of Service

The DOCSIS 1.1 QoS framework is based on the following objects:

- Service flow—A unidirectional sequence of packets on the DOCSIS link. Separate service flows are used for upstream and downstream traffic, and define the QoS parameters for that traffic.
- Service class—A collection of settings maintained by the CMTS that provide a specific QoS service tier to a cable modem that has been assigned a service flow associated with that service class.
- Packet classifier—A set of packet header fields used to classify packets onto a service flow to which the classifier belongs. The CMTS uses the packet classifiers to match the packet to the appropriate service flow.
- Payload header suppression (PHS) rule—A set of packet header fields that are suppressed by the sending entity before transmitting on the link, and are restored by the receiving entity after receiving a header-suppressed frame transmission. PHS increases the bandwidth efficiency by removing repeated packet headers before transmission.

See the following sections for more information on these components.

### Service Flow

In DOCSIS 1.1, the basic unit of QoS is the service flow, which is a unidirectional sequence of packets transported across the RF interface between the cable modem and CMTS. A service flow defines a set of QoS parameters such as latency, jitter, and throughput assurances, and these parameters can be applied independently to the upstream and downstream traffic flows. This is a major difference from DOCSIS 1.0 networks, where the same QoS parameters were applied to both the downstream and upstream flows.



---

**Note** DOCSIS 1.0 networks used service IDs (SIDs) to identify the QoS parameter set for a particular flow. DOCSIS 1.1 networks use the service flow ID (SFID) to identify the service flows that have been assigned to a particular upstream or downstream. DOCSIS 1.1 networks still use the term SID, but it applies exclusively to upstream service flows.

---

Every cable modem establishes primary service flows for the upstream and downstream directions, with a separate SFID for the upstream and the downstream flows. The primary flows maintain connectivity between the cable modem and CMTS, allowing the CMTS to send MAC management messages at all times to the cable modem.

In addition, a DOCSIS 1.1 cable modem can establish multiple secondary service flows. The secondary service flows either can be permanently created (by configuring them in the DOCSIS configuration file that is downloaded to the cable modem), or the service flows can be created dynamically to meet the needs of the on-demand traffic, such as voice calls. Permanent service flows remain in effect, even if they are not being used, while dynamic service flows are deleted when they are no longer needed.

At any given time, a service flow might be in one of three states (provisioned, admitted, or active). Only active flows are allowed to pass traffic on the DOCSIS network. Every service flow is identified by an SFID, while upstream service flows in the admitted and active state have an extra Layer 2 SID associated with them. The SID is the identifier used by the MAC scheduler when specifying time-slot scheduling for different service flows.

## Service Class

Each service flow is associated with a service class, which defines a particular class of service and its QoS characteristics, such as the maximum bandwidth for the service flow and the priority of its traffic. The service class attributes can be inherited from a preconfigured CMTS local service class (class-based flows), or they can be individually specified when a cable modem dynamically requests a service flow and the CMTS creates it.

The DOCSIS 1.1 service class also defines the MAC-layer scheduling type for the service flow. The schedule type defines the type of data burst requests that the cable modem can make, and how often it can make those requests. The following types of schedule types are supported:

- **Best-effort (BE)**—A cable modem competes with the other cable modems in making bandwidth requests and must wait for the CMTS to grant those requests before transmitting data. This type of service flow is similar to the method used in DOCSIS 1.0 networks.
- **Real-time polling service (rtPS)**—A cable modem is given a periodic time slot in which it can make bandwidth requests without competing with other cable modems. This allows real-time transmissions with data bursts of varying length.
- **Non-real-time polling service (nrtPS)**—A cable modem is given regular opportunities to make bandwidth requests for data bursts of varying size. This type of flow is similar to the rtPS type, in that the cable modem is guaranteed regular opportunities to request data bursts of varying length, except that the CMTS can vary the time between its polling of the cable modem, depending on the amount of traffic and congestion on the network.
- **Unsolicited grant service (UGS)**—A cable modem can transmit fixed data bursts at a guaranteed minimum data rate and with a guaranteed maximum level of jitter. This type of service flow is suitable for traffic that requires a Committed Information Rate (CIR), such as Voice-over-IP (VoIP) calls.
- **Unsolicited grant service with activity detection (UGS-AD)**—Similar to the UGS type, except that the CMTS monitors the traffic to detect when the cable modem is not using the service flow (such as voice calls when nobody is speaking). When the CMTS detects silence on the service flow, the CMTS temporarily switches the service flow to an rtPS type. When the cable modem begins using the flow again, the CMTS switches the flow back to the UGS type. This allows the CMTS to more efficiently support VoIP calls.

Each service flow is assigned a single service class, but the same service class can be assigned to multiple service flows. Also, a cable modem can be assigned multiple service flows, allowing it to have multiple traffic flows that use different service classes.

## Packet Classifiers

In DOCSIS 1.0 networks, a cable modem used only one set of QoS parameters for all of its traffic, so the CMTS simply had to route packets to and from the appropriate cable modems. In DOCSIS 1.1 networks, however, cable modems can be using multiple service flows, and each service flow can be given a different level of service. To quickly assign upstream and downstream packets to their proper service flows, the CMTS uses the concept of packet classifiers.

Each packet classifier specifies one or more packet header attributes, such as source MAC address, destination IP address, or protocol type. The classifier also specifies the service flow to be used when a packet matches this particular combination of headers. Separate classifiers are used for downstream and upstream service flows.

When the CMTS receives downstream and upstream packets, it compares each packet's headers to the contents of each packet classifier. When the CMTS matches the packet to a classifier, the CMTS then assigns the proper SFID to the packet and transmits the packet to or from the cable modem. This ensures that the packet is assigned its proper service flow, and thus its proper QoS parameters.

Figure below illustrates the mapping of packet classifiers.

**Figure 37: Classification Within the MAC Layer**

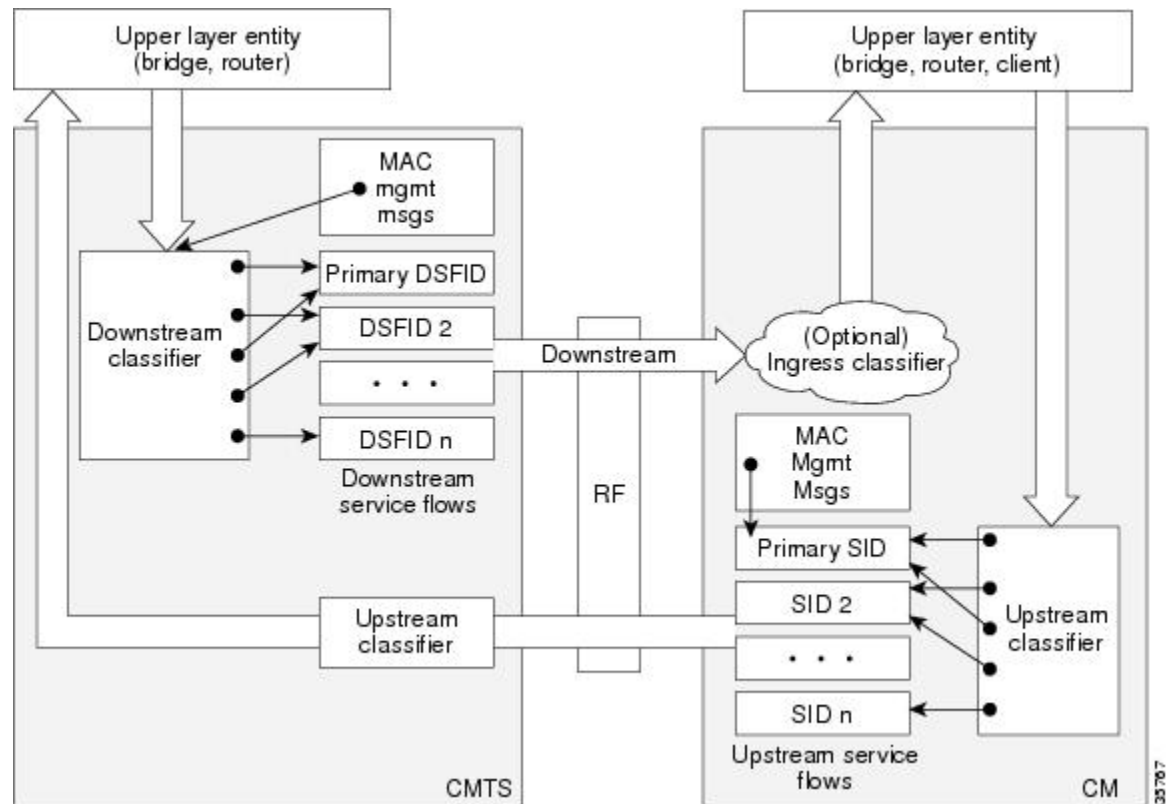

## Packet Header Suppression Rules

Because many data and real-time applications may use fixed values in their packet header fields, DOCSIS 1.1 supports PHS to suppress the duplicate portions of the packet headers when a group of packets is transmitted during a session. Each service flow can support a separate set of PHS rules that determine which parts of the header are suppressed.

When PHS is being used, the transmitting CMTS suppresses the specified headers in all the packets for that service flow. The receiving CMTS then restores the missing headers before forwarding the packets on to their ultimate destination.

Proper use of PHS can increase the efficiency of packetized transmissions, especially for real-time data that is encapsulated by other protocols, such as VoIP traffic.

## Quality of Service Comparison

This section summarizes the differences in QoS between DOCSIS 1.0, DOCSIS 1.0+, and DOCSIS 1.1 networks.



---

**Note** Cisco CMTS routers can transparently interoperate with cable modems running DOCSIS 1.0, DOCSIS 1.0+ extensions, or DOCSIS 1.1. If a cable modem indicates at system initialization that it is DOCSIS 1.1-capable, the Cisco CMTS router uses the DOCSIS 1.1 features. If the cable modem is not DOCSIS 1.1-capable, but does support the DOCSIS 1.0+ QoS extensions, the Cisco CMTS automatically supports the cable modem's requests for dynamic services. Otherwise, the cable modem is treated as a DOCSIS 1.0 device.

---

## DOCSIS 1.0

DOCSIS 1.0 uses a static QoS model that is based on a class of service (CoS) that is preprovisioned in the DOCSIS configuration file that is downloaded to the cable modem. The CoS is a bidirectional QoS profile that applies to both the upstream and downstream directions, and that has limited control, such as peak rate limits in either direction, and relative priority on the upstream.

DOCSIS 1.0 defines the concept of a service identifier (SID), which identifies the cable modems that are allowed to transmit on the network. In DOCSIS 1.0 networks, each cable modem is assigned only one SID for both the upstream and downstream directions, creating a one-to-one correspondence between a cable modem and its SID. All traffic originating from, or destined for, a cable modem is mapped to that particular SID.

Typically, a DOCSIS 1.0 cable modem has one CoS and treats all traffic the same, which means that data traffic on a cable modem can interfere with the quality of a voice call in progress. The CMTS, however, has a limited ability to prioritize downstream traffic based on IP precedence type-of-service (ToS) bits.

For example, voice calls using higher IP precedence bits receive a higher queueing priority (but without a guaranteed bandwidth or rate of service). A DOCSIS 1.0 cable modem could increase voice call quality by permanently reserving bandwidth for voice calls, but then that bandwidth would be wasted whenever a voice call is not in progress.

## DOCSIS 1.0+

In response to the limitations of DOCSIS 1.0 networks in handling real-time traffic, such as voice calls, Cisco created the DOCSIS 1.0+ extensions to provide the more important QoS enhancements that were expected in DOCSIS 1.1. In particular, the DOCSIS 1.0+ enhancements provide basic Voice-over-IP (VoIP) service over the DOCSIS link.

Cisco's DOCSIS 1.0+ extensions include the following DOCSIS 1.1 features:

- Multiple SIDs per cable modem, creating separate service flows for voice and data traffic. This allows the CMTS and cable modem to give higher priority for voice traffic, preventing the data traffic from affecting the quality of the voice calls.
- Cable modem-initiated dynamic MAC messages—Dynamic Service Addition (DSA) and Dynamic Service Deletion (DSD). These messages allow dynamic SIDs to be created and deleted on demand, so that the bandwidth required for a voice call can be allocated at the time a call is placed and then freed up for other uses when the call is over.
- Unsolicited grant service (CBR-scheduling) on the upstream—This helps provide a higher-quality channel for upstream VoIP packets from an Integrated Telephony Cable Modem (ITCM) such as the Cisco uBR925 cable access router.
- Ability to provide separate downstream rates for any given cable modem, based on the IP-precedence value in the packet. This helps separate voice signaling and data traffic that goes to the same ITCM to address rate shaping purposes.

- Concatenation allows a cable modem to send several packets in one large burst, instead of having to make a separate grant request for each.



**Caution** All DOCSIS 1.0 extensions are available only when using a cable modem and CMTS that supports these extensions. The cable modem activates the use of the extensions by sending a dynamic MAC message. DOCSIS 1.0 cable modems continue to receive DOCSIS 1.0 treatment from the CMTS.

## Interoperability with Different Versions of DOCSIS Networks

DOCSIS 1.1 cable modems have additional features and better performance than earlier DOCSIS 1.0 and 1.0+ models, but all three models can coexist in the same network. DOCSIS 1.0 and 1.0+ cable modems will not hamper the performance of a DOCSIS 1.1 CMTS, nor will they interfere with operation of DOCSIS 1.1 features.

Table below shows the interoperability of a DOCSIS 1.1 CMTS with different versions of cable modems.

**Table 285: DOCSIS 1.1 Interoperability**

| For this configuration...                     | The result is...                                                                                                                                                                                                                                                                                                                                                                                                                                                                                                                                                     |
|-----------------------------------------------|----------------------------------------------------------------------------------------------------------------------------------------------------------------------------------------------------------------------------------------------------------------------------------------------------------------------------------------------------------------------------------------------------------------------------------------------------------------------------------------------------------------------------------------------------------------------|
| DOCSIS 1.1 CMTS with DOCSIS 1.0 cable modems  | DOCSIS 1.0 cable modems receive DOCSIS 1.0 features and capabilities. BPI is supported if available and enabled on the CMTS.                                                                                                                                                                                                                                                                                                                                                                                                                                         |
| DOCSIS 1.1 CMTS with DOCSIS 1.0+ cable modems | DOCSIS 1.0+ cable modems receive basic DOCSIS 1.0 support. BPI is supported if available and enabled on the CMTS. In addition, DOCSIS 1.0+ cable modems also receive the following DOCSIS 1.1 features: <ul style="list-style-type: none"> <li>• Multiple SIDs per cable modem</li> <li>• Dynamic service MAC messaging initiated by the cable modem</li> <li>• Unsolicited grant service (UGS, CBR-scheduling) on the upstream</li> <li>• Separate downstream rates for any given cable modem, based on the IP-precedence value</li> <li>• Concatenation</li> </ul> |
| DOCSIS 1.1 CMTS with DOCSIS 1.1 cable modems  | DOCSIS 1.1 cable modems receive all the DOCSIS 1.1 features listed in this document. BPI+ is supported if available and enabled on the CMTS.                                                                                                                                                                                                                                                                                                                                                                                                                         |

## Enhanced Rate Bandwidth Allocation (ERBA) Support for DOCSIS 1.0 Cable Modems

To define ERBA on the downstream for DOCSIS 1.0 cable modems, use the cable qos promax-ds-burst command in global configuration mode.

The ERBA feature is characterized by the following enhancements:

- Enables support for the DOCSIS1.1 Downstream Maximum Transmit Burst parameter on the Cisco CMTS by using the **cable ds-max-burst** configuration command.
- Allows DOCSIS1.0 modems to support the DOCSIS1.1 Downstream Maximum Transmit Burst parameter by mapping DOCSIS1.0 modems to overriding DOCSIS 1.1 QoS profile parameters on the Cisco CMTS.

ERBA allows DOCSIS 1.0 modems to burst their temporary transmission rate up to the full line rate for short durations of time. This capability provides higher bandwidth for instantaneous bandwidth requests, such as those in Internet downloads, without having to make changes to existing service levels in the QoS Profile.

This feature allows you to set the DOCSIS 1.0 cable modems burst transmissions, with mapping to overriding DOCSIS 1.1 QoS profile parameters on the Cisco CMTS. DOCSIS 1.0 cable modems require DOCSIS 1.0 parameters when registering to a matching QoS profile. This feature enables maximum downstream line rates, and the ERBA setting applies to all cable modems that register to the corresponding QoS profile.



---

**Note** QoS definitions must previously exist on the Cisco CMTS headend to support this feature.

---

ERBA for DOCSIS 1.0 cable modems is supported with these new or enhanced commands or keywords:

- cable qos pro max-ds-burst burst-size
- show cable qos profile n [verbose]

## DOCSIS 3.0 Downstream Peak Traffic Rate TLV Support for ERBA

The DOCSIS WFQ Scheduler allows each service flow to have one dedicated queue. When ERBA is enabled for the service flow, the peak rate is implemented as the queue shape rate within the scheduler, while the maximum sustained rate is set as the token bucket refill rate. When ERBA is turned off, the burst size and the peak rate value are not used.

The maximum traffic burst parameter is used to control a service flow burst duration, to burst up to the channel line rate or a configured peak rate, when it is within its maximum burst size allowance. On the Cisco cBR-8 Converged Broadband Router, the **cable ds-max-burst** command is used to control this behavior explicitly.

The *peak-rate* keyword is introduced to specify the peak rate an ERBA-enabled service flow can use. The peak rate value is applied to a specific service flow created after the configuration of the **cable ds-max-burst** command.

If the DOCSIS 3.0 TLV 25.27 is specified for a service flow, the *peak rate* value is set as the TLV value. However, if ERBA is not turned on for a service flow, the *peak rate* value is ignored.

During modem registration or Dynamic Service Addition (DSA) operation, the service class name TLV 25.4 is sent to create the static or dynamic downstream service flow that matches the service class template. These downstream service flows are created with a specific *peak rate*.

Some of the DOCSIS 1.x and DOCSIS 2.0 cable modems, which are not fully DOCSIS 1.x or DOCSIS 2.0 compliant, may fail to come online when the downstream peak rate TLV 25.27 is received from the CMTS during registration. To overcome this failure, you can configure the cable service attribute withhold-TLVs command to restrict sending of the peak traffic rate TLVs to DOCSIS 1.x and DOCSIS 2.0 cable modems. For more information on how to suppress peak rate TLVs, see [Suppressing Upstream and Downstream Peak Rate TLVs for pre DOCSIS 3.0 Cable Modems, on page 1437](#).



---

**Note** The ERBA feature is not applicable for high priority service flows and multicast service flows.

---

Table below summarizes the ERBA support for the Cisco cBR-8 router.



**Table 286: Enhanced Rate Bandwidth Allocation Support for the Cisco cBR-8 Router**

|                           | <b>Policer Rate</b>                     | <b>Policer Exceed Action</b> | <b>Policer Token Bucket Size</b>             | <b>Queue Shape Rate</b>        |
|---------------------------|-----------------------------------------|------------------------------|----------------------------------------------|--------------------------------|
| Traditional Service Flow  | Maximum Sustained Traffic Rate (unused) | Transmit                     | A value computed internally by CMTS (unused) | Maximum Sustained Traffic Rate |
| ERBA-Enabled Service Flow | Maximum Sustained Traffic Rate          | Drop                         | Maximum Traffic Burst TLV                    | Peak Traffic Rate              |

In Cisco cBR-8 routers, the dual token bucket-based shaper is used to support ERBA on the Cisco cBR-8 CCAP line card (the ERBA feature is always enabled on the Cisco cBR-8 CCAP line card). The dual token bucket shaper has two independent token buckets for each service flow. The maximum rate of one bucket is configured to MSR and the maximum tokens are set to maximum traffic burst. The other bucket is configured with the refilling rate of the *peak rate* and the maximum tokens are set to the default level of 4 milliseconds. Packets are shaped if any of the two buckets are exhausted.

Table below summarizes the ERBA dual token bucket configuration for the Cisco cBR-8 routers.

**Table 287: ERBA Dual Token Bucket Configuration**

|                           | <b>Token Bucket Rate (One)</b> | <b>Token Bucket Size (One)</b>     | <b>Token Bucket Rate (Two)</b> | <b>Token Bucket Size (Two)</b> |
|---------------------------|--------------------------------|------------------------------------|--------------------------------|--------------------------------|
| Traditional Service Flow  | Maximum Sustained Traffic Rate | 4ms * MSR                          | N/A                            | N/A                            |
| ERBA-enabled Service Flow | Maximum Sustained Traffic Rate | Maximum Traffic Burst or 4ms * MSR | Peak Rate                      | 4ms * Peak Rate                |

## Suppressing Upstream and Downstream Peak Rate TLVs for pre DOCSIS 3.0 Cable Modems

The DOCSIS 3.0 upstream (US) peak rate TLV 24.27 and downstream (DS) peak rate TLV 25.27 are enabled on the Cisco CMTS through the cable service class command or the CM configuration file. The DOCSIS 1.x and DOCSIS 2.0 CMs do not support these TLVs. Ideally, if a DOCSIS 1.x or DOCSIS 2.0 CM receives peak rate TLVs during registration, it should ignore these TLVs and proceed with the registration. However there are a few old non-compliant pre DOCSIS 3.0 CMs, which may fail to come online when peak-rate TLVs are received in the registration response from the Cisco CMTS. To overcome this, the Cisco CMTS enables suppression of the DOCSIS 3.0 peak rate TLVs for the pre-DOCSIS3.0 CMs.

To suppress the DOCSIS 3.0 US and DS peak rate TLVs, use the **cable service attribute withhold-TLVs command with the peak-rate** keyword in global configuration mode. When configured, this command restricts the Cisco CMTS from sending US and DS peak rate TLVs to the DOCSIS 1.x and DOCSIS 2.0 CMs. The decision to send the TLVs is based on the DOCSIS version of the CM received during registration. If the registration request is from a pre DOCSIS 3.0 CM, the peak rate TLVs are not sent in the registration response. However this command does not restrict sending of DOCSIS 3.0 peak-rate TLVs to DOCSIS 3.0 CMs.

## Downstream Classification Enhancement with MAC Addresses

Downstream classifiers, specified in the cable modem configuration file, are used to map packets to service flows based on DOCSIS specifications. New combinations of downstream classifiers with a destination MAC address are supported. This enhancement enables service providers to better manage high priority service flows associated with a downstream classifier. For example, a single User Datagram Protocol (UDP) port can be shared by high priority and low priority traffic.

Downstream classification is automatically enabled on the Cisco CMTS router. The downstream classifier combinations that are supported on the router are listed below:

Without Combination

- IP (IPv4)
- IPv6
- TCP/UDP
- Destination MAC

With Combination

- IPv4 + TCP/UDP
- IPv6 + TCP/UDP
- Destination MAC + IPv4 (with the exception of a destination IP address)
- Destination MAC + IPv6 (with the exception of a destination IPv6 address)
- Destination MAC + TCP/UDP
- Destination MAC + IPv4 + TCP/UDP (with the exception of a destination IP address)
- Destination MAC + IPv6 + TCP/UDP (with the exception of a destination IPv6 address)

## Benefits

DOCSIS 1.1 includes a rich set of features that provide advanced and flexible QoS capabilities for various types of traffic (voice, data, and video) over the cable network. It also provides enhanced security and authentication features.

### Baseline Privacy Interface Plus Enhancement

The Plus (+) version of the Baseline Privacy Interface (BPI+) in DOCSIS 1.1 provides a set of extended services within the MAC sublayer that increase performance and system security. Digital certificates provide secure authentication for each cable modem, to prevent identity theft on the basis of MAC and IP addresses. Advanced encryption provides a secure channel between the cable modem and CMTS, and secure software download allows a service provider to upgrade the software on cable modems, without the threat of interception, interference, or alteration of the software code.

### Dynamic Service Flows

The dynamic creation, modification, and deletion of service flows allows for on-demand reservation on Layer 2 bandwidth resources. The CMTS can now provide special QoS to the cable modem dynamically for the duration of a voice call or video session, as opposed to the static provisioning and reservation of resources at the time of cable modem registration. This provides a more efficient use of the available bandwidth.

### Concatenation

The cable modem concatenates multiple upstream packets into one larger MAC data frame, allowing the cable modem to make only one time-slot request for the entire concatenated MAC frame, as opposed to requesting a time slot for each packet. This reduces the delay in transferring the packet burst upstream.

### Enhanced QoS

Extensive scheduling parameters allow the CMTS and the cable modem to communicate QoS requirements and achieve more sophisticated QoS on a per service-flow level.

Different new time-slot scheduling disciplines help in providing guaranteed delay and jitter bound on shared upstream. Activity detection helps to conserve link bandwidth by not issuing time slots for an inactive service flow. The conserved bandwidth can then be reused for other best-effort data slots.

Packet classification helps the CMTS and cable modem to isolate different types of traffic into different DOCSIS service flows. Each flow could be receiving a different QoS service from CMTS.

### Fragmentation

Fragmentation splits large data packets so that they fit into the smaller time slots inbetween UGS slots. This reduces the jitter experienced by voice packets when large data packets are transmitted on the shared upstream channel and preempt the UGS slots used for voice.

### Multiple Subflows per SID

This feature allows the cable modem to have multiple calls on a single hardware queue. This approach scales much better than requiring a separate SID hardware queue on the cable modem for each voice call.

### Payload Header Suppression

Payload Header Suppression (PHS) allows the CMTS and cable modem to suppress repetitive or redundant portions in packet headers before transmitting on the DOCSIS link. This conserves link bandwidth, especially with types of traffic such as voice, where the header size tends to be as large as the size of the actual packet.

### Service Classes

The use of the service class provides the following benefits for a DOCSIS 1.1 network:

- It allows operators to move the burden of configuring service flows from the provisioning server to the CMTS. Operators provision the modems with the service class name; the implementation of the name is configured at the CMTS. This allows operators to modify the implementation of a given service to local circumstances without changing modem provisioning. For example, some scheduling parameters might need to be set differently for two different CMTSs to provide the same service. As another example, service profiles could be changed by time of day.
- It allows CMTS vendors to provide class-based-queuing if they choose, where service flows compete within their class and classes compete with each other for bandwidth.
- It allows higher-layer protocols to create a service flow by its service class name. For example, telephony signaling might direct the cable modem to instantiate any available provisioned service flow of class G.711.



---

**Note** The service class is optional. The flow scheduling specification may always be provided in full; a service flow may belong to no service class whatsoever. CMTS implementations *may* treat such unclassified flows differently from classed flows with equivalent parameters.

---

## How to Configure the Cisco CMTS for DOCSIS 1.1 Operations

See the following sections for the configuration tasks for DOCSIS 1.1 operations. Each task in the list is identified as either required or optional.



---

**Note** This section describes only the configuration tasks that are specific for DOCSIS 1.1 operations.

---

## Configuring Baseline Privacy Interface

BPI+ encryption is by default enabled for 56-bit DES encryption on all cable interfaces. If BPI+ encryption has been previously disabled, or if you want to reconfigure BPI+ encryption on a cable interface on the CMTS, use the following procedure.



---

**Note** If you have disabled BPI+ encryption on a cable interface, and a cable modem attempts to register on that interface using BPI+ encryption, the CMTS will reject its registration request, displaying a %CBR-4-SERVICE\_PERMANENTLY\_UNAVAILABLE error message. The **show cable modem** command will also show that this cable modem has been rejected with a MAC status of reject(c).

---

### Before you begin

BPI+ encryption is supported on all Cisco CMTS images that include “k1”, “k8”, or “k9” in its file name or BPI in the feature set description. All BPI images support 40-bit and 56-bit DES encryption.

By default, BPI+ encryption is enabled for 56-bit DES encryption. Also, when a cable modem is running DOCSIS 1.1 software, BPI+ encryption is enabled by default, unless the service provider has disabled it by setting the Privacy Enable field (TLV 29) in the DOCSIS configuration file to 0. Therefore, both the CMTS and cable modem are set to use BPI+ encryption when using the default configurations.

### Procedure

|        | Command or Action                                                        | Purpose                                                        |
|--------|--------------------------------------------------------------------------|----------------------------------------------------------------|
| Step 1 | <b>enable</b><br><b>Example:</b><br><pre>Router&gt; enable Router#</pre> | Enables privileged EXEC mode. Enter your password if prompted. |

|        | Command or Action                                                                                                                                                               | Purpose                                                                                                                                                                                                                                                                                                                                                                                                                                                                                                                                                                                                                                                                                                                                                                                                                                              |
|--------|---------------------------------------------------------------------------------------------------------------------------------------------------------------------------------|------------------------------------------------------------------------------------------------------------------------------------------------------------------------------------------------------------------------------------------------------------------------------------------------------------------------------------------------------------------------------------------------------------------------------------------------------------------------------------------------------------------------------------------------------------------------------------------------------------------------------------------------------------------------------------------------------------------------------------------------------------------------------------------------------------------------------------------------------|
| Step 2 | <p><b>configure terminal</b></p> <p><b>Example:</b></p> <pre>Router# configure terminal Router(config)#</pre>                                                                   | Enters global configuration mode.                                                                                                                                                                                                                                                                                                                                                                                                                                                                                                                                                                                                                                                                                                                                                                                                                    |
| Step 3 | <p><b>interface cableslot /subslot /port</b></p> <p><b>Example:</b></p> <pre>Router(config)# interface cable 6/0/0 Router(config-if)#</pre>                                     | Enters interface configuration mode for the cable interface line card at this particular slot.                                                                                                                                                                                                                                                                                                                                                                                                                                                                                                                                                                                                                                                                                                                                                       |
| Step 4 | <p><b>cable privacy</b></p> <p><b>Example:</b></p> <pre>Router(config-if)# cable privacy Router(config-if)#</pre>                                                               | (Optional) Enables BPI+ 56-bit DES encryption on the cable interface (default).                                                                                                                                                                                                                                                                                                                                                                                                                                                                                                                                                                                                                                                                                                                                                                      |
| Step 5 | <p><b>cable privacy accept-self-signed-certificate</b></p> <p><b>Example:</b></p> <pre>Router(config-if)# cable privacy accept-self-signed-certificate Router(config-if)#</pre> | <p>(Optional) Allows cable modems to register using self-signed manufacturer certificates, as opposed to the default of allowing only manufacturer's certificates that are chained to the DOCSIS root certificate.</p> <p><b>Caution</b> Use the above command sparingly, as it bypasses DOCSIS BPI+ certificates. Otherwise, self-signed certificates provide workaround registration for cable modems that are not compliant with DOCSIS BPI+ certificates. This functionality is strictly intended for troubleshooting of a short duration or in the context of additional security measures.</p> <p><b>Note</b> By default, the CMTS does not accept self-signed certificates. In the default configuration, if a cable modem attempts to register with self-signed certificates, the CMTS will refuse to allow the cable modem to register.</p> |
| Step 6 | <p><b>cable privacy authorize-multicast</b></p> <p><b>Example:</b></p> <pre>Router(config-if)# cable privacy authorize-multicast Router(config-if)#</pre>                       | <p>(Optional) Enables BPI+ encryption on the cable interface and uses AAA protocols to authorize all multicast stream (IGMP) join requests.</p> <p><b>Note</b> If you use this command to authorize multicast streams, you must also use the <b>cable privacy authenticate-modem</b> command to enable AAA services on the cable interface.</p>                                                                                                                                                                                                                                                                                                                                                                                                                                                                                                      |

|                | Command or Action                                                                                                                                      | Purpose                                                                                                                                                                                                                                                                              |
|----------------|--------------------------------------------------------------------------------------------------------------------------------------------------------|--------------------------------------------------------------------------------------------------------------------------------------------------------------------------------------------------------------------------------------------------------------------------------------|
| <b>Step 7</b>  | <b>cable privacy mandatory</b><br><b>Example:</b><br><pre>Router(config-if)# cable privacy mandatory Router(config-if)#</pre>                          | (Optional) Requires baseline privacy be active for all CMs with BPI/BPI+ enabled in the DOCSIS configuration files, else the CMs are forced to go offline.<br><br>If a CM does not have BPI enabled in its DOCSIS configuration file, it will be allowed to come online without BPI. |
| <b>Step 8</b>  | <b>cable privacy oaep-support</b><br><b>Example:</b><br><pre>Router(config-if)# cable privacy oaep-support Router(config-if)#</pre>                    | (Optional) Enables BPI+ encryption on the cable interface and enables Optimal Asymmetric Encryption Padding (OAEP). This option is enabled by default. Disabling this option could have a performance impact.                                                                        |
| <b>Step 9</b>  | <b>cable privacy kek {life-time seconds}</b><br><b>Example:</b><br><pre>Router(config-if)# cable privacy kek life-time 302400 Router(config-if)#</pre> | (Optional) Configures the life-time values for the key encryption keys (KEKs) for BPI+ operations on all cable interfaces.                                                                                                                                                           |
| <b>Step 10</b> | <b>cable privacy tek {life-time seconds}</b><br><b>Example:</b><br><pre>Router(config-if)# cable privacy tek life-time 86400 Router(config-if)#</pre>  | (Optional) Configures the life-time values for the traffic encryption keys (TEKs) for BPI+ operations on all cable interfaces.                                                                                                                                                       |
| <b>Step 11</b> | <b>exit</b><br><b>Example:</b><br><pre>Router(config-if)# exit Router(config)#</pre>                                                                   | Exits interface configuration mode.<br><br><b>Note</b> Repeat steps <a href="#">Step 3, on page 1441</a> through <a href="#">Step 11, on page 1442</a> for each cable interface.                                                                                                     |
| <b>Step 12</b> | <b>exit</b><br><b>Example:</b><br><pre>Router(config)# exit Router#</pre>                                                                              | Exits global configuration mode.                                                                                                                                                                                                                                                     |

### What to do next

You can also configure the following additional timers for BPI+ operations in the DOCSIS configuration file for each cable modem. As a general rule, you do not need to specify these timers in the DOCSIS configuration file unless you have a specific reason for changing them from their default values.

Table 288: Individual Cable Modem BPI+ Timer Values

| Timer                         | Description                                                                                                                                                       |
|-------------------------------|-------------------------------------------------------------------------------------------------------------------------------------------------------------------|
| Authorize Wait Timeout        | The amount of time a cable modem will wait for a response from a CMTS when negotiating a KEK for the first time.                                                  |
| Reauthorize Wait Timeout      | The amount of time a cable modem will wait for a response from a CMTS when negotiating a new KEK because the Authorization Key (KEK) lifetime is about to expire. |
| Authorize Reject Wait Timeout | The amount of time a cable modem must wait before attempting to negotiate a new KEK if the CMTS rejects its first attempt to negotiate a KEK.                     |
| Operational Wait Timeout      | The amount of time a cable modem will wait for a response from a CMTS when negotiating a TEK for the first time.                                                  |
| Rekey Wait Timeout            | The amount of time a cable modem will wait for a response from a CMTS when negotiating a new TEK because the TEK lifetime is about to expire.                     |

## Downloading the DOCSIS Root Certificate to the CMTS

DOCSIS 1.1 allows cable modems to identify themselves using a manufacturer's chained X.509 digital certificate that is chained to the DOCSIS root certificate. The DOCSIS root certificate is already installed on the bootflash of the CMTS router. However, if you want to install another root certificate, for example, the Euro-DOCSIS certificate, download the certificate and save it on the bootflash as "euro-root-cert".



**Tip** For more information about the DOCSIS root certificate provided by Verisign, see the information at the following URL: <http://www.verisign.com/products-services/index.html>



**Note** You may load the DOCSIS root certificate and a EuroDOCSIS or PacketCable root certificate. Cisco recommends that the EuroDOCSIS PacketCable root certificates be copied into bootflash.

To download the DOCSIS root certificate to the Cisco CMTS, which is required if any cable modems on the network are using chained certificates, use the following procedure:

**Step 1** Download the DOCSIS root certificate from the DOCSIS certificate signer, Verisign. At the time of this document's printing, the DOCSIS root certificate is available for download at the following URL:

<http://www.verisign.com/products-services/index.html>

**Step 2** Verisign distributes the DOCSIS root certificate in a compressed ZIP archive file. Extract the DOCSIS root certificate from the archive and copy the certificate to a TFTP server that the CMTS can access.

**Tip** To avoid possible confusion with other certificates, keep the file's original filename of "CableLabs\_DOCSIS.509" when saving it to the TFTP server.

**Step 3** Log in to the Cisco CMTS using either a serial port connection or a Telnet connection. Enter the **enable** command and password to enter Privileged EXEC mode:

**Example:**

```
Router> enable
Password: <password>
Router#
```

**Step 4** Use the **dir bootflash** command to verify that the bootflash has sufficient space for the DOCSIS root certificate (approximately 1,000 bytes of disk space):

**Example:**

```
Router# dir bootflash:
Directory of bootflash:/
 1  -rw-      3229188   Dec 30 2002 15:53:23  cbrsup-universalk9.2015-03-18_03.30_johuynh.SSA.bin
3407872 bytes total (250824 bytes free)
Router#
```

**Tip** If you delete files from the bootflash to make room for the DOCSIS root certificate, remember to use the **squeeze** command to reclaim the free space from the deleted files.

**Step 5** Use the **copy tftp bootflash** command to copy the DOCSIS root certificate to the router's bootflash memory. (The file must be named "root-cert" on the bootflash for the CMTS to recognize it as the root certificate.)

**Example:**

```
Router# copy tftp bootflash:
Address or name of remote host []? tftp-server-ip-address
Source filename []? CableLabs_DOCSIS.509
Destination filename [CableLabs_DOCSIS.509]? root-cert
Loading CableLabs_DOCSIS.509 from tftp-server-ip-address (via FastEthernet0/0): !
[OK - 996/1024 bytes]
996 bytes copied in 4.104 secs (249 bytes/sec)
Router#
```

**Tip** You can also copy the root certificate to a PCMCIA Flash Disk (disk0 or disk1). However, because Flash Disks are not secure and easily removed from the router, we recommend that you keep the root certificate in the bootflash for both operational and security reasons.

**Step 6** Verify that the DOCSIS root certificate has been successfully copied to the bootflash memory:

**Example:**

```
Router# dir bootflash:
Directory of bootflash:/
 1  -rw-      3229188   Dec 30 2002 15:53:23  cbrsup-universalk9.2015-03-18_03.30_johuynh.SSA.bin
 2  -rw-         996    Mar 06 2002 16:03:46  root-cert
3408876 bytes total (248696 zbytes free)
Router#
```



**Step 7** (Optional) After the first cable modem has registered using BPI+, you can use the **show crypto ca trustpoints** command to display the Root certificate that the CMTS has learned:

**Note** The **show crypto ca trustpoints** command does not display the root certificate until after at least one cable modem has registered with the CMTS using BPI+ encryption. Alternatively, you can use the unsupported command **test cable generate** in privileged EXEC mode to force the CMTS to register the root certificate.

**Example:**

```
Router# show crypto ca trustpoints
Root certificate
  Status: Available
  Certificate Serial Number: D54BB68FE934324F6B8FD0E41A65D867
  Key Usage: General Purpose
  Issuer:
    CN = DOCSIS Cable Modem Root Certificate Authority
    OU = Cable Modems
    O = Data Over Cable Service Interface Specifications
    C = US
  Subject Name:
    CN = "BPI Cable Modem Root Certificate Authority "
    OU = DOCSIS
    O = BPI
    C = US
  Validity Date:
    start date: 07:00:00 UTC Mar 27 2001
    end   date: 06:59:59 UTC Jan 1 2007
```

### What to do next



**Tip** To display all certificates (Root, Manufacturers, CM) that the CMTS has learned, use the **show crypto ca certificates** command.

## Adding a Manufacturer's Certificate as a Trusted Certificate

The DOCSIS specifications allow operators to control which manufacturer's and CM certificates are allowed on each CMTS by marking them as either trusted or untrusted. You can add a certificate to the list of trusted certificates on the Cisco CMTS using SNMP commands, as described in the following section:

### Adding a Certificate as a Trusted Certificate Using SNMP Commands

You can also use an SNMP manager to create and add certificates to the CMTS list of trusted certificates by manipulating the tables and attributes in the [DOCS-BPI-PLUS-MIB](#). To add a manufacturer's certificate, add an entry to the docsBpi2CmtsCACertTable table. Specify the following attributes for each entry:

- docsBpi2CmtsCACertStatus—Set to 4 to create the row entry.
- docsBpi2CmtsCACert—The hexadecimal data, as an X509Certificate value, for the actual X.509 certificate.
- docsBpi2CmtsCACertTrust—An Integer value from 1 to 4 specifying the certificate's trust status: 1=trusted, 2=untrusted, 3= chained, 4=root. Specify 1 for certificates that should be trusted and 3 for chained certificates that should be verified with the root certificate.

Similarly, to add a CM certificate to the list of trusted certificates, add an entry to the docsBpi2CmtsProvisionedCmCertTable table. Specify the following attributes for each entry:

- docsBpi2CmtsProvisionedCmCertStatus—Set to 4 to create the row entry.
- docsBpi2CmtsProvisionedCmCert—The hexadecimal data, as an X509Certificate value, for the actual X.509 certificate.
- docsBpi2CmtsProvisionedCmCertTrust—An Integer value from 1 to 2 specifying the certificate's trust status: 1=trusted, 2=untrusted. Specify 1 for CM certificates that should be trusted.



**Tip** Always set the CertStatus attributes before loading the actual certificate data, because otherwise the CMTS will assume the certificate is chained and will immediately attempt to verify it with the manufacturers and root certificates.

For example, to use the Unix command-line SNMP utility to add a manufacturer's certificate to the list of trusted certificates on the CMTS at IP address 192.168.100.134, enter the following command (be sure to substitute a valid index pointer for the table entry for the <index> value).

```
% setany -v2c 192.168.100.134 private docsBpi2CmtsCACertStatus.
<index>
-i 4
docsBpi2CmtsCACert.
<index>
-o
'<hex_data>' docsBpi2CmtsCACertTrust.
<index>
-i 1
```

To do the same thing for a CM certificate, use the following command:

```
% setany -v2c 192.168.100.134 private docsBpi2CmtsProvisionedCmCertStatus.
<index>
-i 4 docsBpi2CmtsProvisionedCmCert.
<index>
-o
'<hex_data>' docsBpi2CmtsProvisionedCmCertTrust.
<index>
-i 1
```



**Tip** Most operating systems cannot accept input lines that are as long as needed to input the hexadecimal decimal string that specifies a certificate. For this reason, you should use a graphical SNMP manager to set these attributes. For a number of certificates, you can also use a script file, if more convenient.



**Note** If you are adding self-signed certificates, you must also use the **cable privacy accept-self-signed-certificate** command before the CMTS will accept the certificates.

## Adding a Manufacturer's or CM Certificate to the Hotlist

The DOCSIS specifications allow operators to add a digital manufacturer's or CM certificate to a hotlist (also known as the certificate revocation list, or CRL) on the CMTS, to indicate that this particular certificate should no longer be accepted. This might be done when a user reports that their cable modem has been stolen, or when the service provider decides not to support a particular manufacturer's brand of cable modems.

### Adding a Certificate to the Hotlist Using SNMP Commands

You can also use an SNMP manager to create and add certificates to the hotlist by manipulating the tables and attributes in the [DOCS-BPI-PLUS-MIB](#). To add a manufacturer's certificate, add an entry to the docsBpi2CmtsCACertTable table. Specify the following attributes for each entry:

- docsBpi2CmtsCACertStatus—Set to 4 to create the row entry.
- docsBpi2CmtsCACert—The hexadecimal data, as an X509Certificate value, for the actual X.509 certificate.
- docsBpi2CmtsCACertTrust—An Integer value from 1 to 4 specifying the certificate's trust status: 1=trusted, 2=untrusted, 3= chained, 4=root. When adding a certificate to the hotlist, set this attribute to 2 for untrusted.

Similarly, to add a CM certificate to the hotlist, add an entry to the docsBpi2CmtsProvisionedCmCertTable table. Specify the following attributes for each entry:

- docsBpi2CmtsProvisionedCmCertStatus—Set to 4 to create the row entry.
- docsBpi2CmtsProvisionedCmCert—The hexadecimal data, as an X509Certificate value, for the actual X.509 certificate.
- docsBpi2CmtsProvisionedCmCertTrust—An Integer value from 1 to 2 specifying the certificate's trust status: 1=trusted, 2=untrusted. When adding a certificate to the hotlist, set this attribute to 2 for untrusted.



**Tip** Always set the CertStatus attributes before loading the actual certificate data, because otherwise the CMTS will assume the certificate is chained and will immediately attempt to verify it with the manufacturers and root certificates.



**Note** This procedure is identical to the one given for adding a certificate as a trusted certificate in the [Adding a Certificate as a Trusted Certificate Using SNMP Commands, on page 1445](#), except that the docsBpi2CmtsProvisionedCmCertTrust attribute is set to 2 instead of 1.

For example, to use the Unix command-line SNMP utility to add a manufacturer's certificate to the hotlist on the CMTS at IP address 192.168.100.113, enter the following command (be sure to substitute a valid index pointer for the table entry for the *<index>* value).

```
% setany -v2c 192.168.100.113 private docsBpi2CmtsCACertStatus.
<index>
-i 4
docsBpi2CmtsCACert.
<index>
-o
'<hex_data>' docsBpi2CmtsCACertTrust.
<index>
-i 2
```

To do the same thing for a CM certificate, use the following command:

```
% setany -v2c 192.168.100.113 private docsBpi2CmtsProvisionedCmCertStatus.
<index>
-i 4
docsBpi2CmtsProvisionedCmCert.
<index>
-o
'<hex_data>' docsBpi2CmtsProvisionedCmCertTrust.
<index>
-i 2
```



**Tip** Most operating systems cannot accept input lines that are as long as needed to input the hexadecimal decimal string that specifies a certificate. For this reason, you should use a graphical SNMP manager to set these attributes. For a number of certificates, you can also use a script file, if more convenient.

## Enabling Concatenation

To enable concatenation for one or more upstreams on a cable interface (which is the default configuration), use the following procedure:

### Procedure

|               | Command or Action                                                                                                                                                                                              | Purpose                                                                                                                                             |
|---------------|----------------------------------------------------------------------------------------------------------------------------------------------------------------------------------------------------------------|-----------------------------------------------------------------------------------------------------------------------------------------------------|
| <b>Step 1</b> | <b>enable</b><br><b>Example:</b><br><br>Router> enable<br>Router#                                                                                                                                              | Enables privileged EXEC mode. Enter your password if prompted.                                                                                      |
| <b>Step 2</b> | <b>configure terminal</b><br><b>Example:</b><br><br>Router# configure terminal<br>Router(config)#                                                                                                              | Enters global configuration mode.                                                                                                                   |
| <b>Step 3</b> | <b>interface cableslot / port</b><br><b>Example:</b><br><br>Router(config)# <b>interface cable 6/0</b><br>Router(config-if)#                                                                                   | Enters interface configuration mode for the cable interface line card at this particular slot.                                                      |
| <b>Step 4</b> | <b>cable upstream n concatenation</b><br><b>Example:</b><br><br>Router(config-if)# <b>cable upstream 0 concatenation</b><br>Router(config-if)# <b>cable upstream 1 concatenation</b><br><br>Router(config-if)# | Enables concatenation for the specified upstream on the cable interface.<br><br><b>Note</b> Repeat this command for each upstream on the interface. |

|        | Command or Action                                                                    | Purpose                             |
|--------|--------------------------------------------------------------------------------------|-------------------------------------|
| Step 5 | <b>exit</b><br><b>Example:</b><br><pre>Router(config-if)# exit Router(config)#</pre> | Exits interface configuration mode. |
| Step 6 | <b>exit</b><br><b>Example:</b><br><pre>Router(config)# exit Router#</pre>            | Exits global configuration mode.    |

## Enabling DOCSIS Fragmentation

To enable DOCSIS fragmentation for one or more upstreams on a cable interface (which is the default configuration), use the following procedure:

### SUMMARY STEPS

1. **enable**
2. **configure terminal**
3. **interface cableslot /port**
4. **cable upstreamn fragmentation**
5. **cable upstream n unfrag-slot-jitter [limitjitter | cac-enforce]**
6. **exit**
7. **exit**

### DETAILED STEPS

|        | Command or Action                                                                                      | Purpose                                                                                        |
|--------|--------------------------------------------------------------------------------------------------------|------------------------------------------------------------------------------------------------|
| Step 1 | <b>enable</b><br><b>Example:</b><br><pre>Router&gt; enable</pre> <b>Example:</b><br><pre>Router#</pre> | Enables privileged EXEC mode. Enter your password if prompted.                                 |
| Step 2 | <b>configure terminal</b><br><b>Example:</b><br><pre>Router# configure terminal Router(config)#</pre>  | Enters global configuration mode.                                                              |
| Step 3 | <b>interface cableslot /port</b><br><b>Example:</b>                                                    | Enters interface configuration mode for the cable interface line card at this particular slot. |

|               | Command or Action                                                                                                                                                                                                                | Purpose                                                                                                                                                                                                                                                                                                                                                                                                                                                                                                 |
|---------------|----------------------------------------------------------------------------------------------------------------------------------------------------------------------------------------------------------------------------------|---------------------------------------------------------------------------------------------------------------------------------------------------------------------------------------------------------------------------------------------------------------------------------------------------------------------------------------------------------------------------------------------------------------------------------------------------------------------------------------------------------|
|               | Router(config)# <b>interface cable 6/0</b><br>Router(config-if)#                                                                                                                                                                 |                                                                                                                                                                                                                                                                                                                                                                                                                                                                                                         |
| <b>Step 4</b> | <b>cable upstream <i>n</i> fragmentation</b><br><b>Example:</b><br><br>Router(config-if)# <b>cable upstream 2 fragmentation</b><br><br>Router(config-if)# <b>cable upstream 3 fragmentation</b><br>Router(config-if)#            | Enables fragmentation for the specified upstream on the cable interface.<br><br><b>Note</b> Repeat this command for each upstream on the interface.                                                                                                                                                                                                                                                                                                                                                     |
| <b>Step 5</b> | <b>cable upstream <i>n</i> unfrag-slot-jitter [<i>limit</i><i>jitter</i>   cac-enforce]</b><br><b>Example:</b><br><br>Router(config-if)# <b>cable upstream 0 unfrag-slot-jitter limit 2000 cac-enforce</b><br>Router(config-if)# | (Optional) Specifies the amount of jitter that can be tolerated on the upstream due to unfragmentable slots. The <b>limit</b> option specifies the allowable <i>jitter</i> limit in microseconds (0 to 4,294,967,295). The <b>cac-enforce</b> option configures the upstream so that it rejects service flows requesting jitter less than the fragmentable slot jitter.<br><br><b>Note</b> By default, <i>jitter</i> is set to a limit of 0 microseconds, and the <b>cac-enforce</b> option is enabled. |
| <b>Step 6</b> | <b>exit</b><br><b>Example:</b><br><br>Router(config-if)# <b>exit</b><br>Router(config)#                                                                                                                                          | Exits interface configuration mode.                                                                                                                                                                                                                                                                                                                                                                                                                                                                     |
| <b>Step 7</b> | <b>exit</b><br><b>Example:</b><br><br>Router(config)# <b>exit</b><br>Router#                                                                                                                                                     | Exits global configuration mode.                                                                                                                                                                                                                                                                                                                                                                                                                                                                        |

### Example

The following example of the **show cable qos profile** command illustrates that the maximum downstream burst has been defined, and is a management-created QoS profile:

```
Router# show cable qos profile
ID  Prio  Max  Guarantee Max  Max  TOS  TOS  Create  B  IP  prec.
      upstream  upstream  downstream  tx  mask  value  by  priv  rate
      bandwidth  bandwidth  bandwidth  burst
1    0    0    0          0          0    0xFF 0x0  cmts(r) no  no
2    0    64000 0          1000000    0    0xFF 0x0  cmts(r) no  no
3    7    31200 31200      0          0    0xFF 0x0  cmts  yes  no
4    7    87200 87200      0          0    0xFF 0x0  cmts  yes  no
6    1    90000 0          90000      1522 0xFF 0x0  mgmt  yes  no
10   1    90000 0          90000      1522 0x1  0xA0  mgmt  no   no
50   0    0      0          96000      0    0xFF 0x0  mgmt  no   no
51   0    0      0          97000      0    0xFF 0x0  mgmt  no   no
```

The following example illustrates the maximum downstream burst size in sample QoS profile 10 with the **show cable qos profile verbose** command in privileged EXEC mode:

```
Router# show cable qos profile 10 verbose
Profile Index          10
Name
Upstream Traffic Priority      1
Upstream Maximum Rate (bps)   90000
Upstream Guaranteed Rate (bps) 0
Unsolicited Grant Size (bytes) 0
Unsolicited Grant Interval (usecs) 0
Upstream Maximum Transmit Burst (bytes) 1522
Downstream Maximum Transmit Burst (bytes) 100000
IP Type of Service Overwrite Mask 0x1
IP Type of Service Overwrite Value 0xA0
Downstream Maximum Rate (bps) 90000
Created By                mgmt
Baseline Privacy Enabled   no
```

## Enabling DOCSIS 1.1 Downstream Maximum Transmit Burst on the Cisco cBR-8 Router

Perform the following steps to configure ERBA on the Cisco cBR-8 router. This procedure and the associated commands are subject to the guidelines and restrictions cited in this document.

### Procedure

|        | Command or Action                                                                                                                                     | Purpose                                                                                                                        |
|--------|-------------------------------------------------------------------------------------------------------------------------------------------------------|--------------------------------------------------------------------------------------------------------------------------------|
| Step 1 | <b>enable</b><br><b>Example:</b><br>Router> <b>enable</b>                                                                                             | Enables privileged EXEC mode. <ul style="list-style-type: none"> <li>• Enter your password if prompted.</li> </ul>             |
| Step 2 | <b>configure terminal</b><br><b>Example:</b><br>Router# <b>configure terminal</b><br>Router(config)#                                                  | Enters global configuration mode.                                                                                              |
| Step 3 | <b>[no] cable ds-max-burst burst-threshold <i>threshold</i></b><br><b>Example:</b><br>Router(config)# <b>cable ds-max-burst burst-threshold 2048</b>  | Enables the support for DOCSIS 1.1 downstream max burst. To remove this configuration, use the <b>no</b> form of this command. |
| Step 4 | <b>cable service class <i>class-index</i> peak-rate <i>peak-rate</i></b><br><b>Example:</b><br>Router(config)# <b>cable service class 1 peak-rate</b> | Set the peak-rate value of a specific service class.                                                                           |

|               | Command or Action                                                             | Purpose                          |
|---------------|-------------------------------------------------------------------------------|----------------------------------|
|               | 1000                                                                          |                                  |
| <b>Step 5</b> | <b>Ctrl^Z</b><br><b>Example:</b><br><pre>Router(config)# Ctrl^Z Router#</pre> | Returns to privileged EXEC mode. |

### Example

When this feature is enabled, new service flows with burst size larger than the burst threshold are supported. However, the existing service flows are not affected.

When this feature is disabled, no new service flows are configured with the *Downstream Maximum Transmit Burst* parameter—the **cable ds-max-burst** command settings. However, the existing service flows are not affected.

## Monitoring DOCSIS Operations

The following sections describe the commands that provide information about the DOCSIS network and its cable modems, the RF network and cable interfaces on the CMTS, and BPI+ operations.

### Monitoring the DOCSIS Network

The **show cable modem** command is the primary command to display the current state of cable modems and the DOCSIS network. This command has many options that provide information on different aspects of DOCSIS operations.

#### Displaying the Status of Cable Modems

To display a list of known cable modems and their current status, use the **show cable modem** command.

You can also display a particular cable modem by specifying its MAC address or IP address with the **show cable modem** command. If you specify the MAC address or IP address for a CPE device, the command will display the information for the cable modem that is associated with that device.



**Note** If the CPE IP address is no longer associated with a cable modem, the **show cable modem** command might not display information about the cable modem. To display the IP address of the CPE device for the cable modem, use the **clear cable host ip-address** command to clear the IP address of the modem from the router database, and then enter the **ping docsis mac-address** command, which resolves the MAC address by sending the DOCSIS ping to the CM.

To display a list of cable modems sorted by their manufacturer, use the **vendor** option.

The MAC state field in each of these displays shows the current state of the cable modem:



Table 289: Descriptions for the MAC State Field

| MAC State Value                                        | Description                                                                                                                                                                                                                                                                                                                                                                                                                                                                                                       |
|--------------------------------------------------------|-------------------------------------------------------------------------------------------------------------------------------------------------------------------------------------------------------------------------------------------------------------------------------------------------------------------------------------------------------------------------------------------------------------------------------------------------------------------------------------------------------------------|
| <b>Registration and Provisioning Status Conditions</b> |                                                                                                                                                                                                                                                                                                                                                                                                                                                                                                                   |
| init(r1)                                               | The CM sent initial ranging.                                                                                                                                                                                                                                                                                                                                                                                                                                                                                      |
| init(r2)                                               | The CM is ranging. The CMTS received initial ranging from the Cm and has sent RF power, timing offset, and frequency adjustments to the CM.                                                                                                                                                                                                                                                                                                                                                                       |
| init(rc)                                               | Ranging has completed.                                                                                                                                                                                                                                                                                                                                                                                                                                                                                            |
| init(d)                                                | The DHCP request was received. This also indicates that the first IP broadcast packet has been received from the CM.                                                                                                                                                                                                                                                                                                                                                                                              |
| init(i)                                                | The DHCP reply was received and the IP address has been assigned, but the CM has not yet replied with an IP packet.                                                                                                                                                                                                                                                                                                                                                                                               |
| init(o)                                                | The CM has begun to download the option file (DOCSIS configuration file) using the Trivial File Transfer Protocol (TFTP), as specified in the DHCP response. If the CM remains in this state, it indicates that the download has failed.                                                                                                                                                                                                                                                                          |
| init(t)                                                | Time-of-day (TOD) exchange has started.                                                                                                                                                                                                                                                                                                                                                                                                                                                                           |
| resetting                                              | The CM is being reset and will shortly restart the registration process.                                                                                                                                                                                                                                                                                                                                                                                                                                          |
| <b>Non-error Status Conditions</b>                     |                                                                                                                                                                                                                                                                                                                                                                                                                                                                                                                   |
| offline                                                | The CM is considered offline (disconnected or powered down).                                                                                                                                                                                                                                                                                                                                                                                                                                                      |
| online                                                 | The CM has registered and is enabled to pass data on the network.                                                                                                                                                                                                                                                                                                                                                                                                                                                 |
| online(d)                                              | The CM registered, but network access for the CM has been disabled through the DOCSIS configuration file.                                                                                                                                                                                                                                                                                                                                                                                                         |
| online(pk)                                             | The CM registered, BPI is enabled and KEK is assigned.                                                                                                                                                                                                                                                                                                                                                                                                                                                            |
| online(pt)                                             | The CM registered, BPI is enabled and TEK is assigned. BPI encryption is now being performed.                                                                                                                                                                                                                                                                                                                                                                                                                     |
| expire(pk)                                             | The Cm registered, BPI is enabled, KEK was assigned but has since expired.                                                                                                                                                                                                                                                                                                                                                                                                                                        |
| expire(pt)                                             | The Cm registered, BPI is enabled, TEK was assigned but has since expired.                                                                                                                                                                                                                                                                                                                                                                                                                                        |
| <b>Error Status Conditions</b>                         |                                                                                                                                                                                                                                                                                                                                                                                                                                                                                                                   |
| reject(m)                                              | <p>The CM attempted to register but registration was refused due to a bad Message Integrity Check (MIC) value. This also could indicate that the shared secret in the DOCSIS configuration file does not match the value configured on the CMTS with the <b>cable shared-secret</b> command.</p> <p>It can also indicate that the <b>cable tftp-enforce</b> command has been used to require that a CM attempt a TFTP download of the DOCSIS configuration file before registering, but the CM did not do so.</p> |

| MAC State Value | Description                                                                                                                                                                                                                                                                                                                                                                                                                                                                                                                                                                                         |
|-----------------|-----------------------------------------------------------------------------------------------------------------------------------------------------------------------------------------------------------------------------------------------------------------------------------------------------------------------------------------------------------------------------------------------------------------------------------------------------------------------------------------------------------------------------------------------------------------------------------------------------|
| reject(c)       | The CM attempted to register, but registration was refused due to a number of possible errors: <ul style="list-style-type: none"> <li>• The CM attempted to register with a minimum guaranteed upstream bandwidth that would exceed the limits imposed by the <b>cable upstream admission-control</b> command.</li> <li>• The CM has been disabled because of a security violation.</li> <li>• A bad class of service (COS) value in the DOCSIS configuration file.</li> <li>• The CM attempted to create a new COS configuration but the CMTS is configured to not permit such changes.</li> </ul> |
| reject(pk)      | KEK key assignment is rejected, BPI encryption has not been established.                                                                                                                                                                                                                                                                                                                                                                                                                                                                                                                            |
| reject(pt)      | TEK key assignment is rejected, BPI encryption has not been established.                                                                                                                                                                                                                                                                                                                                                                                                                                                                                                                            |
| reject(ts)      | The CM attempted to register, but registration failed because the TFTP server timestamp in the CM registration request did not match the timestamp maintained by the CMTS. This might indicate that the CM attempted to register by replaying an old DOCSIS configuration file used during a prior registration attempt.                                                                                                                                                                                                                                                                            |
| reject(ip)      | The CM attempted to register, but registration failed because the IP address in the CM request did not match the IP address that the TFTP server recorded when it sent the DOCSIS configuration file to the CM. IP spoofing could be occurring.                                                                                                                                                                                                                                                                                                                                                     |
| reject(na)      | The CM attempted to register, but registration failed because the CM did not send a Registration-Acknowledgement (REG-ACK) message in reply to the Registration-Response (REG-RSP) message sent by the CMTS. A Registration-NonAcknowledgement (REG-NACK) is assumed.                                                                                                                                                                                                                                                                                                                               |

## Displaying a Summary Report for the Cable Modems

The **show cable modem** command also can provide a summary report of the cable modems by using the **summary** and **total** options.

You can also use the **summary** and **total** options to display information for a single interface or a range of interfaces.

## Displaying the Capabilities of the Cable Modems

To display the capabilities and current DOCSIS provisioning for cable modems, use the **mac** option.

To get a summary report of the cable modems and their capabilities, use the **mac** option with the **summary** and **total** options.

## Displaying Detailed Information About a Particular Cable Modem

Several options for the **show cable modem** command display detailed information about a particular cable modem (as identified by its MAC address). The **verbose** option displays the most comprehensive output.

The **connectivity** and **maintenance** options also provide information that can be useful in troubleshooting problems with a particular cable modem.

## Monitoring the RF Network and Cable Interfaces

You can use the **show interface cable** command to display information about the operation of the RF network and the cable interfaces on the CMTS.



**Tip** For a complete description of the **show cable interface** command and its options, see the “Cisco Cable Modem Termination System Commands” chapter in the *Cisco Broadband Cable Command Reference Guide* (see [http://www.cisco.com/c/en/us/td/docs/cable/cbr/configuration/guide/b\\_cmts\\_quality\\_of\\_services/docsis\\_1\\_1.html#ref\\_1239231](http://www.cisco.com/c/en/us/td/docs/cable/cbr/configuration/guide/b_cmts_quality_of_services/docsis_1_1.html#ref_1239231)).

### Displaying Information About Cloned Cable Modems

To display the list of cable modems detected as cloned, use the **privacy hotlist** option with the **show interface cable** command.

### Denying RF Access For Cable Modems

To deny radio frequency (RF) access for cable modems during ranging, use the **cable privacy hotlist cm mac-address** command.

The following example shows how to block cloned cable modems using their own MAC address:

```
Router(config)# cable privacy hotlist cm 00C0.0102.0304
Router(config)#
```

When an operator identifies a modem’s MAC address that should not be registered on a specific CMTS, the operator can add this MAC address to the CMTS using the above command. This command ensures that the modem will not be allowed to come online on any interface on that CMTS.

### Displaying Information About the Mac Scheduler

To display information about the DOCSIS MAC layer scheduler that is operating on each cable interface, use the **mac-scheduler** option with the **show cable interface** command. You can display information for all of the upstreams on an interface, or you can display information for a single upstream on an interface.

### Displaying Information About QoS Parameter Sets

To display information about the DOCSIS 1.1 QoS parameter sets that have been defined on a cable interface, use the **qos paramset** option with the **show cable interface** command.

You can also display detailed information for a particular parameter set by specifying the index number for its Class of Service along with the **verbose** option.

### Displaying Information About Service Flows

To display the service flows and their QoS parameter sets that are configured on a cable interface, use the **service-flow** option with the **show interface cable** command.

To display the major QoS parameters for each service flow, add the **qos** option to this command.

To display the complete QoS parameters for a particular service flow, use the **qos** and **verbose** options. You can use these options separately or together.

## Displaying Information About Service IDs

To display information about Service IDs (SIDs), which are assigned to only upstreams in DOCSIS 1.1 networks, use the **sid** option with the **show interface cable** command.

Add the **qos** option to display the major QoS parameters associated with each SID.

To display detailed information about a particular SID and its QoS parameters, use both the **qos** and **verbose** options.

## Monitoring BPI+ Operations

See the following sections to monitor the state of BPI operations on the CMTS and its connected cable modems:

### Displaying the Current BPI+ State of Cable Modems

To display the current BPI+ state of cable modems, use the **show cable modem** command. If used without any options, this command displays the status for cable modems on all interfaces. You can also specify a particular cable interface on the CMTS, or the IP address or MAC address for a specific cable modem:

```
Router# show cable modem
      [ip-address
      | interface
      | mac-address
```

The MAC State column in the output of the **show cable modem** command displays the current status of each cable modem. The following are the possible BPI-related values for this field:

**Table 290: Possible show cable modem BPI+ States**

| State      | Description                                                                                                                                                                                                                                                                                                                                             |
|------------|---------------------------------------------------------------------------------------------------------------------------------------------------------------------------------------------------------------------------------------------------------------------------------------------------------------------------------------------------------|
| online     | A cable modem has come online and, if configured to use BPI+, is negotiating its privacy parameters for the session. If the modem remains in this state for more than a couple of minutes, it is online but not using BPI+. Check that the cable modem is running DOCSIS-certified software and is using a DOCSIS configuration file that enables BPI+. |
| online(pk) | The cable modem is online and has negotiated a Key Encryption Key(KEK) with the CMTS. If BPI+ negotiation is successful, this state will be shortly followed by online(pt).                                                                                                                                                                             |
| online(pt) | The cable modem is online and has negotiated a Traffic Encryption Key (TEK) with the CMTS. The BPI+ session has been established, and the cable modem is encrypting all user traffic with the CMTS using the specified privacy parameters.                                                                                                              |

| State      | Description                                                                                                                                                                                                                                                                                                                                                                                                                                                                                                                                                                                                                                                                                                                                                                                                                                       |
|------------|---------------------------------------------------------------------------------------------------------------------------------------------------------------------------------------------------------------------------------------------------------------------------------------------------------------------------------------------------------------------------------------------------------------------------------------------------------------------------------------------------------------------------------------------------------------------------------------------------------------------------------------------------------------------------------------------------------------------------------------------------------------------------------------------------------------------------------------------------|
| reject(pk) | <p>The cable modem failed to negotiate a KEK with the CMTS, typically because the cable modem failed authentication. Check that the cable modem is properly configured for BPI+ and is using valid digital certificates. If the CMTS requires BPI+ for registration, the cable modem will go offline and have to reregister. Check that the cable modem is properly registered in the CMTS provisioning system.</p> <p><b>Note</b> If a cable modem fails BPI+ authentication, a message similar to the following appears in the CMTS log:</p> <pre>%CBR-5-UNAUTHSIDTIMEOUT: CMTS deleted BPI unauthorized Cable Modem 00c0.abcd.ef01</pre> <p><b>Note</b> In cBR-8, if the CM status has a * (asterisk) as prefix, the router does not apply ACL to block the Layer 3 traffic of the CM. While in Cisco uBR10000, the router will apply ACL.</p> |
| reject(pt) | <p>The cable modem failed to successfully negotiate a TEK with the CMTS. If the CMTS requires BPI+ for registration, the cable modem will have to reregister.</p>                                                                                                                                                                                                                                                                                                                                                                                                                                                                                                                                                                                                                                                                                 |

## Displaying the BPI+ Timer Values on the CMTS

To display the values for the KEK and TEK lifetime timers on a particular cable interface, use the **show interface cable x/y privacy [kek | tek]** command.

## Displaying the Certificate List on the CMTS

Use the **show crypto ca certificates** command to display the list of known certificates on the CMTS. For example:

```
Router# show crypto ca certificates

Certificate
  Status: Available
  Certificate Serial Number: 7DBF85DDDD8358546BB1C67A16B3D832
  Key Usage: General Purpose
  Subject Name
    Name: Cisco Systems
  Validity Date:
    start date: 00:00:00 UTC Sep 12 2001
    end   date: 23:59:59 UTC Sep 11 2021
Root certificate
  Status: Available
  Certificate Serial Number: 5853648728A44DC0335F0CDB33849C19
  Key Usage: General Purpose
    CN = DOCSIS Cable Modem Root Certificate Authority
    OU = Cable Modems
    O = Data Over Cable Service Interface Specifications
    C = US
  Validity Date:
    start date: 00:00:00 UTC Feb 1 2001
    end   date: 23:59:59 UTC Jan 31 2031
```

# Configuration Examples for DOCSIS 1.1 Operations

This section lists the following sample configurations for DOCSIS 1.1 operations on the Cisco CMTS:

## Example: DOCSIS 1.1 Configuration for Cisco cBR-8 Router (with BPI+)

```

version 12.2
service timestamps log datetime msec localtime
service password-encryption
!
hostname cBR-8
!
redundancy
 main-cpu
  auto-sync standard
logging queue-limit 100
no logging buffered
no logging rate-limit
enable password my-enable-password
!
ipc cache 5000
card 1/1 2cable-tccplus
card 2/0 1gigetherenet-1
card 2/1 2cable-tccplus
card 3/0 1gigetherenet-1
card 4/0 1oc12pos-1
card 8/0 5cable-mc520s
card 8/1 5cable-mc520s
cable flap-list insertion-time 60
cable flap-list power-adjust threshold 4
cable flap-list aging 86400
cable modem vendor 00.50.F1 TI
cable spectrum-group 2 band 11000000 16000000
cable spectrum-group 21 band 17000000 25000000
cable spectrum-group 32 shared
cable spectrum-group 32 band 5000000 42000000
cable modulation-profile 2 request 0 16 0 8 qpsk scrambler 152 no-diff 64 fixed uw16
cable modulation-profile 2 initial 5 34 0 48 qpsk scrambler 152 no-diff 128 fixed uw16
cable modulation-profile 2 station 5 34 0 48 qpsk scrambler 152 no-diff 128 fixed uw16
cable modulation-profile 2 short 6 75 6 8 16qam scrambler 152 no-diff 144 shortened uw8
cable modulation-profile 2 long 8 220 0 8 16qam scrambler 152 no-diff 160 shortened uw8
cable modulation-profile 21 request 0 16 0 22 qpsk scrambler 152 no-diff 32 fixed
cable modulation-profile 21 initial 5 34 0 48 qpsk scrambler 152 no-diff 64 fixed
cable modulation-profile 21 station 5 34 0 48 qpsk scrambler 152 no-diff 64 fixed
cable modulation-profile 21 short 3 76 12 22 qpsk scrambler 152 no-diff 64 shortened
cable modulation-profile 21 long 7 231 0 22 qpsk scrambler 152 no-diff 64 shortened
cable modulation-profile 22 request 0 16 0 22 qpsk scrambler 152 no-diff 32 fixed
cable modulation-profile 22 initial 5 34 0 48 qpsk scrambler 152 no-diff 64 fixed
cable modulation-profile 22 station 5 34 0 48 qpsk scrambler 152 no-diff 64 fixed
cable modulation-profile 22 short 4 76 7 22 16qam scrambler 152 no-diff 128 shortened
cable modulation-profile 22 long 7 231 0 22 16qam scrambler 152 no-diff 128 shortened
cable modulation-profile 23 request 0 16 0 22 qpsk scrambler 152 no-diff 32 fixed
cable modulation-profile 23 initial 5 34 0 48 qpsk scrambler 152 no-diff 64 fixed
cable modulation-profile 23 station 5 34 0 48 qpsk scrambler 152 no-diff 64 fixed
cable modulation-profile 23 short 4 76 7 22 16qam scrambler 152 no-diff 128 shortened
cable modulation-profile 23 long 7 231 0 22 16qam scrambler 152 no-diff 128 shortened
cable qos profile 5 max-downstream 10000
cable qos profile 5 max-upstream 1000
cable qos profile 5 priority 7

```

```
cable qos profile 5 tos-overwrite 0x3 0x0
cable qos profile 5 name cm_no_priority
cable qos profile 6 max-downstream 10000
cable qos profile 6 max-upstream 5000
cable qos profile 6 priority 7
cable qos profile 6 tos-overwrite 0x3 0x0
cable qos profile 6 name qos6
cable qos profile 7 max-downstream 128
cable qos profile 7 max-upstream 128
cable qos profile 7 priority 7
cable qos profile 8 max-downstream 10000
cable qos profile 8 max-upstream 1000
cable qos profile 8 priority 3
cable qos profile 8 tos-overwrite 0x3 0x0
cable qos profile 8 name qos8
no cable qos permission create
no cable qos permission update
cable qos permission modems
cable event syslog-server 10.10.10.131
ip subnet-zero
!
!
interface FastEthernet0/0/0
 ip address 10.10.32.21 255.255.0.0
 no cdp enable
!
interface GigabitEthernet2/0/0
 ip address 10.10.31.2 255.0.0.0
 no ip redirects
 no ip unreachable
 no ip proxy-arp
 load-interval 30
 negotiation auto
 no cdp enable
!
interface GigabitEthernet3/0/0
 no ip address
 ip pim sparse-mode
 no ip route-cache cef
 load-interval 30
 shutdown
 negotiation auto
 no cdp enable
!
interface POS4/0/0
 no ip address
 crc 32
 no cdp enable
 pos ais-shut
!
!
interface Cable8/0/0
 ip address 10.10.10.28 255.255.255.0
 ip helper-address 1.10.10.133
 cable bundle 2 master
 cable downstream annex B
 cable downstream modulation 64qam
 cable downstream interleave-depth 32
 cable downstream frequency 669000000
 cable downstream channel-id 0
 no cable downstream rf-shutdown
 cable downstream rf-power 45
 cable upstream 0 connector 0
 cable upstream 0 spectrum-group 32
```

## Example: DOCSIS 1.1 Configuration for Cisco cBR-8 Router (with BPI+)

```

cable upstream 0 power-level 0
cable upstream 0 channel-width 1600000
cable upstream 0 minislot-size 4
cable upstream 0 range-backoff 3 6
cable upstream 0 data-backoff 0 6
cable upstream 0 modulation-profile 23
no cable upstream 0 rate-limit
no cable upstream 0 shutdown
cable upstream 1 connector 1
cable upstream 1 spectrum-group 32
cable upstream 1 power-level 0
cable upstream 1 channel-width 1600000
cable upstream 1 minislot-size 4
cable upstream 1 data-backoff 0 6
cable upstream 1 modulation-profile 23
no cable upstream 1 shutdown
cable upstream 2 connector 2
cable upstream 2 spectrum-group 32
cable upstream 2 power-level 0
cable upstream 2 channel-width 1600000
cable upstream 2 minislot-size 4
cable upstream 2 data-backoff 3 6
cable upstream 2 modulation-profile 23
no cable upstream 2 shutdown
cable upstream 3 connector 3
cable upstream 3 spectrum-group 32
cable upstream 3 channel-width 1600000
cable upstream 3 minislot-size 4
cable upstream 3 modulation-profile 21
no cable upstream 3 shutdown
cable source-verify
cable privacy kek life-time 300
cable privacy tek life-time 180
no keepalive
!
interface Cable8/0/1
ip address 10.10.11.121
cable bundle 2
cable downstream annex B
cable downstream modulation 64qam
cable downstream interleave-depth 32
cable downstream frequency 453000000
cable downstream channel-id 0
no cable downstream rf-shutdown
cable upstream max-ports 6
cable upstream 0 connector 4
cable upstream 0 spectrum-group 2
cable upstream 0 power-level 0
cable upstream 0 channel-width 1600000
cable upstream 0 minislot-size 4
cable upstream 0 range-backoff 3 6
cable upstream 0 data-backoff 0 6
cable upstream 0 modulation-profile 23 21
no cable upstream 0 rate-limit
cable upstream 0 shutdown
cable upstream 1 connector 5
cable upstream 1 channel-width 1600000
cable upstream 1 minislot-size 4
cable upstream 1 modulation-profile 21
cable upstream 1 shutdown
cable upstream 2 connector 6
cable upstream 2 channel-width 1600000
cable upstream 2 minislot-size 4
cable upstream 2 modulation-profile 21

```



```

cable upstream 2 shutdown
cable upstream 3 connector 7
cable upstream 3 channel-width 1600000
cable upstream 3 minislots-size 4
cable upstream 3 modulation-profile 21
cable upstream 3 shutdown
cable upstream 4 channel-width 1600000
cable upstream 4 minislots-size 4
cable upstream 4 modulation-profile 21
cable upstream 4 shutdown
cable upstream 5 channel-width 1600000
cable upstream 5 minislots-size 4
cable upstream 5 modulation-profile 21
cable upstream 5 shutdown
cable source-verify
cable privacy kek life-time 300
cable privacy tek life-time 180
no keepalive
!
!
ip classless
ip http server
no ip http secure-server
!
!
no cdp run
snmp-server community public RW
snmp-server community private RW
snmp-server enable traps cable
!
line con 0
  exec-timeout 0 0
line aux 0
line vty 0 4
  exec-timeout 0 0
  password my-telnet-password
  login
  length 0
!
end

```

## Additional References

For additional information related to DOCSIS 1.1 operations, refer to the following references:

### Technical Assistance

| Description                                                                                                                                                                                                                                                                                                                                                                           | Link                                                                                                              |
|---------------------------------------------------------------------------------------------------------------------------------------------------------------------------------------------------------------------------------------------------------------------------------------------------------------------------------------------------------------------------------------|-------------------------------------------------------------------------------------------------------------------|
| The Cisco Support and Documentation website provides online resources to download documentation, software, and tools. Use these resources to install and configure the software and to troubleshoot and resolve technical issues with Cisco products and technologies. Access to most tools on the Cisco Support and Documentation website requires a Cisco.com user ID and password. | <a href="http://www.cisco.com/cisco/web/support/index.html">http://www.cisco.com/cisco/web/support/index.html</a> |

## Feature Information for DOCSIS 1.1 for Cisco CMTS Routers

Use Cisco Feature Navigator to find information about the platform support and software image support. Cisco Feature Navigator enables you to determine which software images support a specific software release, feature set, or platform. To access Cisco Feature Navigator, go to the <https://cfng.cisco.com/> link. An account on the Cisco.com page is not required.



**Note** The following table lists the software release in which a given feature is introduced. Unless noted otherwise, subsequent releases of that software release train also support that feature.

*Table 291: Feature Information for DOCSIS 1.1 for the Cisco CMTS Routers*

| Feature Name                          | Releases                    | Feature Information                                                                                           |
|---------------------------------------|-----------------------------|---------------------------------------------------------------------------------------------------------------|
| DOCSIS 1.1 for the Cisco CMTS Routers | Cisco IOS XE Everest 16.6.1 | This feature was integrated into Cisco IOS XE Everest 16.6.1 on Cisco cBR Series Converged Broadband Routers. |



## CHAPTER 91

# Default DOCSIS 1.0 ToS Overwrite

---

This document describes the Default DOCSIS 1.0 ToS Overwrite feature for the Cisco Cable Modem Termination System (CMTS). This feature eliminates the need to create multiple QoS profiles in order to perform type of service (ToS) overwrite by enabling a default ToS overwrite to be bound to all DOCSIS 1.0 Cable Modem (CM) created profiles.

Your software release may not support all the features that are documented in this module. For the latest feature information and caveats, see the release notes for your platform and software release. The Feature Information Table at the end of this document provides information about the documented features and lists the releases in which each feature is supported.

Use Cisco Feature Navigator to find information about platform support and Cisco software image support. To access Cisco Feature Navigator, go to <http://tools.cisco.com/ITDIT/CFN/>. An account on <http://www.cisco.com/> is not required.

### Contents

- [Hardware Compatibility Matrix for the Cisco cBR Series Routers, on page 1463](#)
- [Restrictions for Default DOCSIS 1.0 ToS Overwrite, on page 1464](#)
- [Information About Default DOCSIS 1.0 ToS Overwrite, on page 1465](#)
- [How to Configure Default DOCSIS 1.0 ToS Overwrite, on page 1466](#)
- [Additional References, on page 1467](#)
- [Feature Information for Default DOCSIS 1.0 ToS Overwrite, on page 1468](#)

## Hardware Compatibility Matrix for the Cisco cBR Series Routers



---

**Note** The hardware components that are introduced in a given Cisco IOS-XE Release are supported in all subsequent releases unless otherwise specified.

---

Table 292: Hardware Compatibility Matrix for the Cisco cBR Series Routers

| Cisco CMTS Platform                    | Processor Engine                                                                                                                                                                                  | Interface Cards                                                                                                                                                                                                                                                                                                                                                                                                                                                                                                                                                                                                                                                                                                                                                                                 |
|----------------------------------------|---------------------------------------------------------------------------------------------------------------------------------------------------------------------------------------------------|-------------------------------------------------------------------------------------------------------------------------------------------------------------------------------------------------------------------------------------------------------------------------------------------------------------------------------------------------------------------------------------------------------------------------------------------------------------------------------------------------------------------------------------------------------------------------------------------------------------------------------------------------------------------------------------------------------------------------------------------------------------------------------------------------|
| Cisco cBR-8 Converged Broadband Router | <p><b>Cisco IOS-XE Release 16.5.1 and Later Releases</b></p> <p>Cisco cBR-8 Supervisor:</p> <ul style="list-style-type: none"> <li>• PID—CBR-SUP-250G</li> <li>• PID—CBR-CCAP-SUP-160G</li> </ul> | <p><b>Cisco IOS-XE Release 16.5.1 and Later Releases</b></p> <p>Cisco cBR-8 CCAP Line Cards:</p> <ul style="list-style-type: none"> <li>• PID—CBR-LC-8D30-16U30</li> <li>• PID—CBR-LC-8D31-16U30</li> <li>• PID—CBR-RF-PIC</li> <li>• PID—CBR-RF-PROT-PIC</li> <li>• PID—CBR-CCAP-LC-40G</li> <li>• PID—CBR-CCAP-LC-40G-R</li> <li>• PID—CBR-CCAP-LC-G2-R</li> <li>• PID—CBR-SUP-8X10G-PIC</li> <li>• PID—CBR-2X100G-PIC</li> </ul> <p>Digital PICs:</p> <ul style="list-style-type: none"> <li>• PID—CBR-DPIC-8X10G</li> <li>• PID—CBR-DPIC-2X100G</li> </ul> <p>Cisco cBR-8 Downstream PHY Module:</p> <ul style="list-style-type: none"> <li>• PID—CBR-D31-DS-MOD</li> </ul> <p>Cisco cBR-8 Upstream PHY Modules:</p> <ul style="list-style-type: none"> <li>• PID—CBR-D31-US-MOD</li> </ul> |



**Note** Do not use DPICs (8X10G and 2x100G) to forward IP traffic, as it may cause buffer exhaustion, leading to line card reload.

The only allowed traffic on a DPIC interface is DEPI, UEPI, and GCP traffic from the Cisco cBR-8 router to Remote PHY devices. Other traffic such as DHCP, SSH, and UTSC should flow via another router, since DPICs cannot be used for normal routing.

## Restrictions for Default DOCSIS 1.0 ToS Overwrite

- The Default DOCSIS 1.0 ToS Overwrite feature is only applicable to CMs running DOCSIS version 1.0.

- Once the Default DOCSIS 1.0 ToS Overwrite feature is configured, all CMs will need to be reset in order for the effect to take place.
- Once the Default DOCSIS 1.0 ToS Overwrite feature is configured, all CMs will display the default values that were configured. After which, overwrite values can only be changed by editing the QoS profiles.

## Information About Default DOCSIS 1.0 ToS Overwrite

To configure the Default DOCSIS 1.0 ToS Overwrite feature, you should understand the following topic:

### Default DOCSIS 1.0 ToS Overwrite Overview

Currently, ToS overwrite requires the creation of static cable QoS profiles, which are assigned ToS fields and are then associated with 1.0 CMs. This implementation works well if only a few different service types are offered.

However, scalability issues arise when large numbers of service types are presented; each requiring a static QoS profile in order to perform ToS overwrite.

The Default DOCSIS 1.0 ToS Overwrite feature eliminates the need to create multiple QoS profiles in order to perform type-of-service (ToS) overwrite by automatically bounding all DOCSIS 1.0 Cable Modem (CM) created profiles to a default ToS overwrite.

## DOCSIS

Created by CableLabs, Data Over Cable Service Interface Specification (DOCSIS) defines the interface standards and requirements for all cable modems associated with high-speed data distribution over a cable television system network.

The DOCSIS architecture consists of the following two components:

- Cable Modem (CM)
- Cable Modem Termination System (CMTS)

Each of these components are situated at different locations, often with the CM located on a customer site and the CMTS on the service provider site, and communication between the CM and CMTS is conducted over cable through DOCSIS.



---

**Note** Though there are several versions of DOCSIS available, the Default DOCSIS 1.0 ToS Overwrite feature is only applicable to CMs running DOCSIS 1.0.

---

## Type-of-Service (ToS)

Tools such as type-of-service (ToS) bits identification make it possible to isolate network traffic by the type of application being used. ToS capabilities can be further expanded to isolate network traffic down to the specific brands, by the interface used, by the user type and individual user identification, or by the site address.

# How to Configure Default DOCSIS 1.0 ToS Overwrite

The tasks in this section enables the use of the Default DOCSIS 1.0 ToS Overwrite feature.

## Enabling Default DOCSIS 1.0 ToS Overwrite

All CMs with a DOCSIS 1.0 configuration file currently have their ToS overwrite default values are set to `tos-and: 0xff` and `tos-or: 0x00`. Since there were previously no mechanism in the DOCSIS 1.0 configuration file to specify the ToS overwrite, QoS profiles were created and assigned to the default ToS overwrites.

The following procedures enable the Default DOCSIS 1.0 ToS Overwrite feature, which will allow a default ToS overwrite to be bound to all CM created profiles.

### Before you begin

There are no prerequisites for these procedures.



#### Note

- The Default DOCSIS 1.0 ToS Overwrite feature is only applicable to CMs running DOCSIS version 1.0.
- Once the Default DOCSIS 1.0 ToS Overwrite feature is configured, all CMs will need to be reset in order for the effect to take place.
- Once the Default DOCSIS 1.0 ToS Overwrite feature is configured, all CMs will display the default values that were configured. After which, overwrite values can only be changed by editing the QoS profiles.

### Procedure

|        | Command or Action                                                                                                                                           | Purpose                                                                                                                    |
|--------|-------------------------------------------------------------------------------------------------------------------------------------------------------------|----------------------------------------------------------------------------------------------------------------------------|
| Step 1 | <b>enable</b><br><b>Example:</b><br>Router> enable                                                                                                          | Enables privileged EXEC mode. <ul style="list-style-type: none"> <li>• Enter your password if prompted.</li> </ul>         |
| Step 2 | <b>configureterminal</b><br><b>Example:</b><br>Router# configure terminal                                                                                   | Enters global configuration mode.                                                                                          |
| Step 3 | <b>cable default-tos-qos10 tos-overwrite <i>tos-and tos-or</i></b><br><b>Example:</b><br>Router(config)# cable default-tos-qos10<br>tos-overwrite 0x1F 0xE0 | Configures the ToS overwrite default value for the CM. This default value will be bound to all future CM created profiles. |
| Step 4 | <b>end</b><br><b>Example:</b>                                                                                                                               | Exits interface configuration mode and returns to privileged EXEC mode.                                                    |

|  | Command or Action             | Purpose |
|--|-------------------------------|---------|
|  | Router(config-if)# <b>end</b> |         |

### What to do next

After configuring the ToS overwrite default value, reset the CM using the **clear cable modem delete** command to allow the new ToS overwrite default value to take effect.

## Editing QoS Profiles

Once the Default DOCSIS 1.0 ToS Overwrite feature is configured, additional ToS overwrite values can be changed by editing the QoS profiles.

### Procedure

|               | Command or Action                                                                                                                                                                                                                                                                                                          | Purpose                                                                                                            |
|---------------|----------------------------------------------------------------------------------------------------------------------------------------------------------------------------------------------------------------------------------------------------------------------------------------------------------------------------|--------------------------------------------------------------------------------------------------------------------|
| <b>Step 1</b> | <b>enable</b><br><b>Example:</b><br>Router> enable                                                                                                                                                                                                                                                                         | Enables privileged EXEC mode. <ul style="list-style-type: none"> <li>• Enter your password if prompted.</li> </ul> |
| <b>Step 2</b> | <b>configureterminal</b><br><b>Example:</b><br>Router# configure terminal                                                                                                                                                                                                                                                  | Enters global configuration mode.                                                                                  |
| <b>Step 3</b> | <b>cable qos profile</b> { <i>groupnum</i>   <i>ip-precedence</i>   <i>guaranteed-upstream</i>   <i>max-burst</i>   <i>max-upstream</i>   <i>max-downstream</i>   <i>priority</i>   <i>tos-overwrite</i>   <i>value</i> }<br><b>Example:</b><br>Router(config)# <b>cable qos profile 4</b><br><b>guaranteed-upstream 2</b> | Configures the QoS profile.                                                                                        |
| <b>Step 4</b> | <b>end</b><br><b>Example:</b><br>Router(config-if)# <b>end</b>                                                                                                                                                                                                                                                             | Exits interface configuration mode and returns to privileged EXEC mode.                                            |

## Additional References

The following sections provide references related to the Default DOCSIS 1.0 ToS Overwrite feature.

**Technical Assistance**

| Description                                                                                                                                                                                                                                                                                                  | Link                                                                                                              |
|--------------------------------------------------------------------------------------------------------------------------------------------------------------------------------------------------------------------------------------------------------------------------------------------------------------|-------------------------------------------------------------------------------------------------------------------|
| The Cisco Technical Support & Documentation website contains thousands of pages of searchable technical content, including links to products, technologies, solutions, technical tips, tools, and technical documentation. Registered Cisco.com users can log in from this page to access even more content. | <a href="http://www.cisco.com/cisco/web/support/index.html">http://www.cisco.com/cisco/web/support/index.html</a> |

## Feature Information for Default DOCSIS 1.0 ToS Overwrite

Use Cisco Feature Navigator to find information about the platform support and software image support. Cisco Feature Navigator enables you to determine which software images support a specific software release, feature set, or platform. To access Cisco Feature Navigator, go to the <https://cfng.cisco.com/> link. An account on the Cisco.com page is not required.



**Note** The following table lists the software release in which a given feature is introduced. Unless noted otherwise, subsequent releases of that software release train also support that feature.

**Table 293: Feature Information for Default DOCSIS 1.0 ToS Overwrite**

| Feature Name                     | Releases                    | Feature Information                                                                                               |
|----------------------------------|-----------------------------|-------------------------------------------------------------------------------------------------------------------|
| Default DOCSIS 1.0 ToS overwrite | Cisco IOS XE Everest 16.6.1 | This feature was integrated into Cisco IOS XE Everest 16.6.1 on the Cisco cBR Series Converged Broadband Routers. |





## CHAPTER 92

# DOCSIS WFQ Scheduler on the Cisco CMTS Routers

---

The DOCSIS WFQ Scheduler is an output packet scheduler that provides output scheduling services on both WAN uplink interfaces and DOCSIS downstream interfaces.

Your software release may not support all the features that are documented in this module. For the latest feature information and caveats, see the release notes for your platform and software release. The Feature Information Table at the end of this document provides information about the documented features and lists the releases in which each feature is supported.

Use Cisco Feature Navigator to find information about platform support and Cisco software image support. To access Cisco Feature Navigator, go to <http://tools.cisco.com/ITDIT/CFN/>. An account on <http://www.cisco.com/> is not required.

### Contents

- [Hardware Compatibility Matrix for the Cisco cBR Series Routers, on page 1469](#)
- [Prerequisites for DOCSIS WFQ Scheduler, on page 1470](#)
- [Restrictions for DOCSIS WFQ Scheduler, on page 1471](#)
- [Information About DOCSIS WFQ Scheduler, on page 1471](#)
- [How to Configure DOCSIS WFQ Scheduler , on page 1477](#)
- [Additional References, on page 1478](#)
- [Feature Information for DOCSIS WFQ Scheduler, on page 1478](#)

## Hardware Compatibility Matrix for the Cisco cBR Series Routers



---

**Note** The hardware components that are introduced in a given Cisco IOS-XE Release are supported in all subsequent releases unless otherwise specified.

---

Table 294: Hardware Compatibility Matrix for the Cisco cBR Series Routers

| Cisco CMTS Platform                    | Processor Engine                                                                                                                                                                                  | Interface Cards                                                                                                                                                                                                                                                                                                                                                                                                                                                                                                                                                                                                                                                                                                                                                                                 |
|----------------------------------------|---------------------------------------------------------------------------------------------------------------------------------------------------------------------------------------------------|-------------------------------------------------------------------------------------------------------------------------------------------------------------------------------------------------------------------------------------------------------------------------------------------------------------------------------------------------------------------------------------------------------------------------------------------------------------------------------------------------------------------------------------------------------------------------------------------------------------------------------------------------------------------------------------------------------------------------------------------------------------------------------------------------|
| Cisco cBR-8 Converged Broadband Router | <p><b>Cisco IOS-XE Release 16.5.1 and Later Releases</b></p> <p>Cisco cBR-8 Supervisor:</p> <ul style="list-style-type: none"> <li>• PID—CBR-SUP-250G</li> <li>• PID—CBR-CCAP-SUP-160G</li> </ul> | <p><b>Cisco IOS-XE Release 16.5.1 and Later Releases</b></p> <p>Cisco cBR-8 CCAP Line Cards:</p> <ul style="list-style-type: none"> <li>• PID—CBR-LC-8D30-16U30</li> <li>• PID—CBR-LC-8D31-16U30</li> <li>• PID—CBR-RF-PIC</li> <li>• PID—CBR-RF-PROT-PIC</li> <li>• PID—CBR-CCAP-LC-40G</li> <li>• PID—CBR-CCAP-LC-40G-R</li> <li>• PID—CBR-CCAP-LC-G2-R</li> <li>• PID—CBR-SUP-8X10G-PIC</li> <li>• PID—CBR-2X100G-PIC</li> </ul> <p>Digital PICs:</p> <ul style="list-style-type: none"> <li>• PID—CBR-DPIC-8X10G</li> <li>• PID—CBR-DPIC-2X100G</li> </ul> <p>Cisco cBR-8 Downstream PHY Module:</p> <ul style="list-style-type: none"> <li>• PID—CBR-D31-DS-MOD</li> </ul> <p>Cisco cBR-8 Upstream PHY Modules:</p> <ul style="list-style-type: none"> <li>• PID—CBR-D31-US-MOD</li> </ul> |



**Note** Do not use DPICs (8X10G and 2x100G) to forward IP traffic, as it may cause buffer exhaustion, leading to line card reload.

The only allowed traffic on a DPIC interface is DEPI, UEPI, and GCP traffic from the Cisco cBR-8 router to Remote PHY devices. Other traffic such as DHCP, SSH, and UTSC should flow via another router, since DPICs cannot be used for normal routing.

## Prerequisites for DOCSIS WFQ Scheduler

No special equipment or software is needed to use the DOCSIS WFQ Scheduler feature.

## Restrictions for DOCSIS WFQ Scheduler

- The DBS feature is only applicable to DOCSIS 3.0 downstream channel bonding.

## Information About DOCSIS WFQ Scheduler

The DOCSIS WFQ scheduling engine is used to provide output packet scheduling services, including absolute priority queueing, weighted fair queueing, minimum rate guarantee, traffic shaping, and DOCSIS bonding group dynamic bandwidth sharing on the Cisco cBR-8 converged broadband router.

The DOCSIS WFQ Scheduler provides services on both WAN uplink interfaces and DOCSIS downstream interfaces. The scheduling parameters on WAN uplink interfaces are configured through the Modular QoS CLI (MQC). On cable downstream interfaces, queues are created for DOCSIS service flows with parameters configured by DOCSIS downstream QoS type, length, values (TLVs).

The default queue size for the DOCSIS service flows (with bandwidth greater than 150 Mbps) is based on the bandwidth on the cable downstream interfaces (see Table below). Additionally, the queue limit for all service flows can also be adjusted using the **cable queue-limit** command, buffer size in service class or downstream buffer control TLVs.



**Note** The default queue size change, and the **cable queue-limit** command do not affect the DOCSIS high priority queues.

Table below is an example of the queue size based on Annex B 256 QAM channels.

**Table 295: Bandwidth, Queue Sizes, and Queue Limits**

| Channel | Bandwidth (Mbps) | Default Queue Size | Queue Size |       |       |       |        |
|---------|------------------|--------------------|------------|-------|-------|-------|--------|
|         |                  |                    | 1 ms       | 20 ms | 30 ms | 40 ms | 200 ms |
| 1       | 37.5             | 63                 | 63         | 63    | 92    | 123   | 617    |
| 2       | 75               | 255                | 63         | 123   | 185   | 247   | 1235   |
| 3       | 112.5            | 255                | 63         | 185   | 277   | 370   | 1852   |
| 4       | 150              | 255                | 63         | 247   | 370   | 494   | 2470   |
| 5       | 187.5            | 319                | 63         | 308   | 463   | 617   | 3087   |
| 6       | 225              | 383                | 63         | 370   | 555   | 741   | 3705   |
| 7       | 262.5            | 447                | 63         | 432   | 648   | 864   | 4323   |
| 8       | 300              | 511                | 63         | 494   | 741   | 988   | 4940   |
| 12      | 450              | 767                | 63         | 741   | 1111  | 1482  | 7411   |

| Channel | Bandwidth (Mbps) | Default Queue Size | Queue Size |       |       |       |        |
|---------|------------------|--------------------|------------|-------|-------|-------|--------|
|         |                  |                    | 1 ms       | 20 ms | 30 ms | 40 ms | 200 ms |
| 14      | 525              | 895                | 63         | 864   | 1296  | 1729  | 8646   |
| 16      | 600              | 1023               | 63         | 988   | 1482  | 1976  | 9881   |

The DOCSIS WFQ Scheduler also allows significant enhancement to the queue scaling limits.

The following sections explain the DOCSIS WFQ Scheduler features:

## Queue Types

The DOCSIS WFQ Scheduler feature supports the following types of queues:

- Priority queues
- CIR queues
- Best Effort queues

### Priority Queues

Priority queues are serviced with absolute priority over all the other queues. On DOCSIS downstream interfaces, the priority queues are configured by DOCSIS applications that request a priority service flow, for example, a packet cable voice service flow. On WAN uplink interfaces, the priority queues are configured by the MQC policy maps.

The following restrictions apply to priority queues:

- Only one priority queue is allowed per WAN uplink interface.
- Only one priority queue is allowed for low latency service flows created for each DOCSIS downstream interface.
- All low latency flows on a DOCSIS downstream are aggregated to the single priority queue.

### CIR Queues

A CIR queue is guaranteed to be serviced with at least the Committed Information Rate (CIR). CIR queues are used to service DOCSIS service flows with non-zero minimum reserved rates. If the offered load to a CIR queue exceeds its CIR value, the excess traffic is serviced as best effort traffic.

### Best Effort Queues

The Best Effort (BE) queues share the interface bandwidth not used by the priority queue and the CIR queues. The sharing is in proportion to each queue's excess ratio.

The following conditions apply to BE queues:

- On DOCSIS downstream interfaces, BE queues are created by DOCSIS service flows that do not request a minimum reserved rate.
- Each DOCSIS flow without a minimum reserved rate uses its own BE queue.

## DOCSIS QoS Support

DOCSIS defines a set of quality of service (QoS) parameters, including traffic priority, maximum sustained traffic rate, minimum reserved traffic rate, maximum traffic burst, maximum downstream latency, and peak traffic rate.

The downstream service flows use the QoS parameters to specify the desired QoS. The downstream policer and scheduler provides services such as traffic shaping, bandwidth provisioning, traffic prioritization, and bandwidth guarantee.

The DOCSIS service flow parameters are mapped to the packet queue parameters and provided with appropriate QoS support for the packet queues to support the DOCSIS parameters

The following DOCSIS QoS parameters are supported:

- Traffic priority
- Maximum sustained traffic rate
- Minimum reserved traffic rate



**Note** The maximum traffic burst size and the peak traffic rate are supported as described in the [http://www.cisco.com/c/en/us/td/docs/cable/cbr/configuration/guide/b\\_cmts\\_quality\\_of\\_services/docsis\\_wfq\\_scheduler.html#con\\_1085732](http://www.cisco.com/c/en/us/td/docs/cable/cbr/configuration/guide/b_cmts_quality_of_services/docsis_wfq_scheduler.html#con_1085732).

## Traffic Priority

The downstream channel bandwidth available to the best effort traffic, namely the channel bandwidth minus the amount consumed by the priority traffic and the CIR traffic, is allocated to the best effort service flows in proportion to their DOCSIS traffic priorities. For example, if there are three service flows sending packets at a particular moment over the same downstream channel, and their DOCSIS traffic priorities are 0, 1 and 3, respectively, their share of the channel bandwidth will be 1:2:4. To achieve this bandwidth allocation, each service flow is assigned a value known as its excess ratio which is derived from its DOCSIS priority. Table below shows the default mappings of DOCSIS priority to excess ratio.



**Note** When traffic priority for a flow is not explicitly specified, a default priority value of 0 is used as per the DOCSIS specification.

**Table 296: DOCSIS Priority to Excess Ratio Mapping**

| DOCSIS Traffic Priority | Excess Ratio |
|-------------------------|--------------|
| 0                       | 4            |
| 1                       | 8            |
| 2                       | 12           |
| 3                       | 16           |
| 4                       | 20           |

| DOCSIS Traffic Priority | Excess Ratio |
|-------------------------|--------------|
| 5                       | 24           |
| 6                       | 28           |
| 7                       | 32           |

### Custom DOCSIS Priority to Excess Ratio Mappings

This option is introduced to configure custom priority to excess ratio mappings for downstream service flows that override the default mappings listed in the above Table.



**Note** The configured values are used only for new service flows that are created after the configuration has been applied. All the existing service flows maintain their previous excess ratio values.

The option to configure priority to excess ratio mappings is available on a per downstream forwarding interface basis and is applicable to legacy cable, wideband and modular cable, and integrated cable interfaces.

The cable downstream qos wfq weights command is used to configure the mappings.

### Maximum Sustained Traffic Rate

The maximum sustained traffic rate (MSR) specifies the peak information rate of a service flow. The MSR of a service flow is mapped to the shape rate of the packet queue. When the maximum sustained traffic rate is not specified or set to zero, its traffic rate becomes limited only by the physical channel capacity set by DOCSIS specifications.



**Note** The Cisco cBR Cisco Packet Processor (CPP) forwarding processor supports a maximum ratio of 1,000:1 between the highest MaxSusRate or MinRsvRate and the lowest MaxSusRate or MinRsvRate. The scheduler is impacted when the ratio exceeds the value. This limitation is per downstream forwarding interface (Wideband-Cable, Integrated-Cable, and Downstream-Cable).

However, flows implemented by Low Latency Queuing (LLQ) are not be affected by this limitation.

### Minimum Reserved Traffic Rate

The minimum reserved traffic rate (MRR) specifies the minimum rate reserved for a service flow. The MRR of a service flow is mapped to the CIR of the packet queue, which ensures the minimum amount of bandwidth a queue gets under congestion. When the MRR is not specified, the CIR is set to zero as per DOCSIS specifications.

### High Priority Traffic

High priority traffic flows are mapped to a Low Latency Queue (LLQ) on the data forwarding interface. The packets in LLQ are serviced with absolute priority over other queues on the same interface.

The following service flows require high priority service:

- Service flows with DOCSIS downstream latency TLV set to a value above zero. For example, PacketCable Multimedia Specification (PCMM) voice calls.
- PacketCable downstream service flows.
- Service flows with Unsolicited Grant Service (UGS) type—non-PacketCable voice calls—upstream flows.

## Enhanced Rate Bandwidth Allocation

The DOCSIS WFQ Scheduler supports the Enhanced Rate Bandwidth Allocation (ERBA) feature for service flows. The ERBA feature allows cable modems (CMs) to burst their temporary transmission rates up to the full line rate for short durations of time. This capability provides higher bandwidth for instantaneous bandwidth requests without having to make changes to existing service levels in the QoS profile.

The DOCSIS WFQ Scheduler allows each service flow to have one dedicated queue. When ERBA is enabled for the service flow, the peak rate is implemented as the queue shape rate within the scheduler, while the maximum sustained rate is set as the token bucket refill rate. When ERBA is turned off, the burst size and the peak rate value are not used.

The maximum traffic burst parameter is used to control a service flow burst duration, to burst up to the channel line rate or a configured peak rate, when it is within its maximum burst size allowance. On the Cisco cBR-8 Converged Broadband Router, the **cable ds-max-burst** command is used to control this behavior explicitly.



**Note** The ERBA feature is not applicable for high priority service flows and multicast service flows.

Table below summarizes the ERBA support for the Cisco cBR-8 router.

**Table 297: Enhanced Rate Bandwidth Allocation Support for the Cisco cBR-8 Router**

|                           | <b>Policer Rate</b>                     | <b>Policer Exceed Action</b> | <b>Policer Token Bucket Size</b>             | <b>Queue Shape Rate</b>        |
|---------------------------|-----------------------------------------|------------------------------|----------------------------------------------|--------------------------------|
| Traditional Service Flow  | Maximum Sustained Traffic Rate (unused) | Transmit                     | A value computed internally by CMTS (unused) | Maximum Sustained Traffic Rate |
| ERBA-Enabled Service Flow | Maximum Sustained Traffic Rate          | Drop                         | Maximum Traffic Burst TLV                    | Peak Traffic Rate              |

For information about ERBA support on the Cisco CMTS routers, refer to Using Enhanced Bandwidth Rate Allocation (ERBA) Support for DOCSIS 1.0 Cable Modems at the following location: [DOCSIS 1.1 for the Cisco CMTS Routers](#)

### Peak Traffic Rate

The *peak-rate* option of the **cable ds-max-burst** command allows you to specify the peak rate an ERBA-enabled service flow can use. The *peak-rate* value is a global value and is applied to all service flows created after the configuration of the **cable ds-max-burst** command. The default value of the *peak-rate* is zero.

If the DOCSIS 3.0 TLV 25.27 is specified for a service flow, the *peak-rate* value is set as the TLV value. However, if ERBA is not turned on for a service flow, the *peak-rate* value is ignored.

The *peak-rate* value can also be configured through cable service class command which forms part of the service class template. During modem registration or Dynamic Service Addition (DSA) operation, the service class name TLV 25.4 is sent to create the static or dynamic downstream service flow that matches the service class template. These downstream service flows are created with a specific *peak-rate*. If the *peak-rate* is not specified in the cable modem's configuration file, then the peak rate specified by the **cable ds-max-burst burst-threshold threshold peak-rate peak rate** command is used.



---

**Note** The option to specify peak rate in the **cable ds-max-burst** command is not available on the Cisco cBR Series Converged Broadband routers.

---

If a service flow has both service class and TLV 25.27 defined *peak-rate*, then the *peak-rate* value specified in the TLV is used.

Some of the DOCSIS 1.x and DOCSIS 2.0 cable modems, which are not fully DOCSIS 1.x or DOCSIS 2.0 compliant, may fail to come online when they receive TLV 25.27 from the Cisco CMTS during registration. In order to overcome this you can configure the **cable service attribute withhold-TLVs command with the peak-rate** keyword to restrict sending of this TLV to non-DOCSIS 3.0 cable modems.

## DOCSIS 3.0 Downstream Bonding Support with Bonding Group Dynamic Bandwidth Sharing

DOCSIS 3.0 introduces the concept of downstream channel bonding. Each Bonding Group (BG) is made up of a collection of downstream channels, which can be used by one or more bonding groups. Each downstream channel can also serve as a primary channel in a MAC domain and carry non-bonded traffic, while being part of a BG.

Prior to DOCSIS 3.0 standards, the downstream service flows were associated with a single downstream interface, which in turn corresponded to a physical downstream on an RF channel. In DOCSIS 3.0, the downstream service flows are associated with the downstream bonding groups. These bonding groups can use multiple downstream RF channels.

DBS is the dynamic allocation of bandwidth for wideband (WB) and integrated cable (IC) interfaces sharing the same downstream channel. Due to the channel sharing nature of the bonding groups, the bandwidth available to bonding groups or non-bonded channels is not fixed. The bandwidth depends on the configuration and the traffic load on the WB or IC.



---

**Note** Bonding groups are implemented as WB interfaces and non-bonded channels as IC interfaces.

---

In the DBS mode, the bandwidth of the shared RF channels is dynamically allocated among the WB and IC interfaces. The DBS enables efficient use of the underlying RF channel bandwidth even in the presence of high burst traffic. The DBS is configured at the WB or IC interface level. By default, bandwidth for a WB or IC channel is statically allocated (non-DBS).

For information about DBS support on the Cisco CMTS routers, refer to the [Dynamic Bandwidth Sharing on the Cisco CMTS Router](#) feature.



# How to Configure DOCSIS WFQ Scheduler

You cannot configure the DOCSIS WFQ Scheduler feature as it is automatically loaded. The parameters that the schedule uses include the interface bandwidth and queue parameters.

This section describes the following required and optional procedures:

## Mapping DOCSIS Priority to Excess Ratio

This section describes how to map DOCSIS priorities to custom excess ratios for downstream service flows. These custom mappings will override the default mappings.

### Procedure

|               | Command or Action                                                                                                                                                                                                                                                                                                  | Purpose                                                                                                                                           |
|---------------|--------------------------------------------------------------------------------------------------------------------------------------------------------------------------------------------------------------------------------------------------------------------------------------------------------------------|---------------------------------------------------------------------------------------------------------------------------------------------------|
| <b>Step 1</b> | <b>enable</b><br><b>Example:</b><br>Router> enable                                                                                                                                                                                                                                                                 | Enables privileged EXEC mode. Enter your password if prompted.                                                                                    |
| <b>Step 2</b> | <b>configure terminal</b><br><b>Example:</b><br>Router# configure terminal                                                                                                                                                                                                                                         | Enters global configuration mode.                                                                                                                 |
| <b>Step 3</b> | <b>interface wideband-cable</b> <i>slot/subslot/port</i><br><i>:wideband-channel</i> or <b>interface integrated-cable</b><br><i>slot/subslot/port :rf-channel</i><br><b>Example:</b><br>Router(config)# <b>interface wideband-cable</b> 2/0/0:0<br>or<br>Router(config)# <b>interface integrated-cable</b> 1/0/0:0 | Enters interface configuration mode for the indicated cable downstream interface.                                                                 |
| <b>Step 4</b> | <b>cable downstream qos wfq weights {weight1...weight8}</b><br><b>Example:</b><br>Router(config-if)# <b>cable downstream qos wfq weights</b><br>10 20 30 40 50 60 70 80                                                                                                                                            | Configures the custom excess ratios for 8 priorities:<br><b>Note</b> The custom values are used only for new service flows and not existing ones. |
| <b>Step 5</b> | <b>end</b><br><b>Example:</b><br>Router(config-if)# <b>end</b>                                                                                                                                                                                                                                                     | Exits interface configuration mode and returns to privileged EXEC mode.                                                                           |

## Verifying the Downstream Queues Information

To verify the downstream queue information for a modem, use the **show cable modem** [*mac-address* |*ip-address*] **service-flow** command.

To check queue stats of all queues on an Integrated-Cable or Wideband-Cable interface, use the **show cable dp queue** *interface* command.

## Additional References

The following sections provide references related to the DOCSIS WFQ Scheduler feature.

### Technical Assistance

| Description                                                                                                                                                                                                                                                                                                                                                                                                                                                                                                                                                             | Link                                                                    |
|-------------------------------------------------------------------------------------------------------------------------------------------------------------------------------------------------------------------------------------------------------------------------------------------------------------------------------------------------------------------------------------------------------------------------------------------------------------------------------------------------------------------------------------------------------------------------|-------------------------------------------------------------------------|
| <p>The Cisco Support website provides extensive online resources, including documentation and tools for troubleshooting and resolving technical issues with Cisco products and technologies.</p> <p>To receive security and technical information about your products, you can subscribe to various services, such as the Product Alert Tool (accessed from Field Notices), the Cisco Technical Services Newsletter, and Really Simple Syndication (RSS) Feeds.</p> <p>Access to most tools on the Cisco Support website requires a Cisco.com user ID and password.</p> | <a href="http://www.cisco.com/support">http://www.cisco.com/support</a> |

## Feature Information for DOCSIS WFQ Scheduler

Use Cisco Feature Navigator to find information about the platform support and software image support. Cisco Feature Navigator enables you to determine which software images support a specific software release, feature set, or platform. To access Cisco Feature Navigator, go to the <https://cfng.cisco.com/> link. An account on the Cisco.com page is not required.



**Note** The following table lists the software release in which a given feature is introduced. Unless noted otherwise, subsequent releases of that software release train also support that feature.

**Table 298: Feature Information for DOCSIS WFQ Scheduler**

| Feature Name         | Releases                    | Feature Information                                                                                               |
|----------------------|-----------------------------|-------------------------------------------------------------------------------------------------------------------|
| DOCSIS WFQ scheduler | Cisco IOS XE Everest 16.6.1 | This feature was integrated into Cisco IOS XE Everest 16.6.1 on the Cisco cBR Series Converged Broadband Routers. |



## CHAPTER 93

# Fairness Across DOCSIS Interfaces

---

The Fairness Across DOCSIS Interfaces feature introduces an adaptive mechanism to effectively distribute reservable bandwidth for committed information rate (CIR) flows and fair bandwidth for best-effort (BE) service flows across adjacent bonding groups (BGs).

Your software release may not support all the features that are documented in this module. For the latest feature information and caveats, see the release notes for your platform and software release. The Feature Information Table at the end of this document provides information about the documented features and lists the releases in which each feature is supported.

Use Cisco Feature Navigator to find information about platform support and Cisco software image support. To access Cisco Feature Navigator, go to <http://tools.cisco.com/ITDIT/CFN/>. An account on <http://www.cisco.com/> is not required.

### Contents

- [Hardware Compatibility Matrix for the Cisco cBR Series Routers, on page 1479](#)
- [Prerequisites for Fairness Across DOCSIS Interfaces, on page 1481](#)
- [Restrictions for Fairness Across DOCSIS Interfaces, on page 1481](#)
- [Information About Fairness Across DOCSIS Interfaces, on page 1481](#)
- [How to Configure Fairness Across DOCSIS Interfaces, on page 1483](#)
- [Verifying the Fairness Across DOCSIS Interfaces, on page 1486](#)
- [Configuration Examples for Fairness Across DOCSIS Interfaces, on page 1489](#)
- [Additional References, on page 1491](#)
- [Feature Information for Fairness Across DOCSIS Interfaces, on page 1491](#)

## Hardware Compatibility Matrix for the Cisco cBR Series Routers



---

**Note** The hardware components that are introduced in a given Cisco IOS-XE Release are supported in all subsequent releases unless otherwise specified.

---

Table 299: Hardware Compatibility Matrix for the Cisco cBR Series Routers

| Cisco CMTS Platform                    | Processor Engine                                                                                                                                                                                  | Interface Cards                                                                                                                                                                                                                                                                                                                                                                                                                                                                                                                                                                                                                                                                                                                                                                                 |
|----------------------------------------|---------------------------------------------------------------------------------------------------------------------------------------------------------------------------------------------------|-------------------------------------------------------------------------------------------------------------------------------------------------------------------------------------------------------------------------------------------------------------------------------------------------------------------------------------------------------------------------------------------------------------------------------------------------------------------------------------------------------------------------------------------------------------------------------------------------------------------------------------------------------------------------------------------------------------------------------------------------------------------------------------------------|
| Cisco cBR-8 Converged Broadband Router | <p><b>Cisco IOS-XE Release 16.5.1 and Later Releases</b></p> <p>Cisco cBR-8 Supervisor:</p> <ul style="list-style-type: none"> <li>• PID—CBR-SUP-250G</li> <li>• PID—CBR-CCAP-SUP-160G</li> </ul> | <p><b>Cisco IOS-XE Release 16.5.1 and Later Releases</b></p> <p>Cisco cBR-8 CCAP Line Cards:</p> <ul style="list-style-type: none"> <li>• PID—CBR-LC-8D30-16U30</li> <li>• PID—CBR-LC-8D31-16U30</li> <li>• PID—CBR-RF-PIC</li> <li>• PID—CBR-RF-PROT-PIC</li> <li>• PID—CBR-CCAP-LC-40G</li> <li>• PID—CBR-CCAP-LC-40G-R</li> <li>• PID—CBR-CCAP-LC-G2-R</li> <li>• PID—CBR-SUP-8X10G-PIC</li> <li>• PID—CBR-2X100G-PIC</li> </ul> <p>Digital PICs:</p> <ul style="list-style-type: none"> <li>• PID—CBR-DPIC-8X10G</li> <li>• PID—CBR-DPIC-2X100G</li> </ul> <p>Cisco cBR-8 Downstream PHY Module:</p> <ul style="list-style-type: none"> <li>• PID—CBR-D31-DS-MOD</li> </ul> <p>Cisco cBR-8 Upstream PHY Modules:</p> <ul style="list-style-type: none"> <li>• PID—CBR-D31-US-MOD</li> </ul> |



**Note** Do not use DPICs (8X10G and 2x100G) to forward IP traffic, as it may cause buffer exhaustion, leading to line card reload.

The only allowed traffic on a DPIC interface is DEPI, UEPI, and GCP traffic from the Cisco cBR-8 router to Remote PHY devices. Other traffic such as DHCP, SSH, and UTSC should flow via another router, since DPICs cannot be used for normal routing.

# Prerequisites for Fairness Across DOCSIS Interfaces



---

**Note** The term ‘Bonding Group (BG)’ is used in this document to refer to all the integrated-cable (IC) and wideband-cable (WC) interfaces in the context of Fairness Across DOCSIS Interfaces feature context. The IC interfaces are considered as a single-channel BG.

---

## Restrictions for Fairness Across DOCSIS Interfaces

- The CIR flows cannot reserve all the RF bandwidth. The CIR flows can only reserve 90 percent<sup>6</sup> of the RF bandwidth that is not statically reserved by the “bandwidth-percent”, in addition to the legacy CIR bandwidth.
- It is recommended that the CIR reservation be cleared before disabling Fairness Across DOCSIS Interfaces feature to ensure that the CIR reservation is not more than the static reservable bandwidth specified by the “bandwidth-percent” in legacy configuration. This is to prevent CIR over-subscription after disabling Fairness Across DOCSIS Interfaces feature.
- The effect of Fairness Across DOCSIS Interfaces feature depends on topology and flow distribution. In certain cases, Fairness Across DOCSIS Interfaces feature may not achieve BE fairness or maximum CIR utilization.
- Fairness Across DOCSIS Interfaces feature applies only to dynamic bandwidth sharing (DBS) enabled IC and WB interfaces.

## Information About Fairness Across DOCSIS Interfaces

The Fairness Across DOCSIS Interfaces feature is an enhancement over the DOCSIS WFQ scheduler. It enables downstream CIR service flows to be admitted on the interfaces over the thresholds defined in the legacy configuration (that is, “bandwidth-percent” or “max-reserved-bandwidth”). For example, the feature enables large CIR flows (like multicast service flows) to be admitted when the current parameters cannot guarantee enough bandwidth. However, its success rate depends on the allocation and reservation of the bandwidth for cable interfaces within common RF channels.

This feature also ensures fair bandwidth for downstream BE service flows across cable interfaces with common RF channels. The per-flow bandwidth of all active service flows on the adjacent BGs are balanced periodically. The weights (DOCSIS traffic priority (traffic priority + 1)) of all the BGs are equal for downstream BE service flows. The bandwidth, available for BE traffic, can be used to admit additional CIR flows.



---

**Note** For information about DOCSIS traffic priority, see [DOCSIS WFQ Scheduler on the Cisco CMTS Routers guide](#).

---

<sup>6</sup> The reservable bandwidth for CIR flows consists of static and dynamic portions. By default, the static portion of bandwidth is assigned from the legacy configuration. The dynamic portion of bandwidth comes from the headroom left on each RF channel for BE traffic.

## On-demand CIR Acquisition

When multiple bonding groups sharing the RF-channel bandwidth and the current bonding group's guaranteed bandwidth is insufficient, this feature can "borrow" neighbor bonding group's non-reserved guaranteed bandwidth for current bonding group's CIR.

This feature is only used by multicast service flow.

## Fairness Across Bonding Groups

Fairness Across DOCSIS Interfaces feature use the weight value of the aggregated active flow count, that is EIR demand, to periodically re-balance the reservable bandwidth. So that the service flows with the same weight in different bonding groups will have roughly the same throughput.

## OFDM Channels

### OFDM Channel

DOCSIS 3.1 introduces modes for higher throughput and higher spectral efficiency while still allowing backward compatibility to DOCSIS 3.0. OFDM Channel support includes 1 OFDM channel per port with channel bandwidth from 24 MHz to 192 MHz wide. In Cisco IOS-XE 16.5.1, a bonding group can consist of SC-QAMs and OFDM channels. An OFDM channel can have multiple profiles configured, and each profile may have different rate. The OFDM Channel rate can vary constantly depending on the profiles being used. For more information on OFDM channels, see *OFDM Channel Configuration Guide*.

### OFDM Channel Rate

An OFDM channel can have multiple profiles configured, and each profile can have different rates. For example, with a 96MHz OFDM channel that is configured with profile A (Control Profile) with modulation 1024-QAM, profile B with modulation 2048-QAM, and profile C with modulation 4096-QAM, the profile rates of profile A, B, and C are 616Mbps, 680Mbps, and 736Mbps respectively.

In Cisco IOS-XE 16.5.1, if an OFDM channel has both Control Profile (profile A) and Data Profiles (profile B, C, and so on) configured, the lowest Data Profile rate is used for Fairness Across DOCSIS Interface calculation. Otherwise, the Control Profile rate is used.

## Interface Bandwidth

A Wideband-Cable (WB) interface can consist of both SC-QAMs and OFDM channels. If it contains OFDM channels, the highest profile rates are used to calculate the interface bandwidth.

For example, with a 96MHz OFDM channel that is configured with profile A having modulation 1024-QAM, profile B with modulation 2048-QAM, and profile C with modulation 4096-QAM, the profile rates of profile A, B, and C are 616Mbps, 680Mbps, and 736Mbps respectively. Here, 736Mbps is used to calculate the interface bandwidth.

# How to Configure Fairness Across DOCSIS Interfaces

This section describes the following tasks that are required to implement Fairness Across DOCSIS Interfaces feature:

## Configuring Fairness Across DOCSIS Interfaces

This section describes how to enable Fairness Across DOCSIS Interfaces feature on the cable interfaces. The configuration is applied to all WB or IC interfaces on the router.



**Restriction** We recommend that you clear the CIR reservation before disabling the Fairness Across DOCSIS Interfaces feature to ensure that CIR reservation is not more than the static reservable bandwidth specified by the “bandwidth-percent” in the legacy configuration.

### Procedure

|               | Command or Action                                                                | Purpose                                                                                                            |
|---------------|----------------------------------------------------------------------------------|--------------------------------------------------------------------------------------------------------------------|
| <b>Step 1</b> | <b>enable</b><br><b>Example:</b><br>Router> enable                               | Enables privileged EXEC mode. <ul style="list-style-type: none"> <li>• Enter your password if prompted.</li> </ul> |
| <b>Step 2</b> | <b>configure terminal</b><br><b>Example:</b><br>Router# configure terminal       | Enters global configuration mode.                                                                                  |
| <b>Step 3</b> | <b>cable acfe enable</b><br><b>Example:</b><br>Router(config)# cable acfe enable | Enables Fairness Across DOCSIS Interfaces feature on the cable interfaces.                                         |
| <b>Step 4</b> | <b>exit</b><br><b>Example:</b><br>Router(config)# exit                           | Exits global configuration mode and returns to privileged EXEC mode.                                               |

## Configuring Maximum Excess Information Rate Ratio

This section describes how to configure the maximum Excess Information Rate (EIR) ratio between the BE bandwidth among adjacent BGs.

The EIR ratio is used to maintain the maximum EIR bandwidth difference between BGs. It helps to prevent BGs (which has only a few active BE service flows) from getting very low or zero EIR bandwidth. Otherwise, these BGs will not be able to admit CIR flows as they get only very low EIR bandwidth.

For example, there are two BGs sharing the same RF channel, with BG1 having 1000 active BE service flows and BG2 having none. If “max-eir-ratio” is not used, BG1 gets all the bandwidth leaving no bandwidth for BG2. When a voice CIR tries for bandwidth at BG2, it will get rejected. If “max-eir-ratio” is set at 10, BG2 gets about 10 percent of the QAM that is sufficient to admit the voice CIR. The ‘max-eir-ratio’ is a trade-off between perfect fairness and CIR utilization. It means, compromising 'flow fairness' to prevent some BGs from getting all the bandwidth leaving the other BGs with none.

### Procedure

|               | Command or Action                                                                                                  | Purpose                                                                                                            |
|---------------|--------------------------------------------------------------------------------------------------------------------|--------------------------------------------------------------------------------------------------------------------|
| <b>Step 1</b> | <b>enable</b><br><b>Example:</b><br>Router> enable                                                                 | Enables privileged EXEC mode. <ul style="list-style-type: none"> <li>• Enter your password if prompted.</li> </ul> |
| <b>Step 2</b> | <b>configure terminal</b><br><b>Example:</b><br>Router# configure terminal                                         | Enters global configuration mode.                                                                                  |
| <b>Step 3</b> | <b>cable acfe max-eir-ratio <i>eir-ratio</i></b><br><b>Example:</b><br>Router(config)# cable acfe max-eir-ratio 20 | Configures the maximum EIR ratio between the BE bandwidth among adjacent BGs.                                      |
| <b>Step 4</b> | <b>exit</b><br><b>Example:</b><br>Router(config)# exit                                                             | Exits global configuration mode and returns to privileged EXEC mode.                                               |

## Configuring Constant Excess Information Rate Demand

This section describes how to configure the constant excess information rate (EIR) demand for a bonding group (BG). EIR demand is a unitless value that is used to determine relative bandwidth ratio between BGs.

An active EIR flow with DOCSIS priority-0 is given 1000 units of demand in ACFE module. Therefore a BG with constant-eir-demand set to 1 will get no more than 1/1000 of the bandwidth of a single service flow.

### SUMMARY STEPS

1. enable
2. configure terminal
3. cable acfe constant-eir-demand *value*
4. exit



## DETAILED STEPS

|        | Command or Action                                                                                                          | Purpose                                                                                                            |
|--------|----------------------------------------------------------------------------------------------------------------------------|--------------------------------------------------------------------------------------------------------------------|
| Step 1 | <b>enable</b><br><b>Example:</b><br>Router> enable                                                                         | Enables privileged EXEC mode. <ul style="list-style-type: none"> <li>• Enter your password if prompted.</li> </ul> |
| Step 2 | <b>configure terminal</b><br><b>Example:</b><br>Router# configure terminal                                                 | Enters global configuration mode.                                                                                  |
| Step 3 | <b>cable acfe constant-eir-demand <i>value</i></b><br><b>Example:</b><br>Router(config)# cable acfe constant-eir-demand 20 | Configures the constant EIR demand as 20 for a BG.                                                                 |
| Step 4 | <b>exit</b><br><b>Example:</b><br>Router(config)# exit                                                                     | Exits global configuration mode and returns to privileged EXEC mode.                                               |

## Configuring Maximum Bonus Bandwidth

This section describes how to configure the maximum usable bonus bandwidth for a BG.

Bonus bandwidth is the additional bandwidth provided by the Fairness Across DOCSIS Interfaces feature to each BG for CIR reservation. In the default maximum bonus bandwidth configuration, a single BG can reserve all the underlying RF bandwidth. When the maximum bonus is set, the AC module will not admit CIR flows above that setting even if the scheduler has guaranteed more bandwidth. This will effectively prevent BGs from being starved for CIR flows.



**Note** The **cable acfe max-bonus-bandwidth** command configuration is applicable only for the new incoming CIR flows. It will not terminate the existing CIR flows that exceeds the **max-bonus-bandwidth** .



**Restriction** If the maximum bonus bandwidth is less than the current CIR reservation on an interface, no new CIR flows are admitted until the CIR reservation drops below the maximum bonus bandwidth configuration.

### Procedure

|        | Command or Action | Purpose                       |
|--------|-------------------|-------------------------------|
| Step 1 | enable            | Enables privileged EXEC mode. |

|               | Command or Action                                                                                                                                                       | Purpose                                                                                                                                                                                                                                                     |
|---------------|-------------------------------------------------------------------------------------------------------------------------------------------------------------------------|-------------------------------------------------------------------------------------------------------------------------------------------------------------------------------------------------------------------------------------------------------------|
|               | <b>Example:</b><br><pre>Router&gt; enable</pre>                                                                                                                         | <ul style="list-style-type: none"> <li>Enter your password if prompted.</li> </ul>                                                                                                                                                                          |
| <b>Step 2</b> | <b>configure terminal</b><br><b>Example:</b><br><pre>Router# configure terminal</pre>                                                                                   | Enters global configuration mode.                                                                                                                                                                                                                           |
| <b>Step 3</b> | <b>interface {wideband-cable   interface-cable }slot/subslot /port :interface-num</b><br><b>Example:</b><br><pre>Router(config)# interface wideband-cable 1/0/0:0</pre> | Specifies the interface to be configured.<br><b>Note</b> The valid values for the arguments depend on CMTS router and cable interface line card. See the hardware documentation for your router chassis and cable interface line card for supported values. |
| <b>Step 4</b> | <b>cable acfe max-bonus-bandwidth bonus-bandwidth</b><br><b>Example:</b><br><pre>Router(config-if)# cable acfe max-bonus-bandwidth 1000000</pre>                        | Configures the maximum usable bonus bandwidth for a BG.                                                                                                                                                                                                     |
| <b>Step 5</b> | <b>end</b><br><b>Example:</b><br><pre>Router(config)# end</pre>                                                                                                         | Exits interface configuration mode and returns to privileged EXEC mode.                                                                                                                                                                                     |

## Verifying the Fairness Across DOCSIS Interfaces

To monitor the Fairness Across DOCSIS Interfaces feature, use the following procedures:

### Verifying Reservable Bandwidth

To display the reserved and reservable bandwidth for a particular interface, use the **show interface {wideband-cable | modular-cable | integrated-cable}** command as shown in the example:

```
Router# show interfaces wideband-cable 1/0/0:1 downstream
Total downstream bandwidth 1875 Kbps
Total downstream reserved/reservable bandwidth 20000/1500 Kbps
Total downstream guaranteed/non-guaranteed bonus bandwidth 20760/9741 Kbps
Router#
```

The “reservable bandwidth” is a part of the guaranteed bandwidth from the legacy configuration. When the Fairness Across DOCSIS Interfaces feature is disabled, values of both the “guaranteed bonus bandwidth” and “non-guaranteed bonus bandwidth” is zero. When the feature is enabled, the “reservable bandwidth” and “guaranteed bonus bandwidth” represents the maximum CIR that can be reserved on the interface. Unicast CIR flows exceeding this limit are rejected. The additional “non-guaranteed bonus bandwidth” allows the

multicast CIR flows to pass the AC module. However, the service flow may not be created successful because the bandwidth comes from the shared pool.

To display the reserved and reservable bandwidth for a particular interface, use the **show cable admission-control interface** command as shown in the example:

```
Router#show cable admission-control interface wideband-Cable 1/0/0:0

Interface Wi1/0/0:0
BGID: 28673

Resource - Downstream Bandwidth
-----
App-type   Name           Reservation/bps  Exclusive
1          0              0                Not configured
2          0              0                Not configured
3          0              0                Not configured
4          0              0                Not configured
5          0              0                Not configured
6          0              0                Not configured
7          0              0                Not configured
8          20000000      0                Not configured
Max Reserved BW = 1500000 bps
Total Current Reservation = 20000000 bps
Guaranteed Bonus BW = 20760000 bps
Non-guaranteed Bonus BW = 9741000 bps
Subset BGs: In1/0/0:8 In1/0/0:9 In1/0/0:10 In1/0/0:11 In1/0/0:12
Superset BGs: N/A
Overlapping BGs: Wi1/0/0:8 Wi1/0/0:9 Wi1/0/0:10
Router#
```

Effective with Cisco IOS-XE Release 3.18.0SP, Capacity BW is also displayed. It is a summation of the channel capacity of the RF channels in this interface, and the capacity of OFDM channels is calculated considering the lowest profile rate.

```
Router#show cable admission-control interface wideband-Cable 2/0/0:1

Interface Wi2/0/0:1
BGID: 8194

Resource - Downstream Bandwidth
-----
App-type   Name           Reservation/bps  Maximum    Rejected
1          4000           4000            90%        0
2          0              0                N/A        0
3          0              0                90%        0
4          0              0                N/A        0
5          0              0                N/A        0
6          0              0                90%        0
7          0              0                N/A        0
8          0              0                87%        0
Max Reserved BW = 11424000 bps
Total Current Reservation = 4000 bps
Guaranteed Bonus BW = 884352000 bps
Non-guaranteed Bonus BW = 225904000 bps
Capacity BW = 1428000000 bps
Subset BGs: In2/0/0:0 In2/0/0:1 In2/0/0:2 In2/0/0:3 In2/0/0:4 In2/0/0:5 In2/0/0:6 In2/0/0:7
             In2/0/0:158 Wi2/0/0:0
Superset BGs: N/A
```

## Verifying Global Fairness Across DOCSIS Interfaces Status and Statistics

To display the global status and statistics of the Fairness Across DOCSIS Interfaces feature, use the **show cable acfe summary** command as shown in the example:

```
Router# show cable acfe summary
ACFE state: Enabled
EIR Rebalance period (secs): 5
EIR Rebalance invocations: 254
CIR Acquire rate/limit: 100/100
CIR Acquire invocations: 0
CIR Acquire throttled: 0
CIR Oversubscriptions: 0
Maximal EIR ratio: 10
Constant EIR demand: 2
```

## Verifying Per-Controller Fairness Across DOCSIS Interfaces Status and Statistics

To display the status and statistics for each controller interface, use the **show cable acfe controller** command as shown in the following example:

```
Router# show cable acfe controller integrated-Cable 1/0/0
EIR Rebalance invoked: 450963
Adaptive CIR granted: 20
Adaptive CIR rejected: 1
Total clusters: 9
RF FlexBW
8 36376
9 36376
10 32625
.....
```

The BG clusters span across multiple channels and are used as a means to share the underlying RF channel bandwidth dynamically.

Use the **show controllers integrated-Cable acfe cluster** command to show Per-controller statistics and clusters and checking the bandwidth information as follows:

```
Router# show controllers integrated-Cable 1/0/0 acfe cluster 0
Integrated-Cable 1/0/0 status:
Topology changed: No

=====Cluster 0=====
Number of RF: 2
RF FlexBW  WB  ExcessBW  Quanta
0 35625  -   35438  35438
           0   187   187
1 35250  0  35250  35250

Number of BG: 2
Intf Demand CIR Max  CstrMin Alloc NBonus Ratio
WB0 1000 0 70875 35250 35437 35438 14855190400
IC0 1000 0 35625 0 35438 187 14855609600
```

## Verifying Per-Interface Fairness Across DOCSIS Interfaces Status and Statistics

To display the status and statistics for each interface, use the **show cable acfe interface** command as shown in the following example:

```
Router# show cable acfe interface wideband-cable 1/0/0:1
EIR Demand (raw/scale): 0/1
Per-Flow EIR BW (kbps): 19125
Guar Bonus BW (kbps): 19125
Non-guar Bonus BW (kbps): 38250
Reserved Bonus BW (kbps): 0
!
```

## Configuration Examples for Fairness Across DOCSIS Interfaces

This section lists the following sample configurations for the Fairness Across DOCSIS Interfaces feature on a Cisco CMTS router:

### Example: Fairness Across DOCSIS Interfaces

The following sample configuration shows Fairness Across DOCSIS Interfaces feature enabled on the router:

```
Current configuration : 39682 bytes
!
! Last configuration change at 04:30:02 UTC Wed Jan 19 2
! NVRAM config last updated at 04:23:17 UTC Wed Jan 19 2
!
version 12.2
!
cable clock dti
cable acfe enable
!
.
.
.
```

### Example: Maximum EIR Demand Ratio

The following sample configuration shows maximum EIR demand ratio configured on the router:

```
Building configuration...
Current configuration : 54253 bytes
!
version 12.2
!
cable clock dti
cable acfe enable
cable acfe max-eir-ratio 20
!
```

The effect of the **cable acfe max-eir-ratio** command is demonstrated using a simple BG cluster.

```
!
interface integrated-Cable1/0/0:0
```

```

cable bundle 1
  cable rf-bandwidth-percent 10
!
interface Wideband-Cable9/0/0:0
  cable bundle 1
  cable rf-channels channel-list 0
  bandwidth-percent 1
  end
!

```

On this RF channel, 20 percent of the bandwidth is reserved by the ‘bandwidth-percent’ allowing Fairness Across DOCSIS Interfaces feature to use 27 Mbps, that is:  $(100 - 20) * 90 * 37.5$ . If the ‘max-eir-ratio’ is above 100 and the WB interface has 99 active BE flows and the IC interface has only 1 BE flow, then IC interface gets only 270 kbps, that is  $1/(1+99)*27$  of the bonus bandwidth. The BE traffic enjoys perfect fairness here. However, it is not possible to admit a unicast CIR flow beyond 270 kbps on the IC interface, as it would exceed the bonus bandwidth. If the ‘max-eir-ratio’ is set to 10, then the IC interface is treated to have 99/10 flows on it, resulting in a higher bonus bandwidth allocation. The ‘max-eir-ratio’ is a trade-off between perfect fairness and CIR utilization.

## Example: Constant EIR Demand

The following sample configuration shows constant EIR demand on the router:

```

Building configuration...
Current configuration : 54253 bytes
!
version 12.2
!
cable clock dti
cable acfe enable
cable acfe max-eir-ratio 20
cable acfe constant-eir-demand 2
!

!
interface integrated-Cable1/0/0:0
cable bundle 1
  cable rf-bandwidth-percent 10
  cable acfe constant-eir-demand 2
!
interface Wideband-Cable9/0/0:0
cable bundle 1
  cable rf-channels channel-list 0
  bandwidth-percent 1
  cable acfe constant-eir-demand 2
  end
!

```

## Example: Maximum Bonus Bandwidth

The following sample configuration shows the maximum bonus bandwidth enabled on the router:

```

Building configuration...
Current configuration : 274 bytes
!
interface Wideband-Cable1/0/0:0
cable bundle 1

```

```

cable rf-channel 0 bandwidth-percent 10
cable acfe max-bonus-bandwidth 10000
end
!
```

In this per-interface configuration, even if the Fairness Across DOCSIS Interfaces feature guarantees more than 10 Mbps for a WB interface, the AC module will not pass more than 10 Mbps bandwidth above the legacy reservable bandwidth.

```

!
.
.
.
```

## Additional References

### Technical Assistance

| Description                                                                                                                                                                                                                                                                                                                                                                                                                                                                                                                                                             | Link                                                                    |
|-------------------------------------------------------------------------------------------------------------------------------------------------------------------------------------------------------------------------------------------------------------------------------------------------------------------------------------------------------------------------------------------------------------------------------------------------------------------------------------------------------------------------------------------------------------------------|-------------------------------------------------------------------------|
| <p>The Cisco Support website provides extensive online resources, including documentation and tools for troubleshooting and resolving technical issues with Cisco products and technologies.</p> <p>To receive security and technical information about your products, you can subscribe to various services, such as the Product Alert Tool (accessed from Field Notices), the Cisco Technical Services Newsletter, and Really Simple Syndication (RSS) Feeds.</p> <p>Access to most tools on the Cisco Support website requires a Cisco.com user ID and password.</p> | <a href="http://www.cisco.com/support">http://www.cisco.com/support</a> |

## Feature Information for Fairness Across DOCSIS Interfaces

Use Cisco Feature Navigator to find information about the platform support and software image support. Cisco Feature Navigator enables you to determine which software images support a specific software release, feature set, or platform. To access Cisco Feature Navigator, go to the <https://cfng.cisco.com/> link. An account on the Cisco.com page is not required.



**Note** The following table lists the software release in which a given feature is introduced. Unless noted otherwise, subsequent releases of that software release train also support that feature.

*Table 300: Feature Information for Downstream Interface Configuration*

| <b>Feature Name</b>               | <b>Releases</b>             | <b>Feature Information</b>                                                                                        |
|-----------------------------------|-----------------------------|-------------------------------------------------------------------------------------------------------------------|
| Fairness across DOCSIS interfaces | Cisco IOS XE Everest 16.6.1 | This feature was integrated into Cisco IOS XE Everest 16.6.1 on the Cisco cBR Series Converged Broadband Routers. |





## CHAPTER 94

# Service Group Admission Control

---

This document describes the Service Group Admission Control feature.

- [Finding Feature Information](#), on page 1493
- [Hardware Compatibility Matrix for the Cisco cBR Series Routers](#), on page 1493
- [Restrictions for Service Group Admission Control](#), on page 1494
- [Information About Service Group Admission Control](#), on page 1495
- [How to Configure, Monitor, and Troubleshoot Service Group Admission Control](#), on page 1497
- [Configuration Examples for SGAC](#), on page 1502
- [Additional References](#), on page 1505
- [Feature Information for Service Group Admission Control](#), on page 1506

## Finding Feature Information

Your software release may not support all the features documented in this module. For the latest caveats and feature information, see [Bug Search Tool](#) and the release notes for your platform and software release. To find information about the features documented in this module, and to see a list of the releases in which each feature is supported, see the feature information table.

Use Cisco Feature Navigator to find information about platform support and Cisco software image support. To access Cisco Feature Navigator, go to <https://cfng.cisco.com/>. An account on Cisco.com is not required.

## Hardware Compatibility Matrix for the Cisco cBR Series Routers



---

**Note** The hardware components that are introduced in a given Cisco IOS-XE Release are supported in all subsequent releases unless otherwise specified.

---

Table 301: Hardware Compatibility Matrix for the Cisco cBR Series Routers

| Cisco CMTS Platform                    | Processor Engine                                                                                                                                                                                  | Interface Cards                                                                                                                                                                                                                                                                                                                                                                                                                                                                                                                                                                                                                                                                                                                                                                                 |
|----------------------------------------|---------------------------------------------------------------------------------------------------------------------------------------------------------------------------------------------------|-------------------------------------------------------------------------------------------------------------------------------------------------------------------------------------------------------------------------------------------------------------------------------------------------------------------------------------------------------------------------------------------------------------------------------------------------------------------------------------------------------------------------------------------------------------------------------------------------------------------------------------------------------------------------------------------------------------------------------------------------------------------------------------------------|
| Cisco cBR-8 Converged Broadband Router | <p><b>Cisco IOS-XE Release 16.5.1 and Later Releases</b></p> <p>Cisco cBR-8 Supervisor:</p> <ul style="list-style-type: none"> <li>• PID—CBR-SUP-250G</li> <li>• PID—CBR-CCAP-SUP-160G</li> </ul> | <p><b>Cisco IOS-XE Release 16.5.1 and Later Releases</b></p> <p>Cisco cBR-8 CCAP Line Cards:</p> <ul style="list-style-type: none"> <li>• PID—CBR-LC-8D30-16U30</li> <li>• PID—CBR-LC-8D31-16U30</li> <li>• PID—CBR-RF-PIC</li> <li>• PID—CBR-RF-PROT-PIC</li> <li>• PID—CBR-CCAP-LC-40G</li> <li>• PID—CBR-CCAP-LC-40G-R</li> <li>• PID—CBR-CCAP-LC-G2-R</li> <li>• PID—CBR-SUP-8X10G-PIC</li> <li>• PID—CBR-2X100G-PIC</li> </ul> <p>Digital PICs:</p> <ul style="list-style-type: none"> <li>• PID—CBR-DPIC-8X10G</li> <li>• PID—CBR-DPIC-2X100G</li> </ul> <p>Cisco cBR-8 Downstream PHY Module:</p> <ul style="list-style-type: none"> <li>• PID—CBR-D31-DS-MOD</li> </ul> <p>Cisco cBR-8 Upstream PHY Modules:</p> <ul style="list-style-type: none"> <li>• PID—CBR-D31-US-MOD</li> </ul> |



**Note** Do not use DPICs (8X10G and 2x100G) to forward IP traffic, as it may cause buffer exhaustion, leading to line card reload.

The only allowed traffic on a DPIC interface is DEPI, UEPI, and GCP traffic from the Cisco cBR-8 router to Remote PHY devices. Other traffic such as DHCP, SSH, and UTSC should flow via another router, since DPICs cannot be used for normal routing.

## Restrictions for Service Group Admission Control

- To configure SGAC, the Fairness Across DOCSIS Interfaces feature must be enabled.

- SGAC supports downstream only.

# Information About Service Group Admission Control

## Overview

Service Group Admission Control (SGAC) is a mechanism that gracefully manages service group based admission requests when one or more resources are not available to process and support the incoming service request. Lack of such a mechanism not only causes the new request to fail with unexpected behavior but could potentially cause the flows that are in progress to have quality related problems. SGAC monitors such resources constantly, and accepts or denies requests based on resource availability.

SGAC enables you to provide a reasonable guarantee about the Quality of Service (QoS) to subscribers at the time of call admission, and to enable graceful degradation of services when resource consumption approaches critical levels. SGAC reduces the impact of unpredictable traffic demands in circumstances that would otherwise produce degraded QoS for subscribers.



---

**Note** SGAC begins graceful degradation of service when either a critical threshold is crossed, or when bandwidth is nearly consumed on the Cisco CMTS, depending on the resource being monitored.

---

SGAC enables you to configure thresholds for each resource on the Cisco CMTS. These thresholds are expressed in a percentage of maximum allowable resource utilization. Alarm traps may be sent each time a threshold is crossed for a given resource.

For downstream (DS) channels, you can configure the bandwidth allocation with thresholds for each fiber node.

## SGAC and Downstream Bandwidth Utilization

SGAC allows you to control the bandwidth usage for various DOCSIS traffic types or application types. The application types are defined by the user using a CLI to categorize the service flow.

### Categorization of Service Flows

The SGAC feature allows you to allocate the bandwidth based on the application types. Flow categorization allows you to partition bandwidth in up to eight application types or buckets. The composition of a bucket is defined by the command-line interface (CLI), as is the definition of rules to categorize service flows into one of these eight application buckets. Various attributes of the service flow may be used to define the rules.

For flows created by PacketCable, the following attributes may be used:

- The priority of the Packetcable gate associated with the flow (high or normal)

For flows created by PacketCable MultiMedia (PCMM), the following attributes may be used:

- Priority of the gate (0 to 7)
- Application type (0 to 65535)

All flows use the following attribute type:

- Service class name

Before a service flow is admitted, it is passed through the categorization routine. Various attributes of the service flow are compared with the user-configured rules. Based on the match, the service flow is labeled with application type, from 1 to 8. The bandwidth allocation is then performed per application type.

Before a service flow is admitted, it is categorized based on its attributes. The flow attributes are compared against CLI-configured rules, one bucket at a time. If a match is found for any one of the rules, the service flow is labeled for that bucket, and no further check is performed.

Bucket 1 rules are scanned first and bucket 8 rules are scanned last. If two different rules match two different buckets for the same service flow, the flow gets categorized under the first match. If no match is found, the flow is categorized as Best Effort (BE) and the bucket with best effort rule is labelled to the flow. By default, the BE bucket is bucket 8.

## Thresholds for Downstream Bandwidth

SGAC monitors downstream bandwidth consumption using the configured maximum reserved bandwidth. It rejects service flows with a non-zero minimal rate that would make the total reserved bandwidth exceed the configured threshold.

### Flexible Bandwidth Allocation

To address the issue of restricted bandwidth allocation for different application types, admission control can be applied for both normal priority and emergency voice flows. This is done by extending the threshold and assigning a group of application types in a fiber node. Each downstream service flow continues to be categorized for a single application type. However, the one-to-one mapping between an application type and a threshold no longer exists.

Each configured threshold and its associated group of application types can thus be treated as a constraint. A service flow categorized to a certain application type must pass all the constraints associated with that application type.

## Overview of Bonding Group Admission Control

DOCSIS 3.0 introduced bonded channels or bonding groups that allow a single cable modem to send data over multiple RF channels achieving higher throughput. These bonding groups are defined for both upstream and downstream channels. Bonding groups are created by combining multiple RF channels. A single RF channel may also be shared by multiple bonding groups.



---

**Note** Effective from Cisco IOS-XE 3.18.0SP Release, as per DOCSIS 3.1, if bonding group contains an OFDM channel, the bonding group's total bandwidth that can be reserved (its capacity), is calculated using the least efficient OFDM profile it can use.

---

Bonding group SGAC functionality allows to define the maximum reserved bandwidth for an application-type as a fraction of the available bandwidth. This fraction of the bandwidth is defined as a percentage value of the total bandwidth that can be reserved.

# How to Configure, Monitor, and Troubleshoot Service Group Admission Control

Configuration procedures are optional because the default configurations are enabled by default. This section presents a sequence of procedures for non-default configurations, monitoring and debugging procedures for both the default or non-default operations of SGAC.

## Defining Rules for Service Flow Categorization

This procedure describes how to configure service flow categorization rules on the Cisco CMTS. This flexible procedure changes default global service flow rules with variations of the **cable application type include** command.

Any one or several of these steps or commands may be used, in nearly any combination, to set or re-configure SGAC on the Cisco CMTS.



**Note** Application rules for SGAC are global configurations, and downstream bandwidth resources use the same sets of service flow rules.

### Procedure

|        | Command or Action                                                                                                                                                                                | Purpose                                                                                                                                                                                                             |
|--------|--------------------------------------------------------------------------------------------------------------------------------------------------------------------------------------------------|---------------------------------------------------------------------------------------------------------------------------------------------------------------------------------------------------------------------|
| Step 1 | <b>enable</b><br><b>Example:</b><br>Router> <b>enable</b>                                                                                                                                        | Enables privileged EXEC mode. <ul style="list-style-type: none"> <li>• Enter your password if prompted.</li> </ul>                                                                                                  |
| Step 2 | <b>configure terminal</b><br><b>Example:</b><br>Router# <b>configure terminal</b>                                                                                                                | Enters global configuration mode.                                                                                                                                                                                   |
| Step 3 | <b>cable application-type <i>n</i> include packetcable { normal   priority }</b><br><b>Example:</b><br>Router(config)# <b>cable application-type 5 include packetcable priority</b>              | For PacketCable, this command variation maps PacketCable service flow attributes to the specified bucket. PacketCable service flows are associated with PacketCable gates. The gate can be normal or high-priority. |
| Step 4 | <b>cable application-type <i>n</i> include pcmm {priority gate-priority / app-id gate-app-id }</b><br><b>Example:</b><br>Router(config)# <b>cable application-type 2 include pcmm priority 7</b> | For PCMM, this command variation maps PCMM service flow priority or application to the specified bucket. The PCMM gates are characterized by a priority level and by an application identifier.                     |

|               | Command or Action                                                                                                                                                                                      | Purpose                                                                                                                                                                                                                                                                                                                                                                                                                                                                                                                                                                                                                                                                                                                                                                                                                                                                                                                                                                                                                                                                                                                                                                                                                                                                                                  |
|---------------|--------------------------------------------------------------------------------------------------------------------------------------------------------------------------------------------------------|----------------------------------------------------------------------------------------------------------------------------------------------------------------------------------------------------------------------------------------------------------------------------------------------------------------------------------------------------------------------------------------------------------------------------------------------------------------------------------------------------------------------------------------------------------------------------------------------------------------------------------------------------------------------------------------------------------------------------------------------------------------------------------------------------------------------------------------------------------------------------------------------------------------------------------------------------------------------------------------------------------------------------------------------------------------------------------------------------------------------------------------------------------------------------------------------------------------------------------------------------------------------------------------------------------|
|               | Router(config)# <b>cable application-type 2 include pcmm app-id 152</b>                                                                                                                                |                                                                                                                                                                                                                                                                                                                                                                                                                                                                                                                                                                                                                                                                                                                                                                                                                                                                                                                                                                                                                                                                                                                                                                                                                                                                                                          |
| <b>Step 5</b> | <p><b>cable application-type <i>n</i> include service-class <i>service-class-name</i></b></p> <p><b>Example:</b></p> <pre>Router(config)# cable application-type 1 include service-class stream1</pre> | <p>For service class parameters, this command variation applies a service class name to the service flows, and applies corresponding QoS parameters.</p> <p>DOCSIS 1.1 introduced the concept of service classes. A service class is identified by a service class name. A service class name is a string that the Cisco CMTS associates with a QoS parameter set. One of the objectives of using a service class is to allow the high level protocols to create service flows with the desired QoS parameter set. Using a service class is a convenient way to bind the application with the service flows. The rules provide a mechanism to implement such binding.</p> <p>Note the following factors when using the command in this step:</p> <ul style="list-style-type: none"> <li>• Service classes are separately configured using the <b>cable service class</b> command to define the service flow.</li> <li>• A named service class may be classified into any application type.</li> <li>• Up to ten service class names may be configured per application types. Attempting to configure more than ten service classes prints an error message.</li> <li>• Use the <b>no cable traffic-type</b> command to remove the configuration of a service class before adding a new class.</li> </ul> |
| <b>Step 6</b> | <p><b>cable application-type <i>n</i> include BE</b></p> <p><b>Example:</b></p> <pre>Router# cable application-type 3 include BE</pre>                                                                 | <p>For Best Effort service flows, this command variation elaborates on Step 3, and changes the default bucket of 8 for Best Effort service flows with non-zero Committed Information Rate (CIR). These BE service flows are often created during cable modem registration.</p>                                                                                                                                                                                                                                                                                                                                                                                                                                                                                                                                                                                                                                                                                                                                                                                                                                                                                                                                                                                                                           |
| <b>Step 7</b> | <p><b>Ctrl-Z</b></p> <p><b>Example:</b></p> <pre>Router(config)# Ctrl^Z</pre>                                                                                                                          | <p>Returns to Privileged EXEC mode.</p>                                                                                                                                                                                                                                                                                                                                                                                                                                                                                                                                                                                                                                                                                                                                                                                                                                                                                                                                                                                                                                                                                                                                                                                                                                                                  |

### Example

The following example maps high-priority PacketCable service flows into application bucket 5.

```
Router(config)# cable application-type 5 include packetcable priority
```

The following example maps normal PacketCable service flows into application bucket 1.

```
Router(config)# cable application-type 1 include packetcable normal
```

The following example maps the specified bucket number with PCMM service flow with a priority of 7, then maps an application identifier of 152 for the same bucket number:

```
Router(config)# cable application-type 2 include pcmm priority 7
Router(config)# cable application-type 2 include pcmm app-id 152
```

The following example maps the Best Effort CIR flows to bucket 3:

```
Router(config)# cable application-type 3 include BE
```

## Naming Application Buckets

This procedure enables you to assign alpha-numeric names to six of the eight application buckets that SGAC supports. The default bucket identifiers range from 1 to 8.

### Procedure

|        | Command or Action                                                                                                                                               | Purpose                                                                                                                                                                                              |
|--------|-----------------------------------------------------------------------------------------------------------------------------------------------------------------|------------------------------------------------------------------------------------------------------------------------------------------------------------------------------------------------------|
| Step 1 | <p><b>enable</b></p> <p><b>Example:</b></p> <pre>Router&gt; enable</pre>                                                                                        | <p>Enables privileged EXEC mode.</p> <ul style="list-style-type: none"> <li>• Enter your password if prompted.</li> </ul>                                                                            |
| Step 2 | <p><b>configureterminal</b></p> <p><b>Example:</b></p> <pre>Router# configure terminal</pre>                                                                    | <p>Enters global configuration mode.</p>                                                                                                                                                             |
| Step 3 | <p><b>cable application-type <i>nname</i> <i>bucket-name</i></b></p> <p><b>Example:</b></p> <pre>Router(config)# cable application-type 7 name besteffort</pre> | <p>Assigns an alpha-numeric name for the specified bucket.</p> <p><b>Note</b> This bucket name appears in supporting <b>show</b> and <b>debug</b> commands along with the default bucket number.</p> |
| Step 4 | <p>Ctrl-Z</p> <p><b>Example:</b></p> <pre>Router(config)# Ctrl^Z</pre>                                                                                          | <p>Returns to Privileged EXEC mode.</p>                                                                                                                                                              |

## Preempting High-Priority Emergency 911 Calls

You may configure SGAC rules and thresholds so that the high-priority voice (911) traffic receives an exclusive share of bandwidth. Because the average call volume for Emergency 911 traffic may not be very high, the fraction of bandwidth reserved for Emergency 911 calls may be small. In the case of regional emergency, the

call volume of Emergency 911 calls may surge. In this case, it may be necessary to preempt some of the normal voice traffic to make room for surging Emergency 911 calls.

The Cisco CMTS software preempts one or more normal-priority voice flows to make room for the high-priority voice flows. SGAC provides the command-line interface (CLI) to enable or disable this preemption ability.

SGAC preemption logic follows the following steps:

1. When the first pass of admission control fails to admit a high priority PacketCable flow, it checks if it is possible to admit the flow in another bucket configured for normal PacketCable calls (applicable only if the PacketCable normal and high-priority rules are configured for different buckets). If the bandwidth is available, the call is admitted in the normal priority bucket.
2. If there is no room in normal priority bucket, it preempts a normal priority PacketCable flow and admits the high priority flow in the bucket where the low priority flow was preempted.
3. If there is no normal priority flow that it can preempt, it rejects the admission for high-priority flow. This usually happens when both normal and high-priority buckets are filled with 911 flows.

This preemption is effective only for PacketCable high-priority flows.

When a downstream low-priority service flow is chosen for preemption, the corresponding service flow for the same voice call in the opposite direction gets preempted as well.

### Procedure

|        | Command or Action                                                                                                                                           | Purpose                                                                                                                                                                                                                                                                                                                                                                                         |
|--------|-------------------------------------------------------------------------------------------------------------------------------------------------------------|-------------------------------------------------------------------------------------------------------------------------------------------------------------------------------------------------------------------------------------------------------------------------------------------------------------------------------------------------------------------------------------------------|
| Step 1 | <b>enable</b><br><b>Example:</b><br>Router> <b>enable</b>                                                                                                   | Enables privileged EXEC mode. <ul style="list-style-type: none"> <li>• Enter your password if prompted.</li> </ul>                                                                                                                                                                                                                                                                              |
| Step 2 | <b>configure terminal</b><br><b>Example:</b><br>Router# <b>configure terminal</b>                                                                           | Enters global configuration mode.                                                                                                                                                                                                                                                                                                                                                               |
| Step 3 | <b>[ no ] cable admission-control preempt priority-voice</b><br><b>Example:</b><br>Router(config)# <b>no cable admission-control preempt priority-voice</b> | Changes the default Emergency 911 call preemption functions on the Cisco CMTS, supporting throughput and bandwidth requirements for Emergency 911 calls above all other buckets on the Cisco CMTS.<br><br>The <b>no</b> form of this command disables this preemption, and returns the bucket that supports Emergency 911 calls to default configuration and normal function on the Cisco CMTS. |
| Step 4 | <b>Ctrl-Z</b><br><b>Example:</b><br>Router(config)# <b>Ctrl^Z</b><br>Router#                                                                                | Returns to Privileged EXEC mode.                                                                                                                                                                                                                                                                                                                                                                |



## Calculating Bandwidth Utilization

The SGAC feature maintains a counter for every US and DS channel, and this counter stores the current bandwidth reservation. Whenever a service request is made to create a new service flow, SGAC estimates the bandwidth needed for the new flow, and adds it to the counter. The estimated bandwidth is computed as follows:

- For DS service flows, the required bandwidth is the minimum reservation rate, as specified in the DOCSIS service flow QoS parameters.

In each of the above calculations, SGAC does not account for the PHY overhead. DOCSIS overhead is counted only in the UGS and UGS-AD flows. To estimate the fraction of bandwidth available, the calculation must account for the PHY and DOCSIS overhead, and also the overhead incurred to schedule DOCSIS maintenance messages. SGAC applies a correction factor of 80% to the raw data rate to calculate the total available bandwidth.



---

**Note** For the DS and US flow in bonded channels, the maximum reserved bandwidth is the bandwidth defined for the SGAC threshold values. This value is indicated in kbps.

---

## Enabling SGAC Check

A fiber node configured on the CMTS represents one or more matching physical fiber nodes in the HFC plant. The CMTS uses the fiber node configuration to identify the DOCSIS downstream service group (DS-SG) and DOCSIS upstream Service Group (US-SG) of the physical fiber nodes in the plant. The Service Group information is compared with MAC Domain channel configuration to automatically calculate the MAC Domain downstream and upstream service groups (MD-DS-SGs and MD-US-SGs respectively) within the MAC Domains.

Under each Fiber node, use the following procedure to enable SGAC check for an application type and any service flow of the specified application type, which is admitted to a service group.

### Before you begin

Fairness Across DOCSIS Interfaces feature should always be enabled and the bandwidth percentage configured on each bonding group should be kept minimal to allow flexible adjustment of reservable bandwidth.

### Restrictions

SGAC is supported only on the downstream.

## SUMMARY STEPS

1. **enable**
2. **configureterminal**
3. **cable fiber-node *id***
4. **admission-control application-type *n* ds-bandwidth *pct***
5. Ctrl-Z

## DETAILED STEPS

|        | Command or Action                                                                                                                                                                           | Purpose                                                                                                                       |
|--------|---------------------------------------------------------------------------------------------------------------------------------------------------------------------------------------------|-------------------------------------------------------------------------------------------------------------------------------|
| Step 1 | <b>enable</b><br><b>Example:</b><br><pre>Router&gt; enable</pre>                                                                                                                            | Enables privileged EXEC mode. <ul style="list-style-type: none"> <li>• Enter your password if prompted.</li> </ul>            |
| Step 2 | <b>configureterminal</b><br><b>Example:</b><br><pre>Router# configure terminal</pre>                                                                                                        | Enters global configuration mode.                                                                                             |
| Step 3 | <b>cable fiber-node <i>id</i></b><br><b>Example:</b><br><pre>Router(config)# cable fiber-node 1</pre>                                                                                       | Enters cable fiber-node configuration mode to configure a fiber node.                                                         |
| Step 4 | <b>admission-control application-type <i>n</i> ds-bandwidth <i>pct</i></b><br><b>Example:</b><br><pre>Router(config-fiber-node) # admission-control application-type 1 ds-bandwidth 1</pre> | Enables SGAC checking for the specified application-type.<br>Use the <b>no</b> form of this command to disable SGAC checking. |
| Step 5 | <b>Ctrl-Z</b><br><b>Example:</b><br><pre>Router(config-if) # Ctrl^Z</pre>                                                                                                                   | Returns to Privileged EXEC mode.                                                                                              |

**What to do next**

Use the **show cable admission-control fiber-node *n*** command to verify admission-control configuration.

## Configuration Examples for SGAC

This section describes solutions-level examples of the SGAC feature on the Cisco CMTS. This section illustrates the functioning of SGAC in default or non-default operational configurations.

### Example: SGAC Configuration Commands

In this section of configuration examples, the following SGAC parameters are set on the Cisco CMTS:

- All the packetcable flows are mapped into bucket 1.
- The BE service flows are mapped into bucket 8.

The following configuration commands enable these settings:

- To map the packetcable voice flows, use:

```
cable application-type 1 include packetcable normal
```

```
cable application-type 1 include packetcable priority
cable application-type 1 name PktCable
```

- To map the BE flows into bucket 8, use:

```
cable application-type 8 name HSD
cable application-type 8 include best-effort
```

- Given the above configurations, you may also control bandwidth allocation to a PCMM streaming video application. The streaming video application is identified by the PCMM application ID 35. The following commands implement this configuration:

```
cable application-type 2 name PCMM-Vid
cable application-type 2 include pcmm app-id 35
```

- These configurations may be verified on the Cisco CMTS using the following **show** commands:

```
Router# show cable application-type
For bucket 1, Name PktCable
    Packetcable normal priority gates
    Packetcable high priority gates
For bucket 2, Name PCMM-Vid
    PCMM gate app-id = 30
For bucket 3, Name Gaming
    PCMM gate app-id = 40
For bucket 4, Name
For bucket 5, Name
For bucket 6, Name
For bucket 7, Name
For bucket 8, Name HSD
    Best-effort (CIR) flows
```

```
Router# show cable admission-control fiber-node 1
App-type   Name           Exclusive
1          N/A
2          N/A
3          Normal     10%
4          N/A
5          N/A
6          N/A
7          Emergency  N/A
8          N/A
```

```
Router#show cable admission-control interface integrated-Cable 8/0/0:0
```

```
Interface In8/0/0:0
RFID 24576
```

```
Resource - Downstream Bandwidth
```

```
-----
App-type   Name           Reservation/bps   Exclusive   Rejected
1          N/A            0                N/A         0
2          N/A            0                N/A         0
3          Normal       0                10%         0
4          N/A            0                N/A         0
5          N/A            0                N/A         0
6          N/A            0                N/A         0
7          Emergency    0                N/A         0
8          N/A            0                N/A         0
Max Reserved BW = 300000 bps
Total Current Reservation = 0 bps
```

```

Guaranteed Bonus BW = 21055000 bps
Non-guaranteed Bonus BW = 7744000 bps
Superset BGs: Wi8/0/0:0 Wi8/0/0:4 Wi8/0/0:6

```

```
Router#show cable admission-control interface wideband-Cable 8/0/0:0
```

```

Interface Wi8/0/0:0
BGID: 24577

```

```
Resource - Downstream Bandwidth
```

```

-----
App-type   Name           Reservation/bps  Exclusive   Rejected
1          0               0              N/A         0
2          0               0              N/A         0
3          Normal         0              10%         0
4          0               0              N/A         0
5          0               0              N/A         0
6          0               0              N/A         0
7          Emergency      0              N/A         0
8          0               0              N/A         0

```

```

Max Reserved BW = 600000 bps
Total Current Reservation = 0 bps
Guaranteed Bonus BW = 21055000 bps
Non-guaranteed Bonus BW = 36844000 bps
Subset BGs: In8/0/0:0 In8/0/0:1
Superset BGs: Wi8/0/0:4 Wi8/0/0:6
Overlapping BGs: N/A

```

These above configuration examples might be omitted or changed, but the remaining examples in this section presume the above configurations.

## Example: SGAC for Downstream Traffic

This example presumes that you have configured the rules according to the commands illustrated at the start of this section.

- All the voice flows in bucket 1.
- All the CIR data flows are categorized in bucket 8.

The below example illustrates a sample configuration for SGAC with downstream traffic. In this example, if voice traffic exceeds 30% bandwidth consumption, additional voice flows are denied.

- 30% downstream throughput is reserved exclusively for voice traffic.

The following command implements this configuration:

```
Router(config-fiber-node)#admission-control application-type 1 ds-bandwidth 30
```

The below example illustrates how flexible bandwidth allocation is configured. In this example, normal voice traffic (application-type 1) is associated with two thresholds. Normal voice traffic alone can use up to 40% of the service group's capacity, while normal and emergency voice traffic combined can use up to 50% of the service group's capacity. This means that emergency voice traffic can have at least 10% of the service group's capacity, even if normal voice traffic has used up its share of 40%:

```
Router(config-fiber-node)#admission-control application-type 1 ds-bandwidth 40
Router(config-fiber-node)#admission-control application-type 1-2 ds-bandwidth 50
```

where,

- 1 is normal voice application type
- 2 is emergency voice application type

## Additional References

The following topics provide references related to SGAC for the Cisco CMTS.

### Related Documents

| Related Topic             | Document Title                                     |
|---------------------------|----------------------------------------------------|
| Cisco CMTS Cable Commands | <a href="#">Cisco CMTS Cable Command Reference</a> |

### Standards

| Standard                                         | Title                                                                                                                                                 |
|--------------------------------------------------|-------------------------------------------------------------------------------------------------------------------------------------------------------|
| CableLabs™ DOCSIS 1.1 specifications             | <a href="http://www.cablelabs.com/cablemodem/">http://www.cablelabs.com/cablemodem/</a>                                                               |
| CableLabs™ PacketCable specifications            | <a href="http://www.cablelabs.com/packetcable/">http://www.cablelabs.com/packetcable/</a>                                                             |
| CableLabs™ PacketCable MultiMedia specifications | <a href="http://www.cablelabs.com/packetcable/specifications/multimedia.html">http://www.cablelabs.com/packetcable/specifications/multimedia.html</a> |

### MIBs

| MIB  | MIBs Link                                                                                                                                                                        |
|------|----------------------------------------------------------------------------------------------------------------------------------------------------------------------------------|
| MIBs | To locate and download MIBs for selected platforms, use Cisco MIB Locator found at the following URL:<br><a href="http://www.cisco.com/go/mibs">http://www.cisco.com/go/mibs</a> |

**Technical Assistance**

| Description                                                                                                                                                                                                                                                                                                                                                                                                                                                                                                                                                             | Link                                                                                                              |
|-------------------------------------------------------------------------------------------------------------------------------------------------------------------------------------------------------------------------------------------------------------------------------------------------------------------------------------------------------------------------------------------------------------------------------------------------------------------------------------------------------------------------------------------------------------------------|-------------------------------------------------------------------------------------------------------------------|
| <p>The Cisco Support website provides extensive online resources, including documentation and tools for troubleshooting and resolving technical issues with Cisco products and technologies.</p> <p>To receive security and technical information about your products, you can subscribe to various services, such as the Product Alert Tool (accessed from Field Notices), the Cisco Technical Services Newsletter, and Really Simple Syndication (RSS) Feeds.</p> <p>Access to most tools on the Cisco Support website requires a Cisco.com user ID and password.</p> | <a href="http://www.cisco.com/cisco/web/support/index.html">http://www.cisco.com/cisco/web/support/index.html</a> |

## Feature Information for Service Group Admission Control

Use Cisco Feature Navigator to find information about the platform support and software image support. Cisco Feature Navigator enables you to determine which software images support a specific software release, feature set, or platform. To access Cisco Feature Navigator, go to the <https://cfnng.cisco.com/> link. An account on the Cisco.com page is not required.



**Note** The following table lists the software release in which a given feature is introduced. Unless noted otherwise, subsequent releases of that software release train also support that feature.

**Table 302: Feature Information for Service Group Admission Control**

| Feature Name                    | Releases                    | Feature Information                                                                                           |
|---------------------------------|-----------------------------|---------------------------------------------------------------------------------------------------------------|
| Service group admission control | Cisco IOS XE Everest 16.6.1 | This feature was integrated into Cisco IOS XE Everest 16.6.1 on Cisco cBR Series Converged Broadband Routers. |



## CHAPTER 95

# Subscriber Traffic Management

This document describes the Subscriber Traffic Management (STM) feature Version 1.3. STM feature supports all DOCSIS-compliant cable modems.

The STM feature allows a service provider to configure a maximum bandwidth threshold over a fixed period for a specific service class (or quality of service [QoS] profile). The subscribers who exceed this configured threshold can then be identified and allocated reduced QoS. STM works as a low-CPU alternative to Network-Based Application Recognition (NBAR) and access control lists (ACLs). However, using STM does not mean that NBAR and ACLs have to be turned off; STM can be applied along with NBAR and ACLs. STM also works in conjunction with the Cisco Broadband Troubleshooter to support additional network management and troubleshooting functions in the Cisco CMTS.



---

**Important** In this document, the phrase QoS profile is synonymously used to indicate a service class for a DOCSIS 1.1 cable modem. However, QoS profile applies only to DOCSIS 1.0 operations. In instances where QoS profile is mentioned to indicate DOCSIS 1.1 operations, the QoS profile should be treated as a service class.

---

Your software release may not support all the features that are documented in this module. For the latest feature information and caveats, see the release notes for your platform and software release. The Feature Information Table at the end of this document provides information about the documented features and lists the releases in which each feature is supported.

Use Cisco Feature Navigator to find information about platform support and Cisco software image support. To access Cisco Feature Navigator, go to <http://tools.cisco.com/ITDIT/CFN/>. An account on <http://www.cisco.com/> is not required.

- [Hardware Compatibility Matrix for the Cisco cBR Series Routers, on page 1508](#)
- [Restrictions for Subscriber Traffic Management on the Cisco CMTS Routers, on page 1509](#)
- [Information About Subscriber Traffic Management on the Cisco CMTS Routers, on page 1510](#)
- [How to Configure the Subscriber Traffic Management Feature on the Cisco CMTS Routers, on page 1515](#)
- [Monitoring the Subscriber Traffic Management Feature on the Cisco CMTS Routers, on page 1525](#)
- [Configuration Examples for Subscriber Traffic Management on the Cisco CMTS Routers, on page 1528](#)
- [Additional References, on page 1531](#)
- [Feature Information for Subscriber Traffic Management, on page 1533](#)

# Hardware Compatibility Matrix for the Cisco cBR Series Routers



**Note** The hardware components that are introduced in a given Cisco IOS-XE Release are supported in all subsequent releases unless otherwise specified.

**Table 303: Hardware Compatibility Matrix for the Cisco cBR Series Routers**

| Cisco CMTS Platform                    | Processor Engine                                                                                                                                                                                  | Interface Cards                                                                                                                                                                                                                                                                                                                                                                                                                                                                                                                                                                                                                                                                                                                                                                                 |
|----------------------------------------|---------------------------------------------------------------------------------------------------------------------------------------------------------------------------------------------------|-------------------------------------------------------------------------------------------------------------------------------------------------------------------------------------------------------------------------------------------------------------------------------------------------------------------------------------------------------------------------------------------------------------------------------------------------------------------------------------------------------------------------------------------------------------------------------------------------------------------------------------------------------------------------------------------------------------------------------------------------------------------------------------------------|
| Cisco cBR-8 Converged Broadband Router | <p><b>Cisco IOS-XE Release 16.5.1 and Later Releases</b></p> <p>Cisco cBR-8 Supervisor:</p> <ul style="list-style-type: none"> <li>• PID—CBR-SUP-250G</li> <li>• PID—CBR-CCAP-SUP-160G</li> </ul> | <p><b>Cisco IOS-XE Release 16.5.1 and Later Releases</b></p> <p>Cisco cBR-8 CCAP Line Cards:</p> <ul style="list-style-type: none"> <li>• PID—CBR-LC-8D30-16U30</li> <li>• PID—CBR-LC-8D31-16U30</li> <li>• PID—CBR-RF-PIC</li> <li>• PID—CBR-RF-PROT-PIC</li> <li>• PID—CBR-CCAP-LC-40G</li> <li>• PID—CBR-CCAP-LC-40G-R</li> <li>• PID—CBR-CCAP-LC-G2-R</li> <li>• PID—CBR-SUP-8X10G-PIC</li> <li>• PID—CBR-2X100G-PIC</li> </ul> <p>Digital PICs:</p> <ul style="list-style-type: none"> <li>• PID—CBR-DPIC-8X10G</li> <li>• PID—CBR-DPIC-2X100G</li> </ul> <p>Cisco cBR-8 Downstream PHY Module:</p> <ul style="list-style-type: none"> <li>• PID—CBR-D31-DS-MOD</li> </ul> <p>Cisco cBR-8 Upstream PHY Modules:</p> <ul style="list-style-type: none"> <li>• PID—CBR-D31-US-MOD</li> </ul> |





---

**Note** Do not use DPICs (8X10G and 2x100G) to forward IP traffic, as it may cause buffer exhaustion, leading to line card reload.

The only allowed traffic on a DPIC interface is DEPI, UEPI, and GCP traffic from the Cisco cBR-8 router to Remote PHY devices. Other traffic such as DHCP, SSH, and UTSC should flow via another router, since DPICs cannot be used for normal routing.

---

## Restrictions for Subscriber Traffic Management on the Cisco CMTS Routers



---

**Note** In this document, the phrase QoS profile is synonymously used to indicate a service class for a DOCSIS 1.1 cable modem. However, QoS profile applies only to DOCSIS 1.0 operations. In instances where QoS profile is mentioned to indicate DOCSIS 1.1 operations, the QoS profile should be treated as a service class.

---

The STM feature has the following restrictions and limitations:

- In STM version 1.1, the sampling rate range (duration) is calculated using the monitoring duration rather than the constant range (10 to 30 minutes) used in STM 1.0.
  - If the monitoring duration is more than a day (1440 minutes), the duration sample rate is calculated as (duration / 100).
  - If the monitoring duration is less than a day, the sample rate range is from 10 to 30 minutes.
  - If you are using STM 1.0 with a duration of two days and a sample rate of 20 minutes, and you try to restore that configuration in STM 1.1, the command fails because now the valid range is from 28 to 86 minutes.
- For DOCSIS1.0, the registered QoS profile specified by an enforce-rule must match exactly a QoS profile that exists on the Cisco CMTS. To manage a cable modem that is using a modem-created QoS profile, you must first create that same exact QoS profile on the Cisco CMTS. All parameters in the QoS profile must match before the cable modem can be managed by the enforce-rule.
- The Cisco cBR series routers support a certain maximum of 40 enforce-rules. If you have created the maximum number of enforce-rules and want to create another rule, you must first delete one of the existing rules.
- Changing the configuration of an enforce-rule automatically resets all byte counters for the subscribers who are mapped to that enforce-rule.
- When specifying a QoS profile to be enforced when users violate their registered QoS profiles, both the originally provisioned QoS profile and the enforced QoS profile must be created on the Cisco CMTS.
- The Subscriber Traffic Management feature calculates duration based on the time set on the router, not uptime. Therefore, if you use the **clock set** command to change the time on the router, you might affect the STM monitoring behavior.

- The maximum cycle for subscriber traffic management is 31 days. If you choose a cycle of 31 days, the minimum sample rate that you can set is (31 days/100) minutes.

# Information About Subscriber Traffic Management on the Cisco CMTS Routers

This section contains the following:

## Feature Overview

The STM feature allows service providers to configure a maximum bandwidth threshold over a fixed period, for a specific service class (or QoS profile). The subscribers who exceed this configured threshold can then be identified and allocated a reduced QoS. This feature supplements current techniques such as NBAR and ACLs, to ensure that a minority of users do not consume a majority of a cable network's bandwidth.

Current subscriber controls, such as NBAR and ACLs, examine all packets coming into the CMTS. These techniques can curb a large volume of problem traffic, but they are not as effective in dealing with the latest generation of peer-to-peer file-sharing applications that can place heavy demands on a network's available bandwidth.

The STM feature allows service providers to focus on a minority of potential problem users without impacting network performance or other users who are abiding by their service agreements.

The STM feature supports two types of monitoring:

- Legacy Monitoring—Legacy monitoring allows you to set up a single monitoring duration without the ability to choose the time of day when that monitoring is performed. The configured monitoring parameters remain constant throughout the day.
- Peak-Offpeak Monitoring—Peak-Offpeak monitoring allows you to specify up to two high-traffic periods in a day for monitoring, in addition to the ability to continue monitoring during the remaining (or off-peak) periods. By combining the peak time option with weekend monitoring, you can identify and limit the bandwidth usage of certain subscribers for up to two peak network usage periods during weekdays, and during a different set of peak usage periods on weekends.

When a cable modem goes offline and remains offline for 24 hours, the Cisco CMTS router deletes its service flow IDs from its internal databases, and also deletes the modem's traffic counters. This can allow some users to exceed their bandwidth limits, go offline, and come back online with new counters. The Subscriber Traffic Management feature helps to thwart these types of theft-of-service attacks by implementing a penalty period for cable modems that violate their service level agreements (SLAs). Even if a cable modem goes offline, its counters are still reset, and the CMTS continues to enforce the penalty period.

## Feature List

The Subscriber Traffic Management feature has the following operational features:

- Subscriber Traffic Management 1.1 (STM 1.1) supports cable modems that have registered for DOCSIS 1.1 operations (using the service class/service flow ID [SFID] model).
- Up to 40 enforce-rules can be created on each router.

- Separate enforce-rules can be used for downstream traffic and for upstream traffic. However, the limit on the total number of enforce-rules that can be configured includes the upstream and downstream rules combined.
- Each enforce-rule uses a subscriber's registered QoS profile to identify which users should be monitored for excessive traffic for DOCSIS1.0 cable modems. The registered QoS profile must exist on the Cisco CMTS. If you want to manage cable modems that are using QoS profiles that were created by the cable modem, you must first manually create a QoS profile with the exact same QoS parameters on the Cisco CMTS, and then allow the cable modem to come online using the manually created profile.
- Each enforce-rule specifies the maximum number of kilobytes a user can transmit during a specified window.
- Subscribers who exceed the maximum bandwidth that is specified by their enforce-rule can be automatically switched to a separate enforced QoS profile that limits their network use for a customizable penalty period. The enforced QoS profile can change the guaranteed bandwidth, priority, or any other aspect of the traffic that the service provider considers an acceptable response to subscribers who violate their service agreements.
- Subscribers are automatically switched back to their registered QoS profile at the end of their penalty period. A technician at the service provider's network operations center (NOC) can also switch them back before the penalty period expires.



---

**Note** To manually switch back, delete the cable modem and allow it to register again.

---

- This feature also supports a **no-persistence** option, so that the enforced QoS profile does not remain in effect when a cable modem reboots. This option is particularly useful when the feature is initially implemented, so that the service providers can identify problem subscribers and applications, without creating a major impact on the entire user base. When repeat offenders are found, they can then be switched to an enforce-rule that does keep the enforced QoS profile in effect even when the cable modem reboots.
- Service providers can display a list of all subscribers' current usage statistics. Service providers can also display a list of just those subscribers who are overconsuming bandwidth.
- The penalty period persists across reboots of the cable modem, so subscribers cannot avoid the enforced QoS profile by resetting their modems and reregistering on the cable network. This allows service providers to set an appropriate penalty for those users that consistently exceed the maximum bandwidth they have been allocated. Service providers also can specify a time of day when CMs that are identified for penalty can be released from the penalty period.
- If a user that is using excessive bandwidth decides to upgrade to a higher level of service, the service provider can reconfigure the provisioning system to assign a new QoS profile to the cable modem. The user can then reboot the cable modem and come online using the new level of service.
- Service providers can change subscriber service classes for a particular modem using the **cable modem service-class-name** command.
- Different subscriber monitoring parameters can be configured for weekends, including peak and offpeak monitoring windows. You can also establish the same monitoring windows for every day of the week, or turn off monitoring altogether on the weekends as desired.

## Sliding Window for Monitoring Service Flows

When an enforce-rule is activated, the CMTS periodically checks the bandwidth being used by subscribers to determine whether any subscribers are consuming more bandwidth than that specified by their registered

QoS profiles. The CMTS keeps track of the subscribers using a sliding window that begins at each sample-rate interval and continues for the monitoring-duration period.

Each sample-rate interval begins a new sliding window period for which the CMTS keeps track of the total bytes transmitted. At the end of each sliding window period, the CMTS examines the byte counters to determine if any subscriber is currently overconsuming bandwidth on the network.

For example, with the default sample-rate interval of 15 minutes and the default monitoring-duration window of 360 minutes (6 hours), the CMTS samples the bandwidth usage every 15 minutes and determines the total bytes transmitted at the end of each 360-minute window. Therefore, every 15 minutes, the CMTS determines each subscriber's usage statistics for the preceding 6-hour period.

Figure below illustrates how this process works, with a new sliding window beginning at the beginning of each sample-rate interval period.

**Figure 38: Monitoring-Duration Windows**

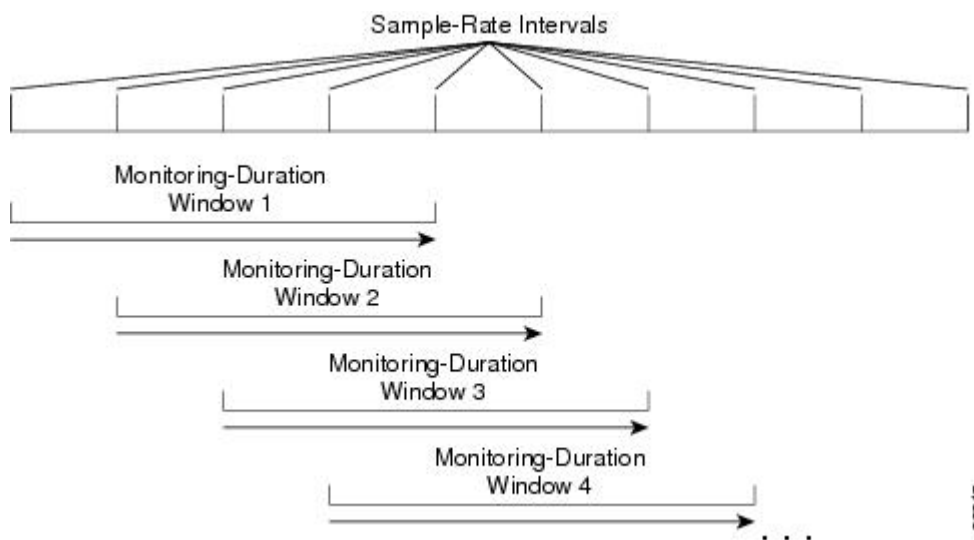

## Weekend Monitoring

With standard legacy and peak-offpeak monitoring configuration, monitoring continues to occur on the weekends.

STM version 1.2 supports configuration of different monitoring conditions on weekends. Weekend monitoring options support the same parameters that are available in the existing monitoring options, but use a separate set of commands to configure alternate monitoring on weekend days. This includes configuration of peak and offpeak weekend monitoring windows.

In addition, the CLI supports the ability to turn off any monitoring on the weekend, or to use the same monitoring conditions for every day of the week.

## SNMP Trap Notifications

Simple Network Management Protocol (SNMP) trap notification can be sent whenever a subscriber violates the enforce-rule. This trap is defined in the CISCO-CABLE-QOS-MONITOR-MIB and is enabled using the **snmp-server enable traps cable** command.

Each SNMP trap notification contains the following information:

- MAC address of the subscriber's cable modem
- Name of the enforce-rule being applied to this subscriber
- Total bytes sent by the subscriber during the monitoring-duration window
- Time at which the subscriber's penalty period expires

The CISCO-CABLE-QOS-MONITOR-MIB also contains the following tables that provide information about the Subscriber Traffic Management configuration and about subscribers who violate their enforce-rules:

- `ccqmCmtsEnforceRuleTable`—Contains the attributes of the enforce-rules that are currently configured on the Cisco CMTS.
- `ccqmEnfRuleViolateTable`—Provides a snapshot list of the subscribers who violated their enforce-rules over the sliding monitoring-duration window.

The following objects are used for enforce rules:

- `ccqmCmtsEnfRulePenaltyEndTime`
- `ccqmCmtsEnfRuleWkndOff`
- `ccqmCmtsEnfRuleWkndMonDuration`
- `ccqmCmtsEnfRuleWkndAvgRate`
- `ccqmCmtsEnfRuleWkndSampleRate`
- `ccqmCmtsEnfRuleWkndFirstPeakTime`
- `ccqmCmtsEnfRuleWkndFirstDuration`
- `ccqmCmtsEnfRuleWkndFirstAvgRate`
- `ccqmCmtsEnfRuleWkndSecondPeakTime`
- `ccqmCmtsEnfRuleWkndSecondDuration`
- `ccqmCmtsEnfRuleWkndSecondAvgRate`
- `ccqmCmtsEnfRuleWkndOffPeakDuration`
- `ccqmCmtsEnfRuleWkndOffPeakAvgRate`
- `ccqmCmtsEnfRuleWkndAutoEnforce`
- `ccqmCmtsEnfRuleFirstPeakTimeMin`
- `ccqmCmtsEnfRuleSecondPeakTimeMin`
- `ccqmCmtsEnfRuleWkndFirstPeakTimeMin`
- `ccqmCmtsEnfRuleWkndSecondPeakTimeMin`
- `ccqmCmtsEnfRulePenaltyEndTimeMin`
- `ccqmCmtsEnfRuleWkPenaltyPeriod`
- `ccqmCmtsEnfRuleWkndPenaltyPeriod`
- `ccqmCmtsEnfRuleRelTimeMonitorOn`

The following objects are used for enforce rule violations:

- `ccqmEnfRuleViolateID`
- `ccqmEnfRuleViolateMacAddr`
- `ccqmEnfRuleViolateRuleName`
- `ccqmEnfRuleViolateByteCount`
- `ccqmEnfRuleViolateLastDetectTime`
- `ccqmEnfRuleViolatePenaltyExpTime`

- ccqmEnfRuleViolateAvgRate

## Cable Modem Interaction with the Subscriber Traffic Management Feature

The Subscriber Traffic Management feature ensures that users cannot bypass the QoS restrictions by rebooting their cable modems or performing other configuration changes. The service provider, however, continues to be able to change the modems' profiles and other configuration parameters as desired.

When the Subscriber Traffic Management feature is enabled, the following behavior is in effect:

- The primary service flow counters for downstream and upstream traffic are preserved when the cable modem reboots. The service provider, however, can reset the counters by changing the QoS profile for the cable modem using the **cable modem qos profile** command and resetting the cable modem.
- Secondary service flow counters are reset whenever the cable modem reboots. This happens regardless of the enforce-rule configuration.
- The cable modem retains its current primary downstream and upstream service flows when it reboots. If the cable modem is in an enforced QoS profile penalty period when it reboots, it continues using the enforced QoS profile after the reboot. Service providers can manually change the profile by assigning a new QoS profile using the **cable modem qos profile** command.



---

**Note** Changing the QoS profile for a cable modem using the **cable modem qos profile** command, also changes the enforce-rule for the cable modem when it reboots. When the cable modem comes back online, it begins operating under the enforce-rule whose registered QoS profile (see the **qos-profile registered** command) matches the new QoS profile the modem is using.

---

- Service providers can also change the enforce-rule configuration. The following happens when the provider changes the enforce-rule configuration:
  - If the enforce-rule is disabled (using the **no enabled** command), all cable modems using that rule's registered QoS profile are no longer managed by the Subscriber Traffic Management feature. Configuring no enabled, deactivates the enforce-rule and moves all the modems in penalty to its registered QoS.
  - If the registered QoS profile for the rule is changed (using the **qos-profile registered** command), the cable modems that are using the previous registered QoS profile are no longer managed by the Subscriber Traffic Management feature. Instead, any cable modems that use the new registered QoS profile begin being managed by this rule.
  - If the enforced QoS profile for the rule is changed (using the **qos-profile enforced** command), any cable modems using this rule that are currently in the penalty period continue using the previously configured enforced QoS profile. Any cable modems that enter the penalty period after this configuration change, however, use the new enforced QoS profile.
- Service providers also have the option of making an enforce-rule nonpersistent, so that the enforced QoS profile does not remain in force when a cable modem reboots. Instead, when the cable modem reboots and reregisters with the Cisco CMTS, the CMTS assigns it the QoS profile that is specified in its DOCSIS configuration file.

# How to Configure the Subscriber Traffic Management Feature on the Cisco CMTS Routers

This section contains the following:

## Creating and Configuring an Enforce-Rule

Every service class name that needs to be monitored will be linked with an enforce-rule. An enforce-rule defines the monitoring duration, the sample rate, the penalty period, and the registered service class name that the enforce-rule is linked to and the enforced service class name.

Use the procedure given below to create and configure an enforce-rule. An enforce-rule does not become active until the **enabled** command is given.

### Before you begin

- The registered and enforced service (QoS) profiles must be created on the CMTS before creating an enforce-rule that uses those profiles. If you want to manage a cable modem that currently uses a modem-created QoS profile, you must first manually create a new QoS profile on the CMTS with the same QoS parameters as the modem-created profile. Then allow the modem to come online using the manually created profile before beginning this procedure.
  - To display quality of service (QoS) profiles for a Cisco CMTS, use the `show cable qos profile` command in privileged EXEC mode.
  - To configure a QoS profile, use the `cable qos profile` command in global configuration mode. To set a particular value to its default, or to delete the profile when no specific parameters have been set, use the `no` form of this command.
- For monitoring of DOCSIS 1.1 cable modems:
  - Only DOCSIS 1.1 modems that register with a service class name are monitored.
  - To ensure that the DOCSIS 1.1 service flow counters remain across a reboot of the CM, configure the `cable primary-sflow-qos11 keep all` global configuration command.
- Only primary upstream and downstream service flows are supported.



### Restriction

- When configuring peak-offpeak monitoring, you can define a maximum of two peak durations within a day, and also monitoring of the remaining hours, if you configure the offpeak duration. The monitoring duration and threshold for first peak, second peak, and offpeak, can be different. However, the monitoring duration for any peak or offpeak configuration cannot be more than a day.
- The parameters defined by the named service class should always be a compatible subset of the registered set of parameters for the CM. Only certain options can be changed using a CMTS router service class, such as the **max-rate**, **priority**, or **tos-overwrite** options. The **max-burst** option in both the enforced and registered CMTS router service classes must strictly match the value for **max-burst** in the registered DOCSIS configuration file. If the service class value does not match, either the cable modem registration will fail with a reject-c state, or the enforced class will fail.

## Procedure

|               | Command or Action                                                                                                                                                                                                                                                                                                                                                                                                                                                                                                                                                                                                                                 | Purpose                                                                                                                                                                                                                                                                                                                                                                                                                                                                                                                                                                                                                                                                                                                                                                                                                                                                                                                                 |
|---------------|---------------------------------------------------------------------------------------------------------------------------------------------------------------------------------------------------------------------------------------------------------------------------------------------------------------------------------------------------------------------------------------------------------------------------------------------------------------------------------------------------------------------------------------------------------------------------------------------------------------------------------------------------|-----------------------------------------------------------------------------------------------------------------------------------------------------------------------------------------------------------------------------------------------------------------------------------------------------------------------------------------------------------------------------------------------------------------------------------------------------------------------------------------------------------------------------------------------------------------------------------------------------------------------------------------------------------------------------------------------------------------------------------------------------------------------------------------------------------------------------------------------------------------------------------------------------------------------------------------|
| <b>Step 1</b> | <b>enable</b><br><b>Example:</b><br>Router> <b>enable</b>                                                                                                                                                                                                                                                                                                                                                                                                                                                                                                                                                                                         | Enables privileged EXEC mode. Enter your password if prompted.                                                                                                                                                                                                                                                                                                                                                                                                                                                                                                                                                                                                                                                                                                                                                                                                                                                                          |
| <b>Step 2</b> | <b>configure terminal</b><br><b>Example:</b><br>Router# <b>configure terminal</b>                                                                                                                                                                                                                                                                                                                                                                                                                                                                                                                                                                 | Enters the global configuration mode.                                                                                                                                                                                                                                                                                                                                                                                                                                                                                                                                                                                                                                                                                                                                                                                                                                                                                                   |
| <b>Step 3</b> | <b>cable qos enforce-rule <i>name</i></b><br><b>Example:</b><br>Router(config)# <b>cable qos enforce-rule test</b>                                                                                                                                                                                                                                                                                                                                                                                                                                                                                                                                | Creates an enforce-rule with the specified <i>name</i> and enters the enforce-rule configuration mode.<br><br><b>Note</b> Each enforce-rule can be created by giving it a name.                                                                                                                                                                                                                                                                                                                                                                                                                                                                                                                                                                                                                                                                                                                                                         |
| <b>Step 4</b> | <b>monitoring-basics {legacy   peak-offpeak} {docsis10   docsis11}</b><br><b>Example:</b><br>Router(enforce-rule)# <b>monitoring-basics peak-offpeak docsis11</b>                                                                                                                                                                                                                                                                                                                                                                                                                                                                                 | Defines the kind of monitoring desired and the type of modems to be monitored.<br><br>The default is legacy and DOCSIS 1.0.                                                                                                                                                                                                                                                                                                                                                                                                                                                                                                                                                                                                                                                                                                                                                                                                             |
| <b>Step 5</b> | Perform one of the following: <ul style="list-style-type: none"> <li>• If you specified DOCSIS 1.0 cable modems in <a href="#">Step 4, on page 1516</a>, use the following commands:               <ol style="list-style-type: none"> <li>a. <b>qos-profile registered <i>profile-id</i></b></li> <li>b. <b>qos-profile enforced <i>profile-id</i> [no-persistence]</b></li> </ol> </li> <li>• If you specified DOCSIS 1.1 cable modems in <a href="#">Step 4, on page 1516</a>, use the <b>service-class {enforced   registered} <i>name</i></b> command.</li> </ul> <b>Example:</b><br>Router(enforce-rule)# <b>service-class enforced test</b> | <ul style="list-style-type: none"> <li>• For DOCSIS 1.0 cable modems:               <ol style="list-style-type: none"> <li>a. Specifies the registered quality of service (QoS) profile that should be used for this enforce-rule.<br/><br/> <b>Note</b> If you want to manage a cable modem that currently uses a modem-created QoS profile, you must first manually create a new QoS profile on the CMTS with the same QoS parameters as the modem-created profile. Then allow the modem to come online using the manually created profile before using this command.</li> <li>b. Specifies the quality of service (QoS) profile that should be enforced when users violate their registered QoS profiles for DOCSIS 1.0 cable modems.</li> </ol> </li> <li>• For DOCSIS 1.1 (and later) cable modems, identifies a particular service class with the specified <i>name</i> for cable modem monitoring in an enforce-rule.</li> </ul> |



|         | Command or Action                                                                                                                                                                                                                                                                                                                                                                                                                                                                                                                                                                                                                                                                                                                                                                                                                   | Purpose                                                                                                                                          |
|---------|-------------------------------------------------------------------------------------------------------------------------------------------------------------------------------------------------------------------------------------------------------------------------------------------------------------------------------------------------------------------------------------------------------------------------------------------------------------------------------------------------------------------------------------------------------------------------------------------------------------------------------------------------------------------------------------------------------------------------------------------------------------------------------------------------------------------------------------|--------------------------------------------------------------------------------------------------------------------------------------------------|
| Step 6  | <p><b>duration</b> <i>minutes</i> <b>avg-rate</b> <i>rate</i> <b>sample-interval</b> <i>minutes</i> [<b>penalty</b> <i>minutes</i>] {<b>downstream</b>   <b>upstream</b>} [<b>enforce</b>]</p> <p><b>Example:</b></p> <pre>Router(enforce-rule)# duration 120 avg-rate 500 sample-interval 15 penalty 120 downstream enforce</pre>                                                                                                                                                                                                                                                                                                                                                                                                                                                                                                  | Specifies the time period and sample rate used for monitoring subscribers when legacy monitoring is configured (Step 4, on page 1516).           |
| Step 7  | <p><b>peak-time1</b> {<i>hour</i>   <i>hour:minutes</i>} <b>duration</b> <i>minutes</i> <b>avg-rate</b> <i>rate</i> [<b>peak-time2</b> {<i>hour</i>   <i>hour:minutes</i>} <b>duration</b> <i>minutes</i> <b>avg-rate</b> <i>rate</i>] [<b>duration</b> <i>offpeak-minutes</i> <b>avg-rate</b> <i>offpeak-rate</i> ] <b>sample-interval</b> <i>minutes</i> [<b>penalty</b> <i>minutes</i>] {<b>downstream</b>   <b>upstream</b>} [<b>enforce</b>]</p> <p><b>Example:</b></p> <pre>Router(enforce-rule)# peak-time1 6 duration 120 avg-rate 2 peak-time2 18 duration 120 avg-rate 2 duration 120 avg-rate 3 sample-interval 15 upstream enforce Router(enforce-rule)# peak-time1 6:30 duration 120 avg-rate 2 peak-time2 18:40 duration 120 avg-rate 2 duration 120 avg-rate 3 sample-interval 15 penalty 120 upstream enforce</pre> | Specifies peak monitoring periods when peak-offpeak monitoring is configured (Step 4, on page 1516).                                             |
| Step 8  | <p><b>penalty-period</b> <i>minutes</i> [<b>time-of-day</b> {<i>hour</i> <i>hour:minutes</i>}] [<b>monitoring-on</b>]</p> <p><b>Example:</b></p> <pre>Router(enforce-rule)# penalty-period 120</pre>                                                                                                                                                                                                                                                                                                                                                                                                                                                                                                                                                                                                                                | (Optional) Specifies the period for which an enforced QoS profile should be in effect for subscribers who violate their registered QoS profiles. |
| Step 9  | <p><b>enabled</b></p> <p><b>Example:</b></p> <pre>Router(enforce-rule)# enabled</pre>                                                                                                                                                                                                                                                                                                                                                                                                                                                                                                                                                                                                                                                                                                                                               | (Optional) Activates the enforce-rule and begins subscriber traffic management.                                                                  |
| Step 10 | <p><b>end</b></p> <p><b>Example:</b></p> <pre>Router(enforce-rule)# end</pre>                                                                                                                                                                                                                                                                                                                                                                                                                                                                                                                                                                                                                                                                                                                                                       | Exits enforce-rule configuration mode and returns to privileged EXEC mode.                                                                       |

## Examples

This section provides command-line interface (CLI) examples, including the help feature for some of the enforce-rule commands.

### Example: Legacy Monitoring Configuration

The following example shows a sample configuration of an enforce-rule for legacy monitoring:

## Example: Peak-offpeak Monitoring Configuration

```

Router(config)# cable qos enforce-rule test
Router(enforce-rule)# monitoring-basics ?
  legacy          Enable legacy (same average rate for all day)  monitoring
  peak-offpeak    Enable peak-offpeak monitoring
Router(enforce-rule)# monitoring-basics legacy ?
  docsis10        Enforce-rule will map to docsis 1.0 modems
  docsis11        Enforce-rule will map to docsis 1.1 modems
Router(enforce-rule)# monitoring-basics legacy docsis11
Router(enforce-rule)# service-class ?
  enforced        Enforced service class
  registered       Registered service class
Router(enforce-rule)# service-class registered ?
  WORD            Registered service class name
Router(enforce-rule)# service-class registered BEUS
Router(enforce-rule)# service-class enforced test
Router(enforce-rule)# duration ?
  <10-10080>      Duration in minutes
Router(enforce-rule)# duration 120 ?
  avg-rate        Average rate for the duration in kbits/sec
Router(enforce-rule)# duration 120 avg-rate ?
  <1-4294967>     average rate in kbits/sec
Router(enforce-rule)# duration 120 avg-rate 2 ?
  sample-interval Rate of sampling in Minutes
Router(enforce-rule)# duration 120 avg-rate 2 sample-interval ?
  <1-30>          Sampling rate in Minutes
Router(enforce-rule)# duration 120 avg-rate 2 sample-interval 15 ?
  downstream      downstream
  upstream         upstream
Router(enforce-rule)# duration 120 avg-rate 2 sample-interval 15 upstream ?
  enforce          enforce the qos-profile automatically
  <cr>
Router(enforce-rule)# duration 120 avg-rate 2 sample-interval 15 upstream enf
Router(enforce-rule)# $ avg-rate 2 sample-interval 15 upstream enforce
Router(enforce-rule)# enabled
Router(enforce-rule)# end

```

## Example: Peak-offpeak Monitoring Configuration

The following example shows a sample configuration of an enforce-rule for peak-offpeak monitoring:

```

Router(config)# cable qos enforce-rule test
Router(enforce-rule)# monitoring-basics peak-offpeak
Router(enforce-rule)# monitoring-basics peak-offpeak docsis10
Router(enforce-rule)# qos-profile ?
  enforced        Enforced qos profile
  registered       QoS profile index
Router(enforce-rule)# qos-profile registered ?
  <1-255>         Registered QoS profile index
Router(enforce-rule)# qos-profile registered 5
Router(enforce-rule)# qos-profile enforced 4
Router(enforce-rule)# peak-time1 6 ?
  duration        First peak duration
Router(enforce-rule)# peak-time1 6 duration ?
  <60-1440>       Duration in minutes
Router(enforce-rule)# peak-time1 6 duration 120 ?
  avg-rate        First peak average rate in kbits/sec
Router(enforce-rule)# peak-time1 6 duration 120 avg-rate ?
  <1-4294967>     Average rate in kbits/sec
Router(enforce-rule)# peak-time1 6 duration 120 avg-rate 2 ?
  duration        Off-peak duration

```

```

peak-time2      Second peak time
sample-interval Rate of sampling in minutes

Router(enforce-rule)# peak-time1 6 duration 120 avg-rate 2 peak-time2 ?
<10-1440> Start of second peak time
Router(enforce-rule)# peak-time1 6 duration 120 avg-rate 2 peak-time2 18 ?
duration      Second peak duration
Router(enforce-rule)# $6 duration 120 avg-rate 2 peak-time2 18 duration ?
<10-1440> Duration in minutes
Router(enforce-rule)# $6 duration 120 avg-rate 2 peak-time2 18 duration 120 ?
avg-rate      Second peak average rate in kbits/sec
Router(enforce-rule)# $ 180 avg-rate 2 peak-time2 18 duration 120 avg-rate ?
<1-4294967> Average rate in kbits/sec
Router(enforce-rule)# $ 180 avg-rate 2 peak-time2 18 duration 120 avg-rate 3 ?
duration      Off-peak duration
sample-interval Rate of sampling in minutes
Router(enforce-rule)# $ 180 avg-rate 2 peak-time2 18 duration 120 avg-rate 3 d
Router(enforce-rule)# $-time2 18 duration 120 avg-rate 3 duration 120 ?
avg-rate      Off-peak average rate in kbits/sec
Router(enforce-rule)# $duration 120 avg-rate 3 duration 120 avg-rate 1 ?

sample-interval Rate of sampling in minutes
Router(enforce-rule)# $40 avg-rate 3 duration 120 avg-rate 1 sample-interval ?
<1-30> Sampling rate in Minutes
Router(enforce-rule)# $e 3 duration 120 avg-rate 1 sample-interval 15 ?

downstream      downstream
upstream        upstream
Router(enforce-rule)# $e 3 duration 120 avg-rate 1 sample-interval 15 upstream ?
enforce         enforce the qos-profile automatically
<cr>
Router(enforce-rule)# $on 120 avg-rate 1 sample-interval 15 upstream enforce
Router(enforce-rule)# enabled
Router(enforce-rule)# end

```

## Configuring Weekend Monitoring

This section describes the tasks required to configure weekend monitoring for STM on a Cisco CMTS router.

### Prerequisites

You must first configure the weekday monitoring parameters for an enforce-rule before configuring weekend monitoring. See the [Creating and Configuring an Enforce-Rule, on page 1515](#).

### Restrictions

- Up to 40 total enforce-rules across both upstream and downstream configurations are supported.
- When using SNMP for weekend monitoring, only SNMP GET and GETMANY operations are supported.

### Configuring Different Legacy Monitoring Conditions for Weekends

Use the following procedure if you want to establish different legacy monitoring conditions for subscribers for either upstream or downstream traffic on weekend days.

## Procedure

|               | Command or Action                                                                                                                                                                                                                                                                                                                          | Purpose                                                                                              |
|---------------|--------------------------------------------------------------------------------------------------------------------------------------------------------------------------------------------------------------------------------------------------------------------------------------------------------------------------------------------|------------------------------------------------------------------------------------------------------|
| <b>Step 1</b> | <b>enable</b><br><b>Example:</b><br><br>Router> <b>enable</b>                                                                                                                                                                                                                                                                              | Enables privileged EXEC mode. Enter your password if prompted.                                       |
| <b>Step 2</b> | <b>configure terminal</b><br><b>Example:</b><br><br>Router# <b>configure terminal</b>                                                                                                                                                                                                                                                      | Enters global configuration mode.                                                                    |
| <b>Step 3</b> | <b>cable qos enforce-rule <i>name</i></b><br><b>Example:</b><br><br>Router(config)# <b>cable qos enforce-rule test</b>                                                                                                                                                                                                                     | Accesses the enforce-rule with the specified <i>name</i> and enters enforce-rule configuration mode. |
| <b>Step 4</b> | <b>weekend duration <i>minutes</i> <i>avg-rate</i> <i>rate</i> <i>sample-interval</i> <i>minutes</i> {<i>downstream</i>   <i>upstream</i>} [<i>penalty</i> <i>minutes</i>] [<i>enforce</i>]</b><br><b>Example:</b><br><br>Router(enforce-rule)# <b>weekend duration 120 avg-rate 500 sample-interval 15 penalty 120 downstream enforce</b> | Specifies the time period and sample rate used for monitoring subscribers on weekends.               |
| <b>Step 5</b> | <b>end</b><br><b>Example:</b><br><br>Router(enforce-rule)# <b>end</b>                                                                                                                                                                                                                                                                      | Exits enforce-rule configuration mode and returns to privileged EXEC mode.                           |

## Configuring Different Peak-Offpeak Monitoring Conditions for Weekends

Use the following procedure if you want to establish different peak and offpeak monitoring conditions for subscribers for either upstream or downstream traffic on weekend days.

## Procedure

|               | Command or Action                                             | Purpose                                                        |
|---------------|---------------------------------------------------------------|----------------------------------------------------------------|
| <b>Step 1</b> | <b>enable</b><br><b>Example:</b><br><br>Router> <b>enable</b> | Enables privileged EXEC mode. Enter your password if prompted. |
| <b>Step 2</b> | <b>configure terminal</b><br><b>Example:</b>                  | Enters global configuration mode.                              |

|               | Command or Action                                                                                                                                                                                                                                                                                                                                                                                                                                                                                                                                                                                                                                                                                                                                                                                                                                                           | Purpose                                                                                              |
|---------------|-----------------------------------------------------------------------------------------------------------------------------------------------------------------------------------------------------------------------------------------------------------------------------------------------------------------------------------------------------------------------------------------------------------------------------------------------------------------------------------------------------------------------------------------------------------------------------------------------------------------------------------------------------------------------------------------------------------------------------------------------------------------------------------------------------------------------------------------------------------------------------|------------------------------------------------------------------------------------------------------|
|               | Router# <code>configure terminal</code>                                                                                                                                                                                                                                                                                                                                                                                                                                                                                                                                                                                                                                                                                                                                                                                                                                     |                                                                                                      |
| <b>Step 3</b> | <b>cable qos enforce-rule</b> <i>name</i><br><b>Example:</b><br>Router(config)# <code>cable qos enforce-rule test</code>                                                                                                                                                                                                                                                                                                                                                                                                                                                                                                                                                                                                                                                                                                                                                    | Accesses the enforce-rule with the specified <i>name</i> and enters enforce-rule configuration mode. |
| <b>Step 4</b> | <b>weekend peak-time1</b> { <i>hour</i>   <i>hour:minutes</i> } <b>duration</b> <i>minutes</i> <b>avg-rate</b> <i>rate</i> [ <b>peak-time2</b> <i>hour</i> <b>duration</b> <i>minutes</i> <b>avg-rate</b> <i>rate</i> ] [ <b>duration</b> <i>offpeak-minutes</i> <b>avg-rate</b> <i>offpeak-rate</i> ] <b>sample-interval</b> <i>minutes</i> [ <b>penalty</b> <i>minutes</i> ] { <b>downstream</b>   <b>upstream</b> } [ <b>enforce</b> ]<br><b>Example:</b><br>Router(enforce-rule)# <code>weekend peak-time1 9 duration 120 avg-rate 2 peak-time2 16 duration 120 avg-rate 2 duration 120 avg-rate 3 sample-interval 15 upstream enforce</code><br><b>Example:</b><br>Router(enforce-rule)# <code>weekend peak-time1 9:30 duration 120 avg-rate 2 peak-time2 16:58 duration 180 avg-rate 2 duration 120 avg-rate 3 sample-interval 15 penalty 120 upstream enforce</code> | Specifies peak and offpeak monitoring times on weekends.                                             |
| <b>Step 5</b> | <b>end</b><br><b>Example:</b><br>Router(enforce-rule)# <code>end</code>                                                                                                                                                                                                                                                                                                                                                                                                                                                                                                                                                                                                                                                                                                                                                                                                     | Exits enforce-rule configuration mode and returns to privileged EXEC mode.                           |

## Disabling Weekend Monitoring

Use the following procedure to turn off the weekend monitoring configuration and monitor on weekdays only.

### Procedure

|               | Command or Action                                                                       | Purpose                                                        |
|---------------|-----------------------------------------------------------------------------------------|----------------------------------------------------------------|
| <b>Step 1</b> | <b>enable</b><br><b>Example:</b><br>Router> <code>enable</code>                         | Enables privileged EXEC mode. Enter your password if prompted. |
| <b>Step 2</b> | <b>configure terminal</b><br><b>Example:</b><br>Router# <code>configure terminal</code> | Enters global configuration mode.                              |

|               | Command or Action                                                                                                  | Purpose                                                                                              |
|---------------|--------------------------------------------------------------------------------------------------------------------|------------------------------------------------------------------------------------------------------|
| <b>Step 3</b> | <b>cable qos enforce-rule</b> <i>name</i><br><b>Example:</b><br>Router(config)# <b>cable qos enforce-rule test</b> | Accesses the enforce-rule with the specified <i>name</i> and enters enforce-rule configuration mode. |
| <b>Step 4</b> | <b>weekend off</b><br><b>Example:</b><br>Router(enforce-rule)# <b>weekend off</b>                                  | Disables monitoring on weekends.                                                                     |
| <b>Step 5</b> | <b>end</b><br><b>Example:</b><br>Router(enforce-rule)# <b>end</b>                                                  | Exits enforce-rule configuration mode and returns to privileged EXEC mode.                           |

## Removing Weekend Monitoring Conditions and Use the Same Monitoring Criteria Every Day

Use the following procedure to remove the specified weekend monitoring conditions and use the same monitoring criteria all week (including weekends).

### Procedure

|               | Command or Action                                                                                                  | Purpose                                                                                              |
|---------------|--------------------------------------------------------------------------------------------------------------------|------------------------------------------------------------------------------------------------------|
| <b>Step 1</b> | <b>enable</b><br><b>Example:</b><br>Router> <b>enable</b>                                                          | Enables privileged EXEC mode. Enter your password if prompted.                                       |
| <b>Step 2</b> | <b>configure terminal</b><br><b>Example:</b><br>Router# <b>configure terminal</b>                                  | Enters global configuration mode.                                                                    |
| <b>Step 3</b> | <b>cable qos enforce-rule</b> <i>name</i><br><b>Example:</b><br>Router(config)# <b>cable qos enforce-rule test</b> | Accesses the enforce-rule with the specified <i>name</i> and enters enforce-rule configuration mode. |
| <b>Step 4</b> | <b>no weekend</b><br><b>Example:</b><br>Router(enforce-rule)# <b>no weekend</b>                                    | Performs monitoring on the weekends using the same parameters for weekdays and weekends.             |
| <b>Step 5</b> | <b>end</b><br><b>Example:</b>                                                                                      | Exits enforce-rule configuration mode and returns to privileged EXEC mode.                           |

|  | Command or Action                      | Purpose |
|--|----------------------------------------|---------|
|  | <code>Router(enforce-rule)# end</code> |         |

## Disabling an Enforce-Rule

Use the following procedure to disable an enforce-rule. The enforce-rule remains in the CMTS configuration file, but any subscriber traffic management that uses this enforce-rule ends.

### Procedure

|               | Command or Action                                                                                                | Purpose                                                                                                                                                                  |
|---------------|------------------------------------------------------------------------------------------------------------------|--------------------------------------------------------------------------------------------------------------------------------------------------------------------------|
| <b>Step 1</b> | <b>enable</b><br><b>Example:</b><br><code>Router&gt; enable</code>                                               | Enables privileged EXEC mode. Enter your password if prompted.                                                                                                           |
| <b>Step 2</b> | <b>configure terminal</b><br><b>Example:</b><br><code>Router# configure terminal</code>                          | Enters global configuration mode.                                                                                                                                        |
| <b>Step 3</b> | <b>cable qos enforce-rulename</b><br><b>Example:</b><br><code>Router(config)# cable qos enforce-rule test</code> | Creates an enforce-rule with the specified <i>name</i> and enters enforce-rule configuration mode.                                                                       |
| <b>Step 4</b> | <b>no enabled</b><br><b>Example:</b><br><code>Router(enforce-rule)# no enabled</code>                            | Disables the enforce-rule and ends subscriber traffic management for users with the rule's registered QoS profile. It moves all modems in penalty to its registered QoS. |
| <b>Step 5</b> | <b>end</b><br><b>Example:</b><br><code>Router(enforce-rule)# end</code>                                          | Exits enforce-rule configuration mode and returns to privileged EXEC mode.                                                                                               |

## Removing an Enforce-Rule

Use the following procedure to delete an enforce-rule and remove it from the CMTS configuration file. Any subscriber traffic management that uses this rule also ends.

## Procedure

|               | Command or Action                                                                                                       | Purpose                                                                                                                                                                                                    |
|---------------|-------------------------------------------------------------------------------------------------------------------------|------------------------------------------------------------------------------------------------------------------------------------------------------------------------------------------------------------|
| <b>Step 1</b> | <b>enable</b><br><b>Example:</b><br><br>Router> <b>enable</b>                                                           | Enables privileged EXEC mode. Enter your password if prompted.                                                                                                                                             |
| <b>Step 2</b> | <b>configure terminal</b><br><b>Example:</b><br><br>Router# <b>configure terminal</b>                                   | Enters global configuration mode.                                                                                                                                                                          |
| <b>Step 3</b> | <b>no cable qos enforce-rulename</b><br><b>Example:</b><br><br>Router(config)# <b>no cable qos enforce-rule ef-rule</b> | Deletes the enforce-rule with the specified <i>name</i> . This enforce-rule and its configuration are removed from the CMTS configuration, and any subscriber traffic management that uses this rule ends. |
| <b>Step 4</b> | <b>end</b><br><b>Example:</b><br><br>Router(config)# <b>end</b>                                                         | Exits global configuration mode and returns to privileged EXEC mode.                                                                                                                                       |

## Changing a Cable Modem Service Class

Use the following procedure to change a QoS service class for a particular DOCSIS 1.1 cable modem.



### Restriction

- The command is supported only on DOCSIS 1.1 CM primary service flows.
- You can specify the **cable modem service-class-name** command only after the CM has been online for at least 200 seconds.
- The parameters defined by the named service class should always be a compatible subset of the registered set of parameters for the CM. Only certain options can be changed using a CMTS router service class, such as the **max-rate**, **priority**, or **tos-overwrite** options. The **max-burst** option in both the enforced and registered CMTS router service classes must strictly match the value for **max-burst** in the registered DOCSIS configuration file. If the service class value does not match, then CM registration will fail with a reject-c state, or the enforced class will fail.

## Procedure

|               | Command or Action                                             | Purpose                                                        |
|---------------|---------------------------------------------------------------|----------------------------------------------------------------|
| <b>Step 1</b> | <b>enable</b><br><b>Example:</b><br><br>Router> <b>enable</b> | Enables privileged EXEC mode. Enter your password if prompted. |



|        | Command or Action                                                                                                                                                                        | Purpose                                                   |
|--------|------------------------------------------------------------------------------------------------------------------------------------------------------------------------------------------|-----------------------------------------------------------|
| Step 2 | <b>cable modem</b> {ip-address   mac-address}<br><b>service-class-name</b> name<br><br><b>Example:</b><br><br>Router# <b>cable modem</b> aaa.bbbb.cccc<br><b>service-class-name</b> test | Changes a QoS service class for a particular cable modem. |
| Step 3 | <b>end</b><br><br><b>Example:</b><br><br>Router# <b>end</b>                                                                                                                              | Exits privileged EXEC mode.                               |

## Monitoring the Subscriber Traffic Management Feature on the Cisco CMTS Routers

This section describes the following tasks that can be used to monitor the Subscriber Traffic Management feature:

### Displaying the Currently Defined Enforce-Rules

To display all enforce-rules that are currently defined on the Cisco CMTS router, or the definitions for a particular enforce-rule, use the **show cable qos enforce-rule** command in privileged EXEC mode.

For offpeak monitoring, use the **show cable qos enforce-rule** command to display the monitoring duration and average-rate values applicable for that time of day. If no monitoring is taking place, 0 is displayed.

The following example shows sample output from the **show cable qos enforce-rule** command for all configured enforce-rules:

```
Router# show cable qos enforce-rule
      Name                Dur  Dir byte-cnt Auto rate  penalty Reg  Enf  Ena  Persist
      (min)              (kbytes) enf (min) (min)  QoS QoS
residential              10  us   5         act  1    10080  5   10  Yes  Yes
ef-q11d                  30  ds  150        act  1     20    11  99  Yes  Yes
ef-q11u                  30  us   60        act  1     20    11  99  Yes  Yes
ef-q21                   720 us   60        act  1     10    21  81  Yes  Yes
ef-q21d                 300 ds  150        act  1     10    21  81  Yes  Yes
ef-q22                   720 us   60        act  1     10    22  82  Yes  Yes
ef-q22d                 300 ds  150        act  1     10    22  82  Yes  No
ef-q23                   720 us   60        act  1     10    23  83  Yes  Yes
ef-q23d                 300 ds  150        act  1     10    23  83  Yes  Yes
ef-q24                   720 us   60        act  1     10    24  84  Yes  Yes
ef-q24d                 300 ds  150        act  1     10    24  84  Yes  Yes
ef-q25                   720 us   60        act  1     10    25  85  Yes  Yes
ef-q25d                 300 ds  150        act  1     10    25  85  Yes  Yes
ef-q26                   720 us   60        act  1     10    26  86  Yes  Yes
ef-q26d                 300 ds  150        act  1     10    26  86  Yes  Yes
ef-q27                   720 us   60        act  1     10    27  87  Yes  Yes
ef-q27d                 300 ds  150        act  1     10    27  87  Yes  Yes
ef-q28                   720 us   60        act  1     10    28  88  Yes  Yes
```

```

ef-q28d                300 ds 150      act 1    10      28 88 Yes No
ef-q5d                 300 ds 150      act 1    10       5 99 Yes Yes
ef-q5u                 720 us 600      act 1    10       5 99 Yes Yes

```

The following example shows sample output from the **show cable qos enforce-rule** command for a particular enforce-rule named “test”:

```

Router# show cable qos enforce-rule test
      Name          Type Dur  Dir Avg-rate Auto rate   Reg      Enf      En Per
              (min)      kbits/s  enf (min)
test          p-off 120   us 1      act 10    255      4        Y  Y

```

The following example shows the sample output from the **show cable qos enforce-rule verbose** command for an enforce-rule named “test”:

```

Router# show cable qos enforce-rule test verbose
Name                : test
Version             : docsis11
Monitoring Type     : peak-offpeak
Registered          : REG-DS
Enforced            : ENF-DS
Monitoring Duration : 70 (in minutes)
Sample-rate         : 10 (in minutes)
Average-rate        : 3 kbits/sec
Direction           : downstream
Auto Enforce        : Yes
Current Penalty Duration : 10 (in minutes)
Default Penalty Duration : 10 (in minutes)
Penalty End-time    : 23:0 (time of day)
Rule Enabled        : Yes
Persistence         : Yes
Weekend             : No
Penalty Off         : No
Monitor Weekend     : Yes
Monitoring after RelTime : Off
First Peak Time     : 10:0
Duration            : 120 (in minutes)
First Average-rate  : 1 kbits/sec
Second Peak Time    : 19:0
Duration            : 120 (in minutes)
Second Average-rate : 2 kbits/sec
Offpeak Duration    : 70 (in minutes)
Offpeak Average-rate : 3 kbits/sec
Auto Enforce        : Yes
Sample Rate         : 10
Penalty-Period for week-days : 0
Weekend First Peak Time : 11:0
Weekend Duration    : 75 (in minutes)
Weekend First Average-rate : 4 kbits/sec
Weekend Second Peak Time : 20:0
Weekend Duration    : 80 (in minutes)
Weekend Second Average-rate : 5 kbits/sec
Weekend Offpeak Duration : 85 (in minutes)
Weekend Offpeak Average-rate : 6 kbits/sec
Weekend Auto Enforce : Yes
Weekend Sample Rate : 12
Penalty-Period for week-ends : 0
router#sh clock
*17:30:50.259 UTC Mon Apr 19 2010

```

The following example shows sample output from the **show cable qos enforce-rule verbose** command for a particular enforce-rule named “test” that has specified peak-offpeak weekend monitoring options:

```

Router# show cable qos enforce-rule test verbose
Name : test
Version : docsis10
Monitoring Type : peak-offpeak
Registered : 255
Enforced : 4
Monitoring Duration : 120 (in minutes)
Sample-rate : 10 (in minutes)
Average-rate : 1 kbits/sec
Direction : upstream
Penalty Time : 10080 (in minutes)
Penalty End-time : 23 (time of day in hrs)
Rule Enabled : Yes
Persistence : Yes
Week-end : Yes
First Peak Time : 6
Duration : 120 (in minutes)
First Average-rate : 2 kbits/sec
Second Peak Time : 18
Duration : 120 (in minutes)
Second Average-rate : 3 kbits/sec
Offpeak Duration : 120 (in minutes)
Offpeak Average-rate : 1 kbits/sec
Auto-enforce : active
Weekend First Peak Time : 8
Weekend First Duration : 120 (in minutes)
Weekend First Average-rate : 2 kbits/sec
Weekend Second Peak Time : 18
Weekend Second Duration : 180 (in minutes)
Weekend Second Average-rate : 5 kbits/sec
Weekend Offpeak Duration : 240 (in minutes)
Weekend Offpeak Average-rate : 4 kbits/sec
Weekend Auto-enforce : active

```

## Displaying the Current Subscriber Usage

To display the usage for all subscribers on a cable interface, use the `show cable subscriber-usage` command in privileged EXEC mode without any options.

To display the usage for just those subscribers who are violating their registered quality of service (QoS) profiles, use the `show cable subscriber-usage over-consume` form of the command.

The following example shows sample output from the `show cable subscriber-usage` command for all users on the specified cable interface:

```

Router# show cable subscriber-usage cable 6/0/1
Sfid Mac Address  Enforce-rule  Total-Kbyte  Last-detect  Last-penalty  Pen
                Name          Count        time         time         Flag
3    0007.0e03.110d  efrule-q5    121944817   Jan1 03:44:08   Jan1 03:54:08   Act
4    0007.0e03.110d  efrule-q5d   1879076068  Jan1 03:35:05   Jan1 03:45:06   Act
5    0007.0e03.1431  efrule-q5    120052387   Jan1 03:44:18   Jan1 03:54:18   Act
6    0007.0e03.1431  efrule-q5d   1838493626  Jan1 03:34:55   Jan1 03:44:55   Act
7    0007.0e03.1445  efrule-q5    120919427   Jan1 03:44:08   Jan1 03:54:08   Act
8    0007.0e03.1445  efrule-q5d   1865955172  Jan1 03:35:06   Jan1 03:45:06   Act
9    0007.0e03.1225  efrule-q5    120200155   Jan1 03:44:18   Jan1 03:54:18   Act
10   0007.0e03.1225  efrule-q5d   1839681070  Jan1 03:34:55   Jan1 03:44:55   -
11   0007.0e03.0cb1  efrule-q5    122941643   Jan1 03:43:58   Jan1 03:53:58   Act
12   0007.0e03.0cb1  efrule-q5d   1889107176  Jan1 03:35:06   Jan1 03:45:06   Act
13   0007.0e03.1435  efrule-q5    119504795   Jan1 03:44:18   Jan1 03:54:18   Act
14   0007.0e03.1435  efrule-q5d   1835164034  Jan1 03:34:55   Jan1 03:44:55   -

```

By default, the display is sorted by the service flow ID (SFID). To sort the display by the subscriber byte count, with the largest byte counts listed first, use the **sort-byte-count** option. The following example shows sample output for **show cable subscriber-usage sort-byte-count** form of the command:



**Note** The **sort-byte-count** option was replaced by the **sort-avg-rate** option.

```
Router# show cable subscriber-usage
sort-byte-count
```

| Sfid | Mac Address    | Enforce-rule Name | Total-Kbyte Count | Last-detect time | Last-penalty time | Pen Flag |
|------|----------------|-------------------|-------------------|------------------|-------------------|----------|
| 7    | 0007.0e03.2cad | test1             | 65157114          | Feb24 11:36:34   | Mar3 11:36:34     | Act      |
| 9    | 0007.0e03.2c45 | test1             | 16381014          |                  |                   | -        |
| 5    | 0007.0e03.2c25 | test1             | 13440960          |                  |                   | -        |

## Configuration Examples for Subscriber Traffic Management on the Cisco CMTS Routers

This section lists sample configurations for the Subscriber Traffic Management feature on a CMTS router:

### Example: DOCSIS Configuration File and STM Service Classes

The following example shows a sample DOCSIS configuration file along with sample registered and enforced QoS service classes that you could define on a Cisco CMTS router to perform subscriber traffic management.

#### DOCSIS Configuration File Options

This is an example of a very basic set of options that you can configure for a cable modem in your DOCSIS configuration file that supports a successful configuration of new QoS service class options on the Cisco CMTS router.



**Note** There are certain QoS parameters that cannot be changed from the registered QoS parameter set and a new service class. For example, the **max-burst** value must match the originally registered in the DOCSIS configuration file, and the registered and enforced QoS service classes on the Cisco CMTS router. If the **max-burst** value differs from the registered CMTS service class and the DOCSIS configuration file, the CM might go into reject-c state, or the enforced class could fail.

The following example shows the configuration of two service classes named “BE-STM-US-1” and “BE-STM-DS-1” in a DOCSIS configuration file to define a basic set of upstream and downstream parameters:

```
03 (Net Access Control) = Yes
17 (Baseline Privacy Block)
S01 (Authorize Wait Timeout) = 10
18 (Maximum Number of CPE) = 10
24 (Upstream Service Flow Block)
S01 (Flow Reference) = 1
```

```
S04 (Service Class Name) = BE-STM-US-1
S06 (QoS Parameter Set Type) = 7
25 (Downstream Service Flow Block)
S01 (Flow Reference) = 2
S04 (Service Class Name) = BE-STM-DS-1
S06 (QoS Parameter Set Type) = 7
29 (Privacy Enable) = Yes
```

The following example shows sample **cable service class**

commands on the Cisco CMTS router for configuration of subscriber traffic management that correspond to the service class names in the DOCSIS configuration file of "BE-STM-US-1" and "BE-STM-DS-1." These service classes correspond to the registered service classes configured by the **service-class registered**

command for the QoS enforce-rules shown later in this example:

```
cable service class 2 name BE-STM-US-1
cable service class 2 upstream
cable service class 2 max-rate 2000000
cable service class 2 max-burst 3044
cable service class 2 max-concat-burst 8000
cable service class 3 name BE-STM-DS-1
cable service class 3 downstream
cable service class 3 max-rate 30000000
cable service class 3 max-concat-burst 8000
```

For the cable modem to achieve maximum US throughput, provide a large value to the max-concat-burst keyword in the cable service class command.

The following example shows sample **cable service class** commands on the Cisco CMTS router that configure new QoS parameters for identified subscribers to limit bandwidth using the **max-rate** parameter. These service classes correspond to the enforced service classes configured by the **service-class enforced** command for the QoS enforce rules shown later in this example:

```
cable service class 102 name BEUS-1
cable service class 102 upstream
cable service class 102 max-rate 48888
cable service class 102 max-burst 3044
cable service class 102 max-concat-burst 8000
cable service class 103 name BEDS-1
cable service class 103 downstream
cable service class 103 max-rate 988888
cable service class 103 max-concat-burst 8000
```

The following example shows configuration of the corresponding enforce-rules for upstream and downstream monitoring, which identifies the registered and enforced service classes:

```
cable qos enforce-rule US-1
  monitoring-basics legacy docsis11
  penalty-period 120
  service-class registered BE-STM-US-1
  service-class enforced BEUS-1
  duration 120 avg-rate 1 sample-interval 15 up enf
  enabled
!
cable qos enforce-rule DS-1
  monitoring-basics legacy docsis11
  penalty-period 120
  service-class registered BE-STM-DS-1
  service-class enforced BEDS-1
  duration 120 avg-rate 1 sample-interval 15 do enf
  enabled
```

## Example: Downstream Configuration

The following example shows a typical enforce-rule configuration for traffic in the downstream direction:

```
!
cable qos enforce-rule downstream-rule
  monitoring-basics legacy docsis11
  penalty-period 120
  service-class registered class5
  service-class enforced class99
  duration 120 avg-rate 1 sample-interval 15 downstream enforce
  enabled
```

## Example: Upstream Configuration

The following example shows a typical enforce-rule configuration for traffic in the upstream direction:

```
!
cable qos enforce-rule upstream-rule
  monitoring-basics legacy docsis11
  penalty-period 120
  service-class registered class5
  service-class enforced class99
  duration 120 avg-rate 1 sample-interval 15 upstream enforce
  enabled
```

## Example: Downstream and Upstream Configuration

The following example shows a typical enforce-rule configuration for traffic in both the downstream and upstream directions. Two separate rules are created, using the identical configuration, except for the keywords **upstream** and **downstream** in the **duration** command.



---

**Note** The enforce rules for the upstream and downstream directions can use either an identical configuration, or they can use their own individual configurations.

---

```
!
cable qos enforce-rule upstream-rule
  monitoring-basics legacy docsis11
  penalty-period 120
  service-class registered class5
  service-class enforced class99
  duration 120 avg-rate 5 sample-interval 15 upstream enforce
  enabled
cable qos enforce-rule downstream-rule
  monitoring-basics legacy docsis11
  penalty-period 120
  service-class registered class5
  service-class enforced class99
  duration 120 avg-rate 5 sample-interval 15 downstream enforce
  enabled
```

The following example shows an enforce-rule configuration for traffic in upstream direction. A unique penalty duration is configured for upstream, with monitoring turned on after the penalty release time.



**Note** For upstream direction, a unique penalty duration (120 minutes) is configured, which takes precedence over the duration configured using the penalty-period command (60 minutes). A fresh monitoring starts after the penalty release time (23:00), when all the traffic counters are reset to 0.

```
!
cable qos enforce-rule upstream_rule
  monitoring-basics peak-offpeak docsis10
  penalty-period 120 time-of-day 23:00 monitoring-on
  qos-profile registered 6
  qos-profile enforced 100
  peak-time1 10:30 duration 120 avg-rate 10 peak-time2 22:10 duration 60 avg-rate 10
sample-interval 15 penalty 120 upstream enforce
enabled
```

## Example: Weekend Monitoring Configuration

The following example shows a sample configuration of peak-offpeak weekend monitoring for DOCSIS 1.0 cable modems:

```
cable qos enforce-rule monitoring
  monitoring-basics peak-offpeak docsis10
  penalty-period 120
  qos-profile registered 6
  qos-profile enforced 100
  peak-time1 10 duration 120 avg-rate 10 peak-time2 23 duration 120 avg-rate 10
sample-interval 15 upstream enforce
  weekend peak-time1 8 duration 120 avg-rate 100 peak-time2 20 duration 120 avg-rate 10000
  duration 120 avg-rate 20000 sample-interval 15 downstream enforce
enabled
```

## Additional References

For additional information related to the Subscriber Traffic Management feature, refer to the following references:

### Related Documents

| Related Topic  | Document Title                                         |
|----------------|--------------------------------------------------------|
| Cable commands | <a href="#">Cisco IOS CMTS Cable Command Reference</a> |

### Standards

| Standards <sup>7</sup>                | Title                                                                                                                                                                              |
|---------------------------------------|------------------------------------------------------------------------------------------------------------------------------------------------------------------------------------|
| <a href="#">SP-RFIV1.1-I09-020830</a> | <i>Data-over-Cable Service Interface Specifications Radio Frequency Interface Specification, version 1.1</i> ( <a href="http://www.cablemodem.com">http://www.cablemodem.com</a> ) |

| Standards <sup>7</sup>                           | Title                                                                                                    |
|--------------------------------------------------|----------------------------------------------------------------------------------------------------------|
| <a href="#">draft-ietf-ipcdn-docs-rfmibv2-06</a> | <i>Radio Frequency (RF) Interface Management Information Base for DOCSIS 2.0 Compliant RF Interfaces</i> |

<sup>7</sup> Not all supported standards are listed.

### MIBs

| MIBs <sup>8</sup>                                                                                         | MIBs Link                                                                                                                                                                                                                         |
|-----------------------------------------------------------------------------------------------------------|-----------------------------------------------------------------------------------------------------------------------------------------------------------------------------------------------------------------------------------|
| <ul style="list-style-type: none"> <li>• CISCO-CABLE-QOS-MONITOR-MIB</li> <li>• DOCSIS-QOS-MIB</li> </ul> | <p>To locate and download MIBs for selected platforms, Cisco IOS releases, and feature sets, use Cisco MIB Locator found at the following URL:</p> <p><a href="http://www.cisco.com/go/mibs">http://www.cisco.com/go/mibs</a></p> |

<sup>8</sup> Not all supported MIBs are listed.

### RFCs

| RFCs <sup>9</sup>        | Title                                               |
|--------------------------|-----------------------------------------------------|
| <a href="#">RFC 2233</a> | <a href="#">DOCSIS OSSI Objects Support</a>         |
| <a href="#">RFC 2665</a> | <a href="#">DOCSIS Ethernet MIB Objects Support</a> |
| <a href="#">RFC 2669</a> | <a href="#">Cable Device MIB</a>                    |

<sup>9</sup> Not all supported RFCs are listed.

### Technical Assistance

| Description                                                                                                                                                                                                                                                                                                                                                                                                                                                                                                                                                             | Link                                                                                                                     |
|-------------------------------------------------------------------------------------------------------------------------------------------------------------------------------------------------------------------------------------------------------------------------------------------------------------------------------------------------------------------------------------------------------------------------------------------------------------------------------------------------------------------------------------------------------------------------|--------------------------------------------------------------------------------------------------------------------------|
| <p>The Cisco Support website provides extensive online resources, including documentation and tools for troubleshooting and resolving technical issues with Cisco products and technologies.</p> <p>To receive security and technical information about your products, you can subscribe to various services, such as the Product Alert Tool (accessed from Field Notices), the Cisco Technical Services Newsletter, and Really Simple Syndication (RSS) Feeds.</p> <p>Access to most tools on the Cisco Support website requires a Cisco.com user ID and password.</p> | <p><a href="http://www.cisco.com/cisco/web/support/index.html">http://www.cisco.com/cisco/web/support/index.html</a></p> |



# Feature Information for Subscriber Traffic Management

Use Cisco Feature Navigator to find information about the platform support and software image support. Cisco Feature Navigator enables you to determine which software images support a specific software release, feature set, or platform. To access Cisco Feature Navigator, go to the <https://cfng.cisco.com/> link. An account on the Cisco.com page is not required.



**Note** The following table lists the software release in which a given feature is introduced. Unless noted otherwise, subsequent releases of that software release train also support that feature.

**Table 304: Feature Information for Subscriber Traffic Management**

| Feature Name                  | Releases                    | Feature Information                                                                                           |
|-------------------------------|-----------------------------|---------------------------------------------------------------------------------------------------------------|
| Subscriber traffic management | Cisco IOS XE Everest 16.6.1 | This feature was integrated into Cisco IOS XE Everest 16.6.1 on Cisco cBR Series Converged Broadband Routers. |





## CHAPTER 96

# Narrowband Digital Forward And Narrowband Digital Return

---

This document describes the narrowband digital forward and narrowband digital return feature.

- [Hardware Compatibility Matrix for the Cisco cBR Series Routers, on page 1535](#)
- [Information About NDF and NDR, on page 1537](#)
- [Restrictions for Configuring NDF and NDR, on page 1537](#)
- [Configure NDF and NDR, on page 1538](#)
- [Feature Information for Narrowband Digital Forward And Narrowband Digital Return, on page 1545](#)

## Hardware Compatibility Matrix for the Cisco cBR Series Routers



---

**Note** The hardware components that are introduced in a given Cisco IOS-XE Release are supported in all subsequent releases unless otherwise specified.

---

Table 305: Hardware Compatibility Matrix for the Cisco cBR Series Routers

| Cisco CMTS Platform                    | Processor Engine                                                                                                                                                                                  | Interface Cards                                                                                                                                                                                                                                                                                                                                                                                                                                                                                                                                                                                                                                                                                                                                                                                 |
|----------------------------------------|---------------------------------------------------------------------------------------------------------------------------------------------------------------------------------------------------|-------------------------------------------------------------------------------------------------------------------------------------------------------------------------------------------------------------------------------------------------------------------------------------------------------------------------------------------------------------------------------------------------------------------------------------------------------------------------------------------------------------------------------------------------------------------------------------------------------------------------------------------------------------------------------------------------------------------------------------------------------------------------------------------------|
| Cisco cBR-8 Converged Broadband Router | <p><b>Cisco IOS-XE Release 16.5.1 and Later Releases</b></p> <p>Cisco cBR-8 Supervisor:</p> <ul style="list-style-type: none"> <li>• PID—CBR-SUP-250G</li> <li>• PID—CBR-CCAP-SUP-160G</li> </ul> | <p><b>Cisco IOS-XE Release 16.5.1 and Later Releases</b></p> <p>Cisco cBR-8 CCAP Line Cards:</p> <ul style="list-style-type: none"> <li>• PID—CBR-LC-8D30-16U30</li> <li>• PID—CBR-LC-8D31-16U30</li> <li>• PID—CBR-RF-PIC</li> <li>• PID—CBR-RF-PROT-PIC</li> <li>• PID—CBR-CCAP-LC-40G</li> <li>• PID—CBR-CCAP-LC-40G-R</li> <li>• PID—CBR-CCAP-LC-G2-R</li> <li>• PID—CBR-SUP-8X10G-PIC</li> <li>• PID—CBR-2X100G-PIC</li> </ul> <p>Digital PICs:</p> <ul style="list-style-type: none"> <li>• PID—CBR-DPIC-8X10G</li> <li>• PID—CBR-DPIC-2X100G</li> </ul> <p>Cisco cBR-8 Downstream PHY Module:</p> <ul style="list-style-type: none"> <li>• PID—CBR-D31-DS-MOD</li> </ul> <p>Cisco cBR-8 Upstream PHY Modules:</p> <ul style="list-style-type: none"> <li>• PID—CBR-D31-US-MOD</li> </ul> |



**Note** Do not use DPICs (8X10G and 2x100G) to forward IP traffic, as it may cause buffer exhaustion, leading to line card reload.

The only allowed traffic on a DPIC interface is DEPI, UEPI, and GCP traffic from the Cisco cBR-8 router to Remote PHY devices. Other traffic such as DHCP, SSH, and UTSC should flow via another router, since DPICs cannot be used for normal routing.

## Information About NDF and NDR

Narrowband Digital Forward (NDF) refers to the digitizing of an analog portion of the downstream spectrum at the headend, sending the digital samples as payload in [DEPI] packets to the RPD, and then re-creating the original analog stream at the RPD. NDF supports services such as FM Broadcast, DAB+ Broadcast, and OOB signals for Forward Sweep, DS Leakage, and Element management.

Narrowband Digital Return (NDR) refers to the digitizing of an analog portion of the upstream spectrum at the RPD, sending the digital samples as payload in [R-UEPI] packets to the CMTS, and then re-creating the original analog stream at the headend. NDR supports legacy OOB signals for Reverse Sweep, Return Path Monitoring, FSK based HMS, and other FSK based telemetry signals.

## Restrictions for Configuring NDF and NDR

The following restrictions are applicable for configuring NDF and NDR:

### 1x2 RPD

#### NDF

- Supports a maximum of three narrow band NDF channels if OOB 55-1 or OOB 55-2 is not configured. Only channel ID 0, 1 and 2 can be used for 1x2 RPD, channel ID 3 is not supported and will be rejected by 1x2 RPD.
- If OOB 55-1 DS is configured, only one NDF channel is supported. OOB 55-1 DS uses first and the second OOB channel while NDF uses the third OOB channel. If 55-1 DS is configured after configuring NDF, ensure that not more than one NDF channel is configured.
- If OOB 55-2 is configured, two NDF channels are supported. OOB 55-2 uses the first OOB channel.
- Supports NDF Mode 0 to Mode 6. NDF Mode 7 is not supported.

#### NDR

- Each upstream port supports three OOB channels. OOB 55-1 and OOB 55-2 channels share the upstream OOB resource with NDR channels.
- If two OOB 55-1 channels are configured on upstream port 0, then only one NDR channel is supported on port 0, and up to three NDR channels are supported on port 1.
- If one OOB 55-2 upstream channel is configured on a port, then either one mode 6 (5.12 MHz) NDR can be configured or 2 NDR with mode 5 or lesser can be configured.
- NDR Mode 0 (80 KHz) is not supported.

### 2x2 RPD

Starting from Cisco IOS XE Amsterdam 17.2.1, 4 NDF (3 narrowband and 1 wideband) sessions are supported.

# Configure NDF and NDR

To configure NDF and NDR, perform these steps.

1. Configure static-pseudowires for NDF and NDR.
2. Configure NDF and NDR profiles.
3. Bind static-pseudowires and profiles with RPD.

## Configure Static-Pseudowires for NDF and NDR



**Note**

- For NDF static pseudowire, session ID must be unique within a rf-port across all rf-channels configured in that port.
- For NDR static pseudowire, the session ID and the server IP must be unique within a RPD.

To configure NDF static-pseudowires, run the following commands:

```
Router# enable
Router# configure terminal
Router(config)# cable oob
Router(config-oob)# [no] static-pseudowire <name> type ndf [id <id>]
Router(config-oob-spw)# [no] dest-ip <ipv4/ipv6 addr> [source-ip <ipv4 | ipv6 addr>]
Router(config-oob-spw)# [no] session-id <session id>
```

To configure NDR static-pseudowires, run the following commands:

```
Router# enable
Router# configure terminal
Router(config)# cable oob
Router(config-oob)# [no] static-pseudowire <name> type ndr [id <id>]
Router(config-oob-spw)# [no] server-ip <ipv4/ipv6 addr>
Router(config-oob-spw)# [no] mtusize <mtu size value>
Router(config-oob-spw)# [no] per-hop-behavior <IP DSCP per hop behavior value>
Router(config-oob-spw)# [no] session-id <session id>
```

**Table 306: Syntax Description**

| Syntax | Description                                                                                                                                                                     |
|--------|---------------------------------------------------------------------------------------------------------------------------------------------------------------------------------|
| name   | Specify a unique name for the static-pseudowire. The name can be up to 30 characters long and is case sensitive. The name can be alphanumeric and underscore ( _ ) can be used. |
| id     | Specify a unique ID for the static-pseudowire. The valid range is from 1 to 4294967295.<br><br>If the ID is not specified, the system auto-generates an ID.                     |

| Syntax    | Description                                                                                                                                                                                                                                                                                                                                                                                               |
|-----------|-----------------------------------------------------------------------------------------------------------------------------------------------------------------------------------------------------------------------------------------------------------------------------------------------------------------------------------------------------------------------------------------------------------|
| dest-ip   | <p>For multicast NDF, specify the Group (Destination) IP address of the multicast group from which RPD has to receive data on a static pseudowire.</p> <p>For unicast NDF, the Group (Destination) IP address is set to 0.0.0.0 or 0::0. The Group (Destination) IP address can be IPv4 or IPv6.</p>                                                                                                      |
| source-ip | <p>For source specific multicast (SSM) group, specify the source IP address of the multicast group that RPD has to join to to receive data on a static pseudowire.</p> <p>For unicast NDF, specify the source IP address of the remote peer from which RPD has to receive data on a NDF static pseudowire.</p>                                                                                            |
| server-ip | Specify the destination IP address from which RPD has to receive data on a static pseudowire. The server IP can be IPv4 or IPv6 address.                                                                                                                                                                                                                                                                  |
| type      | Configure the static-pseudowire type. The static-pseudowire type is NDF or NDR.                                                                                                                                                                                                                                                                                                                           |
| mtusize   | <p>Specify the MTU (Maximum Transmission Unit) size supported by the CCAP Core on a return static pseudowire. MTU is the Layer 3 payload of a Layer 2 frame. The MtuSize attribute carries information equivalent to DEPI Local MTU. CCAP core can receive the configured MTU size from the RPD on the CIN interface.</p> <p>The valid range for MTU size is 1500–9216. The default MTU size is 1500.</p> |

| Syntax           | Description                                                                                                                                                                                                                                                                                                                                                                                                                                                                                                                                                                                                                                                                                                                                                                                                                                                                                                                                                                                                                                                                                                                                                                                                                                                                                                                                                                                                                                                                                                                                                                                                                            |
|------------------|----------------------------------------------------------------------------------------------------------------------------------------------------------------------------------------------------------------------------------------------------------------------------------------------------------------------------------------------------------------------------------------------------------------------------------------------------------------------------------------------------------------------------------------------------------------------------------------------------------------------------------------------------------------------------------------------------------------------------------------------------------------------------------------------------------------------------------------------------------------------------------------------------------------------------------------------------------------------------------------------------------------------------------------------------------------------------------------------------------------------------------------------------------------------------------------------------------------------------------------------------------------------------------------------------------------------------------------------------------------------------------------------------------------------------------------------------------------------------------------------------------------------------------------------------------------------------------------------------------------------------------------|
| per-hop-behavior | <p>Specify the Per Hop Behavior Identifier that is equal to the 6-bit DSCP with which the RPD transmits L2TPv3 data packets on the selected return static pseudowire. The per-hop-behavior configures information that is equivalent to the information configured by the PHBID field of the Upstream Flow. The upper two bits are set as 00 by the CCAP core and ignored by the RPD. The default value is 0.</p> <p>These standard QOS DSCP values are allowed to be selected in the CLI.</p> <p>af11 Match packets with AF11 dscp (001010)<br/> af12 Match packets with AF12 dscp (001100)<br/> af13 Match packets with AF13 dscp (001110)<br/> af21 Match packets with AF21 dscp (010010)<br/> af22 Match packets with AF22 dscp (010100)<br/> af23 Match packets with AF23 dscp (010110)<br/> af31 Match packets with AF31 dscp (011010)<br/> af32 Match packets with AF32 dscp (011100)<br/> af33 Match packets with AF33 dscp (011110)<br/> af41 Match packets with AF41 dscp (100010)<br/> af42 Match packets with AF42 dscp (100100)<br/> af43 Match packets with AF43 dscp (100110)<br/> cs1 Match packets with CS1(precedence 1) dscp (001000)<br/> cs2 Match packets with CS2(precedence 2) dscp (010000)<br/> cs3 Match packets with CS3(precedence 3) dscp (011000)<br/> cs4 Match packets with CS4(precedence 4) dscp (100000)<br/> cs5 Match packets with CS5(precedence 5) dscp (101000)<br/> cs6 Match packets with CS6(precedence 6) dscp (110000)<br/> cs7 Match packets with CS7(precedence 7) dscp (111000)<br/> default Match packets with default dscp (000000)<br/> ef Match packets with EF dscp (101110)</p> |
| session-id       | <p>Configure the session ID for the static pseudowire.</p> <p><b>Note</b> One session ID is configured for each static pseudowire as static pseudowires are defined in a single direction.</p>                                                                                                                                                                                                                                                                                                                                                                                                                                                                                                                                                                                                                                                                                                                                                                                                                                                                                                                                                                                                                                                                                                                                                                                                                                                                                                                                                                                                                                         |



## Configure NDF and NDR Profile



**Note** You can configure only one rf-channel in a NDF and NDR profile.

To configure NDF profile, run the following commands:

```
Router# enable
Router# configure terminal
Router(config)# [no] controller downstream-oob NDF-profile <profile id>
Router(config-profile)# [no] ds-channel <channel id> rf-mute
Router(config-profile)# [no] ds-channel <channel id> shutdown
Router(config-profile)# [no] ds-channel <channel id> frequency <frequency>
Router(config-profile)# [no] ds-channel <channel id> width <width>
Router(config-profile)# [no] ds-channel <channel id> poweradjust <power-adjust>
```

To configure NDR profile, run the following commands:

```
Router# enable
Router# configure terminal
Router(config)# [no] controller upstream-oob NDR-profile <profile id>
Router(config-profile)# [no] us-channel <channel id> shutdown
Router(config-profile)# [no] us-channel <channel id> frequency <frequency>
Router(config-profile)# [no] us-channel <channel id> width <width>
Router(config-profile)# [no] us-channel <channel id> poweradjust <power-adjust>
```

**Table 307: Syntax Description**

| Syntax      | Description                                                                                                                                                                                        |
|-------------|----------------------------------------------------------------------------------------------------------------------------------------------------------------------------------------------------|
| rf-mute     | Specify True to set the modulator in the muted diagnostic state. In the muted diagnostic state, the modulator does not transmit signal, but the operational status of the channel is not affected. |
| shutdown    | Set the administrative state of the selected NDF/NDR channel. Specifying shutdown removes all configuration from the channel. Specifying unshutdown retrieves all configuration of the channel.    |
| width       | Specify the total width of the spectrum in Hertz, including any required guardband.                                                                                                                |
| frequency   | Specify the frequency of the channel in Hertz.                                                                                                                                                     |
| poweradjust | Specify the power level adjustment for the NDF channel relative to the base power level configured for the DS RF port.                                                                             |

## Bind NDF Static-Pseudowire and NDF Profile with Rf-Port



### Note

- Destination IP address must be configured before binding NDF static-pseudowire to RPD. Once the destination IP address is bound, it cannot be removed, but can be updated.
- Frequency and channel width must be configured in NDF profile before binding NDF static-pseudowire to RPD. If frequency is configured, channel width cannot be removed or updated. To remove or update the channel width from the NDF profile, you must remove the frequency.
- To update frequency and channel width when the NDF profile is associated with the RPD, you must shut down the rf-channel in the NDF profile.

To bind NDF static-pseudowire and NDF profile with rf-port, execute the bind commands under **core-interface TenGigabitEthernet [interface]** command:

```
Router# configure terminal
Router(config)# cable rpd <rpdc name>
Router(config-rpd)# core-interface TenGigabitEthernet <interface>
Router(cable-rpd-core)# [no] rpd-ds <port id> static-pseudowire <name> profile <id>
```

## Bind NDR Static-Pseudowire and NDR Profile with Rf-Port



### Note

- Server IP address must be configured before binding NDR static-pseudowire to RPD. Once the server IP address is bound, it cannot be removed, but can be updated.
- Frequency and channel width must be configured in NDR profile before binding NDR static-pseudowire to RPD. If frequency is configured, channel width cannot be removed or updated. To remove or update the channel width from the NDR profile, you must remove the frequency.
- To update frequency and channel width when the NDR profile is associated with the RPD, you must shut down the rf-channel in the NDR profile.

To bind NDR static-pseudowire and NDR profile with rf-port, run the bind commands under **core-interface TenGigabitEthernet [interface]** command.

```
Router# configure terminal
Router(config)# cable rpd <rpdc name>
Router(config-rpd)# core-interface TenGigabitEthernet <interface>
Router(cable-rpd-core)# [no] rpd-us <port id> static-pseudowire <name> profile <id>
```

## Display TLV Status

To display the TLV status sent from cBR-8, run these commands:

```
Router# show cable rpd ndf-channels
```

```
Router# show cable rpd ndr-channels
```

To display per channel static-pseudowire and controller profile configuration, run these commands:

**Router# show cable rpd ndf-channels detailed**

**Router# show cable rpd ndr-channels detailed**

These examples show how to display the TLV status.

```
Router# show cable rpd ndf-channels
RPD-MAC-ID      Port  Chan  Session-Id  AdminState  Rf-Mute  Frequency  TLV-94-Status
0004.9f31.0785  0     0     0x88000001  NO SHUTDOWN NO MUTE   70000000  Failed-In-RPD
0004.9f31.0785  0     1     0x88000002  NO SHUTDOWN NO MUTE   72000000  RPD-Not-Capable
0004.9f31.0785  0     2     0x88000003  NO SHUTDOWN NO MUTE   74000000  RPD-Not-Capable
0004.9f31.0785  1     0     0x88000001  NO SHUTDOWN NO MUTE   70000000  RPD-Not-Capable
0004.9f31.0785  1     1     0x88000002  NO SHUTDOWN NO MUTE   72000000  RPD-Not-Capable
0004.9f31.0785  1     2     0x88000003  NO SHUTDOWN NO MUTE   74000000  RPD-Not-Capable
```

```
TLV-58-Status  RPD-NAME
Success-In-RPD RPD0-RACK1
RPD-Not-Capable RPD0-RACK1
RPD-Not-Capable RPD0-RACK1
RPD-Not-Capable RPD0-RACK1
RPD-Not-Capable RPD0-RACK1
RPD-Not-Capable RPD0-RACK1
```

```
Router# show cable rpd ndr-channels
RPD-MAC-ID      Port  Chan  Session-Id  AdminState  Frequency  TLV-95-Status
0004.9f31.0785  0     0     0x48000001  NO SHUTDOWN 5216000  Failed-In-RPD
0004.9f31.0785  0     1     0x48000002  NO SHUTDOWN 5216000  RPD-Not-Capable
0004.9f31.0785  0     2     0x48000003  NO SHUTDOWN 5416000  RPD-Not-Capable
0004.9f31.0785  1     0     0x48000001  NO SHUTDOWN 5216000  Failed-In-RPD
0004.9f31.0785  1     1     0x48000002  NO SHUTDOWN 5216000  RPD-Not-Capable
0004.9f31.0785  1     2     0x48000003  NO SHUTDOWN 5416000  RPD-Not-Capable
```

```
TLV-58-Status  RPD-NAME
Success-In-RPD RPD0-RACK1
RPD-Not-Capable RPD0-RACK1
RPD-Not-Capable RPD0-RACK1
Success-In-RPD RPD0-RACK1
RPD-Not-Capable RPD0-RACK1
RPD-Not-Capable RPD0-RACK1
```

**Table 308: TLV Status Description**

| TLV Status      | Description                                                                                                                                  |
|-----------------|----------------------------------------------------------------------------------------------------------------------------------------------|
| Success-In-RPD  | NDF/NDR configuration is sent to the RPD and RPD sends the response TLV with status as SUCCESS.                                              |
| Failed-In-RPD   | NDF/NDR configuration is sent to the RPD and RPD sends the response TLV with status as ERROR.                                                |
| Sent-To-RPD     | NDF/NDR configuration is sent to the RPD but no response is received from the RPD.                                                           |
| Failed-To-Send  | NDF/NDR TLV fails to deliver from CCAP core to RPD.                                                                                          |
| RPD-Not-Capable | RPD is not capable of supporting attributes in TLV. For example, if RPD does not support NDF or NDR, the TLV status sent as RPD-Not-Capable. |

| TLV Status  | Description                                                                                                                                                                                                                                    |
|-------------|------------------------------------------------------------------------------------------------------------------------------------------------------------------------------------------------------------------------------------------------|
| In-Progress | Frequency and channel width are set to 0 in a NDF or NDR profile. Depending on the TLV response from the RPD when frequency and channel width are configured and a no shutdown is performed on the rf-channel, the In-Progress status changes. |
| RPD-Offline | RPD is offline.                                                                                                                                                                                                                                |

## Example: NDF Configuration

This example shows how to configure static-pseudowire for NDF.

### Configure static-pseudowire for unicast NDF

```
Router# configure terminal
Router(config)# cable oob
Router(config-oob)# static-pseudowire ndf0 type ndf id 1
Router(config-oob-spw)# dest-ip 0.0.0.0 source-ip 192.168.1.10
Router(config-oob-spw)# session-id 0x1
```

### Configure static-pseudowire for multicast NDF

```
Router# configure terminal
Router(config)# cable oob
Router(config-oob)# static-pseudowire ndf2 type ndf id 12
Router(config-oob-spw)# dest-ip 232.1.1.10 source-ip 10.10.10.5
Router(config-oob-spw)# session-id 0x2
```

This example shows how to configure downstream OOB NDF profile.

```
Router# configure terminal
Router(config)# controller downstream-oob NDF-profile id 100
Router(config-profile)# no ds-channel 0 rf-mute
Router(config-profile)# no ds-channel 0 shutdown
Router(config-profile)# ds-channel 0 frequency 70000000
Router(config-profile)# ds-channel 0 width 1280000
Router(config-profile)# ds-channel 0 poweradjust -10
```

This example shows how to configure bind NDF static-pseudowire and NDF profile with rf-port.

```
Router# configure terminal
Router(config)# cable rpd node6
Router(config-rpd)# core-interface TenGigabitEthernet 7/1/0
Router(config-rpd-core)# rpd-ds 0 static-pseudowire ndf0 profile 100
Router(config-rpd-core)# rpd-ds 0 static-pseudowire ndf1 profile 101
Router(config-rpd-core)# rpd-ds 0 static-pseudowire ndf2 profile 102
```

## Example: NDR Configuration

This example shows how to configure static-pseudowire for NDR.

```
Router# configure terminal
Router(config)# cable oob
Router(config-oob)# static-pseudowire ndr0 type ndr id 19
Router(config-oob-spw)# server-ip 192.168.69.1
```

```
Router(config-oob-spw)# mtusize 1500
Router(config-oob-spw)# per-hop-behavior default
Router(config-oob-spw)# session-id 0x3
```

This example shows how to configure upstream OOB NDR profile.

```
Router# configure terminal
Router(config)# controller upstream-oob NDR-profile id 100
Router(config-profile)# no us-channel 0 shutdown
Router(config-profile)# us-channel 0 frequency 5216000
Router(config-profile)# us-channel 0 width 1280000
Router(config-profile)# us-channel 0 poweradjust -5
```

This example shows how to configure bind NDR static-pseudowire and NDR profile with rf-port.

```
Router# configure terminal
Router(config)# cable rpd node6
Router(config-rpd)# core-interface TenGigabitEthernet 7/1/0
Router(config-rpd-core)# rpd-us 0 static-pseudowire ndr0 profile 100
Router(config-rpd-core)# rpd-us 0 static-pseudowire ndr1 profile 101
Router(config-rpd-core)# rpd-us 0 static-pseudowire ndr2 profile 102
```

## Feature Information for Narrowband Digital Forward And Narrowband Digital Return

Use Cisco Feature Navigator to find information about the platform support and software image support. Cisco Feature Navigator enables you to determine which software images support a specific software release, feature set, or platform. To access Cisco Feature Navigator, go to the <https://cfng.cisco.com/> link. An account on the Cisco.com page is not required.



**Note** The following table lists the software release in which a given feature is introduced. Unless noted otherwise, subsequent releases of that software release train also support that feature.

**Table 309: Feature Information for Narrowband Digital Forward And Narrowband Digital Return**

| Feature Name                                             | Releases                       | Feature Information                                                      |
|----------------------------------------------------------|--------------------------------|--------------------------------------------------------------------------|
| Narrowband Digital Forward And Narrowband Digital Return | Cisco IOS XE Gibraltar 16.10.1 | This feature was introduced on the Cisco cBR Converged Broadband Router. |





## CHAPTER 97

# Differentiated Services Code Point Downstream

Differentiated Services Code Point (DSCP) is a packet header value marking that can be used to request priority traffic.

- [Information About Differentiated Services Code Point Downstream Marking, on page 1547](#)
- [Feature Information for Differentiated Services Code Point Downstream Marking, on page 1548](#)

## Information About Differentiated Services Code Point Downstream Marking

From Cisco IOS XE Amsterdam 17.3.x and later, Cisco cBR-8 Converged Broadband Router conforms to DOCSIS service's priority to drive traffic by high queue or low queue with various Differentiated Services Code Point Downstream (DSCP) marking. The following changes would apply:

- In high queue, L2TP traffic will be set to DSCP 40.
- In low queue, L2TP traffic will be set to DSCP 0.
- For the traffic with priority greater than or equal to the threshold, the L2TP packet's DSCP will be changed to CS5(40).

You might see the following message when you change the threshold:

```
Router# cable rphy flow downstream 3
High flow queue congestion may cause packets drop or jitter or latency is unexpectedly
increased. To avoid this, suggest the traffic in high queue less than 60% of full bandwidth
per line-card!
This change will take effect after modem reset and online again.
```

We recommend that you configure the traffic for less than 60% of full bandwidth per linecard in high-flow queue. The high-flow queue is designed for high priority traffic, and without the recommended configuration it may cause unexpected packet drop, jitter, or latency in high flow queue.

# Feature Information for Differentiated Services Code Point Downstream Marking

Use Cisco Feature Navigator to find information about the platform support and software image support. Cisco Feature Navigator enables you to determine which software images support a specific software release, feature set, or platform. To access Cisco Feature Navigator, go to the <https://cfng.cisco.com/> link. An account on the Cisco.com page is not required.



**Note** The following table lists the software release in which a given feature is introduced. Unless noted otherwise, subsequent releases of that software release train also support that feature.

**Table 310: Feature Information for Differentiated Services Code Point Downstream Marking**

| Feature Name                                          | Releases                       | Feature Information                                                      |
|-------------------------------------------------------|--------------------------------|--------------------------------------------------------------------------|
| Differentiated Services Code Point Downstream Marking | Cisco IOS XE Gibraltar 17.3.1w | This feature was introduced on the Cisco cBR Converged Broadband Router. |





## PART **XII**

# Security and Cable Monitoring Configuration

- [Dynamic Shared Secret, on page 1551](#)
- [Lawful Intercept Architecture, on page 1577](#)
- [Cable Monitoring Feature for Cisco cBR Series Routers , on page 1591](#)
- [Source-Based Rate Limit, on page 1599](#)
- [Cable Duplicate MAC Address Reject, on page 1623](#)
- [Cable ARP Filtering, on page 1635](#)
- [Subscriber Management Packet Filtering Extension for DOCSIS 2.0, on page 1655](#)
- [MAC Filtering, on page 1663](#)





## CHAPTER 98

# Dynamic Shared Secret

This document describes the Dynamic Shared Secret feature, which enables service providers to provide higher levels of security for their Data-over-Cable Service Interface Specifications (DOCSIS) cable networks. This feature uses randomized, single-use shared secrets to verify the DOCSIS configuration files that are downloaded to each cable modem.

The Dynamic Shared Secret feature automatically creates a unique DOCSIS shared secret on a per-modem basis, creating a one-time use DOCSIS configuration file that is valid only for the current session. This ensures that a DOCSIS configuration file that has been downloaded for one cable modem can never be used by any other modem, nor can the same modem reuse this configuration file at a later time.

This patented feature is designed to guarantee that all registered modems use only the quality of service (QoS) parameters that have been specified by the DOCSIS provisioning system for a particular modem at the time of its registration. This feature is an accepted DOCSIS standard.

Your software release may not support all the features that are documented in this module. For the latest feature information and caveats, see the release notes for your platform and software release. The Feature Information Table at the end of this document provides information about the documented features and lists the releases in which each feature is supported.

Use Cisco Feature Navigator to find information about platform support and Cisco software image support. To access Cisco Feature Navigator, go to <http://tools.cisco.com/ITDIT/CFN/>. An account on <http://www.cisco.com/> is not required.

### Contents

- [Hardware Compatibility Matrix for the Cisco cBR Series Routers, on page 1552](#)
- [Prerequisites for Dynamic Shared Secret, on page 1553](#)
- [Restrictions for Dynamic Shared Secret, on page 1553](#)
- [Information About Dynamic Shared Secret, on page 1557](#)
- [How to Configure the Dynamic Shared Secret Feature, on page 1563](#)
- [How to Monitor the Dynamic Shared Secret Feature, on page 1569](#)
- [Troubleshooting Cable Modems with Dynamic Shared Secret, on page 1572](#)
- [Configuration Examples for Dynamic Shared Secret, on page 1573](#)
- [Additional References, on page 1575](#)
- [Feature Information for Dynamic Shared Secret, on page 1576](#)

# Hardware Compatibility Matrix for the Cisco cBR Series Routers



**Note** The hardware components that are introduced in a given Cisco IOS-XE Release are supported in all subsequent releases unless otherwise specified.

**Table 311: Hardware Compatibility Matrix for the Cisco cBR Series Routers**

| Cisco CMTS Platform                    | Processor Engine                                                                                                                                                                                  | Interface Cards                                                                                                                                                                                                                                                                                                                                                                                                                                                                                                                                                                                                                                                                                                                                                                                 |
|----------------------------------------|---------------------------------------------------------------------------------------------------------------------------------------------------------------------------------------------------|-------------------------------------------------------------------------------------------------------------------------------------------------------------------------------------------------------------------------------------------------------------------------------------------------------------------------------------------------------------------------------------------------------------------------------------------------------------------------------------------------------------------------------------------------------------------------------------------------------------------------------------------------------------------------------------------------------------------------------------------------------------------------------------------------|
| Cisco cBR-8 Converged Broadband Router | <p><b>Cisco IOS-XE Release 16.5.1 and Later Releases</b></p> <p>Cisco cBR-8 Supervisor:</p> <ul style="list-style-type: none"> <li>• PID—CBR-SUP-250G</li> <li>• PID—CBR-CCAP-SUP-160G</li> </ul> | <p><b>Cisco IOS-XE Release 16.5.1 and Later Releases</b></p> <p>Cisco cBR-8 CCAP Line Cards:</p> <ul style="list-style-type: none"> <li>• PID—CBR-LC-8D30-16U30</li> <li>• PID—CBR-LC-8D31-16U30</li> <li>• PID—CBR-RF-PIC</li> <li>• PID—CBR-RF-PROT-PIC</li> <li>• PID—CBR-CCAP-LC-40G</li> <li>• PID—CBR-CCAP-LC-40G-R</li> <li>• PID—CBR-CCAP-LC-G2-R</li> <li>• PID—CBR-SUP-8X10G-PIC</li> <li>• PID—CBR-2X100G-PIC</li> </ul> <p>Digital PICs:</p> <ul style="list-style-type: none"> <li>• PID—CBR-DPIC-8X10G</li> <li>• PID—CBR-DPIC-2X100G</li> </ul> <p>Cisco cBR-8 Downstream PHY Module:</p> <ul style="list-style-type: none"> <li>• PID—CBR-D31-DS-MOD</li> </ul> <p>Cisco cBR-8 Upstream PHY Modules:</p> <ul style="list-style-type: none"> <li>• PID—CBR-D31-US-MOD</li> </ul> |



---

**Note** Do not use DPICs (8X10G and 2x100G) to forward IP traffic, as it may cause buffer exhaustion, leading to line card reload.

The only allowed traffic on a DPIC interface is DEPI, UEPI, and GCP traffic from the Cisco cBR-8 router to Remote PHY devices. Other traffic such as DHCP, SSH, and UTSC should flow via another router, since DPICs cannot be used for normal routing.

---

## Prerequisites for Dynamic Shared Secret

The configuration of Dynamic Shared Secret feature is supported on the Cisco CMTS routers.

Following is a list of other important prerequisites for the Dynamic Shared Secret feature:

- The Cisco CMTS must be running Cisco IOS-XE 3.15.0S or later.
- The Dynamic Shared Secret feature supports an external provisioning server.
- A cable modem must be able to register with the Cisco CMTS before enabling the Dynamic Shared Secret feature.
- For full security, DOCSIS configuration files should have filenames that are at least 5 or more characters in length.
- For best performance during the provisioning of cable modems, we recommend using Cisco Network Registrar Release 3.5 or later.



---

**Note** When the Dynamic Shared Secret feature is enabled using its default configuration, a cable modem diagnostic webpage shows a scrambled name for its DOCSIS configuration file. This filename changes randomly each time that the cable modem registers with the CMTS. To change the default behavior, use the **nocrypt** option with the **cable dynamic-secret** command.

---

## Restrictions for Dynamic Shared Secret

### General Restrictions for Dynamic Shared Secret

- Shared-secret and secondary-shared-secret cannot be configured with Dynamic Shared Secret feature.
- If you configure the Dynamic Shared Secret feature on a primary cable interface, you should also configure the feature on all of the corresponding subordinate cable interfaces.
- The Dynamic Shared Secret feature ensures that each cable modem registering with the CMTS can use only the DOCSIS configuration file that is specified by the service provider's authorized Dynamic Host Configuration Protocol (DHCP) and TFTP servers, using the DOCSIS-specified procedures.

- The Dynamic Shared Secret feature does not affect cable modems that are already online and provisioned. If a cable modem is online, you must reset it, so that it reregisters, before it complies with the Dynamic Shared Secret feature.
- The DMIC lock mode uses the following behavior during a switchover event in HCCP N+1 Redundancy. All cable modems which were previously in lock mode are taken offline during a switchover event, and the prior state of locked modems is lost. If previously locked modems remain non-compliant, they will return to LOCK mode after three failed registration attempts. If the modems have become DOCSIS compliant, they will return online in the normal fashion. Refer to the [SNMP Support, on page 1560](#) for additional information about DMIC lock mode.
- If a Broadband Access Center for Cable (BACC) provisioning server is being used, the Device Provisioning Engine (DPE) TFTP server verifies that the IP address of the TFTP client matches the expected DOCSIS cable modem IP Address. If a match is not found, the request is dropped. This functionality is incompatible with the CMTS DMIC feature. Use the `no tftp verify-ip` command on all BACC DPE servers to disable the verification of the requestor IP address on dynamic configuration TFTP requests. Refer to the Cisco Broadband Access Centre DPE CLI Reference in the [http://www.cisco.com/c/en/us/td/docs/net\\_mgmt/broadband\\_access\\_center\\_for\\_cable/4-0/command/reference/DPECLIRef40.html](http://www.cisco.com/c/en/us/td/docs/net_mgmt/broadband_access_center_for_cable/4-0/command/reference/DPECLIRef40.html) for additional information.

## Cable Modem Restrictions for Dynamic Shared Secret

### DHCP Restriction for Incognito Server and Thomson Cable Modems

The Dynamic Host Configuration Protocol (DHCP) passes configuration information to DHCP hosts on a TCP/IP network. Configuration parameters and other control information are stored in the options field of the DHCP message.

When using DMIC with the Incognito DHCP server, the Incognito server must be re-configured so that the following two options are *not* sent in the DHCP message:

- *option 66*—This option is used to identify a TFTP server when the `sname` field in the DHCP header has been used for DHCP options. Option 66 is a variable-length field in the Options field of a DHCP message described as "an option used to identify a TFTP server when the 'sname' field in the DHCP header has been used for DHCP options" as per RFC 2132.
- *sname field*—The `sname` field is a 64-octet field in the header of a DHCP message described as "optional server host name, null terminated string," as per RFC2131. A DHCP server inserts this option if the returned parameters exceed the usual space allotted for options. If this option is present, the client interprets the specified additional fields after it concludes interpretation of the standard option fields.



---

**Note** It is not compliant with DOCSIS to include both of these options in the DHCP message.

---

The problematic packet capture below is a DHCP offer in which both `sname` and option 66 are set (in this respective sequence):

```
0000 00 30 19 47 8f 00 00 d0 b7 aa 95 50 08 00 45 00
0010 01 4a 8f 50 00 00 80 11 46 30 ac 10 02 01 ac 10
0020 0a 01 00 43 00 43 01 36 0c 75 02 01 06 00 b0 a0
0030 25 01 00 00 00 00 00 00 00 00 00 00 ac 10 0a 53 00 00
0040 00 00 ac 10 0a 01 00 10 95 25 a0 b0 00 00 00 00
```

```

0050 00 00 00 00 00 00 5b 31 37 32 2e 31 36 2e 32 2e
(sname option immediately above)
0060 31 5d 00 00 00 00 00 00 00 00 00 00 00 00 00 00
0070 00 00 00 00 00 00 00 00 00 00 00 00 00 00 00 00
0080 00 00 00 00 00 00 00 00 00 00 00 00 00 00 00 00
0090 00 00 00 00 00 00 64 65 66 61 75 6c 74 2e 63 66
00a0 67 00 00 00 00 00 00 00 00 00 00 00 00 00 00 00
00b0 00 00 00 00 00 00 00 00 00 00 00 00 00 00 00 00
00c0 00 00 00 00 00 00 00 00 00 00 00 00 00 00 00 00
00d0 00 00 00 00 00 00 00 00 00 00 00 00 00 00 00 00
00e0 00 00 00 00 00 00 00 00 00 00 00 00 00 00 00 00
00f0 00 00 00 00 00 00 00 00 00 00 00 00 00 00 00 00
0100 00 00 00 00 00 00 00 00 00 00 00 00 00 00 00 00
0110 00 00 00 00 00 00 63 82 53 63 35 01 02 36 04 ac
0120 10 02 01 33 04 00 06 94 0d 01 04 ff ff ff 00 02
0130 04 ff ff b9 b0 03 08 ac 10 02 fe ac 10 0a 01 04
0140 04 ac 10 02 01 07 04 ac 10 02 01 42 0a 31 37 32
(option 66 immediately above)
0150 2e 31 36 2e 32 2e 31 ff

```

When using DMIC with Incognito DHCP servers and Thomson cable modems, you must prevent both options from being sent in the DHCP offer. Use one of the following workaround methods to achieve this:

- Change the Incognito DHCP server so that it does not include the sname option as described above.
- Change the cable modem code so that sname is not prioritized above option 66, as in the problematic packet capture shown in the example above.
- Migrate to a compliant DHCP and TFTP server such as CNR. This also offers significantly higher performance.

Refer to these resources for additional DOCSIS DHCP information, or optional DHCP MAC exclusion:

- *DHCP Options and BOOTP Vendor Extensions, RFC 2132*

<http://www.ietf.org/rfc/rfc2132.txt>

- *Filtering Cable DHCP Lease Queries on Cisco CMTS Routers*

<http://www.cisco.com/en/US/docs/cable/cmmts/feature/cblsrcvy.html>

## DOCSIS Compliance

- Cable modems are assumed to be DOCSIS-compliant. If a cable modem is not fully DOCSIS-compliant, it could trigger a CMTS Message Integrity Check (MIC) failure during registration in rare circumstances. Under normal operations, however, it can be assumed that cable modems that fail the CMTS MIC check from the Dynamic Shared Secret feature are either not DOCSIS-compliant, or they might have been hacked by the end user to circumvent DOCSIS security features.

Some of the cable modems with the following OUIs have been identified as having problems with the Dynamic Shared Secret feature, depending on the hardware and software revisions:

- 00.01.03
- 00.E0.6F
- 00.02.B2

These particular cable modems can remain stuck in the init(o) MAC state and cannot come online until the Dynamic Shared Secret feature is disabled. If this problem occurs, Cisco recommends upgrading the cable modem's software to a fully compliant software revision.

Alternatively, these cable modems may be excluded from the *dynamic* secret function using the following command in global configuration mode:

#### **cable dynamic-secret exclude**

Excluding cable modems means that if a violator chooses to modify their cable modem to use one of the excluded OUIs, then the system is no longer protected. Refer to the [#unique\\_1924](#).



**Tip** To help providers to identify non-DOCSIS compliant modems in their network, the Dynamic Shared Secret feature supports a “mark-only” option. When operating in the mark-only mode, cable modems might be able to successfully obtain higher classes of service than are provisioned, but these cable modems will be marked as miscreant in the **show cable modem** displays (with **!online**, for example). Such cable modems also display with the **show cable modem rogue** command. Service providers may decide whether those cable modems must be upgraded to DOCSIS-compliant software, or whether the end users have hacked the cable modems for a theft-of-service attack.

The following example illustrates output from a Cisco CMTS that is configured with the **cable dynamic-secret mark** command with miscreant cable modems installed. These cable modems may briefly show up as “reject(m)” for up to three registration cycles before achieving the **!online** status.

```
Router# show cable modem rogue
MAC Address      Vendor      Interface  Spoofer TFTP
Count Dnld Dynamic Secret
000f.0000.0133  00.0F.00   C4/0/U1    3      Yes   905B740F906B48870B3A9C5E441CDC67
000f.0000.0130  00.0F.00   C4/0/U1    3      Yes   051AEA93062A984F55E7AAC979D10901
000f.0000.0132  00.0F.00   C4/0/U2    3      Yes   FEDC1A6DA5C92B17B23AFD2BBFBAD9E1
vxr#scm | inc 000f
000f.0000.0133  4.174.4.101 C4/0/U1    !online 1      -7.00 2816 0  N
000f.0000.0130  4.174.4.89  C4/0/U1    !online 2      -6.50 2819 0  N
000f.0000.0132  4.174.4.90  C4/0/U2    !online 18     -7.00 2819 0  N
```

## TFTP Restrictions

- Cable modems can become stuck in the TFTP transfer state (this is indicated as `init(o)` by the **show cable modem** command) in the following situation:
  - The Dynamic Shared Secret feature is enabled on the cable interface, using the **cable dynamic-secret** command. This feature applies if the cable modem is a miscreant cable modem, or if the cable modem is a DOCSIS 1.0 cable modem running early DOCSIS 1.0 firmware that has not yet been updated. This feature also applies if the TFTP server is unable to provide the cable modem's TFTP configuration file to the Cisco CMTS. This is the case, for example, when using BACC and not configuring the system to permit a TFTP request from a non-matching source IP address. The **debug cable dynamic-secret** command also shows this failure.
  - A large number of cable modems are registering at the same time. Some or all of those cable modems could also be downloading the DOCSIS configuration file using multiple TFTP transfers that use multiple TFTP ports on the Cisco CMTS router, and the TFTP server is unable to keep up with the rate of TFTP requests generated by the system. Some TFTP servers may be limited to the number of concurrent TFTP get requests initiated by the same source IP address per unit time, or simply unable to handle the rate of new modem registrations before cable dynamic-secret is configured. The **debug cable dynamic-secret** command shows failure to receive some files in this situation.

This situation of stuck cable modems can result in the TFTP server running out of available ports, resulting in the cable modems failing the TFTP download stage. To prevent this situation from happening, temporarily



disable the Dynamic Shared Secret feature on the cable interface or reduce the size of the DOCSIS configuration file.

## Information About Dynamic Shared Secret

The DOCSIS specifications require that cable modems download, from an authorized TFTP server, a DOCSIS configuration file that specifies the quality of service (QoS) and other parameters for the network session. Theft-of-service attempts frequently attempt to intercept, modify, or substitute the authorized DOCSIS configuration file, or to download the file from a local TFTP server.

To prevent theft-of-service attempts, the DOCSIS specification allows service providers to use a shared secret password to calculate the CMTS Message Integrity Check (MIC) field that is attached to all DOCSIS configuration files. The CMTS MIC is an MD5 digest that is calculated over the DOCSIS Type/Length/Value (TLV) fields that are specified in the configuration file, and if a shared secret is being used, it is used in the MD5 calculation as well.

The cable modem must include its calculation of the CMTS MIC in its registration request, along with the contents of the DOCSIS configuration file. If a user modifies any of the fields in the DOCSIS configuration file, or uses a different shared secret value, the CMTS cannot verify the CMTS MIC when the cable modem registers. The CMTS does not allow the cable modem to register, and marks it as being in the “reject(m)” state to indicate a CMTS MIC failure.

Users, however, have used various techniques to circumvent these security checks, so that they can obtain configuration files that provide premium services, and then to use those files to provide themselves with higher classes of services. Service providers have responded by changing the shared secret, implementing DOCSIS time stamps, and using modem-specific configuration files, but this has meant creating DOCSIS configuration files for every cable modem on the network. Plus, these responses would have to be repeated whenever a shared secret has been discovered.

The Dynamic Shared Secret feature prevents these types of attacks by implementing a dynamically generated shared secret that is unique for each cable modem on the network. In addition, the dynamic shared secrets are valid only for the current session and cannot be reused, which removes the threat of “replay attacks,” as well as the reuse of modified and substituted DOCSIS configuration files.

## Modes of Operation

The Dynamic Shared Secret feature can operate in three different modes, depending on what action should be taken for cable modems that fail the CMTS MIC verification check:

- **Marking Mode**—When using the **mark** option, the CMTS allows cable modems to come online even if they fail the CMTS MIC validity check. However, the CMTS also prints a warning message on the console and marks the cable modem in the **show cable modem** command with an exclamation point (!), so that this situation can be investigated.
- **Locking Mode**—When the **lock** option is used, the CMTS assigns a restrictive QoS configuration to CMs that fail the MIC validity check twice in a row. You can specify a particular QoS profile to be used for locked cable modems, or the CMTS defaults to special QoS profile that limits the downstream and upstream service flows to a maximum rate of 10 kbps.

If a customer resets their CM, the CM will reregister but still uses the restricted QoS profile. A locked CM continues with the restricted QoS profile until it goes offline and remains offline for at least 24 hours, at which point it is allowed to reregister with a valid DOCSIS configuration file. A system operator can manually clear the lock on a CM by using the **clear cable modem lock** command.

This option frustrates users who are repeatedly registering with the CMTS in an attempt to guess the shared secret, or to determine the details of the Dynamic Shared Secret security system.

- **Reject Mode**—In the reject mode, the CMTS refuses to allow CMs to come online if they fail the CMTS MIC validity check. These cable modems are identified in the **show cable modem** displays with a MAC state of “reject(m)” (bad MIC value). After a short timeout period, the CM attempts to reregister with the CMTS. The CM must register with a valid DOCSIS configuration file before being allowed to come online. When it does come online, the CMTS also prints a warning message on the console and marks the cable modem in the **show cable modem** command with an exclamation point (!), so that this situation can be investigated.



---

**Note** To account for possible network problems, such as loss of packets and congestion, the Cisco CMTS will allow a cable modem to attempt to register twice before marking it as having failed the Dynamic Shared Secret authentication checks.

---

## Operation of the Dynamic Shared Secret

The Dynamic Shared Secret feature automatically creates a unique DOCSIS shared secret on a per-modem basis, creating a one-time use DOCSIS configuration file that is valid only for the current session. This ensures that a DOCSIS configuration file that has been downloaded for one cable modem can never be used by any other modem, nor can the same modem reuse this configuration file at a later time.

This patent pending feature is designed to guarantee that all registered modems are using only the QOS parameters that have been specified by the DOCSIS provisioning system for that particular modem at the time of its registration.

When a DOCSIS-compliant cable modem registers with the CMTS, it sends a DHCP request, and the DHCP server sends a DHCP response that contains the name of the DOCSIS configuration file that the cable modem should download from the specified TFTP server. The cable modem downloads the DOCSIS configuration file and uses its parameters to register with the CMTS

When the Dynamic Shared Secret feature is enabled, the CMTS performs the following when it receives the DHCP messages:

- The CMTS creates a dynamically generated shared secret.
- In the default configuration, the CMTS takes the name of the DOCSIS configuration file and generates a new, randomized filename. This randomized filename changes every time the cable modem registers, which prevents the caching of DOCSIS configuration files by cable modems that are only semi-compliant with the DOCSIS specifications. You can disable this randomization of the filename by using the **nocrypt** option with the **cable dynamic-secret** command.
- The CMTS changes the IP address of the TFTP server that the cable modem should use to the IP address of the CMTS. This informs the cable modem that it should download its configuration file from the CMTS.
- The CMTS downloads the original DOCSIS configuration file from the originally specified TFTP server so that it can modify the file to use the newly generated dynamic secret.

When the cable modem downloads the DOCSIS configuration file, it receives the modified file from the CMTS. Because this file uses the one-time-use dynamically generated shared secret, the CMTS can verify that the cable modem is using this configuration file when it attempts to register with the CMTS.



---

**Note** The Dynamic Shared Secret feature does not support and is incompatible with, the use of the original shared secret or secondary shared secrets that are configured using the **cable shared-secondary-secret** and **cable shared-secret** commands.

---



---

**Tip** Although a user could attempt to circumvent these checks by downloading a DOCSIS configuration file from a local TFTP server, the cable modem would still fail the CMTS MIC verification.

---

## Interaction with Different Commands

The Dynamic Shared Secret feature works together with a number of other commands to ensure network security and integrity:

- **cable shared-secret**—The DOCSIS specification allows service providers to use a shared-secret to ensure that cable modems are using only authorized DOCSIS configuration files.

The Dynamic Shared Secret feature is incompatible with **cable shared-secret**. Do not configure the **cable shared-secret** command when using the Dynamic Shared Secret feature

- **cable shared-secondary-secret**— The Dynamic Shared Secret feature is incompatible with **cable shared-secret**. Do not configure the **cable secondary-shared-secret** command when using the Dynamic Shared Secret feature

## Performance Information

The Dynamic Shared Secret feature does not add any additional steps to the cable modem registration process, nor does it add any additional requirements to the current provisioning systems. This feature can have either a small negative or a small positive effect on the performance of the network provisioning system, depending on the following factors:

- The provisioning system (DHCP and TFTP servers) being used
- The number of cable modems that are coming online
- The vendor and software versions of the cable modems
- The number and size of the DOCSIS configuration files

Large-scale testing has shown that the Dynamic Shared Secret feature can affect the time it takes for cable modems to come online from 5% slower to 10% faster. The most significant factor in the performance of the provisioning process is the provisioning system itself. For this reason, Cisco recommends using Cisco Network Registrar (CNR) Release 3.5 or greater, which can provide significant performance improvements over generic DHCP and TFTP servers.

The second-most important factor in the performance of cable modem provisioning is the number and size of the DOCSIS configuration files. The size of the configuration file determines how long it takes to transmit the file to the cable modem, while the number of configuration files can impact how efficiently the system keeps the files in its internal cache, allowing it to reuse identical configuration files for multiple modems.

## SNMP Support

Cisco IOS-XE 3.15.0S and later releases add the following SNMP support for the Dynamic Shared Secret feature:

- Adds the following MIB objects to the CISCO-DOCS-EXT-MIB:
  - `cdxCmtsCmDMICMode`—Sets and shows the configuration of the Dynamic Shared Secret feature for a specific cable modem (not configured, mark, lock, or reject).
  - `cdxCmtsCmDMICLockQoS`—Specifies the restrictive QoS profile assigned to a cable modem that has failed the Dynamic Shared Secret security checks, when the interface has been configured for lock mode.
  - `cdxCmtsCmStatusDMICTable`—Lists all cable modems that have failed the Dynamic Shared Secret security checks.
- An SNMP trap (`cdxCmtsCmDMICLockNotification`) can be sent when a cable modem is locked for failing the Dynamic Shared Secret security checks. The trap can be enabled using the **`snmp-server enable traps cable dmic-lock`** command.



**Note** The DMIC lock mode is disabled during a switchover event in HCCP N+1 Redundancy.

## System Error Messages

The following system error messages provide information about cable modems that have failed the CMTS Message Integrity Check (MIC) when the Dynamic Shared Secret feature is enabled.

### Message

```
%CBR-4-CMLOCKED
```

The cable modem's DOCSIS configuration file did not contain a Message Integrity Check (MIC) value that corresponds with the proper Dynamic Shared Secret that was used to encode it. The CMTS has, therefore, assigned a restrictive quality of service (QoS) configuration to this cable modem to limit its access to the network. The CMTS has also locked the cable modem so that it will remain locked in the restricted QoS configuration until it goes offline for at least 24 hours, at which point it is permitted to reregister and obtain normal service (assuming it is DOCSIS-compliant and using a valid DOCSIS configuration file).

This error message appears when the **`cable dynamic-secret lock`** command has been applied to a cable interface to enable the Dynamic Shared Secret feature for the DOCSIS configuration files on that cable interface. The cable modem has been allowed to register and come online, but with a QoS configuration that is limited to a maximum rate of 10 kbps for both the upstream and downstream flows. Check to ensure that this cable modem is not running old software that caches the previously used configuration file. Also check for a possible theft-of-service attempt by a user attempting to download a modified DOCSIS configuration file from a local TFTP server. The CM cannot reregister with a different QoS profile until it has been offline for 24 hours, without attempting to register, or you have manually cleared the lock using the **`clear cable modem lock`** command.

### Message

```
%CBR-4-CMMARKED
```

The cable modem's DOCSIS configuration file did not contain a Message Integrity Check (MIC) value that corresponds with the proper dynamic shared secret that was used to encode it. The CMTS has allowed this modem to register and come online, but has marked it in the **show cable modem** displays with an exclamation point (!) so that the situation can be investigated.

This error message appears when the **cable dynamic-secret mark** command has been applied to a cable interface to enable the Dynamic Shared Secret feature for the DOCSIS configuration files on that cable interface. Check to ensure that this cable modem is not running old software that caches the previously used configuration file. Also check for a possible theft-of-service attempt by a user attempting to download a modified DOCSIS configuration file from a local TFTP server.

### Message

```
%CBR-4-NOCFGFILE
```

The CMTS could not obtain the DOCSIS configuration file for this cable modem from the TFTP server. This message occurs when the Dynamic Shared Secret feature is enabled on the cable interface with the **cable dynamic-secret** command.

Verify that the CMTS has network connectivity with the TFTP server, and that the specified DOCSIS configuration file is available on the TFTP server. Check that the DHCP server is correctly configured to send the proper configuration filename in its DHCP response to the cable modem. Also verify that the DOCSIS configuration file is correctly formatted.

This problem could also occur if the TFTP server is offline or is overloaded to the point where it cannot respond promptly to new requests. It might also be seen if the interface between the CMTS and TFTP server is not correctly configured and flaps excessively.



---

**Note** This error indicates a problem with the provisioning system outside of the Cisco CMTS. Disabling the Dynamic Shared Secret feature does not clear the fault, nor does it allow cable modems to come online. You must first correct the problem with the provisioning system.

---

## Benefits

The Dynamic Shared Secret feature provides the following benefits to cable service providers and their partners and customers:

### Improves Network Security

Service providers do not need to worry about users discovering the shared secret value and using it to modify DOCSIS configuration files to give themselves higher levels of service. Even if a user were to discover the value of a dynamically generated shared secret, the user would not be able to use that shared secret again to register.

The generic TFTP server performance and error handling on the Cisco CMTS routers has been greatly improved to support the high performance that is required for rapidly provisioning cable modems.

### Flexibility in Dealing with Possible Theft-of-Service Attempts

Service providers have the option of deciding what response to take when a DOCSIS configuration file fails its CMTS MIC check: mark that cable modem and allow the user online, reject the registration request and

refuse to allow the user to come online until a valid DOCSIS configuration file is used, or lock the cable modem in a restricted QoS configuration until the modem remains offline for 24 hours. Locking malicious modems is the most effective deterrent against hackers, because it provides the maximum penalty and minimum reward for any user attempting a theft-of-service attack.

### No Changes to Provisioning System Are Needed

Service providers can use the Dynamic Shared Secret feature without changing their provisioning or authentication systems. Existing DOCSIS configuration files can be used unchanged, and you do not need to change any existing shared secrets.



---

**Tip** If not already done, the service provider could also install access controls that allow only the CMTS routers to download DOCSIS configuration files from the TFTP servers.

---

### No Changes to Cable Modems Are Needed

The Dynamic Shared Secret feature does not require any end-user changes or any changes to the cable modem configuration. This feature supports any DOCSIS compliant cable modem.



---

**Note** The Dynamic Shared Secret feature does not affect cable modems that are already online and provisioned. Cable modems that are already online when the feature is enabled or disabled remain online.

---

### Simplifies Network Management

Service providers do not have to continually update the shared secrets on a cable interface whenever the files providing premium services become widely available. Instead, providers can use the same shared secret on a cable interface for significant periods of time, trusting in the Dynamic Shared Secret feature to provide unique, single-use shared secrets for each cable modem.

In addition, service providers do not have to manage unique DOCSIS configuration files for each cable modem. The same configuration file can be used for all users in the same service class, without affecting network security.

## Related Features

The following features can be used with the Dynamic Shared Secret feature to enhance the overall security of the cable network.

- **Baseline Privacy Interface Plus (BPI+) Authorization and Encryption**—Provides a secure link between the cable modem and CMTS, preventing users from intercepting or modifying packets that are transmitted over the cable interface. BPI+ also provides for secure authorization of cable modems, using X.509 digital certificates, as well as a secure software download capability that ensures that software upgrades are not spoofed, intercepted, or altered.

# How to Configure the Dynamic Shared Secret Feature

The following sections describe how to enable and configure the Dynamic Shared Secret feature, to disable the feature, to manually clear a lock on a cable modem, or dynamically upgrade firmware on the cable modems.



---

**Note** All procedures begin and end at the privileged EXEC prompt (“Router#”).

---

## Enabling and Configuring the Dynamic Shared Secret Feature

This section describes how to enable and configure the Dynamic Shared Secret feature on a cable interface.

---

### Step 1 **configure terminal**

**Example:**

```
Router# configure terminal
```

**Example:**

```
Router(config)#
```

Enters global configuration mode.

### Step 2 **cable qos permission create**

**Example:**

```
Router(config)# cable qos permission create
```

**Example:**

```
Router(config)#
```

(Optional) If you are using the **lock** option in Step 6, and if you are not specifying a specific QoS profile to be used, you must allow cable modems to create their own QoS profiles.

### Step 3 **cable qos permission update**

**Example:**

```
Router(config)# cable qos permission update
```

**Example:**

```
Router(config)#
```

(Optional) If you are using the **lock** option in Step 6, and if you are not specifying a specific QoS profile to be used, you must allow cable modems to update their own QoS profiles.

### Step 4 **snmp-server enable traps cable dmic-lock**

**Example:**

```
Router(config)# snmp-server enable traps cable dmic-lock
```

**Example:**

```
Router(config)#
```

(Optional) Enables the sending of SNMP traps when a cable modem fails a dynamic shared-secret security check.

**Step 5** `interface cable interface`**Example:**

```
Router(config)# interface cable 3/0
```

**Example:**

```
Router(config-if)#
```

Enters interface configuration mode for the specified cable interface.

**Step 6** `cable dynamic-secret {lock [lock-qos] | mark | reject} [nocrypt`**Example:**

```
Router(config-if)# cable dynamic-secret lock
```

**Example:**

```
Router(config-if)# cable dynamic-secret lock 90
```

**Example:**

```
Router(config-if)# cable dynamic-secret mark
```

**Example:**

```
Router(config-if)# cable dynamic-secret reject
```

**Example:**

```
Router(config-if)#
```

Enables the Dynamic Shared Secret feature on the cable interface and configures it for the appropriate option:

- **nocrypt**—(Optional) The Cisco CMTS does not encrypt the filenames of DOCSIS configuration files, but sends the files to CMs using their original names.
- **lock**—Cable modems that fail the MIC verification are allowed online with a restrictive QoS profile. The cable modems must remain offline for 24 hours to be able to reregister with a different QoS profile.
- *lock-qos*—(Optional) Specifies the QoS profile that should be assigned to locked cable modems. The valid range is 1 to 256, and the profile must have already been created. If not specified, locked cable modems are assigned a QoS profile that limits service flows to 10 kbps (requires Step 2 and Step 3).
- **mark**—Cable modems that fail the MIC verification are allowed online but are marked in the **show cable modem** displays so that the situation can be investigated.
- **reject**—Cable modems that fail the MIC verification are not allowed to register.



**Note** Repeat Step 5 and Step 6 for each cable interface to be configured.

**Step 7** **end**

**Example:**

```
Router(config-if) # end
```

**Example:**

```
Router#
```

Exits interface configuration mode and returns to privileged EXEC mode.

**Note** If you have enabled the optional Dynamic Message Integrity Check (DMIC), you may need to specify source address/VRF for the cable modem configuration file downloaded from CNR to cBR8. You can do this by using the following command:

```
cable dmic-src [ipv4|ipv6] <addr> [vrf <vrf-name-string>].
```

**Example:**

```
Router(config-if)# cable dmic-src ipv4 10.1.1.1 vrf vrf-name-1
```

The **dmic-src** configuration applies to bundle and sub-bundle. The **vrf** keyword is optional.

---

### What to do next



**Note** If you configure the Dynamic Shared Secret feature on any interface in a cable interface bundle, you should configure it on all interfaces in that same bundle.

---

## Disabling the Dynamic Shared Secret on a Cable Interface

This section describes how to disable the Dynamic Shared Secret feature on a cable interface. The cable modem continues to be validated against any shared secret or secondary shared secrets that have been defined on the cable interface.

**Step 1** **configure terminal**

**Example:**

```
Router# configure terminal
```

**Example:**

```
Router(config)#
```

Enters global configuration mode.

**Step 2** **interface cable** *interface*

**Example:**

```
Router(config)# interface cable 3/0
```

**Example:**

```
Router(config-if)#
```

Enters interface configuration mode for the specified cable interface.

**Step 3 no cable dynamic-secret****Example:**

```
Router(config-if)# no cable dynamic-secret
```

**Example:**

```
Router(config-if)#
```

Disables the Dynamic Shared Secret feature on the cable interface.

**Note** Repeat Step 2 and Step 3 for each cable interface to be configured.

**Step 4 end****Example:**

```
Router(config-if)# end
```

**Example:**

```
Router#
```

Exits interface configuration mode and returns to privileged EXEC mode.

## Excluding Cable Modems from the Dynamic Shared Secret Feature

This section describes how to exclude one or more cable modems from being processed by the Dynamic Shared Secret feature. The cable modem continues to be validated against any shared secret or secondary shared secrets that have been defined on the cable interface.

**Step 1 configure terminal****Example:**

```
Router# configure terminal
```

Enters global configuration mode.

**Step 2 cable dynamic-secret exclude {oui *oui-id* | modem *mac-address*}****Example:**

```
Router(config)# cable dynamic-secret exclude oui 00.01.B4
```

```
Router(config)# cable dynamic-secret exclude modem 00d0.45ba.b34b
```

Excludes one or more cable modems from being processed by the Dynamic Shared Secret security checks, on the basis of their MAC addresses or OUI values:

- **modem** *mac-address*—Specifies the hardware (MAC) address of one specific and individual cable modem to be excluded from the Dynamic Shared Secret feature. (You cannot specify a multicast MAC address.)
- **oui** *oui-id*—Specifies the organization unique identifier (OUI) of a vendor, so that a group of cable modems from this vendor are excluded from the Dynamic Shared Secret feature. The OUI should be specified as three hexadecimal bytes separated by either periods or colons.

**Note** Repeat this command for each cable modem MAC address or OUI vendor to be excluded.

### Step 3 exit

#### Example:

```
Router(config)# exit
```

Exits the interface configuration mode and returns to privileged EXEC mode.

## Clearing the Lock on One or More Cable Modems

This section describes how to manually clear the lock on one or more cable modems. This forces the cable modems to reinitialize, and the cable modems must reregister with a valid DOCSIS configuration file before being allowed online. If you do not manually clear the lock (using the **clear cable modem lock** command), the cable modem is locked in its current restricted QoS profile and cannot reregister with a different profile until it has been offline for at least 24 hours.

### Procedure

|        | Command or Action                                                                                                                                                                                                                                                                                                                                                                                           | Purpose                                                                                                                                                                                                                                                                                                                                                                                                                                                                                                                                                                                                                                                                                                                                                                                 |
|--------|-------------------------------------------------------------------------------------------------------------------------------------------------------------------------------------------------------------------------------------------------------------------------------------------------------------------------------------------------------------------------------------------------------------|-----------------------------------------------------------------------------------------------------------------------------------------------------------------------------------------------------------------------------------------------------------------------------------------------------------------------------------------------------------------------------------------------------------------------------------------------------------------------------------------------------------------------------------------------------------------------------------------------------------------------------------------------------------------------------------------------------------------------------------------------------------------------------------------|
| Step 1 | <p><b>clear cable modem</b> {<i>mac-addr</i>   <i>ip-addr</i>   <b>all</b>   <i>ouistring</i>   <b>reject</b>} <b>lock</b></p> <p><b>Example:</b></p> <pre>Router# clear cable modem 0001.0203.0405 lock</pre> <p><b>Example:</b></p> <pre>Router# clear cable modem all lock</pre> <p><b>Example:</b></p> <pre>Router# clear cable modem oui 00.00.0C lock</pre> <p><b>Example:</b></p> <pre>Router#</pre> | <p>Clears the lock for the cable modems, which can be identified as follows:</p> <ul style="list-style-type: none"> <li>• <i>mac-addr</i> —Specifies the MAC address for one particular cable modem to be cleared.</li> <li>• <i>ip-addr</i> —Specifies the IP address for one particular cable modem to be cleared.</li> <li>• <b>all</b>—Clears the locks on all locked cable modems.</li> <li>• <i>oui string</i> —Clears the locks on all cable modems with a vendor ID that matches the specified Organizational Unique Identifier (OUI) string.</li> <li>• <b>reject</b>—Clears the locks on all cable modems that are currently in the reject state (which would occur if a locked cable modem went offline and attempted to reregister before 24 hours had elapsed).</li> </ul> |

**What to do next**

**Tip** A cable modem can also be unlocked by manually deleting the cable modem from all CMTS internal databases, using the **clear cable modem delete** command.

## Upgrading Firmware on the Cable Modems

This section describes how to upgrade firmware on cable modems by dynamically inserting the correct TLV values in the DOCSIS configuration file that is downloaded by the cable modem. The DOCSIS configuration file contains the following TLV values:

- Software Upgrade Filename (TLV 9)—Specifies the filename of the firmware.
- Upgrade IPv4 TFTP Server (TLV21)—Specifies the IPv4 address of the TFTP server from where the modem downloads the DOCSIS configuration file.
- Upgrade IPv6 TFTP Server (TLV58)—Specifies the IPv6 address of the TFTP server from where the modem downloads the DOCSIS configuration file.



**Note** The TFTP server addresses are inserted only when the software upgrade filename (TLV9) is specified and when the TFTP server address (TLV21/TLV58) is either not specified or set to 0.

**Before you begin**

The Dynamic Shared Secret feature must be enabled first before you can upgrade the firmware on cable modems. See [Enabling and Configuring the Dynamic Shared Secret Feature, on page 1563](#) for more information.



**Note** The command to enable or disable the Dynamic Shared Secret feature is available at the MAC domain level. However, the command to upgrade the firmware on cable modems is available at the global level.

**Procedure**

|               | Command or Action                                                                                                                               | Purpose                               |
|---------------|-------------------------------------------------------------------------------------------------------------------------------------------------|---------------------------------------|
| <b>Step 1</b> | <p><b>configure terminal</b></p> <p><b>Example:</b></p> <pre>Router# configure terminal</pre> <p><b>Example:</b></p> <pre>Router(config)#</pre> | Enters the global configuration mode. |

|        | Command or Action                                                                                                                                | Purpose                                                                                                                                 |
|--------|--------------------------------------------------------------------------------------------------------------------------------------------------|-----------------------------------------------------------------------------------------------------------------------------------------|
| Step 2 | cable dynamic-secret tftp insert-upgrade-server<br><b>Example:</b><br><pre>Router(config)# cable dynamic-secret tftp insert-upgrade-server</pre> | Dynamically inserts the specific IPv4 or IPv6 TLV values in the DOCSIS configuration file to complete firmware upgrade on cable modems. |
| Step 3 | <b>end</b><br><b>Example:</b><br><pre>Router(config)# end</pre><br><b>Example:</b><br><pre>Router#</pre>                                         | Exits the configuration mode and returns to the privileged EXEC mode.                                                                   |

### What to do next



**Note** If you configure the Dynamic Shared Secret feature on an interface in a cable interface bundle, you should configure it on all the interfaces of that bundle.

## How to Monitor the Dynamic Shared Secret Feature

This section describes the following procedures you can use to monitor and display information about the Dynamic Shared Secret feature:

### Displaying Marked Cable Modems

When you configure a cable interface with the **cable dynamic-secret mark** command, cable modems that fail the dynamically generated CMTS MIC verification are allowed online, but are marked with an exclamation point (!) in the MAC state column in the **show cable modem** display. The exclamation point is also used to identify cable modems that were initially rejected, using the **cable dynamic-secret reject** command, but then reregistered using a valid DOCSIS configuration file.

For example, the following example shows that four cable modems are marked as having failed the CMTS MIC verification, but that they have been allowed online:

```
Router# show cable modems
```

| MAC Address    | IP Address      | I/F       | MAC State   | Prim Sid | RxPwr (db) | Timing Offset | Num CPE | BPI Enb |
|----------------|-----------------|-----------|-------------|----------|------------|---------------|---------|---------|
| 0010.9507.01db | 144.205.151.130 | C5/1/0/U5 | online (pt) | 1        | 0.25       | 938           | 1       | N       |
| 0080.37b8.e99b | 144.205.151.131 | C5/1/0/U5 | online      | 2        | -0.25      | 1268          | 0       | N       |
| 0002.fdfa.12ef | 144.205.151.232 | C6/1/0/U0 | online (pt) | 13       | -0.25      | 1920          | 1       | N       |
| 0002.fdfa.137d | 144.205.151.160 | C6/1/0/U0 | !online     | 16       | -0.50      | 1920          | 1       | N       |

## Displaying the Current Dynamic Secrets

```

0003.e38f.e9ab 144.205.151.237 C6/1/0/U0 !online      3      -0.50   1926   1     N
0003.e3a6.8173 144.205.151.179 C6/1/1/U2 offline     4       0.50   1929   0     N
0003.e3a6.8195 144.205.151.219 C6/1/1/U2 !online(pt) 22     -0.50   1929   1     N
0006.28dc.37fd 144.205.151.244 C6/1/1/U2 online(pt)  61      0.00   1925   2     N
0006.28e9.81c9 144.205.151.138 C6/1/1/U2 online(pt)  2       0.75   1925   1     N
0006.28f9.8bbd 144.205.151.134 C6/1/1/U2 online     25     -0.25   1924   1     N
0006.28f9.9d19 144.205.151.144 C6/1/1/U2 online(pt)  28      0.25   1924   1     N
0010.7bed.9b6d 144.205.151.228 C6/1/1/U2 online(pt)  59      0.25   1554   1     N
0002.fdfa.12db 144.205.151.234 C7/0/0/U0 online     15     -0.75   1914   1     N
0002.fdfa.138d 144.205.151.140 C7/0/0/U5 online      4       0.00   1917   1     N
0003.e38f.e85b 144.205.151.214 C7/0/0/U5 !online     17      0.25   1919   1     N
0003.e38f.f4cb 144.205.151.238 C7/0/0/U5 online(pt)  16      0.00   !2750  1     N
0003.e3a6.7fd9 144.205.151.151 C7/0/0/U5 online      1      0.25   1922   0     N
0020.4005.3f06 144.205.151.145 C7/0/0/U0 online(pt)  2       0.00   1901   1     N
0020.4006.b010 144.205.151.164 C7/0/0/U5 online(pt)  3       0.00   1901   1     N
0050.7302.3d83 144.205.151.240 C7/0/0/U0 online(pt)  18     -0.25   1543   1     N
00b0.6478.ae8d 144.205.151.254 C7/0/0/U5 online(pt)  44      0.25   1920  21     N
00d0.bad3.c0cd 144.205.151.149 C7/0/0/U5 online     19      0.25   1543   1     N
00d0.bad3.c0cf 144.205.151.194 C7/0/0/U0 online     13      0.00   1546   1     N
00d0.bad3.c0d5 144.205.151.133 C7/0/0/U0 online     12      0.50   1546   1     N
Router#

```

You can also use the **show cable modem rogue** command to display only those cable modems that have been rejected for failing the dynamic shared-secret authentication checks:

```

Router# show cable modem rogue
MAC Address      Vendor      Interface  Spooft  TFTP
Count Dnld Dynamic Secret
AAAA.7b43.aa7f  Vendor1    C4/0/U5    2   Yes  45494DC933F8F47A398F69EE6361B017
AAAA.7b43.aa7f  Vendor1    C4/0/U5    2   Yes  D47BCBB5494E9936D51CB0EB66EF0B0A
BBBB.7b43.aa7f  Vendor2    C4/0/U5    2   No   8EB196423170B26684BF6730C099D271
AAAA.7b43.aa7f  Vendor1    C4/0/U5    2   No   DF8FE30203010001A326302430120603
BBBB.7b43.aa7f  Vendor2    C4/0/U5    2   No   300E0603551D0F0101FF040403020106
AAAA.7b43.aa7f  Vendor1    C4/0/U5    2   Yes  820101002D1A264CE212A1BB6C1728B3
DDDD.7b43.aa7f  Vendor4    C4/0/U5    2   Yes  7935B694DCA90BC624AC92A519C214B9
AAAA.7b43.aa7f  Vendor1    C4/0/U5    2   No   3AB096D00D56ECD07D9B7AB662451CFF
Router#

```

## Displaying the Current Dynamic Secrets

In Cisco IOS XE Everest 16.5.1, the **verbose** option for the **show cable modem** command displays the dynamically generated shared secret (a 16-byte hexadecimal value) that was used in the cable modem's previous registration cycle. The display also shows if the cable modem failed the dynamic shared-secret check or did not download the DOCSIS configuration file from the TFTP server. If a cable modem is offline, its dynamic secret is shown as all zeros.

For example, the following example shows a typical display for a single cable modem that failed the dynamic shared-secret check:

```

Router# show cable modem 00c0.73ee.bbba verbose
MAC Address      : 00c0.73ee.bbba
IP Address       : 3.18.1.6
Prim Sid        : 2
QoS Profile Index : 6
Interface       : C3/0/U0
Upstream Power  : 0.00 dBmV (SNR = 26.92 dBmV)
Downstream Power : 0.00 dBmV (SNR = ----- dBmV)
Timing Offset   : 2812

```

```

Initial Timing Offset           : 2812
Received Power                 : 0.00
MAC Version                    : DOC1.0
Provisioned Mode               : DOC1.0
Capabilities                   : {Frag=N, Concat=N, PHS=N, Priv=BPI}
Sid/Said Limit                 : {Max Us Sids=0, Max Ds Sids=0}
Optional Filtering Support     : {802.1P=N, 802.1Q=N}
Transmit Equalizer Support     : {Taps/Symbol= 0, Num of Taps= 0}
Number of CPE IPs              : 0(Max CPE IPs = 1)
CFG Max-CPE                    : 1
Flaps                          : 26(Feb 14 02:35:39)
Errors                         : 0 CRCs, 0 HCSes
Stn Mtn Failures               : 6 aborts, 0 exhausted
Total US Flows                 : 1(1 active)
Total DS Flows                 : 1(1 active)
Total US Data                  : 0 packets, 0 bytes
Total US Throughput            : 0 bits/sec, 0 packets/sec
Total DS Data                  : 0 packets, 0 bytes
Total DS Throughput            : 0 bits/sec, 0 packets/sec
Active Classifiers              : 0 (Max = NO LIMIT)
Dynamic Secret                  : A3D1028F36EBD54FDCC2F74719664D3F
Router#

```

The following example shows a typical display for a single cable modem that is currently offline (the Dynamic Secret field shows all zeros):

```

Router# show cable modem 00C0.6914.8601 verbose

MAC Address                    : 00C0.6914.8601
IP Address                     : 10.212.192.119
Prim Sid                       : 6231
QoS Profile Index              : 2
Interface                      : C5/1/0/U3
Upstream Power                 : 0.00 dBmV (SNR = 30.19 dBmV)
Downstream Power               : 0.00 dBmV (SNR = ----- dBmV)
Timing Offset                  : 1831
Initial Timing Offset          : 1831
Received Power                 : !-2.25
MAC Version                    : DOC1.0
Provisioned Mode               : DOC1.0
Capabilities                   : {Frag=N, Concat=Y, PHS=N, Priv=BPI}
Sid/Said Limit                 : {Max Us Sids=0, Max Ds Sids=0}
Optional Filtering Support     : {802.1P=N, 802.1Q=N}
Transmit Equalizer Support     : {Taps/Symbol= 0, Num of Taps= 0}
Number of CPE IPs              : 4(Max CPE IPs = 4)
CFG Max-CPE                    : 4
Flaps                          : 20638(Feb 10 16:04:10)
Errors                         : 0 CRCs, 0 HCSes
Stn Mtn Failures               : 108 aborts, 161 exhausted
Total US Flows                 : 1(1 active)
Total DS Flows                 : 1(1 active)
Total US Data                  : 236222 packets, 146630868 bytes
Total US Throughput            : 0 bits/sec, 0 packets/sec
Total DS Data                  : 9 packets, 1114 bytes
Total DS Throughput            : 0 bits/sec, 0 packets/sec
Active Classifiers              : 0 (Max = NO LIMIT)
Dynamic Secret                  : 00000000000000000000000000000000
Router#

```



**Note** The Dynamic Secret field shown above is all zeros (“00000000000000000000000000000000”), which indicates that this cable modem is offline.

You can also use the following command to display all the dynamically generated shared secrets that are in use:

```
Router# show cable modem verbose | include Dynamic Secret

Dynamic Secret          : 43433036434644344643303841313237
Dynamic Secret          : 308203E0308202C8A003020102021058
Dynamic Secret          : 0D06092A864886F70D01010505003081
Dynamic Secret          : 3037060355040A133044617461204F76
Dynamic Secret          : 20496E74657266616365205370656369
Dynamic Secret          : 00000000000000000000000000000000
Dynamic Secret          : 040B130C4361626C65204D6F64656D73
Dynamic Secret          : 53204361626C65204D6F64656D20526F
Dynamic Secret          : 7574686F72697479301E170D30313032
Dynamic Secret          : 313233353935395A308197310B300906
Dynamic Secret          : 0A133044617461204F76657220436162
Dynamic Secret          : 66616365205370656369666963617469
Dynamic Secret          : 626C65204D6F64656D73313630340603
Dynamic Secret          : 65204D6F64656D20526F6F7420436572
Dynamic Secret          : 747930820122300D06092A864886F70D
Dynamic Secret          : 010100C0EF369D7BDAB0A938E6ED29C3
Dynamic Secret          : DA398BF619A11B3C0F64912D133CFFB6
Dynamic Secret          : FFAD6CE01590ABF5A1A0F50AC05221F2
Dynamic Secret          : 73504BCA8278D41CAD50D9849B56552D
Dynamic Secret          : 05F4655F2981E031EB76C90F9B3100D1
Dynamic Secret          : F4CB0BF4A13EA9512FDE4A2A219C27E9
Dynamic Secret          : D47BCBB5494E9936D51CB0EB66EF0B0A
Dynamic Secret          : 8EB196423170B26684BF6730C099D271
Dynamic Secret          : DF8FE30203010001A326302430120603
Dynamic Secret          : 300E0603551D0F0101FF040403020106
Dynamic Secret          : 820101002D1A264CE212A1BB6C1728B3
Dynamic Secret          : 7935B694DCA90BC624AC92A519C214B9
Dynamic Secret          : 3AB096D00D56ECD07D9B7AB662451CFF
Dynamic Secret          : 92E68CFD8783D58557E3994F23A8140F
Dynamic Secret          : 225A3B01DB67AF0C3637A765E1E7C329
Dynamic Secret          : 2BB1E6221B6D5596F3D6F506804C995E
Dynamic Secret          : 45494DC933F8F47A398F69EE6361B017
Router#
```

## Troubleshooting Cable Modems with Dynamic Shared Secret

If a cable modem is being marked as having violated the dynamic shared secret, you can enable the following debugs to get more information about the sequence of events that is occurring:

- **debug cable mac-address *cm-mac-addr* verbose**—Enables detailed debugging for the cable modem with the specific MAC address.
- **debug cable tl**—Displays the contents of Type/Length/Value messages that are sent during the registration process.
- **debug cable dynamic-secret**—Displays debugging messages about dynamic shared secret operation.



- **debug tftp server events**—Displays debugging messages for the major events that occur with the Cisco CMTS router's onboard TFTP server.
- **debug tftp server packets**—Displays a packet dump for the DOCSIS configuration files that the TFTP server downloads to a cable modem.



---

**Tip** For more information about these debug commands, see the *Cisco CMTS Debugging Commands* chapter in the Cisco Broadband Cable Command Reference Guide, at the following URL:  
[http://www.cisco.com/en/US/docs/ios/cable/command/reference/cbl\\_book.html](http://www.cisco.com/en/US/docs/ios/cable/command/reference/cbl_book.html)

---

In addition, examine the messages in the router's log buffer for any helpful information. Use the **show logging** command to display the contents of the router's logging buffer to display these messages. You can limit the output to a specific hour and minute by using the **begin** output modifier. For example, to display only those messages that were recorded at 12:10, give the following command:

```
Router# show logging | begin 12:10
```



---

**Note** The exact format for the **begin** output modifier depends on the timestamp you are using for your logging buffer.

---

## Configuration Examples for Dynamic Shared Secret

This section lists a typical configuration for the Dynamic Shared Secret feature.



---

**Note** These configurations also show a shared secret and secondary secret being configured on the cable interface. This is optional but highly recommended, because it adds an additional layer of security during the registration of cable modems.

---

### Mark Configuration: Example

The following excerpt from a configuration for the cable interface on a Cisco CMTS router configures the cable interface so that cable modems that fail the CMTS MIC check are allowed to come online, but are marked with an exclamation point (!) in the **show cable modem** displays, so that the situation can be investigated further.

```
interface cable c5/1/0
 cable dynamic-secret mark
 ...
```

## Lock Configuration: Example

The following excerpt from a configuration for the cable interface on a Cisco CMTS router configures the cable interface so that cable modems that fail the CMTS MIC check are allowed to come online, but are locked into a restrictive QoS configuration that limits the upstream and downstream service flows to a maximum rate of 10 kbps. A locked cable modem remains locked into the restrictive QoS configuration until the modem has remained offline for more than 24 hours, or until you have manually cleared it using the **clear cable modem lock** command.

```
interface cable c3/0
 cable dynamic-secret lock
 ...
```



- 
- Note**
- Configuring the **cable qos permission create** and **cable qos permission update** commands are **optional**.
  - If you use the **lock** option without specifying a specific QoS profile, you must allow cable modems to create and update QoS profiles, using the **cable qos permission modems** command. If you do not do this and continue to use the **lock** option without specifying a particular QoS profile, locked cable modems are not allowed to register until the lock clears or expires.
- 

The following example is the same except that it specifies that the locked cable modem should be assigned QoS profile 90. The cable modem remains locked with this QoS profile until the modem has remained offline for more than 24 hours, or until you have manually cleared it using the **clear cable modem lock** command. Because a specific QoS profile is specified, you do not need to use the **cable qos permission modems** command.

```
interface cable c3/0
 cable dynamic-secret lock 90
 ...
```



- 
- Note** When a locked modem is cleared, it is automatically reset so that it reregisters with the CMTS. It is allowed online with the requested QoS parameters if it registers with a valid DOCSIS configuration that passes the Dynamic Shared Secret checks. However, the modem is locked again if it violates the DOCSIS specifications again.
- 

The `show cable qos profile` command does not show the default qos profile when `dmic lock` is working. The following example shows a sample output of the `show cable qos profile` command when `dmic lock` is working.

```
Router# show cable qos profile
Load for five secs: 12%/0%; one minute: 11%; five minutes: 11%
Time source is NTP, 10:49:33.828 EDT Mon Jun 5 2023

% Warning: Use "show interface Cable x/y/z qos paramset" since it replaces
"show cable qos profile" for DOCSIS1.1 operation
ID  Prio Max      Guarantee Max      Max  TOS  TOS  Create  B      IP prec.
      upstream upstream downstream tx   AND  OR   by      priv  rate
```

```

          bandwidth bandwidth bandwidth  burst  mask mask          enab  enab
1  0  0  0  0  0  0  0xFF 0x0  cmts(r) no  no
2  0  64000  0  1000000  0  0xFF 0x0  cmts(r) no  no
3  7  31200  31200  0  0  0xFF 0x0  cmts  yes  no
4  7  87200  87200  0  0  0xFF 0x0  cmts  yes  no

```

## Reject Configuration: Example

The following excerpt from a configuration for the cable interface on a Cisco CMTS configures the cable interface so that cable modems that fail the CMTS MIC check are rejected and not allowed to register. The cable modem must reregister using a DOCSIS configuration file with a CMTS MIC that matches one of the shared secret or secondary secret values. When it does come online, the CMTS also prints a warning message on the console and marks the cable modem in the **show cable modem** command with an exclamation point (!), so that this situation can be investigated.

```

interface cable c3/0
 cable dynamic-secret reject
...

```

## Disabled Configuration: Example

The following excerpt from a configuration for the cable interface on a Cisco uBR7100 series router disables the Dynamic Shared Secret feature. In this configuration, the CMTS uses the shared secret and secondary shared secret values unchanged when verifying the CMTS MIC value for each DOCSIS configuration file.

```

interface cable c1/0
 no cable dynamic-secret
...

```

## Additional References

For additional information related to Dynamic Shared Secret, refer to the following references:

### Standards

| Standards <sup>10</sup> | Title                                                                                                 |
|-------------------------|-------------------------------------------------------------------------------------------------------|
| SP-RFIV1.1-I09-020830   | Data-over-Cable Service Interface Specifications Radio Frequency Interface Specification, version 1.1 |

<sup>10</sup> Not all supported standards are listed.

**MIBs**

| MIBs <sup>11</sup>                                                                                                                                                                                                                                                                                                    | MIBs Link                                                                                                                                                                                                                         |
|-----------------------------------------------------------------------------------------------------------------------------------------------------------------------------------------------------------------------------------------------------------------------------------------------------------------------|-----------------------------------------------------------------------------------------------------------------------------------------------------------------------------------------------------------------------------------|
| <p>No new or modified MIB objects are supported by the Dynamic Shared Secret feature.</p> <ul style="list-style-type: none"> <li>• CISCO-DOCS-EXT-MIB—Includes attributes to configure the Dynamic Shared Secret feature and to generate traps when a cable modem fails the shared-secret security checks.</li> </ul> | <p>To locate and download MIBs for selected platforms, Cisco IOS releases, and feature sets, use Cisco MIB Locator found at the following URL:</p> <p><a href="http://www.cisco.com/go/mibs">http://www.cisco.com/go/mibs</a></p> |

<sup>11</sup> Not all supported MIBs are listed.

**RFCs**

| RFCs <sup>12</sup> | Title                               |
|--------------------|-------------------------------------|
| RFC 2233           | DOCSIS OSSI Objects Support         |
| RFC 2665           | DOCSIS Ethernet MIB Objects Support |
| RFC 2669           | Cable Device MIB                    |

<sup>12</sup> Not all supported RFCs are listed.

## Feature Information for Dynamic Shared Secret

Use Cisco Feature Navigator to find information about the platform support and software image support. Cisco Feature Navigator enables you to determine which software images support a specific software release, feature set, or platform. To access Cisco Feature Navigator, go to the <https://cfngng.cisco.com/> link. An account on the Cisco.com page is not required.



**Note** The following table lists the software release in which a given feature is introduced. Unless noted otherwise, subsequent releases of that software release train also support that feature.

**Table 312: Feature Information for Downstream Interface Configuration**

| Feature Name          | Releases                    | Feature Information                                                                                              |
|-----------------------|-----------------------------|------------------------------------------------------------------------------------------------------------------|
| Dynamic shared secret | Cisco IOS XE Everest 16.6.1 | This feature was integrated into Cisco IOS XE Everest 16.6.1 on the Cisco cBR Series Converged Broadband Router. |



## CHAPTER 99

# Lawful Intercept Architecture

---

The Lawful Intercept (LI) feature supports service providers in meeting the requirements of law enforcement agencies to provide the ability to intercept Voice-over-Internet protocol (VoIP) or data traffic going through the edge routers. This document explains LI architecture, including Cisco Service Independent Intercept architecture and PacketCable Lawful Intercept architecture. It also describes the components of the LI feature and provides instructions on how to configure the LI feature in your system.

Your software release may not support all the features that are documented in this module. For the latest feature information and caveats, see the release notes for your platform and software release. The Feature Information Table at the end of this document provides information about the documented features and lists the releases in which each feature is supported.

Use Cisco Feature Navigator to find information about platform support and Cisco software image support. To access Cisco Feature Navigator, go to <http://tools.cisco.com/ITDIT/CFN/>. An account on <http://www.cisco.com/> is not required.

### Contents

- [Hardware Compatibility Matrix for the Cisco cBR Series Routers, on page 1577](#)
- [Prerequisites for Lawful Intercept, on page 1579](#)
- [Restrictions for Lawful Intercept, on page 1579](#)
- [Information About Lawful Intercept, on page 1580](#)
- [How to Configure Lawful Intercept, on page 1584](#)
- [Configuration Examples for Lawful Intercept, on page 1588](#)
- [Additional References, on page 1589](#)
- [Feature Information for Lawful Intercept, on page 1590](#)

## Hardware Compatibility Matrix for the Cisco cBR Series Routers



---

**Note** The hardware components that are introduced in a given Cisco IOS-XE Release are supported in all subsequent releases unless otherwise specified.

---

Table 313: Hardware Compatibility Matrix for the Cisco cBR Series Routers

| Cisco CMTS Platform                    | Processor Engine                                                                                                                                                                                  | Interface Cards                                                                                                                                                                                                                                                                                                                                                                                                                                                                                                                                                                                                                                                                                                                                                                                 |
|----------------------------------------|---------------------------------------------------------------------------------------------------------------------------------------------------------------------------------------------------|-------------------------------------------------------------------------------------------------------------------------------------------------------------------------------------------------------------------------------------------------------------------------------------------------------------------------------------------------------------------------------------------------------------------------------------------------------------------------------------------------------------------------------------------------------------------------------------------------------------------------------------------------------------------------------------------------------------------------------------------------------------------------------------------------|
| Cisco cBR-8 Converged Broadband Router | <p><b>Cisco IOS-XE Release 16.5.1 and Later Releases</b></p> <p>Cisco cBR-8 Supervisor:</p> <ul style="list-style-type: none"> <li>• PID—CBR-SUP-250G</li> <li>• PID—CBR-CCAP-SUP-160G</li> </ul> | <p><b>Cisco IOS-XE Release 16.5.1 and Later Releases</b></p> <p>Cisco cBR-8 CCAP Line Cards:</p> <ul style="list-style-type: none"> <li>• PID—CBR-LC-8D30-16U30</li> <li>• PID—CBR-LC-8D31-16U30</li> <li>• PID—CBR-RF-PIC</li> <li>• PID—CBR-RF-PROT-PIC</li> <li>• PID—CBR-CCAP-LC-40G</li> <li>• PID—CBR-CCAP-LC-40G-R</li> <li>• PID—CBR-CCAP-LC-G2-R</li> <li>• PID—CBR-SUP-8X10G-PIC</li> <li>• PID—CBR-2X100G-PIC</li> </ul> <p>Digital PICs:</p> <ul style="list-style-type: none"> <li>• PID—CBR-DPIC-8X10G</li> <li>• PID—CBR-DPIC-2X100G</li> </ul> <p>Cisco cBR-8 Downstream PHY Module:</p> <ul style="list-style-type: none"> <li>• PID—CBR-D31-DS-MOD</li> </ul> <p>Cisco cBR-8 Upstream PHY Modules:</p> <ul style="list-style-type: none"> <li>• PID—CBR-D31-US-MOD</li> </ul> |



**Note** Do not use DPICs (8X10G and 2x100G) to forward IP traffic, as it may cause buffer exhaustion, leading to line card reload.

The only allowed traffic on a DPIC interface is DEPI, UEPI, and GCP traffic from the Cisco cBR-8 router to Remote PHY devices. Other traffic such as DHCP, SSH, and UTSC should flow via another router, since DPICs cannot be used for normal routing.

# Prerequisites for Lawful Intercept

Access to the Cisco LI MIB view should be restricted to the mediation device and to system administrators who need to be aware of lawful intercepts on the router. To access the MIB, users must have level-15 access rights on the router.

## Communication with Mediation Device

For the router to communicate with the mediation device to execute a lawful intercept, the following configuration requirements must be met:

- The domain name for both the router and the mediation device must be registered in the Domain Name System (DNS).

In DNS, the router IP address is typically the address of the TenGigabitEthernet5/1/0 or TenGigabitEthernet4/1/0 interface (depending on the slot in which the Supervisor is installed) on the router.

- The mediation device must have an access function (AF) and an access function provisioning interface (AFPI).
- You must add the mediation device to the Simple Network Management Protocol (SNMP) user group that has access to the CISCO-TAP2-MIB view. Specify the username of the mediation device as the user to add to the group.

When you add the mediation device as a CISCO-TAP2-MIB user, you can include the mediation device's authorization password if you want. The password must be at least eight characters in length.

# Restrictions for Lawful Intercept

## General Restrictions

There is no command-line interface (CLI) available to configure LI on the router. All error messages are sent to the mediation device as SNMP notifications. All intercepts are provisioned using SNMPv3 only.

Lawful Intercept does not support SUP HA. LI configuration needs to be reapplied after SUP switchover. An SNMP trap will be generated for this event.

## Lawful Intercept MIBs

Only the mediation device and users who need to know about lawful intercepts are allowed to access the LI MIBs.

Due to its sensitive nature, the Cisco LI MIBs are only available in software images that support the LI feature. These MIBs are not accessible through the Network Management Software MIBs Support page (<http://www.cisco.com/public/sw-center/netmgmt/cmtk/mibs.shtml>).

## SNMP Notifications

SNMP notifications for LI must be sent to User Datagram Protocol (UDP) port 161 on the mediation device, not port 162 (which is the SNMP default).

# Information About Lawful Intercept

## Introduction to Lawful Intercept

LI is the process by which law enforcement agencies (LEAs) conduct electronic surveillance as authorized by judicial or administrative order. Increasingly, legislation is being adopted and regulations are being enforced that require service providers (SPs) and Internet service providers (ISPs) to implement their networks to explicitly support authorized electronic surveillance. The types of SPs or ISPs that are subject to LI mandates vary greatly from country to country. LI compliance in the United States is specified by the Commission on Accreditation for Law Enforcement Agencies (CALEA).

Cisco supports two architectures for LI: PacketCable and Service Independent Intercept. The LI components by themselves do not ensure customer compliance with applicable regulations but rather provide tools that can be used by SPs and ISPs to construct an LI-compliant network.

## Cisco Service Independent Intercept Architecture

The [Cisco Service Independent Intercept Architecture Version 3.0](#) document describes implementation of LI for VoIP networks using the Cisco BTS 10200 Softswitch call agent, version 5.0, in a non-PacketCable network. Packet Cable Event Message specification version 1.5-I01 is used to deliver the call identifying information along with version 2.0 of the Cisco Tap MIB for call content.

The [Cisco Service Independent Intercept Architecture Version 2.0](#) document describes implementation of LI for VoIP networks using the Cisco BTS 10200 Softswitch call agent, versions 4.4 and 4.5, in a non-PacketCable network. Although not a PacketCable network, PacketCable Event Messages Specification version I08 is still used to deliver call identifying information, along with version 1.0 or version 2.0 of the Cisco Tap MIB for call content. The *Cisco Service Independent Intercept Architecture Version 2.0* document adds additional functionality for doing data intercepts by both IP address and session ID, which are both supported in version 2.0 of the Cisco Tap MIB (CISCO-TAP2-MIB).

The [Cisco Service Independent Intercept Architecture Version 1.0](#) document describes implementation of LI for VoIP networks that are using the Cisco BTS 10200 Softswitch call agent, versions 3.5 and 4.1, in a non-PacketCable network. Although not a PacketCable network, PacketCable Event Message Specification version I03 is still used to deliver call identifying information, along with version 1.0 of the Cisco Tap MIB (CISCO-TAP-MIB) for call content. Simple data intercepts by IP address are also discussed.

## PacketCable Lawful Intercept Architecture

The *PacketCable Lawful Intercept Architecture for BTS Version 5.0* document describes the implementation of LI for VoIP using Cisco BTS 10200 Softswitch call agent, version 5.0, in a PacketCable network that conforms to PacketCable Event Messages Specification version 1.5-I01.

The *PacketCable Lawful Intercept Architecture for BTS Versions 4.4 and 4.5* document describes the implementation of LI for VoIP using Cisco BTS 10200 Softswitch call agent, versions 4.4 and 4.5, in a PacketCable network that conforms to PacketCable Event Messages Specification version I08.

The [PacketCable Lawful Intercept Architecture for BTS Versions 3.5 and 4.1](#) document describes the implementation of LI for voice over IP (VoIP) using Cisco Broadband Telephony Softswitch (BTS) 10200 Softswitch call agent, versions 3.5 and 4.1, in a PacketCable network that conforms to PacketCable Event Message Specification version I03.



The *PacketCable Control Point Discovery Interface Specification* document defines an IP-based protocol that can be used to discover a control point for a given IP address. The control point is the place where Quality of Service (QoS) operations, LI content tapping operations, or other operations may be performed.



---

**Note** The Cisco cBR router does not support PacketCable Communications Assistance for Law Enforcement Act (CALEA).

---

## Cisco cBR Series Routers

The Cisco cBR series router support two types of LI: regular and broadband (per-subscriber). Regular wiretaps are executed on access subinterfaces and physical interfaces. Wiretaps are not required, and are not executed, on internal interfaces. The router determines which type of wiretap to execute based on the interface that the target's traffic is using.

LI on the Cisco cBR series routers can intercept traffic based on a combination of one or more of the following fields:

- Destination IP address and mask (IPv4 or IPv6 address)
- Destination port or destination port range
- Source IP address and mask (IPv4 or IPv6 address)
- Source port or source port range
- Protocol ID
- Type of Service (TOS)
- Virtual routing and forwarding (VRF) name, which is translated to a *vrf-tableid* value within the router.
- Subscriber (user) connection ID
- Cable modem
- MAC address

The LI implementation on the Cisco cBR series routers is provisioned using SNMP3 and supports the following functionality:

- Interception of communication content. The router duplicates each intercepted packet and then places the copy of the packet within a UDP-header encapsulated packet (with a configured CCCid). The router sends the encapsulated packet to the LI mediation device. Even if multiple lawful intercepts are configured on the same data flow, only one copy of the packet is sent to the mediation device. If necessary, the mediation device can duplicate the packet for each LEA.
- Interception of IPv4, IPv4 multicast, IPv6, and IPv6 multicast flows.
- Maximum interception time—The maximum value of **cTap2MediationTimeout** is 260640 minutes or 181 days from the current time. The minimum value for **cTap2MediationTimeout** is 1 minute from the current time.

LI includes two ways of setting a MAC-based tap:

- On CPE—Only intercepts traffic whose source or destination match the MAC address of the CPE device.
- On CM—Intercepts all of the traffic behind the CM, including the CM traffic itself. This form of intercept might generate a lot of traffic to the mediation device.

## VRF Aware LI

VRF Aware LI is the ability to provision a LI wiretap on IPv4 data in a particular Virtual Private Network (VPN). This feature allows a LEA to lawfully intercept targeted data within that VPN. Only IPv4 data within that VPN is subject to the VRF-based LI tap.

VRF Aware LI is available for the following types of traffic:

- ip2ip
- ip2tag (IP to MPLS)
- tag2ip (MPLS to IP)

To provision a VPN-based IPv4 tap, the LI administrative function (running on the mediation device) uses the CISCO-IP-TAP-MIB to identify the name of the VRF table that the targeted VPN uses. The VRF name is used to select the VPN interfaces on which to enable LI in order to execute the tap.

The router determines which traffic to intercept and which mediation device to send the intercepted packets based on the VRF name (along with the source and destination address, source and destination port, and protocol).



---

**Note** When using the Cisco-IP-TAP-MIB, if the VRF name is not specified in the stream entry, the global IP routing table is used by default.

---

## Lawful Intercept- Redundant Mediation Devices

The Cisco cBR Series Converged Broadband Routers supports replicating Lawful Intercept (LI) packets to multiple Mediation Devices (MDs). To use this feature, multiple identical taps are configured. The Cisco cBR Series Converged Broadband Routers support up to two identical taps to replicate to two MDs. Only MAC- and CM-taps are supported with multiple MDs.

For a sample SNMP configuration command set to configure two identical taps to tap to two MDs, see [Example: Configuring Lawful Intercept- Redundant Mediation Devices, on page 1588](#).

## Lawful Intercept MIBs

Due to its sensitive nature, the Cisco LI MIBs are only available in software images that support the LI feature. These MIBs are not accessible through the Network Management Software MIBs Support page (<http://www.cisco.com/public/sw-center/netmgmt/cmtk/mibs.shtml>).

## Restricting Access to the Lawful Intercept MIBs

Only the mediation device and users who need to know about lawful intercepts should be allowed to access the LI MIBs. To restrict access to these MIBs, you must:

1. Create a view that includes the Cisco LI MIBs.
2. Create an SNMP user group that has read-and-write access to the view. Only users assigned to this user group can access information in the MIBs.
3. Add users to the Cisco LI user groups to define who can access the MIBs and any information related to lawful intercepts. Be sure to add the mediation device as a user in this group; otherwise, the router cannot perform lawful intercepts.

For more information, see the *Creating a Restricted SNMP View of Lawful Intercept MIBs* module.



---

**Note** Access to the Cisco LI MIB view should be restricted to the mediation device and to system administrators who need to be aware of lawful intercepts on the router. To access the MIB, users must have level-15 access rights on the router.

---

## Service Independent Intercept

Cisco developed the Service Independent Intercept (SII) architecture in response to requirements that support lawful intercept for service provider customers. The SII architecture offers well-defined, open interfaces between the Cisco equipment acting as the content Intercept Access Point (IAP) and the mediation device. The modular nature of the SII architecture allows the service provider to choose the most appropriate mediation device to meet specific network requirements and regional, standards-based requirements for the interface to the law enforcement collection function.

The mediation device uses SNMPv3 to instruct the call connect (CC) IAP to replicate the CC and send the content to the mediation device. The CC IAP can be either an edge router or a trunking gateway for voice, and either an edge router or an access server for data.



---

**Note** The Cisco cBR router does not support encryption of lawful intercept traffic.

---

To increase the security and to mitigate any SNMPv3 vulnerability, the following task is required:

### Restricting Access to Trusted Hosts (without Encryption)

SNMPv3 provides support for both security models and security levels. A security model is an authentication strategy that is set up for a user and the group in which the user resides. A security level is the permitted level of security within a security model. A combination of a security model and a security level will determine the security mechanism employed when handling an SNMP packet.

Additionally, the SNMP Support for the Named Access Lists feature adds support for standard named access control lists (ACLs) to several SNMP commands.

To configure a new SNMP group or a table that maps SNMP users to SNMP views, use the **snmp-server group** command in global configuration mode.

```
access-list my-list permit ip host 10.10.10.1
snmp-server group my-group v3 auth access my-list
```

In this example, the access list named **my-list** allows SNMP traffic only from 10.10.10.1. This access list is then applied to the SNMP group called **my-group**.

## How to Configure Lawful Intercept

Although there are no direct user commands to provision lawful intercept on the router, you do need to perform some configuration tasks, such as providing access to LI MIBs, and setting up SNMP notifications. This section describes how to perform the required tasks:

### Creating a Restricted SNMP View of Lawful Intercept MIBs

To create and assign users to an SNMP view that includes the Cisco lawful intercept MIBs, perform the steps in this section.

#### Before you begin

- You must issue the commands in global configuration mode with level-15 access rights.
- SNMPv3 must be configured on the device.

#### Procedure

|               | Command or Action                                                                                                                                                  | Purpose                                                                                                                                                                                                        |
|---------------|--------------------------------------------------------------------------------------------------------------------------------------------------------------------|----------------------------------------------------------------------------------------------------------------------------------------------------------------------------------------------------------------|
| <b>Step 1</b> | <b>enable</b><br><b>Example:</b><br><br>Device> enable                                                                                                             | Enables privileged EXEC mode.<br><br>• Enter your password if prompted.                                                                                                                                        |
| <b>Step 2</b> | <b>configure terminal</b><br><b>Example:</b><br><br>Device# configure terminal                                                                                     | Enters global configuration mode.                                                                                                                                                                              |
| <b>Step 3</b> | <b>snmp-server view</b> <i>view-name MIB-name</i> <b>included</b><br><b>Example:</b><br><br>Device(config)# snmp-server view exampleView<br>ciscoTap2MIB included  | Creates an SNMP view that includes the CISCO-TAP2-MIB (where <i>exampleView</i> is the name of the view to create for the MIB).<br><br>• This MIB is required for both regular and broadband lawful intercept. |
| <b>Step 4</b> | <b>snmp-server view</b> <i>view-name MIB-name</i> <b>included</b><br><b>Example:</b><br><br>Device(config)# snmp-server view exampleView<br>ciscoIpTapMIB included | Adds the CISCO-IP-TAP-MIB to the SNMP view.                                                                                                                                                                    |
| <b>Step 5</b> | <b>snmp-server view</b> <i>view-name MIB-name</i> <b>included</b><br><b>Example:</b>                                                                               | Adds the CISCO-802-TAP-MIB to the SNMP view.                                                                                                                                                                   |

|               | Command or Action                                                                                                                                                                                                                 | Purpose                                                                                                          |
|---------------|-----------------------------------------------------------------------------------------------------------------------------------------------------------------------------------------------------------------------------------|------------------------------------------------------------------------------------------------------------------|
|               | Device(config)# snmp-server view exampleView<br>cisco802TapMIB included                                                                                                                                                           |                                                                                                                  |
| <b>Step 6</b> | <b>snmp-server group</b> <i>group-name</i> <b>v3 noauth read</b><br><i>view-name write view-name</i><br><br><b>Example:</b><br><br>Device(config)# snmp-server group exampleGroup v3<br>noauth read exampleView write exampleView | Creates an SNMP user group that has access to the LI MIB view and defines the group's access rights to the view. |
| <b>Step 7</b> | <b>snmp-server user</b> <i>user-name group-name</i> <b>v3 auth</b><br><b>md5</b> <i>auth-password</i><br><br><b>Example:</b><br><br>Device(config)# snmp-server user exampleUser<br>exampleGroup v3 auth md5 examplePassword      | Adds users to the specified user group.                                                                          |
| <b>Step 8</b> | <b>end</b><br><br><b>Example:</b><br><br>Device(config)# end                                                                                                                                                                      | Exits the current configuration mode and returns to privileged EXEC mode.                                        |

## Where to Go Next

The mediation device can now access the lawful intercept MIBs and issue SNMP **set** and **get** requests to configure and run lawful intercepts on the router. To configure the router to send SNMP notification to the mediation device, see the Enabling SNMP Notifications for Lawful Intercept.

## Enabling SNMP Notifications for Lawful Intercept

SNMP automatically generates notifications for lawful intercept events. To configure the router to send lawful intercept notifications to the mediation device, perform the steps in this section.

### Before you begin

- You must issue the commands in global configuration mode with level-15 access rights.
- SNMPv3 must be configured on the router.

### SUMMARY STEPS

1. **enable**
2. **configure terminal**
3. **snmp-server host** *ip-address* **community-string udp-port** *port notification-type*
4. **snmp-server enable traps snmp authentication linkup linkdown coldstart warmstart** *and snmp-server enable traps rf*
5. **end**

## DETAILED STEPS

|               | Command or Action                                                                                                                                                                                                                                                                                 | Purpose                                                                                                                                                                                                                          |
|---------------|---------------------------------------------------------------------------------------------------------------------------------------------------------------------------------------------------------------------------------------------------------------------------------------------------|----------------------------------------------------------------------------------------------------------------------------------------------------------------------------------------------------------------------------------|
| <b>Step 1</b> | <b>enable</b><br><b>Example:</b><br><br>Device> enable                                                                                                                                                                                                                                            | Enables privileged EXEC mode.<br><br>• Enter your password if prompted.                                                                                                                                                          |
| <b>Step 2</b> | <b>configure terminal</b><br><b>Example:</b><br><br>Device# configure terminal                                                                                                                                                                                                                    | Enters global configuration mode.                                                                                                                                                                                                |
| <b>Step 3</b> | <b>snmp-server host ip-address community-string udp-port port notification-type</b><br><b>Example:</b><br><br>Device(config)# snmp-server 10.2.2.1 community-string udp-port 161 udp                                                                                                              | Specifies the IP address of the mediation device and the password-like community-string that is sent with a notification request.<br><br>• For lawful intercept, the <b>udp-port</b> must be 161 and not 162 (the SNMP default). |
| <b>Step 4</b> | <b>snmp-server enable traps snmp authentication linkup linkdown coldstart warmstart and snmp-server enable traps rf</b><br><b>Example:</b><br><br>Device(config)# snmp-server enable traps snmp authentication linkup linkdown coldstart warmstart<br>Device(config)# snmp-server enable traps rf | Configures the router to send RFC 1157 notifications to the mediation device.<br><br>These notifications indicate authentication failures, link status (up or down), and router restarts.                                        |
| <b>Step 5</b> | <b>end</b><br><b>Example:</b><br><br>Device(config)# end                                                                                                                                                                                                                                          | Exits the current configuration mode and returns to privileged EXEC mode.                                                                                                                                                        |

## Disabling SNMP Notifications

To disable SNMP notifications on the router, perform the steps in this section.



**Note** To disable lawful intercept notifications, use SNMPv3 to set the CISCO-TAP2-MIB object cTap2MediationNotificationEnable to false(2). To reenable lawful intercept notifications through SNMPv3, reset the object to true(1).

## SUMMARY STEPS

1. **enable**
2. **configure terminal**

3. `no snmp-server enable traps`
4. `end`

#### DETAILED STEPS

|        | Command or Action                                                                                    | Purpose                                                                                                            |
|--------|------------------------------------------------------------------------------------------------------|--------------------------------------------------------------------------------------------------------------------|
| Step 1 | <b>enable</b><br><b>Example:</b><br>Device> enable                                                   | Enables privileged EXEC mode. <ul style="list-style-type: none"> <li>• Enter your password if prompted.</li> </ul> |
| Step 2 | <b>configure terminal</b><br><b>Example:</b><br>Device# configure terminal                           | Enters global configuration mode.                                                                                  |
| Step 3 | <b>no snmp-server enable traps</b><br><b>Example:</b><br>Device(config)# no snmp-server enable traps | Disables all SNMP notification types that are available on your system.                                            |
| Step 4 | <b>end</b><br><b>Example:</b><br>Device(config)# end                                                 | Exits the current configuration mode and returns to privileged EXEC mode.                                          |

## Provisioning a MAC Intercept for Cable Modems Using SNMPv3

1. Configure the `c802tapStreamInterface` object.
2. Set the following bit flags in the `c802tapStreamFields` object:
  - `dstMacAddress` (bit 1)
  - `srcMacAddress` (bit 2)
  - `cmMacAddress` (bit 6)—The `cmMacAddress` bit field is newly introduced for cable modem support and determines whether the intercept is a CPE-based or CM-based intercept.
3. Configure the following objects with the same CM MAC address value:
  - `c802tapStreamDestinationAddress`
  - `c802tapStreamSourceAddress`

## Provisioning a MAC Intercept for a CPE Device Using SNMPv3

1. Configure the `c802tapStreamInterface` object.
2. Set the following bit flags in the `c802tapStreamFields` object:
  - `dstMacAddress` (bit 1)
  - `srcMacAddress` (bit 2)

3. Configure the following objects with the same CPE MAC address value:
  - c802tapStreamDestinationAddress
  - c802tapStreamSourceAddress

## Configuration Examples for Lawful Intercept

### Example: Enabling Mediation Device Access Lawful Intercept MIBs

The following example shows how to enable the mediation device to access the lawful intercept MIBs. It creates an SNMP view (tapV) that includes four LI MIBs (CISCO-TAP2-MIB, CISCO-IP-TAP-MIB, CISCO-802-TAP-MIB, and CISCO-USER-CONNECTION-TAP-MIB). It also creates a user group that has read, write, and notify access to MIBs in the tapV view.

```
snmp-server view tapV ciscoTap2MIB included
snmp-server view tapV ciscoIpTapMIB included
snmp-server view tapV cisco802TapMIB included
snmp-server view tapV ciscoUserConnectionTapMIB included
snmp-server group tapGrp v3 noauth read tapV write tapV notify tapV
snmp-server user MDuser tapGrp v3 auth md5 MDpasswd
snmp-server engineID local 1234
```

### Example: Configuring Lawful Intercept- Redundant Mediation Devices

Lawful Intercept is configured using SNMPv3. The following example shows SNMP configuration command set to configure two identical taps to tap two MDs:

- Setup MD1:

```
setany -v3 -timeout 30 -retries 3 10.12.0.34 user1 \
cTap2MediationStatus.1 -i 4 \
cTap2MediationDestAddressType.1 -i 1 \
cTap2MediationTimeout.1 -o 07:E0:04:01:B:15:1A:0 \
cTap2MediationTransport.1 -i 1 \
cTap2MediationSrcInterface.1 -i 0 \
cTap2MediationDestAddress.1 -o 0a:0a:00:35 \
cTap2MediationDestPort.1 -g 63
```

- Setup CM tap:

```
setany -v3 -timeout 30 -retries 3 10.12.0.34 user1 \
c802tapStreamStatus.1.2 -i 4 \
c802tapStreamFields.1.2 -o 62 \
c802tapStreamInterface.1.2 -i -1 \
c802tapStreamDestinationAddress.1.2 -o "c8 fb 26 a5 55 98" \
c802tapStreamSourceAddress.1.2 -o "c8 fb 26 a5 55 98"

setany -v3 -timeout 30 -retries 3 10.12.0.34 user1 \
cTap2StreamStatus.1.2 -i 5 \
cTap2StreamType.1.2 -i 2 \
cTap2StreamInterceptEnable.1.2 -i 1 \
cTap2StreamStatus.1.2 -i 4
```



- Setup MD2:

```
setany -v3 -timeout 30 -retries 3 10.12.0.34 user1 \
cTap2MediationStatus.2 -i 4 \
cTap2MediationDestAddressType.2 -i 1 \
cTap2MediationTimeout.2 -o 07:E0:03:03:7:15:1A:0 \
cTap2MediationTransport.2 -i 1 \
cTap2MediationSrcInterface.2 -i 0 \
cTap2MediationDestAddress.2 -o 0a:0a:00:06 \
cTap2MediationDestPort.2 -g 63
```

- Setup CM tap:

```
setany -v3 -timeout 30 -retries 3 10.12.0.34 user1 \
c802tapStreamStatus.2.2 -i 4 \
c802tapStreamFields.2.2 -o 62 \
c802tapStreamInterface.2.2 -i -1 \
c802tapStreamDestinationAddress.2.2 -o "c8 fb 26 a5 55 98" \
c802tapStreamSourceAddress.2.2 -o "c8 fb 26 a5 55 98"

setany -v3 -timeout 30 -retries 3 10.12.0.34 user1 \
cTap2StreamStatus.2.2 -i 5 \
cTap2StreamType.2.2 -i 2 \
cTap2StreamInterceptEnable.2.2 -i 1 \
cTap2StreamStatus.2.2 -i 4
```

- Get tapped packets count:

```
getmany -v3 -timeout 30 -retries 3 10.12.0.34 user1 \
cTap2StreamInterceptedPackets
```

## Additional References

### Related Documents

| Related Topic            | Document Title                              |
|--------------------------|---------------------------------------------|
| Configuring SNMP Support | <i>Configuring SNMP Support</i>             |
| Security commands        | <i>Cisco IOS Security Command Reference</i> |

### Standards and RFCs

| Standard/RFC                                                 | Title                                                                                       |
|--------------------------------------------------------------|---------------------------------------------------------------------------------------------|
| PacketCable™ Control Point Discovery Interface Specification | <i>PacketCable™ Control Point Discovery Interface Specification (PKT-SP-CPD-I02-061013)</i> |
| RFC-3924                                                     | <i>Cisco Architecture for Lawful Intercept in IP Networks</i>                               |

**MIBs**

| MIB                                                                                                                                                                  | MIBs Link                                                                                                                                                                                                                         |
|----------------------------------------------------------------------------------------------------------------------------------------------------------------------|-----------------------------------------------------------------------------------------------------------------------------------------------------------------------------------------------------------------------------------|
| <ul style="list-style-type: none"> <li>• CISCO-TAP2-MIB</li> <li>• CISCO-IP-TAP-MIB</li> <li>• CISCO-802-TAP-MIB</li> <li>• CISCO-USER-CONNECTION-TAP-MIB</li> </ul> | <p>To locate and download MIBs for selected platforms, Cisco IOS releases, and feature sets, use Cisco MIB Locator found at the following URL:</p> <p><a href="http://www.cisco.com/go/mibs">http://www.cisco.com/go/mibs</a></p> |

**Technical Assistance**

| Description                                                                                                                                                                                                                                                                                                                                                                                                                                                                                                                                                             | Link                                                                           |
|-------------------------------------------------------------------------------------------------------------------------------------------------------------------------------------------------------------------------------------------------------------------------------------------------------------------------------------------------------------------------------------------------------------------------------------------------------------------------------------------------------------------------------------------------------------------------|--------------------------------------------------------------------------------|
| <p>The Cisco Support website provides extensive online resources, including documentation and tools for troubleshooting and resolving technical issues with Cisco products and technologies.</p> <p>To receive security and technical information about your products, you can subscribe to various services, such as the Product Alert Tool (accessed from Field Notices), the Cisco Technical Services Newsletter, and Really Simple Syndication (RSS) Feeds.</p> <p>Access to most tools on the Cisco Support website requires a Cisco.com user ID and password.</p> | <p><a href="http://www.cisco.com/support">http://www.cisco.com/support</a></p> |

## Feature Information for Lawful Intercept

Use Cisco Feature Navigator to find information about the platform support and software image support. Cisco Feature Navigator enables you to determine which software images support a specific software release, feature set, or platform. To access Cisco Feature Navigator, go to the <https://cfng.cisco.com/> link. An account on the Cisco.com page is not required.



**Note** The following table lists the software release in which a given feature is introduced. Unless noted otherwise, subsequent releases of that software release train also support that feature.

*Table 314: Feature Information for Lawful Intercept*

| Feature Name                                   | Releases                    | Feature Information                                                                                               |
|------------------------------------------------|-----------------------------|-------------------------------------------------------------------------------------------------------------------|
| Lawful intercept - Redundant mediation devices | Cisco IOS XE Everest 16.6.1 | This feature was integrated into Cisco IOS XE Everest 16.6.1 on the Cisco cBR Series Converged Broadband Routers. |



## CHAPTER 100

# Cable Monitoring Feature for Cisco cBR Series Routers

---

After you configure cable monitoring, the router forwards copies of selected packets on the cable interface to an external LAN analyzer attached to another interface on the Cisco CMTS router. This command can help in troubleshooting network and application problems.



---

**Note** This feature does not monitor traffic for the purpose of preventing denial-of-service attacks and other types of network attacks. Even after configuring the cable monitoring feature, the traffic continues to its original destination, and only copies of the selected packets are forwarded to the CALEA server or LAN analyzer.

---



---

**Note** This feature doesn't support line card high availability (LCHA).

---

Your software release may not support all the features that are documented in this module. For the latest feature information and caveats, see the release notes for your platform and software release. The Feature Information Table at the end of this document provides information about the documented features and lists the releases in which each feature is supported.

Use Cisco Feature Navigator to find information about platform support and Cisco software image support. To access Cisco Feature Navigator, go to <http://tools.cisco.com/ITDIT/CFN/>. An account on <http://www.cisco.com/> is not required.

### Contents

- [Overview of Cable Monitor Command for cBR, on page 1592](#)
- [Configuring Cable Monitoring for cBR Routers, on page 1592](#)
- [Capturing Sniffed Packets, on page 1594](#)
- [Cable Monitor Packet Struct, on page 1597](#)
- [Feature Information for Cable Monitoring, on page 1597](#)

## Overview of Cable Monitor Command for cBR

The **cable monitor** command sends copies of packets for specific types of traffic that is sent over a particular cable interface to a LAN analyzer, for use in troubleshooting network problems. This command can select packets to be forwarded using one or more of the following parameters:

- Either incoming or outbound packets
- Packets that match a specific MAC address (source and destination)
- Packets with a specific Service ID (SID)

Packets can also be timestamped to aid in troubleshooting. The packets are then forwarded out of the specified 10 Gigabit Ethernet port to the LAN analyzer for additional analysis.

The figure below illustrates a LAN packet analyzer attached to a Fast Ethernet port in a DOCSIS two-way configuration.

**Figure 39: LAN Packet Analyzer in a DOCSIS Two-Way Configuration**

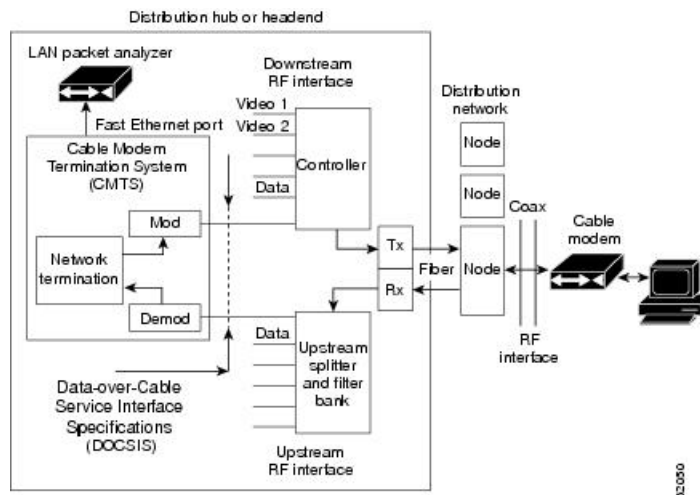

**Note** The WAN port used for cable monitoring should be exclusively used by the LAN packet analyzer.

## Configuring Cable Monitoring for cBR Routers

To enable the cable traffic monitoring feature on a particular cable interface, use the following procedure, starting in privileged EXEC mode.

### SUMMARY STEPS

1. **enable**
2. **configure terminal**
3. **cable monitor**

4. `sniff card <slot num> <ds/us> <sniff point> <filter> dest cmon-tunnel <cmon-tunnel num>`
5. `end`

## DETAILED STEPS

|        | Command or Action                                                                                                                                                                                                                                                                                                                                                                                                                                                                                                                                                                                                                                                                                                                                                              | Purpose                                                                                                                                                                                                                                                                                                                                                                                                                                                                                                                           |
|--------|--------------------------------------------------------------------------------------------------------------------------------------------------------------------------------------------------------------------------------------------------------------------------------------------------------------------------------------------------------------------------------------------------------------------------------------------------------------------------------------------------------------------------------------------------------------------------------------------------------------------------------------------------------------------------------------------------------------------------------------------------------------------------------|-----------------------------------------------------------------------------------------------------------------------------------------------------------------------------------------------------------------------------------------------------------------------------------------------------------------------------------------------------------------------------------------------------------------------------------------------------------------------------------------------------------------------------------|
| Step 1 | <p><b>enable</b></p> <p><b>Example:</b></p> <pre>Router&gt; enable</pre> <p><b>Example:</b></p> <pre>Router#</pre>                                                                                                                                                                                                                                                                                                                                                                                                                                                                                                                                                                                                                                                             | Enables privileged EXEC mode. Enter your password if prompted.                                                                                                                                                                                                                                                                                                                                                                                                                                                                    |
| Step 2 | <p><b>configure terminal</b></p> <p><b>Example:</b></p> <pre>Router# configure terminal</pre> <p><b>Example:</b></p> <pre>Router(config)#</pre>                                                                                                                                                                                                                                                                                                                                                                                                                                                                                                                                                                                                                                | Enters global configuration mode.                                                                                                                                                                                                                                                                                                                                                                                                                                                                                                 |
| Step 3 | <p><b>cable monitor</b></p> <p><b>Example:</b></p> <pre>Router(config)# cable monitor</pre> <p><b>Example:</b></p> <pre>Router(config-cable-monitor)#</pre>                                                                                                                                                                                                                                                                                                                                                                                                                                                                                                                                                                                                                    | Enters cable monitor configuration mode.                                                                                                                                                                                                                                                                                                                                                                                                                                                                                          |
| Step 4 | <p><b>sniff card &lt;slot num&gt; &lt;ds/us&gt; &lt;sniff point&gt; &lt;filter&gt; dest cmon-tunnel &lt;cmon-tunnel num&gt;</b></p> <p><b>Example:</b></p> <p>Downstream traffic: For each channel</p> <pre>Router(config-cable-monitor)sniff card 3 outbound docsis integrated-Cable 3/0/0:0 dest cmon-tunnel 3</pre> <p><b>Example:</b></p> <p>Downstream traffic: For each wideband channel</p> <pre>Router(config-cable-monitor)sniff card 3 outbound pre-docsis wideband-Cable 3/0/0:0 dest cmon-tunnel 3</pre> <p><b>Example:</b></p> <p>Downstream traffic: For each MAC address</p> <pre>Router(config-cable-monitor)sniff card 3 outbound docsis mac-address 0100.5e01.0101 dest cmon-tunnel 3</pre> <p><b>Example:</b></p> <p>Upstream traffic: For each channel</p> | <p>Configures the card to forward the sniffed packets.</p> <ul style="list-style-type: none"> <li>• <b>slot number</b>—Slot number of the line card</li> <li>• <b>ds/us</b>—Downstream or upstream</li> <li>• <b>sniff point</b>—Sniff point in downstream or upstream FPGA (field-programmable gate array)</li> <li>• <b>filter</b>—Packet type filter</li> <li>• <b>dest cmon-tunnel</b>—Cable monitor tunnel for captured packets</li> <li>• <b>cmon-tunnel num</b>—Cable monitor tunnel number for capture packets</li> </ul> |

|               | Command or Action                                                                                                                                                                                                                                                                                                                                                                                                                                                                                                                 | Purpose                          |
|---------------|-----------------------------------------------------------------------------------------------------------------------------------------------------------------------------------------------------------------------------------------------------------------------------------------------------------------------------------------------------------------------------------------------------------------------------------------------------------------------------------------------------------------------------------|----------------------------------|
|               | <pre>Router(config-cable-monitor)# sniff card 3 incoming post-docsis upstream-cable 3/0/0 us-channel 0 dest cmon-tunnel 3</pre> <p><b>Example:</b><br/>Upstream traffic: For each MAC address (cable modem or CPE)</p> <pre>Router(config-cable-monitor)#sniff card 3 incoming post-docsis mac-address e448.c70c.9c27 dest cmon-tunnel 3</pre> <p><b>Example:</b><br/>Upstream traffic: For MD/SID</p> <pre>Router(config-cable-monitor)#sniff card 3 incoming post-docsis cable 3/0/0 sid 12 upstream 0 dest cmon-tunnel 3</pre> |                                  |
| <b>Step 5</b> | <p><b>end</b></p> <p><b>Example:</b></p> <pre>Router(config)# end</pre> <p><b>Example:</b></p> <pre>Router#</pre>                                                                                                                                                                                                                                                                                                                                                                                                                 | Exits global configuration mode. |

### What to do next

You can capture and forward the sniffed packets to an external server or a local hard disk. For more details, see [Capturing Sniffed Packets, on page 1594](#).

## Capturing Sniffed Packets

To forward the captured traffic to an external server, you should configure a tunnel. The external server might not be directly connected and can be away from CMTS.

To capture sniffed packets, you can follow one of these procedures:

- Capture output packets using an external host
- Capture packets by locating the hard disk

## Capturing Sniffed Packets on an External Host

To forward the captured traffic to an external server, you should configure a tunnel. The external server might not be directly connected and can be away from CMTS.

**SUMMARY STEPS**

1. **configure terminal**
2. **interface cmon-tunnel number**
3. **tunnel destination IP address, tunnel source IP address**
4. **end**

**DETAILED STEPS**

|               | <b>Command or Action</b>                                                                                                                                                                                        | <b>Purpose</b>                                                                                              |
|---------------|-----------------------------------------------------------------------------------------------------------------------------------------------------------------------------------------------------------------|-------------------------------------------------------------------------------------------------------------|
| <b>Step 1</b> | <b>configure terminal</b><br><b>Example:</b><br>Router# <code>configure terminal</code><br><b>Example:</b><br>Router(config)#                                                                                   | Enters global configuration mode.                                                                           |
| <b>Step 2</b> | <b>interface cmon-tunnel number</b><br><b>Example:</b><br>Router(config)# <code>interface CMON-Tunnel 3</code><br>Router(config-if)#                                                                            | Enters the interface cmon-tunnel mode to capture sniffed packets.                                           |
| <b>Step 3</b> | <b>tunnel destination IP address, tunnel source IP address</b><br><b>Example:</b><br>Router(config-if)# <code>tunnel destination 10.10.21.11</code><br>Router(config-if)# <code>tunnel source 10.10.21.1</code> | Configures destination IP address and the source IP address for an external host to capture output packets. |
| <b>Step 4</b> | <b>end</b><br><b>Example:</b><br>Router(config)# <code>end</code><br><b>Example:</b><br>Router#                                                                                                                 | Exits global configuration mode.                                                                            |

**Capturing Sniffed Packets on a Local Hard Drive**

To forward the captured traffic to a local hard disk, use the following procedure.

**SUMMARY STEPS**

1. **configure terminal**
2. **interface cmon-tunnel number**
3. **mode buffer**
4. **end**
5. **show platform software interface fp active name-string CMON-Tunnel number**
6. **test platform hardware qfp active feature docsis cmon-copy 3 QFP\_ID**

## DETAILED STEPS

|               | Command or Action                                                                                                                                                                                                                                                                                                                                                                                                                                                                                                                                                                                                                                                                                                                                                                                                                               | Purpose                                                                              |
|---------------|-------------------------------------------------------------------------------------------------------------------------------------------------------------------------------------------------------------------------------------------------------------------------------------------------------------------------------------------------------------------------------------------------------------------------------------------------------------------------------------------------------------------------------------------------------------------------------------------------------------------------------------------------------------------------------------------------------------------------------------------------------------------------------------------------------------------------------------------------|--------------------------------------------------------------------------------------|
| <b>Step 1</b> | <b>configure terminal</b><br><b>Example:</b><br>Router# <b>configure</b> CMON-Tunnel 3<br><b>Example:</b><br>Router(config)#                                                                                                                                                                                                                                                                                                                                                                                                                                                                                                                                                                                                                                                                                                                    | Enters global configuration mode.                                                    |
| <b>Step 2</b> | <b>interface cmon-tunnel number</b><br><b>Example:</b><br>Router(config)# <b>interface</b> CMON-Tunnel 3<br>Router(config-if)#                                                                                                                                                                                                                                                                                                                                                                                                                                                                                                                                                                                                                                                                                                                  | Enters the interface cmon-tunnel mode.                                               |
| <b>Step 3</b> | <b>mode buffer</b><br><b>Example:</b><br>Router(config-if)# <b>mode</b> buffer                                                                                                                                                                                                                                                                                                                                                                                                                                                                                                                                                                                                                                                                                                                                                                  | Enables mode buffer in the cmon-tunnel to capture packets by locating the hard disk. |
| <b>Step 4</b> | <b>end</b><br><b>Example:</b><br>Router(config-if)# <b>end</b><br>Router#                                                                                                                                                                                                                                                                                                                                                                                                                                                                                                                                                                                                                                                                                                                                                                       | Exits global configuration mode.                                                     |
| <b>Step 5</b> | <b>show platform software interface fp active name-string CMON-Tunnel number</b><br><b>Example:</b><br>Router# <b>show platform software interface fp active name-string</b> CMON-Tunnel3<br>Name: CMON-Tunnel3, ID: 131074, QFP ID: 11745,<br>Schedules: 0<br>Type: CABLE-MONITOR, State: enabled, SNMP ID: 0,<br>MTU: 0<br>IP Address: 0.0.0.0<br>IPV6 Address: ::<br>Flags: unknown<br>ICMP Flags: unreachable, no-redirects,<br>no-info-reply, no-mask-reply<br>ICMP6 Flags: unreachable, no-redirects<br>SMI enabled on protocol(s): UNKNOWN<br>Authenticated-user:<br>FRR linkdown ID: 65535<br>Monitor Type: 0, Instance ID: 3, Mode: 3<br>Monitor Tunnel Source: 0.0.0.0, Destination:<br>0.0.0.0<br>vNet Name: , vNet Tag: 0, vNet Extra Information:<br>0<br>Dirty: unknown<br>AOM dependency sanity check: PASS<br>AOM Obj ID: 24094 | Gets the QFP ID.                                                                     |
| <b>Step 6</b> | <b>test platform hardware qfp active feature docsis cmon-copy 3 QFP_ID</b>                                                                                                                                                                                                                                                                                                                                                                                                                                                                                                                                                                                                                                                                                                                                                                      | Uses the QFP ID to copy the buffer to the harddisk.                                  |



|  | Command or Action                                                                                                                                                                                                          | Purpose |
|--|----------------------------------------------------------------------------------------------------------------------------------------------------------------------------------------------------------------------------|---------|
|  | <b>Example:</b><br><pre>Router# test platform hardware qfp active feature docsis cmon-copy 3 11745 Router #dir harddisk:   in CMON  50 -rw-                24 Mar 5 2020 12:33:42 +02:00 CMON_3_20200305-123342.pcap</pre> |         |

## Cable Monitor Packet Struct

The cable monitor packet struct is described as follows:

- For post-docsis and pre-docsis sniffer points: Internal Header (16 Bytes) + Ethernet Header
- For docsis sniffer point: Internal Header (16 Bytes) + Docsis Header + Ethernet Header

If **remove-jib** is configured under CMON-Tunnel interface, the packets will not contain Internal Header.

## Feature Information for Cable Monitoring

Use Cisco Feature Navigator to find information about the platform support and software image support. Cisco Feature Navigator enables you to determine which software images support a specific software release, feature set, or platform. To access Cisco Feature Navigator, go to the <https://cfmg.cisco.com/> link. An account on the Cisco.com page is not required.



**Note** The following table lists the software release in which a given feature is introduced. Unless noted otherwise, subsequent releases of that software release train also support that feature.

**Table 315: Feature Information for Cable Monitoring**

| Feature Name     | Releases                    | Feature Information                                                                                               |
|------------------|-----------------------------|-------------------------------------------------------------------------------------------------------------------|
| Cable Monitoring | Cisco IOS XE Everest 16.6.1 | This feature was integrated into Cisco IOS XE Everest 16.6.1 on the Cisco cBR Series Converged Broadband Routers. |





## CHAPTER 101

# Source-Based Rate Limit

The Source-Based Rate Limit (SBRL) feature prevents congestion of packets on the forwarding processor (FP) to the Route Processor (RP) interface, which can be caused by denial of service (DoS) attacks directed at the Cisco CMTS or by faulty hardware.

Your software release may not support all the features that are documented in this module. For the latest feature information and caveats, see the release notes for your platform and software release. The Feature Information Table at the end of this document provides information about the documented features and lists the releases in which each feature is supported.

Use Cisco Feature Navigator to find information about platform support and Cisco software image support. To access Cisco Feature Navigator, go to <http://tools.cisco.com/ITDIT/CFN/>. An account on <http://www.cisco.com/> is not required.

### Contents

- [Hardware Compatibility Matrix for the Cisco cBR Series Routers, on page 1599](#)
- [Prerequisites for Source-Based Rate Limit, on page 1600](#)
- [Restrictions for Source-Based Rate Limit, on page 1601](#)
- [Information About Source-Based Rate Limit, on page 1601](#)
- [How to Configure Source-Based Rate Limit, on page 1601](#)
- [Verifying the Source-Based Rate Limit Configuration, on page 1609](#)
- [Configuration Examples for Source-Based Rate Limit, on page 1614](#)
- [Default SBRL Configuration, on page 1616](#)
- [Conversion of SBRL Subscriber-side Configuration from 16.8.x to 16.9.x, on page 1617](#)
- [Conversion of Divert Rate Limit Configuration on the Cisco uBR10012 Router to SBRL Configuration on the Cisco cBR Series Routers, on page 1618](#)
- [Additional References, on page 1621](#)
- [Feature Information for Source-Based Rate Limit, on page 1621](#)

## Hardware Compatibility Matrix for the Cisco cBR Series Routers



**Note** The hardware components that are introduced in a given Cisco IOS-XE Release are supported in all subsequent releases unless otherwise specified.

Table 316: Hardware Compatibility Matrix for the Cisco cBR Series Routers

| Cisco CMTS Platform                    | Processor Engine                                                                                                                                                                                  | Interface Cards                                                                                                                                                                                                                                                                                                                                                                                                                                                                                                                                                                                                                                                                                                                                                                                 |
|----------------------------------------|---------------------------------------------------------------------------------------------------------------------------------------------------------------------------------------------------|-------------------------------------------------------------------------------------------------------------------------------------------------------------------------------------------------------------------------------------------------------------------------------------------------------------------------------------------------------------------------------------------------------------------------------------------------------------------------------------------------------------------------------------------------------------------------------------------------------------------------------------------------------------------------------------------------------------------------------------------------------------------------------------------------|
| Cisco cBR-8 Converged Broadband Router | <p><b>Cisco IOS-XE Release 16.5.1 and Later Releases</b></p> <p>Cisco cBR-8 Supervisor:</p> <ul style="list-style-type: none"> <li>• PID—CBR-SUP-250G</li> <li>• PID—CBR-CCAP-SUP-160G</li> </ul> | <p><b>Cisco IOS-XE Release 16.5.1 and Later Releases</b></p> <p>Cisco cBR-8 CCAP Line Cards:</p> <ul style="list-style-type: none"> <li>• PID—CBR-LC-8D30-16U30</li> <li>• PID—CBR-LC-8D31-16U30</li> <li>• PID—CBR-RF-PIC</li> <li>• PID—CBR-RF-PROT-PIC</li> <li>• PID—CBR-CCAP-LC-40G</li> <li>• PID—CBR-CCAP-LC-40G-R</li> <li>• PID—CBR-CCAP-LC-G2-R</li> <li>• PID—CBR-SUP-8X10G-PIC</li> <li>• PID—CBR-2X100G-PIC</li> </ul> <p>Digital PICs:</p> <ul style="list-style-type: none"> <li>• PID—CBR-DPIC-8X10G</li> <li>• PID—CBR-DPIC-2X100G</li> </ul> <p>Cisco cBR-8 Downstream PHY Module:</p> <ul style="list-style-type: none"> <li>• PID—CBR-D31-DS-MOD</li> </ul> <p>Cisco cBR-8 Upstream PHY Modules:</p> <ul style="list-style-type: none"> <li>• PID—CBR-D31-US-MOD</li> </ul> |



**Note** Do not use DPICs (8X10G and 2x100G) to forward IP traffic, as it may cause buffer exhaustion, leading to line card reload.

The only allowed traffic on a DPIC interface is DEPI, UEPI, and GCP traffic from the Cisco cBR-8 router to Remote PHY devices. Other traffic such as DHCP, SSH, and UTSC should flow via another router, since DPICs cannot be used for normal routing.

## Prerequisites for Source-Based Rate Limit

- You must configure Control-Plane Policing (CoPP) for WAN-side SBRL.

## Restrictions for Source-Based Rate Limit

- WAN-IP and Subscriber MAC address entities are identified using a hash, and hash collisions can occur between two (or more) entities.
- On the WAN-side there is no special processing for hash collisions. Sources that hash-collide are rate-limited as if they are the same source.
- The QOS group 99 is reserved for SBRL and cannot be used for other class maps.

## Information About Source-Based Rate Limit

Source-Based Rate Limit (SBRL) feature operates on the punt path in CPP. SBRL identifies and rate-limits the packet streams that can overload the punt path or RP.

Punted packets are sent from the FP to the RP through the FP-to-RP queues. Denial of service (DoS) can occur when:

- The FP-to-RP queues are congested
- The RP cannot process punted packets fast enough

In both cases, the valid punted packets are not processed properly. These situations can be caused deliberately by DoS attacks or by faulty external hardware.

Packet streams identified by SBRL are rate-limited according to configured parameters. Rate-limiting occurs in CPP before the packets reach the FP-to-RP queues. This protects the RP, and also allows other valid punted packets to reach the RP.

SBRL has a separate configuration for the WAN-side and the subscriber-side. WAN-side SBRL is disabled by default. Subscriber-side SBRL has default settings.

### WAN-Side Source-Based Rate Limit

WAN-side SBRL uses Control Plane Policing (CoPP). CoPP specifies the WAN-side packet streams that are directed for SBRL. Both trusted and untrusted sites can be specified using CoPP. Using CoPP, you can specify unlimited trusted sites. Access control list (ACL) is used to specify the trusted sites.

### Subscriber-Side Source-Based Rate Limit

All subscriber-side punts are processed by subscriber-side SBRL. Note that the CoPP processes all punted packets, but there is no dependency between CoPP and subscriber-side SBRL.

## How to Configure Source-Based Rate Limit

This section contains the following:

## Configuring WAN-Side Source-Based Rate Limit

You must enable WAN-side SBRL in two parts:

1. Configure Control Plane Policing (CoPP) to specify which packets are subject to SBRL.
2. Configure WAN-side SBRL to set the rate-limiting parameters for the specified punt-causes.

In the CoPP policy map, the special action **set qos-group 99** denotes that the packets matching a particular class are subject to WAN-side SBRL. This means that the QOS group 99 is globally reserved for SBRL, and must not be used in other policy-maps.

Packets matching a class without **set qos-group 99** bypass WAN-side SBRL. This means that CoPP is also used to specify trusted traffic streams that are not subject to WAN-side SBRL.

All punted packets are subject to CoPP. So, you must ensure that subscriber-side traffic does not match a trusted class.

WAN-side SBRL identifies traffic streams by hashing the punt cause, VRF index, and source IP address. This value is used as the index for rate-limiting. The router does not perform special processing for hash collisions, so hash-colliding streams are treated as if they are from the same stream.

By default, WAN-side SBRL is disabled.

### Restrictions

- All the punted packets are subject to CoPP and punt-policing.

This section contains the following:

## Configuring Control Plane Policing

Punted packets matching the trusted class bypass WAN-side SBRL. The rest of the WAN-side punts are sent to WAN-side SBRL.



**Note** The following example shows a simple trusted class.

### Procedure

|               | Command or Action                                                                                                                                                             | Purpose                                                                  |
|---------------|-------------------------------------------------------------------------------------------------------------------------------------------------------------------------------|--------------------------------------------------------------------------|
| <b>Step 1</b> | <b>enable</b><br><b>Example:</b><br>Router> <b>enable</b>                                                                                                                     | Enables privileged EXEC mode.<br><br>• Enter your password, if prompted. |
| <b>Step 2</b> | <b>configure terminal</b><br><b>Example:</b><br>Router# <b>configure terminal</b>                                                                                             | Enters global configuration mode.                                        |
| <b>Step 3</b> | <b>access-list</b> <i>access-list-number</i> <b>permit</b> <i>protocol</i> <b>{any   host {address   name}}</b> <b>{any   host {address   name}}</b><br><b>tos</b> <i>tos</i> | Configures an access list for filtering frames by protocol type.         |

|                | Command or Action                                                                                                                                                                                                               | Purpose                                                                                                                                                            |
|----------------|---------------------------------------------------------------------------------------------------------------------------------------------------------------------------------------------------------------------------------|--------------------------------------------------------------------------------------------------------------------------------------------------------------------|
|                | <b>Example:</b><br><pre>Router(config)# access-list 130 permit ip 192.168.1.10 0.0.0.0 192.168.1.11 0.0.0.0 tos 4</pre>                                                                                                         | <b>Note</b> Since all the punted packets are subject to CoPP, you must ensure that subscriber-side traffic does not match a trusted class.                         |
| <b>Step 4</b>  | <b>class-map</b> <i>class-map-name</i><br><br><b>Example:</b><br><pre>Router(config)# class-map match-all sbrl_v4_trusted</pre>                                                                                                 | Creates a class-map and enters QoS class-map configuration mode.                                                                                                   |
| <b>Step 5</b>  | <b>match access-group</b> <i>access-list-index</i><br><br><b>Example:</b><br><pre>Router(config-cmap)# match access-group 130</pre>                                                                                             | Specifies access groups to apply to an identity policy. The range of is from 1 to 2799.                                                                            |
| <b>Step 6</b>  | <b>exit</b><br><br><b>Example:</b><br><pre>Router(config-cmap)# exit</pre>                                                                                                                                                      | Exits QoS class-map configuration mode and returns to global configuration mode.                                                                                   |
| <b>Step 7</b>  | <b>policy-map</b> <i>policy-map-name</i><br><br><b>Example:</b><br><pre>Router(config)# policy-map copp_policy</pre>                                                                                                            | Specifies a service policy and enters QoS policy-map configuration mode.                                                                                           |
| <b>Step 8</b>  | <b>class</b> <i>class-map-name</i><br><br><b>Example:</b><br><pre>Router(config)# class sbrl_v4_trusted</pre>                                                                                                                   | Enters QoS policy-map class configuration mode.                                                                                                                    |
| <b>Step 9</b>  | <b>police rate</b> <i>units pps conform-action action</i><br><b>exceed-action</b> <i>action</i><br><br><b>Example:</b><br><pre>Router(config-pmap-c)# police rate 1000 pps conform-action transmit exceed-action transmit</pre> | Polices traffic destined for the control plane at a specified rate.<br><br><b>Note</b> The rate is irrelevant if both the configured actions are <b>transmit</b> . |
| <b>Step 10</b> | <b>exit</b><br><br><b>Example:</b><br><pre>Router(config-pmap-c)# exit</pre>                                                                                                                                                    | Exits policy-map class police configuration mode                                                                                                                   |
| <b>Step 11</b> | <b>class class-default</b><br><br><b>Example:</b><br><pre>Router(config-pmap)# class class-default</pre>                                                                                                                        | Specifies the action to take on the packets that do not match any other class in the policy map.                                                                   |
| <b>Step 12</b> | <b>set qos-group</b> <b>99</b><br><br><b>Example:</b><br><pre>Router(config-pmap-c)# set qos-group 99</pre>                                                                                                                     | Enables WAN-side SBRL for the packets that match this class.                                                                                                       |
| <b>Step 13</b> | <b>exit</b><br><br><b>Example:</b>                                                                                                                                                                                              | Exits policy-map class configuration mode                                                                                                                          |

|                | Command or Action                                                                                                                                  | Purpose                                                                                                                                                            |
|----------------|----------------------------------------------------------------------------------------------------------------------------------------------------|--------------------------------------------------------------------------------------------------------------------------------------------------------------------|
|                | <code>Router(config-pmap-c) # exit</code>                                                                                                          |                                                                                                                                                                    |
| <b>Step 14</b> | <b>exit</b><br><b>Example:</b><br><code>Router(config-pmap) # exit</code>                                                                          | Exits policy-map configuration mode                                                                                                                                |
| <b>Step 15</b> | <b>control-plane [host   transit   cef-exception]</b><br><b>Example:</b><br><code>Router(config) # control-plane</code>                            | Associates or modifies attributes (such as a service policy) that are associated with the control plane of the router and enters control plane configuration mode. |
| <b>Step 16</b> | <b>service-policy {input   output} policy-map-name</b><br><b>Example:</b><br><code>Router(config-cp) # service-policy input<br/>copp_policy</code> | Attaches a policy map to a control plane.                                                                                                                          |
| <b>Step 17</b> | <b>end</b><br><b>Example:</b><br><code>Router(config-cp) # end</code>                                                                              | Exits control plane configuration mode and returns to privileged EXEC mode.                                                                                        |

## Enabling WAN-Side Source-Based Rate Limit

### Procedure

|               | Command or Action                                                                                                                                                                         | Purpose                                                                                                                                                                                                                                                                                                                           |
|---------------|-------------------------------------------------------------------------------------------------------------------------------------------------------------------------------------------|-----------------------------------------------------------------------------------------------------------------------------------------------------------------------------------------------------------------------------------------------------------------------------------------------------------------------------------|
| <b>Step 1</b> | <b>enable</b><br><b>Example:</b><br><code>Router&gt; enable</code>                                                                                                                        | Enables privileged EXEC mode. <ul style="list-style-type: none"> <li>• Enter your password, if prompted.</li> </ul>                                                                                                                                                                                                               |
| <b>Step 2</b> | <b>configure terminal</b><br><b>Example:</b><br><code>Router# configure terminal</code>                                                                                                   | Enters global configuration mode.                                                                                                                                                                                                                                                                                                 |
| <b>Step 3</b> | <b>platform punt-sbri wan punt-cause punt-cause<br/>rate-per-1-sec rate</b><br><b>Example:</b><br><code>Router(config) # platform punt-sbri wan punt-cause<br/>10 rate-per-1-sec 4</code> | Configures WAN-side rate limit. <ul style="list-style-type: none"> <li>• <b>punt-cause</b> <i>punt-cause</i>—Specifies the punt-cause value in number 1 to 107 or string.</li> <li>• <b>rate-per-1-sec</b> <i>rate</i>—Specifies the rate in packets per second. The range is from 1 to 256, specified in powers-of-2.</li> </ul> |

## Configuring WAN-Side Quarantine

The WAN-side quarantine extends the WAN-side SBRL configuration. When a traffic stream enters quarantine, all punted packets in the stream are dropped for the configured period.



## Procedure

|        | Command or Action                                                                                                                                                                                                                                                                         | Purpose                                                                                                                                                                                                                                                                                                                                                                                                                                                                                                                                                                                                              |
|--------|-------------------------------------------------------------------------------------------------------------------------------------------------------------------------------------------------------------------------------------------------------------------------------------------|----------------------------------------------------------------------------------------------------------------------------------------------------------------------------------------------------------------------------------------------------------------------------------------------------------------------------------------------------------------------------------------------------------------------------------------------------------------------------------------------------------------------------------------------------------------------------------------------------------------------|
| Step 1 | <b>enable</b><br><b>Example:</b><br>Router> <b>enable</b>                                                                                                                                                                                                                                 | Enables privileged EXEC mode. <ul style="list-style-type: none"> <li>• Enter your password, if prompted.</li> </ul>                                                                                                                                                                                                                                                                                                                                                                                                                                                                                                  |
| Step 2 | <b>configure terminal</b><br><b>Example:</b><br>Router# <b>configure terminal</b>                                                                                                                                                                                                         | Enters global configuration mode.                                                                                                                                                                                                                                                                                                                                                                                                                                                                                                                                                                                    |
| Step 3 | <b>platform punt-sbri wan punt-cause <i>punt-cause</i> rate-per-1-sec <i>rate</i> quarantine-time <i>time</i> burst-factor <i>burst-factor</i></b><br><b>Example:</b><br>Router(config)# <b>platform punt-sbri wan punt-cause 10 rate-per-1-sec 4 quarantine-time 10 burst-factor 500</b> | Configures quarantine for the WAN-side packet stream. <ul style="list-style-type: none"> <li>• <b>punt-cause <i>punt-cause</i></b>—Specifies the punt-cause value in number 1 to 107 or string.</li> <li>• <b>rate-per-1-sec <i>rate</i></b>—Specifies the rate limit in packets per second. The range is from 1 to 256, specified in powers-of-2.</li> <li>• <b>quarantine-time <i>time</i></b>—Specifies the quarantine time, in minutes. The range is from 1 to 60.</li> <li>• <b>burst-factor <i>burst-factor</i></b>—Specifies the burst-factor, in number of packets. The range is from 50 to 1000.</li> </ul> |

## Example

When (*burst-factor x rate*) packets arrive at a rate faster than *rate*, the packet stream enters quarantine.

For example, during a DoS attack, when the following occurs:

- Punted packets from a WAN-side source arrive at 100 packets per second.
- WAN-side SBRL is configured with a rate of 4 packets per second, quarantine time of 10 minutes, and burst-factor of 500 packets.

The packet rate is significantly higher than the configured rate. Therefore, when 2000 (4 x 500) packets have arrived, the packet stream enters into quarantine. Quarantine is activated at 20 seconds (2000 packets per 100 packets per second), and all punted packets from the stream are dropped for 10 minutes. After 10 minutes, the quarantine is deactivated.

The quarantine calculations restart immediately. So, if the scanning attack is continuous, quarantine is reactivated after the next 20 seconds.

## Configuring Subscriber-Side Source-Based Rate Limit

### Restrictions

- All punted packets are subject to CoPP and punt-policing.

- The ARP-filter handles the subscriber-side ARP packets. ARP packets are not processed by subscriber-side SBRL.
- The maximum rate is 255. Due to this, the configured rate of 256 from 16.8.X will not transfer properly. A new command must be entered to transfer the configuration.

Subscriber-MAC address SBRL identifies traffic streams by hashing the punt cause and the source MAC address. The hash value is used as the index for rate-limiting. Hash-collision detection is performed so that all traffic streams are processed separately.

Default settings for subscriber-side SBRL are listed in this topic. Using the 'no' configuration returns the rate to the default value.

Rate-limiting is performed using a 2-color token-bucket algorithm. The rate is specified in packets-per-4-seconds, in the range [1, 255]. This translates to a packets-per-second rate in the range [0.25, ~64]. The optional bucket-size is specified in packets, in the range [1, 255]. If not specified, then bucket-size is set equal to rate.

The "no-drop" keyword disables rate-limiting for the specified punt-cause.

There is an optional quarantine configuration. When a traffic stream enters quarantine, all punted packets in the stream are dropped for the configured period. A traffic stream enters quarantine when (burst-factor x rate) packets arrive at a rate faster than rate. An example would be that of a faulty cable modem that continuously sends DHCPv6 solicits.

- DHCPv6 solicits from the faulty cable modem arrive at 100 packets/second, and are all punted.
- Subscriber-side SBRL is configured with a rate-per-4-sec of 8 (i.e. 2 packets-per-sec), quarantine time of 10 minutes, and burst-factor of 500 packets.

The traffic stream rate is higher than the configured rate. Therefore, when approximately 1000 (2 x 500) packets have arrived, the traffic stream enters quarantine. The quarantine happens after about 10 seconds (1000 packets at 100 packets per second), and all punted packets from the stream are dropped for 10 minutes. After 10 minutes, the quarantine is deactivated. The quarantine calculations restart immediately, so if the traffic stream remains continuous, quarantine is reactivated after the next 10 seconds.

### 1. enable

```
Router> enable
```

Enables privileged EXEC mode. Enter your password, if prompted.

### 2. configure terminal

```
Router# configure terminal
```

Enters global configuration mode.

### 3. platform punt-sbri subscriber punt-cause *punt-cause* rate-per-4-sec

```
rate [ bucket-size bucket-size ] [ quarantine-time time burst-factor burst-factor ]
```

Configures subscriber-MAC address SBRL.

- **punt-cause** *punt-cause* - Specifies the punt cause.
- **rate-per-4-sec** *rate* - Specifies the rate in packets per 4-seconds. The range is from 1 to 255.
- **bucket-size** *bucket-size* – Specifies the bucket-size in packets. The range is from 1 to 255. If bucket-size is not entered, the bucket-size is set equal to the rate.

- **quarantine-time** *time*– Specifies the quarantine time, in minutes. The range is from 1 to 60.
- **burst-factor** *burst-factor*– Specifies the burst-factor, in number of packets. The range is from 50 to 1000.

## Configuring Source-Based Rate Limit Ping-Bypass

Follow the steps below to configure source-based rate limit ping-bypass.

### Procedure

|        | Command or Action                                                                                                 | Purpose                                                                                                             |
|--------|-------------------------------------------------------------------------------------------------------------------|---------------------------------------------------------------------------------------------------------------------|
| Step 1 | <b>enable</b><br><b>Example:</b><br>Router> <b>enable</b>                                                         | Enables privileged EXEC mode. <ul style="list-style-type: none"> <li>• Enter your password, if prompted.</li> </ul> |
| Step 2 | <b>configure terminal</b><br><b>Example:</b><br>Router# <b>configure terminal</b>                                 | Enters global configuration mode.                                                                                   |
| Step 3 | <b>platform punt-sbri ping-bypass</b><br><b>Example:</b><br>Router(config)# <b>platform punt-sbri ping-bypass</b> | Configures source-based rate limit ping-bypass.                                                                     |

## Configuring SNMP RX Queuing

Table 317: Feature History

| Feature Name             | Release Information            | Feature Description                                                                                                                                                                                                                                                                                                                                                                                                          |
|--------------------------|--------------------------------|------------------------------------------------------------------------------------------------------------------------------------------------------------------------------------------------------------------------------------------------------------------------------------------------------------------------------------------------------------------------------------------------------------------------------|
| SNMP RX Queuing          | Cisco IOS XE Bengaluru 17.6.1a | This feature introduces a Control Plane Policing queue to shape incoming SNMP traffic in Cisco cBR-8 routers. It reduces the need for the SNMP poller to retransmit the polling request in case the request is dropped when SNMP traffic overloads the queue.                                                                                                                                                                |
| SNMP RX Queuing Redesign | Cisco IOS XE Dublin 17.12.1x   | <p>In previous releases, SNMP RX Queuing could impact AOM to CPP downloads, resulting in slow response to changing cable conditions.</p> <p>In this release, the new design fixes these issues. SNMP RX Queuing is more responsive to cable modem flaps, more responsive to resiliency changes of bandwidth on a link in response to impairments, and so on, while using the SNMP RX queue with saturating SNMP traffic.</p> |

Spike in SNMP traffic leads to drops in punt-path-rate-limiting (PPRL). Cisco IOS XE Bengaluru 17.6.1a release introduces a Control Plane Policing queue to shape incoming SNMP traffic. It reduces the need for the SNMP poller to retransmit the polling request in case the request is dropped when SNMP traffic overloads the queue.

This feature is disabled by default. Use the following command to configure this feature:

```
cable rxq snmp rate packets-per-second qlimit packets [avg-pkt-size bytes]
```

For example:

```
Router(config)#cable rxq snmp rate 1024 qlimit 8192 avg-pkt-size 1500
Router(config)#end
```

The SNMP packet rate range is 64–1024 packet/second. The queue limit range is 64–8192 packets. The average packet size range is 95–1500 bytes, the default size is 128 bytes.



**Note** The RXQ rate must be smaller than the punt-policer rate, so that RXQ handles the rate-limiting of SNMP packets.

When you update the RXQ parameters, the existing queue must be empty. It results in a delay before the new queue parameters take effect.

To verify the SNMP RX queuing configuration, use the **show** command as shown in the following examples:

```
Router#show platform hardware qfp active feature docsis rxq idx 1
Idx  Uidb          Qid          Rate(Kbps)  Qlmt(Byte)
1  0x0003ed92      0x0000b3a0   12288      12288000
```

```
Router#show plat hard qfp active infra bqs queue output default interface-string RXQ0
Interface: RXQ0 QFP: 0.0 if_h: 4718 Num Queues/Schedules: 1
Queue specifics:
  Index 0 (Queue ID:0xb3a0, Name: )
  Software Control Info:
    (cache) queue id: 0x0000b3a0, wred: 0x52783200, qlimit (bytes): 12288000
    parent_sid: 0x29e23, debug_name:
    sw_flags: 0x48000011, sw_state: 0x00000801, port_uidb: 257426
    orig_min   : 0                , min: 1228800
    min_qos    : 0                , min_dflt: 0
    orig_max   : 0                , max: 0
    max_qos    : 0                , max_dflt: 0
    share      : 1
    plevel     : 0, priority: 65535
    defer_obj_refcnt: 0, cp_ppe_addr: 0x00000000
  Statistics:
    tail drops (bytes): 115203800 , (packets): 525349
    total enqs (bytes): 208955400 , (packets): 1131326
    queue_depth (bytes): 0
    licensed throughput oversubscription drops:
      (bytes): 0 , (packets): 0
```

### Feature Restrictions

Starting with Cisco IOS XE Dublin 17.12.1x, the updated design for SNMP RX Queuing does not cause issues with AOM to CPP downloads. However, three features are affected by this design change:

- **Per-interface punt-policer:**

The punt-policer can be configured on a per-interface basis. This is in addition to the regular global punt-policer. However, RXQ processing runs in parallel to the per-interface punt-policer. Therefore, SNMP packets that go through RXQ bypasses the per-interface punt-policer.

- **Embedded Packet Capture (EPC) debugging:**

Egress EPC processing on the control-plane interface is performed before RXQ processing. This means that EPC captures packets that may be subsequently dropped by RXQ.

- **Packet-tracing debugging**

Packet-tracing information is not maintained as the packet traverses RXQ. So, if the packet is dropped, the expected output is seen in the packet-tracing output. If the packet successfully goes through RXQ and continues along the punt-path, packet-tracing shows the packet as being 'consumed', and no data after RXQ is recorded.

## Configuring Punt Policing

The punt policer aggregates all packets (both subscriber-side and WAN-side) with the specified punt cause, and rate-limits them according to the configured parameters.

### Procedure

|        | Command or Action                                                                                                                                                                   | Purpose                                                                                                                                                                                                                                                                                                                                                                                                                                               |
|--------|-------------------------------------------------------------------------------------------------------------------------------------------------------------------------------------|-------------------------------------------------------------------------------------------------------------------------------------------------------------------------------------------------------------------------------------------------------------------------------------------------------------------------------------------------------------------------------------------------------------------------------------------------------|
| Step 1 | <b>enable</b><br><b>Example:</b><br>Router> <b>enable</b>                                                                                                                           | Enables privileged EXEC mode. <ul style="list-style-type: none"> <li>• Enter your password, if prompted.</li> </ul>                                                                                                                                                                                                                                                                                                                                   |
| Step 2 | <b>configure terminal</b><br><b>Example:</b><br>Router# <b>configure terminal</b>                                                                                                   | Enters global configuration mode.                                                                                                                                                                                                                                                                                                                                                                                                                     |
| Step 3 | <b>platform punt-policer</b> { <b>cable-snmpp</b>   <i>punt-cause</i> }<br><i>punt-rate</i> [ <b>high</b> ]<br><b>Example:</b><br>Router(config)# <b>platform punt-policer 1 10</b> | Configures punt policing. <ul style="list-style-type: none"> <li>• <i>punt-cause</i>—Specifies the punt cause value.</li> <li>• <b>cable-snmpp</b>—This is the punt-cause assigned to SNMP packets destined to the CMTS.</li> <li>• <i>punt-rate</i>—Specifies the rate in packets/second. The range is from 10 to 300000.</li> <li>• <b>high</b>—(Optional) Specifies that the punt policing is performed only for high priority traffic.</li> </ul> |

## Verifying the Source-Based Rate Limit Configuration

- **show cable dp sbrl config**—Displays the SBRL configuration, including default settings. This is equivalent to **show running-config all | include punt-sbrl**.

Following is a sample output of the command:

```

Router# show cable dp sbrl config
platform punt-sbri wan punt-cause for-us-data rate-per-1-sec 8
platform punt-sbri wan punt-cause glean-adj rate-per-1-sec 4 quarantine-time 10
burst-factor 1000
platform punt-sbri subscriber punt-cause for-us-data rate-per-4-sec 32 bucket-size 32
platform punt-sbri subscriber punt-cause for-us-ctrl rate-per-4-sec 8 bucket-size 8
platform punt-sbri subscriber punt-cause cable-l3-mobility rate-per-4-sec 16 bucket-size
  16
platform punt-sbri subscriber punt-cause sv-match-unknown rate-per-4-sec 4 bucket-size
  4
platform punt-sbri subscriber punt-cause cable-pre-reg rate-per-4-sec 8 bucket-size 8
platform punt-sbri subscriber punt-cause cbl-dhcpv6-solicit rate-per-4-sec 8 bucket-size
  8
platform punt-sbri subscriber punt-cause cbl-dhcpv6-req rate-per-4-sec 8 bucket-size 8
platform punt-sbri subscriber punt-cause cbl-dhcpv6-sub rate-per-4-sec 8 bucket-size 8
platform punt-sbri subscriber punt-cause cbl-dhcpv4-sub rate-per-4-sec 8 bucket-size 8
platform punt-sbri subscriber punt-cause cbl-dhcpv4-disc-req rate-per-4-sec 8 bucket-size
  8

```

- **show access-lists**—Displays the access list information for verifying CoPP configuration.

Following is a sample output of the command:

```

Router# show access-lists

Extended IP access list 120
  10 permit ip any any dscp af31
  20 permit ip any any dscp cs2
  30 permit ip any any dscp af21
  40 permit ip 68.86.0.0 0.1.255.255 any
IPv6 access list TRUSTEDV6
  permit ipv6 2001:558::/32 any sequence 10

```

- **show policy-map *policy-map-name***—Displays the information for the policy map.

Following is a sample output of the command:

```

Router# show policy-map copp_policy

Policy Map copp_policy
Class sbri_trusted
  police rate 1000 pps
    conform-action transmit
    exceed-action transmit
Class class-default
  set qos-group 99

```

- **show policy-map control-plane**—Displays the control plane policy map information.

Following is a sample output of the command:

```

Router# show policy-map control-plane

Control Plane

Service-policy input: copp_policy

Class-map: sbri_trusted (match-any)
  0 packets, 0 bytes
  5 minute offered rate 0000 bps, drop rate 0000 bps
Match: access-group 120
Match: access-group name TRUSTEDV6
police:
  rate 1000 pps, burst 244 packets

```

```

conformed 0 packets, 0 bytes; actions:
  transmit
exceeded 0 packets, 0 bytes; actions:
  transmit
conformed 0 pps, exceeded 0 pps

Class-map: class-default (match-any)
  28 packets, 4364 bytes
  5 minute offered rate 0000 bps, drop rate 0000 bps
Match: any
QoS Set
  qos-group 99
  Marker statistics: Disabled

```

- **show platform hardware qfp active infrastructure punt sbrl**—Displays the SBRL statistics.

Following is a sample output of the command:

```

Router# show platform hardware qfp active infrastructure punt sbrl

SBRL statistics

Subscriber MAC-addr
  drop-cnt  evict-cnt  quar  MAC-Address      ID  punt-cause
-----
          10000      10000      0  0010.88a3.0456  101  cable-13-mobility

WAN-IPv4
  drop-cnt  evict-cnt  quar  VRF  cause  IP-address
-----
    456788    456788      0    0    050   1.2.0.66

WAN-IPv6
  drop-cnt  evict-cnt  quar  VRF  cause  IP-address
-----
    129334    129334      1    0    011   3046:1829:fefb::ddd1
         965         965      0    0    011   2001:420:2c7f:fc01::3

. . .

```



**Note** The value of *quar* is either 0 or 1. The value 1 indicates that quarantine is activated.



**Note** The SBRL statistics algorithm stores the data for the worst offenders. Sources that drop only a few packets are displayed in the table initially, but may be overwritten if the *drop-cnt* does not increase continuously. The *evict-cnt* increases in tandem with *drop-cnt*, but begins to decrease when a source is no longer being actively rate-limited. When the *evict-cnt* drops below 10, the record may be overwritten.

- **show platform hardware qfp active infrastructure punt statistics type global-drop**—Displays the global punt policer statistics.

Following is a sample output of the command:

```
Router# show platform hardware qfp active infrastructure punt statistics type global-drop
```

Global Drop Statistics

Number of global drop counters = 22

| Counter ID | Drop Counter Name                       | Packets |
|------------|-----------------------------------------|---------|
| 000        | INVALID_COUNTER_SELECTED                | 0       |
| 001        | INIT_PUNT_INVALID_PUNT_MODE             | 0       |
| 002        | INIT_PUNT_INVALID_PUNT_CAUSE            | 0       |
| 003        | INIT_PUNT_INVALID_INJECT_CAUSE          | 0       |
| 004        | INIT_PUNT_MISSING_FEATURE_HDR_CALLBACK  | 0       |
| 005        | INIT_PUNT_EXT_PATH_VECTOR_REQUIRED      | 0       |
| 006        | INIT_PUNT_EXT_PATH_VECTOR_NOT_SUPPORTED | 0       |
| 007        | INIT_INJ_INVALID_INJECT_CAUSE           | 0       |
| 008        | INIT_INJ_MISSING_FEATURE_HDR_CALLBACK   | 0       |
| 009        | PUNT_INVALID_PUNT_CAUSE                 | 0       |
| 010        | PUNT_INVALID_COMMON_HDR_VERSION         | 0       |
| 011        | PUNT_INVALID_PLATFORM_HDR_VERSION       | 0       |
| 012        | PUNT_PATH_NOT_INITIALIZED               | 0       |
| 013        | PUNT_GPM_ALLOC_FAILURE                  | 0       |
| 014        | PUNT_TRANSITION_FAILURE                 | 0       |
| 015        | PUNT_DELAYED_PUNT_PKT_SB_NOT_IN_USE     | 0       |
| 016        | PUNT_CAUSE_GLOBAL_POLICER               | 0       |
| 017        | INJ_INVALID_INJECT_CAUSE                | 0       |
| 018        | INJ_INVALID_COMMON_HDR_VERSION          | 0       |
| 019        | INJ_INVALID_PLATFORM_HDR_VERSION        | 0       |
| 020        | INJ_INVALID_PAL_HDR_FORMAT              | 0       |
| 021        | PUNT_GPM_TX_LEN_EXCEED                  | 0       |

- **show platform hardware qfp active infrastructure punt summary [threshold threshold-value]**—Displays the punt path rate-limiting summary.

Following is a sample output of the command:

```
Router# show platform hardware qfp active infrastructure punt summary
```

Punt Path Rate-Limiting summary statistics

| Subscriber-side |                     |          |      |              |             |          |        |       |
|-----------------|---------------------|----------|------|--------------|-------------|----------|--------|-------|
| ID              | punt-cause-str      | CPP-punt | CoPP | ARPFilt-SBRL | RXQ-ARPauto | punt-pol | global | to-RP |
| 157             | cable-snmp          | 49320    | 0    | 0            | 23154       | 0        | 0      | 26166 |
| 135             | cbl-dhcpv4-disc-req | 29       | 0    | 0            | 0           | 0        | 0      | 9     |
| 119             | cbl-dhcpv6-req      | 2        | 0    | 0            | 0           | 0        | 0      | 2     |
| 118             | cbl-dhcpv6-solicit  | 13       | 0    | 0            | 0           | 0        | 0      | 13    |
| 103             | cable-pre-reg       | 4        | 0    | 0            | 0           | 0        | 0      | 4     |
| 055             | for-us-ctrl         | 27       | 0    | 0            | 0           | 0        | 0      | 27    |
| 011             | for-us-data         | 10       | 0    | 0            | 0           | 0        | 0      | 10    |
| 010             | incomplete-adj      | 22       | 0    | 0            | 0           | 0        | 0      | 22    |

| WAN-side |                      |          |      |      |     |          |        |       |
|----------|----------------------|----------|------|------|-----|----------|--------|-------|
| ID       | punt-cause-str       | CPP-punt | CoPP | SBRL | RXQ | punt-pol | global | to-RP |
| 168      | cable-snmp-rxq       | 26166    | 0    | 0    | 0   | 0        | 0      | 0     |
| 107      | cable-dhcp           | 44       | 0    | 0    | 0   | 0        | 0      | 44    |
| 056      | for-us-internal-ctrl | 1        | 0    | 0    | 0   | 0        | 0      | 1     |
| 055      | for-us-ctrl          | 418      | 0    | 0    | 0   | 0        | 0      | 418   |
| 021      | diag                 | 310      | 0    | 0    | 0   | 0        | 0      | 310   |
| 011      | for-us-data          | 69       | 0    | 0    | 0   | 0        | 0      | 69    |
| 010      | incomplete-adj       | 23       | 0    | 0    | 0   | 0        | 0      | 23    |



```

007 arp                1      0      0      0      0      0      1
003 unknown-encap     369    0      0      0      0      0      369

```

- **show platform software punt-policer**—Displays the punt policer configuration and statistics.

Following is a sample output of the command:

```
Router# show platform software punt-policer
```

Per Punt-Cause Policer Configuration and Packet Counters

| Punt Cause | Description                  | Configured (pps) |       | Conform Packets |       | Dropped Packets |      |
|------------|------------------------------|------------------|-------|-----------------|-------|-----------------|------|
|            |                              | Normal           | High  | Normal          | High  | Normal          | High |
| 2          | IPv4 Options                 | 4000             | 3000  | 0               | 0     | 0               | 0    |
| 3          | Layer2 control and legacy    | 40000            | 10000 | 16038           | 0     | 0               | 0    |
| 4          | PPP Control                  | 2000             | 1000  | 0               | 0     | 0               | 0    |
| 5          | CLNS IS-IS Control           | 2000             | 1000  | 0               | 0     | 0               | 0    |
| 6          | HDLc keepalives              | 2000             | 1000  | 0               | 0     | 0               | 0    |
| 7          | ARP request or response      | 2000             | 1000  | 0               | 49165 | 0               | 0    |
| 8          | Reverse ARP request or re... | 2000             | 1000  | 0               | 0     | 0               | 0    |
| 9          | Frame-relay LMI Control      | 2000             | 1000  | 0               | 0     | 0               | 0    |
| 10         | Incomplete adjacency         | 2000             | 1000  | 0               | 0     | 0               | 0    |
| 11         | For-us data                  | 40000            | 5000  | 279977          | 0     | 0               | 0    |
| 12         | Mcast Directly Connected ... | 2000             | 1000  | 0               | 0     | 0               | 0    |

- **show platform hardware qfp active infrastructure punt policer summary**—Displays the punt policer summary.

Following is a sample output of the command:

```
Router# show platform hardware qfp active infrastructure punt policer summary
```

QFP Punt Policer Config Summary

| Policer Handle | Rate (pps) | PeakRate (pps) | ConformBurst (pps) | ExceedBurst (pps) | Scaling Factor |
|----------------|------------|----------------|--------------------|-------------------|----------------|
| 001            | 300000     | 0              | 2288               | 2288              | 0              |
| 002            | 4000       | 0              | 4000               | 0                 | 0              |
| 003            | 3000       | 0              | 3000               | 0                 | 0              |
| 004            | 40000      | 0              | 40000              | 0                 | 0              |
| 005            | 10000      | 0              | 10000              | 0                 | 0              |
| 006            | 2000       | 0              | 2000               | 0                 | 0              |
| 007            | 1000       | 0              | 1000               | 0                 | 0              |
| 008            | 2000       | 0              | 2000               | 0                 | 0              |
| 009            | 1000       | 0              | 1000               | 0                 | 0              |
| 010            | 2000       | 0              | 2000               | 0                 | 0              |
| 011            | 1000       | 0              | 1000               | 0                 | 0              |
| 012            | 2000       | 0              | 2000               | 0                 | 0              |
| 013            | 1000       | 0              | 1000               | 0                 | 0              |
| 014            | 2000       | 0              | 2000               | 0                 | 0              |

# Configuration Examples for Source-Based Rate Limit

The following sample configurations are examples for Source-Based Rate Limit Configuration.

## Example: Subscriber-Side SBRL Configuration

```
platform punt-sbri subscriber punt-cause cbl-dhcpv6-solicit rate-per-4-sec 2 bucket-size 8
platform punt-sbri subscriber punt-cause sv-match-unknown rate-per-4-sec 4 bucket-size 10
quarantine-time 5 burst-factor 500
```

## WAN Side Source-Based Rate Limit

WAN-side SBRL is enabled through CoPP. CoPP is used to specify which WAN-side packet streams are directed to WAN-side SBRL, using the **set qos-group 99** command. This means that in cBR-8, **qos-group 99** is globally reserved for SBRL, and cannot be otherwise used.

In the examples below, WAN-side punts matching the trusted classes bypass WAN-side SBRL. WAN-side punts that end up in the **default-class** are sent to WAN-side SBRL.

## Configuring Control Plane Policing for Releases Before Cisco IOS XE Cupertino 17.9.1w

### Example 1: WAN-Side SBRL Configuration

```
access-list 120 permit ip any any dscp af31
access-list 120 permit ip any any dscp cs2
access-list 120 permit ip any any dscp af21
access-list 120 permit ip 192.168.1.10 0.1.255.255 any

ipv6 access-list TRUSTEDV6
  permit ipv6 any any dscp af31
  permit ipv6 any any dscp cs2
  permit ipv6 any any dscp af21
  permit ipv6 2001:558::/32 any

class-map match-all sbri_trusted_v4
  match access-group 120

class-map match-all sbri_trusted_v6
  match access-group name TRUSTEDV6

policy-map copp_policy
  ! IPv4 trusted:
  !   Specified rate is irrelevant.
  !   No special action; these packets bypass WAN-side SBRL.
  class sbri_trusted_v4
    police rate 1000 pps conform transmit exceed transmit
  ! IPv6 trusted:
  !   Specified rate is irrelevant.
  !   No special action; these packets bypass WAN-side SBRL.
  class sbri_trusted_v6
    police rate 1000 pps conform transmit exceed transmit

  ! add other classes here, if necessary

  ! Special action to activate WAN-side SBRL for this class.
```

```

class class-default
  set qos-group 99

control-plane
  service-policy input copp_policy

platform punt-sbri wan punt-cause for-us-data rate-per-1-sec 4
platform punt-sbri wan punt-cause glean-adj rate-per-1-sec 4 quarantine-time 10 burst-factor
1000

```

### Example 2: WAN-Side SBRL Configuration

The following example shows a simple CoPP configuration which sends traffic to WAN-side SBRL, and also demonstrates how trusted and untrusted traffic is specified. CoPP applies to all punted packets, so it is necessary to ensure that the trusted/untrusted configuration does not interfere with cable-side packets.



---

**Note** All ACLs used by CoPP should be configured to 'permit' packets, even for packet streams that are untrusted.

---

```

! trusted packets
access-list 120 permit ip 192.168.1.10 0.0.0.0 any tos 2

! untrusted packets
access-list 130 permit ip 192.168.1.10 0 0 0 0 any tos 4

class-map match-any SBRL_TRUSTED
  match access-group 120

class-map match-any SBRL_UNTRUSTED
  match access-group 130

policy-map COPP_POLICY
  class SBRL_TRUSTED
    ! the specified rate is irrelevant
    ! no special action, so these packets bypass SBRL
    police rate 1000 pps conform transmit exceed transmit

  class SBRL_UNTRUSTED
    ! the specified rate is irrelevant
    ! these packets are all dropped
    police rate 1000 pps conform drop exceed drop

  << other classes, if necessary >>

class class-default
  ! special action to activate WAN-side SBRL for this class
  set qos-group 99

control-plane
  service-policy input COPP_POLICY

```

### Configuring Control Plane Policing for Cisco IOS XE Cupertino 17.9.1w and Later

Starting with Cisco IOS XE Cupertino 17.9.1w, the **punt-path** is modified to set **qos-group** in context to **99** for **subscriber-side punts**, which is the qos-group that is reserved for SBRL.

This allows configuration of a class-map in CoPP to identify subscriber-side punts. Subscriber-side punts can effectively 'bypass' CoPP. The CoPP policy can then be simplified, because it does not interfere with subscriber-side punts. All subscriber-side punts are still subject to subscriber-side SBRL, so there is no security issue. The previous example is modified, and shown below:

```
! trusted packets
access-list 120 permit ip 192.168.1.10 0.0.0.0 any tos 2

! untrusted packets
access-list 130 permit ip 192.168.1.10 0 0 0 0 any tos 4

class-map match-any SBRL_TRUSTED
  match access-group 120

class-map match-any SBRL_UNTRUSTED
  match access-group 130

class-map match-any SUBSCRIBER_SIDE
  match qos-group 99

policy-map COPP_POLICY
  class SUBSCRIBER_SIDE
    ! the specified rate is irrelevant
    ! these packets go to subscriber-side SBRL
    police rate 1000 pps conform-action transmit exceed-action transmit

  class SBRL_TRUSTED
    ! the specified rate is irrelevant
    ! no special action, so these packets bypass SBRL
    police rate 1000 pps conform transmit exceed transmit

  class SBRL_UNTRUSTED
    ! the specified rate is irrelevant
    ! these packets are all dropped
    police rate 1000 pps conform drop exceed drop

  << other classes, if necessary >>

class class-default
  ! special action to activate WAN-side SBRL for this class
  set qos-group 99

control-plane
  service-policy input COPP_POLICY
```

## Default SBRL Configuration

Because of the dependency on CoPP, WAN-side SBRL is disabled by default. There is no default WAN-side SBRL configuration.

Subscriber-side SBRL has the following default settings:

```
platform punt-sbri subscriber punt-cause for-us-data rate-per-4-sec 32 bucket-size 32
platform punt-sbri subscriber punt-cause for-us-ctrl rate-per-4-sec 8 bucket-size 8
platform punt-sbri subscriber punt-cause cable-l3-mobility rate-per-4-sec 16 bucket-size 16
platform punt-sbri subscriber punt-cause sv-match-unknown rate-per-4-sec 4 bucket-size 4
platform punt-sbri subscriber punt-cause cable-pre-reg rate-per-4-sec 8 bucket-size 8
platform punt-sbri subscriber punt-cause cbl-dhcpv6-solicit rate-per-4-sec 8 bucket-size 8
platform punt-sbri subscriber punt-cause cbl-dhcpv6-req rate-per-4-sec 8 bucket-size 8
```

```
platform punt-sbri subscriber punt-cause cbl-dhcpv6-sub rate-per-4-sec 8 bucket-size 8
platform punt-sbri subscriber punt-cause cbl-dhcpv4-disc-req rate-per-4-sec 8 bucket-size 8
platform punt-sbri subscriber punt-cause cbl-dhcpv4-sub rate-per-4-sec 8 bucket-size 8
```

## Conversion of SBRL Subscriber-side Configuration from 16.8.x to 16.9.x

In 16.9.x, several new punt-causes were added for DHCP packets on the subscriber-side. This means that the recommended configuration for 16.8.x does not match up with the default configuration in 16.9.x.

In 16.8.x, the cable-dhcp punt-cause is used by both subscriber-side and WAN-side DHCP punts. In 16.9.x, new punt-causes were added on the subscriber-side for DHCP packets, with the result that the cable-dhcp punt-cause is used ONLY for WAN-side DHCP punts. This means that configuring a rate for cable-dhcp on the subscriber-side is meaningless. The chart below shows the DHCP-related punt-causes for 16.8.x and 16.9.x. In 16.9.x, all the subscriber-side DHCP punt-causes have default SBRL settings.

**Table 318: 16.8.x**

| punt-cause         | Origin  | Description            |
|--------------------|---------|------------------------|
| cbl-dhcpv6-solicit | sub     | DHCPv6 solicit         |
| cbl-dhcpv6-req     | sub     | DHCPv6 request         |
| cable-dhcp         | sub/WAN | all other DHCP packets |

**Table 319: 16.9.x**

| punt-cause          | Origin | Description                         |
|---------------------|--------|-------------------------------------|
| cbl-dhcpv6-solicit  | sub    | DHCPv6 solicit                      |
| cbl-dhcpv6-req      | sub    | DHCPv6 request                      |
| cbl-dhcpv6-sub      | sub    | all other (sub-side) DHCPv6 packets |
| cbl-dhcpv4-disc-req | sub    | DHCPv4 discover & request           |
| cbl-dhcpv4-sub      | sub    | all other (sub-side) DHCPv4 packets |
| cable-dhcp          | WAN    | all (WAN-side) DHCP packets         |

# Conversion of Divert Rate Limit Configuration on the Cisco uBR10012 Router to SBRL Configuration on the Cisco cBR Series Routers

## Divert Rate Limit Configuration on the Cisco uBR10012 Router

The following is a sample Divert Rate Limit (DRL) configuration on the Cisco uBR10012 router:

```

service divert-rate-limit ip fib_rp_glean rate 4 limit 4
service divert-rate-limit ip fib_rp_dest rate 4 limit 4
service divert-rate-limit ip fib_rp_punt rate 4 limit 4
service divert-rate-limit ipv6 ipv6_rp_dest rate 4 limit 4
service divert-rate-limit ipv6 ipv6_rp_punt rate 4 limit 4
service divert-rate-limit ipv6 ipv6_rp_glean rate 4 limit 4
service divert-rate-limit ipv6 icmpv6 rate 4 limit 4

service divert-rate-limit trusted-site 0.0.0.0 0.0.0.0 tos 0x68 mask 0xFF
service divert-rate-limit trusted-site 0.0.0.0 0.0.0.0 tos 0x40 mask 0xFF
service divert-rate-limit trusted-site 68.86.0.0 255.254.0.0 tos 0x0 mask 0x0
service divert-rate-limit trusted-site 0.0.0.0 0.0.0.0 tos 0x48 mask 0xFF
service divert-rate-limit trusted-site-ipv6 ::/0 traffic-class 0x40 mask 0xFF
service divert-rate-limit trusted-site-ipv6 ::/0 traffic-class 0x48 mask 0xFF
service divert-rate-limit trusted-site-ipv6 ::/0 traffic-class 0x68 mask 0xFF
service divert-rate-limit trusted-site-ipv6 2001:558::/32 traffic-class 0x0 mask 0x0

interface Cabledx/y/z
  cable divert-rate-limit rate 4 limit 30

```

In Cisco IOS Release 12.2(33)SCH2, the **divert-rate-limit max-rate wan** command was introduced on the Cisco uBR10012 router. This configuration limits the aggregate rate of diverted packets on the WAN-side, on a per-divert-code basis. The following is the recommended best-practice configuration for the **divert-rate-limit max-rate wan** command:

```

service divert-rate-limit max-rate wan fib_rp_glean rate 5000
service divert-rate-limit max-rate wan fib_rp_punt rate 5000
service divert-rate-limit max-rate wan fib_rp_dest rate 40000

service divert-rate-limit max-rate wan ipv6_fib_glean rate 5000
service divert-rate-limit max-rate wan ipv6_fib_punt rate 5000
service divert-rate-limit max-rate wan ipv6_fib_dest rate 40000

```

## SBRL Configuration on the Cisco cBR Series Routers

The DRL functionality is called as Source-Based Rate Limit (SBRL) on the Cisco cBR Series Routers. The punt-path has three layers of protection:

- [CoPP, on page 1619](#)
- [SBRL, on page 1619](#)
- [Punt Policer, on page 1620](#)

## CoPP

CoPP is used to specify the trusted sites and activate WAN-side SBRL. However, since CoPP applies to all punted packets, you must ensure that cable-side punts do not match the trusted sites.

The following is a sample CoPP configuration, which is equivalent to the configuration on the Cisco uBR10012 router:

```
access-list 120 permit ip any any dscp af31
access-list 120 permit ip any any dscp cs2
access-list 120 permit ip any any dscp af21
access-list 120 permit ip 68.86.0.0 0.1.255.255 any

ipv6 access-list TRUSTEDV6
  permit ipv6 any any dscp af31
  permit ipv6 any any dscp cs2
  permit ipv6 any any dscp af21
  permit ipv6 2001:558::/32 any

class-map match-all sbrl_trusted_v4
  match access-group 120

class-map match-all sbrl_trusted_v6
  match access-group name TRUSTEDV6

policy-map copp_policy
  class sbrl_trusted_v4
    police rate 1000 pps conform transmit exceed transmit
  class sbrl_trusted_v6
    police rate 1000 pps conform transmit exceed transmit
  class class-default
    set qos-group 99

control-plane
  service-policy input copp_policy
```



- 
- Note**
- The **set qos-group 99** command activates SBRL for the specified class.
  - The police rate for **sbrl\_trusted\_vx** is irrelevant, as both actions are set to **transmit**.
  - You can add other trusted sites, as necessary.
- 

## SBRL

The following subscriber-side SBRL configuration is recommended. This configuration covers the expected subscriber-side punt-causes.

```
platform punt-sbri subscriber punt-cause for-us-data rate-per-4-sec 32
platform punt-sbri subscriber punt-cause for-us-ctrl rate-per-4-sec 8
platform punt-sbri subscriber punt-cause sv-match-unknown rate-per-4-sec 4
platform punt-sbri subscriber punt-cause cable-pre-reg rate-per-4-sec 8
platform punt-sbri subscriber punt-cause cable-dhcp rate-per-4-sec 8
platform punt-sbri subscriber punt-cause cbl-dhcpv6-solicit rate-per-4-sec 8
platform punt-sbri subscriber punt-cause cbl-dhcpv6-req rate-per-4-sec 8
```

The recommended subscriber-side SBRL configuration is the default configuration. All expected subscriber-side punt-causes have default settings.

For WAN-side SBRL, the Cisco cBR Series routers do not have separate IPv4 and IPv6 configurations as the punt causes are shared between IPv4 and IPv6. The *limit* cannot be configured as the hardware policer is used. Therefore, we recommend that you configure a higher *rate* initially. In the following sample configuration, *glean-adj* and *for-us-data* correspond to **x\_rp\_glean** and **x\_rp\_dest**, respectively on the Cisco uBR 10012 router.

```
platform punt-sbri wan punt-cause for-us-data rate 8
platform punt-sbri wan punt-cause glean-adj rate 8
```



#### Note

- The *fib-punt* punt cause is used in the Cisco uBR10012 router for packets destined to the management Ethernet. This punt cause is not used on the Cisco cBR Series routers.
- The Cisco cBR Series routers do not have an equivalent punt cause for ICMPV6. In the Cisco uBR10012 routers, ICMPv6 packets must be processed by the Route Processor to generate the checksum. In the Cisco cBR Series routers, ICMPv6 is processed in the control-plane. However, ICMPv6 punts can be identified and rate-limited (in aggregate) using CoPP.

### Punt Policer

The punt policer operates on all punt causes and is fully configurable. The punt policer is not divided into WAN-side and subscriber-side. All packets with a given punt cause are aggregated and rate-limited as configured.

Following are the default settings (best-practice configuration) for the punt policer on the Cisco cBR Series routers:

| punt-cause               | LO    | HI   |
|--------------------------|-------|------|
| CPP_PUNT_CAUSE_GLEAN_ADJ | 2000  | 5000 |
| CPP_PUNT_CAUSE_FOR_US    | 40000 | 5000 |



#### Note

- The equivalent punt cause for *fib-glean* (on the Cisco uBR10012 router) is *GLEAN\_ADJ/HI* on the Cisco cBR Series routers.
- The equivalent punt cause for *fib-dest* (on the Cisco uBR10012 router) is *FOR\_US/LO* on the Cisco cBR Series routers.



## Additional References

### Technical Assistance

| Description                                                                                                                                                                                                                                                                                                                                                                                                                                                                                                                                                             | Link                                                                    |
|-------------------------------------------------------------------------------------------------------------------------------------------------------------------------------------------------------------------------------------------------------------------------------------------------------------------------------------------------------------------------------------------------------------------------------------------------------------------------------------------------------------------------------------------------------------------------|-------------------------------------------------------------------------|
| <p>The Cisco Support website provides extensive online resources, including documentation and tools for troubleshooting and resolving technical issues with Cisco products and technologies.</p> <p>To receive security and technical information about your products, you can subscribe to various services, such as the Product Alert Tool (accessed from Field Notices), the Cisco Technical Services Newsletter, and Really Simple Syndication (RSS) Feeds.</p> <p>Access to most tools on the Cisco Support website requires a Cisco.com user ID and password.</p> | <a href="http://www.cisco.com/support">http://www.cisco.com/support</a> |

## Feature Information for Source-Based Rate Limit

Use Cisco Feature Navigator to find information about the platform support and software image support. Cisco Feature Navigator enables you to determine which software images support a specific software release, feature set, or platform. To access Cisco Feature Navigator, go to the <https://cfng.cisco.com/> link. An account on the Cisco.com page is not required.



**Note** The following table lists the software release in which a given feature is introduced. Unless noted otherwise, subsequent releases of that software release train also support that feature.

*Table 320: Feature Information for Source-Based Rate Limit*

| Feature Name            | Releases                         | Feature Information                                                                                               |
|-------------------------|----------------------------------|-------------------------------------------------------------------------------------------------------------------|
| Source-based rate limit | Cisco IOS XE Everest 16.6.1      | This feature was integrated into Cisco IOS XE Everest 16.6.1 on the Cisco cBR Series Converged Broadband Routers. |
| Source-based rate limit | Cisco IOS XE Gibraltar 16.12.1z1 | A new punt cause <b>cable-snmp</b> was added to rate-limit the SNMP packets destined to the CMTS.                 |





## CHAPTER 102

# Cable Duplicate MAC Address Reject

The Cable Duplicate MAC Address Reject feature is a DOCSIS 1.1-compliant security enhancement that helps to eliminate denial-of-service (DOS) attacks that are caused by cloned cable modems. A clone is presumed to be one of two physical cable modems on the same Cisco CMTS router with the same HFC interface MAC address. The cloned cable modem may be DOCSIS 1.0 or later, and may be semi-compliant or non-compliant with portions of the DOCSIS specifications.

Your software release may not support all the features that are documented in this module. For the latest feature information and caveats, see the release notes for your platform and software release. The Feature Information Table at the end of this document provides information about the documented features and lists the releases in which each feature is supported.

Use Cisco Feature Navigator to find information about platform support and Cisco software image support. To access Cisco Feature Navigator, go to <http://tools.cisco.com/ITDIT/CFN/>. An account on <http://www.cisco.com/> is not required.

### Contents

- [Hardware Compatibility Matrix for the Cisco cBR Series Routers, on page 1623](#)
- [Prerequisites for Cable Duplicate MAC Address Reject, on page 1625](#)
- [Restrictions for Cable Duplicate MAC Address Reject, on page 1625](#)
- [Information About Cable Duplicate MAC Address Reject, on page 1625](#)
- [How to Configure EAE and BPI+ Enforcement Features, on page 1628](#)
- [Configuration Example for EAE and BPI+ Enforcement Policies, on page 1631](#)
- [Verifying EAE and BPI+ Enforcement Policies, on page 1631](#)
- [System Messages Supporting Cable Duplicate MAC Address Reject, on page 1632](#)
- [Additional References, on page 1633](#)
- [Feature Information for Cable Duplicate MAC Address Reject, on page 1633](#)

## Hardware Compatibility Matrix for the Cisco cBR Series Routers



**Note** The hardware components that are introduced in a given Cisco IOS-XE Release are supported in all subsequent releases unless otherwise specified.

Table 321: Hardware Compatibility Matrix for the Cisco cBR Series Routers

| Cisco CMTS Platform                    | Processor Engine                                                                                                                                                                                  | Interface Cards                                                                                                                                                                                                                                                                                                                                                                                                                                                                                                                                                                                                                                                                                                                                                                                 |
|----------------------------------------|---------------------------------------------------------------------------------------------------------------------------------------------------------------------------------------------------|-------------------------------------------------------------------------------------------------------------------------------------------------------------------------------------------------------------------------------------------------------------------------------------------------------------------------------------------------------------------------------------------------------------------------------------------------------------------------------------------------------------------------------------------------------------------------------------------------------------------------------------------------------------------------------------------------------------------------------------------------------------------------------------------------|
| Cisco cBR-8 Converged Broadband Router | <p><b>Cisco IOS-XE Release 16.5.1 and Later Releases</b></p> <p>Cisco cBR-8 Supervisor:</p> <ul style="list-style-type: none"> <li>• PID—CBR-SUP-250G</li> <li>• PID—CBR-CCAP-SUP-160G</li> </ul> | <p><b>Cisco IOS-XE Release 16.5.1 and Later Releases</b></p> <p>Cisco cBR-8 CCAP Line Cards:</p> <ul style="list-style-type: none"> <li>• PID—CBR-LC-8D30-16U30</li> <li>• PID—CBR-LC-8D31-16U30</li> <li>• PID—CBR-RF-PIC</li> <li>• PID—CBR-RF-PROT-PIC</li> <li>• PID—CBR-CCAP-LC-40G</li> <li>• PID—CBR-CCAP-LC-40G-R</li> <li>• PID—CBR-CCAP-LC-G2-R</li> <li>• PID—CBR-SUP-8X10G-PIC</li> <li>• PID—CBR-2X100G-PIC</li> </ul> <p>Digital PICs:</p> <ul style="list-style-type: none"> <li>• PID—CBR-DPIC-8X10G</li> <li>• PID—CBR-DPIC-2X100G</li> </ul> <p>Cisco cBR-8 Downstream PHY Module:</p> <ul style="list-style-type: none"> <li>• PID—CBR-D31-DS-MOD</li> </ul> <p>Cisco cBR-8 Upstream PHY Modules:</p> <ul style="list-style-type: none"> <li>• PID—CBR-D31-US-MOD</li> </ul> |



**Note** Do not use DPICs (8X10G and 2x100G) to forward IP traffic, as it may cause buffer exhaustion, leading to line card reload.

The only allowed traffic on a DPIC interface is DEPI, UEPI, and GCP traffic from the Cisco cBR-8 router to Remote PHY devices. Other traffic such as DHCP, SSH, and UTSC should flow via another router, since DPICs cannot be used for normal routing.

## Prerequisites for Cable Duplicate MAC Address Reject

The Cable Duplicate MAC Address Reject feature entails the following behaviors and prerequisites on the DOCSIS-compliant network:

- The Cisco CMTS router requires that the legitimate cable modem is Baseline Privacy Interface Plus (BPI+) compliant, meaning that it can come to one of the following four online states when provisioned with a DOCSIS configuration file containing at least one BPI+ related type, length, value (TLV). For brevity, this document refers to these states as online(p\_).
- The Cisco CMTS router gives priority to any cable modem that registers to the Cisco CMTS router in any of the following four states:
  - online(pt)
  - online(pk)
  - online(ptd)
  - online(pkd)

The Cisco CMTS router drops registration requests from another device that purports to use the same MAC address as an already operational modem that is in one of these four states.

[Hardware Compatibility Matrix for the Cisco cBR Series Routers, on page 39](#) shows the hardware compatibility prerequisites for this feature.



---

**Note** The hardware components introduced in a given Cisco IOS Release are supported in all subsequent releases unless otherwise specified.

---

## Restrictions for Cable Duplicate MAC Address Reject

- If the cable modem is not provisioned to use DOCSIS BPI+, as characterized by not coming online with the above initialization states of online(p\_), then the existing behavior of the Cisco CMTS router remains unchanged. The Cisco CMTS router does not attempt to distinguish between two cable modems if the provisioning system does not provide a DOCSIS configuration file specifying BPI+ be enabled.
- When this feature is enabled, the Cisco CMTS router issues security breach notice in a log message in the cable logging layer2events log, or the generic log if the **cable logging layer2events** command is not configured on the Cisco CMTS router.

## Information About Cable Duplicate MAC Address Reject

The Cable Duplicate MAC Address Reject feature is enabled by default on the Cisco CMTS router, and has no associated configuration commands. This feature creates a new log message, which appears in the system log by default.

This document also describes the following security features that are associated with the Cable Duplicate MAC Address Reject feature:

## Early Authentication and Encryption

The Early Authentication and Encryption (EAE) feature enables the Cisco CMTS router to authenticate DOCSIS 3.0 cable modems immediately after completion of the ranging process, and encrypt all of the registration packets including DHCP and TFTP traffic. This security feature, compatible only with DOCSIS 3.0 cable modems, was introduced to help multiple service operators (MSOs) prevent theft of service.

This feature is enabled only for cable modems that initialize on a downstream channel on which the Cisco CMTS router is transmitting MAC Domain Descriptor (MDD) messages. The Cisco CMTS router uses TLV type 6 in the MDD MAC message to signal EAE to a cable modem. If this feature is enabled, only the authenticated cable modems are allowed to continue their initialization process and subsequently admitted to the network. The early authentication and encryption process involves the following:

- Authentication of the cable modem (that is the BPI+ authorization exchanges) after the ranging process.
- Traffic encryption key (TEK) exchanges for the cable modem primary Security Association Identifier (SAID).
- Encryption of IP provisioning traffic and Multipart Registration Request (REG-REQ-MP) messages during cable modem initialization.

## EAE Enforcement Policies

The Cisco CMTS router supports the following EAE enforcement policies:

- No EAE enforcement (Policy 1)—EAE is disabled and the Cisco CMTS router cannot enforce EAE on any cable modem.
- Ranging-based EAE enforcement (Policy 2)—EAE is enforced on all DOCSIS 3.0 cable modems that range with a B-INIT-RNG-REQ MAC message.
- Capability-based EAE enforcement (Policy 3)—EAE is enforced on all DOCSIS 3.0 cable modems that range with a B-INIT-RNG-REQ MAC message in which the EAE capability flag is set using the .
- Total EAE enforcement (Policy 4)—EAE is enforced on all cable modems irrespective of the EAE capability flag status.

The EAE enforcement policies are mutually exclusive. By default, EAE is disabled on the Cisco CMTS router.

## EAE Exclusion

You can exclude cable modems from EAE enforcement using the **cable privacy eae-exclude** command in the global configuration mode. Cable modems in the EAE exclusion list are always exempted from EAE enforcement. You can remove cable modems from the exclusion list using the no form of the **cable privacy eae-exclude** command.

## BPI+ Security and Cloned Cable Modems

The BPI+ Security and Cloned Cable Modems feature prioritizes cable modems that are online with BPI+ security over new cable modem registration requests that use the same cable modem MAC address. As a result, the legitimate cable modem with BPI+ security certificates that match the HFC MAC address does not experience service disruption, even if a non-compliant cable modem with the same HFC MAC address attempt to register.

The cloned cable modem detection function requires that a cable modem use DOCSIS 1.1 or a later version and should be provisioned with BPI+ enabled. That is, one BPI+ type, length, value (TLV) must be included in the DOCSIS configuration file. All DOCSIS 1.0, DOCSIS 1.1, and later cable modems that are provisioned

without DOCSIS BPI+ enabled continue to use the legacy DOCSIS behavior, and experience a DoS attack when a cloned cable modem appears on the Cisco CMTS router.

This cloned cable modem detection function mandates that a cable modem provisioned with BPI+ and DOCSIS 1.1 QoS must register with BPI+ and not use BPI. The commonly available non-DOCSIS-compliant cable modems contain an option to force registration in BPI as opposed to BPI+ mode even when DOCSIS 1.1 QoS and BPI+ are specified in the DOCSIS configuration file.

## Logging of Cloned Cable Modems

Cloned cable modems are detected and tracked with system logging. The Logging of Cloned Cable Modem feature is enabled by default. Due to the large number of DOCSIS Layer 2 messages typically seen in a production network, a separate log is available to segregate these messages. By default, cloned cable modem messages are placed in the cable logger, cable layer2events logging. If you disable this feature using the no form of the **cable logging layer2events** command in global configuration mode, then the cloned cable modem messages are placed in the system log (syslog).

A cloned cable modem might attempt dozens of registration attempts in a short period of time. In order to suppress the number of log messages generated, the Cisco CMTS router suppresses clone detected messages for approximately 3 minutes under certain conditions.

The log message provides the cable interface and MAC address of the cable modem attempting to register when another physical modem with that same MAC address is already in a state of online(p\_) elsewhere on the Cisco CMTS router.

## DOCSIS 3.0 BPI+ Policy Enforcement

The DOCSIS 3.0 BPI+ Policy Enforcement feature was introduced to prevent cable modem MAC address cloning and theft of service. This feature enables a Cisco CMTS router to validate the MAC address of each cable modem. To enforce BPI+ on cable modems, you must configure one of the following enforcement policies per MAC domain on the router:

- 1.1 Style Configuration File Parameters and Capability (Policy 1)—The Cisco CMTS router enforces BPI+ on cable modems that register with a DOCSIS 1.1 configuration file with parameters indicating BPI+ is enabled with or without TLV 29. To configure this policy, the privacy support modem capability TLV (type 5.6) in the DOCSIS configuration file must be set to BPI+ support. This policy forces BPI+ on a cable modem that is BPI+ capable and provisioned with DOCSIS 1.1 configuration file. A cable modem that signals these capabilities during registration is blocked from accessing the network until the modem completes BPI+ negotiation.
- 1.1 Style Configuration File Parameters (Policy 2)—The Cisco CMTS router enforces BPI+ on cable modems that register with a DOCSIS 1.1 configuration file with parameters indicating BPI+ is enabled with or without TLV 29. A cable modem that registers with this type of configuration file is blocked from accessing the network until the modem completes BPI+ negotiation.
- 1.1 Style Configuration File (Policy 3)—The Cisco CMTS router enforces BPI+ on cable modems that register with a DOCSIS 1.1 configuration file. This means that if you provision a DOCSIS 1.1 configuration file with security disabled (privacy flag is not present in the configuration file), all DOCSIS 1.1 and 2.0 cable modems are blocked from accessing the network. Only the DOCSIS 3.0 cable modems that have security enabled implicitly will pass this check if the privacy flag is not present in the configuration file.
- Total enforcement (Policy 4)—The Cisco CMTS router enforces BPI+ on all cable modems. This means that all cable modems that do not run BPI+ are blocked from accessing the network.



**Note** You can configure only one enforcement policy at a time per MAC domain. If you configure one policy after another, the latest policy supersedes the already existing policy. For example, if you want Policy 2 to take over Policy 1, you can directly configure the former without disabling the latter.

These enforcement policies are implemented based on CableLabs Security Specification, CM-SP-SECv3.0-I13-100611. You can configure these enforcement policies using the **cable privacy bpi-plus-policy** command in cable interface configuration mode. The cable modems that do not comply with the configured policy can still come online but they cannot access the DOCSIS network and some dual stack cable modems may not get both the IPv4 and IPv6 addresses.

Policies 1, 2, and 3 support a mixed network of DOCSIS 1.0 (including DOCSIS Set-top Gateway), DOCSIS 1.1, and later cable modems. Policy 4 is the most effective configuration for preventing cable modem MAC address cloning as this policy enforces BPI+ on all cable modems. Policy 4 blocks all DOCSIS 1.0 cable modems as they do not register in BPI+ mode. Therefore, if Policy 4 is used, you must upgrade all authorized DOCSIS 1.0 cable modems or remove them from the network.

## BPI+ Policy Enforcement Exclusion

You can exclude cable modems (DOCSIS 1.0 and later versions) from BPI+ policy enforcement based on their MAC addresses, using the **cable privacy bpi-plus-exclude** command in global configuration mode. You can exclude a maximum of 30 cable modems per MAC domain.

# How to Configure EAE and BPI+ Enforcement Features

This section provides information on how to configure the following BPI+ enforcement features:

## Configuring EAE Enforcement Policies

By default, EAE is disabled on the Cisco CMTS router. You can configure EAE enforcement policies using the **cable privacy eae-policy** command in cable interface configuration mode.



**Note** EAE enforcement policies are enabled only for the DOCSIS 3.0 cable modems that initialize on a downstream channel.

### Procedure

|        | Command or Action                                         | Purpose                                                                                                            |
|--------|-----------------------------------------------------------|--------------------------------------------------------------------------------------------------------------------|
| Step 1 | <b>enable</b><br><b>Example:</b><br>Router> <b>enable</b> | Enables privileged EXEC mode. <ul style="list-style-type: none"> <li>• Enter your password if prompted.</li> </ul> |
| Step 2 | <b>configure terminal</b><br><b>Example:</b>              | Enters global configuration mode.                                                                                  |



|               | Command or Action                                                                                                                                                                                                                                       | Purpose                                                        |
|---------------|---------------------------------------------------------------------------------------------------------------------------------------------------------------------------------------------------------------------------------------------------------|----------------------------------------------------------------|
|               | Router# <code>configure terminal</code>                                                                                                                                                                                                                 |                                                                |
| <b>Step 3</b> | <b>interface cable</b> { <i>slot/cable-interface-index</i>   <i>slot/subslot/cable-interface-index</i> }<br><b>Example:</b><br>Router(config)# <code>interface cable 6/0/1</code>                                                                       | Enters interface configuration mode.                           |
| <b>Step 4</b> | <b>cable privacy eae-policy</b> { <b>capability-enforcement</b>   <b>disable-enforcement</b>   <b>ranging-enforcement</b>   <b>total-enforcement</b> }<br><b>Example:</b><br>Router(config-if)# <code>cable privacy eae-policy total-enforcement</code> | Specifies EAE enforcement policies on DOCSIS 3.0 cable modems. |
| <b>Step 5</b> | <b>end</b><br><b>Example:</b><br>Router(config)# <code>end</code>                                                                                                                                                                                       | Returns to privileged EXEC mode.                               |

## Configuring BPI+ Enforcement Policies

The BPI+ enforcement policies are configured per MAC domain to prevent cable modem MAC address cloning and theft of service.

### Before you begin

The customer premise equipment (CPE) must use DHCP to acquire IP addresses to access the network, or the statically assigned IP addresses must be managed appropriately.



**Note** Only a single enforcement policy can be applied per MAC domain.

### Procedure

|               | Command or Action                                               | Purpose                                                                                                            |
|---------------|-----------------------------------------------------------------|--------------------------------------------------------------------------------------------------------------------|
| <b>Step 1</b> | <b>enable</b><br><b>Example:</b><br>Router> <code>enable</code> | Enables privileged EXEC mode. <ul style="list-style-type: none"> <li>• Enter your password if prompted.</li> </ul> |

|               | Command or Action                                                                                                                                                                                                               | Purpose                                                         |
|---------------|---------------------------------------------------------------------------------------------------------------------------------------------------------------------------------------------------------------------------------|-----------------------------------------------------------------|
| <b>Step 2</b> | <b>configure terminal</b><br><b>Example:</b><br><pre>Router# configure terminal</pre>                                                                                                                                           | Enters global configuration mode.                               |
| <b>Step 3</b> | <b>interface cable {slot/subslot/port /slot/port}</b><br><b>Example:</b><br><pre>Router(config)# interface cable 5/1/0</pre>                                                                                                    | Specifies the cable interface line card on a Cisco CMTS router. |
| <b>Step 4</b> | <b>cable privacy bpi-plus-policy {capable-enforcement   d11-enabled-enforcement   d11-enforcement   total-enforcement}</b><br><b>Example:</b><br><pre>Router (config-if)# cable privacy bpi-plus-policy total-enforcement</pre> | Specifies the BPI+ enforcement policies per MAC domain.         |
| <b>Step 5</b> | <b>end</b><br><b>Example:</b><br><pre>Router(config-if)# end</pre>                                                                                                                                                              | Returns to Privileged EXEC mode.                                |

## Configuring AES-128 for non-MTC DOCSIS3.0 Cable Modem

This feature is enabled by default. To disable this feature, follow the steps below:

```
enable
configure terminal
no cable privacy non-mtc-aes128
end
```

## Verifying AES-128 for non-MTC DOCSIS3.0 Cable Modem

To verify whether AES-128 is supported for non-MTC DOCSIS3.0 Cable Modem, use **show running-config** command as shown in the example below:

```
Router# show running-config | include cable privacy non-mtc-aes128
no cable privacy non-mtc-aes128
```

## Troubleshooting Tips

Use the following debug commands to troubleshoot BPI+ policy enforcement configuration:

- **debug cable mac-address**—Provides debugging information about a specific cable modem.
- **debug cable bpiatp**—Enables debugging of the BPI handler.

## Configuration Example for EAE and BPI+ Enforcement Policies

The following example shows how to configure an EAE enforcement policy on the Cisco cBR-8 router:

```
Router# configure terminal
Router(config)# interface cable 8/1/0
Router (config-if)# cable privacy eae-policy capability-enforcement
Router (config-if)# cable privacy eae-policy ranging-enforcement
Router (config-if)# cable privacy eae-policy total-enforcement
```

The following example shows how to configure a BPI+ enforcement policy at slot/subslot/port 5/1/0 on the Cisco cBR-8 router:

```
Router# configure terminal
Router(config)# interface cable 5/1/0
Router (config-if)# cable privacy bpi-plus-policy total-enforcement
```

## Verifying EAE and BPI+ Enforcement Policies

Use the following show commands to verify EAE and BPI+ enforcement configurations:

- **show interface cable privacy**
- **show cable privacy**
- **show cable modem access-group**

To verify which EAE policy is configured on the Cisco CMTS router, use the **show interface cable privacy** command.

To verify which cable modems are excluded from EAE enforcement on the Cisco CMTS router, use the **show cable privacy** command.

To verify BPI+ enforcement policies, use the **show interface cable privacy** command.



---

**Note** A character "\*" is placed before the online state to identify modems that have not satisfied the bpi-plus-policy.

---

## What to Do Next

The Cloned Cable Modem Detection feature relates to multiple BPI+ certificate and DOCSIS 1.1 factors.

# System Messages Supporting Cable Duplicate MAC Address Reject

The following example illustrates logged events for the Cloned Cable Modem Detection feature on a Cisco cBR-8 router.

In the below scenario, there are two cable modems with MAC addresses that have been cloned:

- For MAC address 000f.66f9.48b1, the legitimate cable modem is on C5/0/0 upstream 0, and the cloned cable modem is on C7/0/0.
- For MAC address 0013.7116.e726, the legitimate cable modem is on C7/0/0 upstream 0, and the cloned cable modem is also on the same interface.
- In the below example, the CMMOVED message occurred because the cloned cable modem for MAC address 000f.66f9.48b1 came online before the legitimate cable modem.
- There is no CMMOVED message for the cable modem on interface C7/0/0 with MAC address 0013.7116.e726 because the legitimate cable modem came online with state of online(pt) before the cloned cable modem attempted to come online.

```
Dec 5 13:08:18: %CBR-6-CMMOVED: Cable modem 000f.66f9.48b1 has been moved from interface
Cable7/0/0 to interface C able5/0/0.
Dec 5 13:08:44: %CBR-5-CLONED_CM_DETECTED: Cloned CM with MAC address 0013.7116.e726
connection attempt rejected o n Cable7/0/0 U0
Dec 5 13:10:48: %CBR-5-CLONED_CM_DETECTED: Cloned CM with MAC address 000f.66f9.48b1
connection attempt rejected on Cable7/0/0 U1
Dec 5 13:12:37: %CBR-5-CLONED_CM_DETECTED: Cloned CM with MAC address 0013.7116.e726
connection attempt rejected on Cable7/0/0 U0
Dec 5 13:18:28: %CBR-5-CLONED_CM_DETECTED: Cloned CM with MAC address 0013.7116.e726
connection attempt rejected on Cable7/0/0 U0
Dec 5 13:18:28: %CBR-5-CLONED_CM_DETECTED: Cloned CM with MAC address 0013.7116.e726
connection attempt rejected o n Cable7/0/0 U0
```

The following example of the **show cable modem** command illustrates additional cable modem information for the above scenario involving the specified MAC addresses:

```
Router# show cable modem 000f.66f9.48b1
MAC Address      IP Address      I/F           MAC           Prim RxPwr  Timing Num BPI
                  State           State         Sid  (dBmv) Offset CPE Enb
000f.66f9.48b1  4.222.0.253    C5/0/0/U0    online(pt)    24    0.50  1045    1    Y
```

## Additional References

### Technical Assistance

| Description                                                                                                                                                                                                                                                                                                                                                                           | Link                                                                                                              |
|---------------------------------------------------------------------------------------------------------------------------------------------------------------------------------------------------------------------------------------------------------------------------------------------------------------------------------------------------------------------------------------|-------------------------------------------------------------------------------------------------------------------|
| The Cisco Support and Documentation website provides online resources to download documentation, software, and tools. Use these resources to install and configure the software and to troubleshoot and resolve technical issues with Cisco products and technologies. Access to most tools on the Cisco Support and Documentation website requires a Cisco.com user ID and password. | <a href="http://www.cisco.com/cisco/web/support/index.html">http://www.cisco.com/cisco/web/support/index.html</a> |

## Feature Information for Cable Duplicate MAC Address Reject

Use Cisco Feature Navigator to find information about the platform support and software image support. Cisco Feature Navigator enables you to determine which software images support a specific software release, feature set, or platform. To access Cisco Feature Navigator, go to the <https://cfmng.cisco.com/> link. An account on the Cisco.com page is not required.



**Note** The following table lists the software release in which a given feature is introduced. Unless noted otherwise, subsequent releases of that software release train also support that feature.

**Table 322: Feature Information for Cable Duplicate MAC Address Reject**

| Feature Name                               | Releases                    | Feature Information                                                                                               |
|--------------------------------------------|-----------------------------|-------------------------------------------------------------------------------------------------------------------|
| Cable Duplicate MAC Address Reject         | Cisco IOS XE Everest 16.6.1 | This feature was integrated into Cisco IOS XE Everest 16.6.1 on the Cisco cBR Series Converged Broadband Routers. |
| AES-128 for non-MTC DOCSIS 3.0 Cable Modem | Cisco IOS XE Everest 16.6.1 | This feature was integrated into Cisco IOS XE Everest 16.6.1 on the Cisco cBR Series Converged Broadband Routers. |





## CHAPTER 103

# Cable ARP Filtering

---

This document describes the Cable ARP Filtering feature for the Cisco Cable Modem Termination System (CMTS). This feature enables service providers to filter Address Resolution Protocol (ARP) requests and reply packets, to prevent a large volume of such packets from interfering with the other traffic on the cable network.

Your software release may not support all the features that are documented in this module. For the latest feature information and caveats, see the release notes for your platform and software release. The Feature Information Table at the end of this document provides information about the documented features and lists the releases in which each feature is supported.

Use Cisco Feature Navigator to find information about platform support and Cisco software image support. To access Cisco Feature Navigator, go to <http://tools.cisco.com/ITDIT/CFN/>. An account on <http://www.cisco.com/> is not required.

### Contents

- [Hardware Compatibility Matrix for the Cisco cBR Series Routers, on page 1635](#)
- [Restrictions for Cable ARP Filtering, on page 1637](#)
- [Cable ARP Filtering, on page 1637](#)
- [How to Configure Cable ARP Filtering, on page 1641](#)
- [Configuration Examples for Cable ARP Filtering, on page 1650](#)
- [Additional References, on page 1652](#)
- [Feature Information for Cable ARP Filtering, on page 1653](#)

## Hardware Compatibility Matrix for the Cisco cBR Series Routers



---

**Note** The hardware components that are introduced in a given Cisco IOS-XE Release are supported in all subsequent releases unless otherwise specified.

---

Table 323: Hardware Compatibility Matrix for the Cisco cBR Series Routers

| Cisco CMTS Platform                    | Processor Engine                                                                                                                                                                                  | Interface Cards                                                                                                                                                                                                                                                                                                                                                                                                                                                                                                                                                                                                                                                                                                                                                                                 |
|----------------------------------------|---------------------------------------------------------------------------------------------------------------------------------------------------------------------------------------------------|-------------------------------------------------------------------------------------------------------------------------------------------------------------------------------------------------------------------------------------------------------------------------------------------------------------------------------------------------------------------------------------------------------------------------------------------------------------------------------------------------------------------------------------------------------------------------------------------------------------------------------------------------------------------------------------------------------------------------------------------------------------------------------------------------|
| Cisco cBR-8 Converged Broadband Router | <p><b>Cisco IOS-XE Release 16.5.1 and Later Releases</b></p> <p>Cisco cBR-8 Supervisor:</p> <ul style="list-style-type: none"> <li>• PID—CBR-SUP-250G</li> <li>• PID—CBR-CCAP-SUP-160G</li> </ul> | <p><b>Cisco IOS-XE Release 16.5.1 and Later Releases</b></p> <p>Cisco cBR-8 CCAP Line Cards:</p> <ul style="list-style-type: none"> <li>• PID—CBR-LC-8D30-16U30</li> <li>• PID—CBR-LC-8D31-16U30</li> <li>• PID—CBR-RF-PIC</li> <li>• PID—CBR-RF-PROT-PIC</li> <li>• PID—CBR-CCAP-LC-40G</li> <li>• PID—CBR-CCAP-LC-40G-R</li> <li>• PID—CBR-CCAP-LC-G2-R</li> <li>• PID—CBR-SUP-8X10G-PIC</li> <li>• PID—CBR-2X100G-PIC</li> </ul> <p>Digital PICs:</p> <ul style="list-style-type: none"> <li>• PID—CBR-DPIC-8X10G</li> <li>• PID—CBR-DPIC-2X100G</li> </ul> <p>Cisco cBR-8 Downstream PHY Module:</p> <ul style="list-style-type: none"> <li>• PID—CBR-D31-DS-MOD</li> </ul> <p>Cisco cBR-8 Upstream PHY Modules:</p> <ul style="list-style-type: none"> <li>• PID—CBR-D31-US-MOD</li> </ul> |



**Note** Do not use DPICs (8X10G and 2x100G) to forward IP traffic, as it may cause buffer exhaustion, leading to line card reload.

The only allowed traffic on a DPIC interface is DEPI, UEPI, and GCP traffic from the Cisco cBR-8 router to Remote PHY devices. Other traffic such as DHCP, SSH, and UTSC should flow via another router, since DPICs cannot be used for normal routing.



# Restrictions for Cable ARP Filtering

## Cisco cBR-8 Router Restrictions

- The Cisco cBR-8 router maintains ARP filtering statistics on the Supervisor (SUP) module. Statistics are viewed with the **show cable arp-filter** command for a specific interface. When a switchover event occurs, as in SUP redundancy, these ARP filtering statistics are reset to zero.
- The Cable ARP filter feature is not configurable for each subinterface.

## FP ARP Filter Restrictions

- The FP microcode must be enhanced to provide the rate limiting functionality for ARP filtering in FP.
- The ARP filter in FP feature is not configurable for each subinterface.

# Cable ARP Filtering

Theft-of-service and denial-of-service (DNS) attacks have become increasingly common in cable broadband networks. In addition, virus attacks are becoming more common, and users are often unaware that their computers have become infected and are being used to continue the attacks on the network.

One sign that often appears during these attacks is an unusually high volume of Address Resolution Protocol (ARP) packets. The user or virus repeatedly issues ARP requests, trying to find the IP addresses of additional computers that might be vulnerable to attack.

ARP requests are broadcast packets, so they are broadcast to all devices on that particular network segment. In some cases, a router can also forward ARP broadcasts to an ARP proxy for further processing.

This problem is also made worse because some low-end routers commonly used by subscribers for home networks can also incorrectly respond to all ARP requests, which generates even more traffic. Until these customer premises equipment (CPE) devices can be upgraded with firmware that is compliant to the appropriate Request for Comments (RFC) specifications, service providers need to be able to deal with the incorrectly generated or forwarded traffic.

In addition, the Cisco CMTS router automatically monitors ARP traffic and enters the IP addresses found in ARP requests into its own ARP table, in the expectation that a device will eventually be found with that IP address. Unacknowledged IP addresses remain in the router's ARP table for 60 seconds, which means that a large volume of ARP traffic can fill the router's ARP table.

This process can create a large volume of ARP traffic across the network. In some situations, the volume of ARP requests and replies can become so great that it can throttle other traffic and occupy most of the Cisco CMTS router's processing time, hampering efforts by technicians to recover their network.

The router cannot use fast-switching to process ARP packets, but must instead forward them to the route processor (RP). Because of this, processing a large volume of ARP traffic can also prevent the router from handling normal traffic.

## Overview

Theft-of-service and denial-of-service (DNS) attacks have become increasingly common in cable broadband networks. In addition, virus attacks are becoming more common, and users are often unaware that their computers have become infected and are being used to continue the attacks on the network.

One sign that often appears during these attacks is an unusually high volume of Address Resolution Protocol (ARP) packets. The user or virus repeatedly issues ARP requests, trying to find the IP addresses of additional computers that might be vulnerable to attack.

ARP requests are broadcast packets, so they are broadcast to all devices on that particular network segment. In some cases, a router can also forward ARP broadcasts to an ARP proxy for further processing.

This problem is also made worse because some low-end routers commonly used by subscribers for home networks can also incorrectly respond to all ARP requests, which generates even more traffic. Until these customer premises equipment (CPE) devices can be upgraded with firmware that is compliant to the appropriate Request for Comments (RFC) specifications, service providers need to be able to deal with the incorrectly generated or forwarded traffic.

In addition, the Cisco CMTS router automatically monitors ARP traffic and enters the IP addresses found in ARP requests into its own ARP table, in the expectation that a device will eventually be found with that IP address. Unacknowledged IP addresses remain in the router's ARP table for 60 seconds, which means that a large volume of ARP traffic can fill the router's ARP table.

This process can create a large volume of ARP traffic across the network. In some situations, the volume of ARP requests and replies can become so great that it can throttle other traffic and occupy most of the Cisco CMTS router's processing time, hampering efforts by technicians to recover their network.

The router cannot use fast-switching to process ARP packets, but must instead forward them to the route processor (RP). Because of this, processing a large volume of ARP traffic can also prevent the router from handling normal traffic.

## Filtering ARP Traffic

To control the volume of ARP traffic on a cable interface, you can configure the **cable arp filter** command to specify how many ARP packets are allowed per Service ID (SID) during a user-specified time period. You can configure separate thresholds for ARP request packets and for ARP reply packets.

When a cable interface is configured to filter ARP packets, it maintains a table of the number of ARP request or reply packets that have been received for each SID. If a SID exceeds the maximum number of packets during the window time period, the Cisco CMTS drops the packets until a new time period begins.



---

**Note** If using bundled cable interfaces, the Cable ARP Filtering feature is configured on the primary and subordinate interfaces separately. This allows you to configure the feature only on the particular interfaces that require it. In addition, you can configure the feature with different threshold values, allowing you to customize the feature for each interface's traffic patterns.

---

## Monitoring Filtered ARP Traffic

After ARP filtering has been enabled on a cable interface, you can then use the service **divert-rate-limit** command to display the devices that are generating excessive amounts of ARP traffic. These devices could be generating this traffic for any of the following reasons:

- Cable modems that are running software images that are either not DOCSIS-compliant or that have been hacked to allow theft-of-service attacks.
- CPE devices that are either performing a theft-of-service or denial-of-service attack, or that have been infected with a virus that is searching for other computers that can be infected.
- Routers or other devices that mistakenly reply to or forward all ARP requests.

After identifying the specific devices that are generating this traffic, you can use whatever techniques are allowed by your service level agreements (SLAs) to correct the problem.

## ARP Autoreply

Built-in routers (eRouters) in cable modems, typically use the Linux operating system, which has a default Address Resolution Protocol (ARP) refresh time of 30 or 60 seconds. With randomizing skew, the cable bundle interface receives a unicast ARP from an eRouter approximately every 45 seconds.

Large-scale deployments may have over 20000 eRouters, which results in a steady-state ARP rate of over 400 packets per second. All ARPs are processed by the route processor (RP), consuming a significant amount of CPU.

To reduce CPU consumption, unicast ARPs can be processed in the dataplane in certain conditions. However, a dataplane-processed ARP does not refresh the ARP-refresh time-out that is maintained by the RP. Hence, the dataplane must periodically punt a unicast ARP.

To achieve both, the ARP-filter feature is enabled on the subscriber-side source-based rate limit (SBRL), and the SBRL processing for ARP is also updated for ARP autoreply functionality.

ARP autoreply is enabled by default, and the ARP-filter default setting is changed to disabled. You can revert the configuration when required, where the ARP-filter is enabled, and both subscriber-side SBRL for ARP and ARP autoreply are disabled.

With the ARP autoreply feature in Cisco cBR-8 router, the default configuration for ARP filter is:

```
(config-if)# no cable arp filter request-send  
(config-if)# no cable arp filter reply-accept
```

## Linksys Wireless-Broadband Router (BEFW11S4)

The Linksys Wireless-B Broadband Router, Model number BEFW11S4 version 4 with 1.44.2 firmware, incorrectly sends its own ARP reply packet for every ARP request packet it receives, instead of replying only to the ARP requests that are specifically for itself. Customers with these routers should upgrade the firmware to the latest revision to fix this bug. To upgrade the firmware, go to the download section on the Linksys website.



---

**Note** It is extremely important that non-compliant CPE devices be updated to firmware that correctly handles ARP and other broadcast traffic. Even one or two non-compliant devices on a segment can create a significant problem with dropped packets, impacting all of the other customers on that segment.

---

## ARP Filtering in FP

ARP filter feature is performed on SUP FP complex. When enabled, this FP complex filters ARP packets for identified ARP offenders, decreasing the ARP punt rate and RP CPU usage. It also provides the user with clearer separation in ARP filtering by utilizing source MAC addresses instead of SIDs.

The filter logic now filters by source MAC address instead of by SID. Currently, the modem MAC addresses are excluded from having their ARPs filtered, but Multimedia Terminal Adapters (MTAs) and other non-offending CPEs can still (statistically) have ARPs filtered because all ARPs appear to come from the same SID. Therefore, filtering by source MAC address will isolate the filtering to the offensive devices. By doing so, a customer who has Voice-over-IP (VoIP) service via an MTA and an infected CPE will not have MTA issues while being contacted by the service provider in regards to the infected CPE.

ARP offenders will still be allowed to use ARP to avoid complete loss of Internet connectivity through their configured or provisioned gateway address. Because of this, it is expected that the “ARP Input” process will still show a few percentage points of CPU usage, but the net interrupt CPU usage will decrease.



---

**Note** ARP filtering in FP is enabled by default on Cisco cBR-8 router.

---

## Filtering ARP Traffic in FP

When ARP traffic in FP is enabled, a lightweight algorithm executing on the RP is used to identify ARP offenders by the source MAC address or the SID. All offending source MAC addresses or SIDs are then programmed by the ARP Filter control module into the FP ucode divert rate limiting module (ARP offenders are still allowed to perform ARP transactions, but only at the configured filtering rate).

Offending source MAC addresses or SIDs are filtered in FP for a minimum of 50 minutes (ten 5-minute intervals with no occurring offenses). Utilizing the existing ARP Filter CLI tools, the cable operator can obtain enough information about the modem and CPE to contact the end user to request the necessary anti-virus software installation or firmware upgrade for the CPE.



---

**Note** If the offending device is not “repaired” or shut off, it will remain in the FP ARP Filter indefinitely.

---

The FP ARP rate limiter is designed to filter a maximum of 16,000 ARP offenders. If this pool of 16,000 filterable entities is exhausted, then the entity is filtered on the RP. The CLI statistics will distinguish mac addresses filtered on the RP versus FP.

Because of possible mac address hash collisions, ARP offenders that cannot be programmed into the FP ARP rate limiter will still be filtered in FP by SID. Since the hash is done by source mac address and SID, such devices can actually moved back to mac address filtering by deleting the associated modem and forcing it back online with a new SID (this merely a possibility and is not expected to be a common practice).

ARP packets with a source mac address that is not “known” to the CMTS as a modem or CPE will be filtered by their SID in FP. Therefore, there will never be an unusual ARP packet source that will NOT be filtered in FP. False ARP packets with invalid operation codes will be filtered as if they are an ARP Reply.

# How to Configure Cable ARP Filtering

Use the following procedures to determine whether ARP filtering is required and to configure ARP filtering on one or more cable interfaces.

## Monitoring ARP Processing

Use the following steps to monitor how the router is processing ARP traffic and whether the volume of ARP packets is a potential problem.

**Step 1** To discover the CPU processes that are running most often, use the **show process cpu sorted** command and look for the ARP Input process:

**Example:**

```
Router# show process cpu sorted

CPU utilization for five seconds: 99%/28%; one minute: 93%; five minutes: 90%
PID Runtime(ms)   Invoked    uSecs   5Sec   1Min   5Min  TTY Process
  19   139857888     44879804    3116 31.44% 28.84% 28.47% 0 ARP Input
 154   74300964     49856254    1490 20.29% 19.46% 15.78% 0 SNMP ENGINE
  91   70251936     1070352    65635  8.92%  9.62%  9.59% 0 CEF process
  56   17413012     97415887     178  3.01%  3.67%  3.28% 0 C10K BPE IP Enqu
  78   24985008     44343708     563  3.68%  3.47%  3.24% 0 IP Input
  54    6075792      6577800     923  0.90%  0.67%  0.65% 0 CMTS SID mgmt ta
...
```

In this example, the ARP Input process has used 31.44 percent of the CPU for the past five seconds. Total CPU utilization is also at 99 percent, indicating that a major problem exists on the router.

**Note** As a general rule, the ARP Input process should use no more than one percent of CPU processing time during normal operations. The ARP Input process could use more processing time during certain situations, such as when thousands of cable modems are registering at the same time, but if it uses more than one percent of processing time during normal operations, it probably indicates a problem.

**Step 2** To monitor only the ARP processes, use the **show process cpu | include ARP** command:

**Example:**

```
Router# show process cpu | include ARP

  19   139857888     44879804    3116 31.44% 28.84% 28.47% 0 ARP Input
 110         0         1         0  0.00%  0.00%  0.00% 0 RARP Input
```

**Step 3** To monitor the number of ARP packets being processed, use the **show ip traffic** command.

**Example:**

```
Router# show ip traffic | begin ARP

ARP statistics:
  Rcvd: 11241074 requests, 390880354 replies, 0 reverse, 0 other
```

```
Sent: 22075062 requests, 10047583 replies (2127731 proxy), 0 reverse
```

Repeat this command to see how rapidly the ARP traffic increases.

**Step 4** If ARP traffic appears to be excessive, use the **show cable arp-filter** command to display ARP traffic for each cable interface, to identify the interfaces that are generating the majority of the traffic.

**Example:**

```
Router# show cable arp-filter Cable5/0/0

ARP Filter statistics for Cable5/0/0:
  Rcvd Replies: 177387 total, 0 unfiltered, 0 filtered
  Sent Requests For IP: 68625 total, 0 unfiltered, 0 filtered
  Sent Requests Proxied: 7969175 total, 0 unfiltered, 0 filtered
```

In the above example, the unfiltered and filtered counters show zero, which indicates that ARP filtering has not been enabled on the cable interface. After ARP filtering has been enabled with the **cable arp filter** command, you can identify the specific devices that are generating excessive ARP traffic by using the **service divert-rate-limit** command (see the [Identifying the Sources of Major ARP Traffic, on page 1645](#)).

## Configure ARP Autoreply

To configure ARP autoreply time and the subscriber-side SBRL, run the following command:

```
Router# configure terminal
Router(config)# platform punt-sbri subscriber punt-cause arp rate-per-4-sec {R}
[bucket-size {B}] [autoreply-time {T}]
```

To disable ARP autoreply and subscriber-side SBRL for ARP, run the following command:

```
Router(config)# platform punt-sbri subscriber punt-cause arp rate-per-4-sec no-drop
```

| Keyword            | Range     | Default | Units             |
|--------------------|-----------|---------|-------------------|
| rate-per-4-sec {R} | [1 - 255] | 6       | packets-per-4-sec |
| bucket-size {B}    | 1 - 255]  | 6       | packets           |
| autoreply-time {T} | [1 - 60]  | 5       | minutes           |

### View SBRL Statistics

Run the following sample commands to see the SBRL statistics:

```
Router#show platform hardware qfp active infrastructure punt sbri
SBRL statistics
```

```
Subscriber MAC-addr
  drop-cnt   evict-cnt  quar  MAC-Address      ID  punt-cause
```

```
-----
                2           2           0  xxxx.xxxx.xxxx  103  cable-pre-reg
```

```

      4          4          0  xxxx.xxxx.xxxx 103  cable-pre-reg
      4          4          0  xxxx.xxxx.xxxx 103  cable-pre-reg
     10         10          0  xxxx.xxxx.xxxx 103  cable-pre-reg
      2          2          0  xxxx.xxxx.xxxx 103  cable-pre-reg
     15         15          0  xxxx.xxxx.xxxx 103  cable-pre-reg
    285        285          0  xxxx.xxxx.xxxx 103  cable-pre-reg
 2919265    2919265      0  xxxx.xxxx.xxxx 055  for-us-ctrl
 499440     499440      0  xxxx.xxxx.xxxx 134  cbl-dhcpv4-sub

```

```

WAN-IPv4
  nothing to report

```

```

WAN-IPv6
  nothing to report

```

```
Router#
```

```

show platform hardware qfp active infrastructure punt sbrl
clear          Clear the sbrl statistics
  sub-mac-addr Show the SBRL subscriber MAC-addr statistics
  threshold    Show the sbrl stats gte threshold
  wan-ipv4     Show the SBRL WAN IPv4 statistics
  wan-ipv6     Show the SBRL WAN IPv6 statistics
  |           Output modifiers
  <cr>       <cr>

```

```

Router#show platform hardware qfp active infrastructure punt sbrl sub-mac-addr mac-address
xxxx.xxxx.xxxx
Load for five secs: 19%/0%; one minute: 12%; five minutes: 12%
Time source is NTP, *09:47:31.486 EDT Mon Sep 13 2021
SBRL statistics

```

```

Subscriber MAC-addr
  drop-cnt  evict-cnt  quar  MAC-Address      ID  punt-cause
-----
  2919324   2919324   0   xxxx.xxxx.xxxx 055  for-us-ctrl
  499440    499440    0   xxxx.xxxx.xxxx 134  cbl-dhcpv4-sub

```

```

show platform hardware qfp active infrastructure punt sbrl sub-mac-addr punt-cause
<0-65535> punt-cause

```

```

Router#show platform hardware qfp active infrastructure punt sbrl sub-mac-addr punt-cause
103
Load for five secs: 14%/0%; one minute: 12%; five minutes: 12%
Time source is NTP, *09:48:01.221 EDT Mon Sep 13 2021
SBRL statistics

```

```

Subscriber MAC-addr
  drop-cnt  evict-cnt  quar  MAC-Address      ID  punt-cause
-----

```

```

2          2          0  xxxx.xxxx.xxxx  103  cable-pre-reg
4          4          0  xxxx.xxxx.xxxx  103  cable-pre-reg
4          4          0  xxxx.xxxx.xxxx  103  cable-pre-reg
10         10         0  xxxx.xxxx.xxxx  103  cable-pre-reg
2          2          0  xxxx.xxxx.xxxx  103  cable-pre-reg
15         15         0  xxxx.xxxx.xxxx  103  cable-pre-reg
285       285        0  xxxx.xxxx.xxxx  103  cable-pre-reg

```

```
Router# 103
```

## Configure ARP Filter Without ARP Autoreply

To revert to the ARP filter configuration and disable ARP autoreply, use the following procedure:

1. Disable ARP rate-limiting in subscriber-side SBRL:

```
(config)# platform punt-sbri subscriber punt-cause arp rate-per-4-sec no-drop
```

2. Enable ARP filter on the bundle interface:

```
(config-if)# cable arp filter request-send {num-pkts} {seconds}
(config-if)# cable arp filter reply-accept {num-pkts} {seconds}
```

## Enabling ARP Filtering

Use the following procedure to enable ARP filtering on a particular cable interface.

### Procedure

|               | Command or Action                                                                           | Purpose                                                                |
|---------------|---------------------------------------------------------------------------------------------|------------------------------------------------------------------------|
| <b>Step 1</b> | <b>enable</b><br><b>Example:</b><br>Router> <b>enable</b>                                   | Enables privileged EXEC mode. Enter your password if prompted.         |
| <b>Step 2</b> | <b>configure terminal</b><br><b>Example:</b><br>Router# <b>configure terminal</b>           | Enters global configuration mode.                                      |
| <b>Step 3</b> | <b>interface cable x/y</b><br><b>Example:</b><br>Router(config)# <b>interface cable 5/1</b> | Enters interface configuration mode for the specified cable interface. |



|        | Command or Action                                                                                                                                    | Purpose                                                                                                                                                                                                                                                                                                                                                                                                                                                                                                  |
|--------|------------------------------------------------------------------------------------------------------------------------------------------------------|----------------------------------------------------------------------------------------------------------------------------------------------------------------------------------------------------------------------------------------------------------------------------------------------------------------------------------------------------------------------------------------------------------------------------------------------------------------------------------------------------------|
| Step 4 | <b>cable arp filter reply-accept</b> <i>number window-size</i><br><b>Example:</b><br><pre>Router(config-if)# cable arp filter reply-accept 2 2</pre> | Configures the cable interface to accept only the specified <i>number</i> of ARP reply packets every <i>window-size</i> seconds for each active Service ID (SID) on that interface. The cable interface drops ARP reply packets for a SID that would exceed this number. (The default behavior is to accept all ARP reply packets.)                                                                                                                                                                      |
| Step 5 | <b>cable arp filter request-send</b> <i>number window-size</i><br><b>Example:</b><br><pre>Router(config-if)# cable arp filter request-send 3 1</pre> | Configures the cable interface to send only the specified <i>number</i> of ARP request packets every <i>window-size</i> seconds for each active SID on that interface. The cable interface drops ARP requests for a SID that would exceed this number. (The default behavior is to send all ARP request packets.)<br><br><b>Note</b> Repeat Step 3 through Step 5 to enable ARP filtering on other cable interfaces. Primary and subordinate interfaces in a cable bundle must be configured separately. |
| Step 6 | <b>end</b><br><b>Example:</b><br><pre>Router(config-if)# end</pre>                                                                                   | Exits interface configuration mode and returns to privileged EXEC mode.                                                                                                                                                                                                                                                                                                                                                                                                                                  |

## Identifying the Sources of Major ARP Traffic

After you have begun filtering ARP traffic on a cable interface, use the following procedure to identify the cable modems or CPE devices that are generating or forwarding major amounts of ARP traffic.



**Tip** The Linksys Wireless-B Broadband Router, Model number BEFW11S4 version 4 with 1.44.2 firmware, has a known problem in which it incorrectly generates an ARP reply for every ARP request packet it receives. See the [Linksys Wireless-Broadband Router \(BEFW11S4\)](#) guide for information on how to resolve this problem.

**Step 1** To discover the devices that are responsible for generating or forwarding more ARP requests on a specific cable interface than a specified minimum number of packets, use the **show cable arp-filter requests-filtered** command where *number* is the threshold value for the number of packets being generated:

**Example:**

```
show cable arp-filter cable interface requests-filtered number
```

For example, to display the devices that have generated more than 100 ARP request packets, enter the following command:

**Example:**

```
Router# show cable arp-filter cable 5/1/0 requests-filtered 100
```

| Sid | MAC Address    | IP Address | Req-Filtered | Req-For-IP-Filtered | Rep-Filtered |
|-----|----------------|------------|--------------|---------------------|--------------|
| 1   | 0006.2854.72d7 | 10.3.81.4  | 12407        | 0                   | 0            |
| 81  | 00C0.c726.6b14 | 10.3.81.31 | 743          | 0                   | 0            |

**Step 2** Repeat the **show cable arp-filter** command to show how quickly the devices are generating the ARP packets.

**Step 3** To discover the devices that are responsible for generating or forwarding more ARP replies on a specific cable interface than a specified minimum number of packets, use the **show cable arp-filter replies-filtered** command where *number* is the threshold value for the number of packets being generated:

**Example:**

```
show cable arp-filter cable interface requests-filtered number
```

For example, to display the devices that have generated more than 200 ARP reply packets, enter the following command:

**Example:**

```
Router# show cable arp-filter cable 5/0/0 replies-filtered 200
```

| Sid | MAC Address    | IP Address  | Req-Filtered | Req-For-IP-Filtered | Rep-Filtered |
|-----|----------------|-------------|--------------|---------------------|--------------|
| 2   | 0006.53b6.562f | 10.11.81.16 | 0            | 0                   | 2358         |
| 191 | 0100.f31c.990a | 10.11.81.6  | 0            | 0                   | 11290        |

**Step 4** (Optional) If a particular cable modem is generating or forwarding excessive ARP replies, contact the customer to see if they are using a Linksys Wireless-B Broadband Router, Model number BEFW11S4. If so, this router could be running old firmware that is incorrectly generating excessive ARP packets, and the customer should upgrade their firmware. For more information, see the [Linksys Wireless-Broadband Router \(BEFW11S4\)](#) guide

**Step 5** Repeat this command during each filter period (the time period you entered with the **cable arp filter** command) to show how quickly the devices are generating the ARP packets.

**Step 6** (Optional) The ARP reply and request packet counters are 16-bit counters, so if a very large number of packets are being generated on an interface, these counters could wrap around to zero in a few hours or even a few minutes. Clearing the ARP counters eliminates stale information from the display and makes it easier to see the worst offenders when you suspect ARP traffic is currently creating a problem on the network.

To eliminate the modems that are not currently triggering the ARP filters and to isolate the worst current offenders, use the **clear counters cable interface** command to reset all of the interface counters to zero. Then the **show cable arp-filter** commands clearly identify the SIDs of the modems that are currently forwarding the most ARP traffic.

For example, the following example indicates that a number of modems are forwarding a large enough volume of ARP traffic that they have triggered the ARP packet filters:

**Example:**

```
Router# show cable arp-filter cable 5/1/0 requests-filtered 10
```

| Sid | MAC Address    | IP Address | Req-Filtered | Req-For-IP-Filtered | Rep-Filtered |
|-----|----------------|------------|--------------|---------------------|--------------|
| 1   | 0006.2854.72d7 | 10.3.81.4  | 8            | 0                   | 0            |
| 23  | 0007.0e02.b747 | 10.3.81.31 | 32           | 0                   | 0            |
| 57  | 0007.0e03.2c51 | 10.3.81.31 | 12407        | 0                   | 0            |
| ... |                |            |              |                     |              |
| 81  | 00C0.c726.6b14 | 10.3.81.31 | 23           | 0                   | 0            |

SID 57 shows the largest number of packets, but it is not immediately apparent if this modem is causing the current problems. After clearing the counters though, the worst offenders are easily seen:

**Example:**

```
Router# clear counter cable 5/1/0

Clear show interface counters on this interface [confirm] y

08:17:53.968: %CLEAR-5-COUNTERS: Clear counter on interface Cable5/1/0 by console
Router# show cable arp cable 5/1/0

ARP Filter statistics for Cable3/0:
  Replies Rcvd: 0 total. 0 unfiltered, 0 filtered
  Requests Sent For IP: 0 total. 0 unfiltered, 0 filtered
  Requests Forwarded: 0 total. 0 unfiltered, 0 filtered

Router# show cable arp-filter cable 5/1/0 requests-filtered 10

Sid  MAC Address      IP Address      Req-Filtered  Req-For-IP-Filtered  Rep-Filtered
Router# show cable arp-filter cable 5/1/0 requests-filtered 10

Sid  MAC Address      IP Address      Req-Filtered  Req-For-IP-Filtered  Rep-Filtered
57   0007.0e03.2c51  10.3.81.31     20            0                    0
81   00C0.c726.6b14  10.3.81.31     12            0                    0
Router# show cable arp-filter cable 5/1/0 requests-filtered 10

Sid  MAC Address      IP Address      Req-Filtered  Req-For-IP-Filtered  Rep-Filtered
57   0007.0e03.2c51  10.3.81.31     31            0                    0
81   00C0.c726.6b14  10.3.81.31     18            0                    0
```

**Step 7**

(Optional) If the Req-For-IP-Filtered column shows the majority of ARP packets, use the **show cable arp-filter ip-requests-filtered** command to display more details about the CPE device that is generating this traffic. Then use the **debug cable mac-address** and **debug cable arp filter** commands to display detailed information about this particular traffic; for example:

**Example:**

```
Router# show cable arp-filter c5/0/0 ip-requests-filtered 100

Sid  MAC Address      IP Address      Req-Filtered  Req-For-IP-Filtered  Rep-Filtered
1    0007.0e03.1f59  50.3.81.3      0             37282                0
Router# debug cable mac-address 0007.0e03.1f59

Router# debug cable arp filter

Router#
Apr 23 23:03:23.565: ARP for IP Filter=F sid 1 s 0000.0000.0049 d 0005.00e5.3610 sip 50.3.81.13 dip
50.3.82.173 prot 6 len 46 SrcP 445 DstP 445
Apr 23 23:03:23.565: ARP for IP Filter=F sid 1 s 0000.0000.0049 d 0005.00e5.3610 sip 50.3.81.13 dip
50.3.82.174 prot 6 len 46 SrcP 445 DstP 445
Apr 23 23:03:23.565: ARP for IP Filter=F sid 1 s 0000.0000.0049 d 0005.00e5.3610 sip 50.3.81.13 dip
50.3.82.175 prot 6 len 46 SrcP 445 DstP 445
[additional output omitted]...
```

This example shows that the CPE device at IP address 50.3.81.13 is sending packets to TCP port 445 to every IP address on the 50.3.82.0 subnet, in a possible attempt to find a computer that has Microsoft Windows file-sharing enabled.

**Step 8** After determining the specific devices that are generating excessive ARP traffic, you can take whatever action is allowed by your company's service level agreements (SLAs) to correct the problem.

## Examples

In this example, two cable interfaces, C5/0/0 and C7/0/0, are joined in the same bundle, which means the interfaces share the same broadcast traffic. Separate devices on each interface are generating excessive ARP traffic:

- The device at MAC address 000C.2854.72D7 on interface C7/0/0 is generating or forwarding a large volume of ARP requests. Typically, this device is a cable modem that is forwarding the ARP requests that are being generated by a CPE device behind the modem. The CPE device could be attempting a theft-of-service or denial-of-service attack, or it could be a computer that has been infected by a virus and is trying to locate other computers that can be infected.
- The device at MAC address 000C.53B6.562F on Cable 5/0/0 is responding to a large number of ARP requests, which could indicate that the device is a router that is running faulty software.

The following commands identify the device on the C7/0/0 interface that is generating the excessive ARP requests:

```
Router# show cable arp-filter c7/0/0

ARP Filter statistics for Cable7/0/0:
  Replies Rcvd: 3 total. 3 unfiltered, 0 filtered
  Requests Sent For IP: 0 total. 0 unfiltered, 0 filtered
  Requests Forwarded: 27906 total. 562 unfiltered, 27344 filtered
Router# show cable arp-filter c7/0/0 requests-filtered 100

Sid  MAC Address      IP Address      Req-Filtered    Req-For-IP-Filtered  Rep-Filtered
1    000C.2854.72d7    50.3.81.4      62974           0                     0
```

The following commands identify the device on the C5/0/0 interface that is generating the excessive ARP replies:

```
Router# show cable arp-filter c5/0/0

ARP Filter statistics for Cable5/0/0:
  Replies Rcvd: 2400 total. 456 unfiltered, 1944 filtered
  Requests Sent For IP: 0 total. 0 unfiltered, 0 filtered
  Requests Forwarded: 26 total. 26 unfiltered, 0 filtered
Router# show cable arp-filter c5/0/0 replies-filtered 100

Sid  MAC Address      IP Address      Req-Filtered    Req-For-IP-Filtered  Rep-Filtered
2    000C.53b6.562f    50.3.81.6      0               0                     2097
```

## Clearing the Packet Counters

To clear the packet counters on an interface, which includes the ARP packet counters, use the **clear counters cable interface** command. You can also clear the packet counters on all interfaces by using the **clear counters** command without any options. This allows you to use the **show cable arp** commands to display only the CPE devices that are currently generating the most traffic.



**Note** The **clear counters** command clears all of the packet counters on an interface, not just the ARP packet counters.

## Identifying ARP Offenders in FP

When the FP ARP Filter feature is enabled, use the **show cable arp-filter interface** command to generate a list of ARP offenders.

### cBR-8 Outputs in FP

When the FP ARP Filter feature is enabled, the cBR-8 output formatting displays the modem and the CPE addresses on a single line, in addition to the following columns:

- **M/S**—This column shows if packets are being filtered by MAC address or SID. A majority of these columns will show MAC address.
- **Rate**—This column shows the packet rate for FP-filtered packets in the last 5 minutes monitoring time window. Rate is not calculated for RP-filtered packets.
- **Pro**—This column will identify the processor that performed the filtering with either “RP” or “FP.” On the cBR-8, it is expected that 99.9% of Pro fields will show “FP.”

The following is a sample output for an ARP request on a cBR-8 in FP:

```
Router# show cable arp-filter Bundle1 requests-filtered 40
Interface Cable5/0/0 - none
Interface Cable6/0/2
Sid  CPE Mac          CPE IP          Modem MAC       Modem IP       M/S Rate Pro REQS
4    00d0.b75a.822a 50.3.81.56      0007.0e03.9cad 50.3.81.15     MAC -   RP   46
4    00d0.b75a.822a 50.3.81.56      0007.0e03.9cad 50.3.81.15     MAC 25  FP  5012
5    00b0.d07c.e51d 50.3.81.57      0007.0e03.1f59 50.3.81.13     MAC -   RP  64000
6    -                -                0006.2854.7347 50.3.81.4      MAC 101 FP  5122
7    -                -                0006.2854.72d7 50.3.81.11     SID -   FP  961205
Interface Cable7/0/0 - none
```

This sample output demonstrates the following:

- SID 4 shows a CPE filtered in FP. The threshold specified is low enough to show the packets that were filtered on the RP as the offender was being identified. A high enough threshold would not have shown the RP-filtered packets. The ARP packet rate of 25 is shown for FP-filtered packets.
- SID 5 shows a CPE filtered on the RP. This is extremely unusual and only occurs when the maximum number of FP-filterable entities has been reached.
- SID 6 shows a modem filtered in FP (CPE MAC or CPE IP are not shown).
- SID 7 shows ARP packets from an “unknown” source MAC address filtered by SID in FP.

The counts for requests, replies, and requests for IP will no longer be shown on a single line in order to keep the line concise and less than 90 characters in length.

The “REQs” column is now stated as “REPs” in the case of ARP replies. The column will show “REQ-IP” in cases involving ARP requests for IP.

Requests being sent by the CMTS due to encroaching IP packets, “ip-requests-filtered”, will still be filtered on the RP and not in FP, with Access Control Lists (ACLs) used to defeat IP-based scanning traffic, and the IP punt rate limiting feature for cBR-8 used to decrease the punt rate for such traffic. The ARP Filter can still be used to perform analysis of these IP traffic streams.

# Configuration Examples for Cable ARP Filtering

This section provides the following examples of how to configure the Cable ARP Filtering features:

## ARP Filtering Configuration on an Individual Cable Interface: Example

The following example shows a typical configuration of a cable interface that is configured for the Cable ARP Filtering feature:

```
!
interface Cable5/0/0
 ip address 192.168.100.1 255.255.255.0 secondary
 ip address 192.168.110.13 255.255.255.0
 cable downstream annex B
 cable downstream modulation 256qam
 cable downstream interleave-depth 32
 cable downstream channel-id 0
 cable upstream 0 frequency 6000000
 cable upstream 0 power-level 0
 cable upstream 0 channel-width 3200000 200000
 cable upstream 0 minislot-size 16
 cable upstream 0 modulation-profile 6 7
 no cable upstream 0 shutdown
 cable upstream 1 frequency 26000000
 cable upstream 1 power-level 0
 cable upstream 1 channel-width 3200000 200000
 cable upstream 1 minislot-size 4
 cable upstream 1 modulation-profile 6 7
 no cable upstream 1 shutdown
 cable upstream 2 frequency 15008000
 cable upstream 2 power-level 0
 cable upstream 2 channel-width 3200000 200000
 cable upstream 2 minislot-size 4
 cable upstream 2 modulation-profile 6 7
 cable upstream 2 shutdown
 cable upstream 3 spectrum-group 25
 cable upstream 3 channel-width 3200000 200000
 cable upstream 3 minislot-size 4
 cable upstream 3 modulation-profile 1
 cable upstream 3 shutdown
 cable upstream 4 frequency 21008000
 cable upstream 4 power-level 0
 cable upstream 4 channel-width 3200000 200000
 cable upstream 4 minislot-size 16
 cable upstream 4 modulation-profile 1
 no cable upstream 4 shutdown
 cable upstream 5 spectrum-group 25
 cable upstream 5 channel-width 3200000 200000
 cable upstream 5 minislot-size 4
 cable upstream 5 modulation-profile 1
 cable upstream 5 shutdown
 cable arp filter request-send 4 2
 cable arp filter reply-accept 4 2
end
```

## ARP Filtering Configuration on Bundled Cable Interfaces: Example

The following example shows a typical configuration of a cable interface bundle that is also using the Cable ARP Filtering feature. Both the primary and subordinate interface are configured separately, allowing you to configure the feature only on the particular interfaces that require it. In addition, you can configure the feature with different threshold values, allowing you to customize the feature for each interface's traffic patterns.

```
!  
interface Cable5/0/0  
  description Master cable interface  
  ip address 10.3.130.1 255.255.255.0 secondary  
  ip address 10.3.131.1 255.255.255.0 secondary  
  ip address 10.3.132.1 255.255.255.0 secondary  
  ip address 10.3.133.1 255.255.255.0 secondary  
  ip address 10.3.81.1 255.255.255.0  
  ip helper-address 10.14.0.4  
  load-interval 30  
  cable bundle 1 master  
  cable downstream annex B  
  cable downstream modulation 64qam  
  cable downstream interleave-depth 32  
  cable downstream frequency 441000000  
  cable downstream channel-id 0  
  cable upstream 0 frequency 5008000  
  cable upstream 0 power-level 0  
  cable upstream 0 channel-width 1600000  
  cable upstream 0 minislots-size 4  
  cable upstream 0 modulation-profile 1  
  no cable upstream 0 shutdown  
  cable upstream 1 channel-width 1600000  
  cable upstream 1 minislots-size 4  
  cable upstream 1 modulation-profile 1  
  cable upstream 1 shutdown  
  cable upstream 2 channel-width 1600000  
  cable upstream 2 minislots-size 4  
  cable upstream 2 modulation-profile 1  
  cable upstream 2 shutdown  
  cable upstream 3 channel-width 1600000  
  cable upstream 3 minislots-size 4  
  cable upstream 3 modulation-profile 1  
  cable upstream 3 shutdown  
  cable arp filter request-send 4 2  
  cable arp filter reply-accept 4 2  
!  
interface Cable7/0/0  
  description Slave cable interface--Master is C5/0/0  
  no ip address  
  cable bundle 1  
  cable downstream annex B  
  cable downstream modulation 64qam  
  cable downstream interleave-depth 32  
  cable downstream frequency 562000000  
  cable downstream channel-id 0  
  no cable downstream rf-shutdown  
  cable upstream 0 connector 0  
  cable upstream 0 frequency 5008000  
  cable upstream 0 power-level 0  
  cable upstream 0 channel-width 1600000  
  cable upstream 0 minislots-size 4  
  cable upstream 0 modulation-profile 21  
  no cable upstream 0 shutdown  
  cable upstream 1 connector 1
```

```

cable upstream 1 channel-width 1600000
cable upstream 1 minislots-size 4
cable upstream 1 modulation-profile 21
cable upstream 1 shutdown
cable upstream 2 connector 2
cable upstream 2 channel-width 1600000
cable upstream 2 minislots-size 4
cable upstream 2 modulation-profile 21
cable upstream 2 shutdown
cable upstream 3 connector 3
cable upstream 3 channel-width 1600000
cable upstream 3 minislots-size 4
cable upstream 3 modulation-profile 21
cable upstream 3 shutdown
cable arp filter request-send 20 5
cable arp filter reply-accept 20 5
end

```

## ARP Filtering in FP Default Configuration: Example

The following example shows the default configuration of a cable interface for the ARP Filtering in FP feature.

```

interface Bundle1
  cable arp filter request-send 3 2
  cable arp filter reply-accept 3 2
end

```

## Additional References

The following sections provide references related to the Cable ARP Filtering feature.

### Technical Assistance

| Description                                                                                                                                                                                                                                                                                                                                                                           | Link                                                                                                                                                                                                                                                                                      |
|---------------------------------------------------------------------------------------------------------------------------------------------------------------------------------------------------------------------------------------------------------------------------------------------------------------------------------------------------------------------------------------|-------------------------------------------------------------------------------------------------------------------------------------------------------------------------------------------------------------------------------------------------------------------------------------------|
| The Cisco Support and Documentation website provides online resources to download documentation, software, and tools. Use these resources to install and configure the software and to troubleshoot and resolve technical issues with Cisco products and technologies. Access to most tools on the Cisco Support and Documentation website requires a Cisco.com user ID and password. | <a href="http://www.cisco.com/cisco/web/support/index.html">http://www.cisco.com/cisco/web/support/index.html</a>                                                                                                                                                                         |
| Source-Based Rate Limit                                                                                                                                                                                                                                                                                                                                                               | <a href="http://www.cisco.com/c/en/us/td/docs/cable/cbr/configuration/guide/b_cmts_sec_and_cable_mon_features_cbr/source-based_rate_limit.html">http://www.cisco.com/c/en/us/td/docs/cable/cbr/configuration/guide/b_cmts_sec_and_cable_mon_features_cbr/source-based_rate_limit.html</a> |
| <b>show platform hardware qfp active infrastructure punt summary</b> command                                                                                                                                                                                                                                                                                                          | <a href="http://www.cisco.com/c/en/us/td/docs/cable/cmts/cmd_ref/b_cmts_cable_cmd_ref/b_cmts_cable_cmd_ref_chapter_010100.html">http://www.cisco.com/c/en/us/td/docs/cable/cmts/cmd_ref/b_cmts_cable_cmd_ref/b_cmts_cable_cmd_ref_chapter_010100.html</a>                                 |



## Feature Information for Cable ARP Filtering

Use Cisco Feature Navigator to find information about the platform support and software image support. Cisco Feature Navigator enables you to determine which software images support a specific software release, feature set, or platform. To access Cisco Feature Navigator, go to the <https://cfng.cisco.com/> link. An account on the Cisco.com page is not required.



**Note** The following table lists the software release in which a given feature is introduced. Unless noted otherwise, subsequent releases of that software release train also support that feature.

*Table 324: Feature Information for the Cable ARP Filtering Feature*

| Feature Name        | Releases                    | Feature Information                                                                                               |
|---------------------|-----------------------------|-------------------------------------------------------------------------------------------------------------------|
| Cable ARP Filtering | Cisco IOS XE Everest 16.6.1 | This feature was integrated into Cisco IOS XE Everest 16.6.1 on the Cisco cBR Series Converged Broadband Routers. |





## CHAPTER 104

# Subscriber Management Packet Filtering Extension for DOCSIS 2.0

---

The Cisco converged broadband router supports management of data packet filtering based on the subscriber's preferences and criteria. Packet filtering enhances security to the cable network by allowing only the specific packets to flow to the Customer Premise Equipment (CPE) while dropping the unwanted data packets from the cable network.

Your software release may not support all the features that are documented in this module. For the latest feature information and caveats, see the release notes for your platform and software release. The Feature Information Table at the end of this document provides information about the documented features and lists the releases in which each feature is supported.

Use Cisco Feature Navigator to find information about platform support and Cisco software image support. To access Cisco Feature Navigator, go to <http://tools.cisco.com/ITDIT/CFN/>. An account on <http://www.cisco.com/> is not required.

### Contents

- [Hardware Compatibility Matrix for the Cisco cBR Series Routers](#), on page 1655
- [Prerequisites for Configuring Subscriber Management Packet Filtering](#), on page 1657
- [Restriction for Configuring Subscriber Management Packet Filtering](#), on page 1657
- [Information About Configuring Subscriber Management Packet Filtering](#), on page 1657
- [How to Configure Subscriber Management Packet Filtering](#), on page 1658
- [Configuration Examples for Subscriber Management Packet Filtering](#), on page 1661
- [Additional References](#), on page 1662
- [Feature Information for Subscriber Management Packet Filtering](#), on page 1662

## Hardware Compatibility Matrix for the Cisco cBR Series Routers



---

**Note** The hardware components that are introduced in a given Cisco IOS-XE Release are supported in all subsequent releases unless otherwise specified.

---

Table 325: Hardware Compatibility Matrix for the Cisco cBR Series Routers

| Cisco CMTS Platform                    | Processor Engine                                                                                                                                                                                  | Interface Cards                                                                                                                                                                                                                                                                                                                                                                                                                                                                                                                                                                                                                                                                                                                                                                                 |
|----------------------------------------|---------------------------------------------------------------------------------------------------------------------------------------------------------------------------------------------------|-------------------------------------------------------------------------------------------------------------------------------------------------------------------------------------------------------------------------------------------------------------------------------------------------------------------------------------------------------------------------------------------------------------------------------------------------------------------------------------------------------------------------------------------------------------------------------------------------------------------------------------------------------------------------------------------------------------------------------------------------------------------------------------------------|
| Cisco cBR-8 Converged Broadband Router | <p><b>Cisco IOS-XE Release 16.5.1 and Later Releases</b></p> <p>Cisco cBR-8 Supervisor:</p> <ul style="list-style-type: none"> <li>• PID—CBR-SUP-250G</li> <li>• PID—CBR-CCAP-SUP-160G</li> </ul> | <p><b>Cisco IOS-XE Release 16.5.1 and Later Releases</b></p> <p>Cisco cBR-8 CCAP Line Cards:</p> <ul style="list-style-type: none"> <li>• PID—CBR-LC-8D30-16U30</li> <li>• PID—CBR-LC-8D31-16U30</li> <li>• PID—CBR-RF-PIC</li> <li>• PID—CBR-RF-PROT-PIC</li> <li>• PID—CBR-CCAP-LC-40G</li> <li>• PID—CBR-CCAP-LC-40G-R</li> <li>• PID—CBR-CCAP-LC-G2-R</li> <li>• PID—CBR-SUP-8X10G-PIC</li> <li>• PID—CBR-2X100G-PIC</li> </ul> <p>Digital PICs:</p> <ul style="list-style-type: none"> <li>• PID—CBR-DPIC-8X10G</li> <li>• PID—CBR-DPIC-2X100G</li> </ul> <p>Cisco cBR-8 Downstream PHY Module:</p> <ul style="list-style-type: none"> <li>• PID—CBR-D31-DS-MOD</li> </ul> <p>Cisco cBR-8 Upstream PHY Modules:</p> <ul style="list-style-type: none"> <li>• PID—CBR-D31-US-MOD</li> </ul> |



**Note** Do not use DPICs (8X10G and 2x100G) to forward IP traffic, as it may cause buffer exhaustion, leading to line card reload.

The only allowed traffic on a DPIC interface is DEPI, UEPI, and GCP traffic from the Cisco cBR-8 router to Remote PHY devices. Other traffic such as DHCP, SSH, and UTSC should flow via another router, since DPICs cannot be used for normal routing.

# Prerequisites for Configuring Subscriber Management Packet Filtering

The software prerequisites for the subscriber management packet filtering feature are:

- The latest software image is loaded and working on the Cable Modem Termination System (CMTS) and the cable modems (CM).
- The configuration information on the main supervisor (SUP) and the standby SUP should be the same before the switchover.

## Restriction for Configuring Subscriber Management Packet Filtering

- This feature can define up to 254 filtering groups. The number of filters in each group is 255.

## Information About Configuring Subscriber Management Packet Filtering

A filter group specifies what filters are applied to the packets going to or coming from each specific CM or CPE device. It defines the rules or criteria to filter or drop a packet. Every packet that has to be filtered can either be accepted to send or filtered to be dropped. The criteria to filter a packet depends on the subscriber's preferences. The filter group can be applied to different subscriber management groups.

Cable subscriber management can be established using the following configuration methods:

- CMTS router configuration (via CLI)
- SNMP configuration

The process of configuring the subscriber management packet filtering is:

1. The packet filter group defines the action for a packet. The packet can be let to go to the CPE or dropped off the cable network based on the subscriber's packet criteria.
2. The CM sends a registration request to the CMTS. The registration request contains provisioning information that defines the association of a Packet Filtering Group (PFG) with the CM and its subscribers.
3. The specific downstream or upstream PFGs are used to bind the CM, CPE, embedded Multimedia Terminal Adaptor (eMTA), embedded Set-Top Box (eSTB) and embedded portal server (ePS) to a specific PFG.
4. The CMTS identifies the CPE device based on the CPE's DHCP information.



---

**Note** For the filter group to work for CMs, a CM must re-register after the CMTS router is configured.

---

# How to Configure Subscriber Management Packet Filtering

This section describes the configuration tasks that are performed to manage subscriber packet filtering on the Cisco CMTS platforms. You can use the command-line interface (CLI) commands to complete the configuration.

## Configuring the Filter Group

This section describes the tasks to configure the packet filter group. Follow the summary steps to complete the configuration.

To create, configure, and activate a DOCSIS filter group that filters packets on the basis of the TCP/IP and UDP/IP headers, use the cable filter group command in global configuration mode.

### Procedure

|               | Command or Action                                                                                                                                                                | Purpose                                                                        |
|---------------|----------------------------------------------------------------------------------------------------------------------------------------------------------------------------------|--------------------------------------------------------------------------------|
| <b>Step 1</b> | <p><b>enable</b></p> <p><b>Example:</b></p> <pre>Router&gt; enable</pre> <p><b>Example:</b></p> <pre>Router#</pre>                                                               | Enables privileged EXEC mode. Enter your password if prompted.                 |
| <b>Step 2</b> | <p><b>configure terminal</b></p> <p><b>Example:</b></p> <pre>Router# configure terminal</pre> <p><b>Example:</b></p> <pre>Router(config)#</pre>                                  | Enters global configuration mode.                                              |
| <b>Step 3</b> | <p><b>cable filter group group-id index index-num [option option-value]</b></p> <p><b>Example:</b></p> <pre>Router(config)# cable filter group 10 index 10 src-ip 10.7.7.7</pre> | Creates, configures, and activates a DOCSIS filter group that filters packets. |

## Defining the Upstream and Downstream MTA Filter Group

This section describes the configuration tasks to define the upstream and downstream subscriber management filter groups for an embedded Multimedia Terminal Adaptor (eMTA.) Follow the summary steps to complete the configuration.

### Procedure

|        | Command or Action                                                                                                                                                                 | Purpose                                                                                                            |
|--------|-----------------------------------------------------------------------------------------------------------------------------------------------------------------------------------|--------------------------------------------------------------------------------------------------------------------|
| Step 1 | <b>enable</b><br><b>Example:</b><br>Router> <b>enable</b>                                                                                                                         | Enables privileged EXEC mode. <ul style="list-style-type: none"> <li>• Enter your password if prompted.</li> </ul> |
| Step 2 | <b>configure terminal</b><br><b>Example:</b><br>Router# <b>configure terminal</b>                                                                                                 | Enters global configuration mode.                                                                                  |
| Step 3 | <b>cable submgmt default filter-group mta {downstream   upstream} group-id</b><br><b>Example:</b><br>Router(config)# <b>cable submgmt default filter-group mta downstream 130</b> | Defines the upstream and downstream subscriber management filter groups for an MTA.                                |

## Defining the Upstream and Downstream STB Filter Group

This section describes the configuration tasks to define the upstream and downstream subscriber management filter groups for a Set-Top Box (STB.) Follow the summary steps to complete the configuration.

### Procedure

|        | Command or Action                                                                 | Purpose                                                                                                            |
|--------|-----------------------------------------------------------------------------------|--------------------------------------------------------------------------------------------------------------------|
| Step 1 | <b>enable</b><br><b>Example:</b><br>Router> <b>enable</b>                         | Enables privileged EXEC mode. <ul style="list-style-type: none"> <li>• Enter your password if prompted.</li> </ul> |
| Step 2 | <b>configure terminal</b><br><b>Example:</b><br>Router# <b>configure terminal</b> | Enters global configuration mode.                                                                                  |

|               | Command or Action                                                                                                                                                                     | Purpose                                                                             |
|---------------|---------------------------------------------------------------------------------------------------------------------------------------------------------------------------------------|-------------------------------------------------------------------------------------|
| <b>Step 3</b> | <p>cable submgmt default filter-group stb {downstream   upstream} group-id</p> <p><b>Example:</b></p> <pre>Router(config)# cable submgmt default filter-group stb downstream 20</pre> | Defines the upstream and downstream subscriber management filter groups for an STB. |

## Defining the Upstream and Downstream PS Filter Group

This section describes the configuration tasks to define the upstream and downstream subscriber management filter groups for a Portal Server (PS.) Follow the summary steps to complete the configuration.

### Procedure

|               | Command or Action                                                                                                                                                                   | Purpose                                                                                      |
|---------------|-------------------------------------------------------------------------------------------------------------------------------------------------------------------------------------|----------------------------------------------------------------------------------------------|
| <b>Step 1</b> | <p><b>enable</b></p> <p><b>Example:</b></p> <pre>Router&gt; enable</pre> <p><b>Example:</b></p> <pre>Router#</pre>                                                                  | Enables privileged EXEC mode. Enter your password if prompted.                               |
| <b>Step 2</b> | <p><b>configure terminal</b></p> <p><b>Example:</b></p> <pre>Router# configure terminal</pre> <p><b>Example:</b></p> <pre>Router(config)#</pre>                                     | Enters global configuration mode.                                                            |
| <b>Step 3</b> | <p>cable submgmt default filter-group ps {downstream   upstream} group-id</p> <p><b>Example:</b></p> <pre>Router(config)# cable submgmt default filter-group ps downstream 10</pre> | Defines the upstream and downstream subscriber management filter groups for a portal server. |



# Configuration Examples for Subscriber Management Packet Filtering

This section describes a sample configuration example for configuring the subscriber management packet filtering.

## Configuring the Filter Group: Example

The following example shows configuration of a filter group that drops packets with a source IP address of 10.7.7.7 and a destination IP address of 10.8.8.8, and a source port number of 2000 and a destination port number of 3000. All protocol types and ToS and TCP flag values are matched:

```
Router(config)# cable filter group 10 index 10 src-ip 10.7.7.7
Router(config)# cable filter group 10 index 10 src-mask 255.255.0.0
Router(config)# cable filter group 10 index 10 dest-ip 10.8.8.8
Router(config)# cable filter group 10 index 10 dest-mask 255.255.0.0
Router(config)# cable filter group 10 index 10 ip-proto 256
Router(config)# cable filter group 10 index 10 src-port 2000
Router(config)# cable filter group 10 index 10 dest-port 3000
Router(config)# cable filter group 10 index 10 tcp-flags 0 0
Router(config)# cable filter group 10 index 10 match-action drop
```

## Defining the Upstream and Downstream MTA Filter Group: Example

The following example shows configuration of an upstream and downstream MTA filter group.

```
Router# configure terminal
Router(config)# cable submgmt default filter-group mta downstream 10
```

## Defining the Upstream and Downstream STB Filter Group: Example

The following example shows configuration of an upstream and downstream STB filter group.

```
Router#configure terminal
Router(config)#cable submgmt default filter-group stb downstream 20
```

## Defining the Upstream and Downstream PS Filter Group: Example

The following example shows configuration of an upstream and downstream portal server filter group.

```
Router#configure terminal
Router(config)#cable submgmt default filter-group ps downstream 10
```

## Additional References

The following sections provide references related to configuring the subscriber management packet filtering feature.

### Technical Assistance

| Description                                                                                                                                                                                                                                                                                                                                                                                                                                                                                                                                                             | Link                                                                            |
|-------------------------------------------------------------------------------------------------------------------------------------------------------------------------------------------------------------------------------------------------------------------------------------------------------------------------------------------------------------------------------------------------------------------------------------------------------------------------------------------------------------------------------------------------------------------------|---------------------------------------------------------------------------------|
| <p>The Cisco Support website provides extensive online resources, including documentation and tools for troubleshooting and resolving technical issues with Cisco products and technologies.</p> <p>To receive security and technical information about your products, you can subscribe to various services, such as the Product Alert Tool (accessed from Field Notices), the Cisco Technical Services Newsletter, and Really Simple Syndication (RSS) Feeds.</p> <p>Access to most tools on the Cisco Support website requires a Cisco.com user ID and password.</p> | <a href="http://www.cisco.com/techsupport">http://www.cisco.com/techsupport</a> |

## Feature Information for Subscriber Management Packet Filtering

Use Cisco Feature Navigator to find information about the platform support and software image support. Cisco Feature Navigator enables you to determine which software images support a specific software release, feature set, or platform. To access Cisco Feature Navigator, go to the <https://cfng.cisco.com/> link. An account on the Cisco.com page is not required.



**Note** The following table lists the software release in which a given feature is introduced. Unless noted otherwise, subsequent releases of that software release train also support that feature.

**Table 326: Feature Information for Subscriber Management Packet Filtering**

| Feature Name                           | Releases                    | Feature Information                                                                                             |
|----------------------------------------|-----------------------------|-----------------------------------------------------------------------------------------------------------------|
| Subscriber management packet filtering | Cisco IOS XE Everest 16.6.1 | This feature was integrated into Cisco IOS XE Everest 16.6.1 on the Cisco cBR Series Converged Broadband Router |



## CHAPTER 105

# MAC Filtering

---

This feature enables/disables MAC address filter on the backhaul interface.

Your software release may not support all the features that are documented in this module. For the latest feature information and caveats, see the release notes for your platform and software release. The Feature Information Table at the end of this document provides information about the documented features and lists the releases in which each feature is supported.

Use Cisco Feature Navigator to find information about platform support and Cisco software image support. To access Cisco Feature Navigator, go to <http://tools.cisco.com/ITDIT/CFN/>. An account on <http://www.cisco.com/> is not required.

### Contents

- [Hardware Compatibility Matrix for the Cisco cBR Series Routers, on page 1663](#)
- [Information About MAC Filtering, on page 1665](#)
- [How to Configure MAC Filtering, on page 1665](#)
- [Configuration Examples for MAC Filtering, on page 1668](#)
- [Feature Information for MAC Filtering, on page 1668](#)

## Hardware Compatibility Matrix for the Cisco cBR Series Routers



---

**Note** The hardware components that are introduced in a given Cisco IOS-XE Release are supported in all subsequent releases unless otherwise specified.

---

Table 327: Hardware Compatibility Matrix for the Cisco cBR Series Routers

| Cisco CMTS Platform                    | Processor Engine                                                                                                                                                                                  | Interface Cards                                                                                                                                                                                                                                                                                                                                                                                                                                                                                                                                                                                                                                                                                                                                                                                 |
|----------------------------------------|---------------------------------------------------------------------------------------------------------------------------------------------------------------------------------------------------|-------------------------------------------------------------------------------------------------------------------------------------------------------------------------------------------------------------------------------------------------------------------------------------------------------------------------------------------------------------------------------------------------------------------------------------------------------------------------------------------------------------------------------------------------------------------------------------------------------------------------------------------------------------------------------------------------------------------------------------------------------------------------------------------------|
| Cisco cBR-8 Converged Broadband Router | <p><b>Cisco IOS-XE Release 16.5.1 and Later Releases</b></p> <p>Cisco cBR-8 Supervisor:</p> <ul style="list-style-type: none"> <li>• PID—CBR-SUP-250G</li> <li>• PID—CBR-CCAP-SUP-160G</li> </ul> | <p><b>Cisco IOS-XE Release 16.5.1 and Later Releases</b></p> <p>Cisco cBR-8 CCAP Line Cards:</p> <ul style="list-style-type: none"> <li>• PID—CBR-LC-8D30-16U30</li> <li>• PID—CBR-LC-8D31-16U30</li> <li>• PID—CBR-RF-PIC</li> <li>• PID—CBR-RF-PROT-PIC</li> <li>• PID—CBR-CCAP-LC-40G</li> <li>• PID—CBR-CCAP-LC-40G-R</li> <li>• PID—CBR-CCAP-LC-G2-R</li> <li>• PID—CBR-SUP-8X10G-PIC</li> <li>• PID—CBR-2X100G-PIC</li> </ul> <p>Digital PICs:</p> <ul style="list-style-type: none"> <li>• PID—CBR-DPIC-8X10G</li> <li>• PID—CBR-DPIC-2X100G</li> </ul> <p>Cisco cBR-8 Downstream PHY Module:</p> <ul style="list-style-type: none"> <li>• PID—CBR-D31-DS-MOD</li> </ul> <p>Cisco cBR-8 Upstream PHY Modules:</p> <ul style="list-style-type: none"> <li>• PID—CBR-D31-US-MOD</li> </ul> |



**Note** Do not use DPICs (8X10G and 2x100G) to forward IP traffic, as it may cause buffer exhaustion, leading to line card reload.

The only allowed traffic on a DPIC interface is DEPI, UEPI, and GCP traffic from the Cisco cBR-8 router to Remote PHY devices. Other traffic such as DHCP, SSH, and UTSC should flow via another router, since DPICs cannot be used for normal routing.

## Information About MAC Filtering

With this feature, only the packet whose destination MAC address is the MAC address of the router interface can be forwarded. It supports 32 unicast filter entries per interface. It is disabled by default.



---

**Note** When port-channel is enabled, MAC filtering must be enabled on backhaul interface to take effect.

---



---

**Note** When both dot1q l2vpn and MAC filtering are enabled on backhaul interface, only 1 unicast filter entry is supported per backhaul interface. The MAC filtering is only supported for non-l2vpn unicast packets.

---

## How to Configure MAC Filtering

This section describes the configuration tasks that are performed to manage MAC filtering. You can use the command-line interface (CLI) commands to complete the configuration.

### Configuring MAC Filtering

To configure MAC filtering, follow the steps below:

```
enable
configure terminal
interface tenGigabitEthernet slot/subslot/port
mac-addr-filter
end
```

### Verifying MAC Filtering

To verify the MAC filtering configuration on the backhaul interface, use **show running-config interface** command as shown below:

```
Router# show running-config interface tenGigabitEthernet 4/1/0
Building configuration...

Current configuration : 73 bytes
!
interface TenGigabitEthernet4/1/0
 no ip address
 mac-addr-filter
end
```

To verify the MAC filtering status on a specific SUP slot and SUP-PIC bay, use **show platform software iomd** command as shown below:

```
Router# show platform software iomd 4/4 mac-filter
IOMD (Input Output Module Driver) Mac Filter Status
```

```

port: 0      promiscuous mode:  unicast:  enable  multicast:  enable  broadcast:
enable
0           Input Drop cnt:                0          Total Drop cnt:
0           Entry Number:  1
Index      Mode  Action                Entry MAC                Entry MASK                Match
Count
000       enable  pass  c4:14:3c:16:7c:04  ff:ff:ff:ff:ff:ff
0

port: 1      promiscuous mode:  unicast:  enable  multicast:  enable  broadcast:
enable
0           Input Drop cnt:                0          Total Drop cnt:
0           Entry Number:  1
Index      Mode  Action                Entry MAC                Entry MASK                Match
Count
000       enable  pass  c4:14:3c:16:7c:05  ff:ff:ff:ff:ff:ff
1729

port: 2      promiscuous mode:  unicast:  enable  multicast:  enable  broadcast:
enable
0           Input Drop cnt:                0          Total Drop cnt:
0           Entry Number:  1
Index      Mode  Action                Entry MAC                Entry MASK                Match
Count
000       enable  pass  c4:14:3c:16:7c:06  ff:ff:ff:ff:ff:ff
0

port: 3      promiscuous mode:  unicast:  enable  multicast:  enable  broadcast:
enable
0           Input Drop cnt:                0          Total Drop cnt:
0           Entry Number:  1
Index      Mode  Action                Entry MAC                Entry MASK                Match
Count
000       enable  pass  c4:14:3c:16:7c:07  ff:ff:ff:ff:ff:ff
0

port: 4      promiscuous mode:  unicast:  enable  multicast:  enable  broadcast:
enable
0           Input Drop cnt:                0          Total Drop cnt:
0           Entry Number:  1
Index      Mode  Action                Entry MAC                Entry MASK                Match
Count
000       enable  pass  c4:14:3c:16:7c:08  ff:ff:ff:ff:ff:ff
0

port: 5      promiscuous mode:  unicast:  enable  multicast:  enable  broadcast:
enable
0           Input Drop cnt:                0          Total Drop cnt:
0           Entry Number:  1
Index      Mode  Action                Entry MAC                Entry MASK                Match
Count

```

```

    00    enable    pass    c4:14:3c:16:7c:09    ff:ff:ff:ff:ff:ff
  15

port: 6    promiscuous mode:    unicast: enable    multicast: enable    broadcast:
enable

    Input Drop cnt:    0    Total Drop cnt:
    0

    Entry Number:    1
Index      Mode    Action    Entry MAC    Entry MASK    Match
Count
    00    enable    pass    c4:14:3c:16:7c:0a    ff:ff:ff:ff:ff:ff
    0

port: 7    promiscuous mode:    unicast: enable    multicast: enable    broadcast:
enable

    Input Drop cnt:    0    Total Drop cnt:
    0

    Entry Number:    1
Index      Mode    Action    Entry MAC    Entry MASK    Match
Count
    00    enable    pass    c4:14:3c:16:7c:0b    ff:ff:ff:ff:ff:ff
    0

```

If the MAC filtering is disabled, the output of the **show platform software iomd** command is shown as below:

```

Router# show platform software iomd 4/5 mac-filter
IOMD (Input Output Module Driver) MAC filter Status

```

```

port: 0    promiscuous mode:    unicast: enable    multicast: enable    broadcast:
enable

    Input Drop cnt:    0    Total Drop cnt:
    0

    Entry Number:    0

port: 1    promiscuous mode:    unicast: enable    multicast: enable    broadcast:
enable

    Input Drop cnt:    0    Total Drop cnt:
    0

    Entry Number:    0

port: 2    promiscuous mode:    unicast: enable    multicast: enable    broadcast:
enable

    Input Drop cnt:    0    Total Drop cnt:
    0

    Entry Number:    0

port: 3    promiscuous mode:    unicast: enable    multicast: enable    broadcast:
enable

    Input Drop cnt:    0    Total Drop cnt:
    0

    Entry Number:    0

port: 4    promiscuous mode:    unicast: enable    multicast: enable    broadcast:
enable

    Input Drop cnt:    0    Total Drop cnt:
    0

```

```

Entry Number: 0

port: 5 promiscuous mode: unicast: enable multicast: enable broadcast:
enable
Input Drop cnt: 0 Total Drop cnt:
0
Entry Number: 0

port: 6 promiscuous mode: unicast: enable multicast: enable broadcast:
enable
Input Drop cnt: 0 Total Drop cnt:
0
Entry Number: 0

port: 7 promiscuous mode: unicast: enable multicast: enable broadcast:
enable
Input Drop cnt: 0 Total Drop cnt:
0
Entry Number: 0

```

## Configuration Examples for MAC Filtering

This section describes a sample configuration example for configuring the MAC filtering.

```

router> enable
router# configure terminal
router(config)# interface tenGigabitEthernet 4/1/0
router(config-if)# mac-addr-filter
router(config-if)# end

```

## Feature Information for MAC Filtering

Use Cisco Feature Navigator to find information about the platform support and software image support. Cisco Feature Navigator enables you to determine which software images support a specific software release, feature set, or platform. To access Cisco Feature Navigator, go to the <https://cfngn.cisco.com/> link. An account on the Cisco.com page is not required.



**Note** The following table lists the software release in which a given feature is introduced. Unless noted otherwise, subsequent releases of that software release train also support that feature.

**Table 328: Feature Information for MAC Filtering**

| Feature Name  | Releases                    | Feature Information                                                                                               |
|---------------|-----------------------------|-------------------------------------------------------------------------------------------------------------------|
| MAC Filtering | Cisco IOS XE Everest 16.6.1 | This feature was integrated into Cisco IOS XE Everest 16.6.1 on the Cisco cBR Series Converged Broadband Routers. |





## PART **XIII**

# Troubleshooting and Network Management Configuration

- [Call Home, on page 1671](#)
- [Platform Automated Monitoring, on page 1737](#)
- [SNMP Support over VPNs—Context-Based Access Control, on page 1743](#)
- [SNMP Engine Enhancement, on page 1755](#)
- [Onboard Failure Logging, on page 1761](#)
- [Control Point Discovery, on page 1773](#)
- [IPDR Streaming Protocol, on page 1785](#)
- [Usage-Based Billing \(SAMIS\), on page 1797](#)
- [Frequency Allocation Information for the Cisco CMTS Routers, on page 1843](#)
- [Flap List Troubleshooting, on page 1855](#)
- [Maximum CPE and Host Parameters, on page 1875](#)
- [SNMP Background Synchronization, on page 1885](#)
- [Online Offline Diagnostics, on page 1897](#)
- [Factory Reset, on page 1901](#)





## CHAPTER 106

# Call Home

---

Call Home offers diagnostics and real-time alerts on select Cisco devices, which provide higher network availability and increased operational efficiency. Smart Call Home is a secure connected service of Cisco SMARTnet for the Cisco cBR routers.

Your software release may not support all the features that are documented in this module. For the latest feature information and caveats, see the release notes for your platform and software release. The Feature Information Table at the end of this document provides information about the documented features and lists the releases in which each feature is supported.

Use Cisco Feature Navigator to find information about platform support and Cisco software image support. To access Cisco Feature Navigator, go to <http://tools.cisco.com/ITDIT/CFN/>. An account on <http://www.cisco.com/> is not required.

### Contents

- [Hardware Compatibility Matrix for the Cisco cBR Series Routers, on page 1671](#)
- [Prerequisites for Call Home, on page 1673](#)
- [Restrictions for Call Home, on page 1673](#)
- [Information About Call Home, on page 1673](#)
- [How to Configure Call Home, on page 1676](#)
- [Configuring Diagnostic Signatures, on page 1698](#)
- [Verifying the Call Home Configuration, on page 1706](#)
- [Configuration Example for Call Home, on page 1710](#)
- [Default Settings, on page 1716](#)
- [Alert Groups Trigger Events and Commands, on page 1717](#)
- [Message Contents, on page 1721](#)
- [Additional References, on page 1734](#)
- [Feature Information for Call Home, on page 1735](#)

## Hardware Compatibility Matrix for the Cisco cBR Series Routers



---

**Note** The hardware components that are introduced in a given Cisco IOS-XE Release are supported in all subsequent releases unless otherwise specified.

---

Table 329: Hardware Compatibility Matrix for the Cisco cBR Series Routers

| Cisco CMTS Platform                    | Processor Engine                                                                                                                                                                                  | Interface Cards                                                                                                                                                                                                                                                                                                                                                                                                                                                                                                                                                                                                                                                                                                                                                                                 |
|----------------------------------------|---------------------------------------------------------------------------------------------------------------------------------------------------------------------------------------------------|-------------------------------------------------------------------------------------------------------------------------------------------------------------------------------------------------------------------------------------------------------------------------------------------------------------------------------------------------------------------------------------------------------------------------------------------------------------------------------------------------------------------------------------------------------------------------------------------------------------------------------------------------------------------------------------------------------------------------------------------------------------------------------------------------|
| Cisco cBR-8 Converged Broadband Router | <p><b>Cisco IOS-XE Release 16.5.1 and Later Releases</b></p> <p>Cisco cBR-8 Supervisor:</p> <ul style="list-style-type: none"> <li>• PID—CBR-SUP-250G</li> <li>• PID—CBR-CCAP-SUP-160G</li> </ul> | <p><b>Cisco IOS-XE Release 16.5.1 and Later Releases</b></p> <p>Cisco cBR-8 CCAP Line Cards:</p> <ul style="list-style-type: none"> <li>• PID—CBR-LC-8D30-16U30</li> <li>• PID—CBR-LC-8D31-16U30</li> <li>• PID—CBR-RF-PIC</li> <li>• PID—CBR-RF-PROT-PIC</li> <li>• PID—CBR-CCAP-LC-40G</li> <li>• PID—CBR-CCAP-LC-40G-R</li> <li>• PID—CBR-CCAP-LC-G2-R</li> <li>• PID—CBR-SUP-8X10G-PIC</li> <li>• PID—CBR-2X100G-PIC</li> </ul> <p>Digital PICs:</p> <ul style="list-style-type: none"> <li>• PID—CBR-DPIC-8X10G</li> <li>• PID—CBR-DPIC-2X100G</li> </ul> <p>Cisco cBR-8 Downstream PHY Module:</p> <ul style="list-style-type: none"> <li>• PID—CBR-D31-DS-MOD</li> </ul> <p>Cisco cBR-8 Upstream PHY Modules:</p> <ul style="list-style-type: none"> <li>• PID—CBR-D31-US-MOD</li> </ul> |



**Note** Do not use DPICs (8X10G and 2x100G) to forward IP traffic, as it may cause buffer exhaustion, leading to line card reload.

The only allowed traffic on a DPIC interface is DEPI, UEPI, and GCP traffic from the Cisco cBR-8 router to Remote PHY devices. Other traffic such as DHCP, SSH, and UTSC should flow via another router, since DPICs cannot be used for normal routing.

## Prerequisites for Call Home

- Contact email address (required for full registration with Smart Call Home, optional if Call Home is enabled in anonymous mode), phone number (optional), and street address information (optional) must be configured so that the receiver can determine the origin of messages received.



---

**Note** Contact email address is not required if you enable Smart Call Home by enabling smart licensing.

---

- At least one destination profile (predefined or user-defined) must be configured. The destination profiles configured depends on whether the receiving entity is a pager, email, or automated service such as Cisco Smart Call Home.
  - If the destination profile uses email message delivery, you must specify a Simple Mail Transfer Protocol (SMTP) server.
  - Configuring the trustpool certificate authority (CA) is not required for HTTPS server connection as the trustpool feature is enabled by default.
- The router must have IP connectivity to an email server or the destination HTTP(S) server.
- To use Cisco Smart Call Home service, you require an active service contract covering the device, which provides full Smart Call Home service.



---

**Note** An active service contract is only required for full Smart Call Home services like automatically raising a Cisco Technical Assistance Center (TAC) case.

---

## Restrictions for Call Home

- If there is no IP connectivity or if the interface in the VRF to the profile destination is down, Smart Call Home messages cannot be sent.
- Smart Call Home operates with any SMTP server.
- You can configure up to five SMTP servers for Smart Call Home.

## Information About Call Home

The Call Home feature provides email-based and web-based notification of critical system events. A versatile range of message formats are available for optimal compatibility with pager services, standard email, or XML-based automated parsing applications.

Common uses of this feature may include:

- Direct paging of a network support engineer
- Email notification to a network operations center
- XML delivery to a support website
- Use of Cisco Smart Call Home services for direct case generation with the Cisco Technical Assistance Center (TAC).

The Call Home feature can deliver alert messages containing information about configuration, environmental conditions, inventory, syslog, snapshot, and crash events.

The Call Home feature can deliver alerts to multiple recipients, which are seen as *Call Home destination profiles*, each with configurable message formats and content categories. A predefined destination profile (CiscoTAC-1) is provided, and you can also define your own destination profiles. The CiscoTAC-1 profile is used to send alerts to the backend server of the Smart Call Home service. It can be used to create service requests to Cisco TAC. This service depends on the Smart Call Home service support in place for your device and the severity of the alert.

Flexible message delivery and format options make it easy to integrate specific support requirements.

## Benefits of Call Home

- Automatic execution and attachment of the relevant CLI command output.
- Multiple message-format options such as the following:
  - Short Text—Suitable for pagers or printed reports.
  - Full Text—Fully formatted message information suitable for human reading.
  - XML—Matching readable format using Extensible Markup Language (XML). The XML format enables communication with the Cisco TAC.
- Multiple concurrent message destinations.
- Multiple message categories including configuration, crash, diagnostic, environment, inventory, snapshot, and syslog.
- Filtering of messages that are based on the severity and pattern matching.
- Scheduling of periodic message sending.

## Obtaining Smart Call Home Services

If you have a service contract directly with Cisco, you can register for the Smart Call Home service. Smart Call Home analyzes Smart Call Home messages and provides background information and recommendations. For critical issues, Automatic Service Requests are generated with the Cisco TAC.

Smart Call Home offers the following features:

- Continuous device health monitoring and real-time alerts.
- Analysis of Smart Call Home messages. Optional generation of the Automatic Service Request report, including detailed diagnostic information that speeds up the problem resolution, which is routed to the correct TAC team.

- Direct secure message transportation from your device, through an HTTP proxy server, or a downloadable Transport Gateway (TG). You can use a TG aggregation point to support multiple devices. Or, you can use it in scenario where security dictates that your devices may not be connected directly to the Internet.
- Web-based access that provides Smart Call Home messages and recommendations, inventory, and configuration information for all Smart Call Home devices. This access provides associated field notices, security advisories, and end-of-life information.

You need the following items to register for Smart Call Home:

- SMARTnet contract number for your router.
- Your email address
- Your Cisco.com username

For information about how to configure Call Home to work with the Smart Call Home service, see the [Cisco Smart Call Home Support Community](#) forum.

## Anonymous Reporting

Smart Call Home is a service capability that is included with many Cisco service contracts and is designed to assist you help resolve problems quickly. In addition, the information gained from crash messages helps Cisco understand equipment and issues occurring in the field. You can enable Anonymous Reporting without Smart Call Home. Anonymous Reporting allows Cisco to securely receive minimal error and health information from the device. If you enable Anonymous Reporting, your identity remains anonymous, and no identifying information is sent.



---

**Note** When you enable Anonymous Reporting, you acknowledge your consent to transfer specified data. The data is shared with Cisco or to vendors operating on behalf of Cisco (including countries outside the United States). Cisco maintains the privacy of all customers. For information about how Cisco treats personal information, see the Cisco Privacy Statement at [Cisco Online Privacy Statement](#).

---

When Call Home is configured in an anonymous way, only crash, inventory, and test messages are sent to Cisco. No identifying information is sent.

For more information about what is sent in these messages, see the Alert Group Trigger Events and Commands section.

## Smart Licensing

Smart Licensing uses the Smart Call Home service.

The Smart Licensing service is an alternative licensing architecture to Cisco Software Licensing (CSL). Smart Licensing uses the Cisco Smart Software Manager as a backend tool for managing licenses. Smart Call Home must be configured before using the Smart Licensing. By default, Smart Licensing and Smart Call Home are enabled on the Cisco cBR routers.

For more information about Smart Licensing, see the [Cisco Smart Licensing on the Cisco cBR Router](#) topic.

# How to Configure Call Home

## Configuring Smart Call Home (Single Command)

Smart Call Home is enabled by default on the router. The CiscoTAC-1 profile to send data to Cisco is also enabled by default.

Unless you change to anonymous mode or add HTTP proxy, the single command is not used to enable Smart Call Home on the router.

To enable all Call Home basic configurations using a single command, perform the following steps:

### SUMMARY STEPS

1. **configure terminal**
2. **call-home reporting** {**anonymous** | **contact-email-addr** *email-address*} [**http-proxy** {*ipv4-address* | *ipv6-address* | **name**} **port** *port number*]

### DETAILED STEPS

|        | Command or Action                                                                                                                                                                                                                                                                                                                        | Purpose                                                                                                                                                                                                                                                                                                                                                                                                                                                                                                                                                                                                                                                                                                                                                                                                                                                                                           |
|--------|------------------------------------------------------------------------------------------------------------------------------------------------------------------------------------------------------------------------------------------------------------------------------------------------------------------------------------------|---------------------------------------------------------------------------------------------------------------------------------------------------------------------------------------------------------------------------------------------------------------------------------------------------------------------------------------------------------------------------------------------------------------------------------------------------------------------------------------------------------------------------------------------------------------------------------------------------------------------------------------------------------------------------------------------------------------------------------------------------------------------------------------------------------------------------------------------------------------------------------------------------|
| Step 1 | <b>configure terminal</b><br><b>Example:</b><br>Device# <b>configure terminal</b>                                                                                                                                                                                                                                                        | Enters global configuration mode.                                                                                                                                                                                                                                                                                                                                                                                                                                                                                                                                                                                                                                                                                                                                                                                                                                                                 |
| Step 2 | <b>call-home reporting</b> { <b>anonymous</b>   <b>contact-email-addr</b> <i>email-address</i> } [ <b>http-proxy</b> { <i>ipv4-address</i>   <i>ipv6-address</i>   <b>name</b> } <b>port</b> <i>port number</i> ]<br><b>Example:</b><br>Device(config)# <b>call-home reporting</b><br><b>contact-email-addr</b> <i>email@company.com</i> | Enables all Call Home basic configurations using a single command. <ul style="list-style-type: none"> <li>• <b>anonymous</b>—Enables the Call-Home TAC profile to only send crash, inventory, test messages, and send the messages in an anonymous way.</li> <li>• <b>contact-email-addr</b>—Enables Smart Call Home service full reporting capability. The service also sends a full inventory message from the Call-Home TAC profile to the Smart Call Home server to start full registration process.</li> <li>• <b>http-proxy</b> {<i>ipv4-address</i>   <i>ipv6-address</i>   <b>name</b>—An IPv4 or IPv6 address or server name. Maximum length is 64.</li> <li>• <b>port</b> <i>port number</i>—Port number. Range is 1 to 65535.</li> </ul> <p><b>Note</b> HTTP proxy option allows you to set your own proxy server to buffer and secure the internet connections from your devices.</p> |



|  | Command or Action | Purpose                                                                                                                                                                                                                                                                                                                                                                                                                                                                                                                                        |
|--|-------------------|------------------------------------------------------------------------------------------------------------------------------------------------------------------------------------------------------------------------------------------------------------------------------------------------------------------------------------------------------------------------------------------------------------------------------------------------------------------------------------------------------------------------------------------------|
|  |                   | <p><b>Note</b> After successfully enabling Call Home either in anonymous or full registration mode using the <b>call-home reporting</b> command, an inventory message is sent out. If Call Home is enabled in anonymous mode, an anonymous inventory message is sent out. If Call Home is enabled in full registration mode, a Full Inventory message for full registration mode is sent. For more information about what is sent in these messages, see the <a href="#">Alert Groups Trigger Events and Commands, on page 1717</a> topic.</p> |

## Configuring Call Home

For security reasons, we recommend that you use the HTTPS transport options, due to the additional payload encryption that HTTPS offers. The Transport Gateway software is downloadable from Cisco.com and is available if you require an aggregation point or a proxy for connection to the Internet.

The implementation on the router supports the trustpool feature (embedded CA certificates in Cisco IOS images). The trustpool feature simplifies configuration to enable Smart Call Home service on configured devices. It eliminates the requirement of manually configuring the trustpool and provides the automatic update of the CA certificate, if it changes in the future.

## Enabling and Disabling Call Home

To enable or disable the Call Home feature, complete the following steps:

### SUMMARY STEPS

1. **configure terminal**
2. **service call-home**
3. **no service call-home**

### DETAILED STEPS

|                      | Command or Action                                                                                          | Purpose                                  |
|----------------------|------------------------------------------------------------------------------------------------------------|------------------------------------------|
| <p><b>Step 1</b></p> | <p><b>configure terminal</b></p> <p><b>Example:</b></p> <pre>Router# <b>configure terminal</b></pre>       | <p>Enters global configuration mode.</p> |
| <p><b>Step 2</b></p> | <p><b>service call-home</b></p> <p><b>Example:</b></p> <pre>Router(config)# <b>service call-home</b></pre> | <p>Enables the Call Home feature.</p>    |

|               | Command or Action                                                                               | Purpose                         |
|---------------|-------------------------------------------------------------------------------------------------|---------------------------------|
| <b>Step 3</b> | <b>no service call-home</b><br><b>Example:</b><br>Router (config) # <b>no service call-home</b> | Disables the Call Home feature. |

## Configuring Contact Information

Each router must include a contact email address. You can optionally include a phone number, street address, contract ID, customer ID, and site ID.

To assign the contact information, complete the following steps:

### SUMMARY STEPS

1. **configure terminal**
2. **call-home**
3. **contact-email-addr** *email-address*
4. **phone-number** *+phone-number*
5. **street-address** *street-address*
6. **customer-id** *text*
7. **site-id** *text*
8. **contract-id** *text*

### DETAILED STEPS

|               | Command or Action                                                                                                                                      | Purpose                                                                                                  |
|---------------|--------------------------------------------------------------------------------------------------------------------------------------------------------|----------------------------------------------------------------------------------------------------------|
| <b>Step 1</b> | <b>configure terminal</b><br><b>Example:</b><br>Router> <b>configure terminal</b>                                                                      | Enters global configuration mode.                                                                        |
| <b>Step 2</b> | <b>call-home</b><br><b>Example:</b><br>Router (config) # <b>call-home</b>                                                                              | Enters call home configuration mode.                                                                     |
| <b>Step 3</b> | <b>contact-email-addr</b> <i>email-address</i><br><b>Example:</b><br>Router (cfg-call-home) # <b>contact-email-addr</b><br><b>username@example.com</b> | Assigns the customer's email address. Enter up to 200 characters in email address format with no spaces. |
| <b>Step 4</b> | <b>phone-number</b> <i>+phone-number</i><br><b>Example:</b>                                                                                            | (Optional) Assigns the customer's phone number.                                                          |

|               | Command or Action                                                                                                                                                                       | Purpose                                                                                                                                                                                                                         |
|---------------|-----------------------------------------------------------------------------------------------------------------------------------------------------------------------------------------|---------------------------------------------------------------------------------------------------------------------------------------------------------------------------------------------------------------------------------|
|               | <pre>Router(cfg-call-home) # <b>phone-number</b> <b>+1-222-333-4444</b></pre>                                                                                                           | <p><b>Note</b> The number must start with a plus (+) prefix, and may contain only dashes (-) and numbers. Enter up to 16 characters. If you include spaces, you must enclose your entry within double quotation marks (“”).</p> |
| <b>Step 5</b> | <p><b>street-address</b> <i>street-address</i></p> <p><b>Example:</b></p> <pre>Router(cfg-call-home) # <b>street-address</b> "1234 <b>Any Street, Any city, Any state, 12345"</b></pre> | <p>(Optional) Assigns the customer’s street address where RMA equipment can be shipped. Enter up to 200 characters. If you include spaces, you must enclose your entry within double quotation marks (“”).</p>                  |
| <b>Step 6</b> | <p><b>customer-id</b> <i>text</i></p> <p><b>Example:</b></p> <pre>Router(cfg-call-home) # <b>customer-id</b> <b>Customer1234</b></pre>                                                  | <p>(Optional) Identifies the customer ID. Enter up to 64 characters. If you include spaces, you must enclose your entry within double quotation marks (“”).</p>                                                                 |
| <b>Step 7</b> | <p><b>site-id</b> <i>text</i></p> <p><b>Example:</b></p> <pre>Router(cfg-call-home) # <b>site-id</b> <b>SitelManhattanNY</b></pre>                                                      | <p>(Optional) Identifies the customer site ID. Enter up to 200 characters. If you include spaces, you must enclose your entry within double quotation marks (“”).</p>                                                           |
| <b>Step 8</b> | <p><b>contract-id</b> <i>text</i></p> <p><b>Example:</b></p> <pre>Router(cfg-call-home) # <b>contract-id</b> <b>Company1234</b></pre>                                                   | <p>(Optional) Identifies the customer’s contract ID for the router. Enter up to 64 characters. If you include spaces, you must enclose your entry within double quotation marks (“”).</p>                                       |

## Configuring Destination Profiles

A destination profile contains the required delivery information for an alert notification. At least one destination profile is required. You can configure multiple destination profiles of one or more types.

You can create and define a new destination profile or copy and use the predefined destination profile. If you define a new destination profile, you must assign a profile name. You can control which profile to be used for Smart Licensing by enabling or disabling smart-licensing data of that profile. Only one active profile can have a data enabled smart-license.



**Note** If you use the Smart Call Home service, the destination profile must use the XML message format.

A destination profile includes the following information:

- Profile name—String that uniquely identifies each user-defined destination profile. The profile name is limited to 31 characters and is not case-sensitive. You cannot use **all** as a profile name.

- Transport method—Transport mechanism, either email or HTTP (including HTTPS), for delivery of alerts.
  - For user-defined destination profiles, email is the default, and you can enable either or both transport mechanisms. If you disable both methods, email is enabled.
  - For the predefined CiscoTAC-1 profile, you can enable either transport mechanism, but not both.
- Destination address—The actual address that is related to the transport method by which the alert is sent. You can change the destination of the CiscoTAC-1 profile.
- Message formatting—The message format that is used for sending the alert. The format options for a user-defined destination profile are long-text, short-text, or XML. The default is XML. For the predefined CiscoTAC-1 profile, only XML is allowed.
- Message size—The maximum destination message size. The valid range is 50 to 3,145,728 bytes. The default is 3,145,728 bytes.
- Reporting method—You can choose which data to report for a profile. You can enable reporting of Smart Call Home data or Smart Licensing data, or both. Only one active profile is allowed to report Smart Licensing data at a time.
- Anonymous reporting—You can choose for your customer identity to remain anonymous, and no identifying information is sent.
- Subscribing to interesting alert-groups—You can choose to subscribe to alert-groups highlighting your interests.
- Message severity level—The Call Home severity level that the alert must meet before a Call Home message is generated. The Call Home message is then delivered to all email addresses in the destination profile. An alert is not generated if the Call Home severity level of the alert is lower than the message severity level set for the destination profile.

You can also configure a destination profile to allow periodic inventory update messages by using the inventory alert group.

A predefined destination profile CiscoTAC-1 is supported. It supports the XML message format. This profile is preconfigured with the Cisco Smart Call Home server HTTPS URL. This profile contains information such as the email address to reach the server, maximum message size, and message severity level for each alert group.



---

**Important** We recommend that you do not use the message severity level 0. If you use message severity level 0, all syslogs trigger Call Home messages, which can cause CPU and memory issues.

---

This section contains the following:

### Creating a New Destination Profile

#### Procedure

|        | Command or Action | Purpose                       |
|--------|-------------------|-------------------------------|
| Step 1 | enable            | Enables privileged EXEC mode. |

|               | Command or Action                                                                                                                                                                   | Purpose                                                                                                                                                                                                                                                                                                                               |
|---------------|-------------------------------------------------------------------------------------------------------------------------------------------------------------------------------------|---------------------------------------------------------------------------------------------------------------------------------------------------------------------------------------------------------------------------------------------------------------------------------------------------------------------------------------|
|               | <p><b>Example:</b></p> <pre>Router&gt; enable</pre>                                                                                                                                 | <ul style="list-style-type: none"> <li>• Enter your password, if prompted.</li> </ul>                                                                                                                                                                                                                                                 |
| <b>Step 2</b> | <p><b>configure terminal</b></p> <p><b>Example:</b></p> <pre>Router# configure terminal</pre>                                                                                       | Enters global configuration mode.                                                                                                                                                                                                                                                                                                     |
| <b>Step 3</b> | <p><b>call-home</b></p> <p><b>Example:</b></p> <pre>Router(config)# call-home</pre>                                                                                                 | Enters Call Home configuration mode.                                                                                                                                                                                                                                                                                                  |
| <b>Step 4</b> | <p><b>profile name</b></p> <p><b>Example:</b></p> <pre>Router(cfg-call-home)# profile profile1</pre>                                                                                | Enters the Call Home destination profile configuration mode for the specified destination profile. If the specified destination profile does not exist, it is created.                                                                                                                                                                |
| <b>Step 5</b> | <p><b>destination transport-method {email   http}</b></p> <p><b>Example:</b></p> <pre>Router(cfg-call-home-profile)# destination transport-method email</pre>                       | <p>(Optional) Enables the message transport method.</p> <ul style="list-style-type: none"> <li>• <b>email</b>—Sets the email message transport method.</li> <li>• <b>http</b>—Sets the HTTP message transport method.</li> </ul> <p><b>Note</b> The <b>no</b> option disables the method.</p>                                         |
| <b>Step 6</b> | <p><b>destination address {email email-address   http url}</b></p> <p><b>Example:</b></p> <pre>Router(cfg-call-home-profile)# destination address email myaddress@example.com</pre> | <p>Configures the destination email address or URL to which Call Home messages are sent.</p> <p><b>Note</b> When entering a destination URL, include either <b>http://</b> or <b>https://</b>, depending on whether the server is a secure server. If the destination is a secure server, you must also configure a trustpool CA.</p> |
| <b>Step 7</b> | <p><b>destination preferred-msg-format {long-text   short-text   xml}</b></p> <p><b>Example:</b></p> <pre>Router(cfg-call-home-profile)# destination preferred-msg-format xml</pre> | <p>(Optional) Configures a preferred message format. The default is XML.</p> <ul style="list-style-type: none"> <li>• <b>long-text</b>—Configures the long text message format.</li> <li>• <b>short-text</b>—Configures the short text message format.</li> <li>• <b>xml</b>—Configures the XML message format.</li> </ul>            |
| <b>Step 8</b> | <p><b>destination message-size bytes</b></p> <p><b>Example:</b></p> <pre>Router(cfg-call-home-profile)# destination message-size 3,145,728</pre>                                    | (Optional) Configures a maximum destination message size for the destination profile.                                                                                                                                                                                                                                                 |
| <b>Step 9</b> | <p><b>active</b></p> <p><b>Example:</b></p>                                                                                                                                         | Enables the destination profile. By default, the profile is enabled when it is created.                                                                                                                                                                                                                                               |

## Copying a Destination Profile

|                | Command or Action                                                                                                                                                | Purpose                                                                                                                                                                                                    |
|----------------|------------------------------------------------------------------------------------------------------------------------------------------------------------------|------------------------------------------------------------------------------------------------------------------------------------------------------------------------------------------------------------|
|                | Router(cfg-call-home-profile)# <b>active</b>                                                                                                                     | If you activate a profile which enables smart-licensing data while smart-licensing data is already being reported in another active profile, you will receive an error message.                            |
| <b>Step 10</b> | <b>reporting {all   smart-call-home-data   smart-licensing-data }</b><br><b>Example:</b><br>Router(cfg-call-home-profile)# <b>reporting smart-call-home-data</b> | Configures the type of data to report for a profile.<br>You can select either to report Smart Call Home data or Smart Licensing data. Selecting the <b>all</b> option reports data for both types of data. |
| <b>Step 11</b> | <b>end</b><br><b>Example:</b><br>Router(cfg-call-home-profile)# <b>end</b>                                                                                       | Returns to privileged EXEC mode.                                                                                                                                                                           |
| <b>Step 12</b> | <b>show call-home profile {name   all}</b><br><b>Example:</b><br>Router# <b>show call-home profile profile1</b>                                                  | Displays destination profile configuration for the specified profile or all configured profiles.                                                                                                           |
| <b>Step 13</b> | <b>show call-home smart-licensing</b><br><b>Example:</b><br>Router# <b>show call-home smart-licensing</b>                                                        | Displays the current Call Home Smart Licensing settings for the configured destination profiles.                                                                                                           |
| <b>Step 14</b> | <b>show call-home smart-licensing statistics</b><br><b>Example:</b><br>Router# <b>show call-home smart-licensing statistics</b>                                  | Displays the Call Home Smart Licensing statistics.                                                                                                                                                         |

## Copying a Destination Profile

You can create a new destination profile by copying an existing profile.

## Procedure

|               | Command or Action                                                                 | Purpose                                                                                                             |
|---------------|-----------------------------------------------------------------------------------|---------------------------------------------------------------------------------------------------------------------|
| <b>Step 1</b> | <b>enable</b><br><b>Example:</b><br>Router> <b>enable</b>                         | Enables privileged EXEC mode. <ul style="list-style-type: none"> <li>• Enter your password, if prompted.</li> </ul> |
| <b>Step 2</b> | <b>configure terminal</b><br><b>Example:</b><br>Router# <b>configure terminal</b> | Enters global configuration mode.                                                                                   |
| <b>Step 3</b> | <b>call-home</b><br><b>Example:</b><br>Router(config)# <b>call-home</b>           | Enters Call Home configuration mode.                                                                                |

|        | Command or Action                                                                                                                                        | Purpose                                                                                                                                                                                                                                                                                                              |
|--------|----------------------------------------------------------------------------------------------------------------------------------------------------------|----------------------------------------------------------------------------------------------------------------------------------------------------------------------------------------------------------------------------------------------------------------------------------------------------------------------|
| Step 4 | <p><b>copy profile</b> <i>source-profile target-profile</i></p> <p><b>Example:</b></p> <pre>Router(cfg-call-home) # copy profile profile1 profile2</pre> | <p>Creates a new destination profile with the same configuration settings as the existing destination profile.</p> <ul style="list-style-type: none"> <li>• <i>source-profile</i>—Name of the source destination profile.</li> <li>• <i>target-profile</i>—Name of the target or new destination profile.</li> </ul> |

### Renaming a Destination Profile

#### Procedure

|        | Command or Action                                                                                                                                            | Purpose                                                                                                                                                                                                                                     |
|--------|--------------------------------------------------------------------------------------------------------------------------------------------------------------|---------------------------------------------------------------------------------------------------------------------------------------------------------------------------------------------------------------------------------------------|
| Step 1 | <p><b>enable</b></p> <p><b>Example:</b></p> <pre>Router&gt; enable</pre>                                                                                     | <p>Enables privileged EXEC mode.</p> <ul style="list-style-type: none"> <li>• Enter your password, if prompted.</li> </ul>                                                                                                                  |
| Step 2 | <p><b>configure terminal</b></p> <p><b>Example:</b></p> <pre>Router# configure terminal</pre>                                                                | <p>Enters global configuration mode.</p>                                                                                                                                                                                                    |
| Step 3 | <p><b>call-home</b></p> <p><b>Example:</b></p> <pre>Router(config)# call-home</pre>                                                                          | <p>Enters Call Home configuration mode.</p>                                                                                                                                                                                                 |
| Step 4 | <p><b>rename profile</b> <i>source-profile target-profile</i></p> <p><b>Example:</b></p> <pre>Router(cfg-call-home) # rename profile profile1 profile2</pre> | <p>Renames the existing destination profile.</p> <ul style="list-style-type: none"> <li>• <i>source-profile</i>—Name of the source destination profile.</li> <li>• <i>target-profile</i>—Name of the target destination profile.</li> </ul> |

### Setting Profiles to Anonymous Mode

#### Procedure

|        | Command or Action                                                                             | Purpose                                                                                                                    |
|--------|-----------------------------------------------------------------------------------------------|----------------------------------------------------------------------------------------------------------------------------|
| Step 1 | <p><b>enable</b></p> <p><b>Example:</b></p> <pre>Router&gt; enable</pre>                      | <p>Enables privileged EXEC mode.</p> <ul style="list-style-type: none"> <li>• Enter your password, if prompted.</li> </ul> |
| Step 2 | <p><b>configure terminal</b></p> <p><b>Example:</b></p> <pre>Router# configure terminal</pre> | <p>Enters global configuration mode.</p>                                                                                   |

|               | Command or Action                                                                                                        | Purpose                                                                                                                                                                                                                                                   |
|---------------|--------------------------------------------------------------------------------------------------------------------------|-----------------------------------------------------------------------------------------------------------------------------------------------------------------------------------------------------------------------------------------------------------|
| <b>Step 3</b> | <b>call-home</b><br><b>Example:</b><br>Router(config) # <b>call-home</b>                                                 | Enters Call Home configuration mode.                                                                                                                                                                                                                      |
| <b>Step 4</b> | <b>profile name</b><br><b>Example:</b><br>Router(cfg-call-home) # <b>profile profile1</b>                                | Enters the Call Home destination profile configuration mode for the specified destination profile. If the specified destination profile does not exist, it is created.                                                                                    |
| <b>Step 5</b> | <b>anonymous-reporting-only</b><br><b>Example:</b><br>Router(cfg-call-home-profile) #<br><b>anonymous-reporting-only</b> | Sets the profile to anonymous mode.<br><b>Note</b> By default, the profile sends a full report of all types of events that are subscribed in the profile. When <b>anonymous-reporting-only</b> is set, only crash, inventory, and test messages are sent. |

## Subscribing to Alert Groups

An alert group is a predefined subset of Call Home alerts that are supported. A destination profile can receive one or more selected alert groups.

- Configuration
- Crash
- Diagnostic
- Environment
- Inventory
- Snapshot
- Syslog

The triggering events for each alert group are listed in the [Alert Groups Trigger Events and Commands](#), and the contents of the alert group messages are listed in the [Message Contents](#).



**Note** Call Home alerts are only sent to destination profiles that have subscribed to the alert group containing that Call Home alert. The alert group must be enabled. The Call Home event severity must be at or above the message severity set in the destination profile.

### Procedure

|               | Command or Action                                         | Purpose                                                                                                             |
|---------------|-----------------------------------------------------------|---------------------------------------------------------------------------------------------------------------------|
| <b>Step 1</b> | <b>enable</b><br><b>Example:</b><br>Router> <b>enable</b> | Enables privileged EXEC mode. <ul style="list-style-type: none"> <li>• Enter your password, if prompted.</li> </ul> |



|        | Command or Action                                                                                                                                                                                                                                                                           | Purpose                                                                                                                                                                |
|--------|---------------------------------------------------------------------------------------------------------------------------------------------------------------------------------------------------------------------------------------------------------------------------------------------|------------------------------------------------------------------------------------------------------------------------------------------------------------------------|
| Step 2 | <p><b>configure terminal</b></p> <p><b>Example:</b><br/>Router# <b>configure terminal</b></p>                                                                                                                                                                                               | Enters global configuration mode.                                                                                                                                      |
| Step 3 | <p><b>call-home</b></p> <p><b>Example:</b><br/>Router(config)# <b>call-home</b></p>                                                                                                                                                                                                         | Enters Call Home configuration mode.                                                                                                                                   |
| Step 4 | <p><b>alert-group {all   configuration   crash   diagnostic   environment   inventory   snapshot   syslog}</b></p> <p><b>Example:</b><br/>Router(cfg-call-home)# <b>alert-group all</b></p>                                                                                                 | Enables the specified alert group. Use the keyword <b>all</b> to enable all alert groups. By default, all alert groups are enabled.                                    |
| Step 5 | <p><b>profile name</b></p> <p><b>Example:</b><br/>Router(cfg-call-home)# <b>profile profile1</b></p>                                                                                                                                                                                        | Enters the Call Home destination profile configuration mode for the specified destination profile. If the specified destination profile does not exist, it is created. |
| Step 6 | <p><b>subscribe-to-alert-group configuration [periodic {daily hh:mm   monthly date hh:mm   weekly day hh:mm}]</b></p> <p><b>Example:</b><br/>Router(cfg-call-home-profile)#<br/><b>subscribe-to-alert-group configuration periodic daily 12:00</b></p>                                      | Subscribes this destination profile to the Configuration alert group. The Configuration alert group can be configured for periodic notification.                       |
| Step 7 | <p><b>subscribe-to-alert-group crash</b></p> <p><b>Example:</b><br/>Router(cfg-call-home-profile)#<br/><b>subscribe-to-alert-group crash</b></p>                                                                                                                                            | Subscribes to the Crash alert group in the user profile. By default, Cisco TAC profile subscribes to the Crash alert group and cannot be unsubscribed.                 |
| Step 8 | <p><b>subscribe-to-alert-group diagnostic [severity {catastrophic   disaster   fatal   critical   major   minor   warning   notification   normal   debugging}]</b></p> <p><b>Example:</b><br/>Router(cfg-call-home-profile)#<br/><b>subscribe-to-alert-group syslog severity major</b></p> | Subscribes this destination profile to the Diagnostic alert group. The Diagnostic alert group can be configured to filter messages based on severity.                  |
| Step 9 | <p><b>subscribe-to-alert-group environment [severity {catastrophic   disaster   fatal   critical   major   minor   warning   notification   normal   debugging}]</b></p> <p><b>Example:</b></p>                                                                                             | Subscribes this destination profile to the Environment alert group. The Environment alert group can be configured to filter messages based on severity.                |

|                | Command or Action                                                                                                                                                                                                                                                                                                                                                                               | Purpose                                                                                                                                                                                                                                                                                                                                                                                                                                                                                                                                                                                                                                                      |
|----------------|-------------------------------------------------------------------------------------------------------------------------------------------------------------------------------------------------------------------------------------------------------------------------------------------------------------------------------------------------------------------------------------------------|--------------------------------------------------------------------------------------------------------------------------------------------------------------------------------------------------------------------------------------------------------------------------------------------------------------------------------------------------------------------------------------------------------------------------------------------------------------------------------------------------------------------------------------------------------------------------------------------------------------------------------------------------------------|
|                | <pre>Router(cfg-call-home-profile)# subscribe-to-alert-group environment severity major</pre>                                                                                                                                                                                                                                                                                                   |                                                                                                                                                                                                                                                                                                                                                                                                                                                                                                                                                                                                                                                              |
| <b>Step 10</b> | <p><b>subscribe-to-alert-group inventory</b> [<b>periodic</b> {<b>daily</b> <i>hh:mm</i>   <b>monthly</b> <i>date hh:mm</i>   <b>weekly</b> <i>day hh:mm</i>}]</p> <p><b>Example:</b></p> <pre>Router(cfg-call-home-profile)# subscribe-to-alert-group inventory periodic daily 12:00</pre>                                                                                                     | Subscribes this destination profile to the Inventory alert group. The Inventory alert group can be configured for periodic notification.                                                                                                                                                                                                                                                                                                                                                                                                                                                                                                                     |
| <b>Step 11</b> | <p><b>subscribe-to-alert-group snapshot</b> [<b>periodic</b> {<b>daily</b> <i>hh:mm</i>   <b>monthly</b> <i>date hh:mm</i>   <b>weekly</b> <i>day hh:mm</i>   <b>hourly</b> <i>mm</i>   <b>interval</b> <i>mm</i>}]</p> <p><b>Example:</b></p> <pre>Router(cfg-call-home-profile)# subscribe-to-alert-group snapshot periodic daily 12:00</pre>                                                 | <p>Subscribes this destination profile to the Snapshot alert group. The Snapshot alert group can be configured for periodic notification.</p> <p>By default, the Snapshot alert group has no command to run. You can add commands into the alert group. The output of commands that are added in the Snapshot alert group are included in the snapshot message.</p>                                                                                                                                                                                                                                                                                          |
| <b>Step 12</b> | <p><b>subscribe-to-alert-group syslog</b> [<b>severity</b> {<b>catastrophic</b>   <b>disaster</b>   <b>fatal</b>   <b>critical</b>   <b>major</b>   <b>minor</b>   <b>warning</b>   <b>notification</b>   <b>normal</b>   <b>debugging</b>}] [<b>pattern</b> <i>string</i>]</p> <p><b>Example:</b></p> <pre>Router(cfg-call-home-profile)# subscribe-to-alert-group syslog severity major</pre> | <p>Subscribes this destination profile to the Syslog alert group. The Syslog alert group can be configured to filter messages based on the severity. You can specify a pattern to be matched in the syslog message. If the pattern contains spaces, you must enclose it in quotes (").</p> <p>You can specify a text pattern to be matched within each syslog message. If you configure a pattern, a Syslog alert group message is sent only if it contains the specified pattern and meets the severity threshold. If the pattern contains spaces, you must enclose it in quotes ("). You can specify up to five patterns for each destination profile.</p> |
| <b>Step 13</b> | <p><b>subscribe-to-alert-group all</b></p> <p><b>Example:</b></p> <pre>Router(cfg-call-home-profile)# subscribe-to-alert-group all</pre>                                                                                                                                                                                                                                                        | <p>(Optional) Subscribes to all available alert groups.</p> <p><b>Important</b> Entering this command generates many syslog messages. We recommend that you subscribe to alert groups individually, using appropriate severity levels and patterns when possible.</p>                                                                                                                                                                                                                                                                                                                                                                                        |

## Periodic Notification

For destination profile subscriptions to either the Configuration, Inventory, or Snapshot alert group, you can choose to receive the alert group messages asynchronously or periodically. The following time intervals are available:

- Daily—Specify the time of day to send, using an hour:minute format *hh:mm*, with a 24-hour clock (for example, 14:30).
- Weekly—Specify the day of the week and time of day in the format *day hh:mm*. The day of the week is spelled out (for example, Monday).

- Monthly—Specify the numeric date, from 1 to 31, and the time of day, in the format date *hh:mm*.
- Interval—Specifies the interval at which the periodic message is sent, from 1 to 60 minutes.
- Hourly—Specifies the minute of the hour at which the periodic message is sent, from 0 to 59 minutes.



**Note** Hourly and by interval periodic notifications are available for the Snapshot alert group only.

### Message Severity Threshold

Call Home allows you to filter messages based on the severity. You can associate each predefined or user-defined destination profile with a Call Home threshold from 0 (least urgent) to 9 (most urgent). The default is 0 (all messages are sent).

When subscribing a destination profile to the Environment or Syslog alert group, set a threshold for relay of alert group messages. The threshold can be based on the message severity level. Messages with a value lower than the destination profile threshold is not sent to the destination.

Subscribing to an alert group in a destination profile with a specified severity also includes messages. Events that have same or higher severity in that alert group trigger these messages.



**Note** Subscribing to syslog message with a low severity level is not recommended. This subscription would trigger too many syslog messages that would lower the system performance.



**Note** Call Home severity levels and severity levels of the system message logging are different.

*Table 330: Severity and Syslog Level Mapping*

| Smart Call Home Level | Keyword             | Syslog Level  | Description                                                           |
|-----------------------|---------------------|---------------|-----------------------------------------------------------------------|
| 9                     | <b>catastrophic</b> | —             | Network-wide catastrophic failure.                                    |
| 8                     | <b>disaster</b>     | —             | Significant network impact.                                           |
| 7                     | <b>fatal</b>        | Emergency (0) | System is unusable.                                                   |
| 6                     | <b>critical</b>     | Alert (1)     | Critical conditions that indicate that immediate attention is needed. |
| 5                     | <b>major</b>        | Critical (2)  | Major conditions.                                                     |
| 4                     | <b>minor</b>        | Error (3)     | Minor conditions.                                                     |
| 3                     | <b>warning</b>      | Warning (4)   | Warning conditions.                                                   |

| Smart Call Home Level | Keyword             | Syslog Level    | Description                                                                          |
|-----------------------|---------------------|-----------------|--------------------------------------------------------------------------------------|
| 2                     | <b>notification</b> | Notice (5)      | Basic notification and informational messages. Possibly independently insignificant. |
| 1                     | <b>normal</b>       | Information (6) | Normal event signifying return to normal state.                                      |
| 0                     | <b>debugging</b>    | Debug (7)       | Debugging messages.                                                                  |

### Syslog Pattern Matching

When you subscribe a destination profile to the Syslog alert group, you can optionally specify a text pattern to be matched within each syslog message. If you configure a pattern, a Syslog alert group message is sent only if it contains the specified pattern and meets the severity threshold. If the pattern contains spaces, you must enclose it in quotes (") when configuring. You can specify up to five patterns for each destination profile.

### Configuring Snapshot Command List

To configure the snapshot command list, perform the following steps:

#### Procedure

|               | Command or Action                                                                                                                                | Purpose                                                                                                                                                                                                                                    |
|---------------|--------------------------------------------------------------------------------------------------------------------------------------------------|--------------------------------------------------------------------------------------------------------------------------------------------------------------------------------------------------------------------------------------------|
| <b>Step 1</b> | <b>configure terminal</b><br><b>Example:</b><br>Device# <b>configure terminal</b>                                                                | Enters global configuration mode.                                                                                                                                                                                                          |
| <b>Step 2</b> | <b>call-home</b><br><b>Example:</b><br>Device(config)# <b>call-home</b>                                                                          | Enters Call Home configuration mode.                                                                                                                                                                                                       |
| <b>Step 3</b> | <b>[no   default ] alert-group-config snapshot</b><br><b>Example:</b><br>Device(cfg-call-home)# <b>alert-group-config snapshot</b>               | Enters snapshot configuration mode.<br>The <b>no</b> or <b>default</b> command removes the snapshot command.                                                                                                                               |
| <b>Step 4</b> | <b>[no   default ] add-command <i>command string</i></b><br><b>Example:</b><br>Device(cfg-call-home-snapshot)# <b>add-command "show version"</b> | Adds the command to the Snapshot alert group. The <b>no</b> or <b>default</b> command removes the corresponding command. <ul style="list-style-type: none"> <li><i>command string</i>—Cisco IOS command. Maximum length is 128.</li> </ul> |

|        | Command or Action                                                                                | Purpose                            |
|--------|--------------------------------------------------------------------------------------------------|------------------------------------|
| Step 5 | <p><b>end</b></p> <p><b>Example:</b></p> <pre>Device(cfg-call-home-snapshot) # <b>exit</b></pre> | Exits and saves the configuration. |

## Configuring General Email Options

### Configuring the Mail Server

To use the email message transport, you must configure at least one Simple Mail Transfer Protocol (SMTP) email server address. You can specify up to four backup email servers, for a maximum of five total mail-server definitions.

Consider the following guidelines when configuring the mail server:

- Backup email servers can be defined by repeating the **mail-server** command using different priority numbers.
- The **mail-server priority number** parameter can be configured from 1 to 100. The server with the highest priority (lowest priority number) is tried first.

To configure general email options, perform the following steps:

### SUMMARY STEPS

1. **configure terminal**
2. **call-home**
3. **mail-server** {*ipv4-address* | *name*} **priority number**
4. **sender from** *email-address*
5. **sender reply-to** *email-address*
6. **source-interface** *interface-name*
7. **source-ip-address** *ipv4/ipv6 address*
8. **vrfvrf-name**

### DETAILED STEPS

|        | Command or Action                                                                                    | Purpose                              |
|--------|------------------------------------------------------------------------------------------------------|--------------------------------------|
| Step 1 | <p><b>configure terminal</b></p> <p><b>Example:</b></p> <pre>Device# <b>configure terminal</b></pre> | Enters global configuration mode.    |
| Step 2 | <p><b>call-home</b></p> <p><b>Example:</b></p> <pre>Device(config)# <b>call-home</b></pre>           | Enters call home configuration mode. |

|               | Command or Action                                                                                                                                                              | Purpose                                                                                                                                                                                                                                                                                                                                                                                                              |
|---------------|--------------------------------------------------------------------------------------------------------------------------------------------------------------------------------|----------------------------------------------------------------------------------------------------------------------------------------------------------------------------------------------------------------------------------------------------------------------------------------------------------------------------------------------------------------------------------------------------------------------|
| <b>Step 3</b> | <p><b>mail-server</b> <i>{ipv4-address   name}</i> <b>priority number</b></p> <p><b>Example:</b></p> <pre>Device(cfg-call-home)# mail-server stmp.example.com priority 1</pre> | <p>Assigns an email server address and its relative priority among configured email servers.</p> <p>Provide either of the following:</p> <ul style="list-style-type: none"> <li>• The email server's IP address or</li> <li>• The email server's fully qualified domain name (FQDN) of 64 characters or less.</li> </ul> <p>Assign a priority number between 1 (highest priority) and 100 (lowest priority).</p>     |
| <b>Step 4</b> | <p><b>sender from</b> <i>email-address</i></p> <p><b>Example:</b></p> <pre>Device(cfg-call-home)# sender from username@example.com</pre>                                       | <p>(Optional) Assigns the email address that appears in the from field in Call Home email messages. If no address is specified, the contact email address is used.</p>                                                                                                                                                                                                                                               |
| <b>Step 5</b> | <p><b>sender reply-to</b> <i>email-address</i></p> <p><b>Example:</b></p> <pre>Device(cfg-call-home)# sender reply-to username@example.com</pre>                               | <p>(Optional) Assigns the email address that appears in the reply-to field in Call Home email messages.</p>                                                                                                                                                                                                                                                                                                          |
| <b>Step 6</b> | <p><b>source-interface</b> <i>interface-name</i></p> <p><b>Example:</b></p> <pre>Device(cfg-call-home)# source-interface loopback1</pre>                                       | <p>Assigns the source interface name to send call-home messages.</p> <p><i>interface-name</i>—Source interface name. Maximum length is 64.</p> <p><b>Note</b> For HTTP messages, use the <b>ip http client source-interface interface-name</b> command in global configuration mode to configure the source interface name. This command allows all HTTP clients on the device to use the same source interface.</p> |
| <b>Step 7</b> | <p><b>source-ip-address</b> <i>ipv4/ipv6 address</i></p> <p><b>Example:</b></p> <pre>Device(cfg-call-home)# ip-address 209.165.200.226</pre>                                   | <p>Assigns source IP address to send call-home messages.</p> <ul style="list-style-type: none"> <li>• <i>ipv4/ipv6 address</i>—Source IP (IPv4 or IPv6) address. Maximum length is 64.</li> </ul>                                                                                                                                                                                                                    |
| <b>Step 8</b> | <p><b>vrf</b> <i>vrf-name</i></p> <p><b>Example:</b></p> <pre>Device(cfg-call-home)# vrf vpn1</pre>                                                                            | <p>(Optional) Specifies the VRF instance to send call-home email messages. If no vrf is specified, the global routing table is used.</p>                                                                                                                                                                                                                                                                             |

|  | Command or Action | Purpose                                                                                                                                                                                                                                                                                         |
|--|-------------------|-------------------------------------------------------------------------------------------------------------------------------------------------------------------------------------------------------------------------------------------------------------------------------------------------|
|  |                   | <p><b>Note</b> For HTTP messages, if the source interface is associated with a VRF, use the <b>ip http client source-interface <i>interface-name</i></b> command in global configuration mode. This command would specify the VRF instance that is used for all HTTP clients on the device.</p> |

### Specifying Rate Limit for Sending Call Home Messages

To specify the rate limit for sending Call Home messages, perform the following steps:

#### SUMMARY STEPS

1. **configure terminal**
2. **call-home**
3. **rate-limit *number***

#### DETAILED STEPS

|                      | Command or Action                                                                                                 | Purpose                                                                                                                                                                          |
|----------------------|-------------------------------------------------------------------------------------------------------------------|----------------------------------------------------------------------------------------------------------------------------------------------------------------------------------|
| <p><b>Step 1</b></p> | <p><b>configure terminal</b></p> <p><b>Example:</b></p> <p>Device# <b>configure terminal</b></p>                  | <p>Enters global configuration mode.</p>                                                                                                                                         |
| <p><b>Step 2</b></p> | <p><b>call-home</b></p> <p><b>Example:</b></p> <p>Device(config)# <b>call-home</b></p>                            | <p>Enters call home configuration mode.</p>                                                                                                                                      |
| <p><b>Step 3</b></p> | <p><b>rate-limit <i>number</i></b></p> <p><b>Example:</b></p> <p>Device(cfg-call-home) # <b>rate-limit 40</b></p> | <p>Specifies a limit on the number of messages that are sent per minute.</p> <ul style="list-style-type: none"> <li>• <i>number</i>—Range 1 to 60. The default is 20.</li> </ul> |

### Specifying HTTP Proxy Server

To specify an HTTP proxy server for sending Call Home HTTP(S) messages to a destination, perform the following steps:

#### SUMMARY STEPS

1. **configure terminal**
2. **call-home**
3. **http-proxy {*ipv4-address* | *ipv6-address name*} *name***

**DETAILED STEPS**

|               | Command or Action                                                                                                                 | Purpose                                          |
|---------------|-----------------------------------------------------------------------------------------------------------------------------------|--------------------------------------------------|
| <b>Step 1</b> | <b>configure terminal</b><br><b>Example:</b><br>Device# <b>configure terminal</b>                                                 | Enters global configuration mode.                |
| <b>Step 2</b> | <b>call-home</b><br><b>Example:</b><br>Device(config)# <b>call-home</b>                                                           | Enters call home configuration mode.             |
| <b>Step 3</b> | <b>http-proxy {ipv4-address   ipv6-address name} name</b><br><b>Example:</b><br>Device(config)# <b>http-proxy 10.1.1.1 port 1</b> | Specifies the proxy server for the HTTP request. |

**Enabling AAA Authorization to Run Cisco IOS Commands for Call Home Messages**

To enable AAA authorization to run Cisco IOS commands that enable the collection of output for a Call Home message, perform the following steps:

**SUMMARY STEPS**

1. **configure terminal**
2. **call-home**
3. **aaa-authorization**
4. **aaa-authorization [username username]**

**DETAILED STEPS**

|               | Command or Action                                                                              | Purpose                                                                                            |
|---------------|------------------------------------------------------------------------------------------------|----------------------------------------------------------------------------------------------------|
| <b>Step 1</b> | <b>configure terminal</b><br><b>Example:</b><br>Device# <b>configure terminal</b>              | Enters global configuration mode.                                                                  |
| <b>Step 2</b> | <b>call-home</b><br><b>Example:</b><br>Device(config)# <b>call-home</b>                        | Enters call home configuration mode.                                                               |
| <b>Step 3</b> | <b>aaa-authorization</b><br><b>Example:</b><br>Device(cfg-call-home)# <b>aaa-authorization</b> | Enables AAA authorization.<br><b>Note</b> By default, AAA authorization is disabled for Call Home. |



|        | Command or Action                                                                                                                                               | Purpose                                                                                                                                                                       |
|--------|-----------------------------------------------------------------------------------------------------------------------------------------------------------------|-------------------------------------------------------------------------------------------------------------------------------------------------------------------------------|
| Step 4 | <b>aaa-authorization</b> [ <i>username username</i> ]<br><b>Example:</b><br>Device(cfg-call-home) # <b>aaa-authorization</b><br><b>username</b> <i>username</i> | Specifies the username for authorization. <ul style="list-style-type: none"> <li>• <b>username</b> <i>user</i>—Default username is callhome. Maximum length is 64.</li> </ul> |

### Configuring Syslog Throttling

To enable or disable Call Home syslog message throttling and avoid sending repetitive Call Home syslog messages, perform the following steps:

#### SUMMARY STEPS

1. **configure terminal**
2. **call-home**
3. **[no] syslog-throttling**

#### DETAILED STEPS

|        | Command or Action                                                                                    | Purpose                                                                                                                                                            |
|--------|------------------------------------------------------------------------------------------------------|--------------------------------------------------------------------------------------------------------------------------------------------------------------------|
| Step 1 | <b>configure terminal</b><br><b>Example:</b><br>Device# <b>configure terminal</b>                    | Enters global configuration mode.                                                                                                                                  |
| Step 2 | <b>call-home</b><br><b>Example:</b><br>Device(config)# <b>call-home</b>                              | Enters call home configuration mode.                                                                                                                               |
| Step 3 | <b>[no] syslog-throttling</b><br><b>Example:</b><br>Device(cfg-call-home) # <b>syslog-throttling</b> | Enables or disables Call Home syslog message throttling and avoids sending repetitive Call Home syslog messages. By default, syslog message throttling is enabled. |

### Configuring Call Home Data Privacy

The **data-privacy** command scrubs data, such as passwords and IP addresses, from running configuration files to protect the privacy of customers. Enabling the **data-privacy** command can affect CPU utilization when scrubbing a large amount of data. Currently, **show** command output is not being scrubbed except for configuration messages in the **show running-config** all and show startup-config data.

#### SUMMARY STEPS

1. **configure terminal**
2. **call-home**
3. **data-privacy {level {normal | high} | hostname}**

## DETAILED STEPS

|               | Command or Action                                                                                                                  | Purpose                                                                                                                                                                                                                                                                                                                                                                                                                                                                                                                                                                                                                                                                                  |
|---------------|------------------------------------------------------------------------------------------------------------------------------------|------------------------------------------------------------------------------------------------------------------------------------------------------------------------------------------------------------------------------------------------------------------------------------------------------------------------------------------------------------------------------------------------------------------------------------------------------------------------------------------------------------------------------------------------------------------------------------------------------------------------------------------------------------------------------------------|
| <b>Step 1</b> | <b>configure terminal</b><br><b>Example:</b><br>Device# <b>configure terminal</b>                                                  | Enters global configuration mode.                                                                                                                                                                                                                                                                                                                                                                                                                                                                                                                                                                                                                                                        |
| <b>Step 2</b> | <b>call-home</b><br><b>Example:</b><br>Device(config)# <b>call-home</b>                                                            | Enters call home configuration mode.                                                                                                                                                                                                                                                                                                                                                                                                                                                                                                                                                                                                                                                     |
| <b>Step 3</b> | <b>data-privacy {level {normal   high}   hostname}</b><br><b>Example:</b><br>Device(cfg-call-home)# <b>data-privacy level high</b> | Scrubs data from running configuration file to protect the privacy of the user. The default data-privacy level is normal.<br><br><b>Note</b> Enabling the data-privacy command can affect CPU utilization when scrubbing a large amount of data. <ul style="list-style-type: none"> <li>• <b>normal</b>—Scrubs sensitive data such as passwords.</li> <li>• <b>high</b>—Scrubs all normal-level commands plus the IP domain name and IP address commands.</li> <li>• <b>hostname</b>—Scrubs all high-level commands plus the hostname command.</li> </ul> <b>Note</b> Scrubbing the hostname from configuration messages can cause Smart Call Home processing failure on some platforms. |

## Sending Call Home Messages Manually

## Sending a Call Home Test Message Manually

You can use the **call-home test** command to send a user-defined Call Home test message.

## SUMMARY STEPS

1. **call-home test** [*“test-message”*] **profile name**

## DETAILED STEPS

|               | Command or Action                                                                                                                        | Purpose                                                                                                                                                                                                                                     |
|---------------|------------------------------------------------------------------------------------------------------------------------------------------|---------------------------------------------------------------------------------------------------------------------------------------------------------------------------------------------------------------------------------------------|
| <b>Step 1</b> | <b>call-home test</b> [ <i>“test-message”</i> ] <b>profile name</b><br><b>Example:</b><br>Router# <b>call-home test profile profile1</b> | Sends a test message to the specified destination profile. The user-defined test message text is optional, but must be enclosed in quotes (“ ”) if it contains spaces. If no user-defined message is configured, a default message is sent. |

## Sending Call Home Alert Group Messages Manually

### Before you begin

- Only the snapshot, crash, configuration, and inventory alert groups can be sent manually. Syslog alert groups cannot be sent manually.
- When you manually trigger a snapshot, configuration, or inventory alert group message and you specify a destination profile name, a message is sent to the destination profile regardless of the profile's active status, subscription status, or severity setting.
- When you manually trigger a snapshot, configuration, or inventory alert group message and do not specify a destination profile name, a message is sent to all active profiles that have either a normal or periodic subscription to the specified alert group.

### Procedure

|        | Command or Action                                                                                                                                                    | Purpose                                                                                                                       |
|--------|----------------------------------------------------------------------------------------------------------------------------------------------------------------------|-------------------------------------------------------------------------------------------------------------------------------|
| Step 1 | <b>enable</b><br><b>Example:</b><br>Router# <code>enable</code>                                                                                                      | Enables privileged EXEC mode.<br><br>• Enter your password, if prompted.                                                      |
| Step 2 | <b>call-home send alert-group snapshot</b> [profile name ]<br><b>Example:</b><br>Router# <code>call-home send alert-group snapshot profile profile1</code>           | Sends a snapshot alert group message to one destination profile if specified, or to all subscribed destination profiles.      |
| Step 3 | <b>call-home send alert-group crash</b> [profile name ]<br><b>Example:</b><br>Router# <code>call-home send alert-group configuration profile profile1</code>         | Sends a crash alert group message to one destination profile if specified, or to all subscribed destination profiles.         |
| Step 4 | <b>call-home send alert-group configuration</b> [profile name ]<br><b>Example:</b><br>Router# <code>call-home send alert-group configuration profile profile1</code> | Sends a configuration alert group message to one destination profile if specified, or to all subscribed destination profiles. |
| Step 5 | <b>call-home send alert-group inventory</b> [profile name ]<br><b>Example:</b><br>Router# <code>call-home send alert-group inventory</code>                          | Sends an inventory alert group message to one destination profile if specified, or to all subscribed destination profiles.    |

### Submitting Call Home Analysis and Report Requests

The **call-home request** command allows you to submit the system information to Cisco Systems. The report provides helpful analysis and information specific to your system. You can request various reports, including security alerts, known bugs, recommendations, and the command references.

Note the following guidelines when manually sending Call Home analysis and report requests:

- If a **profile** *name* is specified, the request is sent to the profile. If no profile is specified, the request is sent to the Cisco TAC profile. The Call-home request can have a recipient profile that is not enabled. The recipient profile specifies the email address where the transport gateway is configured. The recipient profile allows the request message to be forwarded to the Cisco TAC and you can receive the reply from the Smart Call Home service.
- The **ccoid** *user-id* is the registered identifier of the Smart Call Home user. If the *user-id* is specified, the response is sent to the email address of the registered user. If no *user-id* is specified, the response is sent to the contact email address of the device.
- Based on the keyword specifying the type of report that is requested, the following information is returned:
  - **config-sanity**—Information on the recommendations for the current running configuration.
  - **bugs-list**—Known bugs in the running version and in the currently applied features.
  - **command-reference**—Reference links to all commands in the running configuration.
  - **product-advisory**—Product Security Incident Response Team (PSIRT) notices. The PSIRT includes End of Life (EOL) or End of Sales (EOS) notices, or field notices (FN) that may affect devices in your network.

To submit a request for analysis and report information from the Cisco Output Interpreter tool, complete the following steps:

## SUMMARY STEPS

1. **call-home request output-analysis** “*show-command*”
2. **call-home request** {**config-sanity** | **bugs-list** | **command-reference** | **product-advisory**}

## DETAILED STEPS

|        | Command or Action                                                                                                                                                                                                                                                      | Purpose                                                                                                                                                                                                                                                                                                                                                                             |
|--------|------------------------------------------------------------------------------------------------------------------------------------------------------------------------------------------------------------------------------------------------------------------------|-------------------------------------------------------------------------------------------------------------------------------------------------------------------------------------------------------------------------------------------------------------------------------------------------------------------------------------------------------------------------------------|
| Step 1 | <b>call-home request output-analysis</b> “ <i>show-command</i> ”<br><b>Example:</b><br>[ <b>profile</b> <i>name</i> ] [ <b>ccoid</b> <i>user-id</i> ]<br><b>Example:</b><br>Device# <b>call-home request output-analysis</b><br>“ <b>show diag</b> ” <b>profile</b> TG | Sends the output of the specified <b>show</b> command for analysis. The <b>show</b> command must be contained in quotes (“”).                                                                                                                                                                                                                                                       |
| Step 2 | <b>call-home request</b> { <b>config-sanity</b>   <b>bugs-list</b>   <b>command-reference</b>   <b>product-advisory</b> }<br><b>Example:</b><br>[ <b>profile</b> <i>name</i> ] [ <b>ccoid</b> <i>user-id</i> ]<br><b>Example:</b>                                      | Sends the output of a predetermined set of commands, such as the <b>show running-config all</b> and <b>show version</b> commands, for analysis. In addition, the <b>call home request product-advisory</b> subcommand includes all inventory alert group commands. The keyword that is specified after the <b>call-home request</b> command specifies the type of report requested. |

|  | Command or Action                                         | Purpose |
|--|-----------------------------------------------------------|---------|
|  | Device# <b>call-home request config-sanity profile TG</b> |         |

### Manually Sending Command Output Message for One Command or a Command List

The **call-home send** command runs a CLI command and emails the command output to Cisco, or to an email address that is specified.

Note the following guidelines when sending the output of a command:

- The specified Cisco IOS command or list of Cisco IOS commands can be any run command, including commands for all modules. The command must be contained in quotes (").
- If the email option is selected using the “email” keyword and an email address is specified, the command output is sent to that address. If email or HTTP option is not specified, the output is sent in long-text format to the Cisco TAC (attach@cisco.com). The output has information on the specified service request number.
- Ensure that a service request number is provided if no “email” nor the “http” keyword is specified. The service request number is required for both long-text and XML message formats and is provided in the subject line of the email.
- If the HTTP option is specified without a profile name or destination URL, the CiscoTac-1 profile destination HTTP or HTTPS URL is used as the destination. The destination email address can be specified so that Smart Call Home can forward the message to the email address. You can specify the destination email address and the SR number, or you can specify either of them.
- If a profile is specified and the profile has callhome@cisco.com as one of its email destinations, you must use XML as the message format. If you use long-text format, an error message is displayed.

To execute a command and send the command output, complete the following step:

#### Procedure

|               | Command or Action                                                                                                                                                                                                                                                                                                                                                                                                                                                                                                                                             | Purpose                                                                                                                                                                                                                                                                                                                                                                                                                                                                                                                                                                                                                                                                                                                                                                  |
|---------------|---------------------------------------------------------------------------------------------------------------------------------------------------------------------------------------------------------------------------------------------------------------------------------------------------------------------------------------------------------------------------------------------------------------------------------------------------------------------------------------------------------------------------------------------------------------|--------------------------------------------------------------------------------------------------------------------------------------------------------------------------------------------------------------------------------------------------------------------------------------------------------------------------------------------------------------------------------------------------------------------------------------------------------------------------------------------------------------------------------------------------------------------------------------------------------------------------------------------------------------------------------------------------------------------------------------------------------------------------|
| <b>Step 1</b> | <p>Use one of the following commands:</p> <ul style="list-style-type: none"> <li>• <b>call-home send</b> {cli command   cli list} [email [profile profile-name   email] [msg-format {long-text   xml}]] [tac-sevice-request SR#]</li> <li>• <b>call-home send</b> {cli command   cli list} [http [profile profile-name   URL-dest] [destination-email-address email]] [tac-sevice-request SR#]</li> </ul> <p><b>Example:</b></p> <pre>Router# call-home send "show version;show running-config show inventory" email support@example.com msg-format xml</pre> | <p>Executes the CLI or CLI list and sends output via email or HTTP.</p> <ul style="list-style-type: none"> <li>• {cli command   cli list}—Specifies the Cisco IOS command or list of Cisco IOS commands (separated by ‘;’). It can be any run command, including commands for all modules. The commands must be contained in quotes (").</li> <li>• <b>email</b> [profile profile-name   email] [msg-format {long-text   xml}]</li> </ul> <p>If the email option is chosen and a profile name is specified, the command output is sent to the email address configured in the profile. If an email address is specified, the command output is sent to the specified email address. The message is in long-text or XML format with the service request number in the</p> |

|  | Command or Action | Purpose                                                                                                                                                                                                                                                                                                                                                                                                                                                                                                                                                                                                                                                                                                                                                                                                                                                                                                                                                                                                                                                                                                                                                                                                                                                                                                                                                                                                 |
|--|-------------------|---------------------------------------------------------------------------------------------------------------------------------------------------------------------------------------------------------------------------------------------------------------------------------------------------------------------------------------------------------------------------------------------------------------------------------------------------------------------------------------------------------------------------------------------------------------------------------------------------------------------------------------------------------------------------------------------------------------------------------------------------------------------------------------------------------------------------------------------------------------------------------------------------------------------------------------------------------------------------------------------------------------------------------------------------------------------------------------------------------------------------------------------------------------------------------------------------------------------------------------------------------------------------------------------------------------------------------------------------------------------------------------------------------|
|  |                   | <p>subject. The profile name or email address, the service request number, or both must be specified. The service request number is required if the profile name or email address is not specified. The default is <code>attach@cisco.com</code> for long-text format and <code>callhome@cisco.com</code> for XML format.</p> <ul style="list-style-type: none"> <li>• <b>http</b> [<b>profile</b> <i>profile-name</i>   <i>URL-dest</i>] [<b>destination-email-address</b> <i>email</i>]</li> </ul> <p>You can choose the HTTP option without a profile name or destination URL. The command output is in XML format and is sent to the Smart Call Home backend server (URL specified in the TAC profile). If a profile name or destination URL is specified, the command output is sent to the destination URLs. The destination URLs can be configured in the profile (profile-name case), or the destination URL can be specified in the command.</p> <p><b>destination-email-address</b> <i>email</i> can be specified so that the backend server can forward the message to the email address. The email address, the service request number, or both must be specified.</p> <ul style="list-style-type: none"> <li>• <b>tac-service-request</b> <i>SR#</i></li> </ul> <p>Specifies the service request number. The service request number is required if the email address is not specified.</p> |

## Configuring Diagnostic Signatures

The Diagnostic Signatures feature downloads digitally signed signatures to devices. Diagnostic Signatures (DS) files are formatted files that collate knowledge of diagnostic events. DS files provide methods to troubleshoot them without a need to upgrade the Cisco software. The aim of DS is to deliver flexible intelligence that can detect and collect troubleshooting information. This information can be used to resolve known problems in customer networks.

### Prerequisites for Diagnostic Signatures

Before you download and configure diagnostic signatures (DSs) on a device, you must ensure that the following conditions are met:

- Ensure that you assign a diagnostic signature to the device. Refer to the “Diagnostic Signature Downloading” section for more information about how to assign DSs to devices.
- HTTP/Secure HTTP (HTTPS) transport is required for downloading DS files. Install the certification authority (CA) certificate to enable the authentication of the destination HTTPS server.



---

**Note** If you configure the trustpool feature, the CA certificate is not required.

---

## Information About Diagnostic Signatures

### Diagnostic Signature Overview

Diagnostic signatures (DS) for the Call Home system provides a flexible framework that allows the defining of new events and corresponding CLIs. DSs can analyze these events without upgrading the Cisco software.

DSs enable you to define more types of events and trigger types than the standard Call Home feature supports. The DS subsystem downloads and processes files on a device and also handles callbacks for diagnostic signature events.

The Diagnostic Signature feature downloads digitally signed signatures that are in the form of files to devices. DS files are formatted files that collate the knowledge of diagnostic events and provide methods to troubleshoot these events.

DS files contain XML data to specify the event description, and these files include CLI commands or scripts to perform required actions. Cisco or a third party digitally signs the DSs. The signing ensures their integrity, reliability, and security.

The structure of a DS file can be one of the following formats.

- Metadata-based simple signature. This format specifies the event type. The format also has information to match the event and perform actions such as collecting information by using the CLI. The signature can also change configurations on the device as a workaround for certain bugs.
- Embedded Event Manager (EEM) Tool Command Language (Tcl) script-based signature. This format specifies new events in the event register line and more action in the Tcl script.
- Combination of both the preceding formats.

The following basic information is contained in a DS file:

- ID (unique number)—unique key that represents a DS file that can be used to search a DS.
- Name (ShortDescription)—unique description of the DS file that can be used in lists for selection.
- Description—long description about the signature.
- Revision—version number, which increments when the DS content is updated.
- Event & Action—defines the event to be detected and the action to be performed after the event happens.

### Diagnostic Signature Downloading

To download the diagnostic signature (DS) file, you require the secure HTTP (HTTPS) protocol. If you have configured an email transport method to download files on your device, change your assigned profile transport method to HTTPS.

Cisco software uses a PKI Trustpool Management feature, and this feature is enabled by default. The trustpool feature creates a scheme to provision, store, and manage a pool of certificates from known certification

authorities (CAs) on devices. The trustpool feature also installs the CA certificate automatically. The CA certificate is required for the authentication of the destination HTTPS servers.

There are two types of DS update requests to download DS files: regular and forced-download.

Regular download requests DS files that were recently updated. You can trigger a regular download request either by using a periodic configuration or by initiating an on-demand CLI. The regular download update happens only when the version of the requested DS is different from the version of the DS on the device. Periodic download is only started after there is any DS assigned to the device from DS web portal. After the assignment, responses to the periodic inventory message from the same device will include a field. The field notifies the device to start its periodic DS download or an update. In a DS update request message, the status and revision number of the DS is included. However, only a DS with the latest revision number is downloaded.

Forced-download downloads a specific DS or a set of DSs. You can trigger the forced-download update request only by initiating an on-demand CLI. In a force-download update request, the latest version of the DS file is downloaded irrespective of the current DS file version on the device.

The DS file is digitally signed, and signature verification is performed on every downloaded DS file to make sure it is from a trusted source.

## Diagnostic Signature Signing

The diagnostic signature (DS) files are digitally signed before they are made available for downloading. The following methods are used for digitally signing DS files:

- Signing algorithm (Rivest Shamir and Adleman [RSA] 2048 bits).
- Request key pairs to the Abraxas system, which is the digital signing client.
- DS signed through the secure socket layer (SSL) through a code signing client, where the signature is embedded using XML tags.
- Public keys that are embedded in the DS subsystem (Cisco-signed, partner-signed, third-party signed) in the Cisco software. The digitally signed DS file contains the product name such as Diagnostic\_Signatures (Cisco signed), Diagnostic\_Signatures\_Partner, Diagnostic\_Signatures\_3rd\_Party. The product names are only used to sign the DS files.

The digital signing client can be found at the <https://abraxas.cisco.com/SignEngine/submit.jsp> link.

These conditions that must be met to verify the digital signature in a DS file:

- Code sign component support must be available in Cisco software.
- Various public keys that verify the different kinds of diagnostic signatures must be included in platforms where DS is supported.
- After parsing and retrieving the DS, the DS must execute the verification application program interface (API) to verify that the DS is valid.

## Diagnostic Signature Workflow

The diagnostic signature feature is enabled by default in Cisco software. The following is the workflow for creating diagnostic signatures:

1. Find the DSs you want to download and assign them to the device. This step is mandatory for a regular periodic download, but not required for a forced download.



2. The device downloads every assigned DS or a specific DS by regular periodic download or by on-demand forced download.
3. The device verifies the digital signature of every DS. After verification, the device stores the DS file into a nonremovable disk. This nonremovable disk can be a bootflash or hard disk, where that DS files can be read after the device is reloaded. On the routers, the DS file is stored in the bootflash:/call home directory.
4. The device continues sending periodic regular DS download requests to get the latest revision of DS and replace the older one in the device.
5. The device monitors the event and executes the actions that are defined in the DS when the event happens.

## Diagnostic Signature Events and Actions

The events and actions sections are the key areas that are used in diagnostic signatures. The event section defines all event attributes that are used for the event detection. The action section lists all the steps to be completed after the event. The actions include collecting **show** command outputs and sending them to Smart Call Home to parse.

### Diagnostic Signature Event Detection

Event detection in a DS is defined in two ways: single event detection and multiple event detection.

#### Single Event Detection

In single event detection, only one event detector is defined within a DS. The event specification format is one of the following two types:

- DS event specification type: syslog, periodic, configuration, Online Insertion Removal (OIR) immediate, and callhome are the supported event types, where “immediate” indicates that this type of DS does not detect any events, its actions are performed once it is downloaded, and the call-home type modifies the current CLI commands defined for existing alert-group.
- The Embedded Event Manager (EEM) specification type: supports any new EEM event detector without having to modify the Cisco software.

Other than using EEM to detect events, a DS is triggered when a Tool Command Language (Tcl) script is used to specify event detection types.

#### Multiple Event Detection

Multiple event detection involves defining two or more event detectors, two or more corresponding tracked object states, and a time period for the events to occur. The specification format for multiple event detection can include complex event correlation for tracked event detectors. For example, three event detectors (syslog, OIR, and IPSLA) are defined during the creation of a DS file. The correlation that is specified for these event detectors is that the DS will execute its action if both syslog and OIR events are triggered simultaneously, or if IPSLA is triggered alone.

### Diagnostic Signature Actions

The diagnostic signature (DS) file consists of various actions that must be initiated when an event occurs. The action type indicates the kind of action that will be initiated in response to a certain event.

Variables are elements within a DS file that are used to customize the files.

DS actions are categorized into the following five types:

- call-home
- command
- emailto
- script
- message

DS action types call-home and emailto collect event data and send a message to call-home servers or to the defined email addresses. The message uses "diagnostic-signature" as its message type and DS ID as the message sub-type.

The commands defined for the DS action type initiate CLI commands that can change configuration of the device, collect show command outputs, or run any EXEC command on the device. The DS action type script executes Tcl scripts.

DS action type message defines action to generate message to notify or remind user certain important information. The message could be broadcasted to all TTY lines or generated as a syslog entry.

### Action Types

DS actions are categorized into the following four types:

- Call-home
- Command
- Emailto
- Script

DS action types call-home and emailto collect event data and send a message to call-home servers or to the defined email addresses. The message includes the following elements:

- Message type—diagnostic-signature
- Message subtype—ds-id
- Message description—event-id : ds name

The commands defined for the DS action type initiates CLI commands that can change configuration of the device. The DS action type script executes Tcl scripts.

### Diagnostic Signature Variables

Variables are referenced within a DS and are used to customize the DS file. All DS variable names have the prefix ds\_ to separate them from other variables. The following are the supported DS variable types:

- System variable: variables assigned automatically by the device without any configuration changes. The Diagnostic Signatures feature supports two system variables: ds\_hostname and ds\_signature\_id.
- Environment variable: values assigned manually by using the **environment** *variable-name variable-value* command in call-home diagnostic-signature configuration mode. Use the **show call-home diagnostic-signature** command to display the name and value of all DS environment variables. If the DS file contains unresolved environment variables, this DS will stay in pending status until the variable gets resolved.
- Prompt variable: values assigned manually by using the **call-home diagnostic-signature install ds-id** command in privileged EXEC mode. If you do not set this value, the status of the DS indicates pending.

- Regular expression variable: values assigned from a regular expression pattern match with predefined CLI command outputs. The value is assigned during the DS run.
- Syslog event variable: values assigned during a syslog event detection in the DS file. This variable is valid only for syslog event detection.

## How to Configure Diagnostic Signatures

### Configuring the Service Call Home for Diagnostic Signatures

Configure the Service Call Home feature to set attributes such as the contact email address where notifications related with diagnostic signatures (DS) are sent and destination HTTP/secure HTTP (HTTPS) URL to download the DS files from.

You can also create a new user profile, configure correct attributes, and assign it as the DS profile. For periodic downloads, the request is sent out just following full inventory message. By changing the inventory periodic configuration, the DS periodic download also gets rescheduled.



---

**Note** The predefined CiscoTAC-1 profile is enabled as a DS profile by default and Cisco recommends using it. Ensure that you change the destination transport-method to the **http** setting, when you use the predefined CiscoTAC-1 profile.

---

#### Before you begin

Before you download and configure diagnostic signatures (DSs) on a device, you must ensure that the following conditions are met:

- Assign one or more DSs to the device.
- HTTP/Secure HTTP (HTTPS) transport is required for downloading DS files. Install the certification authority (CA) certificate to enable the authentication of the destination HTTPS server.



---

**Note** If you configure the trustpool feature, the CA certificate is not required.

---

#### Procedure

|        | Command or Action                                                                             | Purpose                                                                                                                    |
|--------|-----------------------------------------------------------------------------------------------|----------------------------------------------------------------------------------------------------------------------------|
| Step 1 | <p><b>enable</b></p> <p><b>Example:</b></p> <pre>Router&gt; enable</pre>                      | <p>Enables privileged EXEC mode.</p> <ul style="list-style-type: none"> <li>• Enter your password, if prompted.</li> </ul> |
| Step 2 | <p><b>configure terminal</b></p> <p><b>Example:</b></p> <pre>Router# configure terminal</pre> | <p>Enters global configuration mode.</p>                                                                                   |

|                | Command or Action                                                                                                                                                                                                                                                                                     | Purpose                                                                                                                                                                                                                                                                                                        |
|----------------|-------------------------------------------------------------------------------------------------------------------------------------------------------------------------------------------------------------------------------------------------------------------------------------------------------|----------------------------------------------------------------------------------------------------------------------------------------------------------------------------------------------------------------------------------------------------------------------------------------------------------------|
| <b>Step 3</b>  | <b>service call-home</b><br><b>Example:</b><br>Router(config)# <b>service call-home</b>                                                                                                                                                                                                               | Enables Call Home service on a device.                                                                                                                                                                                                                                                                         |
| <b>Step 4</b>  | <b>call-home</b><br><b>Example:</b><br>Router(config)# <b>call-home</b>                                                                                                                                                                                                                               | Enters Call Home configuration mode.                                                                                                                                                                                                                                                                           |
| <b>Step 5</b>  | <b>contact-email-addr</b> <i>email-address</i><br><b>Example:</b><br>Router(cfg-call-home)# <b>contact-email-addr</b><br>username@example.com                                                                                                                                                         | Assigns customer's email address. You can enter a maximum of 200 characters in email address format with no spaces.<br><br><b>Note</b> You can use any valid email address. You cannot use spaces.                                                                                                             |
| <b>Step 6</b>  | <b>mail-server</b> { <i>ipv4-address</i>   <i>name</i> } <b>priority</b> <i>number</i><br><b>Example:</b><br>Router(cfg-call-home)# <b>mail-server</b> 10.1.1.1<br>priority 4                                                                                                                         | (Optional) Configures a Simple Mail Transfer Protocol (SMTP) email server address for Call Home. This command is only used when sending email is part of the actions that are defined in any DS.                                                                                                               |
| <b>Step 7</b>  | <b>profile</b> <i>name</i><br><b>Example:</b><br>Router(cfg-call-home)# <b>profile profile1</b>                                                                                                                                                                                                       | Enters the Call Home destination profile configuration mode for the specified destination profile. If the specified destination profile does not exist, it is created.                                                                                                                                         |
| <b>Step 8</b>  | <b>destination transport-method</b> { <b>email</b>   <b>http</b> }<br><b>Example:</b><br>Router(cfg-call-home-profile)# <b>destination</b><br>transport-method email                                                                                                                                  | (Optional) Enables the message transport method. <ul style="list-style-type: none"> <li>• <b>email</b>—Sets the email message transport method.</li> <li>• <b>http</b>—Sets the HTTP message transport method.</li> </ul> <b>Note</b> To configure diagnostic signatures, you must use the <b>http</b> option. |
| <b>Step 9</b>  | <b>destination address</b> { <b>email</b> <i>email-address</i>   <b>http</b><br><i>url</i> }<br><b>Example:</b><br>Router(cfg-call-home-profile)# <b>destination address</b><br>http https://tools.cisco.com/its/<br>service/oddce/services/DDCEService                                               | Configures the destination email address or URL to which Call Home messages are sent.<br><br><b>Note</b> To configure diagnostic signatures, you must use the <b>http</b> option.                                                                                                                              |
| <b>Step 10</b> | <b>subscribe-to-alert-group</b> <b>inventory</b> [ <b>periodic</b> { <b>daily</b><br><i>hh:mm</i>   <b>monthly</b> <i>date hh:mm</i>   <b>weekly</b> <i>day</i><br><i>hh:mm</i> }]<br><b>Example:</b><br>Router(cfg-call-home-profile)#<br>subscribe-to-alert-group inventory<br>periodic daily 12:00 | Subscribes this destination profile to the Inventory alert group. The Inventory alert group can be configured for periodic notification.<br><br><b>Note</b> This command is used only for the periodic downloading of DS files.                                                                                |

**What to do next**

Set the configured profile from the previous procedure as the DS profile and configure other DS parameters.

**Configuring Diagnostic Signatures**

**Before you begin**

Configure the Service Call Home feature to set attributes for the Call Home profile. You can either use the default CiscoTAC-1 profile or use the newly created user profile.

**Procedure**

|        | Command or Action                                                                                                                                                                                                   | Purpose                                                                        |
|--------|---------------------------------------------------------------------------------------------------------------------------------------------------------------------------------------------------------------------|--------------------------------------------------------------------------------|
| Step 1 | <b>enable</b><br><b>Example:</b><br>Router> <b>enable</b>                                                                                                                                                           | Enables privileged EXEC mode.<br><br>• Enter your password, if prompted.       |
| Step 2 | <b>configure terminal</b><br><b>Example:</b><br>Router# <b>configure terminal</b>                                                                                                                                   | Enters global configuration mode.                                              |
| Step 3 | <b>call-home</b><br><b>Example:</b><br>Router(config)# <b>call-home</b>                                                                                                                                             | Enters Call Home configuration mode.                                           |
| Step 4 | <b>diagnostic-signature</b><br><b>Example:</b><br>Router(cfg-call-home)# <b>diagnostic-signature</b>                                                                                                                | Enters call-home diagnostic signature mode.                                    |
| Step 5 | <b>profile ds-profile-name</b><br><b>Example:</b><br>Router(cfg-call-home-diag-sign)# <b>profile user1</b>                                                                                                          | Specifies the destination profile on a device that DS uses.                    |
| Step 6 | <b>environment ds_env-var-name ds_env-var-value</b><br><b>Example:</b><br>Router(cfg-call-home-diag-sign)# <b>environment ds_env1 envvarval</b>                                                                     | Sets the environment variable value for DS on a device.                        |
| Step 7 | <b>end</b><br><b>Example:</b><br>Router(cfg-call-home-diag-sign)# <b>end</b>                                                                                                                                        | Exits call-home diagnostic signature mode and returns to privileged EXEC mode. |
| Step 8 | <b>call-home diagnostic-signature</b> { <b>deinstall</b>   <b>download</b> } { <i>ds-id</i>   <b>all</b> }   <b>install ds-id</b><br><b>Example:</b><br>Router# <b>call-home diagnostic-signature download 6030</b> | Downloads, installs, and uninstalls diagnostic signature files on a device.    |

|        | Command or Action                                                                                                                                                                                                                                                                                | Purpose                                                  |
|--------|--------------------------------------------------------------------------------------------------------------------------------------------------------------------------------------------------------------------------------------------------------------------------------------------------|----------------------------------------------------------|
| Step 9 | <p><b>show call-home diagnostic-signature</b> [<i>ds-id</i> [<b>actions</b>   <b>events</b>   <b>prerequisite</b>   <b>prompt</b>   <b>variables</b>]   <b>failure</b>   <b>statistics</b> [download]]</p> <p><b>Example:</b></p> <pre>Router# show call-home diagnostic-signature actions</pre> | Displays the call-home diagnostic signature information. |

## Verifying the Call Home Configuration

- **show call-home** —Displays the Call Home configuration summary.

Following is a sample output of the command:

```
Router# show call-home

Current call home settings:
  call home feature : enable
  call home message's from address: Not yet set up
  call home message's reply-to address: Not yet set up

vrf for call-home messages: Not yet set up

contact person's email address: sch-smart-licensing@cisco.com (default)

contact person's phone number: Not yet set up
street address: Not yet set up
customer ID: Not yet set up
contract ID: Not yet set up
site ID: Not yet set up

source ip address: Not yet set up
source interface: TenGigabitEthernet4/1/1
Mail-server[1]: Address: 173.36.13.143 Priority: 60
http proxy: Not yet set up

Diagnostic signature: enabled
Profile: CiscoTAC-1 (status: ACTIVE)

Smart licensing messages: enabled
Profile: CiscoTAC-1 (status: ACTIVE)

aaa-authorization: disable
aaa-authorization username: callhome (default)
data-privacy: normal
syslog throttling: enable

Rate-limit: 20 message(s) per minute

Snapshot command[0]: show cable modem summary totalb
Snapshot command[1]: show cable modem summary total

Available alert groups:
Keyword                State  Description
-----
configuration          Enable configuration info
crash                  Enable crash and traceback info
diagnostic              Enable diagnostic info
environment             Enable environmental info
```

```

inventory          Enable  inventory info
snapshot          Enable  snapshot info
syslog            Enable  syslog info
    
```

```

Profiles:
  Profile Name: CiscoTAC-1
  Profile Name: test
    
```

- **show call-home detail**—Displays the Call Home configuration in detail.

Following is a sample output of the command:

```

Router# show call-home detail

Current call home settings:
  call home feature : enable
  call home message's from address: Not yet set up
  call home message's reply-to address: Not yet set up

  vrf for call-home messages: Not yet set up

  contact person's email address: sch-smart-licensing@cisco.com (default)

  contact person's phone number: Not yet set up
  street address: Not yet set up
  customer ID: Not yet set up
  contract ID: Not yet set up
  site ID: Not yet set up

  source ip address: Not yet set up
  source interface: TenGigabitEthernet4/1/1
  Mail-server[1]: Address: 173.36.13.143 Priority: 60
  http proxy: Not yet set up

  Diagnostic signature: enabled
  Profile: CiscoTAC-1 (status: ACTIVE)

  Smart licensing messages: enabled
  Profile: CiscoTAC-1 (status: ACTIVE)

  aaa-authorization: disable
  aaa-authorization username: callhome (default)
  data-privacy: normal
  syslog throttling: enable

  Rate-limit: 20 message(s) per minute

  Snapshot command[0]: show cable modem summary totalb
  Snapshot command[1]: show cable modem summary total

Available alert groups:
  Keyword          State  Description
  -----
  configuration     Enable configuration info
  crash            Enable crash and traceback info
  diagnostic        Enable diagnostic info
  environment       Enable environmental info
  inventory         Enable inventory info
  snapshot          Enable snapshot info
  syslog            Enable syslog info

Profiles:
  Profile Name: CiscoTAC-1
    
```

```

Profile status: ACTIVE
Profile mode: Anonymous Reporting Only
Reporting Data: Smart Call Home, Smart Licensing
Preferred Message Format: xml
Message Size Limit: 3145728 Bytes
Transport Method: http
Email address(es): callhome@cisco.com
HTTP address(es): https://tools.cisco.com/its/service/oddce/services/DDCEService

Periodic configuration info message is scheduled every 17 day of the month at 09:39
    
```

```

Periodic inventory info message is scheduled every 17 day of the month at 09:24
    
```

```

Alert-group          Severity
-----
crash                debug
diagnostic           minor
environment          minor
inventory            normal

Syslog-Pattern      Severity
-----
.*                  major
    
```

- **show call-home alert-group**—Displays the available alert groups and their status.

Following is a sample output of the command:

```

Router# show call-home alert-group

Available alert groups:
Keyword          State   Description
-----
configuration    Enable configuration info
crash            Enable crash and traceback info
diagnostic       Enable diagnostic info
environment      Enable environmental info
inventory        Enable inventory info
snapshot         Enable snapshot info
syslog           Enable syslog info
    
```

- **show call-home mail-server status**—Checks and displays the availability of the configured email servers.

Following is a sample output of the command:

```

Router# show call-home mail-server status

Mail-server[1]: Address: 173.36.13.143 Priority: 60
    
```

- **show call-home profile {all | name}**—Displays the configuration of the specified destination profile. Use the keyword **all** to display the configuration of all destination profiles.

Following is a sample output of the command:

```

Router# show call-home profile CiscoTac-1

Profile Name: CiscoTAC-1
Profile status: ACTIVE
Profile mode: Full Reporting
Reporting Data: Smart Call Home, Smart Licensing
    
```



```
Preferred Message Format: xml
Message Size Limit: 3145728 Bytes
Transport Method: email
Email address(es): callhome@cisco.com
HTTP address(es): http://10.22.183.117:8080/ddce/services/DDCEService
```

Periodic configuration info message is scheduled every 17 day of the month at 09:39

Periodic inventory info message is scheduled every 17 day of the month at 09:24

```
Alert-group          Severity
-----
crash                debug
diagnostic           minor
environment          minor
inventory            normal

Syslog-Pattern      Severity
-----
.*                  major
```

- **show call-home statistics** [**detail** | **profile** *profile-name*]—Displays the statistics of Call Home events.

Following is a sample output of the command:

Router# **show call-home statistics**

| Message Types  | Total | Email | HTTP |
|----------------|-------|-------|------|
| Total Success  | 4     | 3     | 1    |
| Config         | 1     | 1     | 0    |
| Crash          | 0     | 0     | 0    |
| Diagnostic     | 0     | 0     | 0    |
| Environment    | 0     | 0     | 0    |
| Inventory      | 1     | 0     | 1    |
| Snapshot       | 0     | 0     | 0    |
| SysLog         | 2     | 2     | 0    |
| Test           | 0     | 0     | 0    |
| Request        | 0     | 0     | 0    |
| Send-CLI       | 0     | 0     | 0    |
| SCH            | 0     | 0     | 0    |
| Total In-Queue | 0     | 0     | 0    |
| Config         | 0     | 0     | 0    |
| Crash          | 0     | 0     | 0    |
| Diagnostic     | 0     | 0     | 0    |
| Environment    | 0     | 0     | 0    |
| Inventory      | 0     | 0     | 0    |
| Snapshot       | 0     | 0     | 0    |
| SysLog         | 0     | 0     | 0    |
| Test           | 0     | 0     | 0    |
| Request        | 0     | 0     | 0    |
| Send-CLI       | 0     | 0     | 0    |
| SCH            | 0     | 0     | 0    |
| Total Failed   | 0     | 0     | 0    |
| Config         | 0     | 0     | 0    |
| Crash          | 0     | 0     | 0    |
| Diagnostic     | 0     | 0     | 0    |
| Environment    | 0     | 0     | 0    |
| Inventory      | 0     | 0     | 0    |

```

Snapshot      0          0          0
SysLog        0          0          0
Test          0          0          0
Request       0          0          0
Send-CLI      0          0          0
SCH           0          0          0

Total Ratelimit
  -dropped    0          0          0
Config       0          0          0
Crash        0          0          0
Diagnostic    0          0          0
Environment  0          0          0
Inventory     0          0          0
Snapshot     0          0          0
SysLog       0          0          0
Test         0          0          0
Request      0          0          0
Send-CLI     0          0          0
SCH          0          0          0
    
```

Last call-home message sent time: 2015-03-06 18:21:49 GMT+00:00

- **show call-home diagnostic-signature**—Displays the configuration of diagnostic signature information.

Following is a sample output of the command:

```
Router# show call-home diagnostic-signature
```

```

Current diagnostic-signature settings:
Diagnostic-signature: enabled
Profile: CiscoTAC-1 (status: ACTIVE)
Environment variable:
    Not yet set up
    
```

Downloaded DSes:

| DS ID | DS Name | Revision | Status | Last Update<br>(GMT-05:00) |
|-------|---------|----------|--------|----------------------------|
| ----- | -----   | -----    | -----  | -----                      |

- **show call-home version**—Displays the Call Home version information.

Following is a sample output of the command:

```
Router# show call-home version
```

```

Call-Home Version 3.0
Component Version:
call-home: (rel4)1.0.15
eem-call-home: (rel2)1.0.5
    
```

# Configuration Example for Call Home

## Example: Call Home Configuration

Following is a configuration example for configuring the HTTPS transport:

```

ip host tools.cisco.com 72.163.4.38
vrf definition smart-vrf
!
 address-family ipv4
 exit-address-family
!
 address-family ipv6
 exit-address-family
!
interface TenGigabitEthernet4/1/1
 vrf forwarding smart-vrf
 ip address 172.22.11.25 255.255.255.128
 no ip proxy-arp
!
ip route vrf smart-vrf 72.163.4.38 255.255.255.255 172.22.11.1
!
ip http client source-interface TenGigabitEthernet4/1/1
!

```

Following is a configuration example for configuring email options:

```

call-home
 mail-server 173.36.13.143 priority 60
 source-interface TenGigabitEthernet4/1/1
 vrf smart-vrf
 alert-group-config snapshot
  add-command "show cable modem summary total"
 profile "test"
  active
  destination transport-method email
  destination address email call-home@cisco.com
  subscribe-to-alert-group configuration
  subscribe-to-alert-group crash
  subscribe-to-alert-group diagnostic severity debug
  subscribe-to-alert-group environment severity debug
  subscribe-to-alert-group inventory
  subscribe-to-alert-group syslog severity major pattern .*
  subscribe-to-alert-group syslog severity notification pattern "^.+UPDOWN.+changed state
to (down|up)$"
  subscribe-to-alert-group snapshot periodic daily 12:00
!
ip route vrf smart-vrf 173.36.13.143 255.255.255.255 172.22.11.1
!

```

## Example: Configuring HTTP Transport for Call Home on the Cisco cBR Series Router

**Step 1** Back up the current running configuration file.

**Step 2** Verify the built-in router certificates.

**Example:**

```

Router# show crypto pki trustpool | include Class 3 Public

ou=Class 3 Public Primary Certification Authority

```

## Example: Configuring HTTP Transport for Call Home on the Cisco cBR Series Router

```
ou=Class 3 Public Primary Certification Authority
```

### Step 3 (Optional) Configure VRF.

#### Example:

```
Router(config)# vrf def smart-vrf
Router(config-vrf)# address-family ipv4
Router(config-vrf-af)# exit-address-family
Router(config-vrf)# address-family ipv6
Router(config-vrf-af)# exit-address-family
```

### Step 4 Set up the network interface.

#### Example:

```
Router(config)# interface TenGigabitEthernet4/1/1
Router(config)# vrf forward smart-vrf
Router(config-if)# ip address 172.22.11.25 255.255.255.128
Router(config-if)# no ip proxy-arp
Router(config-if)# no shut
```

**Note** If IPv6 is enabled, you must configure the IPv6 address.

### Step 5 Set up the Cisco portal.

#### Example:

```
Router(config)# ip host tools.cisco.com 72.163.4.38
Router(config)# ip route vrf smart-vrf 72.163.4.38 255.255.255.255 172.22.11.1
```

### Step 6 Verify the data path.

#### Example:

```
!Verify the connectivity to TenGigabitEthernet4/1/1 interface
Router# ping vrf smart-vrf 172.22.11.25

!Verify the connectivity to TenGigabitEthernet4//1/1 gateway
Router# ping vrf smart-vrf 172.22.11.1

!Verify the connectivity to tools.cisco.com
Router# ping vrf smart-vrf 72.163.4.38
```

### Step 7 Configure the HTTP client interface.

#### Example:

```
Router(config)# ip http client source-interface TenGigabitEthernet4/1/1
```

### Step 8 Send the Call Home alert group message manually and verify the configuration.

#### Example:

```
Router# call-home send alert inventory profile CiscoTAC-1

Sending inventory info call-home message ...
Please wait. This may take some time ...

Router# show call-home statistics | include Total
Message Types      Total          Email          HTTP
```

```
Total Success 0 0 0
Total In-Queue 1 0 1
Total Failed 0 0 0
Total Ratelimit

Router# show call-home statistics | include Total
Message Types Total Email HTTP
Total Success 1 0 1
Total In-Queue 0 0 0
Total Failed 0 0 0
Total Ratelimit
```

**Step 9** Display the Call Home configuration.

**Example:**

```
Router# show call-home profile CiscoTAC-1

Profile Name: CiscoTAC-1
Profile status: ACTIVE
Profile mode: Full Reporting
Reporting Data: Smart Call Home, Smart Licensing
Preferred Message Format: xml
Message Size Limit: 3145728 Bytes
Transport Method: http
Email address(es): callhome@cisco.com
HTTP address(es): https://tools.cisco.com/its/service/oddce/services/DDCEService

Periodic configuration info message is scheduled every 15 day of the month at 15:37

Periodic inventory info message is scheduled every 15 day of the month at 15:22
Alert-group Severity
-----
crash debug
diagnostic minor
environment minor
inventory normal

Syslog-Pattern Severity
-----
.* major
```

## Example: Configuring Email Transport for Call Home on the Cisco cBR Series Router

**Step 1** Back up the current running configuration file.

**Step 2** (Optional) Configure VRF.

**Example:**

```
Router(config)# vrf def smart-vrf
Router(config-vrf)# address-family ipv4
Router(config-vrf-af)# exit-address-family
Router(config-vrf)# address-family ipv6
Router(config-vrf-af)# exit-address-family
```

**Step 3** Set up the network interface.

**Example:**

```
Router(config)# interface TenGigabitEthernet4/1/1
Router(config)# vrf forward smart-vrf
Router(config-if)# ip address 172.22.11.25 255.255.255.128
Router(config-if)# no ip proxy-arp
Router(config-if)# no shut
```

**Note** If IPv6 is enabled, you must configure the IPv6 address.

**Step 4** Verify the data path.

**Example:**

```
!Verify the connectivity to TenGigabitEthernet4/1/1 interface
Router# ping vrf smart-vrf 172.22.11.25

!Verify the connectivity to TenGigabitEthernet4//1/1 gateway
Router# ping vrf smart-vrf 172.22.11.1

!Verify the connectivity to tools.cisco.com
Router# ping vrf smart-vrf 72.163.4.38
```

**Step 5** (Optional) Configure Call Home.

**Example:**

```
Router(config)# call-home

!Configure the TenGigabitEthernet 4/1/1
Router(cfg-call-home)# source-ip-address 172.22.11.25
```

**Step 6** Configure the mail server and verify the configuration.

**Example:**

```
Router(config)# call-home
Router(cfg-call-home)# mail-server 173.36.13.143 priority 60
Router(cfg-call-home)# vrf smart-vrf
Router(cfg-call-home)# exit
Router(config)# ip route vrf smart-vrf 173.36.13.143 255.255.255.255 172.22.11.1
Router(config)# end

Router# ping vrf smart-vrf 173.36.13.143
...

Router# show call-home mail status

Please wait. Checking for mail server status ...

Mail-server[1]: Address: 173.36.13.143 Priority: 60 [Available]
```

**Note** The VRF configuration is optional.

**Step 7** Create a new destination profile and subscribe to alert the group.

**Example:**

```
Router(config)# call-home
Router(cfg-call-home)# alert-group-config snapshot
```

```
Router(cfg-call-home-snapshot)# add-command "show cable modem summary total"
Router(cfg-call-home-snapshot)# exit
Router(cfg-call-home)# profile test
Router(cfg-call-home-profile)# active
Router(cfg-call-home-profile)# destination transport-method email
Router(cfg-call-home-profile)# destination address email xyz@company.com
Router(cfg-call-home-profile)# subscribe syslog severity notification pattern "^.+UPDOWN.+changed state to (down|up)$"
Router(cfg-call-home-profile)# subscribe-to-alert-group snapshot periodic daily 12:00
Router(cfg-call-home-profile)# end
```

**Step 8** Send the Call Home alert group message manually and verify the configuration.

**Example:**

```
Router# call-home send alert-group inventory profile test
Sending inventory info call-home message ...
Please wait. This may take some time ...
```

```
Router# show call-home statistics | include Total
Message Types      Total          Email          HTTP
Total Success      1              0              1
Total In-Queue     2              2              0
Total Failed       0              0              0
Total Ratelimit
```

```
Router# show call-home statistics | include Total
Message Types      Total          Email          HTTP
Total Success      3              2              1
Total In-Queue     0              0              0
Total Failed       0              0              0
Total Ratelimit
```

**Step 9** Display the Call Home configuration.

**Example:**

```
Router# show call-home profile test

Profile Name: test
  Profile status: ACTIVE
  Profile mode: Full Reporting
  Reporting Data: Smart Call Home
  Preferred Message Format: xml
  Message Size Limit: 3145728 Bytes
  Transport Method: email
  Email address(es): abcd@company.com
  HTTP address(es): Not yet set up

  Periodic snapshot info message is scheduled daily at 12:00

Alert-group          Severity
-----
configuration        normal
crash                 debug
diagnostic            debug
environment           debug
inventory             normal
Syslog-Pattern       Severity
-----
^.+UPDOWN.+changed state
```

to (down|up)\$ notification

---

## Default Settings

*Table 331: Default Call Home Parameters*

| Parameters                                 | Default  |
|--------------------------------------------|----------|
| Call Home feature status                   | Enabled  |
| User-defined profile status                | Active   |
| Predefined CiscoTAC-1 profile status       | Active   |
| Transport method                           | HTTP     |
| Message-format type                        | XML      |
| Alert group status                         | Enabled  |
| Call Home message severity threshold       | Debug    |
| Message rate limit for messages per minute | 20       |
| AAA authorization                          | Disabled |
| Call Home syslog message throttling        | Enabled  |
| Data privacy level                         | Normal   |



# Alert Groups Trigger Events and Commands

The following table lists the supported alert groups and the default command output. The command output is included in Call Home messages that are generated for the alert group.

*Table 332: Call Home Alert Groups, Events, and Actions*

| Alert Group   | Call Home Trigger Event | Syslog Event | Severity                   | Description and Executed Commands                                                                                                                                                                                                                                                                              |
|---------------|-------------------------|--------------|----------------------------|----------------------------------------------------------------------------------------------------------------------------------------------------------------------------------------------------------------------------------------------------------------------------------------------------------------|
| Configuration | —                       | —            | <b>normal<br/>periodic</b> | Periodic events that are related to configuration sent monthly.<br>Commands executed: <ul style="list-style-type: none"> <li>• <b>show platform</b></li> <li>• <b>show version</b></li> <li>• <b>show inventory</b></li> <li>• <b>show running-config all</b></li> <li>• <b>show startup-config</b></li> </ul> |

| Alert Group | Call Home Trigger Event | Syslog Event | Severity     | Description and Executed Commands                                                                                                                                                                                                                                                                                                                                                                                                                                                                                                                                                                                                                                                                                                                                                                                                                                     |
|-------------|-------------------------|--------------|--------------|-----------------------------------------------------------------------------------------------------------------------------------------------------------------------------------------------------------------------------------------------------------------------------------------------------------------------------------------------------------------------------------------------------------------------------------------------------------------------------------------------------------------------------------------------------------------------------------------------------------------------------------------------------------------------------------------------------------------------------------------------------------------------------------------------------------------------------------------------------------------------|
| Crash       | —                       | —            | <b>debug</b> | <p>A router crash can generate events. For example, a Supervisor or line card crash.</p> <p>Commands executed:</p> <p>Crash traceback</p> <ul style="list-style-type: none"> <li>• <b>show version</b></li> <li>• <b>show logging</b></li> <li>• <b>show region</b></li> <li>• <b>show stack</b></li> </ul> <p>Crash system</p> <ul style="list-style-type: none"> <li>• <b>show version</b></li> <li>• <b>show inventory</b></li> <li>• <b>show logging</b></li> <li>• <b>show region</b></li> <li>• <b>show stack</b></li> <li>• <b>more crashinfo-file</b></li> </ul> <p>Crash module</p> <ul style="list-style-type: none"> <li>• <b>show version</b></li> <li>• <b>show inventory</b></li> <li>• <b>show platform</b></li> <li>• <b>show logging</b></li> <li>• <b>show region</b></li> <li>• <b>show stack</b></li> <li>• <b>more crashinfo-file</b></li> </ul> |

| Alert Group   | Call Home Trigger Event | Syslog Event                         | Severity | Description and Executed Commands                                                                                                                                                                                                                                                                                                                                              |
|---------------|-------------------------|--------------------------------------|----------|--------------------------------------------------------------------------------------------------------------------------------------------------------------------------------------------------------------------------------------------------------------------------------------------------------------------------------------------------------------------------------|
| Diagnostic    | —                       | —                                    | minor    | <p>Diagnostics can generate events.</p> <p>Commands executed:</p> <ul style="list-style-type: none"> <li>• <b>show platform</b></li> <li>• <b>show version</b></li> <li>• <b>show diagnostic event slot detail</b></li> <li>• <b>show inventory</b></li> <li>• <b>show buffers</b></li> <li>• <b>show logging</b></li> <li>• <b>show diagnostic events slot all</b></li> </ul> |
| Environmental | FAN_FAILURE             | CBR_PEM-6-FANOK<br>CBR_PEM-3-FANFAIL | minor    | <p>Events that are related to power, fan, and environment sensing elements, such as temperature alarms.</p> <p>Commands executed:</p> <ul style="list-style-type: none"> <li>• <b>show platform</b></li> <li>• <b>show environment</b></li> <li>• <b>show inventory</b></li> <li>• <b>show logging</b></li> </ul>                                                              |
|               | TEMPERATURE_ALARM       | ENVIRONMENTAL-1-ALERT                |          |                                                                                                                                                                                                                                                                                                                                                                                |
|               | POWER_SUPPLY_FAILURE    | CBR_PEM-6-PEMOK<br>CBR_PEM-3-PEMFAIL |          |                                                                                                                                                                                                                                                                                                                                                                                |

| Alert Group | Call Home Trigger Event     | Syslog Event | Severity      | Description and Executed Commands                                                                                                                                                                                                                                                                                                                                                                                                                                                                                                                                                                                                                                                                                                                                                                                                                                                                                                    |
|-------------|-----------------------------|--------------|---------------|--------------------------------------------------------------------------------------------------------------------------------------------------------------------------------------------------------------------------------------------------------------------------------------------------------------------------------------------------------------------------------------------------------------------------------------------------------------------------------------------------------------------------------------------------------------------------------------------------------------------------------------------------------------------------------------------------------------------------------------------------------------------------------------------------------------------------------------------------------------------------------------------------------------------------------------|
| Inventory   | OIR_REMOVE<br>OIR_INSERTION | —            | <b>normal</b> | <p>Inventory status that is provided whenever a unit is cold booted, or when FRUs are inserted or removed. This alert is considered as a noncritical event, and the information is used for status and entitlement.</p> <p>Command executed:</p> <ul style="list-style-type: none"> <li>• <b>show platform</b></li> <li>• <b>show version</b></li> <li>• <b>show inventory oid</b></li> <li>• <b>show diag all eeprom detail</b></li> <li>• <b>show interfaces</b></li> <li>• <b>show file systems</b></li> <li>• <b>show bootflash: all</b></li> <li>• <b>show data-corruption</b></li> <li>• <b>show memory statistics</b></li> <li>• <b>show process memory</b></li> <li>• <b>show process cpu</b></li> <li>• <b>show process cpu history</b></li> <li>• <b>show license udi</b></li> <li>• <b>show license detail</b></li> <li>• <b>show buffers</b></li> <li>• <b>show platform software proc slot monitor cycle</b></li> </ul> |
| Snapshot    | —                           | —            | <b>normal</b> | User-generated CLI commands.                                                                                                                                                                                                                                                                                                                                                                                                                                                                                                                                                                                                                                                                                                                                                                                                                                                                                                         |
| Syslog      | —                           | —            | <b>major</b>  | <p>Syslog messages can generate events.</p> <p>Commands executed:</p> <ul style="list-style-type: none"> <li>• <b>show inventory</b></li> <li>• <b>show logging</b></li> </ul>                                                                                                                                                                                                                                                                                                                                                                                                                                                                                                                                                                                                                                                                                                                                                       |

| Alert Group | Call Home Trigger Event | Syslog Event | Severity | Description and Executed Commands                                                                                                                                                                                               |
|-------------|-------------------------|--------------|----------|---------------------------------------------------------------------------------------------------------------------------------------------------------------------------------------------------------------------------------|
| Test        | —                       | —            | normal   | User-generated test message sent to the destination profile.<br><br>Commands executed: <ul style="list-style-type: none"> <li>• <b>show inventory</b></li> <li>• <b>show platform</b></li> <li>• <b>show version</b></li> </ul> |

## Message Contents

Smart Call Home supports the following message formats:

- Short Text Message Format
- Common Fields for Full Text and XML Messages
- Fields Specific to Alert Group Messages for Full Text and XML Messages
- Inserted Fields for a Reactive and Proactive Event Message
- Inserted Fields for an Inventory Event Message
- Inserted Fields for a User-Generated Test Message

The following table describes the short text formatting option for all the message types.

**Table 333: Short Text Message Format**

| Data Item               | Description                                             |
|-------------------------|---------------------------------------------------------|
| Device identification   | Configured device name.                                 |
| Date and time stamp     | Time stamp of the triggering event.                     |
| Error isolation message | Plain English description of triggering the event.      |
| Alarm urgency level     | Error level such as that applied to the system message. |

The following table describes the first set of common event message fields for full text or XML messages.

Table 334: Common Fields for Full Text and XML Messages

| Data Item (Plain Text and XML) | Description (Plain Text and XML)                                                                                                                                                                                                                                                                                                                                                                                                                                                                                                                              | Call-Home Message Tag (XML Only)              |
|--------------------------------|---------------------------------------------------------------------------------------------------------------------------------------------------------------------------------------------------------------------------------------------------------------------------------------------------------------------------------------------------------------------------------------------------------------------------------------------------------------------------------------------------------------------------------------------------------------|-----------------------------------------------|
| Time stamp                     | Date and time stamp of the event in the ISO time notation:<br><br><i>YYYY-MM-DD HH:MM:SS GMT + HH:MM.</i>                                                                                                                                                                                                                                                                                                                                                                                                                                                     | CallHome/EventTime                            |
| Message name                   | Name of message.                                                                                                                                                                                                                                                                                                                                                                                                                                                                                                                                              | For short text message only                   |
| Message type                   | Name of the message type, specifically "Call Home."                                                                                                                                                                                                                                                                                                                                                                                                                                                                                                           | CallHome/Event/Type                           |
| Message subtype                | Specific type of message: full, delta, test.                                                                                                                                                                                                                                                                                                                                                                                                                                                                                                                  | CallHome/Event/SubType                        |
| Message group                  | Name of the alert group, specifically "reactive." Optional, because the default is "reactive".                                                                                                                                                                                                                                                                                                                                                                                                                                                                | For long-text message only                    |
| Severity level                 | Severity level of message                                                                                                                                                                                                                                                                                                                                                                                                                                                                                                                                     | Body/Block/Severity                           |
| Source ID                      | Product type for routing through the workflow engine. The Source ID is typically the product family name.                                                                                                                                                                                                                                                                                                                                                                                                                                                     | For long-text message only                    |
| Device ID                      | Unique device identifier (UDI) for the end device that generated the message. Ensure that the field is empty if the message is nonspecific to a device. The format is <i>type@Sid@serial</i> .<br><br><ul style="list-style-type: none"> <li>• The <i>type</i> is the product model number from the backplane IDPROM.</li> <li>• @ is a separator character.</li> <li>• <i>Sid</i> is C, identifying the serial ID as a chassis serial number.</li> <li>• The Sid field identifies the <i>serial</i> number.</li> </ul> An example is<br>WS-C6509@C@12345678. | CallHome/CustomerData/ContractData/DeviceId   |
| Customer ID                    | Optional user-configurable field that is used for the contract information or other ID by any support service.                                                                                                                                                                                                                                                                                                                                                                                                                                                | CallHome/CustomerData/ContractData/CustomerId |
| Contract ID                    | Optional user-configurable field that is used for the contract information or other ID by any support service.                                                                                                                                                                                                                                                                                                                                                                                                                                                | CallHome/CustomerData/ContractData/ContractId |

| Data Item (Plain Text and XML) | Description (Plain Text and XML)                                                                                                                                                                                                                                                                                                                                                                                                                                                                                                    | Call-Home Message Tag (XML Only)                                          |
|--------------------------------|-------------------------------------------------------------------------------------------------------------------------------------------------------------------------------------------------------------------------------------------------------------------------------------------------------------------------------------------------------------------------------------------------------------------------------------------------------------------------------------------------------------------------------------|---------------------------------------------------------------------------|
| Site ID                        | Optional user-configurable field that is used for Cisco-supplied site ID or other data meaningful to alternate support service.                                                                                                                                                                                                                                                                                                                                                                                                     | CallHome/CustomerData/ContractData/SiteId                                 |
| Server ID                      | <p>If the message is generated from the device, the Server ID is the unique device identifier (UDI) of the device. The format is <i>type@Sid@serial</i>.</p> <ul style="list-style-type: none"> <li>• The <i>type</i> is the product model number from the backplane IDPROM.</li> <li>• @ is a separator character.</li> <li>• <i>Sid</i> is C, identifying the serial ID as a chassis serial number.</li> <li>• The <i>Sid</i> field identifies the <i>serial</i> number.</li> </ul> <p>An example is<br/>WS-C6509@C@12345678.</p> | For long text message only                                                |
| Message description            | Short text that describes the error.                                                                                                                                                                                                                                                                                                                                                                                                                                                                                                | CallHome/MessageDescription                                               |
| Device name                    | Node that experienced the event (hostname of the device).                                                                                                                                                                                                                                                                                                                                                                                                                                                                           | CallHome/CustomerData/SystemInfo/NameName                                 |
| Contact name                   | Name of the contact person for issues that are associated with the node that experienced the event.                                                                                                                                                                                                                                                                                                                                                                                                                                 | CallHome/CustomerData/SystemInfo/Contact                                  |
| Contact email                  | Email address of the contact person for this unit.                                                                                                                                                                                                                                                                                                                                                                                                                                                                                  | CallHome/CustomerData/SystemInfo/ContactEmail                             |
| Contact phone number           | Phone number of the contact person for this unit.                                                                                                                                                                                                                                                                                                                                                                                                                                                                                   | CallHome/CustomerData/SystemInfo/ContactPhoneNumber                       |
| Street address                 | Optional field that contains the street address for RMA part shipments that are associated with this unit.                                                                                                                                                                                                                                                                                                                                                                                                                          | CallHome/CustomerData/SystemInfo/StreetAddress                            |
| Model name                     | Model name of the device (the specific model as part of a product family name).                                                                                                                                                                                                                                                                                                                                                                                                                                                     | CallHome/Device/Cisco_Chassis/Model                                       |
| Serial number                  | Chassis serial number of the unit.                                                                                                                                                                                                                                                                                                                                                                                                                                                                                                  | CallHome/Device/Cisco_Chassis/SerialNumber                                |
| Chassis part number            | Top assembly number of the chassis.                                                                                                                                                                                                                                                                                                                                                                                                                                                                                                 | /aml/body/chassis/partNo                                                  |
| System object ID               | System Object ID that uniquely identifies the system.                                                                                                                                                                                                                                                                                                                                                                                                                                                                               | CallHome/Device/Cisco_Chassis/AdditionalInformation/AD@name="sysObjectID" |

| Data Item (Plain Text and XML) | Description (Plain Text and XML)            | Call-Home Message Tag (XML Only)                                       |
|--------------------------------|---------------------------------------------|------------------------------------------------------------------------|
| System description             | System description for the managed element. | CallHome/Device/Cisco_Chassis/AdditionalInformation/AD@name="sysDescr" |

The following table describes the fields specific to alert group messages for full text and XML. These fields may be repeated if multiple commands are executed for an alert group.

**Table 335: Fields Specific to Alert Group Messages for Full Text and XML Messages**

| Data Item (Plain Text and XML) | Description (Plain Text and XML)                      | XML Tag (XML Only)                 |
|--------------------------------|-------------------------------------------------------|------------------------------------|
| Command output name            | Exact name of the issued command.                     | /aml/attachments/attachment/name   |
| Attachment type                | The specific command output.                          | /aml/attachments/attachment/type   |
| MIME type                      | Either plain text or encoding type.                   | /aml/attachments/attachment/mime   |
| Command output text            | Output of the command that is automatically executed. | /mml/attachments/attachment/atdata |

The following table describes the event message format for full text or XML messages.

**Table 336: Inserted Fields for a Reactive and Proactive Event Message**

| Data Item (Plain Text and XML)     | Description (Plain Text and XML)                               | XML Tag (XML Only)          |
|------------------------------------|----------------------------------------------------------------|-----------------------------|
| Chassis hardware version           | Hardware version of chassis.                                   | /aml/body/chassis/hwVersion |
| Supervisor module software version | Top-level software version.                                    | /aml/body/chassis/swVersion |
| Affected FRU name                  | Name of the affected FRU that is generating the event message. | /aml/body/fru/name          |
| Affected FRU serial number         | Serial number of the affected FRU.                             | /aml/body/fru/serialNo      |
| Affected FRU part number           | Part number of the affected FRU.                               | /aml/body/fru/partNo        |
| FRU slot                           | Slot number of the FRU that is generating the event message.   | /aml/body/fru/slot          |
| FRU hardware version               | Hardware version of the affected FRU.                          | /aml/body/fru/hwVersion     |
| FRU software version               | Software version that is running on the affected FRU.          | /aml/body/fru/swVersion     |

The following table describes the inventory event message format for full text or XML messages.

**Table 337: Inserted Fields for an Inventory Event Message**

| Data Item (Plain Text and XML)     | Description (Plain Text and XML) | XML Tag (XML Only)          |
|------------------------------------|----------------------------------|-----------------------------|
| Chassis hardware version           | Hardware version of the chassis. | /aml/body/chassis/hwVersion |
| Supervisor module software version | Top-level software version.      | /aml/body/chassis/swVersion |



| Data Item (Plain Text and XML) | Description (Plain Text and XML)                               | XML Tag (XML Only)      |
|--------------------------------|----------------------------------------------------------------|-------------------------|
| FRU name                       | Name of the affected FRU that is generating the event message. | /aml/body/fru/name      |
| FRU s/n                        | Serial number of the FRU.                                      | /aml/body/fru/serialNo  |
| FRU part number                | Part number of the FRU.                                        | /aml/body/fru/partNo    |
| FRU slot                       | Slot number of the FRU.                                        | /aml/body/fru/slot      |
| FRU hardware version           | Hardware version of the FRU.                                   | /aml/body/fru/hwVersion |
| FRU software version           | Software version that is running on the FRU.                   | /aml/body/fru/swVersion |

The following table describes the user-generated test message format for full text or XML.

**Table 338: Inserted Fields for a User-Generated Test Message**

| Data Item (Plain Text and XML) | Description (Plain Text and XML)                   | XML Tag (XML Only)             |
|--------------------------------|----------------------------------------------------|--------------------------------|
| Process ID                     | Unique process ID.                                 | /aml/body/process/id           |
| Process state                  | State of process (for example, running or halted). | /aml/body/process/processState |
| Process exception              | Exception or reason code.                          | /aml/body/process/exception    |

## Sample syslog Alert Notification in XML Format

```
<?xml version="1.0" encoding="UTF-8"?>
<soap-env:Envelope
xmlns:soap-env="http://www.w3.org/2003/05/soap-envelope">
<soap-env:Header>
<aml-session:Session
xmlns:aml-session="http://www.cisco.com/2004/01/aml-session"
soap-env:mustUnderstand="true"
soap-env:role="http://www.w3.org/2003/05/soap-envelope/role/next">
<aml-session:To>http://tools.cisco.com/neddce/services/DDCEService</aml-
-session:To>
<aml-session:Path>
<aml-session:Via>http://www.cisco.com/appliance/uri</aml-session:Via>
</aml-session:Path>
<aml-session:From>http://www.cisco.com/appliance/uri</aml-session:From>
<aml-session:MessageId>MA:FXS1739Q0NR:548F4417</aml-session:MessageId>
</aml-session:Session>
</soap-env:Header>
<soap-env:Body>
<aml-block:Block
xmlns:aml-block="http://www.cisco.com/2004/01/aml-block">
<aml-block:Header>
<aml-block:Type>http://www.cisco.com/2005/05/callhome/syslog</aml-block
:Type>
<aml-block:CreationDate>2014-12-16 04:27:03
GMT+08:00</aml-block:CreationDate>
<aml-block:Builder>
<aml-block:Name>CBR8</aml-block:Name>
<aml-block:Version>2.0</aml-block:Version>
</aml-block:Builder>
<aml-block:BlockGroup>
```

```

<aml-block:GroupId>GB:FXS1739Q0NR:548F4417</aml-block:GroupId>
<aml-block:Number>0</aml-block:Number>
<aml-block:IsLast>true</aml-block:IsLast>
<aml-block:IsPrimary>true</aml-block:IsPrimary>
<aml-block:WaitForPrimary>false</aml-block:WaitForPrimary>
</aml-block:BlockGroup>
<aml-block:Severity>6</aml-block:Severity>
</aml-block:Header>
<aml-block:Content>
<ch:CallHome xmlns:ch="http://www.cisco.com/2005/05/callhome"
version="1.0">
<ch:EventTime>2014-12-16 04:26:59 GMT+08:00</ch:EventTime>
<ch:MessageDescription>Dec 16 04:26:59.885 CST: %ENVIRONMENTAL-1-ALERT:
Temp: INLET, Location: 6, State: Critical, Reading: 53
Celsius</ch:MessageDescription> <ch:Event> <ch>Type>syslog</ch>Type>
<ch:SubType></ch:SubType> <ch:Brand>Cisco Systems</ch:Brand>
<ch:Series>CBR8 Series Routers</ch:Series> </ch:Event>
<ch:CustomerData> <ch:UserData> <ch:Email>xxxx@company.com</ch:Email>
</ch:UserData>
<ch:ContractData>
<ch:CustomerId></ch:CustomerId>
<ch:SiteId></ch:SiteId>
<ch:ContractId></ch:ContractId>
<ch:DeviceId>CBR-8-CCAP-CHASS@C@FXS1739Q0NR</ch:DeviceId>
</ch:ContractData>
<ch:SystemInfo>
<ch>Name>sig-cbr</ch>Name>
<ch>Contact></ch>Contact>
<ch>ContactEmail>xxxx@company.com</ch>ContactEmail>
<ch>ContactPhoneNumber></ch>ContactPhoneNumber>
<ch:StreetAddress></ch:StreetAddress>
</ch:SystemInfo>
<ch:CCOID></ch:CCOID>
</ch:CustomerData>
<ch:Device>
<rme:Chassis xmlns:rme="http://www.cisco.com/rme/4.0">
<rme:Model>CBR-8-CCAP-CHASS</rme:Model>
<rme:HardwareVersion>0.1</rme:HardwareVersion>
<rme:SerialNumber>FXS1739Q0NR</rme:SerialNumber>
<rme:AdditionalInformation>
<rme:AD name="PartNumber" value="000-00000-00" /> <rme:AD
name="SoftwareVersion" value="15.5(20141214:005145)" /> <rme:AD
name="SystemObjectId" value="1.3.6.1.4.1.9.1.2141" /> <rme:AD
name="SystemDescription" value="Cisco IOS Software, IOS-XE Software
(X86_64_LINUX_IOSD-ADVENTERPRISEK9-M), Experimental Version
15.5(20141214:005145) [ece5_throttle_ios-ram-ece5-bk 105] Copyright (c)
1986-2014 by Cisco Systems, Inc.
Compiled Sun 14-Dec-14 00:20 by ram" /> <rme:AD name="ServiceNumber"
value="" /> <rme:AD name="ForwardAddress" value="" />
</rme:AdditionalInformation> </rme:Chassis> </ch:Device> </ch:CallHome>
</aml-block:Content> <aml-block:Attachments> <aml-block:Attachment
type="inline"> <aml-block:Name>show inventory</aml-block:Name>
<aml-block:Data encoding="plain"> <![CDATA[show inventory Load for five
secs: 2%/0%; one minute: 2%; five minutes: 2% Time source is NTP,
04:27:02.278 CST Tue Dec 16 2014
NAME: "Chassis", DESCR: "Cisco cBR-8 CCAP Chassis"
PID: CBR-8-CCAP-CHASS , VID: V01, SN: FXS1739Q0NR

NAME: "sup 0", DESCR: "Cisco cBR CCAP Supervisor Card"
PID: CBR-CCAP-SUP-160G , VID: V01, SN: CAT1736E05L

NAME: "harddisk 4/1", DESCR: "Hard Disk"
PID: UGB88RTB100HE3-BCU-DID, VID: , SN: 11000072780

```

```

NAME: "sup-pic 4/1", DESCR: "Cisco cBR CCAP Supervisor Card PIC"
PID: CBR-SUPPIC-8X10G , VID: V01, SN: CAT1735E004

NAME: "SFP+ module 4/1/0", DESCR: "iNSI xcvr"
PID: SFP+ 10GBASE-SR , VID: A , SN: FNS1727294V

NAME: "SFP+ module 4/1/1", DESCR: "iNSI xcvr"
PID: SFP+ 10GBASE-SR , VID: A , SN: FNS172727WZ

NAME: "SFP+ module 4/1/4", DESCR: "iNSI xcvr"
PID: 10GE ZR , VID: , SN: AGM120525EW

NAME: "sup 1", DESCR: "Cisco cBR CCAP Supervisor Card"
PID: CBR-CCAP-SUP-160G , VID: V01, SN: CAT1736E05L

NAME: "clc 6", DESCR: "Cisco cBR CCAP Line Card"
PID: CBR-CCAP-LC-40G , VID: V01, SN: CAT1736E0EN

NAME: "Cable PHY Module", DESCR: "CLC Downstream PHY Module 6/0"
PID: cBR-8-GEMINI , VID: V01 , SN: CSJ13152101

NAME: "Cable PHY Module", DESCR: "CLC Upstream PHY Module 6/2"
PID: cBR-8-LEOBEN , VID: V01 , SN: TST98765432

NAME: "Power Supply Module 0", DESCR: "Cisco cBR CCAP AC Power Supply"
PID: PWR-3KW-AC-V2 , VID: V02, SN: DTM173702KQ

NAME: "Power Supply Module 2", DESCR: "Cisco cBR CCAP AC Power Supply"
PID: PWR-3KW-AC-V2 , VID: V02, SN: DTM173702GD

sig-cbr#]]></aml-block:Data>
</aml-block:Attachment>
<aml-block:Attachment type="inline">
<aml-block:Name>show logging</aml-block:Name> <aml-block:Data
encoding="plain"> <![CDATA[show logging Load for five secs: 2%/0%; one
minute: 2%; five minutes: 2% Time source is NTP, 04:27:02.886 CST Tue
Dec 16 2014

Syslog logging: enabled (0 messages dropped, 51 messages rate-limited,
0 flushes, 0 overruns, xml disabled, filtering disabled)

No Active Message Discriminator.

No Inactive Message Discriminator.

Console logging: level debugging, 213 messages logged, xml disabled,
filtering disabled
Monitor logging: level debugging, 0 messages logged, xml disabled,
filtering disabled
Buffer logging: level debugging, 262 messages logged, xml disabled,
filtering disabled
Exception Logging: size (4096 bytes)
Count and timestamp logging messages: disabled
Persistent logging: disabled

No active filter modules.

Trap logging: level informational, 209 message lines logged
Logging Source-Interface: VRF Name:

```

Log Buffer (1000000 bytes):

```
*Dec 15 20:20:16.188: Rommon debug: debugFlagsStr[7], flags[0x7] *Dec
15 20:20:16.188: TRACE - Debug flag set 0x7 *Dec 15 20:20:16.188: TRACE
- Register NV N:systemInitByEvent V:True with no Callback *Dec 15
20:20:16.188: TRACE - Register NV N:routingReadyByEvent V:True with no
Callback *Dec 15 20:20:16.188: TRACE - Smart agent init started.
Version=1.2.0_dev/22
*Dec 15 20:20:16.188: ERROR - PD init failed: The requested operation
is not supported *Dec 15 20:20:16.188: ERROR - Pre Role Init Failed:
The requested operation is not supported *Dec 15 20:20:16.188: TRACE -
Smart agent init Done. status 10, state 4294967295, init 0 enable 0
Current Role Invalid *Dec 15 20:20:16.188: TRACE - Shutdown Started
*Dec 15 20:20:16.188: DEBUG - Scheduler shutdown start *Dec 15
20:20:16.188: ERROR - Failed to set shutdown watched boolean (code
Invalid argument (22)). Going the hard way!!!
*Dec 15 20:20:16.188: DEBUG - Destroying XOS stuff to exit dispatch
loop *Dec 15 20:20:16.188: DEBUG - XDM dispatch loop about to exit *Dec
15 20:20:16.188: DEBUG - Scheduler shutdown end *Dec 15 20:20:16.188:
ERROR - SmartAgent not initialized.
*Dec 15 20:20:16.188: ERROR - Smart Agent not a RF client *Dec 15
20:20:16.188: ERROR - Smart Agent not a CF client *Dec 15 20:20:16.188:
TRACE - Setting Ha Mgmt Init FALSE *Dec 15 20:20:16.188: TRACE -
Shutting down Any Role *Dec 15 20:20:17.432: (DBMS RPHA) Client
initialization; status=success *Dec 15 20:20:17.432: CABLE Parser
Trace: cable_parser_init:82 *Dec 15 20:20:17.774: ****
mcprp_ubr_punt_init: Initialized*****
-->RF_STATUS_SEND_RF_STATE received-->RF_PROG_INITIALIZATION received
*Dec 15 20:20:20.790: CWAN OIR debugging enabled (ROMMON variable
DEBUG_CWAN_OIR set)-->RF_PROG_ACTIVE_FAST
received-->RF_PROG_ACTIVE_DRAIN
received-->RF_PROG_ACTIVE_PRECONFIG
received-->received-->RF_PROG_ACTIVE_POSTCONFIG
received-->RF_PROG_ACTIVE received
*Dec 15 20:20:20.841: **** IPC port 0x1000E created!
*Dec 15 20:20:20.841: **** CIPC RP Server created UBRCCCE_CIPC_14/0 !
*Dec 15 20:20:28.294: %SPANTREE-5-EXTENDED_SYSID: Extended SysId
enabled for type vlan *Dec 15 20:20:31.944: %VOICE_HA-7-STATUS: CUBE
HA-supported platform detected.
*Dec 15 20:20:33.391: instant_msg_handle_proc_sup started!!
*Dec 15 20:20:33.391: queue_msg_handle_proc_sup started!!
*Dec 15 20:20:35.603: %IOSXE_MGMTVRF-6-CREATE_SUCCESS_INFO: Management
vrf Mgmt-intf created with ID 1, ipv4 table-id 0x1, ipv6 table-id
0x1E000001
*Dec 15 20:20:34.513: %IOSXE-6-PLATFORM: CLC4: cpp_cp: Process
CPP_PFILTER_EA_EVENT_API_CALL_REGISTER
*Dec 15 20:20:03.806: %HW_PFU-3-PFU_IDPROM_CORRUPT: R0/0: cmand: The
PEM/FM idprom could be read, but is corrupt in slot P11 The system will
run without environmental monitoring for this component *Dec 15
20:20:09.012: %SYSTEM-3-SYSTEM_SHELL_LOG: R0/0: 2014/12/15
20:20:08 : <anon>
*Dec 15 20:20:13.919: %IOSXE-4-PLATFORM: R0/0: kernel: astro: FD open
*Dec 15 20:20:13.919: %IOSXE-4-PLATFORM: R0/0: kernel: astro: astro:
mmio_start=d0000000 mmio_len=2000000
*Dec 15 20:20:13.919: %IOSXE-4-PLATFORM: R0/0: kernel: astro: Done
astro Memory map base_ptr fffffc9001660000, astro_reg_ptr fffffc9001660000...
*Dec 15 20:20:16.259: %IOSXE-4-PLATFORM: R0/0: kernel: astro: FD open
*Dec 15 20:20:16.553: %CPPHA-7-START: F0: cpp_ha: CPP 0 preparing
ucode *Dec 15 20:20:17.220: %CPPHA-7-START: F0: cpp_ha: CPP 0 startup
init *Dec 15 20:20:18.549: %PMAN-3-PROC_EMPTY_EXEC_FILE: F0: pvp.sh:
Empty executable used for process iosdb *Dec 15 20:20:20.003:
%PMAN-3-PROC_EMPTY_EXEC_FILE: CLC4: pvp.sh: Empty executable used for
process iosdb *Dec 15 20:20:20.783: %PMAN-3-PROC_EMPTY_EXEC_FILE: CLC4:
pvp.sh: Empty executable used for process iosdb *Dec 15 20:20:24.061:
```

```

%HW_PFU-3-PFU_IDPROM_CORRUPT: R0/0: cmand: The PEM/FM idprom could be
read, but is corrupt in slot P11 The system will run without
environmental monitoring for this component *Dec 15 20:20:31.722:
%CPPHA-7-START: F0: cpp_ha: CPP 0 running init *Dec 15 20:20:32.070:
%CPPHA-7-READY: F0: cpp_ha: CPP 0 loading and initialization complete
*Dec 15 20:20:36.528 UTC: TRACE - Platform EventCB invoked. EventType:
8 *Dec 15 20:20:36.528 UTC: DEBUG - Hostname changed. Old:sig-cbr
New:sig-cbr *Dec 15 20:20:36.528 UTC: %CNS IQ:0.1 ID:0
Changed:[sig-cbr] *Dec 15 20:20:36.528 UTC: %CNS IQ:0.2 ID:1
Changed:[sig-cbr] *Dec 15 20:20:36.528 UTC: %CNS IQ:0.3 ID:2
Changed:[sig-cbr] *Dec 15 20:20:36.594 UTC: %SYS-5-LOG_CONFIG_CHANGE:
Buffer logging: level debugging, xml disabled, filtering disabled, size
(1000000) *Dec 16 04:20:36.597 CST: %SYS-6-CLOCKUPDATE: System clock
has been updated from 20:20:36 UTC Mon Dec 15 2014 to 04:20:36 CST Tue
Dec 16 2014, configured from console by console.
*Dec 16 04:20:36.607 CST: spa_type 2946 ports 8 *Dec 16 04:20:36.622
CST: spa_type 2946 ports 8 *Dec 16 04:20:37.350 CST:
cmts_set_int_us_qos_flags: move US-QOS flags 0 to CDMAN *Dec 16
04:20:37.350 CST: cmts_set_int_us_default_weights: move US-QOS weights
to CDMAN *Dec 16 04:20:36.625 CST: %IOSXE-4-PLATFORM: R0/0: kernel:
astro: FD open *Dec 16 04:20:43.221 CST: %LINEPROTO-5-UPDOWN: Line
protocol on Interface Video6/0/0, changed state to up *Dec 16
04:20:43.223 CST: %LINEPROTO-5-UPDOWN: Line protocol on Interface
Video6/0/1, changed state to up *Dec 16 04:20:43.502 CST: % Redundancy
mode change to SSO

*Dec 16 04:20:43.502 CST: %VOICE_HA-7-STATUS: NONE->SSO; SSO mode will
not take effect until after a platform
reload.-->RF_STATUS_REDUNDANCY_MODE_CHANGE received *Dec 16
04:20:44.220 CST: %SYS-5-CONFIG_I: Configured from memory by console
*Dec 16 04:20:44.228 CST: %IOSXE_OIR-6-INSCARD: Card (rp) inserted in
slot R1 *Dec 16 04:20:44.229 CST: %IOSXE_OIR-6-INSCARD: Card (fp)
inserted in slot F0 *Dec 16 04:20:44.229 CST: %IOSXE_OIR-6-ONLINECARD:
Card (fp) online in slot F0 *Dec 16 04:20:44.263 CST:
%IOSXE_OIR-6-INSCARD: Card (fp) inserted in slot F1 *Dec 16
04:20:44.263 CST: %IOSXE_OIR-6-INSCARD: Card (cc) inserted in slot 4
*Dec 16 04:20:44.263 CST: %IOSXE_OIR-6-ONLINECARD: Card (cc) online in
slot 4 *Dec 16 04:20:44.264 CST: %IOSXE_OIR-6-INSCARD: Card (cc)
inserted in slot 5 *Dec 16 04:20:44.264 CST: %IOSXE_OIR-6-INSCARD: Card
(cc) inserted in slot 6 *Dec 16 04:20:44.330 CST: %IOSXE_OIR-6-INSSPA:
SPA inserted in subslot 4/1 *Dec 16 04:20:44.751 CST: %SYS-5-RESTART:
System restarted -- Cisco IOS Software, IOS-XE Software
(X86_64_LINUX_IOSD-ADVENTERPRISEK9-M), Experimental Version
15.5(20141214:005145) [ece5_throttle_ios-ram-ece5-bk 105] Copyright (c)
1986-2014 by Cisco Systems, Inc.
Compiled Sun 14-Dec-14 00:20 by ram
*Dec 16 04:20:44.775 CST: %XML-SRVC: Security Enforcement XML
Service(111) OK. PID=574
*Dec 16 04:20:44.775 CST: %SSH-5-ENABLED: SSH 1.99 has been enabled
*Dec 16 04:20:45.453 CST: %LINK-3-UPDOWN: Interface GigabitEthernet0,
changed state to up *Dec 16 04:20:45.543 CST: %LINK-5-CHANGED:
Interface TenGigabitEthernet4/1/2, changed state to administratively
down *Dec 16 04:20:45.546 CST: %LINK-5-CHANGED: Interface
TenGigabitEthernet4/1/3, changed state to administratively down *Dec 16
04:20:45.548 CST: %LINK-5-CHANGED: Interface TenGigabitEthernet4/1/4,
changed state to administratively down *Dec 16 04:20:45.551 CST:
%LINK-5-CHANGED: Interface TenGigabitEthernet4/1/5, changed state to
administratively down *Dec 16 04:20:45.571 CST: %LINK-5-CHANGED:
Interface TenGigabitEthernet4/1/6, changed state to administratively
down *Dec 16 04:20:45.574 CST: %LINK-5-CHANGED: Interface
TenGigabitEthernet4/1/7, changed state to administratively down *Dec 16
04:20:45.576 CST: %LINK-5-CHANGED: Interface TenGigabitEthernet5/1/0,
changed state to administratively down *Dec 16 04:20:45.578 CST:
%LINK-5-CHANGED: Interface TenGigabitEthernet5/1/1, changed state to

```

```

administratively down *Dec 16 04:20:45.580 CST: %LINK-5-CHANGED:
Interface TenGigabitEthernet5/1/2, changed state to administratively
down *Dec 16 04:20:45.582 CST: %LINK-5-CHANGED: Interface
TenGigabitEthernet5/1/3, changed state to administratively down *Dec 16
04:20:45.584 CST: %LINK-5-CHANGED: Interface TenGigabitEthernet5/1/4,
changed state to administratively down *Dec 16 04:20:45.586 CST:
%LINK-5-CHANGED: Interface TenGigabitEthernet5/1/5, changed state to
administratively down *Dec 16 04:20:45.588 CST: %LINK-5-CHANGED:
Interface TenGigabitEthernet5/1/6, changed state to administratively
down *Dec 16 04:20:45.590 CST: %LINK-5-CHANGED: Interface
TenGigabitEthernet5/1/7, changed state to administratively down *Dec 16
04:20:45.596 CST: %LINK-3-UPDOWN: Interface Integrated-Cable6/0/0:0,
changed state to down *Dec 16 04:20:45.602 CST: %LINK-3-UPDOWN:
Interface Integrated-Cable6/0/0:1, changed state to down *Dec 16
04:20:45.603 CST: %LINK-3-UPDOWN: Interface Integrated-Cable6/0/0:2,
changed state to down *Dec 16 04:20:45.604 CST: %LINK-3-UPDOWN:
Interface Integrated-Cable6/0/0:3, changed state to down *Dec 16
04:20:45.606 CST: %LINK-3-UPDOWN: Interface Integrated-Cable6/0/0:4,
changed state to down *Dec 16 04:20:45.607 CST: %LINK-3-UPDOWN:
Interface Integrated-Cable6/0/0:5, changed state to down *Dec 16
04:20:45.608 CST: %LINK-3-UPDOWN: Interface Integrated-Cable6/0/0:6,
changed state to down *Dec 16 04:20:45.610 CST: %LINK-3-UPDOWN:
Interface Integrated-Cable6/0/0:7, changed state to down *Dec 16
04:20:45.648 CST: %LINEPROTO-5-UPDOWN: Line protocol on Interface
Bundle1, changed state to up *Dec 16 04:20:45.649 CST: %LINK-3-UPDOWN:
Interface Bundle1, changed state to up *Dec 16 04:20:45.649 CST:
%LINK-3-UPDOWN: Interface Cable6/0/0, changed state to down *Dec 16
04:20:45.649 CST: %SNMP-5-LINK_DOWN: LinkDown:Interface
Cable6/0/0 changed state to down
*Dec 16 04:20:45.666 CST: %LINK-3-UPDOWN: Interface
Wideband-Cable6/0/0:0, changed state to down *Dec 16 04:20:45.666 CST:
%LINK-3-UPDOWN: Interface Wideband-Cable6/0/0:1, changed state to down
*Dec 16 04:20:45.681 CST: %LINK-3-UPDOWN: Interface
Wideband-Cable6/0/0:2, changed state to down *Dec 16 04:20:45.681 CST:
%LINK-3-UPDOWN: Interface Wideband-Cable6/0/0:3, changed state to down
*Dec 16 04:20:45.681 CST: %LINK-3-UPDOWN: Interface
Wideband-Cable6/0/0:4, changed state to down *Dec 16 04:20:45.681 CST:
%LINK-3-UPDOWN: Interface Wideband-Cable6/0/0:5, changed state to down
*Dec 16 04:20:45.682 CST: %LINK-3-UPDOWN: Interface
Wideband-Cable6/0/0:6, changed state to down *Dec 16 04:20:45.682 CST:
%LINK-3-UPDOWN: Interface Wideband-Cable6/0/0:7, changed state to down
*Dec 16 04:20:45.685 CST: %LINK-3-UPDOWN: Interface
Integrated-Cable6/0/1:0, changed state to down *Dec 16 04:20:45.694
CST: %LINK-3-UPDOWN: Interface Integrated-Cable6/0/1:1, changed state
to down *Dec 16 04:20:45.694 CST: %LINK-3-UPDOWN: Interface Cable6/0/1,
changed state to down *Dec 16 04:20:45.694 CST: %SNMP-5-LINK_DOWN:
LinkDown:Interface
Cable6/0/1 changed state to down
*Dec 16 04:20:45.699 CST: %LINK-3-UPDOWN: Interface
Wideband-Cable6/0/1:0, changed state to down *Dec 16 04:20:45.703 CST:
%LINK-3-UPDOWN: Interface Wideband-Cable6/0/1:1, changed state to down
*Dec 16 04:20:45.706 CST: %LINK-3-UPDOWN: Interface
Integrated-Cable6/0/1:2, changed state to down *Dec 16 04:20:45.707
CST: %LINK-3-UPDOWN: Interface Integrated-Cable6/0/1:3, changed state
to down *Dec 16 04:20:45.709 CST: %LINK-3-UPDOWN: Interface
Wideband-Cable6/0/2:0, changed state to down *Dec 16 04:20:46.469 CST:
%SNMP-5-COLDSTART: SNMP agent on host sig-cbr is undergoing a cold
start *Dec 16 04:20:46.472 CST: %LINEPROTO-5-UPDOWN: Line protocol on
Interface GigabitEthernet0, changed state to up *Dec 16 04:20:46.543
CST: %LINEPROTO-5-UPDOWN: Line protocol on Interface
TenGigabitEthernet4/1/2, changed state to down *Dec 16 04:20:46.546
CST: %LINEPROTO-5-UPDOWN: Line protocol on Interface
TenGigabitEthernet4/1/3, changed state to down *Dec 16 04:20:46.548
CST: %LINEPROTO-5-UPDOWN: Line protocol on Interface

```

```

TenGigabitEthernet4/1/4, changed state to down *Dec 16 04:20:46.551
CST: %LINEPROTO-5-UPDOWN: Line protocol on Interface
TenGigabitEthernet4/1/5, changed state to down *Dec 16 04:20:46.571
CST: %LINEPROTO-5-UPDOWN: Line protocol on Interface
TenGigabitEthernet4/1/6, changed state to down *Dec 16 04:20:46.574
CST: %LINEPROTO-5-UPDOWN: Line protocol on Interface
TenGigabitEthernet4/1/7, changed state to down *Dec 16 04:20:46.576
CST: %LINEPROTO-5-UPDOWN: Line protocol on Interface
TenGigabitEthernet5/1/0, changed state to down *Dec 16 04:20:46.578
CST: %LINEPROTO-5-UPDOWN: Line protocol on Interface
TenGigabitEthernet5/1/1, changed state to down *Dec 16 04:20:46.580
CST: %LINEPROTO-5-UPDOWN: Line protocol on Interface
TenGigabitEthernet5/1/2, changed state to down *Dec 16 04:20:46.582
CST: %LINEPROTO-5-UPDOWN: Line protocol on Interface
TenGigabitEthernet5/1/3, changed state to down *Dec 16 04:20:46.584
CST: %LINEPROTO-5-UPDOWN: Line protocol on Interface
TenGigabitEthernet5/1/4, changed state to down *Dec 16 04:20:46.586
CST: %LINEPROTO-5-UPDOWN: Line protocol on Interface
TenGigabitEthernet5/1/5, changed state to down *Dec 16 04:20:46.588
CST: %LINEPROTO-5-UPDOWN: Line protocol on Interface
TenGigabitEthernet5/1/6, changed state to down *Dec 16 04:20:46.590
CST: %LINEPROTO-5-UPDOWN: Line protocol on Interface
TenGigabitEthernet5/1/7, changed state to down *Dec 16 04:20:46.641
CST: %SYS-6-BOOTTIME: Time taken to reboot after reload = 374 seconds
*Dec 16 04:20:53.697 CST: %IOSXE-1-PLATFORM: R0/0: kernel: Raptor MAC
image download wrote 55917152 bytes *Dec 16 04:21:23.432 CST:
%TRANSCIEVER-6-INSERTED: CLC4: iomd:
transceiver module inserted in TenGigabitEthernet4/1/0 *Dec 16
04:21:23.435 CST: %TRANSCIEVER-6-INSERTED: CLC4: iomd:
transceiver module inserted in TenGigabitEthernet4/1/1 *Dec 16
04:21:23.440 CST: %TRANSCIEVER-6-INSERTED: CLC4: iomd:
transceiver module inserted in TenGigabitEthernet4/1/4 *Dec 16
04:21:29.430 CST: %CBRDIT-5-DTISLOT: DTI slot 4/1: card role changed to
Active

*Dec 16 04:21:29.454 CST: %SPA_OIR-6-ONLINECARD: SPA (CBR-SUPPIC-8X10G)
online in subslot 4/1 *Dec 16 04:21:31.403 CST: %LINK-3-UPDOWN:
Interface TenGigabitEthernet4/1/0, changed state to up *Dec 16
04:21:31.405 CST: %CBR SPA-7-RAPTOR_ESI_EGRESS_HDR_LO_INTERRUPT:
CLC4: iomd: LOCAL RAPTOR, DP 0, channel_not_found_err *Dec 16
04:21:31.412 CST: %LINK-3-UPDOWN: Interface TenGigabitEthernet4/1/1,
changed state to up *Dec 16 04:21:32.403 CST: %LINEPROTO-5-UPDOWN: Line
protocol on Interface TenGigabitEthernet4/1/0, changed state to up *Dec
16 04:21:32.412 CST: %LINEPROTO-5-UPDOWN: Line protocol on Interface
TenGigabitEthernet4/1/1, changed state to up *Dec 16 04:21:41.171 CST:
%IOSXE-3-PLATFORM: R0/0: kernel: i801_smbus
0000:00:1f.3: Transaction timeout
*Dec 16 04:21:41.174 CST: %IOSXE-3-PLATFORM: R0/0: kernel:
/nobackup/ram/ece5-bk/binos/os/linux/drivers/binos/i2c/max3674/max3674_
mai n.c:show_reg_pll (line 88): show_reg_pll failed *Dec 16
04:21:58.237 CST: %IOSXE-5-PLATFORM: CLC6: cdman: Basestar FPGA rev_id
0x00000002, fpga_rev_id 0x00000032 *Dec 16 04:21:59.074 CST:
%CMRP-3-BAD_ID_HW: R0/0: cmand: Failed Identification Test in CBR
linecard. The module linecard slot 6 in this router may not be a
genuine Cisco product. Cisco warranties and support programs only apply
to genuine Cisco products. If Cisco determines that your insertion of
non-Cisco memory, WIC cards, AIM cards, Network Modules, SPA cards,
GBICs or other modules into a Cisco product is the cause of a support
issue, Cisco may deny support under your warranty or under a Cisco
support pro *Dec 16 04:21:59.075 CST: %IOSXE_OIR-6-ONLINECARD: Card
(cc) online in slot 6 *Dec 16 04:22:08.825 CST:
%ASR1000_INFRA-3-EOBC SOCK: CLC6:
ubrclc-k9lc-ms: Socket event for EO6/0/1, fd 11, failed to bind;
Address already in use success *Dec 16 04:22:09.605 CST: SNMP IPC

```

```

session up(RP <-> slot 6)!
*Dec 16 04:22:09.605 CST: CMTS IPC session up!
*Dec 16 04:22:14.564 CST: %SNMP-5-LINK_UP: LinkUp:Interface
Cable6/0/0-upstream0 changed state to up *Dec 16 04:22:14.565 CST:
%SNMP-5-LINK_UP: LinkUp:Interface
Cable6/0/0-upstream1 changed state to up *Dec 16 04:22:14.566 CST:
%SNMP-5-LINK_UP: LinkUp:Interface
Cable6/0/2-upstream0 changed state to up *Dec 16 04:22:14.566 CST:
%SNMP-5-LINK_UP: LinkUp:Interface
Cable6/0/2-upstream1 changed state to up *Dec 16 04:22:15.051 CST:
%SNMP-5-LINK_UP: LinkUp:Interface Cable6/0/0 changed state to up *Dec
16 04:22:15.258 CST: %SNMP-5-LINK_UP: LinkUp:Interface Cable6/0/1
changed state to up *Dec 16 04:22:15.258 CST: %SNMP-5-LINK_UP:
LinkUp:Interface Cable6/0/2 changed state to up *Dec 16 04:22:15.259
CST: %SNMP-5-LINK_UP: LinkUp:Interface Cable6/0/3 changed state to up
*Dec 16 04:22:15.259 CST: %SNMP-5-LINK_UP: LinkUp:Interface Cable6/0/4
changed state to up *Dec 16 04:22:15.411 CST: %SNMP-5-LINK_UP:
LinkUp:Interface Cable6/0/5 changed state to up *Dec 16 04:22:15.411
CST: %SNMP-5-LINK_UP: LinkUp:Interface Cable6/0/6 changed state to up
*Dec 16 04:22:15.411 CST: %SNMP-5-LINK_UP: LinkUp:Interface Cable6/0/7
changed state to up *Dec 16 04:22:15.411 CST: %SNMP-5-LINK_UP:
LinkUp:Interface Cable6/0/8 changed state to up *Dec 16 04:22:15.432
CST: %SNMP-5-LINK_UP: LinkUp:Interface Cable6/0/9 changed state to up
*Dec 16 04:22:15.432 CST: %SNMP-5-LINK_UP: LinkUp:Interface Cable6/0/10
changed state to up *Dec 16 04:22:15.433 CST: %SNMP-5-LINK_UP:
LinkUp:Interface Cable6/0/11 changed state to up *Dec 16 04:22:15.433
CST: %SNMP-5-LINK_UP: LinkUp:Interface Cable6/0/12 changed state to up
*Dec 16 04:22:15.433 CST: %SNMP-5-LINK_UP: LinkUp:Interface Cable6/0/13
changed state to up *Dec 16 04:22:15.433 CST: %SNMP-5-LINK_UP:
LinkUp:Interface Cable6/0/14 changed state to up *Dec 16 04:22:15.433
CST: %SNMP-5-LINK_UP: LinkUp:Interface Cable6/0/15 changed state to up
*Dec 16 04:22:15.677 CST: %LINEPROTO-5-UPDOWN: Line protocol on
Interface Cable6/0/8, changed state to up *Dec 16 04:22:15.678 CST:
%LINEPROTO-5-UPDOWN: Line protocol on Interface Cable6/0/9, changed
state to up *Dec 16 04:22:15.901 CST: %LINEPROTO-5-UPDOWN: Line
protocol on Interface Cable6/0/10, changed state to up *Dec 16
04:22:15.902 CST: %LINEPROTO-5-UPDOWN: Line protocol on Interface
Cable6/0/11, changed state to up *Dec 16 04:22:15.902 CST:
%LINEPROTO-5-UPDOWN: Line protocol on Interface Cable6/0/12, changed
state to up *Dec 16 04:22:15.903 CST: %LINEPROTO-5-UPDOWN: Line
protocol on Interface Cable6/0/13, changed state to up *Dec 16
04:22:15.903 CST: %LINEPROTO-5-UPDOWN: Line protocol on Interface
Cable6/0/14, changed state to up *Dec 16 04:22:15.904 CST:
%LINEPROTO-5-UPDOWN: Line protocol on Interface Cable6/0/15, changed
state to up *Dec 16 04:22:17.046 CST: %LINEPROTO-5-UPDOWN: Line
protocol on Interface Cable6/0/0, changed state to up *Dec 16
04:22:17.047 CST: %LINK-3-UPDOWN: Interface Cable6/0/0, changed state
to up *Dec 16 04:22:17.256 CST: %LINEPROTO-5-UPDOWN: Line protocol on
Interface Cable6/0/1, changed state to up *Dec 16 04:22:17.257 CST:
%LINK-3-UPDOWN: Interface Cable6/0/1, changed state to up *Dec 16
04:22:17.259 CST: %LINEPROTO-5-UPDOWN: Line protocol on Interface
Cable6/0/2, changed state to up *Dec 16 04:22:17.260 CST:
%LINK-3-UPDOWN: Interface Cable6/0/2, changed state to up *Dec 16
04:22:17.260 CST: %LINEPROTO-5-UPDOWN: Line protocol on Interface
Cable6/0/3, changed state to up *Dec 16 04:22:17.260 CST:
%LINK-3-UPDOWN: Interface Cable6/0/3, changed state to up *Dec 16
04:22:17.260 CST: %LINEPROTO-5-UPDOWN: Line protocol on Interface
Cable6/0/4, changed state to up *Dec 16 04:22:17.260 CST:
%LINK-3-UPDOWN: Interface Cable6/0/4, changed state to up *Dec 16
04:22:17.411 CST: %LINEPROTO-5-UPDOWN: Line protocol on Interface
Cable6/0/5, changed state to up *Dec 16 04:22:17.411 CST:
%LINK-3-UPDOWN: Interface Cable6/0/5, changed state to up *Dec 16
04:22:17.411 CST: %LINEPROTO-5-UPDOWN: Line protocol on Interface
Cable6/0/6, changed state to up *Dec 16 04:22:17.411 CST:

```



```

%LINK-3-UPDOWN: Interface Cable6/0/6, changed state to up *Dec 16
04:22:17.411 CST: %LINEPROTO-5-UPDOWN: Line protocol on Interface
Cable6/0/7, changed state to up *Dec 16 04:22:17.412 CST:
%LINK-3-UPDOWN: Interface Cable6/0/7, changed state to up *Dec 16
04:22:16.714 CST: %IOSXE-5-PLATFORM: CLC6: cdman: DS-JIB:ILK Interrupts
Enabled. (Init:20539, Check:9566 1stPKO:8942) *Dec 16 04:22:17.809 CST:
%CMRP-3-IDPROM_SENSOR: R0/0: cmand: One or more sensor fields from the
idprom failed to parse properly because Invalid argument.
Dec 16 04:22:57.161 CST: %SNMP-5-LINK_DOWN: LinkDown:Interface
Integrated-Cable6/0/0-downstream0 changed state to down Dec 16
04:22:57.161 CST: %SNMP-5-LINK_DOWN: LinkDown:Interface
Integrated-Cable6/0/0-downstream1 changed state to down Dec 16
04:22:57.161 CST: %SNMP-5-LINK_DOWN: LinkDown:Interface
Integrated-Cable6/0/0-downstream2 changed state to down Dec 16
04:22:57.162 CST: %SNMP-5-LINK_DOWN: LinkDown:Interface
Integrated-Cable6/0/0-downstream3 changed state to down Dec 16
04:22:57.162 CST: %SNMP-5-LINK_DOWN: LinkDown:Interface
Integrated-Cable6/0/0-downstream4 changed state to down Dec 16
04:22:57.162 CST: %SNMP-5-LINK_DOWN: LinkDown:Interface
Integrated-Cable6/0/0-downstream5 changed state to down Dec 16
04:22:57.162 CST: %SNMP-5-LINK_DOWN: LinkDown:Interface
Integrated-Cable6/0/0-downstream6 changed state to down Dec 16
04:22:57.162 CST: %SNMP-5-LINK_DOWN: LinkDown:Interface
Integrated-Cable6/0/0-downstream7 changed state to down Dec 16
04:22:57.163 CST: %SNMP-5-LINK_DOWN: LinkDown:Interface
Integrated-Cable6/0/0-downstream8 changed state to down Dec 16
04:22:57.163 CST: %SNMP-5-LINK_DOWN: LinkDown:Interface
Integrated-Cable6/0/0-downstream9 changed state to down Dec 16
04:22:57.163 CST: %SNMP-5-LINK_DOWN: LinkDown:Interface
Integrated-Cable6/0/0-downstream10 changed state to down Dec 16
04:22:57.163 CST: %SNMP-5-LINK_DOWN: LinkDown:Interface
Integrated-Cable6/0/1-downstream0 changed state to down Dec 16
04:22:57.164 CST: %SNMP-5-LINK_DOWN: LinkDown:Interface
Integrated-Cable6/0/1-downstream1 changed state to down Dec 16
04:22:57.164 CST: %SNMP-5-LINK_DOWN: LinkDown:Interface
Integrated-Cable6/0/1-downstream2 changed state to down Dec 16
04:22:57.164 CST: %SNMP-5-LINK_DOWN: LinkDown:Interface
Integrated-Cable6/0/1-downstream3 changed state to down Dec 16
04:22:57.164 CST: %SNMP-5-LINK_DOWN: LinkDown:Interface
Integrated-Cable6/0/1-downstream4 changed state to down Dec 16
04:22:57.164 CST: %SNMP-5-LINK_DOWN: LinkDown:Interface
Integrated-Cable6/0/1-downstream5 changed state to down Dec 16
04:22:57.183 CST: %SNMP-5-LINK_UP: LinkUp:Interface
Integrated-Cable6/0/0-downstream0 changed state to up Dec 16
04:22:57.184 CST: %SNMP-5-LINK_UP: LinkUp:Interface
Integrated-Cable6/0/0-downstream1 changed state to up Dec 16
04:22:57.189 CST: %SNMP-5-LINK_UP: LinkUp:Interface
Integrated-Cable6/0/0-downstream2 changed state to up Dec 16
04:22:57.211 CST: %SNMP-5-LINK_UP: LinkUp:Interface
Integrated-Cable6/0/0-downstream3 changed state to up Dec 16
04:22:57.212 CST: %SNMP-5-LINK_UP: LinkUp:Interface
Integrated-Cable6/0/0-downstream4 changed state to up Dec 16
04:22:57.212 CST: %SNMP-5-LINK_UP: LinkUp:Interface
Integrated-Cable6/0/0-downstream6 changed state to up Dec 16
04:22:57.213 CST: %SNMP-5-LINK_UP: LinkUp:Interface
Integrated-Cable6/0/0-downstream7 changed state to up Dec 16
04:22:57.213 CST: %SNMP-5-LINK_UP: LinkUp:Interface
Integrated-Cable6/0/0-downstream8 changed state to up Dec 16
04:22:57.213 CST: %SNMP-5-LINK_UP: LinkUp:Interface
Integrated-Cable6/0/0-downstream9 changed state to up Dec 16
04:22:57.213 CST: %SNMP-5-LINK_UP: LinkUp:Interface
Integrated-Cable6/0/0-downstream10 changed state to up Dec 16
04:22:57.214 CST: %SNMP-5-LINK_UP: LinkUp:Interface
Integrated-Cable6/0/1-downstream0 changed state to up Dec 16
    
```

```

04:22:57.424 CST: %SNMP-5-LINK_UP: LinkUp:Interface
Integrated-Cable6/0/1-downstream1 changed state to up Dec 16
04:22:57.426 CST: %SNMP-5-LINK_UP: LinkUp:Interface
Integrated-Cable6/0/1-downstream2 changed state to up Dec 16
04:22:57.435 CST: %SNMP-5-LINK_UP: LinkUp:Interface
Integrated-Cable6/0/1-downstream3 changed state to up Dec 16
04:22:57.437 CST: %SNMP-5-LINK_UP: LinkUp:Interface
Integrated-Cable6/0/1-downstream4 changed state to up Dec 16
04:22:57.449 CST: %SNMP-5-LINK_UP: LinkUp:Interface
Integrated-Cable6/0/1-downstream5 changed state to up Dec 16
04:22:59.219 CST: %LINEPROTO-5-UPDOWN: Line protocol on Interface
Integrated-Cable6/0/1:0, changed state to up Dec 16 04:22:59.219 CST:
%LINK-3-UPDOWN: Interface Integrated-Cable6/0/1:0, changed state to up
Dec 16 04:22:59.427 CST: %LINEPROTO-5-UPDOWN: Line protocol on
Interface Integrated-Cable6/0/1:1, changed state to up Dec 16
04:22:59.427 CST: %LINK-3-UPDOWN: Interface Integrated-Cable6/0/1:1,
changed state to up Dec 16 04:22:59.449 CST: %LINEPROTO-5-UPDOWN: Line
protocol on Interface Wideband-Cable6/0/0:0, changed state to up Dec 16
04:22:59.450 CST: %LINK-3-UPDOWN: Interface Wideband-Cable6/0/0:0,
changed state to up Dec 16 04:22:59.450 CST: %LINK-3-UPDOWN: Interface
Wideband-Cable6/0/0:1, changed state to up Dec 16 04:22:59.450 CST:
%LINK-3-UPDOWN: Interface Wideband-Cable6/0/0:2, changed state to up
Dec 16 04:22:59.450 CST: %LINK-3-UPDOWN: Interface
Wideband-Cable6/0/0:3, changed state to up Dec 16 04:22:59.450 CST:
%LINK-3-UPDOWN: Interface Wideband-Cable6/0/0:4, changed state to up
Dec 16 04:22:59.450 CST: %LINK-3-UPDOWN: Interface
Wideband-Cable6/0/0:5, changed state to up Dec 16 04:22:59.451 CST:
%LINK-3-UPDOWN: Interface Wideband-Cable6/0/0:6, changed state to up
Dec 16 04:22:59.451 CST: %LINK-3-UPDOWN: Interface
Wideband-Cable6/0/0:7, changed state to up Dec 16 04:22:59.451 CST:
%LINEPROTO-5-UPDOWN: Line protocol on Interface Wideband-Cable6/0/1:0,
changed state to up Dec 16 04:22:59.451 CST: %LINK-3-UPDOWN: Interface
Wideband-Cable6/0/1:0, changed state to up Dec 16 04:22:59.451 CST:
%LINEPROTO-5-UPDOWN: Line protocol on Interface Wideband-Cable6/0/1:1,
changed state to up Dec 16 04:22:59.452 CST: %LINK-3-UPDOWN: Interface
Wideband-Cable6/0/1:1, changed state to up Dec 16 04:22:59.452 CST:
%LINK-3-UPDOWN: Interface Wideband-Cable6/0/2:0, changed state to up
Dec 16 04:23:27.352 CST: %IOSXE-5-PLATFORM: CLC6: cdman: DSPHY Gemini
module 1 was not present Dec 16 04:26:59.885 CST:
%ENVIRONMENTAL-1-ALERT: Temp: INLET, Location:
6, State: Critical, Reading: 53 Celsius sig-cbr#]]></aml-block:Data>
</aml-block:Attachment> </aml-block:Attachments> </aml-block:Block>
</soap-env:Body> </soap-env:Envelope>
    
```

## Additional References

### Related Documents

| Related Topic                                                                                                                                                                                                                                                       | Document Title                             |
|---------------------------------------------------------------------------------------------------------------------------------------------------------------------------------------------------------------------------------------------------------------------|--------------------------------------------|
| Smart Call Home site page on Cisco.com for access to all related product information.                                                                                                                                                                               | <a href="#">Cisco Smart Call Home site</a> |
| The User Guide explains how the Smart Call Home service offers web-based access to important information on select Cisco devices. The User Guide also describes the higher network availability and increased operational efficiency by providing real-time alerts. | <a href="#">Smart Call Home User Guide</a> |

| Related Topic               | Document Title                                                                               |
|-----------------------------|----------------------------------------------------------------------------------------------|
| Call Home Quick Start Guide | <a href="#">Smart Call Home Quick Start Configuration Guide for Cisco cBR Series Routers</a> |

**MIBs**

| MIB                | MIBs Link                                                                                                                                                                                                                  |
|--------------------|----------------------------------------------------------------------------------------------------------------------------------------------------------------------------------------------------------------------------|
| CISCO-CALLHOME-MIB | To locate and download MIBs for selected platforms, Cisco IOS releases, and feature sets, use Cisco MIB Locator found at the following URL:<br><br><a href="http://www.cisco.com/go/mibs">http://www.cisco.com/go/mibs</a> |

**Technical Assistance**

| Description                                                                                                                                                                                                                                                                                                                                                                                                                                                                                                                                                                         | Link                                                                    |
|-------------------------------------------------------------------------------------------------------------------------------------------------------------------------------------------------------------------------------------------------------------------------------------------------------------------------------------------------------------------------------------------------------------------------------------------------------------------------------------------------------------------------------------------------------------------------------------|-------------------------------------------------------------------------|
| <p>The Cisco Support website provides extensive online resources, including documentation and tools for troubleshooting and resolving technical issues with Cisco products and technologies.</p> <p>You can subscribe to various services to receive security and technical information about your products. The services include the Product Alert Tool (accessed from Field Notices), the Cisco Technical Services Newsletter, and Really Simple Syndication (RSS) Feeds.</p> <p>Access to most tools on the Cisco Support website requires a Cisco.com user ID and password.</p> | <a href="http://www.cisco.com/support">http://www.cisco.com/support</a> |

## Feature Information for Call Home

Use Cisco Feature Navigator to find information about the platform support and software image support. Cisco Feature Navigator enables you to determine which software images support a specific software release, feature set, or platform. To access Cisco Feature Navigator, go to the <https://cfmg.cisco.com/> link. An account on the Cisco.com page is not required.



**Note** The following table lists the software release in which a given feature is introduced. Unless noted otherwise, subsequent releases of that software release train also support that feature.

*Table 339: Feature Information for Call Home*

| Feature Name    | Releases                    | Feature Information                                                                                                   |
|-----------------|-----------------------------|-----------------------------------------------------------------------------------------------------------------------|
| Smart Call Home | Cisco IOS XE Everest 16.6.1 | This feature was integrated into the Cisco IOS XE Everest 16.6.1 on the Cisco cBR Series Converged Broadband Routers. |





# CHAPTER 107

## Platform Automated Monitoring

- [Platform Automated Monitoring, on page 1737](#)

## Platform Automated Monitoring

Table 340: Feature History

| Feature Name                              | Release Information          | Feature Description                                                                                                                                                                                                                                                                                                                                                                                                                                                                                                                                                                                                                                                                                                                         |
|-------------------------------------------|------------------------------|---------------------------------------------------------------------------------------------------------------------------------------------------------------------------------------------------------------------------------------------------------------------------------------------------------------------------------------------------------------------------------------------------------------------------------------------------------------------------------------------------------------------------------------------------------------------------------------------------------------------------------------------------------------------------------------------------------------------------------------------|
| Support For Platform Automated Monitoring | Cisco IOS XE Dublin 17.12.1y | <p>With this release, cBR-8 supports Platform Automated Monitoring (PAM), which is a system monitoring tool that is integrated with Cisco IOS XE Software image to monitor the following issues:</p> <ul style="list-style-type: none"><li>• Process Crashes</li><li>• When StandbySUP cannot bootup</li></ul> <p>PAM is an IOSd-process running on the Supervisor Card (SUP) to periodically monitor the system's crash. When an RP/FP/CC crashinfo or corefile is detected, the syslog displays on the active SUP's IOSd console.</p> <p>The benefit of PAM is that you can use a script (for example, EEM) to monitor PAM and automatically submit a TAC case and share the core/crashinfo with TAC, when a crash event is detected.</p> |

### PAM Process

PAM is an IOSd-process running on the Supervisor Card (SUP) to periodically monitor the system's crash. Use the **show process | in PAM** command to check if the PAM process is running:

```
router#show process | in PAM
 314 Mwe 633F12E936BA 142300 563398 252 15808/24000 0 CBR PAM Process
```

The preceding output is a sample showing an example of the cbr-8 PAM process already running.

A hidden **\*.pam file** is created in the `/harddisk/core/` path. This is an empty file which is used to record the last monitored timestamp of the PAM process. Only the `corefile/crashinfo` whose timestamp is newer than the **\*.pam file** timestamp, is considered processed by PAM.

Use the following command to view the **\*.pam file** file.

```
router#dir harddisk:core
Directory of harddisk:/core/

4751365  -rw-                1  Feb 20 2024 13:56:27 +08:00  .pam
```

PAM process handles two timers:

- **5-minute Periodical Timer:** PAM initiates a 5 minute to check the new `crashinfo/corefile` on both active and standby SUP. The following messages are possible outputs which can be displayed on the SUP's IOSd console:

- Initial Message

```
%PAM-4-TEMP_CORE: PAM detects a new core file %s start to dump at %-27s.
Need to wait for several minutes to get the full core file.
```

- This is an example of a successful dump of a core file case:

```
%PAM-3-CRASH: PAM detects crash <crashinfo or corefile path>
```

- This is an example of an incomplete dump of a core file case:

```
%PAM-3-CORE_UNCOMPLETE: PAM detects core file <uncomplete core file path> doesn't
generate successfully.
```

- Here is a sample output that is displayed on the console:

```
router#dir harddisk:core
Directory of harddisk:/core/

2981892  -rw-                11010048  Feb 20 2024 23:23:22 +08:00
router_SIP_1_vidman_7014_1704986383.core.gz.TEMP_IN_PROGRESS
3080199  -rw-                1  Feb 20 2024 23:19:51 +08:00  .pam
2981891  -rw-                7884800  Feb 20 2024 23:19:46 +08:00
router_SIP_1_vidman_7014_1704986383.core
2981889  -rw-                0  Feb 20 2024 23:19:46 +08:00
router_SIP_1_vidman%cc_1_0%0.TEMP_IN_PROGRESS
```

```
Feb 20 23:19:51.179 CST: %PAM-4-TEMP_CORE: PAM detects a new core file
harddisk:core/router_SIP_1_vidman_7014_1704986383.core
start to dump at Feb 20 2024 23:19:47 +08:00. Need to wait for several minutes to get
the full core file.
```

```
Feb 20 23:29:51.397 CST: %PAM-3-CRASH: PAM detects crash for process vidman on fru CC
slot 1,
path: harddisk:core/router_SIP_1_vidman_7014_1704986383.core.gz
```

```
router#
```

- **30 Minutes One Time Timer:** This timer begins when the standby SUP initializes with a bootup image. If the boot fails and the timer expires, then the following error message about the standby SUP bootup failure displays:

```
%PAM-3-FAILURE: StandbySUP stuck at booting state for 30 minutes.
```

### Location and Format of the Crashinfo Or Corefile

The following tables show the Location and Format of the Crashinfo Or Corefile with examples:

**Table 341: Crashinfo**

| Type                  | Location and Format With Example                                                                                                                                                                                                                                                               |
|-----------------------|------------------------------------------------------------------------------------------------------------------------------------------------------------------------------------------------------------------------------------------------------------------------------------------------|
| cdman<br>crashinfo    | harddisk:<hostname>_SIP_<slot>_cdman_crashinfo_XXX.log<br>Example:<br>harddisk:L08_SIP_6_cdman_crashinfo_7437_09152023155523.log                                                                                                                                                               |
| iosd-clc<br>crashinfo | harddisk:Slot-<slot>-0_crashinfo_SIP_<slot>_XXX.log<br>Example:<br>harddisk:Slot-0-0_crashinfo_SIP_00_00_20230905-155430-CST                                                                                                                                                                   |
| sup-iosd<br>crashinfo | bootflash:<hostname>_crashinfo_RP_<slot>_XXX<br>Example:<br>bootflash:L08_crashinfo_RP_01_00_20221201-191258-EDT<br>Sample Console Message:<br>%PAM-3-CRASH: PAM detects crash for process linux_iosd-image on fru RP slot<br>0,<br>path: bootflash:L08_crashinfo_RP_00_00_20240129-153213-CST |

**Table 342: Corefile**

| Type                        | Location and Format With Example                                                                                                                                                                                                                                                                                                                                                                                                                                                                                                                                                                                                                                                                                          |
|-----------------------------|---------------------------------------------------------------------------------------------------------------------------------------------------------------------------------------------------------------------------------------------------------------------------------------------------------------------------------------------------------------------------------------------------------------------------------------------------------------------------------------------------------------------------------------------------------------------------------------------------------------------------------------------------------------------------------------------------------------------------|
| Linecard<br>process<br>core | harddisk:core/<hostname>_SIP_<slot>_<process_name>_<pid>_XXX.core.gz<br>Examples:<br>harddisk:core/L08_SIP_1_ubrclc-k91c-ms_8030_1698622516.core.gz<br>harddisk:core/RPCC01_SIP_2_CDM_PKTIO_7481_1700073874.core.gz                                                                                                                                                                                                                                                                                                                                                                                                                                                                                                       |
| RP process<br>core          | harddisk:core/<hostname>_<process_name>_<pid>_XXX.core.gz<br>Examples:<br>harddisk:core/L08_dbm_19549_20231122-100257-CST.core.gz<br>harddisk:core/L08_fman_fp_image_28299_20231019-200127-MST.core.gz<br>harddisk:core/L08_cpp_cp_svr_27953_20231019-200045-MST.core.gz<br>Sample Console Messages:<br>Jan 11 23:19:51.179 CST: %PAM-4-TEMP_CORE: PAM detects a new core file<br>harddisk:core/L08_SIP_1_vidman_7014_1704986383.core start to dump at Jan 11 2024<br>23:19:47 +08:00.<br>Need to wait for several minutes to get the full core file.<br>Jan 11 23:29:51.397 CST: %PAM-3-CRASH: PAM detects crash for process vidman on<br>fru CC slot 1,<br>path: harddisk:core/L08_SIP_1_vidman_7014_1704986383.core.gz |

| Type                 | Location and Format With Example                                                                                                                                                                                                                                                                                                                                                                                               |
|----------------------|--------------------------------------------------------------------------------------------------------------------------------------------------------------------------------------------------------------------------------------------------------------------------------------------------------------------------------------------------------------------------------------------------------------------------------|
| Incomplete core file | <p>harddisk:core/&lt;hostname&gt;_&lt;process_name&gt;_&lt;pid&gt;_xxx.core</p> <p>Examples:</p> <p>harddisk:core/L08_SIP_1_cdman_7797_1701140043.core</p> <p>harddisk:core/L08_SIP_1_cdman%cc_1_0%0.TEMP_IN_PROGRESS</p> <p>Sample Console Messages:</p> <p>Jan 12 20:44:14.315 CST: %PAM-3-CORE_UNCOMPLETE: PAM detects core file<br/>harddisk:core/L08_SIP_1_CDM_RT_7802_1705062593.core doesn't generate successfully.</p> |

Table 343: Kernel Core

| Type        | Location and Format With Example                                                                                                                                                                                                                                                                                                                                                                                                                                                                                                                                                                                                                                                                                                                                                                                                                                                                                     |
|-------------|----------------------------------------------------------------------------------------------------------------------------------------------------------------------------------------------------------------------------------------------------------------------------------------------------------------------------------------------------------------------------------------------------------------------------------------------------------------------------------------------------------------------------------------------------------------------------------------------------------------------------------------------------------------------------------------------------------------------------------------------------------------------------------------------------------------------------------------------------------------------------------------------------------------------|
| Kernel Core | <p>harddisk:core/kernel.CC_CYLONS_&lt;slot&gt;_&lt;timestamp&gt;.core.flat.gz</p> <p>harddisk:core/kernel.RP_CBR_&lt;slot&gt;_&lt;timestamp&gt;.core.flat.gz</p> <p>Examples:</p> <p>harddisk:core/kernel.CC_CYLONS_6_20231026003938.txt</p> <p>harddisk:core/kernel.CC_CYLONS_6_20231026003938.core.flat.gz</p> <p>harddisk:core/kernel.RP_CBR_1_20230126014834.core.flat.gz</p> <p>harddisk:core/kernel.RP_CBR_1_20230126014834.txt</p> <p>Sample Console Messages:</p> <p>Jan 11 23:44:52.451 CST: %PAM-4-TEMP_CORE: PAM detects a new core file<br/>harddisk:core/kernel.CC_CYLONS_1.core.TEMP_IN_PROGRESS start to dump at Jan 11<br/>2024 23:44:49 +08:00.<br/>Need to wait for several minutes to get the full core file.</p> <p>Jan 11 23:49:52.684 CST: %PAM-3-CRASH: PAM detects crash for process kernel on<br/>fru CC slot 1,<br/>path: harddisk:core/kernel.CC_CYLONS_1_20240111154328.core.flat.gz</p> |



Table 344: StandbySUP Crash or Core

| StandbySUP Crash or Core | Location and Format With Example                                                                                                                                                                                                                                                                                                                                                                                                                                                                                                                      |
|--------------------------|-------------------------------------------------------------------------------------------------------------------------------------------------------------------------------------------------------------------------------------------------------------------------------------------------------------------------------------------------------------------------------------------------------------------------------------------------------------------------------------------------------------------------------------------------------|
| Kernel Core              | <p>stby-harddisk:core/&lt;hostname&gt;_&lt;process_name&gt;_&lt;pid&gt;_xxx.core.gz</p> <p>Examples:</p> <p>stby-harddisk:core/L08_dbm_19549_20231122-100257-CST.core.gz</p> <p>Sample Console Messages:</p> <pre>Jan 12 14:44:30.949 CST: %PAM-3-CRASH: PAM detects crash for process cpp on fru RP slot 1, path: stby-harddisk:core/L08_cpp_cp_svr_21886_20240112-142857-CST.core.gz</pre> <p><b>Note</b> If ActiveSUP crashes after a SUPSO event, then a new ActiveSUP can also detect and report the old ActiveSUP's crashinfo or core file.</p> |

**Limitations of PAM**

- If you configure the **exception crashinfo file** command, then this feature does not work.
 

Configuring the **exception crashinfo file** command allows you to define a custom prefix of the crashinfo file. PAM cannot detect such crashinfo since it cannot know which process/fru/slot crash happened.
- If the standbySUP cannot bootup, PAM cannot cover the following cases:
  - StandbySUP is removed intentionally.
  - StandbySUP is inserted and under ROMMON state without bootup image. This may occur due to **config-register** configured as **0x0**.
  - StandbySUP is inserted but stops responding and does not have a bootup image. This may occur due to a hardware issue.

In releases before Cisco IOS XE Dublin 17.12.1y, there is no support for a unified syslog, which covers all modules or processes crash. You must manually filter several syslogs to obtain the relevant log information and manually submit the log files to TAC.





## CHAPTER 108

# SNMP Support over VPNs—Context-Based Access Control

---

The SNMP Support over VPNs--Context-Based Access Control feature provides infrastructure for the multiple SNMP context supports in Cisco software and VPN-aware MIB.

- [Finding Feature Information, on page 1743](#)
- [Hardware Compatibility Matrix for the Cisco cBR Series Routers, on page 1743](#)
- [Restrictions for SNMP Support over VPNs—Context-Based Access Control, on page 1745](#)
- [Information About SNMP Support over VPNs—Context-Based Access Control, on page 1745](#)
- [How to Configure SNMP Support over VPNs—Context-Based Access Control, on page 1748](#)
- [Configuration Examples for SNMP Support over VPNs—Context-Based Access Control, on page 1751](#)
- [Additional References, on page 1752](#)
- [Feature Information for SNMP Support over VPNs—Context-Based Access Control, on page 1754](#)

## Finding Feature Information

Your software release may not support all the features that are documented in this module. For the latest feature information and caveats, see the release notes for your platform and software release. The Feature Information Table at the end of this document provides information about the documented features and lists the releases in which each feature is supported.

Use Cisco Feature Navigator to find information about platform support and Cisco software image support. To access Cisco Feature Navigator, go to <http://tools.cisco.com/ITDIT/CFN/>. An account on <http://www.cisco.com/> is not required.

## Hardware Compatibility Matrix for the Cisco cBR Series Routers



---

**Note** The hardware components that are introduced in a given Cisco IOS-XE Release are supported in all subsequent releases unless otherwise specified.

---

Table 345: Hardware Compatibility Matrix for the Cisco cBR Series Routers

| Cisco CMTS Platform                    | Processor Engine                                                                                                                                                                                  | Interface Cards                                                                                                                                                                                                                                                                                                                                                                                                                                                                                                                                                                                                                                                                                                                                                                                 |
|----------------------------------------|---------------------------------------------------------------------------------------------------------------------------------------------------------------------------------------------------|-------------------------------------------------------------------------------------------------------------------------------------------------------------------------------------------------------------------------------------------------------------------------------------------------------------------------------------------------------------------------------------------------------------------------------------------------------------------------------------------------------------------------------------------------------------------------------------------------------------------------------------------------------------------------------------------------------------------------------------------------------------------------------------------------|
| Cisco cBR-8 Converged Broadband Router | <p><b>Cisco IOS-XE Release 16.5.1 and Later Releases</b></p> <p>Cisco cBR-8 Supervisor:</p> <ul style="list-style-type: none"> <li>• PID—CBR-SUP-250G</li> <li>• PID—CBR-CCAP-SUP-160G</li> </ul> | <p><b>Cisco IOS-XE Release 16.5.1 and Later Releases</b></p> <p>Cisco cBR-8 CCAP Line Cards:</p> <ul style="list-style-type: none"> <li>• PID—CBR-LC-8D30-16U30</li> <li>• PID—CBR-LC-8D31-16U30</li> <li>• PID—CBR-RF-PIC</li> <li>• PID—CBR-RF-PROT-PIC</li> <li>• PID—CBR-CCAP-LC-40G</li> <li>• PID—CBR-CCAP-LC-40G-R</li> <li>• PID—CBR-CCAP-LC-G2-R</li> <li>• PID—CBR-SUP-8X10G-PIC</li> <li>• PID—CBR-2X100G-PIC</li> </ul> <p>Digital PICs:</p> <ul style="list-style-type: none"> <li>• PID—CBR-DPIC-8X10G</li> <li>• PID—CBR-DPIC-2X100G</li> </ul> <p>Cisco cBR-8 Downstream PHY Module:</p> <ul style="list-style-type: none"> <li>• PID—CBR-D31-DS-MOD</li> </ul> <p>Cisco cBR-8 Upstream PHY Modules:</p> <ul style="list-style-type: none"> <li>• PID—CBR-D31-US-MOD</li> </ul> |



**Note** Do not use DPICs (8X10G and 2x100G) to forward IP traffic, as it may cause buffer exhaustion, leading to line card reload.

The only allowed traffic on a DPIC interface is DEPI, UEPI, and GCP traffic from the Cisco cBR-8 router to Remote PHY devices. Other traffic such as DHCP, SSH, and UTSC should flow via another router, since DPICs cannot be used for normal routing.

# Restrictions for SNMP Support over VPNs—Context-Based Access Control

- If you delete an SNMP context using the **no snmp-server context** command, all SNMP instances in that context are deleted.
- Not all MIBs are VPN-aware.

## Information About SNMP Support over VPNs—Context-Based Access Control

### SNMP Versions and Security

Cisco software supports the following versions of SNMP:

- **SNMPv1**—Simple Network Management Protocol: a full Internet standard, which is defined in RFC 1157. (RFC 1157 replaces the earlier versions that were published as RFC 1067 and RFC 1098.) Security is based on the community strings.
- **SNMPv2c**—The community string-based Administrative Framework for SNMPv2. SNMPv2c (the "c" is for "community") is an experimental IP that is defined in RFC 1901, RFC 1905, and RFC 1906. SNMPv2c is an update of the protocol operations and data types of SNMPv2p (SNMPv2 Classic) and uses the community-based security model of SNMPv1.

For more information about SNMP versions, see the “Configuring SNMP Support” module in the *Cisco Network Management Configuration Guide*.

### SNMPv1 or SNMPv2 Security

Cisco IOS software supports the following versions of SNMP:

- **SNMPv1**—Simple Network Management Protocol: a full Internet standard, that is defined in RFC 1157. (RFC 1157 replaces the earlier versions that were published as RFC 1067 and RFC 1098.) Security is based on the community strings.
- **SNMPv2c**—The community string-based Administrative Framework for SNMPv2. SNMPv2c (the "c" is for "community") is an experimental IP that is defined in RFC 1901, RFC 1905, and RFC 1906. SNMPv2c is an update of the protocol operations and data types of SNMPv2p (SNMPv2 Classic) and uses the community-based security model of SNMPv1.

SNMPv1 and SNMPv2 are not as secure as SNMPv3. SNMP version 1 and 2 use plain text communities and do not perform the authentication or security checks that SNMP version 3 performs. When using SNMP version 1 or 2, associate a community name with a VPN to configure the SNMP Support over VPNs—Context-Based Access Control feature. This association causes SNMP to process requests coming in for a particular community string only if it comes in from the configured VRF. Community strings without an associated VRF in the incoming packets are processed only if it came through a non-VRF interface. This

process prevents users outside the VPN from snooping a clear text community string to query the VPN's data. These methods of source address validation are not as secure as using SNMPv3.

## SNMPv3 Security

If you are using SNMPv3, the security name must be associated with authentication or privileged passwords. Source address validation is not performed on SNMPv3 users. Configure a minimum security level of AuthNoPriv. This configuration ensures that the VPN accesses only to context associated with it and cannot see the MIB data of other VPNs.

On a provider edge (PE) router, a community can be associated with a VRF to provide the source address validation. Associate source address with the community list by using an access control list, if the source address validation is required on a customer edge (CE) router.

If you are using SNMPv3, the security name or security password of the users of a VPN must be unknown to users of other VPNs. Cisco recommends not to use SNMPv3 nonauthorized users if you need security of management information.

## SNMP Notification Support over VPNs

The SNMP Notification Support over VPNs feature allows the sending and receiving of SNMP notifications (traps and informs) using VPN routing and forwarding (VRF) instance tables. In particular, this feature adds support to Cisco software for the sending and receiving of SNMP notifications (traps and informs) specific to individual VPNs.

SNMP is an application-layer protocol that provides a message format for communication between SNMP managers and agents.

A VPN is a network that provides high-connectivity transfers on a shared system with the same usage guidelines as a private network. A VPN can be built on the Internet over IP, Frame Relay, or ATM networks.

A VRF stores per-VPN routing data. It defines the VPN membership of a customer site that is attached to the network access server (NAS). The VRF consists of an IP routing table and a derived Cisco Express Forwarding (formerly known as CEF) table. VRF also consists of guidelines and routing protocol parameters that control the information that is included in the routing table.

The SNMP Support for VPNs—Context-Based Access Control feature provides configuration commands that allow you to associate SNMP agents and managers with specific VRFs. The associated VRF is used for the sending of SNMP notifications (traps and informs) and responses between agents and managers. If a VRF is not specified, the default routing table for the VPN is used.

## VPN-Aware SNMP

The SNMP Support for VPNs—Context-Based Access Control feature extends the capabilities of the SNMP Notification Support for VPNs feature and enables SNMP to differentiate between incoming packets from different VPNs.

When the SNMP Support for VPNs—Context-Based Access Control feature is configured, SNMP accepts requests on any configured VRF and returns responses to the same VRF. A trap host can be associated with a specific VRF. The configured VRF is then used for sending out traps; otherwise, the default routing table is used. You can also associate a remote user with a specific VRF. You can also configure the VRFs from which SNMP accepts requests. Any requests coming from VRFs that are not specified are dropped.

IP access lists can be configured and associated with SNMP community strings. This feature enables you to configure an association between VRF instances with SNMP community strings. When a VRF instance is associated with an SNMP community string, SNMP processes the requests coming in for a particular community string only if the requests are received from the configured VRF. If the community string in the incoming packet does not have a VRF associated with it, the community string must come through a non-VRF interface.

You can also enable or disable authentication traps for SNMP packets dropped due to VRF mismatches. By default if SNMP authentication traps are enabled, VRF authentication traps are also enabled.

## VPN Route Distinguishers

A route distinguisher (RD) creates routing and forwarding tables and specifies the default route distinguisher for a VPN. The RD is added to the beginning of your IPv4 prefixes to change them into globally unique VPN-IPv4 prefixes.

The RD is an autonomous system number (ASN)-relative RD, in which case it comprises an autonomous system number and an arbitrary number. Or, the RD is an IP-address-relative RD, in which case it comprises an IP address and an arbitrary number.

You can enter an RD in either of these formats:

- 16-bit ASN: your 16-bit number: For example, 101:3.
- 32-bit IP address: your 32-bit number: For example, 192.168.122.15:1.

## SNMP Contexts

SNMP contexts provide VPN users with a secure way of accessing MIB data. When a VPN is associated with a context, that VPN's specific MIB data exists in that context. Associating a VPN with a context enables service providers to manage networks with multiple VPNs. Creating and associating a context with a VPN makes it unique. The context enables a provider to prevent the users of one VPN from accessing information about other VPN users on the same networking device.

VPN-aware SNMP requires an agreement between SNMP manager and agent entities operating in a VPN environment. The agreement ensures mapping between the SNMP security name and the VPN ID. This mapping is created by using multiple contexts for the SNMP data of different VPNs through the configuration of the SNMP-VACM-MIB. The SNMP-VACM-MIB is configured with views. This configuration allows VPN users with a security name access to the restricted object space. The configuration is associated with your access type in the context that is associated with the user of that VPN.

SNMP request messages undergo three phases of security and access control. Once the access is validated, a response message is sent back with the object values in the context of a VPN:

- In the first phase, the username is authenticated. This phase ensures that the user is authenticated and authorized for SNMP access.
- In the second phase, the user is authorized for the SNMP access that is requested to the group objects under consideration of the configured SNMP context. This phase is called the access control phase.
- In the third phase, access is made to an instance of a table entry. With this third phase, complete retrieval can be based on the SNMP context name.

# How to Configure SNMP Support over VPNs—Context-Based Access Control

## Configuring an SNMP Context and Associating the SNMP Context with a VPN

Perform this task to configure an SNMP context and to associate the SNMP context with a VPN.



**Note**

- Only the following MIBs are context-aware. All the tables in these MIBs can be polled:
  - CISCO-IPSEC-FLOW-MONITOR-MIB
  - CISCO-IPSEC-MIB
  - CISCO-PING-MIB
  - IP-FORWARD-MIB
  - MPLS-LDP-MIB
- Only two SNMP variables in the IP-FORWARD-MIB can be polled: 1.3.6.1.2.1.4.24.3 (ipCidrRouteNumber - Scalar) and 1.3.6.1.2.1.4.24.4.1 (ipCidrRouteEntry - Table).

**Procedure**

|               | Command or Action                                                                                                 | Purpose                                                                                                            |
|---------------|-------------------------------------------------------------------------------------------------------------------|--------------------------------------------------------------------------------------------------------------------|
| <b>Step 1</b> | <b>enable</b><br><b>Example:</b><br>Device> enable                                                                | Enables privileged EXEC mode. <ul style="list-style-type: none"> <li>• Enter your password if prompted.</li> </ul> |
| <b>Step 2</b> | <b>configure terminal</b><br><b>Example:</b><br>Device# configure terminal                                        | Enters global configuration mode.                                                                                  |
| <b>Step 3</b> | <b>snmp-server context</b> <i>context-name</i><br><b>Example:</b><br>Device(config)# snmp-server context context1 | Creates and names an SNMP context.                                                                                 |
| <b>Step 4</b> | <b>vrf definition</b> <i>vrf-name</i><br><b>Example:</b><br>Device(config)# vrf definition vrf1                   | Configures a VRF routing table and enters VRF configuration mode.                                                  |
| <b>Step 5</b> | <b>rd</b> <i>route-distinguisher</i><br><b>Example:</b>                                                           | Creates a VPN route distinguisher.                                                                                 |



|               | Command or Action                                                                                                                                                               | Purpose                                                                                                                                                                                                                                                        |
|---------------|---------------------------------------------------------------------------------------------------------------------------------------------------------------------------------|----------------------------------------------------------------------------------------------------------------------------------------------------------------------------------------------------------------------------------------------------------------|
|               | Device(config-vrf)# rd 100:120                                                                                                                                                  |                                                                                                                                                                                                                                                                |
| <b>Step 6</b> | <b>context</b> <i>context-name</i><br><b>Example:</b><br>Device(config-vrf)# context context1                                                                                   | Associates an SNMP context with a particular VRF.<br><b>Note</b> The <b>snmp context</b> command is used instead of the <b>context</b> command, depending on your release. See the <i>Cisco IOS Network Management Command Reference</i> for more information. |
| <b>Step 7</b> | <b>route-target</b> { <b>import</b>   <b>export</b>   <b>both</b> }<br><i>route-target-ext-community</i><br><b>Example:</b><br>Device(config-vrf)# route-target export 100:1000 | (Optional) Creates a route-target extended community for a VRF.                                                                                                                                                                                                |
| <b>Step 8</b> | <b>end</b><br><b>Example:</b><br>Device(config-vrf)# end                                                                                                                        | Exits interface mode and enters global configuration mode.                                                                                                                                                                                                     |
| <b>Step 9</b> | <b>end</b><br><b>Example:</b><br>Device(config)# end                                                                                                                            | Exits global configuration mode.                                                                                                                                                                                                                               |

## Configuring SNMP Support and Associating an SNMP Context

Perform this task to configure SNMP support and associate it with an SNMP context.

### SUMMARY STEPS

- enable**
- configure terminal**
- snmp-server user** *username group-name* [**remote** *host* [**udp-port** *port*] [**vrf** *vrf-name*]] {**v1** | **v2c** | **v3** [**encrypted**] [**auth** {**md5** | **sha**} *auth-password*]} [**access** [**ipv6** *nacl*] [**priv** {**des** | **3des** | **aes** {**128** | **192** | **256**}}] *privpassword*] {*acl-number* | *acl-name*}]
- snmp-server group** *group-name* {**v1** | **v2c** | **v3** {**auth** | **noauth** | **priv**}} [**context** *context-name*] [**read** *read-view*] [**write** *write-view*] [**notify** *notify-view*] [**access** [**ipv6** *named-access-list*] [*acl-number* | *acl-name*]]
- snmp-server view** *view-name oid-tree* {**included** | **excluded**}
- snmp-server enable traps** [*notification-type*] [**vrrp**]
- snmp-server community** *string* [**view** *view-name*] [**ro** | **rw**] [**ipv6** *nacl*] [*access-list-number* | *extended-access-list-number* | *access-list-name*]
- snmp-server host** {*hostname* | *ip-address*} [**vrf** *vrf-name*] [**traps** | **informs**] [**version** {**1** | **2c** | **3** [**auth** | **noauth** | **priv**]}] *community-string* [**udp-port** *port*] [*notification-type*]
- snmp mib community-map** *community-name* [**context** *context-name*] [**engineid** *engine-id*] [**security-name** *security-name*][**target-list** *upn-list-name*]
- snmp mib target list** *vpn-list-name* {**vrf** *vrf-name* | **host** *ip-address*}

## 11. no snmp-server trap authentication vrf

### DETAILED STEPS

|               | Command or Action                                                                                                                                                                                                                                                                                                                                                                                                                                                                                                                      | Purpose                                                                                                                                                                                                                                                        |
|---------------|----------------------------------------------------------------------------------------------------------------------------------------------------------------------------------------------------------------------------------------------------------------------------------------------------------------------------------------------------------------------------------------------------------------------------------------------------------------------------------------------------------------------------------------|----------------------------------------------------------------------------------------------------------------------------------------------------------------------------------------------------------------------------------------------------------------|
| <b>Step 1</b> | <b>enable</b><br><b>Example:</b><br>Device> enable                                                                                                                                                                                                                                                                                                                                                                                                                                                                                     | Enables privileged EXEC mode. <ul style="list-style-type: none"> <li>• Enter your password if prompted.</li> </ul>                                                                                                                                             |
| <b>Step 2</b> | <b>configure terminal</b><br><b>Example:</b><br>Device# configure terminal                                                                                                                                                                                                                                                                                                                                                                                                                                                             | Enters global configuration mode.                                                                                                                                                                                                                              |
| <b>Step 3</b> | <b>snmp-server user</b> <i>username group-name</i> [ <b>remote host</b> [ <b>udp-port port</b> ] [ <b>vrf vrf-name</b> ]] { <b>v1</b>   <b>v2c</b>   <b>v3</b> [ <b>encrypted</b> ] [ <b>auth</b> { <b>md5</b>   <b>sha</b> } <i>auth-password</i> ]} [ <b>access</b> [ <b>ipv6 nacl</b> ] [ <b>priv</b> { <b>des</b>   <b>3des</b>   <b>aes</b> { <b>128</b>   <b>192</b>   <b>256</b> } } <i>privpassword</i> ] [ <i>acl-number</i>   <i>acl-name</i> ]}]<br><b>Example:</b><br>Device(config)# snmp-server user customer1 group1 v1 | Configures a new user to an SNMP group.                                                                                                                                                                                                                        |
| <b>Step 4</b> | <b>snmp-server group</b> <i>group-name</i> { <b>v1</b>   <b>v2c</b>   <b>v3</b> { <b>auth</b>   <b>noauth</b>   <b>priv</b> }} [ <b>context context-name</b> ] [ <b>read read-view</b> ] [ <b>write write-view</b> ] [ <b>notify notify-view</b> ] [ <b>access</b> [ <b>ipv6 named-access-list</b> ] [ <i>acl-number</i>   <i>acl-name</i> ]]]<br><b>Example:</b><br>Device(config)# snmp-server group group1 v1 context context1 read view1 write view1 notify view1                                                                  | Configures a new SNMP group or a table that maps SNMP users to SNMP views. <ul style="list-style-type: none"> <li>• Use the <b>context context-name</b> keyword argument pair to associate the specified SNMP group with a configured SNMP context.</li> </ul> |
| <b>Step 5</b> | <b>snmp-server view</b> <i>view-name oid-tree</i> { <b>included</b>   <b>excluded</b> }<br><b>Example:</b><br>Device(config)# snmp-server view view1 ipForward included                                                                                                                                                                                                                                                                                                                                                                | Creates or updates a view entry.                                                                                                                                                                                                                               |
| <b>Step 6</b> | <b>snmp-server enable traps</b> [ <i>notification-type</i> ] [ <b>vrrp</b> ]<br><b>Example:</b><br>Device(config)# snmp-server enable traps                                                                                                                                                                                                                                                                                                                                                                                            | Enables all SNMP notifications (traps or informs) available on your system.                                                                                                                                                                                    |
| <b>Step 7</b> | <b>snmp-server community</b> <i>string</i> [ <b>view view-name</b> ] [ <b>ro</b>   <b>rw</b> ] [ <b>ipv6 nacl</b> ] [ <i>access-list-number</i>   <i>extended-access-list-number</i>   <i>access-list-name</i> ]                                                                                                                                                                                                                                                                                                                       | Sets up the community access string to permit access to the SNMP.                                                                                                                                                                                              |

|                | Command or Action                                                                                                                                                                                                                                                                                                                                                                                             | Purpose                                                                                                                                                                                                                                                                                                                          |
|----------------|---------------------------------------------------------------------------------------------------------------------------------------------------------------------------------------------------------------------------------------------------------------------------------------------------------------------------------------------------------------------------------------------------------------|----------------------------------------------------------------------------------------------------------------------------------------------------------------------------------------------------------------------------------------------------------------------------------------------------------------------------------|
|                | <p><b>Example:</b></p> <pre>Device(config)# snmp-server community public view1 rw</pre>                                                                                                                                                                                                                                                                                                                       |                                                                                                                                                                                                                                                                                                                                  |
| <b>Step 8</b>  | <p><b>snmp-server host</b> <i>{hostname   ip-address}</i> [<b>vrf</b> <i>vrf-name</i>] [<b>traps   informs</b>] [<b>version</b> {<b>1</b>   <b>2c</b>   <b>3</b> [<b>auth</b>   <b>noauth</b>   <b>priv</b>]}] <i>community-string</i> [<b>udp-port</b> <i>port</i>] [<i>notification-type</i>]</p> <p><b>Example:</b></p> <pre>Device(config)# snmp-server host 10.0.0.1 vrf vrf1 public udp-port 7002</pre> | Specifies the recipient of an SNMP notification operation.                                                                                                                                                                                                                                                                       |
| <b>Step 9</b>  | <p><b>snmp mib community-map</b> <i>community-name</i> [<b>context</b> <i>context-name</i>] [<b>engineid</b> <i>engine-id</i>] [<b>security-name</b> <i>security-name</i>][<b>target-list</b> <i>upn-list-name</i>]</p> <p><b>Example:</b></p> <pre>Device(config)# snmp mib community-map community1 context context1 target-list commAVpn</pre>                                                             | Associates an SNMP community with an SNMP context, Engine ID, or security name.                                                                                                                                                                                                                                                  |
| <b>Step 10</b> | <p><b>snmp mib target list</b> <i>vpn-list-name</i> {<b>vrf</b> <i>vrf-name</i>   <b>host</b> <i>ip-address</i>}</p> <p><b>Example:</b></p> <pre>Device(config)# snmp mib target list commAVpn vrf vrf1</pre>                                                                                                                                                                                                 | Creates a list of target VRFs and hosts to associate with an SNMP community.                                                                                                                                                                                                                                                     |
| <b>Step 11</b> | <p><b>no snmp-server trap authentication vrf</b></p> <p><b>Example:</b></p> <pre>Device(config)# no snmp-server trap authentication vrf</pre>                                                                                                                                                                                                                                                                 | <p>(Optional) Disables all SNMP authentication notifications (traps and informs) generated for packets that received on VRF interfaces.</p> <ul style="list-style-type: none"> <li>• Use this command to disable authentication traps only for those packets on VRF interfaces with incorrect community associations.</li> </ul> |

## Configuration Examples for SNMP Support over VPNs—Context-Based Access Control

### Example: Configuring Context-Based Access Control

The following configuration example shows how to configure the SNMP Support over VPNs—Context-Based Access Control feature for SNMPv1 or SNMPv2:



**Note** Use the **snmp context** command instead of the **context** command, depending on your release. See the *Cisco IOS Network Management Command Reference* for more information.

```

snmp-server context A
snmp-server context B
ip vrf Customer_A
  rd 100:110
  context A
  route-target export 100:1000
  route-target import 100:1000
!
ip vrf Customer_B
  rd 100:120
  context B
  route-target export 100:2000
  route-target import 100:2000
!
interface TenGigabitEthernet4/1/0
  description Belongs to VPN A
  ip vrf forwarding CustomerA
  ip address 192.168.2.1 255.255.255.0

interface TenGigabitEthernet4/1/1
  description Belongs to VPN B
  ip vrf forwarding CustomerB
  ip address 192.168.2.2 255.255.255.0
snmp-server user commA grp1A v1
snmp-server user commA grp2A v2c
snmp-server user commB grp1B v1
snmp-server user commB grp2B v2c
snmp-server group grp1A v1 context A read viewA write viewA notify viewA
snmp-server group grp1B v1 context B read viewB write viewB notify viewB
snmp-server view viewA ipForward included
snmp-server view viewA ciscoPingMIB included
snmp-server view viewB ipForward included
snmp-server view viewB ciscoPingMIB included
snmp-server enable traps
snmp-server host 192.168.2.3 vrf CustomerA commA udp-port 7002
snmp-server host 192.168.2.4 vrf CustomerB commB udp-port 7002
snmp mib community-map commA context A target-list commAvpn
! Configures source address validation
snmp mib community-map commB context B target-list commBvpn
! Configures source address validation
snmp mib target list commAvpn vrf CustomerA
! Configures a list of VRFs or from which community commA is valid
snmp mib target list commBvpn vrf CustomerB
! Configures a list of VRFs or from which community commB is valid
    
```

## Additional References

### Related Documents

| Related Topic                     | Document Title                                        |
|-----------------------------------|-------------------------------------------------------|
| Cisco Network Management commands | <i>Cisco IOS Network Management Command Reference</i> |

| Related Topic         | Document Title                                                                                |
|-----------------------|-----------------------------------------------------------------------------------------------|
| SNMP configuration    | “Configuring SNMP Support” chapter in the <i>Cisco Network Management Configuration Guide</i> |
| SNMP Support for VPNs | SNMP Notification Support for VPNs                                                            |

**Standards**

| Standard | Title |
|----------|-------|
| None     | --    |

**MIBs**

| MIB                                                                                                                                                                                  | MIBs Link                                                                                                                                                                                                                              |
|--------------------------------------------------------------------------------------------------------------------------------------------------------------------------------------|----------------------------------------------------------------------------------------------------------------------------------------------------------------------------------------------------------------------------------------|
| <ul style="list-style-type: none"> <li>• CISCO-PING-MIB</li> <li>• IP-FORWARD-MIB</li> <li>• SNMP-VACM-MIB, <i>The View-based Access Control Model (ACM) MIB for SNMP</i></li> </ul> | <p>To locate and download MIBs for selected platforms, Cisco software releases, and feature sets, use Cisco MIB Locator found at the following URL:</p> <p><a href="http://www.cisco.com/go/mibs">http://www.cisco.com/go/mibs</a></p> |

**RFCs**

| RFC      | Title                                                                                                       |
|----------|-------------------------------------------------------------------------------------------------------------|
| RFC 1441 | <i>Introduction to version 2 of the Internet-standard Network Management Framework</i>                      |
| RFC 1442 | <i>Structure of Management Information for version 2 of the Simple Network Management Protocol (SNMPv2)</i> |
| RFC 1443 | <i>Textual Conventions for version 2 of the Simple Network Management Protocol (SNMPv2)</i>                 |
| RFC 1444 | <i>Conformance Statements for version 2 of the Simple Network Management Protocol (SNMPv2)</i>              |
| RFC 1445 | <i>Administrative Model for version 2 of the Simple Network Management Protocol (SNMPv2)</i>                |
| RFC 1446 | <i>Security Protocols for version 2 of the Simple Network Management Protocol (SNMPv2)</i>                  |
| RFC 1447 | <i>Party MIB for version 2 of the Simple Network Management Protocol (SNMPv2)</i>                           |
| RFC 1448 | <i>Protocol Operations for version 2 of the Simple Network Management Protocol (SNMPv2)</i>                 |
| RFC 1449 | <i>Transport Mappings for version 2 of the Simple Network Management Protocol (SNMPv2)</i>                  |
| RFC 1450 | <i>Management Information Base for version 2 of the Simple Network Management Protocol (SNMPv2)</i>         |
| RFC 2571 | <i>An Architecture for Describing SNMP Management Frameworks</i>                                            |

| RFC      | Title                                                                                                                |
|----------|----------------------------------------------------------------------------------------------------------------------|
| RFC 2576 | <i>Coexistence between Version 1, Version 2, and Version 3 of the Internet-standard Network Management Framework</i> |

**Technical Assistance**

| Description                                                                                                                                                                                                                                                                                                                                                                          | Link                                                                                                              |
|--------------------------------------------------------------------------------------------------------------------------------------------------------------------------------------------------------------------------------------------------------------------------------------------------------------------------------------------------------------------------------------|-------------------------------------------------------------------------------------------------------------------|
| The Cisco Support and Documentation website provide online resources to download documentation, software, and tools. Use these resources to install and configure the software and to troubleshoot and resolve technical issues with Cisco products and technologies. Access to most tools on the Cisco Support and Documentation website requires a Cisco.com user ID and password. | <a href="http://www.cisco.com/cisco/web/support/index.html">http://www.cisco.com/cisco/web/support/index.html</a> |

# Feature Information for SNMP Support over VPNs—Context-Based Access Control

Use Cisco Feature Navigator to find information about the platform support and software image support. Cisco Feature Navigator enables you to determine which software images support a specific software release, feature set, or platform. To access Cisco Feature Navigator, go to the <https://cfng.cisco.com/> link. An account on the Cisco.com page is not required.



**Note** The following table lists the software release in which a given feature is introduced. Unless noted otherwise, subsequent releases of that software release train also support that feature.

*Table 346: Feature Information for SNMP Support over VPNs—Context-Based Access Control*

| Feature Name                                        | Releases                    | Feature Information                                                                                               |
|-----------------------------------------------------|-----------------------------|-------------------------------------------------------------------------------------------------------------------|
| SNMP Support over VPNs—Context-Based Access Control | Cisco IOS XE Everest 16.6.1 | This feature was integrated into Cisco IOS XE Everest 16.6.1 on the Cisco cBR Series Converged Broadband Routers. |



## CHAPTER 109

# SNMP Engine Enhancement

---

The SNMP Cache Engine Enhancement feature caches the SNMP information on the Supervisor.

Your software release may not support all the features that are documented in this module. For the latest feature information and caveats, see the release notes for your platform and software release. The Feature Information Table at the end of this document provides information about the documented features and lists the releases in which each feature is supported.

Use Cisco Feature Navigator to find information about platform support and Cisco software image support. To access Cisco Feature Navigator, go to <http://tools.cisco.com/ITDIT/CFN/>. An account on <http://www.cisco.com/> is not required.

### Contents

- [Hardware Compatibility Matrix for the Cisco cBR Series Routers, on page 1755](#)
- [Restrictions for SNMP Cache Engine Enhancement, on page 1756](#)
- [Information About SNMP Cache Engine Enhancement, on page 1757](#)
- [How to Configure SNMP Cache Engine Enhancement, on page 1757](#)
- [Verifying the SNMP Cache Engine Status, on page 1758](#)
- [Additional References, on page 1759](#)
- [Feature Information for SNMP Cache Engine Enhancement, on page 1759](#)

## Hardware Compatibility Matrix for the Cisco cBR Series Routers



---

**Note** The hardware components that are introduced in a given Cisco IOS-XE Release are supported in all subsequent releases unless otherwise specified.

---

Table 347: Hardware Compatibility Matrix for the Cisco cBR Series Routers

| Cisco CMTS Platform                    | Processor Engine                                                                                                                                                                                  | Interface Cards                                                                                                                                                                                                                                                                                                                                                                                                                                                                                                                                                                                                                                                                                                                                                                                 |
|----------------------------------------|---------------------------------------------------------------------------------------------------------------------------------------------------------------------------------------------------|-------------------------------------------------------------------------------------------------------------------------------------------------------------------------------------------------------------------------------------------------------------------------------------------------------------------------------------------------------------------------------------------------------------------------------------------------------------------------------------------------------------------------------------------------------------------------------------------------------------------------------------------------------------------------------------------------------------------------------------------------------------------------------------------------|
| Cisco cBR-8 Converged Broadband Router | <p><b>Cisco IOS-XE Release 16.5.1 and Later Releases</b></p> <p>Cisco cBR-8 Supervisor:</p> <ul style="list-style-type: none"> <li>• PID—CBR-SUP-250G</li> <li>• PID—CBR-CCAP-SUP-160G</li> </ul> | <p><b>Cisco IOS-XE Release 16.5.1 and Later Releases</b></p> <p>Cisco cBR-8 CCAP Line Cards:</p> <ul style="list-style-type: none"> <li>• PID—CBR-LC-8D30-16U30</li> <li>• PID—CBR-LC-8D31-16U30</li> <li>• PID—CBR-RF-PIC</li> <li>• PID—CBR-RF-PROT-PIC</li> <li>• PID—CBR-CCAP-LC-40G</li> <li>• PID—CBR-CCAP-LC-40G-R</li> <li>• PID—CBR-CCAP-LC-G2-R</li> <li>• PID—CBR-SUP-8X10G-PIC</li> <li>• PID—CBR-2X100G-PIC</li> </ul> <p>Digital PICs:</p> <ul style="list-style-type: none"> <li>• PID—CBR-DPIC-8X10G</li> <li>• PID—CBR-DPIC-2X100G</li> </ul> <p>Cisco cBR-8 Downstream PHY Module:</p> <ul style="list-style-type: none"> <li>• PID—CBR-D31-DS-MOD</li> </ul> <p>Cisco cBR-8 Upstream PHY Modules:</p> <ul style="list-style-type: none"> <li>• PID—CBR-D31-US-MOD</li> </ul> |



**Note** Do not use DPICs (8X10G and 2x100G) to forward IP traffic, as it may cause buffer exhaustion, leading to line card reload.

The only allowed traffic on a DPIC interface is DEPI, UEPI, and GCP traffic from the Cisco cBR-8 router to Remote PHY devices. Other traffic such as DHCP, SSH, and UTSC should flow via another router, since DPICs cannot be used for normal routing.

## Restrictions for SNMP Cache Engine Enhancement

The time interval for which the cached information is available on the Supervisor is 5 seconds.



# Information About SNMP Cache Engine Enhancement

The SNMP Cache Engine Enhancement feature caches the information on the Supervisor for the MIB tables, which need to retrieve the data from the interface cards. When a MIB table item is queried from the interface card, the next  $N$  items are retrieved and cached on the Supervisor.

For example, if SNMP client queries the docsIf3CmtsCmRegStatusMacAddr.1, the interface card bundles docsIf3CmtsCmRegStatusMacAddr.1, docsIf3CmtsCmRegStatusMacAddr.2, docsIf3CmtsCmRegStatusMacAddr.3, to docsIf3CmtsCmRegStatusMacAddr.N together in one IPC response, and sends it to the Supervisor. The Supervisor caches all the items locally. When the SNMP client queries the docsIf3CmtsCmRegStatusMacAddr.2 later, the information is available in the Supervisor cache directly instead of sending another IPC message to interface card. The number  $N$  depends on the single MIB item size and maximum IPC message buffer size.

The MIB table information for following MIBs are retrieved and cached on the Supervisor:

- DOCS-IF-MIB
- DOCS-IFEXT2-MIB
- DOCS-QOS-MIB
- DOCS-IF3-MIB
- DOCS-IF31-MIB
- DOCS-QOS3-MIB
- DOCS-IETF-QOS-MIB
- DOCS-BPI-PLUS-MIB
- DOCS-LOADBALANCING-MIB
- DOCS-LOADBAL3-MIB
- DOCS-DSG-IF-MIB
- CISCO-DOCS-EXT-MIB
- CISCO-CABLE-WIDEBAND-MIB
- CISCO-CABLE-SPECTRUM-MIB

This feature is enabled by default on the Cisco cBR routers. The time interval for which the SNMP cache information is stored on the Supervisor is known as *age* and set to 5 seconds.

## How to Configure SNMP Cache Engine Enhancement

### Before you begin

You must configure the **service internal** command in global configuration mode to enable or disable SNMP Cache Engine Enhancement.

**Procedure**

|               | Command or Action                                                                                   | Purpose                                                                                                                      |
|---------------|-----------------------------------------------------------------------------------------------------|------------------------------------------------------------------------------------------------------------------------------|
| <b>Step 1</b> | <b>enable</b><br><b>Example:</b><br>Router> <b>enable</b>                                           | Enables privileged EXEC mode.<br><ul style="list-style-type: none"><li>• Enter your password, if prompted.</li></ul>         |
| <b>Step 2</b> | <b>configure terminal</b><br><b>Example:</b><br>Router# <b>configure terminal</b>                   | Enters global configuration mode.                                                                                            |
| <b>Step 3</b> | <b>cable snmp cache active</b><br><b>Example:</b><br>Router(config)# <b>cable snmp cache active</b> | Sets the SNMP cache status to active.<br><b>Note</b> Use the <b>no</b> form of the command to disable the SNMP cache status. |
| <b>Step 4</b> | <b>exit</b><br><b>Example:</b><br>Router(config)# <b>exit</b>                                       | Exits the global configuration mode and enters the privileged EXEC mode.                                                     |

## Verifying the SNMP Cache Engine Status

Use the `show cable snmp cache-status` command to display the current SNMP cache engine status.



**Important** You must configure the `service internal` command in global configuration mode to verify the SNMP cache engine status.

Following is a sample output of the command.

```
Router# show cable snmp cache-status

Cache engine is ON, age: 5 seconds
```

Use the `test cable snmp counter-show` command to display the cache counters information.

```
Router# test cable snmp counter-show
===== cache counters =====
ubrccce_snmp_cache_hit_counter:0.
ubrccce_snmp_cache_get_from_lc_counter:1.
ubrccce_snmp_cache_miss_counter:0.
ubrccce_snmp_cache_ipc_fail_counter:0.
ubrccce_snmp_cache_buffer_full_counter:0.
```

*hit* and *mis* are the historic information for the SNMP cache after the system bootup. *hit* indicates the number of times the SNMP queries are hit in the cache and *mis* indicates the number of times the SNMP queries are missed in the SNMP cache.

# Additional References

## Technical Assistance

| Description                                                                                                                                                                                                                                                                                                                                                                                                                                                                                                                                                             | Link                                                                           |
|-------------------------------------------------------------------------------------------------------------------------------------------------------------------------------------------------------------------------------------------------------------------------------------------------------------------------------------------------------------------------------------------------------------------------------------------------------------------------------------------------------------------------------------------------------------------------|--------------------------------------------------------------------------------|
| <p>The Cisco Support website provides extensive online resources, including documentation and tools for troubleshooting and resolving technical issues with Cisco products and technologies.</p> <p>To receive security and technical information about your products, you can subscribe to various services, such as the Product Alert Tool (accessed from Field Notices), the Cisco Technical Services Newsletter, and Really Simple Syndication (RSS) Feeds.</p> <p>Access to most tools on the Cisco Support website requires a Cisco.com user ID and password.</p> | <p><a href="http://www.cisco.com/support">http://www.cisco.com/support</a></p> |

# Feature Information for SNMP Cache Engine Enhancement

Use Cisco Feature Navigator to find information about the platform support and software image support. Cisco Feature Navigator enables you to determine which software images support a specific software release, feature set, or platform. To access Cisco Feature Navigator, go to the <https://cfmg.cisco.com/> link. An account on the Cisco.com page is not required.



**Note** The following table lists the software release in which a given feature is introduced. Unless noted otherwise, subsequent releases of that software release train also support that feature.

*Table 348: Feature Information for SNMP Cache Engine Enhancement*

| Feature Name                  | Releases                    | Feature Information                                                                                               |
|-------------------------------|-----------------------------|-------------------------------------------------------------------------------------------------------------------|
| SNMP Cache Engine Enhancement | Cisco IOS XE Everest 16.6.1 | This feature was integrated into Cisco IOS XE Everest 16.6.1 on the Cisco cBR Series Converged Broadband Routers. |





## CHAPTER 110

# Onboard Failure Logging

Onboard Failure Logging (OBFL) captures and stores hardware failure and environmental information into nonvolatile memory. OBFL permits improved accuracy in hardware troubleshooting and root cause isolation analysis. Stored OBFL data can be retrieved in the event of a router crash or failure.

- [Finding Feature Information, on page 1761](#)
- [Hardware Compatibility Matrix for the Cisco cBR Series Routers, on page 1761](#)
- [Understanding OBFL, on page 1763](#)
- [Configuring OBFL, on page 1763](#)
- [Displaying OBFL Logging Information, on page 1763](#)
- [Clearing OBFL Logging, on page 1764](#)
- [Configuration and Verification Examples, on page 1764](#)
- [Feature Information for Onboard Failure Logging, on page 1770](#)

## Finding Feature Information

Your software release may not support all the features that are documented in this module. For the latest feature information and caveats, see the release notes for your platform and software release. The Feature Information Table at the end of this document provides information about the documented features and lists the releases in which each feature is supported.

Use Cisco Feature Navigator to find information about platform support and Cisco software image support. To access Cisco Feature Navigator, go to <http://tools.cisco.com/ITDIT/CFN/>. An account on <http://www.cisco.com/> is not required.

## Hardware Compatibility Matrix for the Cisco cBR Series Routers



**Note** The hardware components that are introduced in a given Cisco IOS-XE Release are supported in all subsequent releases unless otherwise specified.

Table 349: Hardware Compatibility Matrix for the Cisco cBR Series Routers

| Cisco CMTS Platform                    | Processor Engine                                                                                                                                                                                  | Interface Cards                                                                                                                                                                                                                                                                                                                                                                                                                                                                                                                                                                                                                                                                                                                                                                                 |
|----------------------------------------|---------------------------------------------------------------------------------------------------------------------------------------------------------------------------------------------------|-------------------------------------------------------------------------------------------------------------------------------------------------------------------------------------------------------------------------------------------------------------------------------------------------------------------------------------------------------------------------------------------------------------------------------------------------------------------------------------------------------------------------------------------------------------------------------------------------------------------------------------------------------------------------------------------------------------------------------------------------------------------------------------------------|
| Cisco cBR-8 Converged Broadband Router | <p><b>Cisco IOS-XE Release 16.5.1 and Later Releases</b></p> <p>Cisco cBR-8 Supervisor:</p> <ul style="list-style-type: none"> <li>• PID—CBR-SUP-250G</li> <li>• PID—CBR-CCAP-SUP-160G</li> </ul> | <p><b>Cisco IOS-XE Release 16.5.1 and Later Releases</b></p> <p>Cisco cBR-8 CCAP Line Cards:</p> <ul style="list-style-type: none"> <li>• PID—CBR-LC-8D30-16U30</li> <li>• PID—CBR-LC-8D31-16U30</li> <li>• PID—CBR-RF-PIC</li> <li>• PID—CBR-RF-PROT-PIC</li> <li>• PID—CBR-CCAP-LC-40G</li> <li>• PID—CBR-CCAP-LC-40G-R</li> <li>• PID—CBR-CCAP-LC-G2-R</li> <li>• PID—CBR-SUP-8X10G-PIC</li> <li>• PID—CBR-2X100G-PIC</li> </ul> <p>Digital PICs:</p> <ul style="list-style-type: none"> <li>• PID—CBR-DPIC-8X10G</li> <li>• PID—CBR-DPIC-2X100G</li> </ul> <p>Cisco cBR-8 Downstream PHY Module:</p> <ul style="list-style-type: none"> <li>• PID—CBR-D31-DS-MOD</li> </ul> <p>Cisco cBR-8 Upstream PHY Modules:</p> <ul style="list-style-type: none"> <li>• PID—CBR-D31-US-MOD</li> </ul> |



**Note** Do not use DPICs (8X10G and 2x100G) to forward IP traffic, as it may cause buffer exhaustion, leading to line card reload.

The only allowed traffic on a DPIC interface is DEPI, UEPI, and GCP traffic from the Cisco cBR-8 router to Remote PHY devices. Other traffic such as DHCP, SSH, and UTSC should flow via another router, since DPICs cannot be used for normal routing.

## Understanding OBFL

OBFL provides a mechanism to store hardware, software, and environment related critical data in a non-volatile memory, such as flash EPROM or EEPROM on routers. The logging information is used by the TAC team to troubleshoot and fix hardware issues.

OBFL collects data like temperatures and voltages. It stores the data in a dedicated area of the flash memory of the router. This data is retrieved by TAC personnel to troubleshoot routers. It can also be analyzed by back-end software to detect failure patterns, and possibly to recommend specific quality improvements.

### Retrieval of the OBFL message

If the hardware is defective and the system cannot boot up, any data in flash is inaccessible. In that case, use any one of the following methods to recover OBFL data:

- Read the flash through JTAG: this requires provisions in hardware design and back-end hardware and software support tools.
- Repair the system; boot it; use the OBFL CLI commands.

## Configuring OBFL

Use the **hw-module** `{all|slot|module} {slotnumber/subslotnumber|modulenum}` **logging onboard** `{disable | enable}` command to enable or disable OBFL on a specified hardware module.



---

**Note** OBFL is enabled by default.

---

```
Router# hw-module slot R0 logging onboard enable
```

## Displaying OBFL Logging Information

Use the **show logging onboard** `{slot|module|bay} {slotnumber/subslotnumber|modulenum}` `{dram | message | serdes | status | temperature | uptime | voltage | firmware}` command to view the OBFL log information.



---

**Note** OBFL is enabled by default on the Cisco cBR series router.

---

For the card PICs, use the **show logging onboard bay** `slotnumber/subslotnumber` `{dram | message | serdes | status | temperature | uptime | voltage | firmware}` command to view its OBFL information.

## Clearing OBFL Logging

Use the **clear logging onboard** `{slot|module|bay} {slotnumber/subslotnumber|modulenum}` `{dram | message | serdes | temperature | voltage|firmware}` command to clear OBFL logging.

The following example shows how to clear firmware version:

```
Router# clear logging onboard slot R0 firmware
Router# clear logging onboard bay 4/4 firmware
```

Following example shows how to clear DRAM ECC error log:

```
Router# clear logging onboard slot R0 dram
```

Following example shows how to clear OBFL error message:

```
Router# clear logging onboard slot R0 message
```

Following example shows how to clear onboard serdes log:

```
Router# clear logging onboard slot R0 serdes
```

Following example shows how to clear onboard temperature log:

```
Router# clear logging onboard slot R0 temperature
```

Following example shows how to clear onboard voltage log:

```
Router# clear logging onboard slot R0 voltage
```

## Configuration and Verification Examples

### Example—Verifying OBFL Configuration Status

```
Router#show logging onboard slot R1 status
Status: Enabled

Router#show logging onboard slot 5 status
Status: Disabled
```

### Example—Displaying OBFL Logs

The following onboard failure logging example shows firmware version for SUP160:

```
Router# show logging onboard slot R0 firmware
```

| slot | timestamp         | firmware      | version   |
|------|-------------------|---------------|-----------|
| 0    | 01/16/18 09:36:38 | CPLD          | 16052011  |
| 0    | 01/16/18 09:36:38 | ViperSO CPLD  | 14091201  |
| 0    | 01/16/18 09:36:38 | ViperSIO CPLD | 14092901  |
| 0    | 01/16/18 09:36:39 | Rommon        | 16.6(1r)S |



```

0    01/16/18 09:36:39    SUP-DC CPLD                ffffffff
0    01/16/18 09:36:39    SUP PSOC 0                  v4.1.0_i2c1
0    01/16/18 09:36:39    SUP PSOC 1                  v4.0.8_i2c1
0    01/16/18 09:36:39    SUP PSOC 2                  v4.1.1_IVB
0    01/16/18 09:36:39    SUP PSOC 3                  v4.0.6_i2c1
0    01/16/18 09:36:39    SUP-DC PSOC 0               N/A
0    01/16/18 09:36:39    SUP-DC PSOC 1               N/A
0    01/16/18 09:36:39    SUP-PIC PSOC 0              V2.0.6
0    01/16/18 09:36:39    SUP-PIC PSOC 1              V2.0.6
0    01/16/18 09:36:39    Blackbird                   00000112
0    01/16/18 09:38:12    Raptor ESI                   0001003b
    
```

The following onboard failure logging example shows firmware version for linecards:  
 Router# **show logging onboard slot 3 firmware**

| slot | timestamp         | firmware     | version    |
|------|-------------------|--------------|------------|
| 3    | 01/16/18 09:41:43 | CPLD         | 00000025   |
| 3    | 01/16/18 09:41:43 | Rommon       | 2011.03.18 |
| 3    | 01/16/18 09:41:43 | Basestar     | 00110022   |
| 3    | 01/16/18 09:41:43 | Raider       | 02020018   |
| 3    | 01/16/18 09:41:43 | Caprica      | 00000023   |
| 3    | 01/16/18 09:41:43 | HA-PLL       | N/A        |
| 3    | 01/16/18 09:41:43 | PSOC 0       | v4.6       |
| 3    | 01/16/18 09:41:44 | PSOC 1       | v4.6       |
| 3    | 01/16/18 09:42:04 | dsphy0_fpga  | 2.f        |
| 3    | 01/16/18 09:42:04 | dsphy0_micro | 1.e        |
| 3    | 01/16/18 09:42:04 | dsphy0_psoc  | 3.9        |
| 3    | 01/16/18 09:42:04 | dsphy0_cp1d  | 0.6        |
| 3    | 01/16/18 09:42:04 | dsphy1_fpga  | 2.f        |
| 3    | 01/16/18 09:42:04 | dsphy1_micro | 1.e        |
| 3    | 01/16/18 09:42:04 | dsphy1_psoc  | 3.9        |
| 3    | 01/16/18 09:42:04 | dsphy1_cp1d  | 0.6        |

The following onboard failure logging example shows firmware version for RF-PICs:  
 Router# **show logging onboard bay 4/3 firmware**

| slot | timestamp         | firmware        | version  |
|------|-------------------|-----------------|----------|
| 3    | 01/16/18 09:39:21 | RF-PIC Firmware | 0000073e |

The following onboard failure logging example shows firmware version for SUP160-PIC:  
 Router# **show logging onboard bay 4/4 firmware**

| slot | timestamp         | firmware        | version      |
|------|-------------------|-----------------|--------------|
| 4    | 01/16/18 09:40:20 | SUP-PIC CPLD    | 14071504     |
| 4    | 01/16/18 09:40:20 | DTI Client FPGA | 00000005     |
| 4    | 01/16/18 09:40:20 | DTI Firmware    | 00000a03     |
| 4    | 01/16/18 09:40:20 | Raptor MAC      | 00010031     |
| 4    | 01/16/18 09:40:20 | Cortina PHY     | 201402061607 |

The following onboard failure logging example shows firmware version for D-PIC:  
 Router# **show logging onboard bay 4/8 firmware**

| slot | timestamp         | firmware      | version                                        |
|------|-------------------|---------------|------------------------------------------------|
| 8    | 01/16/18 09:40:13 | DPIC Firmware | 00010001 (UBOOT:2015.7 FPGA:00fd0000 00010011) |

The following onboard failure logging example shows the firmware versions that recently booted up:

Router# **show logging onboard slot R0 firmware reverse**

| slot | timestamp         | firmware       | version     |
|------|-------------------|----------------|-------------|
| 0    | 01/16/18 09:38:12 | Raptor ESI     | 0001003b    |
| 0    | 01/16/18 09:36:39 | Blackbird      | 00000112    |
| 0    | 01/16/18 09:36:39 | SUP-PIC PSOC 1 | V2.0.6      |
| 0    | 01/16/18 09:36:39 | SUP-PIC PSOC 0 | V2.0.6      |
| 0    | 01/16/18 09:36:39 | SUP-DC PSOC 1  | N/A         |
| 0    | 01/16/18 09:36:39 | SUP-DC PSOC 0  | N/A         |
| 0    | 01/16/18 09:36:39 | SUP PSOC 3     | v4.0.6_i2c1 |
| 0    | 01/16/18 09:36:39 | SUP PSOC 2     | v4.1.1_IVB  |
| 0    | 01/16/18 09:36:39 | SUP PSOC 1     | v4.0.8_i2c1 |

```

0    01/16/18 09:36:39    SUP PSOC 0                v4.1.0_i2c1
0    01/16/18 09:36:39    SUP-DC CPLD                ffffffff
0    01/16/18 09:36:39    Rommon                      16.6(1r)S
0    01/16/18 09:36:38    ViperSIO CPLD              14092901
0    01/16/18 09:36:38    ViperSO CPLD               14091201
0    01/16/18 09:36:38    CPLD                       16052011
    
```

The following onboard failure logging example shows the firmware versions that are logged in the backup log file. The backup log file is created when an existing log file reaches its maximum size of 1MB.

sj-104-cbr-13#show logging onboard bay 4/4 firmware backup

```

slot    timestamp                firmware                    version
-----
4    01/16/18 09:40:20    SUP-PIC CPLD                14071504
4    01/16/18 09:40:20    DTI Client FPGA             00000005
4    01/16/18 09:40:20    DTI Firmware                 00000a03
4    01/16/18 09:40:20    Raptor MAC                   00010031
4    01/16/18 09:40:20    Cortina PHY                  201402061607
...
4    01/17/18 08:38:22    SUP-PIC CPLD                14071504
4    01/17/18 08:38:22    DTI Client FPGA             00000005
4    01/17/18 08:38:22    DTI Firmware                 00000a03
4    01/17/18 08:38:22    Raptor MAC                   00010031
4    01/17/18 08:38:22    Cortina PHY                  201402061607
    
```

The following onboard failure logging example shows the firmware versions that were recently logged in the backup log file:

Router# **show logging onboard bay 4/4 firmware backup reverse**

```

slot    timestamp                firmware                    version
-----
4    01/17/18 08:38:22    Cortina PHY                  201402061607
4    01/17/18 08:38:22    Raptor MAC                   00010031
4    01/17/18 08:38:22    DTI Firmware                 00000a03
4    01/17/18 08:38:22    DTI Client FPGA             00000005
4    01/17/18 08:38:22    SUP-PIC CPLD                14071504
...
4    01/16/18 09:40:20    Cortina PHY                  201402061607
4    01/16/18 09:40:20    Raptor MAC                   00010031
4    01/16/18 09:40:20    DTI Firmware                 00000a03
    
```

```

4    01/16/18 09:40:20    DTI Client FPGA                00000005
4    01/16/18 09:40:20    SUP-PIC CPLD                    14071504
    
```

```

Router#show logging onboard slot R1 message
timestamp          module      sev  message
    
```

```

-----
01/01/12 12:00:23    SUP_PSOC  3    SUP MB PSOC alert interrupt
01/01/12 12:00:23    SUP_PSOC  3    SUP MB PSOC alert interrupt
01/01/12 12:00:23    SUP_PSOC  3    SUP MB PSOC alert interrupt
01/01/12 12:00:23    SUP_PSOC  3    SUP MB PSOC alert interrupt
01/01/12 12:01:15    SUP_PSOC  3    SUP MB PSOC alert interrupt
    
```

```

Router#show logging onboard slot R1 voltage
    
```

| Name            | Id | Data (mV) | Poll | Last Update       |
|-----------------|----|-----------|------|-------------------|
| PSOC-MB2_20: VO | 40 | 1791      | 1    | 01/01/12 17:03:03 |
| PSOC-MB2_21: VO | 41 | 3290      | 1    | 01/01/12 17:03:03 |
| PSOC-MB2_22: VO | 42 | 3293      | 1    | 01/01/12 17:03:03 |
| PSOC-MB2_23: VO | 43 | 3299      | 1    | 01/01/12 17:03:03 |
| PSOC-MB2_24: VO | 44 | 4958      | 1    | 01/01/12 17:03:03 |
| PSOC-MB2_25: VO | 45 | 4508      | 1    | 01/01/12 17:03:03 |
| PSOC-MB3_0: VOU | 46 | 4999      | 1    | 01/01/12 17:03:03 |
| PSOC-MB3_1: VOU | 47 | 4982      | 1    | 01/01/12 17:03:03 |
| PSOC-MB3_2: VOU | 48 | 1499      | 1    | 01/01/12 17:03:03 |
| PSOC-MB3_3: VOU | 49 | 1193      | 1    | 01/01/12 17:03:03 |
| PSOC-MB3_4: VOU | 50 | 708       | 1    | 01/01/12 17:03:03 |
| PSOC-MB3_5: VOU | 51 | 757       | 1    | 01/01/12 17:03:03 |
| PSOC-MB3_6: VOU | 52 | 585       | 1    | 01/01/12 17:03:03 |
| PSOC-MB3_7: VOU | 53 | 1501      | 1    | 01/01/12 17:03:03 |

```

Router#show logging onboard slot R1 temperature
    
```

| Name           | Id  | Data (C) | Poll | Last Update       |
|----------------|-----|----------|------|-------------------|
| Temp: BB_DIE   | 159 | 25       | 1    | 01/02/12 23:04:19 |
| Temp: VP_DIE   | 160 | 21       | 1    | 01/02/12 23:04:19 |
| Temp: RT-E_DIE | 161 | 29       | 1    | 01/02/12 23:04:19 |
| Temp: INLET_1  | 162 | 20       | 1    | 01/02/12 23:04:19 |
| Temp: INLET_2  | 163 | 18       | 1    | 01/02/12 23:04:19 |
| Temp: OUTLET_1 | 164 | 22       | 1    | 01/02/12 23:04:19 |
| Temp: 3882_1   | 165 | 44       | 1    | 01/02/12 23:04:19 |
| Temp: 3882_1A  | 166 | 38       | 1    | 01/02/12 23:04:19 |
| Temp: 3882_1B  | 167 | 36       | 1    | 01/02/12 23:04:19 |
| Temp: 3882_2   | 168 | 38       | 1    | 01/02/12 23:04:19 |
| Temp: 3882_2A  | 169 | 37       | 1    | 01/02/12 23:04:19 |
| Temp: 3882_2B  | 170 | 35       | 1    | 01/02/12 23:04:19 |
| Temp: 3882_3   | 171 | 38       | 1    | 01/02/12 23:04:19 |

```

Router#show logging onboard slot R1 uptime latest
    
```

| Slot | Reset reason         | Power On          |
|------|----------------------|-------------------|
| 1    | reset local software | 01/02/12 23:02:46 |

```
Router#show logging onboard slot R1 uptime
Slot      Reset reason  Power On
-----
0         reset local software  01/06/12 01:52:26
4         reset local software  01/06/12 01:52:42
0         reset local software  01/06/12 01:52:45
0         reset local software  01/06/12 02:20:27
4         reset local software  01/06/12 02:20:43
0         reset local software  01/06/12 02:20:46
0         reset local software  01/06/12 05:12:02
4         reset local software  01/06/12 05:12:19
0         reset local software  01/06/12 05:12:22
0         reset local software  01/06/12 05:17:31
4         reset local software  01/06/12 05:17:48
0         reset local software  01/06/12 05:17:51
0         reset power on      01/01/12 08:56:44
4         reset power on      01/01/12 08:57:00
```

```
Router# show logging onboard slot R1 uptime detail
-----
UPTIME SUMMARY INFORMATION
-----
First customer power on: 01/15/18 17:33:12
Number of resets: 6
Number of slot changes: 0
Last reset reason: power reset from RP
Current slot: 2
Current power on: 01/17/18 16:14:59
```

```
-----
UPTIME CONTINUOUS INFORMATION
-----
Slot      Reset reason  Power On      Up: Years  Days  Hours  Mins
-----
2         power reset from RP  01/15/18 17:33:12  0      0      0      0
2         power reset from RP  01/16/18 11:44:28  0      0      18     0
2         power reset from RP  01/16/18 12:13:19  0      0      0      15
2         power reset from RP  01/16/18 17:12:43  0      0      4      0
2         power reset from RP  01/17/18 14:34:36  0      0      21     0
2         power reset from RP  01/17/18 16:14:59  0      0      1      0
```

```
Router#show logging onboard bay 4/3 message
timestamp      module      sev  message
-----
01/02/12 08:14:22  RFSW-PIC  6    CAT1836E07Q:7.13:Initialize:3/1
01/02/12 08:20:42  RFSW-PIC  6    CAT1836E07Q:7.13:Initialize:3/1
01/02/12 09:13:23  RFSW-PIC  6    CAT1836E07Q:7.13:Initialize:3/1
01/02/12 09:42:33  RFSW-PIC  6    CAT1836E07Q:7.13:Initialize:3/1
01/02/12 11:56:09  RFSW-PIC  6    CAT1836E07Q:7.13:Initialize:3/1
01/02/12 12:27:23  RFSW-PIC  6    CAT1836E07Q:7.13:Initialize:3/1
```

```
Router#show logging onboard bay 5/3 message
timestamp          module      sev  message
-----
01/22/15 01:06:05  RFSW-PIC  6    JAB092709EL:7.35:Init--stby:3/1
01/22/15 01:19:01  RFSW-PIC  6    JAB092709EL:7.35:Init--stby:3/1
01/22/15 01:31:47  RFSW-PIC  6    JAB092709EL:7.35:Init--stby:3/1
01/22/15 01:44:38  RFSW-PIC  6    JAB092709EL:7.35:Init--stby:3/1
01/22/15 01:59:04  RFSW-PIC  6    JAB092709EL:7.35:Init--stby:3/1
01/22/15 02:12:07  RFSW-PIC  6    JAB092709EL:7.35:Init--stby:3/1
```

```
Router#show logging onboard bay 4/4 message
timestamp          module      sev  message
-----
01/01/12 10:01:44  SUP-PIC   0    TEST1122334:0.130:PLL-LOS:1[04]
01/01/12 10:01:45  SUP-PIC   0    TEST1122334:0.130:PLL-LOS:2[04]
01/01/12 10:01:46  SUP-PIC   0    TEST1122334:0.130:PLL-LOS:3[04]
01/01/12 10:01:49  SUP-PIC   0    TEST1122334:0.130:PLL-LOS:4[04]
01/01/12 10:01:50  SUP-PIC   0    TEST1122334:0.130:PLL-LOS:5[04]
01/01/12 10:01:51  SUP-PIC   0    TEST1122334:0.130:PLL-LOS:6[04]
```

```
Router#show logging onboard bay 5/5 message
timestamp          module      sev  message
-----
01/03/12 13:52:55  SUP-PIC   0    TEST8877665:0.130:PLL-LOS:1[04]
01/03/12 13:52:56  SUP-PIC   0    TEST8877665:0.130:PLL-LOS:2[04]
01/03/12 13:52:57  SUP-PIC   0    TEST8877665:0.130:PLL-LOS:3[04]
01/03/12 13:53:00  SUP-PIC   0    TEST8877665:0.130:PLL-LOS:4[04]
01/03/12 13:53:01  SUP-PIC   0    TEST8877665:0.130:PLL-LOS:5[04]
```

## Feature Information for Onboard Failure Logging

Use Cisco Feature Navigator to find information about the platform support and software image support. Cisco Feature Navigator enables you to determine which software images support a specific software release, feature set, or platform. To access Cisco Feature Navigator, go to the <https://cfnng.cisco.com/> link. An account on the Cisco.com page is not required.



**Note** The following table lists the software release in which a given feature is introduced. Unless noted otherwise, subsequent releases of that software release train also support that feature.

*Table 350: Feature Information for Onboard Failure Logging*

| Feature Name            | Releases                    | Feature Information                                                                                               |
|-------------------------|-----------------------------|-------------------------------------------------------------------------------------------------------------------|
| Onboard Failure Logging | Cisco IOS XE Everest 16.6.1 | This feature was integrated into Cisco IOS XE Everest 16.6.1 on the Cisco cBR Series Converged Broadband Routers. |







## CHAPTER 111

# Control Point Discovery

---

This document describes the Control Point Discovery (CPD) feature. This feature, along with Network Layer Signaling (NLS), enables automatic discovery of any control point associated with an end point.

Your software release may not support all the features that are documented in this module. For the latest feature information and caveats, see the release notes for your platform and software release. The Feature Information Table at the end of this document provides information about the documented features and lists the releases in which each feature is supported.

Use Cisco Feature Navigator to find information about platform support and Cisco software image support. To access Cisco Feature Navigator, go to <http://tools.cisco.com/ITDIT/CFN/>. An account on <http://www.cisco.com/> is not required.

### Contents

- [Hardware Compatibility Matrix for the Cisco cBR Series Routers, on page 1773](#)
- [Prerequisites for Control Point Discovery, on page 1774](#)
- [Restrictions for Control Point Discovery, on page 1775](#)
- [Information About Control Point Discovery, on page 1775](#)
- [How to Configure CPD, on page 1777](#)
- [Additional References, on page 1782](#)
- [Feature Information for Control Point Discovery, on page 1782](#)

## Hardware Compatibility Matrix for the Cisco cBR Series Routers



---

**Note** The hardware components that are introduced in a given Cisco IOS-XE Release are supported in all subsequent releases unless otherwise specified.

---

Table 351: Hardware Compatibility Matrix for the Cisco cBR Series Routers

| Cisco CMTS Platform                    | Processor Engine                                                                                                                                                                                  | Interface Cards                                                                                                                                                                                                                                                                                                                                                                                                                                                                                                                                                                                                                                                                                                                                                                                 |
|----------------------------------------|---------------------------------------------------------------------------------------------------------------------------------------------------------------------------------------------------|-------------------------------------------------------------------------------------------------------------------------------------------------------------------------------------------------------------------------------------------------------------------------------------------------------------------------------------------------------------------------------------------------------------------------------------------------------------------------------------------------------------------------------------------------------------------------------------------------------------------------------------------------------------------------------------------------------------------------------------------------------------------------------------------------|
| Cisco cBR-8 Converged Broadband Router | <p><b>Cisco IOS-XE Release 16.5.1 and Later Releases</b></p> <p>Cisco cBR-8 Supervisor:</p> <ul style="list-style-type: none"> <li>• PID—CBR-SUP-250G</li> <li>• PID—CBR-CCAP-SUP-160G</li> </ul> | <p><b>Cisco IOS-XE Release 16.5.1 and Later Releases</b></p> <p>Cisco cBR-8 CCAP Line Cards:</p> <ul style="list-style-type: none"> <li>• PID—CBR-LC-8D30-16U30</li> <li>• PID—CBR-LC-8D31-16U30</li> <li>• PID—CBR-RF-PIC</li> <li>• PID—CBR-RF-PROT-PIC</li> <li>• PID—CBR-CCAP-LC-40G</li> <li>• PID—CBR-CCAP-LC-40G-R</li> <li>• PID—CBR-CCAP-LC-G2-R</li> <li>• PID—CBR-SUP-8X10G-PIC</li> <li>• PID—CBR-2X100G-PIC</li> </ul> <p>Digital PICs:</p> <ul style="list-style-type: none"> <li>• PID—CBR-DPIC-8X10G</li> <li>• PID—CBR-DPIC-2X100G</li> </ul> <p>Cisco cBR-8 Downstream PHY Module:</p> <ul style="list-style-type: none"> <li>• PID—CBR-D31-DS-MOD</li> </ul> <p>Cisco cBR-8 Upstream PHY Modules:</p> <ul style="list-style-type: none"> <li>• PID—CBR-D31-US-MOD</li> </ul> |



**Note** Do not use DPICs (8X10G and 2x100G) to forward IP traffic, as it may cause buffer exhaustion, leading to line card reload.

The only allowed traffic on a DPIC interface is DEPI, UEPI, and GCP traffic from the Cisco cBR-8 router to Remote PHY devices. Other traffic such as DHCP, SSH, and UTSC should flow via another router, since DPICs cannot be used for normal routing.

## Prerequisites for Control Point Discovery

No special equipment or software is needed to use the Control Point Discovery feature.

## Restrictions for Control Point Discovery

- The CPD feature does not sync any dynamic CPD/NLS related data between the route processors (RPs). After sending a NLS challenge to the controller, the new active PRE will ignore the NLS response as a result of any RP switchover.
- The CPEs become inaccessible for a small duration during line card switchovers. During this interval, any CPD request received on CMTS will be responded to as if the endpoint is not connected or as if the control relationship is not supported.
- The CPD functionality is restricted to default VPN table id (0).
- Only manual configuration of NLS authentication pass phrase would be supported for CPD/NLS security.
- For NLS authentication, HMAC SHA1 (no configuration option) is used with MAC length truncated to 96 bits.

## Information About Control Point Discovery

To configure the Control Point Discovery feature, you should understand the following concepts:

### Control Points

Control points are points in a network that can be used to apply certain functions and controls for a media stream. In a cable environment, the control points are Cable Modem Termination Systems (CMTS) and devices that utilizes these control points are referred to as CPD Requestors (or controllers).

Cable CPD Requestors include the following:

- Call Management Server (CMS)
- Policy Server (PS)
- Mediation Device for Lawful Intercept (MD)

### Network Layer Signaling (NLS)

Network Layer Signaling (NLS) is an on-path request protocol used to carry topology discovery and other requests in support of various applications. In the CPD feature, NLS is used to transport CPD messages.

#### NLS for CPD

NLS is used to transport CPD messages. The CPD data is carried under an application payload of the NLS and contains a NLS header with flow id. The NLS flow id is used during NLS authentication to uniquely identify the CPD requests and responses for an end point of interest.

#### NLS Flags

All NLS headers contain bitwise flags. The CMTS expects the following NLS flag settings for CPD applications:

- HOP-BY-HOP = 0
- BUILD-ROUTE = 0
- TEARDOWN = 0
- BIDIRECTOINAL = 0

- AX\_CHALLENGE = 0/1
- AX\_RESPONSE = 0/1



---

**Note** Any requests with flags other than AX flags, set to one will be rejected with an error indicating a poorly formed message.

---

## NLS TLVs

The following NLS TLVs are supported for all CPD applications:

- APPLICATION\_PAYLOAD
- IPV4\_ERROR\_CODE
- IPV6\_ERROR\_CODE
- AGID
- A\_CHALLENGE
- A\_RESPONSE
- B\_CHALLENGE
- B\_RESPONSE
- AUTHENTICATION
- ECHO

The following NLS TLVs are not supported for CPD applications:

- NAT\_ADDRESS
- TIMEOUT
- IPV4\_HOP
- IPV6\_HOP

## Control Point Discovery

The control point discovery feature allows CPD Requestors to determine the control point IP address between the CPD Requestor and the media endpoint.

Using Networking Layer Signaling (NLS), the control point discovery feature sends a CPD message towards the end point (MTA). The edge/aggregation device (CMTS), located between the requestor and the endpoint, will respond to the message with its IP address.



---

**Note** For Lawful Intercept, it is important that the endpoint does not receive the CPD message. In this instance, the CMTS responds to the message without forwarding it to its destination.

---

## CPD Protocol Hierarchy

CPD messages are sent over the NLS.

The CPD Protocol Hierarchy is as follows:

1. CPD
2. NLS

- 3. UDP
- 4. IP



**Note** Since NLS is implemented on the UDP protocol, there is a potential of message loss. If messages are lost, the controller will re-send the CPD request in any such event.

## Control Relationship

A control relationship between a control point and a controller is identified as a function on a media flow that passes through a control point. A control relationship is uniquely defined by a control relationship type (CR TYPE) and control relationship ID (CR ID). The CR ID is provisioned on CMTS as well as the controller.

The table lists the supported CR TYPEs and corresponding pre-defined CR IDs

**Table 352: Supported Control Relationship Types and Corresponding Control Relationship IDs**

| Control Relationship Type      | Pre-Defined Corresponding Control Relationship ID                  |
|--------------------------------|--------------------------------------------------------------------|
| CR TYPE = 1 (Lawful Intercept) | CR ID = 1: CMTS                                                    |
|                                | CR ID = 2: Aggregation router or switch in front of CMTS           |
|                                | CR ID = 3: Aggregation router or switch in front of Media Services |
|                                | CR ID = 4: Media Gateway                                           |
|                                | CR ID = 5: Conference Server                                       |
|                                | CR ID = 6: Other                                                   |
| CR TYPE = 2 (DQoS)             | CR ID = 1: CMTS                                                    |
| CR TYPE = 3 (PCMM)             | CR ID = 1: CMTS                                                    |

## How to Configure CPD

### Enabling CPD Functionality

To enable the CPD functionality, use the cpd command in global configuration mode. The CPD message authentication is determined by NLS configuration.

**Before you begin**

The CPD message authentication is determined by NLS configuration.

**Procedure**

|               | Command or Action                                                                     | Purpose                                                                                                                                      |
|---------------|---------------------------------------------------------------------------------------|----------------------------------------------------------------------------------------------------------------------------------------------|
| <b>Step 1</b> | <b>enable</b><br><b>Example:</b><br><pre>Router&gt; enable</pre>                      | Enables privileged EXEC mode. <ul style="list-style-type: none"> <li>• Enter your password if prompted.</li> </ul>                           |
| <b>Step 2</b> | <b>configure terminal</b><br><b>Example:</b><br><pre>Router# configure terminal</pre> | Enters global configuration mode.                                                                                                            |
| <b>Step 3</b> | <b>cpd</b><br><b>Example:</b><br><pre>Router (config)# cpd</pre>                      | Enables CPD functionality <ul style="list-style-type: none"> <li>• Us the “no” form of this command to disable CPD functionality.</li> </ul> |
| <b>Step 4</b> | <b>end</b><br><b>Example:</b><br><pre>Router# end</pre>                               | Exits global configuration mode and enters privileged EXEC mode.                                                                             |

**Examples for CPD Enable**

The following example shows the cpd enabled on a router:

```
Router (config)# cpd
```

**Debugging CPD Functionality**

To debug the CPD feature, use the **debug cpd** command in privileged EXEC mode. To disable debugging, use the **no** form of this command.

**Configuring Control Relationship Identifier**

To configure a Control relationship identifier (CR ID) for CMTS, use the **cpd cr-id** command. When CPD request comes with a wild-card CR ID, the CMTS will respond with this configured value.

**Procedure**

|               | Command or Action                | Purpose                                                                                                            |
|---------------|----------------------------------|--------------------------------------------------------------------------------------------------------------------|
| <b>Step 1</b> | <b>enable</b><br><b>Example:</b> | Enables privileged EXEC mode. <ul style="list-style-type: none"> <li>• Enter your password if prompted.</li> </ul> |

|               | Command or Action                                                          | Purpose                                                          |
|---------------|----------------------------------------------------------------------------|------------------------------------------------------------------|
|               | Router> enable                                                             |                                                                  |
| <b>Step 2</b> | <b>configure terminal</b><br><b>Example:</b><br>Router# configure terminal | Enters global configuration mode.                                |
| <b>Step 3</b> | <b>cpd cr-id</b><br><b>Example:</b><br>Router (config)# cpd cr-id 100      | Configures a control relationship identifier (CR ID) for CMTS.   |
| <b>Step 4</b> | <b>end</b><br><b>Example:</b><br>Router# end                               | Exits global configuration mode and enters privileged EXEC mode. |

## Examples

The following example shows the cpd cr-id command configured with a cr-id number of 100 on a router.

```
Router (config)# cpd cr-id 100
```

## Enabling NLS Functionality

To enable the NLS functionality, use the nls command in global configuration mode. It is recommended that NLS message authentication be enabled at all times.

### Procedure

|               | Command or Action                                                          | Purpose                                                                                                            |
|---------------|----------------------------------------------------------------------------|--------------------------------------------------------------------------------------------------------------------|
| <b>Step 1</b> | <b>enable</b><br><b>Example:</b><br>Router> enable                         | Enables privileged EXEC mode. <ul style="list-style-type: none"> <li>• Enter your password if prompted.</li> </ul> |
| <b>Step 2</b> | <b>configure terminal</b><br><b>Example:</b><br>Router# configure terminal | Enters global configuration mode.                                                                                  |

|               | Command or Action                                     | Purpose                                                                                                                                                                                              |
|---------------|-------------------------------------------------------|------------------------------------------------------------------------------------------------------------------------------------------------------------------------------------------------------|
| <b>Step 3</b> | <b>nls</b><br><b>Example:</b><br>Router (config)# nls | Enables NLS functionality. <ul style="list-style-type: none"> <li>• NLS authentication is optional.</li> <li>• It is recommended that NLS message authentication be enabled at all times.</li> </ul> |
| <b>Step 4</b> | <b>end</b><br><b>Example:</b><br>Router# end          | Exits global configuration mode and enters privileged EXEC mode.                                                                                                                                     |

## Examples

The following example shows the nls command enabled on a router.

```
Router (config)# nls
```

## Debugging NLS Functionality

To debug the NLS feature, use the **debug nls** command in privileged EXEC mode. To disable debugging, use the **no** form of this command.

## Configuring Authorization Group Identifier and Authentication Key

The Authorization Group Identifier (AG ID) and corresponding authorization key are provisioned on CMTS, as well as on controller/CPD requester.

To configure the Authorization Group Identifier and Authentication Key, use the nls ag-id command in global configuration mode. It is recommended that NLS message authentication be enabled at all times.

### Procedure

|               | Command or Action                                                          | Purpose                                                                                                            |
|---------------|----------------------------------------------------------------------------|--------------------------------------------------------------------------------------------------------------------|
| <b>Step 1</b> | <b>enable</b><br><b>Example:</b><br>Router> enable                         | Enables privileged EXEC mode. <ul style="list-style-type: none"> <li>• Enter your password if prompted.</li> </ul> |
| <b>Step 2</b> | <b>configure terminal</b><br><b>Example:</b><br>Router# configure terminal | Enters global configuration mode.                                                                                  |



|               | Command or Action                                                                            | Purpose                                                               |
|---------------|----------------------------------------------------------------------------------------------|-----------------------------------------------------------------------|
| <b>Step 3</b> | <b>nls ag-id</b><br><b>Example:</b><br><pre>Router (config)# nls ag-id 100 auth-key 20</pre> | Configures the Authorization Group Identifier and Authentication Key. |
| <b>Step 4</b> | <b>end</b><br><b>Example:</b><br><pre>Router# end</pre>                                      | Exits global configuration mode and enters privileged EXEC mode.      |

## Examples

The following example shows the nls ag-id command with an Authorization Group ID of 100 and Authentication Key of 20.

```
Router (config)# nls ag-id 100 auth-key 20
```

## Configuring NLS Response Timeout

The NLS response timeout governs the time CMTS will wait for getting a response for a NLS authentication request.

To configure the NLS response timeout, use the nls ag-id command in global configuration mode. It is recommended that NLS message authentication be enabled at all times.

### Procedure

|               | Command or Action                                                                             | Purpose                                                                                                            |
|---------------|-----------------------------------------------------------------------------------------------|--------------------------------------------------------------------------------------------------------------------|
| <b>Step 1</b> | <b>enable</b><br><b>Example:</b><br><pre>Router&gt; enable</pre>                              | Enables privileged EXEC mode. <ul style="list-style-type: none"> <li>• Enter your password if prompted.</li> </ul> |
| <b>Step 2</b> | <b>configure terminal</b><br><b>Example:</b><br><pre>Router# configure terminal</pre>         | Enters global configuration mode.                                                                                  |
| <b>Step 3</b> | <b>nls resp-timeout</b><br><b>Example:</b><br><pre>Router (config)# nls resp-timeout 60</pre> | Configures the NLS response time.                                                                                  |

|        | Command or Action                                | Purpose                                                          |
|--------|--------------------------------------------------|------------------------------------------------------------------|
| Step 4 | <b>end</b><br><b>Example:</b><br><br>Router# end | Exits global configuration mode and enters privileged EXEC mode. |

## Examples

The following example shows the `nls resp-timeout` command with a response timeout setting of 60 seconds.

```
Router (config)# nls resp-timeout 60
```

## Additional References

The following sections provide references related to the CPD feature.

### Technical Assistance

| Description                                                                                                                                                                                                                                                                                                                                                                           | Link                                                                                                              |
|---------------------------------------------------------------------------------------------------------------------------------------------------------------------------------------------------------------------------------------------------------------------------------------------------------------------------------------------------------------------------------------|-------------------------------------------------------------------------------------------------------------------|
| The Cisco Support and Documentation website provides online resources to download documentation, software, and tools. Use these resources to install and configure the software and to troubleshoot and resolve technical issues with Cisco products and technologies. Access to most tools on the Cisco Support and Documentation website requires a Cisco.com user ID and password. | <a href="http://www.cisco.com/cisco/web/support/index.html">http://www.cisco.com/cisco/web/support/index.html</a> |

## Feature Information for Control Point Discovery

Use Cisco Feature Navigator to find information about the platform support and software image support. Cisco Feature Navigator enables you to determine which software images support a specific software release, feature set, or platform. To access Cisco Feature Navigator, go to the <https://cfng.cisco.com/> link. An account on the Cisco.com page is not required.



**Note** The following table lists the software release in which a given feature is introduced. Unless noted otherwise, subsequent releases of that software release train also support that feature.

*Table 353: Feature Information for Control Point Discovery*

| Feature Name            | Releases                    | Feature Information                                                                                               |
|-------------------------|-----------------------------|-------------------------------------------------------------------------------------------------------------------|
| Control Point Discovery | Cisco IOS XE Everest 16.6.1 | This feature was integrated into Cisco IOS XE Everest 16.6.1 on the Cisco cBR Series Converged Broadband Routers. |





## CHAPTER 112

# IPDR Streaming Protocol

The Cisco cBR Series Converged Broadband Routers supports the Internet Protocol Detail Record (IPDR) streaming protocol feature that provides high volume data exported from the network equipment to mediation systems such as the Operations Support Systems (OSS) or Business Support Systems (BSS). IPDR provides information about IP-based service usage and other activities that are used by OSS and BSS. This protocol provides a mechanism to collect data from various network elements or equipment using a push model as opposed to the conventional Simple Network Management Protocol (SNMP) polling mechanism.

Based on the DOCSIS 3.0 specifications, the IPDR feature optimizes time and resource efficiency in the transfer of large amounts of performance metrics to the management systems. DOCSIS 3.0 introduces five management features or the FCAPS model. FCAPS represents Fault, Configuration, Accounting, Performance and Security.

Your software release may not support all the features that are documented in this module. For the latest feature information and caveats, see the release notes for your platform and software release. The Feature Information Table at the end of this document provides information about the documented features and lists the releases in which each feature is supported.

Use Cisco Feature Navigator to find information about platform support and Cisco software image support. To access Cisco Feature Navigator, go to <http://tools.cisco.com/ITDIT/CFN/>. An account on <http://www.cisco.com/> is not required.

### Contents

- [Restrictions for Configuring IPDR Streaming Protocol, on page 1785](#)
- [Information About IPDR Streaming Protocol, on page 1786](#)
- [How to Configure IPDR Streaming Protocol, on page 1787](#)
- [Configuration Examples for IPDR Streaming Protocol, on page 1792](#)
- [Verifying IPDR Streaming Protocol, on page 1793](#)
- [Additional References, on page 1795](#)
- [Feature Information for IPDR Streaming Protocol, on page 1795](#)

## Restrictions for Configuring IPDR Streaming Protocol

- An IPDR exporter can be connected to many collectors, but it will only send data to the highest priority operating collector at any given time.
- Each IPDR session can be associated to one active (zero) or more standby collector with priority.

# Information About IPDR Streaming Protocol

IPDR Streaming Protocol is designed to address the need for a reliable, fast, efficient, and flexible export process of high volume data records such as billing, performance and diagnostic data.

The IPDR/SP process communicates with IPDR collectors. The IPDR streaming protocol supports multiple IPDR sessions. The architecture supports primary and secondary collectors for failover purposes. At any time, data is sent to only one collector. If the exporter to primary collector connection fails due to any reason, the data is sent to the secondary collector. Depending on the network configuration, you can have only one primary collector for each session, while for different sessions, you can have different primary collectors. For example, there may be a billing collector, a diagnostic collector, and so on.



---

**Note** IPDR exporter refers to the Cable Modem Termination System (CMTS) and the IPDR collector refers to the network equipment.

---

## Data Collection Methodologies

IPDR is the data generated or collected for various performance related metrics such as billing information, diagnostics, network topology, signal quality monitoring, and other management data. These data are based on the FCAPS model (Fault, Configuration, Accounting, Performance and Security.)

The IPDR client application communicates with the IPDR exporter using the IPDR\_GET\_SESSIONS message to identify the streams provided by the exporter, and the exporter sends responses to the client using the IPDR\_GET\_SESSIONS\_RESPONSE message. This data collection method is based on the *Operations Support System Interface Specification (CM-SP-OSSIv3.0-I13-101008)*.

The IPDR\_GET\_SESSIONS\_RESPONSE message includes the SessionBlock.reserved attribute to identify the IPDR session ID. This attribute helps the Cisco CMTS router define an IPDR session ID for each data collection mechanism supported for each IPDR service definition. This attribute was not used in Cisco IOS Releases earlier to Cisco IOS Release 12.2(33)SCE.

The IPDR feature defines methods for the collectors or network elements to collect data from the CMTS. Below is the list of collection methodologies:

**Time Interval Session:** In this method, the CMTS follows a schedule-based session to stream data at a periodic time interval. A time interval is the time gap between two adjacent sessions' start messages. This method is managed by the CMTS in controlling the start and stop operation of a session. The time interval session terminates after the CMTS exports the records.



---

**Note** During the course of a one-time interval when the CMTS is streaming records, if another time interval is expected, the CMTS will ignore the new time interval and continue exporting the data until the previous time interval ends.

---

**Event-based Session:** In this method, the CMTS can export records at any time, when the session is open. In other words, this method works on an open-ended session.

**Ad-hoc Session:** In this method, the CMTS creates a session, allows data streaming, and closes the session when the data export is complete or when a closing command is generated.

A new session is created by issuing the **ipdr session** command. After, the CMTS receives the FLOW\_START message from the collector, the CMTS exporter sends a SESSION\_START message to start exporting the IPDR data from the collector. After all data is transported, the exporter receives a ACK message from the collector, and then sends a SESSION\_STOP message to the collector. This method is known as the Ad-hoc session.

## How to Configure IPDR Streaming Protocol

This section describes the configuration tasks that are performed when using the IPDR streaming protocol feature on the Cisco CMTS platforms.



**Note** Use no ipdr command to remove the IPDR configuration.

### Configuring the IPDR Session

To enable the CMTS application to add a session to the IPDR exporter, use the ipdr session command in global configuration mode.

Use the no form of the command to remove the IPDR session.



- Note**
- The session ID must be unique. The valid range is from 1 to 127 on the cBR-8. A maximum of 20 IPDR sessions are supported by the cBR-8.
  - To remove an active session, you must deactivate it before removing it.

#### Procedure

|               | Command or Action                                                                                                      | Purpose                                                                                                            |
|---------------|------------------------------------------------------------------------------------------------------------------------|--------------------------------------------------------------------------------------------------------------------|
| <b>Step 1</b> | <b>enable</b><br><b>Example:</b><br>Router> enable                                                                     | Enables privileged EXEC mode. <ul style="list-style-type: none"> <li>• Enter your password if prompted.</li> </ul> |
| <b>Step 2</b> | <b>configure terminal</b><br><b>Example:</b><br>Router# configure terminal                                             | Enters global configuration mode.                                                                                  |
| <b>Step 3</b> | ipdr session session_id session_name session_descr<br><b>Example:</b><br>Router(config)# ipdr session 1 samis_sxn test | Enables the CMTS application to add a session to the IPDR exporter.                                                |

## Configuring the IPDR Type

To configure the IPDR session type, use the `ipdr type` command in global configuration mode. The IPDR session types that can be defined using this command are event type, time-interval type, and the ad hoc type.

Use the `no` form of the command to reset the session type to the default "event" type.

### Procedure

|               | Command or Action                                                                                                                     | Purpose                                                                                                            |
|---------------|---------------------------------------------------------------------------------------------------------------------------------------|--------------------------------------------------------------------------------------------------------------------|
| <b>Step 1</b> | <b>enable</b><br><b>Example:</b><br>Router> enable                                                                                    | Enables privileged EXEC mode. <ul style="list-style-type: none"> <li>• Enter your password if prompted.</li> </ul> |
| <b>Step 2</b> | <b>configure terminal</b><br><b>Example:</b><br>Router# configure terminal                                                            | Enters global configuration mode.                                                                                  |
| <b>Step 3</b> | <b>ipdr type session_id [ad-hoc   event   time-interval value]</b><br><b>Example:</b><br>Router(config)# ipdr type 1 time-interval 15 | Enables the CMTS application to configure an IPDR session type.                                                    |

### What to do next



**Note** Once the IPDR session type is configured, only the templates supported by this IPDR type are allowed be associated with it. Also, the console provides information about those templates that are not supported by this IPDR session type when the type is changed.

## Configuring the IPDR Collector

To configure the IPDR collector details, use the `ipdr collector` command in global configuration mode. The port number is used when an exporter creates an active connection.

### Procedure

|               | Command or Action                                  | Purpose                                                                                                            |
|---------------|----------------------------------------------------|--------------------------------------------------------------------------------------------------------------------|
| <b>Step 1</b> | <b>enable</b><br><b>Example:</b><br>Router> enable | Enables privileged EXEC mode. <ul style="list-style-type: none"> <li>• Enter your password if prompted.</li> </ul> |



|               | Command or Action                                                                                         | Purpose                                                                                                                                                                                                               |
|---------------|-----------------------------------------------------------------------------------------------------------|-----------------------------------------------------------------------------------------------------------------------------------------------------------------------------------------------------------------------|
| <b>Step 2</b> | <b>configure terminal</b><br><b>Example:</b><br><pre>Router# configure terminal</pre>                     | Enters global configuration mode.                                                                                                                                                                                     |
| <b>Step 3</b> | <b>ipdr collector</b><br><b>Example:</b><br><pre>Router(config)# ipdr collector federal 192.168.6.5</pre> | Enables the CMTS application to configure an IPDR collector and authenticate the IPDR protocol.<br><br><b>Note</b> Configure the NAT address in case of an IPDR collector that is operating in a NAT enabled network. |

## Configuring the IPDR Associate

To associate the collector with a session, use the ipdr associate command in global configuration mode.

### Before you begin

- You must deactivate the session before configuring the associate.

### Procedure

|               | Command or Action                                                                                                                    | Purpose                                                        |
|---------------|--------------------------------------------------------------------------------------------------------------------------------------|----------------------------------------------------------------|
| <b>Step 1</b> | <b>enable</b><br><b>Example:</b><br><pre>Router&gt; enable</pre>                                                                     | Enables privileged EXEC mode. Enter your password if prompted. |
| <b>Step 2</b> | <b>configure terminal</b><br><b>Example:</b><br><pre>Router# configure terminal</pre>                                                | Enters global configuration mode.                              |
| <b>Step 3</b> | <b>ipdr associate session_id collector_name priority</b><br><b>Example:</b><br><pre>Router(config)# ipdr associate 1 federal 1</pre> | Associates the collector with a session.                       |

## Configuring the IPDR Template

To add an IPDR template to the IPDR session, use the ipdr template command in global configuration mode. The template list can be viewed by entering a “?” at the command prompt.



**Note** • You can add only the system-supported templates.

**Procedure**

|               | Command or Action                                                                                         | Purpose                                                             |
|---------------|-----------------------------------------------------------------------------------------------------------|---------------------------------------------------------------------|
| <b>Step 1</b> | <b>enable</b><br><b>Example:</b><br>Router> enable                                                        | Enables privileged EXEC mode.<br>• Enter your password if prompted. |
| <b>Step 2</b> | <b>configure terminal</b><br><b>Example:</b><br>Router# configure terminal                                | Enters global configuration mode.                                   |
| <b>Step 3</b> | <b>ipdr template session_id template_name</b><br><b>Example:</b><br>Router(config)# ipdr template 1 SAMIS | Adds an IPDR template to the IPDR session.                          |

## Configuring the IPDR Exporter

IPDR exporter parameters such as keepalive timer count, the maximum number of unacknowledged records, and unacknowledged timeout interval value can be configured using the following commands.

- **ipdr exporter keepalive**—Sets the keepalive timer count value on the IPDR Exporter.
- **ipdr exporter max-unacked**—Sets the maximum number of unacknowledged records on the IPDR Exporter.
- **ipdr exporter ack-timeout**—Sets the time interval for acknowledged records on the IPDR Exporter.



**Note** The default value for DataAckTimeInterval is 60 seconds and the default value for DataAckSequenceInterval is 200 seconds.

You can set the values for the IPDR parameters to customize exporter for the collectors used in the facility. However, these commands are optional, so if not configured, the default values of the commands are used when **ipdr exporter start** command is executed.

**Procedure**

|               | Command or Action                | Purpose                                                        |
|---------------|----------------------------------|----------------------------------------------------------------|
| <b>Step 1</b> | <b>enable</b><br><b>Example:</b> | Enables privileged EXEC mode. Enter your password if prompted. |

|               | Command or Action                                                                                                        | Purpose                                                                                                                                                |
|---------------|--------------------------------------------------------------------------------------------------------------------------|--------------------------------------------------------------------------------------------------------------------------------------------------------|
|               | Router> enable                                                                                                           |                                                                                                                                                        |
| <b>Step 2</b> | <b>configure terminal</b><br><b>Example:</b><br>Router# configure terminal                                               | Enters global configuration mode.                                                                                                                      |
| <b>Step 3</b> | <b>ipdr exporter keepalive <i>time_interval</i></b><br><b>Example:</b><br>Router(config)# ipdr exporter keepalive 300    | (Optional) Sets the keepalive timer count for the IPDR Exporter. The valid range is from 5 to 300 seconds. The default value is 300.                   |
| <b>Step 4</b> | <b>ipdr exporter max-unacked <i>records</i></b><br><b>Example:</b><br>Router(config)# ipdr exporter max-unacked 200      | (Optional) Sets the number of maximum unacknowledged records on the IPDR Exporter. The valid range is from 5 to 200 records. The default value is 200. |
| <b>Step 5</b> | <b>ipdr exporter ack-timeout <i>time_interval</i></b><br><b>Example:</b><br>Router(config)# ipdr exporter ack-timeout 60 | (Optional) Sets the acknowledged records timeout interval on the IPDR Exporter. The valid range is from 5 to 60 seconds. The default value is 60.      |
| <b>Step 6</b> | <b>ipdr exporter start</b><br><b>Example:</b><br>Router(config)# ipdr exporter start                                     | Enables the CMTS application to start the IPDR exporter process to connect the exporter and the collector.                                             |

## Configure IPDR in IPv6 Mode

Starting from Cisco IOS XE Gibraltar 16.12.1, IPDR collector can be configured with IPv6 address and work in IPv6 mode. It means that the cBR-8 can monitor all IPv6 incoming connections from collectors.

Follow the example below to configure IPDR in IPv6 mode.

```
configure terminal
ipdr session 1 sess_v6 sess_v6
ipdr type 1 ad-hoc
ipdr collector coll_v6 2001:10:74:59:250:56FF:FEA7:5FB9 4737
ipdr associate 1 coll_v6 1
ipdr exporter start ipv6
cable metering ipdr-d3 session 1 type 1 full-records
```

It does not support to change connection type when the exporter is started. Stop exporter then change to another type.

## Start IPDR connection by CMTS

By default, the IPDR connections are started by collectors. Starting from Cisco IOS XE Gibraltar 16.12.1, IPDR connections can be initiated by CMTS.

Follow the example below to configure the IPDR exporter to start connection.

```
configure terminal
 ipdr exporter connection-active
```

If CMTS is configured to start IPDR connections, it also supports to configure the source-interface from which to start connection, which is optional.

Follow the example below to configure the IPDR exporter to start connection with specified interface.

```
configure terminal
 ipdr exporter connection-active source-interface TenGigabitEthernet4/1/0
```

# Configuration Examples for IPDR Streaming Protocol

## Example: Configuring the IPDR Session

The following example shows how to configure the IPDR session.

```
Router> enable
Router# configure terminal
Router(config)# ipdr session 1 test no_descr
```

## Example: Configuring the IPDR Type

The following example shows how to configure the IPDR “time-interval” session type for a time interval of 15 minutes.

```
Router> enable
Router# configure terminal
Router(config)# ipdr type 1 time-interval 15
```

## Example: Configuring the IPDR Collector

The following example shows how to configure the IPDR collector.

```
Router> enable
Router# configure terminal
Router(config)# ipdr collector federal 209.165.200.225
```

### Example for Configuring the IPDR Collector with NAT Address

This example shows the **nat-address** keyword used to configure the NAT address for an IPDR collector:

```
Router(config)#ipdr collector federal 192.0.2.225 nat-address 192.0.2.51
```

## Example: Configuring the IPDR Associate

The following example shows how to associate the collector with a session.

```
Router> enable
Router# configure terminal
Router(config)# ipdr associate 1 federal 1
```

## Example: Configuring the IPDR Template

The following example shows how to add an IPDR template to the IPDR session.

```
Router> enable
Router# configure terminal
Router(config)# ipdr template 1 SAMIS-TYPE1
```

## Example: Configuring the IPDR Exporter

The following example shows how to configure the IPDR exporter process to connect the exporter and the collector.

```
Router> enable
Router# configure terminal
Router(config)# ipdr exporter keepalive 300
Router(config)# ipdr exporter max-unacked 200
Router(config)# ipdr exporter ack_timeout 60
Router(config)# ipdr exporter start
```

## Verifying IPDR Streaming Protocol

This section describes the commands used for verification of the IPDR streaming protocol feature on the Cisco CMTS platforms.

### Verifying the IPDR Collector

The **show ipdr collector** command displays the collector information, message statistics, and event for all the sessions that are associated with the collector.

The following example shows the sample output for the **show ipdr collector** command.

```
Router# show ipdr collector federal
Collector Name: federal, IP: 192.0.2.0, Port: 0
2001-07-05T19:28:22 Collector in session 1 Statistics:
  Transmitted 12658 Acknowledged 12658 Enqueued 12658 Lost 0
  Last Event: Event Id 1 IPDR_EVENT_SERVER_CONNECTED - INCOMING
Router(config)#
```

## Verifying IPDR exporter

The **show ipdr exporter** command displays information about the IPDR Exporter state as listed below.

- started
- not started
- not initialized

Starting from Cisco IOS XE Gibraltar 16.12.1, the output of this command is updated to include active and passive mode for IPDR exporter.

The following example shows the sample output for the **show ipdr exporter** command:

```
Router# show ipdr exporter
Load for five secs: 7%/0%; one minute: 7%; five minutes: 7%
No time source, *15:52:25.468 CST Thu May 23 2019

IPDR exporter is started in passive mode.
Current parameters:
  KeepAliveInterval      :300
  AckTimeInterval       :60
  AckSequenceInterval   :200
Router#
```

## Verifying IPDR session

The **show ipdr session** command displays the session details such as the session ID, description, and the session state for all sessions as well as for a specific session.

The following example shows the sample output for the **all** keyword for the **show ipdr session** command.

```
Router# show ipdr session all
Session ID: 1, Name: utilsta, Descr: test, Started: False
```

The following example shows the sample output for the **session\_id** keyword for the **show ipdr session** command.

```
Router# show ipdr session 1
Session ID: 1, Name: utilsta, Descr: test, Started: False
2001-07-05T19:36:28 Statistics:
Transmitted 0 Acknowledged 0 Enqueued 0 Lost 0
queuedOutstanding 0 queuedUnacknowledged 0
1 Collectors in the session:
Name: federal, IPAddr: 192.0.2.0, Port: 0, Priority: 1
```

## Verifying IPDR Session Collector

The **show ipdr session collector** command displays the details of a collector that is associated with a specific session. Because there can be multiple collectors associated to a session, this command is used to show a specific session-collector pair.

The following example shows the sample output for the **show ipdr session collector** command.

```
Router# show ipdr session 1 collector federal
Session ID: 1, Name: utilsta, Descr: test, Started: False
Collectr Name: federal, IP: 192.0.2.0, Port: 0
2001-07-05T19:38:02 Collector in session 1 Statistics:
  Transmitted 0 Acknowledged 0 Enqueued 0 Lost 0
  Last Event: Event Id 0 WRONG_EVENT_ID
```

## Verifying IPDR Session Template

The **show ipdr session template** command displays the list of all active templates supported by a specific session.

The following example shows the sample output for the **show ipdr session template** command.

```
Router# show ipdr session 1 template
Template ID: 2, Name:
http://www.cablelabs.com/namespaces/DOCSIS/3.0/xsd/ipdr/DOCSIS-CMTS-CMSERVICE-FLOW-TYPE,
Type: DOCSIS-Type, KeyNumber: 22
Session 1 has totally 1 templates.
```

## Additional References

### Technical Assistance

| Description                                                                                                                                                                                                                                                                                                                                                                                                                                                                                                                                                             | Link                                                                           |
|-------------------------------------------------------------------------------------------------------------------------------------------------------------------------------------------------------------------------------------------------------------------------------------------------------------------------------------------------------------------------------------------------------------------------------------------------------------------------------------------------------------------------------------------------------------------------|--------------------------------------------------------------------------------|
| <p>The Cisco Support website provides extensive online resources, including documentation and tools for troubleshooting and resolving technical issues with Cisco products and technologies.</p> <p>To receive security and technical information about your products, you can subscribe to various services, such as the Product Alert Tool (accessed from Field Notices), the Cisco Technical Services Newsletter, and Really Simple Syndication (RSS) Feeds.</p> <p>Access to most tools on the Cisco Support website requires a Cisco.com user ID and password.</p> | <p><a href="http://www.cisco.com/support">http://www.cisco.com/support</a></p> |

## Feature Information for IPDR Streaming Protocol

Use Cisco Feature Navigator to find information about the platform support and software image support. Cisco Feature Navigator enables you to determine which software images support a specific software release, feature set, or platform. To access Cisco Feature Navigator, go to the <https://cfmng.cisco.com/> link. An account on the Cisco.com page is not required.



**Note** The following table lists the software release in which a given feature is introduced. Unless noted otherwise, subsequent releases of that software release train also support that feature.

**Table 354: Feature Information for Downstream Interface Configuration**

| Feature Name                      | Releases                       | Feature Information                                                                                              |
|-----------------------------------|--------------------------------|------------------------------------------------------------------------------------------------------------------|
| IPDR Streaming Protocol           | Cisco IOS XE Everest 16.6.1    | This feature was integrated into Cisco IOS XE Everest 16.6.1 on the Cisco cBR Series Converged Broadband Router. |
| IPDR connection initiated by CMTS | Cisco IOS XE Gibraltar 16.12.1 | This feature was supported on the Cisco cBR Series Converged Broadband Router.                                   |
| IPDR – IPV6 address               | Cisco IOS XE Gibraltar 16.12.1 | This feature was supported on the Cisco cBR Series Converged Broadband Router.                                   |
| IPDR support for DOCSIS 3.1       | Cisco IOS XE Amsterdam 17.3.1x | This feature was supported on the Cisco cBR Series Converged Broadband Router.                                   |





## CHAPTER 113

# Usage-Based Billing (SAMIS)

---

This document describes the Usage-based Billing feature for the Cisco Cable Modem Termination System (CMTS) routers, which provides subscriber account and billing information in the Subscriber Account Management Interface Specification (SAMIS) format. The SAMIS format is specified by the Data-over-Cable Service Interface Specifications (DOCSIS) Operations Support System Interface (OSSI) specification.

Your software release may not support all the features that are documented in this module. For the latest feature information and caveats, see the release notes for your platform and software release. The Feature Information Table at the end of this document provides information about the documented features and lists the releases in which each feature is supported.

Use Cisco Feature Navigator to find information about platform support and Cisco software image support. To access Cisco Feature Navigator, go to <http://tools.cisco.com/ITDIT/CFN/>. An account on <http://www.cisco.com/> is not required.

### Contents

- [Hardware Compatibility Matrix for the Cisco cBR Series Routers, on page 1797](#)
- [Prerequisites for Usage-Based Billing \(SAMIS\), on page 1798](#)
- [Restrictions for Usage-based Billing, on page 1799](#)
- [Information About Usage-based Billing, on page 1800](#)
- [How to Configure the Usage-based Billing Feature, on page 1812](#)
- [Monitoring the Usage-based Billing Feature, on page 1838](#)
- [Configuration Examples for Usage-based Billing, on page 1840](#)

## Hardware Compatibility Matrix for the Cisco cBR Series Routers



---

**Note** The hardware components that are introduced in a given Cisco IOS-XE Release are supported in all subsequent releases unless otherwise specified.

---

Table 355: Hardware Compatibility Matrix for the Cisco cBR Series Routers

| Cisco CMTS Platform                    | Processor Engine                                                                                                                                                                                  | Interface Cards                                                                                                                                                                                                                                                                                                                                                                                                                                                                                                                                                                                                                                                                                                                                                                                 |
|----------------------------------------|---------------------------------------------------------------------------------------------------------------------------------------------------------------------------------------------------|-------------------------------------------------------------------------------------------------------------------------------------------------------------------------------------------------------------------------------------------------------------------------------------------------------------------------------------------------------------------------------------------------------------------------------------------------------------------------------------------------------------------------------------------------------------------------------------------------------------------------------------------------------------------------------------------------------------------------------------------------------------------------------------------------|
| Cisco cBR-8 Converged Broadband Router | <p><b>Cisco IOS-XE Release 16.5.1 and Later Releases</b></p> <p>Cisco cBR-8 Supervisor:</p> <ul style="list-style-type: none"> <li>• PID—CBR-SUP-250G</li> <li>• PID—CBR-CCAP-SUP-160G</li> </ul> | <p><b>Cisco IOS-XE Release 16.5.1 and Later Releases</b></p> <p>Cisco cBR-8 CCAP Line Cards:</p> <ul style="list-style-type: none"> <li>• PID—CBR-LC-8D30-16U30</li> <li>• PID—CBR-LC-8D31-16U30</li> <li>• PID—CBR-RF-PIC</li> <li>• PID—CBR-RF-PROT-PIC</li> <li>• PID—CBR-CCAP-LC-40G</li> <li>• PID—CBR-CCAP-LC-40G-R</li> <li>• PID—CBR-CCAP-LC-G2-R</li> <li>• PID—CBR-SUP-8X10G-PIC</li> <li>• PID—CBR-2X100G-PIC</li> </ul> <p>Digital PICs:</p> <ul style="list-style-type: none"> <li>• PID—CBR-DPIC-8X10G</li> <li>• PID—CBR-DPIC-2X100G</li> </ul> <p>Cisco cBR-8 Downstream PHY Module:</p> <ul style="list-style-type: none"> <li>• PID—CBR-D31-DS-MOD</li> </ul> <p>Cisco cBR-8 Upstream PHY Modules:</p> <ul style="list-style-type: none"> <li>• PID—CBR-D31-US-MOD</li> </ul> |



**Note** Do not use DPICs (8X10G and 2x100G) to forward IP traffic, as it may cause buffer exhaustion, leading to line card reload.

The only allowed traffic on a DPIC interface is DEPI, UEPI, and GCP traffic from the Cisco cBR-8 router to Remote PHY devices. Other traffic such as DHCP, SSH, and UTSC should flow via another router, since DPICs cannot be used for normal routing.

## Prerequisites for Usage-Based Billing (SAMIS)

The Usage-based Billing feature has the following prerequisites:

- Cable modems must be compliant with DOCSIS 1.0 or DOCSIS 2.0, OSSI version 3.0 and DOCSIS 3.0.
- Cable modems that are being monitored should use a DOCSIS configuration file that defines upstream and downstream primary service flows using Service Class Naming (SCN [TLV 24/25, subTLV 4]). If dynamically-created service flows are to be monitored, they should also be created with SCN names.
- When the feature is operating in File mode, an external billing server must log into the Cisco CMTS to copy the billing records to the external server, using either Secure Copy (SCP) or Trivial File Transfer Protocol (TFTP). The Cisco CMTS cannot operate as a FTP or secure FTP (SFTP) server.
- When the feature is operating in Streaming mode in non-secure mode, an external billing server must be configured to receive the billing records at a configurable TCP port.
- When the feature is operating in Streaming mode in secure mode, the following are required:
  - The external billing server must be configured to receive the billing records at a configurable TCP port using a secure socket layer (SSL) connection.



---

**Tip** Several third-party solutions for SSL support on the billing application server are available <http://www.openssl.org/index.html>.

---

- A Certificate Authority (CA) must be configured and available to provide the required digital certificates to the billing application and Cisco CMTS router. The CA can be a public CA, such as Verisign, or a server on your private management network that is running software such as the Cisco Provisioning Center (CPC).
- To use the **full-records** keyword, the Cisco CMTS router must be running the Cisco IOS-XE releases.
- To use the **flow-aggregate** keyword for ipdr/ipdr-d3 the Cisco CMTS router must be running the Cisco IOS-XE releases.

When **flow-aggregate** is enabled, the service flows are combined into one record per cable modem:

- ServiceClassName element always returns a null value in IPDR records, even when service flows on the cable modem have a valid service class name.
- ServiceIdentifier element always returns a zero value.

## Restrictions for Usage-based Billing

The Usage-based Billing feature has the following restrictions and limitations:

- SNMP commands can be used to display or modify the Usage-based Billing configuration, and SNMP traps can be used to notify the billing application system when a billing record is available. However, SNMP commands cannot be used to retrieve billing records.
- Enabling IPDR mode through SNMP is not supported.

During a line card switchover, the items in the line card side are lost. Similarly, during a PRE switchover, those items in the RP side of the sflog file are lost.

If the user uses the SAMIS file destination, a PRE switchover also reinitializes that output file

- Billing records do not include information about multicast service flows and traffic counters.
- The packet counters displayed by CLI commands are reset to zero whenever the Cisco CMTS router is rebooted. The packet counters displayed by SNMP commands are not retained across router reloads, and SNMP MIB counters cannot be preserved during reloads. These counters are 64-bit values and could roll over to zero during periods of heavy usage.
- When configuring cable metering in the usage-based billing File Mode, the source-interface cannot be specified immediately after using the cable metering filesystem command. Once the cable metering filesystem command is used, the cable metering file will write to the bootflash. Until this operation is complete, no cable metering configuration will be allowed. After the file write operation is complete, the source-interface command (cable metering source-interface) can then be configured; and the metering file in the bootflash would need to be removed so that billing packets have the source-interface's IP address.



---

**Note** This cable metering restriction will not be a problem during reload.

---

- When configuring cable metering in the usage-based billing Streaming Mode, make sure that the loopback interface is accessible from the collector server. Telnetting to the IP address of the loopback interface from the collector server is a good method of testing whether the loopback interface is accessible from the collector server or not.

## Information About Usage-based Billing

### Feature Overview

The Usage-based Billing feature provides a standards-based, open application approach to recording and retrieving traffic billing information for DOCSIS networks. When enabled, this feature provides the following billing information about the cable modems and customer premises equipment (CPE) devices that are using the cable network:

- IP and MAC addresses of the cable modem.
- Service flows being used (both upstream and downstream service flows are tracked).
- IP addresses for the CPE devices that are using the cable modem.
- Total number of octets and packets received by the cable modem (downstream) or transmitted by the cable modem (upstream) during the collection period.
- Total number of downstream packets for the cable modem that the CMTS dropped or delayed because they would have exceeded the bandwidth levels allowed by the subscriber's service level agreement (SLA).

Billing records are maintained in a standardized text format that the service provider can easily integrate into their existing billing applications. Service providers can use this information to determine which users might be potential customers for service upgrades, as well as those customers that might be trying to exceed their SLA limits on a regular basis.

# Usage-Based Billing and DOCSIS Support on the Cisco CMTS Routers

The usage-based billing feature supports these DOCSIS features on the Cisco CMTS routers:

- DOCSIS 1.0, DOCSIS 2.0, and DOCSIS 3.0 compliant cable modems are supported.
- Best Effort service flows are supported for DOCSIS-compliant cable modems.
- Secondary service flows are supported for DOCSIS-compliant cable modems.
- Dynamic service flows are supported for DOCSIS-compliant cable modems.
- Information about deleted service flows is available only for DOCSIS 1.1 service flows but not for DOCSIS 1.0 service flows.
- Support for terminated service flows must be enabled using the **cable sflog** command in global mode.

## Standards

The Usage-based Billing feature is based on several open standards, allowing it to be supported by a wide range of commercial and custom-written billing applications. The following standards provide the major guidelines for writing and using the billing records that the CMTS produces:

- Extensible Markup Language (XML)—A metalanguage that in turn can easily define other markup languages to contain any kind of structured information, such as billing records. An XML-based approach allows the collected billing information to be used by and distributed among many different billing applications from different vendors. It also allows the format to be easily updated and customized to meet the needs of different providers.
- IP Detail Record (IPDR)—An open, vendor-independent standard, defined in the *Network Data Management—Usage (NDM-U) For IP-Based Services* specification, to simplify billing and usage record-keeping for any type of services that can be delivered over an IP-based network. Service providers can use IPDR to create unified billing applications for all of their services, such as DOCSIS or Voice-over-IP, even though those services use different protocols and application servers.
- DOCSIS Operations Support System Interface (OSSI) specification—A DOCSIS specification that defines the requirements for the network management of a DOCSIS network, including a Subscriber Account Management Interface Specification (SAMIS) for a billing record interface. The DOCSIS 2.0 version of this specification states that a CMTS is not required to provide a billing interface, but if the CMTS does provide a billing interface, it must be based on the IPDR/XML standards.



---

**Tip** For further information about these standards, see the documents listed in the “Standards” section on page 38.

---

## IPDR Service Definition Schemas

To standardize the management of objects, service definition schemas are associated with IPDR just as MIBs are associated to SNMP.

The schemas are supported on Cisco IOS-XE releases.

### IPDR Schema List for DOCSIS 3.0

For more information, see the OSSI specification document at <https://www.cablelabs.com/cm-sp-ossiv3-0-i05-071206>.

Table 356: IPDR Schema List for DOCSIS 3.0

| Category                                  | Service Definition           | Schema Definition                              | Collection Method            |
|-------------------------------------------|------------------------------|------------------------------------------------|------------------------------|
| SAMIS                                     | SAMIS-TYPE-1                 | DOCSIS-SAMIS-TYPE-1_3.5.1-A.1.xsd              | time interval, ad-hoc        |
|                                           | SAMIS-TYPE-2                 | DOCSIS-SAMIS-TYPE-2_3.5.1-A.1.xsd              | time interval, ad-hoc        |
| Diagnostic Log Service Definition Schemas | DIAG-LOG-TYPE                | DOCSIS-DIAG-LOG-TYPE_3.5.1-A.2.xsd             | ad-hoc                       |
|                                           | DIAG-LOG-EVENT-TYPE          | DOCSIS-DIAG-LOG-EVENT-TYPE_3.5.1-A.2.xsd       | event                        |
|                                           | DIAG-LOG-DETAIL-TYPE         | DOCSIS-DIAG-LOG-DETAIL-TYPE_3.5.1-A.2.xsd      | time interval, ad-hoc, event |
| Spectrum Management                       | SPECTRUM-MEASUREMENT-TYPE    | DOCSIS-SPECTRUM-MEASUREMENT-TYPE_3.5.1-A.2.xsd | time interval, ad-hoc        |
| CMTS CM Registration Status Information   | CMTS-CM-REG-STATUS-TYPE      | DOCSIS-CMTS-CM-REG-STATUS-TYPE_3.5.1-B.2.xsd   | time interval, ad-hoc, event |
| CMTS CM Registration Status Information   | CMTS-CM-REG-STATUS-TYPE-2008 | DOCSIS-CMTS-CM-REG-STATUS-TYPE_3.5.1-A.1.xsd   | time interval, ad-hoc, event |
| CMTS CM Upstream Status Information       | CMTS-CM-US-STATS-TYPE        | DOCSIS-CMTS-CM-US-STATS-TYPE_3.5.1-A.2.xsd     | time interval, ad-hoc        |
| CMTS Topology                             | CMTS-TOPOLOGY-TYPE           | DOCSIS-CMTS-TOPOLOGY-TYPE_3.5.1-A.3.xsd        | ad-hoc, event                |
| CPE Information                           | CPE-TYPE                     | DOCSIS-CPE-TYPE_3.5.1-A.2.xsd                  | ad-hoc, event                |
| CMTS Utilization Statistics               | CMTS-US-UTIL-STATS-TYPE      | DOCSIS-CMTS-US-UTIL-STATS-TYPE_3.7-A.6.xsd     | event                        |
|                                           | CMTS-DS-UTIL-STATS-TYPE      | DOCSIS-CMTS-DS-UTIL-STATS-TYPE_3.5.1-A.3.xsd   | event                        |

The schemas listed in the table are supported by implementing the respective Collectors, which work as SNMP agents to generate these IPDR records according to management information of the system.



---

**Note** In the 17.12.1y version, a new field "RecCreationTime" is added for the CMTS-TOPOLOGY-TYPE and CMTS-US-UTIL-STATS-TYPE schema definitions. This field contains a 64-bit count of milliseconds UTC time stamp at the time the data for the record was acquired, in order to return the time when the record is created in CMTS for these two categories.

---

## IPDR CM-STATUS-2008

Cisco IOS-XE Release 16.5.1 supports the IPDR CM-STATUS 2008 version for forward compatibility to support old IPDR collectors. In the IPDR CM-STATUS 2008 version, the CmtsRcsId and CmtsTcsId objects are 16 bits in length whereas in the CM-STATUS version both these objects are 32 bits in length.

The CmtsRcsId object in the CM-STATUS-2008 version returns the lower 16 bits of value from the CM-STATUS version. But, the CmtsTcsId object returns the same value for both the CM-STATUS-2008 and CM-STATUS version since the value does not exceed 16 bits in both the schemas.

## DOCSIS SAMIS Service Definitions

SAMIS for DOCSIS 3.0 service definitions are well structured and has two versions—SAMIS-TYPE-1 and SAMIS-TYPE-2 and provide a different level of information details than SAMIS.

DOCSIS 2.0 SAMIS supports only event session (default type) and DOCSIS 3.0 SAMIS TYPE 1 and DOCSIS 3.0 SAMIS TYPE 2 support only interval and ad-hoc sessions.

SAMIS is collected based on configurable time intervals. Each interval is a different document and the Exporter stops and starts a new session for a new interval. The interval starts from the last metering that has either succeeded or failed, unlike the time-interval session that has a fixed starting point and an interval.



---

**Note** The SAMIS schema can be configured with the **cable metering ipdr session** command SAMIS-TYPE-1 and SAMIS-TYPE-2 schemas can be configured through the **cable metering ipdr-d3** command. These schemas are mutually exclusive of each other.

---

## Limitation To DOCSIS SAMIS

- Only schemas that are consistent with the **cable metering ipdr| ipdr-d3** command works. If none of the schemas are consistent, none of them work.
- Changing the SAMIS IPDR type cancels exporting IPDR data.

## DOCSIS Diagnostic Log Service Definitions

This service definition defines the IPDR Streaming using a two-step process:

- SNMP or other configuration management interface, such as the CLI is used to configure the Diagnostic Log.
- IPDR/SP is used to stream the Diagnostic Log instances.

These Diagnostic Log service definition schemas support the following collection methods:

- The Cisco CMTS supports streaming of the DIAG-LOG-TYPE record collections as an ad-hoc session.

- The Cisco CMTS supports streaming of DIAG-LOG-EVENT-TYPE record collections as an event session. For event-based Diagnostic Log records, the Cisco CMTS streams the record when the event is logged in the Diagnostic Log and an IPDR message is transmitted to the Collector.
- The DOCSIS-DIAG-LOG-DETAIL-TYPE supports the following collection methods:
  - Time interval—Follows a schedule based on session configuration to export data on a periodic time interval. When a given time interval end is reached, the Exporter collects the diagnostic log, then streams the record to the Collector associated with this session. For time interval based Diagnostic Log records, the Cisco CMTS streams a snapshot of the Diagnostic Log at the scheduled collection time.
  - Ad-hoc—When the Exporter receives a "FlowStart" message, it triggers the application to collect the diagnostic record and send the data to the Collector.
  - Event—When a diagnostic log record is created, an ipdr message is transmitted to the Collector. For more information, see the Operations Support System Interface (OSSI) Specification.

### DOCSIS Spectrum Measurement Service Definition

This service definition schema defines the IPDR schema for the enhanced signal quality monitoring feature.

The DOCSIS-SPECTRUM-MEASUREMENT-TYPE schema supports the following collection methods:

- Time interval—Follows a schedule based on session configuration to export data on a periodic time interval. When a given time interval end is reached, the Exporter collects the spectrum information, then streams the records to the Collector.
- Ad-hoc—When the Exporter receives a "FlowStart" message, it triggers the application to collect the spectrum information and send the data to the Collector.

### DOCSIS CMTS CM Registration Status Service Definition

This service definition schema defines the IPDR service definition schema for the CMTS CM Registration Status information.

The DOCSIS-CMTS-CM-REG-STATUS-TYPE schema supports the following collection methods:

- Time interval—Follows a schedule based on session configuration to export data on a periodic time interval. When a given time interval end is reached, the Exporter collects the CM status information, then streams the records to the Collector.
- Ad-hoc—When the Exporter receives a "FlowStart" message, it triggers the application to collect all status information of the cable modems and send the data to the Collector.
- Event—When a cable modem goes from "offline" status to "online" or changes to "offline" from "online" (not including intermediate state changes), the Exporter invokes the application to collect the cable modem status information and sends the data to the Collector. For more information, see the Operations Support System Interface (OSSI) Specification.

### DOCSIS CMTS CM Upstream Status Service Definition

This service definition schema define the cable modem registration status objects and upstream status objects from the cable modem and the Cisco CMTS perspective. In the CmtsCmUsEqData IPDR schema field, configure the **cable upstream equalization-coefficient** command under the corresponding MAC domain to enable the feature to have data. For more information on this command, see the [Cisco IOS CMTS Cable Command Reference Guide](#).

The DOCSIS-CMTS-CM-US-STATS-TYPE schema support the following collection methods:



- Time interval—Follows a schedule based on session configuration to export data on a periodic time interval. When a given time interval end is reached, the Exporter collects the cable modem upstream status information, then streams the records to the Collector.
- Ad-hoc—When the Exporter receives a "FlowStart" message, it triggers the application to collect all upstream status information of the cable modem and send the data to the Collector.

### DOCSIS CMTS Topology Service Definition

In the case of an event session, the event means a change of the topology.

This service definition schema defines the IPDR service definition schema for the CMTS Topology information.

The DOCSIS-CMTS-TOPOLOGY-TYPE schema supports the following collection methods:

- Ad-hoc—Sends the entire picture of all fiber-nodes.
- Event—Sends only the updated channels status of the fiber nodes.

### DOCSIS CPE Service Definition

The DOCSIS-CPE-TYPE schema supports the following collection methods:

- Ad-hoc—Follows a schedule based on session configuration to export data on a periodic time interval. When a given time interval end is reached, the Exporter collects the CPE status information, then transfers the records to the Collector.
- Event—When new CPE is added, the status of the CPE changes (including change in IP address), or a new CPE replaces an old one (in this case, two messages are displaced— removal of the old CPE and addition of the new CPE). For more information, see the Operations Support System Interface (OSSI) Specification.

### DOCSIS CMTS Utilization Statistics Service Definition

The CMTS Utilization Statistics mainly focuses on channel utilization. It covers CMTS MAC Domain, channel identifier, and the upstream or downstream utilization attributes and counters.

The DOCSIS-CMTS-US-UTIL-STATS-TYPE schemas defines upstream utilization statistics for a specified upstream logical channel interface for the specified Cisco CMTS. The interval can be configured through Channel Utilization Interval.

The DOCSIS-CMTS-DS-UTIL-STATS-TYPE schema defines downstream utilization statistics for a specified downstream interface for the specified Cisco CMTS. The interval can be configured through Channel Utilization Interval.

For more information, see the IPDR Streaming Protocol on the Cisco CMTS Routers guide at the following URL:

[IPDR Streaming Protocol](#)

These schemas support only interval-driven event session for the entire downstream and upstream. The interval is defined in the docsIfCmtsChannelUtilizationInterval MIB and it creates document for every exporting.



---

**Note** The UsUtilTotalCntnReqDataMslots, UsUtilUsedCntnReqDataMslots, and UsUtilCollCntnReqDataMslots MIBs are not supported on the Cisco CMTS implementation.

---

The DsUtilTotalBytes MIB for RF Gateway RF channels is the maximum counter of bytes this RF channel can pass during an interval.

## IPDR Schema List for DOCSIS 3.1

For more information, see the OSSI specification document at <https://www.cablelabs.com/>.

Table 357: IPDR Schema List for DOCSIS 3.1

| Category                                | Service Definition                   | Schema Definition                                         | Collection Method            |
|-----------------------------------------|--------------------------------------|-----------------------------------------------------------|------------------------------|
| CMTS CM Registration Status Information | CMTS-CM-REG-STATUS-TYPE              | DOCSIS-CMTS-CM-REG-STATUS-TYPE_3.5.1-B.2.xsd              | time interval, event, ad-hoc |
| CMTS CM Service Flow Information        | CMTS-CM-SERVICE-FLOW-TYPE            | DOCSIS-CMTS-CM-SERVICE-FLOW-TYPE_3.5.1-B.1.xsd            | ad-hoc                       |
| CMTS CM Profile Status Information      | CMTS-CM-DS-OFDM-PROFILE-STATUS-TYPE  | DOCSIS-CMTS-CM-DS-OFDM-PROFILE-STATUS-TYPE_3.5.1-B.1.xsd  | time interval, event         |
|                                         | CMTS-CM-US-OFDMA-PROFILE-STATUS-TYPE | DOCSIS-CMTS-CM-US-OFDMA-PROFILE-STATUS-TYPE_3.5.1-B.3.xsd | time interval                |
| CMTS CM Channel Status Information      | CMTS-CM-DS-OFDM-STATUS-TYPE          | DOCSIS-CMTS-CM-DS-OFDM-STATUS-TYPE_3.5.1-B.1.xsd          | time interval, event         |
|                                         | CMTS-CM-US-OFDMA-STATUS-TYPE         | DOCSIS-CMTS-CM-US-OFDMA-STATUS-TYPE_3.5.1-B.3.xsd         | time interval, event         |
| Profile Statistics Information          | DS-OFDM-PROFILE-STATS-TYPE           | DOCSIS-DS-OFDM-PROFILE-STATS-TYPE_3.5.1-B.1.xsd           | time interval                |
|                                         | US-OFDMA-PROFILE-STATS-TYPE          | DOCSIS-US-OFDMA-PROFILE-STATS-TYPE_3.5.1-B.1.xsd          | time interval                |

### CMTS CM Registration Status Service Definition

DOCSIS-CMTS-CM-REG-STATUS is an IPDR Service Definition Schema that defines the Registration status of the CM as perceived by the CMTS. It supports collecting IPDR record at specified time interval.

### CMTS CM Service Flow Service Definition

DOCSIS-CMTS-CM-SERVICE-FLOW is an IPDR Service Definition schema defining details of service flows. It supports ad-hoc collecting IPDR record.

### CMTS CM Profile Status Service Definition

DOCSIS-CMTS-CM-DS-OFDM-PROFILE-STATUS is an IPDR Service Definition Schema that provides data on the status of each CM's OFDM Downstream Channel Profiles. This definition supports multiple OFDM downstream channels and profiles per CM. It supports the following collection methods:

- Event - When DOCSIS 3.1 modems is sending the following CM-STATUS messages for OFDM channels:
  - 16 DS OFDM profile failure

- 24 FEC recovery on OFDM profile
  - 20 NCP profile failure
  - 22 NCP profile recovery
- Time-interval - Before the IPDR records is sent at specified time interval, create DOCSIS 3.1 modems in partial service MIB docsIf31CmtsCmDsOfdmProfileStatusEntry by sending the CM-STATUS messages listed in event trigger.

DOCSIS-CMTS-CM-US-OFDMA-PROFILE-STATUS is an IPDR Service Definition Schema that provides data on the status of each CM's OFDMA Upstream Channel Profiles. This definition supports multiple OFDMA upstream channels and profiles per CM. It supports collecting IPDR record at specified time interval.

### CMTS CM Channel Status Service Definition

DOCSIS-CMTS-CM-DS-OFDM-STATUS is an IPDR Service Definition Schema for monitoring the OFDM downstream channel status of the CM as perceived by the CMTS. It supports the following collection methods:

- Event - When DOCSIS 3.1 modems is sending the following CM-STATUS messages for OFDM channels:
  - 1 NP Channel MDD timeout
  - 4 NP Channel MDD recovery
  - 2 QAM/FEC lock failure
  - 5 QAM/FEC lock recovery
  - 16 DS OFDM profile failure
  - 24 FEC recovery on OFDM profile
  - 20 NCP profile failure
  - 22 NCP profile recovery
  - 21 Loss of FEC Lock on PLC
  - 23 FEC recovery on PLC channel
- Time-interval - Before the IPDR records is sent at specified time interval, create DOCSIS 3.1 modems in partial service MIB docsIf31CmtsCmDsOfdmChannelStatusEntry by sending the CM-STATUS messages listed in event trigger.

### Profile Statistics Service Definition

DOCSIS-DS-OFDM-PROFILE-STATS is an IPDR Service Definition Schema that provides statistics on OFDM Downstream Profiles. This definition supports multiple OFDM downstream channels and profiles. It supports collecting IPDR record at specified time interval.

DOCSIS-US-OFDMA-PROFILE-STATS is an IPDR Service Definition Schema that provides statistics on OFDMA Upstream Profiles. This definition supports multiple OFDMA upstream channels and profiles. It supports collecting IPDR record at specified time interval.

## Modes of Operation

The Usage-based Billing feature can operate in three modes:

- **File Mode**—In file mode, the CMTS collects the billing record information and writes the billing records to a file on a local file system, using a file name that consists of the router's hostname followed by a timestamp of when the file was written. A remote application can then log into the CMTS and transfer the billing record file to an external server where the billing application can access it.

The remote application can use the Secure Copy Protocol (SCP) or the Trivial File Transfer Protocol (TFTP) to transfer the file. After a successful transfer, the remote application then deletes the billing record file, which signals the CMTS that it can create a new file. The remote application can either periodically log into the CMTS to transfer the billing record file, or it can wait until the CMTS sends an SNMPv2 trap to notify the application that a billing record file is available.

- **Streaming Mode**—In streaming mode, the CMTS collects the billing record information and then regularly transmits the billing record file to an application on an external server, using either a non-secure TCP connection or a secure sockets layer (SSL) connection. The billing record data collected is streamed in real time; and if streaming is unsuccessful, then the SAMIS data is sent only at the next interval.

If the CMTS fails to establish a successful connection with the external server, it retries the connection between one to three times, depending on the configuration. If the CMTS continues to fail to connect with the external server, the Cisco CMTS sends an SNMPv2 trap to notify the SNMP manager that this failure occurred.

In streaming mode, you can configure the CMTS to transmit the billing record file at regular intervals. Typically, the interval chosen would depend on the number of cable modems and the size of the billing record files that the CMTS produces.

- **IPDR Mode**—In the IPDR mode, the IPDR export process communicates with IPDR Collectors. The architecture supports multiple Collectors distinguished by priority value for failover purposes. The smaller the number of Collectors, the higher is the priority value. Associating one session to two or more Collectors with the same priority value is regarded as random priority. At any given time, data is sent to only the available highest priority Collector. If the highest priority Collector connection fails due to any reason, the data is sent to the next available highest priority Collector. After a higher priority Collector comes back online, it will fail over again. Depending on the network configuration, you can have different primary Collectors for different IPDR sessions. For example, there may be a billing Collector or a diagnostic Collector.

## Billing Record Format

Each billing record is an ASCII text file using XML formatting to encode the billing record objects that are required by the DOCSIS specifications. This file can be read by any billing application that can be configured to parse XML data files.

The table lists the objects that are contained in each billing record that the CMTS generates. This table shows the object's name, as it appears in the billing record, and a description of that object.

**Table 358: Billing Record Objects**

| Object Name      | Description                                                                                    |
|------------------|------------------------------------------------------------------------------------------------|
| IPDRcreationTime | (Appears in header of billing record) Date and time that the CMTS created the billing created. |

| Object Name                                                          | Description                                                                                                                                                                                                                                                                                                                    |
|----------------------------------------------------------------------|--------------------------------------------------------------------------------------------------------------------------------------------------------------------------------------------------------------------------------------------------------------------------------------------------------------------------------|
| serviceClassName                                                     | Service Class Name (SCN) identifying the service flow (for example, BronzeDS).                                                                                                                                                                                                                                                 |
| CMmacAddress                                                         | MAC Address of the cable modem, expressed as six hexadecimal bytes separated by dashes (for example, 00-00-0C-01-02-03).                                                                                                                                                                                                       |
| CMipAddress                                                          | IP address for the cable modem, expressed in dotted decimal notation (for example, 192.168.100.101).                                                                                                                                                                                                                           |
| CMdocsisMode                                                         | Version of DOCSIS QoS provision that the cable modem is currently using (DOCSIS 1.0 or 1.1).                                                                                                                                                                                                                                   |
| CPEipAddress                                                         | IP address for each CPE device that is using this cable modem, expressed in dotted decimal notation. This object is optional and can be suppressed to improve performance by reducing the size of the billing record files.                                                                                                    |
| CMTSipAddress                                                        | IP address for the CMTS, expressed in dotted decimal notation.                                                                                                                                                                                                                                                                 |
| CMTShostName                                                         | Fully qualified hostname for the CMTS (for example, cmts01.cisco.com).                                                                                                                                                                                                                                                         |
| CMTSsysUpTime                                                        | Amount of time, in hundredths of a second, since the last initialization of the CMTS management interface, expressed as a 32-bit decimal number (0 to 4,294,967,296).                                                                                                                                                          |
| RecType (SFType renamed to RecType in Cisco IOS Release 12.3(17a)BC) | Type of service flow being described: <ul style="list-style-type: none"> <li>• <b>Interim</b>—the service flow was active throughout the collection period and should be reported as 1.</li> <li>• <b>Stop</b>—the service flow was deleted at some point during the collection period and should be reported as 2.</li> </ul> |
| serviceIdentifier                                                    | Service flow ID assigned to this service flow by the CMTS, expressed as a decimal number.<br><br><b>Note</b> For DOCSIS 1.0 cable modems, the SFID field always shows the primary service flow for the upstream or downstream.                                                                                                 |
| serviceDirection                                                     | Direction for the service flow ( <b>Downstream</b> or <b>Upstream</b> ).                                                                                                                                                                                                                                                       |
| serviceOctetsPassed                                                  | Total number of octets received by the cable modem (downstream service flows) or transmitted by the cable modem (upstream service flows) during the collection period, expressed as a 64-bit decimal number.                                                                                                                   |
| servicePktsPassed                                                    | Total number of packets received by the cable modem (downstream service flows) or transmitted by the cable modem (upstream service flows) during the collection period, expressed as a 64-bit decimal number.                                                                                                                  |
| SLAdropPkts                                                          | (Downstream service flows only) Total number of downstream packets for the cable modem that the CMTS dropped because otherwise they would have exceeded the bandwidth levels allowed by the subscriber's service level agreement (SLA), expressed as a 64-bit decimal number.                                                  |

| Object Name        | Description                                                                                                                                                                                                                                                                                  |
|--------------------|----------------------------------------------------------------------------------------------------------------------------------------------------------------------------------------------------------------------------------------------------------------------------------------------|
| SLAdelayPkts       | (Downstream service flows only) Total number of packets that the CMTS delayed transmitting on the downstream to the cable modem because otherwise they would have exceeded bandwidth levels allowed by the subscriber's service level agreement (SLA), expressed as a 64-bit decimal number. |
| CMTScatvIfIndex    | The ifIndex of the MAC interface.                                                                                                                                                                                                                                                            |
| CMTScatvIfName     | The ifName of the CMTS CATV (MAC) interface associated with this cable modem.                                                                                                                                                                                                                |
| CMTSupIfName       | The ifName of the CMTS Upstream interface associated with this cable modem.                                                                                                                                                                                                                  |
| CMTSdownIfName     | The ifName of the CMTS Downstream interface associated with this cable modem.                                                                                                                                                                                                                |
| CMcpeFqdn          | FQDNs for cable modem associated CPEs.                                                                                                                                                                                                                                                       |
| serviceTimeCreated | Timestamp for SF creation (consistent with QoS MIB model).                                                                                                                                                                                                                                   |
| serviceTimeActive  | The active time of the SF in seconds.                                                                                                                                                                                                                                                        |



**Note** Because the byte and packet counters are 64-bit values, it is possible for them to wrap around to zero during a billing period. The billing application should use the sysUpTime value along with the counters to determine whether the counters have wrapped since the last billing period. If a counter appears to regress, and if the current sysUpTime indicates this billing cycle is the next scheduled cycle for this particular cable modem, you can assume that the counter has wrapped during the billing cycle.



**Note** These billing record objects are defined in Appendix B, *IPDR Standards Submission for Cable Data Systems Subscriber Usage Billing Records*, in the *DOCSIS 2.0 OSSSI Specification* (SP-OSSIV2.0-IO3-021218).

The following example shows a sample IPDR billing record for a downstream service flow:

```
<?xml version="1.0" encoding="UTF-8"?>
<IPDRDoc xmlns="http://www.ipdr.org/namespaces/ipdr"
xmlns:xsi="http://www.w3.org/2001/XMLSchema-instance"
xsi:schemaLocation="DOCSIS-3.1-B.0.xsd"
docId="C341A679-0000-0000-0000-000BBF54D000"
creationTime="2002-05-25T14:41:29Z"
IPDRRecorderInfo="CMTS01"
version="3.1">
</IPDR>
<IPDR xsi:type="DOCSIS-Type">
<IPDRcreationTime>2003-09-18T16:52:34Z</IPDRcreationTime>
<CMTShostname>R7519-UBR7246.cisco.com</CMTShostname>
<CMTSipAddress>1.8.8.21</CMTSipAddress>
<CMTSsysUpTime>287315 </CMTSsysUpTime>
<CMTScatvIfName>Cable8/0/0</CMTScatvIfName>
```

```

<CMTScatvIfIndex>13</CMTScatvIfIndex>
<CMTSupIfName>Ca8/0/0-upstream0</CMTSupIfName>
<CMTSupIfType>129</CMTSupIfType>
<CMTSdownIfName>Ca8/0/0-downstream</CMTSdownIfName>
<CMmacAddress>00-00-39-AB-D4-53</CMmacAddress>
<CMdocsisMode>1.0</CMdocsisMode>
<CMipAddress>3.8.21.3</CMipAddress>
<CPEipAddress></CPEipAddress>
<RecType>1</SFtype>
<serviceIdentifier>3</serviceIdentifier>
<serviceClassName></serviceClassName>
<serviceDirection>2</serviceDirection>
<serviceOctetsPassed>23457</ServiceOctetsPassed>
<servicePktsPassed>223</ServicePktsPassed>
<serviceSlaDropPkts>2</serviceSlaDropPkts>
<serviceSlaDelayPkts>0</serviceSlaDelayPkts>
<serviceTimeCreated>11000</serviceTimeCreated>
<serviceTimeActive>15890</serviceTimeActive>
</IPDR>
</IPDRDoc>

```

The following example shows a sample IPDR billing record for an upstream service flow:

```
<?xml version="1.0" encoding="UTF-8"?>
```

```

<IPDRDoc xmlns="http://www.ipdr.org/namespaces/ipdr"
xmlns:xsi="http://www.w3.org/2001/XMLSchema-instance"
xsi:schemaLocation="DOCSIS-3.1-B.0.xsd"
docId="docId="C3146152-0000-0000-0000-000BBF7D5800"
creationTime="2003-09-18T16:52:34Z"
IPDRRecorderInfo="CMTS01-UBR7246.cisco.com"
version="3.1">
<IPDR xsi:type=" DOCSIS-Type">
<IPDRcreationTime>2003-09-18T16:52:34Z</IPDRcreationTime>
<CMTShostname>R7519-UBR7246.cisco.com</CMTShostname>
<CMTSipAddress>1.8.8.21</CMTSipAddress>
<CMTSsysUpTime>287315 </CMTSsysUpTime>
<CMTScatvIfName>Cable8/0/0</CMTScatvIfName>
<CMTScatvIfIndex>13</CMTScatvIfIndex>
<CMTSupIfName>Ca8/0/0-upstream0</CMTSupIfName>
<CMTSupIfType>129</CMTSupIfType>
<CMTSdownIfName>Ca8/0/0-downstream</CMTSdownIfName>
<CMmacAddress>00-00-39-18-8A-4D</CMmacAddress>
<CMdocsisMode>1.0</CMdocsisMode>
<CMipAddress>3.8.21.14</CMipAddress>
<CPEipAddress></CPEipAddress>
<RecType>1</SFtype>
<serviceIdentifier>3</serviceIdentifier>
<serviceClassName></serviceClassName>
<serviceDirection>1</serviceDirection>
<serviceOctetsPassed>1404</ServiceOctetsPassed>
<servicePktsPassed>6</ServicePktsPassed>
<serviceSlaDropPkts>0</serviceSlaDropPkts>
<serviceSlaDelayPkts>0</serviceSlaDelayPkts>
<serviceTimeCreated>11000</serviceTimeCreated>
<serviceTimeActive>15890</serviceTimeActive>
</IPDR>
</IPDRDoc>

```

## SNMP Support

Cisco cBR Series Converged Broadband Routers support the following MIBs that provide SNMPv2 support for the Usage-based Billing feature:

### CISCO-CABLE-METERING-MIB

- Supports configuration of the usage-based billing feature using SNMPv2 commands.
- Displays the current usage-based billing configuration using SNMPv2 commands.
- Sends SNMPv2 traps based on the following usage-based billing events:
  - The Cisco CMTS reports that a new billing record is available.
  - The Cisco CMTS reports that a failure occurred in writing the most recent billing record (for example, the disk is full).
  - The Cisco CMTS reports that it could not successfully open a secure SSL connection to stream a billing record to the billing server.

### CISCO-CABLE-WIDEBAND-MIB

Sets the polling interval for calculating the utilization of an RF channel by using the **ccwbRFChanUtilInterval** object.

### DOCS-QOS-MIB

- Sets the load and utilization of both upstream and downstream physical channels through the **docsIfCmtsChannelUtilizationInterval** object. This information may be used for capacity planning and incident analysis, and may be particularly helpful in provisioning high value QoS.
- Displays information about all service flows (DOCSIS 1.1 service flows only) including multicast service flow is maintained in the **docsQosServiceFlowLogTable** in DOCS-QOS-MIB, **docsIetfQosServiceFlowLogTable** in DOCS-IETF-QOS-MIB, and **docsQos3ServiceFlowLogTable** in DOCS-QOS3-MIB.

To view information about deleted service flows, enable logging of deleted service flows using the **cable sflog** global configuration command.

## Benefits

The usage-based billing feature provides the following benefits to cable service providers and their partners and customers:

- Allows service providers to integrate their billing applications for DOCSIS services with their other XML-capable billing applications.
- Standards-based approach that supports existing networks and services, such as DOCSIS and PacketCable, and is easily extensible to support future services as they are supported on the Cisco CMTS.

## How to Configure the Usage-based Billing Feature

This section describes the following tasks that are required to implement the Usage-based Billing feature:



## Enabling Usage-based Billing Feature File Mode Using CLI Commands

This section describes how to enable and configure the Usage-based Billing feature so that it operates in file mode, where it writes the billing record files to a local file system. The billing application must then log into the Cisco CMTS and retrieve the billing record files on a regular basis.

### Procedure

|        | Command or Action                                                                                                                                                                                                                                  | Purpose                                                                                                                                                                                                                                                              |
|--------|----------------------------------------------------------------------------------------------------------------------------------------------------------------------------------------------------------------------------------------------------|----------------------------------------------------------------------------------------------------------------------------------------------------------------------------------------------------------------------------------------------------------------------|
| Step 1 | <p><b>enable</b></p> <p><b>Example:</b></p> <pre>Router&gt; enable</pre> <p><b>Example:</b></p> <pre>Router#</pre>                                                                                                                                 | Enables privileged EXEC mode. Enter your password if prompted.                                                                                                                                                                                                       |
| Step 2 | <p><b>configure terminal</b></p> <p><b>Example:</b></p> <pre>Router# configure terminal</pre> <p><b>Example:</b></p> <pre>Router(config)#</pre>                                                                                                    | Enters global configuration mode.                                                                                                                                                                                                                                    |
| Step 3 | <p><b>cable metering filesystem <i>filesys</i> [flow-aggregate] [cpe-list-suppress] [full-records]</b></p> <p><b>Example:</b></p> <pre>Router(config)# cable metering filesystem harddisk:</pre> <p><b>Example:</b></p> <pre>Router(config)#</pre> | <p>Enables the Usage-based Billing feature for file mode and configures it.</p> <p>The system will write the billing records on this file system using a file name that contains the hostname of the router followed by a timestamp when the record was written.</p> |
| Step 4 | <p><b>snmp-server enable traps cable metering</b></p> <p><b>Example:</b></p> <pre>Router(config)# snmp-server enable traps cable metering</pre> <p><b>Example:</b></p> <pre>Router(config)#</pre>                                                  | (Optional) Enables SNMP traps for usage-based billing events. Traps are sent when a new billing record is available, or when the system encountered a failure (such as insufficient disk space) in writing the new billing record.                                   |

|               | Command or Action                                                                                                                                                                                                        | Purpose                                                                                                                                         |
|---------------|--------------------------------------------------------------------------------------------------------------------------------------------------------------------------------------------------------------------------|-------------------------------------------------------------------------------------------------------------------------------------------------|
| <b>Step 5</b> | <p><b>cable sflog max-entry</b> <i>number entry-duration time</i></p> <p><b>Example:</b></p> <pre>Router(config)# cable sflog max-entry 2000 entry-duration 7200</pre> <p><b>Example:</b></p> <pre>Router(config)#</pre> | (Optional) Enables logging for deleted SNMP service flows, which allows the billing feature to include information about deleted service flows. |
| <b>Step 6</b> | <p><b>cable metering source-interface</b> <i>interface</i></p> <p><b>Example:</b></p> <pre>Router(config)# cable metering source-interface loopback100</pre> <p><b>Example:</b></p> <pre>Router(config)#</pre>           | (Optional) Enables specification of the source-interface for the billing packets, usually a loopback interface.                                 |
| <b>Step 7</b> | <p><b>end</b></p> <p><b>Example:</b></p> <pre>Router(config)# end</pre> <p><b>Example:</b></p> <pre>Router#</pre>                                                                                                        | Exits global configuration mode and returns to privileged EXEC mode.                                                                            |

## Enabling Usage-based Billing Feature File Mode Using SNMP Commands

This section describes how to enable and configure the Usage-based Billing feature so that it operates in file mode and writes the billing record files to a local file system. The billing application must then log into the Cisco CMTS and retrieve the billing record files on a regular basis.

To configure the Cisco CMTS for Usage-based Billing feature in file mode, you must set a number of objects in the CISCO-CABLE-METERING-MIB.

In addition, to include information about deleted service flows in the billing records (supported for DOCSIS 1.1 service flows), you must enable the logging of deleted service flows, using the **cable sflog** global configuration command.

Table 359: SNMP Objects to be Configured for File Mode

| Object                    | Type          | Description                                                                                                                                                                                                                                                                                                                                                                                                                                                                                                                                                                                                                                                                                                                                      |
|---------------------------|---------------|--------------------------------------------------------------------------------------------------------------------------------------------------------------------------------------------------------------------------------------------------------------------------------------------------------------------------------------------------------------------------------------------------------------------------------------------------------------------------------------------------------------------------------------------------------------------------------------------------------------------------------------------------------------------------------------------------------------------------------------------------|
| ccmtrCollectionType       | Integer       | Enables or disables the Usage-based Billing feature. The valid values are: <ul style="list-style-type: none"> <li>• 1—none. The Usage-based Billing feature is disabled (default).</li> <li>• 2—local. The Usage-based Billing feature is enabled and configured for file mode.</li> <li>• 3—stream. The Usage-based Billing feature is enabled and configured for streaming mode.</li> </ul> Set ccmtrCollectionType to 2 (local) to enable the feature for file mode.                                                                                                                                                                                                                                                                          |
| ccmtrCollectionFilesystem | DisplayString | Specifies the file system where the billing record file should be written. This object has a maximum length of 25 characters and must specify a valid file system on the router (such as slot0, disk1, or flash). <p><b>Note</b> The Cisco CMTS writes the billing records to this file system using a file name that consists of the router’s hostname followed by a timestamp when the record was written.</p>                                                                                                                                                                                                                                                                                                                                 |
| ccmtrCollectionCpeList    | TruthValue    | (Optional) Indicates whether IP addresses for customer premises equipment (CPE) devices are omitted from the billing records, so as to reduce the size of the billing records and to improve performance. The valid values are the following: <ul style="list-style-type: none"> <li>• true—CPE information is present (default).</li> <li>• false—CPE information is omitted.</li> </ul> <p><b>Note</b> When set to true, a maximum of 5 CPE IP addresses for each cable modem.</p>                                                                                                                                                                                                                                                             |
| ccmtrCollectionAggregate  | TruthValue    | (Optional) Indicates whether all information for an individual cable modem is combined into one record. Separate counters are maintained for upstream and downstream traffic, but those counters include all service flows in that direction. The valid values are as follows: <ul style="list-style-type: none"> <li>• true—All service flow information for each cable modem is aggregated into a single billing record. In this configuration, the service flow ID (SFID) for the billing record is set to 0 and the service class name (SCN) is blank.</li> <li>• false—Information for each cable modem is not aggregated into a single billing record, but instead each service flow is recorded into its own record (default).</li> </ul> |
| ccmtrCollectionSrcIfIndex | TruthValue    | (Optional) Specifies the source-interface for the billing packets.                                                                                                                                                                                                                                                                                                                                                                                                                                                                                                                                                                                                                                                                               |



**Note** The following steps use the standard SNMP commands that are available on many Unix and Linux systems. For each step, replace *ip-address* with the IP address of the Cisco CMTS, and replace *rw-community-string* with an SNMP community string that provides read-write access to the router.

**Step 1** Set the ccmtrCollectionType object to 2, to enable the Usage-based Billing feature and to configure it for file mode:

**Example:**

```
workstation# setany -v2c
ip-address rw-community-string
ccmtrCollectionType.0 -i 2
workstation#
```

**Step 2** Set the ccmtrCollectionFilesystem object to the local file system where the Cisco CMTS should write the billing records:

**Example:**

```
workstation# setany -v2c
ip-address rw-community-string
ccmtrCollectionFilesystem.0 -D disk0:
workstation#
```

**Step 3** (Optional) To omit the IP addresses of CPE devices from the billing records, set the ccmtrCollectionCpeList object to 2 (false). The default is to include the CPE information.

**Example:**

```
workstation# setany -v2c
ip-address rw-community-string
ccmtrCollectionCpeList.0 -i 2
workstation#
```

**Step 4** (Optional) To aggregate all service flow information for each cable modem in a single record, set the ccmtrCollectionAggregate object to 1 (true). The default is for each service flow to be written in a separate record:

**Example:**

```
workstation# setany -v2c
ip-address rw-community-string
ccmtrCollectionAggregate.0 -i 1
workstation#
```

**Step 5** (Optional) To specify the source-interface for the billing packets, set the ccmtrCollectionSrcIfIndex object to 1 (true). The default is for the billing packets to automatically select a source-interface.

**Example:**

```
workstation# setany -v2c
ip-address rw-community-string
ccmtrCollectionSrcIfIndex.0 -i 1
workstation#
```

## Examples for Enabling Usage Billing using SNMP Mode

The following example shows the Usage-based Billing feature being configured using SNMP commands. The following display shows that a Cisco CMTS router at IP address 10.8.8.21 is configured with the default configuration (the Usage-based Billing feature is disabled):

```
workstation# getmany -v2c 10.8.8.21 rw-string ciscoCableMeteringMIB

ccmtrCollectionType.0 = none(1)
ccmtrCollectionFilesystem.0 =
ccmtrCollectionCpeList.0 = true(1)
ccmtrCollectionAggregate.0 = false(2)
ccmtrCollectionStatus.0 = 0
ccmtrCollectionDestination.0 =
ccmtrCollectionTimestamp.0 = 00 00 00 00 00 00 00 00
ccmtrCollectionNotifEnable.0 = true(1)
workstation#
```

The following SNMP commands are then given to enable the Usage-based Billing feature and to configure it for file mode:

```
workstation# setany -v2c 10.8.8.21 rw-string ccmtrCollectionType.0 -i 2
workstation# setany -v2c 10.8.8.21 rw-string
ccmtrCollectionFilesystem
.0 -D disk1:
workstation#
```

These commands add the following line to the router's running configuration file:

```
Router# show running-config | include metering

cable metering filesystem disk1:
Router#
```

The following SNMP display shows the new configuration, after the Cisco CMTS has successfully written a billing record:

```
workstation# getmany -v2c 10.8.8.21 rw-string ciscoCableMeteringMIB

ccmtrCollectionType.0 = local(2)
ccmtrCollectionFilesystem.0 = disk1:
ccmtrCollectionCpeList.0 = true(1)
ccmtrCollectionAggregate.0 = false(2)
ccmtrCollectionStatus.0 = success(1)
ccmtrCollectionDestination.0 = disk1:UBR7246.cisco.com-20030925-185827
ccmtrCollectionTimestamp.0 = 07 d3 09 19 12 3a 1c 00
ccmtrCollectionNotifEnable.0 = true(1)
workstation#
```

## Enabling Usage-based Billing Feature Streaming Mode Using CLI Commands

This section describes how to enable and configure the Usage-based Billing feature so that it operates in streaming mode, where it regularly transmits the billing records to an external server for use by the billing application.

**Procedure**

|               | <b>Command or Action</b>                                                                                                                                                                                                                                                                                                                                  | <b>Purpose</b>                                                                                                                                                                                                                     |
|---------------|-----------------------------------------------------------------------------------------------------------------------------------------------------------------------------------------------------------------------------------------------------------------------------------------------------------------------------------------------------------|------------------------------------------------------------------------------------------------------------------------------------------------------------------------------------------------------------------------------------|
| <b>Step 1</b> | <p><b>enable</b></p> <p><b>Example:</b></p> <pre>Router&gt; enable</pre> <p><b>Example:</b></p> <pre>Router#</pre>                                                                                                                                                                                                                                        | Enables privileged EXEC mode. Enter your password if prompted.                                                                                                                                                                     |
| <b>Step 2</b> | <p><b>configure terminal</b></p> <p><b>Example:</b></p> <pre>Router# configure terminal</pre> <p><b>Example:</b></p> <pre>Router(config)#</pre>                                                                                                                                                                                                           | Enters global configuration mode.                                                                                                                                                                                                  |
| <b>Step 3</b> | <p><b>cable metering destination</b> <i>ip-address port [ip-address2 port2 ] retries minutes {non-secure   secure} [flow-aggregate] [cpe-list-suppress] [full-records]</i></p> <p><b>Example:</b></p> <pre>Router(config)# cable metering destination 10.10.21.3 5300 10.10.21.4 5300 2 30 secure</pre> <p><b>Example:</b></p> <pre>Router(config)#</pre> | Enables the Usage-based Billing feature for streaming mode and configures it with the following parameters:                                                                                                                        |
| <b>Step 4</b> | <p><b>snmp-server enable traps cable metering</b></p> <p><b>Example:</b></p> <pre>Router(config)# snmp-server enable traps cable metering</pre> <p><b>Example:</b></p> <pre>Router(config)#</pre>                                                                                                                                                         | (Optional) Enables SNMP traps for usage-based billing events. Traps are sent when a new billing record is available, or when the system encountered a failure (such as insufficient disk space) in writing the new billing record. |
| <b>Step 5</b> | <p><b>cable sflog max-entry</b> <i>number entry-duration time</i></p> <p><b>Example:</b></p> <pre>Router(config)# cable sflog max-entry 2000 entry-duration 7200</pre> <p><b>Example:</b></p> <pre>Router(config)#</pre>                                                                                                                                  | (Optional) Enables logging for deleted SNMP service flows, which allows the billing feature to include information about deleted service flows.                                                                                    |

|        | Command or Action                                                                                                                                                                                              | Purpose                                                                                                         |
|--------|----------------------------------------------------------------------------------------------------------------------------------------------------------------------------------------------------------------|-----------------------------------------------------------------------------------------------------------------|
| Step 6 | <p><b>cable metering source-interface</b> <i>interface</i></p> <p><b>Example:</b></p> <pre>Router(config)# cable metering source-interface loopback100</pre> <p><b>Example:</b></p> <pre>Router(config)#</pre> | (Optional) Enables specification of the source-interface for the billing packets, usually a loopback interface. |
| Step 7 | <p><b>end</b></p> <p><b>Example:</b></p> <pre>Router(config)# end</pre> <p><b>Example:</b></p> <pre>Router#</pre>                                                                                              | Exits global configuration mode and returns to privileged EXEC mode.                                            |

## Enabling Usage-based Billing Feature Streaming Mode Using SNMP Commands

This section describes how to use SNMP commands to enable and configure the Usage-based Billing feature so that it operates in streaming mode, where it regularly transmits the billing records to an external server for use by the billing application.

To configure the Cisco CMTS for Usage-based Billing feature in streaming mode, you must set a number of objects in the CISCO-CABLE-METERING-MIB.



**Note** In addition, to include information about deleted service flows (DOCSIS 1.1 service flows only) in the billing records, you must enable the logging of deleted service flows, using the **cable sflog** global configuration command. See the *Cisco IOS CMTS Cable Command Reference Guide* on Cisco.com:

[Cisco CMTS Cable Command Reference](#)

Table 360: SNMP Objects to be Configured for Streaming Mode

| Object            | Type    | Description                                                                                                                                                                                                                                                                                                                                                                                                                                                                         |
|-------------------|---------|-------------------------------------------------------------------------------------------------------------------------------------------------------------------------------------------------------------------------------------------------------------------------------------------------------------------------------------------------------------------------------------------------------------------------------------------------------------------------------------|
| ccmCollectionType | Integer | <p>Enables or disables the Usage-based Billing feature. The valid values are:</p> <ul style="list-style-type: none"> <li>1—none. The Usage-based Billing feature is disabled (default).</li> <li>2—local. The Usage-based Billing feature is enabled and configured for file mode.</li> <li>3—stream. The Usage-based Billing feature is enabled and configured for streaming mode.</li> </ul> <p>Set ccmCollectionType to 3 (stream) to enable the feature for streaming mode.</p> |

| Object                                                                                                                                                                                                                                                      | Type            | Description                                                                                                                                                                                                                                                                                                                                                                                                                                                                                                         |
|-------------------------------------------------------------------------------------------------------------------------------------------------------------------------------------------------------------------------------------------------------------|-----------------|---------------------------------------------------------------------------------------------------------------------------------------------------------------------------------------------------------------------------------------------------------------------------------------------------------------------------------------------------------------------------------------------------------------------------------------------------------------------------------------------------------------------|
| ccmCollectionIpAddress                                                                                                                                                                                                                                      | InetAddress     | IP address for the external collection server. This value must be specified.                                                                                                                                                                                                                                                                                                                                                                                                                                        |
| ccmCollectionPort                                                                                                                                                                                                                                           | Unsigned32      | TCP port number at the external collection server to which the billing records should be sent. The valid range is 0 to 65535, but you should not specify a port in the well-known range of 0 to 1024. This value must be specified.                                                                                                                                                                                                                                                                                 |
| <p><b>Note</b> You can configure the ccmCollectionIpAddress and ccmCollectionPort objects twice, to specify a primary collection server and a secondary collection server.</p>                                                                              |                 |                                                                                                                                                                                                                                                                                                                                                                                                                                                                                                                     |
| ccmCollectionIpAddrType                                                                                                                                                                                                                                     | InetAddressType | (Optional) Type of IP address being used for the collection server. The only valid value is ipv4, which is the default value.                                                                                                                                                                                                                                                                                                                                                                                       |
| ccmCollectionInterval                                                                                                                                                                                                                                       | Unsigned32      | (Optional) Specifies how often, in minutes, the billing records are streamed to the external server. The valid range is 2 to 1440 minutes (24 hours), with a default of 30 minutes. (We recommend a minimum interval of 30 minutes.)                                                                                                                                                                                                                                                                                |
| ccmCollectionRetries                                                                                                                                                                                                                                        | Unsigned32      | (Optional) Specifies the number of retry attempts that the CMTS will make to establish a secure connection with the external server before using the secondary server (if configured) and sending an SNMP trap about the failure. The valid range for <i>n</i> is 0 to 5, with a default of 0.                                                                                                                                                                                                                      |
| <p><b>Note</b> The ccmCollectionInterval and ccmCollectionRetries parameters are optional when configuring usage-based billing for streaming mode with SNMP commands, but these parameters are required when configuring the feature with CLI commands.</p> |                 |                                                                                                                                                                                                                                                                                                                                                                                                                                                                                                                     |
| ccmCollectionSecure                                                                                                                                                                                                                                         | TruthValue      | <p>(Optional) Specifies whether the Cisco CMTS should use a secure socket layer (SSL) connection when connecting with the billing application on the external server. The valid values are:</p> <ul style="list-style-type: none"> <li>• true(1)—The Cisco CMTS uses a SSL connection. This option is available only on CMTS software images that support Baseline Privacy Interface (BPI) encryption.</li> <li>• false(2)—The Cisco CMTS uses an unencrypted TCP connection. This is the default value.</li> </ul> |
| ccmCollectionCpeList                                                                                                                                                                                                                                        | TruthValue      | <p>(Optional) Indicates whether IP addresses for customer premises equipment (CPE) devices are omitted from the billing records, so as to reduce the size of the billing records and to improve performance. The valid values are the following:</p> <ul style="list-style-type: none"> <li>• true—CPE information is present (default).</li> <li>• false—CPE information is omitted.</li> </ul> <p><b>Note</b> When set to true, a maximum of 5 CPE IP addresses for each cable modem.</p>                         |



| Object                    | Type       | Description                                                                                                                                                                                                                                                                                                                                                                                                                                                                                                                                                                                                                                                                                                                                      |
|---------------------------|------------|--------------------------------------------------------------------------------------------------------------------------------------------------------------------------------------------------------------------------------------------------------------------------------------------------------------------------------------------------------------------------------------------------------------------------------------------------------------------------------------------------------------------------------------------------------------------------------------------------------------------------------------------------------------------------------------------------------------------------------------------------|
| ccmCollectionAggregate    | TruthValue | (Optional) Indicates whether all information for an individual cable modem is combined into one record. Separate counters are maintained for upstream and downstream traffic, but those counters include all service flows in that direction. The valid values are as follows: <ul style="list-style-type: none"> <li>• true—All service flow information for each cable modem is aggregated into a single billing record. In this configuration, the service flow ID (SFID) for the billing record is set to 0 and the service class name (SCN) is blank.</li> <li>• false—Information for each cable modem is not aggregated into a single billing record, but instead each service flow is recorded into its own record (default).</li> </ul> |
| ccmtrCollectionSrcIfIndex | TruthValue | (Optional) Specifies the source-interface for the billing packets.                                                                                                                                                                                                                                                                                                                                                                                                                                                                                                                                                                                                                                                                               |



**Note** The following steps use the standard SNMP commands that are available on many Unix and Linux systems. For each step, replace *ip-address* with the IP address of the Cisco CMTS, and replace *rw-community-string* with an SNMP community string that provides read-write access to the router.

**Step 1** Set the `ccmCollectionType` object to 3, to enable the Usage-based Billing feature and to configure it for streaming mode:

**Example:**

```
workstation# setany -v2c
ip-address rw-community-string
ccmCollectionType.0 -i 3
workstation#
```

**Step 2** Set the `ccmCollectionIpAddress` and `ccmCollectionPort` objects to the IP address of the external collection server and the TCP port number to which billing records should be sent:

**Example:**

```
workstation# setany -v2c
ip-address rw-community-string
ccmCollectionIpAddress.1 -o '0a 08 06 0b'

workstation# setany -v2c
ip-address rw-community-string
ccmCollectionPort.1 -g 6789

workstation#
```

**Step 3** (Optional) Set the `ccmCollectionIpAddress` and `ccmCollectionPort` objects a second time to specify the IP address and TCP port number of a second external collection server to which billing records should be sent, in the case that the Cisco CMTS cannot connect to the primary collection server:

**Example:**

```
workstation# setany -v2c
```

```
ip-address rw-community-string
ccmCollectionIpAddress.1 -o '0a 08 06 0c'

workstation# setany -v2c
ip-address rw-community-string
ccmCollectionPort.1 -g 7000

workstation#
```

- Step 4** (Optional) To change any of the other default parameters, set the appropriate objects to the desired values. For example, the following lines configure the Usage-based Billing feature for a non-secure connection, with a collection interval of 45 minutes, and a maximum number of 3 retries.

**Example:**

```
workstation# setany -v2c
ip-address rw-community-string
ccmCollectionSecure.1 -i 2
workstation# setany -v2c
ip-address rw-community-string
ccmCollectionInterval.1 -i 45
workstation# setany -v2c
ip-address rw-community-string
ccmCollectionRetries.1 -i 3
workstation#
```

- Step 5** (Optional) To omit the IP addresses of CPE devices from the billing records, set the `ccmCollectionCpeList` object to 2 (false). The default is to include the CPE information.

**Example:**

```
workstation# setany -v2c

ip-address rw-community-string
ccmCollectionCpeList.0 -i 2
workstation#
```

- Step 6** (Optional) To aggregate all service flow information for each cable modem in a single record, set the `ccmCollectionAggregate` object to 1 (true). The default is for each service flow to be written in a separate record:

**Example:**

```
workstation# setany -v2c

ip-address rw-community-string
ccmCollectionAggregate.0 -i 1
workstation#
```

- Step 7** (Optional) To specify the source-interface for the billing packets, set the `ccmtrCollectionSrcIfIndex` object to 1 (true). The default is for the billing packets to automatically select a source-interface.

**Example:**

```
workstation# setany -v2c

ip-address rw-community-string
ccmtrCollectionSrcIfIndex.0 -i 1
workstation#
```

## Examples for SNMP Commands

The following example shows the Usage-based Billing feature being configured using SNMP commands. The following display shows that a Cisco CMTS router at IP address 10.8.8.21 is configured with the default configuration (the Usage-based Billing feature is disabled):

```
workstation# getmany -v2c 10.8.8.21 rw-string ciscoCableMeteringMIB

ccmCollectionType.0 = none(1)
ccmCollectionFilesystem.0 =
ccmCollectionCpeList.0 = true(1)
ccmCollectionAggregate.0 = false(2)
ccmCollectionStatus.0 = 0
ccmCollectionDestination.0 =
ccmCollectionTimestamp.0 = 00 00 00 00 00 00 00 00
ccmCollectionNotifEnable.0 = true(1)
workstation#
```

The following SNMP commands are then given to enable the Usage-based Billing feature and to configure it for streaming mode:

```
workstation# setany -v2c 10.8.8.21 rw-string ccmCollectionType.0 -i 3
workstation# setany -v2c 10.8.8.21 rw-string ccmCollectionIpAddress.1 -o '0a 08 06 0b'

workstation# setany -v2c 10.8.8.21 rw-string ccmCollectionPort.1 -g 6789

workstation# setany -v2c 10.8.8.21 rw-string ccmCollectionSecure.1 -i 2
workstation# setany -v2c 10.8.8.21 rw-string ccmCollectionRetries.1 -i 3
workstation# setany -v2c 10.8.8.21 rw-string ccmCollectionInterval.1 -i 45
workstation#
```

These commands add the following line to the router's running configuration file:

```
Router# show running-config | include metering

cable metering destination 10.8.6.11 6789 3 45 non-secure
Router#
```

The following SNMP display shows the new configuration:

```
workstation# getmany -v2c 10.8.8.21 rw-string ciscoCableMeteringMIB

ccmCollectionType.0 = stream(3)
ccmCollectionFilesystem.0 =
ccmCollectionIpAddrType.1 = ipv4(1)
ccmCollectionIpAddress.1 = 0a 08 06 0b
ccmCollectionPort.1 = 6789
ccmCollectionInterval.1 = 45
ccmCollectionRetries.1 = 3
ccmCollectionSecure.1 = false(2)
ccmCollectionRowStatus.1 = active(1)
ccmCollectionCpeList.0 = true(1)
```

```
ccmCollectionAggregate.0 = false(2)
ccmCollectionStatus.0 = 0
ccmCollectionDestination.0 =
ccmCollectionTimestamp.0 = 00 00 00 00 00 00 00 00
ccmCollectionNotifEnable.0 = true(1)
workstation#
```

## Enabling and Configuring the Secure Copy Protocol (optional)

This section describes how to configure the Cisco CMTS for the Secure Copy Protocol (SCP), which allow an external server to log in to the Cisco CMTS and copy the billing records from the Cisco CMTS to the external server.

### Procedure

|               | Command or Action                                                                                                                                                                                    | Purpose                                                                                                                                                               |
|---------------|------------------------------------------------------------------------------------------------------------------------------------------------------------------------------------------------------|-----------------------------------------------------------------------------------------------------------------------------------------------------------------------|
| <b>Step 1</b> | <p><b>enable</b></p> <p><b>Example:</b></p> <pre>Router&gt; enable</pre> <p><b>Example:</b></p> <pre>Router#</pre>                                                                                   | Enables privileged EXEC mode. Enter your password if prompted.                                                                                                        |
| <b>Step 2</b> | <p><b>configure terminal</b></p> <p><b>Example:</b></p> <pre>Router# configure terminal</pre> <p><b>Example:</b></p> <pre>Router(config)#</pre>                                                      | Enters global configuration mode.                                                                                                                                     |
| <b>Step 3</b> | <p><b>aaa new-model</b></p> <p><b>Example:</b></p> <pre>Router(config)# aaa new-model</pre> <p><b>Example:</b></p> <pre>Router(config)#</pre>                                                        | Enables the Authentication, Authorization, and Accounting (AAA) access control model.                                                                                 |
| <b>Step 4</b> | <p><b>aaa authentication login {default   list-name } method1 [method2 ...]</b></p> <p><b>Example:</b></p> <pre>Router(config)# aaa authentication login default enable</pre> <p><b>Example:</b></p> | <p>Enables AAA access control authentication at login, using the following parameters:</p> <p>Valid methods include <b>enable</b>, <b>line</b>, and <b>local</b>.</p> |

|               | Command or Action                                                                                                                                                                                                                              | Purpose                                                                                                                                                                                                                                                                                                                        |
|---------------|------------------------------------------------------------------------------------------------------------------------------------------------------------------------------------------------------------------------------------------------|--------------------------------------------------------------------------------------------------------------------------------------------------------------------------------------------------------------------------------------------------------------------------------------------------------------------------------|
|               | Router(config)#                                                                                                                                                                                                                                |                                                                                                                                                                                                                                                                                                                                |
| <b>Step 5</b> | <p><b>aaa authorization exec</b> {default   list-name } method1 [method2 ...]</p> <p><b>Example:</b></p> <pre>Router(config)# aaa authorization exec default local</pre> <p><b>Example:</b></p> <pre>Router(config)#</pre>                     | <p>Configures the CMTS to allow users to run an EXEC shell and access the CLI to run the Secure Copy commands.</p> <p>Valid methods include <b>local</b>.</p>                                                                                                                                                                  |
| <b>Step 6</b> | <p><b>username name privilege level password encryption-type password</b></p> <p><b>Example:</b></p> <pre>Router(config)# username billingapp privilege 15 password 7 billing-password</pre> <p><b>Example:</b></p> <pre>Router(config)#</pre> | <p>(Optional) Creates a user account for login access and specifies the privilege level and password for that account:</p> <p><b>Note</b> This step is optional but for the purposes of security and management, Cisco recommends creating a unique account for the billing application to use when logging into the CMTS.</p> |
| <b>Step 7</b> | <p><b>ip ssh time-out seconds</b></p> <p><b>Example:</b></p> <pre>Router(config)# ip ssh time-out 120</pre> <p><b>Example:</b></p> <pre>Router(config)#</pre>                                                                                  | <p>Enables Secure Shell (SSH) access on the Cisco CMTS, which is required for SCP use. The <i>seconds</i> parameter specifies the maximum time allowed for SSH authentication, in seconds, with a valid range of 0 to 120 seconds, with a default of 120 seconds.</p>                                                          |
| <b>Step 8</b> | <p><b>ip ssh authentication-retries n</b></p> <p><b>Example:</b></p> <pre>Router(config)# ip ssh authentication-retries 3</pre> <p><b>Example:</b></p> <pre>Router(config)#</pre>                                                              | <p>Specifies the maximum number of login attempts a user is allowed before the router disconnects the SSH session. The valid range is 1 to 5, with a default of 3 attempts.</p>                                                                                                                                                |
| <b>Step 9</b> | <p><b>ip scp server enable</b></p> <p><b>Example:</b></p> <pre>Router(config)# ip scp server enable</pre> <p><b>Example:</b></p> <pre>Router(config)#</pre>                                                                                    | <p>Enables SCP access on the Cisco CMTS.</p>                                                                                                                                                                                                                                                                                   |

|         | Command or Action                                                       | Purpose                                                              |
|---------|-------------------------------------------------------------------------|----------------------------------------------------------------------|
| Step 10 | <b>end</b><br><b>Example:</b><br><pre>Router(config)# end Router#</pre> | Exits global configuration mode and returns to privileged EXEC mode. |

## Configuring the Cisco CMTS for SSL Operation

This section describes the procedures to configure the Cisco CMTS for secure socket layer (SSL) operation, so that the Usage-based Billing feature can use an SSL connection to transfer the billing record files in streaming mode.



**Note** This procedure is required only when using the **secure** option with the **cable metering destination** command.

### Prerequisites for CA

- The billing application server must be configured for SSL operations.
- A Certificate Authority (CA) must be configured to provide the required digital certificates to the billing application and Cisco CMTS router. The CA can be a public CA, such as Verisign, or a server on your private management network that is running software such as the Cisco Provisioning Center (CPC).

#### SUMMARY STEPS

To prepare the Cisco CMTS router for SSL operation, you must perform the following configuration steps:

- Configuring the router’s host name and IP domain name, if not already done.
- Generating an RSA key pair.
- Declaring a Certification Authority.
- Configuring a Root CA (Trusted Root).
- Authenticating the CA.
- Requesting the Certificates.

For the detailed steps in performing these procedures, see the [Configuring Certification Authority Interoperability](#)

## Retrieving Records from a Cisco CMTS in File Mode

When the Usage-based Billing feature is enabled and configured for File mode, the billing application server must regularly retrieve the billing records from the Cisco CMTS. This is typically done by a script that either logs in to the Cisco CMTS and uses CLI commands to transfer the file, or by a script that uses SNMP commands to transfer the file.

When using CLI commands, the procedure is typically as follows:

1. The billing application server receives an SNMP trap from the Cisco CMTS when a billing record is written. This notification contains the file name of the billing record that should be retrieved.

2. The billing application server starts a custom-written script to retrieve the billing record. This script would do one of the following:
  - a. If using CLI commands, the script logs in to the Cisco CMTS using a telnet connection, and then transfers the billing record to the billing application server, using the **copy** CLI command. The transfer can be done using either the Secure Copy Protocol (SCP) or the Trivial File Transfer Protocol (TFTP).



---

**Note** You could also use the File Transfer Protocol (FTP) to transfer files from the Cisco CMTS to an external FTP server, but this is not recommended, because the FTP protocol transmits the login username and password in cleartext.

---

1. If using SNMP commands, the script sets the ciscoFlashCopyEntry objects in the CISCO-FLASH-MIB to transfer the billing record to the application server, using TFTP.
2. After transferring the billing record, the script deletes it on the Cisco CMTS file system, so that the Cisco CMTS can begin writing a new billing record.

The following sections show examples of how this can be done, using each method.



---

**Tip** The following examples are given for illustration only. Typically, these commands would be incorporated in automated scripts that would retrieve the billing records.

---

## Using SCP

To transfer billing records using SCP, you must first enable and configure the router for SCP operation, using the procedure given in the “Enabling and Configuring Secure Copy (optional)” section on page 21 . Then, the application server must log in to the Cisco CMTS and use the **copy** command at the privileged EXEC prompt. The **copy** command needs to specify the location of the billing record on the local filesystem and the destination server for the SCP transfer.

The following example shows a typical session where a billing record on slot0 is transferred to an FTP server with the hostname of billserver.mso-example.com:

```
CMTS01# copy slot0:CMTS01_20030211-155025 scp://billingapp-server.mso-example.com/
Address or name of remote host [billingapp-server.mso-example.com]?
Destination username [billing-app]?
Destination filename [CMTS01_20030211-155025]?
Writing CMTS01_20030211-155025
Password: billing-password

!!
[OK - 1403352/1024 bytes]
1403352 bytes copied in 17.204 secs (85631 bytes/sec)
CMTS01# delete slot0:CMTS01_20030211-155025

CMTS01# squeeze slot0:

CMTS01#
```



---

**Note** The billing application must delete the billing record after it has been successfully transferred, so that the Cisco CMTS can write the next record. The **squeeze** command frees up the deleted disk space on Flash Memory and old-style PCMCIA cards (bootflash, flash, slot0, slot1). It is not needed on the newer ATA-style PCMCIA cards (disk0, disk1, disk2). However, because the **squeeze** command takes several seconds to complete, it should be given only when insufficient disk space exists for a new billing record. To avoid this problem, Cisco recommends using a 64 MB (or larger) ATA-style PCMCIA memory card, which automatically reclaims disk space for deleted files.

---

## Using TFTP

To transfer billing records using TFTP, you must first configure an external workstation to be a TFTP server. For security, the TFTP server should be isolated from the Internet or any external networks, so that only authorized TFTP clients, such as the Cisco CMTS router, can access the server.

To transfer the billing records, the application server must log in to the Cisco CMTS and use the **copy** command at the privileged EXEC prompt. The **copy** command needs to specify the location of the billing record on the local filesystem and the destination server for the TFTP transfer.

The following example shows a typical session where a billing record on slot0 is transferred to an TFTP server with the hostname of billserver.mso-example.com.

```
Router# copy slot0:CMTS01_20030211-155025 tftp://billingapp-server.mso-example.com/incoming

Address or name of remote host [billingapp-server.mso-example.com]?
Destination username [billing-app]?
Destination filename [CMTS01_20030211-155025]?
Writing CMTS01_20030211-155025
!!
[OK - 1102348/1024 bytes]
1102348 bytes copied in 14.716 secs (63631 bytes/sec)
Router# delete slot0:CMTS01_20030211-155025

Router# squeeze slot0:

Router#
```



---

**Note** The billing application must delete the billing record after it has been successfully transferred, so that the Cisco CMTS can write the next record. The **squeeze** command frees up the deleted disk space on Flash Memory and old-style PCMCIA cards (bootflash, flash, slot0, slot1). It is not needed on the newer ATA-style PCMCIA cards (disk0, disk1, disk2). However, because the **squeeze** command takes several seconds to complete, it should be given only when insufficient disk space exists for a new billing record. To avoid this problem, Cisco recommends using a 64 MB (or larger) ATA-style PCMCIA memory card, which automatically reclaims disk space for deleted files.

---

## Using SNMP

To transfer billing record file using SNMP commands, you must set a number of objects in the CISCO-FLASH-MIB to transfer the file to a TFTP server. After the file has been successfully transferred, you can then use SNMP commands to delete the billing record file.





**Note** Before proceeding with these steps, ensure that the TFTP server is properly configured to receive the billing records. At the very least, this means creating a directory that is readable and writable by all users. On some servers, the TFTP server software also requires that you create a file with the same name as the file that is to be received, and this file should also be readable and writable by all users.

To transfer a billing record file to a TFTP server, using SNMP commands, you must set a number of objects in the CISCO-FLASH-MIB.

**Table 361: Transferring a File to a TFTP Server Using SNMP Commands**

| Object                           | Type          | Description                                                                                                                                                                                                                                                                                                                                                                                                                                       |
|----------------------------------|---------------|---------------------------------------------------------------------------------------------------------------------------------------------------------------------------------------------------------------------------------------------------------------------------------------------------------------------------------------------------------------------------------------------------------------------------------------------------|
| ciscoFlashCopyEntryStatus        | RowStatus     | Status of this table entry. Typically, this object is first set to 5 (create-and-wait). Then after all other parameters are specified, it is set to Active (1) to execute the command.                                                                                                                                                                                                                                                            |
| ciscoFlashCopyCommand            | INTEGER       | Type of copy command to be performed. To copy a billing record file to a TFTP server, set this object to 3 (copyFromFlash).                                                                                                                                                                                                                                                                                                                       |
| ciscoFlashCopyServerAddress      | IpAddress     | IP address of the TFTP server.<br><b>Note</b> This parameter defaults to the broadcast address of 255.255.255.255, which means it will transfer the billing record file to the first TFTP server that responds. For security, this object should always be set to the IP address of the authorized TFTP server.                                                                                                                                   |
| ciscoFlashCopySourceName         | DisplayString | Name of the billing record file to be transferred, including the Flash device on which it is stored.                                                                                                                                                                                                                                                                                                                                              |
| ciscoFlashCopyDestinationName    | DisplayString | (Optional) Name for the billing record, including path, on the TFTP server. If not specified, the copy operation defaults to saving the billing record at the top-most directory on the TFTP server, using the original file name.<br><b>Note</b> A file with the destination file name should already exist on the TFTP server. This file should be readable and writable by all users, so that it can be replaced with the billing record file. |
| ciscoFlashCopyProtocol           | INTEGER       | (Optional) Specifies the protocol to be used when copying the file. For a TFTP transfer, set this object to 1 (tftp), which is the default.                                                                                                                                                                                                                                                                                                       |
| ciscoFlashCopyNotifyOnCompletion | Truth Value   | (Optional) Specifies whether the Cisco CMTS should generate a trap upon the completion of the copy operation. The default is false (no trap is generated).                                                                                                                                                                                                                                                                                        |

After transferring the billing records file, you must then set a number of objects in the CISCO-FLASH-MIB to delete the file, so that the Cisco CMTS can begin writing a new file. If the Flash memory is not ATA-compatible, you must also set a number of objects to squeeze the Flash memory to make the deleted space available for new files. [Table 362: Deleting a File Using SNMP Commands](#), on page 1830 describes each of these objects, and whether they are required or optional.

Table 362: Deleting a File Using SNMP Commands

| Object                             | Type          | Description                                                                                                                                                                                                                                                  |
|------------------------------------|---------------|--------------------------------------------------------------------------------------------------------------------------------------------------------------------------------------------------------------------------------------------------------------|
| ciscoFlashMiscOpCommand            | INTEGER       | Specifies the operation to be performed: <ul style="list-style-type: none"> <li>• 3—Delete the file.</li> <li>• 5—Squeeze the Flash memory, so as to recover the deleted space and make it available for new files.</li> </ul>                               |
| ciscoFlashMiscOpDestinationName    | DisplayString | When deleting a file, the name of the file to be deleted, including the name of the file system, up to a maximum of 255 characters.<br><br>When squeezing a file system, the name of the file system to be squeezed (slot0:, slot1:, flash:, or bootflash:). |
| ciscoFlashMiscOpEntryStatus        | RowStatus     | Status of this table entry. Typically, this object is first set to 5 (create-and-wait). Then after all other parameters are specified, it is set to Active (1) to execute the command.                                                                       |
| ciscoFlashMiscOpNotifyOnCompletion | TruthValue    | (Optional) Specifies whether the Cisco CMTS should generate a trap upon the completion of the operation. The default is false (no trap is generated).                                                                                                        |

DETAILED STEPS



**Note** The following steps use the standard SNMP commands that are available on many Unix and Linux systems. For each step, replace *ip-address* with the IP address of the Cisco CMTS, and replace *rw-community-string* with an SNMP community string that provides read-write access to the router.

Copying the Billing Record File to the TFTP Server

**Step 1** The script performing the copy should generate a 32-bit number to be used as the index entry for this copy command. The script can generate this number in any convenient way, so long as the index number is not currently being used for another operation.

**Step 2** Create the table entry for the copy command, by using the number that was generated in Step 1 and setting the ciscoFlashCopyEntryStatus object to the create-and-wait state (5):

**Example:**

```
workstation# setany -v2c ip-address rw-community-string ciscoFlashCopyEntryStatus.582 -i 5
workstation#
```

**Step 3** Set the ciscoFlashCopyCommand to 3 (copyFromFlash) to specify that the billing record file should be copied from the router's Flash file system:

**Example:**

```
workstation# setany -v2c ip-address rw-community-string ciscoFlashCopyCommand
.582
```

```
-i 3
workstation#
```

**Step 4** Set the `ciscoFlashCopyServerAddress` object to the IP address of the TFTP server:

**Example:**

```
workstation# setany -v2c ip-address rw-community-string ciscoFlashCopyServerAddress
.582

-a "172.20.12.193"

workstation#
```

**Step 5** Set the `ciscoFlashCopySourceName` object to the file name, including the device name, of the billing record file to be transferred:

**Example:**

```
workstation# setany -v2c ip-address rw-community-string ciscoFlashCopySourceName
.582
-D
"slot0:CMTS01_20030211-155025
"
workstation#
```

**Step 6** (Optional) To specify a specific destination on the TFTP server, set the `ciscoFlashCopyDestinationName` object to the path name and file name for the billing record file on the TFTP server. (Typically, the path name and file name should already exist on the TFTP server.)

**Example:**

```
workstation# setany -v2c ip-address rw-community-string ciscoFlashCopyDestinationName
.582
-D
"/cmts01-billing/billing-file
"
workstation#
```

**Step 7** To execute the command, set the `ciscoFlashCopyEntryStatus` object to the active state (1):

**Example:**

```
workstation# setany -v2c ip-address rw-community-string ciscoFlashCopyEntryStatus.582 -i 1

workstation#
```

**Step 8** Periodically poll the `ciscoFlashCopyStatus` object until the file transfer completes:

**Example:**

```
workstation# getmany -v2c ip-address rw-community-string ciscoFlashCopyStatus
.582
ciscoFlashCopyStatus.582 = copyInProgress(1)
workstation# getmany -v2c ip-address rw-community-string ciscoFlashCopyStatus
.582
ciscoFlashCopyStatus.582 = copyInProgress(1)
workstation# getmany -v2c ip-address rw-community-string ciscoFlashCopyStatus
.582
```

```
ciscoFlashCopyStatus.582 = copyOperationSuccess(2)
workstation#
```

If the file transfer fails, the most common status values that are reported by the `ciscoFlashCopyStatus` object are:

- 3—`copyInvalidOperation`. This indicates that the operation failed on the TFTP server, typically because the destination file name and path name do not exist on the TFTP server, or they exist but are not writable by all users.
- 5—`copyInvalidSourceName`. The file name for the billing record, as specified in `ciscoFlashCopySourceName` does not exist. Verify that you specified the correct device name and that no spaces exist in the file name.
- 6—`copyInvalidDestName`. The destination path name and file name specified in `ciscoFlashCopyDestinationName` is not accessible on the TFTP server. This could be because the path name does not exist or is not configured to allow write-access. This error could also occur if a file with the same path name and file name already exists on the TFTP server.
- 7—`copyInvalidServerAddress`. The IP address of the TFTP server specified in `ciscoFlashCopyServerAddress` is invalid, or the TFTP server is not responding.
- 14—`copyFileTransferError`. A network error occurred that prevented the file transfer from completing.

**Step 9** After the file transfer has completed successfully, set the `ciscoFlashCopyEntryStatus` object to 6 (delete) to delete the row entry for this copy command:

**Example:**

```
workstation# setany -v2c ip-address rw-community-string ciscoFlashCopyEntryStatus.582 -i 6
workstation#
```

---

### What to do next

#### Deleting the Billing Record File

## Using SNMP

After the billing record file has been successfully transferred, use the following procedure to delete the billing record on the Cisco CMTS flash file system, so that the Cisco CMTS can write the new billing record.

**Step 1** Generate another random number to be used as an index entry and configure the following objects in the `ciscoFlashMiscOpTable`:

**Example:**

```
workstation# setany -v2c ip-address rw-community-string ciscoFlashMiscOpEntryStatus
.31 -i 5

workstation# setany -v2c ip-address rw-community-string ciscoFlashMiscOpCommand
.31 -i 3
workstation# setany -v2c ip-address rw-community-string ciscoFlashMiscOpDestinationName
.31 -D
"/cmts01-billing/CMTS01_20030211-155025
"
workstation# setany -v2c ip-address rw-community-string ciscoFlashMiscOpEntryStatus
.31 -i 1

workstation#
```

**Step 2** Periodically poll the ciscoFlashMiscOpStatus object until the file transfer completes:

**Example:**

```
workstation# getmany -v2c ip-address rw-community-string ciscoFlashMiscOpStatus
.31
  ciscoFlashCopyStatus.31 = miscOpInProgress(1)
workstation# getmany -v2c ip-address rw-community-string ciscoFlashMiscOpStatus
.31
  ciscoFlashCopyStatus.582 = miscOpOperationSuccess(2)
workstation#
```

**Step 3** If the Flash memory system is not ATA-compatible (slot0:, slot1:, flash:, or bootflash:), configure the following objects in the ciscoFlashMiscOpTable to squeeze the Flash file system to recover the deleted file space:

**Example:**

```
workstation# setany -v2c ip-address rw-community-string ciscoFlashMiscOpEntryStatus
.32
-i 5

workstation# setany -v2c ip-address rw-community-string ciscoFlashMiscOpCommand
.32 -i 5
workstation# setany -v2c ip-address rw-community-string ciscoFlashMiscOpDestinationName
.32 -D slot0:
workstation# setany -v2c ip-address rw-community-string ciscoFlashMiscOpEntryStatus
.32
-i 1

workstation#
```

## Examples To Transfer Using SNMP

The following SNMP commands transfer a file named CMTS01\_20030211-155025 to a TFTP server at the IP address 10.10.31.3. After the file is successfully transferred, the row entry for this copy command is deleted.

```
workstation# setany -v2c 10.8.8.21 rw-string
  ciscoFlashCopyEntryStatus.582 -i 5

workstation# setany -v2c 10.8.8.21 rw-string
  ciscoFlashCopyCommand
.582
-i 3
workstation# setany -v2c 10.8.8.21 rw-string
  ciscoFlashCopyServerAddress
.582
-a "10.10.31.3"

workstation# setany -v2c 10.8.8.21 rw-string
  ciscoFlashCopySourceName
.582 -D
"slot0:CMTS01_20030211-155025
"
workstation# setany -v2c 10.8.8.21 rw-string
  ciscoFlashCopyDestinationName
.582 -D
"/cmts01-billing/CMTS01_20030211-155025
"
```

```

workstation# setany -v2c 10.8.8.21 rw-string
ciscoFlashCopyEntryStatus.582 -i 1

workstation# getmany -v2c 10.8.8.21 rw-string
ciscoFlashCopyStatus
.582
  ciscoFlashCopyStatus.582 = copyInProgress(1)
workstation# getmany -v2c 10.8.8.21 rw-string
ciscoFlashCopyStatus
.582
  ciscoFlashCopyStatus.582 = copyOperationSuccess(2)
workstation# setany -v2c 10.8.8.21 rw-string
ciscoFlashCopyEntryStatus.582 -i 6

workstation#

```

The following commands show a billing record file being deleted on the Cisco CMTS file system, and the deleted file space being recovered by a squeeze operation:

```

workstation# setany -v2c 10.8.8.21 rw-string
ciscoFlashMiscOpEntryStatus
.31 -i 5

workstation# setany -v2c 10.8.8.21 rw-string
ciscoFlashMiscOpCommand
.31 -i 3
workstation# setany -v2c 10.8.8.21 rw-string
ciscoFlashMiscOpDestinationName
.31 -D
"/cmts01-billing/CMTS01_20030211-155025
"
workstation# setany -v2c 10.8.8.21 rw-string
ciscoFlashMiscOpEntryStatus
.31 -i 1

workstation# getmany -v2c 10.8.8.21 rw-string
ciscoFlashMiscOpStatus
.31
  ciscoFlashCopyStatus.31 = miscOpInProgress(1)
workstation# getmany -v2c 10.8.8.21 rw-string
ciscoFlashMiscOpStatus
.31
  ciscoFlashCopyStatus.582 = miscOpOperationSuccess(2)
workstation# setany -v2c 10.8.8.21 rw-string
ciscoFlashMiscOpEntryStatus
.32 -i 5

workstation# setany -v2c 10.8.8.21 rw-string
ciscoFlashMiscOpCommand
.32 -i 5
workstation# setany -v2c 10.8.8.21 rw-string
ciscoFlashMiscOpDestinationName
.32 -D slot0:
workstation# setany -v2c 10.8.8.21 rw-string
ciscoFlashMiscOpEntryStatus
.32 -i 1

workstation#

```

## Disabling the Usage-based Billing Feature

This section describes how to disable the Usage-based Billing. Giving this command immediately stops the collection of billing information. If a billing record is currently written or being streamed to an external server, the CMTS completes the operation before disabling the usage-based billing feature.

### Procedure

|        | Command or Action                                                                                                                                                                                       | Purpose                                                                                               |
|--------|---------------------------------------------------------------------------------------------------------------------------------------------------------------------------------------------------------|-------------------------------------------------------------------------------------------------------|
| Step 1 | <p><b>enable</b></p> <p><b>Example:</b></p> <pre>Router&gt; enable</pre> <p><b>Example:</b></p> <pre>Router#</pre>                                                                                      | Enables privileged EXEC mode. Enter your password if prompted.                                        |
| Step 2 | <p><b>configure terminal</b></p> <p><b>Example:</b></p> <pre>Router# configure terminal</pre> <p><b>Example:</b></p> <pre>Router(config)#</pre>                                                         | Enters global configuration mode.                                                                     |
| Step 3 | <p><b>no cable metering</b></p> <p><b>Example:</b></p> <pre>Router(config)# no cable metering</pre> <p><b>Example:</b></p> <pre>Router(config)#</pre>                                                   | Immediately disables the Usage-based Billing feature and stops the collection of billing information. |
| Step 4 | <p><b>no snmp-server enable traps cable metering</b></p> <p><b>Example:</b></p> <pre>Router(config)# no snmp-server enable traps cable metering</pre> <p><b>Example:</b></p> <pre>Router(config)#</pre> | (Optional) Disables SNMP traps for usage-based billing events.                                        |
| Step 5 | <p><b>no cable sflog</b></p> <p><b>Example:</b></p> <pre>Router(config)# no cable sflog</pre> <p><b>Example:</b></p>                                                                                    | (Optional) Disables the logging of deleted service flows.                                             |

|               | Command or Action                                                                                                                                                                       | Purpose                                                                   |
|---------------|-----------------------------------------------------------------------------------------------------------------------------------------------------------------------------------------|---------------------------------------------------------------------------|
|               | Router(config)#                                                                                                                                                                         |                                                                           |
| <b>Step 6</b> | <p><b>no cable metering source-interface</b></p> <p><b>Example:</b></p> <pre>Router(config)# no cable metering source-interface</pre> <p><b>Example:</b></p> <pre>Router(config)#</pre> | (Optional) Disables a specified source-interface for the billing packets. |
| <b>Step 7</b> | <p><b>exit</b></p> <p><b>Example:</b></p> <pre>Router(config)# exit</pre> <p><b>Example:</b></p> <pre>Router#</pre>                                                                     | Exits global configuration mode.                                          |

## Configuring Certified SSL Servers for Usage-Based Billing

Cisco introduces adds support for the Secure Socket Layer (SSL) Server, used with the usage-based billing feature of the Cisco CMTS. Usage-based billing implements the DOCSIS Subscriber Account Management Interface Specification (SAMIS) format.

This new capability enables the configuration of the SSL server between the Cisco CMTS and a collection server. Certificate creation steps and **debug** commands are added or enhanced to support the SSL Server and certificates. This section describes general steps.

Refer also to the [Configuring the Cisco CMTS for SSL Operation, on page 1826](#) section.

### Generating SSL Server Certification

These general steps describe the creation and implementation of certification for the Secure Socket Layer (SSL) Server.

1. Generate the CA key.
2. Set up the open SSL environment, to include directory and sub-directory.
3. Copy files to the appropriate directories.
4. Generate the SSL Server certification request.
5. Grant the SSL Server certification request.
6. Convert the SSL Server certification to DER format.
7. Copy the SSL certification to Bootflash memory (write mem).
8. Start the SSL server.



## Configuring and Testing the Cisco CMTS for Certified SSL Server Support

Perform the following steps to configure the Cisco router to support the SSL Server and certification.

### Procedure

|               | Command or Action                                                                                                     | Purpose                                                                                                                                                                                                                                                                                                                                                                     |
|---------------|-----------------------------------------------------------------------------------------------------------------------|-----------------------------------------------------------------------------------------------------------------------------------------------------------------------------------------------------------------------------------------------------------------------------------------------------------------------------------------------------------------------------|
| <b>Step 1</b> | <p><b>enable</b></p> <p><b>Example:</b></p> <pre>Router&gt; enable</pre>                                              | <p>Enables privileged EXEC mode.</p> <ul style="list-style-type: none"> <li>• Enter your password if prompted.</li> </ul>                                                                                                                                                                                                                                                   |
| <b>Step 2</b> | <p><b>configure terminal</b></p> <p><b>Example:</b></p> <pre>Router# configure terminal</pre>                         | <p>Enters global configuration mode.</p>                                                                                                                                                                                                                                                                                                                                    |
| <b>Step 3</b> | <p><b>ip domain name <i>domain</i></b></p> <p><b>Example:</b></p> <pre>Router(config)# ip domain name Cisco.com</pre> | <p>Defines a default domain name that the Cisco IOS software uses to complete unqualified host names (names without a dotted-decimal domain name). Do not include the initial period that separates an unqualified name from the domain name.</p> <p><b>Note</b> See the <a href="#">Domain Name System (DNS)</a> document on Cisco.com for additional DNS information.</p> |
| <b>Step 4</b> | <p><b>crypto key generate rsa</b></p> <p><b>Example:</b></p> <pre>Router(config)# crypto key generate rsa</pre>       | <p>Generates RSA key pairs.</p>                                                                                                                                                                                                                                                                                                                                             |
| <b>Step 5</b> | <p>Ctrl-Z</p> <p><b>Example:</b></p> <pre>Router(config)# Ctrl-Z</pre> <p><b>Example:</b></p> <pre>Router#</pre>      | <p>Returns to privileged EXEC mode.</p>                                                                                                                                                                                                                                                                                                                                     |
| <b>Step 6</b> | <p><b>test cable read certificate</b></p> <p><b>Example:</b></p> <pre>Router# test cable read certificate</pre>       | <p>Verifies the certificate is valid and operational on the Cisco CMTS.</p>                                                                                                                                                                                                                                                                                                 |
| <b>Step 7</b> | <p><b>show crypto ca certificate</b></p> <p><b>Example:</b></p> <pre>Router# show crypto ca certificate</pre>         | <p>Displays the available certificates on the Cisco CMTS.</p>                                                                                                                                                                                                                                                                                                               |

|                | Command or Action                                                                                                                                               | Purpose                                                                                 |
|----------------|-----------------------------------------------------------------------------------------------------------------------------------------------------------------|-----------------------------------------------------------------------------------------|
| <b>Step 8</b>  | <b>configure terminal</b><br><b>Example:</b><br>Router# configure terminal<br><b>Example:</b><br>Router(config)#                                                | Enters global configuration mode.                                                       |
| <b>Step 9</b>  | <b>cable metering destination ip-addr num-1 num-2 num-3 secure</b><br><b>Example:</b><br>Router(config)# cable metering destination 1.7.7.7<br>6789 0 15 secure | Defines the destination IP address for cable metering, to be used with the certificate. |
| <b>Step 10</b> | <b>test cable metering</b><br><b>Example:</b><br>Router# test cable metering                                                                                    | Tests cable metering in light of the supported SSL server and metering configuration.   |

## Monitoring the Usage-based Billing Feature

To display the most current billing record, use the **show cable metering-status** command. The following example shows typical output when usage-based billing is configured to write the billing records to a local file system:

```
CMTS01# show cable metering-status
destination                               complete-time   flow  cpe    status
   aggr suppress
disk0:R7519-UBR7246-20000308-004428 Jun 12 09:33:05 No    No    success
CMTS01#
```

The following example shows a typical output for the **show cable metering-status** command when usage-based billing is configured to stream the billing records to an external server:

```
Router# show cable metering-status
destination                               complete-time   flow cpe  full status
   aggr supp rec
10.11.37.2 :1234                          Jun 12 09:33:05 No   No  No success
Router#
```

The following example shows a typical output for the **show cable metering-status** command using verbose option:

```
Router# show cable metering-status verbose
Last export status
```

```

Destination : disk0:sunethra10k-20070129-190423
Complete Time : Jan29 19:04:38
Flow Aggregate : No
Full records : No
Cpe list suppression : No
Source interface : FastEthernet0/0/0
Status of last export : success
Current export status : In progress
    
```

The following example shows a typical output for the **show cable metering-status** command when usage-based billing is configured to use the IPDR Exporter to stream the billing records to an external server:

```

Router# show cable metering-status
destination          complete-time  flow  cpe  full  status
          aggr  supp  rec
IPDR_Session2      Apr12 16:51:15  No    No   No    success
    
```

The following example shows a typical output for the verbose form of the **show cable metering-status** command when usage-based billing is configured to use the IPDR Exporter to stream the billing records to an external server:

```

Router# show cable metering-status
  verbose

Last export status
Destination          : IPDR_Session2
Complete Time       : Apr12 16:51:15
Flow Aggregate      : No
Full records        :No
Cpe list suppression : No
Source interface    : Not defined
Status of last export : success
    
```



---

**Note** If the **show cable metering-status** command displays the status of a streaming operation as “success” but the records were not received on the billing application server, verify that the Cisco CMTS and server are configured for the same type of communications (non-secure TCP or secure SSL). If the Cisco CMTS is configured for non-secure TCP and the server is configured for secure SSL, the Cisco CMTS transmits the billing record successfully, but the server discards all of the data, because it did not arrive in a secure SSL stream.

---



---

**Tip** The **show cable metering-status** command continues to show the status of the last billing record operation, until that billing record is deleted. If the record is not deleted, no new records are created.

---

To display information about the state of the IPDR Exporter, use the **show ipdr Exporter** command. The following example shows typical output:

```

Router#configure terminal
Router#show ipdr exporter
    
```

IPDR exporter is started.

# Configuration Examples for Usage-based Billing

This section lists the following sample configurations for the Usage-based Billing feature:

## File Mode Configuration (with Secure Copy)

The following excerpt from a configuration file shows a typical configuration for the Usage-based Billing feature when operating in file mode and enabling Secure Copy (SCP) for file transfers.

```
!
cable metering filesystem disk1:
snmp-server enable traps cable metering
...
aaa new-model
aaa authentication login default group tacacs+
aaa authorization exec default group tacacs+
username billingapp level 15 password 7 billing-password
ip ssh time-out 120
ip ssh authentication-retries 3
ip scp server enable
```

## Non-Secure Streaming Mode Configuration

The following excerpt from a configuration file shows a typical configuration for the Usage-based Billing feature when operating in streaming mode and specifying both a primary and a secondary external server. The data is sent using standard TCP packets, without any security.

```
cable metering destination 10.10.10.171 5321 10.10.10.173 5321 2 30 non-secure
snmp-server enable traps cable metering
```

The following excerpt from a configuration file shows a typical configuration for the Usage-based Billing feature when operating in streaming mode and specifying only a primary external server:

```
cable metering destination 10.10.11.181 6789 2 30 non-secure
snmp-server enable traps cable metering
```



---

**Note** You must ensure that the billing application server is configured for standard TCP communications. If the billing application server is configured for SSL communications when the Cisco CMTS is configured for standard TCP, the Cisco CMTS is able to send the billing records to the server, but the server discards all of that information because it is not arriving in a secure stream.

---

## Secure Streaming Mode Configuration

The following excerpt from a configuration file shows a typical configuration for the Usage-based Billing feature when operating in streaming mode and specifying only a primary external server. Secure socket layer (SSL) TCP connections are used to transmit the data, which requires the configuration of a digital certificate.

```

cable metering destination 10.10.11.181 6789 2 30 secure cpe-list-suppress
snmp-server enable traps cable metering
...
crypto ca trustpoint SSL-CERT
!
crypto ca certificate chain SSL-CERT
certificate ca 00
 308204A6 3082038E A0030201 02020100 300D0609 2A864886 F70D0101 04050030
 8198310B 30090603 55040613 02555331 13301106 03550408 130A4361 6C69666F
 726E6961 3111300F 06035504 07130853 616E204A 6F736531 1C301A06 0355040A
 13134369 73636F20 53797374 656D732C 20496E63 2E311130 0F060355 040B1308
 4361626C 65204255 310E300C 06035504 03130553 65656D61 3120301E 06092A86
...
 3E65DBBA 337627E8 589980D6 C8836C7E 3D3C3BC1 F21973BF 7B287D7A 13B16DA2
 02B2B180 C2A125C7 368BDA4C 0B8C81B7 7D5BEFF9 A6618140 1E95D19E BD0A84F5
 B43702AB 39B5E632 87BA36AC A3A8A827 C5BAC0F1 B24B8F4D 55615C49 5B6E4B61
 B15CC48A 8EF566C8 6E449B49 BF8E9165 317C1734 9A48A240 78A356B5 403E9E9B
 88A51F5B 0FE38CC2 F431
quit
!

```



---

**Note** You must ensure that the billing applications server is also configured for SSL communications.

---





## CHAPTER 114

# Frequency Allocation Information for the Cisco CMTS Routers

- [Frequency Allocation for the Cisco CMTS Routers, on page 1843](#)

## Frequency Allocation for the Cisco CMTS Routers

The table below provides information about the NTSC 6-MHz channel bands:

**Table 363: NTSC Cable Television Channels and Relative Frequencies in MHz**

| Channel Number | Bandwidth     | Video Carrier | Color Carrier | Audio Carrier |
|----------------|---------------|---------------|---------------|---------------|
| T 7            | 5.75 - 11.75  | 7             | 10.58         | 11.5          |
| T 8            | 11.75 - 17.75 | 13            | 16.58         | 17.5          |
| T9             | 17.75-23.75   | 19            | 22.58         | 23.5          |
| T10            | 23.75-29.75   | 25            | 28.58         | 29.5          |
| T11            | 29.75-35.75   | 31            | 34.58         | 35.5          |
| T12            | 35.75-41.75   | 37            | 40.58         | 41.5          |
| T13            | 41.75-47.75   | 43            | 46.58         | 47.5          |
| TV-IF          | 40.0-46.0     | 45.75         | 42.17         | 41.25         |
| 2-2            | 54.0-60.0     | 55.25         | 58.83         | 59.75         |
| 3-3            | 60.0-66.0     | 61.25         | 64.83         | 65.75         |
| 4-4            | 66.0-72.0     | 67.25         | 70.83         | 71.75         |
| 5-5            | 76.0-82.0     | 77.25         | 80.83         | 81.75         |
| 6-6            | 82.0-88.0     | 83.25         | 86.83         | 87.75         |

| Channel Number | Bandwidth   | Video Carrier | Color Carrier | Audio Carrier |
|----------------|-------------|---------------|---------------|---------------|
| FM             | 88.0-108.0  |               |               |               |
| A-5-95         | 90.0-96.0   | 91.25         | 94.83         | 95.75         |
| A-4-96         | 96.0-102.0  | 97.25         | 100.83        | 101.75        |
| A-3-97         | 102.0-108.0 | 103.25        | 106.83        | 107.75        |
| A-2-98         | 108.0-114.0 | 109.25        | 112.83        | 113.75        |
| A-1-99         | 114.0-120.0 | 115.25        | 118.83        | 119.75        |
| A-14           | 120.0-126.0 | 121.25        | 124.83        | 125.75        |
| B-15           | 126.0-132.0 | 127.25        | 130.83        | 131.75        |
| C-16           | 132.0-138.0 | 133.25        | 136.83        | 137.75        |
| D-17           | 138.0-144.0 | 139.25        | 142.83        | 143.75        |
| E-18           | 144.0-150.0 | 145.25        | 148.83        | 149.75        |
| F-19           | 150.0-156.0 | 151.25        | 154.83        | 155.75        |
| G-20           | 156.0-162.0 | 157.25        | 160.83        | 161.75        |
| H-21           | 162.0-168.0 | 163.25        | 166.83        | 167.75        |
| I-22           | 168.0-174.0 | 169.25        | 172.83        | 173.75        |
| 7-7            | 174.0-180.0 | 175.25        | 178.83        | 179.75        |
| 8-8            | 180.0-186.0 | 181.25        | 184.83        | 185.75        |
| 9-9            | 186.0-192.0 | 187.25        | 190.83        | 191.75        |
| 10-10          | 192.0-198.0 | 193.25        | 196.83        | 197.75        |
| 11-11          | 198.0-204.0 | 199.25        | 202.83        | 203.75        |
| 12-12          | 204.0-210.0 | 205.25        | 208.83        | 209.75        |
| 13-13          | 210.0-216.0 | 211.25        | 214.83        | 215.75        |
| J-23           | 216.0-222.0 | 217.25        | 220.83        | 221.75        |
| K-24           | 222.0-228.0 | 223.25        | 226.83        | 227.75        |
| L-25           | 228.0-234.0 | 229.25        | 232.83        | 233.75        |
| M-26           | 234.0-240.0 | 235.25        | 238.83        | 239.75        |
| N-27           | 240.0-246.0 | 241.25        | 244.83        | 245.75        |



| <b>Channel Number</b> | <b>Bandwidth</b> | <b>Video Carrier</b> | <b>Color Carrier</b> | <b>Audio Carrier</b> |
|-----------------------|------------------|----------------------|----------------------|----------------------|
| O-28                  | 246.0-252.0      | 247.25               | 250.83               | 251.75               |
| P-29                  | 252.0-258.0      | 253.25               | 256.83               | 257.75               |
| Q-30                  | 258.0-264.0      | 259.25               | 262.83               | 263.75               |
| R-31                  | 264.0-270.0      | 265.25               | 268.83               | 269.75               |
| S-32                  | 270.0-276.0      | 271.25               | 274.83               | 275.75               |
| T-33                  | 276.0-282.0      | 277.25               | 280.83               | 281.75               |
| U-34                  | 282.0-288.0      | 283.25               | 286.83               | 287.75               |
| V-35                  | 288.0-294.0      | 289.25               | 292.83               | 293.75               |
| W-36                  | 294.0-300.0      | 295.25               | 298.83               | 299.75               |
| AA-37                 | 300.0-306.0      | 301.25               | 304.83               | 305.75               |
| BB-38                 | 306.0-312.0      | 307.25               | 310.83               | 311.75               |
| CC-39                 | 312.0-318.0      | 313.25               | 316.83               | 317.75               |
| DD-40                 | 318.0-324.0      | 319.25               | 322.83               | 323.75               |
| EE-41                 | 324.0-330.0      | 325.25               | 328.83               | 329.75               |
| FF-42                 | 330.0-336.0      | 331.25               | 334.83               | 335.75               |
| GG-43                 | 336.0-342.0      | 337.25               | 340.83               | 341.75               |
| HH-44                 | 342.0-348.0      | 343.25               | 346.83               | 347.75               |
| II-45                 | 348.0-354.0      | 349.25               | 352.83               | 353.75               |
| JJ-46                 | 354.0-360.0      | 355.25               | 358.83               | 359.75               |
| KK-47                 | 360.0-366.0      | 361.25               | 364.83               | 365.75               |
| LL-48                 | 366.0-372.0      | 367.25               | 370.83               | 371.75               |
| MM-49                 | 372.0-378.0      | 373.25               | 376.83               | 377.75               |
| NN-50                 | 378.0-384.0      | 379.25               | 382.83               | 383.75               |
| OO-51                 | 384.0-390.0      | 385.25               | 388.83               | 389.75               |
| PP-52                 | 390.0-396.0      | 391.25               | 394.83               | 395.75               |
| QQ-53                 | 396.0-402.0      | 397.25               | 400.83               | 401.75               |
| RR-54                 | 402.0-408.0      | 403.25               | 406.83               | 407.75               |

| Channel Number | Bandwidth   | Video Carrier | Color Carrier | Audio Carrier |
|----------------|-------------|---------------|---------------|---------------|
| SS-55          | 408.0-414.0 | 409.25        | 412.83        | 413.75        |
| TT-56          | 414.0-420.0 | 415.25        | 418.83        | 419.75        |
| UU-57          | 420.0-426.0 | 421.25        | 424.83        | 425.75        |
| VV-58          | 426.0-432.0 | 427.25        | 430.83        | 431.75        |
| WW-59          | 432.0-438.0 | 433.25        | 436.83        | 437.75        |
| XX-60          | 438.0-444.0 | 439.25        | 442.83        | 443.75        |
| YY-61          | 444.0-450.0 | 445.25        | 448.83        | 449.75        |
| ZZ-62          | 450.0-456.0 | 451.25        | 454.83        | 455.75        |
| AAA-63         | 456.0-462.0 | 457.25        | 460.83        | 461.75        |
| BBB-64         | 462.0-468.0 | 463.25        | 466.83        | 467.75        |
| CCC-65         | 468.0-474.0 | 469.25        | 472.83        | 473.75        |
| DDD-66         | 474.0-480.0 | 475.25        | 478.83        | 479.75        |
| EEE-67         | 480.0-486.0 | 481.25        | 484.83        | 485.75        |
| FFF-68         | 486.0-492.0 | 487.25        | 490.83        | 491.75        |
| GGG-69         | 492.0-498.0 | 493.25        | 496.83        | 497.75        |
| HHH-70         | 498.0-504.0 | 499.25        | 502.83        | 503.75        |
| III-71         | 504.0-510.0 | 505.25        | 508.83        | 509.75        |
| JJJ-72         | 510.0-516.0 | 511.25        | 514.83        | 515.75        |
| KKK-73         | 516.0-522.0 | 517.25        | 520.83        | 521.75        |
| LLL-74         | 522.0-528.0 | 523.25        | 526.83        | 527.75        |
| MMM-75         | 528.0-534.0 | 529.25        | 532.83        | 533.75        |
| NNN-76         | 534.0-540.0 | 535.25        | 538.83        | 539.75        |
| OOO-77         | 540.0-546.0 | 541.25        | 544.83        | 545.75        |
| PPP-78         | 546.0-552.0 | 547.25        | 550.83        | 551.75        |
| QQQ-79         | 552.0-558.0 | 553.25        | 556.83        | 557.75        |
| RRR-80         | 558.0-564.0 | 559.25        | 562.83        | 563.75        |
| SSS-81         | 564.0-570.0 | 565.25        | 568.83        | 569.75        |

| <b>Channel Number</b> | <b>Bandwidth</b> | <b>Video Carrier</b> | <b>Color Carrier</b> | <b>Audio Carrier</b> |
|-----------------------|------------------|----------------------|----------------------|----------------------|
| TTT-82                | 570.0-576.0      | 571.25               | 574.83               | 575.75               |
| UUU-83                | 576.0-582.0      | 577.25               | 580.83               | 581.75               |
| VVV-84                | 582.0-588.0      | 583.25               | 586.83               | 587.75               |
| WWW-85                | 588.0-594.0      | 589.25               | 592.83               | 593.75               |
| XXX-86                | 594.0-600.0      | 595.25               | 598.83               | 599.75               |
| YYY-87                | 600.0-606.0      | 601.25               | 604.83               | 605.75               |
| ZZZ-88                | 606.0-612.0      | 607.25               | 610.83               | 611.75               |
| 89-89                 | 612.0-618.0      | 613.25               | 616.83               | 617.75               |
| 90-90                 | 618.0-624.0      | 619.25               | 622.83               | 623.75               |
| 91-91                 | 624.0-630.0      | 625.25               | 628.83               | 629.75               |
| 92-92                 | 630.0-636.0      | 631.25               | 634.83               | 635.75               |
| 93-93                 | 636.0-642.0      | 637.25               | 640.83               | 641.75               |
| 94-94                 | 642.0-648.0      | 643.25               | 646.83               | 647.75               |
| 100-100               | 648.0-654.0      | 649.25               | 652.83               | 653.75               |
| 101-101               | 654.0-660.0      | 655.25               | 658.83               | 659.75               |
| 102-102               | 660.0-666.0      | 661.25               | 664.83               | 665.75               |
| 103-103               | 666.0-672.0      | 667.25               | 670.83               | 671.75               |
| 104-104               | 672.0-678.0      | 673.25               | 676.83               | 677.75               |
| 105-105               | 678.0-684.0      | 679.25               | 682.83               | 683.75               |
| 106-106               | 684.0-690.0      | 685.25               | 688.83               | 689.75               |
| 107-107               | 690.0-696.0      | 691.25               | 694.83               | 695.75               |
| 108-108               | 696.0-702.0      | 697.25               | 700.83               | 701.75               |
| 109-109               | 702.0-708.0      | 703.25               | 706.83               | 707.75               |
| 110-110               | 708.0-714.0      | 709.25               | 712.83               | 713.75               |
| 111-111               | 714.0-720.0      | 715.25               | 718.83               | 719.75               |
| 112-112               | 720.0-726.0      | 721.25               | 724.83               | 725.75               |
| 113-113               | 726.0-732.0      | 727.25               | 730.83               | 731.75               |

| Channel Number | Bandwidth   | Video Carrier | Color Carrier | Audio Carrier |
|----------------|-------------|---------------|---------------|---------------|
| 114-114        | 732.0-738.0 | 733.25        | 736.83        | 737.75        |
| 115-115        | 738.0-744.0 | 739.25        | 742.83        | 743.75        |
| 116-116        | 744.0-750.0 | 745.25        | 748.83        | 749.75        |
| 117-117        | 750.0-756.0 | 751.25        | 754.83        | 755.75        |
| 118-118        | 756.0-762.0 | 757.25        | 760.83        | 761.75        |
| 119-119        | 762.0-768.0 | 763.25        | 766.83        | 767.75        |
| 120-120        | 768.0-674.0 | 769.25        | 772.83        | 773.75        |
| 121-121        | 774.0-780.0 | 775.25        | 778.83        | 779.75        |
| 122-122        | 780.0-786.0 | 781.25        | 784.83        | 785.75        |
| 123-123        | 786.0-792.0 | 787.25        | 790.83        | 791.75        |
| 124-124        | 792.0-798.0 | 793.25        | 796.83        | 797.75        |
| 125-125        | 798.0-804.0 | 799.25        | 802.83        | 803.75        |
| 126-126        | 804.0-810.0 | 805.25        | 808.83        | 809.75        |
| 127-127        | 810.0-816.0 | 811.25        | 814.83        | 815.75        |
| 128-128        | 816.0-822.0 | 817.25        | 820.83        | 821.75        |
| 129-129        | 822.0-828.0 | 823.25        | 826.83        | 827.75        |
| 130-130        | 828.0-834.0 | 829.25        | 832.83        | 833.75        |
| 131-131        | 834.0-840.0 | 835.25        | 838.83        | 839.75        |
| 132-132        | 840.0-846.0 | 841.25        | 844.83        | 845.75        |
| 133-133        | 846.0-852.0 | 847.25        | 850.83        | 851.75        |
| 134-134        | 852.0-858.0 | 853.25        | 856.83        | 857.75        |
| 135-135        | 858.0-864.0 | 859.25        | 862.83        | 863.75        |
| 136-136        | 864.0-870.0 | 865.25        | 868.83        | 869.75        |
| 137-137        | 870.0-876.0 | 871.25        | 874.83        | 875.75        |
| 138-138        | 876.0-882.0 | 877.25        | 880.83        | 881.75        |
| 139-139        | 882.0-888.0 | 883.25        | 886.83        | 887.75        |
| 140-140        | 888.0-894.0 | 889.25        | 892.83        | 893.75        |

| Channel Number | Bandwidth    | Video Carrier | Color Carrier | Audio Carrier |
|----------------|--------------|---------------|---------------|---------------|
| 141-141        | 894.0-900.0  | 895.25        | 898.83        | 899.75        |
| 142-142        | 900.0-906.0  | 901.25        | 904.83        | 905.75        |
| 143-143        | 906.0-912.0  | 907.25        | 910.83        | 911.75        |
| 144-144        | 912.0-918.0  | 913.25        | 916.83        | 917.75        |
| 145-145        | 918.0-924.0  | 919.25        | 922.83        | 923.75        |
| 146-146        | 924.0-930.0  | 925.25        | 928.83        | 929.75        |
| 147-147        | 930.0-936.0  | 931.25        | 934.83        | 935.75        |
| 148-148        | 936.0-942.0  | 937.25        | 940.83        | 941.75        |
| 149-149        | 942.0-948.0  | 943.25        | 946.83        | 947.75        |
| 150-150        | 948.0-954.0  | 949.25        | 952.83        | 953.75        |
| 151-151        | 954.0-960.0  | 955.25        | 958.83        | 959.75        |
| 152-152        | 960.0-966.0  | 961.25        | 964.83        | 965.75        |
| 153-153        | 966.0-972.0  | 967.25        | 970.83        | 971.75        |
| 154-154        | 972.0-978.0  | 973.25        | 976.83        | 977.75        |
| 155-155        | 978.0-984.0  | 979.25        | 982.83        | 983.75        |
| 156-156        | 984.0-990.0  | 985.25        | 988.83        | 989.75        |
| 157-157        | 990.0-996.0  | 991.25        | 994.83        | 995.75        |
| 158-158        | 996.0-1002.0 | 997.25        | 1000.83       | 1001.75       |

The table below provides information on the Phase Alternating Line (PAL) and Systeme Electronique Couleur Avec Memoire (SECAM) 8-MHz channel bands:

**Table 364: European Cable Television Channels and Relative Frequencies in MHz**

| Channel Number | Bandwidth | Video Carrier | Audio Carrier |
|----------------|-----------|---------------|---------------|
| 2              | 47-54     | 48.25         | 48.25         |
| 3              | 54-61     | 55.25         | 55.25         |
| 4              | 61-68     | 62.25         | 62.25         |
| S2             | 111-118   | 112.25        | 112.25        |
| S3             | 118-125   | 119.25        | 119.25        |

| Channel Number | Bandwidth | Video Carrier | Audio Carrier |
|----------------|-----------|---------------|---------------|
| S4             | 125-132   | 126.25        | 126.25        |
| S5             | 132-139   | 133.25        | 133.25        |
| S6             | 139-146   | 140.25        | 140.25        |
| S7             | 146-153   | 147.25        | 147.25        |
| S8             | 153-160   | 154.25        | 154.25        |
| S9             | 160-167   | 161.25        | 161.25        |
| S10            | 167-174   | 168.25        | 168.25        |
| 5              | 174-181   | 175.25        | 175.25        |
| 6              | 181-188   | 182.25        | 182.25        |
| 7              | 188-195   | 189.25        | 189.25        |
| 8              | 195-202   | 196.25        | 196.25        |
| 9              | 202-209   | 203.25        | 203.25        |
| 10             | 209-216   | 210.25        | 210.25        |
| 11             | 216-223   | 217.25        | 217.25        |
| 12             | 223-230   | 224.25        | 224.25        |
| S11            | 230-237   | 231.25        | 231.25        |
| S12            | 237-244   | 238.25        | 238.25        |
| S13            | 244-251   | 245.25        | 245.25        |
| S14            | 251-258   | 252.25        | 252.25        |
| S15            | 258-265   | 259.25        | 259.25        |
| S16            | 265-272   | 266.25        | 266.25        |
| S17            | 272-279   | 273.25        | 273.25        |
| S18            | 279-286   | 280.25        | 280.25        |
| S19            | 286-293   | 287.25        | 287.25        |
| S20            | 293-300   | 294.25        | 294.25        |
| S21            | 302-310   | 303.25        | 303.25        |
| S22            | 310-318   | 311.25        | 311.25        |

| Channel Number | Bandwidth | Video Carrier | Audio Carrier |
|----------------|-----------|---------------|---------------|
| S23            | 318-326   | 319.25        | 319.25        |
| S24            | 326-334   | 327.25        | 327.25        |
| S25            | 334-342   | 335.25        | 335.25        |
| S26            | 342-350   | 343.25        | 343.25        |
| S27            | 350-358   | 351.25        | 351.25        |
| S28            | 358-366   | 359.25        | 359.25        |
| S29            | 366-374   | 367.25        | 367.25        |
| S30            | 374-382   | 375.25        | 375.25        |
| S31            | 382-390   | 383.25        | 383.25        |
| S32            | 390-398   | 391.25        | 391.25        |
| S33            | 398-406   | 399.25        | 399.25        |
| S34            | 406-414   | 407.25        | 407.25        |
| S35            | 414-422   | 415.25        | 415.25        |
| S36            | 422-430   | 423.25        | 423.25        |
| S37            | 430-438   | 431.25        | 431.25        |
| S38            | 438-446   | 439.25        | 439.25        |
| 21             | 470-478   | 471.25        | 471.25        |
| 22             | 478-486   | 479.25        | 479.25        |
| 23             | 486-494   | 487.25        | 487.25        |
| 24             | 494-502   | 495.25        | 495.25        |
| 25             | 502-510   | 503.25        | 503.25        |
| 26             | 510-518   | 511.25        | 511.25        |
| 27             | 518-526   | 519.25        | 519.25        |
| 28             | 526-534   | 527.25        | 527.25        |
| 29             | 534-542   | 535.25        | 535.25        |
| 30             | 542-550   | 543.25        | 543.25        |
| 31             | 550-558   | 551.25        | 551.25        |

| Channel Number | Bandwidth | Video Carrier | Audio Carrier |
|----------------|-----------|---------------|---------------|
| 32             | 558-566   | 559.25        | 559.25        |
| 33             | 566-574   | 567.25        | 567.25        |
| 34             | 574-582   | 575.25        | 575.25        |
| 35             | 582-590   | 583.25        | 583.25        |
| 36             | 590-598   | 591.25        | 591.25        |
| 37             | 598-606   | 599.25        | 599.25        |
| 38             | 606-614   | 607.25        | 607.25        |
| 39             | 614-622   | 615.25        | 615.25        |
| 40             | 622-630   | 623.25        | 623.25        |
| 41             | 630-638   | 631.25        | 631.25        |
| 42             | 638-646   | 639.25        | 639.25        |
| 43             | 646-654   | 647.25        | 647.25        |
| 44             | 654-662   | 655.25        | 655.25        |
| 45             | 662-670   | 663.25        | 663.25        |
| 46             | 670-678   | 671.25        | 671.25        |
| 47             | 678-686   | 679.25        | 679.25        |
| 48             | 686-694   | 687.25        | 687.25        |
| 49             | 694-702   | 695.25        | 695.25        |
| 50             | 702-710   | 703.25        | 703.25        |
| 51             | 710-718   | 711.25        | 711.25        |
| 52             | 718-726   | 719.25        | 719.25        |
| 53             | 726-734   | 727.25        | 727.25        |
| 54             | 734-742   | 735.25        | 735.25        |
| 55             | 742-750   | 743.25        | 743.25        |
| 56             | 750-758   | 751.25        | 751.25        |
| 57             | 758-766   | 759.25        | 759.25        |
| 58             | 766-774   | 767.25        | 767.25        |



| Channel Number | Bandwidth | Video Carrier | Audio Carrier |
|----------------|-----------|---------------|---------------|
| 59             | 774-782   | 775.25        | 775.25        |
| 60             | 782-790   | 783.25        | 783.25        |
| 61             | 790-798   | 791.25        | 791.25        |
| 62             | 798-806   | 799.25        | 799.25        |
| 63             | 806-814   | 807.25        | 807.25        |
| 64             | 814-822   | 815.25        | 815.25        |
| 65             | 822-830   | 823.25        | 823.25        |
| 66             | 830-838   | 831.25        | 831.25        |
| 67             | 838-846   | 839.25        | 839.25        |
| 68             | 846-854   | 847.25        | 847.25        |
| 69             | 854-862   | 855.25        | 855.25        |





## CHAPTER 115

# Flap List Troubleshooting

---

This document describes how to configure and use the Flap List Troubleshooting feature on the Cisco Cable Modem Termination System (CMTS) routers. The flap list is a patented tool for the Cisco CMTS routers to diagnose potential problems with a particular cable modem or with a particular cable interface. The flap list tracks "flapping" cable modems, which are cable modems that have intermittent connectivity problems. Excessive flapping could indicate a problem with a particular cable modem or with the upstream or downstream portion of the cable plant.

- [Finding Feature Information, on page 1855](#)
- [Hardware Compatibility Matrix for the Cisco cBR Series Routers, on page 1856](#)
- [Prerequisites for Flap List Troubleshooting, on page 1857](#)
- [Restrictions for Flap List Troubleshooting, on page 1857](#)
- [Information About Flap List Troubleshooting, on page 1857](#)
- [How to Configure Flap List Troubleshooting, on page 1860](#)
- [How to Monitor and Troubleshoot Using Flap Lists, on page 1865](#)
- [Configuration Examples for Flap List Troubleshooting, on page 1871](#)
- [Additional References, on page 1872](#)
- [Feature Information for Flap List Troubleshooting, on page 1873](#)

## Finding Feature Information

Your software release may not support all the features that are documented in this module. For the latest feature information and caveats, see the release notes for your platform and software release. The Feature Information Table at the end of this document provides information about the documented features and lists the releases in which each feature is supported.

Use Cisco Feature Navigator to find information about platform support and Cisco software image support. To access Cisco Feature Navigator, go to <http://tools.cisco.com/ITDIT/CFN/>. An account on <http://www.cisco.com/> is not required.

# Hardware Compatibility Matrix for the Cisco cBR Series Routers



**Note** The hardware components that are introduced in a given Cisco IOS-XE Release are supported in all subsequent releases unless otherwise specified.

*Table 365: Hardware Compatibility Matrix for the Cisco cBR Series Routers*

| Cisco CMTS Platform                    | Processor Engine                                                                                                                                                                                  | Interface Cards                                                                                                                                                                                                                                                                                                                                                                                                                                                                                                                                                                                                                                                                                                                                                                                 |
|----------------------------------------|---------------------------------------------------------------------------------------------------------------------------------------------------------------------------------------------------|-------------------------------------------------------------------------------------------------------------------------------------------------------------------------------------------------------------------------------------------------------------------------------------------------------------------------------------------------------------------------------------------------------------------------------------------------------------------------------------------------------------------------------------------------------------------------------------------------------------------------------------------------------------------------------------------------------------------------------------------------------------------------------------------------|
| Cisco cBR-8 Converged Broadband Router | <p><b>Cisco IOS-XE Release 16.5.1 and Later Releases</b></p> <p>Cisco cBR-8 Supervisor:</p> <ul style="list-style-type: none"> <li>• PID—CBR-SUP-250G</li> <li>• PID—CBR-CCAP-SUP-160G</li> </ul> | <p><b>Cisco IOS-XE Release 16.5.1 and Later Releases</b></p> <p>Cisco cBR-8 CCAP Line Cards:</p> <ul style="list-style-type: none"> <li>• PID—CBR-LC-8D30-16U30</li> <li>• PID—CBR-LC-8D31-16U30</li> <li>• PID—CBR-RF-PIC</li> <li>• PID—CBR-RF-PROT-PIC</li> <li>• PID—CBR-CCAP-LC-40G</li> <li>• PID—CBR-CCAP-LC-40G-R</li> <li>• PID—CBR-CCAP-LC-G2-R</li> <li>• PID—CBR-SUP-8X10G-PIC</li> <li>• PID—CBR-2X100G-PIC</li> </ul> <p>Digital PICs:</p> <ul style="list-style-type: none"> <li>• PID—CBR-DPIC-8X10G</li> <li>• PID—CBR-DPIC-2X100G</li> </ul> <p>Cisco cBR-8 Downstream PHY Module:</p> <ul style="list-style-type: none"> <li>• PID—CBR-D31-DS-MOD</li> </ul> <p>Cisco cBR-8 Upstream PHY Modules:</p> <ul style="list-style-type: none"> <li>• PID—CBR-D31-US-MOD</li> </ul> |



---

**Note** Do not use DPICs (8X10G and 2x100G) to forward IP traffic, as it may cause buffer exhaustion, leading to line card reload.

The only allowed traffic on a DPIC interface is DEPI, UEPI, and GCP traffic from the Cisco cBR-8 router to Remote PHY devices. Other traffic such as DHCP, SSH, and UTSC should flow via another router, since DPICs cannot be used for normal routing.

---

## Prerequisites for Flap List Troubleshooting

- To configure and access the flap list using SNMP commands, you must be using an SNMPv3 manager and have configured the Cisco CMTS router for SNMP operations.

## Restrictions for Flap List Troubleshooting

- The Flap List Troubleshooting feature can be used only with two-way cable modems. The flap-list does not support telco-return cable modems or set-top boxes.



---

**Note** Since the cable flap list was originally developed, polling mechanisms have been enhanced to have an increased rate of 1/sec when polls are missed. Cable modems can go offline faster than the frequency hop period, which can cause the frequency to stay fixed while cable modems go offline. To compensate for this, reduce the hop period to 10 seconds.

---

## Information About Flap List Troubleshooting

This section describes the following information about the Flap List Troubleshooting feature:

### Feature Overview

The Flap List Troubleshooting is a patented tool that is incorporated in the Cisco IOS software for the Cisco Cable Modem Termination System (CMTS) routers. The flap list tracks “flapping” cable modems, which are cable modems that have intermittent connectivity problems. A flapping cable modem can indicate either a problem with that particular cable modem, or it could indicate an RF noise problem with the upstream or downstream portion of the cable plant.

The flap-list feature supports any cable modem that conforms to the Data-over-Cable Service Interface Specifications (DOCSIS) because it does not use any special messaging to poll cable modems or to request any special information from them. Instead, this feature monitors the normal registration and station maintenance activity that is already performed over a DOCSIS cable network.

This allows the Cisco CMTS to collect the flap-list data without generating additional packet overhead and without impacting network throughput and performance. It also means that although the Flap List Troubleshooting feature is a proprietary feature for Cisco CMTS routers, it is compatible with all

DOCSIS-compliant cable modems. In addition, unlike other monitoring methods that use the Simple Network Management Protocol (SNMP), the flap list uses zero bandwidth.

## Information in the Flap List

The Flap List Troubleshooting feature tracks the following situations:

- **Reinsertions**—A reinsertion occurs when the cable modem re-registers more frequently than the user-specified insertion time. A pattern of reinsertions can indicate either potential problems in the downstream or that the cable modem is being improperly provisioned.
- **Hits and Misses**—A hit occurs when a cable modem successfully responds to the station maintenance messages (MAC-layer “keepalive” messages) that the Cisco CMTS sends out to conform to the DOCSIS standard. A miss occurs when the cable modem does not respond to the request within the user-specified timeout period. A pattern of misses can indicate a potential problem in either the downstream or upstream path, or that a problem can be occurring in the registration process.
- **Power Adjustments**—DOCSIS cable modems can adjust their upstream transmission power levels to adjust to unstable cable plant signal levels, up to a maximum allowable power level. Repeated power adjustments usually indicate a problem with an amplifier in the upstream return path.

The flap-list feature is automatically enabled, but to use the flap list effectively, the cable system administrator should also typically do the following:

- Set up a script to periodically poll the flap list, for example, every 15 minutes.
- Examine the resulting data and perform trend analysis to identify cable modems that are consistently in the flap list.
- Query the billing and administrative database for cable modem MAC address-to-street address translation and generate a report. The reports can be given to the customer service department or the cable plant’s operations and maintenance department. Using these reports, maintenance personnel can quickly discern how characteristic patterns of flapping cable modems, street addresses, and flap statistics indicate which amplifier or feeder lines are faulty. The reports also help to quickly discern whether problems exist in your downstream or upstream path and whether the problem is ingress noise or equipment related.

The flap list provides a quick way to quickly diagnose a number of possible problems. For example, if a subscriber reports a problem, but the flap list for the cable interface that is providing services to them shows little or no flap-list activity, the cable technician can assume that the Cisco CMTS and cable plant are communicating reliably. The problem, therefore, is probably in the subscriber’s computer equipment or in the local connection to the cable modem.

Similarly, a cable technician can use the pattern of reinsertions, hits and misses, and power adjustments to quickly troubleshoot the following types of problems:

- If a subscriber’s cable modem shows a lot of flap-list activity, it is having some kind of communication problem. Either the cable modem’s hardware is faulty, its installation is faulty, the coaxial cable being used is faulty, or some portion of the cable plant that services this cable modem is faulty.
- Focus on the top 10 percent of cable modems that are most active in the flap list, since these are the most likely to indicate consistent and pervasive plant or equipment problems that will continue to disrupt communication with the headend.
- Cable modems with more than 50 power adjustments per day have a suspect upstream path.
- Cable modems with approximately the same number of hits and misses and with a lot of insertions have a suspect downstream path (for example, low level into the cable modem).
- All cable modems incrementing the insertion at the same time indicates a problem with the provisioning servers.

- Cable modems with high cyclic redundancy check (CRC) errors have bad upstream paths or in-home wiring problems.
- Correlating cable modems on the same physical upstream port with similar flap-list statistics can quickly resolve outside plant problems to a particular node or geography.

In addition, the cable network administrators can use the flap list to collect quality control and upstream performance data. Typically, the network operations center (NOC) saves the flap list to a database on a local computer on a daily basis, providing the ability to generate reports that track upstream performance and installation quality control, as well as to provide trend reports on cable plant problems.



---

**Tip** The system supports automatic power adjustments. The show cable flap-list and show cable modem commands indicate when the headend cable router has detected an unstable return path for a particular modem and has compensated with a power adjustment. An asterisk (\*) appears in the power-adjustment field for a modem when a power adjustment has been made; an exclamation point (!) appears when the modem has reached its maximum power-transmit level and cannot increase its power level any further.

---

## Cisco Cable Manager and Cisco Broadband Troubleshooter

The Flap List Troubleshooting feature is supported by Cisco Cable Manager (CCM), Release 2.0 or later, which is a UNIX-based software suite that manages routers and DOCSIS-compliant cable modems, generates performance reports, troubleshoots connectivity problems, views the network graphically, and edits DOCSIS configuration files. You can access the CCM locally from the CCM server console or remotely from a UNIX workstation or a PC.

The Flap List Troubleshooting feature also works together with the Cisco Broadband Troubleshooter (CBT), which is a graphical-based application to manage and diagnose problems on the hybrid fiber-coaxial (HFC) network. Radio frequency (RF) technicians can quickly isolate plant and provisioning problems and characterize upstream and downstream trouble patterns, including analyzing flapping modems.

## Benefits

The Flap List Troubleshooting feature is a proactive way to manage and troubleshoot problems on an HFC network. Its use of passive monitoring is more scalable and efficient than techniques that send special messages to cable modems or that regularly poll the cable modems using Simple Network Management Protocol (SNMP) commands. Because it uses mechanisms that already exist in a DOCSIS network, it can be used with any DOCSIS-certified cable modem or set-top box.

The flap list provides a cable technician with both real-time and historical cable health statistics for quick, accurate problem isolation and network diagnosis. Using the flap list, a cable technician is able to do the following:

- Quickly learn how to characterize trouble patterns in the hybrid fiber-coaxial (HFC) network.
- Determine which amplifier or feeder line is faulty.
- Distinguish an upstream path problem from a downstream one.
- Isolate an ingress noise problem from a plant equipment problem.

# How to Configure Flap List Troubleshooting

This section describes how to configure the flap list operation on the Cisco CMTS. You can use either the command-line interface (CLI) commands or Simple Network Management Protocol (SNMP) commands to configure the flap list, to remove a cable modem from the list, or to clear the flap-list counters.

## Configuring Flap List Operation Using the CLI (optional)

To configure the operation of the flap list, use the following procedure, beginning in EXEC mode. This procedure is optional, unless you want to change the default values for the flap list.

### Procedure

|               | Command or Action                                                                                                                      | Purpose                                                                                                                                                                                                                                                                                                                                          |
|---------------|----------------------------------------------------------------------------------------------------------------------------------------|--------------------------------------------------------------------------------------------------------------------------------------------------------------------------------------------------------------------------------------------------------------------------------------------------------------------------------------------------|
| <b>Step 1</b> | <b>enable</b><br><b>Example:</b><br>Router> enable                                                                                     | Enables privileged EXEC mode. Enter your password if prompted.                                                                                                                                                                                                                                                                                   |
| <b>Step 2</b> | <b>configure terminal</b><br><b>Example:</b><br>Router# configure terminal                                                             | Enters global configuration mode.                                                                                                                                                                                                                                                                                                                |
| <b>Step 3</b> | <b>cable flap-list insertion-time <i>seconds</i></b><br><b>Example:</b><br>Router(config)# cable flap-list insertion-time 3600         | (Optional) Specifies the minimum insertion (registration) time interval in seconds. Any cable modem that makes a registration request more frequently than this period of time is placed in the flap list.                                                                                                                                       |
| <b>Step 4</b> | <b>cable flap-list power-adjust threshold <i>db</i></b><br><b>Example:</b><br>Router(config)# cable flap-list power-adjust threshold 5 | (Optional) Specifies the minimum power adjustment, in dB, that constitutes a flap-list event.<br><br><b>Note</b> A threshold of less than 2 dB can cause excessive flap-list event recording. If you need to change this parameter from its default, Cisco recommends setting it to 3 dB or higher.                                              |
| <b>Step 5</b> | <b>cable flap-list miss-threshold <i>misses</i></b><br><b>Example:</b><br>Router(config)# cable flap-list miss-threshold 10            | (Optional) Specifies the number of MAC-layer station maintenance (keepalive) messages that can be missed in succession before the CMTS places the cable modem in the flap list.<br><br><b>Note</b> A high miss rate indicates potential plant problems, such as intermittent upstream problems, fiber laser clipping, or common-path distortion. |



|               | Command or Action                                                                                                        | Purpose                                                                                                                                                                                                                               |
|---------------|--------------------------------------------------------------------------------------------------------------------------|---------------------------------------------------------------------------------------------------------------------------------------------------------------------------------------------------------------------------------------|
| <b>Step 6</b> | <b>cable flap-list aging</b> <i>minutes</i><br><b>Example:</b><br><pre>Router(config)# cable flap-list aging 20160</pre> | (Optional) Specifies how long, in minutes, the Cisco CMTS should keep information for cable modems in the flap list.                                                                                                                  |
| <b>Step 7</b> | <b>cable flap-list size</b> <i>number</i><br><b>Example:</b><br><pre>Router(config)# cable flap-list size 4000</pre>     | Specifies the maximum number of cable modems that can be kept in the flap list.<br><br><b>Tip</b> To avoid wasting processor memory, do not set this value beyond the actual number of cable modems being serviced by the Cisco CMTS. |
| <b>Step 8</b> | <b>exit</b><br><b>Example:</b><br><pre>Router(config)# exit</pre>                                                        | Exits global configuration mode.                                                                                                                                                                                                      |

## Clearing the Flap List and Counters Using the CLI (optional)

To clear one or more cable modems from the flap list, or to clear the flap list counters for one or more cable modems (while still keeping the modems in the flap list), use the following procedure, beginning in EXEC mode.

### Procedure

|               | Command or Action                                                                                                                                                                                                                                              | Purpose                                                                                                                   |
|---------------|----------------------------------------------------------------------------------------------------------------------------------------------------------------------------------------------------------------------------------------------------------------|---------------------------------------------------------------------------------------------------------------------------|
| <b>Step 1</b> | <b>enable</b><br><b>Example:</b><br><pre>Router&gt; enable</pre>                                                                                                                                                                                               | Enables privileged EXEC mode.<br><br><ul style="list-style-type: none"> <li>• Enter your password if prompted.</li> </ul> |
| <b>Step 2</b> | <b>clear cable flap-list</b> <i>mac-addr</i>   <b>all</b> } [ <b>save-counters</b> ]<br><b>Example:</b><br><pre>Router# clear cable flap-list 0102.0304.0506 save-counters</pre><br><b>Example:</b><br><pre>Router# clear cable flap-list 000C.0102.0304</pre> | Clears one or all cable modems from the flap list.                                                                        |
| <b>Step 3</b> | <b>clear cable modem</b> { <i>mac-addr</i>   <i>ip-addr</i>   [ <i>cable interface</i> ]} <b>all</b>   <b>ouistring</b>   <b>reject</b> } } <b>counters</b>                                                                                                    | Sets the flap-list counters to zero for one or more CMs.                                                                  |

| Command or Action                                                                                                                                                                                                                                                                                                                             | Purpose |
|-----------------------------------------------------------------------------------------------------------------------------------------------------------------------------------------------------------------------------------------------------------------------------------------------------------------------------------------------|---------|
| <p><b>Example:</b></p> <pre>Router# clear cable modem 172.12.23.45 counters</pre> <p><b>Example:</b></p> <pre>Router# clear cable modem oui Cisco counters</pre> <p><b>Example:</b></p> <pre>Router# clear cable modem reject counters</pre> <p><b>Example:</b></p> <pre>Router# clear cable modem c4/0 counters</pre> <p><b>Example:</b></p> |         |

## Enabling or Disabling Power Adjustment Using the CLI (optional)

The Cisco CMTS can automatically monitor a cable modem's power adjustments and determine whether a particular cable modem requires a change in the power adjustment method. To enable a cable interface to make automatic power adjustments, and to set the frequency threshold for when those adjustments are made, use the following procedure, beginning in EXEC mode.

### Procedure

|               | Command or Action                                                                                                                                          | Purpose                                                                                                                   |
|---------------|------------------------------------------------------------------------------------------------------------------------------------------------------------|---------------------------------------------------------------------------------------------------------------------------|
| <b>Step 1</b> | <p><b>enable</b></p> <p><b>Example:</b></p> <pre>Router&gt; enable</pre>                                                                                   | <p>Enables privileged EXEC mode.</p> <ul style="list-style-type: none"> <li>• Enter your password if prompted.</li> </ul> |
| <b>Step 2</b> | <p><b>configure terminal</b></p> <p><b>Example:</b></p> <pre>Router# configure terminal</pre>                                                              | <p>Enters global configuration mode.</p>                                                                                  |
| <b>Step 3</b> | <p><b>interface cable <i>x/y</i></b></p> <p><b>Example:</b></p> <pre>Router(config)# interface cable 4/0</pre>                                             | <p>Enters cable interface configuration mode for the specified cable interface.</p>                                       |
| <b>Step 4</b> | <p><b>cable upstream <i>n</i> power-adjust {continue <i>pwr-level</i>   noise <i>perc-pwr-adj</i>   threshold <i>value</i>}</b></p> <p><b>Example:</b></p> | <p>Enables automatic power adjustment on an upstream port for this cable interface.</p>                                   |

|        | Command or Action                                                                                                                                                   | Purpose                                                                                                                                                                                   |
|--------|---------------------------------------------------------------------------------------------------------------------------------------------------------------------|-------------------------------------------------------------------------------------------------------------------------------------------------------------------------------------------|
|        | <pre>Router(config-if)# cable upstream 0 power-adjust threshold 2</pre> <p><b>Example:</b></p> <pre>Router(config-if)# cable upstream 0 power-adjust noise 50</pre> | <p><b>Note</b> Repeat 4 for each upstream port on the cable interface.</p>                                                                                                                |
| Step 5 | <p><b>cable upstream n freq-adj averaging percent</b></p> <p><b>Example:</b></p> <pre>Router(config-if)# cable upstream 0 freq-adj averaging 50</pre>               | <p>Specifies the percentage of frequency adjustment packets needed to change the adjustment method from the regular power-adjustment method to the automatic power adjustment method.</p> |
| Step 6 | <p><b>exit</b></p> <p><b>Example:</b></p> <pre>Router(config-if)# exit</pre>                                                                                        | <p>Exits interface configuration mode.</p>                                                                                                                                                |
| Step 7 | <p><b>exit</b></p> <p><b>Example:</b></p> <pre>Router(config)# exit</pre>                                                                                           | <p>Exits global configuration mode.</p>                                                                                                                                                   |

**What to do next**



**Caution**

The default settings are adequate for system operation. Amplitude averaging is an automatic procedure. In general, Cisco does not recommend that you adjust values. Cisco does recommend, however, that you clean up your cable plant should you encounter flapping cable modems.



**Note**

In some instances, you might adjust certain values for the **cable upstream power-adjust** command: If CMs cannot complete ranging because they have reached maximum power levels, increase the **continue pwr-level** parameter beyond the default value of 2 dB. Values larger than 10 dB on “C” versions of cable interface line cards, or 5 dB on FPGA versions, are not recommended. If the flap list shows CMs with a large number of power adjustments, but the CMs are not detected as “noisy,” decrease the **noise perc-pwr-adj** value. If too many CMs are unnecessarily detected as “noisy,” increase the percentage.

## Configuring Flap List Operation Using SNMP (optional)

To configure the Flap List Troubleshooting feature on the Cisco CMTS using SNMP, set the appropriate `cssFlapObjects` attributes in the `CISCO-CABLE-SPECTRUM-MIB`. The table lists each of the configurable attributes:

Table 366: Flap-List Configuration Attributes

| Attribute                                | Type       | Range                    | Description                                                                                                                                                                                                 |
|------------------------------------------|------------|--------------------------|-------------------------------------------------------------------------------------------------------------------------------------------------------------------------------------------------------------|
| <code>cssFlapListMaxSize</code>          | Integer32  | 1 to 65536 <sup>13</sup> | The maximum number of modems that a flap list can support per line card. The default is 100. <sup>14</sup>                                                                                                  |
| <code>cssFlapListCurrentSize</code>      | Integer32  | 1 to 65536               | The current number of modems in the flap list. <sup>15</sup>                                                                                                                                                |
| <code>cssFlapAging</code>                | Integer32  | 1 to 86400               | The flap entry aging threshold in minutes. The default is 10080 minutes (180 hours or 7 days).                                                                                                              |
| <code>cssFlapInsertionTime</code>        | Integer32  | 60 to 86400              | The worst-case insertion time, in seconds. If a cable modem has not completed the registration stage within this interval, the cable modem is inserted into the flap list. The default value is 90 seconds. |
| <code>cssFlapPowerAdjustThreshold</code> | Integer32  | 1 to 10                  | When the power of the modem is adjusted beyond the power adjust threshold, the modem is inserted into the flap list.                                                                                        |
| <code>cssFlapMissThreshold</code>        | Unsigned32 | 1 to 12                  | When a cable modem does not acknowledge this number of consecutive MAC-layer station maintenance (keepalive) messages, the cable modem is placed in the flap list.                                          |

<sup>13</sup> The allowable range when using SNMP for these parameters is 1 to 65536 (a 32-bit value), but the valid operational range is 1 to 8191.

<sup>14</sup> This value is the same as set by the `cable flap-list size` command and is applied only to the command output. The flap list entries displayed via SNMP are not affected by this.

<sup>15</sup> The number of SNMP entries is the same as this value. The number of the CLI entries depends on the value set by `cssFlapListMaxSize`.



**Note** `cssFlapListMaxSize` controls the display of the flap list per downstream cable interface. As long as the number of flap list entries per line card does not exceed 8191, these entries will be stored in the system, and will not be displayed via CLI.

`cssFlapListCurrentSize` reflects the number of flap list entries of all the line cards that in the system, regardless of their visibility to the CLI.

## Clearing the Flap List and Counters Using SNMP (optional)

To remove a cable modem from the flap list or to clear one or all of the flap-list counters, set the appropriate `cssFlapObjects` attributes in the `CISCO-CABLE-SPECTRUM-MIB`. The table lists the attributes that clear the SNMP counters.

Table 367: Attributes to Clear the Flap List

| Attribute       | Type    | Description                                                                                                                                                                                                       |
|-----------------|---------|-------------------------------------------------------------------------------------------------------------------------------------------------------------------------------------------------------------------|
| ccsFlapResetAll | Boolean | Setting this object to True (1) resets all flap-list counters to zero.                                                                                                                                            |
| ccsFlapClearAll | Boolean | Setting this object to True (1) removes all cable modems from the flap list, and destroys all entries in the ccsFlapTable. If a modem keeps flapping, the modem is added again into the flap list as a new entry. |



**Note** The ccsFlapLastClearTime attribute contains the date and time that the entries in the ccsFlapTable table were last cleared.

# How to Monitor and Troubleshoot Using Flap Lists

## Displaying the Flap List Using the show cable flap-list Command

To display the current contents of the flap list, use the show cable flap-list command in privileged EXEC mode. This command has the following syntax:

- **show cable flap-list**—Displays the complete flap list.
- **show cable flap-list sort-interface**—Displays the complete flap list sorted by cable interface.
- **show cable flap-list cable interface upstream port**—Displays the flap list for a specific cable interface, or for a specific upstream port on that cable interface.

To change the way the output is sorted, add one of the following optional keywords:

- **sort-flap**—Sorts the output by the number of times that the cable modem has flapped.
- **sort-time**—Sorts the output by the most recent time that the cable modem flapped.

The following example shows typical output of the **show cable flap-list** command.

```
Router# show cable flap-list
Mac Addr      CableIF Ins  Hit  Miss  CRC  P-Adj  Flap  Time
0010.9500.461f C1/0 U1 56 18857 887 0 1 116 Jun 1 14:09:12
0010.9500.446e C1/0 U1 38 18686 2935 0 1 80 Jun 2 19:03:57
0010.9500.38ec C1/0 U2 63 18932 1040 0 8 138 Jun 2 23:50:53
0010.9500.4474 C1/0 U2 65 18913 1053 0 3 137 Jun 2 09:30:09
0010.9500.4672 C1/0 U2 56 18990 2327 0 6 124 Jun 2 10:44:14
0010.9500.38f0 C1/0 U2 50 18964 2083 0 5 111 Jun 2 20:46:56
0010.9500.e8cb C1/0 U2 0 6537 183 0 1 5 Jun 2 22:35:48
0010.9500.38f6 C1/0 U3 50 19016 2511 0 2 104 Jun 2 07:46:31
0010.9500.4671 C1/0 U3 43 18755 3212 1 1 89 Jun 1 19:36:20
0010.9500.38eb C1/0 U0 57 36133 1608 0 6 126 Jun 2 20:04:58
0010.9500.3ce2 C1/0 U0 44 35315 1907 0 4 99 Jun 2 16:42:47
0010.9500.e8d0 C1/0 U2 0 13213 246 0 1 5 Jun 3 04:15:30
0010.9500.4674 C1/0 U2 56 36037 2379 0 4 121 Jun 3 00:34:12
0010.9500.4677 C1/0 U2 40 35781 2381 0 4 91 Jun 2 12:14:38
0010.9500.4614 C1/0 U2 40 21810 2362 0 502 586 Jun 2 21:43:02
0010.9500.3be9 C1/0 U2 63 22862 969 0 0 128 Jun 1 14:09:03
0010.9500.4609 C1/0 U2 55 22723 2127 0 0 112 Jun 1 14:08:02
0010.9500.3cb8 C1/0 U2 49 22607 1378 0 0 102 Jun 1 14:08:58
```

```

0010.9500.460d C1/0 U3 46 22477 2967 0 2 96 Jun 2 17:03:48
0010.9500.3cba C1/0 U3 39 22343 3058 0 0 81 Jun 1 14:13:16
0010.9500.3cb4 C1/0 U3 38 22238 2936 0 0 79 Jun 1 14:09:26
0010.9500.4612 C1/0 U3 38 22306 2928 0 0 79 Jun 1 14:09:29
Router#
    
```

## Displaying the Flap List Using the show cable modem flap Command

To display the contents of the flap list for a specific cable modem, use the **show cable modem flap** command in privileged EXEC mode. This command has the following syntax:

- **show cable modem** [*ip-address* | *mac-address*] **flap**—Displays the flap list for a specific cable modem, as identified by its IP address or MAC address.
- **show cable modem cableinterface** [*upstream port*] **flap**—Displays the flap list for all cable modems on a specific cable interface.



**Note** The **show cable modem flap** command displays information similar to that shown by the **show cable flap-list** command, except it displays this information on a per-modem basis.

The following example shows sample output for the **show cable modem flap** command for a particular cable modem:

```

Router# show cable modem 0010.7bb3.fcd1 flap
MAC Address    I/F          Ins   Hit   Miss  CRC   P-Adj  Flap  Time
0010.7bb3.fcd1 C5/0/U5     0    36278 92    0    369    372  Jun 1 13:05:23 (18000msec)
    
```

The following example shows sample output for the **show cable modem flap** command for all cable modems on a specific cable interface:

```

Router# show cable modem cable 6/0/0 flap
MAC Address    I/F          Ins   Hit   Miss  CRC   P-Adj  Flap  Time
0025.2e34.4386 C6/0/0/U0    0    46778 3980  0    0      0    (14212 msec)
0025.2e2f.d4b6 C6/0/0/U0    0    48002 1899  0    0      0    (18000 msec)
0025.2e2f.d4de C6/0/0/U0    0    48098 1889  0    0      0    (19552 msec)
0023.bee1.e96b C6/0/0/U0    0    46658 4351  0    0      0    (22432 msec)
0025.2e2f.d4d8 C6/0/0/U0    0    21979 781   0    0      0    ( -- )
0025.2e2f.d48c C6/0/0/U0    0    48048 1835  0    0      0    ( -- )
0025.2e2f.d490 C6/0/0/U0    0    48029 1819  0    0      0    ( -- )
    
```

## Displaying the Flap List Using SNMP

To display the contents of the flap list using SNMP, query the `ccsFlapTable` table in the `CISCO-CABLE-SPECTRUM-MIB`. This table contains an entry for each cable modem. The table briefly describes each attribute in this table.

Table 368: ccsFlapTable Attributes

| Attribute                 | Type           | Description                                                                                                                                                                                                                                                                                                                                                                                                                                                                                                                                                     |
|---------------------------|----------------|-----------------------------------------------------------------------------------------------------------------------------------------------------------------------------------------------------------------------------------------------------------------------------------------------------------------------------------------------------------------------------------------------------------------------------------------------------------------------------------------------------------------------------------------------------------------|
| ccsFlapMacAddr            | MacAddress     | MAC address of the cable modem's cable interface. Identifies a flap-list entry for a flapping cable modem.                                                                                                                                                                                                                                                                                                                                                                                                                                                      |
| ccsFlapUpstreamIfIndex    | InterfaceIndex | Upstream being used by the flapping cable modem.                                                                                                                                                                                                                                                                                                                                                                                                                                                                                                                |
| ccsFlapDownstreamIfIndex  | InterfaceIndex | Downstream being used by the flapping cable modem.                                                                                                                                                                                                                                                                                                                                                                                                                                                                                                              |
| ccsFlapLastFlapTime       | DateAndTime    | Time stamp for the last time the cable modem flapped.                                                                                                                                                                                                                                                                                                                                                                                                                                                                                                           |
| ccsFlapCreateTime         | DateAndTime    | Time stamp that this entry was added to the table.                                                                                                                                                                                                                                                                                                                                                                                                                                                                                                              |
| ccsFlapRowStatus          | RowStatus      | Control attribute for the status of this entry.                                                                                                                                                                                                                                                                                                                                                                                                                                                                                                                 |
| ccsFlapInsertionFailNum   | Unsigned32     | Number of times the CM comes up and inserts itself into the network. This counter is increased when the time between initial link establishment and a reestablishment was less than the threshold parameter configured using the <b>cable flap-list insertion-time</b> command or ccsFlapInsertionTime attribute.<br><br>When the cable modem cannot finish registration within the insertion time (ccsFlapInsertionTime), it resends the Initial Maintenance packet. When the CMTS receives the packet sooner than expected, the CMTS increments this counter. |
| ccsFlapHitNum             | Unsigned32     | Number of times the CM responds to MAC-layer station maintenance (keepalive) messages. (The minimum hit rate is once per 30 seconds.)                                                                                                                                                                                                                                                                                                                                                                                                                           |
| ccsFlapMissNum            | Unsigned32     | Number of times the CM misses and does not respond to a MAC-layer station maintenance (keepalive) message. An 8 percent miss rate is normal for the Cisco cable interface line cards. If the CMTS misses a ranging request within 25 msec, then the miss number is incremented.                                                                                                                                                                                                                                                                                 |
| ccsFlapCrcErrorNum        | Unsigned32     | Number of times the CMTS upstream receiver flagged a packet with a CRC error. A high value indicates that the cable upstream may have a high noise level. The modem may not be flapping yet, but this could become a possible problem.                                                                                                                                                                                                                                                                                                                          |
| ccsFlapPowerAdjustmentNum | Unsigned32     | Number of times the cable modem upstream transmit power is adjusted during station maintenance. When the adjustment is greater than the power-adjustment threshold, the number is incremented.                                                                                                                                                                                                                                                                                                                                                                  |
| ccsFlapTotalNum           | Unsigned32     | Number of times a modem has flapped, which is the sum of the following: <ul style="list-style-type: none"> <li>• When ccsFlapInsertionFailNum is increased</li> <li>• When the CMTS receives a miss followed by a hit</li> <li>• When ccsFlapPowerAdjustmentNum is increased</li> </ul>                                                                                                                                                                                                                                                                         |
| ccsFlapResetNow           | Boolean        | Setting this object to True (1) resets all flap-list counters to zero.                                                                                                                                                                                                                                                                                                                                                                                                                                                                                          |
| ccsFlapLastResetTime      | DateAndTime    | Time stamp for when all the counters for this particular entry were reset to zero.                                                                                                                                                                                                                                                                                                                                                                                                                                                                              |

## Displaying Flap-List Information for Specific Cable Modems

To use SNMP requests to display flap-list information for a specific cable modem, use the cable modem's MAC address as the index to retrieve entries from the `ccsFlapTable`. Use the following procedure to retrieve flap-list entries for a particular cable modem.

- 
- Step 1** Convert the cable modem's MAC address into a dotted decimal string. For example, the MAC address 000C.64ff.eb95 would become 0.12.100.255.235.149.
- Step 2** Use the dotted decimal version of the MAC address as the instance for requesting information from the `ccsFlapTable`. For example, to retrieve the `ccsFlapHits`, `ccsFlapMisses`, and `ccsFlapPowerAdjustments` values for this cable modem, you would make an SNMP request for the following objects:
- `ccsFlapHits.0.12.100.255.235.149`
  - `ccsFlapMisses.0.12.100.255.235.149`
  - `ccsFlapPowerAdjustments.0.12.100.255.235.149`
- 

### Example

Assume that you want to retrieve the same flap-list information as the `show cable flap-list` command for a cable modem with the MAC address of 000C.64ff.eb95:

```
Router# show cable flap-list
MAC Address      Upstream      Ins   Hit   Miss  CRC   P-Adj  Flap  Time
000C.64ff.eb95  Cable3/0/U4   3314  55605 50460 0      *42175 47533 Jan 27 02:49:10
Router#
```

Use an SNMP tool to retrieve the `ccsFlapTable` and filter it by the decimal MAC address. For example, using the standard Unix `getone` command, you would give the following command:

```
csh% getmany -v2c 192.168.100.121 public ccsFlapTable | grep 0.12.100.255.235.149

ccsFlapUpstreamIfIndex.0.12.100.255.235.149 = 15
ccsFlapDownstreamIfIndex.0.12.100.255.235.149 = 17
ccsFlapInsertionFails.0.12.100.255.235.149 = 3315
ccsFlapHits.0.12.100.255.235.149 = 55608
ccsFlapMisses.0.12.100.255.235.149 = 50460
ccsFlapCrcErrors.0.12.100.255.235.149 = 0
ccsFlapPowerAdjustments.0.12.100.255.235.149 = 42175
ccsFlapTotal.0.12.100.255.235.149 = 47534
ccsFlapLastFlapTime.0.12.100.255.235.149 = 07 d4 01 1b 02 33 1a 00
ccsFlapCreateTime.0.12.100.255.235.149 = 07 d4 01 16 03 23 22 00
ccsFlapRowStatus.0.12.100.255.235.149 = active(1)
ccsFlapInsertionFailNum.0.12.100.255.235.149 = 3315
ccsFlapHitNum.0.12.100.255.235.149 = 55608
ccsFlapMissNum.0.12.100.255.235.149 = 50460
ccsFlapCrcErrorNum.0.12.100.255.235.149 = 0
ccsFlapPowerAdjustmentNum.0.12.100.255.235.149 = 42175
ccsFlapTotalNum.0.12.100.255.235.149 = 47534
ccsFlapResetNow.0.12.100.255.235.149 = false(2)
ccsFlapLastResetTime.0.12.100.255.235.149 = 07 d4 01 16 03 20 18 00
csh%
```



To request just one particular value, use the decimal MAC address as the instance for that object:

```
csH% getone -v2c 172.22.85.7 public ccsFlapMisses.0.12.100.255.235.149
ccsFlapMisses.0.12.100.255.235.149 = 50736
csH %
```

## Troubleshooting Suggestions

This section provides tips on how to interpret the flap-list counters, as well as how to determine the optimum power level for a flapping cable modem.

### Troubleshooting Tips

This section includes suggestions on how to interpret different network conditions based on the flap-list statistics:

- Condition 1: Low miss or hit ratio, low insertion, low P-Adj, low flap counter, and old time stamp. Analysis: This exhibits an optimal network situation.
- Condition 2: High ratio of misses over hits (> 10 percent). Analysis: Hit and miss analysis should be done after the Ins count stops incrementing. In general, if the hit and miss counts are about the same order of magnitude, the upstream can be experiencing noise. If the miss count is greater, then the modem is probably dropping out frequently and not completing registration. The upstream or downstream might not be stable enough for reliable link establishment. Very low hits and miss counters and high insertion counters indicate provisioning problems.
- Condition 3: Relatively high power-adjustment counter. Analysis: Indicates that the power-adjustment threshold is probably set at default value of 2 dB. The modem transmitter step size is 1.5 dB, but the headend can command 0.25 dB step sizes. Tuning your power threshold to 6 dB is recommended to decrease irrelevant entries in the flap list. The power-adjustment threshold can be set using cable flap power threshold <0-10 dB> in the Cisco IOS global configuration mode. A properly operating HFC network with short amplifier cascades can use a 2 to 3 dB threshold.
- Condition 4: High P-Adj and CRC errors. Analysis: This condition can indicate that the fiber node is clipping the upstream return laser. Evaluate the modems with the highest CRC count first. If the modems are not going offline (Ins = 0), this is not noticed by subscribers. However, they could receive slower service due to dropped IP packets in the upstream. This condition also results in input errors on the Cisco CMTS router cable interface.
- Condition 5: High insertion rate. Analysis: If link reestablishment happens too frequently, the modem is usually having a registration problem. This is indicated by a high Ins counter, which tracks the Flap counter.

### Performing Amplitude Averaging

The CMTS uses an averaging algorithm to determine the optimum power level for a cable modem with low carrier-to-noise ratio that is making excessive power adjustments—known as flapping. To avoid dropping flapping cable modems, the CMTS averages a configurable number of RNG-REQ messages before it makes power adjustments. By compensating for a potentially unstable return path, the CMTS maintains connectivity with affected cable modems. You can interpret these power adjustments, however, as indicating unstable return path connections.

The **show cable flap-list** and **show cable modem** commands are expanded to indicate to which paths the CMTS is making power adjustments and which modems have reached maximum transmit power settings. These conditions indicate unstable paths that should be serviced.

The following example shows the output of the **show cable flap-list** command:

```
Router# show cable flap-list
MAC Address      Upstream      Ins   Hit   Miss  CRC   P-Adj  Flap  Time
0010.7bb3.fd19  Cable1/0/U1  0     2792 281   0     *45   58   Jul 27 16:54:50
0010.7bb3.fcfc  Cable1/0/U1  0     19    4     0     !43   43   Jul 27 16:55:01
0010.7bb3.fcdd  Cable1/0/U1  0     19    4     0     *3    3    Jul 27 16:55:01
```

The asterisk (\*) indicates that the CMTS is using the power-adjustment method on this modem. An exclamation point (!) indicates that the modem has reached maximum transmit power.

Output of the **show cable modem** command appears below:

```
Router# show cable modem
Interface      Prim Online      Timing Rec      QoS CPE IP address      MAC address
  Sid  State      Offset Power
Cable1/0/U0 1  online      2257 0.00 3 0 10.30.128.142 0090.8330.0217
Cable1/0/U0 2  online      2262 *-0.50 3 0 10.30.128.145 0090.8330.020f
Cable1/0/U0 3  online      2260 0.25 3 0 10.30.128.146 0090.8330.0211
Cable1/0/U0 4  online      2256 *0.75 3 0 10.30.128.143 0090.8330.0216
Cable1/0/U0 5  online      2265 *0.50 3 0 10.30.128.140 0090.8330.0214
Cable1/0/U0 6  online      2256 0.00 3 0 10.30.128.141 0090.8330.0215
Cable1/0/U0 7  online      4138 !-1.00 3 1 10.30.128.182 0050.7366.124d
Cable1/0/U0 8  online      4142 !-3.25 3 1 10.30.128.164 0050.7366.1245
Cable1/0/U0 9  online      4141 !-3.00 3 1 10.30.128.185 0050.7366.17e3
Cable1/0/U0 10 online      4142 !-2.75 3 0 10.30.128.181 0050.7366.17ab
Cable1/0/U0 11 online      4142 !-3.25 3 1 10.30.128.169 0050.7366.17ef
```

Similar to the **show cable flap-list** command display, the \* symbol in the **show cable modem** command output indicates that the CMTS is using the power-adjustment method on this CM. The ! symbol indicates that the CM has reached maximum transmit power.

## Using Other Related Commands

The following related Cisco IOS commands can be used to do maintenance on or display information about a cable modem.

- The following clears the counters for a cable modem (or all cable modems) in the station maintenance list:

```
clear cable modem {mac-addr | ip-addr | all} counters
```

- The following displays the QoS, modem status, In and Out octets, IP and MAC addresses per SID:

```
show int cable slot/port sid
```

- The following drops the modem's RF link by removing a modem from the keepalive polling list. This forces the modem to reset. Note the warning below.

```
clear cable-modem {mac-addr | ip-addr | all} reset
```



**Tip** The **clear cable-modem all reset** command causes all modems to go offline and disrupt service for your users. It is best used in a test or nonproduction environment.

- The following uses a MAC-layer ping to determine if the cable modem is online. It uses smaller data units on the wire than a standard IP ping, resulting in lower overhead. This command works even if the IP layer in the modem is down or has not completed registration:

```
ping DOCSIS cable-modem mac-addr | IP address
```

- The following displays the timing offset, receive power, and QoS values by cable interface, SID, and MAC address:

```
show cable modem [ip-address | MAC-address]
```

- The following displays the current allocation table and frequency assignments:

```
show cable spectrum-group [spectrum group number]
```

- The following displays maximum, average, and minimum percent of online time and offline time for a given SID on a given cable router interface:

```
show int slot/port sid connectivity
```

- The following command displays input and output rates, input errors, CRC, frames, overruns, underruns, collisions, interface resets. High input errors in the CMTS retrieved from this query suggest noisy upstream. In older versions of the chassis, loose midplane and line card screws caused a similar problem:

```
show interface slot/downstream-port
```

- The following command displays upstream packet discards, errors, error-free packets, correctable and uncorrectable errors, noise, and micro-reflection statistics.

```
show interface slot/downstream-port upstream
```

## Configuration Examples for Flap List Troubleshooting

The following excerpt from a configuration file shows a typical flap-list configuration:

```
!  
cable flap-list insertion-time 120  
cable flap-list power-adjust threshold 3  
cable flap-list miss-threshold 4  
cable flap-list aging 8
```

```
cable flap-list size 8191
...
```

## Additional References

For additional information related to the Flap List Troubleshooting feature, refer to the following references:

### Related Documents

| Related Topic                  | Document Title                                                                                                                                                                  |
|--------------------------------|---------------------------------------------------------------------------------------------------------------------------------------------------------------------------------|
| CMTS Command Reference         | <a href="#">Cisco CMTS Cable Command Reference</a>                                                                                                                              |
| Cisco Broadband Troubleshooter | <a href="http://www.cisco.com/c/en/us/support/cloud-systems-management/broadband-troubles">http://www.cisco.com/c/en/us/support/cloud-systems-management/broadband-troubles</a> |

### Standards

| Standards <sup>16</sup>                                          | Title                                                                                      |
|------------------------------------------------------------------|--------------------------------------------------------------------------------------------|
| <a href="#">ANSI/SCTE 22-1 2012</a> (formerly SP-RFI-C01-011119) | Data-Over-Cable Service Interface Specification DOCSIS 1.0 Radio Frequency Interface (RFI) |
| <a href="#">SP-RFIV1.1-I08-020301</a>                            | Data-over-Cable Service Interface Specifications Radio Frequency Interface Specification   |
| <a href="#">SP-BPI+-I08-020301</a>                               | DOCSIS Baseline Privacy Interface Plus Specification                                       |

<sup>16</sup> Not all supported standards are listed.

### MIBs

| MIBs <sup>17</sup>       | MIBs Link                                                                                                                                                                                                                                                             |
|--------------------------|-----------------------------------------------------------------------------------------------------------------------------------------------------------------------------------------------------------------------------------------------------------------------|
| CISCO-CABLE-SPECTRUM-MIB | To locate and download MIBs for selected platforms, Cisco software releases, and feature sets, use Cisco MIB Locator found at the following URL:<br><br><a href="http://tools.cisco.com/ITDIT/MIBS/servlet/index">http://tools.cisco.com/ITDIT/MIBS/servlet/index</a> |

<sup>17</sup> Not all supported MIBs are listed.

### RFCs

| Description                                            | Link                                                                                                                                                                                                                                     |
|--------------------------------------------------------|------------------------------------------------------------------------------------------------------------------------------------------------------------------------------------------------------------------------------------------|
| No new or modified RFCs are supported by this feature. | To locate and download Request for Comments (RFCs) and Internet Drafts, see the Internet Engineering Task Force (IETF) web site at the following URL:<br><br><a href="http://www.ietf.org/index.html">http://www.ietf.org/index.html</a> |

**Technical Assistance**

| Description                                                                                                                                                                                                                                                                                                                                                                           | Link                                                                                                              |
|---------------------------------------------------------------------------------------------------------------------------------------------------------------------------------------------------------------------------------------------------------------------------------------------------------------------------------------------------------------------------------------|-------------------------------------------------------------------------------------------------------------------|
| The Cisco Support and Documentation website provides online resources to download documentation, software, and tools. Use these resources to install and configure the software and to troubleshoot and resolve technical issues with Cisco products and technologies. Access to most tools on the Cisco Support and Documentation website requires a Cisco.com user ID and password. | <a href="http://www.cisco.com/cisco/web/support/index.html">http://www.cisco.com/cisco/web/support/index.html</a> |

## Feature Information for Flap List Troubleshooting

Use Cisco Feature Navigator to find information about the platform support and software image support. Cisco Feature Navigator enables you to determine which software images support a specific software release, feature set, or platform. To access Cisco Feature Navigator, go to the <https://cfng.cisco.com/> link. An account on the Cisco.com page is not required.



**Note** The following table lists the software release in which a given feature is introduced. Unless noted otherwise, subsequent releases of that software release train also support that feature.

*Table 369: Feature Information for Flap List Troubleshooting*

| Feature Name              | Releases                    | Feature Information                                                                                               |
|---------------------------|-----------------------------|-------------------------------------------------------------------------------------------------------------------|
| Flap List Troubleshooting | Cisco IOS XE Everest 16.6.1 | This feature was integrated into Cisco IOS XE Everest 16.6.1 on the Cisco cBR Series Converged Broadband Routers. |





## CHAPTER 116

# Maximum CPE and Host Parameters

---

This document describes how to use different methods to control subscriber access that are allowed by the Data-over-Cable Service Interface Specifications (DOCSIS) for use on cable networks.

- [Finding Feature Information, on page 1875](#)
- [Hardware Compatibility Matrix for the Cisco cBR Series Routers, on page 1875](#)
- [Information About the MAX CPE and Host Parameters, on page 1877](#)
- [How to Configure the MAX CPE and Host Parameters, on page 1880](#)
- [Configuration Examples, on page 1882](#)
- [Additional References, on page 1883](#)
- [Feature Information for Maximum CPE and Host Parameters, on page 1884](#)

## Finding Feature Information

Your software release may not support all the features that are documented in this module. For the latest feature information and caveats, see the release notes for your platform and software release. The Feature Information Table at the end of this document provides information about the documented features and lists the releases in which each feature is supported.

Use Cisco Feature Navigator to find information about platform support and Cisco software image support. To access Cisco Feature Navigator, go to <http://tools.cisco.com/ITDIT/CFN/>. An account on <http://www.cisco.com/> is not required.

## Hardware Compatibility Matrix for the Cisco cBR Series Routers



---

**Note** The hardware components that are introduced in a given Cisco IOS-XE Release are supported in all subsequent releases unless otherwise specified.

---

Table 370: Hardware Compatibility Matrix for the Cisco cBR Series Routers

| Cisco CMTS Platform                    | Processor Engine                                                                                                                                                                                  | Interface Cards                                                                                                                                                                                                                                                                                                                                                                                                                                                                                                                                                                                                                                                                                                                                                                                 |
|----------------------------------------|---------------------------------------------------------------------------------------------------------------------------------------------------------------------------------------------------|-------------------------------------------------------------------------------------------------------------------------------------------------------------------------------------------------------------------------------------------------------------------------------------------------------------------------------------------------------------------------------------------------------------------------------------------------------------------------------------------------------------------------------------------------------------------------------------------------------------------------------------------------------------------------------------------------------------------------------------------------------------------------------------------------|
| Cisco cBR-8 Converged Broadband Router | <p><b>Cisco IOS-XE Release 16.5.1 and Later Releases</b></p> <p>Cisco cBR-8 Supervisor:</p> <ul style="list-style-type: none"> <li>• PID—CBR-SUP-250G</li> <li>• PID—CBR-CCAP-SUP-160G</li> </ul> | <p><b>Cisco IOS-XE Release 16.5.1 and Later Releases</b></p> <p>Cisco cBR-8 CCAP Line Cards:</p> <ul style="list-style-type: none"> <li>• PID—CBR-LC-8D30-16U30</li> <li>• PID—CBR-LC-8D31-16U30</li> <li>• PID—CBR-RF-PIC</li> <li>• PID—CBR-RF-PROT-PIC</li> <li>• PID—CBR-CCAP-LC-40G</li> <li>• PID—CBR-CCAP-LC-40G-R</li> <li>• PID—CBR-CCAP-LC-G2-R</li> <li>• PID—CBR-SUP-8X10G-PIC</li> <li>• PID—CBR-2X100G-PIC</li> </ul> <p>Digital PICs:</p> <ul style="list-style-type: none"> <li>• PID—CBR-DPIC-8X10G</li> <li>• PID—CBR-DPIC-2X100G</li> </ul> <p>Cisco cBR-8 Downstream PHY Module:</p> <ul style="list-style-type: none"> <li>• PID—CBR-D31-DS-MOD</li> </ul> <p>Cisco cBR-8 Upstream PHY Modules:</p> <ul style="list-style-type: none"> <li>• PID—CBR-D31-US-MOD</li> </ul> |



**Note** Do not use DPICs (8X10G and 2x100G) to forward IP traffic, as it may cause buffer exhaustion, leading to line card reload.

The only allowed traffic on a DPIC interface is DEPI, UEPI, and GCP traffic from the Cisco cBR-8 router to Remote PHY devices. Other traffic such as DHCP, SSH, and UTSC should flow via another router, since DPICs cannot be used for normal routing.



## Information About the MAX CPE and Host Parameters

The DOCSIS specification includes a number of provisions to allow service providers to control the number of subscribers who can access the network through any particular cable modem.

The following are the parameters that controls the number of CPE that can access the network:



---

**Note** In addition, the DOCSIS configuration file contains a Network Access parameter that specifies whether the CPE devices behind the cable modem can access the cable network. If the Network Access parameter is set to Disabled, no CPE devices behind a cable modem are able to access the network.

---



---

**Tip** Also, the Cisco CMTS lists offline cable modems in its internal database for 24 hours. The CMTS does not reset the CPE counts for these offline cable modems until the 24 hour period expires and the cable modems come back online. If the cable modems come back online before the 24 hour period expires, the CMTS continues to use the existing CPE counts.

---

All of these methods are similar in purpose, but they are configured differently and have a different impact on cable modems and their CPE devices.

The cable modem enforces the MAX CPE value, the CMTS enforces the MAX Host, MAX CPE IP, and MAX CPE IPv6 values.



---

**Note** The MAX CPE parameter provides Layer 2 control of CPE devices. The MAX CPE IP and MAX CPE IPv6 parameters provide Layer 3 control of CPE devices. The two methods are complimentary but not otherwise related.

---

## MAX CPE

The MAX CPE is a required parameter and used to control the number of CPE devices that can access the network during the current session. In DOCSIS 1.0 cable networks, the MAX CPE parameter is the primary means of controlling the number of CPE devices that can connect to the cable network using any particular cable modem. This parameter is configured in the DOCSIS configuration file (TLV 18). If this parameter is not specified in the DOCSIS configuration file, it defaults to a value of 1.



---

**Note** In DOCSIS 1.1 cable networks, the CMTS ignores the MAX CPE parameter that is specified in the DOCSIS configuration file, and uses the MAX Host parameter instead.

---

Each time a new CPE device attempts to connect to the cable network, the cable modem logs the hardware (MAC) address. If the cable modem has not reached the MAX CPE number of MAC addresses, the new CPE device is allowed to access the network. If the cable modem has reached the MAX CPE limit, it drops the traffic from any additional CPE devices.

By default, the cable modem learns new MAC addresses on a first-come, first-served basis. You can also preconfigure the allowable MAC addresses for CPE devices by entering those MAC addresses in the DOCSIS configuration file (TLV 14). These cable modem gives these preconfigured MAC addresses preference in connecting to the network.

The DOCSIS specification does not allow cable modems to age out MAC addresses, so a MAC address stays in the log table of the cable modem until the cable modem is reset. You should therefore think of this parameter as specifying the maximum number of CPE devices that can connect during any particular session, instead of the maximum number of CPE devices that can simultaneously connect to the cable network.

For example, if you set MAX CPE to 2, a customer could use their cable modem to connect a maximum of two CPE devices (two MAC addresses) to the cable network. A customer could choose to connect two PCs simultaneously to their cable modem and use both to access the network.

However, if the customer then disconnected these PCs and connected two new PCs, the cable modem would not allow the new PCs to come online, because they would be the third and fourth MAC addresses that are connected to the cable modem. The customer would have to reset the cable modem before being able to use the new PCs.



---

**Note** The MAX CPE value, if present, must be a positive integer in DOCSIS 1.0 configuration files. This parameter can be zero in DOCSIS 1.1 configuration files, but if so, the cable modem uses a MAX CPE value of 1. If the MAX CPE parameter is not present in either type of DOCSIS configuration file, it defaults to 1.

---

## MAX Host

The MAX Host parameter is an optional parameter and is configured on the Cisco CMTS and specifies the maximum number of CPE devices (MAC addresses) that the CMTS will allow to have network access. You can control this parameter for individual cable modems, for all cable modems on a particular cable interface, or for all cable modems on the Cisco CMTS, depending on the CLI command being used:

- **cable modem max-cpe**—Configures MAX Host for all cable modems on the Cisco CMTS. You can use the **unlimited** keyword to specify that the Cisco CMTS should not enforce a MAX Host limit for cable modems.

When this is enabled, the Cisco CMTS learns a MAC address the first time that the CPE device accesses the cable network. After the Cisco CMTS has logged the maximum number of MAC addresses specified by a MAX Host parameter, it drops all traffic from CPE devices that have any other MAC address.



---

**Tip** In DOCSIS 1.1 cable networks, when both the MAX CPE IP and MAX Host parameters are configured, the Cisco CMTS uses the lesser value to determine the maximum number of CPE devices that are allowed behind each cable modem. By default, MAX Host is set to 16.

---



---

**Note** The entire MAX Host address table is cleared whenever the Cisco TS is reset. You can also clear an entry for a particular CPE device using the **clear cable host** command.

---

## Specifying an Unlimited Value for Max Host

The **cable modem max-cpe** command, which affects all cable modems on the CMTS, supports the **unlimited** keyword, which specifies that the CMTS should not enforce any limit on CPE devices. When you configure the CMTS with the **unlimited keyword**, this setting, you are allowing cable modems to support any number of CPE devices.

Do not use the **unlimited** option without also specifying the proper value for MAX CPE in the DOCSIS configuration file, so that each cable modem can control the maximum number of CPE devices it supports. In addition, to prevent users from requesting an unlimited number of IP address, be sure to configure the DHCP servers so that they control how many IP addresses are assigned to the CPE devices behind each cable modem.

## MAX CPE IP

The MAX CPE IP parameter is applicable only in DOCSIS 1.1 cable networks and is an optional parameter. This parameter specifies whether the cable modem should perform IP address filtering on the CPE devices. If so, this attribute also specifies the maximum number of simultaneous IP addresses that are permitted behind the modem at any one time.

The MAX CPE IP parameter is configured in the DOCSIS configuration file (TLV 35), or by using SNMP commands to set the docsDevCpeIpMax attribute (in DOCS-CABLE-DEVICE-MIB) for the cable modem. By default, this parameter is not enabled and the Cisco CMTS does not actively manage CPE devices, unless you enable the use of the MAX CPE IP parameter by using the **cable submgmt default active** command. The **cable submgmt default max-cpe** command can be used to limit the number of IP addresses behind the cable modem.

If this feature is enabled, the cable modem learns the allowable IP addresses the first time that the CPE device sends an IP packet out into the network. The IP addresses are added to the docsDevFilterCpeTable table. This address table is cleared automatically when the cable modem is reset or powered off, or you can manually clear the IP address table by setting the docsSubMgtCpeControlReset attribute in the appropriate table entry for this cable modem.



---

**Tip** The CMTS uses the MAX CPE IP value as part of its own filtering process, but the two filters operate independently on the cable modem and CMTS.

---

## MAX CPE IPv6

The MAX CPE IPv6 parameter is an optional parameter and specifies the maximum number of simultaneous IPv6 addresses that are permitted for a cable modem at any time.

The MAX CPE IPv6 parameter is configured in the DOCSIS 3.0 configuration file (TLV 63), or by using the SNMP commands to set the docsSubmgmt3BaseCpeMaxIpv6PrefixDef attribute (in DOCS-SUBMGT3-MIB) for the cable modem. By default, this parameter is not enabled and the Cisco CMTS does not actively manage CPE devices, unless the use of the MAX CPE IPv6 parameter is enabled by using the **cable submgmt default active** command. The **cable submgmt default max-ipv6-cpe** command can be used to limit the number of IPv6 addresses allowed behind a cable modem.

When the MAX CPE IPv6 feature is enabled, the cable modem learns the allowable IPv6 addresses the first time that the CPE device sends an IPv6 packet out into the network. The IPv6 addresses are added to the IPv6 address table. The address table is cleared automatically when the cable modem is reset or powered off.

## Interoperation of the Maximum CPE Parameters

The different methods of CPE control can all be active simultaneously. They can interact with one another but do not conflict with one another. The table lists each method and compares their characteristics.

*Table 371: Comparison of the Different Max CPE and Max Host Control Mechanisms*

| CM Configuration Parameter | Function                                    | CMTS Equivalent                    | CMTS Enforcement Priority     |
|----------------------------|---------------------------------------------|------------------------------------|-------------------------------|
| Network Access Control     | Prevents all network access for CPE devices | Cable submgmt default learnable    | CMTS overrides CM Config File |
| MAX CPE                    | Limits MAC addresses per CM                 | Cable modem max-hosts              | Least restrictive is enforced |
| MAX CPE IP                 | Limits IP addresses per CM                  | Cable submgmt default max-cpe      | Most restrictive is enforced  |
| MAX CPE IPv6               | Limits IPv6 addresses per CM                | Cable submgmt default max-ipv6-cpe | Most restrictive is enforced  |

The table lists the MAX CPE parameters in order of priority. For example, the Network Access Control and MAX CPE parameters interact as follows:

- If the Network Access Control field for a cable modem is set to Disabled, none of that modem's CPE devices will be able to access the network, regardless of how the other parameters are set.
- If Network Access Control is Enabled and MAX CPE is set to 1 for a cable modem, then a maximum of one CPE device will be able to access the network, no matter how the remaining parameters are configured.

## Benefits

- CMTS flexibility allows multiple service operator provisioners, service providers, and other users to synchronize between the CMTS and the cable modem, the maximum number of CPE devices, maximum number of IPv4 addresses, and maximum number of IPv6 addresses that can be connected behind a cable modem.
- Changes can be made by using CLI commands or by using SNMP commands.

## How to Configure the MAX CPE and Host Parameters

To reset the maximum number of permitted CPE devices recognized by the CMTS, use one of the following configuration commands. All procedures are optional, depending on the requirements.



**Note** The CMTS assigns the MAX Host value to a cable modem at the time that the cable modem registers with the CMTS. Changing any of the MAX Host commands affects only cable modems that register after the change.

# Configuring the Maximum Number of CPE Devices on the Cisco CMTS

To configure the maximum number of CPE devices per cable modem, use the following procedure:

## Procedure

|        | Command or Action                                                                                                                            | Purpose                                                                                                                                                                                                                                                                                                                                                                                                                                                                                                                                                                                                                                                                                                                                                                                                                                                                                                                                                                                                             |
|--------|----------------------------------------------------------------------------------------------------------------------------------------------|---------------------------------------------------------------------------------------------------------------------------------------------------------------------------------------------------------------------------------------------------------------------------------------------------------------------------------------------------------------------------------------------------------------------------------------------------------------------------------------------------------------------------------------------------------------------------------------------------------------------------------------------------------------------------------------------------------------------------------------------------------------------------------------------------------------------------------------------------------------------------------------------------------------------------------------------------------------------------------------------------------------------|
| Step 1 | <p><b>enable</b></p> <p><b>Example:</b></p> <pre>Router&gt; enable</pre>                                                                     | <p>Enables privileged EXEC mode.</p> <ul style="list-style-type: none"> <li>• Enter your password if prompted.</li> </ul>                                                                                                                                                                                                                                                                                                                                                                                                                                                                                                                                                                                                                                                                                                                                                                                                                                                                                           |
| Step 2 | <p><b>configure terminal</b></p> <p><b>Example:</b></p> <pre>Router# configure terminal</pre>                                                | <p>Enters global configuration mode.</p>                                                                                                                                                                                                                                                                                                                                                                                                                                                                                                                                                                                                                                                                                                                                                                                                                                                                                                                                                                            |
| Step 3 | <p><b>cable modem max-cpe</b> [<i>number</i>   <b>unlimited</b>]</p> <p><b>Example:</b></p> <pre>Router(config)# cable modem max-cpe 8</pre> | <p>Sets the value of the MAX CPE parameter on the Cisco CMTS for all cable interfaces.</p> <p>The <b>show cable modem subscriber</b> displays the MAXIMUM value of cable modem max-cpe and the MAX CPE value in the DOCSIS configuration file of the cable modem.</p> <p>The number of the CPE that can be online is determined based on one of the following aspects:</p> <ul style="list-style-type: none"> <li>• If the number of the CPE is lower than the MAX CPE value in the DOCSIS configuration file of the cable modem, then the <b>cable modem max-cpe</b> command overrides the configuration file value.</li> <li>• If number of the CPE is higher than the MAX CPE value in the DOCSIS configuration file of the cable modem or is set as unlimited, then the value set in the configuration file takes precedence.</li> </ul> <p><b>Note</b> If the value in the configuration file is zero and <b>no cable modem max-cpe</b> is configured, then no CPE device is able to obtain an IP address.</p> |
| Step 4 | <p><b>cable submgmt default active</b></p> <p><b>Example:</b></p> <pre>Router(config)# cable submgmt default active</pre>                    | <p>Specifies that the CMTS should actively manage CPE devices. The default is the <b>no</b> version of this command, so that the CMTS does not actively manage CPE devices.</p>                                                                                                                                                                                                                                                                                                                                                                                                                                                                                                                                                                                                                                                                                                                                                                                                                                     |
| Step 5 | <p><b>cable submgmt default max-cpe</b> <i>cpe-ip</i></p> <p><b>Example:</b></p>                                                             | <p>(Optional) Specifies the default value for the MAX CPE IP.</p>                                                                                                                                                                                                                                                                                                                                                                                                                                                                                                                                                                                                                                                                                                                                                                                                                                                                                                                                                   |

|               | Command or Action                                                                                                                    | Purpose                                                      |
|---------------|--------------------------------------------------------------------------------------------------------------------------------------|--------------------------------------------------------------|
|               | Router(config)# cable submgmt default max-cpe 4                                                                                      |                                                              |
| <b>Step 6</b> | <b>cable submgmt default max-ipv6-cpe <i>ipv6-num</i></b><br><b>Example:</b><br>Router(config)# cable submgmt default max-ipv6-cpe 4 | (Optional) Specifies the default value for the MAX IPv6 CPE. |
| <b>Step 7</b> | <b>exit</b><br><b>Example:</b><br>Router(config)# exit                                                                               | Exits global configuration mode.                             |

### What to do next



**Note** Use of the **cable modem max-cpe unlimited** command can open a security hole in the system by enabling denial of service attacks. It could allow a single user to obtain a large number of IP addresses, and thereby cause the entire network to go down after this single user has reserved all available IP addresses.

## Configuration Examples

To display the current configuration and status of a cable interface, use the **show running-config** command in privileged EXEC mode. The following is sample output that shows that the CMTS permits up to five CPE devices to use the specified cable interface to pass traffic.

```
interface Cable3/0
ip address 192.168.1.1 255.255.255.0 secondary
ip address 10.1.1.1 255.255.255.0
load-interval 30
no keepalive
cable downstream annex B
cable downstream modulation 256qam
cable downstream interleave-depth 32
cable downstream frequency 507000000
cable upstream 0 frequency 27008000
cable upstream 0 power-level 0
cable upstream 0 minislots-size 32
cable upstream 0 modulation-profile 2
no cable upstream 0 shutdown
cable upstream 1 frequency 29008000
cable upstream 1 power-level 0
cable upstream 1 channel-width 320000
cable upstream 1 minislots-size 4
no cable upstream 1 shutdown
cable dhcp-giaddr policy
```

```
cable helper-address 172.17.110.131
end
```

You can also use the **more system:running-config** command to verify the maximum number of permitted CPE devices for a cable interface.

```
CMTS01# more system:running-config
Building configuration...
Current configuration:
!
interface Cable6/0
 ip address 10.1.1.1 255.255.255.0
 no keepalive
 cable insertion-interval 2000
 cable downstream annex B
 cable downstream modulation 64qam
 cable downstream interleave-depth 32
 cable downstream symbol-rate 5056941
 cable upstream 0 frequency 15008000
 cable upstream 0 fec
 cable upstream 0 scrambler
 no cable upstream 0 shutdown
```

## Additional References

For additional information related to configuring the MAX CPE and Host parameters on the Cisco CMTS, refer to the following references:

### Related Documents

| Related Topic                     | Document Title                                                   |
|-----------------------------------|------------------------------------------------------------------|
| Cisco CMTS Commands               | <a href="#">Cisco CMTS Cable Command Reference</a>               |
| Interaction of MAX CPE Parameters | <a href="#">Using the max-cpe Command in the DOCSIS and CMTS</a> |

### Standards

| Standards <sup>18</sup>               | Title                                                                                                                                                                                                     |
|---------------------------------------|-----------------------------------------------------------------------------------------------------------------------------------------------------------------------------------------------------------|
| <a href="#">SP-RFIV1.1-I08-020301</a> | <i>Data-Over-Cable Service Interface Specifications Radio Frequency Interface Specification , version 1.1</i> ( <a href="http://www.cablelabs.com/cablemodem/">http://www.cablelabs.com/cablemodem/</a> ) |

<sup>18</sup> Not all supported standards are listed.

### MIBs

| MIBs <sup>19</sup>                                           | MIBs Link                                                                                                                                                                                                                       |
|--------------------------------------------------------------|---------------------------------------------------------------------------------------------------------------------------------------------------------------------------------------------------------------------------------|
| DOCS-CABLE-DEVICE-MIB<br>DOCS-SUBMGT-MIB<br>DOCS-SUBMGT3-MIB | To locate and download MIBs for selected platforms, Cisco software releases, and feature sets, use Cisco MIB Locator found at the following URL:<br><br><a href="http://www.cisco.com/go/mibs">http://www.cisco.com/go/mibs</a> |

<sup>19</sup> Not all supported MIBs are listed.

**Technical Assistance**

| Description                                                                                                                                                                                                                                                                                                                                                                           | Link                                                                                                              |
|---------------------------------------------------------------------------------------------------------------------------------------------------------------------------------------------------------------------------------------------------------------------------------------------------------------------------------------------------------------------------------------|-------------------------------------------------------------------------------------------------------------------|
| The Cisco Support and Documentation website provides online resources to download documentation, software, and tools. Use these resources to install and configure the software and to troubleshoot and resolve technical issues with Cisco products and technologies. Access to most tools on the Cisco Support and Documentation website requires a Cisco.com user ID and password. | <a href="http://www.cisco.com/cisco/web/support/index.html">http://www.cisco.com/cisco/web/support/index.html</a> |

## Feature Information for Maximum CPE and Host Parameters

Use Cisco Feature Navigator to find information about the platform support and software image support. Cisco Feature Navigator enables you to determine which software images support a specific software release, feature set, or platform. To access Cisco Feature Navigator, go to the <https://cfngn.cisco.com/> link. An account on the Cisco.com page is not required.



**Note** The following table lists the software release in which a given feature is introduced. Unless noted otherwise, subsequent releases of that software release train also support that feature.

*Table 372: Feature Information for Maximum CPE and Host Parameters*

| Feature Name                    | Releases                    | Feature Information                                                                                               |
|---------------------------------|-----------------------------|-------------------------------------------------------------------------------------------------------------------|
| Maximum CPE and Host Parameters | Cisco IOS XE Everest 16.6.1 | This feature was integrated into Cisco IOS XE Everest 16.6.1 on the Cisco cBR Series Converged Broadband Routers. |





## CHAPTER 117

# SNMP Background Synchronization

The SNMP Background Synchronization features provides periodic background synchronization of DOCSIS MIB data from line card to Supervisor in order to improve the performance of the SNMP polling of these MIB tables.

Your software release may not support all the features that are documented in this module. For the latest feature information and caveats, see the release notes for your platform and software release. The Feature Information Table at the end of this document provides information about the documented features and lists the releases in which each feature is supported.

Use Cisco Feature Navigator to find information about platform support and Cisco software image support. To access Cisco Feature Navigator, go to <http://tools.cisco.com/ITDIT/CFN/>. An account on <http://www.cisco.com/> is not required.

### Contents

- [Information About SNMP Background Synchronization, on page 1885](#)
- [How to Configure SNMP Background Synchronization, on page 1887](#)
- [Configuring Example for SNMP Background Synchronization, on page 1894](#)
- [Channel Utilization Consistency, on page 1894](#)
- [Feature Information for SNMP Background Synchronization, on page 1896](#)

## Information About SNMP Background Synchronization

*Table 373: Feature History*

| Feature Name                                       | Release Information          | Feature Description                                                                                                                                                                                                   |
|----------------------------------------------------|------------------------------|-----------------------------------------------------------------------------------------------------------------------------------------------------------------------------------------------------------------------|
| New MIB tables for SNMP background synchronization | Cisco IOS XE Dublin 17.12.1w | The following MIB tables are added to the SNMP background synchronization: <ul style="list-style-type: none"><li>• ccwbRFChannelEntry</li><li>• docsIfUpstreamChannelEntry</li><li>• cdxIfUpChannelExtEntry</li></ul> |

To improve SNMP performance, SNMP background synchronization feature is introduced to synchronize the SNMP MIB information between the line card and the Supervisor. It is based on raw socket and uses TCP protocol. The benefits of the SNMP Background Synchronization include:

- Bundles small packets together before sending out, increases IPC channel utilization.
- Use pre-allocated static buffer to send/receive message, avoid buffer allocation at run time.
- In order not to burden CPU when the system is in high load, SNMP background synchronization receive process can sleep based on CPU utilization, so it will not compete with other priority processes.
- Significantly improve SNMP polling performance for supported MIB tables, and reduce the CPU utilization in both Supervisor and line card.
- Background synchronization sets up a separate socket connection between SUP and IOSd-CLC, and periodically syncs the SNMP data from IOSd-clc to SUP. When SNMP requests arrives, SUP returns the synced data directly to the SNMP client instead of using IPC to retrieve data from IOSd-CLC. Thus, the response time is reduced.

The following MIB tables are supported in SNMP background synchronization:

- docsQosParamSetEntry
- docsIetfQosParamSetEntry
- docsQos3ParamSetEntry
- docsIf3CmtsCmUsStatusEntry
- docsIfCmtsCmStatusEntry
- docsSubMgtCpeControlEntry
- docsSubMgtCmFilterEntry
- cdxCmtsCmStatusExtEntry
- docsLoadBalCmtsCmStatusEntry
- docsIf3CmtsCmRegStatusTable
- docsIfSignalQualityTable
- docsifCmtsServiceTable
- cdxCmtsServiceExtEntry
- ccwbRFChannelEntry
- docsIfUpstreamChannelEntry
- cdxIfUpChannelExtEntry

# How to Configure SNMP Background Synchronization

## Enabling SNMP Background Synchronization

### Before you begin

To use the **cable bgsync** command, you must configure the **service internal** command in global configuration mode.

SNMP background synchronization is enabled by default, use **no cable bgsync active** to disable this feature, and use **cable bgsync active** to enable it again. The following procedure lists detailed steps to enable SNMP background synchronization:

```
enable
configure terminal
cable bgsync active
exit
```

## Setting Data Interval

### Before you begin

To use the **cable bgsync** command, you must configure the **service internal** command in global configuration mode. Use the **cable bgsync** command carefully as it can impact the CPU utilization.

To set the data intervals for the background synchronization of SNMP MIB data on the Cisco cBR routers, use the **cable bgsync {itime *i-interval*|ptime *p-interval*}** command in global configuration mode. To disable background synchronization, use the **no** form of this command. The following procedure lists detailed steps to set data interval:

```
enable
configure terminal
service internal
cable bgsync itime i-interval
cable bgsync ptime p-interval
exit
```

**itime** is the interval of synchronizing all related MIB tables from line card to Supervisor. The valid range is from 5 to 31536000. The default value is 86400. **ptime** is the interval of synchronizing the changed MIB content from line card to Supervisor.

## Verifying SNMP Background Synchronization

- To display the current status of the SNMP background synchronization, use the **show cable bgsync** command as shown in the example below:

```
Router#show cable bgsync
Background Sync is active, uptime is 5 minutes, 14 seconds.
Background Sync last active time is 5 minutes, 14 seconds. ago.
I-packet interval time is 1 day, P-packet interval time is 5 seconds.
Line Card with bg-sync: 3/0
Line Card working on I syncing:
```

```

Last clear cable bg sync counters Time:
Total bytes: 85864
Total background sync packets: 2109
  Ack packets: 0
  Run Ctrl Msg packets: 2
  Data packets: 0
Interval packets: 2002
  I Type packets: 230
  P Type packets: 1772
Bg sync data IPC lost packets: 0
    
```

Background Sync statistics for the last 00:07:34

```

=====
ipc packets 0-30k:      105
ipc packets 30-60k:    0
ipc packets 60-100k:  0
msg per packet average: 20
msg per packet max:   113
msg per packet min:   1
msg per packet under 3: 60
    
```

```

=====
type      packets      cpu-total(ms)  avg(us)  max(us)
serv flow  904              3             3         1000
sflog     0                0             0         0
cm        17              0             0         0
cmtx     296              0             0         0
paramset  112              0             0         0
DXIF     298              0             0         0
sid      208              0             0         0
uschan   167              1             5         1000
    
```

```

-----
IPC PKTs  105          4          0      ms 1      ms
    
```

```

=====
slot type      packets      bytes      pps      Bps      wrong_len_pkts
0   serv flow  0            0          0.0      0.0      0
0   sflog     0            0          0.0      0.0      0
0   cm        0            0          0.0      0.0      0
0   cmtx     0            0          0.0      0.0      0
0   paramset  0            0          0.0      0.0      0
0   DXIF     0            0          0.0      0.0      0
0   sid      0            0          0.0      0.0      0
0   uschan   0            0          0.0      0.0      0
1   serv flow  0            0          0.0      0.0      0
1   sflog     0            0          0.0      0.0      0
1   cm        0            0          0.0      0.0      0
1   cmtx     0            0          0.0      0.0      0
1   paramset  0            0          0.0      0.0      0
1   DXIF     0            0          0.0      0.0      0
1   sid      0            0          0.0      0.0      0
    
```

|   |           |     |       |     |       |   |
|---|-----------|-----|-------|-----|-------|---|
| 1 | uschan    | 0   | 0     | 0.0 | 0.0   | 0 |
| 2 | serv flow | 0   | 0     | 0.0 | 0.0   | 0 |
| 2 | sflog     | 0   | 0     | 0.0 | 0.0   | 0 |
| 2 | cm        | 0   | 0     | 0.0 | 0.0   | 0 |
| 2 | cmtx      | 0   | 0     | 0.0 | 0.0   | 0 |
| 2 | paramset  | 48  | 7680  | 0.0 | 0.0   | 0 |
| 2 | DXIF      | 0   | 0     | 0.0 | 0.0   | 0 |
| 2 | sid       | 16  | 512   | 0.0 | 0.0   | 0 |
| 2 | uschan    | 0   | 0     | 0.0 | 0.0   | 0 |
| 3 | serv flow | 904 | 25104 | 4.4 | 115.4 | 0 |
| 3 | sflog     | 0   | 0     | 0.0 | 0.0   | 0 |
| 3 | cm        | 17  | 981   | 0.0 | 2.0   | 0 |
| 3 | cmtx      | 296 | 8607  | 0.7 | 20.6  | 0 |
| 3 | paramset  | 64  | 8368  | 0.0 | 0.0   | 0 |
| 3 | DXIF      | 298 | 21876 | 0.9 | 74.3  | 0 |
| 3 | sid       | 192 | 4756  | 0.1 | 6.8   | 0 |
| 3 | uschan    | 167 | 5832  | 0.3 | 10.7  | 0 |
| 6 | serv flow | 0   | 0     | 0.0 | 0.0   | 0 |
| 6 | sflog     | 0   | 0     | 0.0 | 0.0   | 0 |
| 6 | cm        | 0   | 0     | 0.0 | 0.0   | 0 |
| 6 | cmtx      | 0   | 0     | 0.0 | 0.0   | 0 |
| 6 | paramset  | 0   | 0     | 0.0 | 0.0   | 0 |
| 6 | DXIF      | 0   | 0     | 0.0 | 0.0   | 0 |
| 6 | sid       | 0   | 0     | 0.0 | 0.0   | 0 |
| 6 | uschan    | 0   | 0     | 0.0 | 0.0   | 0 |
| 7 | serv flow | 0   | 0     | 0.0 | 0.0   | 0 |
| 7 | sflog     | 0   | 0     | 0.0 | 0.0   | 0 |
| 7 | cm        | 0   | 0     | 0.0 | 0.0   | 0 |
| 7 | cmtx      | 0   | 0     | 0.0 | 0.0   | 0 |
| 7 | paramset  | 0   | 0     | 0.0 | 0.0   | 0 |
| 7 | DXIF      | 0   | 0     | 0.0 | 0.0   | 0 |
| 7 | sid       | 0   | 0     | 0.0 | 0.0   | 0 |

|   |           |   |   |     |     |   |
|---|-----------|---|---|-----|-----|---|
| 7 | uschan    | 0 | 0 | 0.0 | 0.0 | 0 |
| 8 | serv flow | 0 | 0 | 0.0 | 0.0 | 0 |
| 8 | sflog     | 0 | 0 | 0.0 | 0.0 | 0 |
| 8 | cm        | 0 | 0 | 0.0 | 0.0 | 0 |
| 8 | cmtx      | 0 | 0 | 0.0 | 0.0 | 0 |
| 8 | paramset  | 0 | 0 | 0.0 | 0.0 | 0 |
| 8 | DXIF      | 0 | 0 | 0.0 | 0.0 | 0 |
| 8 | sid       | 0 | 0 | 0.0 | 0.0 | 0 |
| 8 | uschan    | 0 | 0 | 0.0 | 0.0 | 0 |
| 9 | serv flow | 0 | 0 | 0.0 | 0.0 | 0 |
| 9 | sflog     | 0 | 0 | 0.0 | 0.0 | 0 |
| 9 | cm        | 0 | 0 | 0.0 | 0.0 | 0 |
| 9 | cmtx      | 0 | 0 | 0.0 | 0.0 | 0 |
| 9 | paramset  | 0 | 0 | 0.0 | 0.0 | 0 |
| 9 | DXIF      | 0 | 0 | 0.0 | 0.0 | 0 |
| 9 | sid       | 0 | 0 | 0.0 | 0.0 | 0 |
| 9 | uschan    | 0 | 0 | 0.0 | 0.0 | 0 |

- To display all the SNMP background sync data on Supervisor side or line card side, use the **show cable bgsync sync-info cable** command as shown in the example below:

```
Router#show cable bgsync sync-info cable 9/0/1
  part1 for srv template:
  srv_tmp_id  min_rate  max_rate  max_burst
  0            0          0          0
  1            0          64000     0
  2            0          1000000   0
  3            0          1000000   3044
  4            0          0          3044
  5            0          11000000  30000
  6            0          0          3044
  7            0          200000000 5000000
  8            0          0          3044
  part2 for srv flow:
  sfid      prov_qos  adm_qos  act_qos  wb_mode  octets  pkts  delay_pkts
  drop_pkts gate_id   create_time  total_active_time
  1         0         0         0         0         0         0         0
  0         0         0         0         0         0         0         0
  2         0         0         0         0         0         0         0
  0         0         0         0         0         0         0         0
  3         0         0         0         0         0         0         0
  0         0         0         0         0         0         0         0
  4         0         0         0         0         0         0         0
  0         0         0         0         0         0         0         0
  5         0         0         0         0         0         0         0
  0         0         0         0         0         0         0         0
```

|    |   |   |       |   |     |      |    |   |
|----|---|---|-------|---|-----|------|----|---|
| 6  | 0 | 0 | 0     | 0 | 0   | 0    | 0  | 0 |
| 0  | 0 |   | 0     |   | 0   |      |    |   |
| 7  | 0 | 0 | 0     | 0 | 0   | 0    | 0  | 0 |
| 0  | 0 |   | 0     |   | 0   |      |    |   |
| 8  | 0 | 0 | 0     | 0 | 0   | 0    | 0  | 0 |
| 0  | 0 |   | 0     |   | 0   |      |    |   |
| 9  | 0 | 0 | 0     | 0 | 0   | 0    | 0  | 0 |
| 0  | 0 |   | 0     |   | 0   |      |    |   |
| 10 | 0 | 0 | 0     | 0 | 0   | 0    | 0  | 0 |
| 0  | 0 |   | 0     |   | 0   |      |    |   |
| 11 | 0 | 0 | 0     | 0 | 0   | 0    | 0  | 0 |
| 0  | 0 |   | 0     |   | 0   |      |    |   |
| 12 | 0 | 0 | 0     | 0 | 0   | 0    | 0  | 0 |
| 0  | 0 |   | 0     |   | 0   |      |    |   |
| 13 | 0 | 0 | 0     | 0 | 0   | 0    | 0  | 0 |
| 0  | 0 |   | 0     |   | 0   |      |    |   |
| 14 | 0 | 0 | 0     | 0 | 0   | 0    | 0  | 0 |
| 0  | 0 |   | 0     |   | 0   |      |    |   |
| 15 | 3 | 3 |       | 3 | 0   | 0    | 0  | 0 |
| 0  | 0 |   | 3600  |   | 179 |      |    |   |
| 16 | 3 | 3 |       | 3 | 0   | 0    | 0  | 0 |
| 0  | 0 |   | 3600  |   | 179 |      |    |   |
| 17 | 3 | 3 |       | 3 | 0   | 0    | 0  | 0 |
| 0  | 0 |   | 3600  |   | 179 |      |    |   |
| 18 | 3 | 3 |       | 3 | 0   | 0    | 0  | 0 |
| 0  | 0 |   | 3600  |   | 179 |      |    |   |
| 19 | 3 | 3 |       | 3 | 0   | 0    | 0  | 0 |
| 0  | 0 |   | 3600  |   | 179 |      |    |   |
| 20 | 3 | 3 |       | 3 | 0   | 0    | 0  | 0 |
| 0  | 0 |   | 3600  |   | 179 |      |    |   |
| 21 | 3 | 3 |       | 3 | 0   | 0    | 0  | 0 |
| 0  | 0 |   | 3600  |   | 179 |      |    |   |
| 22 | 3 | 3 |       | 3 | 0   | 0    | 0  | 0 |
| 0  | 0 |   | 3600  |   | 179 |      |    |   |
| 23 | 3 | 3 |       | 3 | 0   | 0    | 0  | 0 |
| 0  | 0 |   | 3600  |   | 179 |      |    |   |
| 24 | 3 | 3 |       | 3 | 0   | 0    | 0  | 0 |
| 0  | 0 |   | 3600  |   | 179 |      |    |   |
| 25 | 3 | 3 |       | 3 | 0   | 0    | 0  | 0 |
| 0  | 0 |   | 3600  |   | 179 |      |    |   |
| 26 | 3 | 3 |       | 3 | 0   | 0    | 0  | 0 |
| 0  | 0 |   | 3600  |   | 179 |      |    |   |
| 27 | 4 | 5 |       | 5 | 0   | 8925 | 42 | 0 |
| 0  | 0 |   | 12700 |   | 88  |      |    |   |
| 28 | 6 | 7 |       | 7 | 3   | 0    | 0  | 0 |
| 0  | 0 |   | 12700 |   | 88  |      |    |   |
| 29 | 4 | 5 |       | 5 | 3   | 3855 | 21 | 0 |
| 0  | 0 |   | 11500 |   | 100 |      |    |   |
| 30 | 6 | 7 |       | 7 | 3   | 0    | 0  | 0 |
| 0  | 0 |   | 11500 |   | 100 |      |    |   |
| 31 | 8 | 8 |       | 8 | 3   | 222  | 3  | 0 |
| 0  | 0 |   | 11500 |   | 100 |      |    |   |
| 32 | 4 | 5 |       | 5 | 3   | 1277 | 11 | 0 |
| 0  | 0 |   | 12100 |   | 94  |      |    |   |
| 33 | 6 | 7 |       | 7 | 0   | 0    | 0  | 0 |
| 0  | 0 |   | 12100 |   | 94  |      |    |   |
| 34 | 4 | 5 |       | 5 | 0   | 3851 | 21 | 0 |
| 0  | 0 |   | 12300 |   | 92  |      |    |   |
| 35 | 6 | 7 |       | 7 | 3   | 0    | 0  | 0 |
| 0  | 0 |   | 12300 |   | 92  |      |    |   |
| 36 | 8 | 8 |       | 8 | 0   | 148  | 2  | 0 |
| 0  | 0 |   | 12100 |   | 94  |      |    |   |
| 37 | 4 | 5 |       | 5 | 0   | 3855 | 21 | 0 |
| 0  | 0 |   | 12700 |   | 88  |      |    |   |

```

38      6      7      7      3      0      0      0
0      0
39      8      8      8      3      222      3      0
0      0
40      4      5      5      3      3281      20      0
0      0
41      6      7      7      3      0      0      0
0      0
42      8      8      8      3      222      3      0
0      0
43      8      8      8      3      222      3      0
0      0
44      4      5      5      3      3308      21      0
0      0
45      6      7      7      3      0      0      0
0      0
46      8      8      8      3      296      4      0
0      0
47      8      8      8      3      296      4      0
0      0
48      4      5      5      3      73      2      0
0      0
49      6      7      7      3      0      0      0
0      0
50      8      8      8      3      74      1      0
0      0

```

part3 for sid

```

sid_entry[1] sid 1 service_class 2 create_time 127 total_octets 8925
sid_entry[2] sid 2 service_class 2 create_time 115 total_octets 3855
sid_entry[3] sid 3 service_class 2 create_time 121 total_octets 1277
sid_entry[4] sid 4 service_class 2 create_time 123 total_octets 3851
sid_entry[5] sid 5 service_class 2 create_time 127 total_octets 3855
sid_entry[6] sid 6 service_class 2 create_time 131 total_octets 3281
sid_entry[7] sid 7 service_class 2 create_time 131 total_octets 3308
sid_entry[8] sid 8 service_class 2 create_time 145 total_octets 73

```

part4 for cm and cmtx

```

cm_mac: 68ee.9633.0699, tcsbmp: 0x1, admin_status 1, md_sg_id 0x1510505, rcc_status_id
0x4, rcs_id 0x1520005, tcs_id 0x1 last_reg_time 1444372688, RCP ID:00 10 00 00 10
usch 1, modulation_type 2, rx_power -5, signal_noise 390, time_offset 2085
cm_mac: e448.c70c.96e7, tcsbmp: 0x4, admin_status 1, md_sg_id 0x1510505, rcc_status_id
0x4, rcs_id 0x1520005, tcs_id 0x3 last_reg_time 1444372678, RCP ID:00 10 00 00 08
usch 3, modulation_type 2, rx_power -15, signal_noise 381, time_offset 1785
cm_mac: 0019.474a.c126, tcsbmp: 0x1, admin_status 1, md_sg_id 0x1510505, rcc_status_id
0x0, rcs_id 0x22, tcs_id 0x1 last_reg_time 1444372682, RCP ID:00 00 00 00 00
usch 1, modulation_type 2, rx_power -15, signal_noise 390, time_offset 1792
cm_mac: e448.c70c.982b, tcsbmp: 0x1, admin_status 1, md_sg_id 0x1510505, rcc_status_id
0x4, rcs_id 0x1520005, tcs_id 0x1 last_reg_time 1444372685, RCP ID:00 10 00 00 08
usch 1, modulation_type 2, rx_power -10, signal_noise 390, time_offset 1786
cm_mac: e448.c70c.96d5, tcsbmp: 0x2, admin_status 1, md_sg_id 0x1510505, rcc_status_id
0x4, rcs_id 0x1520005, tcs_id 0x2 last_reg_time 1444372688, RCP ID:00 10 00 00 08
usch 2, modulation_type 2, rx_power -15, signal_noise 381, time_offset 1786
cm_mac: e448.c70c.9819, tcsbmp: 0x1, admin_status 1, md_sg_id 0x1510505, rcc_status_id
0x4, rcs_id 0x1520005, tcs_id 0x1 last_reg_time 1444372692, RCP ID:00 10 00 00 08
usch 1, modulation_type 2, rx_power -10, signal_noise 390, time_offset 1789
cm_mac: e448.c70c.980d, tcsbmp: 0x4, admin_status 1, md_sg_id 0x1510505, rcc_status_id
0x4, rcs_id 0x1520005, tcs_id 0x3 last_reg_time 1444372695, RCP ID:00 10 00 00 08
usch 3, modulation_type 2, rx_power -10, signal_noise 390, time_offset 1783
cm_mac: e448.c70c.96f3, tcsbmp: 0x1, admin_status 1, md_sg_id 0x1510505, rcc_status_id
0x4, rcs_id 0x1520005, tcs_id 0x1 last_reg_time 1444372723, RCP ID:00 10 00 00 04
usch 1, modulation_type 2, rx_power 0, signal_noise 420, time_offset 1798

```

part5 for dxif info ifnum 1

```

basedata[1][1]: cmstatusindex 2375681, cm_mac 68ee.9633.0699, cm_ip 0x5011961F, cm_ds_if
59881, cm_us_if 204952
cmregmode 2, cmmodulype 2, cmdocmode 2

```



```

basedata[1][2]: cmstatusindex 2375682, cm_mac e448.c70c.96e7, cm_ip 0x5011961D, cm_ds_if
59882, cm_us_if 204954
cmregmode 2, cmmodultype 2, cmdocmode 2
basedata[1][3]: cmstatusindex 2375683, cm_mac 0019.474a.c126, cm_ip 0x50119602, cm_ds_if
59914, cm_us_if 204952
cmregmode 2, cmmodultype 2, cmdocmode 2
basedata[1][4]: cmstatusindex 2375684, cm_mac e448.c70c.982b, cm_ip 0x50119612, cm_ds_if
59881, cm_us_if 204952
cmregmode 2, cmmodultype 2, cmdocmode 2
basedata[1][5]: cmstatusindex 2375685, cm_mac e448.c70c.96d5, cm_ip 0x5011960D, cm_ds_if
59881, cm_us_if 204953
cmregmode 2, cmmodultype 2, cmdocmode 2
basedata[1][6]: cmstatusindex 2375686, cm_mac e448.c70c.9819, cm_ip 0x5011961E, cm_ds_if
59881, cm_us_if 204952
cmregmode 2, cmmodultype 2, cmdocmode 2
basedata[1][7]: cmstatusindex 2375687, cm_mac e448.c70c.980d, cm_ip 0x5011961A, cm_ds_if
59882, cm_us_if 204954
cmregmode 2, cmmodultype 2, cmdocmode 2
basedata[1][8]: cmstatusindex 2375688, cm_mac e448.c70c.96f3, cm_ip 0x5011960E, cm_ds_if
59882, cm_us_if 204952
cmregmode 2, cmmodultype 2, cmdocmode 2
part6 uschan for ifnum 1
usport 1 micro_reflections 0 us_snr 390 snmp_sigq_unerroreds 0 snmp_sigq_correcteds 0
snmp_sigq_uncorrectables 0
usport 2 micro_reflections 0 us_snr 381 snmp_sigq_unerroreds 0 snmp_sigq_correcteds 0
snmp_sigq_uncorrectables 0
usport 3 micro_reflections 0 us_snr 390 snmp_sigq_unerroreds 0 snmp_sigq_correcteds 0
snmp_sigq_uncorrectables 0
usport 4 micro_reflections 0 us_snr 0 snmp_sigq_unerroreds 0 snmp_sigq_correcteds 0
snmp_sigq_uncorrectables 0
    
```

- To display raw socket interprocess communication (IPC) infrastructure statistics for specified field replaceable unit (FRU), use the **show platform software ios slot-id socket statistics** command as shown in the example below:

```
Router#show platform software ios R0 socket statistics 0
```

```

-----
Session Slot          : 2
Socket FD             : 93
Client ID             : 0
Message Receive Count : 0
Message Receive Bytes : 0
    
```

```

-----
Session Slot          : 2
Socket FD             : 93
Client ID             : 1
Message Receive Count : 30155
Message Receive Bytes : 1326820
    
```

```

-----
Session Slot          : 3
Socket FD             : 86
Client ID             : 0
Message Receive Count : 0
Message Receive Bytes : 0
    
```

```

-----
Session Slot          : 3
    
```

```

Socket FD           : 86
Client ID          : 1
Message Receive Count : 29611
Message Receive Bytes : 69782901
    
```

## Configuring Example for SNMP Background Synchronization

The following example shows how to configure SNMP background synchronization:

```

enable
configure terminal
cable bgsync active
service internal
cable bgsync itime 200
cable bgsync ptime 500
exit
    
```

## Channel Utilization Consistency

Table 374: Feature History

| Feature Name                    | Release Information          | Feature Description                                                                                                                                                                                                                                                                                                                                                                                                                                                                                                                                                                                                               |
|---------------------------------|------------------------------|-----------------------------------------------------------------------------------------------------------------------------------------------------------------------------------------------------------------------------------------------------------------------------------------------------------------------------------------------------------------------------------------------------------------------------------------------------------------------------------------------------------------------------------------------------------------------------------------------------------------------------------|
| Channel Utilization Consistency | Cisco IOS XE Dublin 17.12.1y | <p>We have enhanced <b>docsIf31CmtsDsOfdmChanUtilization</b> and <b>docsIfCmtsChannelUtUtilization</b> MIBS to calculate a rolling average utilization. The utilization calculation window is specified by the operator using the <b>cable util-interval</b> command.</p> <p>With this release, you can observe consistency in the Upstream and Downstream SCQAM/OFDMA Channel utilization and MIB data.</p> <p>We have also updated the output of the <b>show controllers downstream-cable slot/subslot/port [counter rf-channel   counter ofdm-channel] snmp-rolling-avg</b> command to include the rolling average values.</p> |

In releases prior to Cisco IOS XE Dublin 17.12.1y, the Downstream SCQAM/OFDM Channel utilization calculation and MIB data was inconsistent with Upstream SCQAM/OFDMA Channels. Upstream SCQAM/OFDMA utilization calculation computes the rolling average for Channel utilization. But the Downstream SCQAM utilization calculation did not compute rolling average for Channel utilization.

- Though the Downstream OFDM utilization calculation computes a rolling average, it displays only one sample value of the channel utilization when **docsIf31CmtsDsOfdmChanUtilization** MIB object is queried.
- The MIB data refresh rate is not 30 seconds. After changing the **cable-util-interval** value, Downstream OFDM samples data are not cleared.

- Hence, to be consistent with the upstream Channels Computation, rolling average calculation is implemented for Downstream SCQAM/OFDM Channels in Cisco IOS XE Dublin 17.12.1y.

The benefit of maintaining consistency between Upstream and Downstream Channel utilization and MIB data is that you don't observe different behaviors in Upstream and Downstream utilization.

### Rolling Average Calculation for Downstream OFDM and SCQAM Channel Utilization

In previous releases, the rolling average for Downstream OFDM Channel Utilization can be configured using the window size (total number of channel utilization samples). The window size is calculated using the configured value of the `cable-util-interval` command or SNMP manager. This configuration stores sample values for **all** the OFDM channels. The max window size supported was 1000 seconds. All OFDM channel (1000 sec / 5 interval) 200 sample data memory was allocated.

Starting with Cisco IOS XE Dublin 17.12.1y, values are only stored for the configured OFDM channels. The `cable-util-interval` command value is used to compute the rolling average value. To reduce memory usage, we are allocating memory dynamically for configured channels only. For example, if `cable-util-interval` is 300 sec then (300 / 5), then only 60 sample data memory is allocated.

In addition to configuring the value using the MIB object `docsIfCmtsChannelUtilizationInterval`, you can also configure the command via CLI. A fixed 5-seconds interval (Sample size or Sample Interval) is used to collect Channel utilization samples. A window size (Number of channel utilization samples) is calculated based on the `cable-util-interval` value as follows:

#### Window Size = cable-util-interval / Sample-Interval

The following example shows how the rolling average is calculated:

```
cable-util-interval: 100 seconds
Sample-Interval or Sample size (Interval at which channel utilization samples are collected):
 5 seconds
Window size (Total number of channel utilization samples) = cable-util-interval/sample size
= 100/5 = 20
```

Each 5-second sample is stored in an array and the rolling average is computed using the samples that are collected.

In the preceding example if we consider the first 5 samples that are collected are 10%, 20%, 30%, 30% and 10%, then the rolling average computed would be as below:

At the 5th second interval:  $10 / 20 = 0.5$  - rounded of to **0**.

At the 10th second interval:  $(10+20) / 20 = 1.5$  - rounded of to **1**.

At the 15th second interval:  $(10+20+30) / 20 = 3$

At the 20th second interval:  $(10+20+30+30) / 20 = 4.5$  - rounded of to **4**.

At the 25th second interval:  $(10+20+30+30+10) / 20 = 5.0$



- Note** In Cisco IOS XE Dublin 17.12.1y and later,
- The maximum supported value is 2000 seconds. If you configure a value greater than 2000 seconds, it is still considered as 2000 seconds. This is because the maximum supported value for the utilization interval of **downstream** channels is 2000. (Maximum supported value for the utilization interval for **upstream** channels remains to be 86400 seconds).
  - The **docsIf31CmtsDsOfdmChanUtilization** and **docsIfCmtsChannelUtUtilization** MIBs refresh rate is 30 seconds. If the interval value is less than 30 seconds, then the **docsIfCmtsChannelUtUtilization** MIB value is updated as per the configured **cable util interval**. For example if **cable util interval** is configured as 10 seconds, then the MIB is updated every 10 seconds.

## Feature Information for SNMP Background Synchronization

Use Cisco Feature Navigator to find information about the platform support and software image support. Cisco Feature Navigator enables you to determine which software images support a specific software release, feature set, or platform. To access Cisco Feature Navigator, go to the <https://cfng.cisco.com/> link. An account on the Cisco.com page is not required.



- Note** The following table lists the software release in which a given feature is introduced. Unless noted otherwise, subsequent releases of that software release train also support that feature.

**Table 375: Feature Information for SNMP Background Synchronization**

| Feature Name                    | Releases                    | Feature Information                                                                                               |
|---------------------------------|-----------------------------|-------------------------------------------------------------------------------------------------------------------|
| SNMP Background Synchronization | Cisco IOS XE Everest 16.6.1 | This feature was integrated into Cisco IOS XE Everest 16.6.1 on the Cisco cBR Series Converged Broadband Routers. |



## CHAPTER 118

# Online Offline Diagnostics

Online Offline Diagnostics (OOD) Field Diagnostics feature allows the customer to test and verify hardware-related issues on a line card deployed in the field. The test results can be used to verify whether a line card is fault and troubleshoot network issues.

- [Overview of Online Offline Diagnostics, on page 1897](#)
- [How to Configure Online Offline Diagnostics, on page 1898](#)
- [Configuration Example for Online Offline Diagnostics, on page 1899](#)
- [Feature Information for Online Offline Diagnostics, on page 1899](#)

## Overview of Online Offline Diagnostics

The Online Offline Diagnostics is a field diagnostic mechanism that allows the customers to test and verify the line card hardware problems.

To perform a hardware diagnostic test on a line card in the Cisco cBR universal broadband router, download an OOD Field Diagnostic image for free from Cisco.com and use it to verify if the line card problems are due to hardware failure. The customer can run field diagnostic tests on the standby line card at any time without interrupting service. Testing the standby line card improves high availability of the system by ensuring the standby line card is ready for a switchover.

### Field Diagnostic Image Information

Field Diagnostic image is used to run diagnostic tests on a line card and is available from Cisco.com.

First, download it from Cisco.com to one of the flash file systems on the router. Then move it to the line card, and the line card is automatically taken offline. Once field diagnostic tests are complete and the test results are gathered, the Field Diagnostic image must be unloaded from the line card. Normal line card operation will automatically resume after the Field Diagnostic image is unloaded from the line card.

## Benefits of Online Offline Diagnostics

- **Improved Troubleshooting.** Field diagnostics verifies whether a line card problem is hardware-related or not. If the problem is software-related, the Field Diagnostic image allows customer to quickly rule out hardware related cause and focus on fixing the software issue causing the problem.
- **Pre-installation Line Card Hardware Verification.** Field diagnostics verifies whether a line card has hardware problems before installing the line card in a Cisco cBR Series router.

- **Onsite Fault Detection.** Field diagnostics helps to confirm if the problem is hardware-related and if it is necessary to replace the line card.
- **Additional Uptime.** Field diagnostics ensures that line cards are not mistakenly taken offline if the problem is not hardware-related, thereby increasing network uptime.

## Prerequisites for Online Offline Diagnostics

- Before running the OOD Field Diagnostic tests on the working (active) line card in an N + 1 redundancy setup, it is advisable to switch over to the protect (standby) line card before loading the Field Diagnostic image to the line card to avoid service interruption.
- After an OOD Field Diagnostic image is loaded to the line card, the line card goes offline. Therefore, schedule a downtime for the line card to be tested before performing field diagnostic tests.
- Before performing any field diagnostic test, unplug all cables on the device that connect to other interfaces. If the cables that connect interfaces are not unplugged, some field diagnostic tests may send packets to connected devices, which increments packet counters on the receiving interfaces.

## Restrictions for Online Offline Diagnostics

- When accessing a router through Telnet while running an OOD Field Diagnostic test, testing progress messages do not appear on the screen.
- If supervisor switchover occurs during a field diagnostic test, the test stops immediately and the line card run-time image automatically replaces the Field Diagnostic image on the line card.
- This feature is supported on CBR-CCAP-LC-40G line card in Cisco IOS-XE release 3.18.0S and later releases.
- It is suggested to run OOD on one line card at a time to avoid service impact.
- To run OOD on multiple line cards, leave 5 to 10 minutes gap before loading the OOD image to the next line card.

# How to Configure Online Offline Diagnostics

## Configuring Field Diagnostic Test

To load the field diagnostic image and start field diagnostic test, complete the following procedure:

```
copy tftp:image-file {harddisk: | bootflash: | flash:}
request platform hardware diagnostic load slot slot-id image-file autostart
```

## Verifying the Testing Process

To verify whether the field diagnostic tests are running, use the **show platform hardware diagnostic status slot slot-id** command as shown in the example below:

```
Router# show platform hardware diagnostic status slot 0
Online Offline Diagnostic Status (P=Passed, F=Failed, U=Untested)
State          Overall Test Num      Test Done Num      Test Result
-----
Running Auto Test    75                    70                P:69 F:1 U:5
```



**Note** If the test result shows that the failed test number is not 0, please copy the full log and contact Cisco TAC team for support. You can use `dir harddisk:ood/` command to list the log files.

## Removing the Field Diagnostic Image from a Line Card

To unload the Field Diagnostic image, use the `request platform hardware diagnostic unload slot slot-id` command as below:

```
request platform hardware diagnostic unload slot slot-id
```

Then the line card will be reloaded to run-time image.



**Note** To retain the results of a diagnostic test, copy and paste the `show platform hardware diagnostic status slot` command output into a separate file before unloading the Field Diagnostic image. The output of the `show platform hardware diagnostic status slot` command cannot be gathered after unloading the Field Diagnostic image from the line card.

## Configuration Example for Online Offline Diagnostics

The following example shows running output for Online Offline Diagnostics:

```
copy tftp:field_diag harddisk:
request platform hardware diagnostic load slot 0 harddisk:field_diag autostart

Mar 2 16:00:51.933 CST: %IOSXE_OIR-6-REMCARD: Card (cc) removed from slot x
Mar 2 16:00:51.934 CST: %CABLE_CLC-5-LOGGER_LC_REMOVED: Carrier Card x removed
```

## Feature Information for Online Offline Diagnostics

Use Cisco Feature Navigator to find information about the platform support and software image support. Cisco Feature Navigator enables you to determine which software images support a specific software release, feature set, or platform. To access Cisco Feature Navigator, go to the <https://cfng.cisco.com/> link. An account on the Cisco.com page is not required.



**Note** The following table lists the software release in which a given feature is introduced. Unless noted otherwise, subsequent releases of that software release train also support that feature.

*Table 376: Feature Information for Online Offline Diagnostics*

| <b>Feature Name</b>        | <b>Releases</b>             | <b>Feature Information</b>                                                                                       |
|----------------------------|-----------------------------|------------------------------------------------------------------------------------------------------------------|
| Online Offline Diagnostics | Cisco IOS XE Everest 16.6.1 | This feature was integrated into Cisco IOS XE Everest 16.6.1 on theCisco cBR Series Converged Broadband Routers. |





# CHAPTER 119

## Factory Reset

- [Factory Reset, on page 1901](#)

## Factory Reset

This chapter describes the Factory Reset feature and how it can be used to protect or restore a router to an earlier, clean state.

*Table 377: Feature History*

| Feature Name                  | Release Information            | Feature Description                                                                                                                                                                                                                                                                                                                                                          |
|-------------------------------|--------------------------------|------------------------------------------------------------------------------------------------------------------------------------------------------------------------------------------------------------------------------------------------------------------------------------------------------------------------------------------------------------------------------|
| Enhancements to Factory Reset | Cisco IOS XE Dublin 17.12.1    | You can use the <b>factory-reset all secure</b> command to reset the router and securely clear the files that are stored in both bootflash and SSD. This command performs sanitization and clears all the user data from eUSB, SSD, ROMVAR, and ACT2.<br><br>With this release, the <b>factory-reset all secure</b> command is more secure and performs better sanitization. |
| Secure Factory Reset          | Cisco IOS XE Cupertino 17.9.1w | Use the <b>factory-reset all secure</b> command to reset the router and securely clear the files that are stored in both bootflash and SSD. This command performs sanitization and clears all the user data from eUSB, SSD, and ROMVAR and ACT2.                                                                                                                             |

| Feature Name       | Release Information         | Feature Description                                                                                                                                                                                                                                                                                                                                                                                                                                                                                                                                                                                                                                                                |
|--------------------|-----------------------------|------------------------------------------------------------------------------------------------------------------------------------------------------------------------------------------------------------------------------------------------------------------------------------------------------------------------------------------------------------------------------------------------------------------------------------------------------------------------------------------------------------------------------------------------------------------------------------------------------------------------------------------------------------------------------------|
| Fast Factory Reset | Cisco IOS XE Everest 16.6.1 | <p>In this release we introduce the <b>factory-reset all</b> command. The following steps are performed while executing the <b>factory-reset all</b> command:</p> <ol style="list-style-type: none"> <li>1. Backing up of the image.</li> <li>2. Deletion of ROMMON variables.</li> <li>3. Resetting eUSB flash: <ul style="list-style-type: none"> <li>• Overwriting each partition with 0's using the dd command.</li> </ul> </li> <li>4. Resetting SSD: <ul style="list-style-type: none"> <li>• Skipping the dd command to overwrite, and to save time.</li> <li>• Formatting harddisk partition.</li> </ul> </li> <li>5. Copying image and debug log to bootflash.</li> </ol> |

### Information About Factory Reset

Factory Reset is a process of clearing the current running and start-up configuration information and other private user information on a device, and resetting the device to an earlier clean state.

To perform a fast factory reset, use the **factory-reset all** command to erase existing configuration, and other user data and reset the router to a clean state. This command reformats the eUSB Flash, SSD, and clears ROMVAR. The duration of the factory reset process depends on the storage size of the router. It varies from 10–30 minutes.

Starting with Cisco IOS XE Cupertino 17.9.1w, you can use the **factory-reset all secure** command to reset the router and securely clear the files that are stored in both bootflash and SSD. This command performs sanitization and clears all the user data from eUSB, SSD, and ROMVAR and ACT2. Secure reset can take around 1.5 hours for SUP160 and around 2 hours for SUP250.

The Cisco CBR-8 has two Supervisor Modules, 8 Line Cards, 8 Line Card PIC slots, and two Supervisor PIC slots. There are two types of Supervisor Modules, with different SSD locations:

- Cisco cBR-8 Converged Cable Access Router Supervisor 160G (SUP-160)—SSD is present on the Supervisor Module's PIC Card.
- Cisco cBR-8 Converged Cable Access Router Supervisor 250G (SUP-250)—SSD is present on the Supervisor Module.

Only Supervisor Modules store sensitive user information. Factory reset can't be performed when booting with subpackages. To perform factory reset, you must boot with a single consolidated image.

There are several storage components in Cisco cBR-8 Supervisor Modules as listed below:

Table 378: Cisco cBR-8 Supervisor Modules Memory Components

| Memory Component | Type          | Memory Size(GB) | Volatility   | Purpose                                                                                                                                                                                                                  | Data Sanitization                                                                                                                                                                                                                                                                                                                                                              |
|------------------|---------------|-----------------|--------------|--------------------------------------------------------------------------------------------------------------------------------------------------------------------------------------------------------------------------|--------------------------------------------------------------------------------------------------------------------------------------------------------------------------------------------------------------------------------------------------------------------------------------------------------------------------------------------------------------------------------|
| RP memory        | DRAM          | 48GB            | Volatile     | DRAM for CPU                                                                                                                                                                                                             | All data is lost when power is turned off. Sanitization measure is not required.                                                                                                                                                                                                                                                                                               |
| FP memory        | DRAM          | 10GB            | Volatile     | DRAM for data engine (data-plane configuration and packet buffer)                                                                                                                                                        | All data is lost when power is turned off. Sanitization measure is not required.                                                                                                                                                                                                                                                                                               |
| ROM              | SPI ROM Flash | 56MB            | Non-volatile | <ul style="list-style-type: none"> <li>FPGA images</li> <li>BootRom images</li> <li>ROMMON variables</li> </ul>                                                                                                          | Both fast and secure factory reset commands erase ROMMON variables.                                                                                                                                                                                                                                                                                                            |
| TAM              | ACT2          | 10-15KB         | Non-volatile | <ul style="list-style-type: none"> <li>SUDI</li> <li>Keys, including a private configure encryption key.</li> <li>Secure storage</li> </ul>                                                                              | Both fast and secure factory reset commands erase ACT2 user content.                                                                                                                                                                                                                                                                                                           |
| Bootdisk         | eUSB Flash    | 8GB             | Non-volatile | <p>Four types of partitions store:</p> <ul style="list-style-type: none"> <li>Bootflash: images</li> <li>NVRAM and NVRAM backup: IOS CFG</li> <li>OBFL: OBFL logs</li> <li>CSL: Licensing-related information</li> </ul> | <ul style="list-style-type: none"> <li>Fast factory reset reformats bootflash, OBFL, CSL partitions and overwrites NVRAM partitions with zeros.                             <p><b>Note</b> Reformat does not erase file content in the partition.</p> </li> <li>Secure factory reset overwrites the whole device twice with random data then overwrites with zeros.</li> </ul> |

| Memory Component      | Type                    | Memory Size(GB)                                                                                                   | Volatility   | Purpose                                                                                                                                | Data Sanitization                                                                                                                                                                                         |
|-----------------------|-------------------------|-------------------------------------------------------------------------------------------------------------------|--------------|----------------------------------------------------------------------------------------------------------------------------------------|-----------------------------------------------------------------------------------------------------------------------------------------------------------------------------------------------------------|
| SSD Drive             | SATA SSD                | <ul style="list-style-type: none"> <li>• SUP-160 and its PIC: 100GB or 120GB</li> <li>• SUP-250: 240GB</li> </ul> | Non-volatile | One partition mount at /harddisk/ for <ul style="list-style-type: none"> <li>• Images</li> <li>• Core files</li> <li>• Logs</li> </ul> | <ul style="list-style-type: none"> <li>• Fast factory reset reformats harddisk partitions.</li> <li>• Secure factory reset uses a device built-in secure erase command to erase all user data.</li> </ul> |
| Front panel USB Ports | Type-A USB Flash drives |                                                                                                                   | Non-volatile | Used for file transfer                                                                                                                 | Not covered by data sanitization. You can unplug them.                                                                                                                                                    |

### Factory Reset Commands



**Note** Before performing a factory reset:

- Use the **show usb-devices summary** command to view a summary of all the system USB devices (eUSB Flash). See [show usb-devices summary](#).
- Use the **show hdd-devices summary** command to view a summary of all the system HDD/SSD devices. See [show hdd-devices summary](#).

#### factory-reset all

Starting with Cisco IOS XE Cupertino 17.9.1w, the following steps are performed while executing the **factory-reset all** command. See [factory-reset all](#).

1. Backing up of the image.
2. Deleting ROMMON variables and deleting user info in ACT2.
3. Formatting eUSB Flash device partitions.
4. Formatting SSD device partitions.
5. Copying the image and debugging log to bootflash.

#### factory-reset all secure

Starting with Cisco IOS XE Cupertino 17.9.1w, the following steps are performed while executing the **factory-reset all secure** command. See [factory-reset all secure](#).

1. Backing up of the image.
2. Deleting ROMMON variables.
3. Sanitizing eUSB Flash.

- Overwriting the device with random data multiple times and finally fill the device with zeros.
- Verifying that the device has all 0's.
- Recreating partitions.
- Formatting the partitions.

#### 4. Sanitizing SSD

- Sending secure erase command to SSD.
- Verifying that the SSD has all 0's.
- Recreating partitions.
- Formatting a harddisk partition.

#### 5. Copying the image and debugging log to bootflash.

Starting with Cisco IOS XE Cupertino 17.12.1, factory reset is enhanced and is more secure.

#### **Prerequisites for Performing Factory Reset**

- Ensure that all the software images, configurations, and personal data are backed up before performing a factory reset.
- Ensure that there is an uninterruptible power supply when the factory reset is in progress.

#### **Restrictions for Performing a Factory Reset**

- Any software patches that are installed on the router are not restored after the factory reset operation.
- If the factory reset command is issued through a Virtual Teletype (VTY) session, the session is not restored after the completion of the factory reset process.

#### **When to Perform Factory Reset**

- Return Material Authorization (RMA): If a router is returned back to Cisco for RMA, it is important that all sensitive information is removed.
- Router is compromised: If the router data is compromised due to a malicious attack, the router must be reset to factory configuration and then reconfigured once again for further use.
- Repurposing: The router must be moved to a new topology or market from the existing site to a different site.

