



Cisco Converged Broadband Routers Video Configuration Guide for Cisco IOS XE Everest 16.5.1

First Published: 2017-05-07

Americas Headquarters

Cisco Systems, Inc.
170 West Tasman Drive
San Jose, CA 95134-1706
USA
<http://www.cisco.com>
Tel: 408 526-4000
800 553-NETS (6387)
Fax: 408 527-0883



CONTENTS

PART I

Basic Configuration and Provisioning Construct 13

CHAPTER 1

Video Services Provisioning Model 1

Information about Video Services Provisioning 1

Video Provisioning Constructs 1

Feature Information for Video Services Provisioning 2

CHAPTER 2

Video Virtual Carrier Group and Virtual Edge Input 5

Information about Virtual Carrier Group and Virtual Edge Input 5

Virtual Carrier Group 5

Virtual Edge Input 5

How to Configure Virtual Carrier Group and Virtual Edge Input 6

Configuring Virtual Carrier Group 6

Verifying Virtual Carrier Group Configuration 6

Configuring Virtual Edge Input under Logical Edge Device 7

Verifying Virtual Edge Input Configuration 7

Configuration Examples for Virtual Carrier Group and Virtual Edge Input 8

Example: Configuring Virtual Carrier Group 8

Example: Configuring Virtual Edge Input 9

Feature Information for Virtual Carrier Group and Virtual Edge Input 9

CHAPTER 3

Service Distribution Group 11

Information About Service Distribution Group 11

How to Configure the Service Distribution Group 12

Defining the Physical Slot/Bay/Port 12

Configuring QAM Replication 12

- Overriding the Default ONID 13
- Overriding the Default PSI Value 13
- Verifying Service Distribution Group Configuration 13
- Troubleshooting Tips 13
- Configuration Examples 13
 - Configuring a Service Distribution Group 14
- Feature Information for Service Distribution Group 14

CHAPTER 4 Video QAM Carriers 15

- QAM Profile 15
- How to Configure the Video QAM Carriers 15
 - Configuring the Video QAM Profile 15
 - Configuring the Video QAM Carriers 16
 - Verify the configuration of the RF Channel 16
- Configuration Examples 16
 - Video QAM Carriers 17
- Feature Information for QAM Video Carriers 17

CHAPTER 5 Logical Edge Devices 19

- Information about Logical Edge Devices 19
- How to Configure the Logical Edge Devices 19
 - Configuring Session-Based (Dynamic) Logical Edge Devices 19
 - Verifying the Session-Based (Dynamic) Logical Edge Devices Configuration 21
 - Configuring the D6 Discovery Protocol 24
 - Verifying the D6 Configuration 27
- Configuration Examples 27
 - Example: GQI LED Configuration 27
- Feature Information for Logical Edge Devices 28

CHAPTER 6 Cisco Smart Licensing for Video 29

- Video Smart Licensing 29
- Information About Video Smart Licensing 29
 - Benefits of Smart Licensing 29
 - Prerequisites for Video Smart Licensing 29

Restrictions for Video Smart Licensing	30
How to Verify Video Smart Licensing	30
Verifying Video Smart Licensing Using Show Commands	30
Configuration Examples	31
Use Cases or Deployment Scenarios	32
Feature Information for Video Smart Licensing	34

CHAPTER 7**Physical to Virtual Binding 35**

Information About Physical to Virtual Binding	35
How to Configure VPME Encryption	35
Configuring Physical to Virtual Binding	35
Configuring QAM Replication	36
Configuration Examples	36
Example 1: Physical to Virtual Binding Configuration	36
Example 2: Physical to Virtual Binding Configuration	36
Example 3: QAM Replication Configuration	37
Feature Information for Physical to Virtual Binding	37

CHAPTER 8**Table Based Configuration 39**

Information About Table Based Configuration	39
Configuring Table Based Session	39
Configuration Example	40
Virtual Edge Input Bundling	40
Verifying Virtual Edge Input Data	40
Verifying VEI Bundles	41
Configuration Example	41
Feature Information for Table Based Configuration	42

CHAPTER 9**Management IP Interface 43**

Information About Management IP Interface	43
How to Configure the Management IP Interface	43
Configuring the VirtualPortGroup Interface	44
Configuring the Cable Video Management Interface	45
Configuring the LED Management Interface	45

Configuration Examples 46
 Management IP Interface 46
 Feature Information for Management IP Interface 46

CHAPTER 10

Video Encryption 49

Information About Encryption 49
 Prerequisites for Encryption 50
 How to Configure Encryption for the Data Stream 50
 Enforcing Data Stream Encryption Type 50
 Configuring Virtual Carrier Group 50
 Verifying Encryption Configuration 51
 Configuration Examples for Encryption 51
 Example: Enforcing Data Stream Encryption Type 51
 Example: Configuring Virtual Carrier Group 51
 Configuring Privacy Mode Encryption 51
 Configuring VODS-ID 52
 Configuring CEM IP and Port 52
 Configuring Management IP 52
 Verifying PME Connection Status 53
 Verifying PME Version 53
 Verifying PME Sessions on a Line Card 53
 Feature Information for Encryption 54

CHAPTER 11

Global Video Configuration 55

Configuring the Default ONID 55
 Configuring the Default PSI interval 55
 Configuring Video Session Timeouts 56
 Configuration Examples 56
 Example: Global Video Configuration 56
 Feature Information for Global Video Configuration 56

CHAPTER 12

Advanced Video MPEG Features 59

Information about Advanced Video MPEG Features 59
 Reserved Output PID Range 59

	How to Configure Advanced Video MPEG Features	59
	Configuring Reserved Output PID Range	59
	Verifying Reserved Output PID Range Configuration	59
	Configuration Examples for Advanced Video MPEG Features	60
	Example: Configuring Reserved Output PID Range	60
	Feature Information for Advanced Video MPEG Features	60
<hr/>		
CHAPTER 13	Important Notes	61
	Video Packet Routing Requirements	61
<hr/>		
PART II	Cisco cBR Converged Broadband Routers Video Features	63
<hr/>		
CHAPTER 14	PowerKEY VOD	65
	Information About PowerKEY VOD	65
	Overview of PowerKEY VOD	65
	How to Configure PowerKEY VOD	65
	Configuring the Encryption Type on the Line Card	66
	Configuring the Encrypted Virtual Carrier Groups	66
	Configuring the Service Distribution Groups and Binding	67
	Configuring the Logical Edge Device and GQI Protocol	67
	Verifying the PowerKEY VOD Configuration	68
	Troubleshooting Tips	70
	Configuration Examples	71
	Example: Configuring Encryption Type on the Line Card	72
	Example: Configuring Encrypted Virtual Carrier Groups	72
	Example: Configuring Service Distribution Groups and Binding	72
	Feature Information for PowerKEY VOD	72
<hr/>		
CHAPTER 15	Table-Based Video and VPME Encryption	73
	Overview of VPME	73
	Prerequisites for VPME	73
	Restrictions for VPME	74
	How to Configure Table-Based Video Session	74
	Configuring Table-Based Video	74

Configuring Table-Based Session : VEI Input Port-Based	74
Configuring Table-Based Session :VEI Bundle-Based	75
Verifying Table-Based Video Configuration	76
Troubleshooting Video and VPME Encryption	77
Output State is OFF	77
Output Status is Idle or Pending	79
Input State is Active and not Active PSI	80
Abnormalities on the Output	81
Configuring CEM Connectivity for PME Encryption	82
Verifying CEM Connectivity	83
Troubleshooting Tips	83
Connectivity with CEM is Lost	83
How to Configure VPME Encryption	84
Enforcing Data Stream Encryption Type	84
Configuring Virtual Carrier Group	84
Verifying VPME Encryption Configuration	84
Troubleshooting Tips	86
No PMT at the Output	86
Configuration Examples For VPME Encryption	87
Use Cases or Deployment Scenarios	87
Feature Information for Table-Based Video and VPME Encryption	88

CHAPTER 16**PMV Support for Table-Based Videos 89**

Information About the PMV Support for Table-Based Videos	89
Overview of PMV	89
Prerequisites for Configuring PMV	90
Restrictions for Configuring PMV	90
How to Configure PMV	91
Enabling PMV Allocation Scheme for LED	91
Verifying the PMV Configuration on LED	91
How to Configure Sessions with PMV Value	92
Verifying the PMV on RF Channel Sessions	93
Troubleshooting Tips	93
Disabling PMV Allocation Scheme for LED	93

Verifying the Disabled PMV Configuration	93
Configuration Examples	94
Feature Information for PMV Support	97

CHAPTER 17
Video QAM Replication 99

QAM Replication	99
Information About Replication	99
Overview of QAM Replication	99
Benefits of QAM Replication	100
Prerequisites for Replication	100
Restrictions for QAM Replication	101
Configuring Replication for Table-Based or Session-Based Video	101
Verifying Replication of Table Based Video Sessions	101
Configuration Examples	102
Feature Information for Replication	103

CHAPTER 18
D6 Discovery Protocol 105

Information About D6 Discovery Protocol	105
Overview of the D6 Discovery Protocol	105
Prerequisites for D6 Discovery Protocol	106
How to Configure the D6 Discovery Protocol	107
Configuring the Mandatory D6 Discovery Protocol Parameters	107
Verifying the D6 Discovery Protocol Configurations	108
Troubleshooting the D6 Mandatory Parameters Configuration	109
Configuring the D6 Discovery Protocol Optional Parameters	110
Verifying the Hold Time and Timeout Settings	111
Troubleshooting the D6 Optional Parameters Configuration	111
Example: D6 Discovery Protocol Configuration	111
Deployment Scenario for the D6 Discovery Protocol	112
Feature Information for D6 Discovery Protocol	113

CHAPTER 19
Switched Digital Video 115

Switched Digital Video Services	115
Session Cloning	115

Redundant Multicast Sources	115
Benefits of Switched Digital Video	116
Prerequisites for Switched Digital Video	117
Restrictions for Switched Digital Video	117
Information About Switched Digital Video	117
QAM Sharing	117
QAM Replication	117
MPTS Pass-through Session	117
How to Configure the Switched Digital Video Services	118
Configuring Multicast Routing	118
Configuring Multicast Label	119
Configuring Multicast Table-based Sessions	119
Configuring Source Switching	120
Verifying Switched Digital Video Configuration	120
Troubleshooting Switched Digital Video Configuration	121
Configuration Examples for Switched Digital Video	122
Feature Information for Switched Digital Video	125

CHAPTER 20**DVB Video on Demand 127**

Information About DVB VOD	127
Overview of DVB VOD	127
Session based Scrambling Setup	127
Fail-to-Clear	128
Tier based Scrambling Setup	128
Restrictions for DVB	129
How to Configure DVB	129
Configuring DVB	129
Verifying the DVB Configuration	131
Troubleshooting Tips	132
Configuration Examples	133
Example 1: Basic Session-based Scrambling Configuration	133
Example 2: Basic Tier-based Scrambling Configuration	134
Additional References	135
Feature Information for DVB Video on Demand	136

CHAPTER 21**DualCrypt Encryption Mode Support 137**

- Hardware Compatibility Matrix for Cisco cBR Series Routers 137
- Information about DualCrypt Encryption Mode 138
 - Prerequisites for Dualcrypt Encryption Mode 138
 - Restrictions for DualCrypt Encryption Mode 140
- How to Configure Dualcrypt Encryption Mode 140
 - Configuring DVB Session for DualCrypt Encryption 140
 - Verifying DVB Session for DualCrypt Encryption 140
 - Verifying the GQI Configuration 141
 - Verifying the GQI Sessions for Encryption 142
 - Verifying ONID and TSID of the QAMs Configured for Specific LED 143
 - Troubleshooting Tips 144
- Configuration Examples 144
 - Example: Basic Session-based Scrambling Configuration 145
 - Example: Session-based Configuration with EIS Binding to LED using LED ID 145
 - Example: Configuration with EIS Binding to LED using LED Name 146
 - Example: EIS Binding to IP Address Other than Default DVB Management IP Address 146
 - Example: Session-based Configuration with VRF 147
- Feature Information for DualCrypt Encryption Mode 148

CHAPTER 22**Low Latency VOD Support 149**

- Information About Low Latency VOD Support 149
 - Overview of Low Latency VOD Support 149
- How to Configure Low Latency VOD Support 150
 - Configuring the Low Latency Virtual Carrier Group 150
 - Verifying the Low Latency Virtual Carrier Group Configuration 150
 - Verifying the Low Latency in Linecard 150
 - Configuring the Jitter Buffer Size for Table Based Session 151
 - Configuring the Jitter Buffer Size for GQI 151
 - Verifying Jitter Buffer Size for GQI 151
 - Verifying the Low Latency Sessions 152
- Feature Information for Low Latency VOD Support 153

CHAPTER 23

Video MIBs 155

SCTE-HMS-MPEG-MIB 155

SCTE-HMS-QAM-MIB 156



PART I

Basic Configuration and Provisioning Construct

- [Video Services Provisioning Model](#), on page 1
- [Video Virtual Carrier Group and Virtual Edge Input](#), on page 5
- [Service Distribution Group](#), on page 11
- [Video QAM Carriers](#), on page 15
- [Logical Edge Devices](#), on page 19
- [Cisco Smart Licensing for Video](#), on page 29
- [Physical to Virtual Binding](#), on page 35
- **Table Based Configuration**, on page 39
- [Management IP Interface](#), on page 43
- [Video Encryption](#), on page 49
- [Global Video Configuration](#), on page 55
- [Advanced Video MPEG Features](#), on page 59
- [Important Notes](#), on page 61



CHAPTER 1

Video Services Provisioning Model

The Cisco cBR-8 router offers the next generation CCAP platform supporting converged CMTS and EQAM functionality. The redesigned video data model supports the creation of virtual edge devices within the platform. This data model simplifies the provisioning procedure and enables seamless migration to virtualized video service management in the future.

The video provisioning constructs of the new data model provide hardware abstraction and divides services into virtual edge devices for easier provisioning at scale. It also provides isolation between the service applications at the software layer. A bind-operation connects these constructs to the physical resources.

- [Information about Video Services Provisioning](#) , on page 1
- [Feature Information for Video Services Provisioning](#), on page 2

Information about Video Services Provisioning

Video Provisioning Constructs

The Video Services Provisioning Model has the following elements:

- **Logical Edge Device (LED)**—a virtual edge device in the Cisco cBR-8 chassis that can be provisioned for static or dynamic sessions.
- **Virtual Carrier Group (VCG)**—a collection of Virtual QAM Carriers (RF channels) provisioned on an LED.
- **Virtual Edge Input (VEI)**—assigned either globally to all VCGs in the LED or optionally assigned uniquely to an individual VCG.
- **Service Distribution Group (SDG)**—a collection of one or more RF ports that define the physical slot/bay/port to be used in a video service.

Connection of Virtual and Physical Constructs

The VCGs are bound to an SDG using a bind command (bind-vcg). This connects the virtual carriers to the physical ports listed in the SDG. After binding, a path from the VEI is mapped to the RF ports.

The image below shows the elements in the Video Provisioning Construct.

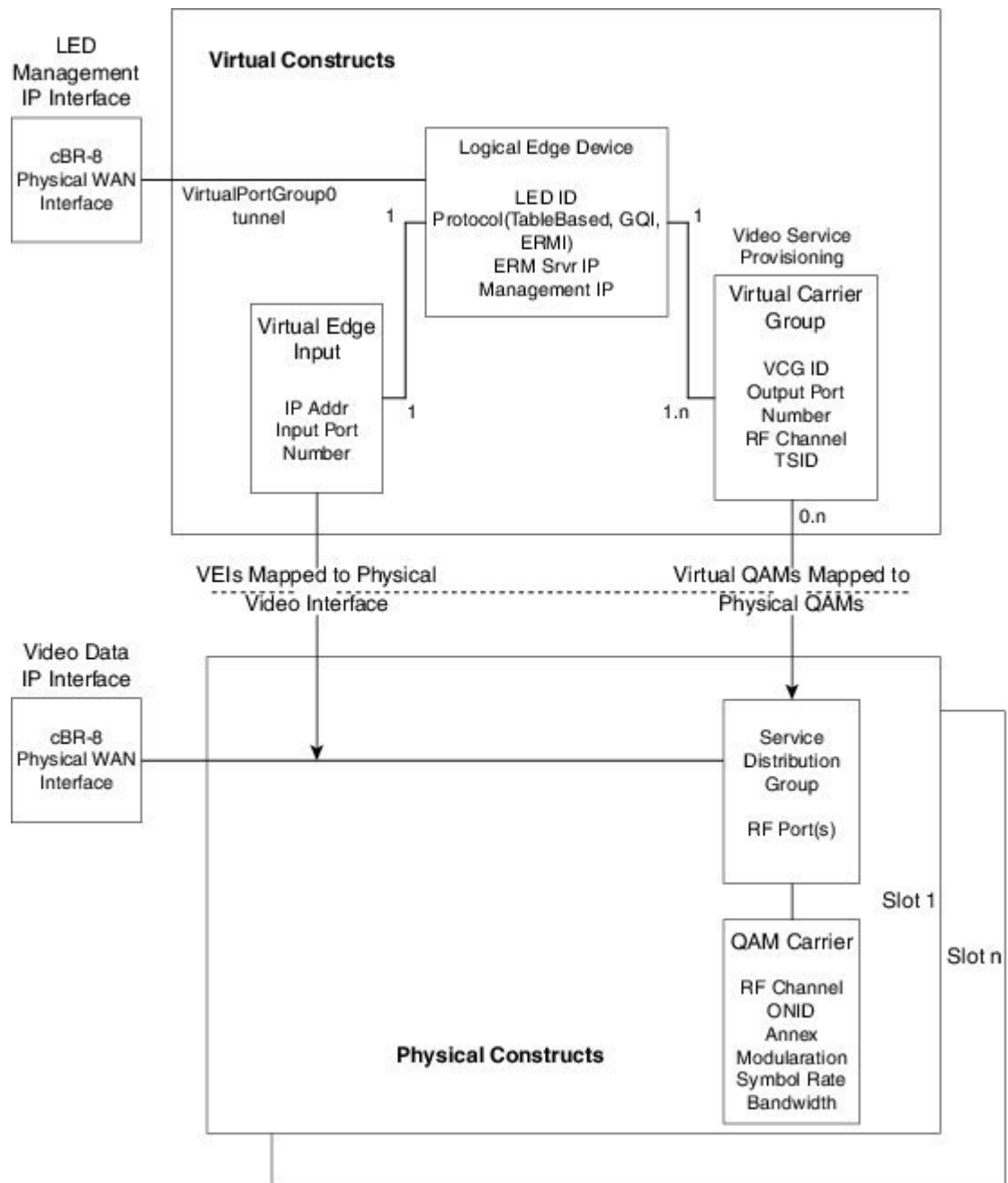

Feature Information for Video Services Provisioning

Use Cisco Feature Navigator to find information about the platform support and software image support. Cisco Feature Navigator enables you to determine which software images support a specific software release, feature set, or platform. To access Cisco Feature Navigator, go to the www.cisco.com/go/cfn link. An account on the Cisco.com page is not required.



Note The following table lists the software release in which a given feature is introduced. Unless noted otherwise, subsequent releases of that software release train also support that feature.

Table 1: Feature Information for Video Services Provisioning

Feature Name	Releases	Feature Information
Video Services Provisioning	Cisco IOS XE Everest 16.6.1	This feature was integrated on the Cisco cBR Series Converged Broadband Routers.



CHAPTER 2

Video Virtual Carrier Group and Virtual Edge Input

A Virtual Carrier Group (VCG) is a collection of virtual QAM carriers (RF channels) provisioned on a Logical Edge Device (LED). A Virtual Edge Input (VEI) is a customer assigned IP address that is used, from the Head End, as a destination IP address for unicast video IP packets.

- [Information about Virtual Carrier Group and Virtual Edge Input, on page 5](#)
- [How to Configure Virtual Carrier Group and Virtual Edge Input, on page 6](#)
- [Configuration Examples for Virtual Carrier Group and Virtual Edge Input, on page 8](#)
- [Feature Information for Virtual Carrier Group and Virtual Edge Input, on page 9](#)

Information about Virtual Carrier Group and Virtual Edge Input

Virtual Carrier Group

A Virtual Carrier Group (VCG) is a collection of virtual QAM carriers (RF channels) provisioned on a Logical Edge Device (LED).

Each VCG must have a unique name and ID, since it also assigns attributes such as TSID and output port number to the virtual QAM carriers. The output port number only needs to be unique per LED. However, TSID/ONID pair must be unique for the chassis.

The service type must be designated in each VCG and the encrypt command must be entered if the carriers are to be encrypted. Enabling the VCG to use encryption and service type designates that each QAM carrier listed in the VCG will consume a QAM encryption license and video service type license. The actual number of licenses consumed will be done at VCG binding operation and is also dependent on the QAM replication requirements.

For more information on how the licenses are consumed, see [Cisco Smart Licensing for Video](#).

Virtual Edge Input

A Virtual Edge Input (VEI) is a customer assigned IP address that is used, from the Head End, as a destination IP address for unicast video IP packets. Each VEI will need to be configured with a routable IP address from within the customer's network.

A VEI is assigned within a Logical Edge Device. Each Virtual Carrier Group (VCG) is associated with one or more IP addresses that represent VEIs.

For GQI protocol, VEI must be configured under the LED, since GQI expects VEI to be able to reach any Virtual QAM carrier listed in the same LED. Again, for GQI protocol, there is a limit of five VEIs per LED.

For the table based protocol, VEI may be configured under the LED or under a VCG. If the VEI is configured under a VCG, it can only reach the virtual QAM carriers associated with that particular VCG.

During the VCG binding operation, each VEI IP address will be bound to a single Video IP interface.

You can isolate the video traffic from other network traffic using MPLS (Multiprotocol Label Switching) and VRF (Virtual Routing and Forwarding), by configuring the VRF name parameter in video-edge-input command.



Note Do not use the same VEI IP address in multiple VRFs, as Head End video session management servers are not MPLS or VRF aware.

How to Configure Virtual Carrier Group and Virtual Edge Input

Configuring Virtual Carrier Group

Before you begin

Since each VEI needs to be configured with a routable IP address from within the customer's network, choose the IP addresses to use prior to configuring the VEIs.

Error messages for problems with the VCG configuration will become evident during the bind operation. Errors include overlapping rf-channels.

In virtual-edge-input-ip command line configuration, vrf is an optional parameter and can be used for MPLS routing or to make VEI private from other parts of the network.

To configure virtual carrier group, follow the steps below:

```
enable
configure terminal
cable video
virtual-carrier-group name [id number]
virtual-edge-input-ip ip-address [vrf vrf-name] input-port-number port-number
encrypt
service-type narrowcast
rf-channel start_channel-end_channel tsid start_tsid-end_tsid output-port-number
start_number-end_number
```

Verifying Virtual Carrier Group Configuration

To verify the virtual carrier group configuration, use the **show cable video virtual-carrier-group** command as shown in the example below.

```
Router# show cable video virtual-carrier-group all
Number of Virtual Carrier Groups: 1
ID      Name      Input      Service-Distribution-Group  Logical-Edge-Device  Total
```

	IP Address	Name	Name	RF-Channel	
1	vcg-0	-	vcg	vcgcast	5

Configuring Virtual Edge Input under Logical Edge Device

Before you begin

Since each VEI will need to be configured with a routable IP address from within the customer's network, choose the IP addresses to use prior to configuring the VEIs.

To configure virtual edge input, follow the steps below:

```
enable
configure terminal
cable video
virtual-carrier-group name [id] number
virtual-edge-input-ip ip-address [vrf vrf-name] input-port-number port-number
vcg vcg-name
active
```

To configure virtual edge input under logical edge device, follow the steps below:

```
enable
configure terminal
cable video
logical-edge-device name [id] number
protocol table-based
virtual-edge-input-ip ip-address [vrf vrf-name] input-port-number port-number
vcg vcg-name
active
```

Verifying Virtual Edge Input Configuration

To verify the virtual edge input configuration, use the **show cable video logical-edge-device** command as shown in the example below.

```
Router# show cable video logical-edge-device id 1
Logical Edge Device: led
Id: 1
Protocol: GQI
Service State: Active
Discovery State: Disable
Management IP: 1.33.2.10
MAC Address: c414.3c17.6000
Number of Servers: 2
  Server 1: 1.200.1.193
  Server 2: 1.200.1.183
Reset Interval: 5
Keepalive Interval: 5
Retry Count:3
Number of Virtual Carrier Groups: 2
Number of Share Virtual Edge Input: 1
Number of Physical Qams: 94
Number of Sessions: 240
No Reserve PID Range
```

Virtual Edge Input:

Input Port ID	VEI IP	Slot/Bay	Bundle ID	Gateway IP
1	174.102.1.1	7/0	-	-

Virtual Carrier Group:

ID	Name	Total VEI	Total RF-channel	Service-Distribution-Group Name	Service-Distribution-Groupup ID
1	vcg	0	28	sdg	1
2	vcg-2	0	19	sdg	1

Integrated Cable	Physical QAM ID	Admin State	Operational State	TSID	ONID	Output Port	VCG ID	SDG ID	Encryption Capable
7/0/0:1	1	ON	UP	29	1000	30	2	1	powerkey
7/0/0:2	2	ON	UP	30	1000	30	2	1	powerkey
7/0/0:3	3	ON	UP	31	1000	30	2	1	powerkey
7/0/0:4	4	ON	UP	32	1000	30	2	1	powerkey
7/0/0:5	5	ON	UP	33	1000	30	2	1	powerkey
7/0/0:6	6	ON	UP	34	1000	30	2	1	powerkey
7/0/0:7	7	ON	UP	35	1000	30	2	1	powerkey
7/0/0:8	8	ON	UP	36	1000	30	2	1	powerkey
7/0/0:9	9	ON	UP	37	1000	30	2	1	powerkey

To verify the VEI configuration with MPLS-VPN VRF, use the **show ip arp vrf** command as shown in the example below:

```
Router# show ip arp vrf Video-VOD-Vrf
Protocol Address Age (min) Hardware Addr Type Interface
Internet 174.102.1.1 - 12ab.0007.ce01 ARPA Video7/0/0
```

Configuration Examples for Virtual Carrier Group and Virtual Edge Input

This section provides configuration examples for the Virtual Carrier Group and Virtual Edge Input:

Example: Configuring Virtual Carrier Group

The following example shows how to configure virtual carrier group:

```
enable
configure terminal
cable video
virtual-carrier-group vcg-0 id 1
virtual-edge-input-ip 174.101.1.1 input-port-number 1
virtual-edge-input-ip 174.102.1.1 vrf Video-VOD-Vrf input-port-number 2
encrypt
service-type narrowcast
rf-channel 0-10 tsid 1-11 output-port-number 1-11
```

Example: Configuring Virtual Edge Input

The following example shows how to configure virtual edge input:

```
enable
configure terminal
cable video
logical-edge-device led_bcl id 1
protocol table-based
virtual-edge-input-ip 174.102.1.1 input-port-number 1
vcg vcg_bcl
active
```

You can also configure VEI to be associated with a MPLS-VPN VRF:

```
enable
configure terminal
cable video
virtual-carrier-group vcg1 id 1
virtual-edge-input-ip 174.102.1.1 vrf Video-VOD-Vrf input-port-number 1
vcg vcg-name
active
```

Under logical edge device, follow the steps below:

```
enable
configure terminal
cable video
logical-edge-device led_bcl id 1
protocol table-based
virtual-edge-input-ip 174.102.1.1 vrf Video-VOD-Vrf input-port-number 1
vcg vcg_bcl
active
```

Feature Information for Virtual Carrier Group and Virtual Edge Input

Use Cisco Feature Navigator to find information about the platform support and software image support. Cisco Feature Navigator enables you to determine which software images support a specific software release, feature set, or platform. To access Cisco Feature Navigator, go to the www.cisco.com/go/cfn link. An account on the Cisco.com page is not required.



Note The following table lists the software release in which a given feature is introduced. Unless noted otherwise, subsequent releases of that software release train also support that feature.

Table 2: Feature Information for Virtual Carrier Group and Virtual Edge Input

Feature Name	Releases	Feature Information
Virtual Carrier Group and Virtual Edge Input	Cisco IOS XE Everest 16.5.1 Cisco IOS XE Everest 16.6.1	This feature was integrated on the Cisco cBR Series Converged Broadband Routers.
Using VRF for Video Session Traffic	Cisco IOS XE Everest 16.5.1 Cisco IOS XE Everest 16.6.1	This feature was integrated on the Cisco cBR Series Converged Broadband Routers.



CHAPTER 3

Service Distribution Group

The Service Distribution Group (SDG) is a collection of one or more RF ports and defines the physical slot/bay/port to be used in a video service.

Contents

- [Information About Service Distribution Group, on page 11](#)
- [How to Configure the Service Distribution Group, on page 12](#)
- [Verifying Service Distribution Group Configuration, on page 13](#)
- [Troubleshooting Tips, on page 13](#)
- [Configuration Examples, on page 13](#)
- [Feature Information for Service Distribution Group, on page 14](#)

Information About Service Distribution Group

The following are the required components for configuring an SDG:

- **Multiple Ports**—Multiple ports in an SDG replicate all QAMs from the Virtual Carrier Group (VCG) to every port.
- **Unicast**—Unicast (VoD) services cannot be replicated across line cards.
- **TSID**—The TSIDs should always be unique (North American MSO). Non-unique TSIDs can be used if the ONID is changed from the default value of zero (0).

The convention slot/bay/port represents the following:

- **Slot**—Slot is the line card slot number. Slot can be configured 0–3 or 6–9. Slots 4 and 5 are the supervisor slots.
- **Bay**—Bay is the Cisco cBR-8 chassis number. This parameter is always configured as 0.
- **Port**—Port is the RF port number. This parameter can be configured 1–8.

**Note**

- For a Remote PHY line card, the SDG does not describe a collection of RF ports. SDG specifies the line card, bay, and downstream cable controller where the video will be destined. Use **rpdc downstream-cable slot/bay/controller** command instead of **rf-port integrated-cable slot/bay/port** command. Only one downstream cable controller can be specified for an SDG, so QAM replication is not supported. (However, the controller can be multicast to multiple remote PHY devices which is similar to QAM replication but occurs external to the cBR-8.)
- Cisco Remote PHY Device 1x2 can join up to 30 multicast streams simultaneously for video.
- Cisco HA Shelf can join up to 30 multicast streams simultaneously per RPD for video.

How to Configure the Service Distribution Group

This section describes how to configure SDGs for the video session on Cisco cBR-8.

Defining the Physical Slot/Bay/Port

To define the Service Distribution Group (SDG), you must define the physical *slot/bay/port* to be used in a video service.

Before You Begin

Make sure that the controller type is **video** for the *slot/bay/port* that you use for the SDG. Errors due to the incorrect controller type used in the SDG appear during the bind operation.

To define the physical *slot/bay/port*, complete the following procedure:

```
configure terminal
cable video
service-distribution-group sdg name
rf-port integrated-cable slot/bay/port
```

Configuring QAM Replication

To configure QAM replication for service group size alignment between the DOCSIS and video services to one or more ports, you can add more ports into the service distribution group configuration.

Before You Begin

Make sure that the controller type is **video** for the *slot/bay/port* that you would use for the SDG. For more information, see the **Video QAM Carriers** section. Errors due to the incorrect controller type used in the SDG appear during the bind operation.

To configure QAM replication, complete the following procedure:

```
configure terminal
cable video
service-distribution-group service distribution group name
rf-port integrated-cable slot/bay/port
rf-port integrated-cable slot/bay/port
```

Overriding the Default ONID

You can override the default ONID, by defining a new ONID value in the SDG configuration. If you perform this configuration, all channels associated with the configured SDG will have the new ONID value. By default, the system ONID is 0, which is commonly used in North America.

To override the default ONID, complete the following procedure:

```
configure terminal
cable video
service-distribution-group service distribution group name
onid onid number
```

Overriding the Default PSI Value

To override the default PSI value, complete the following procedure:

```
configure terminal
cable video
service-distribution-group service distribution group name
psi-interval psi-interval msec
```

Verifying Service Distribution Group Configuration

To verify the SDG configuration, use the **show cable video service-distribution-group** command as shown in the example below:

```
show cable video service-distribution-group all
Number of Service Distribution Groups: 1
ID Name      Virtual-Carrier-Group  Logical-Edge-Device  RF-Port  ONID  PSI Interval
-----
          Name              Name
-----
1 vod        vod                    LED        7/0/0    0     100
1 vod        vod                    LED        7/0/1    0     100
1 vod        vod                    LED        7/0/2    0     100
1 vod        vod                    LED        7/0/3    0     100
1 vod        vod                    LED        7/0/4    0     100
1 vod        vod                    LED        7/0/5    0     100
1 vod        vod                    LED        7/0/6    0     100
1 vod        vod                    LED        7/0/7    0     100
```

Troubleshooting Tips

To undo any configuration, use the **no** form of the command. This command is useful if you have configured something by mistake. The errors are not apparent until you perform the bind operation.

Configuration Examples

This section provides example configurations for the service distribution group.

Configuring a Service Distribution Group

```

configure terminal
cable video
service-distribution-group vod id 1
  onid 100
  rf-port integrated-cable 7/0/0
  rf-port integrated-cable 7/0/1
  rf-port integrated-cable 7/0/2
  rf-port integrated-cable 7/0/3

```

Feature Information for Service Distribution Group

Use Cisco Feature Navigator to find information about the platform support and software image support. Cisco Feature Navigator enables you to determine which software images support a specific software release, feature set, or platform. To access Cisco Feature Navigator, go to the www.cisco.com/go/cfn link. An account on the Cisco.com page is not required.



Note The following table lists the software release in which a given feature is introduced. Unless noted otherwise, subsequent releases of that software release train also support that feature.

Table 3: Feature Information for Service Distribution Group

Feature Name	Releases	Feature Information
Service Distribution Group	Cisco IOS XE Everest 16.5.1 Cisco IOS XE Everest 16.6.1	This feature was integrated on the Cisco cBR Series Converged Broadband Routers.



CHAPTER 4

Video QAM Carriers

This document describes how to configure the video QAM carriers on the Cisco cBR Series Converged Broadband Router.

Contents

- [QAM Profile, on page 15](#)
- [How to Configure the Video QAM Carriers, on page 15](#)
- [Configuration Examples, on page 16](#)
- [Feature Information for QAM Video Carriers, on page 17](#)

QAM Profile

A QAM profile describes the common downstream channel modulator settings, referred to as physical layer parameters. This includes QAM constellation, symbol rate, interleaver-depth, spectrum-inversion, and annex.

For more information about the downstream interface configuration, see [Downstream Interface Configuration](#).

But be aware that, if you configure annex A 6MHz or 7MHz in a QAM profile, then this QAM profile cannot be applied to a DOCSIS channel.

How to Configure the Video QAM Carriers

Configuring the Video QAM Profile

To configure the video QAM profile, complete the following procedure:

```
configure terminal
cable downstream qam-profile id
annex {A freq_spacing|B|C}
modulation value
interleaver-depth value
symbol-rate value
spectrum-inversion {on|off}
description line
```

The frequency spacing of 6MHz, 7MHz and 8 MHz can be selected or annex A. In this case, the QAM profile can only be applied to a video channel.

Spectral inversion happens as a result of mixing processes in RF or IF electronics. Spectrum inversion allows for the adaptation of older equipment with the new plant. The mixing of I and Q are used to create a quadrant profile. For some settops, the inversion of the quadrant profile is needed where the axis are flipped such that I represents the X and Q represents the Y-axis. Most modern equipment can detect and resolve the inversion split.

Configuring the Video QAM Carriers

To configure the Video QAM carriers, complete the following procedure:

```
configure terminal
controller integrated-cable slot/bay/port
rf-channel start-channel - end-channel
type video
start-frequency frequency
rf-output normal
power-adjust number
qam-profile qam-profile number
```



Note For video provisioning, the carriers must be of type “video” in the controller integrated-cable configuration.

Verify the configuration of the RF Channel

To verify the RF channel configuration, use the Show controller integrated-cable rf-chan command as shown in the example below:

```
Router#show controllers integrated-Cable 9/0/7 rf-channel 0-10
Load for five secs: 6%/0%; one minute: 5%; five minutes: 5%
Chan State Admin Frequency Type Annex Mod srate Interleaver dcid power output
0 UP UP 100000000 VIDEO A 256 5361 I12-J17 - 34.0 NORMAL
1 UP UP 106000000 VIDEO A 256 5361 I12-J17 - 34.0 NORMAL
2 UP UP 112000000 VIDEO A 256 5361 I12-J17 - 34.0 NORMAL
3 UP UP 118000000 VIDEO A 256 5361 I12-J17 - 34.0 NORMAL
4 UP UP 124000000 VIDEO A 256 5361 I12-J17 - 34.0 NORMAL
5 UP UP 130000000 VIDEO A 256 5361 I12-J17 - 34.0 NORMAL
6 UP UP 136000000 VIDEO A 256 5361 I12-J17 - 34.0 NORMAL
7 UP UP 142000000 VIDEO A 256 5361 I12-J17 - 34.0 NORMAL
8 UP UP 148000000 VIDEO A 256 5361 I12-J17 - 34.0 NORMAL
9 UP UP 154000000 VIDEO A 256 5361 I12-J17 - 34.0 NORMAL
10 UP UP 160000000 VIDEO A 256 5361 I12-J17 - 34.0 NORMAL
```

Configuration Examples

This section provides configuration examples for the QAM video carrier.

Video QAM Carriers

The following is a sample for the Video QAM carrier configuration:

```
Router#enable
Router(config)#cable downstream qam-profile 4
Router(config-qam-prof)#annex A 6MHz
Router(config-qam-prof)#modulation 256
Router(config-qam-prof)#interleaver-depth I32-J4
Router(config-qam-prof)#symbol-rate 5361
Router(config-qam-prof)#spectrum-inversion off
Router(config-qam-prof)#description default-annex-a-256-qam
Router(config-qam-prof)#exit
Router(config)#controller Integrated-Cable 3/0/0
Router(config-controller)#max-carrier 128
Router(config-controller)#base-channel-power 34
Router(config-controller)#freq-profile 0
Router(config-controller)#rf-chan 0 95
Router(config-rf-chan)#type video
Router(config-rf-chan)#frequency 93000000
Router(config-rf-chan)#rf-output NORMAL
Router(config-rf-chan)#power-adjust 0
Router(config-rf-chan)#docsis-channel-id 1
Router(config-rf-chan)#qam-profile 1
```

Feature Information for QAM Video Carriers

Use Cisco Feature Navigator to find information about the platform support and software image support. Cisco Feature Navigator enables you to determine which software images support a specific software release, feature set, or platform. To access Cisco Feature Navigator, go to the www.cisco.com/go/cfn link. An account on the Cisco.com page is not required.



Note The following table lists the software release in which a given feature is introduced. Unless noted otherwise, subsequent releases of that software release train also support that feature.

Table 4: Feature Information for QAM Video Carriers

Feature Name	Releases	Feature Information
QAM Video Carriers	Cisco IOS XE Everest 16.5.1	This feature was integrated on the Cisco cBR Series Converged Broadband Routers.
Annex A Variable Channel Width	Cisco IOS XE Everest 16.5.1	This feature was integrated on the Cisco cBR Series Converged Broadband Routers.



CHAPTER 5

Logical Edge Devices

A Logical Edge Device (LED) is a virtual edge device within the cBR-8 and can be provisioned for static or dynamic sessions.

Contents

- [Information about Logical Edge Devices, on page 19](#)
- [How to Configure the Logical Edge Devices, on page 19](#)
- [Configuration Examples, on page 27](#)
- [Feature Information for Logical Edge Devices, on page 28](#)

Information about Logical Edge Devices

An LED interfaces remotely to a head end video Session Resource Manager (SRM) using the GQI protocol. It also represents a group of locally managed table-based video sessions.

In Cisco cBR-8, you can create up to 32 LEDs to simultaneously manage the video QAM carriers. Each LED manages a set of virtual QAM carriers independently. Due to the limitation of the GQI protocol, a GQI LED can only manage a set of QAM carriers in a single line card, unlike the table-based LED, which can manage more than a single line card.

In addition, an LED can be optionally configured to support the D6 discovery protocol to report a QAM resource to the SRM.

How to Configure the Logical Edge Devices

This section describes how to configure LEDs for the video session on Cisco cBR-8.

Configuring Session-Based (Dynamic) Logical Edge Devices

GQI is a protocol for the GQI LED to interface with the remote SRM.

For system using discovery protocol, the D6 discovery protocol should be enabled to report the QAM resources of the LED to the remote SRM.

An active flag should be enabled on the LED to indicate that it is active. This flag indicates that the connectivity with the SRM can be setup and the LED can start handling GQI message exchange from the SRM.

You cannot edit or remove the LED data when it is in the active mode. To do so, you must first move the LED to inactive mode and then disconnect it from the SRM.

Due to the limitations of the GQI protocol, GQI LED cannot have Virtual Carrier Groups that span across multiple cable line cards (CLC).



Note In Cisco IOS-XE Release 16.5.1, only GQI version 2 is supported for all GQI LEDs.

Before You Begin

The following data is necessary to define a GQI LED:

- The Management IP address that the SRM uses to setup connectivity with the LED. The IP address must be in the same subnet as configured in the VirtualPortGroup.
- A unique MAC address per LED. Using the chassis MAC address as a basis, increment the least significant number to give a unique identifier (MAC address) for each LED. This number should be unique with respect to the GQI server and does not really relate to a true MAC address. Thus, the number is irrelevant, but needs to be unique.



Tip Use the **show diag all eeprom detail | include MAC** command to get the chassis MAC address.

- The primary and secondary IP addresses of the remote SRM.
- Virtual Carrier Group (VCG). For more information, see Video Virtual Carrier Group and Virtual Edge Input.
- Connection-orientated controls such as, keep alive, reset interval, and timeout value.
- Virtual Edge Input (VEI) configured with a routable IP address from within the network. For more information, see Video Virtual Carrier Group and Virtual Edge Input.

To configure the session-based LEDs, complete the following procedure:

```
configure terminal
cable video
logical-edge-device name [id number]
protocol gqi
mgmt-ip ip address
server ip address
virtual-edge-input ip address input-port-number port number
vcg vcg name
vcg vcg name
mac-address mac address
keepalive retry retry count interval seconds
reset interval seconds
active
```

Verifying the Session-Based (Dynamic) Logical Edge Devices Configuration

To verify a GQI LED configuration, use the **show cable video logical-edge-device** command as shown in the example below:

```
show cable video logical-edge-device id 1
```

```
Logical Edge Device: led
Id: 1
Protocol: GQI
Service State: Active
Discovery State: Disable
Management IP: 1.33.2.10
MAC Address: c414.3c17.6000
Number of Servers: 2
  Server 1: 1.200.1.193
  Server 2: 1.200.1.183
Reset Interval: 5
Keepalive Interval: 5   Retry Count:3
Number of Virtual Carrier Groups: 2
Number of Share Virtual Edge Input: 1
Number of Physical Qams: 94
Number of Sessions: 240
No Reserve PID Range
```

```
Virtual Edge Input:
```

Input Port ID	VEI IP	Slot/Bay	Bundle ID	Gateway IP
1	174.102.1.1	7/0	-	-

```
Virtual Carrier Group:
```

ID	Name	Total VEI	Total RF-channel	Service-Distribution-Group Name
1	vcg	0	28	sdg
2	vcg-2	0	19	sdg

Integrated VCG Cable ID	Physical SDG QAM ID	Admin Encryption State Capable	Operational State	TSID	ONID	Output Port
7/0/0:20 1	20 1	ON powerkey	UP	1	1000	1
7/0/0:21 1	21 1	ON powerkey	UP	2	1000	2
7/0/0:22 1	22 1	ON powerkey	UP	3	1000	3
7/0/0:23 1	23 1	ON powerkey	UP	4	1000	4
7/0/0:24 1	24 1	ON powerkey	UP	5	1000	5
7/0/0:25 1	25 1	ON powerkey	UP	6	1000	6
7/0/0:26 1	26 1	ON powerkey	UP	7	1000	7
7/0/0:27 1	27 1	ON powerkey	UP	8	1000	8
7/0/0:28 1	28 1	ON powerkey	UP	9	1000	9

Verifying the Session-Based (Dynamic) Logical Edge Devices Configuration

7/0/0:29	29	ON	UP	10	1000	10
1	1	powerkey				
7/0/0:30	30	ON	UP	11	1000	11
1	1	powerkey				
7/0/0:31	31	ON	UP	12	1000	12
1	1	powerkey				
7/0/0:32	32	ON	UP	13	1000	13
1	1	powerkey				
7/0/0:33	33	ON	UP	14	1000	14
1	1	powerkey				
7/0/0:34	34	ON	UP	15	1000	15
1	1	powerkey				
7/0/0:35	35	ON	UP	16	1000	16
1	1	powerkey				
7/0/0:36	36	ON	UP	17	1000	17
1	1	powerkey				
7/0/0:37	37	ON	UP	18	1000	18
1	1	powerkey				
7/0/0:38	38	ON	UP	19	1000	19
1	1	powerkey				
7/0/0:39	39	ON	UP	20	1000	20
1	1	powerkey				
7/0/0:40	40	ON	UP	21	1000	21
1	1	powerkey				
7/0/0:41	41	ON	UP	22	1000	22
1	1	powerkey				
7/0/0:42	42	ON	UP	23	1000	23
1	1	powerkey				
7/0/0:43	43	ON	UP	24	1000	24
1	1	powerkey				
7/0/0:44	44	ON	UP	25	1000	25
1	1	powerkey				
7/0/0:45	45	ON	UP	26	1000	26
1	1	powerkey				
7/0/0:46	46	ON	UP	27	1000	27
1	1	powerkey				
7/0/0:47	47	ON	UP	28	1000	28
1	1	powerkey				
7/0/7:20	20	ON	UP	1	1000	1
1	1	powerkey				
7/0/7:21	21	ON	UP	2	1000	2
1	1	powerkey				
7/0/7:22	22	ON	UP	3	1000	3
1	1	powerkey				
7/0/7:23	23	ON	UP	4	1000	4
1	1	powerkey				
7/0/7:24	24	ON	UP	5	1000	5
1	1	powerkey				
7/0/7:25	25	ON	UP	6	1000	6
1	1	powerkey				
7/0/7:26	26	ON	UP	7	1000	7
1	1	powerkey				
7/0/7:27	27	ON	UP	8	1000	8
1	1	powerkey				
7/0/7:28	28	ON	UP	9	1000	9
1	1	powerkey				
7/0/7:29	29	ON	UP	10	1000	10
1	1	powerkey				
7/0/7:30	30	ON	UP	11	1000	11
1	1	powerkey				
7/0/7:31	31	ON	UP	12	1000	12
1	1	powerkey				
7/0/7:32	32	ON	UP	13	1000	13
1	1	powerkey				

7/0/7:33	33	ON	UP	14	1000	14
1	1	powerkey				
7/0/7:34	34	ON	UP	15	1000	15
1	1	powerkey				
7/0/7:35	35	ON	UP	16	1000	16
1	1	powerkey				
7/0/7:36	36	ON	UP	17	1000	17
1	1	powerkey				
7/0/7:37	37	ON	UP	18	1000	18
1	1	powerkey				
7/0/7:38	38	ON	UP	19	1000	19
1	1	powerkey				
7/0/7:39	39	ON	UP	20	1000	20
1	1	powerkey				
7/0/7:40	40	ON	UP	21	1000	21
1	1	powerkey				
7/0/7:41	41	ON	UP	22	1000	22
1	1	powerkey				
7/0/7:42	42	ON	UP	23	1000	23
1	1	powerkey				
7/0/7:43	43	ON	UP	24	1000	24
1	1	powerkey				
7/0/7:44	44	ON	UP	25	1000	25
1	1	powerkey				
7/0/7:45	45	ON	UP	26	1000	26
1	1	powerkey				
7/0/7:46	46	ON	UP	27	1000	27
1	1	powerkey				
7/0/7:47	47	ON	UP	28	1000	28
1	1	powerkey				
7/0/0:1	1	ON	UP	29	1000	29
2	1	powerkey				
7/0/0:2	2	ON	UP	30	1000	30
2	1	powerkey				
7/0/0:3	3	ON	UP	31	1000	31
2	1	powerkey				
7/0/0:4	4	ON	UP	32	1000	32
2	1	powerkey				
7/0/0:5	5	ON	UP	33	1000	33
2	1	powerkey				
7/0/0:6	6	ON	UP	34	1000	34
2	1	powerkey				
7/0/0:7	7	ON	UP	35	1000	35
2	1	powerkey				
7/0/0:8	8	ON	UP	36	1000	36
2	1	powerkey				
7/0/0:9	9	ON	UP	37	1000	37
2	1	powerkey				
7/0/0:10	10	ON	UP	38	1000	38
2	1	powerkey				
7/0/0:11	11	ON	UP	39	1000	39
2	1	powerkey				
7/0/0:12	12	ON	UP	40	1000	40
2	1	powerkey				
7/0/0:13	13	ON	UP	41	1000	41
2	1	powerkey				
7/0/0:14	14	ON	UP	42	1000	42
2	1	powerkey				
7/0/0:15	15	ON	UP	43	1000	43
2	1	powerkey				
7/0/0:16	16	ON	UP	44	1000	44
2	1	powerkey				
7/0/0:17	17	ON	UP	45	1000	45
2	1	powerkey				

7/0/0:18	18	ON	UP	46	1000	46
2	1	powerkey				
7/0/0:19	19	ON	UP	47	1000	47
2	1	powerkey				
7/0/7:1	1	ON	UP	29	1000	29
2	1	powerkey				
7/0/7:2	2	ON	UP	30	1000	30
2	1	powerkey				
7/0/7:3	3	ON	UP	31	1000	31
2	1	powerkey				
7/0/7:4	4	ON	UP	32	1000	32
2	1	powerkey				
7/0/7:5	5	ON	UP	33	1000	33
2	1	powerkey				
7/0/7:6	6	ON	UP	34	1000	34
2	1	powerkey				
7/0/7:7	7	ON	UP	35	1000	35
2	1	powerkey				
7/0/7:8	8	ON	UP	36	1000	36
2	1	powerkey				
7/0/7:9	9	ON	UP	37	1000	37
2	1	powerkey				
7/0/7:10	10	ON	UP	38	1000	38
2	1	powerkey				
7/0/7:11	11	ON	UP	39	1000	39
2	1	powerkey				
7/0/7:12	12	ON	UP	40	1000	40
2	1	powerkey				
7/0/7:13	13	ON	UP	41	1000	41
2	1	powerkey				
7/0/7:14	14	ON	UP	42	1000	42
2	1	powerkey				
7/0/7:15	15	ON	UP	43	1000	43
2	1	powerkey				
7/0/7:16	16	ON	UP	44	1000	44
2	1	powerkey				
7/0/7:17	17	ON	UP	45	1000	45
2	1	powerkey				
7/0/7:18	18	ON	UP	46	1000	46
2	1	powerkey				
7/0/7:19	19	ON	UP	47	1000	47
2	1	powerkey				

•

Configuring the D6 Discovery Protocol

D6 discovery protocol is the discovery portion of the Comcast Next Generation on Demand (NGOD) specification. D6 discovery protocol sends out carrier information such as frequency, annex, modulation mode, interleave, and edge input information such as IP address and maximum bandwidth to an Edge Resource Manager (ERM). D6 discovery protocol also sends unique structured names (topological location information) for each edge input or carrier output. From these structured names, and input and RF port numbers, the ERM can infer the topological network location of both the QAM streaming input port (IP) and RF output port (MPEG).

The D6 discovery protocol configuration can be performed only when the LED protocol is either table-based or GQI. The LED must be in inactive mode to edit or create a D6 discovery protocol configuration. The D6 discovery protocol configuration parameters are:

- Management IP—The source IP address used to establish a connection with the external D6 discovery protocol server (ERM). The IP address must be in the same subnet as configured in a virtual port group.

For GQI LED, this configuration is not needed under D6 discovery protocol as it is automatically fetched from the LED configuration.

- D6 discovery protocol server IP address and port—Identifies the remote D6 discovery protocol server (ERM) IP address and listening port used by the D6 discovery protocol client in LED to setup a connection with the peer. You can configure only one server address and port per LED.
- FQDN (Fully Qualified Domain Name)—This can be given instead of IP address for D6 discovery protocol server.
- Streaming zone—Streaming zone as configured in the D6 discovery protocol server (ERM). The name should match with the configured D6 discovery protocol server in the ERM for the connection to be established.
- Component name—The name of the Edge QAM device. Each LED is considered by the D6 discovery protocol server as a separate Edge QAM component. This name is used by the D6 discovery protocol server to represent the LED.
- Timeout value—(Optional) Time to wait for connection in socket call.
- Hold time value—(Optional) Time interval that decides the interval of the keepalive message exchange between the client and the server.
- Input group—(Optional) Each virtual edge input IP address under the LED can be assigned an input group name and the maximum bandwidth that is used to send traffic to it. This information is used in D6 discovery protocol messages when advertising the edge inputs to the D6 discovery protocol server. If these parameters are not configured then for group name, the LED or the VCG name, and the default bandwidth of 20 Gbps are used. You must repeat this command for each VEI and VCG under the LED. For GQI LED, there is no option to set VEI IP under the VCG, so, this input group CLI is not available for the VCGs for GQI LEDs.

To configure the D6 discovery protocol, complete the following procedure:

```
configure terminal
```

```
cable video
```

```
logical-edge-device
```

```
device name [id  
number]
```

```
protocol
```

```
gqi | table-based
```

```
mgmt-ip
```

```
ip address
```

```
server
```

```
ip address
```

```
virtual-edge-input
```

```
ip address  
input-port-number  
port number  
  
vcg  
vcg name  
  
vcg  
vcg name  
  
mac-address  
mac address  
  
keepalive retry  
retry count  
interval  
seconds  
  
reset interval  
seconds  
  
discovery d6  
  
streaming-zone  
name  
  
component-name  
name  
  
d6-server  
ip address [port]  
  
d6-server fqdn  
domain-name  
  
timeout  
seconds  
  
holdtime  
seconds  
  
input-group led vei-ip  
led vei ip address  
group-name  
group name [bandwidth  
mbps]  
  
exit
```

active

Verifying the D6 Configuration

To verify the D6 discovery protocol configuration, use the **show cable video logical-edge-device** command as shown in the example below.

This CLI command shows the status and statistics of the D6 client associated to the LED. In the example below, it shows the duration and number of open, updated, keepalive and notification messages exchanged between the D6 client and the server in that duration. It also indicates how many unknown or unrecognized messages are received from the server. When the open message count is more than 1, it indicates that the connection is terminated and reconnected.

```
show cable video logical-edge-device id 1 d6
```

```
Logical Edge Device: led1
Id: 1
D6 Summary:
-----
Enabled           : Yes
VREP Version      : 2
D6 State          : Established
Management IP     : 1.21.2.11
Source Port       : 6069
D6 Server IP      : 172.25.20.144
D6 Server Port    : 6069
Hold Time(negotiated): 30
Timeout           : 90
Keep Alive Interval : 10
Streaming Zone    : Sanjose.ciscolab
failure Reason    : No Failure
-----

D6 Statistics:
-----
Duration  Dir   Open   Update   KeepAlive  Notification  Unknown
-----
1         RX    1      0         9           0             0
1         TX    1      13        11          0             0
-----
```

Configuration Examples

This section provides configuration examples for the LED configuration.

Example: GQI LED Configuration

Example: Example: GQI LED Configuration

```
cable video
  mgmt-intf VirtualPortGroup 0
  encryption
    linecard 7/0 ca-system powerkey scrambler des
  service-distribution-group sdg id 1
  onid 1000
```

```

rf-port integrated-cable 7/0/0
rf-port integrated-cable 7/0/7
virtual-carrier-group vcg id 1
  encrypt
  rf-channel 20-47 tsid 1-28 output-port-number 1-28
virtual-carrier-group vcg-2 id 2
  encrypt
  rf-channel 1-19 tsid 29-47 output-port-number 29-47
bind-vcg
  vcg vcg sdg sdg
  vcg vcg-2 sdg sdg
logical-edge-device led id 1
  protocol gqi
  mgmt-ip 1.33.2.10
  mac-address c414.3c17.6000
  server 1.200.1.193
  server 1.200.1.183
  virtual-edge-input-ip 174.102.1.1 input-port-number 1
  vcg vcg
  vcg vcg-2
  active

```

Feature Information for Logical Edge Devices

The following table provides release information about the feature or features described in this module. This table lists only the software release that introduced support for a given feature in a given software release train. Unless noted otherwise, subsequent releases of that software release train also support that feature.

Use Cisco Feature Navigator to find information about platform support and Cisco software image support. To access Cisco Feature Navigator, go to www.cisco.com/go/cfn. An account on Cisco.com is not required.

Table 5: Feature Information for Logical Edge Devices

Feature Name	Releases	Feature Information
Logical Edge Devices	Cisco IOS XE Everest 16.5.1 Cisco IOS XE Everest 16.6.1	This feature was integrated on the Cisco cBR Series Converged Broadband Routers.



CHAPTER 6

Cisco Smart Licensing for Video

The Cisco Smart Licensing for Video on the Cisco cBR router leverages existing Cisco cBR Smart Licensing framework that includes Call Home and SLA capabilities.

- [Video Smart Licensing](#) , on page 29
- [Information About Video Smart Licensing](#), on page 29
- [How to Verify Video Smart Licensing](#), on page 30
- [Configuration Examples](#), on page 31
- [Use Cases or Deployment Scenarios](#), on page 32
- [Feature Information for Video Smart Licensing](#), on page 34

Video Smart Licensing

The Cisco Smart Licensing feature uses a pooled license model. All FRUs in the chassis and multiple such chassis share the entitlements for Upstream (US), Downstream (DS), WAN, Narrowcast (NC), Broadcast (BC), encrypted licenses (PME, PKY, DVB), and Replicate (RPL) as long as they do not exceed the entitlement count for that pool.

For information on entitlement usage, see the [Cisco Smart Licensing](#).

Information About Video Smart Licensing

Benefits of Smart Licensing

Cisco Smart Licensing is intended to overcome the limitations and issues of the enforced licensing method. For more information, see the [Cisco Smart Licensing](#) document .

Prerequisites for Video Smart Licensing

See the [Cisco Smart Licensing](#) document.

Restrictions for Video Smart Licensing

For video services, the VCG service type determines the number of licenses consumed for bound VCGs. The QAM channel **shut/no shut** state has no relevance for video (unlike DOCSIS services). When the service type is not defined, the NC license entitlements are consumed per QAM channel.

How to Verify Video Smart Licensing

Verifying Video Smart Licensing Using Show Commands

Use the **show cable license** command to verify video smart licensing configuration.

To verify all license information, use the **show cable license all** command:

```
Router# show cable license all

-----
Entitlement:  Downstream License
Consumed count: 768
Consumed count reported to SmartAgent: 0 Forced-Shut count: 0 Enforced state: No Enforcement

-----
Entitlement:  Upstream License
Consumed count: 64
Consumed count reported to SmartAgent: 64 Forced-Shut count: 0 Enforced state: No Enforcement

-----
Entitlement:  WAN License
Consumed count: 2
Consumed count reported to SmartAgent: 2 Forced-Shut count: 0 Enforced state: No Enforcement

-----
Entitlement:  LCHA License
Consumed count: 0
Consumed count reported to SmartAgent: 0 Forced-Shut count: 0 Enforced state: No Enforcement

-----
Entitlement:  Video Narrowcast License
Consumed count: 0
Consumed count reported to SmartAgent: 0 Forced-Shut count: 0 Enforced state: No Enforcement

-----
Entitlement:  Video Narrowcast Replicate License Consumed count: 0 Consumed count reported
to SmartAgent: 0 Forced-Shut count: 0 Enforced state: No Enforcement

-----
Entitlement:  Video Narrowcast PKEY License Consumed count: 0 Consumed count reported to
SmartAgent: 0 Forced-Shut count: 0 Enforced state: No Enforcement

-----
Entitlement:  Video Narrowcast PME License Consumed count: 0 Consumed count reported to
SmartAgent: 0 Forced-Shut count: 0 Enforced state: No Enforcement

-----
Entitlement:  Video Narrowcast DVB License Consumed count: 0 Consumed count reported to
SmartAgent: 0 Forced-Shut count: 0 Enforced state: No Enforcement
```

To view specific video license configuration, use the appropriate keyword with the **show cable license** command:

```
Router# show cable license ?
  all      Show all license information
  ds       DOCSIS downstreams
  lcha     LCHA groups
  nc       Narrowcast video
  nc_dvb   Narrowcast video DVB
  nc_pky   Narrowcast video PowerKEY
  nc_pme   Narrowcast video PME
  nc_rpl   Narrowcast video replicate
  us       DOCSIS upstreams
  wan      WAN ports
```

For example, to verify Narrowcast video configuration, use the **show cable license nc** command:

```
Router # show cable license nc
-----
Entitlement:  Video Narrowcast License
Consumed count: 128
Consumed count reported to SmartAgent: 128 Forced-Shut count: 0 Enforced state: No Enforcement
```

Configuration Examples

Example 1: Show Running Output for Basic Configuration

```
cable video
service-distribution-group sdg-lic id 64
  rf-port integrated-cable 7/0/0
service-distribution-group sdg-lic1 id 63
  rf-port integrated-cable 7/0/1
virtual-carrier-group vcg-lic1 id 158
  rf-channel 0 tsid 65535 output-port-number 1
virtual-carrier-group vcg-lic2 id 157
  rf-channel 1-3 tsid 65532-65534 output-port-number 2-4
virtual-carrier-group vcg-lic3 id 156
  rf-channel 4-7 tsid 65528-65531 output-port-number 5-8
virtual-carrier-group vcg-lic4 id 155
  rf-channel 8-15 tsid 65520-65527 output-port-number 9-16
virtual-carrier-group vcg-lic5 id 154
  rf-channel 16-31 tsid 65504-65519 output-port-number 17-32
virtual-carrier-group vcg-lic6 id 153
  rf-channel 32-63 tsid 65472-65503 output-port-number 33-64
virtual-carrier-group vcg-lic7 id 152
  rf-channel 64-127 tsid 65408-65471 output-port-number 65-128
virtual-carrier-group vcg-lic8 id 151
  rf-channel 0-127 tsid 65280-65407 output-port-number 129-256
bind-vcg
vcg vcg-lic1 sdg sdg-lic
vcg vcg-lic2 sdg sdg-lic
vcg vcg-lic3 sdg sdg-lic
vcg vcg-lic4 sdg sdg-lic
vcg vcg-lic5 sdg sdg-lic
vcg vcg-lic6 sdg sdg-lic
```

```

vcg vcg-lic7 sdg sdg-lic
vcg vcg-lic8 sdg sdg-lic1
exit

```

Example 2: Show Running Output for QRG and NC License Configuration

```

cable video
service-distribution-group sdg-lic id 64
  rf-port integrated-cable 7/0/0
  rf-port integrated-cable 7/0/2
service-distribution-group sdg-lic1 id 63
  rf-port integrated-cable 7/0/1
  rf-port integrated-cable 7/0/3
  rf-port integrated-cable 7/0/4
  rf-port integrated-cable 7/0/5
  rf-port integrated-cable 7/0/6
  rf-port integrated-cable 7/0/7
virtual-carrier-group vcg-lic1 id 158
  rf-channel 0-55 tsid 65480-65535 output-port-number 1-56
virtual-carrier-group vcg-lic2 id 157
  rf-channel 0-55 tsid 65424-65479 output-port-number 57-112
bind-vcg
  vcg vcg-lic1 sdg sdg-lic
  vcg vcg-lic2 sdg sdg-lic1
exit

```

Use Cases or Deployment Scenarios

Case 1: Narrowcast Video Services with PowerKEY Encryption

```

cable video
encrypt
linecard 7/0 ca-system powerkey scrambler des
service-distribution-group sdg-lic id 64
  rf-port integrated-cable 7/0/0
  rf-port integrated-cable 7/0/2
  rf-port integrated-cable 7/0/3
service-distribution-group sdg-lic1 id 63
  rf-port integrated-cable 7/0/1
  rf-port integrated-cable 7/0/4
  rf-port integrated-cable 7/0/5
  rf-port integrated-cable 7/0/6
  rf-port integrated-cable 7/0/7
virtual-carrier-group vcg-lic1 id 158
encrypt
  rf-channel 0 tsid 65535 output-port-number 1
virtual-carrier-group vcg-lic2 id 157
  rf-channel 1-3 tsid 65532-65534 output-port-number 2-4
virtual-carrier-group vcg-lic3 id 156
encrypt
  rf-channel 4-7 tsid 65528-65531 output-port-number 5-8
virtual-carrier-group vcg-lic4 id 155
  rf-channel 8-15 tsid 65520-65527 output-port-number 9-16
virtual-carrier-group vcg-lic5 id 154
encrypt
  rf-channel 16-31 tsid 65504-65519 output-port-number 17-32

```

```

virtual-carrier-group vcg-lic6 id 153
  rf-channel 32-63 tsid 65472-65503 output-port-number 33-64
virtual-carrier-group vcg-lic7 id 152
encrypt
  rf-channel 64-127 tsid 65408-65471 output-port-number 65-128
virtual-carrier-group vcg-lic8 id 151
encrypt
  rf-channel 0-127 tsid 65280-65407 output-port-number 129-256
bind-vcg
vcg vcg-lic1 sdg sdg-lic
vcg vcg-lic2 sdg sdg-lic
vcg vcg-lic3 sdg sdg-lic
vcg vcg-lic4 sdg sdg-lic
vcg vcg-lic5 sdg sdg-lic
vcg vcg-lic6 sdg sdg-lic
vcg vcg-lic7 sdg sdg-lic
vcg vcg-lic8 sdg sdg-lic1
exit

```

Case 2: Narrowcast Video Services with PME Encryption

```

cable video
encrypt
linecard 7/0 ca-system pme scrambler dvs042
service-distribution-group sdg-lic id 64
  rf-port integrated-cable 7/0/0
  rf-port integrated-cable 7/0/2
  rf-port integrated-cable 7/0/3
service-distribution-group sdg-lic1 id 63
  rf-port integrated-cable 7/0/1
  rf-port integrated-cable 7/0/4
  rf-port integrated-cable 7/0/5
  rf-port integrated-cable 7/0/6
  rf-port integrated-cable 7/0/7
virtual-carrier-group vcg-lic1 id 158
  rf-channel 0 tsid 65535 output-port-number 1
virtual-carrier-group vcg-lic2 id 157
encrypt
  rf-channel 1-3 tsid 65532-65534 output-port-number 2-4
virtual-carrier-group vcg-lic3 id 156
  rf-channel 4-7 tsid 65528-65531 output-port-number 5-8
virtual-carrier-group vcg-lic4 id 155
encrypt
  rf-channel 8-15 tsid 65520-65527 output-port-number 9-16
virtual-carrier-group vcg-lic5 id 154
  rf-channel 16-31 tsid 65504-65519 output-port-number 17-32
virtual-carrier-group vcg-lic6 id 153
encrypt
  rf-channel 32-63 tsid 65472-65503 output-port-number 33-64
virtual-carrier-group vcg-lic7 id 152
  rf-channel 64-127 tsid 65408-65471 output-port-number 65-128
virtual-carrier-group vcg-lic8 id 151
encrypt
  rf-channel 0-127 tsid 65280-65407 output-port-number 129-256
bind-vcg
vcg vcg-lic1 sdg sdg-lic
vcg vcg-lic2 sdg sdg-lic
vcg vcg-lic3 sdg sdg-lic
vcg vcg-lic4 sdg sdg-lic
vcg vcg-lic5 sdg sdg-lic
vcg vcg-lic6 sdg sdg-lic
vcg vcg-lic7 sdg sdg-lic

```

```

vcg vcg-lic8 sdg sdg-lic1
exit

```

Feature Information for Video Smart Licensing

Use Cisco Feature Navigator to find information about the platform support and software image support. Cisco Feature Navigator enables you to determine which software images support a specific software release, feature set, or platform. To access Cisco Feature Navigator, go to the www.cisco.com/go/cfn link. An account on the Cisco.com page is not required.



Note The following table lists the software release in which a given feature is introduced. Unless noted otherwise, subsequent releases of that software release train also support that feature.

Table 6: Feature Information for Video Smart Licensing

Feature Name	Releases	Feature Information
Video Smart Licensing	Cisco IOS XE Everest 16.5.1 Cisco IOS XE Everest 16.6.1	This feature was integrated on the Cisco cBR Series Converged Broadband Routers.



CHAPTER 7

Physical to Virtual Binding

The Virtual Carrier Group (VCG) is bound to a Service Distribution Group (SDG) using a bind command (`bind-vcg`). This connects the virtual carriers to the physical ports listed in the SDG. After binding, a path from the Virtual Edge Input (VEI) is mapped to the RF ports.

- [Information About Physical to Virtual Binding, on page 35](#)
- [How to Configure VPME Encryption, on page 35](#)
- [Configuration Examples, on page 36](#)
- [Feature Information for Physical to Virtual Binding, on page 37](#)

Information About Physical to Virtual Binding

In general, more than one VCG can be bound to the same SDG, only if the RF-channels in the VCG are not overlapping each other. However, one VCG cannot be bound to multiple SDGs.

If you want to configure one VCG to multiple SDGs, you should configure QAM replication instead. For more information, see [Configuring QAM Replication](#) section.

How to Configure VPME Encryption

This section describes how to configure physical to virtual binding and QAM replication on Cisco cBR-8.

- [Configuring Physical to Virtual Binding, on page 35](#)
- [Configuring QAM Replication, on page 36](#)

Configuring Physical to Virtual Binding

To bind a set of virtual RF-channels defined in the VCG to the physical port in the SDG, perform the following:

```
enable
configure terminal
cable video
bind-vcg
vcg vcg-name sdg sdg-name
exit
```

Configuring QAM Replication

To configure QAM replication to one or more ports, add the ports to an SDG configuration as following:

```
enable
configure terminal
cable video
service-distribution-group name
rf-port integrated-cable slot/bay/port
rf-port integrated-cable slot/bay/port
exit
```

Configuration Examples

This section provides configuration examples for the physical to virtual binding configuration.

Example 1: Physical to Virtual Binding Configuration

The following is a sample in which the port 7/0/2 of SDG *west-region* binds with 0 to 10 RF-channels of VCG *movie-channels* to physically identify the 7/0/2:0 to 7/0/2:10 QAM carriers.

Example 1 :

```
Router#config t
Router(config)#cable video
Router(config-video)#service-distribution-group west-region
Router(config-video-sdg)#rf-port integrated-cable 7/0/2
Router(config-video-sdg)#exit
Router(config-video)#virtual-carrier-group movie-channels
Router(config-video-vcg)#rf-channel 0-10 tsid 1-11 output-port-num 1-11
Router(config-video-vcg)#exit
Router(config-video)#bind-vcg
Router(config-video-bd)# vcg movie-channels sdg west-regions
```

Example 2: Physical to Virtual Binding Configuration

The following is a sample in which the *movie-channels* VCG and *news-channels* VCG bind with *west-regions* SDG.

Example 2 :

```
Router#config t
Router(config)#cable video
Router(config-video)#service-distribution-group west-region
Router(config-video-sdg)#rf-port integrated-cable 7/0/2
Router(config-video-sdg)#exit
Router(config-video)#virtual-carrier-group movie-channels
Router(config-video-vcg)#rf-channel 0-10 tsid 1-11 output-port-num 1-11
Router(config-video-vcg)#exit
Router(config-video)#virtual-carrier-group news-channels
Router(config-video-vcg)#rf-channel 11-15 tsid 12-16 output-port-num 12-16
Router(config-video-vcg)#exit
Router(config-video)#bind-vcg
Router(config-video-bd)# vcg movie-channels sdg west-regions
Router(config-video-bd)# vcg news-channels sdg west-regions
```

Example 3: QAM Replication Configuration

The following is a sample in which video replication is set across 7/0/0 and 7/0/1 ports:

Example 3 :

```
Router#config t
Router(config)#cable video
Router(config-video)# service-distribution-group qrg-example
Router(config-video-sdg)# rf-port integrated-cable 7/0/0
Router(config-video-sdg)# rf-port integrated-cable 7/0/1
```

Feature Information for Physical to Virtual Binding

Use Cisco Feature Navigator to find information about the platform support and software image support. Cisco Feature Navigator enables you to determine which software images support a specific software release, feature set, or platform. To access Cisco Feature Navigator, go to the www.cisco.com/go/cfn link. An account on the Cisco.com page is not required.



Note The following table lists the software release in which a given feature is introduced. Unless noted otherwise, subsequent releases of that software release train also support that feature.

Table 7: Feature Information for Physical to Virtual Binding

Feature Name	Releases	Feature Information
Physical to Virtual Binding	Cisco IOS XE Everest 16.5.1 Cisco IOS XE Everest 16.6.1	This feature was integrated on the Cisco cBR Series Converged Broadband Routers.



CHAPTER 8

Table Based Configuration

The table-based video is a local session management that provisions using CLI. The statically allocated local video sessions can be either unicast or multicast video stream.

- [Information About Table Based Configuration, on page 39](#)
- [Configuring Table Based Session, on page 39](#)
- [Virtual Edge Input Bundling, on page 40](#)
- [Feature Information for Table Based Configuration, on page 42](#)

Information About Table Based Configuration

Table-based video session configuration can be performed for a range or an individual session under each Quadrature Amplitude Modulation (QAM) carrier that is being assigned to a table-based Logical Edge Device (LED). In cBR-8, you can create multiple LEDs for table-based video sessions; each LED manages one set of QAM carriers for table-based sessions. Table-based sessions can be configured as a pass-through, remap, or a data piping session.

Configuring Table Based Session

To configure the encryption type for a VOD session, perform the following steps:

```
enable
configure terminal
cable video
table-based
vcg vcg-name
rf-channel n-m
session sess-name input-port id start-udp-port udp port number
num-sessions-per-qam 1-80 processing-type remap start-program n jitter
10-200 msec [cbr | vbr]
exit
```

Configuration Example

The following is a sample in which two sessions are created per RF channel, HBO-1 and HBO-2 are for channel 0, HBO-3 and HBO-4 are for channel 1. The destination IP address is obtained from VCG (if any), otherwise from the LED broadcast.

```
Router(config)#cable video
Router(config-video)#table-based
Router(config-video-tb)#vcg bcast
Router(config-video-tb-vcg)#rf-channel 0-1
Router(config-video-tb-vcg-sess)# session HBO input-port 10 start-udp-port 1
num-sessions-per-qam 2 processing-type remap start-program 1 jitter 100 cbr
Router(config-video-tb-vcg-sess)# session HBO bundle-id 1 start-udp-port 49152
num-sessions-per-qam 2 processing-type program start-program 1 jitter 100 cbr
```

Virtual Edge Input Bundling

Virtual Edge Input Bundling assists with load balancing from the Head End. This allows multiple VEIs to be accessed via a gateway, since it is unknown at the time of configuration which VEI the stream will come in on. Thus, when the Head End sends a stream to the gateway, it enters the cBR-8 in on any VEI in the bundle. VEI bundling can be performed only if table based protocol is used for a particular LED.

To bundle the VEIs, perform the following steps:

Before You Begin

- All video sessions must have unique UDP ports for the Head End.
- Create two or more Virtual Edge Inputs using the following command:

```
virtual-edge-input-ip ipaddr vrf vrfname input-port-number #
```



Note Same IP address cannot be used in more than one bundle.

```
enable
configure terminal
cable video
logical-edge-device
protocol table-based
vei-bundle id input-port-number #
exit
```

Verifying Virtual Edge Input Data

To verify the VEI data, use the following command:

```
Router# show cable video logical-edge-device [all | id | name]
```

Example:

```
Router# show cable video logical-edge-device id 1
Logical Edge Device: led-vei
Id: 1
Protocol: Table-based
Service State: Active
```

```

Discovery State: Disable
Number of Virtual Carrier Groups: 1
Number of Share Virtual Edge Input: 5
Number of Physical Qams: 5
Number of Sessions: 0
No Reserve PID Range

```

Virtual Edge Input:

Input Port ID	VEI IP	Slot/Bay	Bundle ID	Gateway IP
11	11.11.11.11	7/0	-	-
22	22.22.22.22	7/0	-	-
66	66.66.66.66	7/0	40000	177.0.10.3
77	77.77.77.77	7/0	40000	177.0.10.3
222	222.222.222.222	7/0	40000	177.0.10.3

Virtual Carrier Group:

ID	Name	Total VEI	Total RF-channel	Service-Distribution-Group Name	Service-Distribution-Group ID
1	vcg-vei	5	5	sdg-vei	1

Integrated Cable	Physical QAM ID	Admin State	Operational State	TSID	ONID	Output Port	VCG ID	SDG ID	Encryption Capable
7/0/3:0	208	ON	UP	0	0	1	1	1	clear
7/0/3:1	209	ON	UP	1	0	2	1	1	clear
7/0/3:2	210	ON	UP	2	0	3	1	1	clear
7/0/3:3	211	ON	UP	3	0	4	1	1	clear
7/0/3:4	212	ON	UP	4	0	5	1	1	clear

Verifying VEI Bundles

To view the VEI bundles, use the following command:

```
Router# show cable video vei-bundle all
```

Example:

This is a sample output of the show command that displays the VEI bundle details.

```
Router# show cable video vei-bundle all
```

```
Total VEI Bundles: 1
```

Bundle ID	LED ID	Input Port ID	VEI IP	Slot/Bay	Gateway IP
40000	1	33	33.33.33.33	7/0	177.0.10.3
40000	1	44	44.44.44.44	7/0	177.0.10.3
40000	1	66	66.66.66.66	7/0	177.0.10.3
40000	1	77	77.77.77.77	7/0	177.0.10.3
40000	1	222	222.222.222.222	7/0	177.0.10.3

Configuration Example

The following is a sample in which five VEIs are created on VCG and bundled:

```

cable video
  service-distribution-group sdg-vei id 1

```

```

rf-port integrated-cable 7/0/3
virtual-carrier-group vcg-vei id 1
  virtual-edge-input-ip 111.111.111.111 input-port-number 111
  virtual-edge-input-ip 222.222.222.222 input-port-number 222
  virtual-edge-input-ip 33.33.33.33 input-port-number 33
  virtual-edge-input-ip 44.44.44.44 input-port-number 44
  virtual-edge-input-ip 55.55.55.55 vrf Video-VOD-Vrf input-port-number 55
  rf-channel 0-4 tsid 0-4 output-port-number 1-5
virtual-carrier-group vcg-veil id 2
  virtual-edge-input-ip 111.111.111.111 input-port-number 111
  virtual-edge-input-ip 222.222.222.222 input-port-number 222
  virtual-edge-input-ip 33.33.33.33 input-port-number 33
  virtual-edge-input-ip 44.44.44.44 input-port-number 44
  rf-channel 5-10 tsid 5-10 output-port-number 5-10
bind-vcg
  vcg vcg-vei sdg sdg-vei
  vcg vcg-veilsdg sdg-vei
logical-edge-device led-vei id 1
  protocol table-based
  virtual-edge-input-ip 11.11.11.11 input-port-number 11
  virtual-edge-input-ip 22.22.22.22 input-port-number 22
  virtual-edge-input-ip 66.66.66.66 input-port-number 66
  virtual-edge-input-ip 77.77.77.77 input-port-number 77
  virtual-edge-input-ip 222.222.222.222 vrf Mgmt-MPEG-video-intf-vrf input-port-number
222
  vcg vcg-vei
  vei-bundle 40000 input-port-number 33,44,66,77,222
active

```

Feature Information for Table Based Configuration

Use Cisco Feature Navigator to find information about the platform support and software image support. Cisco Feature Navigator enables you to determine which software images support a specific software release, feature set, or platform. To access Cisco Feature Navigator, go to the www.cisco.com/go/cfn link. An account on the Cisco.com page is not required.



Note The following table lists the software release in which a given feature is introduced. Unless noted otherwise, subsequent releases of that software release train also support that feature.

Table 8: Feature Information for Table Based Configuration

Feature Name	Releases	Feature Information
Table based configuration	Cisco IOS XE Everest 16.5.1 Cisco IOS XE Everest 16.6.1	This feature was integrated on the Cisco cBR Series Converged Broadband Routers.



CHAPTER 9

Management IP Interface

The management interface is used for the video control plane messages, such as session creation and deletion, between the Logical Edge Devices (LED) and the external Edge Resource Manager (ERM) server.

Contents

- [Information About Management IP Interface](#) , on page 43
- [How to Configure the Management IP Interface](#), on page 43
- [Configuration Examples](#), on page 46
- [Feature Information for Management IP Interface](#), on page 46

Information About Management IP Interface

Video Logical Edge Device (LED) communicates with an external Edge Resource Manager (ERM) and a D6 server via the management interface. The physical interface for the connection is a front panel WAN port.

The following are the characteristics of the management interface:

- The management interface configuration is applied on both active and standby supervisor. However, only the active supervisor's management interface is connected to the external server.
- VirtualPortGroup interface must be configured prior to configuring the cable video management interface.
- Cable video management interface must be configured prior to configuring an LED that uses the management interface.

How to Configure the Management IP Interface

This section describes how to configure the management IP interface for the video session on Cisco cBR-8.

Configuring the Management IP Interface consists of the following three steps:

- [Configuring the VirtualPortGroup Interface](#), on page 44
- [Configuring the Cable Video Management Interface](#), on page 45
- [Configuring the LED Management Interface](#), on page 45

Configuring the VirtualPortGroup Interface

First step towards configuring the Management IP Interface is to configure a VirtualPortGroup interface. You can also configure secondary IP addresses on the VirtualPortGroup interface, similar to a gigabit Ethernet interface IP address configuration.

To configure the VirtualPortGroup interface, complete the following procedure:

```
configure terminal
interface VirtualPortGroup virtual port group number
ip address ip address subnet-mask
ip address ip address subnet-mask secondary
end
```

Verifying the VirtualPortGroup Interface Configuration

To verify the VirtualPortGroup interface configuration, use the **show run interface VirtualPortGroup** command as shown in the example below:

```
show run interface VirtualPortGroup 0
Building configuration...

Current configuration : 145 bytes
!
interface VirtualPortGroup0
 ip address 1.22.3.1 255.255.255.0 secondary
 ip address 1.22.2.1 255.255.255.0
 no mop enabled
 no mop sysid
end
```

The VirtualPortGroup interface is in a down state. The interface comes up after the cable video management interface is configured.

Verifying the VirtualPortGroup Interface State

To verify the VirtualPortGroup interface state, use the **show interfaces VirtualPortGroup** command as shown in the example below:

```
show interfaces VirtualPortGroup 0
VirtualPortGroup0 is up, line protocol is up
 Hardware is Virtual Port Group, address is badb.ad09.7077 (bia badb.ad09.7077)
 Internet address is 1.22.2.1/24
 MTU 1500 bytes, BW 2500000 Kbit/sec, DLY 1000 usec,
   reliability 255/255, txload 1/255, rxload 1/255
 Encapsulation ARPA, loopback not set
 Keepalive not supported
 ARP type: ARPA, ARP Timeout 04:00:00
 Last input never, output 00:24:14, output hang never
 Last clearing of "show interface" counters never
 Input queue: 0/375/0/0 (size/max/drops/flushes); Total output drops: 0
 Queueing strategy: fifo
 Output queue: 0/40 (size/max)
 5 minute input rate 0 bits/sec, 0 packets/sec
 5 minute output rate 0 bits/sec, 0 packets/sec
   0 packets input, 0 bytes, 0 no buffer
   Received 0 broadcasts (0 IP multicasts)
   0 runts, 0 giants, 0 throttles
   0 input errors, 0 CRC, 0 frame, 0 overrun, 0 ignored
   0 input packets with dribble condition detected
```

```

0 packets output, 0 bytes, 0 underruns
0 output errors, 0 collisions, 0 interface resets
0 unknown protocol drops
0 babbles, 0 late collision, 0 deferred
0 lost carrier, 0 no carrier
0 output buffer failures, 0 output buffers swapped out

```

Troubleshooting Tips

- To check if the management interface IP route is up, use the following command:

```

show ip interface brief | include VirtualPortGroup 0
VirtualPortGroup0 1.22.2.1 YES NVRAM up up

```

- To ping the VirtualPortGroup interface, use the following command:

```

ping 1.22.2.1
Type escape sequence to abort.
Sending 5, 100-byte ICMP Echos to 1.22.2.1, timeout is 2 seconds:
!!!!
Success rate is 100 percent (5/5), round-trip min/avg/max = 1/1/1 ms

```

Configuring the Cable Video Management Interface

Before You Begin

VirtualPortGroup interface must be configured before configuring the cable video management.

To configure the cable video management interface, complete the following procedure:

```

configure terminal
cable video
mgmt-interface VirtualPortGroup virtual port group number
end

```

Verifying the Cable Video Management Interface Configuration

To verify the VirtualPortGroup interface configuration, use the **show run | include mgmt-intf** command as shown in the example below:

```

show run | include mgmt-intf
mgmt-intf VirtualPortGroup 0

```

Configuring the LED Management Interface

Before You Begin

- Cable video management interface must be configured before configuring an LED that uses the management interface.
- Management IP address and the VirtualPortGroup IP address must be in the same subnet.

To configure the LED management interface, complete the following procedure:

```

configure terminal
cable video
logical-edge-device device name

```

```
protocol gqi
mgmt-ip management ip address
exit
```

Verifying the LED Management Interface Configuration

To verify the VirtualPortGroup interface state, use the **show run | begin logical-edge-device test** command as shown in the example below:

```
sh run | begin logical-edge-device test
logical-edge-device test id 2
protocol gqi
mgmt-ip 1.22.2.10
```

Troubleshooting Tips

To ping the management interface, use the following command:

```
video-LWR-S-C2# ping 1.22.2.10
Type escape sequence to abort.
Sending 5, 100-byte ICMP Echos to 1.22.2.10, timeout is 2 seconds:
!!!!
Success rate is 100 percent (5/5), round-trip min/avg/max = 1/1/1 ms
```

Configuration Examples

This section provides configuration examples for the management IP interface.

Management IP Interface

The following example shows how to create a management IP interface:

```
configure terminal
interface VirtualPortGroup 0
ip address 1.23.2.1 255.255.255.0
cable video
mgmt-interface VirtualPortGroup 0
logical-edge-device test id 2
protocol gqi
mgmt-ip 1.23.2.10
exit
exit
```

Feature Information for Management IP Interface

Use Cisco Feature Navigator to find information about the platform support and software image support. Cisco Feature Navigator enables you to determine which software images support a specific software release, feature set, or platform. To access Cisco Feature Navigator, go to the www.cisco.com/go/cfn link. An account on the Cisco.com page is not required.



Note The following table lists the software release in which a given feature is introduced. Unless noted otherwise, subsequent releases of that software release train also support that feature.

Table 9: Feature Information for Management IP Interface

Feature Name	Releases	Feature Information
Management IP Interface	Cisco IOS XE Everest 16.5.1 Cisco IOS XE Everest 16.6.1	This feature was integrated on the Cisco cBR Series Converged Broadband Routers.



CHAPTER 10

Video Encryption

The Cisco cBR-8 supports PowerKey and Privacy Mode Encryption (PME) encryption CA systems for Video On Demand (VOD) sessions to address security concerns. However, only one encryption type can be installed on the line card. There are two levels to the CA system. The lower level encrypts the actual data streams. The upper level specifies the control words that are used to encrypt the data streams.

- [Information About Encryption, on page 49](#)
- [How to Configure Encryption for the Data Stream, on page 50](#)
- [Configuration Examples for Encryption, on page 51](#)
- [Configuring Privacy Mode Encryption, on page 51](#)
- [Feature Information for Encryption, on page 54](#)

Information About Encryption

The encrypted sessions can be created on any QAM carriers on a line card. Only the Single Program Transport Stream (SPTS) VOD session can be encrypted. Encryption is not supported on the Pass-through, and Data-piping sessions.

The VOD session can be encrypted in any of the following types of encryption:

- PowerKey for video session management protocol GQI
- Privacy Mode Encryption (PME) for Table-based session
- Digital Video Broadcasting (DVB)

The scrambler mode varies based on the type of encryption, as given in the following table:

Table 10: Supported Encryption Types and Scrambler Modes

Encryption Type	Scrambler Mode
PowerKey	DES, 3DES
PME	DVS-042
DVB	DVB-CSA

Prerequisites for Encryption

You should configure the Virtual Carrier Group (VCG) to setup an encrypted session. For more details, see the [Configuring Virtual Carrier Group, on page 50](#).

How to Configure Encryption for the Data Stream

This section describes how to configure encryption for the video session on Cisco cBR-8.

- [Enforcing Data Stream Encryption Type, on page 50](#)
- [Configuring Virtual Carrier Group, on page 50](#)
- [Verifying Encryption Configuration, on page 51](#)

Enforcing Data Stream Encryption Type



Note Once the line card and VCG are configured for PowerKey encryption, further configuration of the Cisco cBR-8 is not required.

To configure the encryption type for a VOD session, perform the following steps:

Before You Begin

Configure the Virtual Carrier Group (VCG) to setup an encrypted session. For more details, see .

```
enable
configure terminal
cable video
encryption
linecard slot/bay ca-system [dvb | pme | powerkey] scrambler scrambler-type
exit
```

Configuring Virtual Carrier Group

To configure the Virtual Carrier Group (VCG) for setting up an encrypted session, perform the following steps:

```
enable
configure terminal
cable video
virtual-carrier-group name [id #]
rf-channel start-channel#-end-channel# tsid start-tsid-end-tsid output-port-number
start-number-end-num
virtual-edge-input ipaddr input-port-number #
encrypt
exit
```

Verifying Encryption Configuration

To verify the encryption configurations, use the following command:

```
show cable video encryption linecard [all | slot number]
```

Example 1:

```
Router#show cable video encryption linecard 7/0 Line card: 7/0
CA System Scrambler
=====
powerkey des
```

Example 2:

```
Router#show cable video encryption linecard all Line card: 7/0
CA System Scrambler
=====
powerkey des
```

Configuration Examples for Encryption

This section provides configuration examples for the Encryption feature.

Example: Enforcing Data Stream Encryption Type

The following is a sample in which the line card in slot 7 is configured for powerkey encryption.

```
Router(config)#cable video Router(config-video)#encryption
Router(config-video-encrypt)#linecard 7/0 ca-system powerkey scrambler des
```

Example: Configuring Virtual Carrier Group

The following is a sample in which the QAM channel from 64 to 158 are encryption capable if the virtual channels are successfully bound to a Service Distribution Group. The sessions created on those QAM carriers are encrypted using the scrambler installed on the line card.

```
Router(config)#cable video
Router(config-video)#virtual-carrier-group sdv-grp
Router(config-video-vcg)#rf-channel 64-158 tsid 64-158 output-port-number 64-158
Router(config-video-vcg)virtual-edge-input 14.1.1.1 input-port-number 1
Router(config-video-vcg)encrypt
Router(config-video-vcg)#exit
```

Configuring Privacy Mode Encryption

Only one device from the MSO site can communicate with the Encryption Renewal System (ERS) and obtain the latest ECM templates. The CEM communicates with the ERS and sends the ECM templates to the Cisco Edge QAM devices in the MSO site.

You can configure the following:

- VODS-ID—IDs assigned by CCAD or ARRIS to the MSO site. The configured VODS-ID on the Cisco cBR-8 and the CEM must be same.
- CEM IP—Interface IP of the Windows/Linux system through which the CEM can be reached by Cisco cBR-8.

- CEM Port—Port number on which the CEM listens for connections from the Cisco cBR-8.
- Management Interface—Source IP address of the Cisco cBR-8 virtual interface through which the connection must be established with the CEM server.



Note There can be only one entry for VODS-ID, CEM IP, CEM Port, and Management Interface IP. If you configure any new values for these parameters, the previous configuration is cleared. You can clear the configurations using the 'no' form of the command.

Configuring VODS-ID

To configure the VODS-ID of the CEM, perform the following steps:

```
enable
configure terminal
cable video
encryption
pme vodsid id
exit
```

Configuring CEM IP and Port

To configure the CEM IP and port of the CEM, perform the following steps:

```
enable
configure terminal
cable video
encryption
pme cem ip-address tcp_port
exit
```

Configuring Management IP

To configure the PME management IP address to establish CEM connection, perform the following steps:

Before You Begin

The virtual port group must be configured before configuring the management IP. For more information, see the *Configuring a VirtualPortGroup iLterface* section.

```
enable
configure terminal
cable video
encryption
pme mgmt-ip ip-address
exit
```

Verifying PME Connection Status

To verify the connection status between the Cisco Converged EdgeQAMManager (CEM) application and the Cisco cBR-8, use the following command:

```
show cable video encryption linecard [all | slot number]
```

This command displays the following information:

- VODS-ID—Specifies the configured VODS-ID on the CEM and Cisco cBR-8.
- CEM IP—Specifies the IP through which CEM can be reached by Cisco cBR-8.
- CEM Port—Specifies the port on which the CEM obtain connections from Cisco cBR-8.
- Local Mgmt IP—Specifies the Cisco cBR-8 interface through which the connection is established with the CEM.
- Local Port—Specifies the Local Port number assigned for the connection with the CEM.
- CEM Connection State—Specifies the status of the connection with the CEM (Connected (or) Not Connected).
- Count of ECMs recd—Specifies the count of ECMs received from the CEM.

Example:

This is a sample output of the show command that displays the connection status of PME.

```
Router#show cable video encryption pme status  
PME Connection Status:  
VODS-ID : 111  
CEM IP : 1.200.1.163  
CEM Port : 5000  
Local Mgmt IP : 1.24.2.6  
Local Port : 50394  
CEM Connection State : Connected Count of ECMs recd : 2
```

Verifying PME Version

To verify the version information of the PME module loaded in the chassis, use the following command:

```
show cablevideo encryption pme version
```

The version information is read from the IOS PME subsystem. The version information displays in MAJOR.MINOR version format.

Example:

This is a sample output of the show command that displays the version details of PME.

```
Router#show cable video encryption pme version  
PME Version: 1.0
```

Verifying PME Sessions on a Line Card

To verify the sessions that use the PME modules that are loaded on a specific line card, use the following command:

```
show cable video encryption pme linecard [slot | bay] session {1-65535 | all | summary}
```

Example 1:

This is a sample output of the show command that displays the session details that use PME modules.

```
Router#show cable video encryption pme linecard 7/0 session all Count of ECMG Streams: 4
===== ECMG Stream DATA =====
Stream
ID num EcmId CP# CwE CPDur NomCPD EcmRqst EcmRsp
-----
0020(0032) 0020(0032) 0002 0 0 40000 7 2
0021(0033) 0021(0033) 0002 0 0 40000 7 2
0040(0064) 0040(0064) 0002 0 0 40000 7 2
0041(0065) 0041(0065) 0002 0 0 40000 7 2
video-LWR-B-A7B#show cable video encryption pme linecard 7/0 session 32 Stream 32, session
7681 is active

Stream number = 32 Session number = 7681
ECM requests = 8 ECM replies = 2
ECM ID = 32 CryptoPeriod num = 2
CP duration = 0 Nominal duration = 40000
CA transfer mode = 1 Stream status = No Error Blob details

video-LWR-B-A7B#show cable video encryption pme linecard 7/0 session summary Currently
active streams:
Active = 4 ECM req/resp mismatch = 4
ECM req, all streams = 32 ECM resp, all streams = 8

Since last reset:
Sessions created = 4 Sessions deleted = 0
ECMs received = 2 ECMs discarded = 0
```

Feature Information for Encryption

Use Cisco Feature Navigator to find information about the platform support and software image support. Cisco Feature Navigator enables you to determine which software images support a specific software release, feature set, or platform. To access Cisco Feature Navigator, go to the www.cisco.com/go/cfn link. An account on the Cisco.com page is not required.



Note The following table lists the software release in which a given feature is introduced. Unless noted otherwise, subsequent releases of that software release train also support that feature.

Table 11: Feature Information for Encryption

Feature Name	Releases	Feature Information
Encryption	Cisco IOS XE Everest 16.5.1 Cisco IOS XE Everest 16.6.1	This feature was integrated on the Cisco cBR Series Converged Broadband Routers.



CHAPTER 11

Global Video Configuration

You can perform some global configurations for provisioning the video services. These configurations have some default values. If you do not choose to change those values, the default values are used. The following sections describe the procedures for global configurations.

Contents

- [Configuring the Default ONID, on page 55](#)
- [Configuring the Default PSI interval, on page 55](#)
- [Configuring Video Session Timeouts, on page 56](#)
- [Configuration Examples, on page 56](#)
- [Feature Information for Global Video Configuration, on page 56](#)

Configuring the Default ONID

By default, the system ONID is 0, which is commonly used in North America. If the default value of the ONID is used, the TSID must be unique. You can change the default ONID. If you change the ONID, the TSID-ONID pair must be unique. The ONID must be in the range of 0 to 65535.

```
configure terminal
cable video
default-onid default onid number
```

Configuring the Default PSI interval

By default, the Program Specific Information (PSI) interval is 100 msec. You can change the default PSI interval. The PSI interval must be in the range of 40 to 1000.

```
configure terminal
cable video
default-psi-interval default-psi-interval msec
```

Configuring Video Session Timeouts

The default video session init timeout is 1000 msec, the idle session timeout is 250 msec, and the off session timeout is 60 seconds. You can change these default values. The following are the permissible ranges for the timeouts:

- Init session timeout—100 to 60000
- Idle session timeout —100 to 5000
- Off session timeout —1 to 1800

```
configure terminal
cable video
timeout init-session timeout msec
timeout idle-session timeout msec
timeout off-session timeout sec
```

Configuration Examples

This section provides examples for the global video configuration.

Example: Global Video Configuration

```
configure terminal
cable video
default-onid 10
default-psi-interval 50
timeout init-session 200 msec
timeout idle-session 250 msec
timeout off-session 500 sec
```

Feature Information for Global Video Configuration

The following table provides release information about the feature or features described in this module. This table lists only the software release that introduced support for a given feature in a given software release train. Unless noted otherwise, subsequent releases of that software release train also support that feature.

Use Cisco Feature Navigator to find information about platform support and Cisco software image support. To access Cisco Feature Navigator, go to www.cisco.com/go/cfn. An account on Cisco.com is not required.

Table 12: Feature Information for Global Video Configuration

Feature Name	Releases	Feature Information
Global Video Configuration	Cisco IOS XE Everest 16.5.1 Cisco IOS XE Everest 16.6.1	This feature was integrated on the Cisco cBR Series Converged Broadband Routers.



CHAPTER 12

Advanced Video MPEG Features

Cisco cBR Series Converged Broadband Router supports the following video features.

- [Information about Advanced Video MPEG Features, on page 59](#)
- [How to Configure Advanced Video MPEG Features, on page 59](#)
- [Configuration Examples for Advanced Video MPEG Features, on page 60](#)
- [Feature Information for Advanced Video MPEG Features, on page 60](#)

Information about Advanced Video MPEG Features

Reserved Output PID Range

The reserved output PID range allows the user to specify a range of PIDs that will not be used as output for remapped sessions. A range of up to 4000 PIDs from 1-8190 can be reserved.

One continuous reserved PID range is supported for each chassis. Note that the protection is only good for future output remapped PIDs, so the reserved PID range is expected to be configured before any remapped sessions are created. Remapped PIDs within the reserved range that already exists will not be reallocated.

How to Configure Advanced Video MPEG Features

Configuring Reserved Output PID Range

To configure reserved output range, follow the steps below:

```
enable
configure terminal
cable video
reserve-pid-range start-pid-end-pid
```

Verifying Reserved Output PID Range Configuration

To verify the reserved output PID range configuration, use the **show cable video logical-edge-device id id reserve-pid-range** command as shown in the example below.

```
Router# show cable video logical-edge-device id 1 reserve-pid-range
Logical Edge Device: led1
Id: 1
Reserve PID Range: 1-4000
```

Configuration Examples for Advanced Video MPEG Features

This section provides configuration examples for the advanced video MPEG features:

Example: Configuring Reserved Output PID Range

The following example shows how to configure reserved output PID range.

```
enable
configure terminal
cable video
reserve-pid-range 4000-4100
```

Feature Information for Advanced Video MPEG Features

Use Cisco Feature Navigator to find information about the platform support and software image support. Cisco Feature Navigator enables you to determine which software images support a specific software release, feature set, or platform. To access Cisco Feature Navigator, go to the www.cisco.com/go/cfn link. An account on the Cisco.com page is not required.



Note The following table lists the software release in which a given feature is introduced. Unless noted otherwise, subsequent releases of that software release train also support that feature.

Table 13: Feature Information for Advanced Video MPEG Features

Feature Name	Releases	Feature Information
Advanced Video MPEG Features	Cisco IOS XE Everest 16.6.1	This feature was integrated on the Cisco cBR Series Converged Broadband Routers.



CHAPTER 13

Important Notes

The following are some important notes for Management IP Interface and Virtual Routing Interface.

- [Video Packet Routing Requirements, on page 61](#)

Video Packet Routing Requirements

A routing protocol, such as OSPF or IS-IS, must be enabled on the cBR-8 in order for video data packets from the head end to reach the virtual QAMs. On the cBR-8, enable a routing protocol as described in the routing configuration guide.

Once the routing protocol is set up correctly, the cBR-8 will advertise the internal static routes for the video data path to the head end.

The user needs to configure the Virtual Edge Input (VEI) with a routable IP address from within the customer's network. More information, see [Configuring Virtual Edge Input under Logical Edge Device](#).



PART II

Cisco cBR Converged Broadband Routers Video Features

- [PowerKEY VOD, on page 65](#)
- [Table-Based Video and VPME Encryption , on page 73](#)
- [PMV Support for Table-Based Videos, on page 89](#)
- [Video QAM Replication, on page 99](#)
- [D6 Discovery Protocol, on page 105](#)
- [Switched Digital Video, on page 115](#)
- [DVB Video on Demand, on page 127](#)
- [DualCrypt Encryption Mode Support, on page 137](#)
- [Low Latency VOD Support, on page 149](#)
- [Video MIBs, on page 155](#)



CHAPTER 14

PowerKEY VOD

PowerKEY Video On Demand refers to video content that is chosen by the subscriber and streamed specifically to the subscriber. The content is encrypted using PowerKEY conditional access through a video session that is created on the Cisco cBR-8 specifically for each request.

Contents

- [Information About PowerKEY VOD, on page 65](#)
- [How to Configure PowerKEY VOD, on page 65](#)
- [Configuration Examples, on page 71](#)
- [Feature Information for PowerKEY VOD, on page 72](#)

Information About PowerKEY VOD

PowerKEY Video On Demand is used in a Cisco cable environment to provide edge-encrypted video-on-demand movies and other content to subscribers. The subscriber selects the content via an on-screen selection and the set-top box (STB) notifies the head-end of the request. The head-end equipment receives the request from the STB and triggers the Session Resource Manager (SRM) to create an encrypted video session on the Cisco cBR-8. At the same time, the video streamer is triggered to begin streaming the content in a UDP stream to the Cisco cBR-8. The Cisco cBR-8 receives an unscrambled video content, encrypts it using PowerKEY, combines the scrambled stream with other content destined for the RF carrier, and transmits the RF signal from the RF port.

PowerKEY VOD allows the operator to provide secure, encrypted video streams to a particular subscriber over the RF plant.

Overview of PowerKEY VOD

PowerKEY VOD allows the operator to provide secure, encrypted video streams to a particular subscriber over the RF plant.

How to Configure PowerKEY VOD

- [Configuring the Encryption Type on the Line Card](#)
- [Configuring the Encrypted Virtual Carrier Groups](#)

- [Configuring the Service Distribution Groups and Binding](#)
- [Configuring the Logical Edge Device and GQI Protocol](#)
- [Verifying the PowerKEY VOD Configuration](#)

Configuring the Encryption Type on the Line Card

The Cisco IOS-XE Release 16.5.1 supports PowerKey and PME encryption CA systems, but allows only one encryption type to be installed on the line card. There are two levels in the CA system. The lower level scrambler, which encrypts the actual data streams and the upper level conditional access system, which handles how the control words are transferred from the encrypting device to the decrypting device.

To specify the type of encryption used to scramble the data streams, complete the following procedure:

```
configure terminal
cable video
encryption
linecard slot/bay ca-system [pme | powerkey] scrambler scrambler-type
exit
```

PowerKey currently supports DES and Privacy Mode Encryption (PME) supports DVS-042 type of encryption, as given in the following table:

Table 14: Supported Encryption Types and Scrambler Modes

Encryption Type	Scrambler Mode
PME	DVS-042
PKEY	DES, 3DES

Verifying the Encryption Configuration

To verify the encryption type of a line card, use the **show cable video encryption linecard** command as shown in the example below:

```
show cable video encryption linecard 7/0
Line card: 7/0
CA System      Scrambler
-----
powerkey      des
```

Configuring the Encrypted Virtual Carrier Groups

For the sessions to be encrypted on the Cisco cBR-8, the Virtual Carrier Groups (VCGs) must be specified as **encrypt** and the line card must be configured as encrypted. In this way, the operator can choose the carriers on the line card that support encryption and other carriers that support only clear or pre-encrypted sessions. Each encrypted carrier consumes an encrypted carrier license.

For the VCG to be used in a Logical Edge Device (LED) that is configured with the GQI protocol, each RF carrier must be assigned with an output port number. The LED must be configured with the Generic QAM Interface (GQI) protocol in order to support session-based operation.



Note For PowerKEY VOD, you have to specify the session-based operation.

To configure the VCG, complete the following procedure:

```
configure terminal
cable video
virtual-carrier-group vcg-name
rf-channel channel range tsid tsid range output-port-number port num range
virtual-edge-input ip-address [vrf] vrf name input-port-number number
encrypt
exit
```

Verifying the Encrypted Virtual Carrier Groups Configuration

To verify the encrypted VCGs configuration, use the **show cable video virtual-carrier-group name** command as shown in the example below:

```
show cable video virtual-carrier-group name vod-grp
```

Configuring the Service Distribution Groups and Binding

The Service Distribution Group (SDG) is a collection of one or more RF ports and defines the physical slot/bay/port to be used in a video service. After you configure an SDG, you can bind a VCG to an SDG. The binding connects the carriers defined in the VCG to the physical port listed in the SDG. After binding, a path from the Virtual Edge Input (VEI) is mapped to the RF ports.

To configure the SDGs and binding, complete the following procedure:

```
configure terminal
cable video
service-distribution-group sdg name id sdg number
onid onid for port
rf-port integrated-cable slot/bay/port
exit
bind-vcg
vcg vcg-name sdg sdg-name
end
```

Configuring the Logical Edge Device and GQI Protocol

The PowerKEY VOD feature on the Cisco cBR-8 is directed by an external Session Resource Manager (SRM) that creates video sessions in response to a subscriber selecting VOD content to watch on the set top box. You must configure a Logical Edge Device (LED) supporting the GQI protocol on the Cisco cBR-8 to support the PowerKEY VOD.

The LED is configured with the GQI protocol as the LED communicates with an external SRM using the GQI protocol. The GQI protocol supports the creation and deletion of sessions on the carriers owned by this LED.



Tip Use the following command to get the chassis MAC address:

```
Router#show diag all eeprom detail | include MAC
Chassis MAC Address : 54a2.740e.2000
MAC Address block size : 1024
```

Using the Chassis MAC as a basis, increment the least significant number to give a unique identifier (mac-address) for each LED. This number needs to be unique with respect to the GQI server and does not really relate to a true MAC address. Thus, the number is irrelevant, but needs to be unique.

To configure the Logical Edge Device and GQI Protocol, complete the following procedure:

```
configure terminal
cable video
logical-edge-device led name id led number
protocol gqi
mgmt-ip management ip address
mac-address mac address from this chassis range
server ip address of srm
virtual-edge-input-ip ip addr for content [vrf] vrf name input-port-number num
vcg virtual edge qam name (may be multiple vcgs in an LED)
active n
end
```

Verifying the PowerKEY VOD Configuration

The PowerKEY encrypted VOD LED is active and communicates with the external SRM device after configuring the encryption type on the line card, VCGs, binding of SDGs, and LED with GQI protocol are completed.

To verify the Logical Edge Device configuration, use the **show cable video logical-edge-device name led name** command (or) **show cable video logical-edge-device id led number** command as shown in the example below:

```
show cable video logical-edge-device name pkvodled
Logical Edge Device: pkvodled
Id: 1
Protocol: GQI
Service State: Active
Discovery State: Disable
Management IP: 1.23.2.10
MAC Address: 54a2.740d.dc99
Number of Servers: 1
Server 1: 1.200.3.75
Reset Interval: 8
Keepalive Interval: 10   Retry Count:3
Number of Virtual Carrier Groups: 1
Number of Share Virtual Edge Input: 1
Number of Physical Qams: 20
Number of Sessions: 0
No Reserve PID Range

Virtual Edge Input:
Input Port   VEI           Slot/Bay     Bundle       Gateway
ID           IP            ID           ID           IP
```

```
-----
1          174.10.2.1          7/0          -          -
```

Verify the following:

- The service state of the LED should be active and the other fields must be same as the configured values.
- The connection to the remote SRM should be displayed to ensure that there is a valid network connection to the SRM.
- Execute the **show cable video gqi connections** command. The following is the sample output when the connection is not established to the SRM :

```
LED Management Server      Connection  Version  Event  Reset  Encryption
ID  IP          IP          Status    Status  Pending Indication Discovery
-----
1   1.23.2.10  1.200.3.75 Not Connected  0      0      Not Sent  Not Sent
```

The following is the sample output when the connection is established to the SRM:

```
LED Management Server      Connection  Version  Event  Reset  Encryption
ID  IP          IP          Status    Status  Pending Indication Discovery
-----
1   1.23.2.10  1.200.3.75 Not Connected  2      0      ACKED     ACKED
```

Once the connection is established, the SRM may create encrypted sessions on the carriers of the LED.

- To view the encrypted sessions, use the **show cable video session logical-edge-device id led name summary** command as shown in the example below:

```
show cable video session logical-edge-device id 1summary
Video Session Summary:

Active      : 1      Init       : 0      Idle       : 0
Off         : 0      Blocked    : 0      PSI-Ready  : 1
UDP        : 1      ASM        : 0      SSM        : 0
Remap      : 1      Data       : 0      Passthru   : 0
Total Sessions: 1
```

- The individual session information can be displayed for the entire LED, for a particular port or line card. The details of a single session may be displayed by specifying a session-id or session-name. To display all the sessions on the LED, use the **show cable video session logical-edge-device name led name** command as shown in the example below:

```
show cable video session logical-edge-device name pkvodled
Total Sessions = 1

Session Output Streaming Session Destination UDP  Output  Input      Output Input
Id      Port  Type  Type  Destination  Port  Program State  State  Bitrate
-----
1048576 1     Remap  UDP   174.101.1.1  4915  1      ACTIVE-PSI ON  732788

Output  Encrypt  Encrypt  Session
Bitrate Type  Status   Name
-----
1715446 PowerKey Encrypted 0x0000000000001
```

If the session is encrypted and transmitted properly, the session is displayed as shown in the above example. The input state is "ACTIVE-PSI". The output state is "ON". For PowerKEY encrypted sessions, the Encrypt Type will be "PowerKey" and the Encrypt Status will be "Encrypted".

If the session is created as a clear session, then the Encrypt Type will be "CLEAR" and the Encrypt Status will be "-".

If the GQI connection is not in connected state or if the sessions are not in the proper states then, troubleshoot the connection. For more information, see [Troubleshooting Tips, on page 70](#).

Troubleshooting Tips

GQI Connection

GQI connection problems can be the result of a problem in the network, such as a problem in the external SRM device, or in the Cisco cBR-8 configuration. The first problem is beyond the scope of this document, however to verify the Cisco cBR-8 configuration, the management interface port must be configured properly and be active (not shutdown).

Session Input State

- If a session's input state is "OFF" or another state that is not "ACTIVE_PSI" then the problem is related to content receiving on the Cisco cBR-8. This could be a problem elsewhere in the head-end network or with the video streaming device. The Virtual Edge Input address specified in the LED should match the destination IP address used by the streaming device.

To display the LED, use the following command:

```
show cable video logical-edge-device id led number
```

- The Virtual Edge Inputs are listed in the output. Check the streaming device to ensure the destination IP address matches the appropriate VEI. Additionally, verify whether the UDP port of the video content from the streamer matches the UDP port shown in the session display on the Cisco cBR-8, using the following command:

```
show cable video session logical-edge-device id led number
```

- The TenGigabitEthernet port where the VEI address is routed must not be in the shutdown state. To check the appropriate interface, use the following command:

```
show interface TenGigabitEthernet slot/bay/port
```

Session Output State

- If a session's input state is "Active-PSI" and the output state is not "OFF", then the problem is related to the physical port channel configuration. The output of the **show logical edge device** command also shows all the carriers and their Admin and Operation state.

To display the carriers and their state, use the following command:

```
show cable video scg logical-edge-device id number
```

```
show cable video logical-edge-device id number
Integrated Physical Admin Operational TSID ONID Output VCG SDG Encryption
Cable QAM ID State State Port ID ID Capable
-----
8/0/0:0 0 ON UP 1 100 1 1 1 powerkey
```

```

8/0/0:1    1      ON    UP      2    100   2     1     1     powerkey
8/0/0:2    2      ON    UP      3    100   3     1     1     powerkey
8/0/0:3    3      ON    UP      4    100   4     1     1     powerkey

```

- If the output port corresponding to the session does not show "ON" for Admin State and an Operational State as "UP", then there is a problem with the configuration. To display the output port details, use the following command:

```
show cable video output-port output port number
```

Session Encrypt Status

- If an encrypted GQI session has an Output State or Encrypt Status of "Pending", it means there is a problem with the PowerKEY encryption of the session, or it is possible the encryption on the session is just getting ready to start. First the session command should be executed over a few seconds to ensure that the session was not transitioning from Pending to Active. If the state is Pending, then there is a problem with the encryption.

To troubleshoot this problem the operator can check the Scrambling Control Group (SCG) that corresponds to this session. Using the session id from the session display, the SCG ID can be found using the following command:

```
show cable video scg logical-edge-device id led number
```

```
LED 1 has 8137 SCGs on 128 carriers
```

```

SCG ID      Session ID  LED  TSID  ONID
-----
68157683    1048819    1    1     100
68157684    1048820    1    1     100

```

To verify the SCG ID of the session, use the following command:

```
show cable video scg logical-edge-device id led number | inc session id
```

```
68157684    1048820    1    1     100
```

To verify the SCG session information, use the following command:

```
show cable video scg id SCG id
```

```

SCGid: 68157684
Status: SUCCESS
TSID: 1
ONID: 100
Nominal CP: 550

```

If the Status does not show SUCCESS, then there must be a problem with the Encrypted Key exchange between the Cisco cBR-8 and SRM.

Configuration Examples

This section provides configuration examples for the PowerKEY VOD feature:

Example: Configuring Encryption Type on the Line Card

The following example shows how to create a management IP interface:

```
configure terminal
cable video
encryption
linecard 7/0 ca-system powerkey scrambler des
exit
```

Example: Configuring Encrypted Virtual Carrier Groups

The following example shows how to configure the QAM channels from 64 to 158. These channels are encryption capable once the VCG is successfully bound to a Service Distribution Group. The sessions created on these QAM carriers are encrypted using the scrambler installed on the line card.

```
configure terminal
cable video
virtual-carrier-group vod-group
rf-channel 64-158 tsid 64-158 output-port-number 64-158
virtual-edge-input-ip 14.1.1.1 input-port-number 1
virtual-edge-input-ip 14.2.1.1 vrf Video-VOD-Vrf input-port-number 2
encrypt
exit
```

Example: Configuring Service Distribution Groups and Binding

The following example shows how to configure the service distribution groups and binding:

```
configure terminal
cable video
logical-edge-device pkvodled id 1
protocol gqi
mgmt-ip 1.20.2.10
mac-address 54ab.6409.dc99
server 1.200.3.75
virtual-edge-input-ip 174.10.2.1 input-port-number 1
virtual-edge-input-ip 174.11.2.1 vrf Video-VOD-Vrf input-port-number 2
vcg vod-grp
active n
end
```

Feature Information for PowerKEY VOD

Table 15: Feature Information for PowerKEY VOD

Feature Name	Releases	Feature Information
PowerKEY VOD	Cisco IOS XE Everest 16.5.1	This feature was integrated on the Cisco cBR Series Converged Broadband Routers.

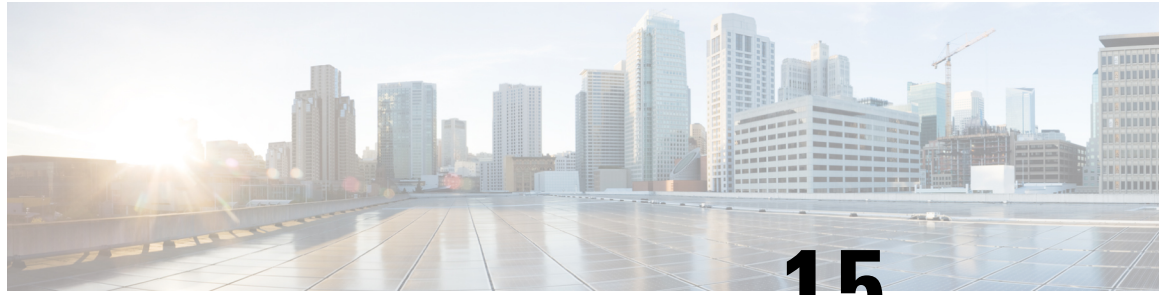

CHAPTER 15

Table-Based Video and VPME Encryption

Table-based video is a configuration mode for video sessions. This feature statically maps UDP flows into appropriate RF QAM channels. Each UDP flow is identified by the destination IP address of the MPEG traffic and UDP port number. The configuration contains the input port number, which is resolved into a unique destination IP address, the UDP port, and an output program number.

The Video on Demand (VOD) Privacy Mode Encryption (PME) enables the Cisco Edge QAM Manager (CEM) to encrypt the VOD content streamed through Motorola/Arris VOD systems. PME encryption is applicable for table-based sessions.

- [Overview of VPME, on page 73](#)
- [How to Configure Table-Based Video Session, on page 74](#)
- [How to Configure VPME Encryption, on page 84](#)
- [Configuration Examples For VPME Encryption, on page 87](#)
- [Feature Information for Table-Based Video and VPME Encryption, on page 88](#)

Overview of VPME

The PME Video On Demand system integrates the encrypted VOD content within an Arris digital cable headend. A VOD system provides the clear content while the Cisco cBR-8 and CEM are added to provide encryption. The details on the usage of the CEM are described in this chapter. Every MSO site should have the CEM application, which is the single entity connecting to the Arris Encryption Renewal System (ERS). All the Cisco cBR-8s on this MSO site should connect to this CEM.

Prerequisites for VPME

To enable VPME encryption, the connection to the CEM should be configured. VPME is a licensed feature and requires appropriate license on the chassis. The following connection should be configured:

- The video traffic flow on the Ten Gigabit interface.
- Table-based video sessions.
- QAM PHY parameters for the physical QAM channel.

Restrictions for VPME

You can configure the line card in only one mode as the table-based session configuration and dynamic GQI-based sessions are mutually exclusive. Hence, PME and PowerKey encryption are also mutually exclusive modes at the line card level. For more details, see *Configuring the Encryption Type on the Line Card* section.

How to Configure Table-Based Video Session

Configuring Table-Based Video

Before You Begin

Before configuring table-based sessions, you must configure the physical and virtual constructs for Cisco cBR-8. You must also configure the Logical Edge Device (LED), Service Distribution Group (SDG), binding and Virtual Carrier Group (VCG).

The following is an example for LED configuration. In this example, assumes that the video traffic is routed via the input ports of Virtual Edge Input (VEI).

```
logical-edge-device pme_tbv id 1
protocol table-based
virtual-edge-input-ip 172.16.0.1 input-port-number 1
vcg pme_tbv
active
```

In the above example, protocol table-based indicates that this LED supports table-based sessions.

For more information, see the *How to Configure the Logical Edge Devices* section. For details related to D6 protocol, see the *How to Configure the D6 Discovery Protocol* section.

Configuring Table-Based Session : VEI Input Port-Based

To configure the table-based session based on Virtual Edge Input (VEI), complete the following procedure:

```
configure terminal
cable video
table-based
vcg vcg-name
rf-channel n-m
session name {input-port number | bundle-id number}
start-udp-port number num-sessions-per-qam number processing-type
  {program | data } start-program number [repeat] jitter
ms [cbr | vbr ]
exit
```

The **table-based** keyword is the root keyword. The entire table-based configuration should be under this keyword. Within this, the configuration is separated based on the VCG. Within each VCG, the configuration can be created for each QAM channel.

- Processing-type
 - Remap—Configures VoD sessions as remap.
 - Data—Configure video streams that are not dejittered, and remapped. For example, Beacons, carousel, and so on.

- Repeat—Repeats the program number across QAM channels.

Example:

The following is an example in which two sessions are created on all QAM channels from 20 to 22.

```
configure terminal
cable video
table-based
vcg pme_tbv
rf-channel 20-22
session bago_tbv input-port 1 start-udp-port 49152 num-sessions-per-qam 2 processing-type
remap start-program 32 jitter 150 cbr
exit
```

The following is an example in which one session is created on each QAM channel.

```
configure terminal
cable video
table-based
vcg pme_tbv2
rf-channel 23
session pme_tbv input-port 1 start-udp-port 50152 num-sessions-per-qam 1 processing-type
remap start-program 5 jitter 150 cbr
rf-channel 24
session pme_tbv input-port 1 start-udp-port 50153 num-sessions-per-qam 1 processing-type
remap start-program 5 jitter 150 cbr
exit
```

Configuring Table-Based Session :VEI Bundle-Based

Before You Begin

- Create two or more VEIs.
- Bundle the VEIs.

For more details, see *Virtual Edge Input Bundling* section.

To configure the VEI bundled table-based session, complete the following procedure:

```
configure terminal
cable video
table-based
vcg vcg-name
rf-channel n-m
session name bundle-id number start-udp-port
number num-sessions-per-qam number processing-type
{program | passthru | data} start-program number
[repeat] jitter ms [cbr | vbr]
exit
```

Example:

The following is an example in which a session is created for VEI bundle (10) .

```
configure terminal
cable video
table-based
vcg pme_vcg
rf-channel 20-21
session tbv bundle-id 10 start-udp-port 49152 num-sessions-per-qam 2 processing-type remap
```

```
start-program 1 repeat jitter 100 vbr
exit
```

Virtual Edge Input Bundling

To create and bundle the VEIs, complete the following procedure:

```
configure terminal
cable video
logical-edge-device name
protocol table-based
virtual-edge-input-ip ip address input-port-number number
vcg vcg-name
vei-bundle id input-port-number number
active
exit
```

Example:

The following is an example in which a bundle (10) is created with two input ports (1 and 2) each with distinct IP address.

```
configure terminal
cable video
logical-edge-device pme_led id 1
protocol table-based
virtual-edge-input-ip 172.16.0.1 input-port-number 1
virtual-edge-input-ip 172.16.0.1 input-port-number 2
vcg pme_vcg
vei-bundle 10 input-port-number 1,2
active
exit
```

Verifying Table-Based Video Configuration

Verify All Sessions Configured on an LED

To verify all the sessions configured on a particular LED, use the **show cable video session logical-edge-device id number** command as shown in the example below:

```
show cable video session logical-edge-device id 1
Total Sessions = 6
```

Session Id	Output Port	Streaming Encrypt	Session Type	Destination	UDP Port	Output Program	Input State	Output State	Input Bitrate	Output Bitrate
Type	Status	Name	Type		Port	Program	State	State	Bitrate	Bitrate
1048576	1	Remap	UDP	174.21.1.1	49152	32	ACTIVE-PSI	ON	1718234	1702594
CLEAR	-	bago_tbv.1.0.1.20.49152								
1048577	1	Remap	UDP	174.21.1.1	49153	33	ACTIVE-PSI	ON	1718631	1702594
CLEAR	-	bago_tbv.1.0.1.20.49153								
1048578	2	Remap	UDP	174.21.1.1	49154	34	ACTIVE-PSI	ON	1717832	1702977
CLEAR	-	bago_tbv.1.0.1.21.49154								
1048579	2	Remap	UDP	174.21.1.1	49155	35	ACTIVE-PSI	ON	1717322	1702977
CLEAR	-	bago_tbv.1.0.1.21.49155								
1048580	3	Remap	UDP	174.21.1.1	49156	36	ACTIVE-PSI	ON	1718697	1702959
CLEAR	-	bago_tbv.1.0.1.22.49156								
1048581	3	Remap	UDP	174.21.1.1	49157	37	ACTIVE-PSI	ON	1717542	1702959

```
CLEAR - bago_tbv.1.0.1.22.49157
```

verify the summary of the session details

To verify the summary of the session details at a LED level, use the **show cable video session logical-edge-device id number summary** command as shown in the example below:

```
show cable video session logical-edge-device id 1 summary
Video Session Summary:
```

```
Active      : 6      Init       : 0      Idle       : 0
Off         : 0      Blocked   : 0      PSI-Ready  : 6
UDP        : 6      ASM       : 0      SSM        : 0
Remap      : 6      Data      : 0      Passthru   : 0
Total Sessions: 6
```

Verify QAM PHY Parameters of RF-channel

To verify the QAM PHY parameters of RF-channel that are configured on the RF port, which is controller Integrated-Cable 7/0/0, use the **show controllers integrated-Cable slot/bay/portrf-channel n-m** command as shown in the example below:

```
show controllers integrated-Cable 7/0/0 rf-channel 0-95
Chan State Admin Frequency Type Annex Mod srate Interleaver dcid power output
0 UP UP 93000000 VIDEO B 256 5361 I32-J4 - 34 NORMAL
1 UP UP 99000000 VIDEO B 256 5361 I32-J4 - 34 NORMAL
2 UP UP 105000000 VIDEO B 256 5361 I32-J4 - 34 NORMAL
3 UP UP 111000000 VIDEO B 256 5361 I32-J4 - 34 NORMAL
4 UP UP 117000000 VIDEO B 256 5361 I32-J4 - 34 NORMAL
5 UP UP 123000000 VIDEO B 256 5361 I32-J4 - 34 NORMAL
6 UP UP 129000000 VIDEO B 256 5361 I32-J4 - 34 NORMAL
7 UP UP 135000000 VIDEO B 256 5361 I32-J4 - 34 NORMAL
8 UP UP 141000000 VIDEO B 256 5361 I32-J4 - 34 NORMAL
9 UP UP 147000000 VIDEO B 256 5361 I32-J4 - 34 NORMAL
10 UP UP 153000000 VIDEO B 256 5361 I32-J4 - 34 NORMAL
```

Troubleshooting Video and VPME Encryption

Output State is OFF

Procedure

- Step 1** Verify the video traffic using the **show cable video session logical-edge-device id 1** command. In the below example, the output state is OFF. This value confirm that there is no output traffic.

```
Session Output Streaming Session Destination UDP Output Input Output Input Output
Encrypt Encrypt Session Id Port Type Type Port Program State State Bitrate Bitrate
Type Status Name
-----
1048582 1 Remap UDP 172.16.0.1 49152 32 OFF OFF 0 0 PME
Pending bago_tbv.1.0.1.20.49152
1048583 1 Remap UDP 172.16.0.1 49153 33 OFF OFF 0 0 PME
Pending bago_tbv.1.0.1.20.49153
```

Output State is OFF

```

1048584 2 Remap UDP 172.16.0.1 49154 34 OFF OFF 0 0 PME
Pending bago_tbv.1.0.1.21.49154
1048585 2 Remap UDP 172.16.0.1 49155 35 OFF OFF 0 0 PME
Pending bago_tbv.1.0.1.21.49155
1048586 3 Remap UDP 172.16.0.1 49156 36 OFF OFF 0 0 PME
Pending bago_tbv.1.0.1.22.49156
1048587 3 Remap UDP 172.16.0.1 49157 37 OFF OFF 0 0 PME
Pending bago_tbv.1.0.1.22.49157

```

Step 2 Verify if the RF output of the controller is shut using the **show cable video integrated-cable** command.

```
Router#show cable video integrated-cable 8/0/0
```

```

Integrated TSID ONID Output Physical Admin Operational Virtual-Carrier Service-Distribution
Logical-Edge Encryption Total
Cable Port QAM ID State State -Group Name -Group Name
-Device Name Capable Sessions
-----
8/0/0:20 1 0 1 unavailable OFF DOWN pme_tbv pme_tbv
pme_tbv pme 2
8/0/0:21 2 0 2 unavailable OFF DOWN pme_tbv pme_tbv
pme_tbv pme 2
8/0/0:22 3 0 3 unavailable OFF DOWN pme_tbv pme_tbv
pme_tbv pme 2
8/0/0:23 4 0 4 unavailable OFF DOWN pme_tbv pme_tbv
pme_tbv pme 2
8/0/0:24 5 0 5 unavailable OFF DOWN pme_tbv pme_tbv
pme_tbv pme 0

```

- a) If the RF output of the controller is shut, you must unshut the port. This action changes the status as ON for the corresponding QAMs. You can verify the state using the **show cable video integrated-cable** command.

```
Router#show cable video integrated-cable 8/0/0
```

```

Integrated TSID ONID Output Physical Admin Operational Virtual-Carrier
Service-Distribution Logical-Edge Encryption Total
Cable Port QAM ID State State -Group Name -Group Name
-Device Name Capable Sessions
-----
8/0/0:20 1 0 1 48 ON UP pme_tbv pme_tbv
pme_tbv pme 2
8/0/0:21 2 0 2 49 ON UP pme_tbv pme_tbv
pme_tbv pme 2
8/0/0:22 3 0 3 50 ON UP pme_tbv pme_tbv
pme_tbv pme 2
8/0/0:23 4 0 4 51 ON UP pme_tbv pme_tbv
pme_tbv pme 2
8/0/0:24 5 0 5 24 ON UP pme_tbv pme_tbv
pme_tbv pme 2

```

Step 3 Verify the JIB channel number for a specific QAM channel using the **show cable video integrated-cable** command.

```
Router#show controllers integrated-Cable 7/0/0 rf-channel 21 verbose
```

```

Chan State Admin Frequency Type Annex Mod srates Interleaver dcid power output
21 UP UP 219000000 VIDEO B 256 5361 I32-J4 - 34 NORMAL
Qam profile: 1
Spectrum Inversion: Off
Frequency Lane: 1 Block: 3 index: 6
Resource status: OK
License: granted <01:07:01 EDT Feb 19 2016>

```

```

QAM Replication:
  Group ID: 57344 (Pilot)
  Slot group ID: 0
  Members: 7/0/0:21 (P) 7/0/1:21 7/0/2:21 7/0/3:21

Channel Replication Status: Up
JIB channel number: 21
Chan Pr EnqQ Pipe RAF SyncTmr Vid Mac Video Primary DqQ TM Mpts Sniff
21 -- 21 0 6880 0 1 0000.0000.0000 1 0 21 0 5 NO 86
Grp Prio P Prate Phy0-ctl Phyl-ctl Enable Tun-Id L2TPv3_Ses_id
2 0 0 1 1 0 TRUE 0 2
Chan Qos-Hi Qos-Lo Med-Hi Med-Lo Low-Hi Low-Lo
21 32774 16384 32768 16384 65536 32768
Chan Med Low TB-neg Qos_Exc Med_Xof Low_Xof Qdrops(H-M-L) Pos Qlen(Hi-Med-lo) Fl
21 0 0 0 0 0 0 0 0 0 N 23808 0 11656 0
DSPHY Register Local Copy: QPRHI = c0005564, QPRLO = 216ab0
DSPHY Register Local Copy Vaddr = 800002e4, qam2max_mapping = 80000015
DSPHY Register Local Copy: SPR ID = 15, SPR Mapping= c200000b
Last read from HW: Fri Feb 19 01:07:57 2016
QPRHI = c0005564, QPRLO = 216ab0, SPR = c200000b SPRMAPING c0000205 Q2Max 80000015
Last time read spr rate info from HW: Fri Feb 19 03:06:43 2016
SPR ID 21, rate value in kbps 3463, overflow count 0, underflow count 0

```

Output Status is Idle or Pending

Procedure

- Step 1** Verify the video traffic. In the below example, the input bitrate is zero, and the input state is IDLE / OFF. These values confirm that there is no input traffic.

```

Router#sh cable video session logical-edge-device id 1
Total Sessions = 6

```

Session Id	Output Encrypt	Streaming Encrypt	Session Type	Destination	UDP Port	Output Program	Input State	Output State	Input Bitrate	Output Bitrate	
1048588	1	Remap	UDP	172.16.0.1	49152	32	IDLE	PENDING	0	0	PME
		Pending		bago_tbv.1.0.1.20.49152							
1048589	1	Remap	UDP	172.16.0.1	49153	33	IDLE	PENDING	0	0	PME
		Pending		bago_tbv.1.0.1.20.49153							
1048590	2	Remap	UDP	172.16.0.1	49154	34	IDLE	PENDING	0	0	PME
		Pending		bago_tbv.1.0.1.21.49154							
1048591	2	Remap	UDP	172.16.0.1	49155	35	IDLE	PENDING	0	0	PME
		Pending		bago_tbv.1.0.1.21.49155							
1048592	3	Remap	UDP	172.16.0.1	49156	36	IDLE	PENDING	0	0	PME
		Pending		bago_tbv.1.0.1.22.49156							
1048593	3	Remap	UDP	172.16.0.1	49157	37	IDLE	PENDING	0	0	PME
		Pending		bago_tbv.1.0.1.22.49157							

- Step 2** Verify details of the video traffic over the mid plane interface through which traffic is routed to the video data plane on the line card. The mid plane is specific to the line-card slot. On subsequent trials, the output packet count should keep increasing. You can verify the output packet count using the **show interfaces video** command.

```
Router#show interfaces video 7/0/0 accounting
```

```
Video7/0/0
          Protocol    Pkts In   Chars In   Pkts Out   Chars Out
          IP          0         0         2211315936 2653579123200
          DEC MOP     0         0          12         756
          ARP         0         0          4         112

Video7/0/0
          Protocol    Pkts In   Chars In   Pkts Out   Chars Out
          IP          0         0         2220252160 2664302592000
          DEC MOP     0         0          12         756
          ARP         0         0          4         112
```

Step 3 If the packet count is not increasing, verify the 10 GigE physical interface through which the video traffic is fed to the chassis using the **show interfaces** command. In the below example, the video traffic is fed through the 10GigE interface 4/1/0 and the counter for packets keeps incrementing.

```
Router#show interfaces tenGigabitEthernet 4/1/0 accounting
TenGigabitEthernet4/1/0
          Protocol    Pkts In   Chars In   Pkts Out   Chars Out
          Other       15        1155       1814       109078
          IP 8038262210 9404766785700 0          0
          DEC MOP     15        1155       14         1078
          ARP         0         0          1          60

Router#show interfaces tenGigabitEthernet 4/1/0 accounting
TenGigabitEthernet4/1/0
          Protocol    Pkts In   Chars In   Pkts Out   Chars Out
          Other       15        1155       1816       109198
          IP 8047199112 9415222959870 0          0
          DEC MOP     15        1155       14         1078
          ARP         0         0          1          60
```

Input State is Active and not Active PSI

If the input state is Active and the input PSI information is not detected, verify the input PMT information section for this particular session.

Procedure

Verify the details of a particular video session, using the **show cable video session logical-edge-device id led-id session-id id** command.

```
Router#show cable video session logical-edge-device id 1 session-id 1048599
Session Name      : bago_tbv.1.0.1.22.49157
Session Id:       : 1048599
Creation Time:    : Thu Feb 18 18:21:25 2016

Output Port      : 3
TSID             : 3
ONID            : 0
Number of Sources : 1
  Destination IP : 172.16.0.1
  UDP Port       : 49157
Config Bitrate   : 2000000
```

```

Jitter                : 150 ms
Processing Type       : Remap
Stream Rate          : CBR
Program Number       : 37
Idle Timeout         : 250 msec
Init Timeout         : 1000 msec
Off Timeout          : 60 sec
Encryption Type      : PME
Encryption Status    : Encrypted

Input Session Stats:
=====
State: ACTIVE-PSI, Uptime: 0 days 00:01:01
IP Packets: In 12202, RTP 0, Drop 0
TP Packets: In 69979, PCR 2447, PSI 1323, Null 3233, Unreference 153
Errors: Discontinuity 8, Sync loss 0, CC error 0, PCR Jump 17,
        Underflow 0, Overflow 0, Block 0
Bitrate: Measured 1716626 bps, PCR 1800140 bps

Output Session Stats:
=====
State: ON, Uptime: 0 days 00:01:01
TP Packets: In 70535, PCR 2440, PSI 1320,
        Drop 910, Forward 68305, Insert 1752
Errors: Info Overrun 0, Info Error 0, Block 0, Overdue 0,
        Invalid Rate 0, Underflow 0, Overflow 0
Bitrate: Measured 1723591 bps

PAT Info:
=====
Version 0, TSID 1, len 20, section 0/0
Program 0: NIT 16
Program 1: PMT 8020

Input PMT Info:
=====
Program 1, Version 0, PCR 8000, Info len 0
PID 8000: Type 2, Info len 5, (desc 2 len 3)
PID 8001: Type 129, Info len 17, (lang eng), (desc 5 len 4), (desc 129 len 3)

Output PMT Info:
=====
Program 37, Version 1, PCR 273, Info len 6, (CA SYS-ID 18249, PID 303)
PID 273: Type 2, Info len 5, (desc 2 len 3)
PID 274: Type 129, Info len 17, (lang eng), (desc 5 len 4), (desc 129 len 3)

Output PID Map:
=====
PID 8000 -> 273
PID 8001 -> 274
PID 8020 -> 272

```

Abnormalities on the Output

If there are any abnormalities in the output such as macro blocks, ans so on, verify if there are any issues such as CC errors or PCR errors in the MPEG packet.

Verify the session details, using the **show cable video session logical-edge-device id led-id session-id id** command. This command displays errors for both input session stats and output session stats.

Configuring CEM Connectivity for PME Encryption

This section explains how to configure the connectivity to the external CEM and enforce PME encryption on the line card.

Only one device from the MSO site can communicate with the Encryption Renewal System (ERS) and obtain the latest ECM templates. The CEM communicates with the ERS and sends the ECM templates to the Cisco Edge QAM devices in the MSO site.

You can configure the following:

- VODS-ID—IDs assigned by CCAD/ARRIS to the MSO site. The configured VODS-ID on the Cisco cBR-8 and the CEM must be same.
- CEM IP—Interface IP of the Windows/Linux system through which the CEM can be reached by Cisco cBR-8.
- CEM Port—Port number on which the CEM listens for connections from the Cisco cBR-8.
- Management Interface—Source IP address of the cBR-8 virtual interface through which the connection must be established with the CEM server.



Note

There can be only one entry for VODS-ID, CEM IP, CEM Port, and Management Interface IP. If you configure any new values for these parameters, the previous configuration is cleared. You can clear the configurations using the 'no' form of the command.

Configuring VODS-ID

To configure the VODS-ID of the CEM, perform the following steps:

```
enable
configure terminal
cable video
encryption
pme vodsid id
exit
```

Configuring CEM IP and Port

To configure the CEM IP and port of the CEM, perform the following steps:

```
enable
configure terminal
cable video
encryption
pme cem ip-address tcp_port
exit
```

Configuring Management IP

To configure the PME management IP address to establish CEM connection, perform the following steps:

The virtual port group must be configured before configuring the management IP. For more information, see the [Configuring the VirtualPortGroup Interface](#) section.

```
enable
configure terminal
cable video
encryption
pme mgmt-ip ip-address
exit
```

Verifying CEM Connectivity

To verify the connection status of PME, use the **show cable video encryption pme status** command as shown in the following example:

```
Router#show cable video encryption pme status
PME Connection Status:
VODS-ID : 111
CEM IP : 1.200.1.163
CEM Port : 5000
Local Mgmt IP : 1.24.2.6
Local Port : 50394
CEM Connection State : Connected
Count of ECMS recd : 2
```

Troubleshooting Tips

Connectivity with CEM is Lost

Procedure

- Step 1** If the CEM connection status is Not Connected, verify the VODS-ID, CEM IP, CEM port and local Mgmt IP address parameters using the **show cable video encryption pme status** command.

```
Router#show cable video encryption pme status
PME Connection Status:
=====
VODS-ID           : 111
CEM IP            : 1.200.1.163
CEM Port          : 5000
Local Mgmt IP     : 1.35.2.5
Local Port        : 0
CEM Connection State : Not Connected
```

- Step 2** If the PME connection parameters are valid, ensure there is route from the Cisco cBR-8's Virtual management iinterface to the CEM by using the **ping** command. Ping the CEM IP address from the virtualPortGroup 0 on which the management IP is created.

```
Router#ping 1.200.1.163 source virtualPortGroup 0
Type escape sequence to abort.
Sending 5, 100-byte ICMP Echos to 1.200.1.163, timeout is 2 seconds:
Packet sent with a source address of 1.35.2.1
```

```
!!!!
Success rate is 100 percent (5/5), round-trip min/avg/max = 1/1/1 ms
```

Step 3 Verify the alarms in the logs for any connectivity loss.

```
Feb 18 18:28:12.053 IST: %VEMAN-3-CEM_CONNECTION_LOST: CLC4: sup_veman: Alarm Set: CEM
Connection Lost: Connection closed by peer-1.200.1.163:5000
```

How to Configure VPME Encryption

Enforcing Data Stream Encryption Type

Before You Begin

Configure the Virtual Carrier Group (VCG) to setup an encrypted session. For more details, see *Configuring Virtual Carrier Group* section.

To configure the encryption type for a VOD session, perform the following steps:

```
enable
configure terminal
cable video
encryption
linecard slot/bay ca-system [dwb | pme | powerkey] scrambler scrambler-type
[dwb-csa | des | dvs042]
exit
```

Configuring Virtual Carrier Group

To configure the Virtual Carrier Group (VCG) for setting up an encrypted session, perform the following steps:

```
enable
configure terminal
cable video
encryption
virtual-carrier-group name[idnumber]
rf-channel start-channel number-end-channel number tsid start-tsid-end-tsid
output-port-number start-num-end-num
virtual-edge-input ipaddr input-port-number port-number
encrypt
exit
```

Verifying VPME Encryption Configuration

- To verify the encryption configurations, use the **show cable video encryption linecard** *[all | slot number]* command as shown in the following example:

```
Router#show cable video encryption linecard 7/0
Line card: 7/0
CA System Scrambler
=====
PME dvs-042
```

- To verify the encryption status of all sessions on an LED, use the **show cable video session logical-edge-device id id** command as shown in the following example:

```
Router#show cable video session logical-edge-device id 1
Total Sessions = 6
```

Session Output Output Id Bitrate	Output Encrypt Port Type	Streaming Encrypt Type Status	Session Session Type Name	Destination UDP Port	Output Program	Input State	Output State	Input Bitrate	
1048582	1	Remap	UDP	172.16.0.1	49152	32	ACTIVE-PSI	ON	996413
981109	PME	Encrypted	bago_tbv.1.0.1.20.49152						
1048583	1	Remap	UDP	172.16.0.1	49153	33	ACTIVE-PSI	ON	1004787
981246	PME	Encrypted	bago_tbv.1.0.1.20.49153						
1048584	2	Remap	UDP	172.16.0.1	49154	34	ACTIVE-PSI	ON	995088
984011	PME	Encrypted	bago_tbv.1.0.1.21.49154						
1048585	2	Remap	UDP	172.16.0.1	49155	35	ACTIVE-PSI	ON	993061
984051	PME	Encrypted	bago_tbv.1.0.1.21.49155						
1048586	3	Remap	UDP	172.16.0.1	49156	36	ACTIVE-PSI	ON	994238
988617	PME	Encrypted	bago_tbv.1.0.1.22.49156						
1048587	3	Remap	UDP	172.16.0.1	49157	37	ACTIVE-PSI	ON	1004658
988602	PME	Encrypted	bago_tbv.1.0.1.22.49157						

- To verify the various sessions, which use the PME modules that are loaded on a specific line-card, use the **show cable video encryption pme linecard slot/bay session 1-65535 | all | summary** command as shown in the example below:

```
Router#show cable video encryption pme linecard 7/0 session all
Count of ECMG Streams: 4
===== ECMG Stream DATA =====
Stream
ID num EcmId CP# CwE CPDur NomCPD EcmRqst EcmRsp
-----
0020(0032) 0020(0032) 0002 0 0 40000 7 2
0021(0033) 0021(0033) 0002 0 0 40000 7 2
0040(0064) 0040(0064) 0002 0 0 40000 7 2
0041(0065) 0041(0065) 0002 0 0 40000 7 2
```

```
Router#show cable video encryption pme linecard 7/0 session 32
Stream 32, session 7681 is active
Stream number = 32 Session number = 7681
ECM requests = 8 ECM replies = 2
ECM ID = 32 CryptoPeriod num = 2
CP duration = 0 Nominal duration = 40000
CA transfer mode = 1 Stream status = No
Error Blob details
```

```
Router#show cable video encryption pme linecard 7/0 session summary
Currently active streams:
Active = 4
ECM req/resp mismatch = 4
```

```

ECM req, all streams = 32
ECM resp, all streams = 8
Since last reset:
Sessions created = 4
Sessions deleted = 0
ECMs received =2
ECMs discarded = 0

```

Troubleshooting Tips

No PMT at the Output

Procedure

- Step 1** Verify the encryption status using the **show cable video session logical-edge-device id** command. If the encrypt status is shown as ca-waiting, then PMT is withheld.

```

Router#show cable video session logical-edge-device id 1
Total Sessions = 6

Session Output Streaming Session Destination UDP   Output  Input      Output Input  Output
Encrypt Encrypt  Session  Destination UDP   Program State      State  Bitrate Bitrate
Id      Port  Type     Type          Port                               State  Bitrate Bitrate
Type   Status  Name
-----
1048582 1      Remap    UDP           172.16.0.1 49152 32      ACTIVE-PSI PENDING 996413 981109
PME     ca-waiting bago_tbv.1.0.1.20.49152

```

- Step 2** Verify if the ECM count is zero using the **show cable video encryption pme status** command.

```

Router#show cable video encryption pme status
PME Connection Status:
VODS-ID : 111
CEM IP : 1.200.1.163
CEM Port : 5000
Local Mgmt IP : 1.24.2.6
Local Port : 50394
CEM Connection State : Connected
Count of ECMs recd : 0

```

- Step 3** Verify if the ECM request or response count is 0 using the **show cable video encryption pme linecard slot/bay session summary** command.

```

Router#show cable video encryption pme linecard 7/0 session summary
Currently active streams:
Active = 4
ECM req/resp mismatch = 4
ECM req, all streams = 32
ECM resp, all streams = 8
Since last reset:
Sessions created = 4
Sessions deleted = 0
ECMs received =2

```

```
ECMs discarded = 0
```

Configuration Examples For VPME Encryption

The following example shows running output for a PME configuration:

```
cable video

mgmt-intf virtualPortGroup 0

virtual-carrier-group pme_tbv
encrypt
service-type narrowcast
rf-channel 20-24 tsid 1-5 out 1-5

service-distribution-group pme_tbv
rf-port integrated-cable 7/0/0

bind-vcg
vcg pme_tbv sdg pme_tbv

encryption
linecard 7/0 ca-system pme scrambler dvs
pme vodsid 111
pme cem 1.200.1.163 5000
pme mgmt-ip 1.25.2.6

logical-edge-device pme_tbv
protocol table-based
virtual-edge-input-ip 174.101.1.1 input 1
vcg pme_tbv
active

table-based
vcg vcg_replication
rf-channel 21-31
session pme_tbv1 in 1 start-udp-port 49152 num-sessions-per-qam 2 processing-type remap
start-program 32 jitter 150 cbr
session pme_tbv2 in 1 start-udp-port 50001 num-sessions-per-qam 2 processing-type remap
start-program 64 jitter 150 cbr
```

Use Cases or Deployment Scenarios

Topology

A typical topology for CEM connectivity is shown below:

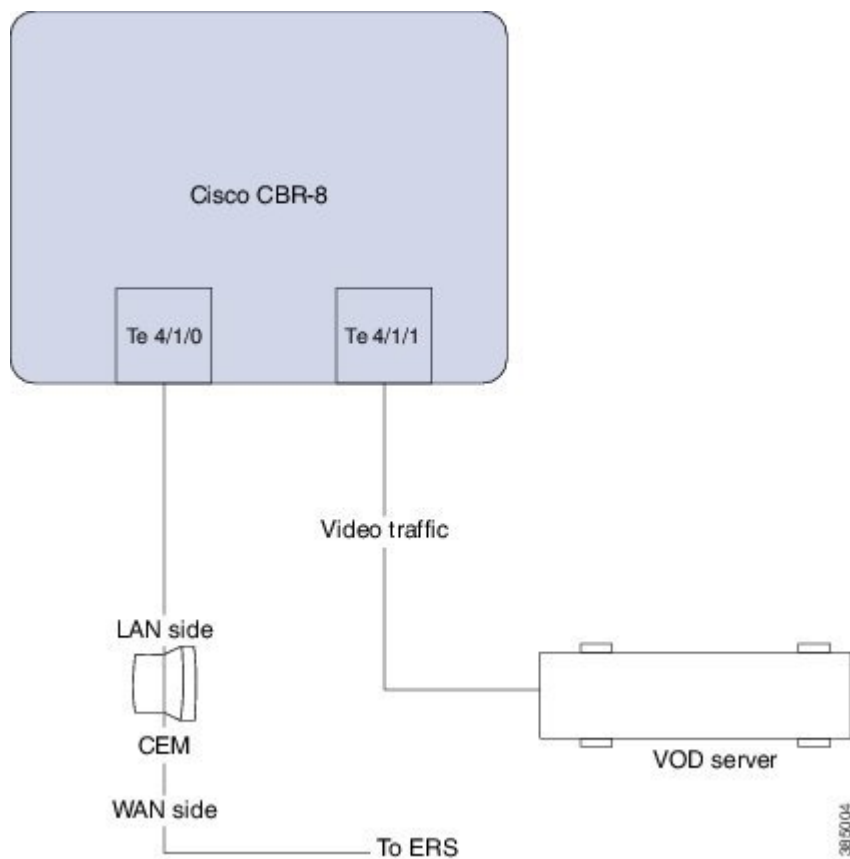

Feature Information for Table-Based Video and VPME Encryption

Table 16: Feature Information for Table-Based Video and VPME Encryption

Feature Name	Releases	Feature Information
Table-Based Video and VPME Encryption	Cisco IOS XE Everest 16.5.1	This feature was integrated on the Cisco cBR Series Converged Broadband Routers.



CHAPTER 16

PMV Support for Table-Based Videos

The PMV support for table-based videos enables the operators to specify a range of PIDs that can be used for a specific UDP flow. Operators require this feature when they want to know in advance which PIDs are selected for a specific UDP flow. .

Contents

- [Information About the PMV Support for Table-Based Videos, on page 89](#)
- [How to Configure PMV, on page 91](#)
- [Disabling PMV Allocation Scheme for LED, on page 93](#)
- [Configuration Examples, on page 94](#)
- [Feature Information for PMV Support, on page 97](#)

Information About the PMV Support for Table-Based Videos

This feature is used in deployments, where PID allocations are required and allows the operator to configure fixed PID groups for a specific UDP flow. To avail this feature, the operator can choose a specific group of PIDs using a PID map value. The operators can enable this feature at the LEDs that are configured for table-based video sessions.

Overview of PMV

This feature uses the following PID group allocation scheme for allocating PIDs for table-based session.

$$\text{Start PID} = \text{PID offset} + (\text{PID Map Value} \times 32)$$

The attributes in this scheme are explained in the following table:

Attribute	Description
Start PID	Value of the first PID in this specific PID group.
PID offset	PID value to factor is standard PIDs. The hardcoded value is 48.
PID Map value	Configurable value for selecting a specific PID group. This attribute can take values from 0 to 251.

To enable this feature for a table-based QAM, the operator should specify the following details:

- Whether the operator wants to use this static allocation scheme that is mentioned in this section
- The actual PID group to pick for a session (PMV)

The PMV is assigned per UDP flow. When a configuration entry with a UDP range is created, the PMV value automatically increments by 1 from the PMV entry corresponding to the first UDP port.

When PMV = 0, PMT PID = $48 + (0 \times 32) = 48$, the elementary stream PIDs take the values from 49 to 79.

When PMV = 1, PMT PID = $48 + (1 \times 32) = 80$, the elementary stream PIDs take the values from 81 to 111.

The following table provides an overview of how PMVs are related to the selected PIDs.

PMV	0	1	...	251
PMT	48	80	...	8080
ES PID 1	49	81	...	8081
ES PID 2	50	82	...	8082
...
ES PID 31	79	111	...	8111

Prerequisites for Configuring PMV

PMV is applicable only for table-based video sessions. The following prerequisites are applicable for configuring PMV for the sessions.

- Service Distribution Group (SDG)
- Virtual Carrier Group (VCG)
- Bind VCG to SDG
- Logical Edge Device (LED)
- Protocol of LED specified as table-based
- Associate VCG to LED

Restrictions for Configuring PMV

The following restrictions are applicable for configuring PMV for the sessions:

- This feature is applicable only to the table-based sessions.
- The PMV feature applies only to SPTS remap sessions, because the MPTS sessions always use pass-through mode.

- After you configure PMV, it affects only the PID group allocation scheme and does not affect the PID allocation scheme inside a PID group.
- This allocation scheme is specified at the LED level and is optional. If not specified, the system uses the default LRU-based scheme.
- If the operator reserves a PID range after the PMV allocates a PID group, it will be handled similarly to that of the existing Least Recently Used (LRU) allocation scheme.

How to Configure PMV

To configure PMV, do the following tasks:

- Enable the PMV allocation scheme in the LED protocol configuration
- Configure the PMV for a session in the RF channel

Enabling PMV Allocation Scheme for LED

Before You Begin

- Identify the LED for which you want to enable the PMV
- Make sure that the LED protocol is set to table-based



Note If table-based video sessions are already present on VCGs that are bound to the LEDs, enabling PMV removes these sessions. Later, you must reconfigure them with the specified PMV values.

Procedure

To enable the PMV allocation scheme for LED, follow this procedure:

```
Router>enable
Router#configure terminal
Router(config)#cable video
Router(config-video)#logical-edge-device led_tbv id 1
Router(config-video-led)#protocol table-based
Router(config-video-led-protocol)#pmv
%%All sessions configured for this LED will be removed.
Enable PMV? [Yes/No] [confirm] Y
Router(config-video-led-protocol)#
```

Verifying the PMV Configuration on LED

To verify that you have enabled the PMV for an LED, run the **show running-config** command as provided in the following example:

```
Router# show running-config | s cable video
cable video
  mgmt-intf VirtualPortGroup 0
```

```

service-distribution-group sdg_tbv id 1
  rf-port integrated-cable 7/0/0
service-distribution-group sdg_tbv1 id 2
  rf-port integrated-cable 7/0/1
virtual-carrier-group vcg_tbv id 1
  service-type narrowcast
  rf-channel 0-95 tsid 1-96 output-port-number 1-96
virtual-carrier-group vcg_tbv1 id 2
  service-type narrowcast
  rf-channel 0-95 tsid 97-192 output-port-number 97-192
bind-vcg
  vcg vcg_tbv sdg sdg_tbv
  vcg vcg_tbv1 sdg sdg_tbv1
logical-edge-device led_tbv id 1
  protocol table-based
  virtual-edge-input-ip 174.101.1.1 input-port-number 1
  vcg vcg_tbv
  vcg vcg_tbv1
  pmv
  active

```

How to Configure Sessions with PMV Value

Each session in an RF channel can have a PMV value in the range of 0 to 251.

Before You Begin

- Identify the VCG and RF channel for which you want to create sessions

Make sure that the LED that VCG is part has PMV enabled

Procedure

To configure an RF channel session with the PMV value, follow this procedure:

```

Router>enable
Router#configure terminal
Router(config)#cable video
Router(config-video)#logical-edge-device led_tbv id 1
Router(config-video-led)#protocol table-based
Router(config-video-led-protocol)#virtual-edge-input-ip 174.101.1.1 input-port-number 1
Router(config-video-led-protocol)#vcg vcg_tbv
Router(config-video-led-protocol)#vcg vcg_tbv1
Router(config-video-led-protocol)#pmv
Router(config-video-led-protocol)#active
Router(config-video-led-protocol)#table-based
Router(config-video-tb)#vcg vcg_tbv
Router(config-video-tb-vcg)#rf-channel 0
Router(config-video-tb-vcg-sess)#session session1 input-port 1 start-udp-port 30000
processing-type remap start-program 20 start-pmv 0 cbr

Router(config-video-tb-vcg-sess)#rf-channel 1
Router(config-video-tb-vcg-sess)#session session_group1 input-port 1 start-udp-port 6000
num-sessions-per-qam 15 processing-type remap start-program 40 start-pmv 0 cbr

Router(config-video-tb-vcg-sess)#session session_group2 input-port 1 start-udp-port 8000
num-sessions-per-qam 10 processing-type remap start-program 80 start-pmv 30 cbr
Router(config-video-tb-vcg-sess)#

```

Verifying the PMV on RF Channel Sessions

To verify the PMV configuration on an RF channel session, run the **show cable video session** command as provided in the following example:

```
Router# show cable video session logical-edge-device id 1
```

Troubleshooting Tips

When configuring RF channel sessions, if you configure the same PMV value for two or more sessions of the same RF channel, an error appears and the CLI command is rejected.

If you have to configure a reserved PID range, configure it before assigning the PMV values to the sessions. This process enables Cisco cBR-8 Series Router to reject the session configuration. It also shows a warning message to the operator when configuring those sessions with the PMV value that can allocate PIDs in the reserve PID range.

If PMV is enabled for an LED, when configuring sessions for RF channels that are part of the LED, without the *start-pmv* value, Cisco cBR-8 Series Router uses the default PMV value of 0.

Disabling PMV Allocation Scheme for LED

Before You Begin

- Identify the LED for which you want to disable the PMV
- If table-based sessions are already present on VCGs that are bound to the LEDs, disabling the PMV removes these sessions. Later, reconfigure them without the PMV values.

Procedure

To disable the PMV allocation scheme for LED, follow this procedure:

```
Router>enable
Router#configure terminal
Router(config)#cable video
Router(config-video)#logical-edge-device led_tbv id 1
Router(config-video-led)#protocol table-based
Router(config-video-led-protocol)#no pmv
%%All sessions configured for this LED will be removed.
Disable PMV? [Yes/No] [confirm] Y
Router(config-video-led-protocol)#
```

Verifying the Disabled PMV Configuration

To verify whether the PMV configuration is disabled on an LED, run the **show running-config | s cable video** command as provided in the following example:

```
Router# show running-config | s cable video

cable video
  mgmt-intf VirtualPortGroup 0
  service-distribution-group sdg_tbv id 1
  rf-port integrated-cable 7/0/0
```

```

service-distribution-group sdg_tbv1 id 2
  rf-port integrated-cable 7/0/1
virtual-carrier-group vcg_tbv id 1
  service-type narrowcast
  rf-channel 0-95 tsid 1-96 output-port-number 1-96
virtual-carrier-group vcg_tbv1 id 2
  service-type narrowcast
  rf-channel 0-95 tsid 97-192 output-port-number 97-192
bind-vcg
  vcg vcg_tbv sdg sdg_tbv
  vcg vcg_tbv1 sdg sdg_tbv1
logical-edge-device led_tbv id 1
  protocol table-based
  virtual-edge-input-ip 174.101.1.1 input-port-number 1
  vcg vcg_tbv
  vcg vcg_tbv1
  active

```

Configuration Examples

This section provides examples for configuring PMV on table-based video.

Example 1: Assigning PMV to a Session on a Single RF Channel

```

Router#configure terminal
Enter configuration commands, one per line. End with CNTL/Z.
Router(config)#cable video
Router(config-video)#mgmt-intf VirtualPortGroup 0
Router(config-video)#service-distribution-group sdg-1 id 1
Router(config-video-sdg)#rf-port integrated-cable 8/0/0
Router(config-video-sdg)#service-distribution-group sdg-2 id 2
Router(config-video-sdg)#rf-port integrated-cable 8/0/1
Router(config-video-sdg)#virtual-carrier-group vcg-1 id 1
Router(config-video-vcg)#encrypt
Router(config-video-vcg)#service-type narrowcast
Router(config-video-vcg)#rf-channel 20 tsid 1-21 output-port-number 1-21
Router(config-video-vcg)#virtual-carrier-group vcg-2 id 2
Router(config-video-vcg)#encrypt
Router(config-video-vcg)#service-type narrowcast
Router(config-video-vcg)#rf-channel 20 tsid 22-42 output-port-number 22-42
Router(config-video-vcg)#bind-vcg
Router(config-video-bd)#vcg vcg-1 sdg sdg-1
Router(config-video-bd)#vcg vcg-2 sdg sdg-2
Router(config-video-bd)#logical-edge-device led1 id 1
Router(config-video-led)#protocol table-based
Router(config-video-led-protocol)#virtual-edge-input-ip 174.101.1.1 input-port-number 1
Router(config-video-led-protocol)#vcg vcg-1
Router(config-video-led-protocol)#vcg vcg-2
Router(config-video-led-protocol)#pmv
%%All sessions configured for this LED will be removed.
Enable PMV? [Yes/No] [confirm]Y
Router(config-video-led-protocol)#active
Router(config-video-led-protocol)#table-based
Router(config-video-tb)#vcg vcg-1
Router(config-video-tb-vcg)#rf-channel 20
Router(config-video-tb-vcg-sess)#session TBV70 input-port 1 start-udp-port 49153
processing-type remap start-program 7001 start-pmv 230 bit-rate 2000000
Router(config-video-tb-vcg)#vcg vcg-2
Router(config-video-tb-vcg)#rf-channel 20
Router(config-video-tb-vcg-sess)#session TBV_VCG2 input-port 1 start-udp-port 50153
num-sessions-per-qam 15 processing-type remap start-program 7001 start-pmv 230 bit-rate

```

```
2000000
Router(config-video-tb-vcg) #
```

Example 2: Assigning PMV to Sessions for Multiple RF Channels in a VCG

```
Router>enable
Router#configure terminal
Enter configuration commands, one per line. End with CNTL/Z.
Router(config)#cable video
Router(config-video)#mgmt-intf VirtualPortGroup 0
Router(config-video)#encryption
Router(config-video-encrypt)#linecard 8/0 ca-system powerkey scrambler des
%WARNING: Linecard has to be reloaded for scrambling to work.

%WARNING: Standby linecard 7 has to be reloaded for video redundancy to work properly.

Router(config-video-encrypt-dvb-conf)#service-distribution-group sdg1 id 1
Router(config-video-sdg)#onid 100
Router(config-video-sdg)#rf-port integrated-cable 8/0/0
Router(config-video-sdg)#service-distribution-group sdg2 id 2
Router(config-video-sdg)#onid 200
Router(config-video-sdg)#rf-port integrated-cable 8/0/1
Router(config-video-sdg)#service-distribution-group sdg3 id 3
Router(config-video-sdg)#onid 300
Router(config-video-sdg)#rf-port integrated-cable 8/0/2
Router(config-video-sdg)#service-distribution-group sdg4 id 4
Router(config-video-sdg)#onid 400
Router(config-video-sdg)#rf-port integrated-cable 8/0/3
Router(config-video-sdg)#service-distribution-group sdg5 id 5
Router(config-video-sdg)#onid 500
Router(config-video-sdg)#rf-port integrated-cable 8/0/4
Router(config-video-sdg)#service-distribution-group sdg6 id 6
Router(config-video-sdg)#onid 600
Router(config-video-sdg)#rf-port integrated-cable 8/0/5
Router(config-video-sdg)#service-distribution-group sdg7 id 7
Router(config-video-sdg)#onid 700
Router(config-video-sdg)#rf-port integrated-cable 8/0/6
Router(config-video-sdg)#service-distribution-group sdg8 id 8
Router(config-video-sdg)#onid 800
Router(config-video-sdg)#rf-port integrated-cable 8/0/7
Router(config-video-sdg)#service-distribution-group sdg1dup id 9
Router(config-video-sdg)#onid 900
Router(config-video-sdg)#rf-port integrated-cable 8/0/0
Router(config-video-sdg)#virtual-carrier-group vcg1 id 1
Router(config-video-vcg)#encrypt
Router(config-video-vcg)#service-type narrowcast
Router(config-video-vcg)#rf-channel 0-55 tsid 1-56 output-port-number 1-56
Router(config-video-vcg)#virtual-carrier-group vcg2 id 2
Router(config-video-vcg)#encrypt
Router(config-video-vcg)#service-type narrowcast
Router(config-video-vcg)#rf-channel 0-55 tsid 57-112 output-port-number 57-112
Router(config-video-vcg)#virtual-carrier-group vcg3 id 3
Router(config-video-vcg)#encrypt
Router(config-video-vcg)#service-type narrowcast
Router(config-video-vcg)#rf-channel 0-55 tsid 113-168 output-port-number 113-168
Router(config-video-vcg)#virtual-carrier-group vcg4 id 4
Router(config-video-vcg)#encrypt
Router(config-video-vcg)#service-type narrowcast
Router(config-video-vcg)#rf-channel 0-55 tsid 169-224 output-port-number 169-224
Router(config-video-vcg)#virtual-carrier-group vcg5 id 5
Router(config-video-vcg)#encrypt
Router(config-video-vcg)#service-type narrowcast
Router(config-video-vcg)#rf-channel 0-55 tsid 1-56 output-port-number 225-280
Router(config-video-vcg)#virtual-carrier-group vcg6 id 6
```

```

Router(config-video-vcg)#encrypt
Router(config-video-vcg)#service-type narrowcast
Router(config-video-vcg)#rf-channel 0-55 tsid 57-112 output-port-number 281-336
Router(config-video-vcg)#virtual-carrier-group vcg7 id 7
Router(config-video-vcg)#encrypt
Router(config-video-vcg)#service-type narrowcast
Router(config-video-vcg)#rf-channel 0-55 tsid 113-168 output-port-number 337-392
Router(config-video-vcg)#virtual-carrier-group vcg8 id 8
Router(config-video-vcg)#encrypt
Router(config-video-vcg)#service-type narrowcast
Router(config-video-vcg)#rf-channel 0-55 tsid 169-224 output-port-number 393-448
Router(config-video-vcg)#bind-vcg
Router(config-video-bd)#vcg vcg1 sdg sdg1
Router(config-video-bd)#vcg vcg2 sdg sdg2
Router(config-video-bd)#vcg vcg3 sdg sdg3
Router(config-video-bd)#vcg vcg4 sdg sdg4
Router(config-video-bd)#vcg vcg5 sdg sdg5
Router(config-video-bd)#vcg vcg6 sdg sdg6
Router(config-video-bd)#vcg vcg7 sdg sdg7
Router(config-video-bd)#vcg vcg8 sdg sdg8
Router(config-video-bd)#logical-edge-device led1 id 1
Router(config-video-led)#protocol table-based
Router(config-video-led-protocol)#virtual-edge-input-ip 174.102.1.1 input-port-number 2
Router(config-video-led-protocol)#vcg vcg1
Router(config-video-led-protocol)#vcg vcg2
Router(config-video-led-protocol)#active
Router(config-video-led-protocol)#logical-edge-device led2 id 2
Router(config-video-led)#protocol table-based
Router(config-video-led-protocol)#virtual-edge-input-ip 174.101.1.1 input-port-number 1
Router(config-video-led-protocol)#vcg vcg5
Router(config-video-led-protocol)#vcg vcg6
Router(config-video-led-protocol)#vcg vcg7
Router(config-video-led-protocol)#vcg vcg8
Router(config-video-led-protocol)#pmv
%%All sessions configured for this LED will be removed.
Enable PMV? [Yes/No] [confirm]Y
Router(config-video-led-protocol)#active
Router(config-video-led-protocol)#logical-edge-device led3 id 3
Router(config-video-led)#protocol table-based
Router(config-video-led-protocol)#virtual-edge-input-ip 174.103.1.1 input-port-number 3
Router(config-video-led-protocol)#vcg vcg3
Router(config-video-led-protocol)#vcg vcg4
Router(config-video-led-protocol)#active
Router(config-video-tb)#table-based
Router(config-video-tb)#vcg vcg5
Router(config-video-tb-vcg)#rf-channel 0-55
Router(config-video-tb-vcg-sess)#session SESS_TB input-port 1 start-udp-port 50000
num-sessions-per-qam 20 processing-type remap start-program 1 start-pmv 0 bit-rate 1800000
Router(config-video-tb-vcg-sess)#vcg vcg6
Router(config-video-tb-vcg)#rf-channel 0-55
Router(config-video-tb-vcg-sess)#session SESS_TB input-port 1 start-udp-port 52000
num-sessions-per-qam 20 processing-type remap start-program 1 start-pmv 0 bit-rate 1800000
Router(config-video-tb-vcg-sess)#vcg vcg7
Router(config-video-tb-vcg)#rf-channel 0-55
Router(config-video-tb-vcg-sess)#session SESS_TB input-port 1 start-udp-port 54000
num-sessions-per-qam 20 processing-type remap start-program 1 start-pmv 0 bit-rate 1800000
Router(config-video-tb-vcg-sess)#vcg vcg8
Router(config-video-tb-vcg)#rf-channel 0-23
Router(config-video-tb-vcg-sess)#session SESS_TB input-port 1 start-udp-port 56000
num-sessions-per-qam 20 processing-type remap start-program 1 start-pmv 0 bit-rate 1800000
Router(config-video-tb-vcg-sess)#

```

Feature Information for PMV Support

Table 17: Feature Information for PMV Support for Table-Based Videos

Feature Name	Releases	Feature Information
PMV Support for Table-Based Videos	Cisco IOS XE Everest 16.5.1	This feature was integrated on the Cisco cBR Series Converged Broadband Routers.



CHAPTER 17

Video QAM Replication

The Video QAM replication feature allows video carriers to be replicated to support service group alignment between DOCSIS and Video service groups.

Contents

- [QAM Replication, on page 99](#)
- [Information About Replication, on page 99](#)
- [Configuring Replication for Table-Based or Session-Based Video, on page 101](#)
- [Configuration Examples, on page 102](#)
- [Feature Information for Replication, on page 103](#)

QAM Replication

The QAM replication feature allows duplication of content on multiple QAM carriers. This feature is internal to the cBR-8 and replaces the need for external splitters, allowing content to be replicated across multiple ports on a line card.

Information About Replication

- **Multiple Ports:** Multiple ports in a Service Distribution Group (SDG) replicate all QAMs from the Virtual Carrier Group (VCG) to output port listed in the same SDG.
- **Unicast:** Unicast (Video on Demand) services cannot be replicated across line cards.

Overview of QAM Replication

Video on Demand (VoD) or unicast services cannot be replicated across line cards. You can accomplish replication by adding more than one RF port to an SDG. This feature works for the SDG regardless of whether the video sessions are table-based or session-based.

Replication also applies to the QAM PHY parameters. Hence, the QAM PHY parameters like frequency, annex, and symbol rate of the replicated QAM carrier are the same as the QAM PHY parameters on the pilot QAM carrier.

QAM replication is achieved in two ways: software and hardware. The line card performs the hardware QAM replication. Each line card has the capability to replicate an output QAM (Pilot QAM) from one port to another output QAM (Replicate QAM) on another port.



Note QAM replication in the same port is not supported.

The **service-distribution-group** construct is used to perform replication. Hardware replication is supported when the replication of individual QAM Carriers is limited to the same line card.

The **bind-vcg** construct, which is used to determine the physical QAMs to be replicated, is analogous to combiner and splitter combination. The RF ports combine all the QAMs routed to them. Then, one or more inputs are split to one or more RF output ports.

Benefits of QAM Replication

QAM replication reduces the need for external HFC components like splitters and combiners in the RF plant.

The figure below illustrates the bind operation that replaces a combiner and a splitter and performs replication on multiple ports that are assigned to an SDG.

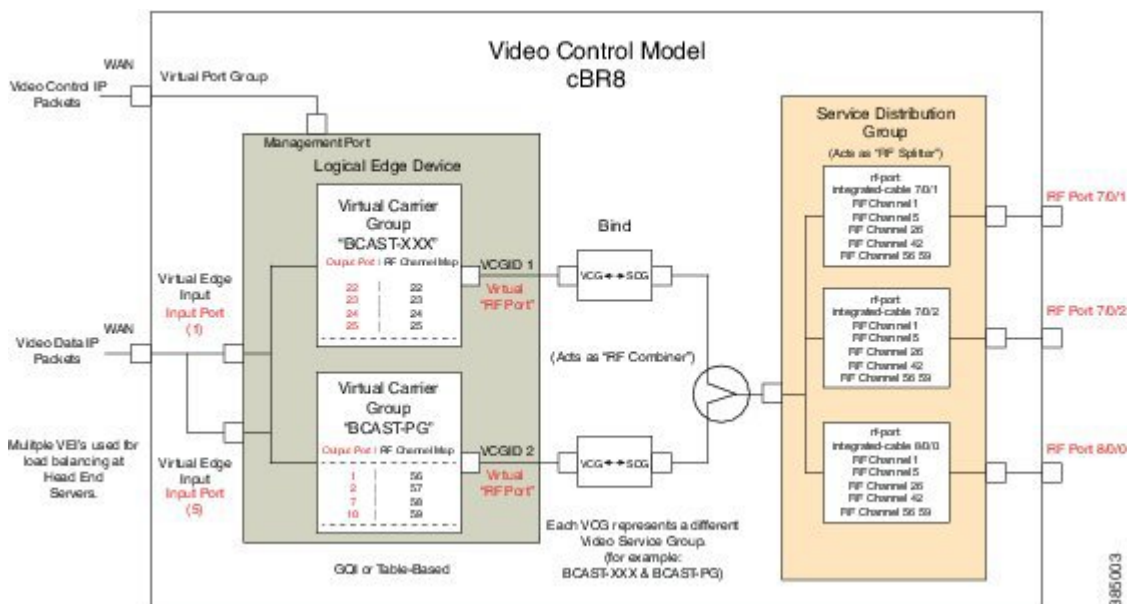

Prerequisites for Replication

The controller type for the slot/bay/port used for the SDG should be set as 'VIDEO'. The errors corresponding to the incorrect controller type used in the SDG appear during the bind operation.

Perform the following steps to set the controller type:

```
configure terminal
controller Integrated-Cable slot/bay/port
rf-channel start-channel - end-channel
type VIDEO
```

```

start-frequency frequency
rf-output normal
power-adjust number
qam-profile qam-profile number

```

Restrictions for QAM Replication

- Hardware can support QAM replication only within the same line card.
- The output of a source QAM in any port can be replicated to only one QAM in another port. Replication within the same port is not supported.
- The current line card has a maximum of eight ports. Hence, for each line card a pilot QAM can have up to seven replicates (one on each port).
- Standard routing protocols prohibit routing of unicast traffic (VOD) to multiple destinations (across line cards).

Configuring Replication for Table-Based or Session-Based Video

Replication is configured within the SDG by adding a set of RF ports to the same SDG. To configure replication you must choose the Pilot QAM carriers, a set of QAM carriers belonging to a RF port. The Pilot QAM carriers are denoted by the first RF port added under SDG. The rest of RF ports, which carry the replicated content, are specified within this SDG.

Choose the QAM carriers, which carry the content to be replicated, by configuring Virtual Carrier Group (VCG) and specifying the number of QAM channels that are replicated in each RF port. When the pilot QAM carrier is removed, one of the remaining replicated QAM carriers is automatically chosen as pilot QAM carrier.

To configure the replication, complete the following procedure:

```

configure terminal
cable video
service-distribution-group service distribution group name
rf-port integrated-cable slot/bay/port
rf-port integrated-cable slot/bay/port
virtual-carrier-group vcg_replication id number
virtual-edge-input-ip ip-address vrf vrf-name input-port-number number
rf-channel n-m tsid n-m output-port-number n-m
bind-vcg
vcg vcg_replication sdg sdg_replication

```

Verifying Replication of Table Based Video Sessions

To verify the replication information including the replication group ID, pilot or replicant, and the associated status, use the **show cable card slot/bayqam-repl group** command as shown in the example below:

```
Router#show cable card 7/0 qam-repl group
```

```

-----
Grp Slot Chan QAM Grp  Chan
ID Grp cnt type State List
ID [port:chan state role]

```

```
U:Up    P:Pilot
D:Down  R:Replicant
```

```
-----
57344 0 4 VID U 0:21 UP 1:21 UR 2:21 UR 3:21 UR
57345 1 4 VID U 0:22 UP 1:22 UR 2:22 UR 3:22 UR
57346 2 4 VID U 0:23 UP 1:23 UR 2:23 UR 3:23 UR
57347 3 4 VID U 0:24 UP 1:24 UR 2:24 UR 3:24 UR
57348 4 4 VID U 0:25 UP 1:25 UR 2:25 UR 3:25 UR
57349 5 4 VID U 0:26 UP 1:26 UR 2:26 UR 3:26 UR
57350 6 4 VID U 0:27 UP 1:27 UR 2:27 UR 3:27 UR
57351 7 4 VID U 0:28 UP 1:28 UR 2:28 UR 3:28 UR
57352 8 4 VID U 0:29 UP 1:29 UR 2:29 UR 3:29 UR
57353 9 4 VID U 0:30 UP 1:30 UR 2:30 UR 3:30 UR
57354 10 4 VID U 0:31 UP 1:31 UR 2:31 UR 3:31 UR
-----
```

```
Total number of Replication groups on slot 7/0: 11
```

To verify the sessions on the pilot QAM carrier, use the **show cable video session logical-edge-device id number** command as shown in the example below:

```
Router#show cable video session logical-edge-device id 1
Total Sessions = 22
```

Session Output Id	Output Input Port	Streaming Output Type	Session Encrypt Type	Destination Encrypt Port	UDP Program	Output State	Input State
Bitrate	Bitrate	Type	Status	Name			
1048598	21	Remap	UDP	172.16.0.1	49152 32	ACTIVE-PSI	ON
1104548	1088424	CLEAR	-	bago_tbv.1.21.49152			
1048599	21	Remap	UDP	172.16.0.1	49153 33	ACTIVE-PSI	ON
1104482	1088424	CLEAR	-	bago_tbv.1.21.49153			
1048600	22	Remap	UDP	172.16.0.1	49154 34	ACTIVE-PSI	ON
1104922	1090656	CLEAR	-	bago_tbv.1.22.49154			
1048601	22	Remap	UDP	172.16.0.1	49155 35	ACTIVE-PSI	ON
1105033	1090534	CLEAR	-	bago_tbv.1.22.49155			
1048602	23	Remap	UDP	172.16.0.1	49156 36	ACTIVE-PSI	ON
1114332	1092488	CLEAR	-	bago_tbv.1.23.49156			
1048603	23	Remap	UDP	172.16.0.1	49157 37	ACTIVE-PSI	ON
1104353	1092488	CLEAR	-				

Configuration Examples

The following example configures replication across four RF ports on line card 7/0:

```
configure terminal
cable video
```

```

service-distribution-group sdg replication id 1
rf-port integrated-cable 7/0/0
rf-port integrated-cable 7/0/1
rf-port integrated-cable 7/0/2
rf-port integrated-cable 7/0/3
virtual-carrier-group vcg_replication id 1
virtual-edge-input-ip 172.31.1.1 vrf vrf-name input-port-number 1
rf-channel 21-31 tsid 21-31 output-port-number 21-31
bind-vcg
vcg vcg_replication sdg sdg_replication

```

Feature Information for Replication

Table 18: Feature Information for Replication

Feature Name	Releases	Feature Information
Replication	Cisco IOS XE Everest 16.5.1	This feature was integrated on the Cisco cBR Series Converged Broadband Routers.



CHAPTER 18

D6 Discovery Protocol

The D6 discovery protocol is part of the Comcast Next Generation on Demand (NGOD) specification. This protocol helps in advertising the video QAM carrier information like frequency, modulation mode, annex, and edge input for the video traffic such as IP address, group name, maximum bandwidth, and so on, to an Edge Resource Manager (ERM). The D6 discovery protocol also sends unique structured names (topological location information) for each edge input or carrier output. From these structured names, and input and RF port numbers, the ERM can infer the topological network location of both the QAM streaming input port (IP) and RF output port (MPEG).

Contents

- [Information About D6 Discovery Protocol, on page 105](#)
- [How to Configure the D6 Discovery Protocol, on page 107](#)
- [Example: D6 Discovery Protocol Configuration, on page 111](#)
- [Deployment Scenario for the D6 Discovery Protocol, on page 112](#)
- [Feature Information for D6 Discovery Protocol, on page 113](#)

Information About D6 Discovery Protocol

The following sections provide more information about the D6 discovery protocol.

Overview of the D6 Discovery Protocol

You should configure the D6 discovery protocol for each Logical Edge Device (LED). When the LED is set to active, the D6 discovery protocol establishes a connection with the ERM and sends out the below information to the ERM:

- **Streaming Zone**—The streaming zone within which the LED operates. You must configure a streaming zone.
- **Component Name**—The name of the LED for the ERM to associate the subsequent update messages. You must configure a component name.
- **Vendor Specific String**—Contains the vendor and mode names. When using PME encryption, the D6 vendor-string must be changed to something other than “Cisco”, for example, vendor-string “CBR8”. For PowerKEY encryption, the vendor-string is an optional configuration and the default value is “Cisco CBR8k”.

Edge inputs are configured under the LED or the Virtual Carrier Groups (VCG) associated to the LEDs. For each edge input, the following information is sent to the ERM:

- IP Address—As configured under LED or VCG associated to the LED.
- Port—As configured for each input port.
- Max Bandwidth—As configured under the input group of D6 configuration. The default value is 20 Gbps.
- Group name—As configured under the input group of D6 configuration. The default value is the LED name if the input port is configured under LED or the VCG name if the input port is configured under VCG

For every QAM (RF channel) configured under the LED through VCG, the following information is sent to the ERM:

- Route—Route state as Reachable, if a QAM is added, Withdrawn, if a QAM is removed.
- QAM Group Name—As configured for the VCG name.
- QAM Name—Streaming zone.tsid (for example, 1234.100). Streaming zone is configured under D6 and TSID is configured under VCG for every QAM.
- Total Bandwidth— Total bandwidth of the QAM.
- QAM Parameters:
 - Frequency—Center frequency of this carrier
 - Interleaver
 - Modulation Mode
 - TSID
 - Annex—A/B
 - Channel Width - 6 MHz/8 MHz
- UDP Map—This is sent only for the table-based session configurations. A table of the UDP port for each MPEG program number is sent out through this.
- Output Port—The configured VCG ID is sent out as the Output Port ID.

The configuration updates are sent to the ERM through different update messages. D6 also exchanges the keep alive messages periodically to retain the TCP connection with the ERM.

Prerequisites for D6 Discovery Protocol

- As the D6 configuration is placed under the LED protocol configuration, you must complete the following configurations before configuring the D6 discovery protocol:
 - Service Distribution Group (SDG)
 - Virtual Carrier Group (VCG)
 - Bind VCG to SDG

- Logical Edge Device (LED)
- Associate VCG to LED
- Since the D6 discovery protocol requires a management IP for communicating with the external server, ensure that the virtual port group interface is configured and the same is set for the management interface under cable video. Follow the procedure below to configure a virtual port group:

```
configure terminal
cable video
mgmt-intf VirtualPortGroup virtual port group id
```

- If you must configure a Fully Qualified Domain Name (FQDN) for the D6 server configuration instead of the IP address, then ensure that you configure the name server before configuring the D6 discovery protocol. Use the **show ip dns view** command to see if the DNS name server is configured. Follow the procedure below to configure the name server:

```
ip name-server ip address
ip domain name domain name
ip domain lookup
```

How to Configure the D6 Discovery Protocol

You can perform the D6 configuration only when the LED protocol is either table-based or GQI.

Configuring the Mandatory D6 Discovery Protocol Parameters

The mandatory D6 configuration parameters are:

- Management IP—The source IP address used to establish connection with the external D6 server (ERM). The IP address must be in the same subnet as configured in a virtual port group. For GQI LED, this configuration is not needed under the D6 discovery protocol as it is automatically fetched from the GQI LED configuration.
- D6 discovery protocol server IP address and port—This is to identify the remote D6 server (ERM) IP address and listening port used by the D6 client in LED to setup connection with the peer. You can configure only one server address and port per LED. There are two ways to setup the IP address, either by directly providing the IP address or by configuring the FQDN. Either one is sufficient for establishing a connection with the server. If you configure both, then the IP address is preferred over the FQDN. Both IP address and FQDN configurations must point to the same server and port.
- Streaming zone—Streaming zone as configured in the D6 server (ERM). The name should match with the one configured in the ERM for the connection to be established.
- Component name—The name of the Edge QAM device. Each LED is considered by the D6 server as a separate Edge QAM component. This name is used by the D6 server to represent the LED.

Before You Begin

Ensure the following:

- Virtual port group interface is configured and a management IP for the D6 discovery protocol is identified (in case of table-based LED).

- Management interface is set to this virtual port group interface under the cable video configuration.
- You have the D6 server IP address or the FQDN, the port value, and the streaming zone name readily available.
- If FQDN is to be used, ensure that the name server is configured and the FQDN is resolving to the IP address by verifying using the **ping <fqdn>** command.
- The LED is configured with either table-based or GQI protocol.
- The LED turns to active without any issue. If errors occur, resolve them first.
- The LED is set to “no active” state.

To configure the D6 discovery protocol for table-based LEDs, complete the following procedure:

```

configure terminal
cable video
logical-edge-device device name [id number]
protocol table-based
no active
discovery-protocol d6
mgmt-ip ip address
streaming-zone name
component-name name
d6-server ip address [port]
d6-server fqdn domain-name [port]
exit
active

```

To configure the D6 discovery protocol for GQI LEDs, complete the following procedure:

```

configure terminal
cable video
logical-edge-device device name [id number]
protocol gqi
no active
discovery-protocol d6
streaming-zone name
component-name name
d6-server ip address [port]
d6-server fqdn domain-name [port]
exit
active

```

Verifying the D6 Discovery Protocol Configurations

To verify the D6 discovery protocol configuration, use the **show cable video logical-edge-device** command as shown in the example below.

This CLI command shows the status and statistics of the D6 client associated to the LED. You can view all the configuration and operation status of the D6 client. In the example below, it shows the duration and the number of open, updated, keepalive and notification messages exchanged between the D6 client and the server, in that duration. It also indicates how many unknown or unrecognized messages are received from the server. When the open message count is more than 1, it indicates that the connection is terminated and reconnected.

show cable video logical-edge-device id 1 d6

```

Logical Edge Device: LED_PME
Id: 1
Protocol: Table-based

D6 Summary:
-----
Enabled           : Yes
VREP Version      : 2

D6 State          : Established
Management IP    : 1.21.2.250
Source Port      : 6069
D6 server FQDN   : New_host1.test1
D6 Server IP     : 1.200.1.86
D6 Server Port   : 6069
Hold Time(negotiated): 240
Timeout          : 20
Keep Alive Interval : 80
Streaming Zone   : 3409
Failure Reason   : No Failure
-----

D6 Statistics:
-----
Duration  Dir   Open   Update  KeepAlive Notification Unknown
-----
0         RX    1      0       19       0         0
0         TX    1      17      2        0         0
-----

```

In the above example, the D6 State as “Established” and the Failure Reason as “No Failure” indicates that the D6 configurations are adequate and it is able to establish the connection with the D6 server or the ERM.

The D6 Statistics section of the output describes various messages exchanged between the D6 client and the D6 server in both the directions (Rx means received and Tx means transmitted). There is no update message from the D6 server to the D6 client, so the Update message count in the RX row should always be 0. The notification message is sent in case of error. When the notification is received, the connection is reset. Unknown message count should be 0, any number greater than 0 indicates a packet corruption. Update message is sent for every update. All the edge input IPs are sent in one update message, but there is a separate update message for every QAM in the LED. So, the update message count increases based on the number of QAMs in the LED. KeepAlive messages are exchanged periodically with the interval defined by the "Keep Alive Interval". This Keep Alive Interval is a function of the Hold time configuration, which is one third of the hold time

Troubleshooting the D6 Mandatory Parameters Configuration

- Troubleshooting tips for possible configuration errors:
 - The management IP should be unique and should be in the subnet of the virtual port group.
 - If both, D6 server IP address and FQDN are configured, ensure that the same port value is used for both.
 - Ensure that the proper D6 server IP address or FQDN name is used.
 - If FQDN is used, verify that the name server is configured and the FQDN gets resolved to the correct IP address by issuing the **ping <fqdn>** command.

- Troubleshooting tips when the D6 state remains Idle:
 - The failure reason indicates the type of failure. For most of the failures, the D6 client retries the connection periodically. Check if it recovers after some time.
 - Verify if the streaming zone configuration is matching with the D6 server setting.
 - Verify if the TCP port number configured for the D6 server in Cisco cBR-8 is matching with the listening port of the D6 server or the ERM.
 - Check if you can ping the D6 server IP address from both the sides, that is, from the Cisco cBR-8 to the D6 server and from the D6 server to the Cisco cBR-8. Try to ping the virtual port group IP and the management IP assigned to the LED from the D6 server. If the ping fails, check the routing between the Cisco cBR-8 and the D6 server.
 - Verify if the D6 server is up and running and ready to accept the connection.
 - Verify if the virtual port group interface is up.
 - Verify if the 10 Gb interface through which the management traffic is passing in to the Cisco cBR-8, is up.

Configuring the D6 Discovery Protocol Optional Parameters

The optional D6 discovery protocol configuration parameters are:

- Vendor string—Vendor specific string for the ERM to identify the vendor. Contains the vendor and the model name. The default value is "Cisco CBR8k"
- Timeout value—Time to wait for the connection in socket call. The default value is 10 seconds.
- Hold time value—This value decides the interval of the keepalive message exchange between the client and the server. The default value is 30 seconds.
- Input group—Each virtual edge input (VEI) IP address under the LED can be assigned an input group name and the maximum bandwidth that is used to send traffic to it. Also, each VCG associated to LED can have a group name and bandwidth. D6 protocol uses this name for all the VEI IP addresses under the VCG. This information is used in the D6 messages when advertising the edge inputs to the D6 server. If these parameters are not configured for the group name, then the LED name for VEI IP addresses under the LED or the VCG name for the VEI IP addresses under the VCG is used. For bandwidth, the default value is 20 Gbps.

Repeat this command for each VEI IP address and VCG under the LED.

Before You Begin

- Ensure that the VEI IP addresses are configured under the LED.
- Ensure that the VCGs are associated to the LED.

To configure the D6 discovery protocol optional parameters, complete the following procedure:

```
configure terminal
cable video
logical-edge-device device name [id number]
protocol table-based
```

```

no active
discovery-protocol d6
vendor-string <string>
timeout seconds
holdtime seconds
input-group vcg id <id> group-name <name>[ bandwidth <mbps>]
input-group led vei-ip <ip> group-name <name>[ bandwidth <mbps>]
exit
active

```

Verifying the Hold Time and Timeout Settings

To verify the hold time and timeout settings, use the **show cable video logical-edge-device** command. The output is the same as shown in the [Verifying the D6 Discovery Protocol Configurations, on page 108](#) section. The hold time affects the keepalive interval, so the new value for the keepalive interval should be one third of the hold time. Also, in the D6 statistics section, the keepalive count increases (in the TX row) based on the keepalive interval.

Troubleshooting the D6 Optional Parameters Configuration

These are optional parameters and do not affect the basic functionalities of D6 discovery protocol. Any change in the D6 discovery protocol configuration will result in a reset of the D6 connection and a reconnection with the new values. So, the D6 state will momentarily move to Idle and then back to Established state.

Example: D6 Discovery Protocol Configuration

The following example shows a complete D6 configuration:

```

cable video
  mgmt-intf VirtualPortGroup 0
  encryption
    linecard 7/0 ca-system pme scrambler dvs042
    pme vodsid 111
    pme cem 1.200.1.163 5000
    pme mgmt-ip 1.25.2.6
  service-distribution-group sdg-pme id 1
    rf-port integrated-cable 7/0/7
  virtual-carrier-group vcg-pme id 1
    encrypt
    service-type narrowcast
    rf-channel 18 tsid 18 output-port-number 23
  bind-vcg
    vcg vcg-pme sdg sdg-pme
  logical-edge-device led-pme id 1
  protocol table-based
    virtual-edge-input-ip 174.101.1.1 vrf Video-VOD-Vrf input-port-number 1
    vcg vcg-pme
  discovery-protocol d6
    mgmt-ip 1.25.2.7
    vendor-string cBR8
    streaming-zone 3509
    component-name led56100
    d6-server 1.200.1.99 17654
  timeout 20
    holdtime 60
  active

```

```

table-based
  vcg vcg-pme
    rf-channel 18
    session sess1 input-port 1 start-udp-port 49152 num-sessions-per-qam 2 processing-type
remap start-program 1 jitter 100 cbr

```

Deployment Scenario for the D6 Discovery Protocol

The diagram below depicts a typical topology for the D6 feature:

Figure 1: D6 Deployment

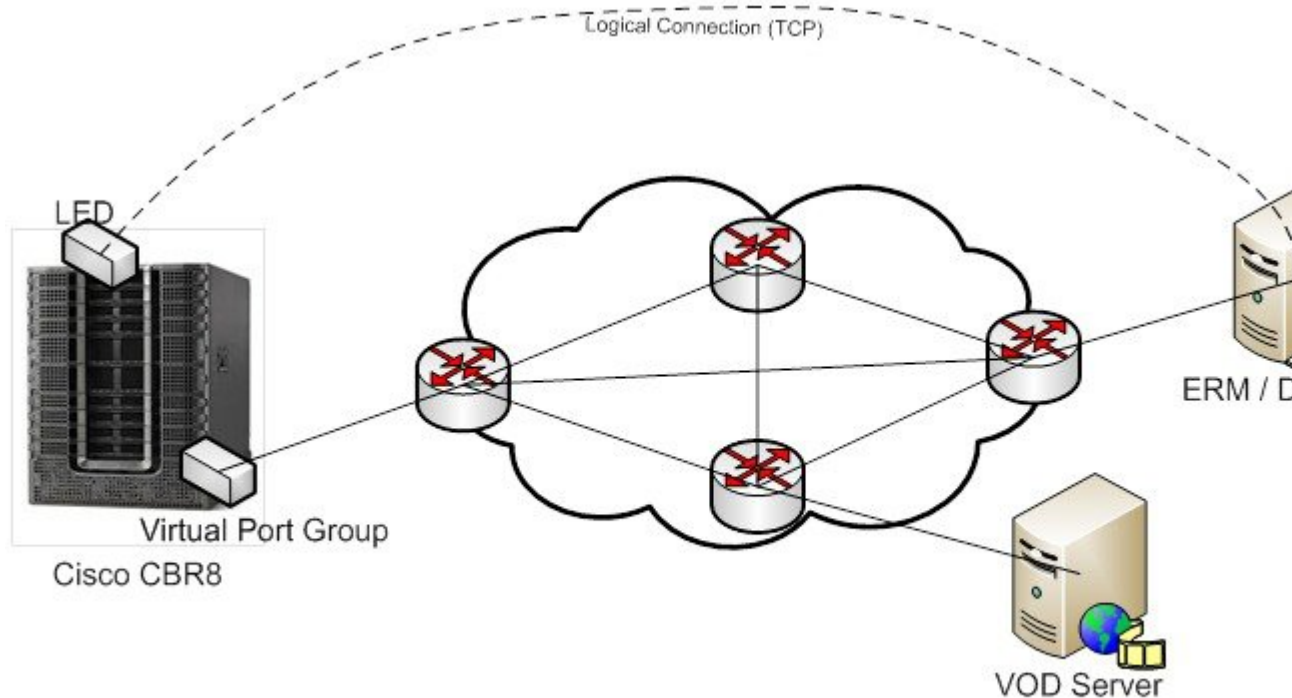

- The advertised edge input IPs over D6 protocol to ERM makes the ERM aware of the edge input options for the QAMs. When multiple VEI IP features are used, the D6 advertises all of the available VEI IPs to the ERM. This enables the ERM to identify the most feasible edge input IP for sending the video traffic to the QAMs, based on the physical topology.
- As D6 advertises the QAMs available in the LED, and updates the ERM whenever new QAMs are added or the existing QAMs are removed, the ERM is always updated about the resources that it owns.
- D6 advertises the UDP port used for each MPEG program number of the table-based sessions. This enables the ERM to identify the proper use of UDP ranges for each TSIDs or QAMs.

Feature Information for D6 Discovery Protocol

Table 19: Feature Information for D6 Discovery Protocol

Feature Name	Releases	Feature Information
D6 Discovery Protocol	Cisco IOS XE Everest 16.5.1	This feature was integrated on the Cisco cBR Series Converged Broadband Routers.



CHAPTER 19

Switched Digital Video

- [Switched Digital Video Services, on page 115](#)
- [Information About Switched Digital Video, on page 117](#)
- [How to Configure the Switched Digital Video Services, on page 118](#)
- [Configuration Examples for Switched Digital Video, on page 122](#)
- [Feature Information for Switched Digital Video, on page 125](#)

Switched Digital Video Services

The Switched Digital Video (SDV) services are supported for the MPEG video subsystem on the Cisco cBR-8 router. It consists of Multicast IP Packet based video streams that are managed as "Video Sessions". The Cisco cBR-8 router supports both Any Source Multicast (ASM) and Source Specific Multicast (SSM) sessions.

- For ASM, the input is identified by the group IP address.
- For SSM, the input is identified by the source and group IP address pair.

In both cases, the UDP ports are ignored. Both ASM and SSM can co-exist but cannot overlap in a group IP address. Hence, for a group IP address, either a single ASM, or one or more SSM can be used.

Session Cloning

Session cloning refers to the ability of forwarding an input to multiple output QAM channels. Only multicast sessions can be cloned. The output QAM channels are located on the same or different line cards. However, an input cannot be cloned on the same QAM channel. Cloning is available on session-based GQIv2 or Table-based sessions. It is applicable to re-mapped, pass-through, and data piping sessions. All cloned sessions must have the same processing type, bitrate and jitter value. For re-mapped sessions, each output copy will have a different output program number.

Redundant Multicast Sources

The redundant multicast sources feature supports up to four SSM/ASM multicast address pairs per video session. However, only multicast traffic from one source is forwarded to the output QAMs. When the active source fails, another source is chosen automatically. Multicast sources must be unique within a redundant group and cannot overlap across redundant groups.

The order of the sources is critical when multicast sessions are configured via GQI or VSRM. For a given group IP address, the source IP addresses must be specified in the same order.

For example: The group IP address 232.1.2.3 used with two sessions must have the source IP addresses specified in the same order.

Session A configured with group IP 232.1.2.3 source 174.2.3.4 source2 174.4.5.6 source3 174.7.8.9 and session B or any session created after session A configured using group IP 232.1.2.3, must have the source IP addresses in this same order as specified for session A. That is, source 174.2.3.4 source2 174.4.5.6 source3 174.7.8.9.

This ensures that all sessions switch to the same source IP address when a source switch occurs. Additionally, sessions configured via GQI have up to three sources available for redundancy, whereas multicast labels configured for table-based sessions have up to four sources available for redundancy.

Multicast labels must use unique groups and S/G pairs. These pairs cannot be used by other multicast labels or by multicast sessions that use S/G pairs. For example, when one multicast session uses {[S1, G], [S2, G] and [S3, G]}, another session cannot use {[S1, G], [S4, G]}.

Multicast source change is based on the session state; INIT, IDLE, ACTIVE or OFF. A session configured for the first time is in INIT state and stays in this state for a brief time. If traffic starts before the INIT timer expires, it moves to the ACTIVE state, otherwise to the IDLE state.

When traffic starts, the session remains in ACTIVE state as long as traffic continues to flow. When traffic stops for a time longer than the IDLE timer, the session moves to IDLE state. During IDLE state, PAT and PMT of the session is retained as the output. If traffic resumes in this state, the session moves to ACTIVE state again with all its previous PSI and remapping information unaltered.

In IDLE state, if traffic does not start or resume before the OFF timer expires, the session transitions to OFF state. When traffic resumes for a session in OFF state, it is treated as a new session.

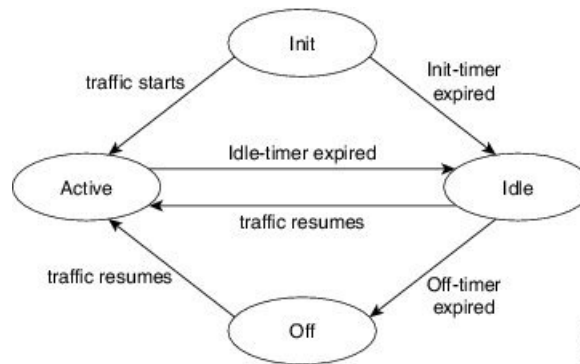

Sessions that transition from ACTIVE to IDLE have higher priority and will be moved to the backup source than those that were newly created and have changed from INIT to IDLE.

Benefits of Switched Digital Video

Switched Digital Video provides the following benefits:

- Saves space, maintenance and cost.
- Allows customers to oversubscribe bandwidth.

Prerequisites for Switched Digital Video

- To access multicast capability, configure multicast routing.
- To switch sources for table-based sessions, configure at least two sources for a multicast label and then associate with the desired session.

Restrictions for Switched Digital Video

- While creating a multicast label, up to four sources can be associated with one group IP address.
- Labels are used with table-based video sessions only.
- Sessions created with GQI Tools do not use labels. However, they can have up to three sources associated with one group IP address.

Information About Switched Digital Video

QAM Sharing

Unicast and multicast video sessions can co-exist on the same QAM channel for VOD, SDV or Gaming sessions. QAM sharing requires a common Edge Resource Manager to avoid oversubscription of QAM resources between services.



Note QAM sharing with MPTS pass-thru sessions is not supported.

QAM Replication

Multicast sessions can be replicated from one port to other ports on the same line card and/or across line cards.

The difference between a cloned session and replicated sessions is:

- Cloned sessions are initiated by a user on session creation. Each session has a unique session id and may have different output configuration.
- Replicated sessions have the same output configuration attributes. For sessions that are replicated across line cards, session on each line card will have its own unique session id.

MPTS Pass-through Session

Switched digital video (SDV) sessions are typically multicast SPTS remap type. The Cisco cBR-8 router also supports multicast MPTS pass-through and data-piping session types.

The MPTS session is assumed to have no collision in the PID space and program number space with other sessions that already exist within a QAM. Hence, SPTS remap and MPTS pass-through sessions cannot

co-exist on the same QAM. Otherwise, there might be conflict when the PID and program numbers in the MPTS and SPTS remuxing are not unique on the output QAM channel.

For a pass-through session:

- The PAT is snooped and regenerated with the correct TSID.
- The PMT and other program data are not changed.
- PID remapping is not performed.
- Input NULL packets are dropped.
- Oversubscription results in random TP dropping, and all ghost PIDs are preserved in the output.

How to Configure the Switched Digital Video Services

Configuring Multicast Routing

You can enable IP Multicast Distributed Switching (MDS) to provide distributed switching of multicast packets received at the line cards.

```
enable
configure terminal
ip multicast-routing distributed
ip pim ssm range all-multicasts
ip pim rp-address ip-address
interface type number
ip pim sparse-dense-mode
ip igmp version 3
cable video
multicast-uplink interface-name access-list access-list-name
```

When more than one physical or logical interfaces are used for reverse path forwarding (RPF) lookup, use loopback interface in **multicast-uplink** command and make sure that the loopback interface is routable/reachable on your network. Loopback interface of the cBR-8 can be enabled with **ip pim sparse-mode** command and it is reachable to multicast source or reverse path.

Below is an example of configuration:

```
Router> enable
Router# configure terminal
Router(config)# cable video
Router(config-video)# multicast-uplink 'Loopback0' access-list "acl_name1" access-list-global
"acl_name2" rp "rp-address"

Router(config)# interface Loopback0
Router(config-if)# ip address <ipaddress> <mask>
Router(config-if)# ip pim sparse-mode
Router(config-if)# end

Router(config)# ip access-list standard acl_name2
Router(config-std-nacl)# 10 permit 232.0.0.0 0.255.255.255
Router(config-std-nacl)#20 permit 227.0.0.0 0.255.255.255
```

```
Router(config-std-nacl)#30 permit 228.0.0.0 0.255.255.255
Router(config-std-nacl)#40 permit 231.0.0.0 0.255.255.255
Router(config-std-nacl)#50 permit 230.0.0.0 0.255.255.255
```

```
Router(config)# ip access-list standard acl_name1
Router(config-std-nacl)#10 permit 232.0.0.0 0.255.255.255
Router(config-std-nacl)#20 permit 231.0.0.0 0.255.255.255
```

`acl_name1` is a named-access-list to provisioned by user which provides multicast prefix belong to SSM range. Default is 232.*.*

`acl_name2` is a named-access-list to provisioned by user which provides multicast prefix belong to both SSM/ASM range.

`rp-address` is the actual IP address of the RP if ASM used.

Configuring Multicast Label

The Cisco cBR-8 router supports up to four multicast address pairs per multicast session for backup purpose. To specify additional sources for a multicast session for table-based, a label needs to be configured and attached to the session configuration. A maximum of 2000 multicast labels can be created but only 2048 multicast addresses can be active at a time.

Multicast label is used for table-based session configuration when more than one multicast source [S, G] is used as backup for the sessions. A multicast label can only be created or deleted; it cannot be modified. The multicast label cannot be deleted before the sessions using it are removed.

Groups used by multicast labels must be unique like the multicast S/G pairs. However, sources may be used by more than one label as long as the group is unique. A maximum of 4 multicast sources is allowed in one label. If the label is used in multiple sessions, the sessions are considered as cloned sessions.

```
enable
configure terminal
  cable video
    table-based
      multicast-label label group group-ip source source-ip source2 source-ip source3
        source-ip source4 source-ip
```

Configuring Multicast Table-based Sessions

Similar to table-based unicast session configuration, sessions can be configured as individual sessions under each QAM carrier that is assigned to a table-based LED.

A multicast session can be configured with a single input multicast input source or multiple input sources for backup purpose. For multiple backup sources, a label is required to be associated with the session configuration. Same label can be applied to multiple sessions on different QAM channel. These sessions are considered as cloned sessions.

For session cloning on multiple QAMs within the same line card, only one copy of the traffic is forwarded to the line card. The line card replicates the input packets and forwards them to multiple QAMs. Each cloned copy of a remapped session will have the same or different output program number.

```
enable
configure terminal
```

```

cable video
  table-based
  vcg vcg-name
  rf-channel channel
  session session-name group group-ip source source-ip processing-type {remap
| passthru | data} start-program program-num [bit-rate bit-rate-number] [jitter
jitter-number] [cbr | vbr]

```

Configuring Source Switching

Source switching happens automatically when the current source goes down. If more than one source IP is configured, the software will automatically switch to the next valid source IP, if it is available. However, to force switch from one valid source to another valid source, use the following commands:

```

Router(config)# cable video source-switch from-group group-ip from-source
source-ip

```

or

```

Router(config)# cable video source-switch to-group group-ip to-source source-ip

```

Verifying Switched Digital Video Configuration

```

Router#show cable video session logical-edge-device id 2
Total Sessions = 4

```

Session Input Id State	Output Output Port State	Streaming Input Type Bitrate	Output Output Type Bitrate	Session Encrypt Type	Session Encrypt Ucast Dest Status	Source IP/Mcast IP	Session IP (S,G) Name	UDP Port	Output Program
2097152	142 ON 0	Remap 0	SSM CLEAR	175.2.5.6,232.5.6.7	-	SESS_PME2.1.7.338	0	1	OFF
2097153	163 INIT ON 0	Remap 0	SSM CLEAR	175.6.1.13,232.2.1.6	-	SESS_PME3.1.7.497	0	2	
2097154	184 ON 0	Passthru 0	SSM CLEAR	175.2.6.7,232.5.6.15	-	SESS_PME4.1.7.656	0	-	OFF
2097155	230 ON 0	Data-Piping 0	SSM CLEAR	175.7.2.2,232.2.6.7	-	SESS_PME6.1.7.978	0	-	OFF

```

Router#show cable video session logical-edge-device id 2 session-id 2097152
Session Name      : SESS_PME2.1.7.338
Session Id       : 2097152
Creation Time    : Fri Jun 24 16:30:45 2016

```

```

Output Port      : 142
TSID             : 142
ONID             : 0
Number of Sources : 1
  Source IP      : 175.2.5.6
  Group IP       : 232.5.6.7
  UDP Port       : 0
Config Bitrate   : not specified
Jitter           : 100 ms
Processing Type   : Remap

```

```
Stream Rate      : VBR
Program Number   : 1
Idle Timeout     : 2000 msec
Init Timeout     : 2000 msec
Off Timeout      : 60 sec
Encryption Type  : CLEAR
Encryption Status : -
```

Input Session Stats:

```
=====
State: OFF, Uptime: 0 days 00:26:35
IP Packets: In 0, RTP 0, Drop 0
TP Packets: In 0, PCR 0, PSI 0, Null 0
             Unreference 0, Discontinuity 0
Errors: Sync loss 0, CC error 0, PCR Jump 0,
        Underflow 0, Overflow 0, Block 0
Bitrate: Measured 0 bps, PCR 0 bps
```

Output Session Stats:

```
=====
State: ON, Uptime: 0 days 00:26:35
TP Packets: In 0, PCR 0, PSI 0,
             Drop 0, Forward 0, Insert 0
Errors: Info Overrun 0, Info Error 0, Block 0, Overdue 0,
        Invalid Rate 0, Underflow 0, Overflow 0
Bitrate: Measured 0 bps
```

Troubleshooting Switched Digital Video Configuration

Problem	Possible Causes	Recommended Solution
%ERROR: Duplicate multicast source 175.2.5.6 group 232.5.6.7 not allowed for use in label groupDuplicate.	Group and Source are already used in an existing label.	Assign unique group and source IPs across multicast labels.
%ERROR: Duplicate multicast source 178.3.3.3 group 232.222.222.222 not allowed within label DuplicateSourceHere.	Source has been repeated within a label.	Assign unique source IP within a multicast label.
%ERROR: Duplicate multicast source 175.2.5.6 group 232.5.6.7 not allowed for use in this session.	Session has been created with a duplicate group IP. This group IP has been used in an existing multicast label.	Create the session with a unique group IP.
%ERROR Only one multicast session can be created per multicast session command; rf-channel range values, such as rf-channel 20-30, not allowed.	Session has been created on a range of RF channels.	RF channel range is not allowed. Create the session on an RF channel.

Configuration Examples for Switched Digital Video

Example 1: Table-based Multicast Session Configuration

```

enable
configure terminal
ip pim rp-address 9.1.1.1
ip pim ssm range all-multicasts
ip access-list standard all-multicasts
permit 233.0.0.0 0.255.255.255
permit 234.0.0.0 0.255.255.255
permit 235.0.0.0 0.255.255.255
permit 236.0.0.0 0.255.255.255
permit 237.0.0.0 0.255.255.255
permit 238.0.0.0 0.255.255.255
permit 232.0.0.0 0.255.255.255
permit 224.0.0.0 0.255.255.255
permit 239.0.0.0 0.255.255.255
interface TenGigabitEthernet4/1/2
ip address 2.33.1.1 255.255.255.252
ip pim sparse-mode
ip igmp version 3
ip ospf 64512 area 9
load-interval 30
cable video
multicast-uplink TenGigabitEthernet4/1/2 access-list all-multicasts
service-distribution-group sdg-1 id 1
  rf-port integrated-cable 7/0/0
virtual-carrier-group vcg-1 id 1
  service-type narrowcast
  rf-channel 0-55 tsid 1-56 output-port-number 1-56
bind-vcg
  vcg vcg-1 sdg sdg-1
logical-edge-device led_multicast id 1
  protocol table-based
  virtual-edge-input-ip 174.102.1.1 input-port-number 1
  vcg vcg-1
  active
table-based
  multicast-label label1 group 232.2.1.1 source 175.2.2.2
  vcg vcg-1
  rf-channel 0
    session mcast1 multicast-label label1 processing-type remap start-program 1 jitter
100 vbr
    session mcast2 group 236.0.1.1 source 175.10.5.2 processing-type passthru jitter
100 cbr

```

Example 2: Table-based Configuration for Replicated Multicast Pass-through Sessions

Below is a table-based configuration for multicast pass-through sessions replicated to all QAM ports on the same line card.

```

enable
configure terminal
cable video

```



```

multicast-uplink TenGigabitEthernet4/1/2 access-list all-multicasts
service-distribution-group sdg1 id 1
  rf-port integrated-cable 7/0/0
  rf-port integrated-cable 7/0/1
  rf-port integrated-cable 7/0/2
  rf-port integrated-cable 7/0/3
  rf-port integrated-cable 7/0/4
  rf-port integrated-cable 7/0/5
  rf-port integrated-cable 7/0/6
  rf-port integrated-cable 7/0/7
virtual-carrier-group vcg1 id 1
  rf-channel 0-95 tsid 0-95 output-port-number 1-96
bind-vcg
  vcg vcg1 sdg sdg1
logical-edge-device led1 id 1
  protocol table-based
    virtual-edge-input-ip 174.102.1.1 input-port-number 1
    vcg vcg1
    active
  table-based
    multicast-label mlabel1 group 236.0.1.1 source 175.10.5.2 source2 175.10.6.20 source3
175.10.7.2
    vcg vcg1
      rf-channel 0
        session mcast1 multicast-label mlabel1 processing-type passthru vbr
      rf-channel 5
        session mcast2 group 237.0.1.1 source 175.10.6.2 processing-type passthru vbr

```

Example 3: QAM Sharing Configuration

Below is an example of how to create a PMT encrypted table-based session for both VOD and SDV on the same QAM channel on 7/0/0 RF port.

```

cable video
multicast-uplink TenGigabitEthernet4/1/2 access-list all-multicasts
mgmt-intf VirtualPortGroup 0
encryption
  linecard 7/0 ca-system pme scrambler dvs042
  pme vodsid 111
  pme cem 1.200.1.163 5000
  pme mgmt-ip 1.33.2.6
service-distribution-group sdg1 id 1
  rf-port integrated-cable 7/0/0
virtual-carrier-group vcg1 id 1
  virtual-edge-input-ip 174.102.1.1 input-port-number 1
  encrypt
  service-type narrowcast
  rf-channel 20-34 tsid 20-34 output-port-number 20-34
bind-vcg
  vcg vcg1 sdg sdg1
logical-edge-device led1 id 1
  protocol table-based
    vcg vcg1
    active
  table-based
    multicast-label mlabel1 group 236.0.1.1 source 175.10.5.2 source2 175.10.6.2 source3
175.10.7.2
    vcg vcg1
      rf-channel 20
        session VOD input-port 1 start-udp-port 49152 processing-type remap start-program
1 jitter 100 vbr

```

```

    session SDV multicast-label mlabell processing-type remap start-program 1000 jitter
100 vbr
!
```

Example 4: QAM Replication Configuration

Below is an example of how to configure multicast sessions with four backup sources and replicated on multiple line cards and multiple RF ports within the same line card.

```

cable video
 multicast-uplink TenGigabitEthernet4/1/2 access-list all-multicasts
 service-distribution-group sdg-1 id 1
   rf-port integrated-cable 7/0/0
   rf-port integrated-cable 7/0/1
   rf-port integrated-cable 8/0/0
   rf-port integrated-cable 8/0/1
 virtual-carrier-group vcg-1 id 1
   service-type broadcast
   rf-channel 0-55 tsid 1-56 output-port-number 1-56
bind-vcg
 vcg vcg-1 sdg sdg-1
 logical-edge-device led_multicast id 1
 protocol table-based
   virtual-edge-input-ip 174.102.1.1 input-port-number 1
   vcg vcg-1
 active
 table-based
   multicast-label labell group 232.2.1.1 source 175.2.2.2 source2 175.2.3.2 source3
175.2.4.2 source4 175.5.1.12
   vcg vcg-1
   rf-channel 0
     session mcast1 multicast-label labell processing-type remap start-program 1 jitter
100 vbr
```

Example 5: SSM Session Configuration

The following examples show how to configure SSM sessions on a range of QAM channels with three multicast sources.

```

table-based
 multicast-label labell110_1 group 232.2.1.35 source 175.2.2.2 source2 175.6.1.12 source3
175.2.9.2
 multicast-label labell103_1 group 232.2.1.30 source 175.2.2.2 source2 175.6.1.12 source3
175.2.9.2
   vcg vcg-uni-multi0
   rf-channel 0
     session mcast multicast-label labell110_1 processing-type remap start-program 1
jitter 100 cbr
   rf-channel 6
     session mcast multicast-label labell103_1 processing-type remap start-program 1
jitter 100 cbr
```

Example 6: Multicast Session with Virtual Carrier Group as Service Type Broadcast Configuration

```

virtual-carrier-group VCG_PME0 id 1
 service-type broadcast
 rf-channel 20-35 tsid 100-115 output-port-number 100-115
```

```

table-based
multicast-label a2 group 232.5.6.7 source 175.2.5.6
multicast-label exampleLabel group 232.2.1.6 source 175.6.1.13 source2 175.6.1.12 source3
180.1.1.1 source4 175.6.1.14
vcg VCG_PME2
rf-channel 22
session SESS_PME2 multicast-label a2 processing-type remap start-program 1
vcg VCG_PME3
rf-channel 23
session SESS_PME3 multicast-label exampleLabel processing-type remap start-program
2

```

Example 7: Sessions with Passthru and Data Processing Type

```

table-based
multicast-label a2 group 232.5.6.7 source 175.2.5.6
multicast-label exampleLabel group 232.2.1.6 source 175.6.1.13 source2 175.6.1.12 source3
180.1.1.1 source4 175.6.1.14
vcg VCG_PME2
rf-channel 22
session SESS_PME2 multicast-label a2 processing-type remap start-program 1
vcg VCG_PME3
rf-channel 23
session SESS_PME3 multicast-label exampleLabel processing-type remap start-program
2
vcg VCG_PME4
rf-channel 24
session SESS_PME4 group 232.5.6.15 source 175.2.6.7 processing-type passthru
vcg VCG_PME6
rf-channel 30
session SESS_PME6 group 232.2.6.7 source 175.7.2.2 processing-type data

```

Feature Information for Switched Digital Video

Feature Name	Releases	Feature Information
Switched Digital Video	Cisco IOS XE Everest 16.5.1	This feature was integrated on the Cisco cBR Series Converged Broadband Routers.



CHAPTER 20

DVB Video on Demand

The Digital Video Broadcasting (DVB) protocol for encrypting the video services as defined in the ETSI TS 103 197 DVB Simulcrypt specification has been implemented in the cBR-8. This document contains an overview of the commands for configuring DVB on the cBR-8 chassis and the commands for viewing the status of the encryption of services.

Contents

- [Information About DVB VOD, on page 127](#)
- [How to Configure DVB, on page 129](#)
- [Configuration Examples, on page 133](#)
- [Additional References, on page 135](#)
- [Feature Information for DVB Video on Demand, on page 136](#)

Information About DVB VOD

Overview of DVB VOD

This feature enables the operator to scramble the video sessions on the chassis. It involves the configuration to establish a connection with the Entitlement Control Message Generator (ECMG) and the Event Information Scheduler (EIS).

The two primary modes of scrambling are: session based scrambling and tier-based scrambling. The basic difference between the two modes is that the manner in which the Entitlement Control Messages (ECM) are requested from the ECMG. For session based scrambling, a control word (CW) is generated once every Crypto Period (CP) and the ECM is requested for each session. For tier-based scrambling, the control word is generated once every CP and the ECM generated by the ECMG for the CW is used by all the sessions in the linecard.

Session based Scrambling Setup

The connection with the external EIS Server is established via the Virtual Port Group in the Supervisor. The connection with the external ECMG server is established via the linecard.

Figure 2: Session based Setup

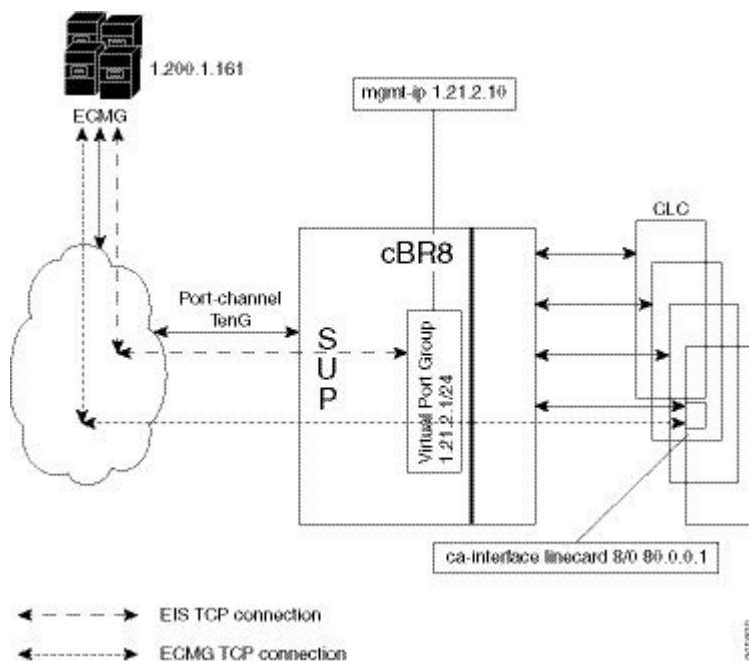

Fail-to-Clear

The fail-to-clear-duration feature is supported on DVB sessions and DualCrypt encryption modes. Based on the session encryption, the following two features are supported on the Cisco cBR Series Converged Broadband Routers.

Fail-to-Clear Duration for DVB Session-based Encryption

This feature is used along with DVB or DualCrypt encryption with external Event Information Scheduler (EIS) configuration. When encryption for a session fails in Cisco cBR-8, this feature enables the operator to control the configured DVB-encrypted sessions to function without encryption for a configured duration. If the encryption still fails, the DVB session is marked as `Fail-to-black` after the fail-to-clear duration timeout.

Fail-to-Clear for DVB Tier-based Encryption

This feature is used along with Tier-based configuration. When encryption for a session fails in Cisco cBR-8, this feature enables the operator to control the configured DVB-encrypted sessions to function without encryption.

If fail-to-clear is configured, tier-based configuration is enabled, and then if the encryption fails, the DVB session's `Encrypt Status` is marked as `clear`. The status changes to `Encrypted` when the encryption starts.

This feature is not enabled by default.

Tier based Scrambling Setup

The connection with the external ECMG server is established via the Virtual Port Group in the Supervisor.

Figure 3: Tier based Setup

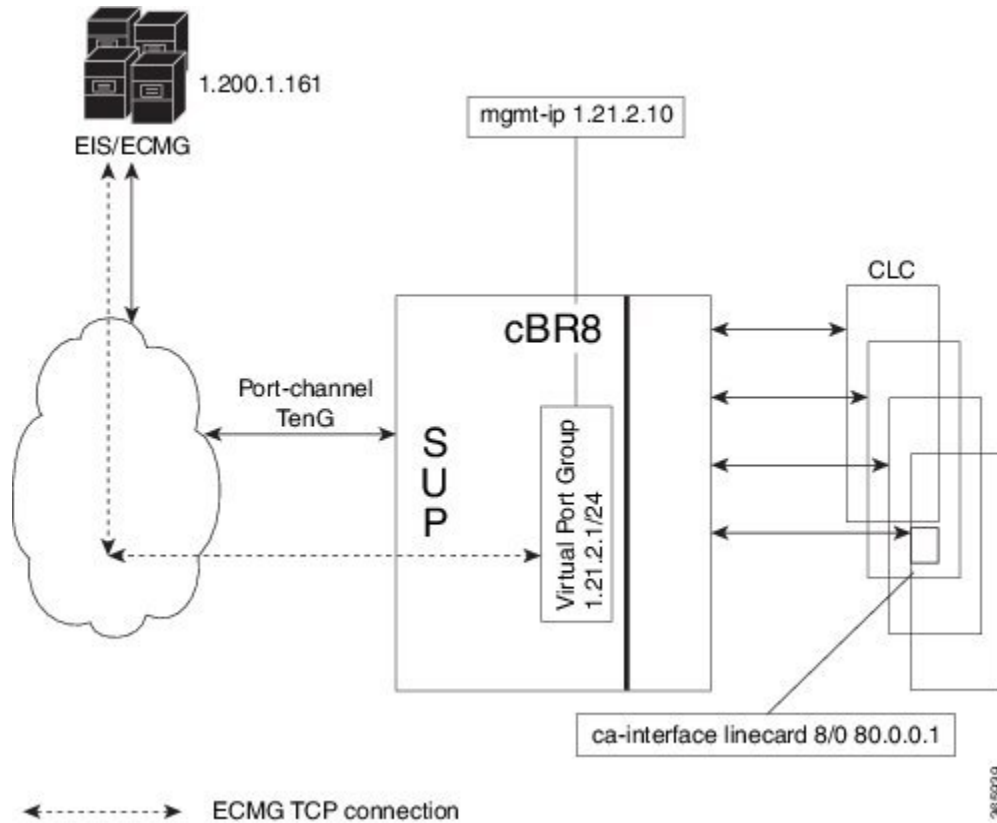

Restrictions for DVB

- This feature is applicable only for remapped table based sessions.
- Fail-to-clear-duration feature is applicable only to session-based scrambling for DVB CAS encryption.
- Fail-to-clear feature is applicable only to DVB tier-based scrambling sessions.

How to Configure DVB

Configuring DVB

Before You Begin

- Virtual Port Group interface must be configured and the management IP for DVB must be identified.
- Management interface is set to this Virtual Port Group interface under cable video configuration.
- Logical Edge Device is configured with the table based protocol.
- The encryption algorithm of the linecard is set to DVB-CSA.

- For session based scrambling, the CA interface on the linecard and the route for reaching the ECMG server must be specified.

To configure session based scrambling, follow the steps below:

```
enable
configure terminal
cable video
mgmt-intf VirtualPortGroup group_id
encryption
linecardslot/bay ca-system dvb scrambler dvb-csa
dvb
route-ecmg ECMG_Server_IP_Address Netmask Interface Forwarding_Router_IP_Address
mgmt-ip ip-address
eis EIS_Name id EIS_ID
listening-port port_number
fail-to-clear-duration < duration in seconds>
ca-interface linecardslot/bay IP_Address
ecmg ECMG_Name id ECMG_ID
mode vod linecardslot/bay
type [standard | hitachi | irdeto | nagra| pkey]
ca-system-id CA_System_ID CA_Subsystem_ID
ecm-pid-source [sid | auto | ecm-id | min-ecm-pid | max-ecm-pid]
connection id id priority connection_priority IP_Address Port
```

The fail-to-clear-duration is measured in seconds. The valid values are in the range from 0 to 10800 seconds. The default value is 0.

To configure tier based scrambling, follow the steps below:

```
enable
configure terminal
cable video
mgmt-intf VirtualPortGroup group_id
encryption
linecardslot/bay ca-system dvb scrambler dvb-csa
dvb
mgmt-ip ip-address
ecmg ECMG_Name id ECMG_ID
mode tier-based
type [standard | hitachi | irdeto | nagra| pkey]
ca-system-id CA_System_ID CA_Subsystem_ID
ecm-pid-source [sid | auto | ecm-id]
connection id id priority connection_priority IP_Address Port
tier-based
ecmg id ECMG_ID access-criteriaaccess_criteria_in_hex
fail-to-clear
enable
```



Note If the tier-based configuration is already enabled, you must first disable the tier-based configuration using the **no enable**, before you configure fail-to-clear feature.

Verifying the DVB Configuration

To verify the configuration of the encryption algorithm on the linecard, use the **show cable video encryption linecard** command as shown in the example below:

```
Router# show cable video encryption linecard 7/0
Line card: 7/0
CA System      Scrambler      DVB-Conformance
=====
dvb            dvb-csa        Enabled
```

To verify the ECMG connection, use the **show cable video encryption dvb ecmg id id connection** command as shown in the example below:

```
Router# show cable video encryption dvb ecmg id 1 connection
-----
ECMG ECMG      ECMG      CA Sys CA Subsys PID      Lower Upper Streams/ Open Streams/
Auto Chan Slot ECMG      ECMG
ID   Name      Type      ID   ID           Source limit limit ECMG      ECMG      ID
              Connections Application
-----
1   polaris_ecmg01 standard 0x4748 0x0          sid    0    0    1    1
Enabled RP 1          Tier-Based
```

ECMG Connections for ECMG ID = 1

```
-----
Conn Conn      IP          Port      Channel  Conn      Open
-ID  Priority Address      Number  ID           Status  Streams
-----
1    1          10.10.1.1  8888     1          Open     1
```

The sample output of the session based scrambling configuration verification command is shown below:

```
Router# show cable video encryption dvb ecmg id 7 connection
-----
ECMG ECMG      ECMG      CA Sys CA Subsys PID      Lower Upper Streams/ Open Streams/
Auto Chan Slot ECMG      ECMG
ID   Name      Type      ID   ID           Source limit limit ECMG      ECMG      ID
              Connections Application
-----
7   ecmg-7      standard 0x950 0x1234      sid    0    0   1680  1680
Enabled 7 1          VOD
```

ECMG Connections for ECMG ID = 1

```
-----
Conn Conn      IP          Port      Channel  Conn      Open
-ID  Priority Address      Number  ID           Status  Streams
-----
1    1          10.10.1.10 8888     1          Open     1
```

The status of the connection with the ECMG Server is indicated by the Conn Status. The Open Streams field indicates the number of Active ECM Streams.

To verify the EIS connection, use the **show cable video encryption dvb eis id id** command as shown in the example below:

```
Router# show cable video encryption dvb eis id 1
-----
EIS EIS Peer      Management TCP CP      CP      Overwrite Fail-To-Clear Connection
ID  Name IP          IP          Port Overrule Duration SCG      Duration      Status
```

```
-----
1 test 10.10.1.11 10.10.1.1 9898 DISABLED 0 DISABLED 400 Connected
```

To verify the CA Interface configuration in the case of session based scrambling, use the **show cable video encryption dvb ca-interface brief** command as shown in the example below:

```
Router# show cable video encryption dvb ca-interface brief
```

```
CA Interface configuration
```

```
-----
Linecard   IP Address   VRF
-----
7          10.10.1.1   N/A
```

```
ECMG Route configuration
```

```
-----
IP Address   NetMast       Interface
-----
10.10.1.10   255.255.255.224 TenGigabitEthernet4/1/2
```

To verify the encryption status of the sessions, use the **show cable video session logical-edge-device id** command as shown in the example below:

```
Router# show cable video session logical-edge-device id 1
```

```
Total Sessions = 1
```

```
-----
Session Output Streaming Session Session Source          UDP   Output  Input
Output Input  Output  Encrypt Encrypt  Low    Session
Id      Port   Type    Type    Ucast Dest IP/Mcast IP (S, G) Port  Program State
State  Bitrate Bitrate Type    Status  Latency Name
-----
1048576 1      Remap   UDP     10.10.1.1          49167 20      ACTIVE-PSI
      1695161 1689747 DVB     Encrypted N          dvbssess.1.0.1.0.23167
```

To verify the ECM PID and whether the CA Descriptor is added to the PMT, use the **show cable video session logical-edge-device id session-id** command as shown in the example below:

```
Router# show cable video session logical-edge-device id 1 session-id 1048576
```

```
Output PMT Info:
```

```
=====
Program 20, Version 3, PCR 49, Info len 18, (CA SYS-ID 4748, PID 79)
PID 49: Type 2, Info len 0
PID 50: Type 3, Info len 6, (lang eng)
```

Troubleshooting Tips

If some configuration errors occur, see the following troubleshooting tips:

- The Management IP must be unique and in the subnet of virtual port group.
- Ensure that the ECMG Server is pingable with source interface as the virtual port group from the Cisco cBR-8 console. This indicates that the ECMG Server is reachable and route is valid.
- Ensure that the TCP port number configured for the ECMG Server in the Cisco cBR-8 is the same as that of the ECMG Server listening port.
- Ensure that the management IP is pingable from the EIS Server. Otherwise, check the routing between the cBR-8 chassis and the EIS server.

- Ensure that the listening port that is configured for the EIS is used for establishing the connection from the EIS Server.
- Ensure that the Virtual Port Group interface is active.
- Ensure that the TenGigabitEthernet interface using which the management traffic reaches the Cisco cBR-8 and the interface through which the CA interface route is configured are active.

Configuration Examples

This section provides examples for the DVB configuration.

Example 1: Basic Session-based Scrambling Configuration

```

Router>enable
Router#config terminal
Router(config)#interface VirtualPortGroup0
Router(config-if)#vrf forwarding vrf_script_red_1
Router(config-if)#ip address 10.10.1.1 255.255.255.224
Router(config-if)#no mop enabled
Router(config-if)#no mop sysid
Router(config-if)#exit
Router(config)#cable video
Router(config-video)#mgmt-intf VirtualPortGroup 0
Router(config-video)#encryption
Router(config-video-encrypt)#linecard 7/0 ca-system dvb scrambler dvb-csa
Router(config-video-encrypt-dvb-conf)#exit
Router(config-video-encrypt)#dvb
Router(config-video-encrypt-dvb)#scramble-video-audio
Router(config-video-encrypt-dvb)#route-ecmg 10.10.1.1 255.255.255.224 TenGigabitEthernet4/1/2
  10.10.1.1
Router(config-video-encrypt-dvb)#mgmt-ip 10.10.1.1
Router(config-video-encrypt-dvb)#eis eis-1 id 1
Router(config-video-encrypt-dvb-eis)#listening-port 8890
Router(config-video-encrypt-dvb-eis)#fail-to-clear-duration 400
Router(config-video-encrypt-dvb-eis)#cp-override 60
Router(config-video-encrypt-dvb-eis)#overwrite-scg
Router(config-video-encrypt-dvb-eis)#exit
Router(config-video-encrypt-dvb)#ca-interface linecard 1/0 10.10.1.1 vrf vrf_script_red_1
Router(config-video-encrypt-dvb)#ecmg ecmg-7 id 7
Router(config-video-encrypt-dvb-ecmg)#mode vod linecard 7/0
Router(config-video-encrypt-dvb-ecmg)#type standard
Router(config-video-encrypt-dvb-ecmg)#ca-system-id 950 1234
Router(config-video-encrypt-dvb-ecmg)#auto-channel-id
Router(config-video-encrypt-dvb-ecmg)#ecm-pid-source sid
Router(config-video-encrypt-dvb-ecmg)#connection id 1 priority 1 10.10.1.1 8888
Router(config-video-encrypt-dvb-ecmg)#desc-rule desc_8_1 id 1
Router(config-video-encrypt-dvb-ecmg-desc)#add-priv-data at-es-level private-data 12345678
  ecm-ids 81,82,83,84,85
Router(config-video-encrypt-dvb-ecmg-desc)#exit
Router(config-video-encrypt-dvb-ecmg)#override
Router(config-video-encrypt-dvb-ecmg-override)#max-comp-time 10000
Router(config-video-encrypt-dvb-ecmg-override)#min-cp-duration 60000
Router(config-video-encrypt-dvb-ecmg-override)#start-delay -5000
Router(config-video-encrypt-dvb-ecmg-override)#rep-period 125
Router(config-video-encrypt-dvb-ecmg-override)#max-streams 1920
Router(config-video-encrypt-dvb-ecmg-override)#end
Router#config terminal
Router(config)#cable video

```

Example 2: Basic Tier-based Scrambling Configuration

```

Router(config-video)#service-distribution-group sdg-1 id 1
Router(config-video-sdg)#onid 1
Router(config-video-sdg)#rf-port integrated-cable 7/0/0
Router(config-video-sdg)#end
Router(config-video)#virtual-carrier-group vcg-1 id 1
Router(config-video-vcg)#encrypt
Router(config-video-vcg)#service-type narrowcast
Router(config-video-vcg)#rf-channel 0 tsid 1 output-port-number 1
Router(config-video-vcg)#end
Router(config-video)#bind-vcg
Router(config-video-bd)#vcg vcg-1 sdg sdg-1
Router(config-video-bd)#end
Router(config-video)#logical-edge-device led-1 id 1
Router(config-video-led)#protocol table-based
Router(config-video-led-protocol)#virtual-edge-input-ip 10.10.1.1 input-port-number 1
Router(config-video-led-protocol)#vcg vcg-1
Router(config-video-led-protocol)#end
Router(config-video-led)#end
Router(config-video)#table-based
Router(config-video-tb)#vcg vcg-1
Router(config-video-tb-vcg)#rf-channel 0
Router(config-video-tb-vcg-sess)#session tier_vcg-1 input-port 1 start-udp-port 49152
processing-type remap start-program 1 cbr

```

Example 2: Basic Tier-based Scrambling Configuration

```

Router>enable
Router#config terminal
Router(config)#cable video
Router(config-video)#mgmt-intf VirtualPortGroup 0
Router(config-video)#encryption
Router(config-video-encrypt)#linecard 7/0 ca-system dvb scrambler dvb-csa
Router(config-video-encrypt-dvb-conf)#conformance-dvb
Router(config-video-encrypt-dvb-conf)#exit
Router(config-video-encrypt)#dvb
Router(config-video-encrypt-dvb)#scramble-video-audio
Router(config-video-encrypt-dvb)#strong-pairing-enforce
Router(config-video-encrypt-dvb)#mgmt-ip 10.10.1.1
Router(config-video-encrypt-dvb)#ecmg tier-ecmg-1 id 1
Router(config-video-encrypt-dvb-ecmg)#mode tier-based
Router(config-video-encrypt-dvb-ecmg)#type standard
Router(config-video-encrypt-dvb-ecmg)#ca-system-id 4748 0
Router(config-video-encrypt-dvb-ecmg)#auto-channel-id
Router(config-video-encrypt-dvb-ecmg)#ecm-pid-source sid
Router(config-video-encrypt-dvb-ecmg)#connection id 1 priority 1 10.10.1.1 8888
Router(config-video-encrypt-dvb-ecmg)#desc-rule desc_1 id 1
Router(config-video-encrypt-dvb-ecmg-desc)#add-priv-data at-es-level private-data 12345678
all
Router(config-video-encrypt-dvb-ecmg-desc)#exit
Router(config-video-encrypt-dvb-ecmg)#override
Router(config-video-encrypt-dvb-ecmg-override)#max-comp-time 10000
Router(config-video-encrypt-dvb-ecmg-override)#min-cp-duration 60000
Router(config-video-encrypt-dvb-ecmg-override)#start-delay -5000
Router(config-video-encrypt-dvb-ecmg-override)#rep-period 125
Router(config-video-encrypt-dvb-ecmg-override)#max-streams 1920
Router(config-video-encrypt-dvb-ecmg-override)#exit
Router(config-video-encrypt-dvb-ecmg)#exit
Router(config-video-encrypt-dvb)#tier-based
Router(config-video-encrypt-dvb-tb)#ecmg id 1 access-criteria 1234512345
Router(config-video-encrypt-dvb-tb)#fail-to-clear
Router(config-video-encrypt-dvb-tb)#enable
Router#config terminal
Router(config)#cable video

```

```

Router(config-video)#service-distribution-group sdg-1 id 1
Router(config-video-sdg)#onid 1
Router(config-video-sdg)#rf-port integrated-cable 7/0/0
Router(config-video-sdg)#end
Router(config-video)#virtual-carrier-group vcg-1 id 1
Router(config-video-vcg)#encrypt
Router(config-video-vcg)#service-type narrowcast
Router(config-video-vcg)#rf-channel 0 tsid 1 output-port-number 1
Router(config-video-vcg)#end
Router(config-video)#bind-vcg
Router(config-video-bd)#vcg vcg-1 sdg sdg-1
Router(config-video-bd)#end
Router(config-video)#logical-edge-device led-1 id 1
Router(config-video-led)#protocol table-based
Router(config-video-led-protocol)#virtual-edge-input-ip 10.10.1.1 input-port-number 1
Router(config-video-led-protocol)#vcg vcg-1
Router(config-video-led-protocol)#end
Router(config-video-led)#end
Router(config-video)#table-based
Router(config-video-tb)#vcg vcg-1
Router(config-video-tb-vcg)#rf-channel 0
Router(config-video-tb-vcg-sess)#session tier_vcg-1 input-port 1 start-udp-port 49152
processing-type remap start-program 1 cbr

```

Additional References

Related Documents

Related Topic	Document Title
Configuring Tier-Based Scrambling	<i>Cisco RF Gateway 10 Software Configuration Guide</i>

Technical Assistance

Description	Link
<p>The Cisco Support website provides extensive online resources, including documentation and tools for troubleshooting and resolving technical issues with Cisco products and technologies.</p> <p>To receive security and technical information about your products, you can subscribe to various services, such as the Product Alert Tool (accessed from Field Notices), the Cisco Technical Services Newsletter, and Really Simple Syndication (RSS) Feeds.</p> <p>Access to most tools on the Cisco Support website requires a Cisco.com user ID and password.</p>	http://www.cisco.com/support

Feature Information for DVB Video on Demand

Table 20: Feature Information for DVB Video on Demand

Feature Name	Releases	Feature Information
DVB Video on Demand	Cisco IOS XE Everest 16.5.1	This feature was integrated on the Cisco cBR Series Converged Broadband Routers.
Fail-to-Clear	Cisco IOS XE Everest 16.5.1	This feature was integrated on the Cisco cBR Series Converged Broadband Routers.



CHAPTER 21

DualCrypt Encryption Mode Support

The Dualcrypt Encryption feature enables the Session and Resource Manager (SRM) to configure the PowerKey and DVB CAS sessions on the same line card (LC) of the Cisco cBR-8 Converged Broadband Router.

Finding Feature Information

Your software release may not support all the features that are documented in this module. For the latest feature information and caveats, see the release notes for your platform and software release. The Feature Information Table at the end of this document provides information about the documented features and lists the releases in which each feature is supported.

- [Hardware Compatibility Matrix for Cisco cBR Series Routers, on page 137](#)
- [Information about DualCrypt Encryption Mode, on page 138](#)
- [How to Configure Dualcrypt Encryption Mode, on page 140](#)
- [Configuration Examples, on page 144](#)
- [Feature Information for DualCrypt Encryption Mode, on page 148](#)

Hardware Compatibility Matrix for Cisco cBR Series Routers



Note The hardware components introduced in a given Cisco IOS-XE Release are supported in all subsequent releases unless otherwise specified.

Table 21: Hardware Compatibility Matrix for the Cisco cBR Series Routers

Cisco CMTS Platform	Processor Engine	Interface Cards
Cisco cBR-8 Converged Broadband Router	<p>Cisco IOS-XE Release 16.5.1 and Later Releases</p> <p>Cisco cBR-8 Supervisor :</p> <ul style="list-style-type: none"> • PID—CBR-CCAP-SUP-160G • PID—CBR-CCAP-SUP-60G • PID—CBR-SUP-8X10G-PIC 	<p>Cisco IOS-XE Release 16.5.1 and Later Releases</p> <p>Cisco cBR-8 CCAP Line Cards:</p> <ul style="list-style-type: none"> • PID—CBR-LC-8D30-16U30 • PID—CBR-LC-8D31-16U30 • PID—CBR-RF-PIC • PID—CBR-RF-PROT-PIC • PID—CBR-CCAP-LC-40G-R <p>Cisco cBR-8 Downstream PHY Modules:</p> <ul style="list-style-type: none"> • PID—CBR-D30-DS-MOD • PID—CBR-D31-DS-MOD <p>Cisco cBR-8 Upstream PHY Modules:</p> <ul style="list-style-type: none"> • PID—CBR-D30-US-MOD

Information about DualCrypt Encryption Mode

You can use this feature when you want the PowerKey and DVB sessions on the same QAM channel. This feature is applicable only to GQI-based sessions, as it uses the Generic QAM Interface (GQI) protocol.

To configure the dualcrypt encryption mode, you should set up connections with Event Information Scheduler (EIS) and Entitlement Control Message Generator (ECMG).

Prerequisites for Dualcrypt Encryption Mode

- Ensure that the following components are available on your system before configuring dualcrypt encryption for sessions.
 - Service Distribution Group (SDG)
 - Virtual Carrier Group (VCG) with encrypt
 - Logical Edge Device (LED) with GQI protocol
 - Event Information Scheduler (EIS)
 - Entitlement Control Message Generator (ECMG)
- Ensure that the VCG is bound to SDG

- Ensure that the VCG is associated to LED
- Ensure that the Virtual Edge Input is configured only on LED
- Ensure that the following configurations are available on your system:

- The encryption algorithm of the line card is set to DVB-CSA.

You can set it using the following command:

```
linecard <slot>/<bay> ca-system dualcrypt scrambler dvb-csa
```

- The virtual port group interface is configured and the same is set for the management interface under cable video, because the DVB requires a management IP address for communicating with external servers.

Use the following commands to set the virtual port group interface as management interface for cable video:

```
configure terminal
cable video
mgmt-intf VirtualPortGroup <id>
```

- The CA interface on the line card and the route for reaching the ECMG server are specified for session-based scrambling.

Use the following commands to specify CA interface and the route:

```
ca-interface linecard <slot>/<bay> <IP_Address>
route-ecmg <ECMG_Server_IP_Address> <Netmask> <Interface>
<Forwarding_Router_IP_Address>
```

- The **vrf** **<vrf_name>** keyword is configured for routes to populate on the respective VRFs, if you are using VRF for traffic or management separately. Configure the CA interface with specific VRF name.

```
ca-interface linecard <slot>/<bay> <IP_Address> vrf <vrf_name>
```

- (Optional) The bind option is used to associate EIS with specific IP address or GQI-based LED

To use a single IP address for GQI (create and delete sessions) and EIS (provision/de-provision SCGs), the operator should bind the EIS with GQI-based LED using the IP option and configure the required IP address. The IP address should be the subnet of the configured virtual port group. By default, the EIS uses the management IP address configured under DVB and the GQI uses the management IP address configured under LED for session control.

The following sample commands show how to bind the EIS:

```
configure terminal
cable video
encryption
dvb
eis <name of eis>
listening-port <1-65535> bind ip <ip address>
or
listening-port <1-65535> bind led <id | name> <led id | led name>
```



Note

- If all configured EIS are bound to a specific IP/LED using the bind option, the configuration of management IP address under DVB is optional.
- The bind option is not available in Cisco RF Gateway 10.

Restrictions for DualCrypt Encryption Mode

The following restrictions are applicable for configuring DualCrypt encryption mode:

- The DualCrypt Encryption feature is applicable only to GQI-based remapped sessions.
- Use this feature only for PowerKey, DVB, and Clear sessions.
- Do not use this feature along with tier-based scrambling mode.

How to Configure Dualcrypt Encryption Mode

Configuring DVB Session for DualCrypt Encryption

This section explains how to configure the session-based scrambling with DualCrypt encryption mode.

Procedure

To configure a DVB session for DualCrypt encryption, use the following commands:

```
enable
configure terminal
cable video
mgmt-intf VirtualPortGroup <group_id>
encryption
linecard <lcslot/subslot> ca-system dualcrypt scrambler dvb-csa
dvb
  route-ecmg ECMG_Server_IP_Address Netmask Interface Forwarding_Router_IP_Address
  mgmt-ip IP_Address
  eis EIS_Name id EIS_ID
  listening-port port_number [bind {ip <ip address> | led < id <led id >| name <led name>>}]

ca-interface linecard <slot>/<bay> IP_Address
ecmg ECMG_Name id ECMG_ID
mode vod linecard <slot>/<bay>
type <standard/hitachi/irdeto/nagra/pkey>
ca-system-id CA_System_ID CA_Subsystem_ID
ecm-pid-source <sid/auto/ecm-id>
connection id ID priority connection_priority IP_Address Port
```

Verifying DVB Session for DualCrypt Encryption

To verify the configuration of the encryption algorithm on the linecard, use the **show cable video encryption linecard <slot>/<bay>** command as shown in the efollowing xample:

```
Router#show cable video encryption linecard 8/0
Line card: 8/0
CA System          Scrambler          DVB-Conformance
=====
dualcrypt          dvb-csa            Enabled
```

To verify the scrambler configuration, use the **show cable video encryption scrambler brief** command as shown in the following example:

```
Router#show cable video encryption scrambler brief
Scrambler information
```

```
Chassis wide scrambler: none
```

```
-----
```

Linecard	Current Scrambler	Configured Scrambler
1	Not Ready	None
2	Not Ready	None
3	Not Ready	None
4	Not Ready	None
5	Not Ready	None
6	Not Ready	None
7	dvb-csa	None
8	dvb-csa	dvb-csa
9	des/dvs042	None

```
=====
```

To verify the ECMG connection, use the **show cable video encryption dvb ecmg id <id> connection** command as shown in the following example:

```
Router#show cable video encryption dvb ecmg id <ID> connection
```

```
-----
```

ECMG Slot ID	ECMG Name	ECMG Type	CA Sys ID	CA Subsys ID	PID Source	Lower limit	Upper limit	Streams/ECMG	Open Streams/ECMG	Auto Chan ID
1	test	standard	0x950	0x0	sid	0	0	1	1	Enabled
7	1		VOD							

```
-----
```

```
ECMG Connections for ECMG ID = 1
```

```
-----
```

Conn -ID	Conn Priority	IP Address	Port Number	Channel ID	Conn Status	Open Streams
1	1	10.10.1.1	9878	1	Open	1

```
-----
```

The `Conn Status` field shows the status of the connection with the ECMG server and the `Open Streams` field indicates the number of active ECM streams.

To verify the EIS connection, use the **show cable video encryption dvb eis id <id>** command as shown in the following example:

```
Router#show cable video encryption dvb eis id <ID>
```

```
-----
```

EIS ID	EIS Name	Peer IP	Management IP	TCP Port	CP Overrule	CP Duration	Overwrite SCG	Fail-To-Clear Duration	Connection Status
1	test	10.10.1.1	10.10.1.10	9898	DISABLED	0	DISABLED	0	Connected

```
-----
```

Verifying the GQI Configuration

To verify the GQI connection, use the **show cable video gqi connection** command, as shown in the following example:

```
Router>show cable video gqi connection
```

```
-----
```

LED ID	Management IP	Server IP	Connection Status	Version	Event Pending	Reset Indication	Encryption Discovery
2	10.10.1.1	10.100.1.1	Connected	2	0	ACKED	Sent

```
-----
```

To verify the statistics of GQI, use the **show cable video logical-edge-device id <ID> statistics** command, as shown in the following example:

```
Router>show cable video logical-edge-device id <ID> statistics
```

	Create Session	Delete Session	Insert Packet	Cancel Packet	Switch Source	Reset Indication	Encryption Discovery	Event Notification
Success	4	0	0	0	0	3	7	0
Error	0	0	0	0	0	0	0	0
Total	4	0	0	0	0	3	7	0

Verifying the GQI Sessions for Encryption

To verify whether the sessions are encrypted, use the **show cable video session logical-edge-device id <ID> command**, as shown in the following example, and check the **Encrypt Status** field.

```
Router>show cable video session logical-edge-device id <ID>
```

Total Sessions = 4

Session Output Id	Output Input Port	Streaming Output Type	Session Encrypt Type	Session Encrypt Ucast	Source Dest IP/Mcast Latency Name	UDP Session IP (S,G) Port	Output Program State	Input State	State
1048580	20 1713128	Passthru 1698122 CLEAR	UDP -	10.10.10.11 N		49152 -	-	ACTIVE-PSI	ON
1048581	20 1711859	Remap 1707422 DVB	UDP Encrypted	10.10.10.11 N		49153 2	0x00000000000000000001	ACTIVE-PSI	ON
1048582	23 1711962	Passthru 1699101 CLEAR	UDP -	10.10.10.11 N		49154 -	0x00000000000000000002	ACTIVE-PSI	ON
1048583	23 1712498	Remap 1707834 DVB	UDP Encrypted	10.10.10.11 N		49155 4	0x00000000000000000003	ACTIVE-PSI	ON
						49155 4	0x00000000000000000004	ACTIVE-PSI	ON

The session's **Encrypt Status** should be **Encrypted**. The **Output State** should be **ON** to show the proper **Encrypt Status** for **DVB** sessions. If the **Output State** is **Pending**, the **Encrypt Status** will be shown as **Pending**.

To get a list of SCGs, use the **show cable video scg allq** command as shown in the following example:

```
Router>show cable video scg allq
```

SCGs: 4 Carriers with SCGs: 3

SCG ID	ON ID	TS ID	SCG Ref ID	Activation Time	CP Duration (msec)	SCG Status	Sess Id	LED/ EIS
900	1	20	65535	Immediate	10000	Active	N/A	1
	Service IDs : 2 ES PIDs : NA							
9001	1	20	65535	Immediate	10000	Active	N/A	1
	Service IDs : 1 ES PIDs : NA							
9006	1	22	65535	Immediate	10000	Active	N/A	1
	Service IDs : 1 ES PIDs : NA							
9002	1	23	65535	Immediate	10000	Active	N/A	1
	Service IDs : 4 ES PIDs : NA							

Number of SCGs = 4

Verifying ONID and TSID of the QAMs Configured for Specific LED

To get the details of ONID and TSID configured for QAMs configured under LED, use the **show cable video logical-edge-device id 1**, as shown in the following example, and verify the ONID and TSID details:

```

Logical Edge Device: led1
Id: 1
Protocol: GQI
Service State: Active
Discovery State: Disable
Management IP: 10.10.10.11
MAC Address:
Number of Servers: 1
  Server 1: 10.10.10.11
Reset Interval: 5
Keepalive Interval: 5   Retry Count:3
Number of Virtual Carrier Groups: 1
Number of Share Virtual Edge Input: 1
Number of Physical Qams: 39
Number of Sessions: 4
No Reserve PID Range

Virtual Edge Input:
Input Port   VEI           Slot/Bay      Bundle        Gateway
ID           IP
-----
1            10.10.10.11  7/0          -             -

Virtual Carrier Group:
ID Name      Total Total      Service-Distribution-Group Service-Distribution-Group
VEI         RF-channel Name                               ID
-----
1  vcg1 0     39         sdg1                               1

QAM          Port   Physical Admin Operational TSID ONID Output VCG SDG Encryption
Controller  Type   QAM ID  State  State          ID  ONID  Port  ID  ID  Capable
-----
7/0/0:0     RF Port 0      ON  UP      1  1  1  1  1  dualcrypt
7/0/0:1     RF Port 1      ON  UP      2  1  2  1  1  dualcrypt
7/0/0:2     RF Port 2      ON  UP      3  1  3  1  1  dualcrypt
7/0/0:3     RF Port 3      ON  UP      4  1  4  1  1  dualcrypt
7/0/0:4     RF Port 4      ON  UP      5  1  5  1  1  dualcrypt
7/0/0:5     RF Port 5      ON  UP      6  1  6  1  1  dualcrypt
7/0/0:6     RF Port 6      ON  UP      7  1  7  1  1  dualcrypt
7/0/0:7     RF Port 7      ON  UP      8  1  8  1  1  dualcrypt
7/0/0:8     RF Port 8      ON  UP      9  1  9  1  1  dualcrypt
7/0/0:9     RF Port 9      ON  UP     10  1 10  1  1  dualcrypt
7/0/0:10    RF Port 10     ON  UP     11  1 11  1  1  dualcrypt
7/0/0:20    RF Port 20     ON  UP     20  1 20  1  1  dualcrypt
7/0/0:21    RF Port 21     ON  UP     21  1 21  1  1  dualcrypt
7/0/0:22    RF Port 22     ON  UP     22  1 22  1  1  dualcrypt
7/0/0:23    RF Port 23     ON  UP     23  1 23  1  1  dualcrypt
7/0/0:24    RF Port 24     ON  UP     24  1 24  1  1  dualcrypt
7/0/0:25    RF Port 25     ON  UP     25  1 25  1  1  dualcrypt
7/0/0:26    RF Port 26     ON  UP     26  1 26  1  1  dualcrypt
7/0/0:27    RF Port 27     ON  UP     27  1 27  1  1  dualcrypt
7/0/0:28    RF Port 28     ON  UP     28  1 28  1  1  dualcrypt
7/0/0:29    RF Port 29     ON  UP     29  1 29  1  1  dualcrypt

```

7/0/0:30	RF Port 30	ON	UP	30	1	30	1	1	dualcrypt
7/0/0:31	RF Port 31	ON	UP	31	1	31	1	1	dualcrypt
7/0/0:32	RF Port 32	ON	UP	32	1	32	1	1	dualcrypt
7/0/0:33	RF Port 33	ON	UP	33	1	33	1	1	dualcrypt
7/0/0:34	RF Port 34	ON	UP	34	1	34	1	1	dualcrypt
7/0/0:35	RF Port 35	ON	UP	35	1	35	1	1	dualcrypt
7/0/0:36	RF Port 36	ON	UP	36	1	36	1	1	dualcrypt
7/0/0:37	RF Port 37	ON	UP	37	1	37	1	1	dualcrypt
7/0/0:38	RF Port 38	ON	UP	38	1	38	1	1	dualcrypt
7/0/0:39	RF Port 39	ON	UP	39	1	39	1	1	dualcrypt
7/0/0:40	RF Port 40	ON	UP	40	1	40	1	1	dualcrypt
7/0/0:41	RF Port 41	ON	UP	41	1	41	1	1	dualcrypt
7/0/0:42	RF Port 42	ON	UP	42	1	42	1	1	dualcrypt
7/0/0:43	RF Port 43	ON	UP	43	1	43	1	1	dualcrypt
7/0/0:44	RF Port 44	ON	UP	44	1	44	1	1	dualcrypt
7/0/0:45	RF Port 45	ON	UP	45	1	45	1	1	dualcrypt
7/0/0:46	RF Port 46	ON	UP	46	1	46	1	1	dualcrypt
7/0/0:47	RF Port 47	ON	UP	47	1	47	1	1	dualcrypt

Troubleshooting Tips

If some configuration errors occur, see the following troubleshooting tips:

- The Management IP must be unique and in the subnet of virtual port group.
- Ensure that the ECMG Server is pingable with source interface as the virtual port group from the Cisco cBR-8 console. This indicates that the ECMG Server is reachable and route is valid.
- Ensure that the TCP port number configured for the ECMG Server in the Cisco cBR-8 is the same as that of the ECMG Server listening port.
- Ensure that the management IP is pingable from the EIS Server. Otherwise, check the routing between the cBR-8 chassis and the EIS server.
- Ensure that the listening port that is configured for the EIS is used for establishing the connection from the EIS Server.
- Ensure that the Virtual Port Group interface is active.
- Ensure that the TenGigabitEthernet interface using which the management traffic reaches the Cisco cBR-8 and the interface through which the CA interface route is configured are active.
- Ensure that the GQI connection is active and sessions are available to be set up.
- Ensure that the EIS connection is active and SCG is available in Cisco cBR-8 .
- Ensure that the CAS configured for ECMG matches the ECM group in SCG.
- Ensure that the ONID, TSID, and Program Number are synchronized with the configured sessions and SCG.

Configuration Examples

This section provides examples for configuring DualCrypt Encryption Mode:

Example: Basic Session-based Scrambling Configuration

```

cable video
mgmt-intf VirtualPortGroup 0
encryption
linecard 8/0 ca-system dualcrypt scrambler dvb-csa
dvb
route-ecmg 10.10.10.11 255.255.255.224 Port-channel26 2.26.1.2
mgmt-ip 10.10.10.11
eis test id 1
    listening-port 9898
ca-interface linecard 8/0 10.10.10.12
ecmg test id 1
mode vod linecard 8/0
type standard
ca-system-id 950 0
auto-channel-id
ecm-pid-source sid
connection id 1 priority 1 10.10.10.13 9878
service-distribution-group sdg1 id 1
    rf-port integrated-cable 8/0/0
virtual-carrier-group vcg1 id 1
encrypt
service-type narrowcast
rf-channel 20-47 tsid 20-47 output-port-number 20-47
bind-vcg
vcg vcg1 sdg sdg1
logical-edge-device led1 id 1
protocol gqi
mgmt-ip 10.10.10.10
server 10.100.10.11
virtual-edge-input-ip 10.10.10.11 input-port-number 1
vcg vcg1
active

```

Example: Session-based Configuration with EIS Binding to LED using LED ID

```

cable video
mgmt-intf VirtualPortGroup 0
encryption
linecard 8/0 ca-system dualcrypt scrambler dvb-csa
dvb
route-ecmg 10.10.10.11 255.255.255.224 Port-channel26 10.10.10.10
mgmt-ip 10.10.10.13
eis test id 1
    listening-port 9898 bind led id 1
ca-interface linecard 8/0 10.10.10.14
ecmg test id 1
mode vod linecard 8/0
type standard
ca-system-id 950 0
auto-channel-id
ecm-pid-source sid
connection id 1 priority 1 10.10.10.11 9878
service-distribution-group sdg1 id 1
onid 1
rf-port integrated-cable 8/0/0
virtual-carrier-group vcg1 id 1
encrypt
service-type narrowcast
rf-channel 20-47 tsid 20-47 output-port-number 20-47
bind-vcg
vcg vcg1 sdg sdg1

```

Example: Configuration with EIS Binding to LED using LED Name

```

logical-edge-device led1 id 1
protocol gqi
mgmt-ip 10.10.10.11
server 10.10.10.112
virtual-edge-input-ip 10.10.10.11 input-port-number 1
vcg vcg1
active

```

Example: Configuration with EIS Binding to LED using LED Name

```

cable video
mgmt-intf VirtualPortGroup 0
encryption
linecard 8/0 ca-system dualcrypt scrambler dvb-csa
dvb
route-ecmg 10.10.10.11 255.255.255.224 Port-channel26 10.10.10.11
mgmt-ip 10.10.10.11
eis test id 1
  listening-port 9898 bind led name led1
ca-interface linecard 8/0 10.10.10.11
ecmg test id 1
mode vod linecard 8/0
type standard
ca-system-id 950 0
auto-channel-id
ecm-pid-source sid
connection id 1 priority 1 10.10.10.11 9878
service-distribution-group sdg1 id 1
onid 1
rf-port integrated-cable 8/0/0
virtual-carrier-group vcg1 id 1
encrypt
service-type narrowcast
rf-channel 20-47 tsid 20-47 output-port-number 20-47
bind-vcg
  vcg vcg1 sdg sdg1
logical-edge-device led1 id 1
protocol gqi
mgmt-ip 10.10.10.11
server 10.10.10.112
virtual-edge-input-ip 10.10.10.11 input-port-number 1
vcg vcg1
active

```

Example: EIS Binding to IP Address Other than Default DVB Management IP Address

```

cable video
mgmt-intf VirtualPortGroup 0
encryption
linecard 8/0 ca-system dualcrypt scrambler dvb-csa
dvb
route-ecmg 10.10.10.11 255.255.255.224 Port-channel26 10.10.10.11
mgmt-ip 10.10.10.11
eis test id 1
  listening-port 9898 bind ip 10.10.10.11
ca-interface linecard 8/0 10.10.10.11
ecmg test id 1
  mode vod linecard 8/0
  type standard
  ca-system-id 950 0
  auto-channel-id
  ecm-pid-source sid
  connection id 1 priority 1 10.10.10.11 9878

```



```

service-distribution-group sdg1 id 1
onid 1
rf-port integrated-cable 8/0/0
virtual-carrier-group vcg1 id 1
encrypt
service-type narrowcast
rf-channel 20-47 tsid 20-47 output-port-number 20-47
bind-vcg
    vcg vcg1 sdg sdg1
logical-edge-device led1 id 1
protocol gqi
mgmt-ip 10.10.10.11
server 10.10.10.11
virtual-edge-input-ip 10.10.10.11 input-port-number 1
vcg vcg1
active

```

Example: Session-based Configuration with VRF

```

cable video
multicast-uplink Loopback410 access-list all-multicast vrf vrf_script_red_1 next-hop
10.10.10.11
mgmt-intf VirtualPortGroup 0
encryption
    linecard 1/0 ca-system dvb scrambler dvb-csa
    dvb
        route-ecmg 10.10.10.11 255.255.255.224 Port-channel21 10.10.10.1
        route-ecmg 10.10.10.16 255.255.255.224 Port-channel21 10.10.10.1
        mgmt-ip 10.10.10.10
        eis pytool1 id 1
            listening-port 2500
            cp-override 6
            overwrite-scg
        ca-interface linecard 1/0 10.10.10.0 vrf vrf_script_red_1
        emcg emcg1 id 1
            mode vod linecard 1/0
            type standard
            ca-system-id 952 0
            auto-channel-id
            ecm-pid-source sid
            connection id 1 priority 1 10.10.10.11 5678
            connection id 2 priority 1 10.10.10.16 8765
        emcg emcg2 id 2
            mode vod linecard 1/0
            type standard
            ca-system-id 951 0
            auto-channel-id
            ecm-pid-source sid
            connection id 1 priority 1 10.10.10.14 8765
        emcg emcg3 id 3
            mode vod linecard 1/0
            type standard
            ca-system-id 950 0
            auto-channel-id
            ecm-pid-source sid
            connection id 1 priority 1 10.10.10.11 5678

interface VirtualPortGroup0
vrf forwarding vrf_script_red_1
ip address 10.10.10.11 255.255.224.0
no mop enabled
no mop sysid

```

Feature Information for DualCrypt Encryption Mode

Table 22: Feature Information for DualCrypt Encryption Mode

Feature Name	Releases	Feature Information
DualCrypt Encryption Mode	Cisco IOS XE Everest 16.5.1	This feature was integrated on the Cisco cBR Series Converged Broadband Routers.



CHAPTER 22

Low Latency VOD Support

The Cisco cBR-8 router supports Low Latency Video on Demand (VOD) sessions for gaming.

Contents

- [Information About Low Latency VOD Support, on page 149](#)
- [How to Configure Low Latency VOD Support, on page 150](#)
- [Feature Information for Low Latency VOD Support, on page 153](#)

Information About Low Latency VOD Support

Overview of Low Latency VOD Support

Each Cisco cBR-8 RF linecard supports up to 1280 low latency VOD gaming sessions and up to 64 unique low latency QAMs. These numbers are applicable to both Annex A and B.

An output QAM is treated as low latency if it is associated with a virtual carrier group (VCG) that is configured as low-latency.

A table-based input session is treated as low latency if the session jitter ≤ 50 ms and output QAM is low latency.

A GQI input session is treated as low latency if the session type is gaming and output QAM is low latency.

Low latency VOD gaming, normal VOD, and Switched Digital Video (SDV) can share the same low latency QAM.

Each Cisco cBR-8 RF linecard supports up to 384 unique normal latency Annex B video QAMs (288 Annex A). Each QAM used for low latency reduces the number of remaining available QAMs by two. For example, the linecard can support up to 256 normal latency and 64 low latency Annex B QAMs.

The average latency of a low latency session is approximately 13 ms plus 50% of the jitter buffer size.

How to Configure Low Latency VOD Support

Configuring the Low Latency Virtual Carrier Group

To configure the low latency virtual carrier group, follow the steps below:

```
enable
configure terminal
cable video
virtual-carrier-group id
low-latency
```

If more than 64 low latency QAM channels are being configured, CLI will output the following error:

```
%ERROR: Number of low latency QAM channels configured has reached the linecard limit.
```

If a QAM is configured for low latency, it cannot be configured for broadcast and vice versa, CLI will output the following errors:

```
%ERROR: Failed to set low latency to virtual group.
Reason: Broadcast service type is set and cannot set low latency.
```

```
%ERROR: Failed to set_svctype to virtual group.
Reason: Low latency is set and cannot set service type to broadcast.
```

Verifying the Low Latency Virtual Carrier Group Configuration

To verify the configuration of the low latency virtual carrier group, use the **show cable video virtual-carrier-group** command as shown in the example below:

```
Router# show cable video virtual-carrier-group id 1
Name: vcg1
  ID: 1
  Service Distribution Group Name: sdg1
  Service Distribution Group ID: 1
  Logical Edge Device Name: led1
  Logical Edge Device ID: 1
  ServiceType: narrowcast
  Encrypted: N
  Low Latency: Y
  Number of VEIs: 0
  Virtual Edge Input:
  Input Port   VEI           Bundle
  ID           IP             ID
  -----
  Number of RF-Channels: 8
  RF-Channel Range  TSID Range  Output Port Number Range
  -----
  0-7                100-107     100-107
```

Verifying the Low Latency in Linecard

To verify the low latency configuration in the linecard, use the **show cable video low-latency linecard** command as shown in the example below:

```

Router# show cable video low-latency linecard all
Line Card: 1
  Virtual-Carrier-Group: vcg1
  Service-Distribution-Group: sdg1
  Logical-Edge-Device: led1
  Number of RF-Channels: 8
  RF-Channel Range   TSID Range   Output Port Number Range
  -----
  0-7                100-107     100-107

Line Card: 2
  Virtual-Carrier-Group: vcg2
  Service-Distribution-Group: sdg2
  Logical-Edge-Device: led1
  Number of RF-Channels: 8
  RF-Channel Range   TSID Range   Output Port Number Range
  -----
  0-7                200-207     200-207

```

Configuring the Jitter Buffer Size for Table Based Session

To configure the jitter buffer size for table-based session, follow the steps below:

```

enable
configure terminal
cable video
table-based
vcg vcg_name
rf-channel start_rf_channel-end_rf_channel
session session_name input-port input_port_number start-udp-port
unicast_udp_port_number num-sessions-per-qam max_sessions_per_qam_channel
processing-type [data|passthru|remap|remux] start-program program_number
jitter jitter_value

```

The default jitter buffer size for table-based video is 100 ms.

Configuring the Jitter Buffer Size for GQI

To configure the jitter buffer size for GQI session, follow the steps below:

```

enable
configure terminal
cable video
jitter session_type jitter_value

```

Verifying Jitter Buffer Size for GQI

To verify the jitter buffer size for GQI session, use the **show cable video jitter** command as shown in the example below:

```

Router# show cable video jitter
Session jitter:
  VOD: 200
  SDV: 200
  broadcast: 200

```

```
gaming: 5
table-based: 100
```

Verifying the Low Latency Sessions

To verify the configuration of the low latency session, use the **show cable video session logical-edge-device** command as shown in the example below:

```
Router# show cable video session logical-edge-device id 1
Total Sessions = 160
```

Session Id	Output State	Output Port	Streaming Output Type	Streaming Output Bitrate	Session Encrypt Type	Session Encrypt Status	Session Source Ucast Dest IP/Mcast Latency Name	UDP Port	Output Program	Input State
1048576	100		Remap		UDP	-	174.101.1.1	49152	1	ACTIVE-PSI
ON	1723787	1722987	CLEAR		-	Y	t1.1.0.1.0.49152			
1048577	100		Remap		UDP	-	174.101.1.1	49153	2	ACTIVE-PSI
ON	1724147	1722987	CLEAR		-	Y	t1.1.0.1.0.49153			
1048578	100		Remap		UDP	-	174.101.1.1	49154	3	ACTIVE-PSI
ON	1722807	1722987	CLEAR		-	Y	t1.1.0.1.0.49154			
1048579	100		Remap		UDP	-	174.101.1.1	49155	4	ACTIVE-PSI
ON	1723279	1722987	CLEAR		-	Y	t1.1.0.1.0.49155			
1048580	100		Remap		UDP	-	174.101.1.1	49156	5	ACTIVE-PSI
ON	1723665	1722987	CLEAR		-	Y	t1.1.0.1.0.49156			
1048581	100		Remap		UDP	-	174.101.1.1	49157	6	ACTIVE-PSI
ON	1724096	1722987	CLEAR		-	Y	t1.1.0.1.0.49157			
1048582	100		Remap		UDP	-	174.101.1.1	49158	7	ACTIVE-PSI
ON	1724475	1722987	CLEAR		-	Y	t1.1.0.1.0.49158			
1048583	100		Remap		UDP	-	174.101.1.1	49159	8	ACTIVE-PSI
ON	1723166	1722988	CLEAR		-	Y	t1.1.0.1.0.49159			
1048584	100		Remap		UDP	-	174.101.1.1	49160	9	ACTIVE-PSI
ON	1723595	1722988	CLEAR		-	Y	t1.1.0.1.0.49160			
1048585	100		Remap		UDP	-	174.101.1.1	49161	10	ACTIVE-PSI
ON	1724024	1722988	CLEAR		-	Y	t1.1.0.1.0.49161			
1048586	100		Remap		UDP	-	174.101.1.1	49162	11	ACTIVE-PSI
ON	1724425	1722988	CLEAR		-	Y	t1.1.0.1.0.49162			
1048587	100		Remap		UDP	-	174.101.1.1	49163	12	ACTIVE-PSI
ON	1723547	1722989	CLEAR		-	Y	t1.1.0.1.0.49163			
1048588	100		Remap		UDP	-	174.101.1.1	49164	13	ACTIVE-PSI
ON	1722215	1722988	CLEAR		-	Y	t1.1.0.1.0.49164			
1048589	100		Remap		UDP	-	174.101.1.1	49165	14	ACTIVE-PSI
ON	1722683	1722988	CLEAR		-	Y	t1.1.0.1.0.49165			
1048590	100		Remap		UDP	-	174.101.1.1	49166	15	ACTIVE-PSI
ON	1723060	1723001	CLEAR		-	Y	t1.1.0.1.0.49166			

--More--

Feature Information for Low Latency VOD Support

Table 23: Feature Information for Low Latency VOD Support

Feature Name	Releases	Feature Information
Low Latency VOD Support	Cisco IOS XE Everest 16.5.1	This feature was integrated on the Cisco cBR Series Converged Broadband Routers.



CHAPTER 23

Video MIBs

The SCTE-HMS-MPEG-MIB and SCTE-HMS-QAM-MIB are supported under the video management framework of Cisco cBR-8 routers.

- [SCTE-HMS-MPEG-MIB, on page 155](#)
- [SCTE-HMS-QAM-MIB, on page 156](#)

SCTE-HMS-MPEG-MIB

SCTE-HMS-MPEG-MIB MIB module represents the MPEG equipment in the headend. It defines both the MPEG input and output MIB objects for managing MPEG input and output transport streams, programs and elementary streams. It provides both input and output related statistics, as well as program mapping and video session information. It includes the following tables:

mpegInputTSEntry

Provides the details of input transport stream to a video session.

mpegInputProgEntry

Describes the PSI of each incoming program.

mpegProgESEntry

Contains information about the elementary streams in a program.

mpegInputStatsEntry

Each entry in this table describes statistics for each input transport stream.

mpegInputUdpOriginationEntry

Specifies the UDP unicast or multicast flows of an input transport stream. For unicast streams, it represents the UDP port and optionally destination IP address of the input transport stream origination UDP IP flow. For multicast streams, it represents the set of SSM multicast groups of the input transport stream origination UDP IP flow.

mpegInsertPacketEntry

Describes packet insertion information. Typical packets that are inserted at the RF output of a device are PSI, PSIP, and CVCT MPEG packets. These packets have their own PID. This table may be empty if the video device does not support packet insertion or does not have any packet insertion configured.

mpegOutputStatsEntry

Specifies the diagnostic statistics objects for the output transport stream of an MPEG device.

mpegOutputTSEntry

Specifies the attributes of an outgoing transport stream SPTS or MPTS.

mpegOutputProgEntry

Describes the PSI of each outgoing program.

mpegOutputProgElemStatsEntry

Contains the statistical information associated with the elementary streams of an MPEG program.

mpegOutputUdpDestinationEntry

Specifies the UDP unicast or multicast of the output transport stream this entry references.

mpegProgramMappingEntry

Describes program mappings, i.e., ties the input destination to the output destination for every active program in the device.

mpegVideoSessionEntry

Stores video session information. The session type is VOD, SDV or DB. It captures logical information about a video stream, such as source and destination addresses, UDP port etc., and also ties this information with direct mapping of input and output programs.

mpegVideoSessionPtrEntry

Provides a quick reference of the program mapping and input/output transport stream connection information associated with a video session.

mpegInputTSOutputSessionEntry

Specifies the list of output session indexes that the input transport stream entry is feeding. For unicast sessions, it typically points to just one output session. For multicast sessions, it points to all the output sessions using this internally replicated input transport stream.

SCTE-HMS-QAM-MIB

SCTE-HMS-QAM-MIB represents edge QAM equipment present in the headend. It defines QAM channel related configuration MIB objects associated with physical and logical characteristics of the QAM channel. It includes the following tables:

qamChannelTable

Describes the configuration and attribution of each QAM channel designated by ifIndex.

qamChannelCommonTable

Describes QAM channel output bandwidth and utilization information designation by ifIndex.

qamConfigTable

Contains the following parameters for a range of QAM Channels:

- IP addresses configuration for the QAM channels (VEI IP Addresses)
- Program number range associated with QAM channels (constant in Cisco cBR-8 routers)
- UDP port range (constant in Cisco cBR-8 routers)

