



Cisco DOCSIS 3.0 Downstream Solution Design and Implementation Guide

September 2014

Cisco Systems, Inc.
www.cisco.com

Cisco has more than 200 offices worldwide.
Addresses, phone numbers, and fax numbers
are listed on the Cisco website at
www.cisco.com/go/offices.

THE SPECIFICATIONS AND INFORMATION REGARDING THE PRODUCTS IN THIS MANUAL ARE SUBJECT TO CHANGE WITHOUT NOTICE. ALL STATEMENTS, INFORMATION, AND RECOMMENDATIONS IN THIS MANUAL ARE BELIEVED TO BE ACCURATE BUT ARE PRESENTED WITHOUT WARRANTY OF ANY KIND, EXPRESS OR IMPLIED. USERS MUST TAKE FULL RESPONSIBILITY FOR THEIR APPLICATION OF ANY PRODUCTS.

THE SOFTWARE LICENSE AND LIMITED WARRANTY FOR THE ACCOMPANYING PRODUCT ARE SET FORTH IN THE INFORMATION PACKET THAT SHIPPED WITH THE PRODUCT AND ARE INCORPORATED HEREIN BY THIS REFERENCE. IF YOU ARE UNABLE TO LOCATE THE SOFTWARE LICENSE OR LIMITED WARRANTY, CONTACT YOUR CISCO REPRESENTATIVE FOR A COPY.

The Cisco implementation of TCP header compression is an adaptation of a program developed by the University of California, Berkeley (UCB) as part of UCB's public domain version of the UNIX operating system. All rights reserved. Copyright © 1981, Regents of the University of California.

NOTWITHSTANDING ANY OTHER WARRANTY HEREIN, ALL DOCUMENT FILES AND SOFTWARE OF THESE SUPPLIERS ARE PROVIDED "AS IS" WITH ALL FAULTS. CISCO AND THE ABOVE-NAMED SUPPLIERS DISCLAIM ALL WARRANTIES, EXPRESSED OR IMPLIED, INCLUDING, WITHOUT LIMITATION, THOSE OF MERCHANTABILITY, FITNESS FOR A PARTICULAR PURPOSE AND NONINFRINGEMENT OR ARISING FROM A COURSE OF DEALING, USAGE, OR TRADE PRACTICE.

IN NO EVENT SHALL CISCO OR ITS SUPPLIERS BE LIABLE FOR ANY INDIRECT, SPECIAL, CONSEQUENTIAL, OR INCIDENTAL DAMAGES, INCLUDING, WITHOUT LIMITATION, LOST PROFITS OR LOSS OR DAMAGE TO DATA ARISING OUT OF THE USE OR INABILITY TO USE THIS MANUAL, EVEN IF CISCO OR ITS SUPPLIERS HAVE BEEN ADVISED OF THE POSSIBILITY OF SUCH DAMAGES.

Cisco and the Cisco logo are trademarks or registered trademarks of Cisco and/or its affiliates in the U.S. and other countries. To view a list of Cisco trademarks, go to this URL: www.cisco.com/go/trademarks. Third-party trademarks mentioned are the property of their respective owners. The use of the word partner does not imply a partnership relationship between Cisco and any other company. (1110R)

Any Internet Protocol (IP) addresses used in this document are not intended to be actual addresses. Any examples, command display output, and figures included in the document are shown for illustrative purposes only. Any use of actual IP addresses in illustrative content is unintentional and coincidental.

Cisco DOCSIS 3.0 Downstream Channel Bonding Solution Design and Implementation Guide
©2007-2010, 2014 Cisco Systems, Inc. All rights reserved.



1

Preface 11

CHAPTER 1 Overview for Cisco DOCSIS 3.0 Downstream Solution 11

- Overview 11
- Cisco DOCSIS 3.0 M-CMTS Solution 12
- Cisco DOCSIS 3.0 I-CMTS Solution 12

CHAPTER 3 Cisco DOCSIS 3.0 Downstream Solution Overview for the Cisco M-CMTS 13

- Description and Scope 13
 - Compatibility with Prior Versions of DOCSIS 14
 - Cisco DOCSIS 3.0 Solution Capabilities 14
- Architecture and Scope 15
 - Cisco DOCSIS 3.0 DS Solution Scope 16
 - Out of Scope 17
- Cisco DOCSIS 3.0 DS Solution Key Features 17
- Cisco DOCSIS 3.0 DS Solution Components 110
 - Cisco and Scientific Atlanta Equipment 110
 - Third-Party Equipment 111

CHAPTER 13 Cisco DOCSIS 3.0 Downstream Solution Overview for the I-CMTS 113

- Description and Scope 113
- Architecture and Scope 113
 - In Scope 114
 - Out of Scope 115
- Cisco DOCSIS 3.0 Downstream Solution Key Features 115
- Cisco DOCSIS 3.0 Downstream Solution Components 116

CHAPTER 1 Cisco DOCSIS 3.0 Downstream Solution Components 11

- Base CMTS Components 11
 - Base CMTS Component Requirements 14
 - Cable Interface Line Cards and Network Uplink Line Cards 17
- Wideband CMTS Components 19

Wideband SIP and Wideband SPA	19
Cisco Wideband SIP	110
Cisco Wideband SPA	110
Cisco 6 Gbps Wideband Shared Port Adapter	110
Cisco 3 Gbps Wideband Shared Port Adapter	111
External Edge QAM Device	112
Number of EQAM Devices Required	112
Cisco RF Gateway 1	113
Cisco RF Gateway 10	113
Harmonic NSG 9000	114
Gigabit Ethernet Switch (Optional)	114
DOCSIS Timing Interface Server	114
Symmetricom TimeCreator 1000	115
Wideband Cable Modems	115
Scientific Atlanta DPC3010 Wideband Cable Modem	116
Linksys WCM300 Wideband Cable Modem	116
Scientific Atlanta DPC2505 and EPC2505 Wideband Cable Modems	117
Wideband CMTS Redundancy and Resiliency	117
Route Processor Redundancy and Resiliency	118
Route Processor Redundancy Plus	119
DOCSIS Stateful Switchover	119
Cisco uBR10-MC5X20 Line Card Redundancy	119
Cisco uBR-MC3GX60V Line Card Redundancy	120
Cisco uBR-MC3GX60V Line Card Redundant Gigabit Ethernet Ports	120
Wideband SPA Redundancy	121
Wideband SPA Redundant Gigabit Ethernet Ports	121
Wideband Channel Resiliency	121
Edge QAM Redundancy	121
Edge QAM Redundant Gigabit Ethernet Ports	122
Where to Find Information on Solution Hardware Components	122
CHAPTER 41	
Cisco DOCSIS 3.0 Downstream Solution Architecture	141
Modular CMTS	141
Benefits of M-CMTS Architecture	145
Cost-Effective Architecture	145
Multiservice Architecture	145
GE Switch Functionality	146
DOCSIS Timing Interface Server Functionality	146
Edge QAM Device Functionality	147

Integrated CMTS	147
Benefits of I-CMTS Architecture	148
Wideband Cable Modem Functionality	148
Wideband Cable Modem Design and Operation	149
Cisco DOCSIS 3.0 DS Solution	149
Primary-Capable Downstream Channels	151
Extensible MAC Domain Support Through Channel Grouping Domain	152
Virtual Bundle Support for Modular Cable Interfaces	154
CMTS Interfaces Associated With a Cable Modem	154
Fiber node	155
Enhanced M-CMTS Channel Support	156
Load Balancing Support for DOCSIS 1.x or DOCSIS 2.0 Modems on SPA RF Channels	157
Legacy Feature Support	158
Primary-Capable Downstream Channel Selection	159
High Availability Support for Cable Modems on SPA DS Channels	161
DOCSIS 3.0 Wideband Channel Support	162
Security	165
Quality of Service	165
Support for Cisco SIP-600 and Gigabit Ethernet SPAs	165
Wideband Modem Resiliency	166
Dynamic Bandwidth Sharing	166
DOCSIS WFQ Scheduler	167
Voice Support on Wideband Modems	167
DOCSIS 3.0 Downstream Bonding for Bronze Certification	168
CHAPTER 69	
Implementing and Configuring the Solution	169
Wideband CMTS Configuration	169
Configuring Base CMTS Components	169
Configuring Wideband CMTS Components	171
Configuring a Wideband Capable Line Card	171
Configuring M-CMTS Components	173
Wideband Cable Modem Behavior	177
Cisco DPC3010	177
Cisco DPC3000	177
Linksys WCM300-NA, WCM300-EURO, and WCM300-JP Modems	177
DOCSIS Configuration File for Wideband on Linksys WCM300 Modems	178
Scientific Atlanta DPC2505 and EPC2505 Wideband Cable Modems	180
CMTS Interactions with Wideband Modems	180
Registration for Wideband Modems	180

- Automatic Adjustments During Registration 181
- Registration Load Balancing for Wideband Modems 181
- Cisco SIP-600 and Gigabit Ethernet SPA Configuration 182
 - Configuring the Cisco SIP-600 182
 - Configuring the Gigabit Ethernet SPAs 182
- Supported MIBs 182
- Known Restrictions 184
 - Cisco Wideband SPA Restrictions 184
 - Cisco SIP-600 Restrictions 184
 - Gigabit Ethernet SPA Restrictions 184
 - Cisco uBR-MC3GX60V Line Card Restrictions 185

CHAPTER 1

Monitoring and Troubleshooting Narrowband and Wideband Components 11

- Monitoring Narrowband and Wideband Components 11
 - Monitoring Wideband Line Cards 12
 - show diag for Wideband SIPs 12
 - show diag for the Cisco uBR-MC3GX60V Line Card 13
 - show hw-module bay oir 14
 - show diag for Wideband SPA 14
 - show controllers modular-cable for Cisco uBR-MC3GX60V Line Card 15
 - show controllers modular-cable <controller> sfp for Cisco uBR-MC3GX60V Line Card 18
 - show controllers modular-cable for Wideband SPA 19
 - show controllers cable 111
 - Monitoring Wideband Channels 114
 - show interface wideband-cable 114
 - show hw-module bay and show controller 116
 - Monitoring Narrowband RF Channels 118
 - show interface modular-cable and show interface integrated-cable 118
 - show hw-module bay 119
 - show controller modular-cable and show controller integrated-cable 120
 - Monitoring Voice Services 122
 - Monitoring Narrowband and Wideband Cable Modems 123
 - show cable modem wideband 123
 - show cable modem summary 124
 - show cable modem primary 125
 - show cable modem primary-channel 125
 - show cable modem voice 125
 - Monitoring Cable MAC Domains 125
 - show cable mac-domain downstream-service-group 125

show cable mac-domain cgd-associations	126
Troubleshooting Wideband Components	126
Troubleshooting Power Up Issues	127
Performing Basic Power Troubleshooting on a Wideband SIP and Wideband SPA	128
Performing Basic Power Troubleshooting on the Cisco uBR-MC3GX60V Line Card	128
Troubleshooting DOCSIS Timing and Control Card	129
Verifying Active DTCC and Status	129
Verifying DTI Counters	130
Verifying DTI Clock Synchronization	130
Troubleshooting EQAM Connectivity Issues of the M-CMTS	131
Verifying the Up State of an Active Gigabit Ethernet Port of a Wideband SPA	131
Verifying the Up State of an Active Gigabit Ethernet Port of a Cisco uBR-MC3GX60V Line Card	132
Verifying Layer 3 Connectivity to the EQAM	132
Troubleshooting Primary-Capable Channel DOCSIS Signalling	133
Verifying MAP, UCD, SYNCs for Primary-Capable Channels	133
Verifying MDD Packet Transmit for DOCSIS 3.0 Operations	134
Troubleshooting Wideband SIP and Wideband SPAs	136
Verifying That a Wideband SPA Is Correctly Configured for SPA-to-EQAM Communications	136
Verifying That a Wideband SPA Is Able to Communicate with the Edge QAM Device	136
Troubleshooting Wideband Channels	137
Verifying That a Wideband Channel Is Up and Is Transmitting Packets	137
Verifying That a Wideband Channel Is Configured Correctly	138
Troubleshooting Wideband Cable Modems	139
Pinging a Wideband Cable Modem	139
Verifying That a Wideband-Capable Cable Modem Is Registered as a Wideband Modem	140
Examining Wideband-Capable Modems That are Partial Online	141
Verifying Other Information for Wideband Cable Modems	141
Troubleshooting Gigabit Ethernet Components	142
Troubleshooting the Cisco SIP-600	142
Troubleshooting the Gigabit Ethernet SPAs	142



Preface

This preface describes the objectives and organization of this document and explains how to find additional information on related products and services. This preface contains the following sections:

- [Document Revision History, page 1](#)
- [Objectives, page 3](#)
- [Document Organization, page 3](#)
- [Conventions, page 6](#)
- [Obtaining Documentation and Submitting a Service Request, page 7](#)

Document Revision History

[Table 1](#) records technical changes to this document.

Table 1 *Document Revision History*

Release No.	Revision	Date	Change Summary
Cisco IOS Release 12.2(33)SCI	—	September 2014	Added information on the Cisco 6 Gbps Wideband Shared Port Adapter
Cisco IOS Release 12.2(33)SCG	OL-10705-07	July 2012	Updated the following chapters to explain support for downstream channel sharing across Cisco uBR-MC3GX60V line card and Cisco Wideband Shared Port Adapters: <ul style="list-style-type: none"> • Chapter 2, “Cisco DOCSIS 3.0 Downstream Solution Overview for the Cisco M-CMTS” • Chapter 5, “Cisco DOCSIS 3.0 Downstream Solution Architecture”
Cisco IOS Release 12.2(33)SCE	OL-10705-06	November 2010	The Cisco DOCSIS 3.0 Downstream solution has been modified to add support for Cisco uBR-MC3GX60V cable interface line card to the Cisco uBR10012 router.
Cisco IOS Release 12.2(33)SCD	OL-10705-05	March 2010	The DOCSIS 3.0 Downstream Channel Bonding feature has been extended to the Cisco uBR7200 series routers

Table 1 **Document Revision History**

Release No.	Revision	Date	Change Summary
Cisco IOS Release 12.3(33)SCB	OL-10705-04	March 2009	<p>The following features have been implemented in this release:</p> <ul style="list-style-type: none"> • DOCSIS 3.0 support for Cisco 10000 SIP-600 SPA Interface Processor. • Support for 5-port Gigabit Ethernet SPA. • Support for 1-port 10 Gigabit Ethernet SPA. • Voice support on wideband (WB) modems for DOCSIS 3.0. • Dynamic Bandwidth Sharing support for DOCSIS 3.0. • Support for DOCSIS 3.0 WQF Scheduler for QoS congestion management. • DOCSIS 3.0 Downstream Bonding for Bronze Certification
Cisco IOS Release 12.3(23)BC	OL-10705-03	December 2007	<p>The following key features have been implemented in this release:</p> <ul style="list-style-type: none"> • Channel bonding of downstream channels from the SPA for DOCSIS 3.0 modem support. • DOCSIS 1.x/2.0 modem support from SPA RF channels. • Primary-capable SPA RF channels used for Mac Management Messages traffic. • Modular-cable interfaces to support narrowband channels. • Concept of Channel Grouping Domain. • RF channel bandwidth sharing between modular-cable and wideband interfaces. • Downstream External PHY Interface (DEPI). • Primary downstream channel selection. • High availability support for cable modems.
Cisco IOS Release 12.3(21a)BC3	OL-10705-02	August 2007	Added information on the Linksys WCM300-NA, WCM300-EURO, WCM300-J modems.
Cisco IOS Release 12.3(21)BC	OL-10705-01	February 2007	First release.

Objectives

This document describes the Cisco DOCSIS 3.0 Downstream Solution for Cisco IOS Release 12.3(23)BC, Cisco IOS Release 12.2(33)SCB, and later releases. It explains how to design and implement a cable network that uses the DOCSIS 3.0 Downstream features.

Document Organization

This document is organized as follows:

Chapter	Title	Description
Chapter 1	Overview for Cisco DOCSIS 3.0 Downstream Solution	Provides an overview of the Cisco DOCSIS 3.0 Downstream Solution.
Chapter 2	Cisco DOCSIS 3.0 Downstream Solution Overview for the Cisco M-CMTS	Provides an overview of the Cisco DOCSIS 3.0 Downstream Solution for the modular cable termination system (M-CMTS).
Chapter 3	Cisco DOCSIS 3.0 Downstream Solution Overview for the I-CMTS	Provides an overview of the Cisco DOCSIS 3.0 Downstream Solution for integrated cable termination system (I-CMTS).
Chapter 4	Cisco DOCSIS 3.0 Downstream Solution Components	Describes the components of the Cisco DOCSIS 3.0 Downstream Solution.
Chapter 5	Cisco DOCSIS 3.0 Downstream Solution Architecture	Explains the Cisco DOCSIS 3.0 Downstream Solution architecture.
Chapter 6	Implementing and Configuring the Solution	Provides implementation and configuration information of the Cisco DOCSIS 3.0 Downstream Solution.
Chapter 7	Monitoring and Troubleshooting Narrowband and Wideband Components	Provides an introduction to monitoring and troubleshooting the narrowband and wideband components of the Cisco DOCSIS 3.0 Downstream Solution.
Appendix A	Cisco DOCSIS 3.0 Downstream Solution, Component Compatibility Matrix	Provides a summary of the component compatibility between the Cisco Wideband Cable Solution, Release 1.0 and Cisco DOCSIS 3.0 Downstream Solution for Cisco IOS Release 12.3(23)BC, Cisco IOS Release 12.2(33)SCB, and releases.

The following is a list of documents and URLs for the Cisco uBR10012 router and the Cisco Wideband SIP and Wideband SPA:

Related Topic	Document Title
Documentation roadmap	<ul style="list-style-type: none"> • <i>Cisco uBR7200 Series Routers and Cisco uBR10012 Universal Broadband Router Documentation Roadmap</i> http://www.cisco.com/en/US/docs/cable/cmts/ubr7200/roadmap/7200rdmp.html
Cisco uBR10012 hardware installation	<ul style="list-style-type: none"> • Cisco uBR10012 Universal Broadband Router SIP and SPA Hardware Installation Guide http://www.cisco.com/en/US/docs/interfaces_modules/shared_port_adapters/install_upgrade/uBR10012/b_10k_sip_spa_hig.html • Cisco uBR10012 Universal Broadband Router Hardware Installation Guide http://www.cisco.com/en/US/docs/cable/cmts/ubr10012/installation/guide/hig.html • <i>Regulatory Compliance and Safety Information for the Cisco uBR10012 Universal Broadband Router</i> http://www.cisco.com/en/US/docs/cable/cmts/ubr10012/regulatory/compliance/ub10rcsi.html • <i>Cisco uBR10012 Universal Broadband Router Performance Routing Engine Module</i> http://www.cisco.com/en/US/docs/interfaces_modules/cable/performance_routing_engine/installation/guide/pre5096.html
Cisco uBR10012 field-replaceable units (FRUs) and fiber-optic maintenance	<ul style="list-style-type: none"> • <i>Cisco uBR10012 Install and Upgrade Guides</i> http://www.cisco.com/en/US/products/hw/cable/ps2209/prod_installation_guides_list.html • For information about cleaning fiber-optic connections, go to the following URL: http://www.cisco.com/en/US/tech/tk482/tk876/technologies_white_paper09186a0080254eba.shtml

Related Topic	Document Title
Cisco uBR10012 software, configuration, and features	<ul style="list-style-type: none"> <li data-bbox="493 260 1521 401">• <i>Cisco uBR10012 Universal Broadband Router SIP and SPA Software Configuration Guide</i> http://www.cisco.com/en/US/docs/interfaces_modules/shared_port_adapters/configuration/ubr10012/b_10k_sip_spa_scg.html <li data-bbox="493 415 1521 527">• <i>Cisco Cable Wideband Solution Design and Implementation Guide, Release 1.0</i> http://www.cisco.com/en/US/docs/cable/cmts/wideband/solution/guide/release_1.0/2component.html <li data-bbox="493 541 1521 682">• Release Notes for Cisco uBR10012 Universal Broadband Router for Cisco IOS Release 12.3 BC http://www.cisco.com/en/US/docs/cable/cmts/ubr10012/release/notes/12_3bc/ubr10k_123bc_rn.html <li data-bbox="493 697 1521 768">• <i>Cisco uBR10012 Universal Broadband Router Software Configuration Guide</i> http://www.cisco.com/en/US/docs/cable/cmts/ubr10012/configuration/guide/scg.html <li data-bbox="493 783 1521 894">• Cisco uBR10012 Router Software Features http://www.cisco.com/en/US/products/hw/cable/ps2217/products_feature_guides_list.html <li data-bbox="493 909 1521 980">• <i>Cisco Cable Modem Termination System Feature Guide</i> http://www.cisco.com/en/US/docs/cable/cmts/feature/guide/cmtsfg.html <li data-bbox="493 995 1521 1106">• <i>Wideband Modem Resiliency Feature Guide</i> http://www.cisco.com/en/US/docs/ios/cable/configuration/guide/ubr_wm_resiliency.html <li data-bbox="493 1121 1521 1232">• <i>Dynamic Bandwidth Sharing on the Cisco CMTS Router Feature Guide</i> http://www.cisco.com/en/US/docs/ios/cable/configuration/guide/cmts_dyn_bw_sharing.html <li data-bbox="493 1247 1521 1358">• <i>DOCSIS WFQ Scheduler on the Cisco CMTS Routers Feature Guide</i> http://www.cisco.com/en/US/docs/ios/cable/configuration/guide/ubr_docsis_wfq_sch.html

Related Topic	Document Title
Cisco IOS command reference and related information	<ul style="list-style-type: none"> For Cisco Wideband SIP and Wideband SPA commands, see Chapter 11, “SIP and SPA Commands” in the <i>Cisco uBR10012 Universal Broadband Router SIP and SPA Software Configuration Guide</i>. <i>Cisco Broadband Cable Command Reference Guide</i> http://www.cisco.com/en/US/docs/ios/cable/command/reference/cbl_book.html <i>Cisco IOS Release 12.3 web page</i> http://www.cisco.com/en/US/products/sw/iosswrel/ps5187/index.html <i>Cisco CMTS Error Messages</i> http://www.cisco.com/en/US/docs/cable/cmts/system/message/uberrchap2.html <i>Cisco CMTS Universal Broadband Router MIB Specifications Guide</i> http://www.cisco.com/en/US/docs/cable/cmts/mib/reference/guide/mibv5ubr.html
Additional cable/broadband information resources	<ul style="list-style-type: none"> Cisco uBR10012 troubleshooting and alerts http://www.cisco.com/en/US/products/hw/cable/ps2209/tsd_products_support_troubleshoot_and_alerts.html Cisco Cable/Broadband Software Center web page http://www.cisco.com/en/US/products/ps6895/serv_group_home.html Cisco Cable/Broadband Technical Support web page http://www.cisco.com/cisco/web/psa/default.html?mode=tech Cisco Multiservice Broadband Cable Guide http://www.cisco.com/en/US/prod/collateral/video/ps8806/ps5684/ps2209/prod_brochure09186a008014eeb0.pdf

Conventions

This guide uses the following conventions for command syntax descriptions and textual emphasis:

Table 2 Command Syntax and Emphasis Conventions

Convention	Description
boldface font	Commands and keywords are in boldface .
<i>italic</i> font	Arguments for which you supply values are in <i>italics</i> .
[]	Elements in square brackets are optional.
{x y z}	Alternative, mutually exclusive, keywords are grouped in braces and separated by vertical bars.
[x y z]	Optional alternative keywords are grouped in brackets and separated by vertical bars.
string	A nonquoted set of characters. Do not use quotation marks around the string or the string will include the quotation marks.
screen font	Terminal sessions and information the system displays are in screen font.
boldface screen font	Information you must enter is in boldface screen font.

Table 2 Command Syntax and Emphasis Conventions (continued)

Convention	Description
<i>italic screen font</i>	Arguments for which you supply values are in <i>italic screen font</i> .
^	The symbol ^ represents the key labeled Control—for example, the key combination ^D in a screen display means hold down the Control key while you press the D key.
< >	Nonprinting characters, such as passwords, are in angle brackets in contexts where italics are not available.
[]	Default responses to system prompts are in square brackets.
!, #	An exclamation point (!) or a pound sign (#) at the beginning of a line of code indicates a comment line.

**Note**

This symbol means *reader take note*. Notes contain helpful suggestions or references to material not This symbol means *reader be careful*. In this situation, you might do something that could result in equipment damage or loss of data.

Obtaining Documentation and Submitting a Service Request

For information on obtaining documentation, using the Cisco Bug Search Tool (BST), submitting a service request, and gathering additional information, see *What's New in Cisco Product Documentation* at: <http://www.cisco.com/c/en/us/td/docs/general/whatsnew/whatsnew.html>.

Subscribe to *What's New in Cisco Product Documentation*, which lists all new and revised Cisco technical documentation, as an RSS feed and deliver content directly to your desktop using a reader application. The RSS feeds are a free service.



Overview for Cisco DOCSIS 3.0 Downstream Solution



Note

The information provided in this document for Cisco DOCSIS 3.0 Downstream Solution is specific to Cisco IOS Releases 12.3(23)BC and 12.2(33)SCB (and later releases). For information that is specific to Cisco IOS Releases 12.3(21)BC and 12.3(21a)BC3, see the *Cisco Cable Wideband Solution Design and Implementation Guide* for these releases at http://www.cisco.com/en/US/docs/cable/cmts/wideband/solution/guide/release_1.0/wb_solu.html

This chapter provides an overview of the Cisco DOCSIS 3.0 Downstream Solution, and contains the following major topics:

- [Overview, page 1-1](#)
- [Cisco DOCSIS 3.0 M-CMTS Solution, page 1-2](#)
- [Cisco DOCSIS 3.0 I-CMTS Solution, page 1-2](#)

Overview

To meet the increasing demand for downstream (DS) and upstream (US) bandwidth, Cisco offers low, mid, and high-range platforms with a rich set of DOCSIS 3.0 compliant line cards. This document describes in detail how multiple RF channels can be aggregated in the downstream direction to achieve significant data rate improvements over single channel modems. For example, in the downstream direction an 8-channel modem can download data at up to 300 Mbps at an Annex B cable plant.

The Cisco CMTS platform supports DOCSIS 3.0 cable interface line cards that can be grouped into the following two main categories:

- Integrated-cable RF-based line cards—This includes the Cisco uBR-MC8X8V and Cisco UBR-MC20X20V cable interface line cards.
- Modular-cable line cards —This includes the SPA-24XDS-SFP Wideband Docsis SPA and the Cisco uBR-MC3GX60V cable interface line card. This line card category requires the use of an EQAM device on the downstream portion of the network.

Depending on the cable plant requirement, choose any of the available Cisco platforms and cable interface line cards:

- Low-range requirement—The Cisco uBR7225 router platform, which can support up to two Cisco uBR-MC8X8V integrated cable interface line cards.

- Mid-range requirement—The Cisco uBR7246 router platform, which can support up to four Cisco uBR-MC8x8V integrated cable interface line cards.
- High-range requirement—The Cisco uBR10012 router platform, which offers maximum flexibility by supporting the Cisco UBR-MC20X20V integrated cable line card, the Modena SIP-based modular cable SPA, and the Cisco uBR-MC3GX60V modular cable line card.

**Note**

Cisco uBR-MC8X8V, Cisco UBR-MC20X20V, and Cisco uBR-MC3GX60V cable interface line cards natively support upstream channel bonding in hardware. The Cisco Wideband SIP/SPA combined with a Cisco uBR-MC5X20H line card can also be used to deploy upstream channel bonding in software.

Cisco DOCSIS 3.0 M-CMTS Solution

The Cisco DOCSIS 3.0 modular cable termination system (M-CMTS) solution aggregates multiple downstreams into a single logical wideband channel to deliver a higher bandwidth to the wideband cable modem, which was not possible with the DOCSIS 2.0 solution.

In the Cisco M-CMTS implementation, the DS channels are encapsulated for the Gigabit Ethernet using the Downstream External PHY Interface (DEPI) protocol as defined by DOCSIS 3.0 M-CMTS. The DS channels can be used either as primary-capable channels (narrowband channels), or as part of bonded channels (wideband channels), or both. For more information about the Cisco DOCSIS 3.0 Downstream Solution for the M-CMTS, see [Cisco DOCSIS 3.0 Downstream Solution Overview for the Cisco M-CMTS, page 2-3](#).

Cisco DOCSIS 3.0 I-CMTS Solution

The Cisco DOCSIS 3.0 integrated cable modem termination system (I-CMTS) solution enables high-bandwidth access networks. In the Cisco I-CMTS implementation, the DS channels are processed and encapsulated by the downstream channels of the line cards, which can be used either as primary-capable channels (narrowband channels), or as part of bonded channels (wideband channels), or both. For more information about the Cisco DOCSIS 3.0 Downstream Solution for I-CMTS, see [Cisco DOCSIS 3.0 Downstream Solution Overview for the I-CMTS, page 3-13](#).



Cisco DOCSIS 3.0 Downstream Solution Overview for the Cisco M-CMTS

This chapter provides an overview of the Cisco DOCSIS 3.0 Downstream (DS) Solution for the Cisco Modular Cable Termination System (M-CMTS), and contains the following major topics:

- [Description and Scope, page 2-3](#)
- [Cisco DOCSIS 3.0 DS Solution Key Features, page 2-7](#)
- [Cisco DOCSIS 3.0 DS Solution Components, page 2-10](#)



Note

In this chapter, the terms wideband channel, bonded channel, and bonding group refer to a logical grouping of one or more physical RF channels where the MPEG-TS packets are carried.



Note

The SPA-24XDS-SFP SPA in this chapter is referred to as the Cisco Wideband SPA, unless specified otherwise.

Description and Scope

The Cisco Wideband SPA and Cisco uBR-MC3GX60V line card support Cisco M-CMTS DS channels. In the Cisco M-CMTS implementation, the DS channels are aggregated and encapsulated for the Gigabit Ethernet using the Downstream External PHY Interface (DEPI) protocol as defined by DOCSIS M-CMTS.

In case of the Cisco Wideband SPA, the DS channels can be referred to as SPA DS channels to differentiate them from the Cisco cable interface line card downstream channels. The Cisco M-CMTS DS channels can be used either as primary-capable channels (narrowband channels), or as part of bonded channels (wideband channels), or both. The Cisco DOCSIS 3.0 Downstream Solution provides narrowband data services to support DOCSIS 1.x and DOCSIS 2.0 modems and wideband data services to support DOCSIS 3.0 modems over existing hybrid fiber-coaxial (HFC) networks, and it also enables the DOCSIS 1.x, DOCSIS 2.0 and DOCSIS 3.0 modems to share the same Cisco M-CMTS DS channel.

With the wideband data services, multiple M-CMTS DS channels are aggregated into a single logical wideband channel (bonding group) that delivers higher bandwidth to the wideband cable modem than was not previously possible with DOCSIS 2.0 Solution. This aggregation of the M-CMTS DS channels is referred to as channel bonding.

The maximum bandwidth supported depends on the number of M-CMTS DS channels that can be aggregated into a wideband channel. The Cisco IOS Release 12.2(33)SCE has been tested with modems with up to eight DS channels. Some examples of modems tested with the solution are:

- The Scientific Atlanta DPC3010 wideband cable modem supports downstream throughput of 300 Mbps (with a wideband channel consisting of eight RF channels at 6 MHz and 256 QAM). In the upstream path, the DPC3010 has four channels all bondable and supporting approximately 100 Mbps of upstream traffic.)
- The Scientific Atlanta DPC2505 wideband cable modem supports downstream throughput of over 100 Mbps (with a wideband channel consisting of 3 RF channels at 6 MHz and 256 QAM on an Annex B cable plant).

Compatibility with Prior Versions of DOCSIS

The Cisco DOCSIS 3.0 Downstream Solution can be deployed in parallel with DOCSIS 1.x and DOCSIS 2.0 modem technology. The Cisco uBR-MC5X20 cable interface line card along with CISco Wideband SPA, supports DOCSIS 1.x, DOCSIS 2.0, and DOCSIS 3.0 cable modems on SPA primary-capable downstream channels and SPA bonded channels. The Cisco uBR-MC3GX60V cable interface line card also supports DOCSIS 1.x/2.0 and DOCSIS 3.0 cable modems on primary-cable downstream channel and bonded channels.

Cisco DOCSIS 3.0 Solution Capabilities

The Cisco DOCSIS 3.0 DS Solution provides the following capabilities:

- Primary-capable DS channels that are provided by Cisco Wideband SPA and Cisco uBR-MC3GX60V cable interface line card. Primary-capable channels carry the proper signalling to register and maintain DOCSIS modems. Non-primary-capable channels are used only to bear data traffic. A modem must be able to tune to at least one frequency that carries a primary-capable channel.

Primary-capable channels on the Wideband SPA DS channels (also known as SPA RF channels) are associated with the upstream channels from the cable interface line cards (for example, Cisco uBR10-MC5X20 line card). To be primary-capable, these downstream channels carry SYNC messages, Upstream Channel Descriptors (UCD), and Mini-slot Allocation Packet (MAP) messages for at least one upstream channel. They may also carry primary MAC Domain Descriptor (MDD) messages for DOCSIS 3.0 modems.

This capability provides following advantages:

- Increases legacy downstream port density.
- Allows legacy and bonded modems to share the same SPA DS channels.
- Supports 3-channel bonding for 3-channel modems and 8-channel bonding for Linksys modems on the SPA DS channels.
- Extensible MAC domain for the Cisco uBR10-MC5X20 and Cisco uBR-MC3GX60V cable interface line cards. This capability has following advantages:
 - Provides support for multiple primary-capable channels per MAC domain.
 - Allows flexible upstream and downstream associations within a MAC domain.
 - Allows association of bonded channel to MAC domains.
- Primary-capable DS channel selection—Provides primary-capable DS channel selection to facilitate channel bonding and reliability of voice-enabled modems.

- High availability—Provides high availability support for modems on SPA DS channels and Cisco uBR-MC3GX60V cable interface line card.
- DOCSIS 1.x, DOCSIS 2.0, and legacy feature support on Cisco Wideband SPA DS channels.
- DOCSIS 3.0 is supported on Cisco Wideband SPA DS channels and Cisco uBR-MC3GX60V cable interface line card.

Architecture and Scope

The Cisco DOCSIS 3.0 DS Solution includes these major components:

- Wideband cable modem termination system (WCMTS)—Cisco uBR10012 router
The WCMTS is the component located at the cable television system headend or distribution hub and exchanges digital signals with cable modems in a cable network to enable data connectivity to a WAN.
- Cisco Wideband SPA and Cisco Wideband SIP
The Cisco Wideband SIP for the 1-Gbps Wideband SPA is a carrier card that is installed in the Cisco uBR10012 router chassis in slots 1/0, slot 3/0, or both. The SIP provides no network connectivity on its own. The Cisco Wideband SPA that inserts into the bay of the SIP provides ports for network connectivity. It enables cable operators to offer high-speed broadband connectivity.
- Cable interface line cards—Cisco uBR-MC5X20S/U/H and Cisco uBR-MC3GX60V
For more information about the Cisco uBR-MC5X20 line card, see *Configuring the Cisco uBR-MC5X20 Cable Interface Line Card* at the following URL:
http://www.cisco.com/en/US/docs/interfaces_modules/cable/broadband_processing_engines/ubr10_mc5x20s_u_h/feature/guide/mc5x20u.html
For more information about the Cisco uBR-MC3GX60V line card, see *Configuring the Cisco uBR-MC3GX60V Cable Interface Line Card* at the following URL:
http://www.cisco.com/en/US/docs/interfaces_modules/cable/broadband_processing_engines/ubr_mc3gx60v/configuration/guide/mc3g60_cfg.html
- DOCSIS Timing and Control Card (DTCC)
The DTCC provides centralized DOCSIS clock and time-stamp distribution to the cable interface line cards within the WCMTS. This card allows synchronization of the DOCSIS clock and time stamp to an external DTI server.
- DOCSIS Timing Interface (DTI) server
The DTI server provides DOCSIS clock generation in an M-CMTS architecture. It ensures that the DOCSIS time stamp and frequency between the M-CMTS core, edge QAM device, and upstream are synchronized to nanosecond levels.
- Edge QAM device
The edge quadrature amplitude modulation (EQAM) device is a network element that is separate from the Cisco CMTS. It allows operators to leverage the same network resources to support multiple types of services, such as data, voice, and video.
- Wideband cable modem (WCM)
WCMS are modems that are DOCSIS 3.0-compliant and support DS channel bonding.
- Narrowband cable modem (NCM)
NCMs are modems that are DOCSIS 1.x/2.0-compliant and support data from a single RF channel.

Figure 2-1 presents a simplified view of the Cisco DOCSIS 3.0 DS Solution. In Figure 2-1, four RF channels are bonded into a wideband channel (bonding group).

Figure 2-1 Cisco DOCSIS 3.0 Downstream Solution

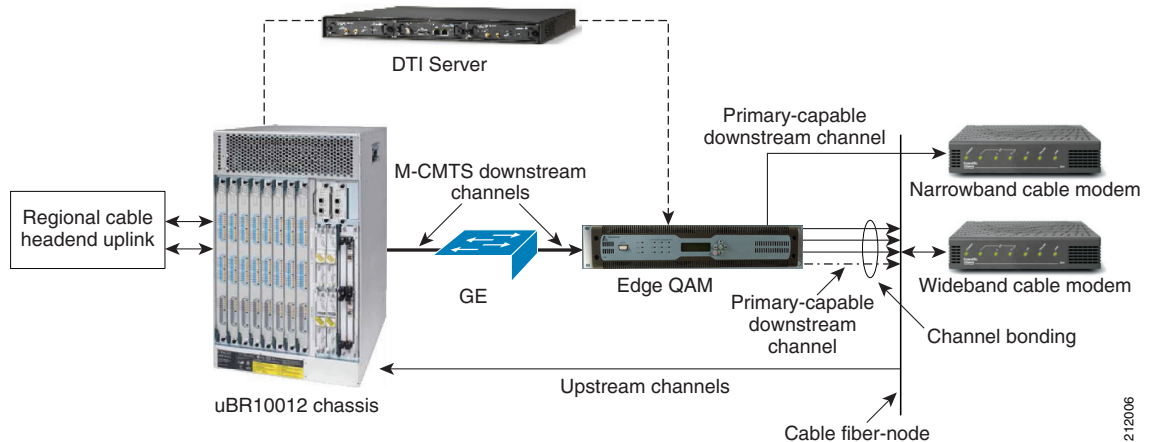

In Cisco IOS Release 12.2(33)SCB, the following components have been added to the scope of the Cisco DOCSIS 3.0 DS Solution:

- Cisco 10000 SIP-600 SPA Interface Processor

The Cisco SIP-600 is a high-performance, feature-rich SIP that functions as a carrier card for Wideband SPAs on the Cisco uBR10012 router. The SIP is compatible with one or more platform-independent SPAs.

- Gigabit Ethernet SPA

In addition to the Cisco Wideband SPA, the Cisco SIP-600 also supports the following Gigabit Ethernet SPAs:

- 5-Port Gigabit Ethernet SPA
- 1-Port 10-Gigabit Ethernet SPA (supported on PRE4 only)

In Cisco IOS Release 12.2(33)SCE, the Cisco uBR-MC3GX60V cable interface line card has been added to the scope of the Cisco DOCSIS 3.0 DS solution.

Starting with Cisco IOS Release 12.2(33)SCG, MAC domains hosted on the Cisco uBR-MC3GX60V cable interface line card can include DS channels from the Cisco Wideband SPAs. The Cisco uBR-MC3GX60V cable interface line cards and the Cisco Wideband SPA can now coexist on a single chassis and share DS channels. For more information on how to configure the Cisco Wideband SPA with the Cisco uBR-MC3GX60V cable interface line card, see *Configuring the Cisco uBR-MC3GX60V Cable Interface Line Card* at the following URL:

http://www.cisco.com/en/US/docs/interfaces_modules/cable/broadband_processing_engines/ubr_mc3gx60v/configuration/guide/mc3g60_cfg.html

Cisco DOCSIS 3.0 DS Solution Scope

The scope of the Cisco DOCSIS 3.0 DS Solution comprises fully tested and supported Cisco and Scientific Atlanta components, as well as selected third-party components that Cisco has tested for interoperability.

The following aspects of the Cisco DOCSIS 3.0 DS Solution are in scope:

- DOCSIS 3.0 DS software
- Wideband CMTS (Cisco uBR10012 router)
- Cable interface and network uplink line cards
- Cisco Wideband SIP and Cisco Wideband SPA
- DTCC
- DTI server
- Edge QAM device
- Narrowband cable modem
- Wideband cable modem
- DOCSIS 1.x, DOCSIS 2.0 and DOCSIS 3.0 cable modem configuration file parameters
- Cisco IOS command set for wideband channel configuration, provisioning, and maintenance
- Cisco IOS command set for wideband hardware monitoring, troubleshooting, and debugging
- MIBs for the wideband CMTS, wideband cable modem, and wideband channel and service statistics

Device configuration that is in scope for this document is limited to the Cisco uBR-MC3GX60V cable interface line card, Cisco Wideband SIP, and Cisco Wideband SPA.

Comprehensive documentation for other Cisco CMTS components is provided in the existing Cisco uBR10012 documentation set, which is accessible at www.cisco.com.

For information on Edge QAM device installation and software configuration, refer to the Edge QAM device documentation provided by the vendor.

Out of Scope

The Cisco DOCSIS 3.0 DS Solution related information in this document pertains to the components listed in the “[Cisco DOCSIS 3.0 DS Solution Scope](#)” section. The hardware and software components that make up the remainder of the cable data network, are not included in the scope of the Cisco DOCSIS 3.0 DS Solution.

For the Cisco DOCSIS 3.0 DS Solution, the cable network management tools and operations support system (OSS) facilities for wideband cable, are outside the scope of the solution.

Cisco DOCSIS 3.0 DS Solution Key Features

For each major release, key features are listed in the following sections.

Starting with Cisco IOS Release 12.3(23)BC, the Cisco DOCSIS 3.0 DS Solution provides the following key features:

- Primary-capable Wideband SPA DS channels
 - Modular-cable interfaces
Represents the narrowband capability of a SPA DS channel.
 - DOCSIS 1.x and DOCSIS 2.0 cable modem support on primary-capable SPA DS channels
Primary-capable channels provide narrowband data services to support DOCSIS 1.x and DOCSIS 2.0 modems.

- Increased port density

Provides up to 48 SPA DS channels plus 40 built-in DS channels in addition to the DS channels on the Cisco uBR10-MC5X20 cable interface line cards for DOCSIS 1.x and DOCSIS 2.0 traffic.
- SPA DS channel sharing

Provides narrowband data services to support DOCSIS 1.x and DOCSIS 2.0 modems and wideband data services to support DOCSIS 3.0 cable modems over HFC networks; it also enables DOCSIS 1.x, DOCSIS 2.0 and DOCSIS 3.0 cable modems to share the same SPA RF channel.
- Enhancements to SPA DS channels
 - Annex and modulation configurable for individual SPA RF channels
 - Layer 2 Transport Protocol (L2TP) encapsulation support on Downstream External PHY Interface (DEPI)
 - Each Cisco Wideband SPA can support up to 24 downstream RF channels and 32 logical wideband channels (bonding groups).
 - Extensible MAC domain construction using Channel Grouping Domain (CGD)
 - Flexible association of primary-capable SPA DS channels with upstream channels within the same MAC domain
- DOCSIS 1.x, DOCSIS 2.0 and legacy feature support on primary-capable SPA DS channels
 - Load balancing
 - Virtual interface bundling
 - Full DOCSIS Quality of Service (QoS)
 - Committed Information Rate (CIR) Admission Control
 - Bonded multicast
 - Non-bonded multicast
 - DOCSIS Set-top Gateway (DSG)
 - Subscriber Accounting and Management Interface Specification (SAMIS)
 - Multiprotocol Label Switching (MPLS) and Virtual Private Network (VPN)
 - Baseline Privacy Interface (BPI) and Baseline Privacy Interface Plus (BPI+)
 - Payload Header Suppression (PHS)
 - Packet Cable and PacketCable™ Multimedia (PCMM)
 - Cable modem flaplist
 - Source verify (with Dynamic Host Configuration Protocol [DHCP] option)
 - Computer Assisted Law Enforcement Act (CALEA), Service Independent Intercept (SII), and Packet Intercept
 - Cable modem remote query
 - DOCSIS packet filters
 - Cable Address Resolution Protocol (ARP)
- Channel bonding of downstream channels from the SPA for DOCSIS 3.0 cable modem support.
- Downstream channel selection

- Provides support for voice-enabled cable modems
- Existing Cisco uBR10012 router can be upgraded to wideband CMTS with add-on components.
- Cisco DOCSIS 3.0 DS Solution supports timing synchronization to the DTI server using DTCC.
- The Cisco Wideband SPA supports external Gigabit Ethernet interface to connect to the EQAM device directly or through the network.
- Cisco uBR10012 router (CMTS) supports up to two Cisco Wideband SPAs in a Wideband SIP.
- Cisco Wideband CMTS and line cards have built-in redundancy and resiliency features.
- Harmonic NSG 9000 edge QAM device is tested for interoperability.
- The Symmetricom TimeCreator 1000 DTI server is tested for interoperability.
- Linksys WCM300-NA, WCM300-EURO (for EuroDOCSIS), and WCM300-JP (for J-DOCSIS) wideband cable modems support the receiving of up to eight RF channels, which can be bonded into wideband channels. One traditional DOCSIS DS channel is used for MAC management and signaling messages.
- Linksys WCM300-NA, WCM300-EURO, and WCM300-J wideband cable modems support one primary bonded (wideband) channel for unicast and multicast traffic and up to two secondary bonded channels for multicast traffic.
- Scientific Atlanta DPC2505 and EPC2505 wideband cable modems support one bonded DS channel consisting of three RF channels, of which one RF channel is a primary DS channel that is used for cable modem registration.

Starting with Cisco IOS Release 12.2(33)SCB, the following additional features are supported on the Cisco DOCSIS 3.0 DS Solution:

- DOCSIS WFQ Scheduler

The DOCSIS WFQ Scheduler is an output packet scheduler that provides output scheduling services on both WAN uplink interfaces and DOCSIS DS interfaces.
- CMTS Dynamic Bandwidth Sharing

This new Cisco CMTS feature enables dynamic bandwidth sharing (DBS) on modular cable and wideband cable interfaces.
- Voice support on wideband modems

CMTS supports voice services on voice-enabled wideband cable modems.
- Wideband Modem Resiliency

The Wideband Modem Resiliency feature provides the best possible service in the event of non-primary RF channel disruptions to ensure that a cable modem remains operational. With the implementation of this feature, the Cisco CMTS does not force a cable modem to perform a MAC reset if the CM loses connectivity to the Cisco CMTS on one or all of its non-primary RF channels.
- DOCSIS 3.0 DS Bonding for Bronze Certification

The DOCSIS 3.0 DS Bonding for Bronze Certification feature helps cable operators offer new, more bandwidth-intensive services by adding one or more additional DS QAM channels to the standard broadband DOCSIS system.

In Cisco IOS Release 12.2(33)SCE, apart from the features supported in Cisco IOS Release 12.2(23)BC and Cisco IOS Release 12.2(33)SCB, the following additional features are supported on the DOCSIS 3.0 DS Solution:

- Cisco uBR-MC3GX60V cable interface line card support
- N+1 Redundancy for the Cisco uBR-MC3GX60V cable interface line card

**Note**

Starting with Cisco IOS Release 12.2(33)SCE1, the N+1 redundancy feature including DEPI redundancy is supported on the Cisco uBR-MC3GX60V cable interface line card.

- M-CMTS simplification statistics
- Automatic DOCSIS Channel ID Assignment

In Cisco IOS Release 12.2(33)SCG, apart from the features supported in the previous Cisco IOS releases, the following additional feature is supported on the Cisco DOCSIS 3.0 DS solution:

- Cisco Wideband SPA and Cisco uBR-MC3GX60V line card can share downstream channels. The MAC domains hosted on the Cisco uBR-MC3GX60V cable line card can include downstream channels from the Cisco Wideband SPAs.

**Note**

Unless otherwise specified, the information given in this document for the Cisco M-CMTS DS solution using the Cisco Wideband SPA with the Cisco uBR10-MC5X20 line card is applicable to the Cisco M-CMTS DS solution using the Cisco Wideband SPA and the Cisco uBR-MC3GX60V line card.

Cisco DOCSIS 3.0 DS Solution Components

Cisco DOCSIS 3.0 Downstream consists of Cisco and Scientific Atlanta components that are tested, documented, and fully supported by Cisco or Scientific Atlanta. Also, third-party equipment, although not fully supported by Cisco, has been selected and tested for interoperability with the solution components.

Cisco and Scientific Atlanta Equipment

For the Cisco DOCSIS 3.0 DS solution, the following Cisco and Scientific Atlanta equipment have been tested in the context of the solution:

- Cisco uBR10012 universal broadband router with route processor (PRE) modules and the following components:
 - Cisco SIP for the 1-Gbps Wideband SPA—Referred to in this document as the Cisco Wideband SIP or Wideband SIP
 - Cisco 1-Gbps Wideband SPA—Referred to in this document as the Cisco Wideband SPA or Wideband SPA
 - Cisco uBR10-MC5X20S/U/H, Cisco uBR10-MC5X20U-D or Cisco uBR-MC3GX60V cable interface line cards.

**Note**

The Cisco uBR-MC3GX60V cable interface line card cannot be used with PRE2.

- Wideband cable modem
 - Linksys WCM300-NA, WCM300-EURO, and WCM300-JP wideband cable modems Scientific Atlanta DPC2505 and EPC2505 wideband cable modems
 - Scientific Atlanta DPC3000 and DPC3010 modems
- Cisco RF Gateway 1 and Cisco RF Gateway 10

Third-Party Equipment

For the Cisco DOCSIS 3.0 DS Solution, [Table 2-1](#) lists the third-party component, vendor, and the basic functionality provided by each component.

Table 2-1 *Component Partners and Basic Functionality*

Component and Vendor	Basic Functionality
Symmetricon TimeCreator 1000 www.symmetricon.com	DTI Server
Harmonic NSG 9000 www.harmonicinc.com	Edge QAM device



Cisco DOCSIS 3.0 Downstream Solution Overview for the I-CMTS

This chapter provides an overview of the Cisco DOCSIS 3.0 Downstream Solution for Integrated Cable Termination System (I-CMTS), and contains the following major topics:

- [Description and Scope, page 3-13](#)
- [Cisco DOCSIS 3.0 Downstream Solution Key Features, page 3-15](#)
- [Cisco DOCSIS 3.0 Downstream Solution Components, page 3-16](#)

Cisco integrated cable modem termination systems (I-CMTS) DOCSIS 3.0 solution enables high-bandwidth access networks. The Cisco family of DOCSIS-compliant I-CMTS routers includes the high-capacity Cisco uBR10012 and the mid-range Cisco uBR7246VXR, and Cisco uBR7225VXR universal broadband routers.

Description and Scope

Cisco IOS Release 12.3(23)SCD introduces the DOCSIS 3.0 Downstream Channel Bonding feature for the Cisco uBR7200 series routers.

In the Cisco I-CMTS implementation, the downstream (DS) channels are processed and encapsulated by the downstream (DS) channels of the line cards, which can be used either as primary-capable channels (narrowband channels), or as part of bonded channels (wideband channels), or both.

Architecture and Scope

The Cisco DOCSIS 3.0 Downstream Channel Bonding includes these major components:

- Integrated cable modem termination system (I-CMTS)—Cisco uBR10012, Cisco uBR7246VXR, and Cisco uBR7225VXR routers

The I-CMTS solution provides the building blocks to enable operators to offer highly competitive, high-bandwidth services at a reduced cost per bit.

- Cable integrated line cards—Cisco UBR-MC20X20V and Cisco uBR-MC8X8V

For more information about the Cisco UBR-MC20X20V line card, see *Configuring the Cisco UBR-MC20X20V Cable Interface Line Card* at the following URL:

http://www.cisco.com/en/US/docs/interfaces_modules/cable/broadband_processing_engines/ubr_mc20x20v/configuration/guide/mc20x20v_cfg.html

For more information about the Cisco uBR-MC8X8V cable interface line card, see the *Configuring the Cisco uBR-MC88V Cable Interface Line Card* at the following URL:

http://www.cisco.com/en/US/docs/interfaces_modules/cable/broadband_processing_engines/ubr_mc88v/configuration/guide/mc8x8v_cfg.html

- Wideband cable modem (WCM)
WCMs are modems that are DOCSIS 3.0-compliant and support downstream channel bonding.
- Narrowband cable modem (NCM)
NCMs are modems that are DOCSIS 1.x and DOCSIS 2.0 compliant and support data from a single RF channel.
- DOCSIS Timing, Communication and Control (DTCC)

**Note**

If you are using the Cisco UBR-MC20X20V linecards, dual DTCC are required.

**Note**

The Cisco uBR7200 series routers do not support any external Timing and Control Cards.

Figure 3-1 presents a simplified view of the Cisco DOCSIS 3.0 Downstream Solution.

Figure 3-1 Cisco DOCSIS 3.0 Downstream Solution

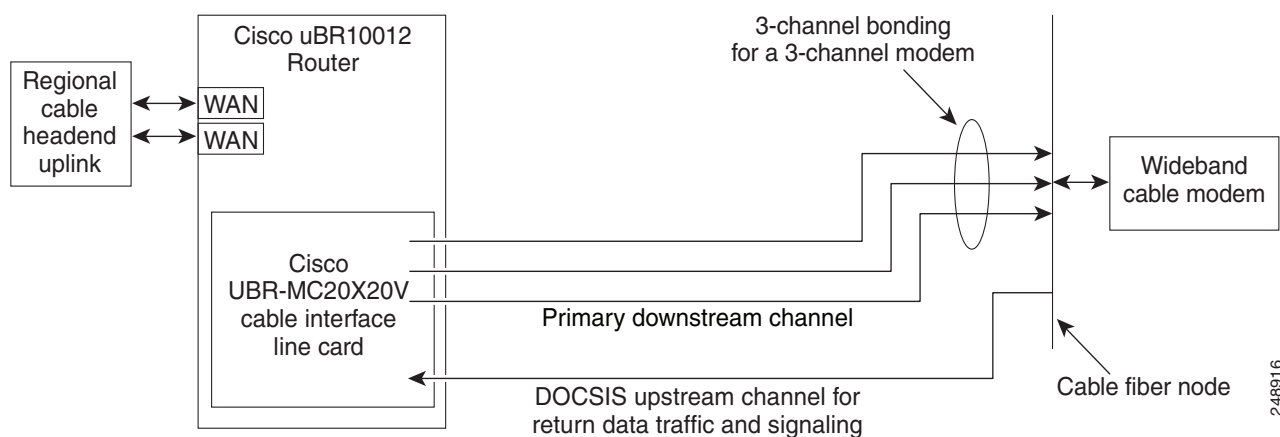

In Scope

The scope of the Cisco DOCSIS 3.0 Downstream Channel Bonding comprises fully tested and supported Cisco and Scientific Atlanta components, as well as selected third-party components that Cisco has tested for interoperability.

The following aspects of the solution are in scope:

- DOCSIS 3.0 Downstream software
- I-CMTS routers (Cisco uBR10012, Cisco uBR7246VXR, and Cisco uBR7225VXR routers)
- Timing and Control Card
- TCC+ server



Note The Cisco uBR7200 series routers do not support any external Timing and Control Cards.

- Cable interface line cards, such as Cisco UBR-MC20X20V and Cisco uBR-MC8X8V cable interface line cards
- Wideband cable modem
- DOCSIS 1.x and DOCSIS 2.0 cable modem configuration file parameters
- DOCSIS 3.0 cable modem configuration file parameters
- Cisco IOS command set for wideband-channel configuration, provisioning, and maintenance
- Cisco IOS command set for wideband hardware monitoring, troubleshooting, and debugging
- MIBs for the wideband CMTS, wideband cable modem, and wideband channel and service statistics

Out of Scope

The hardware and software components that make up the remainder of the cable data network are out of scope of the DOCSIS 3.0 Downstream Channel Bonding solution.

Cable network management tools and operations support system (OSS) facilities for wideband cable are also outside the scope of the solution.

Cisco DOCSIS 3.0 Downstream Solution Key Features

Cisco DOCSIS 3.0 Downstream Solution that includes support for the following functionality:

- Extensible MAC domain construction using Channel Grouping Domain (CGD)
 - Load balancing
 - Virtual interface bundling
 - Full DOCSIS Quality of Service (QoS)
 - Committed Information Rate (CIR) Admission Control
 - Bonded multicast
 - Non-bonded multicast
 - DOCSIS Set-top Gateway (DSG)
 - Subscriber Accounting and Management Interface Specification (SAMIS)
 - Multiprotocol Label Switching (MPLS) and Virtual Private Network (VPN)
 - Baseline Privacy Interface (BPI) and Baseline Privacy Interface Plus (BPI+)
 - Payload Header Suppression (PHS)
 - Packet Cable and PacketCable™ Multimedia (PCMM)
 - Cable modem flaplist
 - Source verify (with Dynamic Host Configuration Protocol (DHCP) option)
 - Computer Assisted Law Enforcement Act (CALEA), Service Independent Intercept (SII), and Packet Intercept
 - Cable modem remote query

- DOCSIS packet filters
- Cable Address Resolution Protocol (ARP)
- Downstream channel selection
- Provides support for voice-enabled cable modems
- Existing Cisco uBR10012 router (CMTS) can be upgraded to wideband CMTS with add-on components.
- Cisco Wideband CMTS and line cards have resiliency features and N+1 line card high-availability (LCHA).
- DOCSIS 3.0-compliant wideband cable modems
- DOCSIS WFQ Scheduler

The DOCSIS WFQ Scheduler is an output packet scheduler that provides output scheduling services on both WAN uplink interfaces and DOCSIS downstream interfaces.
- CMTS Dynamic Bandwidth Sharing

The new CMTS feature enables dynamic bandwidth sharing (DBS) on modular cable and wideband cable interfaces.
- Voice support on wideband modems

CMTS supports voice services on voice-enabled wideband (WB) cable modems.
- Wideband Modem Resiliency

The Wideband Modem Resiliency feature provides the best possible service in the event of non-primary RF channel disruptions to ensure that a cable modem remains operational. With the implementation of this feature, the CMTS does not force a cable modem to perform a MAC reset if the CM loses connectivity to the CMTS on one or all of its non-primary RF channels.
- DOCSIS 3.0 Downstream Bonding for Bronze Certification

The DOCSIS 3.0 Downstream Bonding for Bronze Certification feature provides new, more bandwidth-intensive services by adding one or more additional downstream quadrature amplitude modulation (QAM) channels to the standard broadband DOCSIS system.

Cisco DOCSIS 3.0 Downstream Solution Components

For the Cisco DOCSIS 3.0 Downstream Solution, the following equipment have been tested in the context of the solution:

- Cisco uBR10012 universal broadband router with route processor (PRE) modules and these components:
 - Cisco UBR-MC20X20V cable interface line cards
- Cisco uBR7225VXR and Cisco uBR7246VXR routers with NPE-G2 processor and Cisco uBR-MC8X8V line card
- Wideband cable modem
 - DOCSIS 3.0-compliant wideband cable modems



Cisco DOCSIS 3.0 Downstream Solution Components

This chapter describes the components of the Cisco DOCSIS 3.0 Downstream Solution and contains the following topics:

- [Base CMTS Components, page 4-1](#)
- [Wideband CMTS Components, page 4-9](#)
- [Wideband Cable Modems, page 4-15](#)
- [Wideband CMTS Redundancy and Resiliency, page 4-17](#)
- [Where to Find Information on Solution Hardware Components, page 4-22](#)



Note

The Cisco uBR10012 router can be used as a DOCSIS 1.X or DOCSIS 2.0 CMTS. In this mode the Cisco uBR10012 router does not need any wideband components. Wideband cable components can be added to the Cisco uBR10012 base system so that it can be used as a wideband CMTS. As demand for wideband cable grows, this ability to increase capacity by adding wideband components to an existing Cisco uBR10012 base system is less expensive than adding an additional chassis. This add-on strategy of the Cisco DOCSIS 3.0 Downstream Solution reduces both capital expenditure and operational expenses.

Base CMTS Components

For the Cisco DOCSIS 3.0 Downstream Solution, the Cisco uBR10012 router ([Figure 4-1](#), [Figure 4-2](#) and [Figure 4-3](#)) is the wideband cable modem termination system (WCMTS). The CMTS may be located at the cable headend or at a distribution hub. The Cisco DOCSIS 3.0 Downstream Solution uses the modular CMTS (M-CMTS) architecture or integrated CMTS (I-CMTS), with an external DTI server and one or more external EQAM devices.

Figure 4-1 Wideband CMTS: Cisco uBR10012 Router—Front View without Front Cover

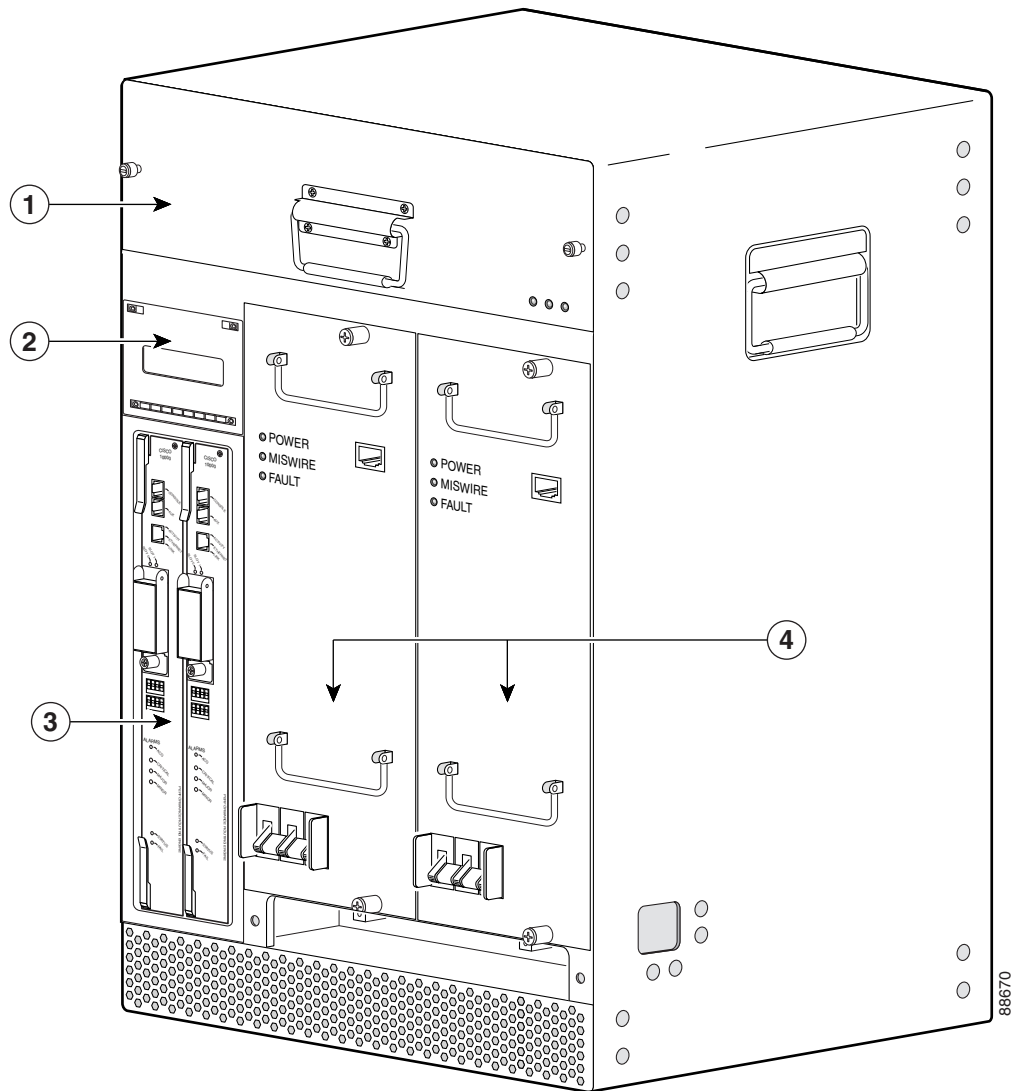

1	Fan assembly module	3	Two route processor (PRE) modules
2	LCD module	4	Two DC Power entry modules (DC PEMs)

Figure 4-2 Wideband CMTS: Cisco uBR10012 Router With Cisco uBR-MC5X20 card—Rear View

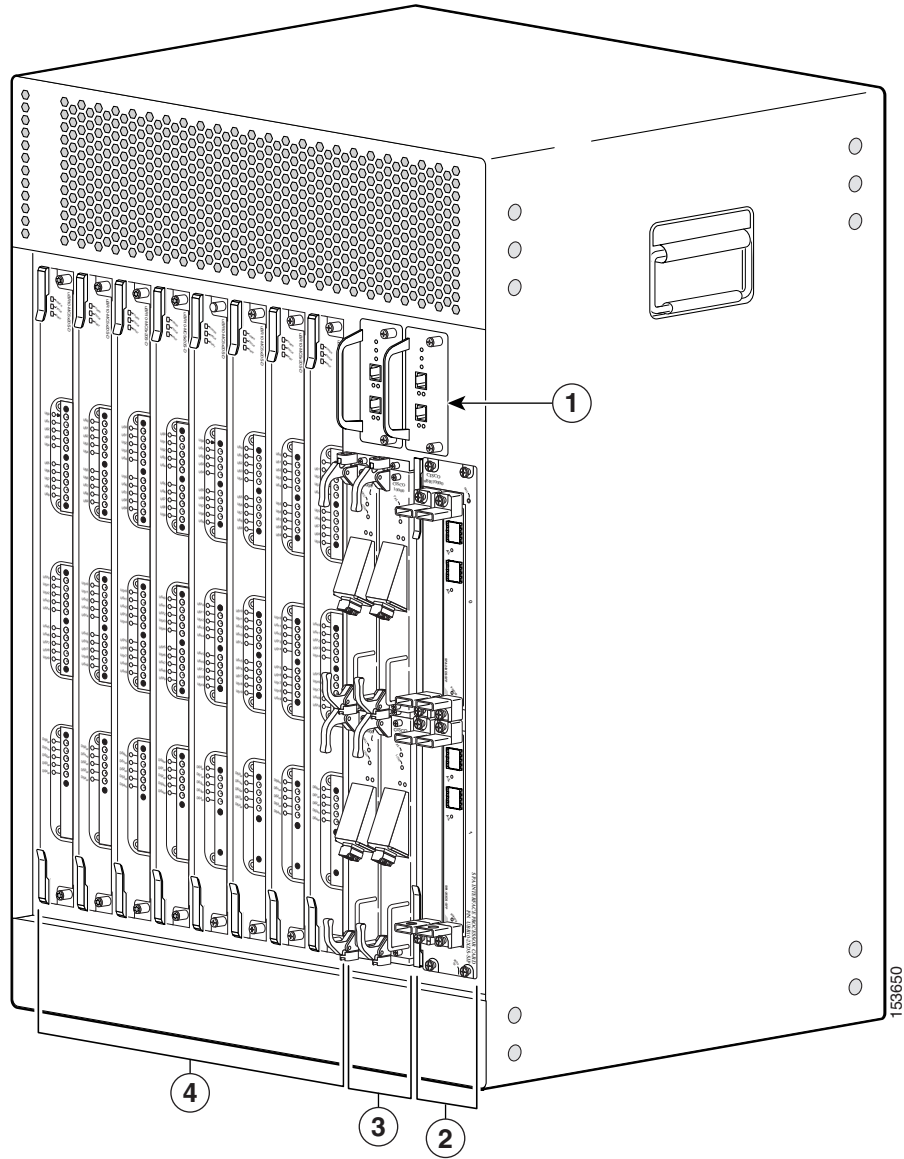

1	Two DOCSIS Timing and Control Cards (DTCC)	3	Four Half-Height Gigabit Ethernet line cards
2	One Wideband SIP with two Wideband SPAs	4	Eight Cisco uBR10-MC5X20S/U/H or Cisco uBR10-MC5X20U-D cable interface line cards

Figure 4-3 Wideband CMTS: Cisco uBR10012 Router with Cisco uBR-MC3GX60V card—Rear View

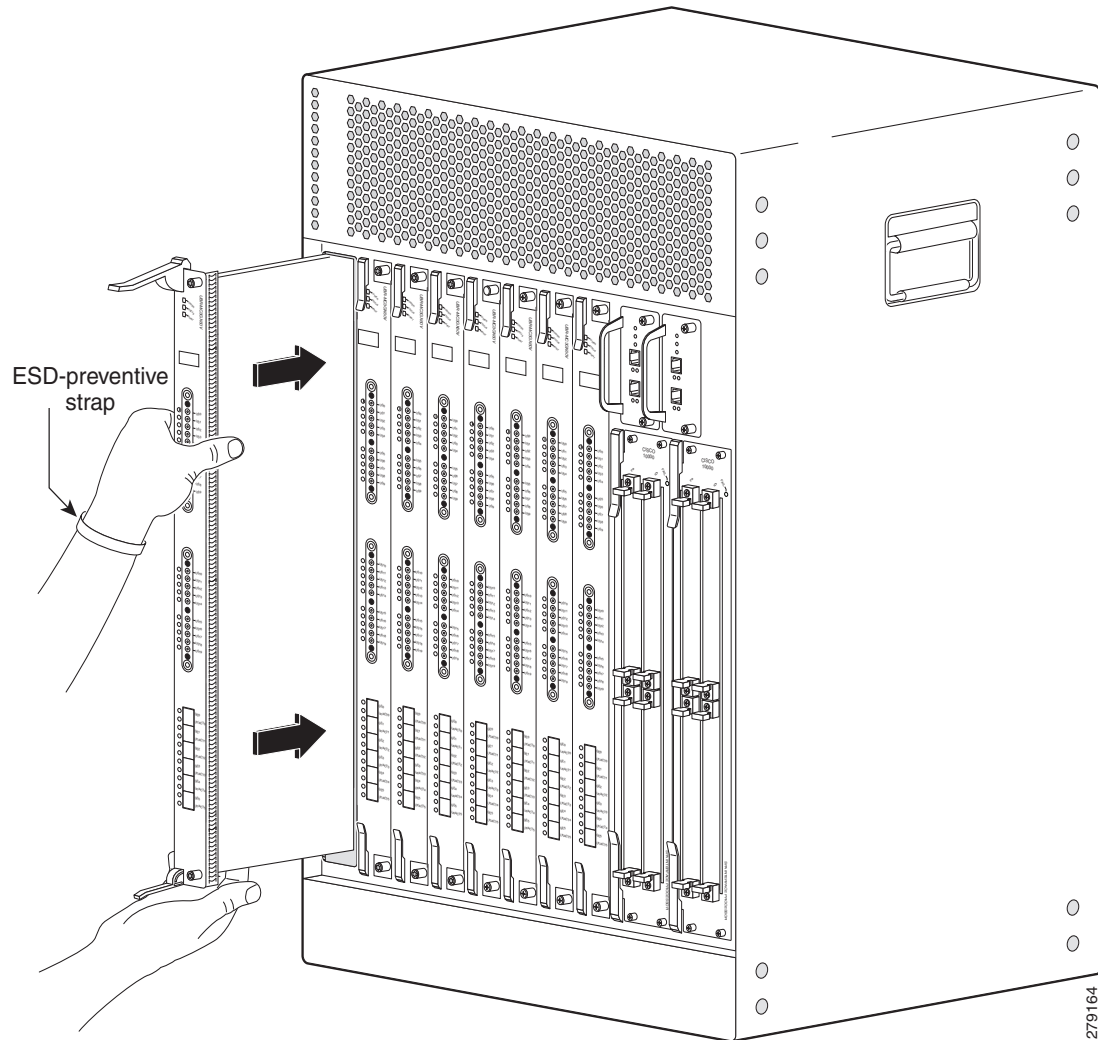

Figure 4-2 and Figure 4-3 shows a fully loaded Cisco uBR10012 chassis. The minimum number of components needed for base CMTS or wideband CMTS operation requires fewer cards than shown in Figure 4-2 and Figure 4-3. For information on minimum and recommended hardware requirements, see the “Base CMTS Component Requirements” section on page 4-4 and the “Wideband CMTS Components” section on page 4-9.

Base CMTS Component Requirements

For the Cisco uBR10012 base system, Table 4-1 lists the minimum and recommended hardware configurations for major components using Cisco uBR-MC3GX60V cable interface line card. The base system can be used as a DOCSIS 1.x or DOCSIS 2.0 CMTS and can be upgraded to a wideband CMTS. In the Recommended column, the number of components ensures that the Cisco uBR10012 router has component redundancy where it is available.

Cisco IOS Release 12.3(21)BC or a later release is required for supporting wideband cable functionality.

Table 4-1 Cisco uBR10012 Base System: Minimum and Recommended Hardware using uBR-MC3GX60V Cable Interface Line Card

Component	Minimum	Recommended
Performance Routing Engine 4 (PRE4) or PRE5	1	2
DOCSIS Timing and Control Card (DTCC)	1	2
DC power entry modules (DC PEMs)	1	2
or		
AC power entry modules (AC PEMs)		
Fan assembly module	1	1
LCD module	1	1
Cable Interface Line Cards and Network Uplink Line Cards		
Cisco uBR-MC3Gx60V cable interface line card	1	At least 2 ¹
Cisco SIP-600	1	2
Redundant SIPs can be used to provide WAN redundancy with 2 Gigabit SPAs with proper routing protocol configuration.		
Cisco 1X10 Gigabit SPA or 5x1 Gigabit SPA	1	2

1. The number of line cards and slot splitter cards required will vary depending on the set of services and number of subscribers being supported.

For the Cisco uBR10012 base system, [Table 4-2](#) lists the minimum and recommended hardware configurations for major components using Cisco UBR-MC20X20V cable interface line card for I-CMTS.

Table 4-2 Cisco uBR10012 Base System: Minimum and Recommended Hardware Using Cisco UBR-MC20X20V Cable Interface Line Card

Component	Minimum	Recommended
Performance Routing Engine 2 (PRE2), PRE4, or PRE5	1	2
DOCSIS Timing and Control Card (DTCC)	1	2
DC power entry modules (DC PEMs)	1	2
or		
AC power entry modules (AC PEMs)		
Fan assembly module	1	1
LCD module	1	1
Cable Interface Line Cards and Network Uplink Line Cards		
Cisco UBR10-MC20X20V cable interface line card	1	At least 2 ¹

Table 4-2 Cisco uBR10012 Base System: Minimum and Recommended Hardware Using Cisco UBR-MC20X20V Cable Interface Line Card (continued)

Component	Minimum	Recommended
Cisco SIP-600 and Cisco 5x1 Gigabit SPA or 10 Gigabit SPA or Half-Height Gigabit Ethernet (HHGE) network uplink line card.	1	At least 2 ¹
Slot splitter card (One is required for each two HHGE line cards.)	1	Varies ¹

1. The number of line cards and slot splitter cards required will vary depending on the set of services and number of subscribers being supported.

For the Cisco uBR10012 base system, [Table 4-3](#) lists the minimum and recommended hardware configurations for major components using the combination of a Cisco uBR-MC5X20 line card and M-CMTS SPAs.

Table 4-3 Cisco uBR10012 Base System: Minimum and Recommended Hardware Using Cisco uBR-MC5X20 Cable Interface Line Card

Component	Minimum	Recommended
Performance Routing Engine 2 (PRE2) or PRE4	1	2
DOCSIS Timing and Control Card (DTCC)	1	2
DC power entry modules (DC PEMs) or AC power entry modules (AC PEMs)	1	2
Fan assembly module	1	1
LCD module	1	1

Cable Interface Line Cards and Network Uplink Line Cards

Cisco uBR10-MC5X20 cable interface line card	1	At least 2 ¹
Cisco SIP-600 and Cisco 5x1 Gigabit SPA or 10 Gigabit SPA or Half-Height Gigabit Ethernet (HHGE) network uplink line card.	1	At least 2 ¹
Slot splitter card (One is required for each two HHGE line cards.)	1	Varies ¹

1. The number of line cards and slot splitter cards required will vary depending on the set of services and number of subscribers being supported.

The Cisco uBR10012 chassis supports four Half-Height Gigabit Ethernet (HHGE) line cards in slots 3/0 and slot 4/0.

Cable Interface Line Cards and Network Uplink Line Cards

The cable interface line cards and network uplink line cards used on the Cisco uBR10012 base system are described in the following sections:

- [Cisco uBR-MC3GX60V Cable Interface Line Card, page 4-7](#)
- [Cisco uBR-MC5X20S/U/H and Cisco uBR10-MC5X20U-D Cable Interface Line Cards, page 4-7](#)
- [Cisco Half-Height Gigabit Ethernet Line Card, page 4-8](#)
- [Cisco Half-Height Gigabit Ethernet Line Card, page 4-8](#)
- [Cisco Gigabit Ethernet SPAs, page 4-9](#)

Cisco uBR-MC3GX60V Cable Interface Line Card

The Cisco uBR-MC3GX60V cable interface line card is an M-CMTS DOCSIS 3.0-compliant cable line card designed for the Cisco uBR10012 universal broadband chassis. It incorporates 60 upstream channels and 72 downstream channels over 3 separate Gigabit Ethernet ports. This cable line card offers significant cost-per-port reduction while providing lower operating expenditure and easier network operations and maintenance.

For more information on how to configure and implement the M-CMTS solution using Cisco uBR-MC3GX60V line card, see *Configuring the Cisco uBR-MC3GX60V Cable Interface Line Card* at the following URL:

http://www.cisco.com/en/US/docs/interfaces_modules/cable/broadband_processing_engines/ubr_mc3gx60v/configuration/guide/mc3g60_cfg.html

Cisco uBR-MC5X20S/U/H and Cisco uBR10-MC5X20U-D Cable Interface Line Cards

The Cisco uBR10-MC5X20S/U/H and Cisco uBR10-MC5X20U-D cable interface line cards transmit and receive RF signals between the subscriber and the headend over a hybrid fiber-coaxial (HFC) network.

The Cisco uBR-MC5X20S/U/H and Cisco uBR10-MC5X20U-D cable interface line cards can be used for a standard DOCSIS 1.x and DOCSIS 2.0, or for a Cisco DOCSIS 3.0 Downstream Solution or for a combination of the two. These cable interface line cards support upstream and downstream traffic over DOCSIS-based cable modem networks.

For a DOCSIS 1.x, DOCSIS 2.0 or for the Cisco DOCSIS 3.0 Downstream Solution, upstream data from the subscriber comes through the upstream ports (US0/US19) on the line cards. The line card processes and configures the data and sends it across the backplane to the WAN or backhaul card and out to the Internet.

For a DOCSIS 1.x, DOCSIS 2.0 or DOCSIS 3.0 Downstream Solution, downstream data to the subscriber comes from the Internet through the WAN or backhaul card, and across the backplane to the cable interface line card. The cable interface line card processes and configures the data and sends it out through the appropriate downstream port (DS0/DS4) to be combined with the rest of the downstream signals in the headend.

The downstream data traffic of the wideband channel uses the Cisco Wideband SPA and an external edge QAM device. For more information on the Cisco Cable Wideband systems, see [Chapter 5, “Cisco DOCSIS 3.0 Downstream Solution Architecture”](#).

For more information about the Cisco uBR10-MC5X20 cable interface line card, see the *Cisco uBR10-MC5X20S/U/H Cable Interface Line Card Hardware Installation Guide* at the following URL:

http://www.cisco.com/en/US/docs/interfaces_modules/cable/broadband_processing_engines/ubr10_mc5x20s_u_h/installation/guide/ubrmmc520.html

Cisco uBR10-MC5X20S

The Cisco uBR10-MC5X20S cable interface line card supports downstream and upstream traffic over DOCSIS-based cable modem networks. The line card supports downstream channels in the 70 MHz to 860 MHz range, and upstream channels in the 5 MHz to 42 MHz range. Each downstream port includes an onboard integrated upconverter. The Cisco uBR10-MC5X20S cable interface line card supports Annex B RF data rates, channel widths, and modulation schemes and has DOCSIS MAC management and spectrum management capabilities. DOCSIS 2.0 and Asynchronous Time Division Multiple Access (A-TDMA) rates are also supported.

Cisco uBR10-MC5X20U and H

The Cisco uBR10-MC5X20U/H cable interface line card supports both DOCSIS and EuroDOCSIS cable modem networks. The line card supports downstream channels in the 70 MHz to 860 MHz range, and upstream channels in the 5 MHz to 65 MHz range. Each downstream port includes an onboard integrated upconverter. The Cisco uBR10-MC5X20U/H cable interface line card supports Annex B and Annex A RF data rates, channel widths, and modulation schemes and has DOCSIS MAC management and spectrum management capabilities. DOCSIS 2.0 and A-TDMA rates are also supported.

Compared to the Cisco uBR10-MC5X20U, the Cisco uBR10-MC5X20H increases the line card CPU speed, memory, and flash, allowing support of VoIP at much higher call loads and a higher percentage of modems running advanced DOCSIS features that typically consume line card CPU resources.

Cisco uBR10-MC5X20U-D

The Cisco uBR10-MC5X20U-D cable interface line card supports both DOCSIS and EuroDOCSIS cable modem networks. The Cisco uBR10-MC5X20U-D cable interface line card supports Annex A and Annex B RF data rates, channel widths, and modulation schemes, and has DOCSIS MAC management and spectrum management capabilities.

Cisco Half-Height Gigabit Ethernet Line Card

The Cisco Half-Height Gigabit Ethernet (HHGE) line card is a single-port Gigabit Ethernet (GE) line card that provides a trunk uplink to devices, such as backbone routers, connections to content servers and IP telephony gateways. The HHGE line card provides the Cisco uBR10012 router with an IEEE 802.3z-compliant Ethernet interface that can run up to 1 Gbps in full duplex mode.

The Cisco uBR10012 router supports up to four HHGE line cards to allow connectivity to multiple destinations, and to provide network layer redundancy. The HHGE line card requires a slot splitter card that should be installed in either Slot 3/0 or Slot 4/0 on the Cisco uBR10012 router. Each slot splitter can hold two HHGE line cards. Therefore, the Cisco uBR10012 base system with two slot splitters supports up to four HHGE line cards.

The HHGE line card uses a small form-factor pluggable (SFP) Gigabit Interface Converter (GBIC) module that supports a variety of Gigabit Ethernet interface types (SX, LX, LH, and ZX), which you can change or upgrade at any time.

The following SFP modules are supported by the HHGE line card:

- 1000BASE-SX SFP—The SFP-GE-S operates on ordinary multimode fiber optic link spans of up to 1,805 feet (550 m) in length.
- 1000BASE-LX/LH SFP—The SFP-GE-L operates on ordinary single-mode fiber optic link spans of up to 32,808 feet (10,000 m) in length.

- 1000BASE-ZX SFP—The GLC-ZX-SM operates on ordinary single-mode fiber optic link spans of up to 70 kilometers (km) in length. Link spans of up to 100 km are possible using premium single-mode fiber or dispersion-shifted single-mode fiber. The precise link span length depends on multiple factors, such as fiber quality, number of splices, and connectors.
- 1000BASE-T SFP—The SFP-GE-T provides full-duplex Gigabit Ethernet connectivity to high-end workstations and between wiring closets over an existing copper network infrastructure. The SFP-GE-T maximum cabling distance is 328 feet (100 m).

The HHGE line card supports online insertion and removal (OIR) and can be added or removed without powering off the chassis. For more information on the HHGE line card, see the *Cisco uBR10012 Universal Broadband Router Hardware Installation Guide* at the following URL:

http://www.cisco.com/en/US/docs/interfaces_modules/cable/line_cards/ubr_hh_ge/quick/start/ubr_hhge.html

Cisco Gigabit Ethernet SPAs

Cisco offers two Gigabit Ethernet SPA choices for establishing the backhaul uplink that is, the SPA-1X10GE-L-V2 single port SPA and the SPA-5X1GE-V2 5-port SPA. Use of either one of these SPAs requires a SIP-600 card. Due to the increased downstream capacity of the Cisco uBR-MC3GX60V line card, a SPA-1X10GE-L-V2 is often required to be deployed with the Cisco uBR-MC3GX60V.

Cisco Half-Height Gigabit Ethernet (HHGE) line card is a single-port Gigabit Ethernet (GE) line card that provides a trunk uplink to devices, such as backbone routers, connections to content servers and IP telephony gateways. The HHGE line card provides the Cisco uBR10012 router with an IEEE 802.3z-compliant Ethernet interface that can run up to 1 Gbps in full duplex mode.

Wideband CMTS Components

A Cisco uBR10012 base system can be upgraded to a wideband CMTS by adding these components:

- [Wideband SIP and Wideband SPA, page 4-9](#)
- [External Edge QAM Device, page 4-12](#)
- [DOCSIS Timing Interface Server, page 4-14](#)

For information about the wideband CMTS functionality, see the “[Modular CMTS](#)” section on [page 5-41](#).

Wideband SIP and Wideband SPA

The Wideband SIP and Wideband SPA needed for wideband cable can be added to the base Cisco uBR10012 system when they are required. For the Wideband SIP and Wideband SPA, [Table 4-4](#) lists the minimum and recommended hardware configurations.

Table 4-4 Cisco uBR10012 Wideband Components: Minimum and Recommended Hardware

Component	Minimum	Recommended
Wideband SIP (SPA interface processor)	1	1
Wideband SPA (shared port adapter)	1	Varies ¹

1. The number of Wideband SPAs required will vary depending on the set of services and number of subscribers being supported.

Cisco Wideband SIP

A SPA interface processor (SIP) is a carrier card that inserts into a router slot like a line card. The Wideband SIP provides no network connectivity on its own. The Wideband SIP occupies two full-height slots on the Cisco uBR10012 router. Each Wideband SIP supports two Wideband SPAs.

When the Cisco uBR10012 router is used as a wideband CMTS, Slot 1/0 and Slot 2/0 are used for the Wideband SIPs. Slot 3/0 and Slot 4/0 are reserved for HHGE line cards. Online insertion and removal (OIR) is supported for both the Wideband SIP and the individual Wideband SPAs.

For more information on the Wideband SIP, see the *Cisco uBR10012 Universal Broadband Router SIP and SPA Hardware Installation Guide* and the *Cisco uBR10012 Universal Broadband Router SIP and SPA Software Configuration Guide*.

Cisco Wideband SPA

The Wideband SPA is a single-wide, half-height SPA that provides DOCSIS 3.0 downstream support for a DOCSIS network formatting to the downstream data packets. The Wideband SPA is used for downstream data traffic only. It has one active and one redundant Gigabit Ethernet port that are used to send traffic to the external edge QAM device.

The Cisco uBR10012 router can support up to two Wideband SPAs. Each Wideband SPA can support up to 32 logical wideband channels (bonding groups). Depending on how it is configured, each Wideband SPA supports up to 24 RF channels. Each logical wideband channel consists of multiple RF channels. The Cisco IOS CLI includes a set of commands to configure the Wideband SPA on the Cisco uBR10012 router.



Note

All the configurations supported on Cisco Wideband SPA are also supported on the Cisco 3 Gbps Wideband Shared Port Adapter and Cisco 6 Gbps Wideband Shared Port Adapter.

Cisco 6 Gbps Wideband Shared Port Adapter

The Cisco 6 Gbps Wideband Shared Port Adapter is a single-wide, half-height SPA that provides DOCSIS network formatting to downstream data packets. It is used for only downstream data traffic. It is a key component for the Cisco IOS features, DOCSIS 3.0 Downstream Channel Bonding and DOCSIS M-CMTS network architecture.



Note

In the Cisco IOS Release 12.2(33)SCI, the Cisco 6 Gbps Wideband Shared Port Adapter uses the same hardware as the Cisco 3 Gbps Wideband Shared Port Adapter with an upgraded field-programmable device (FPD) image.

The base hostboard is the Cisco 10000 Series SPA Interface Processor-600. Each Cisco 10000 Series SPA Interface Processor-600 jacket can host four Cisco 6 Gbps Wideband Shared Port Adapter cards.

Each Cisco 6 Gbps Wideband Shared Port Adapter has three 1 Gigabit Ethernet ports (no redundant port). The first two Gigabit Ethernet ports on the SPA can be used as a 10 Gigabit Ethernet port (one active and one redundant). The Gigabit Ethernet ports are used to send traffic to one or more external edge QAM devices.

The Cisco uBR10012 router can support up to two Cisco 10000 Series SPA Interface Processor-600 jackets and eight Cisco 6 Gbps Wideband Shared Port Adapters. In the one 10G mode, each Cisco 6 Gbps Wideband Shared Port Adapter card supports up to 144 RF channels and hence a total of 1152 RF channels are supported with eight Cisco 6 Gbps Wideband Shared Port Adapters.

Cisco 3 Gbps Wideband Shared Port Adapter

The Cisco 3 Gbps Wideband Shared Port Adapter is a single-wide, half-height SPA that provides DOCSIS network formatting to downstream data packets. It is used for only downstream data traffic. The Cisco 3 Gbps Wideband Shared Port Adapter is a key component for the Cisco IOS features, DOCSIS 3.0 Downstream Channel Bonding and DOCSIS M-CMTS network architecture. The base hostboard is the Cisco 10000 Series SPA Interface Processor-600. Each Cisco 10000 Series SPA Interface Processor-600 jacket can host four Cisco 3 Gbps Wideband Shared Port Adapter cards.

Each Cisco 3 Gbps Wideband Shared Port Adapter has three 1 Gigabit Ethernet ports (no redundant port). The first two Gigabit Ethernet ports on the SPA can be used as a 10 Gigabit Ethernet port (one active and one redundant). The Gigabit Ethernet ports are used to send traffic to one or more external edge QAM devices.

The Cisco uBR10012 router can support up to two Cisco 10000 Series SPA Interface Processor-600 jackets and eight Cisco 3 Gbps Wideband Shared Port Adapters. In both the three 1G mode and one 10G mode, each Cisco 3 Gbps Wideband Shared Port Adapter card supports up to 72 RF channels and hence a total of 576 RF channels are supported with eight Cisco 3 Gbps Wideband Shared Port Adapters.

Wideband SPA Redundant Gigabit Ethernet Ports

The Wideband SPA has one active and one redundant Gigabit Ethernet port that is used to send traffic to the external edge QAM device. If the link state of both Gigabit Ethernet ports (Port 0 and Port 1) is up, the port that is discovered first as up becomes the active port (forwarding traffic), and the other port becomes the redundant port. The port status LEDs for Port 0 and Port 1 on the Wideband SPA will be green.

Each Gigabit Ethernet port can discover a link failure between itself and the device to which it is directly connected. If both Gigabit Ethernet links from the Wideband SPA to the edge QAM device are up, automatic failover to a redundant link behaves as follows:

- If both Gigabit Ethernet ports are directly connected to the edge QAM device, automatic failover to the redundant link occurs.
- If both Gigabit Ethernet ports are connected to, for example, a switch between the Wideband SPA and the edge QAM device, automatic failover to the redundant link to the switch occurs.
- In the case where there is a switch between the Wideband SPA and the edge QAM device, the SPA cannot detect a link failure between the switch and the edge QAM device. No automatic failover to a redundant Gigabit Ethernet port and link occurs.

The **show controllers modular-cable** command shows the current state of the Wideband SPA Gigabit Ethernet ports. With the Cisco IOS CLI, the Wideband SPA Gigabit Ethernet ports are not specified on the command line as individual Gigabit Ethernet interfaces because the ports work in tandem as a redundant pair.

The two Gigabit Ethernet ports on the Wideband SPA use SFP modules. An SFP module is an I/O device that plugs into the Gigabit Ethernet SFP ports on the Wideband SPA, linking the port with an edge QAM device through a fiber-optic network.

[Table 4-5](#) lists the SFP modules that the Wideband SPA supports.

Table 4-5 SFP Modules for the Cisco Wideband SPA

SFP Module Product Number	SFP Module	Description
SFP-GE-T ¹	1000BASE-T-SFP pluggable transceiver	Cisco 1000BASE-T SFP, pluggable transceiver module, 100-m on Category 5 (Cat5), Category 5e (Cat 5e), and Category 6 (Cat 6) cable.
GLC-SX-MM	Short wavelength (1000BASE-SX)	Cisco 1000BASE-SX SFP transceiver module for multimode fiber (MMF), 850-nm wavelength
GLC-LH-SM	Long wavelength/long haul (1000BASE-LX/LH)	Cisco 1000BASE-LX/LH SFP transceiver module for single-mode fiber (SMF), 1300-nm wavelength
GLC-ZX-SM	Extended distance (1000BASE-ZX)	Cisco 1000BASE-ZX SFP transceiver module for SMF, 1550-nm wavelength

1. Due to slow link loss detection, it is not recommended to use the SFP-GE-T transceivers for primary interfaces.

For more information on the Wideband SPA, see the *Cisco uBR10012 Universal Broadband Router SIP and SPA Hardware Installation Guide* and the *Cisco uBR10012 Universal Broadband Router SIP and SPA Software Configuration Guide*.

External Edge QAM Device

The Cisco wideband CMTS uses one or more external EQAM devices. The EQAM device is a network element in a separate chassis from the CMTS. The EQAM device has two or more Gigabit Ethernet input interfaces that connect to a Wideband SPA. For output, the EQAM device has multiple QAM modulators and RF upconverters that connect to a HFC network. The EQAM device accepts MPEG over IP on its Gigabit Ethernet interfaces and routes the services to its QAM RF outputs.

The Harmonic NSG 9000 edge QAM device, which has up to 72 QAM channels, has been tested for interoperability with other Cisco DOCSIS 3.0 Downstream Solution components.

Cisco RF Gateway 1 and Cisco RF Gateway 10 have also been tested for interoperability with Cisco DOCSIS 3.0 Downstream solution components.

Number of EQAM Devices Required

Each logical RF channel defined on the Wideband SPA must have one corresponding output QAM channel on an EQAM device. The number of EQAM devices required is determined by two factors:

- The number of logical RF channels in use on the Wideband SPAs in the CMTS. Each Wideband SPA supports up to 24 logical RF channels depending on how it is configured.
 - For Annex A and 256 QAM, each Wideband SPA supports 18 RF channels at full rate and up to 24 RF channels at less than full rate.
 - For all other cases, each Wideband SPA supports 24 RF channels.
- The number of output QAM channels on the EQAM device.

As an example, if a Cisco uBR10012 router (CMTS) contains two Wideband SPAs and each Wideband SPA is configured for 24 RF channels, the total number of RF channels that are in use is 48. Therefore, 48 output QAM channels are required on the EQAM devices.

The Cisco RF Gateway 1 supports 48 QAMs per unit and can, thus, support 2 SPAs. The Cisco RF Gateway 10 supports 48 QAMs per line card and also can support 2 SPA.

If more than two EQAM devices are required for two Wideband SPAs, a Gigabit Ethernet switch is needed to connect the SPAs to the EQAM devices.

Cisco RF Gateway 1

As the first release in the Cisco RF Gateway series of universal edge quadrature amplitude modulation (U-EQAM) products, the Cisco RF Gateway 1 introduces a fourth-generation, standards-based U-EQAM device for expansion of VoD, SDV, and high-speed data services.

The Cisco RF Gateway 1 is a highly dense, highly available and low-cost U-EQAM device, designed from the start to provide sufficient capacity to create a converged highly available Access/Edge.

Key features of the Cisco RF Gateway 1 include:

- Industry-leading scalability for a total stream processing capacity of 2048 streams per chassis
- Fully-redundant Gigabit Ethernet (GE) input ports (4 total for 2:2 redundancy) and redundant powering in just 1 RU
- Front-to-back airflow meets cable operator requirements and allows multiple RF Gateway 1 devices to be stacked.
- True U-EQAM for support of a multitude of applications: video (broadcast, SDV, SD/HD, MPEG-2, AVC) and IP (M-CMTS/DTI, DOCSIS 3.0)
- Fully frequency agile from 45 MHz to 1000 MHz
- Designed as a green EQAM with low power consumption
- Increased solution resiliency and reliability due to full integration with both the Cisco video and data converged architectures
- High QAM capacity enables highly efficient QAM sharing in a converged MPEG and IP environment
- High availability and control plane redundancy with the Cisco USRM
- Compliancy with ITU-T J.83 standard, Annex A (DVB), Annex B (ATSC), or Annex C (Japan)
- Internet Group Management Protocol Version 3 (IGMPv3) support
- Designed for pre-encryption or integrated encryption support
- Hot-swappable and auto-configurable QAM cards

Cisco RF Gateway 10

The Cisco RF Gateway 10 U-EQAM device provides the scalability and high-availability features required to support escalating QAM channel capacity needs. It allows your network to meet new levels of performance, capacity, power consumption, ease of management, and scalability.

The Cisco RF Gateway 10 features up to 480 QAM channels per chassis with the DS48 QAM line card, and the ability to scale with future QAM cards.

The Cisco RF Gateway 10 builds on the RF Gateway 1 and has the following advantages:

- Reduces operational cost of installing, configuring, and managing U-EQAM devices while increasing chassis capacity with field-upgradable components for simplified network build-out and increased service velocity
- Integrates with a wide variety of network architectures requiring advanced switching and routing features
- Reduces cost and complexity of WAN connections through the 10-Gigabit Ethernet interfaces
- Enables expansion in system capacity without RF network recabling
- Reduces time for upgrading and replacing system components
- Improves rack cabling efficiencies and access

Harmonic NSG 9000

The Harmonic Narrowcast Services Gateway (NSG) 9000 is one of the edge QAM devices that has been tested for interoperability with other solution components. The Harmonic NSG 9000 has three independent Gigabit Ethernet input interfaces that use SFP modules for fiber-optic and copper links. The Harmonic NSG 9000 edge QAM device is DOCSIS 3.0-compliant.

The Harmonic NSG 9000 edge QAM device provides scalable support for up to 72 QAM RF outputs. The chassis is fitted with a passive backplane, while all the processing and modulation functions are performed on retrievable modules. The chassis has nine QAM RF module slots. Each hot-swappable QAM module has two RF ports, and each port is capable of supporting up to four adjacent QAM channels (three channels in Annex A).

The Harmonic NSG 9000 edge QAM device is housed in a 2-rack unit chassis. The system can host two load-sharing AC or DC power supplies, which can be redundant to each other. For more detailed information about the Harmonic NSG 9000 edge QAM device go to the following URL:

<http://www.harmonicinc.com/>

Gigabit Ethernet Switch (Optional)

Optionally, A Gigabit Ethernet (GE) switch can be used to link the Wideband SPAs to edge QAM devices. The Gigabit Ethernet switch concentrates traffic from multiple Gigabit Ethernet links from the SPAs to a smaller number of Gigabit Ethernet links prior to fiber transport to the edge QAM devices.

A Gigabit Ethernet switch is required to connect Wideband SPAs to the EQAM devices in the following situations:

- If more than two EQAM devices are required for two Wideband SPAs
- If VoD traffic and the RF channels for wideband channels are mixed on the same EQAM device

DOCSIS Timing Interface Server

The DOCSIS Timing Interface (DTI) server provides DOCSIS clock generation and can act as a standalone module or lock to a GPS server or a network clock. It provides power and clock-card redundancy and ensures that the modular CMTS core, edge QAM, and upstream are synchronized to nanosecond levels to support the existing DOCSIS requirements for frequency and time stamps that existed in the traditional CMTS. Additionally, the modular CMTS core is synchronized to the edge QAM to schedule, correct, and insert MPEG time stamps for video. For additional information on the Symmetricom DTI server, go to www.symmetricom.com.

The following configurations are required for a reliable and scalable DTI-server solution:

- The M-CMTS devices should have two DTI ports, where one port serves as a backup during cable restructuring or a cable failure.
- The DTI servers, power supplies, and clock cards must have internal redundancy. This ensures that the DTI clients are not forced to switch or do not fail if only one port is used.
- The DTI server must support multiple configurations, such as, optional power supply, clock card, GPS, and network time protocol (NTP) redundancies.

Symmetricon TimeCreator 1000

The Symmetricon TimeCreator 1000 DTI server delivers a precise time and frequency synchronization between the modular CMTS and the edge QAM devices. The Symmetricon TimeCreator 1000 is a DTI Server with optional GPS traceability, redundant clock cards, redundant power supplies, and an NTP server option.

The Symmetricon TimeCreator 1000 integrated DTI Server capabilities ensure that the M-CMTS core, EQAM, and upstream are synchronized to nanosecond levels to support the existing DOCSIS requirements for frequency and time stamps that existed in the traditional CMTS. With the Symmetricon TimeCreator 1000 in an M-CMTS architecture, a cable modem receives its synchronization from the EQAM so that it is synchronized to other cable modems to properly transmit to the upstream burst receiver. Additionally, the M-CMTS core is synchronized to the EQAM to schedule, correct, and insert MPEG time stamps for video.

Wideband Cable Modems

The Cisco DOCSIS 3.0 Downstream Channel supports the following wideband cable modems:

- [Scientific Atlanta DPC3010 Wideband Cable Modem, page 4-16](#)
- [Linksys WCM300 Wideband Cable Modem, page 4-16](#)
- [Scientific Atlanta DPC2505 and EPC2505 Wideband Cable Modems, page 4-17](#)

Table 4-6 quantifies the number of upstream and downstream channels of some cable modems capable of downstream or upstream bonding, or both:

Table 4-6 Supported Number of Upstream and Downstream Channels of

Modem Type	Number of Downstream Channels	Number of Upstream Channels
SA DPC3825 Residential Gateway	8	4
SA DPC3925 Residential Gateway with 2 voice ports	8	4
SA DPQ3925 Residential Gateway with 2 voice ports and backup power	8	4
SA DPC3212 with embedded digital voice adapter	8	4
SA DPC 3010	8	4
SA DPC 3000	4	4
Linksys WCM300	9	1
SA DPC2505	3	1

*Cisco Cable Modems***Scientific Atlanta DPC3010 Wideband Cable Modem**

When used with the Cisco uBR10012 CMTS, the Scientific Atlanta DPC3010 wideband cable modems can receive traffic on multiple wideband channels simultaneously where each wideband channel consists of up to eight bonded downstream RF channels (6 MHz Annex B and 8 MHz Annex A channels are supported). One of the RF channels from the Wideband SPA serves as the primary downstream channel.

The Scientific Atlanta DPC3010 cable modem has two tuners, each of which handles four RF channels. The 4 RF channels per tuner must be contiguous within a 32 MHz window.

The Scientific Atlanta DPC3010 is DOCSIS 3.0-compatible and can be used in this mode. The modem is also backward compatible with existing DOCSIS 1.x networks (for example, if the modem is connected to a non-wideband Cisco CMTS or to a non-Cisco CMTS).

Linksys WCM300 Wideband Cable Modem

When used with the Cisco uBR10012 CMTS, the Linksys WCM300-NA (for DOCSIS), WCM300-EURO (for EuroDOCSIS), and WCM300-JP (for J-DOCSIS) wideband cable modems support the acquisition of up to three wideband (bonded) channels: one primary bonded channel and two secondary bonded channels.

**Note**

Cisco IOS Release 12.3(21a)BC3 through Cisco IOS Release 12.3BC are required for support of the Linksys WCM300-NA, WCM300-EURO, and WCM300-JP modems in wideband mode. Cisco support for the Linksys WCM300 ends at Cisco IOS Release 12.3(23)BC.

For each wideband channel, the Linksys WCM300 wideband cable modem receives one or more bonded RF channels. The Linksys WCM300 software provides the wideband cable modem with a 50 MHz capture window to receive up to eight downstream channels at 6 MHz per channel or six downstream channels at 8 MHz per channel. The total of the RF channels in the primary and secondary bonded channels must comply with the 50 MHz capture-window limitation.

For wideband, the Linksys WCM300 wideband cable modem uses one or more bonded RF channels. For wideband, the Linksys WCM300 uses a primary downstream channel from an M-CMTS SPA, Cisco uBR-MC5X20, or Cisco uBR-MC20X20 line card to carry MAC management and signaling messages.

The Linksys WCM300 is DOCSIS 2.0-compatible and can be used in the DOCSIS 2.0 mode (for example, if the modem is connected to a non-wideband Cisco CMTS or to a non-Cisco CMTS). The modem is also backward compatible with existing DOCSIS 1.x networks.

The Linksys WCM300-JP supports J-DOCSIS channel operation—6-MHz Annex B extension support with a downstream frequency range of 88 MHz to 860 MHz and an upstream frequency range of 5 MHz to 65 MHz.

Separate Linksys WCM300 software images are used for DOCSIS and EuroDOCSIS channel widths. Downstreams in the wideband channel support 64 QAM and 256 QAM.

The Linksys WCM300 wideband cable modem has two ports—an F-type 75-ohm connector that provides a cable network attachment, and an RJ-45 port that provides a 10/100/1000-Mbps Ethernet connection to the home or business. For more information about the Linksys WCM300 wideband cable modem, go to:

http://www.cisco.com/en/US/products/ps8426/tsd_products_support_series_home.html

Scientific Atlanta DPC2505 and EPC2505 Wideband Cable Modems

When used with the Cisco uBR10012 CMTS, the Scientific Atlanta DPC2505 and EPC2505 (for EuroDOCSIS) wideband cable modems can receive one wideband channel, which consists of up to three bonded downstream RF channels from the SPA at 6 MHz per channel or at 8 MHz per channel. One of the RF channels from the Wideband SPA serves as the primary downstream channel.

The Scientific Atlanta DPC2505 is DOCSIS 3.0-compatible and can be used in this mode (for example, if the modem is connected to a non-wideband Cisco CMTS or to a non-Cisco CMTS). The modem is also backward compatible with existing DOCSIS 1.x networks.

The Scientific Atlanta DPC2505 and EPC2505 wideband cable modems have an F-type 75-ohm connector for a cable network attachment and two data ports—a Gigabit Ethernet port with Autonegotiate and Auto-MDIX, and a USB 2.0 port.

The Scientific Atlanta DPC2505 and EPC2505 also feature front-panel LEDs to provide visual feedback of real-time data transmission and operational status. The Scientific Atlanta DPC2505 features WebWizard, a browser-based user interface, which is a powerful tool that facilitates installation and troubleshooting. WebWizard eliminates the need to load set-up software on the customer premises equipment (CPE).

Wideband CMTS Redundancy and Resiliency

The Cisco uBR10012 wideband CMTS and related hardware and software provide redundancy and resiliency to the Cisco DOCSIS 3.0 Downstream Solution. Reliable, fault-tolerant components and resilient network technologies automatically identify and overcome failures. The following sections describe the wideband CMTS redundancy and resiliency features:

- [Route Processor Redundancy and Resiliency, page 4-18](#)
- [Cisco uBR10-MC5X20 Line Card Redundancy, page 4-19](#)
- [Cisco uBR-MC3GX60V Line Card Redundancy, page 4-20](#)
- [Wideband SPA Redundancy, page 4-21](#)
- [Wideband Channel Resiliency, page 4-21](#)
- [Edge QAM Redundancy, page 4-21](#)

Table 4-7 summarizes redundancy and resiliency support for the Cisco uBR10012 base system recommended hardware configuration (see Table 4-1 and Table 4-3). If component failure occurs, the components listed in Table 4-7 can be replaced without interrupting system operations as long as the redundant components are correctly installed and configured before the component failure occurs.

Table 4-7 Cisco uBR 10012 Base System Redundancy and Resiliency

Modular CMTS Component	Redundancy and Resiliency Summary
PRE route processors	Two PRE modules. The Route Processor Redundancy Plus (RPR+) feature and DOCSIS Stateful Switchover (DSSO) provide the PRE modules with fast route processor failover without DOCSIS line card reboot.
Redundant power supplies	Two DC or AC power entry modules (PEMs). If one PEM fails, the other PEM immediately begins providing the required power to the system.

Table 4-7 Cisco uBR 10012 Base System Redundancy and Resiliency

Modular CMTS Component	Redundancy and Resiliency Summary
Redundant DOCSIS Timing and Control Cards (DTCC)	The two DTCCs monitor priority information of each other so that if the active card fails, the active card role is transferred to the redundant backup card without loss of data.
Fan assembly module	The fan assembly has four internal fans. If a single fan fails and the fan assembly is still able to cool the chassis, the router will continue to function until the fan assembly module can be replaced.
Redundant Half-Height Gigabit Ethernet (HHGE) line cards	Multiple HHGE line cards to support connectivity to multiple destinations and to provide network layer redundancy.
Cisco uBR10-MC5X20S/U/H and Cisco uBR10-MC5X20U-D cable interface line cards	N+1 Redundancy provides automatic switchover and recovery for cable modems connected as DOCSIS 1.x or DOCSIS 2.0 modems in the event that there is a cable interface line card failure.
Cisco UBR-MC20X20V cable interface line cards	N+1 Redundancy provides automatic switchover and recovery for cable modems connected as DOCSIS 1.x, DOCSIS 2.0 or DOCSIS 3.0 modems in the event that there is a cable interface line card failure.
Cisco uBR-MC3GX60 cable interface line card	Beginning with Cisco IOS Release 12.2(33)SCE1, the N+1 redundancy feature including DEPI redundancy is supported on the Cisco uBR-MC3GX60V cable interface line card..
M-CMTS line card DEPI Link	Both the M-CMTS SPA and Cisco uBR-MC3GX60V line card support the optional use of dual Gigabit Ethernet ports for link level redundancy. The line card detects link failure and automatically uses the redundant link if it is present.

For complete information on the Cisco uBR10012 router hardware redundancy, see the *Cisco uBR10012 Universal Broadband Router Hardware Installation Guide* at the following URL:

<http://www.cisco.com/en/US/docs/cable/cmts/ubr10012/installation/guide/hig.html>

Route Processor Redundancy and Resiliency

The Route Processor Redundancy Plus (RPR+) feature and DOCSIS Stateful Switchover (DSSO) in the Cisco IOS software provide the Cisco uBR10012 router PRE route processors with fast route processor failover without DOCSIS line card reboot.

Route Processor Redundancy Plus

The RPR+ feature enables the Cisco uBR10012 router to use two PRE route processors in a redundant configuration—an active and standby PRE module. If the active PRE module fails, or is removed from the system, the standby PRE detects the failure and initiates a switchover. During a switchover, the standby PRE assumes control of the router, connects with the network interfaces, and activates the local network management interface and system console.

Using the RPR+ feature, the standby PRE module is fully initialized and configured. This allows RPR+ to dramatically shorten the switchover time if the active PRE fails, or if a manual switchover is performed. Because both the startup configuration and running configuration are continually synchronized from the active to the standby PRE route processor, line cards are not reset during a switchover. The interfaces remain up during this transfer, so neighboring routers do not detect a link flap (that is, the link does not go down and come back up).

The RPR+ feature does not require a full reboot of the system to perform a failover. When the system is originally initialized, the secondary PRE module performs an abbreviated initialization routine—the module performs all self-checks and loads the Cisco IOS software, but instead of performing normal systems operations, it begins monitoring the primary PRE module. If the secondary PRE module detects a failure in the primary module, it can quickly assume the primary responsibility for systems operations.

During RPR+ switchover, wideband cable modems on the CMTS stay online. The MAC state for the wideband cable modem remains online for a modem registered as a DOCSIS 2.0 modem, or w-online for a modem registered as a wideband cable modem.

DOCSIS Stateful Switchover

DOCSIS Stateful Switchover (DSSO) increases service uptime by instantaneously switching over between dual route processors should one processor fail. Switchover takes place without resetting or reloading line cards or affecting related subsystems or processes. The advantage of DSSO with RPR+ is that a switchover between the primary and standby RP does not require the cable interfaces to be reset, nor do the modems reregister or go offline. Furthermore, the cable modems retain their service IDs (SIDs) through the switchover.

For more information on PRE and RPR+ and DOCSIS Stateful Switchover, see the document *Route Processor Redundancy Plus on the Cisco uBR10012 Universal Broadband Router* at the following URL: http://www.cisco.com/en/US/docs/ios/cable/configuration/guide/u10k_rtpro_red_plus_ps2209_TSD_Products_Configuration_Guide_Chapter.html

Cisco uBR10-MC5X20 Line Card Redundancy

The Cisco uBR10012 router supports N+1 Redundancy on the cable interface line cards including the Cisco uBR10-MC5X20S/U/H and Cisco uBR10-MC5X20U-D cable interface line cards, which are used in the Cisco Cable Wideband solution.

N+1 Redundancy can help limit customer premises equipment (CPE) downtime by enabling robust automatic switchover and recovery in the event that there is a localized system failure. Upon switchover, N+1 Redundancy uses Hot Standby Connection-to-Connection Protocol (HCCP) to synchronize the configurations and current status between working interfaces and the protect interfaces. This makes the configuration of both easier and switchover times faster.

A single Cisco uBR10012 CMTS can support up to 8 Cisco uBR10-MC5X20S/U/H and Cisco uBR10-MC5X20U-D cable interface line cards, each featuring 5 downstream and 20 upstream cable interfaces for a total of up to 40 downstream and 160 upstream interfaces in the chassis. The

eight-card 7+1 Redundancy scheme for the Cisco uBR10012 router supports redundancy for the cable interface line cards installed in a fully populated Cisco uBR10012 chassis. Other redundancy schemes are designed to support partial cable interface line card populations in a Cisco uBR10012 chassis.

N+1 Redundancy is made possible with the addition of a Cisco RF Switch to your cable headend network. A single Cisco RF Switch can be connected to the Cisco uBR10012 CMTS, allowing deployment of an N+1 Redundancy scheme where one protect cable interface line card supports from one to seven working cable interface line cards in the same chassis.

**Note**

Both 7+1 Redundancy and N+1 Redundancy switchover are supported *only for cable modems connected as DOCSIS 1.x, DOCSIS 2.0 and DOCSIS 3.0 modems*. During 7+1 Redundancy and N+1 Redundancy switchover, cable modems that are connected in the wideband mode using the failed cable interface line card lose connectivity. Manual intervention (for example, use of the **clear cable modem wideband reset** command) may be required to bring wideband cable modems wideband-online mode again.

For more information on N+1 redundancy for Cisco uBR10012 line cards, see the *Cisco Cable Modem Termination System Feature Guide*.

Cisco uBR-MC3GX60V Line Card Redundancy

**Note**

Beginning with Cisco IOS Release 12.2(33)SCE1, the N+1 redundancy feature including DEPI redundancy is supported on the Cisco uBR-MC3GX60V cable interface line card.

Similar to Cisco uBR-MC5X20 line card, Cisco uBR10012 router supports N+1 redundancy on the Cisco uBR-MC3GX60V line card. A single Cisco uBR10012 CMTS can support up to eight Cisco uBR-MC3GX60V cable interface line cards, each featuring 72 downstream and 60 upstream cable interfaces for a total of up to 576 downstream and 480 upstream interfaces in the chassis. The eight-card 7+1 Redundancy scheme for the Cisco uBR10012 router supports redundancy for the cable interface line cards installed in a fully populated Cisco uBR10012 chassis. Other redundancy schemes are designed to support partial cable interface line card populations in a Cisco uBR10012 chassis.

For more information on N+1 redundancy for Cisco uBR-MC3GX60V line cards, see the *Cisco Cable Modem Termination System Feature Guide*.

For more information on how to configure the N+1 redundancy for Cisco uBR-MC3GX60V line cards, see *Configuring the Cisco uBR-MC3GX60V Cable Interface Line Card* at the following URLs:

http://www.cisco.com/en/US/docs/interfaces_modules/cable/broadband_processing_engines/ubr_mc3gx60v/configuration/guide/mc3g60_cfg.html

Cisco uBR-MC3GX60V Line Card Redundant Gigabit Ethernet Ports

The Cisco uBR-MC3GX60V has three pairs of active and redundant Gigabit Ethernet ports (a total of six ports). The ports carry downstream traffic and are directly connected to the external edge QAM device or indirectly through and intermediary switch or network. If the link state of both Gigabit Ethernet ports is up, port 0 comes up as the active port and Port 1 will be the redundant port. If the link state of Port 0 is not up, Port 1 comes up as the active port.

The **show controllers modular-cable** command shows the current state of the Cisco uBR-MC3GX60V Gigabit Ethernet ports. With the Cisco IOS CLI, the Gigabit Ethernet ports are not specified as individual Gigabit Ethernet interfaces because the ports work in tandem as a redundant pair.

For Cisco DOCSIS 3.0 Downstream Solution, if a Gigabit Ethernet link fails, automatic failover to a redundant link is supported.

Wideband SPA Redundancy

The Wideband SPA provides redundancy and resiliency through a number of mechanisms. The Wideband SIP and Wideband SPAs support online insertion and removal (OIR) and are hot-swappable.

Wideband SPA Redundant Gigabit Ethernet Ports

The Wideband SPA has one active and one redundant Gigabit Ethernet port that is used to send traffic to the external edge QAM device. If the link state of both Gigabit Ethernet ports is up, Port 0 comes up as the active port and Port 1 will be the redundant port. If the link state of Port 0 is not up, Port 1 comes up as the active port.

The **show controllers modular-cable** command shows the current state of the Wideband SPA Gigabit Ethernet ports. With the Cisco IOS CLI, the Wideband SPA Gigabit Ethernet ports are not specified as individual Gigabit Ethernet interfaces because the ports work in tandem as a redundant pair.

For Cisco DOCSIS 3.0 Downstream Solution, if a Gigabit Ethernet link from the Wideband SPA to the edge QAM device fails, automatic failover to a redundant link is not supported.

Wideband Channel Resiliency

Wideband Channel Resiliency is a Cisco CMTS feature supported on deployments using any of the Cisco wideband capable line cards. The feature utilizes DOCSIS cable modem status messaging to monitor the cable plant on a per-RF channel basis.

If a wideband channel fails, the wideband cable modem goes offline and reregisters:

- If another wideband channel is available for the service, the wideband cable modem tries that channel and comes online.
- If no other wideband channel is available, the wideband cable modem comes online in DOCSIS 1.x or DOCSIS 2.0 mode.

If a sufficient number of modems report channel failure, then the CMTS will disable the channel to keep the associated bonding groups up and passing traffic going. For more information, see *Wideband Channel Resiliency Feature Guide* at the following URL:

http://www.cisco.com/en/US/docs/ios/cable/configuration/guide/ubr_wm_resiliency_ps2209_TSD_Products_Configuration_Guide_Chapter.html

Edge QAM Redundancy

For information on redundancy for the Harmonic NSG 9000, see the vendor documentation for that device. This section describes one mechanism for redundancy that is available with Harmonic NSG 9000.

Cisco RF Gateway 10 supports in-chassis redundancy. Cisco RF Gateway 1 supports Edge QAM redundancy through external RF Signal Manager switches. For more information, see the Cisco RF Gateway documentation at the following URL:

http://www.cisco.com/en/US/products/ps8360/tsd_products_support_series_home.html

Edge QAM Redundant Gigabit Ethernet Ports

The Harmonic NSG 9000 has redundant Gigabit Ethernet ports that are used to receive downstream traffic from the Wideband SPA. If the link state of the active Gigabit Ethernet port of the Wideband SPA goes down, the redundant link from the Wideband SPA to the edge QAM device becomes the active link. On the CMTS, the **show controllers modular-cable** command shows the current state of the Wideband SPA Gigabit Ethernet ports, which connect to the EQAM device.

Cisco RF Gateway 1 and Cisco RF Gateway 10 both support Gigabit Ethernet redundancy. For more information on the full description of input redundancy options, see the Cisco RF Gateway documentation at the following URL:

http://www.cisco.com/en/US/products/ps8360/tsd_products_support_series_home.html

Where to Find Information on Solution Hardware Components

Table 4-8 provides a list of the hardware installation documents that are most relevant to the Cisco DOCSIS 3.0 Downstream Solution components. The complete list of Cisco uBR10012 hardware installation and upgrade guides is available at:

http://www.cisco.com/en/US/products/hw/cable/ps2209/prod_installation_guides_list.html

Table 4-8 Cisco Hardware Components: Where to Find More Information

Solution Component	Where to Find More Information
Cisco uBR10012 chassis	<i>Regulatory Compliance and Safety Information for the Cisco uBR10012 Universal Broadband Router</i>
Performance Routing Engine (PRE)	<i>Cisco uBR10012 Universal Broadband Router Hardware Installation Guide</i> (full installation guide)
DOCSIS Timing and Control Card (DTCC)	<i>Cisco uBR10012 Universal Broadband Router Hardware Installation Guide</i> (quick start guide)
DC power entry modules (DC PEMs)	
AC power entry modules (AC PEMs)	
Fan assembly module	
LCD module	
Cisco uBR10-MC5X20S/U/H and Cisco uBR10-MC5X20U-D cable interface line cards	<i>Cisco uBR10012 Universal Broadband Router Hardware Installation Guide</i> (full installation guide) <i>Cisco uBR10-MC5X20S/U/H Cable Interface Line Cards - Hardware Installation Guide</i> <i>Cabling the Cisco uBR10-MC5X20S/U/H Cable Interface Line Card with Universal Cable Holder—UCH1</i> <i>Cabling the Cisco uBR10-MC5X20S/U/H Cable Interface Line Card with Universal Cable Holder—UCH2</i>
Cisco uBR10-MC3GX60V cable interface line card	<i>Cisco uBR10012 Universal Broadband Router Hardware Installation Guide</i> (full installation guide) <i>Cisco uBR-MC3GX60V Cable Interface Line Cards - Hardware Installation Guide</i> <i>Configuring the Cisco uBR-MC3GX60V Cable Interface Line Card</i>

Table 4-8 Cisco Hardware Components: Where to Find More Information (continued)

Solution Component	Where to Find More Information
Half-Height Gigabit Ethernet (HHGE) network uplink line card	<i>Cisco uBR10012 Universal Broadband Router Hardware Installation Guide</i> (full installation guide) <i>Cisco uBR10012 Universal Broadband Router Gigabit Ethernet Half-Height Line Card Installation</i>
Wideband SPA Interface Processor (SIP) Wideband Shared Port Adapter (SPA)	<i>Cisco uBR10012 Universal Broadband Router SIP and SPA Hardware Installation Guide</i> <i>Cisco uBR10012 Universal Broadband Router SIP and SPA Software Configuration Guide</i>
Gigabit Ethernet Shared Port Adapters (SPA)	<i>Cisco uBR10012 Universal Broadband Router SIP and SPA Hardware Installation Guide</i>
Cisco RF Gateway documentation	http://www.cisco.com/en/US/products/ps8360/tsd_products_support_series_home.html
Symmetricon TimeCreator 1000	Refer to the vendor documentation.
Harmonic NSG 9000 edge QAM device	Refer to the vendor documentation.
Scientific Atlanta DPC2505 and EPC2505 wideband cable modems	Refer to the vendor documentation.
Linksys WCM300-NA, WCM300-EURO, and WCM300-JP wideband cable modems	<i>Release Notes for Linksys WCM300 Cable Modem Software</i> <i>Cisco uBR10012 Universal Broadband Router SIP and SPA Software Configuration Guide</i>



Cisco DOCSIS 3.0 Downstream Solution Architecture

This chapter explains the architecture used for the Cisco DOCSIS 3.0 Downstream (DS) Solution in Cisco IOS Releases 12.2(23)BC, Cisco IOS Release 12.3(33)SCB and later releases.

This chapter contains the following topics:

- [Modular CMTS, page 5-41](#)
- [GE Switch Functionality, page 5-46](#)
- [DOCSIS Timing Interface Server Functionality, page 5-46](#)
- [Edge QAM Device Functionality, page 5-47](#)
- [Integrated CMTS, page 5-47](#)
- [Wideband Cable Modem Functionality, page 5-48](#)
- [DOCSIS 3.0 Wideband Channel Support, page 5-62](#)
- [Support for Cisco SIP-600 and Gigabit Ethernet SPAs, page 5-65](#)
- [Wideband Modem Resiliency, page 5-66](#)
- [Dynamic Bandwidth Sharing, page 5-66](#)
- [DOCSIS WFQ Scheduler, page 5-67](#)
- [Voice Support on Wideband Modems, page 5-67](#)
- [DOCSIS 3.0 Downstream Bonding for Bronze Certification, page 5-68](#)

Modular CMTS

The Cisco DOCSIS 3.0 DS Solution, deploys along with the modular CMTS (M-CMTS) architecture. With the M-CMTS architecture, the DS physical layer (PHY) is located in a separate network element called the Edge quadrature amplitude modulation (QAM) (QAM) device, while the packet processing at Layer 2 (DOCSIS) and above is done in the M-CMTS core.

The CableLabs specification for the M-CMTS architecture defines changes to the Edge QAM device, that requires it to be both DOCSIS-aware and synchronized to the DOCSIS subsystem. The Cisco implementation of the M-CMTS architecture meets this requirement by using the DTCC to acquire timing information from the DTI server and then distribute it within the CMTS.

Figure 5-1 shows the M-CMTS architecture used in the Cisco DOCSIS 3.0 DS Solution, with a Cisco uBR-MC3GX60V cable interface line card and a single wideband channel. In this example, eight DS RF channels are bonded together into one wideband channel. The Gigabit Ethernet (GE) switch is optional. The Wideband Gigabit Ethernet Interface can be connected directly to the GE Interface on the Edge QAM.

Figure 5-1 Cisco Cable Wideband M-CMTS Architecture Using the uBR-MC3GX60V Line Card

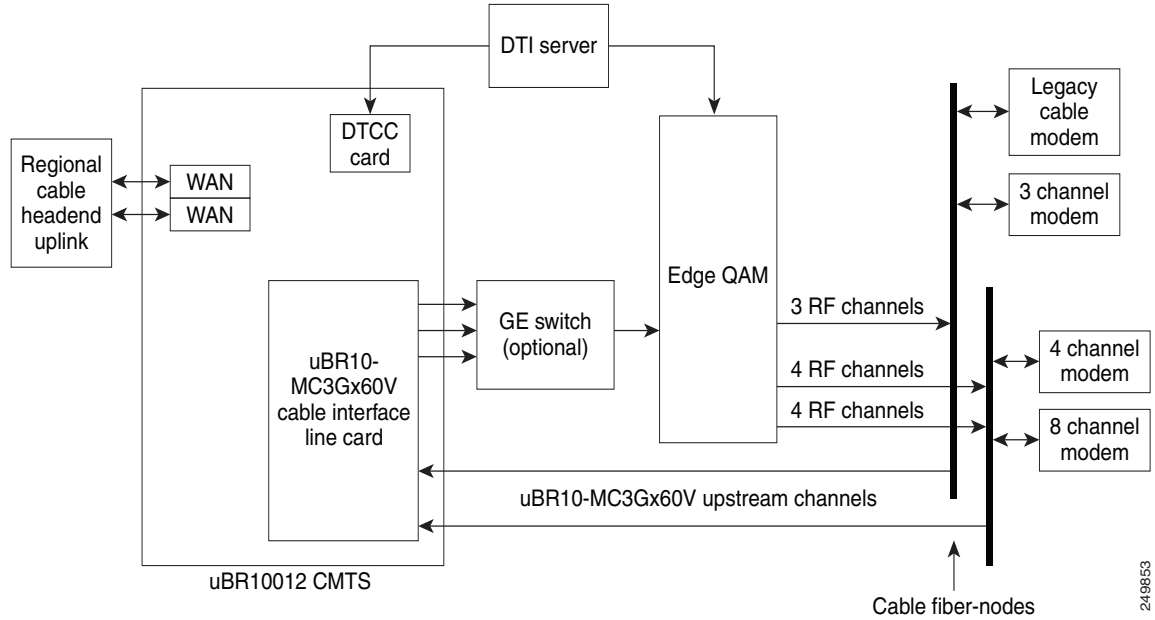

249853

Figure 5-2 shows the M-CMTS architecture used in the Cisco DOCSIS 3.0 DS Solution, with a single wideband channel. In this example, three DS RF channels are bonded together into one wideband channel. The GE switch is optional. The Wideband SPA Gigabit Ethernet Interface can be connected directly to the GE Interface on the Edge QAM.

Figure 5-2 Cisco Cable Wideband M-CMTS Architecture using uBR10-MC5X20 line card

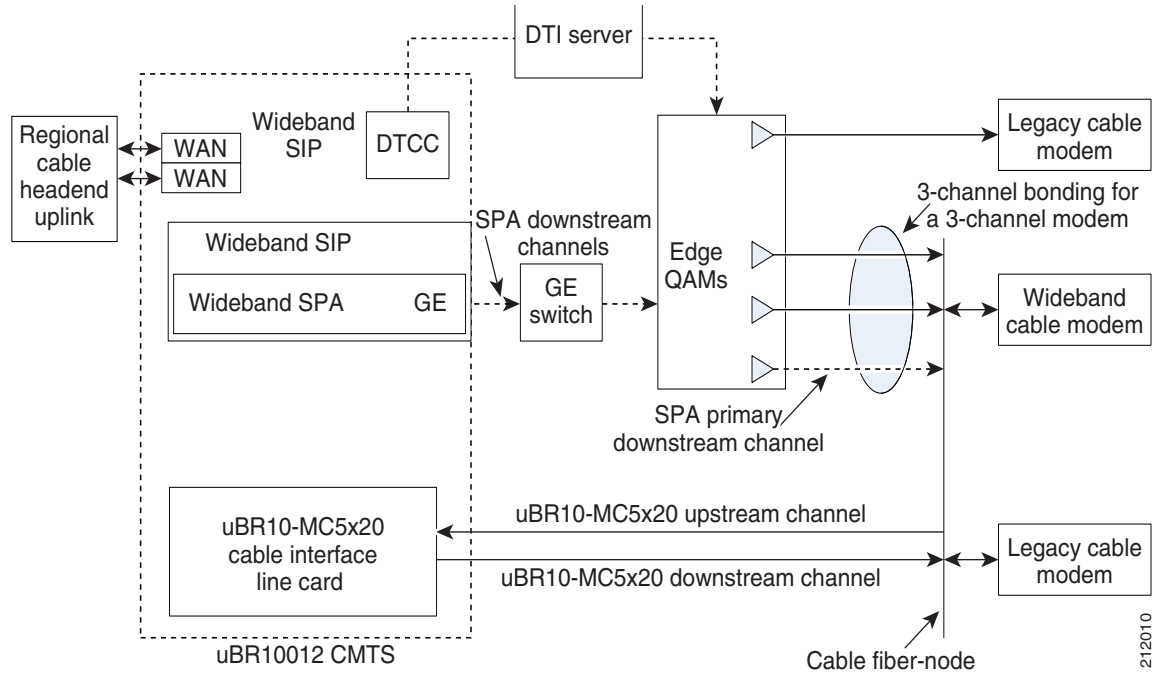

Starting with Cisco IOS Release 12.2(33)SCG, Cisco Wideband SPA and Cisco uBR-MC3GX60V cable interface line card can share DS channels, and therefore can coexist on a single chassis. [Figure 5-3](#) shows the M-CMTS architecture used in the Cisco DOCSIS 3.0 DS solution, with Cisco Wideband SPA and Cisco uBR-MC3GX60V cable interface line card. In this example, three DS RF channels are bonded together into one wideband channel. The GE switch is optional. The Wideband SPA Gigabit Ethernet interface can be connected directly to the GE interface on the Edge QAM.

Figure 5-3 Cisco Cable Wideband M-CMTS Architecture Using Cisco Wideband SPA and Cisco uBR-MC3GX60V line card

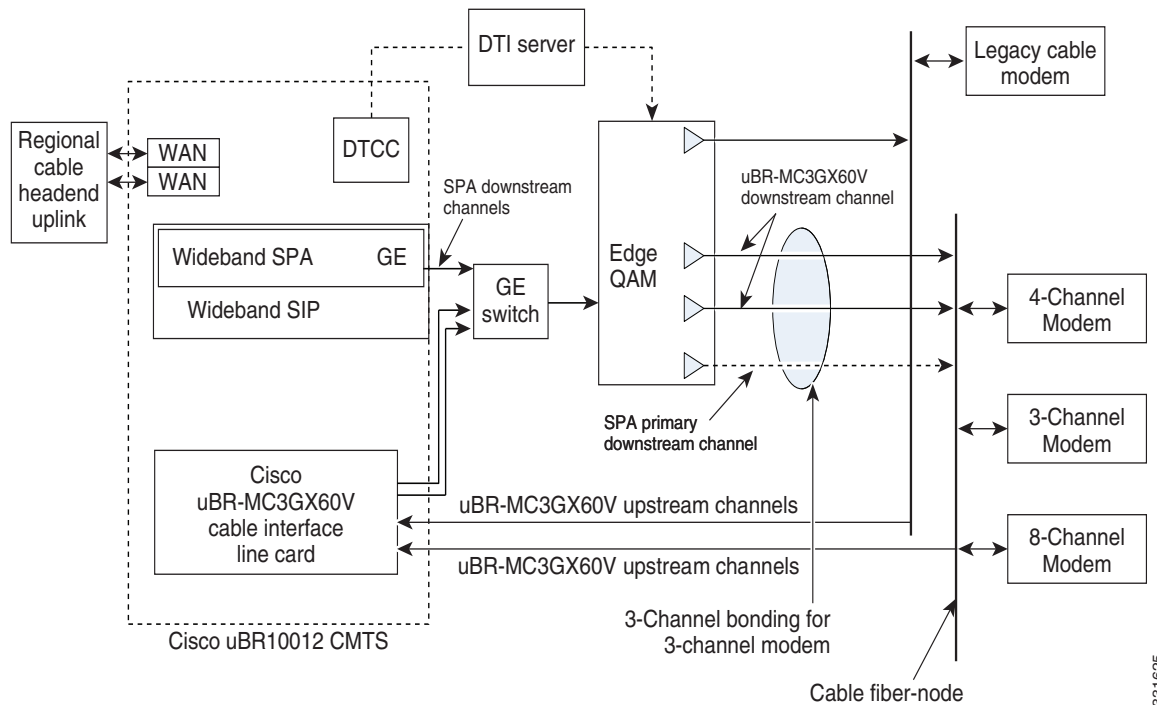

In the M-CMTS architecture used for the Cisco DOCSIS 3.0 DS Solution, traditional Cisco CMTS functionality is divided into three network elements and an interface, as specified below:

- **M-CMTS core**—Contains the traditional functionality of a CMTS except for the DS PHY. The M-CMTS Core provides CMTS functionality, such as DOCSIS Media Access Control (MAC) and upstream (US) QPSK and QAM demodulation. DOCSIS MAC includes US and DS packet transmission services, and MAC management message exchanges with the cable modems. In the Cisco DOCSIS 3.0 DS Solution, the Cisco uBR10012 router is the M-CMTS core device. The M-CMTS core acquires the required timing from the DTI server using its DTCC, which is connected to the timing server.
- **Edge QAM (EQAM) device**—Connects to the M-CMTS core as well as the DTI server and contains PHY-related hardware, such as QAM modulators. For input, the EQAM device communicates with the M-CMTS through redundant GE interfaces. For output, the EQAM device has multiple QAM modulators and RF upconverters that connect to a hybrid fiber-coaxial (HFC) network. In the Cisco DOCSIS 3.0 DS Solution, the Harmonic Narrowcast Services Gateway (NSG) 9000 EQAM, the Cisco RF Gateway 1, and Cisco RF Gateway 10 EQAM devices are tested for interoperability with solution components. For more information on EQAM, see [Edge QAM Device Functionality, page 5-47](#).
- **DOCSIS Timing Interface (DTI) server**—Connects to the M-CMTS core via the DTCC as well as the EQAM device. The DTI server provides DOCSIS clock generation in an M-CMTS architecture. It ensures that the DOCSIS time-stamp and frequency between M-CMTS core, EQAM, and US are synchronized to nanosecond levels. For more information on DTI server, see [DOCSIS Timing Interface Server Functionality, page 5-46](#)
- **Downstream External PHY Interface (DEPI)**—Interface between the M-CMTS core and the EQAM. This interface is an L2TPv3 tunnel between the CMTS DOCSIS MAC and the PHY.

Benefits of M-CMTS Architecture

Some of the benefits of a modular CMTS architecture are described in these sections:

- [Cost-Effective Architecture, page 5-45](#)
- [Multiservice Architecture, page 5-45](#)

Cost-Effective Architecture

The Cisco DOCSIS 3.0 DS solution can use the existing network of the Multiple Systems Operator (MSO). Deployed Cisco uBR10012 routers, that are used as a DOCSIS 1.x and DOCSIS 2.0 CMTS, can be upgraded to a M-CMTS by adding on hardware (the Cisco uBR-MC3GX60V, or Cisco Wideband SIP and SPA, or both) and upgrading Cisco IOS software. Some existing external QAM array devices used for the Video on Demand (VoD), with a software upgrade may be able to be deployed as the EQAM device. For EQAM devices that have been tested for interoperability, see [External Edge QAM Device](#).

MSOs can repurpose their existing network infrastructure, including existing fiber nodes, for wideband cable. The benefits of the M-CMTS architecture include:

- Lower cost, lower power requirements, and higher density of EQAM devices.
- Less-expensive external QAM arrays for DS channels. This is more cost effective than locating the DS QAM channels in the CMTS chassis.
- Operating cost is saved by avoiding rewiring and moving customers to new systems.

With traditional CMTS architecture, adding DS RF channels for a wideband channel would also mean adding multiple USs. With the M-CMTS SPA architecture, multiple DS RF channels can be added without any additional USs. This independent scaling of DS channels makes the Cisco DOCSIS 3.0 DS Solution more cost effective.

Multiservice Architecture

With the M-CMTS architecture, the use of external EQAM devices allows MSOs to use the same network resources for a VoD network and a Cisco wideband cable network. With updated firmware, some EQAM devices can be used for VoD and for wideband channels, however individual output QAM channels in the device cannot be shared.

The wideband channel, comprising of one or more RF channels on the EQAM device, is used for DS data traffic. The US channels on the Cisco uBR-MC3GX60V or Cisco uBR10-MC5X20 cable interface line cards are used for US traffic. The DTI server is used for timing signaling messages.

In the Cisco DOCSIS 3.0 DS solution, traditional DOCSIS 1.x and DOCSIS 2.0 services are supported by the Cisco CMTS on either the traditional Cisco uBR10-MC5X20 cable interface DS channels or the edge QAM DS channels.

The DOCSIS 3.0 DS solution also supports multiservice architecture (see [Figure 5-4](#)) with converged IP triple play (voice, data, and video services) on wideband channels, which includes support for DOCSIS 3.0 services.

All services use the same IP/DOCSIS network and share the same RF network resources.

Figure 5-4 M-CMTS Multiservice Architecture

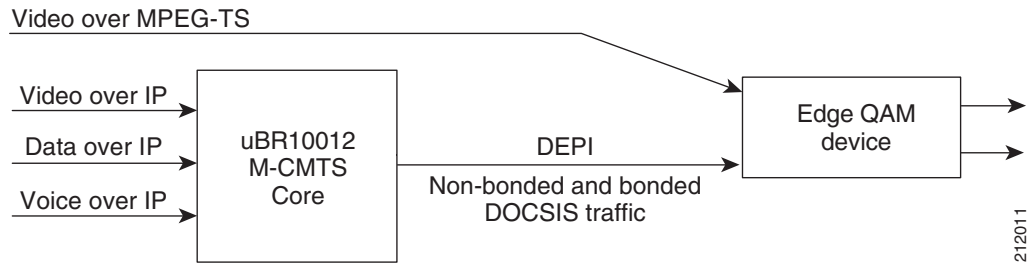

GE Switch Functionality

The GE switch is an optional device that receives DS packets from the Cisco uBR-MC3GX60V line card or Cisco Wideband SPA, and passes the packets to the EQAM device. The Gigabit Ethernet switch is used to:

- Concentrate traffic from multiple Gigabit Ethernet links to a smaller number of Gigabit Ethernet links prior to fiber transport to the EQAM devices
- Provide 1+1 or N+1 redundancy for DS Gigabit Ethernet links
- Multiplex wideband DOCSIS traffic and video traffic onto the same EQAM devices

The GE Switch is required, in the M-CMTS DS solution, in the following scenarios:

- If more than two EQAM devices are required for two Wideband SPAs, a GE switch is needed to connect the SPAs to the EQAM devices.
- If VoD traffic and RF channels for wideband channels are mixed on the same EQAM device, a GE switch is required.

When an RF channel for a wideband channel is configured using Cisco IOS commands on the Cisco uBR10012 router, the **rf-channel** command with the **mac-address** keyword option specifies the MAC address for the next-hop interface on the switch if it is a Layer 2 GE switch. The **rf-channel** command with the **ip-address** keyword option specifies the IP address of the Gigabit Ethernet interface on the EQAM device. The MAC address on the switch and the IP address on the EQAM device are used to route DS traffic for the RF channel to the correct destinations.

DOCSIS Timing Interface Server Functionality

The DTI server interfaces with the EQAM devices and DTCC in the M-CMTS. It facilitates communication between M-CMTS, EQAM devices, and the cable modems by synchronizing timing and frequency between the three devices to nanosecond levels, supporting DOCSIS 3.0 standards. The M-CMTS core is synchronized to the EQAM device to schedule, correct, and insert MPEG time stamps for video. A cable modem receives its synchronization from the EQAM device so that it is synchronized to other cable modems to properly transmit to the US burst receiver.



Note

When the **cable clock dti** command or its **no** form is used to configure the DTI clock reference mode, the DTCC card on the Cisco uBR10012 router restart and the cable modems may re-initialize or re-register.

Edge QAM Device Functionality

The EQAM device receives wideband traffic as MPEG-TS over IP on its Gigabit Ethernet interfaces, encapsulated with L2TP as DEPI frames. The EQAM device extracts the MPEG-TS packets from the MPEG-TS over IP stream and routes them to the proper QAM RF outputs to the HFC plant for transmission to the wideband cable modem.

The EQAM devices are not involved in the active management of bandwidth or QoS for wideband channels. The EQAM devices are not aware of the IP addressing used by the wideband cable modems.

Each M-CMTS can support numerous EQAM devices if required. The DEPI interfaces with the EQAM device and M-CMTS and is used for encapsulation of frames in the DOCSIS-MPEG Transport mode over IP to forward packets for the QAM channels to a synchronous EQAM. Each DS channel associated with the EQAM is a narrowband channel and is referred to as a modular-cable interface. The modular-cable interface must forward traffic using DEPI.

The total bandwidth for a single QAM channel can be statically allocated between one or more wideband and narrowband channels. When a wideband channel is configured on the Cisco CMTS, the wideband channel uses multiple specified logical RF channels on the Cisco Wideband SPA. Each RF channel is associated with a QAM output on the EQAM device. The bandwidth of an RF channel can be divided between one or more wideband channels as long as the total allocated bandwidth for an RF channel (and QAM channel) does not exceed 100 percent. For more information about configuring RF channels, see the *Cisco uBR10012 Universal Broadband Router SIP and SPA Software Configuration Guide*.

The QAM channels on the EQAM device do not have to be adjacent channels. If some of the QAM channels have already been assigned for non-DOCSIS purposes, the Cisco DOCSIS 3.0 DS Solution uses the channels that are available. The system does impose certain constraints. For example, if the QAMs are frequency stacked, certain QAMs will have to be adjacent.

Integrated CMTS

Figure 5-5 shows the I-CMTS architecture used in the Cisco DOCSIS 3.0 DS Solution.

Figure 5-5 Cisco Cable Wideband I-CMTS Architecture Using the UBR-MC20X20V Line Card

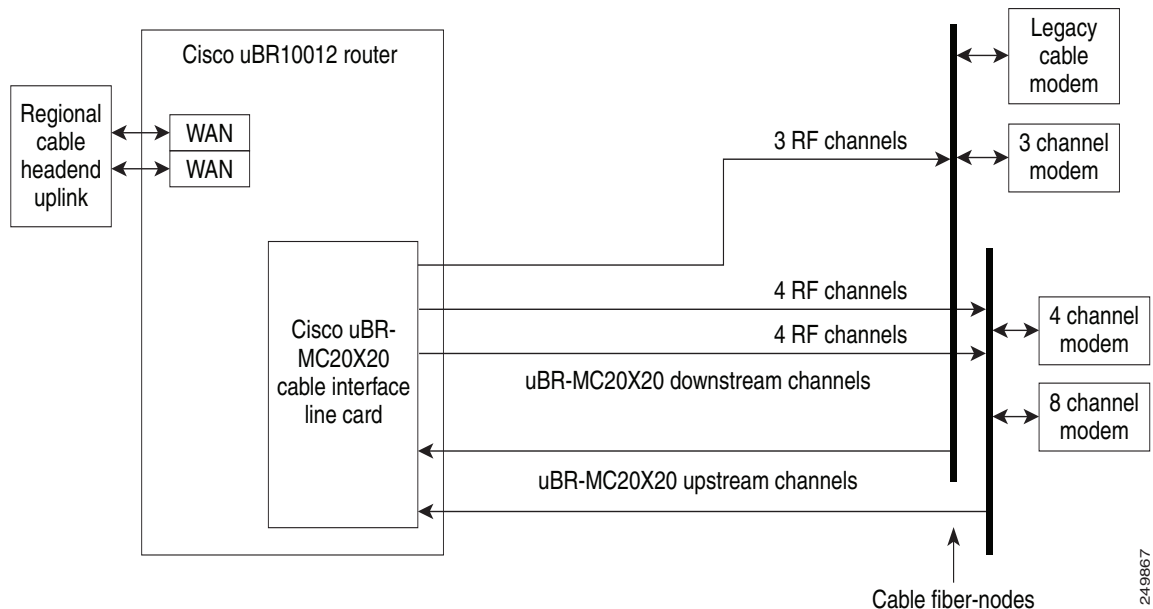

249867

Benefits of I-CMTS Architecture

Some of the benefits of I-CMTS architecture:

- I-CMTS is a simpler solution than M-CMTS. I-CMTS provides a simpler solution for MSOs upgrading a non-bonding cable plant, based on Cisco uBR10-MC5X20 line cards, to a bonding capable cable plant.
- EQAM is not required for the I-CMTS solution. Therefore I-CMTS solution is easier to maintain as there is one less piece of equipment than in the M-CMTS solution.

Wideband Cable Modem Functionality

The wideband cable modem is a standalone device capable of inter-operation with an industry standard DOCSIS 1.x, DOCSIS 2.0, or DOCSIS 3.0-compatible CMTS, and it also supports wideband operation when used with a wideband CMTS.

The wideband cable modem operates in either of these ways:

- As a DOCSIS 1.x or DOCSIS 2.0 cable modem, it receives all DS traffic as non-bonded traffic on its primary DS.
- As a wideband cable modem, it receives all DS traffic as bonded traffic—a wideband channel consisting of one or more RF DSs.

This section focuses on the role of the modem as a wideband cable modem. The explanations in this section are generic and apply to all wideband cable modems supported by the Cisco DOCSIS 3.0 DS Solution.

Wideband cable modem functionality may vary depending on the wideband cable modem vendor. For implementation information on vendor-specific wideband cable modems, see the “Wideband Cable Modem Behavior” section in [Chapter 6, “Implementing and Configuring the Solution.”](#)

Wideband Cable Modem Design and Operation

The wideband cable modem is backward-compatible with DOCSIS 2.0 and contains a complete DOCSIS 3.0 core. [Figure 5-6](#) shows a simplified block view of the wideband cable modem.

Figure 5-6 Wideband Cable Modem Block View

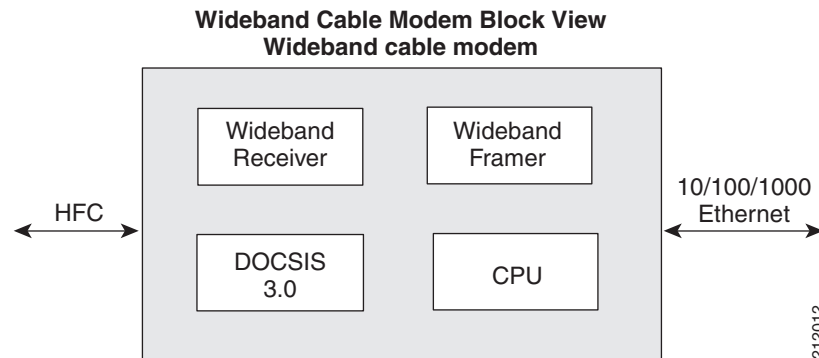

The wideband cable modem has a wideband receiver that receives the multiple RF channels of a bonded channel. It also has a wideband framer that decodes the signal from the wideband receiver and extracts the packets for the 10/100/1000-Mbps Ethernet home network.

The wideband cable modem identifies itself as being wideband-capable during the configuration process. This allows the DOCSIS Trivial File Transfer Protocol (TFTP) cable modem configuration provisioning server to enable or disable the wideband mode, and to choose the appropriate configuration parameters.

A wideband channel uses the same DOCSIS frame format as a DOCSIS channel uses. The channel just has more bandwidth. For DOCSIS 3.0 DS bonding, a new extended header for wideband has been added to the DOCSIS protocol. The extended header defines the logical wideband channel and a sequence number that the wideband cable modem uses for resequencing the wideband packets.

The CISCO-CABLE-WIDEBAND-MODEM-MIB for the wideband cable modem is supported and is an extension to the existing cable modem MIB.

Cisco DOCSIS 3.0 DS Solution

The Cisco DOCSIS 3.0 DS Solution utilizes either the DOCSIS M-CMTS architecture with the Cisco Wideband SPA and Cisco uBR-MC3GX60V cable interface line card, or the DOCSIS I-CMTS bonding with the Cisco UBR-MC20X20V and Cisco uBR-MC88V cable interface line cards. This enables cable operators to optimize their networks for additional bandwidth. The solution provides support for both narrowband and wideband modems, allowing both types of cable modems to share the same DS channels. The DOCSIS 3.0 DS Solution is backward compatible with DOCSIS 1.x and DOCSIS 2.0 services and networks.

The Cisco DOCSIS 3.0 DS Solution encompasses the following:

- [Primary-Capable Downstream Channels](#)
- [Extensible MAC Domain Support Through Channel Grouping Domain](#)
- [Virtual Bundle Support for Modular Cable Interfaces](#)
- [Fiber node](#)

- Enhanced M-CMTS Channel Support
- Load Balancing Support for DOCSIS 1.x or DOCSIS 2.0 Modems on SPA RF Channels
- Legacy Feature Support
- Primary-Capable Downstream Channel Selection
- High Availability Support for Cable Modems on SPA DS Channels

Figure 5-7 illustrates the Cisco DOCSIS 3.0 DS solution using the Cisco uBR-MC3GX60V cable interface line card.

Figure 5-7 Cisco DOCSIS 3.0 DS Solution Using Cisco uBR-MC3GX60V Cable Interface Line Card

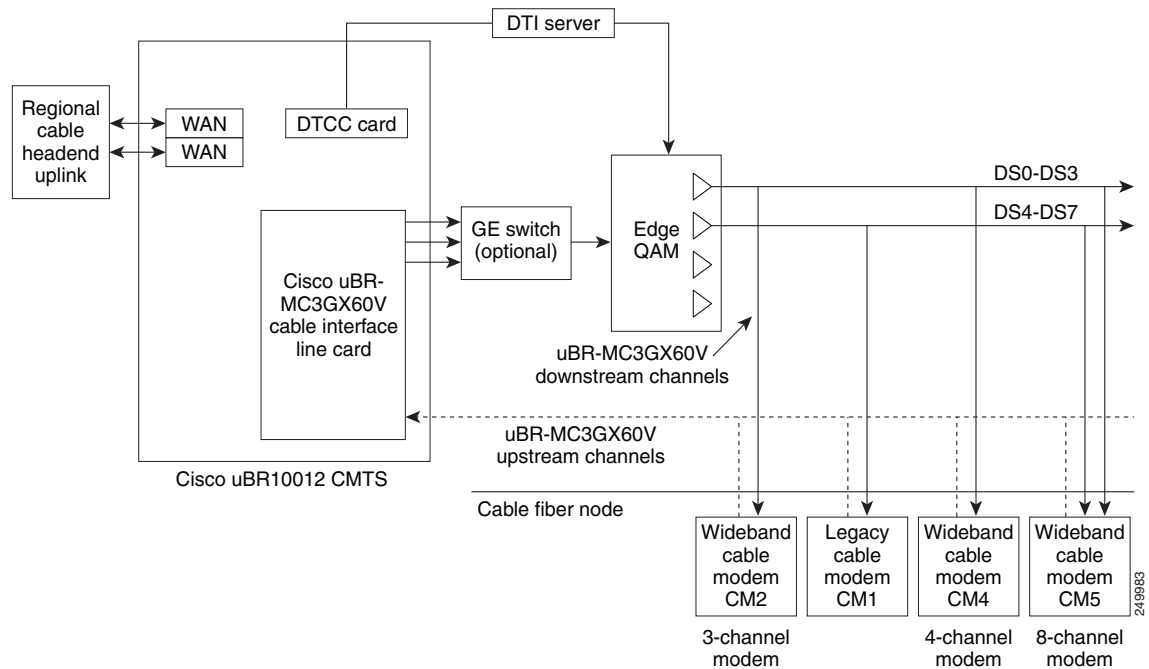

In Figure 5-7:

- Cable Modem 1 (CM1) represents a DOCSIS 1.x or DOCSIS 2.0 modem. This modem uses a DS channel on a Cisco uBR-MC3GX60V cable interface line card as its primary DS channel for both DOCSIS control messages as well as data traffic.
- Cable Modem 2 (CM2) represents a DOCSIS 3.0 modem with three tuners. This modem uses a Cisco uBR-MC3GX60V cable interface line card DS channel as its primary channel for DOCSIS control messages and a 3-DS bonded channel for its data traffic.
- Cable Modem 4 (CM4) represents a DOCSIS 3.0 modem with four tuners. This modem uses one DS channel as its primary channel, and a 4-DS bonded channel (including DS0-DS3 from the EQAM) for its data traffic.
- Cable Modem 5 (CM5) represents a DOCSIS 3.0 modem with eight tuners. This modem uses one DS channel as its primary channel, and an 8-DS bonded channel (including DS0-DS3 and DS4-DS7 from the EQAM) for its data traffic.

Figure 5-8 illustrates the Cisco DOCSIS 3.0 DS solution using the Cisco Wideband SIP/SPA and Cisco uBR10-MC5X20 cable interface line card.

Figure 5-8 Cisco DOCSIS 3.0 DS Solution Using the Wideband SIP/SPA and Cisco uBR10-MC5X20 Cable Interface Line Card.

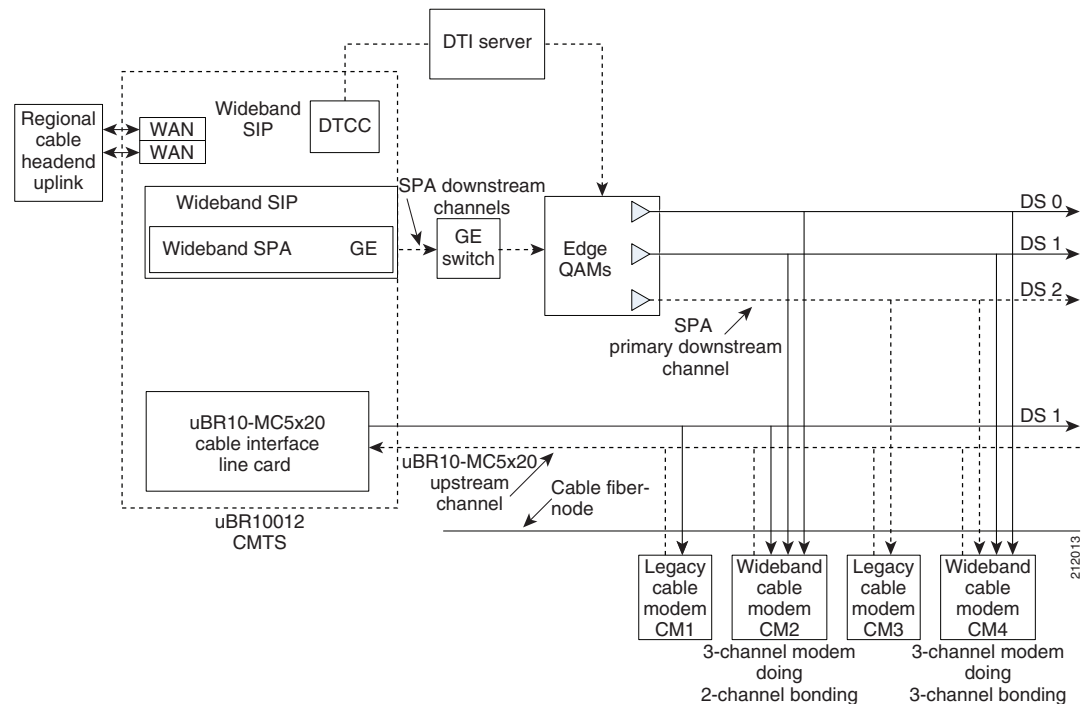

In Figure 5-8:

- Cable Modem 1 (CM1) represents a DOCSIS 1.x or DOCSIS 2.0 modem. This modem uses a DS channel on a Cisco uBR10-MC5X20 line card as its primary DS channel for both DOCSIS control messages as well as data traffic.
- Cable Modem 2 (CM2) represents a DOCSIS 3.0 modem with three tuners. This modem uses a Cisco uBR10-MC5X20 line card DS channel as its primary channel for DOCSIS control messages and a 2-DS bonded channel for its data traffic.
- Cable Modem 3 (CM3) represents a DOCSIS 1.x or DOCSIS 2.0 modem, but in contrast to CM1, this modem uses the SPA DS channel as its primary channel.
- Cable Modem 4 (CM4) represents a DOCSIS 3.0 modem with three tuners. This modem uses one SPA DS channel (DS2) as its primary channel, and a 3-DS bonded channel (including DS1/DS2/DS3 from the SPA) for its data traffic.

Primary-Capable Downstream Channels

The DS channels from the Cisco uBR-MC3GX60V cable interface line card, Cisco UBR-MC20X20V cable interface line card or Cisco Wideband SPA may serve as a primary-capable channel as defined in DOCSIS 3.0. When configured as a primary-capable channel, the DS channel carries the DOCSIS MAC management messages including time synchronization (SYNC), bandwidth allocation map (MAP), Upstream Channel Descriptors (UCD), and possibly the primary MAC Domain Descriptor (MDD) messages, along with the non-bonded data traffic.

A DS channel, whether primary-capable or not, can always be part of a bonded channel that carries bonded data traffic.

A DS channel is made primary-capable via Channel Grouping Domain (CGD) configuration. The MAP and UCD messages carried by this channel may contain the information of all or a subset of the US channels, as specified by CGD in the MAC domain. CGD provides the flexibility of grouping specific DS with specific USs in any MAC domain.

A DS channel may only be a primary-capable DS channel for a single MAC domain. However, the same DS channel may be part of one or more bonded channels (wideband interface) that serve multiple MAC domains.

Modular-Cable and Integrated-Cable Interfaces

Modular-cable (MC) and Integrated-cable (IC) interfaces are logical representations of the capability of the DS channels to carry non-bonded data traffic on a DS RF channel. MC interfaces are instantiated when a Cisco uBR-MC3GX60V cable interface line card or Wideband SPA is inserted, configuration mode is entered and a configuration is changed in the interface. Similarly, IC interfaces are instantiated when a Cisco UBR-MC20X20V or Cisco uBR-MC88V cable interface line card is inserted and configured. However, for an MC or IC interface to be operational, the underlying DS channel must be configured as a primary-capable channel via the CGD (see [Extensible MAC Domain Support Through Channel Grouping Domain, page 5-52](#)). If a DS channel is not primary-capable, then sending non-bonded traffic over this DS is not supported.

RF Channel Bandwidth Allocation

When a DS channel is used by both an MC interface (or IC interface) and Wideband interfaces (WB interface), or when it is used by more than one WB interface, its bandwidth is statically partitioned between both these interfaces. When the bandwidth of a DS channel is not allocated to the corresponding MC interface (or IC Interface), 100 percent of this bandwidth is available for all the WB interfaces. However, if any amount of bandwidth of an RF channel is used for its MC interface, then only 96 percent of the DS channel bandwidth is available for allocation, for both the MC interface and the WB interfaces that use this DS channel. The remaining 4 percent is reserved for DOCSIS MAPs and other MAC Management Messages, because this DS channel could be enabled as a primary-capable channel to carry such messages.

Enhanced Channel Bonding Support

Because of the ability to use the same DS channel as a primary-capable channel and as part of a wideband channel, a DOCSIS 3.0 cable modem may use the same tuner to receive the DOCSIS control traffic and the bonded traffic on that channel. This allows the cable modem to make full use of its tuner capability, allowing n channel bonding for an n -tuner modem, as long as the primary channel of the modem is also part of an n -channel bonding group visible to that modem.

Extensible MAC Domain Support Through Channel Grouping Domain

A CGD is a collection of primary-capable DS channels that are associated with a common set of US channels. A CGD is always specified within the context of a MAC domain to which all the DS and US channels belong. The DS channel local to the MAC domain on the Cisco uBR10-MC5X20 cable interface line card is always primary-capable, but a DS channel of a Cisco Wideband SPA, Cisco UBR-MC20X20V line card, Cisco uBR-MC88V line card, or Cisco uBR-MC3GX60V line card has to be made primary-capable by explicit CGD configuration. A CGD provides the additional flexibility of associating a subset of the US channels within a MAC domain to any of the primary-capable DS channels, including the local DS channels. When an US channel is associated with a DS channel, its

information is included in the MAP and UCD messages sent through that DS channel. By default, all USs of a MAC domain are associated with the DS channels unless otherwise specified in the CGD configuration.

Multiple CGD configurations may be included in the same MAC domain, allowing the flexibility of the MAC domain to include various primary-capable DS channels associated with common or different sets of US channels.

The CGD can be defined in a flexible manner to support a variety of DS-US combinations on a fiber node. Here are a few examples—2 DS x 1 US, 2 DS x 2 US, 3 DS x 1 US, 3 DS x 2 US, and 4 DS x 1 US. The association of USs to primary-capable DS can be controlled to ensure that MAPs for a given USs are sent on the right set of DS instead of being flooded to all DSs in the MAC domain using bandwidth on all DSs.

Figure 5-9 provides an example of how CGD can be used to group channels of a Cisco uBR-MC3GX60V MAC domain. The MAC domain consists of DS channels 0 through 3 of controller 0 and US channels 0 through 3.

Figure 5-9 Flexible US/DS Associations in Cisco uBR-MC3GX60V Line Card

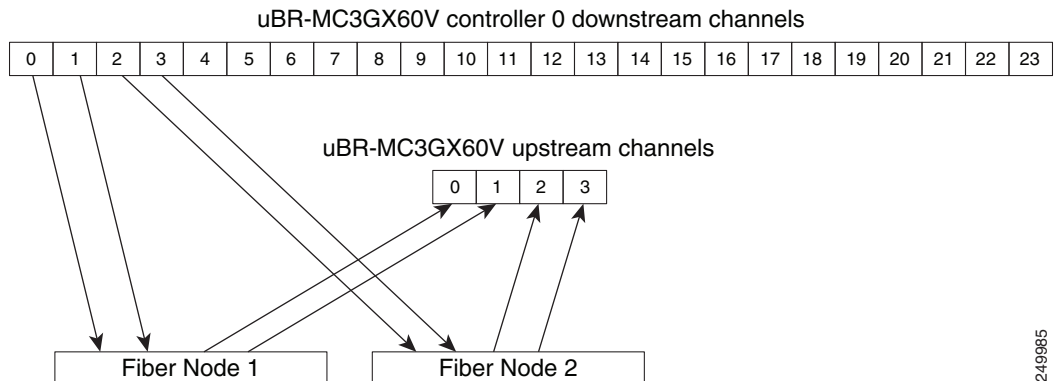

Figure 5-9 shows the fiber nodes served by the frequencies of the US and DS associations listed in Table 5-1

Table 5-1 US/DS Association to Fiber Nodes in the Cisco uBR-MC3GX60V Cable Interface Line Card

CGD1	Fibernode 1	US0, US1, DS0, DS1
CGD2	Fibernode 2	US2, US3, DS2, DS3

In this example, the four US channels and four DS channels are divided into two separate CGDs. Two CGDs are created to associate specific USs and DSs. By doing so, bandwidth on DS0 and DS1 is only required for MAPs and UCDs of US channels US0 and US1, but not US2 and US3. Similarly, bandwidth on DS2 and DS3 is only required for MAPs and UCDs of US channels US2 and US3, but not US0 and US1.

Figure 5-10 provides an example of how the flexible US and DS association may facilitate the distribution of channel frequencies to different fiber nodes. This illustration only represents the US and DS associations of primary-capable DS channels in the Cisco Wideband SPA along with the Cisco uBR10-MC5X20 line card.

Figure 5-10 Flexible US/DS Associations

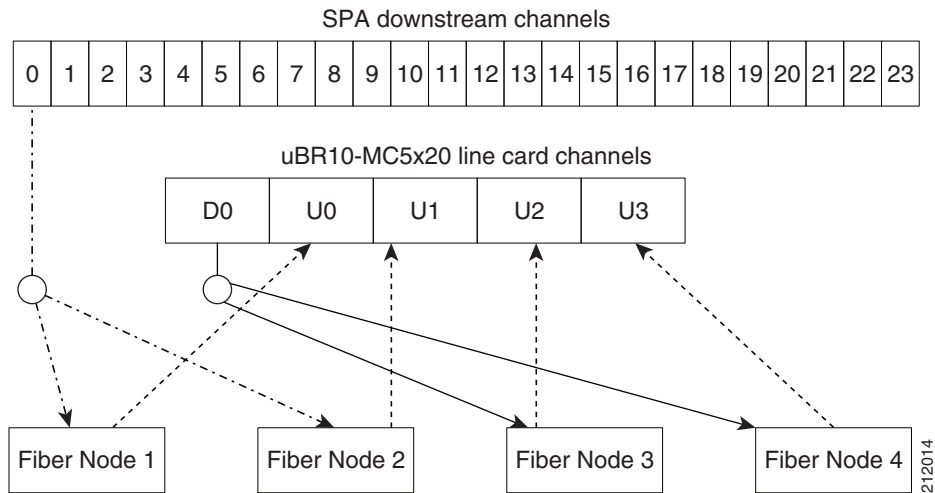

Figure 5-10 shows the fiber nodes served by the frequencies of the US and DS associations listed in Table 5-2.

Table 5-2 US/DS Association to Fiber Nodes in the Cisco Wideband SPA With the Cisco uBR10-MC5X20 Cable Interface Line Card

Fiber Node 1	US0 and SPA DS0
Fiber Node 2	US1 and SPA DS0
Fiber Node 3	US2 and uBR10-5x20 DS0
Fiber Node 4	US3 and uBR10-5x20 DS0

Therefore, in this example, SPA DS0 needs to be associated only with US0 and US1, and Cisco uBR10-MC5X20 DS0 needs to be associated only with US2 and US3.

Virtual Bundle Support for Modular Cable Interfaces

The Cisco CMTS does not allow explicit configuration of the virtual bundles on the MC or IC interfaces. When a CGD configuration within a MAC domain designates a DS channel as a primary-capable channel, the corresponding MC or IC interface is exclusively associated with the MAC domain and this MAC domain is referred to as the “hosting MAC domain” of the MC or IC interface. As a result, the MC interface automatically inherits the bundle membership of its hosting MAC domain, that is, if a Layer 3 virtual bundle includes a particular MAC domain as its member, it also includes all of the MC interfaces hosted by the same MAC domain.

CMTS Interfaces Associated With a Cable Modem

Prior to Cisco IOS release 12.3(23)BC, the Cisco uBR10-MC5X20 cable interfaces were used to manage both the US and DS traffic to cable modems, but with the introduction of the M-CMTS architecture, there is a need to separate this functionality. While the Cisco uBR10-MC5X20 line card DS interfaces are used to manage US traffic, the Cisco uBR10-MC5X20 line card interfaces, the SPA DS channel wideband

cable interfaces, and modular-cable interfaces can be used to manage DS traffic. Therefore, interfaces from the Cisco uBR10-MC5X20 line card, the SPA DS wideband and MC interfaces can be simultaneously involved in the communication with a cable modem.

Here are possible scenarios where interfaces from the Cisco uBR10-MC5X20 line card and the SPA DS can be involved in the communication with a cable modem:

- DOCSIS 1.x or DOCSIS 2.0 modem using a Cisco uBR10-MC5X20 DS channel as its primary channel.

The Cisco uBR10-MC5X20 cable interface is used for both US and DS traffic.

- DOCSIS 1.x or DOCSIS 2.0 modem using a primary-capable SPA DS channel as its primary channel.

The Cisco uBR10-MC5X20 cable interface, which is the hosting MAC domain of the modular-cable via CGD is used only for its US traffic, and the modular-cable interface is used for its DS traffic.

- DOCSIS 3.0 modem using a Cisco uBR10-MC5X20 DS channel as its primary channel.

The Cisco uBR10-MC5X20 cable interface is used for its US traffic and its DS DOCSIS MAC management messages. A wideband interface consisting of the SPA DS channels is used for its DS bonded data traffic.



Note The cable modem receive tuner tuned to the Cisco uBR10-MC5X20 DS channel cannot participate in channel bonding. Therefore a modem with n receive tuners can only achieve $n-1$ channel bonding.

- DOCSIS 3.0 modem using a primary-capable SPA DS channel as its primary channel.

The Cisco uBR10-MC5X20 interface, which is the hosting MAC domain of the MC interface via CGD, is used only for its US traffic. The primary-capable SPA DS channel is used for its DOCSIS MAC management messages, and a wideband interface is used for its DS bonded data traffic.

- If the primary-capable SPA DS channel is one of the bonding group channels, a modem with n receive tuners will be able to achieve n channel bonding.
- If the primary-capable SPA DS channel is not within the bonding group, a modem with n receive tuners will only be able to achieve $n-1$ channel bonding.

Starting with Cisco IOS Release 12.2(33)SCE, a DOCSIS 1.x, DOCSIS 2.0, or DOCSIS 3.0 cable modem may use Cisco uBR-MC3GX60V line card channels.



Note

Starting with Cisco IOS Release 12.2(33)SCG, it is possible to use Cisco uBR-MC3GX60V cable interface line card channels with Cisco Wideband SPA channels. However, it is not possible to share channels between two Cisco uBR-MC3GX60V cable interface line cards. A MAC domain must use DS and US channels from the local line card or Cisco Wideband SPA.

Fiber node

The fiber node configuration on the Cisco CMTS is used to construct the MAC domain service groups, or more specifically, the MAC domain DS service group (MD-DS-SG) as defined in DOCSIS 3.0. This information is used only by DOCSIS 3.0 modems. DOCSIS 1.x or DOCSIS 2.0 modems do not require fiber node configuration.

In HFC networks, all cable modems connected to the same coaxial segment of a fiber node reach the same set of DS and US channels on one or more CMTSs located at the headend.

A cable modem is physically connected to only one fiber node. On the CMTS, the fiber node software configuration defines the set of channels reaching the fiber node, and this configuration mirrors the physical topology of the cable network.

The fiber node must include at least one primary-capable channel for the modems connected to the fiber node to be operational. The fiber node can include one or more primary-capable channels from any of the following line cards:

- Cisco uBR10-MC5X20 line card, or from the primary-capable Cisco Wideband SPA DS channels, or both
- Cisco uBR-MC3GX60V line card, or from the primary-capable Cisco Wideband SPA DS channels, or both
- Cisco UBR-MC20X20V line card, or from the primary-capable Cisco Wideband SPA DS channels, or both
- Cisco uBR-MC88V line card

A fiber node configuration must be valid to be able to construct the MD-DS-SG. For a fiber node to be valid, it must satisfy the following conditions:

- Each DS channel within a fiber node must have been configured with a unique frequency.
- The DS channels within a fiber node must have unique DS channel IDs configured. In the Cisco IOS release 12.3(33)SCE, this can be achieved by enabling the Automatic Downstream Channel ID feature.
- All interfaces, which include the Cisco uBR10-MC5X20 cable interface, modular cable interface, and wideband interface, using any of the DS channels within a fiber node must be within the same virtual bundle.

Enhanced M-CMTS Channel Support

This section discusses the enhancements of the M-CMTS DS channels.

L2TPv3 Encapsulation Support on Downstream External PHY Interface

The Cisco DOCSIS 3.0 DS Solution supports DEPI data plane MPEG Transport Stream (D-MPT) within L2TPv3 encapsulation. The Cisco CMTS supports DEPI on both the Cisco uBR-MC3GX60V cable interface line card and Cisco Wideband SPA. The parameters required by L2TPv3 should be statically configured for each Cisco uBR-MC3GX60V cable interface line card and Cisco Wideband SPA DS channel, and must be consistent between the Cisco CMTS and EQAM.

SYNC Messages

A DEPI DS channel that is configured to be primary-capable requires SYNC insertion in the CMTS line card and SYNC restamping by the EQAM. Because this SYNC message handling is not standardized for legacy MPEG over User Datagram Protocol (UDP) format, configuring DEPI D-MPT/L2TPv3 transport for any SPA DS channel that is primary capable is required.

If a SPA DS channel is not used as a primary-capable channel, the legacy MPEG over UDP format is supported for backward compatibility.

DEPI Control Plane

In the Cisco IOS Release 12.2(33)SCE, the DEPI control plane functionality is supported. This includes DEPI protocol negotiation, DLM, session keepalive, and configuration synchronization between the CMTS and EQAM. For more information about the DEPI control plane, see the *M-CMTS DEPI Control Plane Guide* at the following URL:

http://www.cisco.com/en/US/docs/ios/cable/configuration/guide/m-cmts_depi_control_plane.html

Flexible Connection of DEPI Channels to EQAM Channels

Beginning in Cisco IOS Release 12.3(21)BC, the physical layer parameters including Annex, modulation, and interleave depth are configurable for each individual SPA DS channel. The same configuration applies to Cisco uBR-MC3GX60V channels in the Cisco IOS Release 12.2(33)SCE. This allows the DS channels in the same Cisco uBR-MC3GX60V line card and Cisco Wideband SPA to be tunneled via DEPI to an EQAM where RF channels from the EQAM are configured differently or to different EQAMs, thereby maximizing cable plant flexibility.

The following types of connectivity are supported between the SPA and the EQAM:

- Direct connection
- Connection through a Layer 2 Converged Interconnect Network (CIN)
- Connection through a single Layer 3 switch (for example, Cisco 7600 router)

Load Balancing Support for DOCSIS 1.x or DOCSIS 2.0 Modems on SPA RF Channels

Load balancing (LB) is the ability to assign a cable modem to a specific channel in order to utilize the DS and US bandwidth effectively. DS load balancing on SPA DS channels is restricted to DOCSIS 1.x and DOCSIS 2.0 modems. DS-only bonding-enabled modems are eligible for US load balancing without DS channel changes. The MC interfaces inherit DS load balancing group membership from the hosting MAC domain. If the US must be changed due to DS load balancing, the target US channel must be associated to the target DS channel in the CGD configuration, and belong to the same load balancing group as the current US channel of the modem with a lower load.

The load on an US or DS channel can be measured either by:

- The number of active cable modems, which includes wideband modems that use MC interfaces as primary DS channels
- Number of active service flows
- Channel bandwidth utilization

The balanced load can be accomplished by one of the following means:

- During initial ranging (preregistration), the system must determine that a modem should use another DS channel or US channel for balanced load, which is referred to as static load balancing.
- If a need arises, the system may also move online (registered) modems to other DS or US channels, which is referred to as Dynamic Load Balancing.

For Dynamic Load Balancing, Dynamic Channel Change (DCC) is used for changing the DS channel of the modem, Upstream Channel Change (UCC) is used for changing the US channel of the modem. Advanced DCC initialization techniques (DCC initialization technique 1 and above, which keeps modem online during the DCC transaction) can be used for channel changes among the DS channels within a CGD or between the CGDs if the CGD hosting interfaces reside on the same Cisco uBR10-MC5X20 line card. If DCC initialization technique 2 and above (which assumes the timing difference between the source and target channel pairs can be compensated by station maintenance ranging), is desired for channel change between a modular cable interface and a local Cisco uBR10-MC5X20 DS interface, the EQAM timing delay must be calibrated such that the DS PHY processing delay at EQAM is consistent with the DS PHY processing delay on a Cisco uBR10-MC5X20 line card.

For DS channel changes hosted by different Cisco uBR10-MC5X20 line cards, DCC initialization technique 0 will be enforced regardless of DCC initialization configuration in the load balancing group, in which case, the modem will drop offline on the source DS interface and reregister on the target DS interface.

**Note**

For Cisco uBR-MC3GX60V line card, the inter-line card LB groups are not supported, and the DOCSIS LB cannot steer CMs between the Cisco uBR-MC3GX60V line card and another line card. Other legacy and DOCSIS LB features function the same as other line cards.

Legacy Feature Support

The Cisco DOCSIS 3.0 DS Solution supports the following legacy features:

**Note**

For detailed information on legacy features, refer to the *Cisco uBR10012 Universal Broadband Router Software Configuration Guide*.

- Full DOCSIS Quality of Service (QoS)

The Cisco DOCSIS 3.0 DS Solution supports full DOCSIS QoS, including Committed Information Rate (CIR) support. DS low latency service flows for voice are configurable on all DS interface types.
- Bonded Multicast

Cisco DOCSIS 3.0 DS Solution supports bonded multicast for DOCSIS 3.0 compatible cable modems.
- DOCSIS Set-Top Gateway (DSG)

Cisco DOCSIS 3.0 DS Solution supports DSG on DOCSIS 1.x and DOCSIS 2.0 modems. DSG tunnel configuration is performed on the host interface and the modular cable interface inherits all DSG configurations of the host interface. The IP Media Gateway (IPMG) static group is enabled at the physical level of the modular cable interface. After the DSG configurations are added to the host interface, the DC Directories (DCD) are replicated on all modular cable interfaces that are part of the CGD.
- Subscriber Account Management Interface Specification (SAMIS)

Cisco DOCSIS 3.0 DS Solution supports SAMIS for service flows on Cisco uBR-MC3GX60V line card and SPA DS channels.
- Baseline Privacy Interface/Baseline Privacy Interface+

Cisco DOCSIS 3.0 DS Solution supports encryption of unicast packets for narrowband modems using Cisco uBR-MC3GX60V and Cisco Wideband SPA DS channels. For SPA deployment, the encryption keys are either generated or renewed in the Cisco uBR10-MC5X20 line card MAC domain and then forwarded to the SPA.

 - Static Multicast BPI

Cisco DOCSIS 3.0 DS Solution supports static multicast with BPI on modular-cable interfaces.
 - Dynamic Multicast BPI

Cisco DOCSIS 3.0 DS Solution supports dynamic multicast BPI. The encryption keys for dynamic multicast BPI are generated when an IGMP join is received from the CPE.
- Static Multicast QoS

Cisco DOCSIS 3.0 DS Solution supports static multicast QoS. For a Cisco uBR10-MC5X20 and Wideband SPA combination, the modular-cable interface inherits the QoS parameters from the Cisco uBR10-MC5X20 line card host interface and the cable bundle interface. Service flows are created when the multicast data is received. For modular-cable interfaces, the CMTS assigns unique service flow IDs ranging from 12K to 16K.

- Dynamic Multicast QoS

Cisco DOCSIS 3.0 DS Solution supports dynamic multicast QoS. The CMTS adds a service flow only to the DS interface of the cable modem where the IGMP join originated and the multicast data is only forwarded to that interface which has the service flow.

- Payload Header Suppression (PHS)

Cisco DOCSIS 3.0 DS Solution supports PHS for narrowband modems on all line cards.

- PacketCable MultiMedia (PCMM)

Cisco DOCSIS 3.0 DS Solution supports PCMM on wideband and is compliant with PCMM version IO3.

Primary-Capable Downstream Channel Selection

This section describes the primary-capable DS channel selection for wideband, narrowband, and voice-enabled modems.

Primary-Capable Downstream Channel Selection for Downstream Bonding Capable Cable Modems

In order to fully utilize DS bonding capacity, it is necessary to force DS bonding (wideband) capable modems to register on a primary-capable channel that is part of an operational DS bonding group.

A DS bonding capable modem is identified upon cable modem registration. A modem is DS bonding capable if the modem reports a multiple-tuner receive capacity and a Receive Channel Profile (RCP) known by the CMTS in a REG-REQ MP message. A wideband media terminal adapter (MTA) will be treated also as DS bonding-capable modems, therefore subject to the same primary channel selection policy.

In order to select a bonded primary channel (a primary channel that is part of a DS bonding group), the CMTS must know the DS service group information of the modem. If the modem has resolved its MD-DS-SG, the CMTS will select a primary channel that is part of an operational bonding group, which in turn is part of the QAM set corresponding to the MD-DS-SG determined by the modem. The bonded primary channel has to be hosted by an interface on the same Cisco uBR10-MC5X20 line card. A target DS channel will be selected randomly among channels that match the above criteria. If the modem has not resolved the MD-DS-SG, an enforce option is provided through the configuration to allow the CMTS to select a bonded primary channel based on the MAP group associated to the US channel of the modem. It is assumed that in many deployed topologies, an US channel is configured into a single fiber node, so that the CMTS can infer the topology information based on the DS channels associated to the US. If no target primary channel can be found, the modem will be allowed to register on its current primary channel.

The primary channel selection for bonding capable modems can be enabled through the global DS channel selection configuration. By default, if this configuration is not present, DS bonding capable modems will be allowed to operate on a primary channel even it is not included in any load balancing group.

At any time after the system is up, enabling the primary channel selection for bonding capable modems will not affect existing modems in the system. The bonding capable modems have to be manually reset using the **clear cable modem** command either globally or at the per-MAC domain level.

Primary-Capable Downstream Channel Selection for Narrowband Cable Modems

The primary DS channel selection for narrowband modems is intended to provide the operator the flexibility to segregate non-bonding capable modems to specific types of DS channels with the following two options:

- Redirecting modems that access a CMTS with legacy DOCSIS INIT-RNG-REQ at initialization
This option helps to prevent potential non-bonding capable modems. The modems initialize with legacy initial ranging request message type, INIT-RNG-REQ, by registering to a CMTS that is loaded with bonding capable modems. Although a DOCSIS 3.0 modem may also send INIT-RNG-REQ if it fails to receive the MAC Domain Descriptor (MDD) message, this option allows to filter out and redirect all potential pre-DOCSIS 3.0 non-bonding capable modems at the initial ranging time of the modem without waiting for modem registrations. The target frequency is specified using DS frequency in Hertz. If the target frequency matches one or multiple DS channels on the local CMTS, load balancing will be disabled on these DS channels to prevent modems being moved away from the target channel for load balancing purposes.
- Moving non-bonding capable modems to bonding-disabled primary channels
This option helps to restrict non-bonding capable modems to non-bonded primary channels on the CMTS. A more stringent method is applied for this option to identify the non-bonding capable modems, by decoding the Multiple Receive Channel Support capability (Type Length Value [TLV] 5.29) and RCP ID (TLV 48.1) of the modem in the registration request. A modem is non-bonding capable if it reports value 1 for TLV 5.29 or RCP IDs unknown to the CMTS. With this option, a non-bonding capable modem, identified at registration, will be moved to a non-bonded primary channel through DS frequency override, if its current primary channel is part of a bonding group. The target non-bonded primary channel will be selected among primary capable channels that are associated to the current US channel of the modem, however the non-bonded channel will not be included in any bonding groups associated to any host interfaces on the local line card. When this option is enabled, the bonded primary channels will be taken out of the load balancing group to prevent non-bonding capable modems from being moved back to bonded primary channels for load balancing purposes.

These two options can be enabled through the global DS channel selection configuration. By default, if the configuration is not present, the modem will be allowed to continue the ranging process on its current primary channel. At any time after the system is up, enabling DS channel selection to segregating non-bonding capable modems will not affect existing modems in the system. Additionally, if the frequency specified for the target DS channel is changed, the new frequency setting will only affect new modems trying to initialize after the frequency change. In order to enforce the DS selection policy on existing modems, the non-bonding capable modems must be manually reset using the **clear cable modem** command.

Downstream Channel Selection for Voice-Enabled Cable Modems

This DS channel selection option provides the ability to provide high-availability for voice services by restricting voice-enabled modems to Cisco uBR10-MC5X20 or Cisco UBR-MC20X20V DS channels. Because high-availability is not supported by the Wideband SPA, it is necessary to force voice-enabled modems to use primary channels of line cards that do support high-availability. This includes the Cisco uBR10-MC5X20, Cisco UBR-MC20X20V or Cisco uBR-MC3GX60V line cards.

A voice-enabled cable modem is identified either at registration by decoding the Dynamic Host Control Protocol (DHCP) TLV 122 in the DHCP-ACK of the modem, or at its first voice call if the DHCP TLV 122 is not exchanged. If a voice-enabled modem is detected at registration on a SPA DS channel, it will be moved to the Cisco uBR10-MC5X20 DS channel in the CGD via DS frequency override. If the voice-enabled modem is detected at its first voice call after registration, it will be moved after the call is over to the Cisco uBR10-MC5X20 DS channel in the CGD via DCC using DCC initialization technique

1. If the voice-enabled modem fails to come up on the target Cisco uBR10-MC5X20 DS channel, the CMTS will continue to move the modem until the maximum number of retries (3) has been reached. The modem will be allowed to stay on the SPA DS channel until another set of retries is attempted by the CMTS every 24 hours. A voice-enabled modem on the Cisco uBR10-MC5X20 DS channel will be excluded from being load balanced to a SPA DS channel.

The DS channel selection option to support high availability for voice-enabled modems can be enabled via global DS channel selection configuration. By default, if this configuration is not present, voice-enabled modems are allowed to operate on both the Cisco uBR10-MC5X20 DS channel and SPA DS channels in the CGD. If this option is enabled at any time after the system is up, voice-enabled modems that have been identified on the SPA DS channel without active voice calls will be gradually moved to the Cisco uBR10-MC5X20 or Cisco UBR-MC20X20V DS channel in the CGD at the rate of one modem per five seconds.

High Availability Support for Cable Modems on SPA DS Channels

Cisco High Availability enables network-wide resilience to increase IP network availability. This feature is supported for PRE redundancy, N+1 redundancy for the Cisco uBR10-MC5X20 line cards, and N+1 failover of the modular host line card. A Cisco Wideband SPA does not support high-availability operations by itself and uses a modular host line card for these high-availability operations. The higher system availability feature is implemented using the HCCP and the high availability infrastructure for the N+1 redundancy and PRE redundancy, allowing the cable modems to stay online in certain failure scenarios.

When a narrowband cable modem uses a SPA RF DS channel and a Cisco uBR10-MC5X20 MAC domain host, and if the Cisco uBR10-MC5X20 MAC domain host to which the SPA RF channel belongs fails, the modem stays online because of N+1 redundancy of the Cisco uBR10-MC5X20 line card. The same is true if the MAC domain host line card is a Cisco UBR-MC20X20V line card.

In a scenario where a wideband cable modem SPA uses a Cisco uBR10-MC5X20 cable interface line card as a modular host (which is different from the MAC domain of the modem, as defined by the CGD), if the modular host Cisco uBR10-MC5X20 cable interface line card fails, the modem stays w-online because of the N+1 redundancy support for the modular host on the Cisco uBR10-MC5X20 cable interface line card. Similarly, if the host MAC domain line card fails and has a protect card, wideband cable modems will stay w-online.

For more information about the modular host line card, refer to the **modular-host subslot** command in the *Cisco CMTS Cable Command Reference*.

[Table 5-3](#) summarizes the scenarios in which the modems are functional during specific component failures.

Table 5-3 High Availability for Cable Modems

Component Failure	Narrowband Cable Modems Using Cisco uBR10-MC5X20 Downstream Channels	Narrowband Cable Modems Using the SPA Downstream Channels	Wideband Cable Modems Using Cisco uBR10-MC5X20 Channels as Primary Downstream Channels	Wideband Cable Modems Using SPA Channels as Primary Downstream Channels
Cisco uBR10-MC5X20 MAC domain host	Online	Online	Online	Online
Cisco uBR10-MC5X20 modular host line card for the SPA	Not Applicable	Online	Online	Online
Cisco uBR10-MC5X20 MAC Domain host serving also as the uBR10-MC5X20 modular host line card for the SPA	Not Applicable	Online	Online	Online
PRE	Online	Online	Online	Online

**Note**

The Cisco UBR-MC20X20V line card provides equivalent functionality as the Cisco uBR10-MC5X20 line card specified in [Table 5-3](#).

**Note**

Beginning with Cisco IOS Release 12.2(33)SCE1, the N+1 redundancy feature including DEPI redundancy is supported on the Cisco uBR-MC3GX60V cable interface line card.

High Availability for Voice Modems

The Cisco DOCSIS 3.0 DS Solution provides higher system availability for voice services by providing the ability to restrict voice services only to Cisco uBR10-MC5X20 or Cisco UBR-MC20X20V line cards. This allows the CMTS to make an attempt to move the voice modems to a MAC domain host line card with DS channels in the same load balancing group.

DOCSIS 3.0 Wideband Channel Support

The Cisco DOCSIS 3.0 DS Solution is an industry-standard DOCSIS 3.0 implementation of channel bonding. The Cisco Wideband SPA, Cisco UBR-MC20X20V, Cisco uBR-MC88V, and Cisco uBR-MC3GX60V line cards are all bonding capable line cards. With channel bonding, the bandwidth is increased by combining or bonding multiple RF channels to create a wideband channel. The Cisco DOCSIS 3.0 DS Solution extensions affect the CMTS and the cable modem and the

provisioning and network management systems. For example, a 3-channel cable modem that performs 3-channel bonding must be able to access three RF channels of which at least one RF channel must be a primary-capable channel that is used for modem registration.

The core of the DOCSIS 3.0 DS Solution is the sending of DOCSIS packets for a given service flow across multiple RF channels, offering significant increases in the peak DS data rate that can be provided to a single cable modem. The transmit framer in the Cisco DS bonding line cards “strips” the DOCSIS packets for a given flow and transmits them across the multiple RF channels of the wideband channel. When the packets are received at the wideband cable modem, the receiver framer of the modem uses a sequence number embedded in each DOCSIS packet to reassemble the packets into the original flow.

The Cisco DOCSIS 3.0 DS Solution defines a *wideband channel* as a unique combination of DS RF channels from the same SPA or DOCSIS 3.0 cable interface line card. The wideband CMTS manages up to 32 wideband channels per Wideband SPA, 30 wideband channels per Cisco UBR-MC20X20V line card, 12 wideband channels per Cisco uBR-MC88V line card, and 96 wideband channels per Cisco uBR-MC3GX60V. A wideband cable modem can use one or more wideband channels. Many wideband cable modems can share the same wideband channel.

In the M-CMTS network architecture, the Cisco uBR-MC3GX60V or Wideband SPA on the Cisco uBR10012 router provides DOCSIS 3.0 channel bonding for DOCSIS network processing. In the Cisco DOCSIS 3.0 DS Solution, for the wideband DS channel, these two cards use one or more Gigabit Ethernet ports to send data traffic to the EQAM device. This EQAM device uses one or more QAM output channels, depending on how the wideband channel is configured, to send stripped packets to the wideband cable modem.

In Cisco DOCSIS 3.0 DS Solution, channel bonding is used only for DS wideband channels. A DS wideband channel can combine up to eight RF channels for a total bandwidth of up to 292 Mbps in the Annex B mode.

Channel bonding is used only for DS wideband channels with a:

- Cisco/Scientific Atlanta DPC3010, a DS wideband channel can combine up to eight RF channels for a total bandwidth of up to approximately 292 Mbps. This modem can also bond in the US direction on all four of its US channels.
- Cisco/Scientific Atlanta DPC3000, a DS wideband channel can combine up to four RF channels for a total bandwidth of up to approximately 146 Mbps. This modem can also bond in the US direction on all four of its US channels
- Linksys WCM300-NA modem, a DS wideband channel can combine up to eight RF channels for a total bandwidth of up to approximately 292 Mbps (at 6 MHz and 256 QAM).
- Scientific Atlanta DPC2505 modem, a DS wideband channel can combine up to three RF channels for a total bandwidth of over 100 Mbps (at 6 MHz and 256 QAM).

Figure 5-11 shows the a Cisco uBR-MC3GX60V line card having eight bonded channels on the EQAM device.

Figure 5-11 Cisco uBR10-MC3GX60V Channel Bonding to Create a Wideband Channel

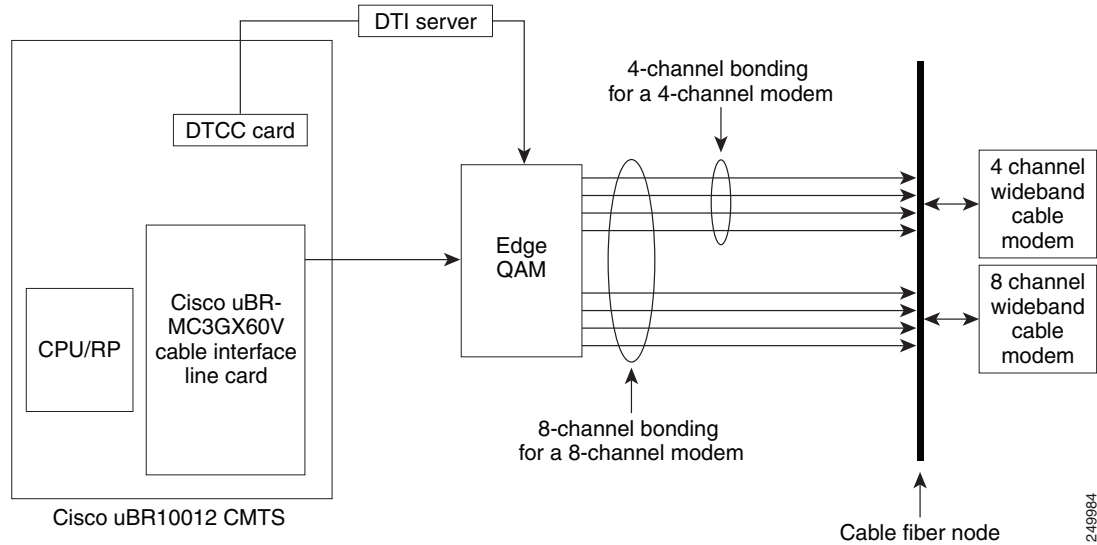
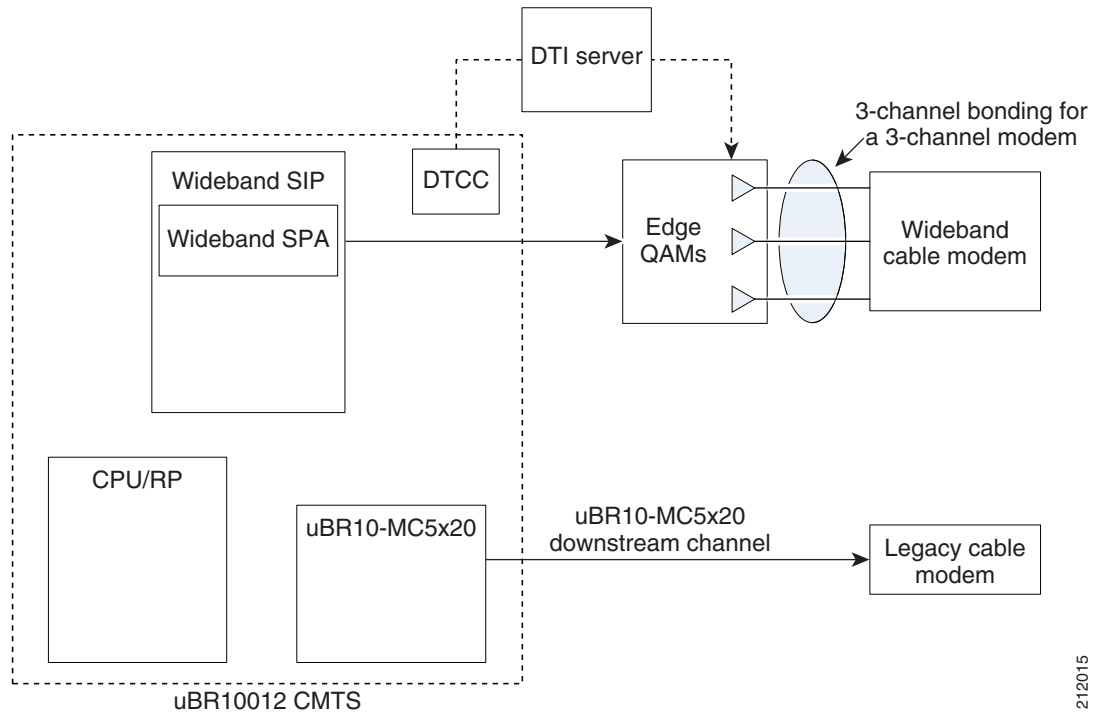

Figure 5-12 shows a wideband channel consisting of three bonded RF channels on the EQAM device. These RF channels are asynchronous and carry only bonded traffic.

Figure 5-12 Cisco uBR10-MC5X20 Channel Bonding to Create a Wideband Channel



For information on configuring wideband channels, see the *Cisco uBR10012 Universal Broadband Router SIP and SPA Software Configuration Guide*.

Security

A wideband channel uses Baseline Privacy Plus (BPI+) for its link level encryption. BPI+ provides cable modem users with data privacy across the cable network by encrypting traffic flows between the wideband cable modem and the wideband CMTS. BPI+ also provides MSOs with protection against theft of service.

The wideband cable modem uses the same BPI+ keys on its wideband channels as it does on its DOCSIS 1.x or DOCSIS 2.0 channels. The wideband cable modem uses the BPI+ keys negotiated on the primary service flow of the DOCSIS 1.x or DOCSIS 2.0 DS channel for the service flows on the wideband channel.

Quality of Service

For a modem that uses a wideband interface or MC interface as its DS data forwarding interface, its service flows will be associated with the Wideband or MC interface. The bandwidth for the WB or MC interfaces may vary due to configured bandwidth partitioning. The traditional support for cable QoS is otherwise unchanged.

Support for Cisco SIP-600 and Gigabit Ethernet SPAs

The Cisco 10000 Series SPA Interface Processor-600 (referred to as the Cisco SIP-600) is a high-performance, feature-rich SIP that functions as a carrier card for shared port adapters (SPAs) on the Cisco uBR10012 router. The SIP is compatible with the following platform-independent SPAs in Cisco IOS Release 12.2(33)SCB and later releases:

- Cisco Wideband SPA
- 5 port Gigabit Ethernet Shared Port Adapter
- 1 port 10-Gigabit Ethernet Shared Port Adapter (supported only with PRE4 configuration)

With a PRE2 configuration, the Cisco SIP-600 can support up to four Cisco Wideband SPAs, with a PRE4 configuration, the SIP can support up to six Cisco Wideband SPAs, and with a PRE5 configuration, the Cisco SIP-600 can support up to four Cisco 3 Gbps Wideband Shared Port Adapters and Cisco 6 Gbps Wideband Shared Port Adapters.

The Cisco SIP-600 is a full-height line card that occupies two physical slots in a Cisco uBR10012 router. Each chassis supports a maximum of two SIPs that can be inserted in the following slots:

- Slot 1
- Slot 3

The Cisco SIP-600 supports four bays (subslots) for the installation of SPAs. The SPA bays are numbered from 0 to 3 on a Cisco uBR10012 router. The number for each SPA bay is indicated by a small numeric label on the SIP faceplate.

SPAs on a Cisco uBR10012 router use an addressing format that specifies the physical location of the SIP, SPA, and interface in the format *slot/bay/port*, where:

- *slot*—Specifies the chassis slot number where the SIP is installed.

- *bay*—Specifies the secondary slot (subslot) of the SIP where the SPA is installed.
- *port*—Specifies the interface number that you want to select on the SPA.

For more information about the Cisco SIP-600 and supported SPAs, see the *Cisco uBR10012 Universal Broadband Router SIP and SPA Hardware Installation Guide* and *Cisco uBR10012 Universal Broadband Router SIP and SPA Software Configuration Guide*.

Wideband Modem Resiliency

Introduced in Cisco IOS Release 12.2(33)SCB, the Wideband Modem Resiliency feature enables the Cisco uBR10012 router to interact with DOCSIS 3.0-compliant cable modems in order to provide the best possible service in the event of non-primary RF channel disruptions such as loss of QAM, forward error correction (FEC) locks, and MDD time-outs. If a cable modem loses connectivity to the Cisco CMTS on one or all of its non-primary RF channels, the Cisco CMTS does not force the cable modem to perform a MAC reset and enables the cable modem to remain operational.

A DOCSIS 3.0-qualified CMTS transmits data to one or more DOCSIS 3.0-compliant cable modems using multiple RF channels. For a cable modem, one of the RF channels is used as the primary RF channel, and the rest of the channels are considered non-primary channels. The primary RF channel is defined as the DS RF channel where the cable modem receives DOCSIS MAC messages needed for US timing and synchronization.

This Wideband Modem Resiliency feature enables the CMTS to collect and analyze data related to RF channel disruptions per cable modem and identify the impairment. The MDD messages, sent on both primary capable and non-primary capable channels, informs the modem what status to report on a per-RF channel basis. The modem sends DOCSIS CM-STATUS messages in the US direction which the CMTS in turn analyzed for status indicating channel impairment. The CMTS is capable of determining if a subset of RF channels in a wideband channel are impaired, and temporarily dropping those channels out of the wideband channel for the modem to continue to receive bonded traffic. In this state, the modem is in wideband *partial* mode. When the impairment clears, the CMTS will automatically re-enable the RF channels.

For more information on how the Wideband Modem Resiliency feature enables the Cisco uBR10012 router to interact with DOCSIS 3.0-compliant cable modems, see the *Wideband Modem Resiliency* feature guide.

Dynamic Bandwidth Sharing

Dynamic bandwidth sharing (DBS) is the dynamic allocation of bandwidth for wideband (WB) and modular cable (MC) interfaces sharing the same DS channel. The bandwidth available to each WB, MC, or narrowband channel is not a fixed value—it depends on the configuration and the traffic load on the WB or MC.

DBS is achieved using a new type of modality called a link queue. Link queues represent a specific share of bandwidth on a particular channel. Link queues are used only to calculate the effective bandwidth of a channel, and such link queues are activated and deactivated according to the state of activity on a specific channel. DBS and static bandwidth allocations are configured at the WB or MC interface level. By default, bandwidth for a WB or MC channel is statically allocated. When DBS is enabled on an interface, the static bandwidth percentage is converted to a committed information rate (CIR) value for the corresponding link queue. The interface CIR value represents the guaranteed portion of the interface bandwidth and is used for admission control of the service flows with minimum reserved rate. When

DBS is enabled, you can also specify the remaining ratio value of the excess bandwidth for the link queue. If DBS is enabled and no bandwidth percentage is specified, no bandwidth is reserved for the WB or MC interface and the interface is effectively in protocol down state where link queues are not created.

DBS does not preclude static bandwidth configuration. If a static portion of bandwidth is configured on any RF channel that one or more DBS-enabled channel utilizes, that portion is subtracted from the CIR of the RF link. Therefore, such a portion is always reserved and is not available to dynamic WB or MC interfaces. The DBS feature continues working across line card and Performance Routing Engine (PRE) switchovers with no loss of functionality.

For more information on dynamic allocation of bandwidth for WB modems and MC interfaces, see the *Dynamic Bandwidth Sharing on the Cisco CMTS Router* feature guide.

DOCSIS WFQ Scheduler

The DOCSIS Weighted Fair Queuing (WFQ) Scheduler feature is an output packet scheduler that provides output scheduling services on both WAN uplink interfaces and DOCSIS DS interfaces.

In Cisco IOS Release 12.2(33)SCB, the DOCSIS WFQ scheduling engine is used to provide output packet scheduling services including absolute priority queueing, weighted fair queueing, minimum rate guarantee, shaping, and DOCSIS bonding group DBS on the Cisco uBR10012 router. It replaces the existing Versatile Traffic Management System (VTMS) scheduler.

For more details on the DOCSIS WFQ Scheduler, see the *DOCSIS WFQ Scheduler on the Cisco CMTS Routers* feature guide.

Voice Support on Wideband Modems

CMTS supports voice services on voice-enabled wideband (WB) cable modems. Committed information rate (CIR) DS service flows on WB interfaces are supported. You can reserve up to 90% of the wideband interface bandwidth. If multiple MAC domains (MDs) are sharing a WB interface, the available link rate is distributed evenly between all MDs that share the WB interface. If the MDs that share the WB interface are on the same line card, they share the CIR pool.

To display the reserved and available bandwidth, you can use the **show hw-module bay all association wideband** command for the Wideband SPA, or the **show controllers** command with the **association** keyword for the DOCSIS3.0 cable interface line cards. To display the reserved and available bandwidth for wideband interfaces, you can use the **show interface wideband-cable** command. For more information on these commands, see the *Cisco IOS CMTS Cable Command Reference Guide*.



Note

In the Cisco IOS Release 12.2(33)SCB, new commands have not been introduced for this feature. However, you must first enable PacketCable or multimedia PacketCable to enable the voice support feature.

DOCSIS 3.0 Downstream Bonding for Bronze Certification

The DOCSIS 3.0 DS Bonding for Bronze Certification feature enables high-speed broadband access (100 Mbps) and helps offer more bandwidth-intensive services by adding one or more additional DS QAM channels to the standard broadband DOCSIS system. This new set of DS channels is grouped into a larger channel, known as a bonded channel.

For more information on the DOCSIS 3.0 DS Bonding for Bronze Certification, see the *DOCSIS 3.0 Downstream Bonding for Bronze Certification* feature guide.



Implementing and Configuring the Solution

This chapter provides implementation and configuration information for the Cisco DOCSIS 3.0 Downstream Solution, for Cisco IOS Release 12.3(23)BC and Cisco IOS Release 12.2(33)SCB (and later releases), and contains the following topics:

- [Wideband CMTS Configuration, page 6-69](#)
- [Wideband Cable Modem Behavior, page 6-77](#)
- [Cisco SIP-600 and Gigabit Ethernet SPA Configuration, page 6-82](#)
- [Supported MIBs, page 6-82](#)
- [Known Restrictions, page 6-84](#)

Wideband CMTS Configuration

This section provides an overview of the wideband CMTS configuration tasks:

- [Configuring Base CMTS Components, page 6-69](#)
- [Configuring Wideband CMTS Components, page 6-71](#)

This section also lists documents where you can find the detailed information needed to configure the Cisco IOS Software for the Cisco uBR10012 router components, including the components needed for the Cisco DOCSIS 3.0 Downstream Solution.

Configuring Base CMTS Components

The base CMTS is the Cisco uBR10012 router with the components needed for DOCSIS 1.x, DOCSIS 2.0 and DOCSIS 3.0 operations. Wideband cable components can be added to the Cisco uBR10012 base system so that it can be used as a wideband CMTS. For wideband cable operation, the configuration tasks for the base CMTS components are similar to the configuration tasks used for DOCSIS 1.x, DOCSIS 2.0 and DOCSIS 3.0 operations. The base CMTS can be used as a DOCSIS 1.x, DOCSIS 2.0 and DOCSIS 3.0 CMTS.

All wideband channels used on a fiber node and all associated primary downstream channels on Cisco uBR10-MC5X20 cable interface line cards must be configured to belong to the same virtual bundle interface. For detailed information on this configuration task, see the “Configuring a Virtual Bundle” section in the *Cisco uBR10012 Universal Broadband Router SIP and SPA Software Configuration Guide*.

Table 6-1 provides a list of the software configuration documents that are likely to be useful for configuring the Cisco DOCSIS 3.0 Downstream Solution, base CMTS components.

Table 6-1 Base CMTS Components Configuration—Where to Find Information

Solution Component	Where to Find Information
Cisco uBR10012 router (general and feature-specific configuration)	<p>Release Notes for Cisco uBR10012 Universal Broadband Router for Cisco IOS Release 12.3 BC (which includes information on Cisco IOS Release 12.3(21)BC)</p> <p>Cisco uBR10012 Universal Broadband Router Software Configuration Guide</p> <p>Cisco Cable Modem Termination System Feature Guide</p>
PRE2, PRE4, and PRE5	<p>Route Processor Redundancy Plus for the Cisco uBR10012 Universal Broadband Router</p> <p>Cisco uBR10012 Universal Broadband Router Performance Routing Engine Module</p> <p>Cisco Performance Routing Engine 5 Hardware Installation Guide</p>
Cisco uBR10-MC5X20, Cisco UBR-MC20X20V, and Cisco uBR-MC3GX60V line cards	<p>Configuring the Cisco uBR10-MC5X20U/H Broadband Processing Engine</p> <p>Configuring the Cisco UBR-MC20X20V Cable Interface Line Card</p> <p>Configuring the Cisco uBR-MC3GX60V Cable Interface Line Card</p> <p>Chapter 3, “Configuring Cable Interface Features for the Cisco uBR10012 Router,” in the Cisco uBR10012 Universal Broadband Router Software Configuration Guide</p> <p>“Cable Interface Bundling and Virtual Interface Bundling for the Cisco CMTS” in the Cisco Cable Modem Termination System Feature Guide</p> <p>“N+1 Redundancy for the Cisco Cable Modem Termination System” in the Cisco Cable Modem Termination System Feature Guide</p>
Gigabit Ethernet SPA	<p>Cisco uBR10012 Universal Broadband Router SIP and SPA Hardware Installation Guide</p> <p>Cisco uBR10012 Universal Broadband Router SIP and SPA Software Configuration Guide</p>
Half-Height Gigabit Ethernet (HHGE) network uplink line cards	<p>Configuring the Half-Height Gigabit Ethernet Line Card for the Cisco uBR10012 Universal Broadband Router</p>

The technical documentation set for the Cisco uBR10012 router includes many documents not shown in Table 6-1 that are useful for configuring the CMTS. The Cisco uBR10012 documentation set can be accessed from this URL:

http://www.cisco.com/en/US/products/hw/cable/ps2209/tsd_products_support_series_home.html

Configuring Wideband CMTS Components

The wideband CMTS components are added to the base CMTS components to make the CMTS wideband-capable. This section provides overview information on configuring the wideband CMTS components, which includes the components that are based on the integrated downstream RF channels, and the components based on the M-CMTS architecture.

- [Configuring a Wideband Capable Line Card, page 6-71](#)—This section is applicable to both DOCSIS 3.0 M-CMTS and DOCSIS3.0 I-CMTS downstream solution architecture.
- [Configuring M-CMTS Components, page 6-73](#)—This section is applicable only to DOCSIS 3.0 M-CMTS downstream solution architecture.

Configuring a Wideband Capable Line Card

All Cisco wideband capable line cards follow a uniform procedure for enabling wideband services. The following sections describe the procedure to configure wideband services on the Wideband SPA, Cisco uBR-MC3GX60V, Cisco uBR-MC20X20 and Cisco uBR-MC8X8V cable interface line cards:

- [Pre-Provisioning Configuration with the Card Command, page 6-71](#)
- [Configuring Controllers, page 6-71](#)
- [Configuring Primary-Capable Channel, page 6-72](#)
- [Configuring Modular-Cable or Integrated-Cable Interfaces, page 6-72](#)
- [Configuring Wideband Interfaces, page 6-72](#)
- [Configuring Fiber Nodes, page 6-73](#)

Pre-Provisioning Configuration with the Card Command

The line card can be preprovisioned with the **card** command, without the line card being present in the chassis. This allows you to configure your network topology for wideband deployment without the having the line card present. The configuration is applied to the line card when the online insertion and removal (OIR) of the card is performed.

**Note**

The **card** command is not applicable to the Cisco uBR-MC8X8 cable interface line card. This line card exists on the Cisco uBR7200 router series platform, which does not support the **card** command.

For more information on the **card** command, see the *Cisco IOS CMTS Cable Command Reference* at the following URL:

http://www.cisco.com/en/US/docs/ios/cable/command/reference/cbl_book.html

Configuring Controllers

All Cisco wideband-capable line cards have a configuration for channel parameters grouped into one or more controllers:

- Each wideband SPA has 1 controller with 24 channels.
- Each Cisco UBR-MC20X20V card has 5 controllers with 4 channels each.
- Each Cisco uBR-MC8X8 card has 2 controllers with 4 channels each.
- Each Cisco uBR-MC3GX60V card has 3 controllers with 24 channels each.

The following channel attributes are specified by the controller configuration:

- Frequency
- Annex—Annex A or Annex B
- Modulation—64 QAM or 256 QAM
- Interleaver

For the M-CMTS compliant line cards, apart from the channel attributes specified above, the DEPI channel attributes are also specified in the controller configuration.

For more information on the controller configuration, see the specific cable interface line card configuration guide.

Configuring Primary-Capable Channel

The set of primary-capable channels must be identified and configured with the CGD configuration line (or lines), in the related MAC domains. This step must be performed irrespective of whether the wideband services are deployed or not, and the cable plant supports only DOCSIS2.0 cable modems. The configuration is applied within the context of the individual MAC domains supported on each line card. Table 6-2 lists the supported number of MAC domains for each cable interface line card.

Table 6-2 Supported Number of MAC Domains for cable interface line

Cable Interface Line Card	Number of Supported MAC Domains
Cisco uBR-MC8X8	2
Cisco UBR-MC20X20V	5
Cisco uBR-MC3GX60V	15

cards

The **interface cable** and **downstream** commands are used to configure the primary-capable channel. This configuration binds a particular downstream RF channels to the MAC domain and optionally binds specific upstream channels in the MAC domain to specific downstream RF channels. The downstream channel are primary-capable, providing DOCSIS SYNC, MAP, and UCD signaling. For more information on primary-capable downstream channels, see section “[Primary-Capable Downstream Channels](#)” section on page 5-51

For more information on the CGD command, see the *Cisco Command Reference Guide* at the following URL:

http://www.cisco.com/en/US/docs/ios/cable/command/reference/cbl_book.html

Configuring Modular-Cable or Integrated-Cable Interfaces

Modular-cable interfaces and Integrated-cable interfaces must be configured to use at least 1 percent bandwidth of their underlying channel, to become protocol up and functional for use by the MAC domain. The interface will inherit the bundle ID from the parent MAC domain interface.

Configuring Wideband Interfaces

Wideband interfaces are configured to match the types of modems used in the cable plant in terms of the number of receive RF channels on those modems.

To utilize all the three channels, a Scientific Atlanta DPC2505 cable modem requires 3-channel wideband interfaces. Similarly, a 4-channel Scientific Atlanta DPC3000 cable modem requires 4-channel wideband interfaces, and a Scientific Atlanta DPC3010 cable modem requires 8-channel wideband interfaces. However, an N-channel cable modem may generally use a wideband interface smaller than N if that is a plant requirement. For example, a Scientific Atlanta DPC3010 cable modem can utilize a 4-channel wideband interface, but its maximum downstream bandwidth is then limited to four channels, not eight.

Wideband interfaces can be configured to overlap the RF channels in order to maximize DS channel usage. For example, a fiber node may support a cable plant with three, four, and eight channel wideband modems. A specific RF channel, say RF channel 0, may be included in all three wideband interfaces. The Cisco CMTS spreads the load on the overlapped channels in the wideband interfaces depending on the per RF channel load.

Configuring Fiber Nodes

The Cisco CMTS fiber node configuration provides the CMTS with topology information needed to generate the correct DOCSIS signaling and is mandatory for wideband operation. More specifically, a cable plant may have hundreds or thousands of fiber nodes serviced by multiple CMTSs. A specific Cisco CMTS may service up to 255 fiber nodes at one time. A specific fiber node is assigned to a geographic area, and the downstream channels (in CMTS controllers) and the upstream connector used on that fiber node are configured for service. The CMTS then generates the correct DOCSIS service group signaling in the MDD messages, for the cable modems to understand which channels are available for use. The cable modem in turn uses the MDD message content to pick a MAC domain service group as part of the modem registration.

For information on the preceding configuration tasks and for reference information on the Cisco IOS commands, see the following configuration guides:

- Wideband SIP, SIP-600, and Wideband SPA configuration, see the [Cisco uBR10012 Universal Broadband Router SIP and SPA Software Configuration Guide](#).
- For Cisco UBR-MC20X20V configuration, see the [Configuring the Cisco UBR-MC20X20V Cable Interface Line Card Guide](#)
- For Cisco uBR-MC8X8 configuration, see the [Configuring the Cisco uBR-MC88V Cable Interface Line Card](#)
- For Cisco uBR-MC3GX60V configuration, see the [Configuring the Cisco uBR-MC3GX60V Cable Interface Line Card](#)

Configuring M-CMTS Components

[Figure 5-1 on page 5-42](#) specifies the wideband components required in the M-CMTS deployments when the Cisco uBR-MC3GX60V line card is used. This section provides overview information on how to configure these wideband components in M-CMTS deployments:

- [Configuring the DOCSIS Timing and Control Card, page 6-74](#)
- [Configuring the Edge QAM Device, page 6-74](#)
- [Configuring the Gigabit Ethernet Switch, page 6-76](#)
- [Configuring the DTI Server, page 6-76](#)

Configuring the DOCSIS Timing and Control Card

The DOCSIS Timing and Control Card (DTCC), which acts as the DTI client, provides the interface to the DTI server for the Cisco CMTS. By default, the DTCC runs in a standalone mode and does not synchronize its timing to the external DTI server. The DTCC must be configured to operate as a DTI client. For information on configuring the DTCC to operate as a DTI Client, see the *Cisco uBR10012 Universal Broadband Router DTCC* documentation.

Configuring the Edge QAM Device

Edge QAM (EQAM) device configuration is device-specific and implementation-specific. The Cisco CMTS DOCSIS 3.0 Wideband Solution is compatible with the Cisco RF Gateway 1, Cisco RF Gateway 10 and Harmonic NSG 9000. For more information on how to configure EQAM, see the specific device documentation.

Regardless of the EQAM device or implementation, these items are used for Wideband configuration and must be configured on each EQAM device:

- For the edge QAM device:
 - IP address of the EQAM device Gigabit Ethernet interface (input port)
 - MAC address of the EQAM device Gigabit Ethernet interface (input port)
 - DEPI remote ID of the QAM output
- For each of the EQAM device QAM outputs that will be used for a DS channel:
 - Center frequency of the QAM output
 - Annex type, Annex A or Annex B
 - Modulation—64 QAM or 256 QAM
 - Interleaver—Interleaver settings can enhance downstream error correction capabilities

The IP address, MAC address, frequency, and DEPI ID configured on the edge QAM device are specified when configuring RF channels on the CMTS. Be certain to verify that the RF channel values set with the **rf-channel** (issued on the CMTS) command match the values configured on the edge QAM device.

**Note**

If a Layer 2 Gigabit Ethernet switch is used to connect the Wideband SPA to the EQAM device, the MAC address specified in the **rf-channel** command is the MAC address of the Gigabit Ethernet interface of the switch.

**Note**

The EQAM device may also require configuration to connect to a DTI server. For information on configuring the EQAM device, refer to the vendor EQAM device documentation.

For the Cisco IOS Release 12.2(33)SCE, the Cisco CMTS and Cisco RFGW 10 EQAM support a feature called Control Plane DEPI, which intelligently links the devices with two-way communication for the DEPI protocol. The protocol running on the Cisco CMTS side is capable of detecting EQAM control plane failure and activating redundancy functionality if configured. Moreover, the EQAM can be placed in learn mode, which allows it to learn the per-QAM configuration from the Cisco CMTS. This greatly decreases the chance of a misconfiguration between the Cisco CMTS and EQAM which might cause plant failure.

For information on the control plane DEPI feature, see the *M-CMTS DEPI Control Plane Guide* at the following URL:

http://www.cisco.com/en/US/docs/ios/cable/configuration/guide/m-cmts_depi_control_plane_ps2209_TSD_Products_Configuration_Guide_Chapter.html

An RF channel and EQAM configuration worksheet such as the one shown in [Table 6-3](#) may be useful for coordinating Wideband RF channel and EQAM device configuration. A wideband controller for M-CMTS line cards supports either 18 or 24 RF channels depending on channels that are configured for Annex A or B. For more information, see the description of the **rf-channel** command in *Configuring the Cisco uBR-MC3GX60V Cable Interface Line Card* or *Cisco uBR10012 Universal Broadband Router SIP and SPA Software Configuration Guide*.

Table 6-3 RF Channel and EQAM Configuration Worksheet

Wideband RF Channel	EQAM Device		QAM Output			DEPI Remote ID
	GE Input IP Address	GE Input MAC Address	QAM Module	Frequency	Annex type	
0						
1						
2						
3						
4						
5						
6						
7						
8						
9						
10						
11						
12						
13						
14						
15						
16						
17						
18						
19						
20						
21						
22						
23						

Configuring the Gigabit Ethernet Switch

A Gigabit Ethernet (GE) switch linking the Cisco Wideband line card and the edge QAM (EQAM) devices is optional but may enhance the wideband deployment in one or more of the following situations:

- When more than two EQAM devices are required for two or more Wideband controllers
- When VoD traffic and RF channels for wideband channels are mixed on the same EQAM device.
- When N+1 line card redundancy or line card port redundancy is configured. All the redundant ports may be connected to a switch which in turn is connected to the EQAM



Note

Beginning with Cisco IOS Release 12.2(33)SCE1, the N+1 redundancy feature including DEPI redundancy is supported on the Cisco uBR-MC3GX60V cable interface line card. For more information on redundancy schemes and configurations, see *Configuring the Cisco uBR-MC3GX60V Cable Interface Line Card Guide*.

The configuration of the Gigabit Ethernet switch is device-specific and implementation-specific, but it is recommended that virtual LANs (VLANs) be used to create separate broadcast domains for the traffic of each wideband controller.

Figure 6-1 shows an example of VLAN usage in a Wideband SPA deployment. Wideband SPA 1 uses the QAM outputs on EQAM A and EQAM B. Wideband SPA 2 uses the QAM outputs on EQAM C.

- VLAN 1 carries traffic for Wideband SPA 1.
- VLAN 2 carries traffic for Wideband SPA 2.

Both the Wideband SPAs and EQAM devices have redundant Gigabit Ethernet links that are members of the appropriate VLANs.

Figure 6-1 VLANs for Wideband Traffic

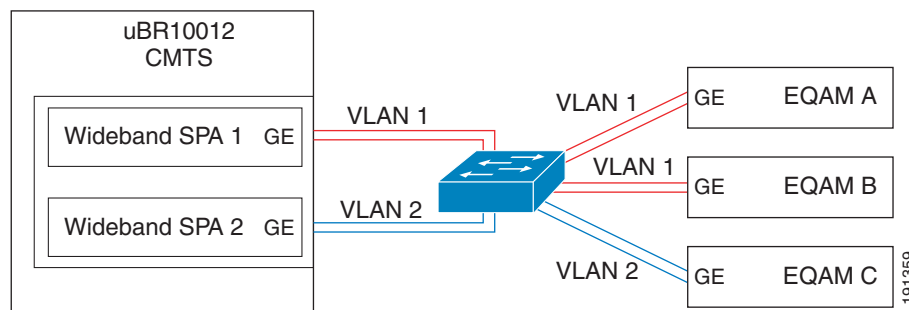

Configuring the DTI Server

The DTI server provides the DOCSIS time stamp and frequency to the DTI clients. The DTI server mode and Time Of Day (ToD) services are configurable. The ToD services can be configured to be the internal Real Time Clock (RTC) or it can be updated from the Global Positioning System (GPS). For information on configuring the DTI server, see the vendor DTI server device documentation.

Use the **cable clock dti** command to configure the Cisco CMTS to be used along with a DTI server.

Wideband Cable Modem Behavior

This section provides information on the wideband cable modems and their interactions with the CMTS. The following topics are discussed:

- [Cisco DPC3010, page 6-77](#)
- [Cisco DPC3000, page 6-77](#)
- [Linksys WCM300-NA, WCM300-EURO, and WCM300-JP Modems, page 6-77,](#)
- [Scientific Atlanta DPC2505 and EPC2505 Wideband Cable Modems, page 6-80](#)
- [CMTS Interactions with Wideband Modems, page 6-80](#)

Cisco DPC3010

The DPC3010 wideband modem is DOCSIS 3.0-compliant and is capable of bonding eight downstream channels and four upstream channels. The modem contains two tuners with four channels each. Each tuner has a frequency window of 32 MHz, therefore the channels received by each tuner must be consecutive. If the fifth channel's frequency is not immediately after the fourth channel's frequency, then a CMTS RCC template must be configured. For more information on RCC Template configuration, see *Cisco IOS CMTS Cable Software Configuration Guide, Release 12.2SC* Guide at the following URL:

http://www.cisco.com/en/US/docs/ios/cable/configuration/guide/VDOC_dbc_feature_support_TSD_Island_of_Content_Chapter.html

Cisco DPC3000

The DPC3000 wideband modem is DOCSIS 3.0-compliant on its four downstream channels. It has one upstream channel. The tuner has a frequency window of 82 MHz, therefore the four channels do not need to be consecutive.

Linksys WCM300-NA, WCM300-EURO, and WCM300-JP Modems

With the Linksys WCM300-NA, WCM300-EURO, and WCM300-JP wideband cable modems, the Cisco DOCSIS 3.0 Downstream Solution supports downstream data service to the cable modem on multiple bonded downstream channels. The Linksys WCM300 wideband cable modem supports the receiving of up to three wideband downstream channels:

- One primary-bonded channel
- Up to two secondary bonded channels

The primary-bonded channel is the wideband channel where the wideband cable modem receives all of its unicast traffic and some multicast traffic. The cable modem may identify the primary-bonded channel and any secondary-bonded channels to the CMTS at cable modem registration time. The DOCSIS configuration file may define the primary-bonded channel for the CMTS to assign to the cable modem.

Secondary-bonded channels are the wideband channels where the wideband cable modem receives additional multicast data streams. The DOCSIS configuration file defines the secondary-bonded channels for the modem to pass to the CMTS. Secondary-bonded channels are intended to receive multicast traffic such as broadcast video that is not available on the primary-bonded channel.

When the wideband cable modem registers with one primary and one or more secondary wideband channels, it accepts multicast packets from all associated wideband channels. The CMTS ensures that a multicast packet is not forwarded on the primary and secondary wideband channels simultaneously.

A primary-bonded channel cannot also be configured as a secondary-bonded channel, and vice versa. Secondary-bonded channels can be configured on the CMTS with the **cable bonding-group-secondary** command and with the DOCSIS configuration file using TLVs (primary bonding group ID and secondary-bonding group ID).

The Linksys WCM300 wideband cable modem implements a subset of the DOCSIS 3.0 protocol for channel bonding. Channel bonding is accomplished by the use of a per-packet sequence number to enable the wideband cable modem to deliver, in order, the packets from multiple RF channels that are destined to the CPE device. The Linksys WCM300 modem supports up to 16 independent resequencing engines for the receiving of bonded unicast traffic and bonded multicast traffic over its three bonded channels.

DOCSIS Configuration File for Wideband on Linksys WCM300 Modems

The Linksys WCM300 wideband cable modem obtains a DOCSIS configuration file as it does in DOCSIS 3.0. For wideband operation, the file may contain three wideband-related TLV encodings:

- Primary bonding group ID
- Bonded channel enable
- Secondary bonding group ID



Note The preceding TLVs can be optionally specified in the DOCSIS configuration file. These TLVs *are not required* for the Linksys WCM300 modem to operate in wideband mode (w-online).

All three TLVs are encoded as vendor-specific options (type 43) to facilitate interoperability and reduce future compatibility issues.

Primary Bonding Group ID

The primary bonding group ID option is encoded as subtype 14:

- Type.Subtype—43.14
- Length—2
- Value—primary bonding group ID

The primary bonding group ID option allows the provisioning system to force the wideband cable modem to use a particular primary bonded downstream channel. The modem can use a single primary bonded channel for unicast and multicast traffic. When the primary bonding group ID value is present, the CMTS assigns the wideband cable modem to the wideband-channel interface identified by the configured bonding group ID. If the CMTS is unable to assign the wideband cable modem to the wideband-channel interface specified by the configured bonding group ID, the CMTS causes the wideband cable modem to fail registration.

Only a single occurrence of the primary bonding channel ID option may be specified in the DOCSIS configuration file. The total of the RF channels in the primary and secondary bonded channels must comply with the 50-MHz capture-window limitation of the Linksys WCM300 modem.

**Note**

Cisco IOS Release 12.2(33)SCE onwards, the wideband interface bonding group IDs on the CMTS are no longer configurable. The IDs are created by the CMTS and assigned at bootup. The **show controller <modular-cable | integrated-cable> wideband-channel** command can be used to display the IDs

**Note**

When a wideband channel is specified as a primary bonded channel in the DOCSIS configuration file, the channel must be identically specified as a primary bonded channel in the CMTS active, running configuration file. The **cable bonding-group-secondary** command specifies if a bonding group is a secondary bonding group. For information on this command, see the *Configuring the Cisco uBR-MC3GX60V Cable Interface Line Card* or the *Cisco uBR10012 Universal Broadband Router SIP and SPA Software Configuration Guide*.

Bonded Channel Enable

The bonded channel enable option is encoded as subtype 15:

- Type.Subtype—43.15
- Length—1
- Value—0 equals Disable, and 1 equals Enable

The bonded channel enable option allows the provisioning system to require that a wideband cable modem operate in DOCSIS 2.0 mode. When the bonded channel enable option has a value of 0 (disable), the CMTS ensures that a wideband-channel interface is not assigned to the wideband cable modem at registration time.

Only a single occurrence of the bonded channel enable option may be specified in the DOCSIS configuration file.

Secondary Bonding Group ID

The secondary bonding group ID option is encoded as subtype 16:

- Type.Subtype—43.16
- Length—2
- Value—secondary bonding group ID

The secondary bonding group ID option allows the provisioning system to specify secondary bonded downstream channels for the wideband cable modem to use. The modem can use one or two secondary bonded channels for multicast traffic. If the configured secondary bonding group ID is not valid, the CMTS causes the wideband cable modem to fail registration.

Up to two secondary bonding group IDs can be specified in the DOCSIS configuration file. The total of the RF channels in the primary and secondary bonded channels must comply with the 50-MHz capture-window limitation of the Linksys WCM300 modem.

**Note**

When a wideband channel is specified as a secondary bonded channel in the DOCSIS configuration file, the channel must be identically specified as a secondary bonded channel in the CMTS active, running configuration file. The **cable bonding-group-secondary** command specifies if a bonding group is a secondary bonding group. For information on this command, see *Configuring the Cisco uBR-MC3GX60V Cable Interface Line Card* or the *Cisco uBR10012 Universal Broadband Router SIP and SPA Software Configuration Guide*.

Scientific Atlanta DPC2505 and EPC2505 Wideband Cable Modems

**Note**

All interactions and behaviors described in this section for the Scientific Atlanta DPC2505 wideband cable modem are also applicable to the Scientific Atlanta EPC2505 wideband cable modem.

The Scientific Atlanta DPC2505 (EPC2505 for EuroDOCSIS) wideband cable modem makes use of the Broadcom Corporation BCM93381 cable modem chip. The BCM93381 chip provides three tuners, allowing the three downstream receivers to be independently tuned to any frequency. The M-CMTS and the Scientific Atlanta DPC2505 wideband cable modem use three downstream RF channels from the CMTS controller (one of which is the primary downstream channel) to form a wideband channel. The primary downstream channel is used for SYNCs, MAP, and other MAC management messages.

The Scientific Atlanta DPC2505 wideband cable modem uses a selected subset of the DOCSIS 3.0 protocol for channel bonding. Channel bonding is the transmission of a stream of packets across multiple RF channels with the use of sequence numbers to ensure the modem receiver delivers packets in the proper order to the CPE. The Scientific Atlanta DPC2505 wideband cable modem filters packets on a Destination Address and Security Association Identifier (SAID). The Scientific Atlanta DPC2505 modem supports up to 16 independent resequencing contexts.

The Scientific Atlanta DPC2505 wideband cable modem does not support multicast traffic on the wideband channel. Multicast service flows that the modem sees on the bonded downstream channel are discarded.

The configuration file used for the Scientific Atlanta DPC2505 wideband cable modem is identical to a DOCSIS 3.0 configuration file. DOCSIS 3.0 configuration file tools like the Cisco Broadband Configurator can be used to create configuration files for this modem.

CMTS Interactions with Wideband Modems

For the wideband-capable cable modems, this section provides information on the following:

- [Registration for Wideband Modems, page 6-80](#)
- [Automatic Adjustments During Registration, page 6-81](#)
- [Registration Load Balancing for Wideband Modems, page 6-81](#)

Registration for Wideband Modems

A wideband modem will scan downstream channel frequencies, stopping to analyze a channel if it has SYNC messages present, which is the first sign that the channel is primary-capable. Next the modem will analyze the channel for UCD messages, which describe upstream modulation details. The modem will then analyze for MDD messages, the contents of which will describe other channels available within the MAC domain service groups. A wideband modem will then send a B-INIT-RNG-REQ message in an upstream channel, notifying the CMTS of its presence. After the wideband cable modem completes the initialization process on the primary downstream channel, the CMTS uses the REG-RSP message to enable multiple downstream RF channel operations (wideband channel operation) and to assign channels to the cable modem.

Consistent with DOCSIS 3.0, the assignment of multiple channels takes place at two layers. The lower layer is that of physical receiver configuration, or the Receive Channel Set, of the cable modem. The CMTS uses a specific subset of DOCSIS 3.0 Receive Channel Configuration (RCC) encodings to inform the wideband cable modem what center frequencies to use for its primary downstream channel receiver and its two non-primary downstream channel receivers.

With a wideband cable modem as per DOCSIS 3.0, bonding and sequencing of traffic can take place across all channels of a Receive Channel Set of a cable modem, or across any subset of these channels. A second, higher layer of channel assignment deals with bonding and resequencing. This higher layer is handled by assignment of a Downstream Service Identifier (DSID) for each independent sequence number space. In the REG-RSP message, the CMTS uses a subset of DOCSIS 3.0 DSID encodings to inform the cable modem the DSID values to recognize, and the channels and resequencing timeouts that are associated with each DSID.

Automatic Adjustments During Registration

On receiving the REG-RSP message, the wideband modem first checks for presence and correctness of the various encodings.

- If any encodings are incorrectly formatted or exceed the capabilities of modem, the wideband cable modem may detect this and immediately send a REG-ACK message with a confirmation code indicating failure. The confirmation code will be reject-bad-rcc(208) if the RCC encoding is bad, or reject-other(1) if some other problem is found.
- If encodings appear to be valid, the wideband cable modem attempts to tune its non-primary receivers to the non-primary downstream channels specified in the RCC. The RCC may specify zero, one, or two non-primary downstream channels. If the cable modem fails to tune to the designated non-primary downstream channels, it will send a REG-ACK message with confirmation code reject-bad-rcc(208).

In the case of wideband channels overlapping on some sets of QAM channels, the wideband modem rejects the registration with confirmation code of reject-bad-rcc(208), which implies that something is wrong— either an incorrect plant topology configuration or a bad tuner in the cable modem. The CMTS records this occurrence. When the same cable modem tries to register again, the CMTS chooses different wideband channels preferably residing on different sets of QAM channels.

The process continues until the wideband cable modem successfully registers on a wideband channel or all choices of wideband channels are exhausted. If all choices are exhausted, the modem operates as a narrowband modem on its next attempt to register.

A timeout value of 24 hours is defined for the CMTS to clear the bad QAM status recorded for each cable modem. Therefore, the wideband cable modem is allowed to retry the bad set of QAM channels in the future.

Registration Load Balancing for Wideband Modems

If multiple wideband channels are available on the same fiber node, and the wideband cable modem comes online with one of the wideband channels, the CMTS has the choice of assigning it to a different wideband channel. In this case, a simple random load balancing algorithm distributes the cable modems on the fiber node across the multiple wideband channels.

If the CMTS has a choice between a wideband channel consisting of one RF channel and another channel consisting of two RF channels, the CMTS uses a weighted random load-balancing algorithm to determine the wideband channel that the wideband cable modem will use. The wideband channel with two RF channels is weighted so that it has two-thirds of a chance of being chosen while the wideband channel with one RF channel has one-third of a chance.

For more information on load balancing, see *Load Balancing and Dynamic Channel Change on the Cisco CMTS Routers* or the *Cisco uBR10012 Universal Broadband Router SIP and SPA Software Configuration Guide*.

Cisco SIP-600 and Gigabit Ethernet SPA Configuration

This section mentions the configuration tasks related to the Cisco SIP-600 and Gigabit Ethernet SPA:

- [Configuring the Cisco SIP-600, page 6-82](#)
- [Configuring the Gigabit Ethernet SPAs, page 6-82](#)

Configuring the Cisco SIP-600

The Cisco 10000 Series SPA Interface Processor-600 (referred to as the Cisco SIP-600) can support up to four Cisco Wideband SPAs. Two SIP-600s can support up to six Cisco Wideband SPAs plus Gigabit Ethernet SPAs. For more configuration information, see the chapter “Configuring a SIP” in the *Cisco uBR10012 Universal Broadband Router SIP and SPA Software Configuration Guide*.

Configuring the Gigabit Ethernet SPAs

The following Gigabit Ethernet SPAs are supported on the Cisco 10000 SIP-600 on the Cisco uBR10012 router in the Cisco IOS Release 12.2(33)SCB and later releases:

- 1 port 10-Gigabit Ethernet Shared Port Adapter, Version 2
- 5 port Gigabit Ethernet Shared Port Adapter, Version 2

**Note**

The 1 port 10-Gigabit Ethernet Shared Port Adapter is supported only on a PRE4 chassis.

For more configuration information on Gigabit Ethernet SPAs, see the chapter “Configuring Gigabit Ethernet SPAs” in the *Cisco uBR10012 Universal Broadband Router SIP and SPA Software Configuration Guide*.

Supported MIBs

The following MIBs are supported in Cisco IOS Release 12.3(23)BC and later releases for the Cisco uBR10012 router and the Cisco Wideband SIP and Wideband SPA:

The following MIBS have been added since Cisco IOS Release 12.3(23)BC:

- CLAB-TOPO-MIB
- DOCS-DIAG-MIB
- DOCS-DRF-MIB
- DOCS-IETF-CABLE-DEVICE-NOTIFICATION-MIB
- DOCS-IETF-QOS-MIB
- DOCS-IF3-MIB

- DOCS-IFEXT2-MIB
- DOCS-IF-M-CMTS-MIB
- DOCS-LOADBAL3-MIB
- DOCS-LOADBALANCING-MIB
- DOCS-MCAST-AUTH-MIB
- DOCS-MCAST-MIB
- DOCS-QOS3-MIB
- DOCS-SEC-MIB
- DOCS-SUBMGT3-MIB
- DOCS-TEST-MIB
- ENTITY-SENSOR-MIB

The following MIBS have been modified since Cisco IOS Release 12.3(23)BC:

- CISCO-CABLE-METERING-MIB
- CLAB-DEF-MIB
- DOCS-CABLE-DEVICE-MIB
- DOCS-CABLE-DEVICE-TRAP-MIB
- DOCS-DSG-IF-MIB
- DOCS-IETF-BPI2-MIB
- DOCS-IF-EXT-MIB
- DOCS-IF-MIB
- DOCS-QOS-MIB
- DOCS-SUBMGT-MIB

The following MIBS continue to be supported in Cisco IOS Release 12.3(23)BC:

- CISCO-CABLE-WIDEBAND-MIB
- CISCO-VENDORTYPE-OID-MIB

For information about MIBs associated with edge QAM devices or wideband cable modems, refer to the vendor documentation.

The following MIBs are supported by the Gigabit Ethernet SPAs on the Cisco uBR10012 router:

- ENTITY-MIB (RFC 2737)
- CISCO-ENTITY-ASSET-MIB
- CISCO-ENTITY-FRU-CONTROL-MIB
- CISCO-ENTITY-ALARM-MIB
- CISCO-ENTITY-EXT-MIB
- CISCO-ENTITY-SENSOR-MIB
- IF-MIB
- ETHERLIKE-MIB (RFC 2665)
- Remote Monitoring (RMON)-MIB (RFC 1757)
- CISCO-CLASS-BASED-QOS-MIB

- Ethernet MIB/RMON

The following MIBs are supported by the Cisco SIP-600 on the Cisco uBR10012 router:

- IF-MIB
- ENTITY-MIB

For more information on supported MIBs for the Cisco SIP-600 and Gigabit Ethernet SPAs, see the respective chapters “Overview of Cisco uBR10012 Router SIPs” and “Overview of Gigabit Ethernet SPAs” in the *Cisco uBR10012 Universal Broadband Router SIP and SPA Software Configuration Guide*.

For more information about MIB support on a Cisco uBR10012 router, refer to the *Cisco CMTS Universal Broadband Router MIB Specifications Guide*.

Known Restrictions

Cisco Wideband SPA Restrictions

The following restrictions apply to the *Cisco Wideband SPA* for Cisco IOS Release 12.3(23)BC:

- Voice call service flows are configurable only on wideband interfaces.
- Full DOCSIS QoS, including CIR support and downstream low latency service flows for voice, are configurable only on wideband interfaces.
- Dynamic services are configurable only on wideband interfaces.
- A wideband interface can only use RF channels from the same SPA.
- Scientific Atlanta DPC2505 and EPC2505 wideband cable modems support multicast traffic on the primary downstream channel only. These modems do not support multicast traffic on wideband downstream channels.

Cisco SIP-600 Restrictions

The following restrictions apply to the Cisco SIP-600 for Cisco IOS Release 12.2(33)SCB.

- The Cisco Wideband SIP (2 SPA bays) and the Cisco SIP-600 (4 SPA bays) cannot coexist on a Cisco uBR10012 router.
- The Cisco SIP-600 can be configured in Slot 1 and Slot 3 only, of the Cisco uBR10012 router.
- For a PRE4 setup, all SPAs share a 11.2Gbps ironbus connection.
- A PRE2 setup allows the typical ironbus connection in which Bay 0 and Bay 2 share a 2.8 Gbps ironbus connection and Bay 1 and Bay 3 also share a 2.8 Gbps ironbus connection.

For information on restrictions relevant to the Cisco SIP-600, see the section “Cisco SIP-600 Restrictions” and “WAN Slot Restrictions”, in the *Cisco uBR10012 Universal Broadband Router SIP and SPA Software Configuration Guide*.

Gigabit Ethernet SPA Restrictions

The following restrictions apply to the *Gigabit Ethernet SPAs* for Cisco IOS Release 12.2(33)SCB:

- When used as an uplink interface, the Cisco 1-port 10-Gigabit Ethernet SPA supports from one to ten VLANs with priority queues and class-based weighted-fair queues, based on QoS configuration and test scenarios. When QoS is applied at multiple VLAN 10-Gigabit Ethernet interfaces other than the main 10-Gigabit Ethernet interface, unexpected drops with nonpriority class queues may occur.
- As an access interface, the Cisco 1-port 10-Gigabit Ethernet SPA does not support oversubscription at the VLAN level when using QoS Model F.
- You cannot configure more than two active ports for sending and receiving packets on the Cisco 5 port Gigabit Ethernet SPA.
- The following features are not supported:
 - IEEE 802.1 Q-in-Q VLAN tag switching
 - Bridge protocol data units (BPDU) filtering

Cisco uBR-MC3GX60V Line Card Restrictions

The following restrictions apply to the Cisco uBR-MC3GX60V cable interface line card:

- All channels of a bonding group must come from the same controller.
- Cisco uBR-MC3GX60 MAC domains cannot use Wideband SPA downstream channels in Cisco IOS Release 12.2(33)SCF and earlier.



Note

Starting with Cisco IOS Release 12.2(33)SCG, Cisco uBR-MC3GX60V cable interface line cards and the Cisco Wideband SPA can coexist on a single chassis and share downstream channels. MAC domains hosted on the Cisco uBR-MC3GX60V line card can include downstream channels from the Cisco Wideband SPA.

For more information on the Cisco uBR-MC3GX60V line card restrictions, see *Configuring the Cisco uBR-MC3GX60V Cable Interface Line Card* at the following URL:

http://www.cisco.com/en/US/docs/interfaces_modules/cable/broadband_processing_engines/ubr_mc3gx60v/configuration/guide/mc3g60_cfg.html



Monitoring and Troubleshooting Narrowband and Wideband Components

This chapter provides an introduction to monitoring and troubleshooting the wideband components of the Cisco DOCSIS 3.0 Downstream Solution. The chapter includes the following topics:

- [Monitoring Narrowband and Wideband Components, page 7-1](#)
- [Troubleshooting Wideband Components, page 7-26](#)
- [Troubleshooting Gigabit Ethernet Components, page 7-42](#)

Monitoring Narrowband and Wideband Components

The Cisco IOS CLI includes commands that can be issued on the CMTS for the following:

- [Monitoring Wideband Line Cards, page 7-2](#)
- [Monitoring Wideband Channels, page 7-14](#)
- [Monitoring Narrowband RF Channels, page 7-18](#)
- [Monitoring Voice Services, page 7-22](#)
- [Monitoring Narrowband and Wideband Cable Modems, page 7-23](#)
- [Monitoring Cable MAC Domains, page 7-25](#)

For detailed information on the syntax, usage, and additional examples for each command, see the documents shown in [Table 7-1](#).



Note

Many of the commands used to configure the Cisco uBR10012 router and the Cisco Wideband SIP and Wideband SPA *are not* currently part of the command set that can be searched with the Cisco Command Lookup Tool (available on Cisco.com). Use the documents listed in [Table 7-1](#) to find information on these commands.

Table 7-1 Wideband Command Reference Documentation

Document	Command Described
<i>Cisco uBR10012 Universal Broadband Router SIP and SPA Software Configuration Guide</i>	Commands for the Cisco Wideband SIP and Cisco Wideband SPA, including commands for RF and wideband channels.
<i>Configuring the Cisco uBR-MC3GX60V Cable Interface Line Card</i>	Commands for configuring the Cisco uBR-MC3GX60V cable interface line card.
<i>Configuring the Cisco UBR-MC20X20V Cable Interface Line Card</i>	Commands for configuring the Cisco UBR-MC20X20V cable interface line card.
<i>Cisco IOS CMTS Cable Command Reference</i>	Commands for cable modems and cable interfaces (bonded and non-bonded channels).
<i>Cisco IOS Release 12.3 Commands Master Commands List</i>	Commands for Cisco IOS Release 12.3 that are not cable-specific.

Monitoring Wideband Line Cards

The following section provides commands used to monitor Cisco Wideband line cards:

- `show diag` for Wideband SIPs
- `show diag` for the Cisco uBR-MC3GX60V Line Card
- `show hw-module bay oir`
- `show diag` for Wideband SPA
- `show controllers modular-cable` for Cisco uBR-MC3GX60V Line Card
- `show controllers modular-cable <controller> sfp` for Cisco uBR-MC3GX60V Line Card
- `show controllers modular-cable` for Wideband SPA
- `show controllers cable`

The **show diag** command is useful for monitoring Cisco Wideband SPA, Wideband SIP, and wideband line cards. It shows basic information such as how long the card or wideband SPA (or SIP) has been up, its voltage status, and the software image version it is running.

In addition, the **show controllers modular-cable** and **show controllers jacket** commands displays extensive line card information including hardware device register values. The **show controllers** commands are intended for use only by Cisco Systems technical support personnel.

show diag for Wideband SIPs

To verify that the Wideband SIP is powered on, use the **show diag** command. If **show diag** displays any output, the Wideband SIP is powered on. The **show diag** command provides a variety of information on the Wideband SIP. In the following example, the hardware type of the Wideband SIP is 2jacket-1 card.

```
Router# show diag 1/0

Slot/Subslot 1/0:
  2jacket-1 card, 0 ports
  Card is full slot size
  Card is analyzed
  Card detected 16:46:44 ago
```



```

Card uptime 0 days, 16 hours, 46 minutes, 36 seconds
Card idle time 0 days, 14 hours, 22 minutes, 34 seconds
Voltage status: 3.3V Nominal 2.5V Nominal 1.5V Nominal 12V Nominal
EEPROM contents, slot 1/0:
Hardware Revision      : 1.0
Top Assy. Part Number : 800-22843-04
Board Revision        : 01
Deviation Number      : 0-0
Fab Version           : 04
PCB Serial Number     : CSJ09030613
RMA Test History      : 00
RMA Number            : 0-0-0-0
RMA History           : 00
CLEI Code             :
...

```

If **show diag** displays no output, the Wideband SIP is not powered on.

```
Router# show diag 1/0 // Displays no output
```

show diag for the Cisco uBR-MC3GX60V Line Card

To verify if the Cisco uBR-MC3GX60V line card is powered on, use the **show diag** command. If **show diag** displays any output, then the Cisco uBR-MC3GX60V line card is powered on.

```
router# show diag 5/0
```

```

Slot/Subslot 5/0:
ubr10k-clc-3g60 card, 15 ports
Card is half slot size
Card is analyzed
Card detected 02:34:34 ago
Card uptime 0 days, 2 hours, 35 minutes, 0 seconds
Card idle time N/A
Voltage status: 3.3V Nominal 2.5V Nominal 1.8V Nominal 1.5V Nominal 1.2V Nominal
1.0V Nominal 1.0V Nominal 1.1V Core Nominal 1.1V Cpu Plat Nominal
EEPROM contents, slot 5/0:
Controller Type       : 1629
Hardware Revision     : 1.11
Top Assy. Part Number : 800-33189-01
Top Assy. Revision    : 03
Product Identifier (PID) : UBR-MC3GX60V
Version Identifier (VID) : V01
CLEI Code             : NOCLEICODE
Deviation Number      : 0
Fab Version           : 03
PCB Serial Number     : CSJ13462929
RMA Test History      : 00
RMA Number            : 0-0-0-0
RMA History           : 00
Asset ID              : P1D-37
Asset Alias           : acme corp
License               : 72X60
Licensing Transaction ID : 72 DS, 60 US
Ordered Software PIDs :
    SWLIC-MC3GX60V-DS : 72
    SWLIC-MC3GX60V-US : 60
LCMON version, slot 5/0
Compiled Thu 17-Jun-10 02:39
Reset due to: power-on
Operational Image version, slot 5/0

```

```

Cisco IOS Software, 10000 Software (UBR10KG4CLC-LCK8-M), Experimental Version
12.2(20100928:051040) [release-view 140]
Compiled Fri 08-Oct-10 20:20 by jsmith
SW Version 1.0
Code MD5 BC9C0941705D7B99E2D1FC5C374824FB
FPGA MD5 00000000000000000000000000000000
Expected Switchover Action: NO INFORMATION

```

If **show diag** displays no output, then the Cisco uBR-MC3GX60V line card is not powered on.

```

Router# show diag 5/0
Router#

```

show hw-module bay oir

To verify that the Wideband SPA is powered on, use the **show hw-module bay oir** command. If the Operational Status is “ok,” the Wideband SPA is powered on and operational.

```

Router# show hw-module bay 1/0/0 oir

Module          Model                Operational Status
-----
bay 1/0/0      SPA-24XDS-SFP       ok

```

If the **show hw-module bay oir** command displays “admin down” in the Operational Status field, the Wideband SPA has been administratively disabled.

```

Router# show hw-module bay 1/0/0 oir

Module          Model                Operational Status
-----
bay 1/0/0      SPA-24XDS-SFP       admin down

```

show diag for Wideband SPA

To display hardware and diagnostic information for a Wideband SPA, use the **show diag** command for slot, subslot, and bay number.

```

Router# show diag 1/0/0

Slot/Subslot/Port 1/0/0:
 24rfchannel-spa-1 card, 1 port + 1 redundant port
Card is half slot size
Card is analyzed
Card detected 16:47:55 ago
Card uptime: Not Supported
Card idle time: Not Supported
Voltage status: 3.3V (+3.291) NOMINAL  2.5V (+2.495) NOMINAL
                1.2V (+1.201) NOMINAL  1.8V (+1.811) FIXED
EEPROM contents, slot 1/0/0:
Hardware Revision      : 1.0
Boot Timeout           : 500
PCB Serial Number     : CSJ09379726
Part Number            : 73-9597-03
Part Number Revision   : 05
Fab Version            : 03
RMA Test History       : 00
RMA Number             : 0-0-0-0

```

```

RMA History           : 00
Deviation Number     : 0
Product (FRU) Number : SPA-24XDS-SFP
Version Identifier (VID) : V01
Top Assy. Part Number : 68-2562-03
Board Revision       : 05
CLEI Code            :
MAC Address          : 0019.06a5.d9b2
MAC Address block size : 1
Manufacturing Test Data : 00 00 00 00 00 00 00 00
Field Diagnostics Data : 00 00 00 00 00 00 00 00
Calibration Data     : Minimum: 0 dBmV, Maximum: 0 dBmV
  Calibration values :
Platform features    : 00 00 00 00 00 00 00 00
                    : 00 00 00 00 00 00 00 00
                    : 00 00 00 00 00 00 00 00
                    : 00 00 00 00 00 00 00 00

```

show controllers modular-cable for Cisco uBR-MC3GX60V Line Card

The **show controllers modular-cable** command for Cisco uBR-MC3GX60V line card has a number of options:

Table 7-2 *show controllers modular-cable Command Options*

Options	Description
all	Displays all M-CMTS information.
association	Displays interface association information.
bpi-entry	Displays BPI information
brief	Displays brief M-CMTS information
config	Displays JIB3DS configuration information
counters	Displays channel counters.
crashinfo	Displays CLC crash information
errors	Displays errors encountered.
fpga_version	Displays FPGA version.
ge_phy	Displays Gigabit Ethernet PHY information.
iofpga	Displays IOFPGA information.
mapping	Displays mapping of WB and RF Channels.
registers	Displays JIB3DS registers.
rf-channel	Displays RF channels.
sfp	Displays SFP information.
status	Displays JIB3DS status.
wideband-channel	Displays wideband channels.

In the following example, the **brief** keyword option displays information such as per channel configuration status and hardware registers, which contains configuration and status.

```
router# show controllers modular-Cable 5/0/2 brief
```

```
Modular Cable Controller 5/0/2:
```

```
-----
Channel 49 Annex = B Modulation = 256 QAM
Channel 50 Annex = B Modulation = 256 QAM
Channel 51 Annex = B Modulation = 256 QAM
Channel 52 Annex = B Modulation = 256 QAM
Channel 53 Annex = B Modulation = 256 QAM
Channel 54 Annex = B Modulation = 256 QAM
Channel 55 Annex = B Modulation = 256 QAM
Channel 56 Annex = B Modulation = 256 QAM
Channel 57 Annex = B Modulation = 256 QAM
Channel 58 Annex = B Modulation = 64 QAM
Channel 59 Annex = B Modulation = 256 QAM
Channel 60 Annex = B Modulation = 256 QAM
Channel 61 Annex = B Modulation = 256 QAM
Channel 62 Annex = B Modulation = 256 QAM
Channel 63 Annex = B Modulation = 256 QAM
Channel 64 Annex = B Modulation = 256 QAM
Channel 65 Annex = B Modulation = 256 QAM
Channel 66 Annex = B Modulation = 256 QAM
Channel 67 Annex = B Modulation = 256 QAM
Channel 68 Annex = B Modulation = 256 QAM
Channel 69 Annex = B Modulation = 256 QAM
Channel 70 Annex = B Modulation = 256 QAM
Channel 71 Annex = B Modulation = 256 QAM
Channel 72 Annex = B Modulation = 256 QAM
```

```
Jib3-DS Device Information:
```

```
-----
Jib3-DS Version = 2.2.1.13
SW Rev ID = 0x00020002 HW Rev ID = 0x0001000D
Device Type: Coldplay 3G60
Driver State: 3
Device Object Address: 0x1F7CE480
Ironbus Base Channel: 0xC02
```

```
Channel Resources:
```

```
-----
Total Non-bonded Channels.....= 72
Per-Controller Non-bonded Channels = 24
Total Bonded Channels.....= 96
Per-Controller Bonded Channels.....= 32
```

```
Slot-Wide Resources:
```

```
-----
Number of PHS Rules.....= 12K (0x3000)
Number of BPI Table Entries...= 24K (0x6000)
Number of Service Flows.....= 64K (0x10000)
```

```
Santana FPGA brief
```

```
-----
SANTANA device initialized : YES
SANTANA device status : 00000007
SANTANA ERP CLK DLL LOCKED: YES
SANTANA CORE CLK DLL LOCKED: YES
SANTANA ERP DLL CLKIN LOST: NO
SANTANA CORE DLL CLKIN LOST: NO
```

```
SANTANA Registers
```

san_fpga_rev_id	Addr[0xF8900000] Offset[0x0000] = [0x00000001]
san_hw_fpga_rel_id	Addr[0xF8900004] Offset[0x0004] = [0x00000006]
san_control_reg	Addr[0xF8900010] Offset[0x0010] = [0x00000000]
san_status_reg	Addr[0xF8900020] Offset[0x0020] = [0x00000007]
san_fatal_int_first	Addr[0xF890003C] Offset[0x003C] = [0x00000000]
san_glb_isr_reg	Addr[0xF8900040] Offset[0x0040] = [0x00000000]
san_fatal_int_src	Addr[0xF8900050] Offset[0x0050] = [0x00000000]
san_fatal_int_en	Addr[0xF8900054] Offset[0x0054] = [0x0000007F]
san_testpoint_select_reg	Addr[0xF8900060] Offset[0x0060] = [0x00000000]
san_testpoint_reg	Addr[0xF8900064] Offset[0x0064] = [0x00000001]
san_proc_irq_src_reg	Addr[0xF8900400] Offset[0x0400] = [0x00000000]
san_proc_irq_en_reg	Addr[0xF8900404] Offset[0x0404] = [0x0000001F]
san_erp_tp_sel	Addr[0xF8900450] Offset[0x0450] = [0x00000000]
san_erp_tp	Addr[0xF8900454] Offset[0x0454] = [0x00000000]
san_erp_cfg	Addr[0xF8900460] Offset[0x0460] = [0x00000000]
san_erp_err_record	Addr[0xF8900464] Offset[0x0464] = [0x00000000]
san_erp_err_addr	Addr[0xF8900468] Offset[0x0468] = [0x00000000]
san_erp_err_wd_record	Addr[0xF890046C] Offset[0x046C] = [0x00000000]
san_proc_err_addr	Addr[0xF8900490] Offset[0x0490] = [0x00000000]
san_en_traffic	Addr[0xF89008A8] Offset[0x08A8] = [0x00000021]
san_egres_frm0qam_log_reg	Addr[0xF89008AC] Offset[0x08AC] = [0x00000000]
san_egres_frm1qam_log_reg	Addr[0xF89008B0] Offset[0x08B0] = [0x00000000]
san_egres_frm2qam_log_reg	Addr[0xF89008B4] Offset[0x08B4] = [0x00000000]
san_egres_frm0qam_prio_log_reg	Addr[0xF89008B8] Offset[0x08B8] = [0x00000000]
san_egres_frm1qam_prio_log_reg	Addr[0xF89008BC] Offset[0x08BC] = [0x00000000]
san_egres_frm2qam_prio_log_reg	Addr[0xF89008C0] Offset[0x08C0] = [0x00000000]
san_egres_frm0tun_prio_log_reg	Addr[0xF89008C4] Offset[0x08C4] = [0x00000000]
san_egres_frm1tun_prio_log_reg	Addr[0xF89008C8] Offset[0x08C8] = [0x00000000]
san_egres_frm2tun_prio_log_reg	Addr[0xF89008CC] Offset[0x08CC] = [0x00000000]
san_egres_frm0tun_log_reg	Addr[0xF89008D0] Offset[0x08D0] = [0x00000000]
san_egres_frm1tun_log_reg	Addr[0xF89008D4] Offset[0x08D4] = [0x00000000]
san_egres_frm2tun_log_reg	Addr[0xF89008D8] Offset[0x08D8] = [0x00000000]
san_total_col2san_pkt_cnt	Addr[0xF8901000] Offset[0x1000] = [0x0015A738]
san_frm0_byp_pkt_drp_cnt	Addr[0xF8901024] Offset[0x1024] = [0x00000000]
san_frm1_byp_pkt_drp_cnt	Addr[0xF8901028] Offset[0x1028] = [0x00000000]
san_frm2_byp_pkt_drp_cnt	Addr[0xF890102C] Offset[0x102C] = [0x00000000]
san_frm0_qam_in_pkt_drp_cnt_addr_reg	Addr[0xF8901048] Offset[0x1048] = [0x00000018]
san_frm1_qam_in_pkt_drp_cnt_addr_reg	Addr[0xF890104C] Offset[0x104C] = [0x00000018]
san_frm2_qam_in_pkt_drp_cnt_addr_reg	Addr[0xF8901050] Offset[0x1050] = [0x00000018]
san_frm0_qam_in_pkt_drp_cnt_data_reg	Addr[0xF890106C] Offset[0x106C] = [0x00000000]
san_frm1_qam_in_pkt_drp_cnt_data_reg	Addr[0xF8901070] Offset[0x1070] = [0x00000000]
san_frm2_qam_in_pkt_drp_cnt_data_reg	Addr[0xF8901074] Offset[0x1074] = [0x00000000]
san_frm0_qam_pkt_drp_cnt_addr_reg	Addr[0xF8901078] Offset[0x1078] = [0x00000001]
san_frm1_qam_pkt_drp_cnt_addr_reg	Addr[0xF890107C] Offset[0x107C] = [0x00000001]
san_frm2_qam_pkt_drp_cnt_addr_reg	Addr[0xF8901080] Offset[0x1080] = [0x00000001]
san_frm0_qam_pkt_drp_cnt_data_reg	Addr[0xF8901084] Offset[0x1084] = [0x00000000]
san_frm1_qam_pkt_drp_cnt_data_reg	Addr[0xF8901088] Offset[0x1088] = [0x00000000]
san_frm2_qam_pkt_drp_cnt_data_reg	Addr[0xF890108C] Offset[0x108C] = [0x00000000]
san_gmac0_taildrop_pkt_cnt_reg	Addr[0xF8901300] Offset[0x1300] = [0x00000000]
san_gmac1_taildrop_pkt_cnt_reg	Addr[0xF8901304] Offset[0x1304] = [0x00000000]
san_gmac2_taildrop_pkt_cnt_reg	Addr[0xF8901308] Offset[0x1308] = [0x00000000]
san_gmac3_taildrop_pkt_cnt_reg	Addr[0xF890130C] Offset[0x130C] = [0x00000000]
san_gmac4_taildrop_pkt_cnt_reg	Addr[0xF8901310] Offset[0x1310] = [0x00000000]
san_gmac5_taildrop_pkt_cnt_reg	Addr[0xF8901314] Offset[0x1314] = [0x00000000]
san_ipac_drop_pkt_cnt_reg	Addr[0xF8901318] Offset[0x1318] = [0x00000000]
san_san2col_pkt_cnt_reg	Addr[0xF890131C] Offset[0x131C] = [0x00000006]
san_san2col_loopback_pkt_cnt_reg	Addr[0xF8901320] Offset[0x1320] = [0x00000000]
san_ipac_err_pkt_cnt_reg	Addr[0xF8901324] Offset[0x1324] = [0x00000000]
san_ipac_none_depi_pkt_cnt_reg	Addr[0xF8901328] Offset[0x1328] = [0x00000006]
san_ipac_depi_ctrl_pkt_cnt_reg	Addr[0xF890132C] Offset[0x132C] = [0x00000000]
san_ipac_depi_dlm_pkt_cnt_reg	Addr[0xF8901330] Offset[0x1330] = [0x00000000]
san_egress_bp_thresh0_reg	Addr[0xF8900884] Offset[0x0884] = [0x00008844]
san_egress_irq_src_reg	Addr[0xF8900888] Offset[0x0888] = [0x00000000]

```

san_egress_irq_enb_reg      Addr[0xF890088C] Offset[0x088C] = [0x0003FFFF]
san_egress_fifo_full_reg   Addr[0xF8900894] Offset[0x0894] = [0x00000000]
san_egress_fifo_emp_reg    Addr[0xF8900898] Offset[0x0898] = [0x0007FFFF]
san_egress_fifo_ovfl_reg   Addr[0xF890089C] Offset[0x089C] = [0x00000000]
san_egress_fifo_ufl_reg    Addr[0xF89008A0] Offset[0x08A0] = [0x00000000]
san_egress_fifo_perr_reg   Addr[0xF89008A4] Offset[0x08A4] = [0x00000000]
san_ingress_irq_src_reg    Addr[0xF8900CA0] Offset[0x0CA0] = [0x00000015]
san_ingress_irq_enb_reg    Addr[0xF8900CA4] Offset[0x0CA4] = [0x00000FC0]
san_ingress_fifo_full_reg  Addr[0xF8900CAC] Offset[0x0CAC] = [0x00000000]
san_ingress_fifo_emp_reg   Addr[0xF8900CB0] Offset[0x0CB0] = [0x000FFFFF]
san_ingress_fifo_ovfl_reg  Addr[0xF8900CB4] Offset[0x0CB4] = [0x00000000]
san_ingress_fifo_ufl_reg   Addr[0xF8900CB8] Offset[0x0CB8] = [0x00000000]
san_ingress_fifo_perr_reg  Addr[0xF8900CBC] Offset[0x0CBC] = [0x00000000]
san_gmac_stats_data_reg    Addr[0xF8902000] Offset[0x2000] = [0x000005BF]
san_gmac_stats_addr_reg    Addr[0xF8902004] Offset[0x2004] = [0x00000000]

```

show controllers modular-cable <controller> sfp for Cisco uBR-MC3GX60V Line Card

To monitor the SFPs plugged into the Cisco uBR-MC3GX60V line card, use the **show controller modular-cable <controller> sfp** command. It displays the SFP presence, manufacturer, and most importantly, link status. The Cisco uBR-MC3GX60V line card has six SFP ports, ports 0 to 5.

The example below shows that an SFP is plugged into Port 4, but not 5 and the SFP present has an UP link state.

```

router# show controllers modular-Cable 5/0/2 sfp

SFP in Port4 is Present.  Init status Success <<<—SFP 4 is present
    TX_DISABLE not set, LOS not detected, TX_FAULT not detected
    LOS detection supported: no
    Tx Fault detection supported: no
SFP Interrupt Counts:
    LOS:0, PRES:0, TX_FAULT:0
Link Status of the MV88E1146C DS Gige Phy Port: UP <<<— link is up

DEV_SHOW_ALL for SFP:4

3G60 SFP:
  ID: SFP
  Extended ID: 4
  Xcvr Type: GE T (1A)
  Connector: unknown
  Encoding: 8B10B
  Bit Rate: 1300 Mbps
  Copper supported length: 100 m
  Upper bit rate limit: not specified
  Lower bit rate limit: not specified
  Date code (yy/mm/dd): 09/04/20
  Vendor name: CISCO-AVAGO
  Vendor OUI: 5994
  Vendor Part Number (PN): ABCU-5710RZ-CS2
  Vendor Rev:
  Vendor SN (SN): AGM131620Y4
  Options implemented:
    TX Disable Signal
  Enhanced options implemented: none
  Diagnostic monitoring implemented: none
  Idprom contents (hex):
  0x00:  03 04 00 00 00 00 08 00 00 00 00 01 0D 00 00 00
  0x10:  00 00 64 00 43 49 53 43 4F 2D 41 56 41 47 4F 20
  0x20:  20 20 20 20 01 00 17 6A 41 42 43 55 2D 35 37 31

```

```

0x30:  30 52 5A 2D 43 53 32 20 20 20 20 20 41 0C C1 13
0x40:  00 10 00 00 41 47 4D 31 33 31 36 32 30 59 34 20
0x50:  20 20 20 20 30 39 30 34 32 30 20 20 00 00 00 AE
0x60:  00 00 06 90 39 AC E3 A7 43 49 F3 17 7B E1 30 B8
0x70:  19 04 B3 00 00 00 00 00 00 00 00 00 2A 30 86 F8
0x80:  FF FF FF FF FF FF FF FF FF FF FF FF FF FF FF FF
0x90:  FF FF FF FF FF FF FF FF FF FF FF FF FF FF FF FF
0xA0:  FF FF FF FF FF FF FF FF FF FF FF FF FF FF FF FF
0xB0:  FF FF FF FF FF FF FF FF FF FF FF FF FF FF FF FF
0xC0:  FF FF FF FF FF FF FF FF FF FF FF FF FF FF FF FF
0xD0:  FF FF FF FF FF FF FF FF FF FF FF FF FF FF FF FF
State: Enabled
SW TX Fault: unavailable
SW LOS: unavailable

```

```

Phased Initialization
Phase Reached: 4
Phase Exit Code: Success 0
Phase Read Offset: 0

```

Socket Verification

```

SFP PHY Registers
Register 0x00:  0140 016D 0141 0CC1 0C01 CDE1 000D 2801
Register 0x08:  45AF 0E00 3800 0000 0000 0000 0000 F000
Register 0x10:  0078 AC4C 0000 0000 0000 0C68 0000 0000
Register 0x18:  4100 0000 000A 9088 0000 0000 0000 0000
SFP in Port5 is NOT PRESENT <<<— SFP 5 is not present

```

show controllers modular-cable for Wideband SPA

The Wideband SPA is a controller and the **show controllers modular-cable** command displays information about the SPA, its Gigabit Ethernet ports, installed SFP modules, wideband channels, and so on.

The following example provides sample **show controllers modular-cable** output for the Wideband SPA located in slot 1, subslot 0, bay 0 of a Cisco uBR10012 router. In the output, the Gigabit Ethernet Port Selected field indicates that Port 1 is the active Gigabit Ethernet port on the Wideband SPA.

```
Router# show controllers modular-cable 1/0/0 brief
```

```

SPA 0 is present
status LED: [green]
Host 12V is enabled and is okay.
Power has been enabled to the SPA.
SPA reports power enabled and okay.
SPA reports it is okay and is NOT held in reset.

Gigabit Ethernet Port Selected : Port 1
Receive Interface           : In Reset
Receive Interface           : Disabled
Transmit Interface          : Out of Reset
Transmit Interface          : Enabled
Primary Receive Clock       : Disabled
Backup Receive Clock        : Disabled
SFP [Port 0] : 1000BASE-SX Present
Tx Enabled , LOS Detected , TxFault Not Detected
Link Status [Port 0] : DOWN

SFP [Port 1] : 1000BASE-T Present
Tx Enabled , LOS Not Detected , TxFault Not Detected

```

Link Status [Port 1] : UP

Wideband Channel information

Channel	RF bitmap	Police	Info: Bytes	Interval
0	0x3		0	0 ms
1	0xC		0	0 ms
2	0x30		0	0 ms
3	0xC0		0	0 ms
4	0x300		0	0 ms
5	0xC00		0	0 ms
6	0x3000		0	0 ms
7	0xC000		0	0 ms
8	0x30000		0	0 ms
9	0x0		0	0 ms
10	0x0		0	0 ms
11	0x0		0	0 ms

RF Channel information

Modulation corresponds to : QAM 256

Annex corresponds to : Annex B

Modulation Data :GE Interframe Gap = 12 , MPEG-TS Frames per pkt = 4

SPA IP address = 0.0.0.0

SPA MAC Addr = 0012.001A.888B

QAM	Channel Rate	Rate adjust	State
0	0	1	Enabled
1	0	1	Enabled
2	0	1	Enabled
3	0	1	Enabled
4	0	1	Enabled
5	0	1	Enabled
6	0	1	Enabled
7	0	1	Enabled
8	0	1	Enabled
9	0	1	Enabled
10	0	1	Enabled
11	0	1	Enabled
12	0	1	Enabled
13	0	1	Enabled
14	0	1	Enabled
15	0	1	Enabled
16	0	1	Enabled
17	0	1	Enabled
18	0	1	Enabled
19	0	1	Enabled
20	0	1	Enabled
21	0	1	Enabled
22	0	1	Enabled
23	0	1	Enabled

Interrupt Counts

Idx	Interrupt Register	Interrupt Bit	Total Count	Masked:
69	blz_sp_int_stat_reg_0	spi_train_vld	24	YES
84	spa_brd_int_stat_reg	sp_int_0	24	NO
85	spa_brd_int_stat_reg	scc_int	2	NO
86	spa_brd_int_stat_reg	phy1_int	1	NO
87	spa_brd_int_stat_reg	phy0_int	1	NO
92	spa_brd_int_stat_reg	templ_int	2	NO
93	spa_brd_int_stat_reg	temp0_int	2	NO
97	bm_int_stat_reg	bm_spa_brd	26	NO

To display information about the SFP module in a Wideband SPA port, use the **show controllers modular-cable** with the **sfp** keyword. In the following example, the information is for the SFP module in Port 1 is displayed.

```

Router# show controllers modular-cable 1/0/0 sfp port 1

SFP in port 1
SFP is present
SFP LOS is not detected
SFP TX FAULT is not detected
SFP TX is enabled

ID: SFP
  Extended ID: 4
  Connector: LC
  SONET compliance: not specified
  Gigabit Ethernet compliance: 1000BASE-SX
  Fibre Channel link length: not specified
  Fibre Channel transmitter technology: not specified
  Fibre Channel transmission media: not specified
  Fibre Channel speed: not specified
  Encoding: 8B10B
  Bit Rate: 1300 Mbps
  50 micron-multimode fiber supported length: 550 m
  62.5 micron-multimode fiber supported length: 270 m
  Upper bit rate limit: not specified
  Lower bit rate limit: not specified
  Date code (yy/mm/dd): 05/02/23
  Vendor name: CISCO-AGILENT
  Vendor OUI: 12499
  Vendor Part Number (PN): QFBR-5766LP           Vendor Rev:
  Vendor SN (SN): AGS090855CE
  Options implemented:
    LOS Signal
    TX Fault Signal
    TX Disable Signal
  Enhanced options implemented: none
  Diagnostic monitoring implemented: none
  Idprom contents (hex):
  0x00:  03 04 07 00 00 00 01 00 00 00 00 01 0D 00 00 00
  0x10:  37 1B 00 00 43 49 53 43 4F 2D 41 47 49 4C 45 4E
  0x20:  54 20 20 20 00 00 30 D3 51 46 42 52 2D 35 37 36
  0x30:  36 4C 50 20 20 20 20 20 20 20 20 03 52 00 B5
  0x40:  00 1A 00 00 41 47 53 30 39 30 38 35 35 43 45 20
  0x50:  20 20 20 20 30 35 30 32 32 33 20 20 00 00 00 C4
  0x60:  00 00 06 C9 F0 FA 7C 01 B3 C8 41 6B 39 04 FC 85
  0x70:  BB 20 9E 00 00 00 00 00 00 00 00 00 00 B4 94 52 CC
  0x80:  FF FF FF FF FF FF FF FF FF FF FF FF FF FF FF FF
  0x90:  FF FF FF FF FF FF FF FF FF FF FF FF FF FF FF FF
  State: Initalized

Phased Initialization
  Phase Reached: 4
  Phase Exit Code: 0
  Phase Read Offset: 0
...

```

show controllers cable

To display information about RF channels and their attributes that are added to the cable MAC domain, use the **show controllers cable slot/subslot/port downstream** command. This applies to all MAC domain card types, Cisco uBR-MC5X20, Cisco UBR-MC20X20V, Cisco uBR-MC8X8V, and Cisco uBR-MC3GX60V line cards.

The following configuration shows the modular-cable interface channels of a SPA in bay 1/1/0 added to the MAC domain c8/0/0:

```
Router# show run interface c8/0/0 | inc Modular-Cable

downstream Modular-Cable 1/1/0 rf-channel 1 upstream 1
downstream Modular-Cable 1/1/0 rf-channel 4 upstream 0
downstream Modular-Cable 1/1/0 rf-channel 7 upstream 0
```

The MAC domain configuration shown in the preceding configuration provides the following SPA RF downstream channel information in the **show controllers cable slot/subslot/port downstream** command output (in this example, the output is for cable 8/0/0 where a uBR-MC5X20 line card is in subslot 8/0):

```
Router# show controllers cable 8/0/0 downstream

Cable8/0/0 Downstream is up <<<— local MC5X20 downstream
Frequency 459.0000 MHz, Channel Width 6 MHz, 64-QAM, Symbol Rate 5.056941 Msps
FEC ITU-T J.83 Annex B, R/S Interleave I=32, J=4
Downstream channel ID: 119
Dynamic Services Stats:
DSA: 0 REQs 0 RSPs 0 ACKs
0 Successful DSAs 0 DSA Failures
DSC: 0 REQs 0 RSPs 0 ACKs
0 Successful DSCs 0 DSC Failures
DSD: 0 REQs 0 RSPs
0 Successful DSDs 0 DSD Failures
DCC: 0 REQs 0 RSPs 0 ACKs
0 Successful DCCs 0 DCC Failures
DCC end of transaction counts:
DCC unknown cause(0) offline(0) if down(0) no cm(0)
DCC no resource(0) no retries(0) reject(0) unknown state (0)
DCC rebuild err (0) T15 timeout(0) wrong channel(0) reinit MAC (0)
DCC dcc succeeds(0)
DCC wcm(0)
Local total modems 0, modems active 0, total DS flows 1
NB DS Mo 1/1/0:1, STATE: UP
Frequency 561.0000 MHz 64-QAM, ANNEX B, R/S Interleave I=32, J=4
Network Delay 550 (usec)
Bandwidth (Kbps): 1078, Load Percent: 0
Channel ID: 49, US MAP: 0x0002
Total modems: 2, modems active : 2, total DS flows: 3
NB DS Mo 1/1/0:4, STATE: UP
Frequency 717.0000 MHz 64-QAM, ANNEX B, R/S Interleave I=32, J=4
Network Delay 550 (usec)
Bandwidth (Kbps): 2697, Load Percent: 0
Channel ID: 52, US MAP: 0x0001
Total modems: 6, modems active : 6, total DS flows: 7
NB DS Mo 1/1/0:7, STATE: UP
Frequency 735.0000 MHz 64-QAM, ANNEX B, R/S Interleave I=32, J=4
Network Delay 550 (usec)
Bandwidth (Kbps): 1078, Load Percent: 0
Channel ID: 55, US MAP: 0x0001
Total modems: 0, modems active : 0, total DS flows: 1

DS_chan_id  RFID  Interface
-----
49          25   Mo 1/1/0:1
52          28   Mo 1/1/0:4
55          31   Mo 1/1/0:7
-----

MDDs          Primary          Non-Primary
-----
1/1/0:1       6300              0
1/1/0:4       6299              0
1/1/0:7       6298              0
-----
```

Upstream Controller Monitoring

To display information about the number of MAP and UCD MAC management messages sent on a DS channel (that has been added to primary-capable channels that are part of a MAC domain), use the **show controllers cable slot/subslot/port upstream** command.

The following configuration shows the modular-cable interface channels added to the MAC domain c8/0/0:

```
Router# show run interface c8/0/0 | inc Modular-Cable

downstream Modular-Cable 1/1/0 rf-channel 1 upstream 1
downstream Modular-Cable 1/1/0 rf-channel 4 upstream 0
downstream Modular-Cable 1/1/0 rf-channel 7 upstream 0
```

The MAC domain configuration shown in the preceding configuration provides the following information for US channels associated with SPA DS channels that are added to the MAC domain in the **show controllers cable slot/subslot/port upstream** command output (in this example, the output is for cable8/0/0):

```
Router# show controllers cable 8/0/0 upstream 0

Cable8/0/0 Upstream 0 is up
  Frequency 11.400 MHz, Channel Width 3.200 MHz, Symbol Rate 2.560 Msps
  Modulations (64-QAM) - A-short 64-QAM, A-long 64-QAM, A-ugs 64-QAM
  Mapped to non-shared connector 2 and receiver 2
  Spectrum Group is overridden
  MER(SNR) - Unknown - no modems online.
  Nominal Input Power Level 0 dBmV, Tx Timing Offset 0
  Ranging Backoff Start 3, Ranging Backoff End 6
  US timing offset adjustment type 0, value 0
  Ranging Insertion Interval automatic (60 ms)
  US throttling off
  Tx Backoff Start 3, Tx Backoff End 5
  Modulation Profile Group 221
  Concatenation is enabled
  Fragmentation is enabled
  part_id=0x3140, rev_id=0x03, rev2_id=0x00
  nb_agc_thr=0x0000, nb_agc_nom=0x0000
  Range Load Reg Size=0x58
  Request Load Reg Size=0x0E
  Minislot Size in number of Timebase Ticks is = 2
  Minislot Size in Symbols = 32
  Bandwidth Requests = 0x0
  Piggyback Requests = 0x0
  Invalid BW Requests= 0x0
  Minislots Requested= 0x0
  Minislots Granted = 0x0
  Minislot Size in Bytes = 24
  Map Advance (Dynamic) : 2830 usecs
  Map Count Local = 6540889
  No MAP buffer= 0x0   No Remote MAP buffer= 0x0
  Map Counts Remote: Controller 1/1/0 = 26148778
  UCD Count = 6651
  Remote UCD Counts:
    Controller 1/1/0:4 = 6646
    Controller 1/1/0:7 = 6646
  ATDMA mode enabled
  PHY: us errors 0 us recoveries 0 (enp 0)
  MAC PHY TSS: tss error start 0 tss error end 0
  MAC PHY Status: bcm3140 status 0 lookout status 0
```

```

PHY: TSS late 0 discontinuous 0
PHY: TSS mis-match 0 not-aligned 0
PHY: TSS missed snapshots from phy 0
MAP/UCD Replication Instructions:
  Controller 1/1/0 index = 121, bitmap = 0x0090
Dynamic Services Stats: <<<—Useful for voice services monitoring
DSA: 0 REQs 0 RSPs 0 ACKs
0 Successful DSAs 0 DSA Failures
DSC: 0 REQs 0 RSPs 0 ACKs
0 Successful DSCs 0 DSC Failures
DSD: 0 REQs 0 RSPs
0 Successful DSDs 0 DSD Failures
Dropped MAC messages: (none)

```

The Dynamic Services Stats section is useful in voice services monitoring. If an upstream is too congested, DOCSIS dynamic services messages may be dropped in the upstream and those drops will be counted and reflected in the command output.

Monitoring Wideband Channels

The following commands are useful for monitoring wideband channels:

- [show interface wideband-cable](#)
- [show hw-module bay and show controller](#)

show interface wideband-cable

To display information about a wideband-cable interface (wideband channel), use the **show interface wideband-cable** command. Wideband channels are similar to cable interfaces and information about them is also displayed with the **show ip interfaces** and **show interfaces** commands.

The following example displays the **show interface wideband-cable** command output for wideband channel 0 on the Wideband SPA in slot/subslot/bay 1/0/0.

```

Router# show interface wideband-cable 1/0/0:0

Wideband-Cable1/0/0:0 is up, line protocol is up
  Hardware is Wideband CMTS Cable interface, address is 0012.001a.8896 (bia
0012.001a.8896)
  MTU 1500 bytes, BW 74730 Kbit, def 74730 Kbit DLY 1000 usec,
    reliability 255/255, txload 1/255, rxload 1/255
  Encapsulation MCNS, loopback not set
  Keepalive set (10 sec)
  ARP type: ARPA, ARP Timeout 04:00:00
  Last input never, output 00:00:16, output hang never
  Last clearing of "show interface" counters never
  Input queue: 0/75/0/0 (size/max/drops/flushes); Total output drops: 0
  Queueing strategy: fifo
  Output queue: 0/40 (size/max)
  30 second input rate 0 bits/sec, 0 packets/sec
  30 second output rate 0 bits/sec, 0 packets/sec
    0 packets input, 0 bytes, 0 no buffer
    Received 0 broadcasts, 0 runts, 0 giants, 0 throttles
    0 input errors, 0 CRC, 0 frame, 0 overrun, 0 ignored, 0 abort
    17470 packets output, 1810488 bytes, 0 underruns
    0 output errors, 0 collisions, 0 interface resets
    0 output buffer failures, 0 output buffers swapped out

```

Hardware Status and Line Protocol Status for a Wideband-Channel and Modular-Cable Interface

When a wideband-channel cable interface is specified in the **show interface wideband-cable** command or another Cisco IOS command that displays hardware status (initializing, down, up, or administratively down) and line protocol status (down or up) for a cable interface, the following applies:

- In the case of a Wideband SIP and SPA, the hardware status for a wideband cable interface will be up if the Wideband SPA is installed in the Wideband SIP, and both are powered on, and config mode has been entered for the interface.
- In the case of a Cisco uBR-MC3GX60V or Cisco UBR-MC20X20V line card, the hardware status for a wideband-cable interface will be up if the line card is installed, powered on, and config mode has been entered for the interface at least once.
- The line protocol for a wideband-channel cable interface will be up if the wideband channel is associated with at least one RF channel by configuration and the following parameters have been set for the RF channel:
 - Frequency
 - IP-address
 - MAC-address
 - DEPI-remote-id

If the line protocol for a wideband cable interface is up, all wideband cable configuration information needed to successfully send data is present. However, additional configuration information may be needed to complete the Wideband SPA configuration process. For more information on Wideband SPA configuration procedures, see the *Cisco uBR10012 Universal Broadband Router SIP and SPA Software Configuration guide*.

For more information about the Cisco UBR-MC20X20V line card based wideband-cable interface, see [Configuring the Cisco UBR-MC20X20V Cable Interface Line Card guide](#).

For more information about the Cisco uBR-MC3GX60V line card based wideband-cable interface, see [Configuring the Cisco uBR-MC3GX60V Cable Interface Line Card guide](#).

When a modular-cable interface is specified in the **show interface modular-cable** command or another Cisco IOS command that displays hardware status and line protocol status for a cable interface, such as the **show ip interfaces brief** command, the following applies:

- In the case of a Wideband SIP and SPA, the hardware status for a modular-cable interface will be up if the Wideband SPA is installed in the Wideband SIP and both are powered on.
- In the case of a Cisco UBR-MC20X20V line card, the hardware status for a integrated-cable interface will be up if the line card is installed, powered on, and config mode has been entered for the interface at least once.
- In the case of a Cisco uBR-MC3GX60V line card, the hardware status for an modular-channel cable interface will be up if the line card is installed, powered on, and config mode has been entered for the interface at least once.
- The line protocol for a modular-cable interface will be up if the following settings have been applied to the RF channel:
 - The upstream channels from the MAC domain cable interface line card must be associated with the modular-cable interface or integrated-cable downstream channels in a given cable MAC domain.
 - The total bandwidth allocated for the interface must be greater than or equal to 1 percent.

- In the case of a Wideband SPA, the modular host must be configured on the modular-cable controller for the corresponding SPA. The modular-host is the line card responsible for managing per-modem BPI, PHS, and DSID indexes.
- In the case of an M-CMTS modular-cable interface, a DEPI remote ID must be configured for this channel. The UDP port number must not be configured in this case.
- RF channel frequency parameter must be set for the RF channel.

show hw-module bay and show controller

To display additional information about a wideband channel of a Wideband SPA, use the **show hw-module bay** commands. Use the **show controller modular-cable** commands for a Cisco uBR-MC3GX60V line card, and the **show controller integrated-cable** commands for a Cisco UBR-MC20X20V line card. You can then specify one of the following keywords indicating the particular type of information you want to display:

- **association**—Displays wideband-to-narrowband MAC domain association information. The association of a wideband channel to a MAC domain is made when a primary downstream channel for the fiber node is configured with the **downstream** command and the wideband interface channels are also in the fiber node.
- **config**—Displays wideband channel configuration information.
- **counters wideband-channel**—Displays wideband channel statistics.
- **mapping**—Displays the mapping of RF channels to wideband channels.

To display wideband-to-narrowband channel association (the MAC domains using the wideband channel) information, use the **show hw-module bay command** with the **association** and **wideband-channel** keywords. If you specify a wideband channel number after the **wideband-channel** keyword, the output is shown only for that channel:

```
Router# show hw-module bay 1/0/0 association wideband-channel 0
```

WB channel	BG ID	Bundle num	NB channel	NB chan ID	Reserved CIR	Total CIR
Wideband-Cable1/0/0:0	24	1	Cable5/0/1	120	0	0

In the preceding example, the following information is displayed for each wideband channel:

Table 7-3 *show hw-module bay association wideband-channel Command Output Field Descriptions*

Field	Description
WB channel	Wideband-cable interface (wideband channel).
BG ID	Bonding-group ID for the wideband channel.
Bundle num	Number of the virtual bundle interface where the wideband channel is a member.
NB channel	Slot/subslot/port of the for MAC domains using for the wideband channel.
NB channel ID	DOCSIS channel ID for the primary downstream channel. Because the Cisco UBR-MC20X20V and Cisco uBR-MC3GX60V line cards do not natively have a local downstream channel, the ID will show as 0 in these cases.

Table 7-3 *show hw-module bay association wideband-channel Command Output Field Descriptions*

Field	Description
Reserved CIR	Reserved committed information rate (CIR). Because CIR is not currently supported for wideband traffic, reserved CIR is always 0.
Total CIR	CIR that is currently available.

To display the configuration information for a wideband channel, use the **show hw-module bay command** with the **config** and **wideband-channel** keywords. If you do not specify a wideband channel number after the **wideband-channel** keyword, the output is shown for all wideband channels:

```
Router# show hw-module bay 1/0/0 config wideband-channel

WB          BG    Bundle  WB Host      Primary
channel     ID    num     Slot/Subslot BG
Wideband-Cable1/0/0:0  1    123     5/0          Yes
Wideband-Cable1/0/0:1  2    123     5/0          Yes
Wideband-Cable1/0/0:2  3    123     5/0          Yes
Wideband-Cable1/0/0:3  4    123     5/0          Yes
Wideband-Cable1/0/0:4  5    123     5/0          Yes
Wideband-Cable1/0/0:5  6    123     5/0          Yes
Wideband-Cable1/0/0:6  7    123     5/0          Yes
Wideband-Cable1/0/0:7  8    123     5/0          Yes
Wideband-Cable1/0/0:8  9    123     5/0          Yes
Wideband-Cable1/0/0:9  10   123     5/0          Yes
Wideband-Cable1/0/0:10 11   123     5/0          Yes
Wideband-Cable1/0/0:11 12   123     5/0          Yes
```

In the preceding example, the following information is displayed for each wideband channel:

Table 7-4 *show hw-module bay config wideband-channel Output Field Description*

Field	Description
Wideband Channel	Wideband channel.
BG ID	Bonding-group ID.
Bundle num	Number of the virtual bundle interface where the wideband channel is a member.
WB Host Slot/Subslot	Cable interface line card that has been configured for Wideband protocol operations. For information, see the modular-host subslot command in the <i>Cisco uBR10012 Universal Broadband Router SIP and SPA Software Configuration Guide</i> .
Primary BG	Primary bonding group (primary wideband channel). "Yes" indicates that the wideband channel is a primary bonding group.

To display wideband-channel statistics, use the **show hw-module bay command** with the **counters** and **wideband-channel** keywords.

```
Router# show hw-module bay 1/0/0 counters wideband-channel 0

SPA          WB channel  Tx packets          Tx octets
```

```
1/0/0    0                29069                4032392
```

To display RF channels that have been configured for a wideband channel, use the **show hw-module bay command** with the **mapping** and **wideband-channel** keywords. The **BW%** column displays the percentage of the RF channel bandwidth that is assigned to the wideband channel with the **cable rf-channel** command.

```
Router# show hw-module bay 1/0/0 mapping wideband-channel
```

SPA	WB channel	RF channel	BW %
1/0/0	0	0	100
		1	100
1/0/0	1	2	100
		3	100
1/0/0	2	4	100
		5	100
1/0/0	3	6	100
		7	100
1/0/0	4	8	100
		9	100
1/0/0	5	10	100
		11	100
1/0/0	6	12	100
		13	100
1/0/0	7	14	100
		15	100
1/0/0	8	16	100
		17	100
1/0/0	9	18	100
		19	100
1/0/0	10	20	100
		21	100
1/0/0	11	22	100
		23	100

Monitoring Narrowband RF Channels

The following commands are useful for monitoring narrowband RF channels:

- [show interface modular-cable and show interface integrated-cable](#)
- [show hw-module bay](#)
- [show controller modular-cable and show controller integrated-cable](#)

show interface modular-cable and show interface integrated-cable

To display information about narrowband interfaces, use the **show interface modular-cable** or **show interface integrated-cable** command. Narrowband interfaces information is also displayed with the **show ip interface** and **show interfaces** command.

The following is sample output of the **show interface modular-cable** command:

```
Router# show interface modular-cable 1/0/0:0

Modular-Cable3/0/0:0 is up, line protocol is up
Hardware is CMTS MC interface, address is 0011.9221.84be (bia 0011.9221.84be)
MTU 1500 bytes, BW 539 Kbit, DLY 1000 usec,
    reliability 255/255, txload 1/255, rxload 1/255
```



```

Encapsulation MCNS, loopback not set
Keepalive set (10 sec)
ARP type: ARPA, ARP Timeout 04:00:00
Last input never, output 00:09:57, output hang never
Last clearing of "show interface" counters never
Input queue: 0/75/0/0 (size/max/drops/flushes); Total output drops: 0
Queueing strategy: PXF First-In-First-Out
Output queue 0/64, 0 drops; input queue 0/75, 0 drops
5 minute input rate 0 bits/sec, 0 packets/sec
5 minute output rate 0 bits/sec, 0 packets/sec
  0 packets input, 0 bytes, 0 no buffer
  Received 0 broadcasts, 0 runts, 0 giants, 0 throttles
  0 input errors, 0 CRC, 0 frame, 0 overrun, 0 ignored, 0 abort
  107 packets output, 16302 bytes, 0 underruns
  0 output errors, 0 collisions, 0 interface resets
  0 output buffer failures, 0 output buffers swapped out

```

You can also specify the following keywords to display more specific information you would like to display:

Table 7-5 *show interface modular-cable Output Field Description*

Field	Description
accounting	Displays interface accounting information
controller	Displays interface status, configuration, and controller status.
counters	Displays interface counters.
crb	Displays interface routing and bridging information.
description	Displays interface description.
dml	Displays DLM statistics.
downstream	Displays downstream information.
fair-queue	Displays interface Weighted Fair Queueing (WFQ) information.
irb	Displays interface routing and bridging information.
mac-accounting	Displays interface MAC accounting information.
monitor	Displays the interface information continuously.
mpls-exp	Displays interface MPLS experimental accounting information.
multicast-gr	Displays multicast QoS GCR Details.
multicast-sessions	Displays multicast sessions information.
precedence	Displays interface precedence accounting information.
random-detect	Displays interface weighted random early detection (WRED) information.
stats	Displays interface packets & octets, in & out, by switching path.
summary	Displays interface summary.

show hw-module bay

To display information about RF channels on a Wideband SPA, use the **show hw-module bay** command with the **rf-channel** keyword. You also have to specify one of the following keywords indicating the particular type of information you want to display:

- **config**—Displays RF channel configuration information.
- **counters**—Displays RF channel statistics.
- **mapping**—Displays the mapping of RF channels to wideband channels.

To display configuration information for an RF channel, use the **show hw-module bay command** with the **config** and **rf-channel** keywords. If you specify an RF channel number after the **rf-channel keyword**, output is for that channel only. For example, the following output is for RF channel 0 on the Wideband SPA located in slot/subslot/bay 1/0/0.

```
Router# show hw-module bay 1/0/0 config rf-channel 0
```

Freq	Mod	Anx	IP Address	MAC Address	UDP Port/	If	Idx
chnl						DEPI	
						Remote Id	
1/1/0	0	555000000	256qam B	10.30.4.100	0090.f001.53eb	37721	1209

In the preceding output, these fields provide information on the edge QAM device that is associated with the RF channel:

- IP address—IP address of the edge QAM device.
- MAC address—MAC address of the next-hop or edge QAM device.
- DEPI ID or UDP port—DEPI ID or UDP port number for the edge QAM device that will be used for this RF channel.

To display MPEG packets transmitted for an RF channel, use the **show hw-module bay command** with the **counters** and **rf-channel** keywords.

```
Router# show hw-module bay 1/0/0 counters rf-channel 0
```

MPEG	MPEG	Sync	MAP Queue				
Chan	Packets Tx		bps	Mbps	Packets Tx	Packets Tx	
1/1/0	0	826196333	13722746	13.722	870613	521229533	

show controller modular-cable and show controller integrated-cable

For the Cisco uBR-MC3GX60V and Cisco UBR-MC20X20V line card, the **config**, **counters**, and the **mapping** commands shown in the preceding configuration are displayed with the **show controller** command.

The **config** command displays all aspects of the configuration for the controller and its channels.

To display configuration information for an RF channel, use the **show controller modular-cable rf-channel** command.

The following example shows how to display the configuration information for the rf-channel 0 on the modular interface 5/0/0:

```
router# show controllers modular-Cable 5/0/0 rf-channel 0
```

Ctrl	Chan	Frequency	Mod	Annex	IP Address	MAC Address	DEPI	Remote ID
0	0	453000000	256	B	10.31.136.100	0022.9084.4e3f	101111	

To display the per RF channel packet counts, bandwidth usage, SYNC, MAP, and non-SYNC and MAP packet counts use the **counters rf** command. This command is used to monitor channel saturation and the distribution of bandwidth in the cable plant.

For the Cisco Wideband SPA and Cisco UBR-MC20X20V line card, the channel bandwidth usage is computed based on the MPEG frames, each of which is 188 bytes.

For the Cisco uBR-MC3GX60V line card, the channel bandwidth is computed based on the DMPT (DOCSIS MPEG Transport) frames, which are a composite of MPEG frames.

The following example displays the output of the **show controller modular cable counter rf** command for the Cisco uBR-MC3GX60V line card:

```
router# show controller modular-Cable 5/0/1 counter rf
```

Contr Med Pkts	RF Chan Tx	Pkts Tx	Bytes Tx	Pkts Dropped	DMPT Mbps	DMPT* pps	Sync Pkts Tx	MAP/UCD Pkts Tx
5/0/1	0	359422902	175839786632	0	16.084494	3278	17695916	
348630355		131188						
5/0/1	1	297919977	144703086948	0	12.776285	2464	17695915	
348630335		100908						
5/0/1	2	411173896	205063220844	0	19.152506	3965	17695915	
348630323		121152						
5/0/1	3	533449227	289471796988	0	28.142993	5570	17695914	
348630315		170136						
5/0/1	4	416414672	208106842144	0	19.457173	4016	17695913	
349494926		122964						
5/0/1	5	359411966	177779675348	0	16.280459	3274	17695913	
349494918		105723						
5/0/1	6	358961974	177630830860	0	16.316326	3277	17695912	
349494906		105728						
5/0/1	7	493909136	263091994564	0	22.212102	4431	17695910	
349494858		157423						
5/0/1	8	359861407	176357816120	0	16.148563	3277	17695905	
349424219		106805						
5/0/1	9	298273856	145360324608	0	12.855633	2467	17695904	
349424215		88482						
5/0/1	10	460787085	235328615916	0	22.350009	4596	17695904	
349424199		143407						
5/0/1	11	393417481	387085290468	0	38.185439	3677	17695903	
349424191		161748						
5/0/1	12	404324991	393733309244	0	38.130136	3775	17695903	
327307195		109146						
5/0/1	13	404351002	393679365464	0	38.128834	3772	17695902	
327307183		171286						
5/0/1	14	404379728	393645455340	0	38.130587	3770	17695901	
327307175		129867						
5/0/1	15	297584535	142519536884	0	12.589738	2460	17695901	
327307163		88480						
5/0/1	16	293331958	141265632720	0	12.439508	2410	17695899	
292640661		88483						
5/0/1	17	327924662	160476865612	0	12.441312	2409	17695898	
292640655		125175						
5/0/1	18	386874510	191388404840	0	15.774166	3245	17695898	
292640643		143530						
5/0/1	19	436449376	225386019716	0	21.717130	4352	17695897	
292640629		143562						
5/0/1	20	442427	83204476	0	0.003756	2	0	0
442395								
5/0/1	21	442463	83199588	0	0.003756	2	0	0
442395								
5/0/1	22	442462	83198836	0	0.003756	2	0	0
442395								
5/0/1	23	442455	83197144	0	0.003756	2	0	0
442395								

```
Total:      7699994148      4628246671304      0      429.328417 70493 353918123
6669989064      4284773
*Does not include DEPI control plane or DLM packets.
```

The following example displays the **show controllers integrated-Cable counter rf** command output for the Cisco UBR-MC20X20V line card:

```
router# show controllers integrated-Cable 7/0/0 counter rf 0

Controller RF      MPEG      MPEG      MPEG      Sync      MAP/UCD
           Chan    Packets    bps       Mbps      Packets   Packets
           Tx      Tx         Tx         Tx         Tx         Tx
7/0/0      0      0          0          0.000000  0          0
```

The **mapping** command shows the relationship between RF channels and wideband channels. A wideband channel is always built from one or more RF channels.

The following example shows that the rf-channel 0 is used in both a 4-channel and a 8-channel wideband channel, specifically wideband channel 5/0/0:1 and 5/0/0:2:

```
router# show controllers modular-Cable 5/0/0 mapping rf-channel 0

Ctrlr    RF      MC      MC Rem.    WB      WB      WB Rem.
        channel BW %    Ratio    channel  BW %    Ratio
5/0/0    0      5      1          5/0/0:1  50     1
                    5/0/0:2  20     1
```

```
router# show controllers modular-Cable 5/0/0 mapping wb 1
```

```
Ctrlr    WB      RF      BW %    Remaining
        channel channel
5/0/0    1      5/0/0:0  50     1
                    5/0/0:1  50     1
                    5/0/0:2  50     1
                    5/0/0:3  50     1
```

```
router # show controllers modular-Cable 5/0/0 mapping wb 2
```

```
Ctrlr    WB      RF      BW %    Remaining
        channel channel
5/0/0    2      5/0/0:0  20     1
                    5/0/0:1  20     1
                    5/0/0:2  20     1
                    5/0/0:3  20     1
                    5/0/0:4  20     1
                    5/0/0:5  20     1
                    5/0/0:6  20     1
                    5/0/0:7  20     1
```

Monitoring Voice Services

The **show cable service-voice downstream-type** command is useful for monitoring voice services:

```
Router# show cable service-voice downstream-type

Slot 5/1 :      HA-capable-DS      MDC-DS
Slot 6/0 :      HA-capable-DS      MDC-DS
```

The output shown above indicates that both, HA-capable-DS and MDC-DS are enabled for voice services for slot/subslots 5/1 and 6/0.

Monitoring Narrowband and Wideband Cable Modems

The following commands are useful for monitoring wideband cable modems:

- **show cable modem wideband**
- **show cable modem summary**
- **show cable modem primary**
- **show cable modem primary-channel**
- **show cable modem voice**

Many other **show cable** commands display information on wideband cable modems if a wideband cable modem or a cable interface used for a wideband cable modem is specified in the command's arguments. Some examples of these commands are:

- **show cable modem vendor**
- **show cable modem cnr**
- **show cable modem errors**
- **show cable modulation profile**
- **show interface cable privacy**

show cable modem wideband

To display information for registered and unregistered wideband cable modems, use the **show cable modem wideband** command:

```
Router# show cable modem wideband
```

MAC Address	IP Address	I/F	MAC State	Prim Sid	RCC ID	MD-DS-SG/ MD-US-SG
0019.474a.c2a6	50.3.81.31	C5/0/5/U0	w-online(pt)	6	3	1 / N/A
0018.6852.82fe	50.3.81.64	C5/0/8/U0	w-online(pt)	1	3	1 / N/A
0019.474a.d4e0	50.3.81.57	C5/0/8/U0	w-online(pt)	2	3	1 / N/A
0019.474a.d310	50.3.81.56	C5/0/8/U0	w-online(pt)	3	3	1 / N/A

With the **show cable modem wideband** command, you can specify a particular wideband cable modem by IP address or MAC address. You can also specify a set of wideband cable modems that are on a particular cable interface.

[Table 7-6](#) describes the fields that are shown in the **show cable modem wideband** display.

Table 7-6 *show cable modem wideband Field Description*

Field	Description
MAC Address	MAC address of the cable modem.
IP Address	IP address that the DHCP server has assigned to the cable modem.
I/F	Cable interface providing the upstream for this cable modem.

Table 7-6 *show cable modem wideband Field Description (continued)*

Field	Description
MAC State	Current state of the MAC layer. For information on MAC states, see the show cable modem wideband command in the <i>Cisco Broadband Cable Command Reference Guide</i> .
Prim SID	Primary SID assigned to this cable modem.
RCC ID	Receive Channel Configuration identifier of the modem. Further information on the RCC can be shown with the show cable mac-domain <interface> rcc command.
MD-DS-SG	MAC domain downstream service group. The downstream channels of a single MAC domain that reach the cable modem.
MD-US-SG	MAC domain upstream service group. The upstream channels of a single MAC domain that reach the cable modem.

Further information about a particular modem may be obtained using the **show cable modem verbose** command.

Registered-traditional Subcommand

To monitor wideband-capable modems that are registered as DOCSIS 1.x or DOCSIS 2.0 modems and are not showing up with status w-online, use the **show cable modem wideband registered-traditional-docsis** command.

show cable modem summary

To display the summary information of the cable modems, including modems registered as wideband cable modems, use the **show cable modem summary** command:

```
Router# show cable modem summary
```

Interface	Cable Modem								Description			
	Total	Reg	Oper	Unreg	Offline	Wideband	initRC	initD	initIO	initO		
C5/0/1/U0	11	11	11	0	0	0	0	0	0	0		
C6/0/1/U0	11	11	11	0	0	0	0	0	0	0		

The following example displays summary information and totals for the set of cable modems on a range of cable interfaces (in this example, cable 5/1/1 to cable 5/1/2).

```
Router# show cable modem summary c5/1/1 c5/1/2 total
```

Interface	Cable Modem								Description			
	Total	Reg	Unreg	Offline	Wideband	initRC	initD	initIO	initO			
C5/1/1/U0	84	84	0	0	84	0	0	0	0			
C5/1/1/U1	84	84	0	0	83	0	0	0	0			
C5/1/1/U2	83	83	0	0	83	0	0	0	0			
C5/1/1/U3	83	83	0	0	83	0	0	0	0			
C5/1/2/U0	84	84	0	0	84	0	0	0	0			
C5/1/2/U1	84	84	0	0	84	0	0	0	0			
C5/1/2/U2	83	83	0	0	83	0	0	0	0			
C5/1/2/U3	83	83	0	0	83	0	0	0	0			
Total:	668	668	0	0	667	0	0	0	0			

show cable modem primary

To display which primary channel the modem is using, use the **show cable modem primary** command:

```
Router# show cable modem primary
```

MAC Address	IP Address	Host	MAC	Prim	Num	Primary	DS
		Interface	State	Sid	CPE	Downstream	RfId
0018.6852.7f02	80.27.0.10	C8/0/0/U0	w-online	1	0	Mo1/1/0:4	28
0018.6852.7ee2	80.27.0.2	C8/0/0/U1	online	2	0	C8/0/0	255
0018.6852.7ef8	80.27.0.6	C8/0/0/U0	w-online	6	0	Mo1/1/0:4	28
0018.6852.7ef2	80.27.0.7	C8/0/0/U1	w-online	7	0	Mo1/1/0:1	25
0018.6852.7ef6	80.27.0.8	C8/0/0/U1	w-online	8	0	Mo1/1/0:1	25

show cable modem primary-channel

To display the primary-channel and host interface for all modems or for modems on a MAC domain host interface, use the **show cable modem primary-channel** command:

```
Router# show cable modem primary-channel non-bonding-capable
```

MAC Address	IP Address	Host	MAC	Prim	Num	Primary	DS
		Interface	State	Sid	CPE	Downstream	RfId
000f.66f9.aa73	80.17.1.3	C6/0/0/U0	online(pt)	1	0	C6/0/0	255
0007.0e02.d7e9	80.17.1.7	C6/0/0/U0	online(pt)	5	0	Mo3/0/0:1	1
0013.10bb.22f9	80.17.1.2	C6/0/0/U0	online(pt)	2	0	Mo3/0/0:1	1
000f.66f9.b193	80.17.1.6	C6/0/0/U0	online(pt)	22	0	C6/0/0	255
0012.17ea.f3fb	80.17.1.4	C6/0/0/U0	online(pt)	23	0	C6/0/0	255
0013.10bb.23d1	80.17.1.5	C6/0/1/U1	online(pt)	5	0	C6/0/1	255

show cable modem voice

To show the detected voice-enabled modems, use the **show cable modem voice** command:

```
Router# show cable modem voice
```

MAC Address	IP Address	Host	MAC	Prim	Num	Primary	DS
		Interface	State	Sid	CPE	Downstream	RfId
0013.10bb.22f9	80.17.1.2	C6/0/0/U0	online(pt)	2	0	Mo3/0/0:1	1
0013.10bb.23d1	80.17.1.5	C6/0/1/U1	online(pt)	5	0	C6/0/1	255

Monitoring Cable MAC Domains

The following commands are useful for monitoring the cable MAC domains:

- [show cable mac-domain downstream-service-group](#)
- [show cable mac-domain cgd-associations](#)

show cable mac-domain downstream-service-group

To display MAC domain downstream service group information for a primary downstream channel, use the **show cable mac-domain downstream-service-group** command. The service-group is determined from the channels placed in the fiber nodes; therefore, if fiber nodes are being reconfigured, use this command to check if the downstream service-group is updated.

The following example displays **show cable mac-domain downstream-service-group** output for the primary downstream channel on the cable interface at slot/subslot/port 5/0/0:

```
Router# show cable mac-domain cable5/0/0 downstream-service-group
```

```
Primary MD-DS-SG RF
IF Id SPA Chan
C5/0/0 1 1/0/0 0 - 1
```

In the preceding example, the MD-DS-SG with ID 1 is used for RF channels 0 and 1 on the Wideband SPA located in slot/subslot/bay 1/0/0.

The following example displays the **show cable mac-domain downstream-service-group** output of two 8-channel downstream service groups for a Cisco uBR-MC3GX60V MAC domain.

```
router# show cable mac-domain ca6/0/0 downstream-service-group
```

```
Cable MD-DS-SG RF
IF Id Resource Chan Primary Chan
C6/0/0 1 6/0/0 00-03 0 1 2 3
      20-23
      2 6/0/0 00-03 0 1 2 3
      20-22
```

show cable mac-domain cgd-associations

To display a summary of the channel grouping domain (CGD) associations for a MAC domain, use the **show cable mac-domain <interface> cgd-associations** command.

The following is sample output of the **show cable mac-domain cgd-associations** command for the cable interface at slot 5, subslot 0, and port 0:

```
Router# show cable mac-domain c5/0/0 cgd-associations
```

```
CGD Host SPA DS Channels Upstreams (All) Active Remote DS
Ca5/0/0 Local 1 Y
      1/0/0 0-1 0
```

The preceding example shows the following information for the cable MAC domain host, which is the cable interface at slot 5, subslot 0, and port 0:

- The SPA downstream channels 0 and 1 from the SPA slot 1, subslot 0, and bay 0 have been added to this MAC domain.

Upstream 1 is associated with the Cisco uBR10-MC5X20 downstream channel. If the **All** column in the command output indicates **Y**, then this indicates that all upstream channels are associated with the Cisco uBR10-MC5x20 line card downstream channels (in this case, one or more SPA downstream channels are configured using the **upstream cable connector** command). If all upstream channels are not configured, then this column will not display.

Troubleshooting Wideband Components

This section provides an introduction to troubleshooting the wideband components of the Cisco DOCSIS 3.0 Downstream Solution:

- [Troubleshooting Power Up Issues, page 7-27](#)
- [Troubleshooting DOCSIS Timing and Control Card, page 7-29](#)
- [Troubleshooting EQAM Connectivity Issues of the M-CMTS, page 7-31](#)
- [Troubleshooting Primary-Capable Channel DOCSIS Signalling, page 7-33](#)

- [Troubleshooting Power Up Issues, page 7-27](#)
- [Troubleshooting Wideband Channels, page 7-37](#)
- [Troubleshooting Wideband Cable Modems, page 7-39](#)

The following Cisco cable documents provide useful information on troubleshooting the non-wideband components of the Cisco uBR10012 router:

- *Cisco uBR10012 Universal Broadband Router Troubleshooting Guide*
- “Troubleshooting the System” chapter in the *Cisco uBR10012 Universal Broadband Router Software Configuration Guide*
- *Online Offline Diagnostics—Field Diagnostics on Cisco uBR10012 Router User’s Guide*

For information on troubleshooting non-Cisco components (such as edge QAM devices) used in the Cisco DOCSIS 3.0 Downstream Solution, see the vendor documentation for the device.

**Note**

Complex troubleshooting procedures are beyond the scope of this document and may involve Cisco TAC or Advanced Services support, or both.

The following are basic troubleshooting steps to get wideband modems online and their CPEs pingable:

1. Line card is powered on.
2. For M-CMTS, DTI timing is functioning.
3. For M-CMTS, Gigabit Ethernet ports are up.
4. For M-CMTS, EQAM ping.
5. Controller configuration is complete.
6. Primary-capable state of the MC or IC interfaces.
7. Fiber-node configuration is complete, fiber-node status valid.
8. MAC domain configuration is complete.
9. MC interface or IC interface status is up.
10. RF channel bandwidth usage for the primary channels.
11. No RF impairment on non-primary channels.

All these troubleshooting procedures are discussed in detail in the rest of the chapter.

Troubleshooting Power Up Issues

This section describes troubleshooting techniques for a Wideband SIP or Wideband SPA. It includes the following sections:

- [Performing Basic Power Troubleshooting on a Wideband SIP and Wideband SPA, page 7-28](#)
- [Performing Basic Power Troubleshooting on the Cisco uBR-MC3GX60V Line Card, page 7-28](#)
- [Verifying the Up State of an Active Gigabit Ethernet Port of a Wideband SPA, page 7-31](#)
- [Verifying That a Wideband SPA Is Correctly Configured for SPA-to-EQAM Communications, page 7-36](#)

- [Verifying That a Wideband SPA Is Able to Communicate with the Edge QAM Device, page 7-36](#)

Performing Basic Power Troubleshooting on a Wideband SIP and Wideband SPA

To perform basic troubleshooting on a Wideband SIP and Wideband SPA, complete the following steps:

	Action	More Information or Example						
Step 1	Use the show diag command to check that a Wideband SIP is powered on.	<pre>Router# show diag 1/0 Slot/Subslot 1/0: 2jacket-1 card, 0 ports Card is full slot size Card is analyzed Card detected 0:3:16 ago Card uptime 0 days, 0 hours, 3 minutes, 17 seconds ...</pre> <p>If show diag displays output, the Wideband SIP is powered on. If show diag displays no output, the Wideband SIP is not powered on.</p>						
Step 2	Check that the Wideband SIP FAIL LED is not on.	The FAIL LED is turned on by default and turned off by software after basic board functionality has been verified. If the SIP FAIL LED remains on, the SIP has failed to initialize or has encountered an error.						
Step 3	Use the show hw-module bay oir command to check that a Wideband SPA is powered on.	<pre>Router# show hw-module bay 1/0/0 oir</pre> <table border="1"> <thead> <tr> <th>Module</th> <th>Model</th> <th>Operational Status</th> </tr> </thead> <tbody> <tr> <td>bay 1/0/0</td> <td>SPA-24XDS-SFP</td> <td>ok</td> </tr> </tbody> </table> <ul style="list-style-type: none"> • If the Operational Status is “ok,” the Wideband SPA is powered on and operational. • If the Operational Status is “admin down,” the Wideband SPA is not powered on. 	Module	Model	Operational Status	bay 1/0/0	SPA-24XDS-SFP	ok
Module	Model	Operational Status						
bay 1/0/0	SPA-24XDS-SFP	ok						
Step 4	Check that the Wideband SPA STATUS LED is lit green.	<ul style="list-style-type: none"> • If the STATUS LED is green, the SPA is ready and operational. • If the STATUS LED is amber, SPA power is on and good, and the SPA is being configured. • If the STATUS LED is off, SPA power is off. 						
Step 5	If cables are connected to one or both of the SPA Gigabit Ethernet port SFP modules and the links for these should be up, check that the Wideband SPA A/L (Active Loopback) LEDs are lit green.	<ul style="list-style-type: none"> • If the A/L LED is green, the port is enabled and the link is up. • If the A/L LED is amber, the port is enabled and the link is down. • If the A/L LED is off, the port is not enabled. 						

Performing Basic Power Troubleshooting on the Cisco uBR-MC3GX60V Line Card

To perform the basic power troubleshooting on a Cisco uBR-MC3GX60V line card, execute the **show diag** command on the subslot, the card is plugged into. If no output is displayed, then the card is not powered on.

Check for the following, in case the card is not powered on:

- Card has been inserted correctly and is screwed in.

- There are no extraneous subslot **shutdown** commands in the configuration preventing the card from booting up. To perform this, execute the **show running | include hw-mod.*shutdown** command.

If the **show diag** command does not display any output and the card is not powered off by configuration, physically examine the card faceplate and check the Fail LED status. If it is on, then the line card is not booting correctly.

**Note**

When using a Cisco uBR-MC3GX60V line card, the empty slots in the Cisco uBR10012 router chassis must be filled with blank filler cards to maximize the air flow and keep the line cards functioning within proper thermal boundaries.

Troubleshooting DOCSIS Timing and Control Card

This section describes troubleshooting techniques for the DOCSIS Timing and Control Card (DTCC). It includes the following sections:

- [Verifying Active DTCC and Status, page 7-29](#)
- [Verifying DTI Counters, page 7-30](#)
- [Verifying DTI Clock Synchronization, page 7-30](#)

Verifying Active DTCC and Status

For the M-CMTS network architecture, DTI-based timing must be enabled using the **cable clock dti** command in global config mode. If DTI timing does not functioning correctly, cable modems do not reach the init() state.

To determine the active DTCC and its current status, use the **show cable clock** command:

```
Router# show cable clock

Number of TCC Cards in the Chassis: 1
Active TCC Card is in slot: 1 subslot: 1, (DTCC Eightbells card) Clock reference used by
the active card is DTI

Active TCC card in slot 1/1
TCC Card 1/1 DTI status:
-----
Active Client port: 2
Active Client status: normal
Active Client Server status: freerun
Active Client frame error rate : < 2%
Active Client CRC error count : 0xFC
Standby Client Signal detected : no

No card in slot 2/1
```

If the Cisco uBR10012 chassis has two DTCCs, this command can be used to determine which DTCC is active. If the DTI client has established communications with a DTI server, the **show cable clock** command displays the current status. If the active DTCC is connected to a DTI server that is delivering a DOCSIS time stamp and frequency, the Active Client status displays as normal. However, if the connection to the DTI server is lost, the Active Client status displays as freerun (see previous example).

**Note**

When a DTI server is first powered on, it may stay in the warmup state until its internal oscillator has stabilized. This may take more than 15 minutes.

Verifying DTI Counters

To display the DTI counters for the clock card, use the **show cable clock dti counters slot/subslot** command.

The following example displays the **show cable clock dti counters slot/subslot** command output for slot 1 and subslot 1:

```
Router> show cable clock dti counters 1/1

TCC Card 1/1 DTI counters:
----- Client Normal time: 0xFFFF Client Holdover
time: 0x0000
Client Phase Correction: 0x0000
Client Freq Correction: 0xFBD7
Client EFC Correction: 0xF7AD Client transition count t3: 0x00
Client transition count t4: 0x01
Client transition count t6: 0x00
Client transition count t7: 0x00
```

Verifying DTI Clock Synchronization

Three main components in the M-CMTS system need to have a synchronized DOCSIS clock:

1. CMTS DTCC card
2. CMTS cable line card, and
3. EQAM

To verify the CMTS timing at the DTCC and MAC domain card, enter the following three commands in rapid succession:

- `show cable clock dti client 1/1 | i Timestamp`
- **show controller Cable5/0/0 | i Timestamp**
- On the CISCO RFGW10 EQAM, execute the **show cable clock | i timestamp** command.

**Note**

The Harmonic NSG EQAM has a GUI screen that can display the clock.

The timestamps shown will not match exactly due to the 10 MHz rate of the clock, but the three timestamps should be close. If the timestamps are not close, verify the following:

- DTI wiring from the DTI server to the CMTS DTCC card
- DTI wiring from the DTI server to the EQAM
- Proper configuration of the three devices. The CMTS must be configured with the **cable clock dti** command.

The following example verifies the CMTS timing at the DTCC and MAC domain card:

```
Router> show cable clock dti client 1/1 | i stamp
```

```

Client timestamp                : 0x38683C64
Router> show contr ca5/0/0 | i stamp
Timestamp is from TCC card
Master Clock Timestamp = 0x3B0E1F89

RFGW-10# show cable clock | i stamp
Client timestamp                : 0x3C4F02FA

```

Troubleshooting EQAM Connectivity Issues of the M-CMTS

This section describes troubleshooting techniques for EQAM connectivity to the M-CMTS. It includes the following sections:

- [Verifying the Up State of an Active Gigabit Ethernet Port of a Wideband SPA, page 7-31](#)
- [Verifying the Up State of an Active Gigabit Ethernet Port of a Cisco uBR-MC3GX60V Line Card, page 7-32](#)
- [Verifying Layer 3 Connectivity to the EQAM, page 7-32](#)

Verifying the Up State of an Active Gigabit Ethernet Port of a Wideband SPA

The Gigabit Ethernet ports on a Wideband SPA are not considered standard user-configurable interfaces; However, they appear in the configuration (since Cisco IOS Release 12.2[33]SCC) because the DEPI protocol transmits and receives control packets by using this interface. The Wideband SPA is a controller with one active and one redundant Gigabit Ethernet port. The **show controller modular-cable** command displays information about the SPA, its Gigabit Ethernet active port, installed small form-factor pluggable (SFP) modules, and so on.

The following example provides sample **show controller modular-cable** output for the Wideband SPA located in slot 1, subslot 0, bay 0 of a Cisco uBR10012 router.

```
Router# show controller modular-cable 1/0/0 brief
```

```

SPA 0 is present
status LED: [green]
Host 12V is enabled and is okay.
Power has been enabled to the SPA.
SPA reports power enabled and okay.
SPA reports it is okay and is NOT held in reset.

```

```

Gigabit Ethernet Port Selected : Port 1
Receive Interface      : In Reset
Receive Interface      : Disabled
Transmit Interface     : Out of Reset
Transmit Interface     : Enabled
Primary Receive Clock  : Disabled
Backup Receive Clock   : Disabled
SFP [Port 0] : 1000BASE-SX Present
Tx Enabled , LOS Detected , TxFault Not Detected
Link Status [Port 0] : DOWN

SFP [Port 1] : 1000BASE-T Present
Tx Enabled , LOS Not Detected , TxFault Not Detected
Link Status [Port 1] : UP
...

```

In the preceding output, notice the following:

- The Gigabit Ethernet Port Selected field indicates the active Gigabit Ethernet port.
- For the active Gigabit Ethernet port, the SFP [Port 1] field indicates the type of SFP module that is present.
- For the active Gigabit Ethernet port, the Link Status [Port 1] field indicates whether the link is up.

The Cisco Wideband SPA transmits data in a unidirectional manner only and does not receive data from devices connected to its active Gigabit Ethernet port.

If the link for the active Gigabit Ethernet port is not up, check the following:

- The SFP module is correctly installed and matches the SFP module in the connected device.
- The cables to the Wideband SPA ports are correctly connected to a powered-on device.
- The cables to the Wideband SPA ports are not bent or damaged.
- A hardware failure has not occurred. For information, see the [“Performing Basic Power Troubleshooting on a Wideband SIP and Wideband SPA”](#) section on page 7-28.

Use the **show controller modular-cable** command with the **sfp** keyword to get more detailed information on the SFP modules installed in the Wideband SPA Gigabit Ethernet ports.

Verifying the Up State of an Active Gigabit Ethernet Port of a Cisco uBR-MC3GX60V Line Card

The Cisco uBR-MC3GX60V line card can have up to six SFPs for its three controllers. To check the presence and link status of the SFPs, use the **show controller modular-cable <slot/subslot/controller> sfp** command.

If the SFP is not present, the **show controller modular-cable <slot/subslot/controller> sfp** command output displays:

```
Router# show controller modular-cable 6/0/0 sfp
```

```
SFP in Port1 is NOT PRESENT
```

If the SFP is present, confirm if the physical port status is **Up** in the **show controller modular-cable <slot/subslot/controller> sfp** command output:

```
Router# show controller modular-cable 6/0/0 sfp
```

```
SFP in Port0 is Present.  Init status Success
      TX_DISABLE not set, LOS not detected, TX_FAULT not detected
LOS detection supported: no
Tx Fault detection supported: no
SFP Interrupt Counts:
      LOS:0, PRES:0, TX_FAULT:0
Link Status of the MV88E1146C DS Gige Phy Port: UP <<<— Physical port status is up
```

Verifying Layer 3 Connectivity to the EQAM

As of Cisco IOS Release 12.2(33)SCC, DEPI control plane functionality requiring bidirectional communication between the CMTS and the EQAM has been supported. This communication requires a Gigabit Ethernet interface visible to the IOS and hence visible with the **show ip interfaces brief** command.



Note

Only a very small fraction of the Gigabit Ethernet interface bandwidth is actually used by the DEPI protocol.

Both the Wideband SPA and the Cisco uBR-MC3GX60V line card have one Gigabit Ethernet interface per controller, therefore a Wideband SPA has one such interface and a Cisco uBR-MC3GX60V line card has three interfaces.

With an IP address is configured on the interface in a subnet, that includes the EQAM, the IP address of the EQAM is pingable. This provides a basic verification method of the bidirectional communication between the CMTS and the EQAM.

The following example shows the ping command output of an EQAM from the CMTS through the Gigabit Ethernet port of controller 0 of a Cisco uBR-MC3GX60V line card:

```
!
interface GigabitEthernet5/0/0
 ip address 10.31.136.215 255.255.255.0
 negotiation auto
 output-rate 100
end

router# show running-config | begin ontroll.*5/0/0

controller Modular-Cable 5/0/0
 rf-channel 0 cable downstream channel-id 1
 rf-channel 0 frequency 453000000 annex B modulation 256qam interleave 32
 rf-channel 0 ip-address 10.31.136.100 mac-address 0022.9084.4e3f depi-remote-id 101111

router# ping 10.31.136.100

Type escape sequence to abort.
Sending 5, 100-byte ICMP Echos to 10.31.136.100, timeout is 2 seconds:
!!!!
Success rate is 100 percent (5/5), round-trip min/avg/max = 1/9/12 ms
```

Troubleshooting Primary-Capable Channel DOCSIS Signalling

This section describes troubleshooting techniques for the Primary-capable Channel DOCSIS Signalling. It includes the following sections:

- [Verifying MAP, UCD, SYNCs for Primary-Capable Channels, page 7-33](#)
- [Verifying MDD Packet Transmit for DOCSIS 3.0 Operations, page 7-34](#)

Verifying MAP, UCD, SYNCs for Primary-Capable Channels

All primary-capable channels of a MAC domain transmit MAPs, UCDs, SYNCs packets downstream. In the case of DOCSIS 3.0 deployments, MDD is also transmitted.

For the MAC domain to transmit the packets, the associated modular-cable or integrated-cable interface must have UP status as shown in the **show ip interfaces** command output. If the interface is not up, verify the following:

1. The interface has been configured with the **cable rf-bandwidth-percent** command to have at least 1 percent of bandwidth.
2. The interface has been unshut.
3. The controller parameters are configured. This includes frequency, annex, modulation type, and interleaver.

4. The CGD configuration has been done in the MAC domain interface using the **downstream Modular-cable** or **downstream integrated-cable** command. Multiple configuration lines for primary channels may be used.
5. For modular-cable interfaces, the Gigabit Ethernet SFP is in the UP state (see [Verifying the Up State of an Active Gigabit Ethernet Port of a Cisco uBR-MC3GX60V Line Card](#), page 7-32)

When the modular-cable or integrated cable interface is up, verify that at least one upstream in the MAC domain is up with the **show interface <mac domain interface> upstream** command.

After the upstream is UP, verify if the MAPs, SYNCs, and UCDs are being transmitted. This can be done at 2 layers:

1. At the MAC domain layer, use the **show controller** command. Execute the **show controllers <MAC domain> upstream <upst ream number> | begin Map Counts** command and verify the output to determine if the Map Counts counter is incrementing.
2. At the hardware layer, use the **show controller <modular-cable | integrated-cable> <slot/subslot/controller> counters rf** command. Verify the output to determine if the MAP Pkts counter is incrementing. Verify if the SYNC Pkts counter is incrementing. Without any Layer 3 traffic, the Mbps rate for one upstream channel is approximately 0.9 to 1.0 Mbps. The Mbps rate for four upstreams is approximately 1.7 to 1.9 Mbps.

Verifying MDD Packet Transmit for DOCSIS 3.0 Operations

To support downstream and upstream bonding, the fiber node or fiber nodes in use by a MAC domain must be properly configured. The fiber node is used to calculate the correct downstream service groups and upstream service group IDs placed in the MDD packets. The fiber node configuration includes specifying the downstream channels and the upstream connector in use. The downstream channels must not have frequency or downstream channel ID conflicts.

The following example shows an invalid fiber node:

```
router# show running | begin fiber.*224

cable fiber-node 224
  downstream Modular-Cable 5/0/2 rf-channel 8-11 20-23
!
router# show cable fiber 224

-----
Fiber-Node 224
Channel(s)   : downstream Modular-Cable   5/0/2:   8-11 20-23
Channel ID(s): 57, 58, 59, 60, 69, 70, 71, 72
FN Config Status: Configured (status flags = 0x41)
MDD Status: Invalid
              No US Connector Configured
```

Use the **show controller <MAC domain> | begin MDD** command to check the number of MDD packets being transmitted. The following example shows that no MDD packets are transmitted:

```
router# show contr ca5/0/12 | beg MDD
MDDs           Primary           Non-Primary
-----
-----
```

Use the **show cable mac-domain <MAC domain> downstream-service-group** command to examine the downstream service groups for the MAC domain. The following example shows that there is no service group configured since the fiber node is invalid.

```
router# show cable mac-domain ca5/0/12 downstream-service-group

Cable   MD-DS-SG           RF
IF      Id      Resource   Chan   Primary Chan
C5/0/12
```

Completing the fiber node configuration with an upstream connector resolves the service group, which in turn allows the MAC domain to transmit MDD packets. The following example shows the above debug commands after a connector is configured in the fiber node causing it to be valid which in turn causes the service groups to be calculated and MDD packets to be transmitted and counted in the controller.

```
router# conf t
Enter configuration commands, one per line.  End with CNTL/Z.
router(config)#cable fiber 224
router(config-fiber-node)# upstream cable 5/0 connector 12
router(config-fiber-node)# end
Fiber node 224 is valid.
```

```
router# show run | begin fiber.*224
```

```
cable fiber-node 224
  downstream Modular-Cable 5/0/2 rf-channel 8-11 20-23
  upstream Cable 5/0 connector 12
```

```
router# show cable fiber 224
```

```
-----
Fiber-Node 224
Channel(s)   : downstream Modular-Cable   5/0/2:   8-11 20-23
Channel ID(s): 57, 58, 59, 60, 69, 70, 71, 72
upstream Cable 5/0: 12
  FN Config Status: Configured (status flags = 0x01)
  MDD Status: Valid
```

```
router# show cable mac-domain ca5/0/12 downstream-service-group
```

```
Cable   MD-DS-SG           RF
IF      Id      Resource   Chan   Primary Chan
C5/0/12 1      5/0/2     08-11  8 9 10 11
                               20-23
```

```
router# show controllers ca5/0/12 | begin MDD
```

```
-----
MDDs           Primary           Non-Primary
-----
5/0/2:8        36                0
5/0/2:9        36                0
5/0/2:10       36                0
5/0/2:11       36                0
5/0/2:20       0                 35
5/0/2:21       0                 35
5/0/2:22       0                 35
5/0/2:23       0                 35
-----
```

Troubleshooting Wideband SIP and Wideband SPAs

Verifying That a Wideband SPA Is Correctly Configured for SPA-to-EQAM Communications

If a Wideband SPA is unable to communicate with an edge QAM device, check that the RF channels configured with the **rf-channel** command match the values required by the edge QAM device. You can use the **show hw-module bay** command to see the values that have been configured for an RF channel:

```
Router# show hw-module bay 1/0/0 config rf-channel 0 verbose

SPA                               : Wideband-Cable 1/0/0
RF channel number                 : 0
Frequency                       : 699000000 Hz
Modulation                       : 64qam
Annex                             : B
IP address of next hop           : 192.168.200.30
MAC address of EQAM             : 000c.3033.2cbf
UDP port number                 : 49152
EQAM headroom                    : 0
```

Check that the following values are correct and match what is configured on the edge QAM device:

- Frequency—Center frequency used for this RF channel.
- IP address of next hop—IP address of the edge QAM device for this RF channel.
- MAC address—MAC address of the next-hop or edge QAM device for this RF channel.
- DEPI Remote ID—DEPI ID of the RF channel on the EQAM. The DEPI ID is seen with the non-verbose form of this command.
- UDP port—UDP port number for the QAM output port for this RF channel.

If any of the above values do not match what is present on the edge QAM device, the Wideband SPA will not be able to successfully communicate with that device.

On the Cisco uBR10012 router, RF channels are configured with the **rf-channel** command. The values on the edge QAM are device-specific and are typically configured when setting up the edge QAM device.

Verifying That a Wideband SPA Is Able to Communicate with the Edge QAM Device

To verify that a Wideband SPA that has been correctly configured for wideband operations is communicating with the edge QAM device, use the **show hw-module bay** command with the **counters** and **rf-channel** keywords. In the following example, only RF channels 0 to 3 on the Wideband SPA are transmitting MPEG packets.

```
Router# show hw-module bay 1/0/0 counters rf-channel

SPA      RF channel  MPEG packets tx      Sync Tx      MP Pkts Tx
1/0/0    0           109382989            18858822    90121503
1/0/0    1           109314434            18858822    90121203
1/0/0    2           0                    0            0
1/0/0    3           0                    0            0
1/0/0    4           0                    0            0
1/0/0    5           0                    0            0
1/0/0    6           0                    0            0
1/0/0    7           0                    0            0
1/0/0    8           0                    0            0
1/0/0    9           0                    0            0
1/0/0    10          0                    0            0
1/0/0    11          0                    0            0
```

1/0/0	12	0	0	0
1/0/0	13	0	0	0
1/0/0	14	0	0	0
1/0/0	15	0	0	0
1/0/0	16	0	0	0
1/0/0	17	0	0	0
1/0/0	18	0	0	0
1/0/0	19	0	0	0
1/0/0	20	0	0	0
1/0/0	21	0	0	0

Troubleshooting Wideband Channels

This section describes troubleshooting techniques for wideband channels. It includes the following sections:

- [Verifying That a Wideband Channel Is Up and Is Transmitting Packets, page 7-37](#)
- [Verifying That a Wideband Channel Is Configured Correctly, page 7-38](#)

For information about configuring wideband channels, see the *Cisco uBR10012 Universal Broadband Router SIP and SPA Software Configuration Guide*.

Verifying That a Wideband Channel Is Up and Is Transmitting Packets

To verify that a wideband channel is up and transmitting packets, use the **show interface wideband-cable** command and examine the first line of the output and the packets output field:

```
Router# show interface wideband-cable 1/0/0:1

Wideband-Cable1/0/0:1 is up, line protocol is up
  Hardware is Wideband CMTS Cable interface, address is 0012.001a.8897 (bia
0012.001a.8897)
  MTU 1500 bytes, BW 74730 Kbit, DLY 1000 usec,
    reliability 255/255, txload 1/255, rxload 1/255
  Encapsulation MCNS, loopback not set
  Keepalive set (10 sec)
  ARP type: ARPA, ARP Timeout 04:00:00
  Last input never, output 00:00:09, output hang never
  Last clearing of "show interface" counters never
  Input queue: 0/75/0/0 (size/max/drops/flushes); Total output drops: 0
  Queueing strategy: fifo
  Output queue: 0/40 (size/max)
  30 second input rate 0 bits/sec, 0 packets/sec
  30 second output rate 0 bits/sec, 0 packets/sec
    0 packets input, 0 bytes, 0 no buffer
    Received 0 broadcasts, 0 runts, 0 giants, 0 throttles
    0 input errors, 0 CRC, 0 frame, 0 overrun, 0 ignored, 0 abort
    24224 packets output, 1222002 bytes, 0 underruns
    0 output errors, 0 collisions, 0 interface resets
    0 output buffer failures, 0 output buffers swapped out
```

For information on what criteria are used to determine whether a wideband channel and its associated line protocol are up, see the [“show interface wideband-cable” section on page 7-14](#).

Verifying That a Wideband Channel Is Configured Correctly

To verify whether a wideband channel is configured correctly, use the **show hw-module bay** command with the **wideband-channel** keyword and the **association**, **config**, or **mapping** keywords. The following examples show the output for the **association** keyword:

```
Router# show hw-module bay 1/0/0 association wideband-channel 0
```

WB channel	BG ID	Bundle num	NB channel	NB chan ID	Reserved CIR	Avail CIR
Wideband-Cable1/0/0:0	24	123	Cable5/0/1	120	0	0

In the preceding output, the Bundle num field indicates the virtual bundle interface to which the wideband channel belongs. For a description of each field in the preceding output, see the [“show hw-module bay and show controller” section on page 7-16](#).

The wideband channel and the primary downstream channel (NB channel) must be members of the same virtual bundle interface. The CMTS running configuration file shows the virtual bundle (cable bundle) for the primary downstream channel (Cable5/0/1):

```
interface Cable5/0/1
  no ip address
  load-interval 30
  no cable packet-cache
  cable bundle 123
  cable downstream channel-id 120
  ...
```

The **downstream modular-cable rf-channel** command specifies the RF channels that are available for wideband channels on a fiber node. If a wideband channel attempts to use an RF channel that has not been made available for use on the fiber node, a misconfiguration error occurs. In this case, the **show hw-module bay** command displays the following error message:

```
Router# show hw-module bay 1/0/0 association wideband-channel
```

WB channel	BG ID	Bundle num	NB channel	NB chan ID	Reserved CIR	Avail CIR
Wideband-Cable1/0/0:0			RF channel mismatch with Fiber Node 1			

The following example shows the **show hw-module bay** command output for the **config** keyword:

```
Router# show hw-module bay 1/0/0 config wideband-channel
```

WB channel	BG ID	Bundle num	WB Host Slot/Subslot	Primary BG
Wideband-Cable1/0/0:0	24	123	5/0	Yes
Wideband-Cable1/0/0:1	25	123	5/0	Yes
Wideband-Cable1/0/0:2	26	123	5/0	Yes
Wideband-Cable1/0/0:3	27	123	5/0	Yes
Wideband-Cable1/0/0:4	28	123	5/0	Yes
Wideband-Cable1/0/0:5	29	123	5/0	Yes
Wideband-Cable1/0/0:6	30	123	5/0	Yes
Wideband-Cable1/0/0:7	31	123	5/0	Yes
Wideband-Cable1/0/0:8	32	0	5/0	Yes
Wideband-Cable1/0/0:9	33	0	5/0	Yes
Wideband-Cable1/0/0:10	34	0	5/0	Yes
Wideband-Cable1/0/0:11	35	0	5/0	Yes

In the preceding output, each wideband channel that is used should be configured as a member of a virtual bundle interface. Channels 8 through 11 are not members of a virtual bundle interface.

The following example shows the **show hw-module bay** command output for the **mapping** keyword:

```
Router# show hw-module bay 1/0/0 mapping wideband-channel
```

SPA	WB channel	RF channel	BW %
1/0/0	0	0	100
		1	100
1/0/0	1	2	100
		3	100
1/0/0	2	4	100
		5	100
1/0/0	3	6	100
		7	100
1/0/0	4	8	100
		9	100
1/0/0	5	10	100
		11	100
1/0/0	6	12	100
		13	100
1/0/0	7	14	100
		15	100
1/0/0	8	16	100
		17	100
1/0/0	9	18	100
		19	100
1/0/0	10	20	100
		21	100
1/0/0	11	22	100
		23	100

A channel-bonded wideband channel is associated with at least two RF channels depending on the wideband channel configuration. The **cable rf-channel** command associates an RF channel with a wideband channel. The bandwidth percent (BW %) of each RF channel used for the wideband channel is 100 percent by default, but is configurable with the **cable rf-channel** command.

Troubleshooting Wideband Cable Modems

This section describes troubleshooting techniques for wideband cable modems. It includes the following sections:

- [Pinging a Wideband Cable Modem, page 7-39](#)
- [Verifying That a Wideband-Capable Cable Modem Is Registered as a Wideband Modem, page 7-40](#)
- [Examining Wideband-Capable Modems That are Partial Online, page 7-41](#)
- [Verifying Other Information for Wideband Cable Modems, page 7-41](#)

Pinging a Wideband Cable Modem

To determine whether a wideband cable modem or any DOCSIS cable CPE device is reachable from the CMTS at the DOCSIS MAC layer, use the **ping docsis** command with either a MAC address or IP address:

```
Router# ping docsis 1.11.0.5
```

```
Queueing 5 MAC-layer station maintenance intervals, timeout is 25 msec:
!!!!
Success rate is 100 percent (5/5)
```

The **ping docsis** command uses 1/64—the bandwidth of IP ping—and works with cable modems that have not yet acquired an IP address. This allows you to ping cable modems that are unable to complete registration, that have internal bugs, or that are unresponsive due to a crash.

The **ping docsis** command with the **verbose** keyword includes a real-time view and plot of requested power adjustments, frequency, timing offset adjustments, and a measure of optimal headend reception power.

```
Router# ping docsis 1.11.0.5 verbose
```

```
Queueing 5 MAC-layer station maintenance intervals, timeout is 25 msec:
Reply from 0014.bfbe.3e3c: 46 ms, tadj=1, padj=0, fadj=34
Reply from 0014.bfbe.3e3c: 46 ms, tadj=0, padj=0, fadj=26
Reply from 0014.bfbe.3e3c: 50 ms, tadj=0, padj=0, fadj=29
Reply from 0014.bfbe.3e3c: 50 ms, tadj=1, padj=0, fadj=29
Reply from 0014.bfbe.3e3c: 50 ms, tadj=-1, padj=0, fadj=39
```

```
Success rate is 100 percent (5/5)
```

For more information on the **ping docsis** command, see the [Cisco Broadband Cable Command Reference Guide](#).

Verifying That a Wideband-Capable Cable Modem Is Registered as a Wideband Modem

To verify that a wideband-capable cable modem is registered as a wideband modem, use the **show cable modem** command. In the following example, the MAC address of the wideband cable modem is specified:

```
Router# show cable modem 0014.bfbe.3e70
```

MAC Address	IP Address	I/F	MAC State	Prim Sid	RxPwr (dBmv)	Timing Offset	Num CPE	BPI Enb
0014.bfbe.3e70	1.11.0.3	C5/0/1/U0	w-online(pt)	1	0.00	1231	0	Y

If a wideband-capable cable modem is registered as a wideband modem, the MAC State field will have one of the w-online values (wideband-online), such as w-online(pt) in the preceding example. For descriptions of the complete set of MAC state values, see the **show cable modem** command in the [Cisco Broadband Cable Command Reference Guide](#).

A wideband-capable modem may also register as a DOCSIS 2.0 modem (for example, if a wideband channel is not available). In this case, the MAC State field displayed by the **show cable modem** command will not have one of the w-online values.

To determine the set of wideband-capable cable modems that have registered as wideband modems on the CMTS, use the **show cable modem wideband** command:

```
Router# show cable modem wideband
```

MAC Address	IP Address	I/F	MAC State	Prim Sid	BG ID	DSID	MD-DS-SG
0014.bfbe.3e70	1.11.0.3	C5/0/1/U0	w-online(pt)	1	24	24	N/A
0014.bfbe.3e3c	1.11.0.4	C5/0/1/U0	w-online(pt)	2	24	24	N/A
0016.92fb.5742	1.11.0.6	C5/0/1/U0	w-online(pt)	3	24	256	1
0016.92fb.580e	1.11.0.7	C5/0/1/U0	w-online(pt)	4	24	264	1
0014.bfbe.3eaa	1.11.0.2	C6/0/1/U0	w-online(pt)	7	36	36	N/A
0016.92fb.57f8	1.11.0.5	C6/0/1/U0	w-online(pt)	8	36	298	1
0016.92fb.57f4	1.11.0.8	C6/0/1/U0	w-online(pt)	9	36	306	1

To determine the set of wideband-capable cable modems that have registered as DOCSIS 2.0 modems on the CMTS, use the **show cable modem wideband** command with the **registered-traditional-docsis** keyword.

Examining Wideband-Capable Modems That are Partial Online

A fault in one or more channels in the CMTS or cable plant may result in a wideband modem being partial online. DOCSIS 3.0 includes signaling based on the CM-STATUS message that enables modems to inform the CMTS about downstream failures. The CMTS will track and react upon these messages. The CMTS may disable an RF channel in a wideband channel, causing the modems to go into partial online mode, **p-online**. The **show cable modem partial** command can be used to view all modems in the p-online state.

To determine the cause of the partial online status, use the **show cable modem <address> wideband rcs-status** command for a modem in p-online mode. Failures reported by the modem will be counted categorically. For example:

```
Router # show cable modem 50.3.81.80 wideband rcs-status

CM : 0025.2e2d.74b8
RF : 5/0/2 8
  Status : UP
  FEC/QAM Failure : 0
  Dup FEC/QAM Failure : 0
  FEC/QAM Recovery : 0
  Dup FEC/QAM Recovery : 0
  MDD Failure : 0
  Dup MDD Failure : 0
  MDD Recovery : 0
  Dup MDD Recovery : 4
  Flaps : 0
  Flap Duration : 00:00
RF : 5/0/2 10
  Status : UP
  FEC/QAM Failure : 0
  Dup FEC/QAM Failure : 0
  FEC/QAM Recovery : 0
  Dup FEC/QAM Recovery : 0
  MDD Failure : 0
  Dup MDD Failure : 0
  MDD Recovery : 0
  Dup MDD Recovery : 0
  Flaps : 0
  Flap Duration : 00:00
```

The type of error reported can then be used to further troubleshoot the problem on the CMTS, the EQAM or the cable plant.

Verifying Other Information for Wideband Cable Modems

To verify other information related to wideband cable modems, use the **show** commands that display information relevant to all cable modems:

- **show cable modem access-group**—Displays information about the access group for each cable modem.
- **show cable modem classifiers**—Displays information about the classifiers used for each cable modem.
- **show cable modem cnr**—Displays carrier-to-noise ratio (CNR) information for cable modems that are using cable interface line cards with hardware spectrum-management capabilities.

- **show cable modem connectivity**—Displays connectivity information for each cable modem.
- **show cable modem counters**—Displays traffic counters for each cable modem.
- **show cable modem cpe**—Displays information about the CPE devices using each cable modem.
- **show cable modem errors**—Displays packet error information for each cable modem.
- **show cable modem flap**—Displays flap-list information for each cable modem.
- **show cable modem mac**—Displays MAC-layer information for each cable modem.
- **show cable modem maintenance**—Displays information about the Station Maintenance errors for each cable modem.
- **show cable modem offline**—Lists the offline cable modems.
- **show cable modem phy**—Displays the PHY layer information for each cable modem.
- **show cable modem qos**—Displays the quality of service (QoS) information for each cable modem.
- **show cable modem registered**—Lists the registered cable modems.
- **show cable modem remote-query**—Displays information collected by the remote-query feature.
- **show cable modem rogue**—Displays a list of cable modems that have been marked, locked, or rejected because they failed the dynamic shared-secret authentication checks.
- **show cable modem summary**—Displays summary information about the cable modems on each cable interface.
- **show cable modem unregistered**—Lists the unregistered cable modems.
- **show cable modem vendor**—Displays vendor names and identifies each cable modem.

For information on these commands, see the [Cisco Broadband Cable Command Reference Guide](#).

Troubleshooting Gigabit Ethernet Components

This section provides basic information for troubleshooting the Gigabit Ethernet components of the Cisco DOCSIS 3.0 Downstream Solution:

- [Troubleshooting the Cisco SIP-600, page 7-42](#)
- [Troubleshooting the Gigabit Ethernet SPAs, page 7-42](#)

Troubleshooting the Cisco SIP-600

The troubleshooting techniques adopted for the Cisco SIP-600 is similar to what is used for a Cisco Wideband SIP. For more information, see the chapter “Troubleshooting the SIPs” in the *Cisco uBR10012 Universal Broadband Router SIP and SPA Software Configuration Guide*.

Troubleshooting the Gigabit Ethernet SPAs

For detailed troubleshooting information on Gigabit Ethernet SPAs, see the chapter “Troubleshooting Gigabit Ethernet SPAs” in the *Cisco uBR10012 Universal Broadband Router SIP and SPA Software Configuration Guide*.



Cisco DOCSIS 3.0 Downstream Solution, Component Compatibility Matrix

Table 1-1 and Table 1-2 summarizes the compatibility of Cisco DOCSIS 3.0 Downstream Solution components with the Cisco IOS software functionality supported in the following major releases of the solution:

- Cisco DOCSIS 3.0 Downstream Solution (Cisco IOS Release 12.2(33)SCH and later releases)

Yes—Indicates that the component is compatible with the solution release and provides full support for the release features and functionality.

No—Indicates that the component is not compatible with the solution release and does not provide full support for the release features and functionality. See the Notes column for more information.

Table 1-1 indicates the matrix for unicast with secondary Wideband interface with DOCSIS Baseline Privacy Interface (BPI) feature:

Table 1-1 *Compatibility Matrix for Primary Downstreams and Wideband Interfaces for Unicast on Secondary Wideband Interface with BPI Configuration*

Primary Downstream Interface and Wideband Interface	Cisco UBR-MC20X20V ¹	Cisco UBR-MC3GX60V ²	Cisco Wideband SPA and Cisco UBR-MC20X20V MAC Domain Interface	Cisco Wideband SPA and Cisco UBR-MC3GX60V MAC Domain Interface
Secondary Cisco Wideband Interface				
Cisco UBR-MC20X20V	Yes	Yes	Yes	Yes
Cisco UBR-MC3GX60V	Yes	Yes	Yes	Yes
Cisco Wideband SPA	Yes	Yes	No	No

1. The Cisco UBR-MC20X20V cable interface line card has three variants: Cisco UBR-MC20X20V-0D, Cisco UBR-MC20X20V-5D, and Cisco UBR-MC20X20V-20D. The Cisco UBR-MC20X20V-0D line card supports 20 upstreams and zero (no) downstreams. The Cisco UBR-MC20X20V-5D line card supports 20 upstreams and 5 downstreams, and the Cisco UBR-MC20X20V-20D line card supports 20 upstreams and 20 downstreams.
2. The Cisco uBR-MC3GX60V line card is supported with PRE4 and PRE5.

Table 1-2 indicates the matrix for static multicast on remote Wideband interface without BPI configuration:

Table 1-2 Compatibility Matrix for Primary Downstreams and Wideband Interfaces for Static Multicast on Remote Wideband Interface without BPI (Unencrypted) Configuration

Primary Downstream Interface and Wideband Interface	Cisco UBR-MC20X20V ¹	Cisco UBR-MC3GX60V ²	Cisco Wideband SPA and Cisco UBR-MC20X20V MAC Domain Interface	Cisco Wideband SPA and Cisco UBR-MC3GX60V MAC Domain Interface
Remote Wideband Interface				
Cisco UBR-MC20X20V	Yes	Yes	Yes	Yes
Cisco UBR-MC3GX60V	Yes	Yes	Yes	Yes
Cisco Wideband SPA	Yes	Yes	Yes	Yes

1. The Cisco UBR-MC20X20V cable interface line card has three variants: Cisco UBR-MC20X20V-0D, Cisco UBR-MC20X20V-5D, and Cisco UBR-MC20X20V-20D. The Cisco UBR-MC20X20V-0D line card supports 20 upstreams and zero (no) downstreams. The Cisco UBR-MC20X20V-5D line card supports 20 upstreams and 5 downstreams, and the Cisco UBR-MC20X20V-20D line card supports 20 upstreams and 20 downstreams.
2. The Cisco uBR-MC3GX60V line card is supported with PRE4 and PRE5.

Table 1-3 summarizes the compatibility of Cisco DOCSIS 3.0 Downstream Solution components with the Cisco IOS software functionality supported in the following major releases of the solution:

- Cisco Wideband Cable Solution, Release 1.0 (Cisco IOS Release 12.3[21]BC and Cisco IOS Release 12.3[21a]BC3)
- Cisco DOCSIS 3.0 Downstream Solution (Cisco IOS Release 12.3[23]BC and Cisco IOS Release 12.2[33]SCB (and later releases))

In Table 1-3, the following applies:

Yes—Indicates that the component is compatible with the solution release and provides full support for the release features and functionality.

No—Indicates that the component is not compatible with the solution release and does not provide full support for the release features and functionality. See the Notes column for more information.

Table 1-3 Component-compatibility

Solution Component	Cisco Cable Wideband Solution, Cisco IOS Releases 12.3(21)BC & 12.3(21a)BC3	Cisco DOCSIS 3.0 Downstream Solution, Cisco IOS Release 12.3(23)BC	Cisco DOCSIS 3.0 Downstream Solution, Cisco IOS Release 12.2(33)SCB and later releases	Notes
Performance Routing Engine 2 (PRE2)	Yes	Yes	Yes	
Performance Routing Engine 4 (PRE4)	No	No	Yes	Required for the 1-port 10 Gigabit Ethernet SPA
Performance Routing Engine 5 (PRE5)	No	No	Yes	Introduced in Cisco IOS Release 12.2(33)SCH
Cisco UBR-MC20X20V cable line card	No	No	Yes	Introduced in Cisco IOS Release 12.2(33)SCC
Cisco uBR-MC3GX60V line card	No	No	Yes	Introduced in Cisco IOS Release 12.2(33)SCE
Cisco Wideband SIP	Yes	Yes	Yes	
Cisco Wideband SPA	Yes	Yes	Yes	
Cisco 3 Gbps Wideband Shared Port Adapter	Yes	Yes	Yes	Introduced in Cisco IOS Release 12.2(33)SCH
Cisco 6 Gbps Wideband Shared Port Adapter	Yes	Yes	Yes	Introduced in Cisco IOS Release 12.2(33)SCI
Cisco 10000 SPA Interface Processor-600	No	No	Yes	The Cisco Wideband SIP and the Cisco SIP-600 cannot coexist on a Cisco uBR10012 router
Cisco 5-port Gigabit Ethernet SPA	No	No	Yes	
Cisco 1-port 10 Gigabit Ethernet SPA	No	No	Yes	

Table 1-3 Component-compatibility (continued)

Solution Component	Cisco Cable Wideband Solution, Cisco IOS Releases 12.3(21)BC & 12.3(21a)BC3	Cisco DOCSIS 3.0 Downstream Solution, Cisco IOS Release 12.3(23)BC	Cisco DOCSIS 3.0 Downstream Solution, Cisco IOS Release 12.2(33)SCB and later releases	Notes
Timing, Communication, and Control Plus card (TCC+)	Yes	No	Yes	Will work with Cisco IOS Release 12.3(23)BC, but does not support a DOCSIS timing server.
DOCSIS Timing and Control Card (DTCC)	Yes	Yes	Yes	
Linksys WCM300-NA, Linksys JP, and WCM300-EURO modems	Yes	Yes	No	
Scientific Atlanta DPC2505 and EPC2505 modems	Yes	Yes	Yes	
Scientific Atlanta DPC3000 and DPC3010 modems	Yes	Yes	Yes	
Scientific Atlanta Continuum DVP XDQA24 EQAM device	Yes	Yes	Yes	
Harmonic NSG 9116 EQAM device	Yes	No	Yes	
Harmonic NSG 9000 EQAM device	Yes	Yes	Yes	
Vecima Networks VistaLynx VL1000 EQAM device	Yes	No	Yes	
Cisco RF Gateway 1	Yes	Yes	Yes	
Cisco RF Gateway 10	Yes	Yes	Yes	