



Cisco Remote-PHY Compact Shelf Hardware Installation Guide

Americas Headquarters

Cisco Systems, Inc.
170 West Tasman Drive
San Jose, CA 95134-1706
USA
<http://www.cisco.com>
Tel: 408 526-4000
800 553-NETS (6387)
Fax: 408 527-0883



CHAPTER 1

Cisco Remote-PHY Solution Overview

- [Introduction, on page 1](#)
- [Benefits, on page 2](#)
- [Architecture Overview, on page 2](#)
- [Cisco Cable Modem Termination System, on page 3](#)
- [Cisco Remote-PHY Compact Shelf, on page 3](#)
- [Cisco CCAP RF Line Card for R-PHY, on page 10](#)
- [Cisco Digital Physical Interface Card, on page 10](#)

Introduction

Driven by market evolution towards triple-play services, cable operators in emerging markets are seeking standardized and digital fiber-based solutions for economical and future proof access technologies. Much of the demand is driven by the need to provide higher bandwidth packet transport for Internet connectivity, video and voice services.

Data Over Cable Systems Interface Standard (DOCSIS®) is a standardized technology for services over cable and thus has strong interoperability between system providers. It also provides robust Quality of Service (QoS) methods, ensuring packet delivery during periods of network congestion. Traditionally, DOCSIS runs on linear fiber (or HFC) to provide service and is not naturally applicable for digital fiber. Cisco has bridged the gap by introducing a new access technology called the Remote-PHY.

Existing Architecture

In the emerging markets, most triple-play consumers live in multi-tenant buildings (referred to as Multi Dwelling Units or MDU) with the number of residents usually being less than 500 residents per building or cluster. These buildings are typically served by fiber with one of several “final 100 meter” technologies installed in the buildings. These technologies include fiber, twisted pair, Ethernet, and coaxial. Cable operators have access to the cable in the building and use this cable for their services. Several technologies exist for enabling two-way services over cable. These include a number of proprietary and vendor-specific methods. However, a standards-based approach to using cable is typically preferred by operators, since this ensures vendor interoperability.

Need for the Cisco Remote-PHY Solution

DOCSIS and EuroDOCSIS are standards that define two-way operation over a cable network. DOCSIS provides the necessary Quality of Service (QoS) tools for ensuring voice call connectivity during periods of

network congestion that are anticipated in triple-play networks. DOCSIS is a robust and mature technology for voice, video, and IP video services.

The Cisco Remote-PHY solution leverages existing IP technologies and deploys DOCSIS in remote field over digital fiber to enable two-way services over cable.

Benefits

The Cisco Remote-PHY solution provides a cost-effective digital fiber-based DOCSIS solution that uses Metro Ethernet (MetroE) as the transmission network between the Cisco CMTS and the cable modem.

- Reduced investment cost including capital and operational expenditure.
- Reduced CMTS hardware complexity.
- No restriction on Converged Interconnect Network (CIN) network.
- Futureproof architecture. Easy to migrate as the hardware and control functions are on separate layers.
- End-to-end QoS assurance provided by DOCSIS.
- Support for all DOCSIS services.
- Support for existing DOCSIS network provisioning system.
- High access bandwidth.
- With deep fiber, the optical noise contribution to SNR is eliminated. As a result, the remote QAM modulator runs at higher orders of modulation as compared to a centralized QAM modulator.

Architecture Overview

Modular Headend Architecture version 2 (MHA v2) is a set of specifications for the Cisco Remote-PHY solution. It uses digital fiber compatible baseband networking technology to drive the fiber portion of the HFC plant. The coaxial portion of the plant remains the same. The upstream and downstream PHY are located on the remote side and acts as the remote PHY system. The Cisco Remote-PHY Compact Shelf acts as the remote PHY system. It connects the digital fiber and the coaxial portions of the plant together. The remote PHY system resides near or in buildings and has both RFI and Gigabit Ethernet interfaces. It provides layer 1 PHY (downstream and upstream PHY) functionality, layer 2 MAC functionality, and layer 3 tunneling and forwarding support. The CMTS remains unchanged with the exception of the upstream and downstream PHY being moved to the remote PHY system. The Cisco RF line card installed in the Cisco CMTS does not have the RFI interfaces for downstream and upstream, instead, it has Gigabit Ethernet interfaces for both downstream and upstream.

Protocols that form this architecture include:

- Downstream External PHY Interface Decapsulation—Downstream External PHY Interface (DEPI) is a L2TPv3-based protocol defined for downstream DOCSIS MAC management and data packets decapsulation. It is unidirectional, that is, from CMTS to remote PHY system.

DEPI supports:

- IP/User Datagram Protocol (UDP)

- DOCSIS MPT Mode (D-MPT)/Packet Streaming Protocol (PSP)
- Upstream External PHY Interface Encapsulation—Upstream External PHY Interface (UEPI) is a L2TPv3-based protocol defined for upstream DOCSIS MAC management and data packets encapsulation. It is unidirectional, that is, from remote PHY system to CMTS.

UEPI:

- Does not support UDP
 - Supports PSP mode only
 - Supports multiple pseudowires for RNG/BW-REQ/SPECTRUM-MGMT/MAP
- GCP—Generic Control Protocol, sets up a control plane tunnel over a generic transport protocol such as TCP or UDP. GCP is used to program the remote PHY system upstream and downstream parameters from the CMTS. It is also used to control the remote PHY system.

GCP supports:

- TCP/UDP
- DS/US PHY configuration and CMC provisioning/configuration
- Register mode and type, length, value (TLV) mode
- Notification

Cisco Cable Modem Termination System

The Cisco cBR converged broadband router acts as the Cable Modem Termination System (CMTS) core for the Cisco Remote-PHY architecture.

Following are its functions:

- Assigns downstream and upstream channels of the Cisco RF line card to the Cisco Remote-PHY Compact Shelf.
- Performs MAC classification, forwarding, and management functions.
- Handles the Cisco Remote-PHY Compact Shelf configuration and management.

For more information on the Cisco CMTS, go to [Cisco cBR Series Converged Broadband Routers](#) page.

Cisco Remote-PHY Compact Shelf

Below are some of the features of the Cisco Remote-PHY Compact Shelf:

- Full spectrum DOCSIS 3.0 support
- Full spectrum DOCSIS 3.1 support
- Converged broadcast, narrowcast, and VOD video support

- Out of Band (OOB) signaling support
- Dual 10GBE SFP+ backhaul connectivity
- CCAP support
- Support of optical overlay architectures

Figure 1: Cisco Remote-PHY Compact Shelf

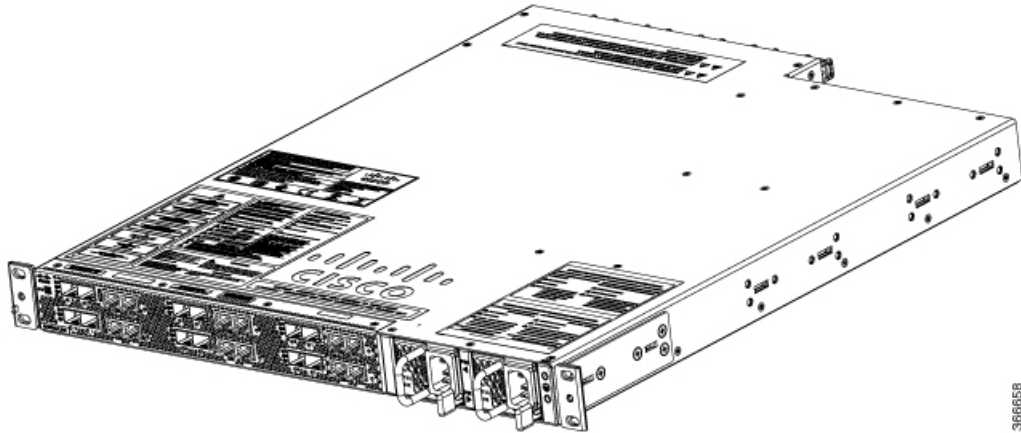

For the product described in this document both downstream and upstream PHY functionality is located in a shelf at the Headend, Hub or VHUB (Virtual Hub). The output of the Cisco Remote-PHY Compact Shelf feeds a conventional HFC network with optical nodes and RF amplifier cascades. The Cisco Remote-PHY Compact Shelf is intended to interact with the cBR-8 router, via a digital physical interface card (D-PIC) and the Cisco CCAP RF Line Card for Remote-PHY.

There are two models for Cisco Remote-PHY Compact Shelf: Cisco Remote-PHY Compact Shelf 6 x 12 and Cisco Remote-PHY Compact Shelf 3 x 6. They have the same functions, the only difference is the number of RPD modules integrated in the device. Cisco Remote-PHY Compact Shelf 6 x 12 has 6 RPD modules, Cisco Remote-PHY Compact Shelf 3 x 6 has 3 RPD modules.

Front View

The following figure shows the front of the Cisco Remote-PHY Compact Shelf.

Figure 2: Cisco Remote-PHY Compact Shelf 6 x 12 Front View

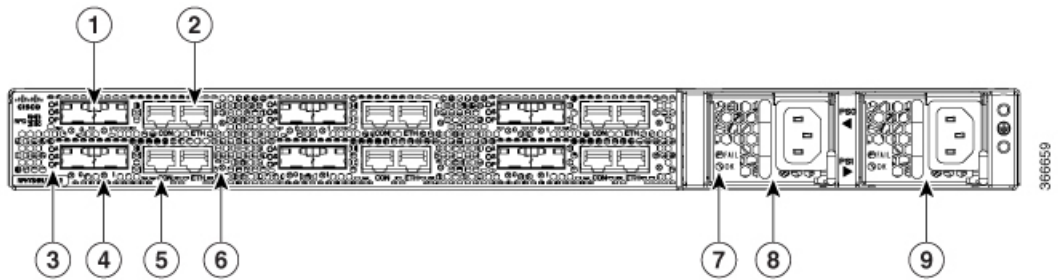
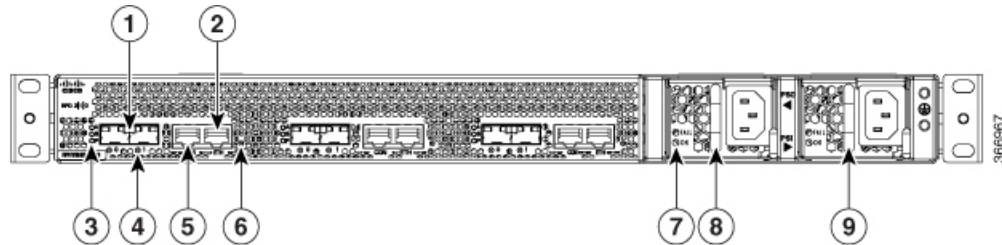

Figure 3: Cisco Remote-PHY Compact Shelf 3 x 6 Front View



1	0, 1 - 10GE SFP+ port	6	Management port LED
2	ETH - RJ-45 management port	7	Power supply LED
3	A, S, P - Alarm, Status, Power LED	8	PS0 – Power supply 0
4	SFP LED	9	PS1 – Power supply 1
5	CON - RJ-45/RS-232 compatible console port		

The following table shows the meaning of LED on the front panel of the Cisco Remote-PHY Compact Shelf.

Table 1: Cisco Remote-PHY Compact Shelf LEDs

No.	LED Label	Description	Behavior	Meaning
1	S	Status	Blinking	Normal.
2	P	Power	Green	Power on.
3	A	Alarm	Yellow	RPD module error, check the console logging.
4	SFP 0/1 LED	Link status	Green	Link is up.
5	ETH LED	Link status	Green	Link is up.

Rear View

The following figure shows the rear of the Cisco Remote-PHY Compact Shelf.

Figure 4: Cisco Remote-PHY Compact Shelf 6 x 12 Rear View

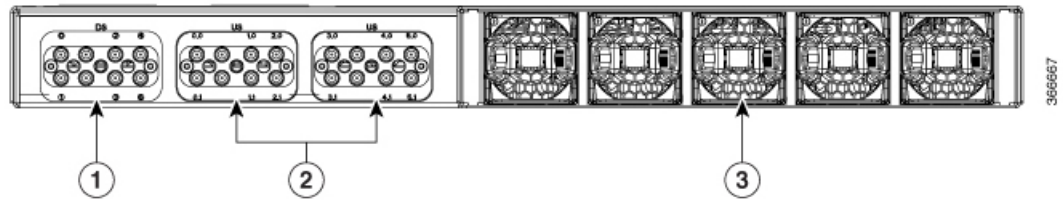
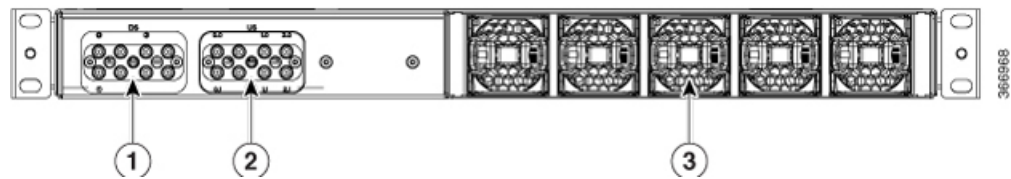

Figure 5: Cisco Remote-PHY Compact Shelf 3 x 6 Rear View



1	Downstream port cluster	3	Fans
2	Upstream port cluster		

The chassis has a front-to-rear airflow. Five internal fans draw cooling air into the chassis and across internal components to maintain an acceptable operating temperature. The fans are numbered from 1 to 5, right to left.

Two power supplies (AC or DC) are accessed from the front of the device and are hot-swappable.

Power Supplies

The Cisco Remote-PHY Compact Shelf support AC or DC power supply options. The modular chassis configurations support the installation of two power supplies for redundancy, the current sharing feature is supported when two power supplies are installed in the system. When an external power supply fails or is removed, the other power supply provides power requirements for the chassis. This allows you to hot-swap the power supply without impacting the functionality of the device.



Caution

Cisco Remote-PHY Compact Shelf can support two AC or two DC power supplies. Do not install mixed AC and DC power supply units in the same chassis.

The following table lists the power supplies that you can order:

Part Number	Power Supply
341-100761-01	Cisco Remote-PHY Compact Shelf DC Power Supply
341-100760-01	Cisco Remote-PHY Compact Shelf AC Power Supply

**Caution**

The chassis has a front-to-rear airflow. All of the power supplies and fan modules in the chassis must use the same airflow direction or an error will occur with possible overheating and shut down of the Cisco Remote-PHY Compact Shelf. If you power up the Cisco Remote-PHY Compact Shelf with more than one airflow direction, you must power down the Cisco Remote-PHY Compact Shelf and replace the modules with the wrong airflow direction before powering up the Cisco Remote-PHY Compact Shelf.

AC Power Supply

The AC power supply input connector is IEC60320 C16, equipped with standard input AC power cord. The power supply has a handle to be used for insertion and extraction.

The following figure shows the Cisco Remote-PHY Compact Shelf AC power supply.

Figure 6: AC Power Supply Used in the Cisco Remote-PHY Compact Shelf

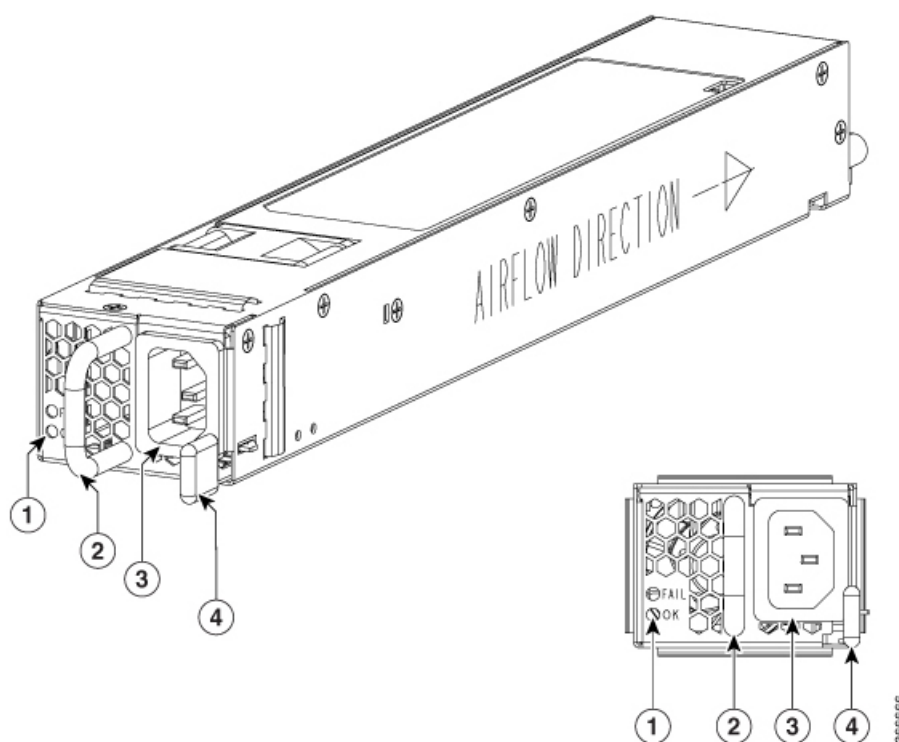

1	FAIL and OK LEDs	3	AC power connector
2	Handle	4	Retaining latch

DC Power Supply

The DC power supply input connector is a two-wire connector with connection polarity from left to right (when facing the unit) of positive (+) negative (-).

The power supply has a handle to be used for insertion and extraction. The module must be supported with one hand when installing into or removing from Cisco Remote-PHY Compact Shelf.

The following figure shows the Cisco Remote-PHY Compact Shelf DC power supply.

Figure 7: DC Power Supply Used in the Cisco Remote-PHY Compact Shelf

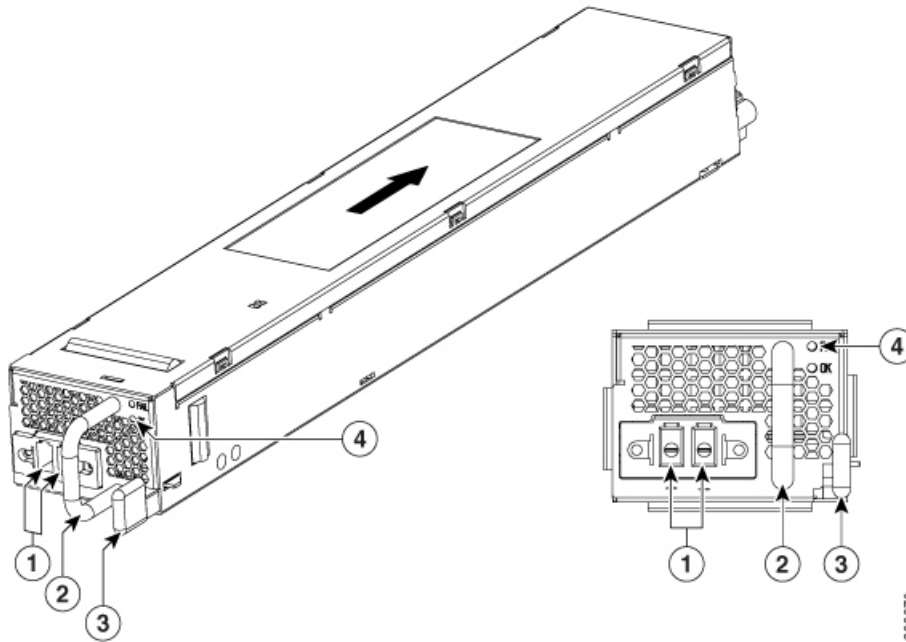

1	DC power connections	3	Retaining latch
2	Handle	4	FAIL and OK LEDs

Power Supply LEDs

The following table describes the power supply LEDs.

Table 2: AC and DC Power Supply LEDs

Power Supply Condition	Green (OK) LED Status	Amber (FAIL) LED Status
No AC power to all power supplies	OFF	OFF
Power Supply Failure (includes over voltage, over current, over temperature and fan failure)	OFF	ON
Power Supply Warning events where the power supply continues to operate (high temperature, high power and slow fan)	OFF	1Hz Blinking
AC Present/3.3VSB on (PSU OFF)	1Hz Blinking	OFF
Power Supply ON and OK	ON	OFF

Power Supply Fans

The fans in the power supply module are used for cooling the power supply module itself while system-level cooling is provided by fans within the chassis. The power supplies do not depend on the system-level fans for cooling. Fan failure is determined by fan-rotation sensors.



Note The fans in the power supply modules will run as soon as the power supply is plugged in.

Power Cords

The following table lists the supported power cords.

Power Cord Item Number	Description
CAB-AC-ARG	Power Cord - Argentina, 10A, 250V, 2500mm, -40°C to +85°C
CAB-AC-AUS	Power Cord - Australia, 10A, 250V, 2500mm, -40°C to +85°C
CAB-AC-BRA	Power Cord - Brazil, 10A, 250V, 2500mm, -40°C to +85°C
CAB-AC-CHI	Power Cord - China, 10A, 250V, 2500mm, -40°C to +85°C
CAB-AC-EUR	Power Cord - Europe, 16/10A, 250V, 2500mm, -40°C to +85°C
CAB-AC-IND	Power Cord - India, 16/10A, 250V, 2500mm, -40°C to +85°C
CAB-AC-ISR	Power Cord - Israel, 16/10A, 250V, 2500mm, -40°C to +85°C
CAB-AC-ITL	Power Cord - Italy, 10A, 250V, 2500mm, -40°C to +85°C
CAB-AC-KOR	Power Cord - Korea, 16/10A, 125V, 2500mm, -40°C to +85°C
CAB-AC-SUI	Power Cord - Swiss, 10A, 250V, 2500mm, -40°C to +85°C
CAB-AC-TAI	Power Cord - Taiwan, 15/10A, 125V, 2500mm, -40°C to +85°C
CAB-AC-UK	Power Cord - UK, 13/10A, 250V, 2500mm, -40°C to +85°C
CAB-AC-US	Power Cord - US, 15A, 125V, 2500mm, -40°C to +85°C
PWR-CAB-AC-JPN	Power Cord for AC V2 Power Module (Japan)

Fan Tray

The fan tray is a field replaceable unit which can be replaced on site when required.

Follow the steps below to replace a fan tray:

1. Pull out the fan tray for about 0.5 inch.
2. Wait for the fan blades are totally stopped.

**Danger**

Rotating fan blades can cause serious injury during fan tray removal or replacement.

3. Pull out the fan tray completely and replace it with a new fan tray.

Cisco CCAP RF Line Card for R-PHY

The Cisco CCAP RF line card for remote PHY architecture is available in two flavours:

- CBR-LC-8D31-16U30—This RF line card with the downstream and upstream PHY modules can be connected with the Cisco Remote-PHY Compact Shelf by configuring it using the **card cBR-CCAP-LC-40G r-phy** command.
- CBR-CCAP-LC-40G-R—This RF line card with no downstream and upstream PHY modules can be connected with the Cisco Remote-PHY Compact Shelf.

Cisco Digital Physical Interface Card

The Cisco Digital Physical Interface Card (DPIC) transmits and receives RF signals between the subscriber and headend over the hybrid fiber-coaxial (HFC) system and is DOCSIS-compliant. This interface card is designed specifically for the Cisco cBR router and conforms to the Integrated CMTS (I-CMTS) architecture. The PID is cBR-DPIC-8X10G.

The DPIC is installed in the CMTS and connected to the Cisco Remote-PHY Compact Shelf via the Metro Ethernet. It supports both downstream and upstream traffic. Both the downstream and upstream traffic share the same ports.

Table 3: Physical Specifications of the DPIC

Unit	Dimensions
Width	10.96 in (27.8cm)
Height	1.43 in (3.6cm)
Depth	7.32 in (18.6cm) with handle
Weight	2.943lb (1.335kg)

The DPIC supports:

- Eight ten gigabit ethernet SFP+ interfaces
- 80 gigabit non-blocking switching architecture with 40+40 protection scheme

- 40 gigabit DOCSIS traffic bandwidth when connected with the Cisco CBR-CCAP-LC-40G-R line card
- Cisco SFP-10G-SR-S/Cisco SFP-10G-LR-S/Cisco SFP-10G-ZR-S/Cisco SFP-10G-ER-S optic modules
- MACSec and 1588 TC

The faceplate of the Cisco DPIC has the following:

- Optic Cable Clip—Helps route and manage the optic cables.
- 8 x SFP+ ports—Used as 8 x 10GE lanes for DOCSIS traffic to the Cisco RPDs.
- 10GE Link Status LED—Indicates the status of the 10GE link.
- Status LED—Indicates the status of the Cisco DPIC.
- Replace LED—Indicates the Cisco DPIC must be replaced.

Onboard Failure Logging

The Onboard Failure Logging (OBFL) feature enables the storage and collection of critical failure information in the nonvolatile memory of a Field Replaceable Unit (FRU), like a route processor (RP) or line card. The data stored through OBFL assists in understanding and debugging the field failures upon Return Material Authorization (RMA) of a RP or line card at repair and failure analysis sites. OBFL records operating temperatures, voltages, hardware uptime, and any other important events that assist board diagnosis in case of hardware failures.

For more information about the feature, see [Onboard Failure Logging](#).



Note The sample output provided in the [Onboard Failure Logging](#) guide may vary slightly for the Cisco CMTS routers.



CHAPTER 2

Cisco Remote-PHY Solution Deployment

- [Design Considerations, on page 13](#)
- [Network Architecture, on page 13](#)
- [Network Topologies, on page 14](#)
- [Network Cables, on page 15](#)

Design Considerations

This section helps you prepare for deploying the Cisco Remote-PHY solution.

Prerequisites

- Ensure that a digital optical network is deployed between the Cisco Remote-PHY Compact Shelf and Cisco CMTS. The supported digital optical network is Metro Ethernet.
- Ensure that the data path is guaranteed between the Cisco CMTS and the Cisco Remote-PHY Compact Shelf.
- Reserve sufficient bandwidth for the DOCSIS traffic.
- Network must support IPv4 multicast forwarding.
- Ensure that the maximum latency is as low as possible.
- Based on the input type in the network, deploy or use the appropriate type of R-PHY device.

Network Architecture

The Cisco Remote-PHY solution supports the *Single Controller Sharing* architecture. In this architecture, multiple Cisco Remote-PHY Compact Shelves share the downstream and upstream channels of a Cisco RF line card in a Cisco cBR chassis.

Figure 8: Single Controller Sharing Architecture

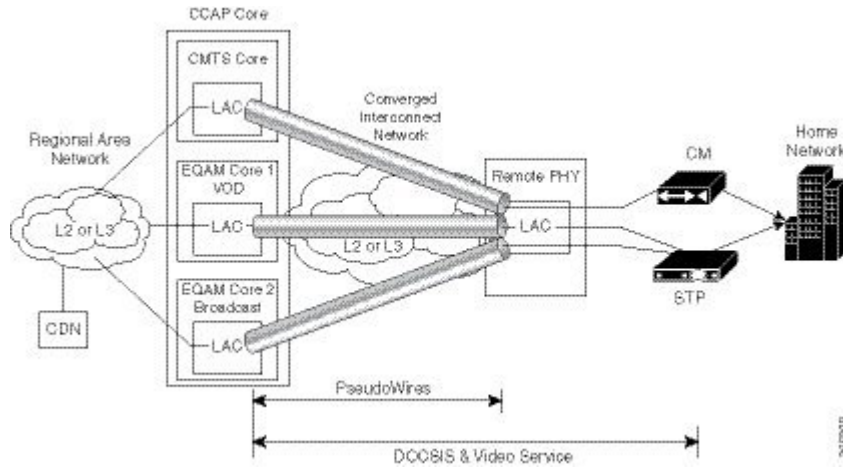

Network Topologies

The Cisco Remote-PHY solution supports Ethernet Based Networking topology.

Figure 9: Standard Deployment

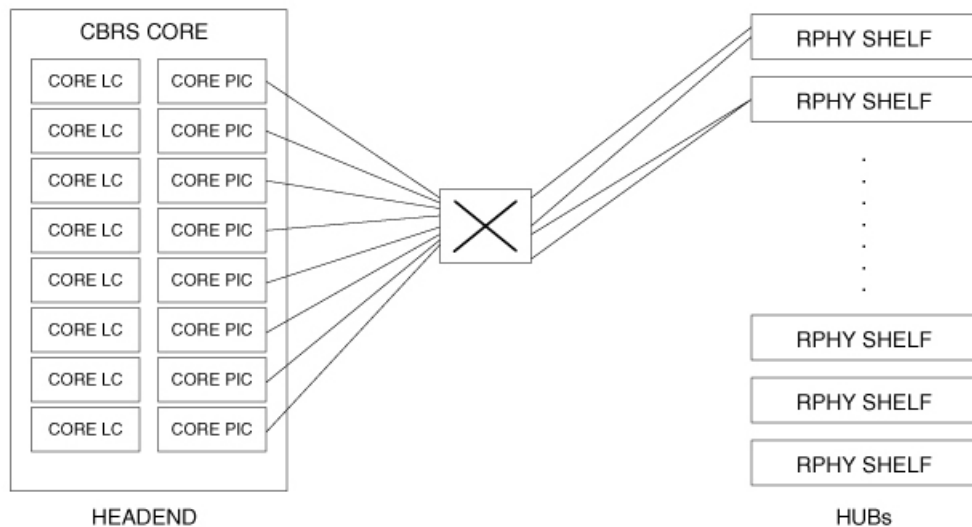

Network Cables

Table 4: Cable Types Supported for the Cisco Remote-PHY Solution

Originating Device	Target Device	Cable Type	Connector Type
CMTS (Ten Gigabit Ethernet SFP+ module on the Cisco CCAP line card)	Switch	Ethernet cables	RJ-45 connector
		Copper cables	RJ-45 connector
		Optical fiber	LC Fiber-Optic connector
Switch	Cisco Remote-PHY Compact Shelf	Optical fiber	LC Fiber-Optic connector



CHAPTER 3

Preparing for the Installation

Before you install the Cisco Remote-PHY solution, consider the following:

- Power and cabling requirements that must be in place at your installation sites
- Equipment required to install the Cisco Remote-PHY solution
- Environmental conditions your installation site must meet to maintain normal operation



Note Do not unpack the equipment until you are ready to install it. Keep the equipment in the shipping container to prevent accidental damage until you determine an installation site.

- [Prerequisites and Preparation, on page 17](#)
- [Safety Guidelines, on page 18](#)
- [General Safety Warnings, on page 19](#)
- [Site Planning, on page 20](#)
- [Preventing Electrostatic Discharge Damage, on page 30](#)
- [Electrical Safety, on page 31](#)
- [Chassis-Lifting Guidelines, on page 32](#)
- [Tools and Equipment, on page 32](#)
- [Unpacking and Verifying Shipping Contents, on page 33](#)
- [Installation Checklist, on page 34](#)

Prerequisites and Preparation

Before you perform the procedures in this guide, we recommend that you:

- Read the safety guidelines in the next section and review the electrical safety and ESD-prevention guidelines in this guide.
- Ensure that you have all of the necessary tools and equipment.
- Ensure that the power and cabling requirements are in place at your installation site.
- Ensure that the equipment required to install the device is available.
- Ensure that your installation site meets the environmental conditions to maintain normal operation.

Before installing the device, you must consider power and cabling requirements that must be in place at your installation site, special equipment for installing the device, and the environmental conditions your installation site must meet to maintain normal operation.

The shipping package for the device is engineered to reduce the chances of product damage associated with routine material handling experienced during shipment:

- Device should always be transported or stored in its shipping package in the upright position.
- Keep the device in the shipping container until you have determined the installation site.



Note Inspect all items for shipping damage. If an item appears damaged, contact a Cisco customer service representative immediately.

Site Planning Checklist

Use the following checklist to perform and account for all the site-planning tasks described in this chapter:

- The site air conditioning system can compensate for the heat dissipation of the device.
- Electrical service to the site complies with the requirements.
- The electrical circuit servicing the device complies with the requirements.
- Consideration has been given to console port wiring and limitations of the cabling involved, according to TIA/EIA-232F.
- The Ethernet cabling distances are within limitations.
- The equipment rack in which you plan to install the chassis complies with requirements. Careful consideration has been given to safety, ease of maintenance, and proper airflow in selecting the location of the rack.

Safety Guidelines

Before you begin the installation or replacement procedure, review the safety guidelines in this section to avoid injuring yourself or damaging the equipment.



Note This section contains guidelines, and do not include every potentially hazardous situation. When you install the device, always use common sense and caution.

Safety Warnings

Safety warnings appear throughout this publication in procedures that, if performed incorrectly, might harm you. A warning symbol precedes each warning statement.

Before you install, configure, or perform maintenance on the device, review the documentation for the procedure you are about to perform, paying special attention to the safety warnings.



Note Do not unpack the device until you are ready to install it. Keep the chassis in the shipping container to prevent accidental damage until you determine an installation site. Use the appropriate unpacking documentation included with the device.

Read the installation instructions in this document before you connect the device to its power source. Failure to read and follow these guidelines could lead to an unsuccessful installation and possibly damage the device and components.

Safety Recommendations

The following guidelines will help to ensure your own safety and protect your Cisco equipment. This list does not cover all potentially hazardous situations, so *be alert*.

- Never attempt to lift an object that might be too heavy for you to lift by yourself.
- Always turn all power supplies off and unplug all power cables before opening the chassis.
- Always unplug the power cable before installing or removing a chassis.
- Keep the chassis area clear and dust free during and after installation.
- Keep tools and chassis components away from walk areas.
- Do not wear loose clothing, jewelry (including rings and chains), or other items that could get caught in the chassis. Fasten your tie or scarf and sleeves.
- The device operates safely when it is used in accordance with its marked electrical ratings and product-usage instructions.

General Safety Warnings

This section lists some of the safety warnings applicable to the Cisco Remote-PHY Compact Shelf. For the other applicable safety warnings, see *Regulatory Compliance and Safety Information for the Cisco Remote-PHY Compact Shelf*.



Warning **Statement 1073**—No User-Serviceable Parts

No user-serviceable parts inside. Do not open.



Warning **Statement 1005**—Double Pole Circuit Breaker

This product relies on the building's installation for short-circuit (overcurrent) protection. Ensure that the protective device is rated not greater than:

- AC: 20 A U.S. maximum
 - DC: 20 A U.S. maximum
-



Warning **Statement 1019**—Main Disconnecting Device

The plug-socket combination must be accessible at all times, because it serves as the main disconnecting device.



Warning **Statement 1086**—Power Terminals, Replace Cover

Hazardous voltage or energy may be present on power terminals. Always replace cover when terminals are not in service. Be sure uninsulated conductors are not accessible when covers is in place.

Site Planning

This section contains site-planning information, and will help you plan for the installation of the Cisco Remote-PHY Compact Device Shelf.

General Precautions

Observe the following general precautions when using and working with the Cisco Remote-PHY Compact Device Shelf:

- Keep your system components away from radiators and heat sources and do not block cooling vents.
- Do not spill food or liquids on your system components and never operate the product in a wet environment.
- Do not push any objects into the openings of your system components. Doing so can cause fire or electric shock by shorting out interior components.
- Position system cables and power supply cable carefully. Route system cables and power supply cable and plug such that they cannot be stepped on or tripped over. Be sure that nothing else rests on your system component cables or power cable.
- Do not modify power cables or plugs. Consult a licensed electrician or your power company for site modifications. Always follow your local and national wiring rules.
- If you turn off your system, wait at least 30 seconds before turning it on again to avoid system component damage.

Site Selection Guidelines

The Cisco Remote-PHY Compact Device Shelf require specific environmental operating conditions. Temperature, humidity, altitude, and vibration can affect the performance and reliability of the device. The following sections provide specific information to help you plan for a proper operating environment.

Site Environmental Requirements

Environmental monitoring protects the system and components from damage caused by excessive voltage and temperature conditions. To ensure normal operation and avoid unnecessary maintenance, plan and prepare your site configuration before installation. After installation, make sure the site maintains the environmental characteristics, as shown in the following table.

Environmental Requirements for the Cisco Remote-PHY Compact Shelf

The table below lists the operating and non-operating environmental site requirements. The ranges listed are those within which the equipment continues to operate; however, a measurement that is approaching the minimum or maximum of a range indicates a potential problem. You can maintain normal operation by anticipating and correcting environmental anomalies before they approach a maximum operating range.

Table 5: Specifications for Operating and Non-operating Environments for the Cisco Remote-PHY Compact Shelf

Specification	Minimum
Power Consumption	6*12: Typical 510W
	3*6: Typical 310W
Thermal Heat Dissipation	6*12: Typical 510W
	3*6: Typical 310W
Mean Time Between Failure (MTBF)	6*12: 121,480 hours
	3*6: 209,150 hours
Temperature Range	Operating: -40 to 140°F (-40 to 60°C)
	Non-operating: -40 to 185°F (-40 to 85°C)
Relative Humidity	5 to 90% non-condensing
Operating Altitude	0 to 10000 ft (0 to 3048 m)

Environmental Requirements for the Cisco CCAP RF Line Card

The table below lists the operating and non-operating environmental site requirements. The ranges listed are those within which the equipment continues to operate; however, a measurement that is approaching the minimum or maximum of a range indicates a potential problem. You can maintain normal operation by anticipating and correcting environmental anomalies before they approach a maximum operating range.

Table 6: Specifications for Operating and Non-operating Environments for the Cisco CCAP RF Line Card

Specification	Minimum
Power Consumption	211 W
Thermal Heat Dissipation	211 W
Mean Time Between Failure (MTBF)	360,870 hours
Temperature Range	Operating: 41 to 140°F (5 to 60°C)
	Non-operating: -4 to 149°F (-20 to 65°C)
Relative Humidity	Operating: 10 to 90% non-condensing
	Non-operating: 10 to 90%
Operating Altitude	-196 to 13,123 ft. (-60 to 4000 m)

Physical Characteristics

Be familiar with the physical characteristics of the Cisco Remote-PHY Compact Device Shelf to assist you in placing the system at a proper location.



Note For information regarding rack widths supported for the Cisco Remote-PHY Compact Device Shelf, see [General Rack-Selection Guidelines, on page 29](#).

The following table shows the weight and dimensions of the Cisco Remote-PHY Compact Device Shelf:

Table 7: Physical Characteristics of the Cisco Remote-PHY Compact Device Shelf

Characteristic	Cisco Remote-PHY Compact Device Shelf
Height	1.72 in. (43.69 mm)—1RU; rack-mount per EIA RS-310
Width	17.3 in. (439.42 mm)
Depth	21.78 in. (553.2 mm) Depth includes card handles, cable-management brackets, and power-supply handles
Weight	24 lb (11.3 kg)

The following list describes additional characteristics:

- Chassis height meets EIA-310 rack spacing 1RU (1.75 in. or 44.45 mm), universal rack mount
- Chassis width meets EIA-310 19 in. (17.3 in. or 439.42 mm) wide with rack brackets
- Ships with forward rack-mount brackets installed and an extra set included in the accessory kit

Site Power Guidelines

The Cisco Remote-PHY Compact Device Shelf has specific power and electrical wiring requirements. Adhering to these requirements ensures reliable operation of the system. Follow these precautions and recommendations when planning your site for the Cisco Remote-PHY Compact Device Shelf:

- The redundant power option provides a second, identical power supply to ensure that power to the chassis continues uninterrupted if one power supply fails or input power on one line fails.
- In systems configured with the redundant power option, connect each of the two power supplies to a separate input power source. If you fail to do this, your system might be susceptible to total power failure due to a fault in the external wiring or a tripped circuit breaker.
- To prevent a loss of input power, be sure the total maximum load on each circuit supplying the power supplies is within the current ratings of the wiring and breakers.
- Check the power at your site before installation, and periodically after installation, to ensure that you are receiving clean power. Install a power conditioner if necessary.
- Provide proper grounding to avoid personal injury and damage to the equipment due to lightning striking power lines or due to power surges. The chassis ground must be attached to a central office or other interior ground system.



Caution This product requires short-circuit (overcurrent) protection to be provided as part of the building installation. Install only in accordance with national and local wiring regulations.



Note The Cisco Remote-PHY Compact Device Shelf installation must comply with all applicable codes and is approved for use with copper conductors only. The ground bond fastening hardware should be of compatible material and preclude loosening, deterioration, and electrochemical corrosion of hardware and joined material. Attachment of the chassis ground to a central office or other interior ground system must be made with an AWG #6 gauge wire, copper ground conductor at a minimum.

Electrical Circuit Requirements

Each Cisco Remote-PHY Compact Device Shelf requires a dedicated electrical circuit. If you equip it with dual-power feeds, you must provide a separate circuit for each power supply to avoid compromising the power redundancy feature.

The Cisco Remote-PHY Compact Device Shelf can be powered by a DC or AC source. Ensure that equipment grounding is present and observe power-strip ratings. Make sure that the total ampere rating of all the products plugged into the power strip does not exceed 80 percent of the rating.



Note The Cisco Remote-PHY Compact Device Shelf can support two AC or two DC power supplies. Do not install mixed AC and DC power supply units in the same chassis.

The following table contains specifications for DC-powered systems for the Cisco Remote-PHY Compact Device Shelf.

Table 8: Cisco Remote-PHY Compact Device Shelf DC Power Supply System Input Requirements

System Input Rating (Amps)	Circuit Breaker Rating (Amps)	AWG # Wire
12	20, double pole	10 or 12

The following table contains specifications for AC-powered systems for the Cisco Remote-PHY Compact Device Shelf.

Table 9: Cisco Remote-PHY Compact Device Shelf AC Power Supply System Input Requirements

System Input Rating (Amps)	Circuit Breaker Rating (Amps)
6	20, double pole



Note The Cisco Remote-PHY Compact Device Shelf AC power supply requires a 20 A circuit breaker.

The following table lists AC and DC power supply system rating requirements for the Cisco Remote-PHY Compact Device Shelf.

Table 10: AC and DC Power Supply Specifications for the Cisco Remote-PHY Compact Device Shelf

Description	Specification
Power supply voltage range	AC = 90–264 VAC DC = –40.5–72 VDC
Power supply declared ratings	AC = 100–240 VAC DC = –48/–60 VDC
Line frequency rating	50/60 Hz for AC power supplies

Site Cabling Guidelines

This section contains guidelines for wiring and cabling at your site. When preparing your site for network connections to the Cisco Remote-PHY Compact Device Shelf, consider the type of cable required for each component, and the cable limitations. Consider the distance limitations for signaling, EMI, and connector compatibility. Possible cable types are fiber, thick or thin coaxial, foil twisted-pair cabling, or unshielded twisted-pair cabling.

Also consider any additional interface equipment you need, such as transceivers, hubs, switches, modems, channel service units (CSUs), or data service units (DSUs).

Before you install the Cisco Remote-PHY Compact Device Shelf, have all the additional external equipment and cables at hand. For ordering information, contact a Cisco customer service representative.

The extent of your network and the distances between network interface connections depend in part on the following factors:

- Signal type
- Signal speed
- Transmission medium

The distance and rate limits referenced in the following sections are the IEEE-recommended maximum speeds and distances for signaling purposes. Use this information as guidelines when planning your network connections prior to installing the Cisco Remote-PHY Compact Device Shelf.

If wires exceed recommended distances, or if wires pass between buildings, give special consideration to the effect of a lightning strike in your vicinity. The electromagnetic pulse caused by lightning or other high-energy phenomena can easily couple enough energy into unshielded conductors to destroy electronic devices. If you have had problems of this sort in the past, you may want to consult experts in electrical surge suppression and shielding.

Console Port Connections

The Cisco Remote-PHY Compact Device Shelf provide console and auxiliary ports to connect a terminal or computer for local console access.

Both ports have RJ-45 connectors, support RS-232 asynchronous data, and have distance recommendations specified in the IEEE RS-232 standard.

Interference Considerations

When wires are run for a significant distance, there is a risk that stray signals will be induced on the wires as interference. If interference signals are strong, they can cause data errors or damage to the equipment.

The following sections describe sources of interference and how to minimize its effects on the Cisco Remote-PHY Compact Device Shelf.

Electromagnetic Interference

All the equipment powered by AC current can propagate electrical energy that can cause electromagnetic interference (EMI) and possibly affect the operation of other equipment. The typical sources of EMI are equipment power cords and power service cables from electric utility companies.

Strong EMI can destroy the signal drivers and receivers in the Cisco Remote-PHY Compact Device Shelf and even create an electrical hazard by causing power surges through power lines into installed equipment. These problems are rare, but could be catastrophic.

To resolve these problems, you need specialized knowledge and equipment, which could consume substantial time and money. However, you should ensure that you have a properly grounded and shielded electrical environment, paying special attention to the need for electrical surge suppression.

The following table lists electrode magnetic compliance standards for the Cisco Remote-PHY Compact Device Shelf.

Table 11: EMC and Safety Standards

EMC Standards	
----------------------	--

Electromagnetic Emissions Certification

- EN50083-2 - Europe
- KN 32 Class A - Korea
- FCC Part 15 Class A - United States
- ICES 003 Class A - Canada
- AS/NZS Class A - Australia
- CISPR 22 Class A - Europe
- EN55022 Class A - Europe
- VCCI Class A - Japan
- CNS13438 Class A - Taiwan
- IEC/EN61000-3-2 Power Line Harmonics - Europe
- IEC/EN61000-3-3 Voltage Fluctuations and Flicker - Europe

Immunity

- EN50083-2 - Europe
- CISPR 24 - Europe
- KN 35 - Korea
- IEC/EN61000-4-2 Electrostatic Discharge Immunity (8kV contact, 15kV air)
- IEC/EN61000-4-3 Radiated Immunity (10V/m)
- IEC/EN61000-4-4 Electrical Fast Transient Immunity (2kV power, 1kV signal)
- IEC/EN61000-4-5 Surge AC Port (4kV CM, 2kV DM)
- IEC/EN61000-4-5 Surge Signal Port (1kV)
- IEC/EN61000-4-5 Surge DC Port (1kV)
- IEC/EN61000-4-6 Immunity to Conducted Disturbances (10Vrms)
- IEC/EN61000-4-8 Power Frequency Magnetic Field Immunity (30A/m)
- IEC/EN61000-4-11 Voltage Dips, Short Interruptions, and Voltage Variations

European Telecommunication Standards Institute (ETSI)

- EN 300 386 Telecommunications Network Equipment (EMC)
- EN50083-2 Cable networks for television signals, sound signals and interactive services

	<ul style="list-style-type: none"> • EN55022 Information Technology Equipment (Emissions) • EN55024 Information Technology Equipment (Immunity) • EN61000-6-1 Generic Immunity Standard • EN61000-6-2 Generic Immunity Standard for Industrial Environments
Safety Standards	<ul style="list-style-type: none"> UL60950-1 CSA C22.2 No. 60950-1-03 EN 60950-1 IEC 60950-1 AS/NZS 60950.1 IEC 60825-1

Radio Frequency Interference

When electromagnetic fields act over a long distance, radio frequency interference (RFI) can be propagated. Building wiring can often act as an antenna, receiving the RFI signals and creating more EMI on the wiring.

If you use twisted-pair cable in your plant wiring with a good distribution of grounding conductors, the plant wiring is unlikely to emit radio interference. If you exceed the recommended distances, use a high-quality twisted-pair cable with one ground conductor for each data signal.

Lightning and AC Power Fault Interference

If signal wires exceed recommended cabling distances, or if signal wires pass between buildings, you should consider the effect that a lightning strike in your vicinity might have on the Cisco Remote-PHY Compact Device Shelf.

The electromagnetic pulse (EMP) generated by lightning or other high-energy phenomena can couple enough energy into unshielded conductors to damage or destroy electronic equipment. If you have previously experienced such problems, you should consult with RFI/EMI experts to ensure that you have adequate electrical surge suppression and shielding of signal cables in your Cisco Remote-PHY Compact Device Shelf operating environment.

Rack-Mounting Guidelines

This section describes guidelines on rack-mounting.

Precautions for Rack-Mounting

The following rack-mounting guidelines are provided to ensure your safety:

- Do not move large racks by yourself. Due to the height and weight of a rack, a minimum of two people are required to accomplish this task.
- Ensure that the rack is level and stable before extending a component from the rack.
- Ensure that proper airflow is provided to the components in the rack.

- Do not step or stand on any component or system when servicing other systems or components in a rack.
- When mounting the Cisco Remote-PHY Compact Device Shelf in a partially filled rack, load the rack from the bottom to the top with the heaviest component at the bottom of the rack.
- If the rack is provided with stabilizing devices, install the stabilizers before mounting or servicing the unit in the rack.

General Rack-Selection Guidelines

The Cisco Remote-PHY Compact Device Shelf can be mounted in most two-post 19-in. equipment racks that comply with the Electronics Industries Association (EIA) standard for equipment racks (EIA-310-D 19-in.). The rack must have at least two posts with mounting flanges to mount the chassis.



Caution When mounting a chassis in any type of rack equipment, ensure that the inlet air to the chassis does not exceed 131°F (55°C).

The distance between the center lines of the mounting holes on the two mounting posts must be 18.31 in. ± 0.06 in. (46.50 cm ± 0.15 cm). The rack-mounting hardware included with the chassis is suitable for most 19-in. (48.3-cm) equipment racks.

Consider installing the Cisco Remote-PHY Compact Device Shelf in a rack with the following features:

- 19-in. (48.3-cm) wide rack.
- EIA or ETSI hole patterns in the mounting rails. Required mounting hardware is shipped with the Cisco Remote-PHY Compact Device Shelf. If the rack that you plan to install the system in has metric-threaded rails, you must provide your own metric-mounting hardware.
- Perforated top and open bottom for ventilation to prevent overheating.
- Leveling feet for stability.



Note The Cisco Remote-PHY Compact Device Shelf should not be installed in an enclosed rack because the chassis requires an unobstructed flow of cooling air to maintain acceptable operating temperatures for its internal components. Installing the device in any type of enclosed rack—even with the front and back doors removed—could disrupt the air flow, trap heat next to the chassis, and cause an overtemperature condition inside the device. If you use an enclosed rack, make certain that there are air vents on all sides of the rack and there is proper ventilation.

Equipment Rack Guidelines

The placement of racks can affect personnel safety, system maintenance, and the system's ability to operate within the environmental characteristics. Choose a proper location for the Cisco Remote-PHY Compact Device Shelf by following the guidelines below.

Locating for Safety

If the Cisco Remote-PHY Compact Device Shelf is the heaviest or the only piece of equipment in the rack, consider installing it at or near the bottom to ensure that the rack's center of gravity is as low as possible.

Locating for Easy Maintenance

Keep at least 3 feet of clear space in front of and behind the rack. This space ensures that you can remove the Cisco Remote-PHY Compact Device Shelf components and perform routine maintenance and upgrades easily.

Avoid installing the Cisco Remote-PHY Compact Device Shelf in a congested rack and consider how the routing of cables from other pieces of equipment in the same rack might affect access to the device.

The front and top of the chassis must remain unobstructed to ensure adequate airflow and prevent overheating inside the chassis.

Allow the following clearances for normal system maintenance:

- At the top of the chassis—At least 3 in. (7.6 cm)
- At the bottom of the chassis—At least 0.2 in. (5 mm)
- In front of the chassis and behind the chassis—3 to 4 ft (91.44 cm to 121.92 cm)

To avoid problems during installation and ongoing operation, follow these general precautions when you plan the equipment locations and connections:

- Use the **show environment all** and the **show facility-alarm status** commands regularly to check the internal system status. The environmental monitor continually checks the interior chassis environment; it provides warnings for high temperature and creates reports on any occurrences. If warning messages are displayed, take immediate action to identify the cause and correct the problem.
- Keep the Cisco Remote-PHY Compact Device Shelf off the floor and out of the areas that collect dust.
- Follow ESD-prevention procedures to avoid damage to equipment. Damage from static discharge can cause immediate or intermittent equipment failure.

Locating for Proper Airflow

Ensure that the location of the Cisco Remote-PHY Compact Device Shelf has enough airflow to keep the system operating within the environmental characteristics, and the air temperature is sufficient to compensate for the heat dissipated by the system.

Avoid locating the Cisco Remote-PHY Compact Device Shelf in a location in which the chassis air intake vents could draw in the exhaust air from adjacent equipment. Consider how the air flows through the device. The airflow direction is front to back with ambient air drawn in from the venting located on the chassis' front sides.

Preventing Electrostatic Discharge Damage

Electrostatic discharge (ESD) damage occurs when electronic cards or components are improperly handled resulting in complete or intermittent failures. Static electricity can harm delicate components inside your system. To prevent static damage, discharge static electricity from your body before you touch any of your system components, such as a microprocessor. As you continue to work on your system, periodically touch an unpainted metal surface on the computer chassis.

The following are guidelines for preventing ESD damage:

- Always use an ESD-preventive wrist or ankle strap and ensure that it makes good skin contact. Before removing a card from the chassis, connect the equipment end of the strap to the ESD plug at the bottom of the chassis below the power entry modules.

- Handle line cards by faceplates and carrier edges only; avoid touching the card components or connector pins.
- When removing a module, place the removed module component-side-up on an antistatic surface or in a static-shielding bag. If the module is to be returned to the factory, immediately place it in a static-shielding bag.
- Avoid contact between the modules and clothing. The wrist strap protects the card from ESD voltages only on the body; ESD voltages on clothing can still cause damage.
- When transporting a sensitive component, place it in an antistatic container or packaging.
- Handle all sensitive components in a static-safe area. If possible, use antistatic floor pads and workbench pads.

**Caution**

For safety, periodically check the resistance value of the antistatic strap. The measurement should be between 1 and 10 ohms.

**Caution**

Always tighten the captive installation screws on all the system components when you are installing them. These screws prevent accidental removal of the module, provide proper grounding for the system, and help ensure that the bus connectors are properly seated in the backplane.

Electrical Safety

All the system components are hot-swappable. They are designed to be removed and replaced while the system is operating, without presenting an electrical hazard or damage to the system.

Follow these basic guidelines when you are working with any electrical equipment:

- Before beginning any procedures requiring access to the chassis interior, locate the emergency power-off switch for the room in which you are working.
- Disconnect all power and external cables before installing or removing a chassis.
- Do not work alone when potentially hazardous conditions exist.
- Never assume that power has been disconnected from a circuit; always check.
- Do not perform any action that creates a potential hazard to people or makes the equipment unsafe. Never install equipment that appears damaged.
- Carefully examine your work area for possible hazards such as moist floors, ungrounded power extension cables, and missing safety grounds.

In addition, use the following guidelines when working with any equipment that is disconnected from a power source, but is still connected to telephone wiring or other network cabling:

- Never install telephone wiring during a lightning storm.
- Never install telephone jacks in wet locations unless the jack is specifically designed for wet locations.

- Never touch uninsulated telephone wires or terminals unless the telephone line has been disconnected at the network interface.
- Use caution when installing or modifying telephone lines.



Warning **Statement 1001—Work During Lightning Activity**

Do not work on the system or connect or disconnect cables during periods of lightning activity.

Chassis-Lifting Guidelines

The chassis is not intended to be moved frequently. Before you install the system, ensure that your site is properly prepared so that you can avoid having to move the chassis later to accommodate power sources and network connections.

Each time you lift the chassis or any heavy object, follow these guidelines:

- Ensure that your footing is solid, and balance the weight of the chassis between your feet.
- Lift the chassis slowly; never move suddenly or twist your body as you lift.
- Keep your back straight and lift with your legs, not your back. If you must bend down to lift the chassis, bend at the knees, not at the waist, to reduce the strain on your back muscles.
- Do not remove installed components from the chassis.
- Always disconnect all external cables before lifting or moving the chassis.

Tools and Equipment

The following tools and equipment are recommended as the minimum necessary equipment to install the Cisco Remote-PHY Compact Device Shelf. You may need additional tools and equipment to install associated equipment and cables. You may also require test equipment to check electronic and optical signal levels, power levels, and communications links.

- Phillips hand screwdriver
- 3.5-mm flat-blade screwdriver
- Tape measure (optional)
- Level (optional)
- Power drill
- 8-gauge wire
- Rack-mount brackets

You need the following tools to install and cable the Cisco CCAP RF line card:

- T-10 Torx driver tool

- 1/4-inch flathead screwdriver
- Blank Cisco cBR-8 slot cover (if required)
- ESD-preventive wrist strap
- Antistatic surface, such as a mat or antistatic bag

Unpacking and Verifying Shipping Contents

When you receive your chassis, perform the following steps and use the shipping contents checklist in the following section.

Procedure

-
- Step 1** Inspect the box for any shipping damage. (If there is damage, contact your Cisco service representative).
- Step 2** Unpack the Cisco Remote-PHY Compact Device Shelf.
- Step 3** Perform a visual inspection of the chassis.
- Step 4** After you have unpacked the system, verify that you have received all of the required components, including all the accessory items. Using the packing list as a guide, verify that you have received all the equipment listed in your order, and ensure that the configuration matches the packing list.
-

Checking the Shipping Container Contents

Use the components list shown in the following table to check the contents of the Cisco Remote-PHY Compact Device Shelf shipping container. Do not discard the shipping container. You need the container if you move or have to ship the Cisco Remote-PHY Compact Device Shelf in the future.

Table 12: Cisco Remote-PHY Compact Device Shelf Shipping Container Contents

Component	Description
Chassis	Cisco Remote-PHY Compact Device Shelf are configured with dual AC or dual DC power supplies.
Accessories Kit	2 Rack-mount brackets and 1 grounding lug.
Note You must order the Accessories Kit separately if you order the Cisco Remote-PHY Compact Device Shelf chassis as a spare.	Two sets of screws, one each for: <ul style="list-style-type: none"> • Rack-mount brackets (12 flat head screws (silver)) • Grounding lug (2 screws (silver) with star washers)
Optional Equipment	Power cord if an AC power supply was shipped. There are none for the DC power supply units.

Installation Checklist

To assist you with your installation and to provide a historical record of what was done by whom, print or photocopy the Installation Checklist below. Use this to record when each procedure or verification is completed. When the checklist is completed, place it in your site log along with the other records for your new device.

Table 13: Installation Checklist

Task	Verified By	Date
Date chassis received		
Chassis and all accessories unpacked		
Types and numbers of interfaces verified		
Safety recommendations and guidelines reviewed		
Installation Checklist copied		
Site log established and background information entered		
Site power voltages verified		
Site environmental specifications verified		
Required passwords, IP addresses, device names, and so on, available		
Required tools available		
Network connection equipment available		
AC power cable(s) connected to AC source(s) and device		
DC power cable(s) connected to DC source(s) and device		
Network interface cables and devices connected		
System power turned on		
System boot complete (STATUS LED is on)		
Ethernet port adapters and NIMs (where applicable) are operational		
Correct hardware configuration displayed after system banner appears		

Task	Verified By	Date
Correct licenses installed on the device		



CHAPTER 4

Installing the Cisco Remote PHY Solution

- [Installation Methods, on page 37](#)
- [Guidelines for Rack Installation, on page 37](#)
- [Attaching the Front Rack-Mount Brackets, on page 39](#)
- [Attaching the Rear Rack-Mount Brackets, on page 40](#)
- [Mounting the Cisco Remote-PHY Compact Shelf in the Rack, on page 41](#)
- [Chassis Ground Connection, on page 43](#)
- [Connecting Cables, on page 45](#)

Installation Methods

The Cisco Remote-PHY Compact Device Shelf are designed for standalone, 2-rail 19-inch rack-mount installations.



Note Proceed with the installation if you have already unpacked your chassis and read all the site requirements for your new equipment.

Guidelines for Rack Installation

The Cisco Remote-PHY Compact Device Shelf can be installed in two-post rack. Inner clearance (the width between the inner sides of the two posts or rails) must be at least 19 inches (48.26 cm). Airflow through the chassis is from front to back.

The Cisco Remote-PHY Compact Device Shelf can be installed with both front or rear rack-mount brackets.

When planning your rack installation, consider the following guidelines:

- The Cisco Remote-PHY Compact Device Shelf requires a minimum of 1.75 inches or 4.45 cm rack units of vertical rack space. Measure the proposed rack location before mounting the chassis in the rack.
- Before using a particular rack, check for obstructions (such as a power strip) that could impair rack-mount installation. If a power strip does impair a rack-mount installation, remove the power strip before installing the chassis, and then replace it after the chassis is installed.

- Allow sufficient clearance around the rack for maintenance. If the rack is mobile, you can push it back near a wall or cabinet for normal operation and pull it out for maintenance (installing or moving cards, connecting cables, or replacing or upgrading components). Otherwise, allow 19 inches (48.3 cm) of clearance to remove field-replaceable units.
- Maintain a minimum clearance of 3 inches on the front and back sides of the chassis for the cooling air inlet and exhaust ports, respectively. Avoid placing the chassis in an overly congested rack or directly next to another equipment rack; the heated exhaust air from other equipment can enter the inlet air vents and cause an overtemperature condition inside the device.



Caution To prevent chassis overheating, never install a Cisco Remote-PHY Compact Device Shelf in an enclosed space that is not properly ventilated or air conditioned.

- Always install heavier equipment in the lower half of a rack to maintain a low center of gravity to prevent the rack from falling over.
- Ensure that cables from other equipment already installed in the rack do not impair access to the cards or require you to disconnect cables unnecessarily to perform equipment maintenance or upgrades.
- Provide an adequate chassis ground (earth) connection for your chassis.

In addition to the preceding guidelines, review the precautions for avoiding excessive temperature conditions in the “[Physical Characteristics](#)” section and the “[Site Environmental Requirements](#)” section.

Verifying Rack Dimensions

Before you install the chassis, measure the space between the vertical mounting flanges (rails) on your equipment rack to verify that the rack conforms to the measurements shown in the following figure.

Figure 10: Verifying Equipment Rack Dimensions

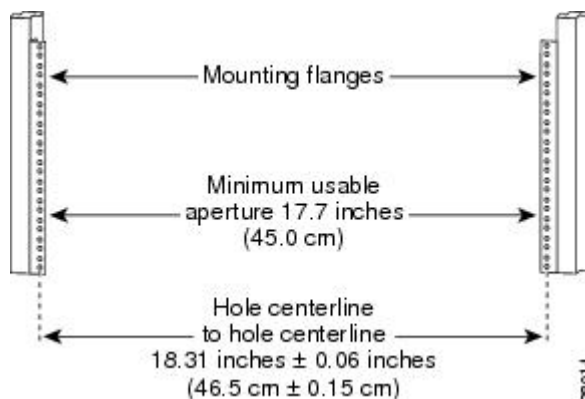

Procedure

- Step 1** Mark and measure the distance between two holes on the left and right mounting rails. The distance should measure 18.31 inches \pm 0.06 inches (46.5 cm \pm 0.15 cm).

Note Measure for pairs of holes near the bottom, middle, and top of the equipment rack to ensure that the rack posts are parallel.

Step 2 Measure the space between the inner edges of the left front and right front mounting flanges on the equipment rack.

The space must be at least 17.7 inches (45 cm) to accommodate the chassis that is 17.25 inches (43.8 cm) wide and fits between the mounting posts on the rack.

Attaching the Front Rack-Mount Brackets

Before you begin

Before installing the chassis in the rack, you must install the rack-mount brackets on each side of the chassis.

Determine where in the rack you want the chassis to be mounted. If you are mounting more than one chassis in the rack, then start from the bottom up or the center of the rack. The following figure shows the brackets attached to the chassis. Depending on the bracket holes you use, the chassis may protrude in the rack.

Procedure

Step 1 Locate the threaded holes on the side of the chassis. Ensure that you hold the front rack-mount bracket with the ear and holes facing outward and towards the front of the chassis.

The following figures show where to attach the front rack-mount brackets to the Cisco Remote-PHY Compact Device Shelf.

Figure 11: Attaching the Front Rack-Mount Brackets to the Cisco Remote-PHY Compact Device Shelf

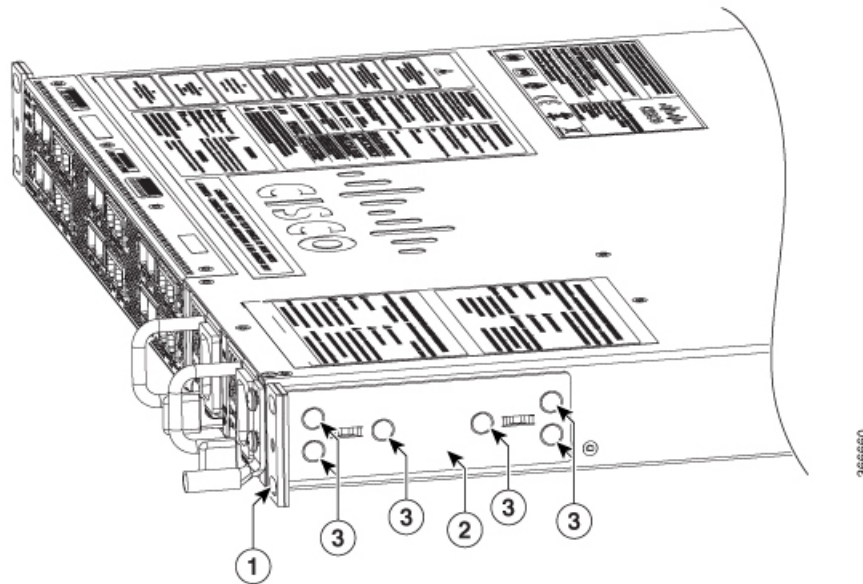

1	Front rack-mount bracket ear and holes	3	Front rack-mount bracket screws
2	Front rack-mount bracket		

- Step 2** Position the front rack-mount bracket top hole with the chassis, first top hole behind the side vent holes.
- Step 3** Insert and tighten the black screws on one side.
- Step 4** Repeat Step 1 through Step 3 on the other side of the chassis. Use black screws to secure the rack-mount brackets to the chassis.

Attaching the Rear Rack-Mount Brackets

Before you begin

Determine where in the rack you want the chassis to be mounted. If you are mounting more than one chassis in the rack, then start from the bottom up or the center of the rack. The following figure shows the brackets attached to the chassis.

Procedure

- Step 1** Locate the threaded holes on the side of the chassis. Ensure that you hold the rear rack-mount bracket with the ear and holes facing outward and towards the rear of the chassis.

The following figures show where to attach the rear rack-mount brackets to the Cisco Remote-PHY Compact Device Shelf.

Figure 12: Attaching the Rear Rack-Mount Brackets to the Cisco Remote-PHY Compact Shelf

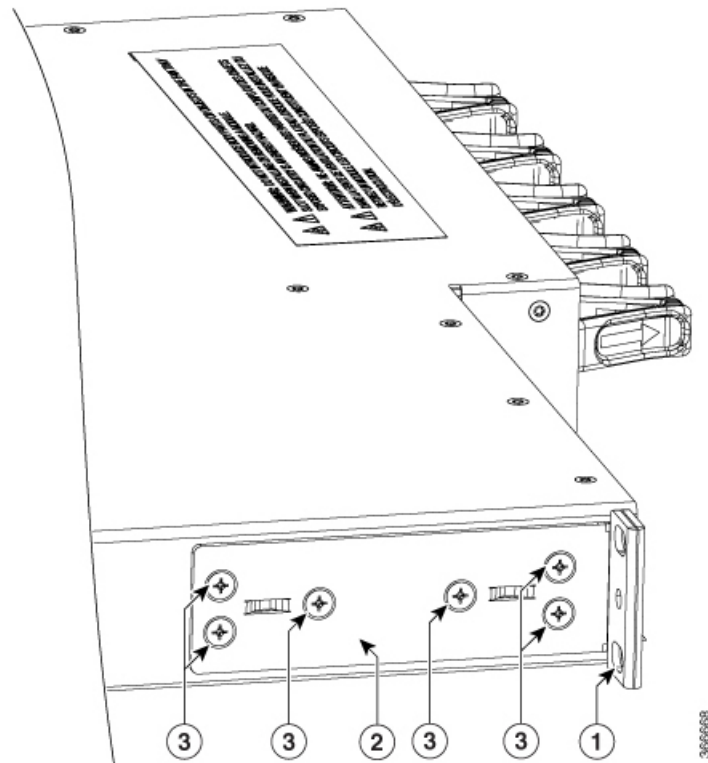

1	Rear rack-mount bracket ear and holes	3	Rear rack-mount bracket screws
2	Rear rack-mount bracket		

- Step 2** Position the rear rack-mount bracket with the chassis.
- Step 3** Insert and tighten the black screws on one side.
- Step 4** Repeat Step 1 through Step 3 on the other side of the chassis. Use black screws to secure the rack-mount brackets to the chassis.

Mounting the Cisco Remote-PHY Compact Shelf in the Rack

After installing the rack-mount brackets on the chassis, mount the chassis by securing the rack-mount brackets to two posts or mounting strips in the rack using the screws provided. Because the rack-mount brackets support the weight of the entire chassis, ensure that you use all the screws to fasten the two rack-mount brackets to the rack posts.

The Cisco Remote-PHY Compact Device Shelf can be installed on a 19 inch two-post rack. We recommend that you allow at least 1 or 2 inches (2.54 or 5.08 cm) of vertical clearance between the Cisco Remote-PHY Compact Shelf and any equipment directly above and below it.

Procedure

-
- Step 1** On the chassis, ensure that all the screw fasteners on the installed components are securely tightened.
- Step 2** Make sure that your path to the rack is unobstructed. If the rack is on wheels, ensure that the brakes are engaged or that the rack is otherwise stabilized.
- Step 3** With two people, lift the chassis into position between the rack posts.
- Step 4** Align the mounting bracket holes with the rack post holes and attach the chassis to the rack.
- Step 5** Position the chassis until the rack-mounting flanges are flush against the mounting rails on the rack.
- Step 6** Hold the chassis in position against the mounting rails in the equipment rack and follow these steps:
- Insert the bottom screw into the second hole up from the bottom of the rack-mount ear and use a hand-held screwdriver to tighten the screw to the rack rail.
- Tip** To make installation easier, insert one screw at the bottom of the chassis and the next screw at the top of the chassis diagonally from the first screw.
- Insert the top screw into the second hole from the top of the rack-mount ear diagonally from the bottom screw and tighten the screw to the rack rail.
 - Insert the rest of the screws to secure the chassis to the rack equipment.
- Step 7** Tighten all the screws on each side to secure the chassis to the equipment rack.

The following figures show the Cisco Remote-PHY Compact Device Shelf on a two-post equipment rack.

Figure 13: Cisco Remote-PHY Compact Shelf Installed on a Two-Post Equipment Rack

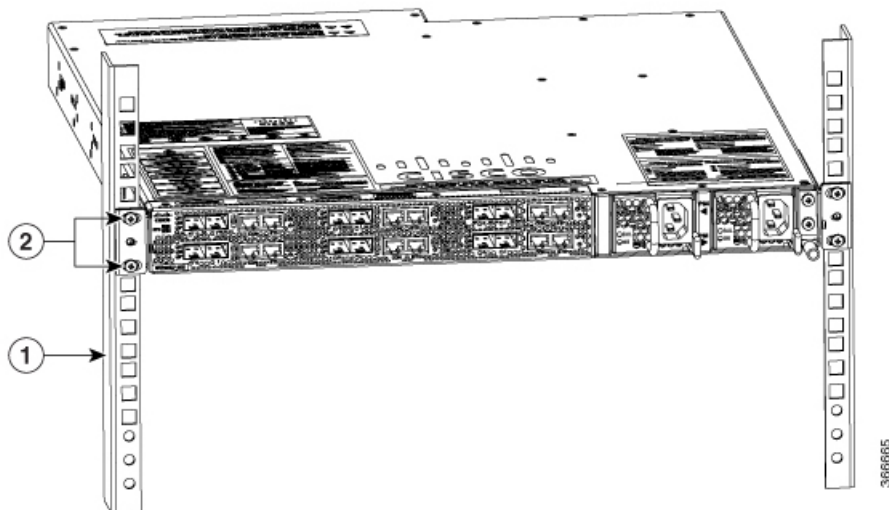

1	Rack equipment rail	2	Rack mount bracket ear and screws
---	---------------------	---	-----------------------------------

Chassis Ground Connection

Double hole Ground Lug connection is mandatory for both AC and DC chassis.

Before you connect power or turn on power to your chassis, you must provide an adequate chassis ground (earth) connection for the chassis. A chassis ground connector is provided on each Cisco Remote-PHY Compact Device Shelf. There is a stud on the rear left side of the chassis.



Caution The grounding wire should always be the first to be installed or connected and the last to be removed or disconnected. Use copper wire only.

Have the recommended tools and supplies available before you begin this procedure.

Recommended Tools and Supplies

The following tools, equipment, and supplies are necessary to connect the system ground to the chassis:

- Phillips screwdriver
- 3.5-mm flat blade screwdriver (Phoenix # 1205053 or equivalent 3.5-mm flat blade)
- Dual-lug chassis ground component
- Grounding wire

Attaching a Chassis Ground Connection

Procedure

- Step 1** Use the wire stripper to strip one end of the AWG #6 wire approximately 0.75 inches (19.05 mm).
- Step 2** Insert the AWG #6 wire into the open end of the grounding lug.

Figure 14: Attaching a Grounding Lug to the Chassis Ground Connector

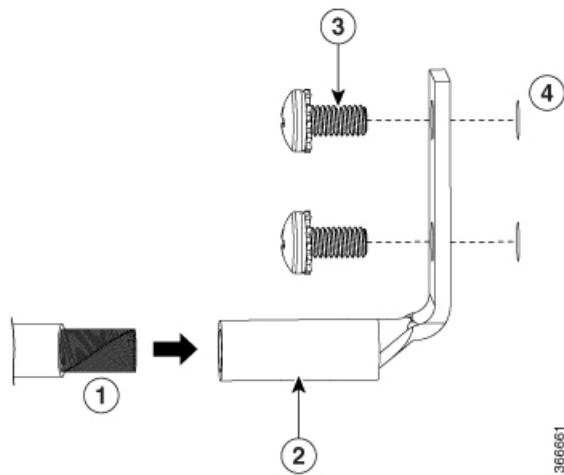

1	Chassis ground lead wire	3	Ground screws
2	Grounding lug	4	Chassis ground connector holes

Step 3 Use the crimping tool to carefully crimp the wire receptacle around the wire. This step is required to ensure a proper mechanical connection.

Step 4 Locate the chassis ground connector on the side of your chassis.

Step 5 Insert the two screws through the holes in the grounding lug.

The following figures show how to attach a grounding lug to the chassis ground connector.

Figure 15: Attaching the Grounding Lug to the Ground Connector of the Cisco Remote-PHY Compact Shelf

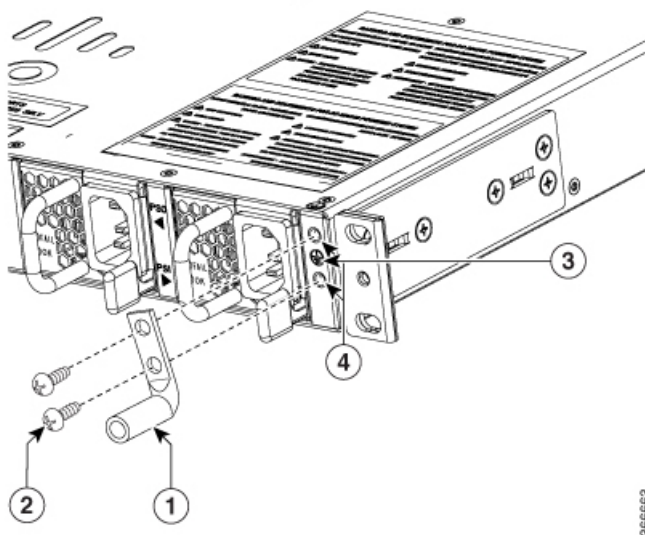

1	Chassis ground lug	3	Ground symbol
2	Grounding screws	4	Ground connector on the chassis

- Step 6** Use the Number 2 Phillips screwdriver to carefully tighten the screws until the grounding lug is held firmly to the chassis. Do not over tighten the screws.
- Step 7** Connect the opposite end of the grounding wire to the appropriate grounding point at your site to ensure an adequate chassis ground.

Connecting Cables

Keep the following guidelines in mind when connecting any external cable to the Cisco Remote-PHY Compact Device Shelf:

- To reduce the chance of interference, avoid crossing high-power lines with any interface cables.
- Verify all the cabling limitations (particularly distance) before powering on the system.

Connecting the Console Port Cable

Cisco Remote-PHY Compact Device Shelf uses RJ-45 ports for console ports to attach a console terminal. It has an asynchronous serial (EIA/TIA-232) RJ-45 console port labeled CON on its front panel. You can connect this port to most types of video terminals with a console cable kit which contains:

- One RJ-45-to-RJ-45 crossover cable
- One RJ-45-to-DB-9 (female) adapter

A crossover cable reverses pin connections from one end to the other. In other words, it connects pin 1 (at one end) to pin 8 (at the other end), pin 2 to pin 7, pin 3 to pin 6, and so on. You can identify a crossover cable by comparing the two modular ends of the cable. Hold the cable ends in your hand, side-by-side, with the tabs at the back. Ensure that the wire connected to the outside (left) pin of the left plug (pin 1) is the same color as the wire connected to the outside (right) pin of the right plug (pin 8).

Both the console and auxiliary ports are asynchronous serial ports; devices connected to these ports must be capable of asynchronous transmission.

Before connecting to the console interface on the Cisco Remote-PHY Compact Device Shelf using a terminal or PC, perform the following steps:

Procedure

- Step 1** Connect one end of the RJ-45 cable to the console port on the Cisco Remote-PHY Compact Device Shelf.

Figure 16: Connecting Console Port

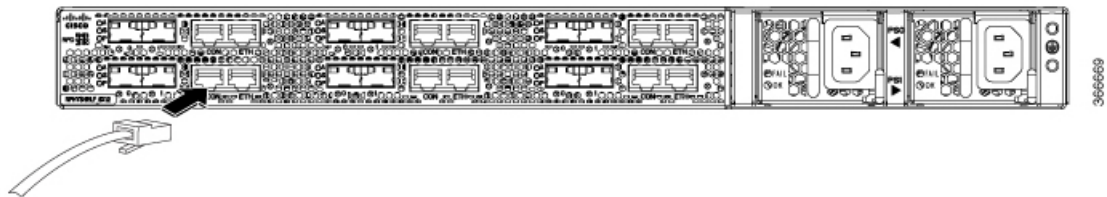

Step 2 Connect the other end of the RJ-45 cable to the RJ-45-to-DB-9 adapter.

Figure 17: Connecting an RJ-45-to-DB-9 Adapter

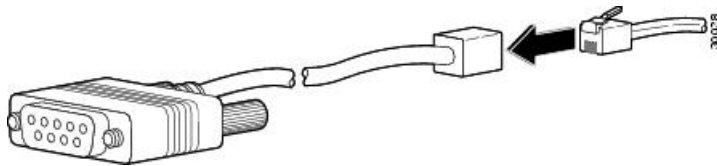

Step 3 Connect the RJ-45-to-DB-9 adapter to the appropriate serial port on the PC or terminal.

Step 4 Power up the PC or terminal.

Step 5 Configure the PC terminal emulation software or the terminal with the following settings:

- 115200 baud
- 8 data bits
- No parity generation or checking
- 1 stop bit
- No flow control

Connecting Management Ethernet Port Cable



Caution To comply with Class A emission requirements, a shielded Ethernet cable must be used for the connection.

Procedure

Step 1 Insert an Ethernet RJ-45 cable into the MGMT port.

Step 2 Insert the other end of the RJ-45 cable to your management device or network.

Installing the SFP+ Modules

Before you begin

**Caution**

Do not install or remove the SFP+ module with fiber-optic cables still attached to it. Doing so may damage cables, cable connectors, or the optical interfaces and may interfere with the SFP+ module latching properly into its socket connector. Disconnect all cables before removing or installing an SFP transceiver module.

- Attach an ESD-preventive wrist strap to your wrist and connect the other end to the grounding lug connected to the chassis.
- You must use the supported SFP+ modules. The following SFP+ modules are supported on the Cisco Remote-PHY Compact Device Shelf:
 - SFP-10G-SR
 - SFP-10G-LR
 - SFP-10G-ER
 - SFP-10G-ZR
 - SFP-10G-LRM
 - SFP-10G-AOC3M
 - SFP-10G-LR-S
- DWDM-SFP10G-C (User needs to configure the operating wavelength to a certain ITU channel after installing this tunable SFP+ module for the first time.)

Required Tools and Equipment

- ESD-preventive wrist strap
- SFP+ module

Procedure

Step 1 Remove the SFP+ module from its protective packaging.

Note Do not remove the optical bore dust plugs.

Figure 18: SFP+ Module with Dust Plugs

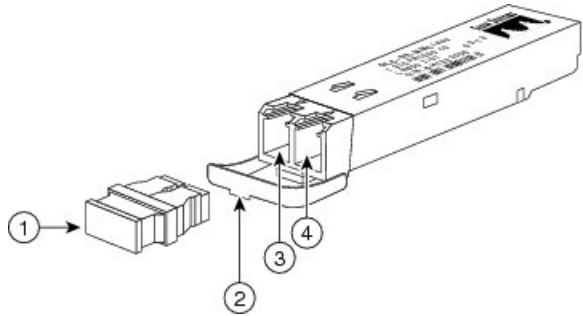

1	Dust plug	3	Transmit bore
2	Bail clasp with clasp tab	4	Receive bore

Step 2 Check the label on the SFP+ module to verify that you have the correct model for your network.

Step 3 Find the send (TX) and receive (RX) markings that identify the top side of the SFP+ module.

Note On some SFP modules, the TX and RX marking might be replaced by arrowheads pointing from the SFP+ module connector (transmit direction or TX) and towards the connector (receive direction or RX).

Step 4 Align the SFP+ module in front of the socket opening.

Step 5 Carefully insert the SFP+ module into the socket until you feel the connector latch into place.

Step 6 Press the SFP+ module into the slot firmly with your thumb until it is latched securely into the socket.

Step 7 Repeat step 1 to 6 for each SFP+ module.

What to do next

- Verify if the SFP+ module is seated and latched properly. Grasp the SFP+ module and try to remove it without releasing the latch. If the SFP+ module cannot be removed, it is installed and seated properly. If the SFP+ module can be removed, reinstall it.

Using the SFP+ Ports

Before you begin

- Do not remove the protective dust plugs on the unplugged fiber-optic cable connectors and the SFP+ optical bores until you are ready to make a connection.

Required Tools and Equipment

- Fiber-optic cable with the LC connector

Procedure

- Step 1** Remove the dust plugs from the network interface cable LC connectors. Save the dust plugs for future use.
- Step 2** [Inspect and clean the LC connector end-faces.](#)
- Step 3** Remove the dust plug from the SFP+ module optical.
- Step 4** Immediately connect the fiber-optic cable with cable LC connector to the SFP+ port.
- Important** Grasp the LC connector housing to connect the fiber-optic cable to the SFP+ ports.

Figure 19: LC fiber-optic connector

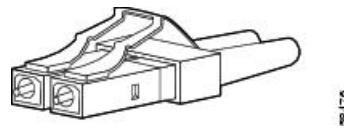

Using UCH.8 Connectors

The back faceplate of the Cisco Remote-PHY Compact Device Shelf has one downstream port cluster and two upstream port clusters. Three cable assemblies with UCH.8 connectors are used, one for each cluster, to connect the Cisco Remote-PHY Compact Device Shelf.

Connect the cable assemblies in the following order:

1. Red cable assembly to the downstream port cluster.
2. One blue cable assembly to upstream port cluster with the ports US0 to US7.
3. Other blue cable assembly to upstream port cluster with the ports US8 to US15.

The following steps describe how to connect one UCH.8 connector. Repeat the procedure to connect all the three UCH.8 connectors.

Before you begin

- Attach an ESD-preventive wrist strap to your wrist and connect the other end to the grounding lug connected to the chassis.

Required Tools and Equipment

- ESD-preventive wrist strap.
- 3/16" flat-blade torque screwdriver.
- Cable Bundle containing the following cable assemblies:
 - One cable assembly with red colored cables connected to one UCH.8 connector.
 - Two cable assemblies with blue colored cables connected to one UCH.8 connector each.

Procedure

- Step 1** Align the small and large guide pins in the UCH.8 connector with the small and large guide pin holes on the Cisco Remote-PHY Compact Device Shelf.
- Step 2** Insert the guide pins of the UCH.8 connector into the guide pin holes in the Cisco Remote-PHY Compact Device Shelf.
- Step 3** Hold the UCH.8 connector in place and tighten the lead screw using the 3/16" flat-head torque screwdriver, with a torque of 10-12 in-lbs.
-



CHAPTER 5

Configuring the Cisco Remote-PHY Solution

- [Prerequisites for Configuring the Cisco Remote-PHY Solution, on page 51](#)
- [Restrictions for Configuring the Cisco Remote-PHY Solution, on page 51](#)
- [How to Configure the Cisco Remote-PHY Solution, on page 51](#)
- [Configuration Example for the Cisco Remote-PHY Solution, on page 51](#)

Prerequisites for Configuring the Cisco Remote-PHY Solution

- The Cisco CMTS must have at least one DOCSIS Timing, Communication, and Control (DTCC) card configured in the DOCSIS Timing Interface (DTI) mode for the Cisco cBR RF line card to work with the Cisco Remote-PHY Compact Shelf.

Restrictions for Configuring the Cisco Remote-PHY Solution

- Adding or removing the upstream or downstream channels in the channel group may trigger the Cisco Remote-PHY Compact Shelf to reset.
- The Cisco cBR RF line card supports only static DEPI configuration.
- The Cisco cBR RF line card does not support Spectrum Management, Inter Line Card RF Spanning, and High Availability.

How to Configure the Cisco Remote-PHY Solution

For detailed instructions, see the Cisco Remote-PHY Configuration Guide.

Configuration Example for the Cisco Remote-PHY Solution

Cisco Remote-PHY RPD CM Online Basic Configuration Example

```
interface TenGigabitEthernet0/1/0
ip address 209.165.200.225 255.255.255.224
```

```

ip helper-address 209.165.200.226

cable downstream controller-profile 3
  rf-chan 0 31
  rf-output NORMAL
  type DOCSIS
  frequency 111000000
  qam-profile 1
  docsis-channel-id 1

cable upstream controller-profile 3
  us-channel 0 channel-width 3200000 3200000
  us-channel 0 docsis-mode atdma
  us-channel 0 frequency 11400000
  us-channel 0 minislots-size 2
  us-channel 0 modulation-profile 221
  no us-channel 0 shutdown
  us-channel 1 channel-width 3200000 3200000
  us-channel 1 docsis-mode atdma
  us-channel 1 frequency 14600000
  us-channel 1 minislots-size 2
  us-channel 1 modulation-profile 221
  no us-channel 1 shutdown
  us-channel 2 channel-width 3200000 3200000
  us-channel 2 docsis-mode atdma
  us-channel 2 frequency 17800000
  us-channel 2 minislots-size 2
  us-channel 2 modulation-profile 221
  no us-channel 2 shutdown
  us-channel 3 channel-width 3200000 3200000
  us-channel 3 docsis-mode atdma
  us-channel 3 frequency 21000000
  us-channel 3 minislots-size 2
  us-channel 3 modulation-profile 221
  no us-channel 3 shutdown
  us-channel 4 channel-width 3200000 3200000
  us-channel 4 docsis-mode atdma
  us-channel 4 frequency 24200000
  us-channel 4 minislots-size 2
  us-channel 4 modulation-profile 221
  no us-channel 4 shutdown
  us-channel 5 channel-width 3200000 3200000
  us-channel 5 docsis-mode atdma
  us-channel 5 frequency 27400000
  us-channel 5 minislots-size 2
  us-channel 5 modulation-profile 221
  no us-channel 5 shutdown

interface Cable0/0/0
  load-interval 30
  downstream Downstream-Cable 0/0/0 rf-channel 0-23
  upstream 0 Upstream-Cable 0/0/0 us-channel 0
  upstream 1 Upstream-Cable 0/0/0 us-channel 1
  upstream 2 Upstream-Cable 0/0/0 us-channel 2
  upstream 3 Upstream-Cable 0/0/0 us-channel 3
  upstream 4 Upstream-Cable 0/0/0 us-channel 4
  upstream 5 Upstream-Cable 0/0/0 us-channel 5
  cable upstream bonding-group 1
    upstream 0
    upstream 1
    upstream 2
    upstream 3
    attributes 80000001
  cable upstream bonding-group 2

```

```
upstream 2
upstream 3
upstream 4
upstream 5
attributes 80000001
cable upstream bonding-group 3
upstream 0
upstream 1
upstream 4
upstream 5
attributes 80000001
cable bundle 1
cable ip-init dual-stack

interface Wideband-Cable0/0/0:0
cable bundle 1
cable rf-channels channel-list 0-7 bandwidth-percent 10

interface Wideband-Cable0/0/0:1
cable bundle 1
cable rf-channels channel-list 8-15 bandwidth-percent 10

cable fiber-node 200
downstream Downstream-Cable 0/0/0
upstream Upstream-Cable 0/0/0

cable rpd node1
identifier 0004.9f03.0061
rpd-ds 0 base-power 42
core-interface Te0/1/0
rpd-ds 0 downstream-cable 0/0/0 profile 3
rpd-us 0 upstream-cable 0/0/0 profile 3
r-dti 1
rpd-event profile 0

interface Loopback1588
ip address 209.165.200.228 255.255.255.224
interface TenGigabitEthernet5/1/3 (connect to ASR903)
ip address 209.165.200.229 255.255.255.224

ip route 209.165.200.250 255.255.255.254 209.165.200.251 (route to ASR903 loopback ip)

ptp clock ordinary domain 0
servo tracking-type R-DTI
clock-port slave-from-903 slave
delay-req interval -4
sync interval -5
sync one-step
transport ipv4 unicast interface Lo1588 negotiation
clock source 209.165.200.250 (ASR903 loopback ip)

ptp r-dti 1
ptp-domain 0 (same domain number with ptp server)
clock-port 1
ethernet 1 (default value is same index with clock-port index, for RPD, ethernet 1=vbh0,
ethernet 2=vbh1)
clock-source 209.165.200.250 gateway 209.165.200.253 (clock-source is ASR903 loopback
ip, gateway is the RPD's next hop to access ASR903.)
```



CHAPTER 6

Monitoring the Cisco Remote-PHY Solution

- [Verifying the Cisco Remote-PHY Compact Shelf Using the CLI, on page 55](#)

Verifying the Cisco Remote-PHY Compact Shelf Using the CLI

To verify the Cisco RPD status and configuration, use the **show cable rpd group** command. For more information, see the [Cisco CMTS Cable Command Reference](#) guide.



CHAPTER 7

Monitoring the Interface Card in the Cisco cBR Chassis

- [Monitoring the Interface Line Cards in the Cisco cBR Chassis using LEDs, on page 57](#)
- [Monitoring the Digital Physical Interface Cards in the Cisco cBR Chassis using LEDs, on page 58](#)

Monitoring the Interface Line Cards in the Cisco cBR Chassis using LEDs

Table 14: Verifying the LEDs on the Interface Line Cards

LED	Status	Description
STATUS	Off	The line card has not initialized correctly.
	Yellow	The line card has initialized, but HA fault is detected. Possible hardware fault.
	Green	The line card is operational.
PROTECT	Off	The Interface line card is not a Protect card.
	Blue	The Interface line card is configured as a Protect card.
	Green	The Protect card is operational and traffic is flowing.
REPLACE	Off	The Interface line card is operational and does not require replacement.
	White	The Interface line card requires replacement.

Monitoring the Digital Physical Interface Cards in the Cisco cBR Chassis using LEDs

Table 15: Verifying the LEDs on the Cisco DPIC

LED	Status	Description
STATUS	Off	The card is not powered up.
	On	The card is operational.
10GE Link Status	Off	The specific link is down or the optical module is absent.
	On	The specific link is up.
REPLACE	Off	The card is operational and does not require replacement.
	On	The card requires replacement.



CHAPTER 8

Troubleshooting the Cisco Remote-PHY Solution

- [Troubleshooting: Cisco cBR-CCAP-LC-40G Line Card Link LED Does Not Illuminate, on page 59](#)
- [Troubleshooting: The Cisco cBR-CCAP-LC-40G Line Card is Not Working, on page 59](#)
- [Troubleshooting: The cable modems are not in init\(\) state, on page 60](#)

Troubleshooting: Cisco cBR-CCAP-LC-40G Line Card Link LED Does Not Illuminate

Problem After inserting the network cable into the SFP module of the Cisco cBR-CCAP-LC-40G line card, the LINK LED of the line card does not illuminate.

Possible Cause Dirt or skin oil is accumulated on the network cable plug faceplate generating significant attenuation and reducing the optical power levels below threshold levels. This could result in link failure.

Solution Clean the plug faceplate with a lint-free tissue soaked in 99 percent pure isopropyl alcohol and then with a dry lint-free tissue. Remove any residual dust from the faceplate with compressed air before installing the network cable.

Troubleshooting: The Cisco cBR-CCAP-LC-40G Line Card is Not Working

Problem The Cisco cBR-CCAP-LC-40G line card is not working.

Possible Cause The Cisco cBR-CCAP-LC-40G line card is not connected to the power supply.

Solution Verify if the power LED is illuminated and the power supply is connected to the Cisco cBR-CCAP-LC-40G line card. Connect to the power supply, if not connected.

Possible Cause The Cisco cBR-CCAP-LC-40G line card is not configured on the Cisco CMTS.

Solution Configure the Cisco cBR-CCAP-LC-40G line card.

Possible Cause The captive screws are not secured on the faceplate and the ejector levers are not properly closed.

Solution Close the ejector levers and tighten the captive screws with your fingers. Then, use either a T-10 Torx or a common flathead screwdriver to tighten the captive screws from 5 to 7 in-lbs.

Possible Cause The Cisco cBR-CCAP-LC-40G line card is not firmly seated in the chassis.

Solution Unscrew the top and bottom captive screws on the line card using a T-10 Torx driver tool or flathead screwdriver. Simultaneously pivot both ejector levers away from the line card to disengage the line card. Slide the line card partially out of the slot in the chassis and slide it back in until it is firmly seated in the chassis. Close the ejector levers and tighten the captive screws with your fingers. Then, use either a T-10 Torx or a common flathead screwdriver to tighten the captive screws from 5 to 7 in-lbs.

Possible Cause The network cable connectors are not properly seated in the ports on the Cisco cBR-CCAP-LC-40G line card and cables are broken.

Solution Verify if the cables are broken. Replace the cables, if broken and insert the network cable connector into the SFP module port until it clicks and locks into place to ensure proper seating..

Possible Cause Incorrect or inappropriate software license is configured on the Cisco cBR-CCAP-LC-40G line card.

Solution Reinstall or rehost the appropriate license on the Cisco cBR-CCAP-LC-40G line card.

Possible Cause Power on Self Test (POST) fails when the line card is installed in the chassis.

Solution Verify the power supply connection and if the problem persists, contact the Technical Assistance Center (TAC) for further assistance.

Troubleshooting: The cable modems are not in init() state

Problem The cable modems are not in init() state.

Possible Cause PTP is not aligned.

Solution Use the **show ptp clock running** command to check ptp clock state.

```

NG13#show ptp clock running
                PTP Ordinary Clock [Domain 0]
      State      Ports      Pkts sent      Pkts rcvd      Redundancy Mode
  PHASE_ALIGNED 1          1666420         5051243         Hot standby
                PORT SUMMARY

                PTP Master
  Name          Tx Mode    Role      Transport    State      Sessions    Port Addr
  slave-from-903 unicast  slave    Lo1588       Slave      1           10.90.3.93
    
```