



# Cisco Remote-PHY Solution Overview

- [Introduction, on page 1](#)
- [Benefits, on page 2](#)
- [Architecture Overview, on page 2](#)
- [Cisco Cable Modem Termination System, on page 3](#)
- [Cisco Remote-PHY Compact Shelf , on page 3](#)
- [Cisco CCAP RF Line Card for R-PHY, on page 10](#)
- [Cisco Digital Physical Interface Card, on page 10](#)

## Introduction

Driven by market evolution towards triple-play services, cable operators in emerging markets are seeking standardized and digital fiber-based solutions for economical and future proof access technologies. Much of the demand is driven by the need to provide higher bandwidth packet transport for Internet connectivity, video and voice services.

Data Over Cable Systems Interface Standard (DOCSIS®) is a standardized technology for services over cable and thus has strong interoperability between system providers. It also provides robust Quality of Service (QoS) methods, ensuring packet delivery during periods of network congestion. Traditionally, DOCSIS runs on linear fiber (or HFC) to provide service and is not naturally applicable for digital fiber. Cisco has bridged the gap by introducing a new access technology called the Remote-PHY.

### Existing Architecture

In the emerging markets, most triple-play consumers live in multi-tenant buildings (referred to as Multi Dwelling Units or MDU) with the number of residents usually being less than 500 residents per building or cluster. These buildings are typically served by fiber with one of several “final 100 meter” technologies installed in the buildings. These technologies include fiber, twisted pair, Ethernet, and coaxial. Cable operators have access to the cable in the building and use this cable for their services. Several technologies exist for enabling two-way services over cable. These include a number of proprietary and vendor-specific methods. However, a standards-based approach to using cable is typically preferred by operators, since this ensures vendor interoperability.

### Need for the Cisco Remote-PHY Solution

DOCSIS and EuroDOCSIS are standards that define two-way operation over a cable network. DOCSIS provides the necessary Quality of Service (QoS) tools for ensuring voice call connectivity during periods of

network congestion that are anticipated in triple-play networks. DOCSIS is a robust and mature technology for voice, video, and IP video services.

The Cisco Remote-PHY solution leverages existing IP technologies and deploys DOCSIS in remote field over digital fiber to enable two-way services over cable.

## Benefits

The Cisco Remote-PHY solution provides a cost-effective digital fiber-based DOCSIS solution that uses Metro Ethernet (MetroE) as the transmission network between the Cisco CMTS and the cable modem.

- Reduced investment cost including capital and operational expenditure.
- Reduced CMTS hardware complexity.
- No restriction on Converged Interconnect Network (CIN) network.
- Futureproof architecture. Easy to migrate as the hardware and control functions are on separate layers.
- End-to-end QoS assurance provided by DOCSIS.
- Support for all DOCSIS services.
- Support for existing DOCSIS network provisioning system.
- High access bandwidth.
- With deep fiber, the optical noise contribution to SNR is eliminated. As a result, the remote QAM modulator runs at higher orders of modulation as compared to a centralized QAM modulator.

## Architecture Overview

Modular Headend Architecture version 2 (MHA v2) is a set of specifications for the Cisco Remote-PHY solution. It uses digital fiber compatible baseband networking technology to drive the fiber portion of the HFC plant. The coaxial portion of the plant remains the same. The upstream and downstream PHY are located on the remote side and acts as the remote PHY system. The Cisco Remote-PHY Compact Shelf acts as the remote PHY system. It connects the digital fiber and the coaxial portions of the plant together. The remote PHY system resides near or in buildings and has both RFI and Gigabit Ethernet interfaces. It provides layer 1 PHY (downstream and upstream PHY) functionality, layer 2 MAC functionality, and layer 3 tunneling and forwarding support. The CMTS remains unchanged with the exception of the upstream and downstream PHY being moved to the remote PHY system. The Cisco RF line card installed in the Cisco CMTS does not have the RFI interfaces for downstream and upstream, instead, it has Gigabit Ethernet interfaces for both downstream and upstream.

Protocols that form this architecture include:

- Downstream External PHY Interface Decapsulation—Downstream External PHY Interface (DEPI) is a L2TPv3-based protocol defined for downstream DOCSIS MAC management and data packets decapsulation. It is unidirectional, that is, from CMTS to remote PHY system.

DEPI supports:

- IP/User Datagram Protocol (UDP)

- DOCSIS MPT Mode (D-MPT)/Packet Streaming Protocol (PSP)
- Upstream External PHY Interface Encapsulation—Upstream External PHY Interface (UEPI) is a L2TPv3-based protocol defined for upstream DOCSIS MAC management and data packets encapsulation. It is unidirectional, that is, from remote PHY system to CMTS.

UEPI:

- Does not support UDP
- Supports PSP mode only
- Supports multiple pseudowires for RNG/BW-REQ/SPECTRUM-MGMT/MAP
- GCP—Generic Control Protocol, sets up a control plane tunnel over a generic transport protocol such as TCP or UDP. GCP is used to program the remote PHY system upstream and downstream parameters from the CMTS. It is also used to control the remote PHY system.

GCP supports:

- TCP/UDP
- DS/US PHY configuration and CMC provisioning/configuration
- Register mode and type, length, value (TLV) mode
- Notification

## Cisco Cable Modem Termination System

The Cisco cBR converged broadband router acts as the Cable Modem Termination System (CMTS) core for the Cisco Remote-PHY architecture.

Following are its functions:

- Assigns downstream and upstream channels of the Cisco RF line card to the Cisco Remote-PHY Compact Shelf.
- Performs MAC classification, forwarding, and management functions.
- Handles the Cisco Remote-PHY Compact Shelf configuration and management.

For more information on the Cisco CMTS, go to [Cisco cBR Series Converged Broadband Routers](#) page.

## Cisco Remote-PHY Compact Shelf

Below are some of the features of the Cisco Remote-PHY Compact Shelf:

- Full spectrum DOCSIS 3.0 support
- Full spectrum DOCSIS 3.1 support
- Converged broadcast, narrowcast, and VOD video support

- Out of Band (OOB) signaling support
- Dual 10GBE SFP+ backhaul connectivity
- CCAP support
- Support of optical overlay architectures

**Figure 1: Cisco Remote-PHY Compact Shelf**

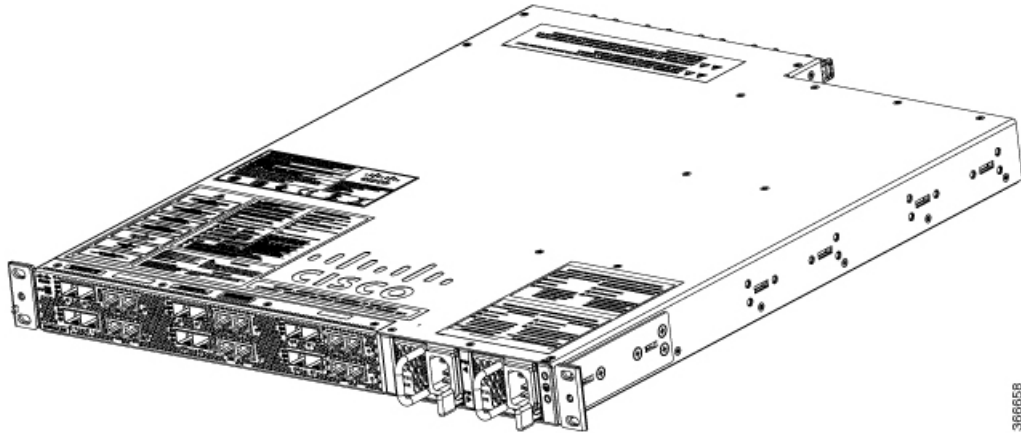

For the product described in this document both downstream and upstream PHY functionality is located in a shelf at the Headend, Hub or VHUB (Virtual Hub). The output of the Cisco Remote-PHY Compact Shelf feeds a conventional HFC network with optical nodes and RF amplifier cascades. The Cisco Remote-PHY Compact Shelf is intended to interact with the cBR-8 router, via a digital physical interface card (D-PIC) and the Cisco CCAP RF Line Card for Remote-PHY.

There are two models for Cisco Remote-PHY Compact Shelf: Cisco Remote-PHY Compact Shelf 6 x 12 and Cisco Remote-PHY Compact Shelf 3 x 6. They have the same functions, the only difference is the number of RPD modules integrated in the device. Cisco Remote-PHY Compact Shelf 6 x 12 has 6 RPD modules, Cisco Remote-PHY Compact Shelf 3 x 6 has 3 RPD modules.

## Front View

The following figure shows the front of the Cisco Remote-PHY Compact Shelf.

Figure 2: Cisco Remote-PHY Compact Shelf 6 x 12 Front View

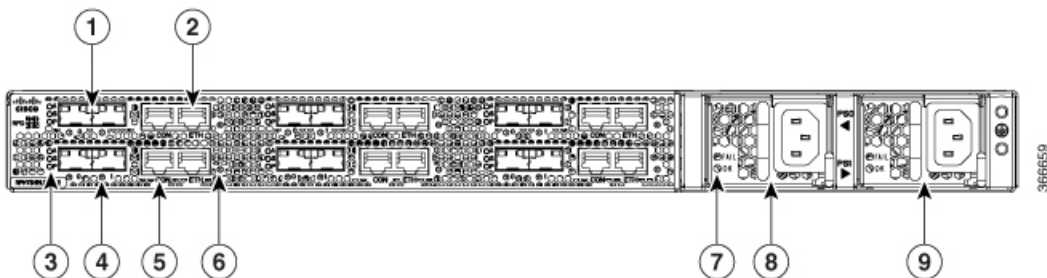
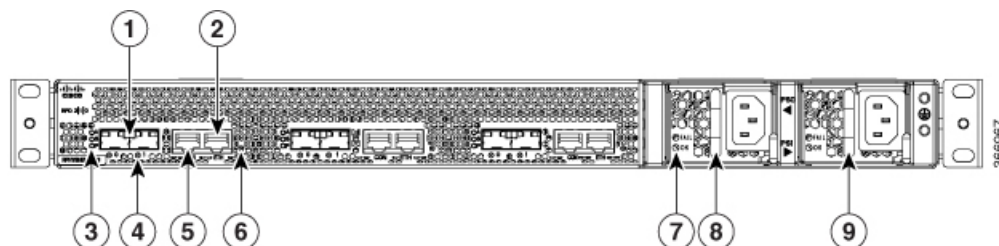

Figure 3: Cisco Remote-PHY Compact Shelf 3 x 6 Front View



1	0, 1 - 10GE SFP+ port	6	Management port LED
2	ETH - RJ-45 management port	7	Power supply LED
3	A, S, P - Alarm, Status, Power LED	8	PS0 – Power supply 0
4	SFP LED	9	PS1 – Power supply 1
5	CON - RJ-45/RS-232 compatible console port		

The following table shows the meaning of LED on the front panel of the Cisco Remote-PHY Compact Shelf.

Table 1: Cisco Remote-PHY Compact Shelf LEDs

No.	LED Label	Description	Behavior	Meaning
1	S	Status	Blinking	Normal.
2	P	Power	Green	Power on.
3	A	Alarm	Yellow	RPD module error, check the console logging.
4	SFP 0/1 LED	Link status	Green	Link is up.
5	ETH LED	Link status	Green	Link is up.

## Rear View

The following figure shows the rear of the Cisco Remote-PHY Compact Shelf.

**Figure 4: Cisco Remote-PHY Compact Shelf 6 x 12 Rear View**

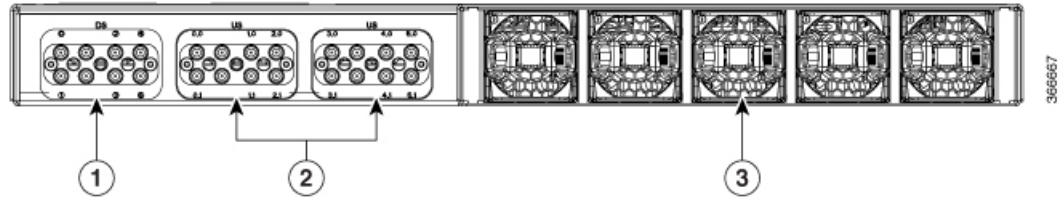

**Figure 5: Cisco Remote-PHY Compact Shelf 3 x 6 Rear View**

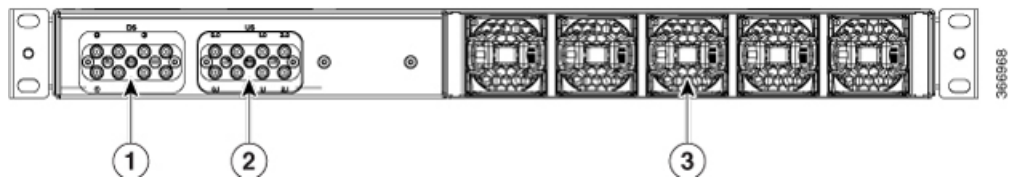

1	Downstream port cluster	3	Fans
2	Upstream port cluster		

The chassis has a front-to-rear airflow. Five internal fans draw cooling air into the chassis and across internal components to maintain an acceptable operating temperature. The fans are numbered from 1 to 5, right to left.

Two power supplies (AC or DC) are accessed from the front of the device and are hot-swappable.

## Power Supplies

The Cisco Remote-PHY Compact Shelf support AC or DC power supply options. The modular chassis configurations support the installation of two power supplies for redundancy, the current sharing feature is supported when two power supplies are installed in the system. When an external power supply fails or is removed, the other power supply provides power requirements for the chassis. This allows you to hot-swap the power supply without impacting the functionality of the device.



### Caution

Cisco Remote-PHY Compact Shelf can support two AC or two DC power supplies. Do not install mixed AC and DC power supply units in the same chassis.

The following table lists the power supplies that you can order:

Part Number	Power Supply
341-100761-01	Cisco Remote-PHY Compact Shelf DC Power Supply
341-100760-01	Cisco Remote-PHY Compact Shelf AC Power Supply

**Caution**

The chassis has a front-to-rear airflow. All of the power supplies and fan modules in the chassis must use the same airflow direction or an error will occur with possible overheating and shut down of the Cisco Remote-PHY Compact Shelf. If you power up the Cisco Remote-PHY Compact Shelf with more than one airflow direction, you must power down the Cisco Remote-PHY Compact Shelf and replace the modules with the wrong airflow direction before powering up the Cisco Remote-PHY Compact Shelf.

## AC Power Supply

The AC power supply input connector is IEC60320 C16, equipped with standard input AC power cord. The power supply has a handle to be used for insertion and extraction.

The following figure shows the Cisco Remote-PHY Compact Shelf AC power supply.

**Figure 6: AC Power Supply Used in the Cisco Remote-PHY Compact Shelf**

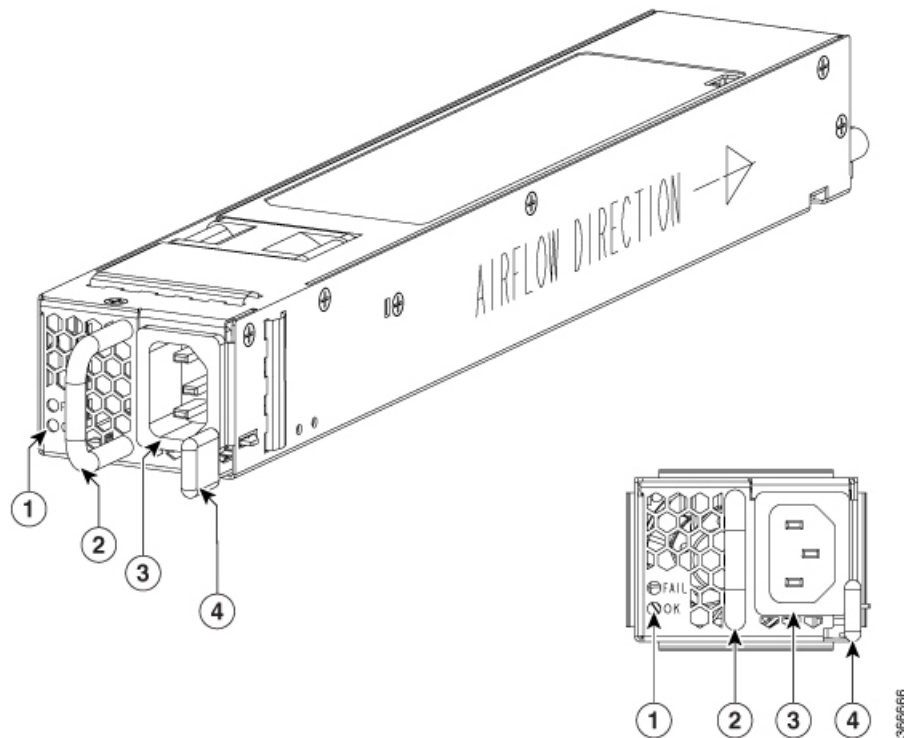

1	FAIL and OK LEDs	3	AC power connector
2	Handle	4	Retaining latch

## DC Power Supply

The DC power supply input connector is a two-wire connector with connection polarity from left to right (when facing the unit) of positive (+) negative (-).

The power supply has a handle to be used for insertion and extraction. The module must be supported with one hand when installing into or removing from Cisco Remote-PHY Compact Shelf.

The following figure shows the Cisco Remote-PHY Compact Shelf DC power supply.

**Figure 7: DC Power Supply Used in the Cisco Remote-PHY Compact Shelf**

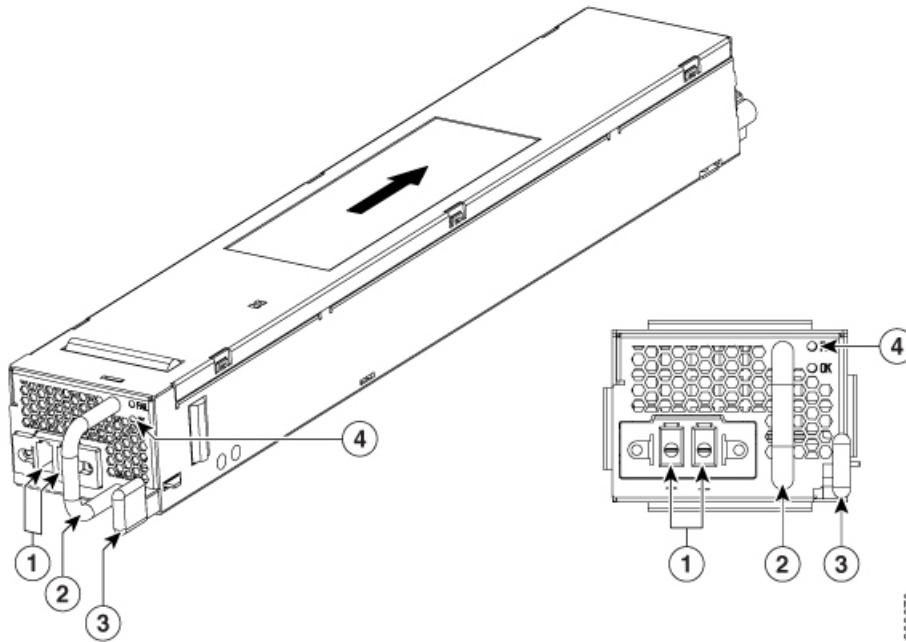

1	DC power connections	3	Retaining latch
2	Handle	4	FAIL and OK LEDs

## Power Supply LEDs

The following table describes the power supply LEDs.

**Table 2: AC and DC Power Supply LEDs**

Power Supply Condition	Green (OK) LED Status	Amber (FAIL) LED Status
No AC power to all power supplies	OFF	OFF
Power Supply Failure (includes over voltage, over current, over temperature and fan failure)	OFF	ON
Power Supply Warning events where the power supply continues to operate (high temperature, high power and slow fan)	OFF	1Hz Blinking
AC Present/3.3VSB on (PSU OFF)	1Hz Blinking	OFF
Power Supply ON and OK	ON	OFF



## Power Supply Fans

The fans in the power supply module are used for cooling the power supply module itself while system-level cooling is provided by fans within the chassis. The power supplies do not depend on the system-level fans for cooling. Fan failure is determined by fan-rotation sensors.



**Note** The fans in the power supply modules will run as soon as the power supply is plugged in.

## Power Cords

The following table lists the supported power cords.

Power Cord Item Number	Description
CAB-AC-ARG	Power Cord - Argentina, 10A, 250V, 2500mm, -40°C to +85°C
CAB-AC-AUS	Power Cord - Australia, 10A, 250V, 2500mm, -40°C to +85°C
CAB-AC-BRA	Power Cord - Brazil, 10A, 250V, 2500mm, -40°C to +85°C
CAB-AC-CHI	Power Cord - China, 10A, 250V, 2500mm, -40°C to +85°C
CAB-AC-EUR	Power Cord - Europe, 16/10A, 250V, 2500mm, -40°C to +85°C
CAB-AC-IND	Power Cord - India, 16/10A, 250V, 2500mm, -40°C to +85°C
CAB-AC-ISR	Power Cord - Israel, 16/10A, 250V, 2500mm, -40°C to +85°C
CAB-AC-ITL	Power Cord - Italy, 10A, 250V, 2500mm, -40°C to +85°C
CAB-AC-KOR	Power Cord - Korea, 16/10A, 125V, 2500mm, -40°C to +85°C
CAB-AC-SUI	Power Cord - Swiss, 10A, 250V, 2500mm, -40°C to +85°C
CAB-AC-TAI	Power Cord - Taiwan, 15/10A, 125V, 2500mm, -40°C to +85°C
CAB-AC-UK	Power Cord - UK, 13/10A, 250V, 2500mm, -40°C to +85°C
CAB-AC-US	Power Cord - US, 15A, 125V, 2500mm, -40°C to +85°C
PWR-CAB-AC-JPN	Power Cord for AC V2 Power Module (Japan)

## Fan Tray

The fan tray is a field replaceable unit which can be replaced on site when required.

Follow the steps below to replace a fan tray:

1. Pull out the fan tray for about 0.5 inch.
2. Wait for the fan blades are totally stopped.

**Danger**

Rotating fan blades can cause serious injury during fan tray removal or replacement.

3. Pull out the fan tray completely and replace it with a new fan tray.

## Cisco CCAP RF Line Card for R-PHY

The Cisco CCAP RF line card for remote PHY architecture is available in two flavours:

- CBR-LC-8D31-16U30—This RF line card with the downstream and upstream PHY modules can be connected with the Cisco Remote-PHY Compact Shelf by configuring it using the **card cBR-CCAP-LC-40G r-phy** command.
- CBR-CCAP-LC-40G-R—This RF line card with no downstream and upstream PHY modules can be connected with the Cisco Remote-PHY Compact Shelf.

## Cisco Digital Physical Interface Card

The Cisco Digital Physical Interface Card (DPIC) transmits and receives RF signals between the subscriber and headend over the hybrid fiber-coaxial (HFC) system and is DOCSIS-compliant. This interface card is designed specifically for the Cisco cBR router and conforms to the Integrated CMTS (I-CMTS) architecture. The PID is cBR-DPIC-8X10G.

The DPIC is installed in the CMTS and connected to the Cisco Remote-PHY Compact Shelf via the Metro Ethernet. It supports both downstream and upstream traffic. Both the downstream and upstream traffic share the same ports.

**Table 3: Physical Specifications of the DPIC**

Unit	Dimensions
Width	10.96 in (27.8cm)
Height	1.43 in (3.6cm)
Depth	7.32 in (18.6cm) with handle
Weight	2.943lb (1.335kg)

The DPIC supports:

- Eight ten gigabit ethernet SFP+ interfaces
- 80 gigabit non-blocking switching architecture with 40+40 protection scheme

- 40 gigabit DOCSIS traffic bandwidth when connected with the Cisco CBR-CCAP-LC-40G-R line card
- Cisco SFP-10G-SR-S/Cisco SFP-10G-LR-S/Cisco SFP-10G-ZR-S/Cisco SFP-10G-ER-S optic modules
- MACSec and 1588 TC

The faceplate of the Cisco DPIC has the following:

- Optic Cable Clip—Helps route and manage the optic cables.
- 8 x SFP+ ports—Used as 8 x 10GE lanes for DOCSIS traffic to the Cisco RPDs.
- 10GE Link Status LED—Indicates the status of the 10GE link.
- Status LED—Indicates the status of the Cisco DPIC.
- Replace LED—Indicates the Cisco DPIC must be replaced.

### Onboard Failure Logging

The Onboard Failure Logging (OBFL) feature enables the storage and collection of critical failure information in the nonvolatile memory of a Field Replaceable Unit (FRU), like a route processor (RP) or line card. The data stored through OBFL assists in understanding and debugging the field failures upon Return Material Authorization (RMA) of a RP or line card at repair and failure analysis sites. OBFL records operating temperatures, voltages, hardware uptime, and any other important events that assist board diagnosis in case of hardware failures.

For more information about the feature, see [Onboard Failure Logging](#).



---

**Note** The sample output provided in the [Onboard Failure Logging](#) guide may vary slightly for the Cisco CMTS routers.

---

