



## **Cisco Nexus 93180YC-FX3 ACI-Mode Switch Hardware Installation Guide**

**First Published:** 2021-02-01

**Last Modified:** 2023-03-01

### **Americas Headquarters**

Cisco Systems, Inc.  
170 West Tasman Drive  
San Jose, CA 95134-1706  
USA  
<http://www.cisco.com>  
Tel: 408 526-4000  
800 553-NETS (6387)  
Fax: 408 527-0883

THE SPECIFICATIONS AND INFORMATION REGARDING THE PRODUCTS REFERENCED IN THIS DOCUMENTATION ARE SUBJECT TO CHANGE WITHOUT NOTICE. EXCEPT AS MAY OTHERWISE BE AGREED BY CISCO IN WRITING, ALL STATEMENTS, INFORMATION, AND RECOMMENDATIONS IN THIS DOCUMENTATION ARE PRESENTED WITHOUT WARRANTY OF ANY KIND, EXPRESS OR IMPLIED.

The Cisco End User License Agreement and any supplemental license terms govern your use of any Cisco software, including this product documentation, and are located at: <http://www.cisco.com/go/softwareterms>. Cisco product warranty information is available at <http://www.cisco.com/go/warranty>. US Federal Communications Commission Notices are found here <http://www.cisco.com/c/en/us/products/us-fcc-notice.html>.

IN NO EVENT SHALL CISCO OR ITS SUPPLIERS BE LIABLE FOR ANY INDIRECT, SPECIAL, CONSEQUENTIAL, OR INCIDENTAL DAMAGES, INCLUDING, WITHOUT LIMITATION, LOST PROFITS OR LOSS OR DAMAGE TO DATA ARISING OUT OF THE USE OR INABILITY TO USE THIS MANUAL, EVEN IF CISCO OR ITS SUPPLIERS HAVE BEEN ADVISED OF THE POSSIBILITY OF SUCH DAMAGES.

Any products and features described herein as in development or available at a future date remain in varying stages of development and will be offered on a when-and if-available basis. Any such product or feature roadmaps are subject to change at the sole discretion of Cisco and Cisco will have no liability for delay in the delivery or failure to deliver any products or feature roadmap items that may be set forth in this document.

Any Internet Protocol (IP) addresses and phone numbers used in this document are not intended to be actual addresses and phone numbers. Any examples, command display output, network topology diagrams, and other figures included in the document are shown for illustrative purposes only. Any use of actual IP addresses or phone numbers in illustrative content is unintentional and coincidental.

The documentation set for this product strives to use bias-free language. For the purposes of this documentation set, bias-free is defined as language that does not imply discrimination based on age, disability, gender, racial identity, ethnic identity, sexual orientation, socioeconomic status, and intersectionality. Exceptions may be present in the documentation due to language that is hardcoded in the user interfaces of the product software, language used based on RFP documentation, or language that is used by a referenced third-party product.

Cisco and the Cisco logo are trademarks or registered trademarks of Cisco and/or its affiliates in the U.S. and other countries. To view a list of Cisco trademarks, go to this URL: [www.cisco.com go trademarks](http://www.cisco.com/go/trademarks). Third-party trademarks mentioned are the property of their respective owners. The use of the word partner does not imply a partnership relationship between Cisco and any other company. (1721R)

© 2021 Cisco Systems, Inc. All rights reserved.



## CONTENTS

---

### CHAPTER 1

#### Overview 1

Overview 1

---

### CHAPTER 2

#### Preparing the Site 7

Temperature Requirements 7

Humidity Requirements 7

Altitude Requirements 7

Dust and Particulate Requirements 8

Minimizing Electromagnetic and Radio Frequency Interference 8

Shock and Vibration Requirements 9

Grounding Requirements 9

Planning for Power Requirements 9

Airflow Requirements 10

Rack and Cabinet Requirements 11

Clearance Requirements 11

---

### CHAPTER 3

#### Installing the Switch Chassis 13

Safety 13

Installation Options with Rack-Mount Kits 16

Airflow Considerations 17

Installation Guidelines 17

Unpacking and Inspecting the Switch 18

Installing the Switch Using the NXK-ACC-KIT-1RU Rack-Mount Kit 18

Installing the Switch Using the N3K-C3064-ACC-KIT Rack-Mount Kit 22

Installing the Airflow Sleeve (N9K-AIRFLOW-SLV) 26

Grounding the Chassis 28

Starting the Switch 29

---

**CHAPTER 4**

**Connecting the Switch to the ACI Fabric 33**

ACI Fabric Topology 33

Preparing to Connect to Other Devices 34

Connecting Leaf Switches to APICs 35

Connecting Leaf Switches to Spine Switches 37

FEX Conversion and Support 38

Leaf to FEX Conversion 38

FEX to Leaf Conversion 39

New FEX Setup 39

Change an Existing Leaf in the Topology to FEX 39

Change an Existing FEX in the Topology to Leaf 39

Installing a Gigabit Ethernet module (GEM) 40

Migration of Nodes From a First Generation Switch to a Second Generation Switch 40

Setting Up an Optional Console Interface 42

Setting Up an Optional Management Connection 43

Maintaining Transceivers and Optical Cables 43

---

**CHAPTER 5**

**Replacing Components 45**

Replacing a Fan Module 45

Removing a Fan Module 45

Installing a Fan Module 46

Replacing a Power Supply Module 46

Replacing an AC Power Supply 46

---

**APPENDIX A**

**Rack Specifications 49**

Overview of Racks 49

General Requirements for Cabinets and Racks 49

Requirements Specific to Standard Open Racks 50

Requirements Specific to Perforated Cabinets 50

Cable Management Guidelines 50

---

**APPENDIX B**

**System Specifications 51**

Environmental Specifications	51
Switch Dimensions	51
Switch and Module Weights and Quantities	52
Transceiver and Cable Specifications	52
Switch Power Input Requirements	52
Power Specifications	53
650-W AC Power Supply Specifications	53
1200-W HVAC/HVDC Power Supply Specifications	53
930-W DC Power Supply Specifications	54
Power Cable Specifications	55
Power Cable Specifications for AC Power Supplies	55
HVAC/HVDC Power Cables Supported by ACI-Mode and NX-OS Mode Switches	56
DC Power Cable Specifications	57
Regulatory Standards Compliance Specifications	57

---

**APPENDIX C**    **LEDs**    **59**

Switch Chassis LEDs	59
Fan Module LEDs	60
Power Supply LEDs	60

---

**APPENDIX D**    **Additional Kits**    **63**

Rack Mount Kit NXK-ACC-KIT-1RU	63
Airflow Sleeve	64





# CHAPTER 1

## Overview

- [Overview, on page 1](#)

## Overview

The Cisco Nexus 93180YC-FX3 switch (N9K-C93180YC-FX3, N9K-C93180YC-FX3H) is a 1-rack unit (RU), fixed-port switch designed for spine-leaf-APIC deployment in data centers. This switch has the following ports:

- 48 100M/1/10/25-Gigabit Ethernet SFP28 ports (ports 1-48).
- 6 10/25/40/50/100-Gigabit QSFP28 ports (ports 49-54)
- One management port (one 10/100/1000BASE-T port)
- One console port (RS-232)
- 1 USB port

This switch includes the following user-replaceable components:

- Fan modules (four) with the following airflow choices:
  - Port-side exhaust fan module with blue coloring (NXA-FAN-35CFM-PE)
  - Port-side intake fan module with burgundy coloring (NXA-FAN-35CFM-PI)



**Note** *Table 1: Fan Speeds for This Switch*

	<b>Port-Side Intake Fan Speed %</b>	<b>Port-Side Exhaust Fan Speed %</b>
Typical/Minimum	50%	70%
Maximum	100%	100%



**Note** This switch runs with +1 redundancy mode, so that if one fan fails, the switch can sustain operation. But if a 2nd fan fails, this switch is not designed to sustain operation. Hence before waiting for major threshold temperature to be hit, the switch will power down due to **Powered-down due to fan policy trigger**.



**Note** Each fan module has two rotors. The switch can function normally if one rotor inside the any one fan module fails. In case of more than one rotor failure, the switch will issue a warning and power down in 2 minute.

- Power supply modules (two—One for operations and one for redundancy [1+1]) with the following choices:
  - 650-W port-side exhaust AC power supply with blue coloring (NXA-PAC-650W-PE)
  - 650-W port-side intake AC power supply with burgundy coloring (NXA-PAC-650W-PI)
  - 1200-W HVAC/HVDC power supply with dual-direction airflow white coloring (N9K-PUV-1200W)
  - 930-W port-side exhaust DC power supply with blue coloring (NXA-PDC-930W-PE)
  - 930-W port-side intake DC power supply with burgundy coloring (NXA-PDC-930W-PI)



**Note** All fan modules and power supplies must use the same airflow direction.



**Note** This switch may present access issues if installed between switches with greater chassis depth. Please consider this before installation.

**Deployment Scheme for SFP-10G-T-X Transceivers**

The following figure shows the maximum configuration density of SFP-10G-T-X SFP+ transceivers for this switch.

1	3	5	7	9	11	13	15	17	19	21	23	25	27	29	31	33	35	37	39	41	43	45	47	49	51	53
2	4	6	8	10	12	14	16	18	20	22	24	26	28	30	32	34	36	38	40	42	44	46	48	50	52	54

503038



Active Port deploying the SFP+ 10GBASE-T transceiver, with max power consumption up to 2.5W.  
 Once configured with “media-type 10g-tx” in NX-OS or “Link Level Policy -> Physical Media Type -> SFP 10G TX” in ACI, these ports can deploy SFP-10G-T-X. Without such configuration, they behave like normal ports.

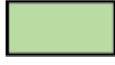

	<p>Port Shutdown or Active with Passive Copper Cables only (Max. power consumption up to 0.1W).</p> <p>Once 10g-tx is configured on yellow ports, ports to the left, right, top and bottom of the yellow port are referenced as blue ports. These adjacent ports will then support only low power Passive Copper DAC cable, or these can be left empty to conserve power. If 10g-tx configuration is removed from adjacent yellow ports, the blue ports will revert to behaving like normal ports.</p>
	<p>Active Port deploying any Cisco 1/10/25G optics (SFP, SFP+, SFP28) EXCLUDING SFP+ 10GBASE-T, with max power consumption up to 1.5W. These ports are not part of any scheme and can deploy all regular Cisco optics and behave like normal ports.</p>

The following figure shows the switch features on the port side of the chassis.

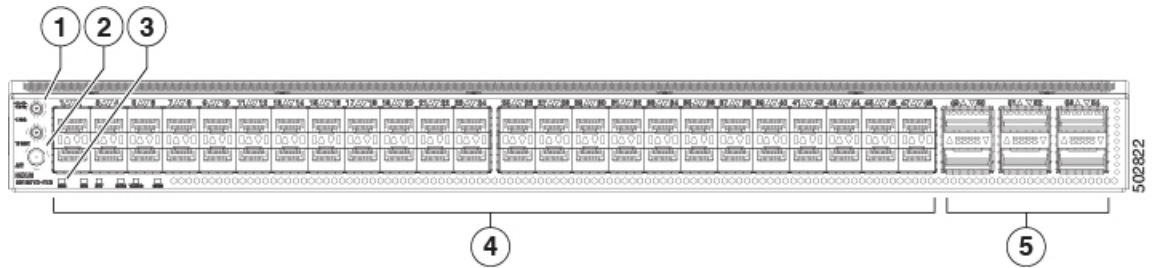

1	Ipps and 10MHz SMB ports	4	48 100M/1/10/25-Gigabit Ethernet SFP28 ports
2	GPS/GNSS antenna connector	5	6 10/25/40/50/100-Gigabit QSFP28 ports
3	LEDs		



**Note** Time of Day, and PTP GM is not supported

To determine which transceivers, adapters, and cables are support this switch, see the [Cisco Transceiver Modules Compatibility Information](#) document.

The following figure shows the switch features on the power supply side of the chassis.

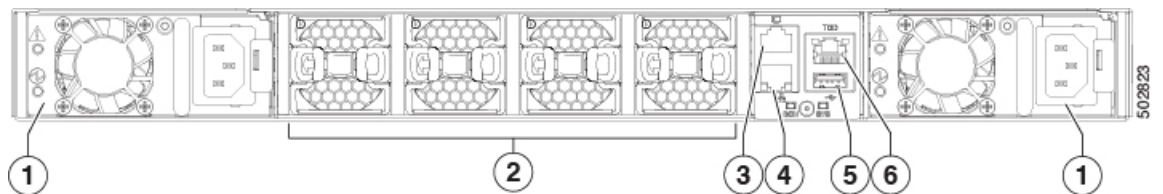

1	Power supply modules (1 or 2) (AC power supplies shown) with slots numbered 1 (left) and 2 (right)	4	Management port (RJ45)
2	Fan modules (4) with slots numbered from 1 (left) to 4 (right)	5	USB port
3	Console port	6	ToD port

**Table 2: ToD/1PPS RS422 Interface-RJ-45 Pinout**

Pin	Signal_name	Description
1	NC	No Connect
2	NC	No Connect
3	1PPS_N	1PPS RS422
4	GND	-
5	GND	-
6	1PPS_P	1PPS RS422
7	TOD_N	Time of Day (ToD) RS422
8	TOD_P	Time of Day (ToD) RS422

The following figure shows the side of the chassis.

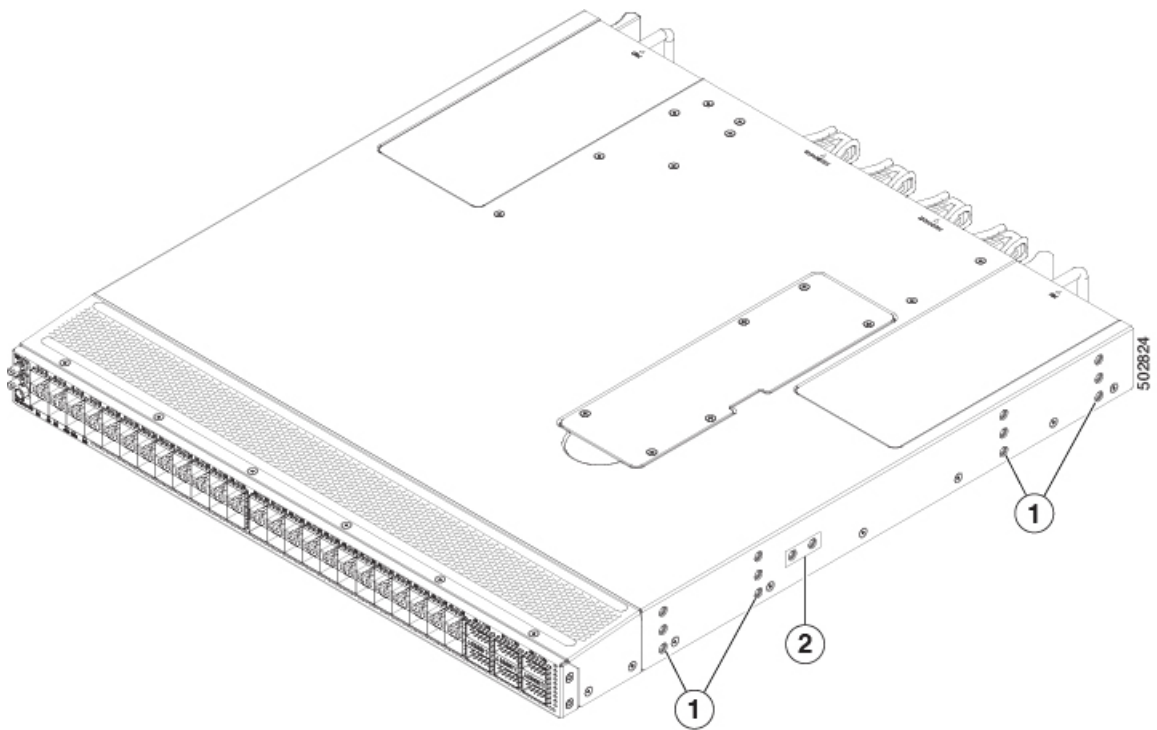

1	Screw holes for mounting brackets	3	Grounding pad
---	-----------------------------------	---	---------------

Depending on whether you plan to position the ports in a hot or cold aisle, you can order the fan and power supply modules with port-side intake or port-side exhaust airflow. For port-side intake airflow, the fan and power supplies have burgundy coloring. For port-side exhaust airflow, the fan and power supplies have blue coloring.

The fan and power supply modules are field replaceable. You can replace one fan module or one power supply module during operations so long as the other modules are installed and operating. If you have only one power supply installed, you can install the replacement power supply in the open slot before removing the original power supply.



---

**Note** All fan and power supply modules must have the same direction of airflow. Otherwise, the switch can overheat and shut down.

---



---

**Caution** If the switch has port-side intake airflow (burgundy coloring for fan modules), you must locate the ports in the cold aisle. If the switch has port-side exhaust airflow (blue coloring for fan modules), you must locate the ports in the hot aisle. If you locate the air intake in a hot aisle, the switch can overheat and shut down.

---





## CHAPTER 2

# Preparing the Site

---

- [Temperature Requirements, on page 7](#)
- [Humidity Requirements, on page 7](#)
- [Altitude Requirements, on page 7](#)
- [Dust and Particulate Requirements, on page 8](#)
- [Minimizing Electromagnetic and Radio Frequency Interference, on page 8](#)
- [Shock and Vibration Requirements, on page 9](#)
- [Grounding Requirements, on page 9](#)
- [Planning for Power Requirements, on page 9](#)
- [Airflow Requirements, on page 10](#)
- [Rack and Cabinet Requirements, on page 11](#)
- [Clearance Requirements, on page 11](#)

## Temperature Requirements

The switch requires an operating temperature of 32 to 104 degrees Fahrenheit (0 to 40 degrees Celsius). If the switch is not operating, the temperature must be between –40 to 158 degrees Fahrenheit (–40 to 70 degrees Celsius).

## Humidity Requirements

High humidity can cause moisture to enter the switch. Moisture can cause corrosion of internal components and degradation of properties such as electrical resistance, thermal conductivity, physical strength, and size. The switch is rated to withstand from 5- to 95-percent (nonoperating) and 5- to 90-percent (operating) relative humidity.

Buildings in which the climate is controlled by air-conditioning in the warmer months and by heat during the colder months usually maintain an acceptable level of humidity for the switch equipment. However, if the switch is located in an unusually humid location, use a dehumidifier to maintain the humidity within an acceptable range.

## Altitude Requirements

Altitude rating is 10,000 ft (3048 m). For China, it is 6,562 ft (2000 m).

## Dust and Particulate Requirements

Exhaust fans cool power supplies and system fans cool switches by drawing in air and exhausting air out through various openings in the chassis. However, fans also ingest dust and other particles, causing contaminant buildup in the switch and increased internal chassis temperature. Dust and particles can act as insulators and interfere with the mechanical components in the switch. A clean operating environment can greatly reduce the negative effects of dust and other particles.

In addition to keeping your environment free of dust and particles, follow these precautions to avoid contamination of your switch:

- Do not permit smoking near the switch.
- Do not permit food or drink near the switch.

## Minimizing Electromagnetic and Radio Frequency Interference

Electromagnetic interference (EMI) and radio frequency interference (RFI) from the switch can adversely affect other devices, such as radio and television (TV) receivers. Radio frequencies that emanate from the switch can also interfere with cordless and low-power telephones. Conversely, RFI from high-power telephones can cause spurious characters to appear on the switch monitor.

RFI is defined as any EMI with a frequency above 10 kHz. This type of interference can travel from the switch to other devices through the power cable and power source or through the air as transmitted radio waves. The Federal Communications Commission (FCC) publishes specific regulations to limit the amount of EMI and RFI that are emitted by computing equipment. Each switch meets these FCC regulations.

To reduce the possibility of EMI and RFI, follow these guidelines:

- Cover all open expansion slots with a blank filler plate.
- Always use shielded cables with metal connector shells for attaching peripherals to the switch.

When wires are run for any significant distance in an electromagnetic field, interference can occur to the signals on the wires with the following implications:

- Bad wiring can result in radio interference emanating from the plant wiring.
- Strong EMI, especially when it is caused by lightning or radio transmitters, can destroy the signal drivers and receivers in the chassis and even create an electrical hazard by conducting power surges through lines into equipment.



---

**Note** To predict and prevent strong EMI, you need to consult experts in radio frequency interference (RFI).

---

The wiring is unlikely to emit radio interference if you use a twisted-pair cable with a good distribution of grounding conductors. If you exceed the recommended distances, use a high-quality twisted-pair cable with one ground conductor for each data signal when applicable.

**Caution**

If the wires exceed the recommended distances, or if wires pass between buildings, give special consideration to the effect of a lightning strike in your vicinity. The electromagnetic pulse that is caused by lightning or other high-energy phenomena can easily couple enough energy into unshielded conductors to destroy electronic switches. You will want to consult experts in electrical surge suppression and shielding if you had similar problems in the past.

## Shock and Vibration Requirements

The switch has been shock- and vibration-tested for operating ranges, handling, and earthquake standards.

## Grounding Requirements

The switch is sensitive to variations in voltage that is supplied by the power sources. Overvoltage, undervoltage, and transients (or spikes) can erase data from memory or cause components to fail. To protect against these types of problems, ensure that there is an earth-ground connection for the switch. You can connect the grounding pad on the switch either directly to the earth-ground connection or to a fully bonded and grounded rack.

When you properly install the chassis in a grounded rack, the switch is grounded because it has a metal-to-metal connection to the rack. Alternatively, you can ground the chassis by using a customer-supplied grounding cable that meets your local and national installation requirements. For U.S. installations, we recommend 6-AWG wire. Connect your grounding cable to the chassis with a grounding lug (provided in the switch accessory kit) and to the facility ground.

**Note**

You automatically ground AC power supplies when you connect them to AC power sources. For DC power supplies, you must connect a grounding wire when wiring the power supply to the DC power source.

**Note**

An electrical conducting path shall exist between the product chassis and the metal surface of the enclosure or rack in which it is mounted or to a grounding conductor. Electrical continuity shall be provided by using thread-forming type mounting screws that remove any paint or non-conductive coatings and establish a metal-to-metal contact. Any paint or other non-conductive coatings shall be removed on the surfaces between the mounting hardware and the enclosure or rack. The surfaces shall be cleaned and an antioxidant applied before installation.

## Planning for Power Requirements

The switch includes two power supplies (1-to-1 redundancy with current sharing) in one of the following combinations:

- Two 650-W AC power supplies (NEBS compliant)
- Two 1200-W HVAC/HVDC power supplies

- Two 930-W DC power supplies



---

**Note** For 1+1 redundancy, you must use two power sources and connect each power supply to a separate power source.

---

The power supplies are rated to output up to 650 W (AC power supplies) but the switch requires less than that amount of power from the power supply. To operate the switch, you must provision enough power from the power source to cover the requirements of both the switch and a power supply. Typically, this switch and a power supply require 500 W of power input from the power source, but you must provision as much as 625 W of power input from the power source to cover peak demand.



---

**Note** Some of the power supply modules have rating capabilities that exceed the switch requirements. When calculating your power requirements, use the switch requirements to determine the amount of power that is required for the power supplies.

---

To minimize the possibility of circuit failure, make sure that each power-source circuit that is used by the switch is dedicated to the switch.



---

**Warning** **Statement 1033**—Safety Extra-Low Voltage (SELV)—IEC 60950/ES1—IEC 62368 DC Power Supply  
To reduce the risk of electric shock, connect the unit to a DC power source that complies with the SELV requirements in IEC 60950-based safety standards or ES1 and PS1 requirements in IEC 62368-based safety standards or to a Class 2 power supply.

---



---

**Note** We recommend 8-AWG wire for DC installations in the U.S.

---

## Airflow Requirements

The switch is positioned with its ports in either the front or the rear of the rack depending on your cabling and maintenance requirements.

To identify the airflow options for your switch, see the user-replaceable components in the *Overview* section of this document.

You must have fan and power supply modules that move the coolant air from the cold aisle to the hot aisle in one of the following ways:

- Port-side exhaust airflow—Cool air enters the chassis through the fan and power supply modules in the cold aisle and exhausts through the port end of the chassis in the hot aisle.
- Port-side intake airflow—Cool air enters the chassis through the port end in the cold aisle and exhausts through the fan and power supply modules in the hot aisle.

You can identify the airflow direction of each fan and power supply module by its coloring as follows:



- Blue coloring indicates port-side exhaust airflow.
- Burgundy coloring indicates port-side intake airflow.



---

**Note** To prevent the switch from overheating and shutting down, you must position the air intake for the switch in a cold aisle. The fan and power supply modules must have the same direction of airflow. If you must change the airflow direction for the switch, you must shutdown the switch before changing the modules.

---

## Rack and Cabinet Requirements

You can install the following types of racks or cabinets for your switch:

- Standard perforated cabinets
- Solid-walled cabinets with a roof fan tray (bottom-to-top cooling)
- Standard open four-post Telco racks

Work with your cabinet vendors to determine which of their cabinets meet the following requirements or see the Cisco Technical Assistance Center (TAC) for recommendations:

- Use a standard 19-inch (48.3-cm), four-post Electronic Industries Alliance (EIA) cabinet or rack with mounting rails that conform to English universal hole spacing per section 1 of the ANSI/EIA-310-D-1992 standard.
- The depth of a four-post rack must be 24 to 32 inches (61.0 to 81.3 cm) between the front and rear mounting rails (for proper mounting of the bottom-support brackets or other mounting hardware).

Also, you must have power receptacles that are located within reach of the power cords that are used with the switch.



---

**Warning** **Statement 1048**—Rack Stabilization

The rack stabilizing mechanism must be in place, or the rack must be bolted to the floor before installation or servicing. Failure to stabilize the rack can cause bodily injury.

---

## Clearance Requirements

Provide the chassis with adequate clearance between the chassis and any other rack, device, or structure so that you can properly install the chassis. Provide the chassis with adequate clearance to route cables, provide airflow, and maintain the switch. For the clearances required for an installation of this chassis in a four-post rack, see the following figure.

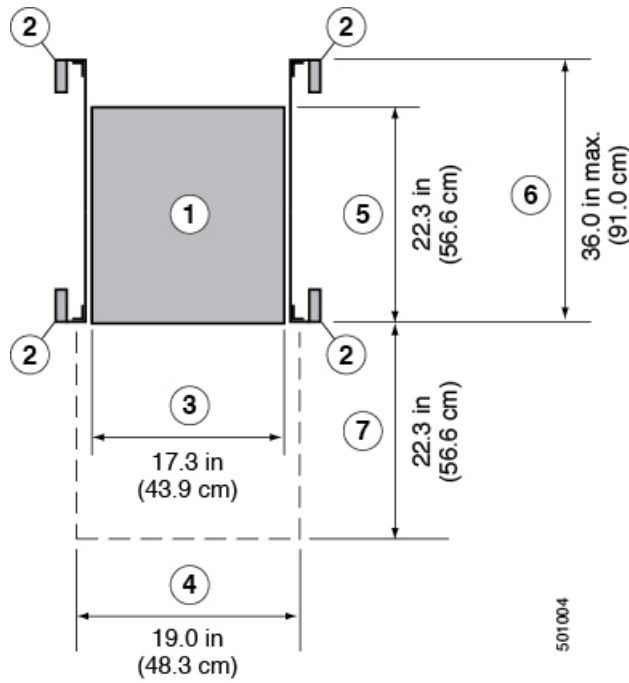

1	Chassis	5	Depth of the chassis
2	Vertical rack-mount posts and rails	6	Maximum extension of the bottom-support rails 36.0 in (91.0 cm)
3	Chassis width 17.3 in (43.9 cm)	7	Depth of the front clearance area (equal to the depth of the chassis).
4	Width of the front clearance area (equal to the width of the chassis with two rack-mount brackets that are attached to it). 19.0 in (48.3 cm)		



**Note** Both the front and rear of the chassis must be open to both aisles for airflow.



## CHAPTER 3

# Installing the Switch Chassis

---

- [Safety](#), on page 13
- [Installation Options with Rack-Mount Kits](#), on page 16
- [Airflow Considerations](#), on page 17
- [Installation Guidelines](#), on page 17
- [Unpacking and Inspecting the Switch](#), on page 18
- [Installing the Switch Using the NXK-ACC-KIT-1RU Rack-Mount Kit](#), on page 18
- [Installing the Switch Using the N3K-C3064-ACC-KIT Rack-Mount Kit](#), on page 22
- [Installing the Airflow Sleeve \(N9K-AIRFLOW-SLV\)](#), on page 26
- [Grounding the Chassis](#), on page 28
- [Starting the Switch](#), on page 29

## Safety

Before you install, operate, or service the switch, see the *Regulatory, Compliance, and Safety Information for the Cisco Nexus 3000 and 9000 Series* for important Safety Information.



---

**Warning** **Statement 1071**—Warning Definition

**IMPORTANT SAFETY INSTRUCTIONS**

Before you work on any equipment, be aware of the hazards involved with electrical circuitry and be familiar with standard practices for preventing accidents. Read the installation instructions before using, installing, or connecting the system to the power source. Use the statement number provided at the end of each warning statement to locate its translation in the translated safety warnings for this device.

**SAVE THESE INSTRUCTIONS**

---

**Warning Statement 1089**—Instructed and Skilled Person Definitions

An instructed person is someone who has been instructed and trained by a skilled person and takes the necessary precautions when working with equipment.

A skilled person or qualified personnel is someone who has training or experience in the equipment technology and understands potential hazards when working with equipment.

There are no serviceable parts inside. To avoid risk of electric shock, do not open.

**Warning Statement 1074**—Comply with Local and National Electrical Codes

To reduce risk of electric shock or fire, installation of the equipment must comply with local and national electrical codes.

**Note Statement 407**—Japanese Safety Instruction

You are strongly advised to read the safety instruction before using the product.

<https://www.cisco.com/web/JP/techdoc/pldoc/pldoc.html>

When installing the product, use the provided or designated connection cables/power cables/AC adapters.

〈製品仕様における安全上の注意〉  
www.cisco.com/web/JP/techdoc/index.html

接続ケーブル、電源コードセット、ACアダプタ、バッテリーなどの部品は、必ず添付品または指定品をご使用ください。添付品・指定品以外をご使用になると故障や動作不良、火災の原因となります。また、電源コードセットは弊社が指定する製品以外の電気機器には使用できないためご注意ください。

**Warning Statement 1017**—Restricted Area

This unit is intended for installation in restricted access areas. Only skilled, instructed, or qualified personnel can access a restricted access area.

**Warning Statement 1030**—Equipment Installation

Only trained and qualified personnel should be allowed to install, replace, or service this equipment.

**Warning Statement 1091**—Installation by an Instructed Person

Only an instructed person or skilled person should be allowed to install, replace, or service this equipment. See statement 1089 for the definition of an instructed or skilled person.

There are no serviceable parts inside. To avoid risk of electric shock, do not open.



---

**Warning Statement 1028—More Than One Power Supply**

This unit might have more than one power supply connection. To reduce risk of electric shock, remove all connections to de-energize the unit.

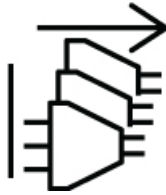

---

**Warning Statement 1003—Power Disconnection**

To reduce risk of electric shock or personal injury, disconnect DC power before removing or replacing components or performing upgrades.



---

**Warning Statement 1046—Installing or Replacing the Unit**

To reduce risk of electric shock, when installing or replacing the unit, the ground connection must always be made first and disconnected last.

If your unit has modules, secure them with the provided screws.



---

**Warning Statement 1022—Disconnect Device**

To reduce the risk of electric shock and fire, a readily accessible disconnect device must be incorporated in the fixed wiring.



---

**Warning Statement 1033—Safety Extra-Low Voltage (SELV)—IEC 60950/ES1—IEC 62368 DC Power Supply**

To reduce the risk of electric shock, connect the unit to a DC power source that complies with the SELV requirements in IEC 60950-based safety standards or ES1 and PS1 requirements in IEC 62368-based safety standards or to a Class 2 power supply.



---

**Warning Statement 1024—Ground Conductor**

This equipment must be grounded. To reduce the risk of electric shock, never defeat the ground conductor or operate the equipment in the absence of a suitably installed ground conductor. Contact the appropriate electrical inspection authority or an electrician if you are uncertain that suitable grounding is available.

---



---

**Warning** **Statement 1032**—Lifting the Chassis

To prevent personal injury or damage to the chassis, never attempt to lift or tilt the chassis using the handles on modules, such as power supplies, fans, or cards. These types of handles are not designed to support the weight of the unit.

---



---

**Warning** **Statement 1006**—Chassis Warning for Rack-Mounting and Servicing

To prevent bodily injury when mounting or servicing this unit in a rack, you must take special precautions to ensure that the system remains stable. The following guidelines are provided to ensure your safety:

- This unit should be mounted at the bottom of the rack if it is the only unit in the rack.
  - When mounting this unit in a partially filled rack, load the rack from the bottom to the top with the heaviest component at the bottom of the rack.
  - If the rack is provided with stabilizing devices, install the stabilizers before mounting or servicing the unit in the rack.
- 



---

**Caution** To prevent loss of input power, ensure the total maximum loads on the circuits supplying power to the switch are within the current ratings for the wiring and breakers.

---



---

**Note** For AC input application, please refer to the statement below:

---



---

**Warning** **Statement 1005**—Circuit Breaker

This product relies on the building's installation for short-circuit (overcurrent) protection. Ensure that the protective devices is rated not greater than 20A (North America), 16A (Europe), and 13A (UK).

---

## Installation Options with Rack-Mount Kits

The rack-mount kit enables you to install the switch into racks of varying depths. You can position the switch with easy access to either the port connections or the fan and power supply modules.

You can install the switch using the following rack-mount options:

- Rack-mount kit (NXX-ACC-KIT-1RU) which you can order from Cisco. This option offers you easy installation, greater stability, increased weight capacity, added accessibility, and improved removability with front and rear removal.
- Rack-mount kit (N3K-C3064-ACC-KIT) which you can order from Cisco.

The rack or cabinet that you use must meet the requirements listed in [General Requirements for Cabinets and Racks, on page 49](#) section.



---

**Note** You are responsible for verifying that your rack and rack-mount hardware comply with the guidelines that are described in this doc.

---

## Airflow Considerations

The switch comes with fan and power supply modules that have either port-side intake or port-side exhaust airflow for cooling the switch. If you are positioning the port end of the switch in a cold aisle, make sure that the switch has port-side intake fan modules with burgundy coloring. If you are positioning the fan and power supply modules in a cold aisle, make sure that the switch has port-side exhaust fan modules with blue colorings. All fan modules must have the same direction of airflow.

## Installation Guidelines

When installing the switch, follow these guidelines:

- Ensure that there is adequate clearance space around the switch to allow for servicing the switch and for adequate airflow.
- Ensure that the chassis can be adequately grounded. If the switch is not mounted in a grounded rack, we recommend connecting the system ground on the chassis directly to an earth ground.
- Ensure that the site power meets the power requirements for the switch. If available, you can use an uninterruptible power supply (UPS) to protect against power failures.



---

**Caution** Avoid UPS types that use ferroresonant technology. These UPS types can become unstable with the switch, which can have substantial current draw fluctuations because of fluctuating data traffic patterns.

---

- Ensure that circuits are sized according to local and national codes. Typically, this often requires one or both of the following:
  - AC power supplies typically require at least a 15-A or 20-A AC circuit, 100 to 240 VAC, and a frequency of 50 to 60 Hz.



---

**Caution** To prevent loss of input power, ensure the total maximum loads on the circuits supplying power to the switch are within the current ratings for the wiring and breakers.

---

# Unpacking and Inspecting the Switch

Before you install the switch, be sure to unpack and inspect the switch for damage or missing components. If anything is missing or damaged, contact your customer service representative immediately.



---

**Tip** Keep the shipping container in case the chassis requires shipping at a later time.

---

## Before you begin

Before you unpack the switch and before you handle any switch components, be sure that you are wearing a grounded electrostatic discharge (ESD) strap. To ground the strap, attach it directly to an earth ground or to a grounded rack or grounded chassis (there must be a metal-to-metal connection to the earth ground).

---

**Step 1** Compare the shipment to the equipment list provided by your customer service representative and verify that you have received all items, including the following:

- Accessory Kit

**Step 2** Check for damage and report any discrepancies or damage to your customer service representative. Have the following information ready:

- Invoice number of shipper (see packing slip)
  - Model and serial number of the damaged unit
  - Description of damage
  - Effect of damage on the installation
- 

# Installing the Switch Using the NXK-ACC-KIT-1RU Rack-Mount Kit

To install the switch, you must attach front and rear mounting brackets to the switch, install slider rails on the rear of the rack, slide the switch onto the slider rails, and secure the switch to the front of the rack. Typically, the front of the rack is the side easiest to access for maintenance.



---

**Note** You must supply the eight 10-32 or 12-24 screws required to mount the slider rails and switch to the rack.

---

## Before you begin

- You have inspected the switch shipment to ensure that you have everything ordered.



- Make sure that the switch rack-mount kit includes the following parts:
  - Front rack-mount brackets (2)
  - Rear rack-mount brackets (2)
  - Slider rails (2)
  - M4 x 0.7 x 8-mm Phillips pan-head screws (10)
- The rack is installed and secured to its location.

**Step 1**

Install two front rack-mount brackets and the two rear rack-mount brackets to the switch as follows:

a) Determine which end of the chassis is to be located in the cold aisle as follows:

- If the switch has port-side intake modules (fan modules with burgundy coloring), position the switch so that its ports will be in the cold aisle.
- If the switch has port-side exhaust modules (fan modules with blue coloring), position the switch so that its fan and power supply modules will be in the cold aisle.

b) Position the front rack-mount bracket and the rear rack-mount bracket so that its screw holes are aligned to the screw holes on the side of the chassis.

**Note** You can align the holes in the rack-mount bracket to the holes on the side of the chassis (see the two ways to mount these brackets on a typical chassis, in following figure). The holes that you use depend on the requirements of your rack and the amount of clearance required for interface cables (3 inches [7.6 mm] minimum) and module handles (1 inch [2.5 mm] minimum).

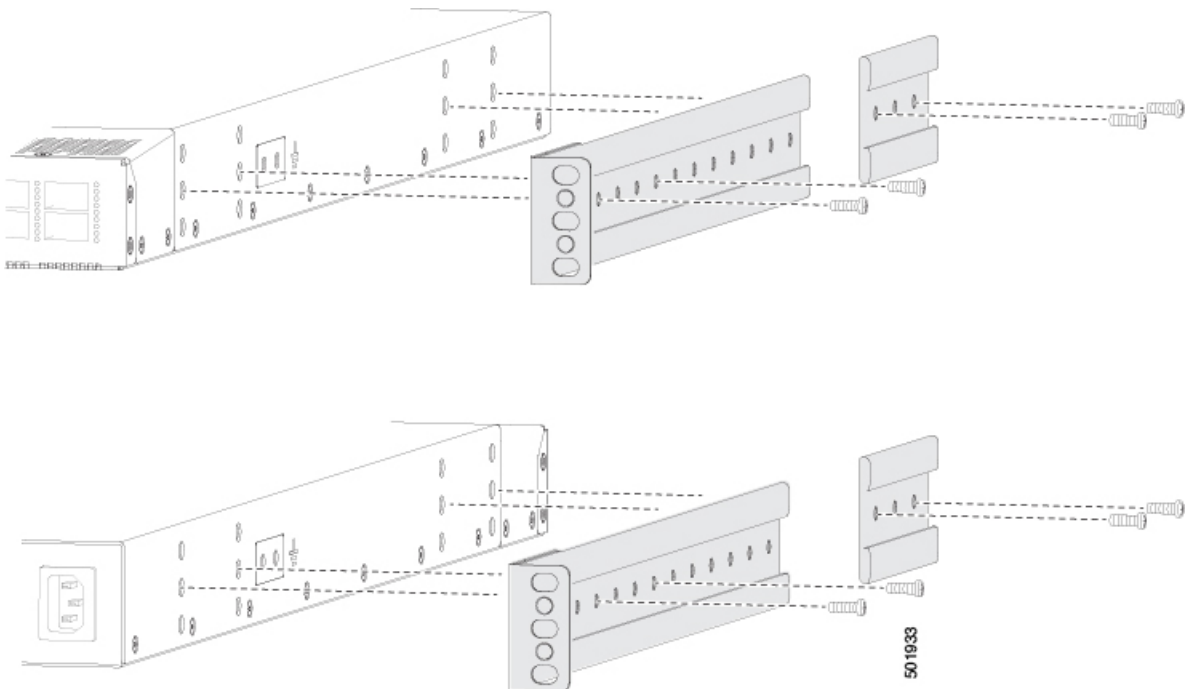

- c) Secure the front-mount bracket and the back-mount bracket to the chassis using four M4 screws and tighten each screw to 12 in-lb (1.36 N·m) of torque.
- d) Repeat Step 1 for the other front rack-mount bracket and the other back-mount bracket on the other side of the switch and be sure to position that bracket the same distance from the front of the switch.

**Note** Depending on the chassis depth, the back rack-mount bracket may not fit. In that case the back rack-mount bracket is not needed.

**Step 2** If you are not installing the chassis into a grounded rack, you must attach a customer-supplied grounding wire to the chassis as explained in the [Grounding the Chassis, on page 28](#) section. If you are installing the chassis into a grounded rack, you can skip this step.

**Step 3** Install the slider rails on the rack or cabinet as follows:

- a) Determine which two posts of the rack or cabinet you should use for the slider rails. Of the four vertical posts in the rack or cabinet, two will be used for the front mount brackets attached to the easiest accessed end of the chassis, and the other two posts will have the slider rails.
- b) Position a slider rail at the desired level on the back side of the rack and use 12-24 screws or 10-32 screws, depending on the rack thread type, to attach the rails to the rack (see the following figure). Tighten 12-24 screws to 30 in-lb (3.39 N·m) of torque and tighten 10-32 screws to 20 in-lb (2.26 N·m) of torque.

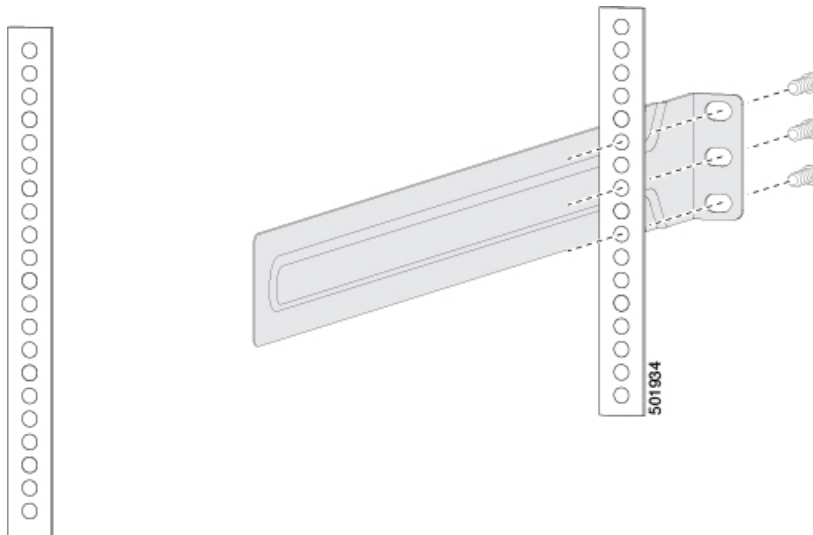

- c) Repeat Step 3 to attach the other slider rail to the other side of the rack.

To make sure that the slider rails are at the same level, you should use a level tool, tape measure, or carefully count the screw holes in the vertical mounting rails.

**Step 4** Insert the switch into the rack and attach it as follows:

- a) Holding the switch with both hands, position the two rear rack-mount brackets on the switch between the rack or cabinet posts that do not have slider rails attached to them (see the following figure).

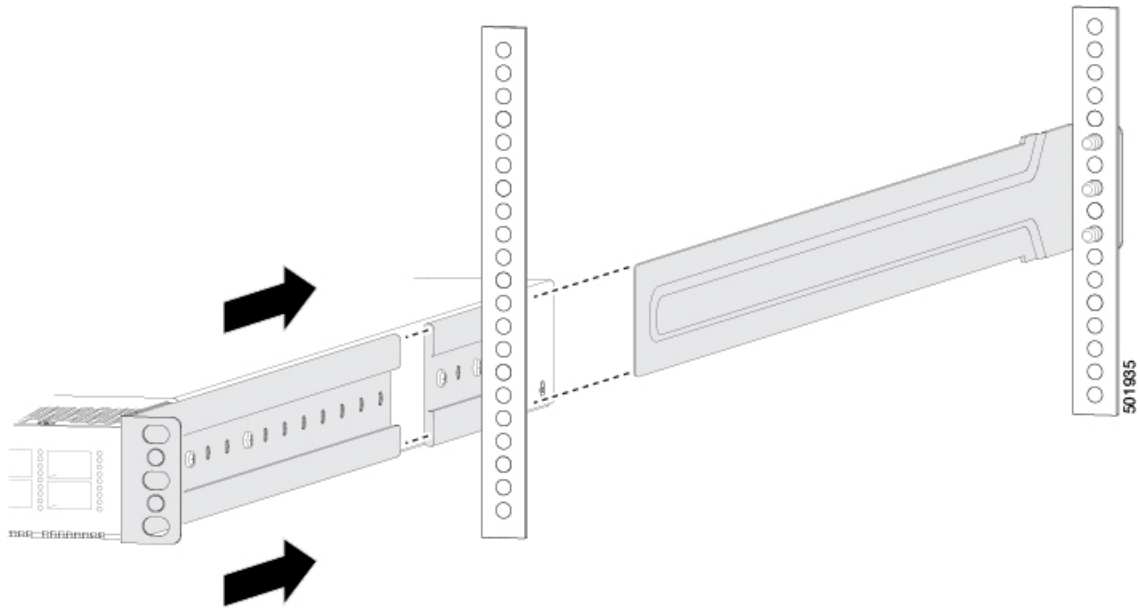

- b) Align the two rear rack-mount guides on either side of the switch with the slider rails installed in the rack. Slide the rack-mount guides onto the slider rails, and then gently slide the switch all the way into the rack until the front rack-mount brackets come in contact with two rack or cabinet posts.
- c) Holding the chassis level, insert screws (12-24 or 10-32, depending on the rack type) in each of the two front rack-mount brackets (using a total of six screws) and into the cage nuts or threaded holes in the vertical rack-mounting rails (see the following figure).

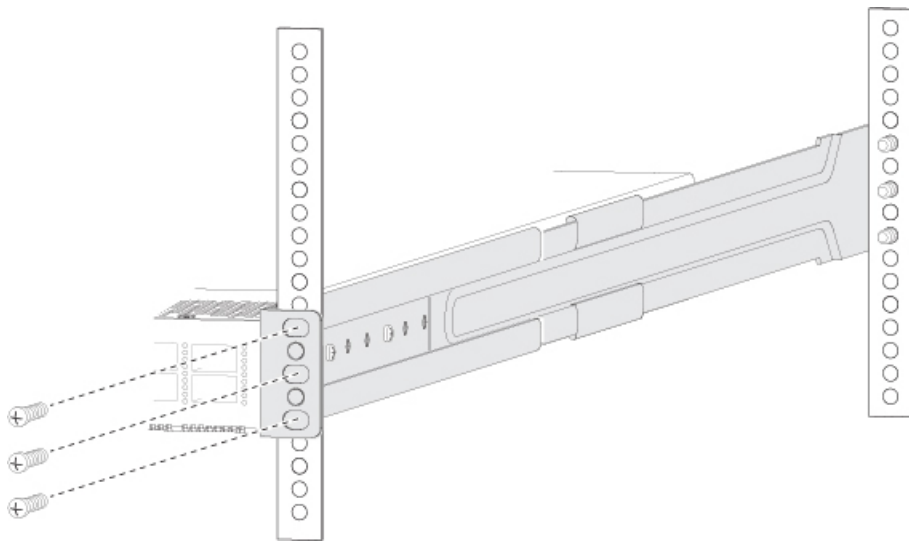

- d) Tighten the 10-32 screws to 20 in-lb (2.26 N·m) or tighten the 12-24 screws to 30 in-lb (3.39 N·m).

### Step 5

If you attached a grounding wire to the chassis grounding pad, connect the other end of the wire to the facility ground.

# Installing the Switch Using the N3K-C3064-ACC-KIT Rack-Mount Kit

To install the switch, you must attach front and rear mounting brackets to the switch, install slider rails on the rear of the rack, slide the switch onto the slider rails, and secure the switch to the front of the rack. Typically, the front of the rack is the side easiest to access for maintenance.



---

**Note** You must supply the eight 10-32 or 12-24 screws required to mount the slider rails and switch to the rack.

---

## Before you begin

- You have inspected the switch shipment to ensure that you have everything ordered.
- Make sure that the switch rack-mount kit includes the following parts:
  - Front rack-mount brackets (2)
  - Rear rack-mount brackets (2)
  - Slider rails (2)
  - M4 x 0.7 x 8-mm Phillips countersink screws (12)
- The rack is installed and secured to its location.

---

## Step 1

Install two front-mount brackets to the switch as follows:

a) Determine which end of the chassis is to be located in the cold aisle as follows:

- If the switch has port-side intake modules (fan modules with burgundy coloring), position the switch so that its ports will be in the cold aisle.
- If the switch has port-side exhaust modules (fan modules with blue coloring), position the switch so that its fan and power supply modules will be in the cold aisle.

b) Position a front-mount bracket so that four of its screw holes are aligned to the screw holes on the side of the chassis.

**Note** You can align any four of the holes in the front rack-mount bracket to four of the six screw holes on the side of the chassis (see the two ways to mount these brackets on a typical chassis, in following figure). The holes that you use depend on the requirements of your rack and the amount of clearance required for interface cables (3 inches [7.6 mm] minimum) and module handles (1 inch [2.5 mm] minimum).

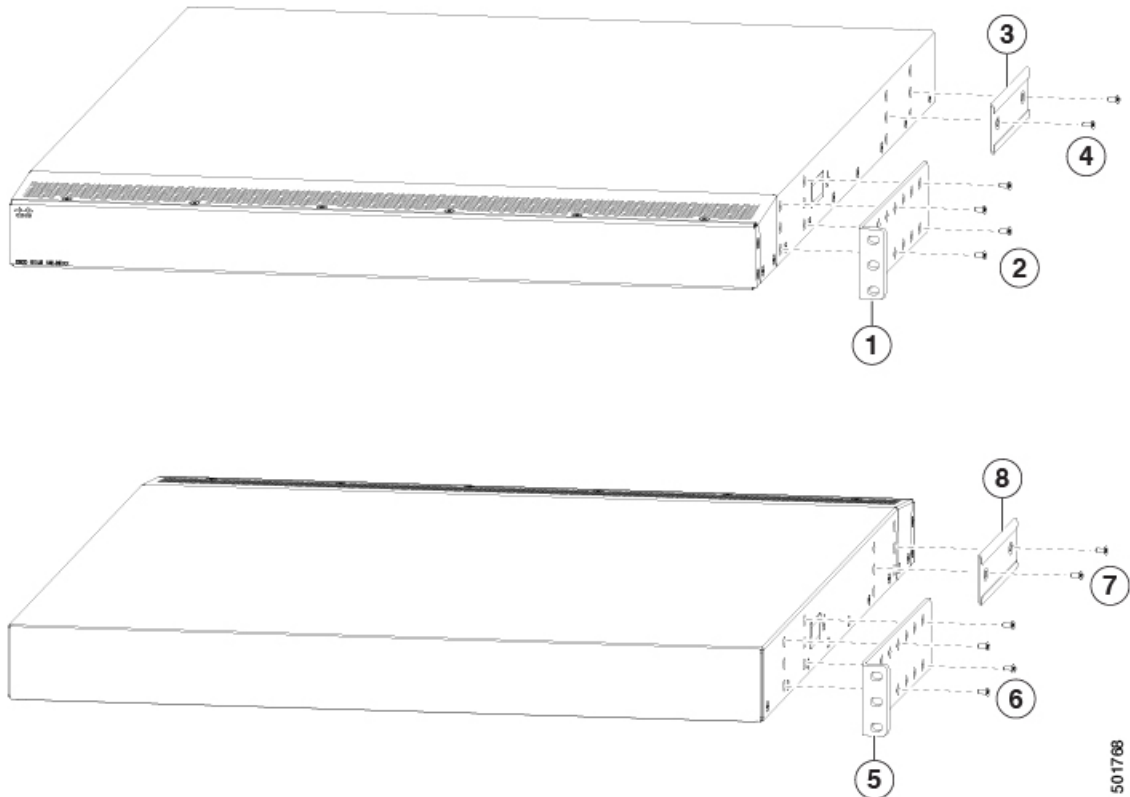

1	Front rack-mount bracket aligned to the port end of the chassis	5	Front rack-mount bracket aligned to the module end of the chassis
2	Four M4 screws used to attach the bracket to the chassis	6	Four M4 screws used to attach the bracket to the chassis
3	Rear rack-mount guide aligned to the module end of the chassis	7	Two M4 screws used to attach the bracket to the chassis
4	Two M4 screws used to attach the bracket to the chassis	8	Rear rack-mount guide aligned to the port end of the chassis

- c) Secure the front-mount bracket to the chassis using four M4 screws and tighten each screw to 12 in-lb (1.36 N·m) of torque.
- d) Repeat Step 1 for the other front rack-mount bracket on the other side of the switch and be sure to position that bracket the same distance from the front of the switch.

**Step 2** Install the two rear rack-mount brackets on the chassis as follows:

- a) Align the two screw holes on a rear rack-mount bracket to the middle two screw holes in the remaining six screw holes on a side of the chassis. If you are aligning the guide to holes that are near the port connections end of the chassis, see Callout 3 in the previous figure. Otherwise, see Callout 7 in the previous figure.
- b) Attach the guide to the chassis using two M4 screws (see Callout 4 or 8 in the previous figure). Tighten the screws to 12 in-lb (1.36 N·m) of torque.
- c) Repeat Step 2 for the other rear rack-mount bracket on the other side of the switch.

**Step 3** If you are not installing the chassis into a grounded rack, you must attach a customer-supplied grounding wire to the chassis as explained in the [Grounding the Chassis, on page 28](#) section.. If you are installing the chassis into a grounded rack, you can skip this step.

**Step 4** Install the slider rails on the rack or cabinet as follows:

- a) Determine which two posts of the rack or cabinet you should use for the slider rails. Of the four vertical posts in the rack or cabinet, two will be used for the front mount brackets attached to the easiest accessed end of the chassis, and the other two posts will have the slider rails.
- b) Position a slider rail at the desired level on the back side of the rack and use two 12-24 screws or two 10-32 screws, depending on the rack thread type, to attach the rails to the rack (see the following figure). Tighten 12-24 screws to 30 in-lb (3.39 N·m) of torque and tighten 10-32 screws to 20 in-lb (2.26 N·m) of torque.

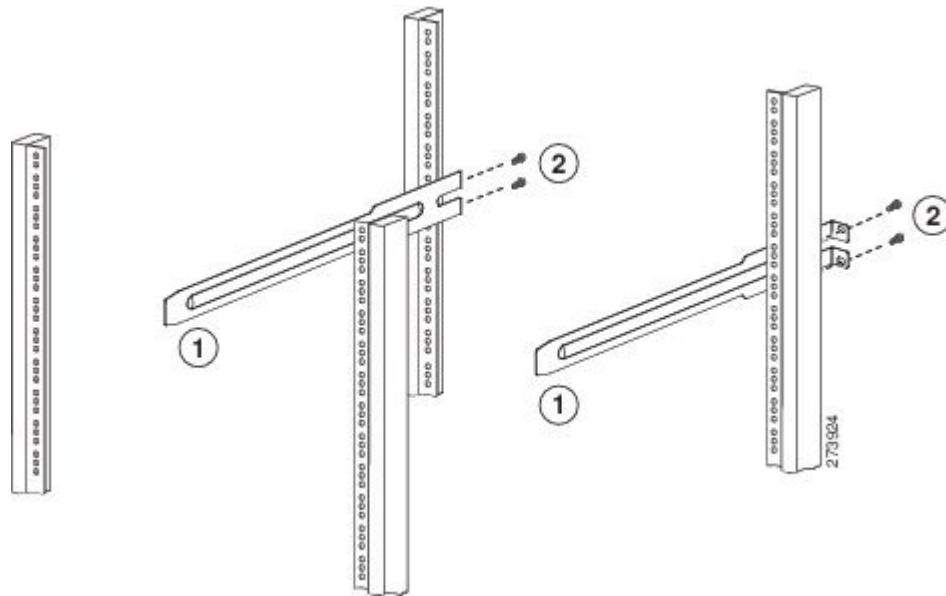

1	Slider rail with screw holes aligned to screw holes in rack	2	Two customer-supplied 12-24 or 10-32 screws used to attach each slider rail to the rack
---	---	---	---

- c) Repeat Step 3 to attach the other slider rail to the other side of the rack.

To make sure that the slider rails are at the same level, you should use a level tool, tape measure, or carefully count the screw holes in the vertical mounting rails.

**Step 5** Insert the switch into the rack and attach it as follows:

- a) Holding the switch with both hands, position the two rear rack-mount brackets on the switch between the rack or cabinet posts that do not have slider rails attached to them (see the following figure).

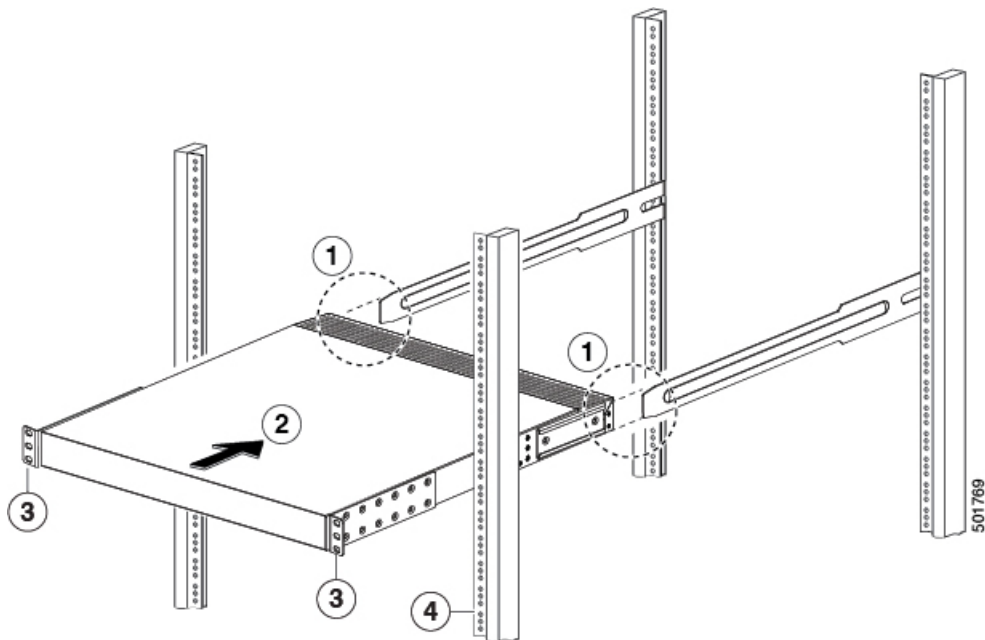

1	Align the two rear rack-mount bracket guides with the slider rails installed in the rack.	3	Front-mount brackets.
2	Slide the rack-mount guides onto the slider rails until the front rack-mount brackets come in contact with the front rack-mount rails.	4	Mounting rails on rack or cabinet posts.

- b) Align the two rear rack-mount guides on either side of the switch with the slider rails installed in the rack. Slide the rack-mount guides onto the slider rails, and then gently slide the switch all the way into the rack until the front rack-mount brackets come in contact with two rack or cabinet posts.
- c) Holding the chassis level, insert two screws (12-24 or 10-32, depending on the rack type) in each of the two front rack-mount brackets (using a total of four screws) and into the cage nuts or threaded holes in the vertical rack-mounting rails (see the following figure).

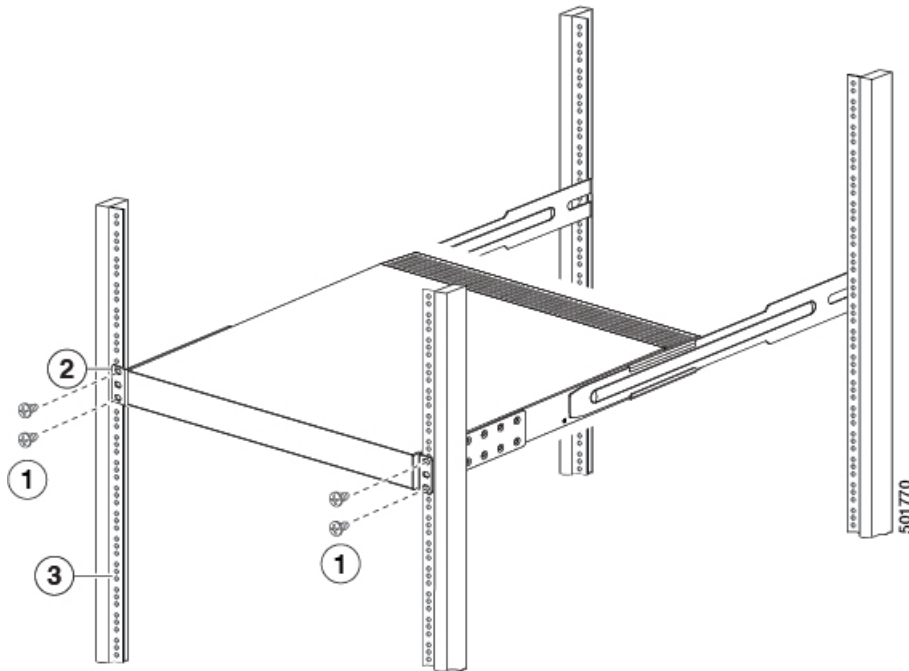

1	Fasten the chassis to the front of the rack with two 12-24 or 10-32 screws on each side.	3	Mounting rails on rack or cabinet posts.
2	Front-mount bracket.		

d) Tighten the 10-32 screws to 20 in-lb (2.26 N·m) or tighten the 12-24 screws to 30 in-lb (3.39 N·m).

**Step 6** If you attached a grounding wire to the chassis grounding pad, connect the other end of the wire to the facility ground.

## Installing the Airflow Sleeve (N9K-AIRFLOW-SLV)

The airflow sleeve (N9K-AIRFLOW-SLV) is installed to allow proper airflow, so that the switch is properly cooled. This airflow sleeve is only compatible with rack mount kit (N3K-C3064-ACC-KIT).

**Table 3: Airflow Sleeve (N9K-AIRFLOW-SLV) Minimum and Maximum Rack Rail Depth.**

Chassis	Minimum Rack Depth	Maximum Rack Depth
N9K-C92348GC-X	636.49 mm	748.25 mm
N9K-C9316D-GX	824.80 mm	916.60 mm
N9K-C9332C	794.20 mm	898.70 mm
N9K-C9332D-GX2B	824.00 mm	915.80 mm
N9K-C9336C-FX2	802.39 mm	903.98 mm



Chassis	Minimum Rack Depth	Maximum Rack Depth
N9K-C9336C-FX2-E	806.90 mm	898.70 mm
N9K-C9348GC-FXP	672.49 mm	764.29 mm
N9K-C93108TC-FX	781.29 mm	873.09 mm
N9K-C93108TC-FX3P	672.49 mm	769.69 mm
N9K-C93180YC-FX	781.29 mm	873.09 mm
N9K-C93180YC-FX3	672.49 mm	784.25 mm
N9K-C93180YC-FX3S	672.49 mm	784.25 mm
N9K-C93600CD-GX	824.80 mm	916.60 mm



**Note** You supply the screws to mount the airflow sleeve.

#### Before you begin

- Verify that your shipment is complete.
- Install your rack in a secure location.

Insert the airflow sleeve into the rack and attach it as follows:

- Holding the airflow sleeve (N9K-AIRFLOW-SLV) with both hands, position it in front of the fan side of the chassis.
- Holding the airflow sleeve level, insert screws (12-24 or 10-32, depending on the rack type) in each of the two front rack-mount flanges (using a total of two screws) and into the cage nuts or threaded holes in the vertical rack-mounting rails (see the following figure).

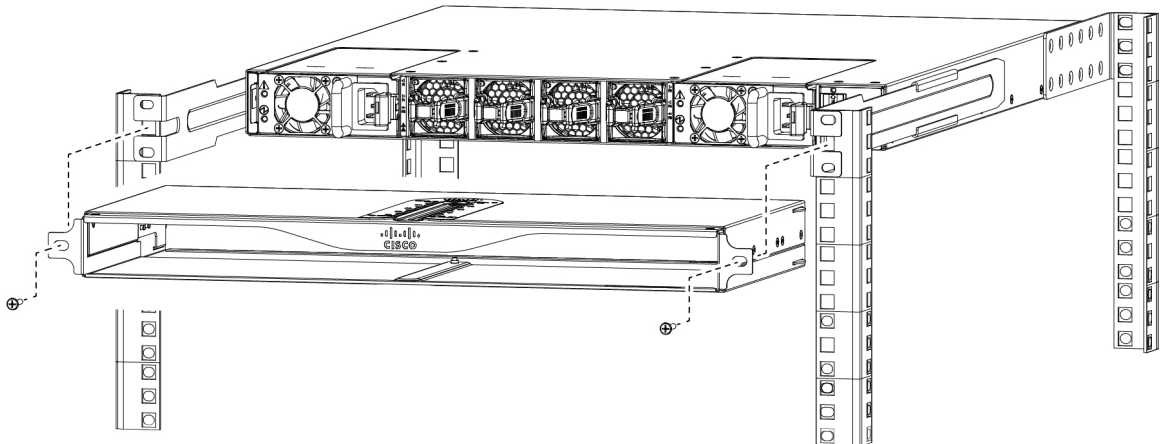

- Tighten the 10-32 screws to 20 in-lb (2.26 N·m) or tighten the 12-24 screws to 30 in-lb (3.39 N·m).

# Grounding the Chassis

The switch chassis is automatically grounded when you properly install the switch in a grounded rack with metal-to-metal connections between the switch and rack.



---

**Note** An electrical conducting path shall exist between the product chassis and the metal surface of the enclosure or rack in which it is mounted or to a grounding conductor. Electrical continuity shall be provided by using thread-forming type mounting screws that remove any paint or non-conductive coatings and establish a metal-to-metal contact. Any paint or other non-conductive coatings shall be removed on the surfaces between the mounting hardware and the enclosure or rack. The surfaces shall be cleaned and an antioxidant applied before installation.

---

You can also ground the chassis, which is required if the rack is not grounded, by attaching a customer-supplied grounding cable. Attach the cable to the chassis grounding pad and the facility ground.



---

**Warning** **Statement 1024**—Ground Conductor

This equipment must be grounded. To reduce the risk of electric shock, never defeat the ground conductor or operate the equipment in the absence of a suitably installed ground conductor. Contact the appropriate electrical inspection authority or an electrician if you are uncertain that suitable grounding is available.

---



---

**Warning** **Statement 1046**—Installing or Replacing the Unit

To reduce risk of electric shock, when installing or replacing the unit, the ground connection must always be made first and disconnected last.

---

## Before you begin

Before you can ground the chassis, you must have a connection to the earth ground for the data center building.

- 
- Step 1** Use a wire-stripping tool to remove approximately 0.75 inch (19 mm) of the covering from the end of the grounding wire. We recommend 6-AWG wire for the U.S. installations.
- Step 2** Insert the stripped end of the grounding wire into the open end of the grounding lug. Use a crimping tool to crimp the lug to the wire, see the following figure. Verify that the ground wire is securely attached to the grounding lug by attempting to pull the wire out of the crimped lug.

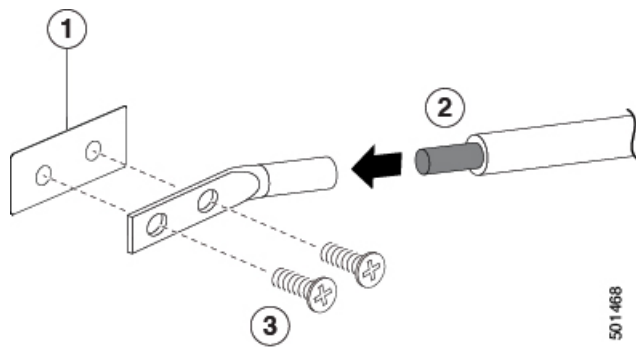

1	Chassis grounding pad	3	2 M4 screws are used to secure the grounding lug to the chassis
2	Grounding cable, with 0.75 in. (19 mm) of insulation that is stripped from one end, which is inserted into the grounding lug and crimped in place		

**Step 3** Secure the grounding lug to the chassis grounding pad with two M4 screws, see the previous figure. Tighten the screws to 11 to 15 in-lb (1.24 to 1.69 N·m) of torque.

**Step 4** Prepare the other end of the grounding wire and connect it to the facility ground.

## Starting the Switch

You start the switch by connecting it to its dedicated power source. If you need  $n+n$  redundancy, you must connect each power supply in a switch to a different power source.



**Note** This equipment is designed to boot up in less than 30 minutes, dependent on its neighboring devices being fully up and running.

### Before you begin

- The switch must be installed and secured to a rack or cabinet.
- The switch must be adequately grounded.
- The rack must be close enough to the dedicated power source so that you can connect the switch to the power source by using a designated power cables.
- You have the designated power cables for the power supplies that you are connecting to the dedicated power sources.



**Note** Depending on the outlet receptacle on your AC power distribution unit, you might need an optional jumper power cord to connect the switch to your outlet receptacle.

- The switch is not connected to the network (this includes any management or interface connections).
- The fan and power supply modules are fully secured in their chassis slots.

---

**Step 1** For any AC power supply, do the following:

- a) Using the recommended AC power cable for your country or region, connect one end to the AC power supply.
- b) Connect the other end of the power cable to the AC power source.

**Step 2** For any HVAC/HVDC power supply, connect it to a power source as follows:

- a) Using the recommended high voltage power cable for your country or region, connect the Anderson Power Saf-D-Grid connector on the power cable to the power receptacle on the power supply. Make sure that the connector clicks when fully pushed into the receptacle.
- b) Connect the other end of the power cable to a power source.
  - When connecting to an HVAC power source, insert the C14 or LS-25 plug in a receptacle for the HVAC power source.
  - When connecting to an HVDC power source, do the following:
    1. Verify that the power is turned off at a circuit breaker for the power source terminals.
    2. Remove the nuts from each of the terminal posts for the power supply.
    3. Place the power cable negative-wire terminal ring on the negative terminal for the power source and secure them with a terminal nut.
    4. Place the power cable positive-wire terminal ring on the positive terminal for the power source and secure them with a terminal nut.
    5. Place the power cable ground-wire terminal ring on the ground terminal for the power source and secure them with a terminal nut.
    6. If there is a safety cover for the power source terminals, place and secure it over the terminals to avoid an electrical shock hazard.
    7. Turn on the power at the power source circuit breaker.

**Step 3** For any DC power supply, do the following:

- a) Turn off the circuit breaker for the power source to avoid an electrical shock hazard.
- b) Verify that the power cable wires from the power source are connected to a connector block.
- c) Insert the connector block into the receptacle on the power supply. Make sure that the connector block clicks when fully inserted in the receptacle and does not pull out.
- d) If there is a safety cover for the terminals, place and secure it over the terminals to avoid an electrical shock hazard.
- e) Turn on the power at the circuit breaker for the DC power source.

**Step 4** Verify that the power supply LED is on and green.

**Step 5** Listen for the fans; they should begin operating when the power supply is powered.

**Step 6** After the switch boots, verify that the following LEDs are lit:

- On the fan modules, the Status (STA or STS) LED is green.

If a fan module Status LED is not green, try reinstalling the fan module.

- After initialization, the switch chassis Status (labeled as STA or STS) LED is green.

**Step 7**

Verify that the system software has booted and the switch has initialized without error messages.

A setup utility automatically launches the first time that you access the switch and guides you through the basic configuration. For instructions on how to configure the switch and check module connectivity, see the appropriate Cisco Nexus 9000 Series configuration guide.

---





## CHAPTER 4

# Connecting the Switch to the ACI Fabric

---

- [ACI Fabric Topology, on page 33](#)
- [Preparing to Connect to Other Devices, on page 34](#)
- [Connecting Leaf Switches to APICs, on page 35](#)
- [Connecting Leaf Switches to Spine Switches, on page 37](#)
- [FEX Conversion and Support, on page 38](#)
- [Installing a Gigabit Ethernet module \(GEM\), on page 40](#)
- [Migration of Nodes From a First Generation Switch to a Second Generation Switch, on page 40](#)
- [Setting Up an Optional Console Interface, on page 42](#)
- [Setting Up an Optional Management Connection, on page 43](#)
- [Maintaining Transceivers and Optical Cables, on page 43](#)

## ACI Fabric Topology

The ACI fabric topology includes the following major components:

- Application Centric Infrastructure Controller (APIC) appliance (cluster of APICs)
- Leaf switches (for switch compatibility, please see the [data sheets](#)).
- Spine switches (for switch compatibility, please see the [data sheets](#)).

For additional information, please see the [Cisco APIC Installation, Upgrade, and Downgrade Guide](#).



---

**Note** To prevent sub-optimal forwarding between endpoints, connect every leaf switch in the fabric to every spine switch in the same fabric.

---

As shown in the following figure, each APIC is connected to one or two leaf switches and each leaf switch should be connected to every spine switch in the same fabric.

Figure 1: Connections Between APIC Clusters, Leaf Nodes, and Spine Nodes

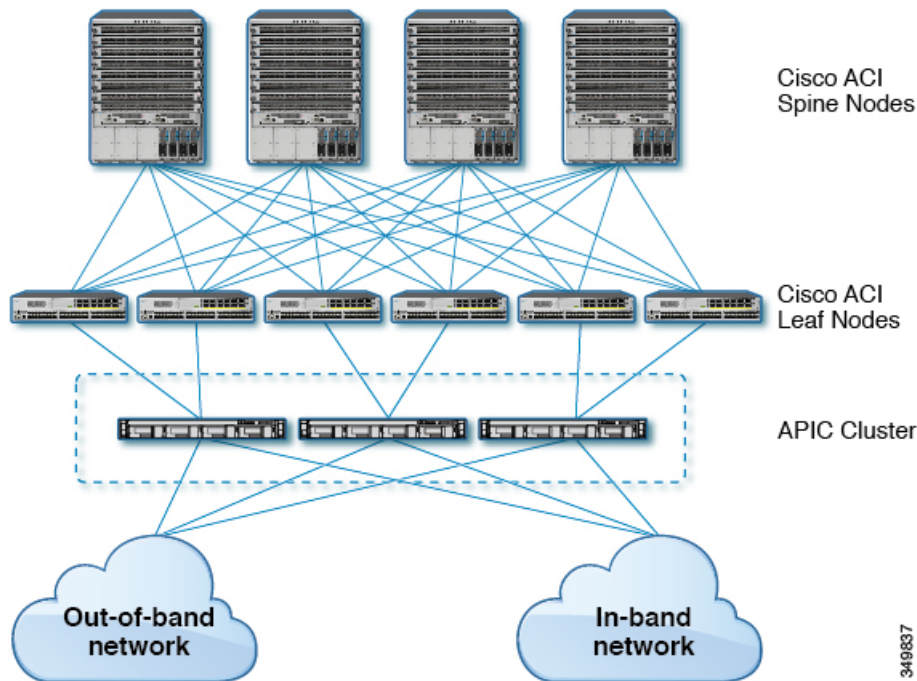

## Preparing to Connect to Other Devices

When preparing to connect the fabric devices, consider the following for each type of interface, and gather all of the required equipment before making the connections:

- Cabling type required for each interface type
- Distance limitations for each signal type
- Additional interface equipment required



**Note** When running power and data cables in overhead or subfloor cable trays, we strongly recommend that you locate power cables and other potential noise sources as far away as practical from network cabling that terminates on Cisco equipment. In situations where long parallel cable runs cannot be separated by at least 3.3 feet (1 meter), we recommend that you shield any potential noise sources by housing them in a grounded metallic conduit.

The optical transceivers that are not already assembled to their cables come separate from their cables. To prevent these transceivers and their cables from being damaged, we recommend that you keep the transceivers disconnected from their cables when installing them in ports and then insert the optical cable into the transceiver. When removing transceivers from ports, remove their cables before removing the transceivers.

To maximize the effectiveness and life of your transceivers and optical cables, do the following:

- Wear an ESD-preventative wrist strap that is connected to an earth ground whenever handling transceivers. The switch is typically grounded when you install transceivers and provides an ESD port to which you



can connect your wrist strap. If you cannot find an ESD port, connect the wrist strap to an earth ground (such as the grounding connection for the chassis).

- Do not remove or insert a transceiver more often than necessary. Repeated removals and insertions can shorten its useful life.
- Keep the transceivers and fiber-optic cables clean and dust free to maintain high signal accuracy and to prevent damage to the connectors. Attenuation (loss of light) increases with contamination and should be kept below 0.35 dB.
  - Clean these parts before installing them to prevent dust from scratching the fiber-optic cable ends.
  - Clean the connectors regularly; the required frequency of cleaning depends upon the environment. In addition, clean connectors if they are exposed to dust or accidentally touched. Both wet and dry cleaning techniques can be effective; refer to your site's fiber-optic connection cleaning procedures.
  - Do not touch the ends of connectors. Touching the ends can leave fingerprints and cause other contamination.
- Inspect routinely for dust and damage. If you suspect damage, clean and then inspect fiber ends under a microscope to determine if damage has occurred.

## Connecting Leaf Switches to APICs

You must downlink one or two (recommended for redundancy) Cisco Nexus 9300 platform ACI-mode leaf switches to each Application Policy Infrastructure Controller (APIC) in your ACI fabric. The type of virtual interface card (VIC) installed on the APIC determines the types of interface cables that you can use to connect the leaf switches to the APICs.

- The **VIC 1225T** module supports copper connectors, copper cables, and switches with copper downlink ports (such as: Cisco Nexus 93108TC-FX switch).
- The **VIC 1225** module supports optical transceivers, optical cables, and switches with optical downlink ports (such as: Cisco Nexus 93600CD-GX switch).
- The **VIC 1455** module supports optical transceivers, optical cables, and switches with optical downlink ports (such as: Cisco Nexus 93600CD-GX switch).



---

**Note** Breakout ports cannot be used for Cisco APIC connectivity.

---

### Before you begin

The APIC and leaf switches in the fabric must be fully installed in their racks and grounded.

### Step 1

Connect an interface cable to one of the two to four ports on the virtual interface card (VIC) installed on the APIC. If the cable is not already assembled to its transceivers, insert the transceiver into the VIC port and then connect the optical interface cable to the transceiver.

- For a **VIC 1225T** 10GBASE-T copper module, use 10GBASE-T cables with RJ-45 connectors.

- For a **VIC 1225** optical module, use one of the following sets of transceivers and cables:
  - Cisco 10GBASE-LR transceivers (SFP-10G-LR) supporting a link length of up to 6.1 miles (10 km)
  - Cisco 10GBASE-SR transceivers (SFP-10G-SR) supporting the following link lengths:
    - Using 2000 MHz MMF (OM3) for up to 984 feet (300 m)
    - Using 4700 MHz MMF (OM4) for up to 1312 feet (400 m)
  - Cisco SFP+ Active Optical Cables (SFP-10G-AOC $x$ M [where  $x=1, 3, 5, 7$  for lengths in meters])
  - Cisco SFP+ Twinax Cables (SFP-H10GB-CU $x$ M [where  $x=7$  for lengths in meters])
- For a **VIC 1455** SFP28 module, 10-Gigabit only, use one of the following sets of transceivers and cables:
  - Cisco 10GBASE-LR transceivers (SFP-10G-LR) supporting a link length of up to 6.1 miles (10 km)
  - Cisco 10GBASE-SR transceivers (SFP-10G-SR) supporting the following link lengths:
    - Using 2000 MHz MMF (OM3) for up to 984 feet (300 m)
    - Using 4700 MHz MMF (OM4) for up to 1312 feet (400 m)
  - Cisco SFP+ Active Optical Cables (SFP-10G-AOC $x$ M [where  $x=1, 2, 3, 5, 7, 10$  for lengths in meters])
  - Cisco SFP+ Twinax Cables (SFP-H10GB-CU $x$ M [where  $x=1, 2, 3, 5, 7, 10$  for lengths in meters])

**Note** The VIC 1455 has 4 ports, port-1, port-2, port-3, and port-4 from left to right.

- All ports must have the same speed, either 10-Gigabit or 25-Gigabit.
- Port-1 and port-2 is one pair, corresponding to eth2-1 on APIC and port-3 and port-4 is another pair, corresponding to eth2-2 on APIC. Only one connection is allowed for each pair. For example, you can connect one cable to either port-1 or port-2, and connect another cable to either port-3 or port-4 (**please do not connect two cables on any pair**).

To determine which transceivers, adapters, and cables support this switch, see the [Cisco Transceiver Modules Compatibility Information](#) document.

To see the transceiver specifications and installation information, see [Transceiver Module Installation Guides](#).

**Step 2** Connect the other end of the interface cable to a downlink port on a leaf switch.

- For a Cisco 10GBASE-LR or -SR transceiver and cable, insert the transceiver into a downlink optical port on a leaf switch before connecting the cable to the transceiver.
- For Cisco SFP+ Active Optical Cables, insert the transceiver on the cable into a downlink optical port on a leaf switch.
- For a 10GBASE-T copper cable, insert the RJ-45 connector on the cable into a downlink BASE-T port on a leaf switch.

**Note** To determine which transceivers, adapters, and cables support this switch, see the [Cisco Transceiver Modules Compatibility Information](#) document.

# Connecting Leaf Switches to Spine Switches

For optimal forwarding between endpoints, you must connect each leaf switch to every spine switch in the same ACI fabric.

To determine which transceivers, adapters, and cables support this switch, see the [Cisco Transceiver Modules Compatibility Information](#) document.

To see the transceiver specifications and installation information, see [Transceiver Module Installation Guides](#).



---

**Warning** **Statement 1055**—Class 1/1M Laser

Invisible laser radiation is present. Do not expose to users of telescopic optics. This applies to Class 1/1M laser products.



---

**Warning** **Statement 1056**—Unterminated Fiber Cable

Invisible laser radiation may be emitted from the end of the unterminated fiber cable or connector. Do not view directly with optical instruments. Viewing the laser output with certain optical instruments, for example, eye loupes, magnifiers, and microscopes, within a distance of 100 mm, may pose an eye hazard.

---

**Before you begin**

- The leaf and spine switches in the fabric (such as: N9k-C9364C, N9K-C9332C, N9K-C9316D-GX, and N9K-C9332D-GX2B) must be fully installed in their racks and grounded.
- If there are modular switches in the fabric, their ACI-mode line cards must already be installed. The line cards can be of the following types:
  - 32-port 100-Gigabit (such as: N9K-X9732C-EX)
  - 36-port 100-Gigabit (such as: N9K-X9736C-FX)
  - 16-port 400-Gigabit (such as: N9K-X9716D-GX)



---

**Note** You cannot include NX-OS line cards in the same chassis when running in ACI mode.

---



---

**Note** Multiple uplinks from a leaf switch to a spine switch is supported. A symmetrical topology is recommended so that all devices have equal access to resources.

---

- 
- Step 1** For the transceivers with removable cables, make sure that the transceivers are separated from their interface cables.
- Step 2** Insert the appropriate transceiver into an active uplink port on the leaf switch.
- Step 3** Insert the same type of transceiver in the spine switch port on the line card.
- Step 4** For transceivers with removable cables, insert the interface cable into the open end of each of those transceivers.
- Step 5** Repeat Steps 1 through 4 for each spine switch in the ACI fabric.  
The leaf switch is connected to each spine switch in the ACI fabric.
- Step 6** Repeat Steps 1 through 5 for each leaf switch in the ACI fabric.  
Each leaf switch in the ACI fabric is connected to each spine switch in the network,
- 

The fabric automatically implements Equal Cost Multi-Pathing (ECMP) and enables all links. You do not need to configure the links.

## FEX Conversion and Support

By default, Cisco Nexus switches operate in the switch mode. However, Cisco Nexus FX3 platform switches also support the Fabric Extender (FEX) mode.

This FEX mode allows a switch to operate like a Cisco Nexus 2000 series Fabric Extender. As a result, the switch will not require any:

- Independent software upgrades
- Configuration backups
- Other maintenance tasks

In addition to existing advantages of FEX topologies on ACI, FX3 switches in FEX mode support speeds up to 25G per Host Interface (HIF) connectivity to host.

The Nexus FX3 Switches supports FEX mode from ACI release, 6.0(2).

### Leaf to FEX Conversion

In Leaf to FEX conversion, FEX5 binary present in the leaf image will be used, so device will come up in FEX mode with the same version as before the conversion.

- To convert a leaf switch to a FEX mode switch:

- 
- Step 1** Login to the leaf, to be converted
- Step 2** Run `boot-fex` command on the ibash shell. In the backend FEX image will be verified and set as boot variable.
- Step 3** Run `reload` command. Then the leaf will be converted to FEX.
-

## FEX to Leaf Conversion

In FEX to leaf conversion, FEX can either use the existing leaf image which was used before converting to FEX or copy a new one after configuring management.

- To convert a FEX mode switch to a leaf switch:

---

**Step 1** Use an ACI image, which can be an existing leaf image in bootflash or copy a different ACI image to the FEX bootflash via `copy scp` command.

**Step 2** Run `boot aci <image>` CLI to set boot variable and convert to leaf.

---

## New FEX Setup

Cisco Nexus FX3 platform switches will be shipped with leaf mode.

- To use a Cisco Nexus FX3 platform switch as a FEX"

---

**Step 1** Run the `boot-fex` CLI via console to set the FEX boot variable and reload to convert to FEX.

**Step 2** Connect the new FEX to a Leaf in the topology.

---

## Change an Existing Leaf in the Topology to FEX

In an existing ACI topology, a Leaf switch will be connected to a Spine switch directly.

---

**Step 1** Leaf to FEX conversion can be triggered by running via `boot-fex` command

**Step 2** The FEX (previously leaf) will have to be re-connected to another Leaf in the topology for it to come up.

**Step 3** FEX policies can be configured on the APIC as required.

---

## Change an Existing FEX in the Topology to Leaf

In an existing ACI topology, a FEX switch will be connected to a Leaf switch directly.

---

**Step 1** FEX to Leaf conversion can be triggered using `boot aci <image>` command on FEX.

**Step 2** The Leaf (previously FEX) will have to be re-connected to a Spine switch in the topology for it to come up in APIC.

**Step 3** Leaf policies can then be configured on the APIC as required.

---

## Installing a Gigabit Ethernet module (GEM)

- 
- Step 1** Clear the switch's current configuration by using the `setup-clean-config` command.
- Step 2** Power off the switch by disconnecting the power.
- Step 3** Replace the current GEM card with the new GEM card.
- Step 4** Power on the switch.
- 

## Migration of Nodes From a First Generation Switch to a Second Generation Switch

You have first generation Cisco Nexus 9000 series switches that may or may not be comprising a virtual port channel (vPC). You are migrating to second generation Cisco Nexus 9000 series switches using the same cables.

First generation Cisco Nexus 9000 series switches include those switches that do not contain -EX, -FX, or -GX in the product ID.

Second generation Cisco Nexus 9000 series switches include those switches that have the -EX, -FX, -GX, or later suffix in the product ID.

To migrate the first generation switches to second generation switches, you must perform the steps in this procedure.

To determine which transceivers, adapters, and cables support this switch, see the [Cisco Transceiver Modules Compatibility Information](#) document.

To see the transceiver specifications and installation information, see [Transceiver Module Installation Guides](#).

### Before you begin

- Move any Cisco Application Policy Infrastructure Controllers (APICs) that are connected to the first generation switches that you are migrating to any other switches in the fabric and wait for the Cisco APIC cluster to become "Fully Fit."
- The following migration paths are supported:
  1. Migrating from first generation Cisco Application Centric Infrastructure (ACI) switches to second generation Cisco ACI switches that are running the same software release.
  2. Migrating from first generation Cisco ACI switches to second generation Cisco ACI switches that are running different software releases.

The second migration path is required where the existing switches are not supported on the new release that is required for the new switches. For example, if you want to migrate from the first generation Cisco ACI switches, such as Cisco Nexus 9300 (with the -E suffix or without any suffixes in the product ID) that are no longer supported starting on Cisco ACI switch 15.0(1) or later releases, to some of the new switches that are supported only from 15.0(1) or later.

When the first generation switches are comprising a vPC, complete the following mandatory prerequisite steps before you proceed with the second migration path:

- a. Due to potential traffic loss, it is recommended that that you perform the vPC migration during a maintenance window.
- b. Before you perform this procedure, the Auto Firmware Update policy must be disabled.
- c. Upgrade the Cisco APIC cluster to the 4.2(7v) release if the cluster is running an older release. Also upgrade the first generation switches to the 14.2(7v) release. Wait for the fabric to converge.
- d. Upgrade the Cisco APIC cluster to 5.2(7f) release and wait for the cluster to become "Fully Fit."
- e. Ensure that the new second generation switches are preloaded and running the equivalent release as the Cisco APICs, that is 15.2(7f) release. Other than source and target version software releases 4.2(7v)/14.2(7v) and 5.2(7f)/15.2(7f), no other software releases are supported for this migration procedure.



---

**Note**

- The number of ports and port types of the second generation switches must match the first generation switch that you are replacing. If the number does not match, then you must change the configuration to accommodate the new ports or port types. This is also applicable if you migrate the hardware while retaining the same software version.
- To migrate first generation non-vPC leaf switches or first generation spine switches to second generation switches, follow [Step 1, on page 41](#) through [Step 6, on page 41](#) in the procedure outlined below. vPC-related information is not applicable for this migration.

If you must migrate a first generation non-vPC leaf switch or a first generation spine switch to a second generation switch, the requirement of the source and target software release 4.2(7v)/14.2(7v) and 5.2(7f)/15.2(7f) is not required. Ensure that the Cisco ACI fabric is running the required software release that supports the second generation switch PID.

---

**Step 1** From the Cisco APIC GUI, perform the **Remove From Controller** operation for the operational secondary vPC switch node.

The Cisco APIC clean reboots the switch. Wait for about 10 minutes for this operation to finish. This action prompts all traffic to use the other first generation switch for data traffic.

**Note** There will be a loss of traffic for a few seconds for the operational secondary vPC when you perform the **Remove From Controller** operation.

**Step 2** Disconnect the cabling from the first generation switch that you just removed.

**Step 3** Uninstall the first generation switch by reversing the order of the steps in the "Installing the Switch Chassis" section of the switch-specific *Hardware Installation Guide*.

**Step 4** Install the second generation switch by following the steps in the "Installing the Switch Chassis" section of the switch-specific *Hardware Installation Guide*.

**Step 5** Connect the loose cabling that you removed from the first generation switch to the same ports on the second generation switch.

**Step 6** Register the new second generation switch with the Cisco APIC.

Register the new node with the same node name and node ID. This switch becomes part of the fabric. The Cisco APIC pushes the policies to the new switch and keeps down the vPC legs because there is a mismatch of the generation of switches. At this point, the vPC primary continues to send the data traffic.

**Step 7** Before you proceed to [Step 8, on page 42](#), wait for 10 to 15 minutes for the new switch to download the configurations.

**Step 8** From the Cisco APIC GUI, perform the **Remove From Controller** operation for the vPC primary. The Cisco APIC clean reboots the switch.

Wait for about 10 minutes for this operation to finish. The vPC leg on the second generation switch, which the Cisco APIC kept down earlier, comes up. This action prompts all traffic to move to the new second generation switch. The vPC ports on the new second generation switch can take a few minutes to come up, during which time there will be traffic drops. The duration of traffic drops varies by the scale and flows in the fabric.

**Step 9** Disconnect the cabling from the first generation switch.

**Step 10** Uninstall the first generation switch as you did in [Step 3, on page 41](#).

**Step 11** Install the second generation switch as you did in [Step 4, on page 41](#).

**Step 12** Connect the loose cabling as you did in [Step 5, on page 41](#).

**Step 13** Register the new second generation switch with the Cisco APIC.

Register the new node with the same node name and node ID. This switch becomes part of the fabric. The Cisco APIC pushes policies to the new switch and the vPC legs comes up and starts passing traffic.

## Setting Up an Optional Console Interface

You can optionally set up a console interface for performing the initial configuration of the switch. To do this, use the interface cable provided in the accessory kit to connect the switch to your console device. You can connect the console port on the switch to a modem. If you do not connect it to a modem, make the connection either before powering up the switch or after completing the boot process for the switch.

### Before you begin

The console device must support VT100 terminal emulations and asynchronous transmissions.

**Step 1** Configure the terminal emulator program to match each of the following default port characteristics:

- 9600 baud
- 8 data bits
- 1 stop bit
- No parity

**Step 2** Insert the RJ-45 connector on the interface cable found in the accessory kit into the RS-232 port on the switch and insert the DB-9 connector on the other end of the cable to the serial port on the console device.



**What to do next**

You can now perform the initial configuration for the switch (see the *Cisco ACI Getting Started Guide*).

## Setting Up an Optional Management Connection

You can optionally set up an out-of-band management connection for monitoring and troubleshooting purposes. To do this, depending on your switch, you connect either the RJ-45 management port or the SFP management port on the switch to an external hub, switch, or router.

**Before you begin**

To prevent an IP address conflict, you must complete the initial configuration for the switch and establish an IP address before you create the management connection.

- 
- Step 1** Connect the interface cable to a management port on the switch.
- Step 2** Connect the other end of the cable to an external hub, switch, or router.
- 

## Maintaining Transceivers and Optical Cables

Transceivers and fiber-optic cables must be kept clean and dust free to maintain high signal accuracy and prevent damage to the connectors. Contamination increases attenuation (loss of light) and should be below 0.35 dB.

Consider the following maintenance guidelines:

- Transceivers are static sensitive. To prevent ESD damage, wear an ESD-preventative wrist strap that is connected to the grounded chassis.
- Do not remove and insert a transceiver more often than is necessary. Repeated removals and insertions can shorten its useful life.
- Keep all optical connections covered when not in use. Clean them before using to prevent dust from scratching the fiber-optic cable ends.
- Do not touch the ends of connectors. Touching the ends can leave fingerprints and cause other contamination.
- Clean the connectors regularly; the required frequency of cleaning depends upon the environment. In addition, clean connectors if they are exposed to dust or accidentally touched. Both wet and dry cleaning techniques can be effective; refer to the fiber-optic connection cleaning procedures for your site.
- Inspect routinely for dust and damage. If you suspect damage, clean and then inspect fiber ends under a microscope to determine if damage has occurred.





## CHAPTER 5

# Replacing Components

---

- [Replacing a Fan Module, on page 45](#)
- [Replacing a Power Supply Module, on page 46](#)

## Replacing a Fan Module

You can replace a fan module while the switch is operating so long as you perform the replacement within one minute. If you cannot perform the replacement within one minute, leave the original fan module in the chassis to maintain the designed airflow until you have the replacement fan module on hand and can perform the replacement.



---

**Caution** If you are replacing a module during operations, be sure that the replacement fan module has the correct direction of airflow, which means that it has the same airflow direction as the other modules in the chassis. Also, be sure that the airflow direction takes in air from a cold aisle and exhausts to a hot aisle. Otherwise, the switch can overheat and shutdown.

If you are changing the airflow direction of all the modules in the chassis, you must shutdown the switch before replacing all the fan and power supply modules with modules using the other airflow direction. During operations, all of the modules must have the same direction of airflow.

---

## Removing a Fan Module



---

**Caution** The fans might still be turning when you remove the fan assembly from the chassis. Keep fingers, screwdrivers, and other objects away from the openings in the fan assembly's housing.

---

**Step 1** On the fan module that you are removing, press the two sides of the fan module handle together, and pull on the handles enough to unseat it from its connectors.

**Step 2** Holding the handle, pull the module out of the chassis.

**Caution** Do not touch the electrical connectors on the back side of the module and prevent anything else from coming into contact with and damaging the connectors.

---

## Installing a Fan Module

### Before you begin

- A fan slot must be open and ready for the new fan module to be installed.
  - You must have a new fan module on hand and ready to install within one minute of removing the original fan module if the switch is operating.
  - The new fan module must have the same airflow direction as the other fan and power supply modules installed in the switch.
- 

- Step 1** Holding the fan module by its handle, align the back of the fan module (the side with the electrical connectors) to the open fan slot in the chassis.
- Step 2** Slide the fan module into the slot until it clicks in place.
- Step 3** Verify that the Status (STS) LED turns on and becomes green.
- 

## Replacing a Power Supply Module

The switch requires two power supplies for redundancy. With one power supply providing the necessary power for operations, you can replace the other power supply during operations so long as the new power supply has the same airflow direction as the other modules in the chassis.

You can replace a power supply with another supported power supply that has the same power source type as the other installed power supply. Additionally, the airflow direction of the power supply must match or conform to the airflow direction of the installed fan modules. For the airflow direction used by the switch, see the coloring of the fan modules.

## Replacing an AC Power Supply

You can replace an AC power supply during operations so long as the other power supply provides to the switch.

### Before you begin



**Note** You can determine the airflow direction by looking at the coloring of the latch on each power supply. AC power supplies with burgundy latches have port-side intake airflow direction, and power supplies with blue latches have port-side exhaust airflow direction.

---

- 
- An AC power source must be within reach of the power cable that will be used with the replacement power supply. If you are using  $n+n$  power redundancy, there must be a separate power source for each power supply installed in the chassis.
- There must be an earth ground connection to the chassis that you are installing the replacement module. AC power supplies connected to AC power sources are automatically grounded through their power cable.

---

**Step 1**

Remove an AC power supply as follows:

- a) Holding the plug for the power cable, pull the plug out from the power receptacle on the power supply and verify that both power supply LEDs are off.
- b) Grasp the power supply handle while pressing the colored release latch towards the power supply handle.
- c) Place your other hand under the power supply to support it while you slide it out of the chassis.

**Caution** Do not touch the electrical connections on the back side of the module and prevent anything else from coming into contact with and damaging the connectors.

**Step 2**

Install the replacement power supply as follows:

- a) Holding the replacement power supply with one hand underneath the module and the other hand holding the handle, turn the power supply so that its release latch is on the right side and align the back end of the power supply (the end with the electrical connections) to the open power supply slot before carefully sliding the power supply all the way into the slot until it clicks into place.

**Note** If the power supply does not fit into the open slot, turn the module over before sliding it carefully into the open slot.

- b) Test the installation by trying to pull the power supply out of the slot without using the release latch.

If the power supply does not move out of place, it is secured in the slot. If the power supply moves, carefully press it all the way into the slot until it clicks in place.

- c) Attach the power cable to the electrical outlet on the front of the power supply.
- d) Make sure that the other end of the power cable is attached to the appropriate power source for the power supply.

**Note** Depending on the outlet receptacle on your power distribution unit, you might need the optional jumper cable to connect the switch to your outlet receptacle.

- e) Verify that the power supply is operational by making sure that the power supply LED is green.
-





## APPENDIX **A**

# Rack Specifications

---

- [Overview of Racks, on page 49](#)
- [General Requirements for Cabinets and Racks, on page 49](#)
- [Requirements Specific to Standard Open Racks, on page 50](#)
- [Requirements Specific to Perforated Cabinets, on page 50](#)
- [Cable Management Guidelines, on page 50](#)

## Overview of Racks

You can install the switch in the following types of cabinets and racks, assuming an external ambient air temperature range of 0 to 104°F (0 to 40°C):

- Standard perforated cabinets
- Solid-walled cabinets with a roof fan tray (bottom to top cooling)
- Standard open racks



---

**Note** If you are selecting an enclosed cabinet, we recommend one of the thermally validated types, either standard perforated or solid-walled with a fan tray.

---



---

**Note** We do not recommend that you use racks that have obstructions (such as power strips), because the obstructions could impair access to field-replaceable units (FRUs).

---

## General Requirements for Cabinets and Racks

The cabinet or rack must also meet the following requirements:

- Standard 19-inch (48.3 cm) (two- or four-post EIA cabinet or rack, with mounting rails that conform to English universal hole spacing per section 1 of ANSI/EIA-310-D-1992). For more information, see [Requirements Specific to Perforated Cabinets, on page 50](#).

- The minimum vertical rack space requirement per chassis is:
  - For a one RU (rack unit) switch, 1.75 inches (4.4 cm)
  - For a one and a half RU (rack unit) switch, 2.63 (6.68 cm)
  - For a two RU (rack unit) switch, 3.5 inches (8.8 cm)
  - For a three RU (rack unit) switch, 5.25 inches (13.3 cm)
- The width between the rack-mounting rails must be at least 17.75 inches (45.0 cm) if the rear of the device is not attached to the rack. For four-post EIA racks, this measurement is the distance between the two front rails.

Four-post EIA cabinets (perforated or solid-walled) must meet the following requirements:

- The minimum spacing for the bend radius for fiber-optic cables should have the front-mounting rails of the cabinet offset from the front door by a minimum of 3 inches (7.6 cm).
- The distance between the outside face of the front mounting rail and the outside face of the back mounting rail should be 23.0 to 30.0 inches (58.4 to 76.2 cm) to allow for rear-bracket installation.

## Requirements Specific to Standard Open Racks

If you are mounting the chassis in an open rack (no side panels or doors), ensure that the rack meets the following requirements:

- The minimum vertical rack space per chassis must be equal to the rack unit (RU) of the chassis. One rack unit is equal to 1.75 inches (4.4 cm).
- The distance between the chassis air vents and any walls should be 2.5 inches (6.4 cm).

## Requirements Specific to Perforated Cabinets

A perforated cabinet has perforations in its front and rear doors and side walls. Perforated cabinets must meet the following requirements:

- The front and rear doors must have at least a 60 percent open area perforation pattern, with at least 15 square inches (96.8 square cm) of open area per rack unit of door height.
- The roof should be perforated with at least a 20 percent open area.
- The cabinet floor should be open or perforated to enhance cooling.

The Cisco R Series rack conforms to these requirements.

## Cable Management Guidelines

To help with cable management, you might want to allow additional space in the rack above and below the chassis to make it easier to route all of the fiber optic or copper cables through the rack.





## APPENDIX **B**

# System Specifications

- [Environmental Specifications, on page 51](#)
- [Switch Dimensions, on page 51](#)
- [Switch and Module Weights and Quantities, on page 52](#)
- [Transceiver and Cable Specifications, on page 52](#)
- [Switch Power Input Requirements, on page 52](#)
- [Power Specifications, on page 53](#)
- [Power Cable Specifications, on page 55](#)
- [Regulatory Standards Compliance Specifications, on page 57](#)

## Environmental Specifications

Environment		Specification
Temperature	Ambient operating temperature	32 to 104°F (0 to 40°C)
	Ambient nonoperating	−40 to 158°F (−40 to 70°C)
Relative humidity	Nonoperating	5 to 95%
	Operating	5 to 90%
Altitude	Operating	0 to 13,123 feet (0 to 4,000 meters)

## Switch Dimensions

Switch	Width	Depth	Height
Cisco Nexus 93180YC-FX3	17.3 inches (43.9 cm)	19.5 inches (49.6 cm)	1.72 inches (4.4 cm) (1 RU)

## Switch and Module Weights and Quantities

Component	Weight per Unit	Quantity
Cisco Nexus 93180YC-FX3 Chassis (N9K-C93180YC-FX3)	21 lb (9.52 kg)	1
Fan Module	—	4
– Port-side exhaust (blue) (NXA-FAN-35CFM-PE)	0.26 lb (0.12 kg)	
– Port-side intake (burgundy) (NXA-FAN-35CFM-PI)		
Power Supply module	—	2 (1 for operations and 1 for redundancy)
– 650-W AC port-side exhaust (blue) (NXA-PAC-650W-PE)	2.42 lb (1.1 kg)	
– 650-W AC port-side intake (burgundy) (NXA-PAC-650W-PI)	2.42 lb (1.1 kg)	
– 1200-W HVAC/HVDC dual-direction (white) (N9K-PUV-1200W)		
– 930-W DC port-side exhaust (blue) (NXA-PDC-930W-PE)		
– 930-W DC port-side intake (burgundy) (NXA-PDC-930W-PI)		

## Transceiver and Cable Specifications

To see the transceiver specifications and installation information, see <https://www.cisco.com/c/en/us/support/interfaces-modules/transceiver-modules/products-device-support-tables-list.html>.

## Switch Power Input Requirements

The following table lists the typical amount of power that the switch consumes. It also lists the maximum amount of power that you must provision for the switch and power supply for peak conditions.



**Note** Some power supplies have capabilities that are greater than the maximum power requirements for a switch. To determine the power consumption characteristics for the switch, use the typical and maximum requirements that are listed in the following table.

Switch	Typical Power Consumption (AC or DC)	Maximum Power Consumption (AC or DC)	Heat Dissipation Requirement
Cisco Nexus 93180YC-FX3	375	600 W	2047.285 BTUs per hour

# Power Specifications

Power specifications include the specifications for each type of power supply module.

## 650-W AC Power Supply Specifications

These specifications apply to the following power supplies:

- NXA-PAC-650W-PE
- NXA-PAC-650W-PI

Characteristic	Specification
AC input voltage	Nominal range: 100 and 240 VAC (Range: 90-132 VAC, 180-264 VAC)
AC input frequency	Nominal range: 50 to 60 Hz (Range: 47-63 Hz)
Maximum AC input current	7.6 A at 90 - 132 VAC 3.65 A at 180 - 264 VAC
Maximum input volt-amperes	760 VA at 100 VAC
Maximum output power per power supply	650 W
Maximum inrush current	11 A (sub-cycle duration)
Maximum hold-up time	12 ms at 650 W
Power supply output voltage	12 VDC
Power supply standby voltage	12 VDC
Efficiency rating	Climate Savers Platinum Efficiency (80Plus Platinum certified)
Form factor	RSP1

## 1200-W HVAC/HVDC Power Supply Specifications

These specifications apply to the 1200-W HVAC/HVDC (N9K-PUV-1200W) power supplies.

Characteristic	Specification
Input voltage <ul style="list-style-type: none"> <li>• AC (for 1230 W output)</li> <li>• DC (for 1230 W output)</li> </ul>	Nominal (Range) <ul style="list-style-type: none"> <li>• 200 to 277 VAC</li> </ul>
AC input frequency	Nominal: 50 to 60 Hz (Range: 47-63 Hz)

Characteristic	Specification
Maximum AC input current	100 VAC, 10A
Maximum inrush current	35 A (cold turn on); 70 A (hot turn on)
Maximum output Watts <ul style="list-style-type: none"> <li>• For 200 to 277 VAC</li> <li>• For 192 to 400 VDC</li> </ul>	Per power supply <ul style="list-style-type: none"> <li>• 1230 W</li> <li>• 1230 W</li> </ul>
Power supply output voltage <ul style="list-style-type: none"> <li>• For 200 to 277 VAC</li> <li>• For 192 to 400 VDC</li> </ul>	Per power supply <ul style="list-style-type: none"> <li>• 12 VDC at 100 A</li> <li>• 12 VDC at 100 A</li> </ul>
Power supply standby voltage	12 V at 2.5 A
Efficiency rating	Climate Savers Platinum Efficiency (80Plus Platinum certified)
Form factor	RSP1

## 930-W DC Power Supply Specifications

These specifications apply to the following power supplies:

- NXA-PDC-930W-PE
- NXA-PDC-930W-PI

Characteristic	Specification
DC input voltage range	Nominal range: -48 to -60 VDC nominal (Range: -40 to -60 VDC)
Maximum DC input current	23 A at -48 VDC
Maximum output power per power supply	930 W
Maximum inrush current	35 A (sub-cycle duration)
Maximum hold-up time	8 ms at 930 W
Power supply output voltage	12 VDC
Power supply standby voltage	12 VDC
Efficiency rating	Greater than 92% at 50% load
Form factor	RSP1

# Power Cable Specifications



The following sections specify the power cables that you can order and use with this switch.

## Power Cable Specifications for AC Power Supplies

Locale	Power Cord Part Number	Cord Set Description
	CAB-C13-C14-2M	Power Cord Jumper, C13-C14 Connectors, 6.6 feet (2.0 m)
	CAB-C13-CBN	Cabinet jumper power cord, 250 VAC, 10 A, C14-C13 connectors, 2.3 feet (0.7 m)
Argentina	CAB-250V-10A-AR	250 V, 10 A, 8.2 feet (2.5 m)
Australia	CAB-9K10A-AU	250 VAC, 10 A, 3112 plug, 8.2 feet (2.5 m)
Brazil	CAB-250V-10A-BR	250 V, 10 A, 6.9 feet (2.1 m)
European Union	CAB-9K10A-EU	250 VAC, 10 A, CEE 7/7 plug, 8.2 feet (2.5 m)
India	CAB-IND-10A	10 A, 8.2 feet (2.5 m)
India	CAB-C13-C14-2M-IN	Power Cord Jumper, C13-C14 Connectors, 6.6 feet (2.0 m)
India	CAB-C13-C14-3M-IN	Power Cord Jumper, C13-C14 Connectors, 9.8 feet (3.0 m)
Israel	CAB-250V-10A-IS	250 V, 10 A, 8.2 feet (2.5 m)
Italy	CAB-9K10A-IT	250 VAC, 10 A, CEI 23-16/VII plug, 8.2 feet (2.5 m)
Japan	CAB-C13-C14-2M-JP	Power Cord Jumper, C13-C14 Connectors, 6.6 feet (2.0 m)
North America	CAB-9K12A-NA	125 VAC, 13 A, NEMA 5-15 plug, 8.2 feet (2.5 m)
North America	CAB-AC-L620-C13	NEMA L6-20-C13, 6.6 feet (2.0 m)
North America	CAB-N5K6A-NA	200/240V, 6A, 8.2 feet (2.5 m)
Peoples Republic of China	CAB-250V-10A-CN	250 V, 10 A, 8.2 feet (2.5 m)
South Africa	CAB-250V-10A-ID	250 V, 10 A, 8.2 feet (2.5 m)
Switzerland	CAB-9K10A-SW	250 VAC, 10 A, MP232 plug, 8.2 feet (2.5 m)
United Kingdom	CAB-9K10A-UK	250 VAC, 10 A, BS1363 plug (13 A fuse), 8.2 (2.5 m)

Locale	Power Cord Part Number	Cord Set Description
All except Argentina, Brazil, and Japan	NO-POWER-CORD	No power cord included with switch

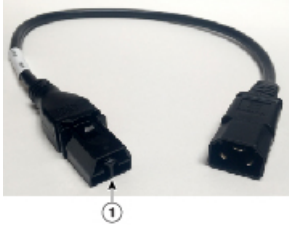
## HVAC/HVDC Power Cables Supported by ACI-Mode and NX-OS Mode Switches

Part Number	Cord Set Description	Photo
CAB-HVAC-SD-0.6M	HVAC 2-foot (0.6 m) cable with Saf-D-Grid and SD connectors 277V AC	
CAB-HVAC-C14-2M	HVAC 6.6-foot (2.0 m) cable with Saf-D-Grid and C14 (use for up to 240 V) connector 250V AC	
CAB-HVAC-RT-0.6M	HVAC 2-foot (0.6 m) cable with Saf-D-Grid and RT connector 277V AC	
CAB-HVDC-3T-2M	HVDC 6.6-foot (2.0 m) cable with Saf-D-Grid and three terminal connectors 300V AC / 400V DC (+200/-200 V DC)	
NO-POWER-CORD	All except Argentina, Brazil, and Japan No power cord included with switch	Not applicable

**Table 4: HVAC/HVDC Power Cables Callout Table**

1	Connect this end to the power supply unit.
---	--

## DC Power Cable Specifications

Part ID Number	Description	Photo
NXA-PDC-930W-PE/PI	The 930W DC power supply (NXA-PDC-930W-PE/PI) is shipped with cable CAB-48DC-40A-8AWG.	

## Regulatory Standards Compliance Specifications

The following table lists the regulatory standards compliance for the switch.

**Table 5: Regulatory Standards Compliance: Safety and EMC**

Specification	Description
Regulatory compliance	Products should comply with CE Markings according to directives 2004/108/EC and 2006/95/EC.
Safety	<ul style="list-style-type: none"> <li>• CAN/CSA-C22.2 No. 60950-1 Second Edition</li> <li>• CAN/CSA-C22.2 No. 62368-1-19 Third Edition</li> <li>• NRTL 60950-1 Second Edition</li> <li>• IEC 62368-1</li> <li>• EN 62368-1</li> <li>• AS/NZS 62368-1</li> <li>• GB4943</li> <li>• UL 62368-1</li> </ul>

Specification	Description
EMC: Emissions	<ul style="list-style-type: none"><li>• 47CFR Part 15 (CFR 47) Class A</li><li>• AS/NZS CISPR22 Class A</li><li>• CISPR22 Class A</li><li>• EN55022 Class A</li><li>• ICES003 Class A</li><li>• VCCI Class A</li><li>• EN61000-3-2</li><li>• EN61000-3-3</li><li>• KN22 Class A</li><li>• CNS13438 Class A</li></ul>
EMC: Immunity	<ul style="list-style-type: none"><li>• EN55024</li><li>• CISPR24</li><li>• EN300386</li><li>• KN 61000-4 series</li></ul>
RoHS	The product is RoH-6 compliant with exceptions for leaded-ball grid-array (BGA) balls and lead press-fit connectors.





## APPENDIX C

### LEDs

- [Switch Chassis LEDs, on page 59](#)
- [Fan Module LEDs, on page 60](#)
- [Power Supply LEDs, on page 60](#)

### Switch Chassis LEDs

The BCN, STS, and ENV, LEDs are located on the left side of the front of the switch. The port LEDs appear as triangles pointing up or down to the nearest port.

LED	Color	Status
BCN	Flashing blue	The operator has activated this LED to identify this switch in the chassis.
	Off	This switch is not being identified.
STS	Green	The switch is operational.
	Flashing amber	The switch is booting up.
	Amber	Temperature exceeds the minor alarm threshold.
	Red	Temperature exceeds the major alarm threshold.
	Off	The switch is not receiving power.
ENV	Green	Fans and power supply modules are operational.
	Amber	At least one fan or power supply module is not operating.
(port)	Green	Port admin state is 'Enabled', SFP is present and the interface is connected (that is, cabled, and the link is up).
	Amber	Port admin state is 'Disabled, or the SFP is absent, or both.
	Off	Port admin state is 'Enabled' and SFP is present, but interface is not connected.

LED	Color	Status
(SYNC)	Green	The frequency are synchronized to external interface. The external interface could be GPS, Recovered RX clk).
	Amber	Freerun/Holdover - Time core is in freerun or holdover mode.
	Off	Time core clock synchronization is disabled.
(TIMING)	Green	The time, phase are synchronized to external interface. The external interface could be (GPS, FP).
	Amber	Freerun/Holdover - Time core is in freerun or holdover mode.
	Off	Time core clock synchronization is disabled.
(GNSS)	Green	GPS interface provisioned and ports are turned on. ToD, 1PPS, 10MHz are all valid.
	Off	Either the interface is not provisioned, or the ports are not turned on. ToD, 1PPS, 10MHz are not valid.

## Fan Module LEDs

The fan module LED is located below the air holes on the front of the module.

LED	Color	Status
STS	Green	The fan module is operational.
	Red	The fan module is not operational (fan is probably not functional).
	Off	Fan module is not receiving power.

## Power Supply LEDs

The power supply LEDs are located on the left right portion of the power supply. Combinations of states indicated by the Okay and Fault LEDs indicate the status for the module as shown in the following table.

OK LED	FAIL or FAIL/ID LED	Status
Green	Off	Power supply is on and outputting power to the switch.
Flashing green	Off	Power supply is connected to an AC power source but not outputting power to the switch. The power supply may not be properly installed in the chassis.
Off	Off	Either all the installed power supplies are not receiving power or an uninstalled power supply is not receiving power.

OK LED	FAIL or FAIL/ID LED	Status
Off	Flashing amber	Power supply is operating but a warning condition has occurred—possibly one of the following conditions: <ul style="list-style-type: none"> <li>• High temperature</li> <li>• High power</li> <li>• Slow power supply fan</li> <li>• Low voltage</li> <li>• Power supply is installed in the chassis but was disconnected from the power source.</li> </ul>
Off	Flashing amber (10 seconds) then amber	Power supply is installed without a connection to a power source.
Off	Amber	Power supply failure—possibly one of the following conditions: <ul style="list-style-type: none"> <li>• Over voltage</li> <li>• Over current</li> <li>• Over temperature</li> <li>• Power supply fan failure</li> </ul>





# APPENDIX D

## Additional Kits

- [Rack Mount Kit NXK-ACC-KIT-1RU](#), on page 63
- [Airflow Sleeve](#), on page 64

### Rack Mount Kit NXK-ACC-KIT-1RU

The following table lists and illustrates the contents for the 1-RU rack-mount kit (NXK-ACC-KIT-1RU).

Illustration	Description	Quantity
	Rack-mount kit <ul style="list-style-type: none"> <li>• Front brackets (2)</li> <li>• Rear brackets (2)</li> <li>• Slider rails (2)</li> <li>• M4 Phillips pan-head screws (10)</li> </ul>	1
	Ground lug kit <ul style="list-style-type: none"> <li>• Two-hole lug (1)</li> <li>• M4 x 8-mm Phillips pan-head screws (2)</li> </ul>	1
Not applicable	EAC Compliance document	1
Not applicable	Hazardous substances list for customers in China	1

The following table lists and illustrates the console cable (CAB-CONSOLE-RJ45) that can be ordered.

Illustration	Description	Quantity
	Console cable with DB-9F and RJ-45F connectors	1

# Airflow Sleeve

The following table lists and illustrates the airflow sleeve (N9K-AIRFLOW-SLV).

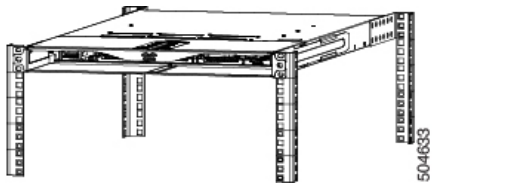
Illustration	Description	Quantity
 <p>504633</p>	Airflow sleeve	1