



## PA-4T+ Synchronous Serial Port Adapter Installation and Configuration

Product Number: PA-4T+=

Platforms Supported: Catalyst 5000 Family Switches with RSM/VIP2, Catalyst 6000 Family Switches with Catalyst 6000 Family FlexWAN Module, Cisco 7100 Series Routers, Cisco 7200 Series Routers, Cisco 7200 VXR Routers, Cisco uBR7200 Series Routers, Cisco 7201 Router, Cisco 7301 Router, Cisco 7304 PCI Port Adapter Carrier Card in the Cisco 7304 Router, Cisco 7401ASR Router, and VIP in the Cisco 7000 Series and Cisco 7500 Series Routers

Americas Headquarters  
Cisco Systems, Inc.  
170 West Tasman Drive  
San Jose, CA 95134-1706  
USA  
<http://www.cisco.com>  
Tel: 408 526-4000  
800 553-NETS (6387)  
Fax: 408 527-0883

Text Part Number: OL-3561-04

THE SPECIFICATIONS AND INFORMATION REGARDING THE PRODUCTS IN THIS MANUAL ARE SUBJECT TO CHANGE WITHOUT NOTICE. ALL STATEMENTS, INFORMATION, AND RECOMMENDATIONS IN THIS MANUAL ARE BELIEVED TO BE ACCURATE BUT ARE PRESENTED WITHOUT WARRANTY OF ANY KIND, EXPRESS OR IMPLIED. USERS MUST TAKE FULL RESPONSIBILITY FOR THEIR APPLICATION OF ANY PRODUCTS.

THE SOFTWARE LICENSE AND LIMITED WARRANTY FOR THE ACCOMPANYING PRODUCT ARE SET FORTH IN THE INFORMATION PACKET THAT SHIPPED WITH THE PRODUCT AND ARE INCORPORATED HEREIN BY THIS REFERENCE. IF YOU ARE UNABLE TO LOCATE THE SOFTWARE LICENSE OR LIMITED WARRANTY, CONTACT YOUR CISCO REPRESENTATIVE FOR A COPY.

The following information is for FCC compliance of Class A devices: This equipment has been tested and found to comply with the limits for a Class A digital device, pursuant to part 15 of the FCC rules. These limits are designed to provide reasonable protection against harmful interference when the equipment is operated in a commercial environment. This equipment generates, uses, and can radiate radio-frequency energy and, if not installed and used in accordance with the instruction manual, may cause harmful interference to radio communications. Operation of this equipment in a residential area is likely to cause harmful interference, in which case users will be required to correct the interference at their own expense.

The following information is for FCC compliance of Class B devices: The equipment described in this manual generates and may radiate radio-frequency energy. If it is not installed in accordance with Cisco's installation instructions, it may cause interference with radio and television reception. This equipment has been tested and found to comply with the limits for a Class B digital device in accordance with the specifications in part 15 of the FCC rules. These specifications are designed to provide reasonable protection against such interference in a residential installation. However, there is no guarantee that interference will not occur in a particular installation.

Modifying the equipment without Cisco's written authorization may result in the equipment no longer complying with FCC requirements for Class A or Class B digital devices. In that event, your right to use the equipment may be limited by FCC regulations, and you may be required to correct any interference to radio or television communications at your own expense.

You can determine whether your equipment is causing interference by turning it off. If the interference stops, it was probably caused by the Cisco equipment or one of its peripheral devices. If the equipment causes interference to radio or television reception, try to correct the interference by using one or more of the following measures:

- Turn the television or radio antenna until the interference stops.
- Move the equipment to one side or the other of the television or radio.
- Move the equipment farther away from the television or radio.
- Plug the equipment into an outlet that is on a different circuit from the television or radio. (That is, make certain the equipment and the television or radio are on circuits controlled by different circuit breakers or fuses.)

Modifications to this product not authorized by Cisco Systems, Inc. could void the FCC approval and negate your authority to operate the product.

The Cisco implementation of TCP header compression is an adaptation of a program developed by the University of California, Berkeley (UCB) as part of UCB's public domain version of the UNIX operating system. All rights reserved. Copyright © 1981, Regents of the University of California.

NOTWITHSTANDING ANY OTHER WARRANTY HEREIN, ALL DOCUMENT FILES AND SOFTWARE OF THESE SUPPLIERS ARE PROVIDED "AS IS" WITH ALL FAULTS. CISCO AND THE ABOVE-NAMED SUPPLIERS DISCLAIM ALL WARRANTIES, EXPRESSED OR IMPLIED, INCLUDING, WITHOUT LIMITATION, THOSE OF MERCHANTABILITY, FITNESS FOR A PARTICULAR PURPOSE AND NONINFRINGEMENT OR ARISING FROM A COURSE OF DEALING, USAGE, OR TRADE PRACTICE.

IN NO EVENT SHALL CISCO OR ITS SUPPLIERS BE LIABLE FOR ANY INDIRECT, SPECIAL, CONSEQUENTIAL, OR INCIDENTAL DAMAGES, INCLUDING, WITHOUT LIMITATION, LOST PROFITS OR LOSS OR DAMAGE TO DATA ARISING OUT OF THE USE OR INABILITY TO USE THIS MANUAL, EVEN IF CISCO OR ITS SUPPLIERS HAVE BEEN ADVISED OF THE POSSIBILITY OF SUCH DAMAGES.



# CONTENTS

<b>Preface</b>	<b>vii</b>
Document Revision History	vii
Objectives	vii
Organization	viii
Related Documentation	viii
Obtaining Documentation, Obtaining Support, and Security Guidelines	xii

---

## CHAPTER 1

<b>Overview</b>	<b>1-1</b>
Port Adapter Overview	1-1
Synchronous Serial Overview	1-2
Serial Interface Specifications	1-3
LEDs	1-4
Cables, Connectors, and Pinouts	1-5
PA-4T+ Receptacles and Cables	1-5
EIA/TIA-232 Connections	1-7
EIA/TIA-449 Connections	1-8
V.35 Connections	1-8
X.21 Connections	1-9
EIA-530 Connections	1-9
PA-4T+ Port Adapter Cable Pinouts	1-9
Port Adapter Slot Locations on the Supported Platforms	1-15
Catalyst RSM/VIP2 Slot Numbering	1-16
Catalyst 6000 Family FlexWAN Module Slot Numbering	1-16
Cisco 7100 Series Routers Slot Numbering	1-17
Cisco 7200 Series Routers and Cisco 7200 VXR Routers Slot Numbering	1-18
Cisco uBR7200 Series Router Slot Numbering	1-20
Cisco 7201 Router Slot Numbering	1-21
Cisco 7301 Router Slot Numbering	1-21
Cisco 7304 PCI Port Adapter Carrier Card Slot Numbering	1-22
Cisco 7401ASR Router Slot Numbering	1-23
Cisco 7000 Series Routers and Cisco7500 Series Routers VIP Slot Numbering	1-23
Identifying Interface Addresses	1-25

Catalyst RSM/VIP2 Interface Addresses	1-26
Catalyst 6000 Family FlexWAN Module	1-27
Cisco 7100 Series Routers Interface Addresses	1-27
Cisco 7200 Series Routers and Cisco 7200 VXR Routers Interface Addresses	1-27
Cisco uBR7200 Series Routers Interface Addresses	1-28
Cisco 7201 Router Interface Addresses	1-28
Cisco 7301 Router Interface Addresses	1-28
Cisco 7304 PCI Port Adapter Carrier Card Interface Addresses	1-28
Cisco 7401ASR Router Interface Addresses	1-28
Cisco 7000 Series Routers and Cisco 7500 Series Routers VIP Interface Addresses	1-29

CHAPTER 2

**Preparing for Installation** 2-1

Required Tools and Equipment	2-1
Software and Hardware Requirements	2-2
Checking Hardware and Software Compatibility	2-3
Safety Guidelines	2-3
Safety Warnings	2-3
Electrical Equipment Guidelines	2-8
Telephone Wiring Guidelines	2-9
Preventing Electrostatic Discharge Damage	2-9
FCC Class A Compliance	2-10

CHAPTER 3

**Removing and Installing Port Adapters** 3-1

Handling Port Adapters	3-1
Online Insertion and Removal	3-2
Warnings and Cautions	3-3
Port Adapter Removal and Installation	3-4
Catalyst RSM/VIP2—Removing and Installing a Port Adapter	3-5
Catalyst 6000 Family FlexWAN Module—Removing and Installing a Port Adapter	3-6
Cisco 7100 Series Routers—Removing and Installing a Port Adapter	3-7
Cisco 7200 Series Routers and Cisco 7200 VXR Routers—Removing and Installing a Port Adapter	3-8
Cisco uBR7200 Series Routers—Removing a Port Adapter	3-9
Cisco uBR7200 Series Routers—Installing a Port Adapter	3-10
Cisco 7201 Router—Removing and Installing a Port Adapter	3-11
Cisco 7301 Router—Removing and Installing a Port Adapter	3-12
Cisco 7304 PCI Port Adapter Carrier Card—Removing and Installing a Port Adapter	3-13
Cisco 7401ASR Router—Removing and Installing a Port Adapter	3-15
VIP—Removing and Installing a Port Adapter	3-16

## CHAPTER 4

**Attaching the PA-4T+ Interface Cables** 4-1

Connecting PA-4T+ Port Adapter Interface Cables 4-1

Determining the Port Mode 4-2

## CHAPTER 5

**Configuring the PA-4T+ Interfaces** 5-1

Using the EXEC Command Interpreter 5-1

Configuring the Interfaces 5-2

Shutting Down an Interface 5-2

Performing a Basic Configuration 5-8

Configuring Timing (Clock) Signals 5-11

Setting the Clock Rate 5-12

Inverting the Clock Signal 5-13

Inverting the Data Signal 5-14

Configuring NRZI Format 5-14

Configuring Cyclic Redundancy Checks 5-15

Configuring Half-Duplex and Binary Synchronous Communications in Cisco 7200 Series Routers 5-16

Checking the Configuration 5-18

Using show Commands to Verify the New Interface Status 5-18

Using the show version or show hardware Commands 5-20

Using the show diag Command 5-25

Using the show interfaces Command 5-28

Using the ping Command to Verify Network Connectivity 5-33

Using loopback Commands 5-34





## Preface

---

This preface describes the objectives and organization of this document and explains how to find additional information on related products and services. This preface contains the following sections:

- [Document Revision History, page vii](#)
- [Objectives, page vii](#)
- [Organization, page viii](#)
- [Related Documentation, page viii](#)
- [Obtaining Documentation, Obtaining Support, and Security Guidelines, page xii](#)

## Document Revision History

The Document Revision History table below, beginning with version OL-3561-04, records technical changes to this document.

Document Version	Date	Change Summary
OL-3561-04	April, 2007	Adds Cisco 7201 router information.

## Objectives

This document describes how to install and configure the PA-4T+ port adapter, which is used in the following platforms:

- Catalyst 5000 family switches with the Route Switch Module (RSM)/second-generation Versatile Interface Processor (VIP2)
- Catalyst 6000 family switches with the Catalyst 6000 family FlexWAN module
- Cisco 7000 series routers with VIP, including the Cisco 7000 and Cisco 7010, and 7000 Series Route Switch Processor (RSP7000) and 7000 Series Chassis Interface (RSP7000CI)
- Cisco 7100 series routers, consisting of the Cisco 7120 series and Cisco 7140 series
- Cisco 7200 series routers and Cisco 7200 VXR routers, consisting of the two-slot Cisco 7202, four-slot Cisco 7204 and Cisco 7204VXR, and the six-slot Cisco 7206 and Cisco 7206VXR
- Cisco uBR7200 series universal broadband routers, consisting of the three-slot Cisco uBR7223 and the six-slot Cisco uBR7246

- Cisco 7201 router
- Cisco 7301 router
- Cisco 7304 PCI Port Adapter Carrier Card in the Cisco 7304 router
- Cisco 7401ASR router
- Cisco 7500 series routers with VIP, including the Cisco 7505, Cisco 7507, Cisco 7505-MX, Cisco 7513, Cisco 7513-MX, and Cisco 7576

## Organization

This document contains the following chapters:

Section	Title	Description
Chapter 1	<a href="#">Overview</a>	Describes the PA-4T+ and its LED displays, cables, and receptacles.
Chapter 2	<a href="#">Preparing for Installation</a>	Describes safety considerations, tools required, and procedures you should perform before the actual installation.
Chapter 3	<a href="#">Removing and Installing Port Adapters</a>	Describes the procedures for installing and removing PA-4T+ port adapters in the supported platforms.
Chapter 4	<a href="#">Attaching the PA-4T+ Interface Cables</a>	Provides instructions for connecting port adapter cables on the supported platforms.
Chapter 5	<a href="#">Configuring the PA-4T+ Interfaces</a>	Provides instructions for configuring the PA-4T+ on the supported platforms.

## Related Documentation

Your router or switch and the Cisco IOS software running on it contain extensive features and functionality, which are documented in the following resources:

- Cisco IOS software:

For configuration information and support, refer to the modular configuration and modular command reference publications in the Cisco IOS software configuration documentation set that corresponds to the software release installed on your Cisco hardware.



**Note** You can access Cisco IOS software configuration and hardware installation and maintenance documentation on the World Wide Web at <http://www.cisco.com>, <http://www-china.cisco.com>, or <http://www-europe.cisco.com>.



- Catalyst 5000 family switches with RSM/VIP2:
  - For an online directory to quickly access documents for Cisco Catalyst 5000 series switches, refer to the *Cisco Catalyst 5000 Series Switches Install and Upgrade Guides* index at the following URL:  
[http://www.cisco.com/en/US/products/hw/switches/ps679/prod\\_installation\\_guides\\_list.html](http://www.cisco.com/en/US/products/hw/switches/ps679/prod_installation_guides_list.html)
  - For hardware installation and maintenance information, refer to the following documents:
    - *Route Switch Module Catalyst VIP2-15 and VIP2-40 Installation and Configuration Note*
    - *Catalyst 5000 Series Route Switch Module Installation and Configuration Note*
    - The installation and configuration guide and quick start for your Cisco Catalyst 5000 series switch
- Catalyst 6000 family switches with FlexWAN module:
  - For an online directory to quickly access documents for Cisco Catalyst 6000 family switches, refer to the *Cisco Catalyst 6500 Series Switches Documentation Roadmaps* index at the following URL:  
[http://www.cisco.com/en/US/products/hw/switches/ps708/products\\_documentation\\_roadmaps\\_list.html](http://www.cisco.com/en/US/products/hw/switches/ps708/products_documentation_roadmaps_list.html)
  - For hardware installation and maintenance information, refer to the following documents:
    - *Catalyst 6000 Family FlexWAN Module Installation and Configuration Note*
    - The hardware and software documents for your Catalyst 6000 family switch
- Cisco 7000 series routers:
  - For an online directory to quickly access documents for Cisco 7000 series routers, refer to the *Cisco 7000 Series Routers Introduction* index at the following URL:  
[http://www.cisco.com/en/US/products/hw/routers/ps332/tsd\\_products\\_support\\_eol\\_series\\_home.html](http://www.cisco.com/en/US/products/hw/routers/ps332/tsd_products_support_eol_series_home.html)
  - For hardware installation and maintenance information, refer to the following documents:
    - *Cisco 7000 Hardware Installation and Maintenance* for your router.
    - *Second-Generation Versatile Interface Processor (VIP2) Installation and Configuration*
    - *Fourth-Generation Versatile Interface Processor (VIP4) Installation and Configuration*
    - *Versatile Interface Processor (VIP6-80) Installation and Configuration Guide*
- Cisco 7100 series routers:
  - For an online directory to quickly access documents for Cisco 7100 series routers, refer to the *Cisco 7100 Series Documentation* roadmap at the following URL:  
[http://www.cisco.com/en/US/products/hw/vpndevc/ps333/products\\_product\\_index09186a00800fa142.html](http://www.cisco.com/en/US/products/hw/vpndevc/ps333/products_product_index09186a00800fa142.html)
  - For hardware installation and configuration information refer to the *Cisco 7100 Series VPN Router Installation and Configuration Guide*.
  - For information on setting up a Virtual Private Network, refer to the *Cisco 7100 Series VPN Configuration Guide*.

- Cisco 7200 series routers:
  - For an online directory to quickly access documents for Cisco 7200 series routers, refer to the *Cisco 7200 Series Routers Documentation Roadmap* at the following URL:  
[http://www.cisco.com/en/US/products/hw/routers/ps341/products\\_documentation\\_roadmap09186a00801c0915.html](http://www.cisco.com/en/US/products/hw/routers/ps341/products_documentation_roadmap09186a00801c0915.html)
  - For hardware installation and configuration information (including the Cisco 7206 or Cisco 7206VXR as a router shelf in a Cisco AS5800 Universal Access Server), refer to the online installation and configuration guide and quick start for your Cisco 7200 series router.
  - For port adapter hardware and memory configuration guidelines, refer to the *Cisco 7200 Series Port Adapter Hardware Configuration Guidelines*.
  - For information on network processing engines or network services engines, refer to the *Network Processing Engine and Network Services Engine Installation and Configuration* document.
- Cisco 7200 VXR routers:
  - For an online directory to quickly access documents for Cisco 7200 VXR routers, refer to the *Cisco 7200 Series Routers Documentation Roadmap* at the following URL:  
[http://www.cisco.com/en/US/products/hw/routers/ps341/products\\_documentation\\_roadmap09186a00801c0915.html](http://www.cisco.com/en/US/products/hw/routers/ps341/products_documentation_roadmap09186a00801c0915.html)
  - For hardware installation and maintenance information, refer to the *Cisco 7200 VXR Installation and Configuration Guide* or the *Cisco 7200 VXR Routers Quick Start Guide*.
- Cisco uBR7200 series routers:
  - For an online directory to quickly access documents for Cisco uBR7200 Universal Broadband routers, refer to the *Cisco uBR7200 Universal Broadband Router Documentation Roadmap* at the following URL:  
[http://www.cisco.com/en/US/products/hw/cable/ps2217/products\\_documentation\\_roadmap09186a00805e0d0c.html](http://www.cisco.com/en/US/products/hw/cable/ps2217/products_documentation_roadmap09186a00805e0d0c.html)
- Cisco 7201 router:
  - For an online directory to quickly access documents for the Cisco 7201 router, refer to the *Cisco 7201 Router Documentation Roadmap* at the following URL:  
[http://www.cisco.com/en/US/customer/products/hw/routers/ps341/products\\_documentation\\_roadmap09186a00807f635a.html](http://www.cisco.com/en/US/customer/products/hw/routers/ps341/products_documentation_roadmap09186a00807f635a.html)
  - For hardware installation and maintenance information, refer to the *Cisco 7201 Installation and Configuration Guide* or the *Cisco 7201 Router Quick Start Guide*.
- Cisco 7301 router:
  - For an online directory to quickly access documents for the Cisco 7301 router, refer to the *Cisco 7301 Internet Router Documentation Roadmap* at the following URL:  
[http://www.cisco.com/en/US/products/hw/routers/ps352/products\\_documentation\\_roadmap09186a00801c0f21.html](http://www.cisco.com/en/US/products/hw/routers/ps352/products_documentation_roadmap09186a00801c0f21.html)
  - For hardware installation and maintenance information, refer to the *Cisco 7301 Installation and Configuration Guide* or the *Cisco 7301 Router Quick Start Guide*.

- Cisco 7304 PCI port adapter carrier card in Cisco 7304 router:
  - For an online directory to quickly access documents for the Cisco 7304 PCI Port Adapter Carrier Card in the Cisco 7301 router, refer to the *Cisco 7304 Router Line Card, Carrier Card, Port Adapter, Modular Services Card, and Shared Port Adapter Documentation Roadmap* at the following URL:  
[http://www.cisco.com/en/US/products/hw/routers/ps352/products\\_documentation\\_roadmap09186a00801c0f5e.html](http://www.cisco.com/en/US/products/hw/routers/ps352/products_documentation_roadmap09186a00801c0f5e.html)
  - For hardware installation and maintenance information, refer to the *Cisco 7304 PCI Port Adapter Carrier Card Installation and Configuration Guide*.
- Cisco 7401ASR router:
  - For an online directory to quickly access documents for the Cisco 7401ASR router, refer to the *Cisco 7401ASR Router Documentation Roadmap* at the following URL:  
[http://www.cisco.com/en/US/products/hw/routers/ps354/products\\_documentation\\_roadmap09186a00801c0fd5.html](http://www.cisco.com/en/US/products/hw/routers/ps354/products_documentation_roadmap09186a00801c0fd5.html)
  - For hardware installation and maintenance information, refer to the *Cisco 7401ASR Installation and Configuration Guide* or the *Cisco 7401ASR Router Quick Start Guide*.
- Cisco 7500 series routers:
  - For an online directory to quickly access documents for the Cisco 7500 series routers, refer to the *Cisco 7500 Series Routers Documentation Roadmap* at the following URL:  
[http://www.cisco.com/en/US/products/hw/routers/ps359/products\\_documentation\\_roadmap09186a00801c0f9b.html](http://www.cisco.com/en/US/products/hw/routers/ps359/products_documentation_roadmap09186a00801c0f9b.html)
  - For hardware installation and maintenance information, refer to the following documents:
    - *Cisco 7500 Series Installation and Configuration Guide* or the quick start for your Cisco 7500 series router.
    - *Second-Generation Versatile Interface Processor (VIP2) Installation and Configuration*
    - *Fourth-Generation Versatile Interface Processor (VIP4) Installation and Configuration*
    - *Versatile Interface Processor (VIP6-80) Installation and Configuration Guide*
- For international agency compliance, safety, and statutory information for WAN interfaces, refer to the following documents. Use the documentation roadmap for your particular router to link to the appropriate documents for your router:
  - *Regulatory Compliance and Safety Information for the Catalyst 5000 Family Switches*
  - *Regulatory Compliance and Safety Information for the Catalyst 6000 Family Switches*
  - *Regulatory Compliance and Safety Information for the Cisco 7000 Series Routers*
  - *Regulatory Compliance and Safety Information for Cisco 7100 Series VPN Routers*
  - *Regulatory Compliance and Safety Information for the Cisco 7200 Series Routers*
  - *Regulatory Compliance and Safety Information for the Cisco uBR7200 Series Universal Broadband Routers*
  - *Regulatory Compliance and Safety Information for the Cisco 7301 Internet Router*
  - *Regulatory Compliance and Safety Information for the Cisco 7304 Internet Router*
  - *Regulatory Compliance and Safety Information for the Cisco 7401ASR Internet Router*
  - *Regulatory Compliance and Safety Information for the Cisco 7500 Series Routers*

# Obtaining Documentation, Obtaining Support, and Security Guidelines

For information on obtaining documentation, obtaining support, providing documentation feedback, security guidelines, and also recommended aliases and general Cisco documents, see the monthly What's New in Cisco Product Documentation, which also lists all new and revised technical documentation at:

<http://www.cisco.com/en/US/docs/general/whatsnew/whatsnew.html>



# CHAPTER 1

## Overview

This chapter describes the PA-4T+ port adapter and contains the following sections:

- [Port Adapter Overview, page 1-1](#)
- [Synchronous Serial Overview, page 1-2](#)
- [Serial Interface Specifications, page 1-3](#)
- [LEDs, page 1-4](#)
- [Cables, Connectors, and Pinouts, page 1-5](#)
- [Port Adapter Slot Locations on the Supported Platforms, page 1-15](#)
- [Identifying Interface Addresses, page 1-25](#)

## Port Adapter Overview

The PA-4T+ provides the following electrical interfaces:

- EIA/TIA-232
- EIA/TIA-449
- EIA-530. X.21
- V.35

Each interface complies with its specific interface specifications. The cable attached to each PA-4T+ port adapter's interface ports determines its type (EIA/TIA-232 and so forth) and its mode (data communications equipment [DCE] or data terminal equipment [DTE]).



Note

The PA-4T+, shown in [Figure 1-1](#), provides enhanced performance over the PA-4T, shown in [Figure 1-2](#). To determine if a PA-4T+ or PA-4T is installed in your router, view the port adapters' faceplate labels or use the **show diag** command to view installed interface types.

Figure 1-1 PA-4T+ —Faceplate View

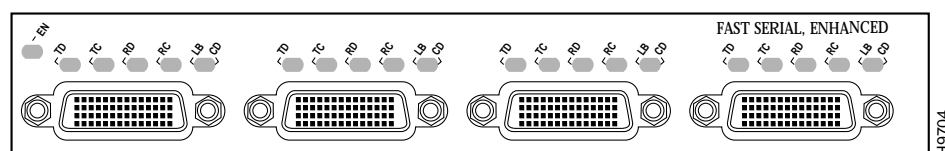

H9704

Figure 1-2 PA-4T Port Adapter—Faceplate View

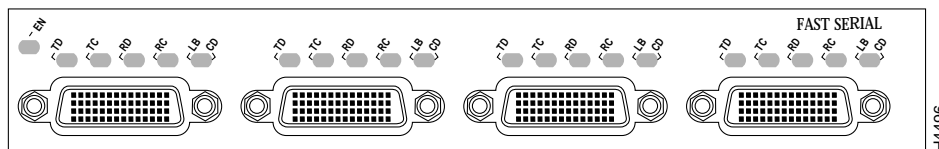

The PA-4T+ provides four synchronous serial ports, and each port supports full-duplex operations at T1 and E1 speeds.

Speed is controlled by three variables:

- The number of ports in use
- The maximum speed allowed by the port adapter
- The maximum speed of the attached CSU/DSU.

The CSU/DSU determines the maximum speed of the full-duplex port. No configuration is necessary. If a CSU/DSU runs at a maximum speed of 1.55 Mbps (T1 speed), using only one port in the port adapter will not make this CSU/DSU run at E2 speed. On the other hand, if a CSU/DSU is capable of E2 speed (8 Mbps), this CSU/DSU will take the maximum bandwidth of the port adapter. To ensure this speed, no other port can be used. If you use another port, the speed of the CSU/DSU capable of E2 speed is reduced, because the port adapter shares the bandwidth between the two ports.



Note

---

For running at speeds above 2 Mbps, the PA-H with appropriate DSU is a better choice.

---

When two full-duplex ports are in use, the maximum speed for each is 4 Mbps. When four full-duplex ports are in use, the maximum speed for each is 1.55 Mbps (T1) or 2.048 Mbps (E1).

## Synchronous Serial Overview

The PA-4T+ provides four channel-independent, synchronous serial ports that support full-duplex operation at T1 (1.544-Mbps) and E1 (2.048-Mbps) speeds. Each port supports any of the available interface types:

- EIA/TIA-232
- EIA/TIA-449
- V.35, X.21
- EIA-530

EIA/TIA-232, which is the most common interface standard in the U.S., supports unbalanced circuits at signal speeds up to 64 kbps. EIA/TIA-449, which supports balanced (EIA/TIA-422) and unbalanced (EIA/TIA-423) transmissions, is a faster (up to 2 Mbps) version of EIA/TIA-232 that provides more functions and supports transmissions over greater distances. The EIA/TIA-449 standard was intended to replace EIA/TIA-232, but it was not widely adopted.



Note

---

The EIA/TIA standards were referred to as recommended standards called RS-232 and RS-449 prior to their acceptance by the ANSI committee.

---

The resistance to convert to EIA/TIA-449 was due primarily to the large installed base of DB-25 hardware and to the larger size of the 37-pin EIA/TIA-449 connectors, which limited the number of connections possible (fewer than is possible with the smaller, 25-pin EIA/TIA-232 connector).

EIA-530, which supports balanced transmission, provides the increased functionality, speed, and distance of EIA/TIA-449 on the smaller, DB-25 connector used for EIA/TIA-232. The EIA-530 standard was created to support the more sophisticated circuitry of EIA/TIA-449 on the large number of existing EIA/TIA-232 (DB-25) hardware instead of the larger, 37-pin connectors used for EIA/TIA-449. EIA-530 refers to the electrical specifications of EIA/TIA-422 and EIA/TIA-423. The specification recommends a maximum speed of 2 Mbps. EIA-530 is used primarily in the United States.

The V.35 interface is most commonly used in the United States and throughout Europe, and is recommended for speeds up to 48 kbps. The X.21 interface uses a 15-pin connection for balanced circuits and is commonly used in the United Kingdom to connect public data networks. X.21 relocates some of the logic functions to the data terminal equipment (DTE) and data communications equipment (DCE) interfaces and, as a result, requires fewer circuits and a smaller connector than EIA/TIA-232.

All interface types except EIA-530 can be individually configured for operation with either external (DTE mode) or internal (DCE mode) timing signals; EIA-530 operates with external timing only. In addition, all VIP serial interface types support nonreturn to zero (NRZ) and nonreturn to zero inverted (NRZI) format, and both 16-bit and 32-bit cyclic redundancy checks (CRCs). The default configuration is for NRZ format and 16-bit CRC. You can change the default settings with software commands. (For more information, see [Chapter 5, “Configuring the PA-4T+ Interfaces.”](#))

There is no default mode or clock rate set on the VIP serial ports, although an internal clock signal is present on all ports for DCE support. The internal clock also allows you to perform local loopback tests without having to terminate the port or connect a cable. (All interface types except X.21 DTE support loopback.) To use the port as a DCE interface, you must set the clock rate and connect a DCE adapter cable. To use the port as a DTE interface, you need only connect a DTE adapter cable to the port. Because the serial adapter cables determine the mode and interface type, the PA-4T+ interface becomes a DTE when a DTE cable is connected to it.

If a DTE cable is connected to a port with a clock rate set, the DTE ignores the clock rate and uses the external clock signal that is sent from the remote DCE. For a brief description of the **clockrate** command, see [Chapter 5, “Configuring the PA-4T+ Interfaces.”](#) For complete command descriptions and instructions, see the publications listed in the section “[Related Documentation](#)” section on page viii.

## Serial Interface Specifications

The PA-4T+ provides up to four synchronous serial interfaces. Each interface allows a maximum bandwidth of 2.048 Mbps; the speed depends on the type of electrical interface used. Use EIA/TIA-232 for speeds of 64 kilobits per second (kbps) and below, and use X.21, EIA/TIA-449, V.35, or EIA-530 for higher speeds.

Serial signals can travel a limited distance at any given bit rate; generally, the slower the baud rate, the greater the distance. All serial signals are subject to distance limits beyond which a signal degrades significantly or is completely lost.

[Table 1-1](#) lists the recommended (standard) maximum speeds and distances for each PA-4T+ serial interface type. The recommended maximum rate for V.35 is 2.048 Mbps.

**Table 1-1 Standards for Transmission Speed Versus Distance**

Rate (bps)	EIA/TIA-232 Distances		EIA/TIA-449, X.21, V.35, EIA-530 Distances	
	Feet	Meters	Feet	Meters
2400	200	60	4,100	1,250
4800	100	30	2,050	625
9600	50	15	1,025	312
19200	25	7.6	513	156
38400	12	3.7	256	78
56000	8.6	2.6	102	31
1544000 (T1)	–	–	50	15

Balanced drivers allow EIA/TIA-449 signals to travel greater distances than EIA/TIA-232. The recommended distance limits for EIA/TIA-449 shown in Table 1-1 are also valid for V.35, X.21, and EIA-530. EIA/TIA-449 and EIA-530 support 2.048-Mbps rates, and V.35 supports 2.048-Mbps rates without any problems; we do not recommend exceeding published specifications for transmission speed versus distance. Do so at your own risk.

## LEDs

The PA-4T+ contains the ENABLED LED, standard on all port adapters, and one status LED for each port. After system initialization, the ENABLED LED goes on to indicate that the PA-4T+ has been enabled for operation. (The LEDs are shown in [Figure 1-3](#).)

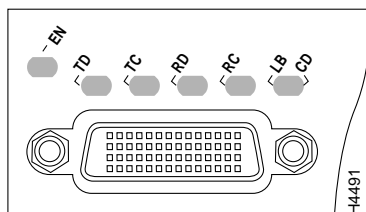
**Figure 1-3 PA-4T+ LEDs**

The following conditions must be met before the PA-4T+ is enabled:

- The port adapter is correctly connected to the backplane midplane and receiving power.
- A valid system software image for the port adapter has been downloaded successfully.
- The system software recognizes the port adapter or VIP with an installed PA-4T+.

If any of the above conditions are not met, or if the initialization fails for other reasons, the ENABLED LED will not go on.



Table 1-2 lists port LED status indications.

**Table 1-2 PA-4T+ Port LEDs**

LED Label	Color	State	Function
EN	Green	On	Indicates ports are ready.
TD	Green	On	DTE—Transmit data out. DCE—Transmit data in.
TC	Green	On	DTE—Transmit clock in. DCE—Transmit clock in (TXCE).
RD	Green	On	DTE—Receive data in. DCE—Receive data out.
RC	Green	On	DTE—Receive clock in. DCE—Receive clock out.
LB/CD	Green	On	Indicates DTR, DSR, RTS, CTS, or DCD is active.
	Green	Flashing	Indicates RTS, CTS, or DCD is sending and receiving data in half-duplex mode.
	Yellow	On	Indicates local loop or internal loop active.

## Cables, Connectors, and Pinouts

The following sections describe the serial receptacles on the PA-4T+ and the cables and pinouts for the various serial interface cables.

### PA-4T+ Receptacles and Cables

The PA-4T+ and adapter cables allow a high density of interface ports, regardless of the size of the connectors typically used with each electrical interface type. All ports use an identical 60-pin D-shell receptacle that supports all interface types. Each port requires a serial adapter cable, which provides the interface between the high-density serial port and the standard connectors that are commonly used for each electrical interface type.



#### Note

The adapter cable determines the electrical interface type and mode of the port (DTE or DCE) to which it is connected.

The network end of the cable is an industry-standard connector for the type of electrical interface that the cable supports. For most interface types, the adapter cable for DTE mode uses a plug at the network end, and the cable for DCE mode uses a receptacle at the network end. Exceptions are V.35 adapter cables, which are available with either a V.35 plug or a receptacle for either mode, and the EIA-530 adapter cable, which is available only in DTE mode with a DB-25 plug at the network end. The mode is labeled on the molded plastic connector shell at the ends of all cables except V.35 (which uses the standard Winchester block-type connector instead of a molded plastic D shell).

Following are the available interface cable options (and product numbers) for the mode and network-end connectors for each cable:

- EIA/TIA-232: DTE mode with a DB-25 plug (CAB-232MT); DCE mode with a DB-25 receptacle (CAB-232FC).
- EIA/TIA-449: DTE mode with a 37-pin D-shell plug (CAB-449MT); DCE mode with a 37-pin D-shell receptacle (CAB-449C).
- V.35: DTE mode or DCE mode with a 34-pin Winchester-type V.35 plug (CAB-V35MT or CAB-V35MC); DTE mode or DCE mode with a 34-pin Winchester-type V.35 receptacle (CAB-V35FT or CAB-V35FC). Also available is a cable with a male DB-60 plug on the router end and a male DB-34 shielded plug on the network end (CAB-V35MTS).
- X.21: DTE mode with a DB-15 plug (CAB-X21MT); DCE mode with a DB-25 receptacle (CAB-X21FC).
- EIA-530: DTE mode with a DB-25 plug (CAB-530MT).



**Note**

For cable pinouts, see the “PA-4T+ Port Adapter Cable Pinouts” section on page 1-9.

Figure 1-4 shows the serial port adapter cables for connection from the PA-4T+ port adapters to your network.

**Figure 1-4** Serial Port Adapter Cables

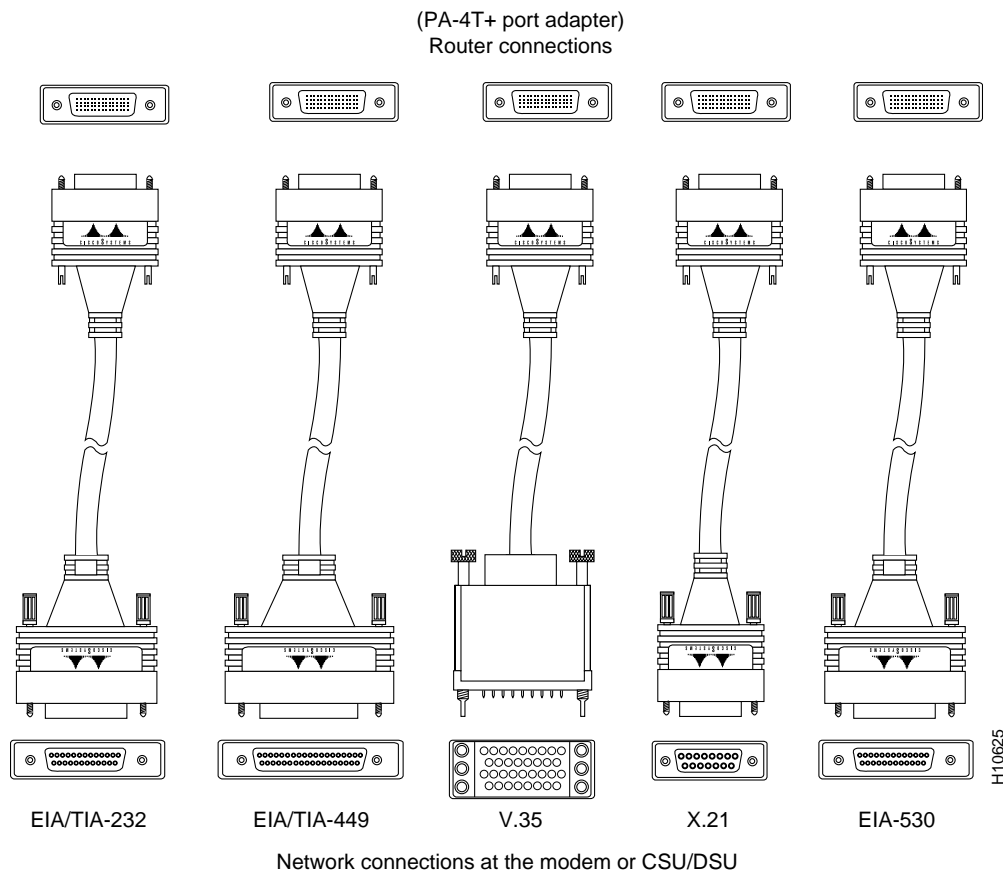

Metric (M3) thumbscrews are included with each port adapter cable to allow connections to devices that use metric hardware. Because the PA-4T+ uses a special, high-density port that requires special adapter cables for each electrical interface type, we recommend that you obtain serial interface cables from the factory.

## EIA/TIA-232 Connections

The router end of all EIA/TIA-232 adapter cables is a high-density 60-pin plug. The network end of the adapter cable is a standard 25-pin D-shell connector (known as a DB-25) that is commonly used for EIA/TIA-232 connections. [Figure 1-5](#) shows the connectors at the network end of the adapter cable.



**Note**

The system console and auxiliary ports on the Route Switch Processor (RSP) in the Cisco 7500 series also use EIA/TIA-232 connections; however, the PA-4T+ interfaces support synchronous serial connections, and the console and auxiliary ports only support asynchronous connections. Use caution when connecting EIA/TIA-232 cables to the PA-4T+ receptacles.



**Note**

Do not use the Cisco Systems-provided EIA/TIA-232 adapter cable CAB-232MT= to connect a PA-4T+ interface that is configured for DTE mode *directly* to an NEC - NEXTSTAR 1E model C4969 MD/SAC unit interface that is configured for DCE mode. This action will keep transmit and receive data signals from being properly exchanged between the two interfaces.

Instead, you must connect an additional, intermediate adapter cable—with standard EIA/TIA-232 DB-25 connectors at both ends—from the network end of CAB-232MT to the standard EIA/TIA-232 DB-25 connector (the DCE interface) on the NEC - NEXTSTAR 1E model C4969 MD/SAC unit. Cisco Systems does not provide this additional cable; however, the cable's signals and pin assignments are listed in [Table 1-4](#).



**Note**

You can use the Cisco Systems-provided EIA/TIA-232 adapter cable CAB-232FC to connect a PA-4T+ interface that is configured for DCE mode *directly* to an NEC - NEXTSTAR 1E model C4969 MD/SAC unit interface that is configured for DTE mode.

**Figure 1-5** EIA/TIA-232 Adapter Cable Connectors

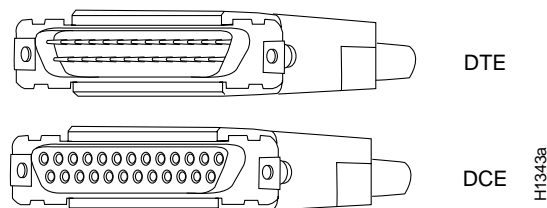

## EIA/TIA-449 Connections

The router end of all EIA/TIA-449 adapter cables is a high-density, 60-pin plug. The network end of the adapter cable provides a standard 37-pin D-shell connector, which is commonly used for EIA/TIA-449 connections. [Figure 1-6](#) shows the connectors at the network end of the adapter cable. EIA/TIA-449 cables are available as either DTE (DB-37 plug) or DCE (DB-37 receptacle).

**Figure 1-6** EIA/TIA-449 Adapter Cable Connectors

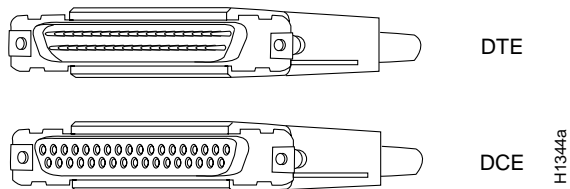

## V.35 Connections

The router end of all V.35 adapter cables is a high-density, 60-pin plug. The network end of the adapter cable provides a standard 34-pin Winchester-type connector commonly used for V.35 connections. [Figure 1-7](#) shows the connectors at the network end of the V.35 adapter cable. V.35 cables are available with a standard V.35 plug for DTE mode (CAB-V35MT) or a V.35 receptacle for DCE mode (CAB-V35FC).

**Figure 1-7** V.35 Adapter Cable Connectors

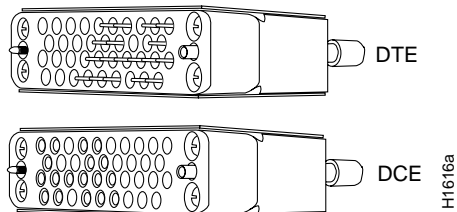

**Note**

Also available, but not shown in [Figure 1-7](#), are CAB-V35MC, a V.35 cable with a plug on the network end for DCE mode, and CAB-V35FT, a V.35 cable with a receptacle on the network end for DTE mode. These cables are used for connecting V.35-equipped systems back to back.

## X.21 Connections

The router end of all X.21 adapter cables is a high-density, 60-pin plug. The network end of the adapter cable is a standard DB-15 connector. [Figure 1-8](#) shows the connectors at the network end of the X.21 adapter cable. X.21 cables are available as either DTE (DB-15 plug) or DCE (DB-15 receptacle).

**Figure 1-8** X.21 Adapter Cable Connectors

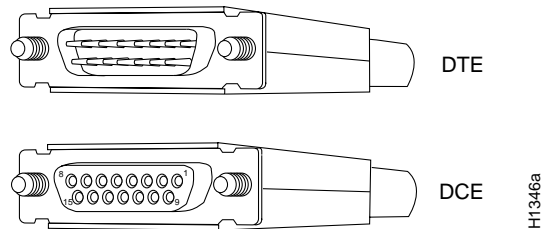

## EIA-530 Connections

The EIA-530 adapter cable is available in DTE mode only. The router end of the EIA-530 adapter cable is a high-density, 60-pin plug. The network end of the adapter cable is a standard DB-25 plug commonly used for EIA/TIA-232 connections. [Figure 1-9](#) shows the DB-25 connector at the network end of the adapter cable.

**Figure 1-9** EIA-530 Adapter Cable Connector

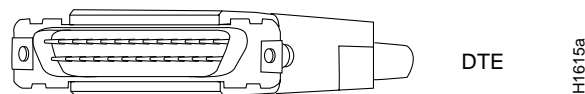

## PA-4T+ Port Adapter Cable Pinouts

All PA-4T+ ports use a 60-pin receptacle that supports all available interface types. A special serial adapter cable determines the electrical interface type and mode of the interface. The router end of all of the adapter cables has a 60-pin plug; the connectors at the network end are the standard connectors used for the respective interfaces. All interface types except EIA-530 are available in DTE or DCE format: DTE with a plug at the network end and DCE with a receptacle at the network end. V.35 is available in either mode with either gender at the network end. EIA-530 is available in DTE only. The tables that follow list the signal pinouts for both the DTE and DCE mode serial port adapter cables for each of the following PA-4T+ interface types:

- EIA/TIA-232 pinouts, [Table 1-3](#)
- EIA/TIA-449 pinouts, [Table 1-5](#)
- EIA-530 pinouts, [Table 1-6](#)
- V.35 pinouts, [Table 1-7](#)
- X.21 pinouts, [Table 1-8](#)

Table 1-3 EIA/TIA-232 Adapter Cable Signals

DTE Cable (CAB-232MT=)				DCE Cable (CAB-232FC=)					
Router End, HD <sup>1</sup> 60-Position Plug				Network End, DB-25 Plug	Router End, HD 60-Position Plug				Network End, DB-25 Receptacle
Signal	Pin		Pin	Signal	Signal	Pin		Pin	Signal
Shield ground	46		1	Shield ground	Shield ground	46		1	Shield ground
TxD/RxD	41	—>	2	TxD	RxD/TxD	36	<—	2	TxD
RxD/TxD	36	<—	3	RxD	TxD/RxD	41	—>	3	RxD
RTS/CTS	42	—>	4	RTS	CTS/RTS	35	<—	4	RTS
CTS/RTS	35	<—	5	CTS	RTS/CTS	42	—>	5	CTS
DSR/DTR	34	<—	6	DSR	DTR/DSR	43	—>	6	DSR
Circuit ground	45		7	Circuit ground	Circuit ground	45		7	Circuit ground
DCD/LL	33	<—	8	DCD	LL/DCD	44	—>	8	DCD
TxC/NIL	37	<—	15	TxC	TxCE/TxC	39	—>	15	TxC
RxC/TxCE	38	<—	17	RxC	NIL/RxC	40	—>	17	RxC
LL/DCD	44	—>	18	LTST	DCD/LL	33	<—	18	LTST
DTR/DSR	43	—>	20	DTR	DSR/DTR	34	<—	20	DTR
TxCE/TxC	39	—>	24	TxCE	RxC/TxCE	38	<—	24	TxCE
Mode 0 Ground Mode_DCE	50 51 52			Shorting group	Mode 0 Ground	50 51			Shorting group

1. HD = high density.

Table 1-4 Intermediate Adapter Cable Signals (for Connecting a PA-4T+ to a NEC - NEXTSTAR 1E Model C4969 MD/SAC Unit)

Router (DTE) End, DB-25 Receptacle				Network (DCE) End, DB-25 Plug
Signal	Pin		Pin	Signal
Shield ground	1		1	Shield ground

**Table 1-4 Intermediate Adapter Cable Signals (for Connecting a PA-4T+ to a NEC - NEXTSTAR 1E Model C4969 MD/SAC Unit) (continued)**

Router (DTE) End, DB-25 Receptacle				Network (DCE) End, DB-25 Plug
Signal	Pin		Pin	Signal
TxD	2	—>	2	TxD
RxD	3	<—	3	RxD
RTS	4	—>	4	RTS
CTS	5	<—	5	CTS
DSR	6	<—	6	DSR
Circuit ground	7		7	Circuit ground
DCD	8	<—	8	DCD
TxC, RxC	15, 17	<—	15	TxC
—	—	<—	17	RxC
LTST	18	—>	18	LTST
DTR	20	—>	20	DTR
TxCE	24	—>	24	TxCE
Shorting group				Shorting group

Table 1-5 EIA/TIA-449 Adapter Cable Signals

DTE Cable (CAB-449MT=)				DCE Cable (CAB-449C=)					
Router End, HD <sup>1</sup> 60-Position Plug				Network End, DB-37 Plug	Router End, HD 60-Position Plug				Network End, DB-37 Receptacle
Signal	Pin		Pin	Signal	Signal	Pin		Pin	Signal
Shield ground	46		1	Shield ground	Shield ground	46		1	Shield ground
TxD/RxD+	11	→	4	SD+	RxD/TxD+	28	←	4	SD+
TxD/RxD-	12	→	22	SD-	RxD/TxD-	27	←	22	SD-
TxC/RxC+	24	←	5	ST+	TxCE/TxC+	13	→	5	ST+
TxC/RxC-	23	←	23	ST-	TxCE/TxC-	14	→	23	ST-
RxD/TxD+	28	←	6	RD+	TxD/RxD+	11	→	6	RD+
RxD/TxD-	27	←	24	RD-	TxD/RxD-	12	→	24	RD-
RTS/CTS+	9	→	7	RS+	CTS/RTS+	1	←	7	RS+
RTS/CTS-	10	→	25	RS-	CTS/RTS-	2	←	25	RS-
RxC/TxCE+	26	←	8	RT+	TxC/RxC+	24	→	8	RT+
RxC/TxCE-	25	←	26	RT-	TxC/RxC-	23	→	26	RT-
CTS/RTS+	1	←	9	CS+	RTS/CTS+	9	→	9	CS+
CTS/RTS-	2	←	27	CS-	RTS/CTS-	10	→	27	CS-
LL/DCD	44	→	10	LL	NIL/LL	29	→	10	LL
Circuit ground	45		37	SC	Circuit ground	30		37	SC
DSR/DTR+	3	←	11	ON+	DTR/DSR+	7	→	11	ON+
DSR/DTR-	4	←	29	ON-	DTR/DSR-	8	→	29	ON-
DTR/DSR+	7	→	12	TR+	DSR/DTR+	3	←	12	TR+
DTR/DSR-	8	→	30	TR-	DSR/DTR-	4	←	30	TR-
DCD/DCD+	5	←	13	RR+	DCD/DCD+	5	→	13	RR+
DCD/DCD-	6	←	31	RR-	DCD/DCD-	6	→	31	RR-
TxCE/TxC+	13	→	17	TT+	RxC/TxCE+	26	←	17	TT+
TxCE/TxC-	14	→	35	TT-	RxC/TxCE-	25	←	35	TT-
Circuit ground	15		19	SG	Circuit ground	15		19	SG
Circuit ground	16		20	RC	Circuit ground	16		20	RC
Mode 1 Ground	49 48			Shorting group	Mode 1 Ground	49 48			Shorting group
Ground Mode_DCE	51 52			Shorting group					

1. HD = high density.



Table 1-6 EIA-530 DTE Adapter Cable Signals (CAB-530MT=)

Router End, HD <sup>1</sup> 60-Position Plug				Network End, DB-25 Plug
Signal	Pin		Pin	Signal
Shield ground	46		1	Shield ground
TxD/RxD+	11	—>	2	TxD+
TxD/RxD-	12	—>	14	TxD-
RxD/TxD+	28	<—	3	RxD+
RxD/TxD-	27	<—	16	RxC-
RTS/CTS+	9	—>	4	RTS+
RTS/CTS-	10	—>	19	RTS-
CTS/RTS+	1	<—	5	CTS+
CTS/RTS-	2	<—	13	CTS-
DSR/DTR+	3	<—	6	DSR+
DSR/DTR-	4	<—	22	DSR-
DCD/DCD+	5	<—	8	DCD+
DCD/DCD-	6	<—	10	DCD-
TxC/RxC+	24	<—	15	TxC+
TxC/RxC-	23	<—	12	TxC-
RxC/TxCE+	26	<—	17	RxC+
RxC/TxCE-	25	<—	9	RxC-
LL/DCD	44	—>	18	LL
Circuit ground	45		7	Circuit ground
DTR/DSR+	7	—>	20	DTR+
DTR/DSR-	8	—>	23	DTR-
TxCE/TxC+	13	—>	24	TxCE+
TxCE/TxC-	14	—>	11	TxCE-
Mode_1	49			Shorting group
Ground	48			
Mode_2	47			
Ground	51			Shorting group
Mode_DCE	52			

1. HD = high density.

Table 1-7 V.35 Adapter Cable Signals

DTE Cable (CAB-V35FT= or CAB-V35MT=)				DCE Cable (CAB-V35FC= or CAB-V35MC=)					
Router End, HD <sup>1</sup> 60-Position Plug				Network End, 34-Position Plug	Router End, HD 60-Position Plug				Network End, 34-Position Receptacle
Signal	Pin		Pin	Signal	Signal	Pin		Pin	Signal
Shield ground	46		A	Frame ground	Shield ground	46		A	Frame ground
Circuit ground	45		B	Circuit ground	Circuit ground	45		B	Circuit ground
RTS/CTS	42	—>	C	RTS	CTS/RTS	35	<—	C	RTS
CTS/RTS	35	<—	D	CTS	RTS/CTS	42	—>	D	CTS
DSR/DTR	34	<—	E	DSR	DTR/DSR	43	—>	E	DSR
DCD/LL	33	<—	F	RLSD	LL/DCD	44	—>	F	RLSD
DTR/DSR	43	—>	H	DTR	DSR/DTR	34	<—	H	DTR
LL/DCD	44	—>	K	LT	DCD/LL	33	<—	K	LT
TxD/RxD+	18	—>	P	SD+	RxD/TxD+	28	<—	P	SD+
TxD/RxD-	17	—>	S	SD-	RxD/TxD-	27	<—	S	SD-
RxD/TxD+	28	<—	R	RD+	TxD/RxD+	18	—>	R	RD+
RxD/TxD-	27	<—	T	RD-	TxD/RxD-	17	—>	T	RD-
TxCE/TxC+	20	—>	U	SCTE+	RxC/TxCE+	26	<—	U	SCTE+
TxCE/TxC-	19	—>	W	SCTE-	RxC/TxCE-	25	<—	W	SCTE-
RxC/TxCE+	26	<—	V	SCR+	NIL/RxC+	22	—>	V	SCR+
RxC/TxCE-	25	<—	X	SCR-	NIL/RxC-	21	—>	x	SCR-
TxC/RxC+	24	<—	Y	SCT+	TxCE/TxC+	20	—>	Y	SCT+
TxC/RxC-	23	<—	AA	SCT-	TxCE/TxC-	19	—>	AA	SCT-
Mode 1 Ground	49 48			Shorting group	Mode 1 Ground	49 48			Shorting group
Mode 0 Ground Mode_DCE	50 51 52			Shorting group	Mode 0 Ground	50 51			Shorting group
TxC/NIL RxC/TxCE RxC/TxD Ground	53 54 55 56			Shorting group	TxC/NIL RxC/TxCE RxC/TxD Ground	53 54 55 56			Shorting group

1. HD = high density.

Table 1-8 X.21 Adapter Cable Signals

DTE Cable (CAB-X21MT=)				DCE Cable (CAB-X21FC=)					
Router End, HD <sup>1</sup> 60-Position Plug			Network End, DB-15 Plug	Router End, HD 60-Position Plug				Network End, DB-15 Receptacle	
Signal	Pin		Pin	Signal	Signal	Pin		Pin	Signal
Shield ground	46		1	Shield ground	Shield ground	46		1	Shield ground
TxD/RxD+	11	—>	2	Transmit+	RxD/TxD+	11	—>	2	Transmit+
TxD/RxD-	12	—>	9	Transmit-	RxD/TxD-	12	—>	9	Transmit-
RTS/CTS+	9	—>	3	Control+	CTS/RTS+	9	—>	3	Control+
RTS/CTS -	10	—>	10	Control-	CTS/RTS -	10	—>	10	Control-
RxD/TxD+	28	<—	4	Receive+	TxD/RxD+	28	<—	4	Receive+
RxD/TxD-	27	<—	11	Receive-	TxD/RxD-	27	<—	11	Receive-
CTS/RTS+	1	<—	5	Indication+	RTS/CTS+	1	<—	5	Indication+
CTS/RTS -	2	<—	12	Indication-	RTS/CTS-	2	<—	12	Indication-
RxC/TxCE+	26	<—	6	Timing+	TxC/RxC+	26	<—	6	Timing+
RxC/TxCE-	25	<—	13	Timing-	TxC/RxC -	25	<—	13	Timing-
Circuit ground	15		8	Circuit ground	Circuit ground	15		8	Circuit ground
Ground Mode_2	48 47			Shorting group	Ground Mode_2	48 47			Shorting group
Ground Mode_DCE	51 52			Shorting group	Ground Mode_DCE	51 52			

1. HD = high density.

## Port Adapter Slot Locations on the Supported Platforms

This section discusses port adapter slot locations on the supported platforms. The illustrations that follow summarize slot location conventions on each platform:

- [Catalyst RSM/VIP2 Slot Numbering, page 1-16](#)
- [Catalyst 6000 Family FlexWAN Module Slot Numbering, page 1-16](#)
- [Cisco 7100 Series Routers Slot Numbering, page 1-17](#)
- [Cisco 7200 Series Routers and Cisco 7200 VXR Routers Slot Numbering, page 1-18](#)
- [Cisco 7201 Router Slot Numbering, page 1-21](#)
- [Cisco 7301 Router Slot Numbering, page 1-21](#)
- [Cisco 7304 PCI Port Adapter Carrier Card Slot Numbering, page 1-22](#)
- [Cisco 7401ASR Router Slot Numbering, page 1-23](#)
- [Cisco 7000 Series Routers and Cisco7500 Series Routers VIP Slot Numbering, page 1-23](#)

## Catalyst RSM/VIP2 Slot Numbering

The Catalyst RSM/VIP2 can be installed in any slot in a Catalyst 5000 family switch except the top slots, which contain the supervisor engines. The Catalyst RSM/VIP2 in a Catalyst 5000 family switch does not use interface processor slot numbering; therefore, slots are not numbered. The PA-4T+ can be installed into either port adapter slot 0 or slot 1 on a Catalyst RSM/VIP2. [Figure 1-10](#) shows a Catalyst RSM/VIP2 with two port adapters installed.



### Note

The Catalyst 5500 switch has 13 slots. Slot 1 is reserved for the supervisor engine. If a redundant supervisor engine is used, it would go in slot 2; otherwise, slot 2 can be used for other modules. Slot 13 is a dedicated slot, reserved for the ATM Switch Processor (ASP) module. Refer to the *Catalyst 5000 Series Route Switch Module Installation and Configuration Note* for any additional slot restrictions for the Catalyst RSM/VIP2.

**Figure 1-10** Catalyst 5000 Family Switch with Port Adapters Installed on Catalyst RSM/VIP2

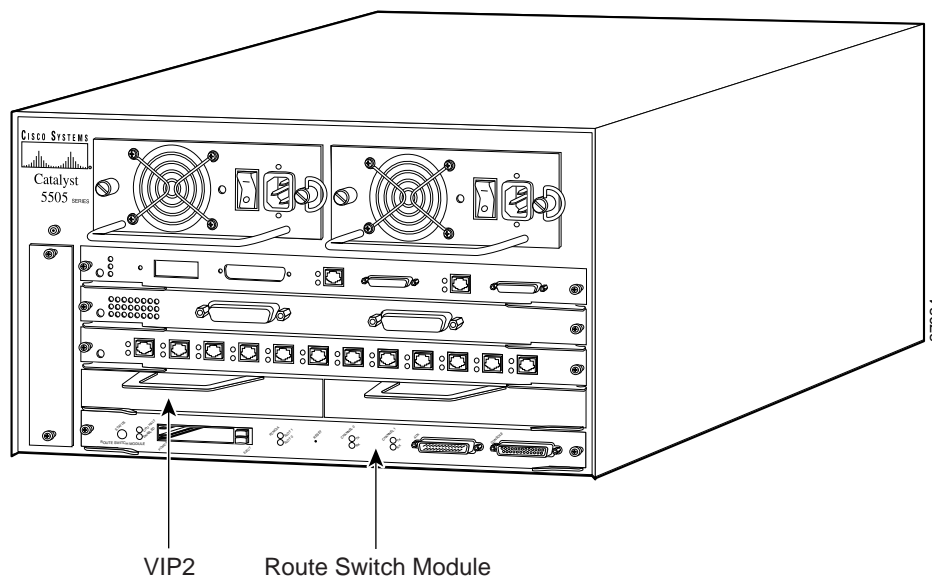

## Catalyst 6000 Family FlexWAN Module Slot Numbering

The Catalyst 6000 family FlexWAN module can be installed in any slot in a Catalyst 6000 family switch except slot 1, which is reserved for the supervisor engine. The PA-4T+ can be installed into either port adapter bay 0 or bay 1 on a FlexWAN module. [Figure 1-11](#) shows a FlexWAN module with two blank port adapters installed.



### Note

Slot 1 is reserved for the supervisor engine. If a redundant supervisor engine is used, it would go in slot 2; otherwise, slot 2 can be used for other modules.

Figure 1-11 Catalyst 6000 Family Switch with Port Adapters Installed on FlexWAN Module

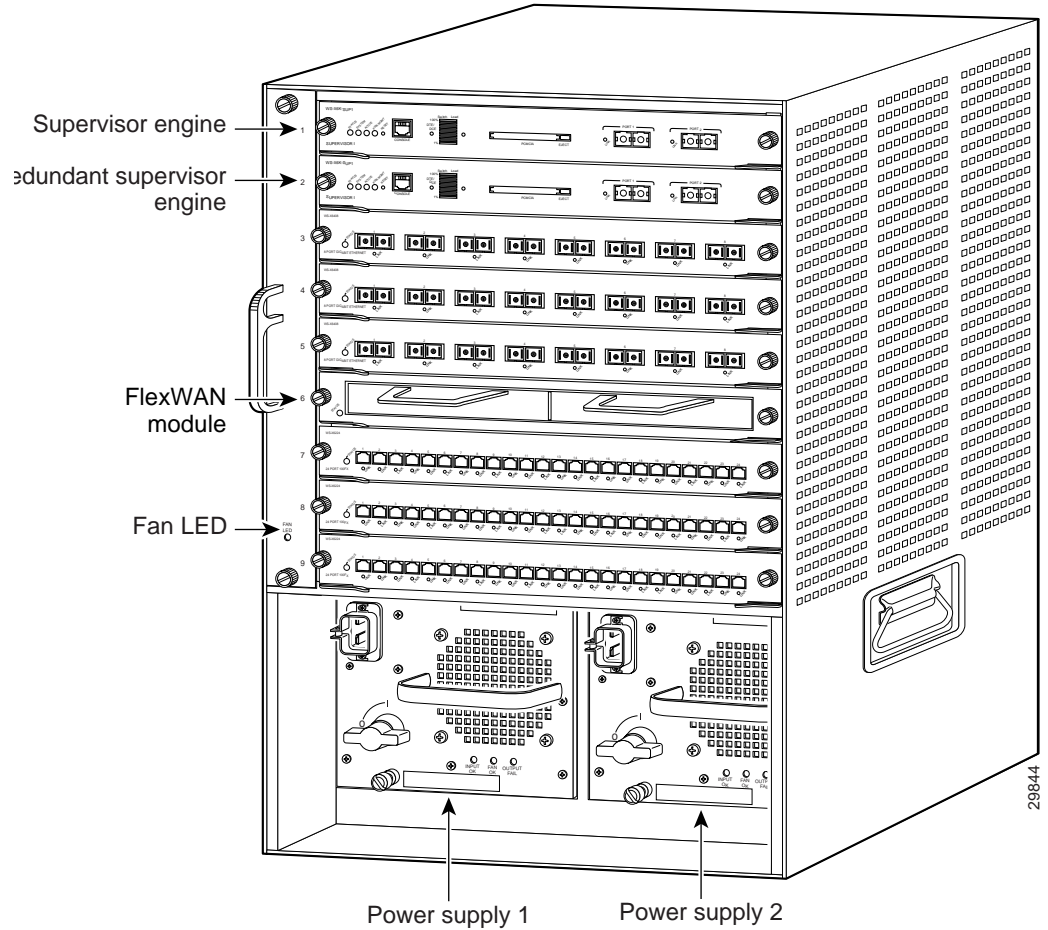

## Cisco 7100 Series Routers Slot Numbering

The PA-4T+ can be installed in port adapter slot 3 in Cisco 7120 series routers, and in port adapter slot 4 in Cisco 7140 series routers. [Figure 1-12](#) shows the slot numbering on a Cisco 7120 series router. [Figure 1-13](#) shows the slot numbering on a Cisco 7140 series router.

Figure 1-12 Port Adapter Slots in the Cisco 7120 Series Router

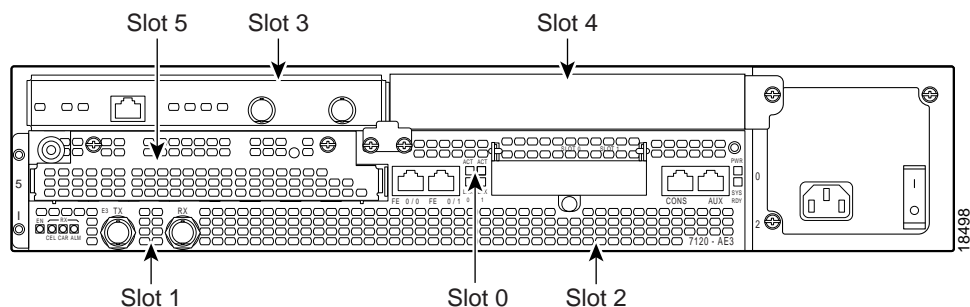

**Figure 1-13** Port Adapter Slots in the Cisco 7140 Series Router

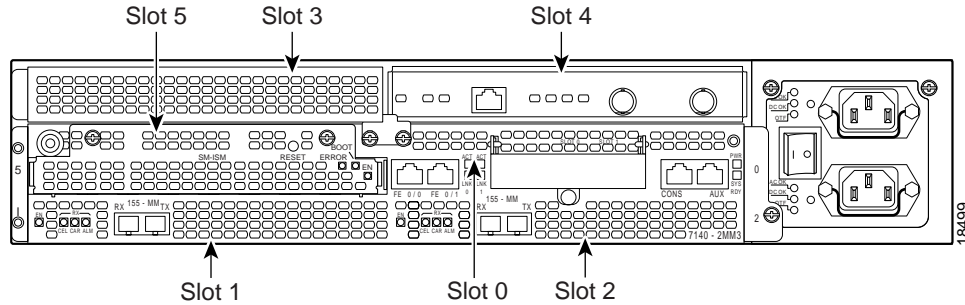

## Cisco 7200 Series Routers and Cisco 7200 VXR Routers Slot Numbering

Cisco 7202 routers have two port adapter slots. The slots are numbered from left to right. You can place a port adapter in either of the slots (slot 1 or slot 2). The Cisco 7202 router is not shown.

Cisco 7204 routers and Cisco 7204VXR routers have four slots for port adapters, and one slot for an input/output (I/O) controller. The slots are numbered from the lower left to the upper right, beginning with slot 1 and continuing through slot 4. You can place a port adapter in any of the slots (slot 1 through slot 4). Slot 0 is always reserved for the I/O controller. The Cisco 7204 router and Cisco 7204VXR router are not shown.

Cisco 7206 routers and Cisco 7206VXR routers (including the Cisco 7206 and Cisco 7206VXR as router shelves in a Cisco AS5800 Universal Access Server) have six slots for port adapters, and one slot for an input/output (I/O) controller. The slots are numbered from the lower left to the upper right, beginning with slot 1 and continuing through slot 6. You can place a port adapter in any of the six slots (slot 1 through slot 6). Slot 0 is always reserved for the I/O controller. Figure 1-14 shows the slot numbering on a Cisco 7206 router. The Cisco 7206VXR router is not shown.

**Figure 1-14** Port Adapter Slots in the Cisco 7206 Router

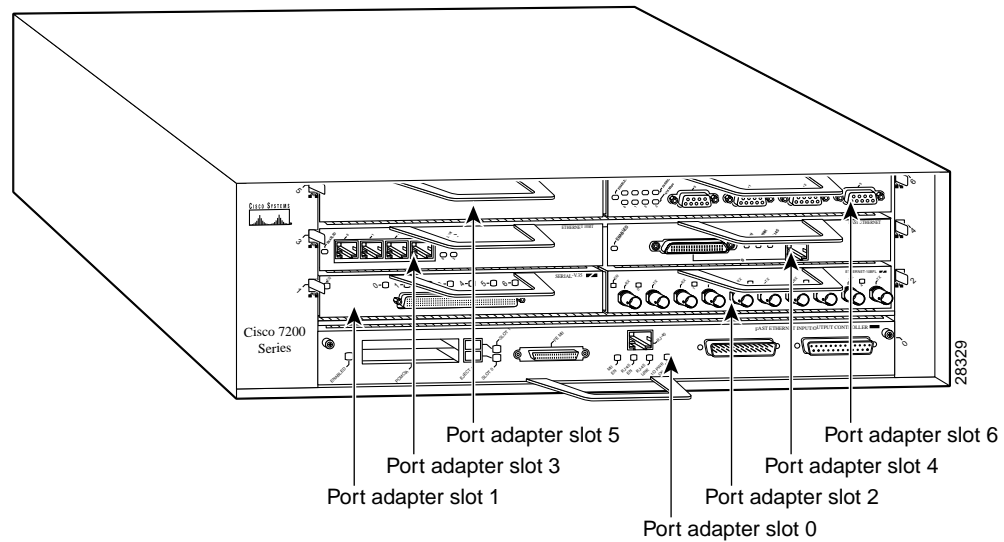

## Cisco uBR7200 Series Router Slot Numbering

The Cisco uBR7223 router has one port adapter slot (slot 1). Slot 0 is always reserved for the I/O controller—if present. The Cisco uBR7223 router is not shown.

The Cisco uBR7246 router and Cisco uBR7246VXR router have two port adapter slots (slot 1 and slot 2). Slot 0 is always reserved for the I/O controller—if present. [Figure 1-15](#) shows the slot numbering of port adapters on a Cisco uBR7246 router or Cisco uBR7246VXR router.

**Figure 1-15** Port Adapter Slots in the Cisco uBR7246 and Cisco uBR7246VXR Routers

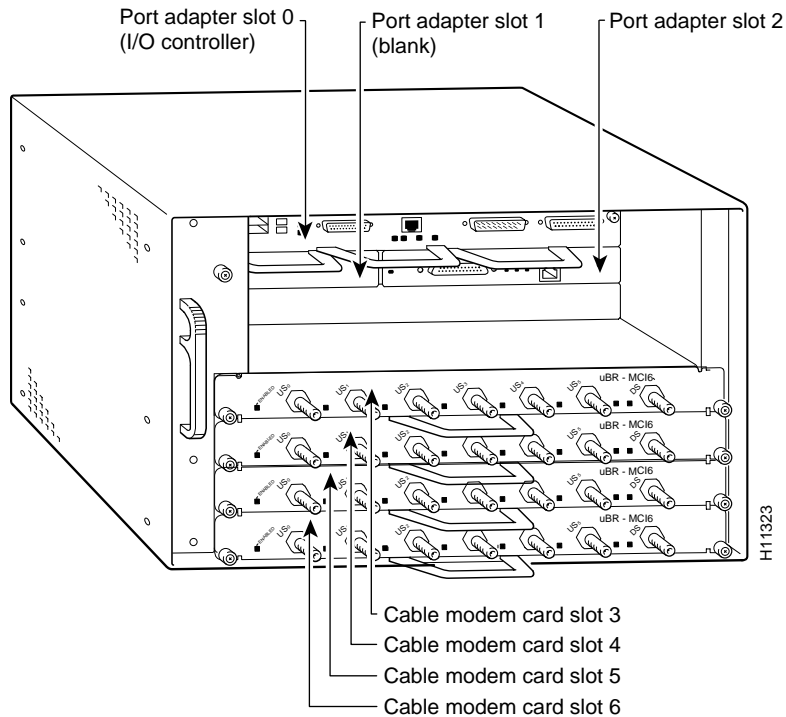



## Cisco 7201 Router Slot Numbering

Figure 1-16 shows the front view of a Cisco 7201 router with a port adapter installed. There is only one port adapter slot (slot 1) in a Cisco 7201 router.

**Figure 1-16** Port Adapter Slot in the Cisco 7201 Router

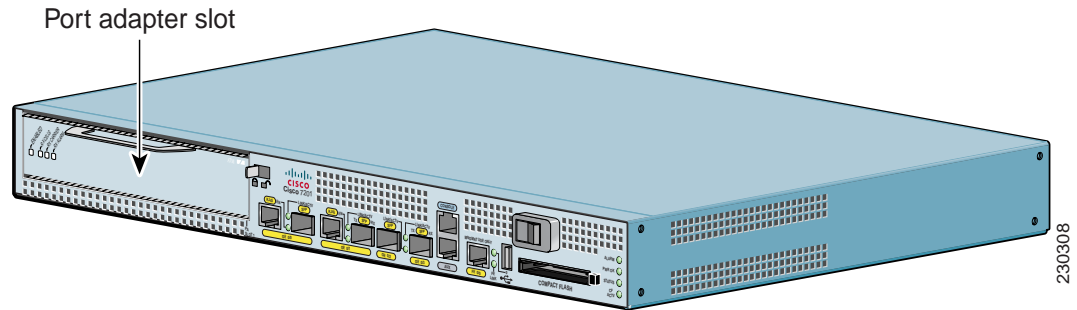

## Cisco 7301 Router Slot Numbering

Figure 1-17 shows the front view of a Cisco 7301 router with a port adapter installed. There is only one port adapter slot (slot 1) in a Cisco 7301 router.

**Figure 1-17** Port Adapter Slot in a Cisco 7301 Router

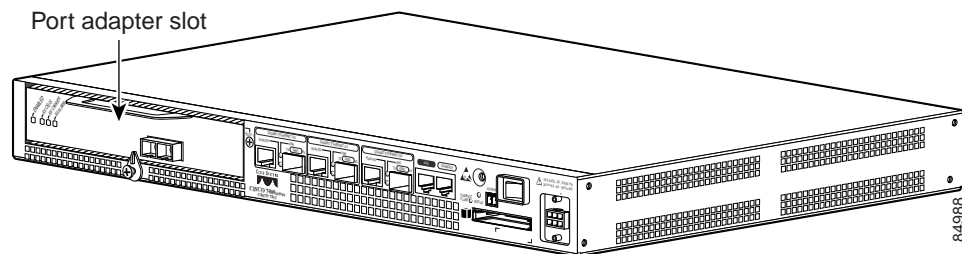

## Cisco 7304 PCI Port Adapter Carrier Card Slot Numbering

The Cisco 7304 PCI Port Adapter Carrier Card installs in Cisco 7304 router module slots 2 through 5. [Figure 1-18](#) shows a Cisco 7304 PCI Port Adapter Carrier Card with a port adapter installed. The Cisco 7304 PCI Port Adapter Carrier Card accepts one single-width port adapter.

[Figure 1-19](#) shows the module slot numbering on a Cisco 7304 router. The port adapter slot number is the same as the module slot number. Slot 0 and slot 1 are reserved for the NPE module or NSE module

**Figure 1-18** Cisco 7304 PCI Port Adapter Carrier Card—Port Adapter Installed

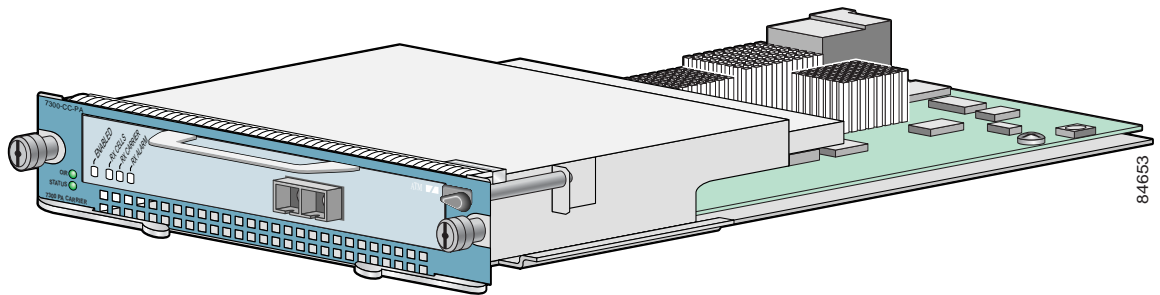

**Figure 1-19** Module Slots on the Cisco 7304 Router

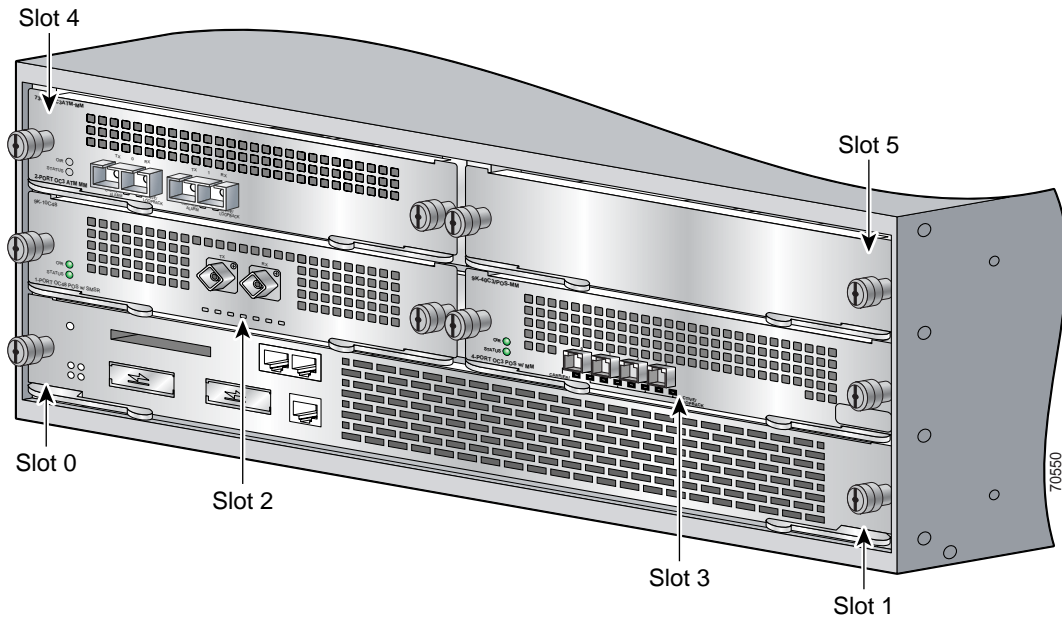

## Cisco 7401ASR Router Slot Numbering

Figure 1-20 shows the front view of a Cisco 7401ASR router with a port adapter installed. There is only one port adapter slot (slot 1) in a Cisco 7401ASR router.

**Figure 1-20** Port Adapter Slot in the Cisco 7401ASR Router

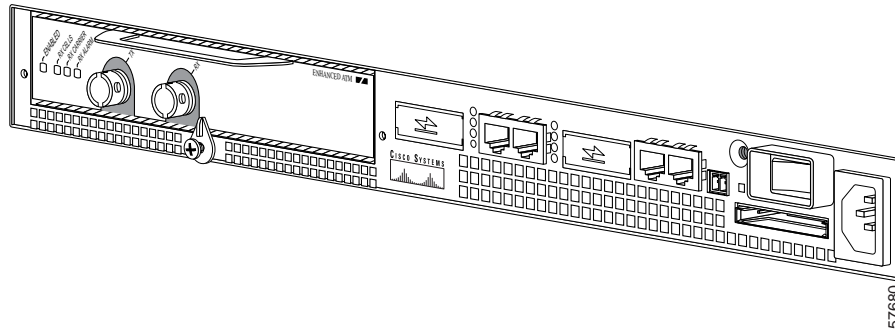

## Cisco 7000 Series Routers and Cisco 7500 Series Routers VIP Slot Numbering

Port adapters are supported on the VIPs (versatile interface processors) used in Cisco 7000 series and Cisco 7500 series routers. In the Cisco 7010 router and Cisco 7505 router, the VIP motherboard is installed horizontally in the VIP slot. In the Cisco 7507 router and Cisco 7513 router, the VIP motherboard is installed vertically in the VIP slot. A port adapter can be installed in either bay (port adapter slot 0 or 1) on the VIP. The bays are numbered from left to right on the VIP. Figure 1-21 shows the slot numbering on a VIP.

**Figure 1-21** VIP Slot Locations—Horizontal Orientation

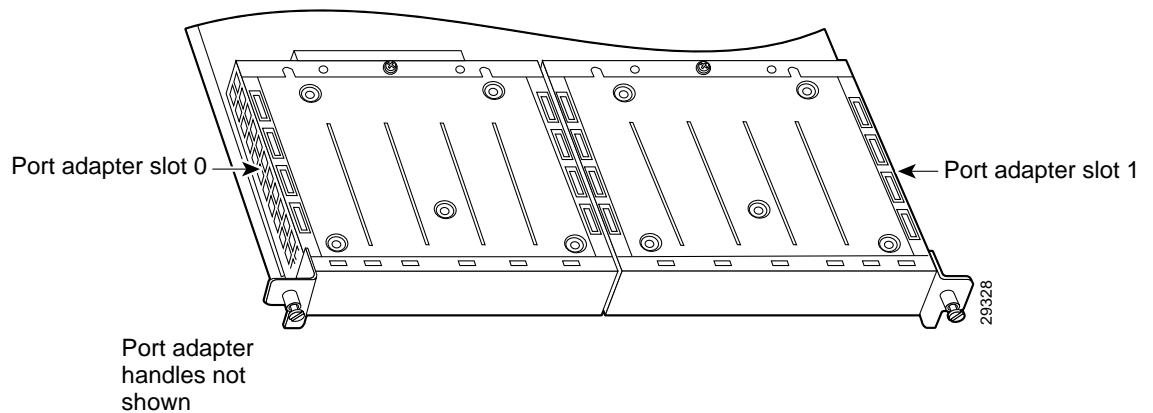

Cisco 7010 routers have three slots for port adapters, and two slots for Route Switch Processors (RSPs). The slots are numbered from bottom to top. You can place a port adapter in any of the VIP interface slots (slot 0 through 2). Slots 3 and 4 are always reserved for RSPs. The Cisco 7010 router is not shown.

Cisco 7505 routers have four slots for port adapters, and one slot for an RSP. The slots are numbered from bottom to top. You can place a port adapter in any of the VIP interface slots (slot 0 through 3). One slot is always reserved for the RSP. [Figure 1-22](#) shows the slot numbering on a Cisco 7505 router.

**Figure 1-22** VIP Slots in the Cisco 7505 Router

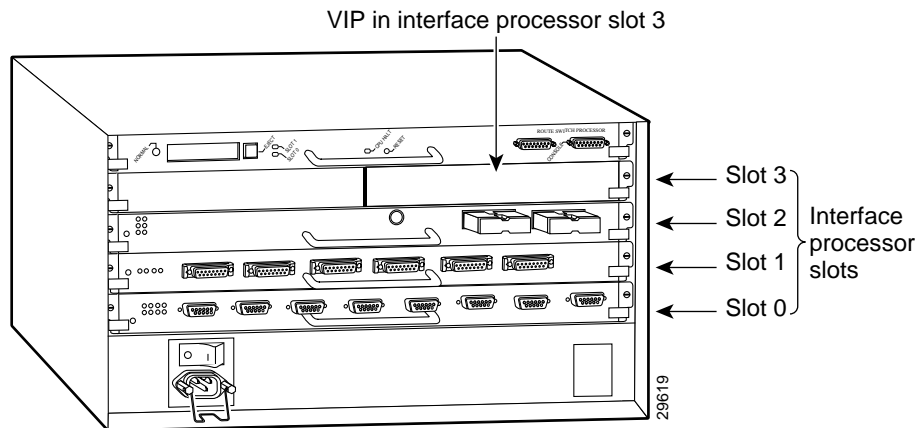

Cisco 7507 routers have five slots for port adapters, and two slots for RSPs. The slots are numbered from left to right. You can place a port adapter in any of the VIP interface slots (slot 0, 1, 4, 5, or 6). Slots 2 and 3 are always reserved for RSPs. The Cisco 7507 router is not shown.

Cisco 7513 routers have eleven slots for port adapters, and two slots for RSPs. The slots are numbered from left to right. You can place a port adapter in any of the VIP interface slots (slots 0 through 5, or slots 9 through 12). Slots 6 and 7 are always reserved for RSPs. The Cisco 7513 router is not shown.

# Identifying Interface Addresses

This section describes how to identify interface addresses for the PA-4T+ in supported platforms. Interface addresses specify the actual physical location of each interface on a router or switch.

Interfaces on a PA-4T+ installed in a router maintain the same address regardless of whether other port adapters are installed or removed. However, when you move a port adapter to a different slot, the first number in the interface address changes to reflect the new port adapter slot number.

Interfaces on a PA-4T+ installed in a VIP or FlexWAN module maintain the same address regardless of whether other interface processors or modules are installed or removed. However, when you move a VIP or FlexWAN module to a different slot, the interface processor or module slot number changes to reflect the new interface processor or module slot.



**Note**

Interface ports are numbered from left to right starting with 0.

The following subsections describe the interface address formats for the supported platforms:

- [Catalyst RSM/VIP2 Interface Addresses, page 1-26](#)
- [Catalyst 6000 Family FlexWAN Module, page 1-27](#)
- [Cisco 7100 Series Routers Interface Addresses, page 1-27](#)
- [Cisco 7200 Series Routers and Cisco 7200 VXR Routers Interface Addresses, page 1-27](#)
- [Cisco uBR7200 Series Routers Interface Addresses, page 1-28](#)
- [Cisco 7201 Router Interface Addresses, page 1-28](#)
- [Cisco 7301 Router Interface Addresses, page 1-28](#)
- [Cisco 7304 PCI Port Adapter Carrier Card Interface Addresses, page 1-28](#)
- [Cisco 7401ASR Router Interface Addresses, page 1-28](#)
- [Cisco 7000 Series Routers and Cisco 7500 Series Routers VIP Interface Addresses, page 1-29](#)

Table 1-9 summarizes the interface address formats for the supported platforms.

**Table 1-9**      *Identifying Interface Addresses*

Platform	Interface Address Format	Numbers	Syntax
Catalyst RSM/VIP2 in Catalyst 5000 family switches	Port-adapter-slot-number/interface-port-number	Port adapter slot— 0 or 1 Interface port—0 through 3	0/1
Catalyst 6000 family FlexWAN module in Catalyst 6000 family switches	Module-slot-number/port-adapter-bay-number/ interface-port-number	Module slot—2 <sup>1</sup> through 13 (depends on the number of slots in the switch) Port adapter bay— 0 or 1 Interface port—0 through 3	3/0/0
Cisco 7120 series router	Port-adapter-slot-number/interface-port-number	Port adapter slot—always 3 Interface port—0 through 3	3/1
Cisco 7140 series router	Port-adapter-slot-number/interface-port-number	Port adapter slot—always 4 Interface port—0 through 3	4/0

Table 1-9 Identifying Interface Addresses (continued)

Platform	Interface Address Format	Numbers	Syntax
Cisco 7200 series routers and Cisco 7200 VXR routers	Port-adapter-slot-number/interface-port-number	Port adapter slot—1 through 6 (depends on the number of slots in the router) <sup>2</sup> Interface port—0 through 3	1/0
Cisco 7201 router	Port-adapter-slot-number/interface-port-number	Port adapter slot—always 1 Interface port—0 through 3	1/0
Cisco uBR7223 router	Port-adapter-slot-number/interface-port-number	Port adapter slot—always 1 <sup>2</sup> Interface port—0 through 3	1/0
Cisco uBR7246 and Cisco uBR7246VXR routers	Port-adapter-slot-number/interface-port-number	Port adapter slot—1 or 2 <sup>2</sup> Interface port—0 through 3	1/2
Cisco 7301 router	Port-adapter-slot-number/interface-port-number	Port adapter slot—always 1 Interface port—0 through 3	1/0
Cisco 7304 PCI Port Adapter Carrier Card in Cisco 7304 router	Module-slot-number/interface-port-number	Module slot— 2 through 5 Interface port—0 through 3	3/0
Cisco 7401ASR router	Port-adapter-slot-number/interface-port-number	Port adapter slot—always 1 Interface port—0 through 3	1/0
VIP in Cisco 7000 series routers or Cisco 7500 series routers	Interface-processor-slot-number/port-adapter-slot-number/interface-port-number	Interface processor slot—0 through 12 (depends on the number of slots in the router) Port adapter slot— 0 or 1 Interface port—0 through 3	3/1/0

1. Slot 1 is reserved for the supervisor engine. If a redundant supervisor engine is used, it must go in slot 2; otherwise, slot 2 can be used for other modules.
2. Port adapter slot 0 is reserved for the Fast Ethernet port on the I/O controller (if present).

## Catalyst RSM/VIP2 Interface Addresses

In Catalyst 5000 family switches, the Catalyst RSM/VIP2 can be installed in any slot except the top slots, which contain the supervisor engine modules. The Catalyst RSM/VIP2 in a Catalyst 5000 family switch does not use interface processor slot numbering; therefore, the slots in which it is installed are not numbered. A port adapter can be installed into either port adapter slot 0 or slot 1 on a Catalyst RSM/VIP2. See [Figure 1-10](#).

The interface address is composed of a two-part number in the format *port-adapter-slot number/interface-port number*. See [Table 1-9](#).

For example, if the four-port PA-4T+ is installed in a VIP in interface processor slot 1, port adapter slot 1, the interface addresses would be 1/1/0, 1/1/1, 1/1/2, and 1/1/3 (interface processor slot 1, port adapter slot 1, and interfaces 0, 1, 2, and 3).

## Catalyst 6000 Family FlexWAN Module

In Catalyst 6000 family switches, the Catalyst 6000 family FlexWAN module can be installed in module slots 2 through 13 (depending on the number of slots in the router). Slot 1 is reserved for the supervisor engine. A port adapter can be installed into either port adapter bay 0 or bay 1 on a FlexWAN module. See [Figure 1-11](#).

The interface address is composed of a three-part number in the format *module-number/port-adapter-bay-number/interface-port-number*. See [Table 1-9](#).

The first number identifies the module slot of the chassis in which the FlexWAN module is installed (slot 2 through slot 3, 6, 9, or 13 depending on the number of slots in the chassis). These module slots are generally numbered from top to bottom, starting with 1.

The second number identifies the bay of the FlexWAN module in which the port adapter is installed (0 or 1). The bays are numbered from left to right on the FlexWAN module.

The third number identifies the physical port number on the port adapter. The PA-4T+ is a four-port port adapter, therefore the port can be 0 through 3.

For example, if a four-port PA-4T+ is installed in a FlexWAN module in module slot 3, port adapter bay 0, then the interface addresses are 3/0/0 through 3/0/3 (module slot 3, port adapter bay 0, and interfaces 0 through 3). If the port adapter was in port adapter bay 1 on the FlexWAN module, these same interface addresses would be numbered 3/1/0 through 3/1/3.

**Note**

The FlexWAN module physical port address begins with slot 0, which differs from the conventional Catalyst 6000 family port address, which begins with slot 1.

## Cisco 7100 Series Routers Interface Addresses

In Cisco 7120 series router, port adapters are installed in port adapter slot 3. See [Figure 1-12](#). In the Cisco 7140 series router, port adapters are installed in port adapter slot 4. See [Figure 1-13](#).

The interface address is composed of a two-part number in the format *port-adapter-slot-number/interface-port-number*. See [Table 1-9](#). For example, if a four-port PA-4T+ is installed on a Cisco 7120 router, the interface addresses would be 3/0 through 3/3. If a four-port PA-4E1G is installed on a Cisco 7140 router, the interface addresses would be 4/0 through 4/3.

## Cisco 7200 Series Routers and Cisco 7200 VXR Routers Interface Addresses

In Cisco 7200 series routers and Cisco 7200 VXR routers, port adapter slots are numbered from the lower left to the upper right, beginning with slot 1 and continuing through slot 2 for the Cisco 7202, slot 4 for the Cisco 7204 and Cisco 7204VXR, and slot 6 for the Cisco 7206 and Cisco 7206VXR. Port adapters can be installed in any available port adapter slot from 1 through 6 (depending on the number of slots in the router). (Slot 0 is reserved for the I/O controller.) See [Figure 1-14](#).

The interface address is composed of a two-part number in the format *port-adapter-slot-number/interface-port-number*. See [Table 1-9](#). For example, if a four-port PA-4T+ is installed in slot 1 of a Cisco 7200 series router, the interface addresses would be 1/0 through 1/3.

## Cisco uBR7200 Series Routers Interface Addresses

In the Cisco uBR7223 router, only one slot accepts port adapters and it is numbered slot 1.

In the Cisco uBR7246 router and Cisco uBR7246VXR router, port adapters can be installed in two port adapter slots (slot1 and slot 2). Slot 0 is always reserved for the I/O controller—if present. See [Figure 1-15](#).

The interface address is composed of a two-part number in the format *port-adapter-slot-number/interface-port-number*. See [Table 1-9](#). For example, if a four-port PA-4T+ is installed in slot 1 of a Cisco uBR7223 series router, the interface addresses would be 1/0 through 1/3. If a four-port PA-4T+ is installed in slot 2 of a Cisco uBR7246 or Cisco uBR7246VXR router, the interface addresses would be 2/0 through 2/3.

## Cisco 7201 Router Interface Addresses

In the Cisco 7201 router, only one slot accepts port adapters and it is numbered as slot 1. See [Figure 1-16](#).

The interface address is composed of a two-part number in the format *port-adapter-slot-number/interface-port-number*. See [Table 1-9](#). For example, if a four-port PA-4T+ is installed in a Cisco 7201 router, the interface addresses would be 1/0 through 1/3.

## Cisco 7301 Router Interface Addresses

In the Cisco 7301 router, only one slot accepts port adapters and it is numbered as slot 1. See [Figure 1-17](#).

The interface address is composed of a two-part number in the format *port-adapter-slot-number/interface-port-number*. See [Table 1-9](#). For example, if a four-port PA-4T+ is installed in a Cisco 7301 router, the interface addresses would be 1/0 through 1/3.

## Cisco 7304 PCI Port Adapter Carrier Card Interface Addresses

In the Cisco 7304 router, port adapters are installed in a Cisco 7304 PCI port adapter carrier card, which installs in Cisco 7304 router module slots 2 through 5. The port adapter slot number is the same as the module slot number. See [Figure 1-18](#) and [Figure 1-19](#).

The interface address is composed of a two-part number in the format *module-slot-number/interface-port-number*. See [Table 1-9](#). For example, if a four-port PA-4T+ is installed in the Cisco 7304 PCI port adapter carrier card in Cisco 7304 router module slot 3, the interface addresses would be 3/0 through 3/3.

## Cisco 7401ASR Router Interface Addresses

In the Cisco 7401ASR router, only one slot accepts port adapters and it is numbered as slot 1. See [Figure 1-20](#).

The interface address is composed of a two-part number in the format *port-adapter-slot-number/interface-port-number*. See [Table 1-9](#). For example, if a four-port PA-4T+ is installed in a Cisco 7401ASR router, the interface addresses would be 1/0 through 1/3.



## Cisco 7000 Series Routers and Cisco 7500 Series Routers VIP Interface Addresses

In Cisco 7000 series routers and Cisco 7500 series routers, port adapters are installed on a versatile interface processor (VIP), which installs in interface processor slots 0 through 12 (depending on the number of slots in the router). The port adapter can be installed in either bay (port adapter slot 0 or 1) on the VIP. See [Figure 1-21](#), and [Figure 1-22](#).

The interface address for the VIP is composed of a three-part number in the format *interface-processor-slot-number/port-adapter-slot-number/interface-port-number*. See [Table 1-9](#).

The first number identifies the slot in which the VIP is installed (slot 0 through 12, depending on the number of slots in the router).

The second number identifies the bay (port adapter slot) on the VIP in which the port adapter is installed (0 or 1). The bays are numbered from left to right on the VIP.

The third number identifies the physical port number (interface port number) on the port adapter. The port numbers always begin at 0 and are numbered from left to right. The number of additional ports depends on the number of ports on the port adapter. The PA-4T+ is a four-port port adapter, therefore the port can be 0 through 3.

For example, if a four-port PA-4T+ is installed in a VIP in interface processor slot 3, port adapter slot 1, the interface addresses would be 3/1/0 through 3/1/3 (interface processor slot 3, port adapter slot 1, and interfaces 0, 1, 2 and 3).

**Note**

---

Although the processor slots in the 7-slot Cisco 7000 router and Cisco 7507 router and the 13-slot Cisco 7513 router and Cisco 7576 router are vertically oriented and those in the 5-slot Cisco 7010 router and Cisco 7505 router are horizontally oriented, all Cisco 7000 series routers and Cisco 7500 series routers use the same method for slot and port numbering.

---





## CHAPTER 2

# Preparing for Installation

---

This chapter describes the general equipment, safety, and site preparation requirements for installing the PA-4T+. This chapter contains the following sections:

- [Required Tools and Equipment, page 2-1](#)
- [Software and Hardware Requirements, page 2-2](#)
- [Checking Hardware and Software Compatibility, page 2-3](#)
- [Safety Guidelines, page 2-3](#)
- [FCC Class A Compliance, page 2-10](#)

## Required Tools and Equipment

You need the following tools and parts to install a PA-4T+. If you need additional equipment, contact a service representative for ordering information.

- PA-4T+
- Catalyst RSM/VIP2 (for installation in the Catalyst 5000 family switches). For information about the specific VIP2 models that support the PA-4T+, see the [“Software and Hardware Requirements” section on page 2-2](#).
- Catalyst 6000 family FlexWAN module (for installation in the Catalyst 6000 family switches)
- VIP (for installation in Cisco 7000 series or Cisco 7500 series chassis only)
- Cisco 7304 PCI Port Adapter Carrier Card (for installation in a Cisco 7304 router)
- Serial cables appropriate for the desired port adapter interface types and the desired modes. (See the [“Cables, Connectors, and Pinouts” section on page 1-5](#).)
- Number 1 Phillips and a 3/16-inch flat-blade screwdriver (for VIP installation only)
- Number 2 Phillips screwdriver
- Your own electrostatic discharge (ESD)-prevention equipment or the disposable grounding wrist strap included with all upgrade kits, field-replaceable units (FRUs), and spares
- Antistatic mat
- Antistatic container

# Software and Hardware Requirements

Table 2-1 lists the recommended minimum Cisco IOS software release required to use the PA-4T+ in supported router or switch platforms.

**Table 2-1 PA-4T+ Software Requirements**

Platform	Recommended Minimum Cisco IOS Release
<b>Catalyst 5000 family switches with Catalyst RSM/VIP2</b> <ul style="list-style-type: none"> <li>With Catalyst RSM/VIP2-15(=) or Catalyst RSM/VIP2-40(=)<sup>1</sup></li> </ul>	Cisco IOS Release 11.2(9)P or a later release of Cisco IOS Release 11.2P
<b>Catalyst 6000 family switches with Catalyst 6000 family FlexWAN module</b> <ul style="list-style-type: none"> <li>Catalyst 6000 family MSFC</li> <li>Supervisor engine software</li> </ul>	Cisco IOS Release 12.1(1)EX or later Catalyst 6000 Family supervisor engine software release 5.4(1) or later
<b>Cisco 7100 series routers</b> <ul style="list-style-type: none"> <li>Cisco 7120 series and Cisco 7140 series</li> </ul>	Cisco IOS Release 12.0(4)XE or a later release of Cisco IOS Release 12.0XE Cisco IOS Release 12.0(5)T or a later release of Cisco IOS Release 12.0T
<b>Cisco 7200 series and Cisco 7200 VXR routers</b> <ul style="list-style-type: none"> <li>Cisco 7204VXR and Cisco 7206VXR</li> <li>Cisco 7204 and Cisco 7206</li> <li>Cisco 7202</li> </ul>	Cisco IOS Release 12.0(3)T or a later release of Cisco IOS Release 12.0T Cisco IOS Release 12.0(2)XE2 or a later release of Cisco IOS Release 12.0XE Cisco IOS Release 12.2(4)B or a later release of Cisco IOS Release 12.2B Cisco IOS Release 11.1(6)CA or a later release of Cisco IOS Release 11.1CA <sup>2</sup> Cisco IOS Release 12.2(4)B or a later release of Cisco IOS Release 12.2B Cisco IOS Release 11.1(19)CC1 or a later release of Cisco IOS Release 11.1CC Cisco IOS Release 11.3(4)AA or a later release of Cisco IOS Release 11.3AA Cisco IOS Release 12.2(4)B or a later release of Cisco IOS Release 12.2B
<b>Cisco uBR7200 series routers</b>	Cisco IOS Release 11.3(6)NA or a later release of Cisco IOS Release 11.3NA
<b>Cisco 7201 router</b>	Cisco IOS Release 12.4(4)XD7 or a later release of Cisco IOS Release 12.4XD Cisco IOS Release 12.2(31)SB5 or a later release of Cisco IOS Release 12.2SB
<b>Cisco 7301 router</b>	Cisco IOS Release 12.2(11)YZ or a later release of Cisco IOS Release 12.2 YZ
<b>Cisco 7304 router</b> With Cisco 7304 PCI Port Adapter Carrier Card	Cisco IOS Release 12.2(14)SZ or a later release of Cisco IOS Release 12.2SZ
<b>Cisco 7401ASR router</b>	Cisco IOS Release 12.2(1)DX or a later release of Cisco IOS Release 12.2DX Cisco IOS Release 12.2(4)B or a later release of Cisco IOS Release 12.2B
<b>VIP in the Cisco 7000 series and Cisco 7500 series routers</b>	Cisco IOS Release 11.1(8)CA or a later release of Cisco IOS Release 11.1CA Cisco IOS Release 11.1(14)CA or a later release of Cisco IOS Release 11.1CA

- If you are installing only one PA-4T+, you can use the Catalyst RSM/VIP2-15(=); otherwise, we recommend the Catalyst RSM/VIP2-40(=).
- For PA-4T+ port adapters installed in Cisco 7200 series routers, Cisco IOS Release 11.1(6)CA, or later, is required; however, we recommend Cisco IOS Release 11.1(8)CA or later.

**Note**

Cisco IOS Release 11.2(7a)P or later supports half-duplex and binary synchronous communications (Bisync) operation on the PA-4T+ in Cisco 7200 series routers.

**Caution**

To prevent system problems, the VIP requires that Cisco 7000 series routers have the RSP7000 and RSP7000CI installed. The VIP will not operate properly with the Route Processor (RP), Switch Processor (SP), or Silicon Switch Processor (SSP) installed in a Cisco 7000 series router.

For configuration guidelines on port adapters in the Cisco 7200 series, refer to the *Cisco 7200 Series Port Adapter Hardware Configuration Guidelines* at the following URL:

[http://www.cisco.com/en/US/products/hw/modules/ps2033/products\\_configuration\\_guide\\_book09186a00801056ef.html](http://www.cisco.com/en/US/products/hw/modules/ps2033/products_configuration_guide_book09186a00801056ef.html)

## Checking Hardware and Software Compatibility

To check the minimum software requirements of Cisco IOS software with the hardware installed on your router, Cisco maintains the Software Advisor tool on Cisco.com. This tool does not verify whether modules within a system are compatible, but it does provide the minimum IOS requirements for individual hardware modules or components.

**Note**

Access to this tool is limited to users with Cisco.com login accounts.

To access Software Advisor, click **Log In** at Cisco.com and go to Support > Tools and Resources. You can also access the tool by pointing your browser directly to

[http://www.cisco.com/en/US/support/tsd\\_most\\_requested\\_tools.html](http://www.cisco.com/en/US/support/tsd_most_requested_tools.html).

Choose a product family or enter a specific product number to search for the minimum supported software release needed for your hardware.

## Safety Guidelines

This section provides safety guidelines that you should follow when working with any equipment that connects to electrical power or telephone wiring.

## Safety Warnings

Safety warnings appear throughout this publication in procedures that, if performed incorrectly, may harm you. A warning symbol precedes each warning statement.



Warning

**IMPORTANT SAFETY INSTRUCTIONS**

This warning symbol means danger. You are in a situation that could cause bodily injury. Before you work on any equipment, be aware of the hazards involved with electrical circuitry and be familiar with standard practices for preventing accidents. To see translations of the warnings that appear in this publication, refer to the translated safety warnings that accompanied this device.

Note: **SAVE THESE INSTRUCTIONS**

Note: This documentation is to be used in conjunction with the specific product installation guide that shipped with the product. Please refer to the Installation Guide, Configuration Guide, or other enclosed additional documentation for further details.

Waarschuwing

**BELANGRIJKE VEILIGHEIDSINSTRUCTIES**

Dit waarschuwingssymbool betekent gevaar. U verkeert in een situatie die lichamelijk letsel kan veroorzaken. Voordat u aan enige apparatuur gaat werken, dient u zich bewust te zijn van de bij elektrische schakelingen betrokken risico's en dient u op de hoogte te zijn van de standaard praktijken om ongelukken te voorkomen. Voor een vertaling van de waarschuwingen die in deze publicatie verschijnen, dient u de vertaalde veiligheidswaarschuwingen te raadplegen die bij dit apparaat worden geleverd.

Opmerking **BEWAAR DEZE INSTRUCTIES.**

Opmerking Deze documentatie dient gebruikt te worden in combinatie met de installatiehandleiding voor het specifieke product die bij het product wordt geleverd. Raadpleeg de installatiehandleiding, configuratiehandleiding of andere verdere ingesloten documentatie voor meer informatie.

Varoitus

**TÄRKEITÄ TURVALLISUUTEEN LIITTYVIÄ OHJEITA**

Tämä varoitusmerkki merkitsee vaaraa. Olet tilanteessa, joka voi johtaa ruumiinvammaan. Ennen kuin työskentelet minkään laitteiston parissa, ota selvää sähkökytkentöihin liittyvistä vaaroista ja tavanomaisista onnettomuuksien ehkäisykeinoista. Tässä asiakirjassa esitettyjen varoitusten käännökset löydät laitteen mukana toimitetuista ohjeista.

Huomautus **SÄILYTÄ NÄMÄ OHJEET**

Huomautus Tämä asiakirja on tarkoitettu käytettäväksi yhdessä tuotteen mukana tulleen asennusoppaan kanssa. Katso lisätietoja asennusoppaasta, kokoonpano-oppaasta ja muista mukana toimitetuista asiakirjoista.

**Attention**    **IMPORTANTES INFORMATIONS DE SÉCURITÉ**

Ce symbole d'avertissement indique un danger. Vous vous trouvez dans une situation pouvant causer des blessures ou des dommages corporels. Avant de travailler sur un équipement, soyez conscient des dangers posés par les circuits électriques et familiarisez-vous avec les procédures couramment utilisées pour éviter les accidents. Pour prendre connaissance des traductions d'avertissements figurant dans cette publication, consultez les consignes de sécurité traduites qui accompagnent cet appareil.

**Remarque**    **CONSERVEZ CES INFORMATIONS**

**Remarque** Cette documentation doit être utilisée avec le guide spécifique d'installation du produit qui accompagne ce dernier. Veuillez vous reporter au Guide d'installation, au Guide de configuration, ou à toute autre documentation jointe pour de plus amples renseignements.

**Warnung**    **WICHTIGE SICHERHEITSANWEISUNGEN**

Dieses Warnsymbol bedeutet Gefahr. Sie befinden sich in einer Situation, die zu einer Körperverletzung führen könnte. Bevor Sie mit der Arbeit an irgendeinem Gerät beginnen, seien Sie sich der mit elektrischen Stromkreisen verbundenen Gefahren und der Standardpraktiken zur Vermeidung von Unfällen bewusst. Übersetzungen der in dieser Veröffentlichung enthaltenen Warnhinweise sind im Lieferumfang des Geräts enthalten.

**Hinweis**    **BEWAHREN SIE DIESE SICHERHEITSANWEISUNGEN AUF**

**Hinweis** Dieses Handbuch ist zum Gebrauch in Verbindung mit dem Installationshandbuch für Ihr Gerät bestimmt, das dem Gerät beiliegt. Entnehmen Sie bitte alle weiteren Informationen dem Handbuch (Installations- oder Konfigurationshandbuch o. Ä.) für Ihr spezifisches Gerät.

**Figyelem!**    **FONTOS BIZTONSÁGI ELŐÍRÁSOK**

Ez a figyelmeztető jel veszélyre utal. Sérülésveszélyt rejtő helyzetben van. Mielőtt bármely berendezésen munkát végezte, legyen figyelemmel az elektromos áramkörök okozta kockázatokra, és ismerkedjen meg a szokásos balesetvédelmi eljárásokkal. A kiadványban szereplő figyelmeztetések fordítása a készülékhez mellékelt biztonsági figyelmeztetések között található.

**Megjegyzés**    **ŐRIZZE MEG EZEKET AZ UTASÍTÁSOKAT!**

**Megjegyzés** Ezt a dokumentációt a készülékhez mellékelt üzembe helyezési útmutatóval együtt kell használni. További tudnivalók a mellékelt Üzembe helyezési útmutatóban (Installation Guide), Konfigurációs útmutatóban (Configuration Guide) vagy más dokumentumban találhatók.

**Avvertenza**    **IMPORTANTI ISTRUZIONI SULLA SICUREZZA**

Questo simbolo di avvertenza indica un pericolo. La situazione potrebbe causare infortuni alle persone. Prima di intervenire su qualsiasi apparecchiatura, occorre essere al corrente dei pericoli relativi ai circuiti elettrici e conoscere le procedure standard per la prevenzione di incidenti. Per le traduzioni delle avvertenze riportate in questo documento, vedere le avvertenze di sicurezza che accompagnano questo dispositivo.

**Nota**    **CONSERVARE QUESTE ISTRUZIONI**

**Nota** La presente documentazione va usata congiuntamente alla guida di installazione specifica spedita con il prodotto. Per maggiori informazioni, consultare la Guida all'installazione, la Guida alla configurazione o altra documentazione acclusa.

**Advarsel VIKTIGE SIKKERHETSINSTRUKSJONER**

Dette varselssymbolet betyr fare. Du befinner deg i en situasjon som kan forårsake personskade. Før du utfører arbeid med utstyret, bør du være oppmerksom på farene som er forbundet med elektriske kretssystemer, og du bør være kjent med vanlig praksis for å unngå ulykker. For å se oversettelser av advarslene i denne publikasjonen, se de oversatte sikkerhetsvarslene som følger med denne enheten.

**Merk TA VARE PÅ DISSE INSTRUKSJONENE**

Merk Denne dokumentasjonen skal brukes i forbindelse med den spesifikke installasjonsveiledningen som fulgte med produktet. Vennligst se installasjonsveiledningen, konfigureringsveiledningen eller annen vedlagt tilleggsdokumentasjon for detaljer.

**Aviso INSTRUÇÕES IMPORTANTES DE SEGURANÇA**

Este símbolo de aviso significa perigo. O utilizador encontra-se numa situação que poderá ser causadora de lesões corporais. Antes de iniciar a utilização de qualquer equipamento, tenha em atenção os perigos envolvidos no manuseamento de circuitos eléctricos e familiarize-se com as práticas habituais de prevenção de acidentes. Para ver traduções dos avisos incluídos nesta publicação, consulte os avisos de segurança traduzidos que acompanham este dispositivo.

**Nota GUARDE ESTAS INSTRUÇÕES**

Nota Esta documentação destina-se a ser utilizada em conjunto com o manual de instalação incluído com o produto específico. Consulte o manual de instalação, o manual de configuração ou outra documentação adicional inclusa, para obter mais informações.

**¡Advertencia! INSTRUCCIONES IMPORTANTES DE SEGURIDAD**

Este símbolo de aviso indica peligro. Existe riesgo para su integridad física. Antes de manipular cualquier equipo, considere los riesgos de la corriente eléctrica y familiarícese con los procedimientos estándar de prevención de accidentes. Vea las traducciones de las advertencias que acompañan a este dispositivo.

**Nota GUARDE ESTAS INSTRUCCIONES**

Nota Esta documentación está pensada para ser utilizada con la guía de instalación del producto que lo acompaña. Si necesita más detalles, consulte la Guía de instalación, la Guía de configuración o cualquier documentación adicional adjunta.

**Varning! VIKTIGA SÄKERHETSANVISNINGAR**

Denna varningssignal signalerar fara. Du befinner dig i en situation som kan leda till personskada. Innan du utför arbete på någon utrustning måste du vara medveten om farorna med elkretsar och känna till vanliga förfaranden för att förebygga olyckor. Se översättningarna av de varningsmeddelanden som finns i denna publikation, och se de översatta säkerhetsvarningarna som medföljer denna anordning.

**OBS! SPARA DESSA ANVISNINGAR**

OBS! Denna dokumentation ska användas i samband med den specifika produktinstallationshandbok som medföljde produkten. Se installationshandboken, konfigurationshandboken eller annan bifogad ytterligare dokumentation för närmare detaljer.



**Предупреждение**    **ВАЖНЫЕ СВЕДЕНИЯ ПО БЕЗОПАСНОСТИ**

Этот символ предупреждает о наличии опасности. При неправильных действиях возможно получение травм. Перед началом работы с любым оборудованием необходимо ознакомиться с ситуациями, в которых возможно поражение электротоком, и со стандартными действиями для предотвращения несчастных случаев. Переведенный текст предупреждений содержится в соответствующем документе, поставляемом вместе с устройством.

Примечание    **СОХРАНЯЙТЕ ЭТУ ИНСТРУКЦИЮ**

Примечание    Эта инструкция должна использоваться вместе с руководством по установке конкретного изделия, входящим в комплект поставки. Дополнительные сведения см. в руководстве по установке, руководстве по настройке и другой документации, поставляемой с изделием.

**警告**    有关安全的重要说明

这个警告符号指有危险。您所处的环境可能使身体受伤。操作设备前必须意识到电流的危险性，务必熟悉操作标准，以防发生事故。如果需要了解本说明中出现的警告符号的译文，请参阅本装置所附之安全警告译文。

注意    保存这些说明

注意    本文件应与本产品附带的具体安装说明一并阅读。如欲了解详情，请参阅《安装说明》、《配置说明》或所附的其他文件。

**警告**    安全上の重要な注意事項

「危険」の意味です。人身事故を予防するための注意事項が記述されています。装置の取り扱い作業を行うときは、電気回路の危険性に注意し、一般的な事故防止対策に留意してください。このマニュアルに記載されている警告の各国語版は、装置に付属の「Translated Safety Warnings」を参照してください。

注    これらの注意事項を保管しておいてください。

注    この資料は、製品に付属のインストレーション ガイドと併用してください。詳細は、インストレーション ガイド、コンフィギュレーション ガイド、または添付されているその他のマニュアルを参照してください。

**Предупреждение** ВАЖНЫЕ СВЕДЕНИЯ ПО БЕЗОПАСНОСТИ

Этот символ предупреждает о наличии опасности. При неправильных действиях возможно получение травм. Перед началом работы с любым оборудованием необходимо ознакомиться с ситуациями, в которых возможно поражение электротоком, и со стандартными действиями для предотвращения несчастных случаев. Переведенный текст предупреждений содержится в соответствующем документе, поставляемом вместе с устройством.

Примечание СОХРАНЯЙТЕ ЭТУ ИНСТРУКЦИЮ

Примечание Эта инструкция должна использоваться вместе с руководством по установке конкретного изделия, входящим в комплект поставки. Дополнительные сведения см. в руководстве по установке, руководстве по настройке и другой документации, поставляемой с изделием.

**警告** 有关安全的重要说明

这个警告符号指有危险。您所处的环境可能使身体受伤。操作设备前必须意识到电流的危险性，务必熟悉操作标准，以防发生事故。如果需要了解本说明中出现的警告符号的译文，请参阅本装置所附之安全警告译文。

注意 保存这些说明

注意 本文件应与本产品附带的具体安装说明一并阅读。如欲了解详情，请参阅《安装说明》、《配置说明》或所附的其他文件。

**警告** 安全上の重要な注意事項

「危険」の意味です。人身事故を予防するための注意事項が記述されています。装置の取り扱い作業を行うときは、電気回路の危険性に注意し、一般的な事故防止対策に留意してください。このマニュアルに記載されている警告の各国語版は、装置に付属の「Translated Safety Warnings」を参照してください。

注 これらの注意事項を保管しておいてください。

注 この資料は、製品に付属のインストラクション ガイドと併用してください。詳細は、インストラクション ガイド、コンフィギュレーション ガイド、または添付されているその他のマニュアルを参照してください。

## Electrical Equipment Guidelines

Follow these basic guidelines when working with any electrical equipment:

- Before beginning any procedures requiring access to the chassis interior, locate the emergency power-off switch for the room in which you are working.
- Disconnect all power and external cables before moving a chassis.
- Do not work alone when potentially hazardous conditions exist.
- Never assume that power has been disconnected from a circuit; always check.

- Do not perform any action that creates a potential hazard to people or makes the equipment unsafe; carefully examine your work area for possible hazards such as moist floors, ungrounded power extension cables, and missing safety grounds.

## Telephone Wiring Guidelines

Use the following guidelines when working with any equipment that is connected to telephone wiring or to other network cabling:

- Never install telephone wiring during a lightning storm.
- Never install telephone jacks in wet locations unless the jack is specifically designed for wet locations.
- Never touch uninsulated telephone wires or terminals unless the telephone line has been disconnected at the network interface.
- Use caution when installing or modifying telephone lines.

## Preventing Electrostatic Discharge Damage

Electrostatic discharge (ESD) damage, which can occur when electronic cards or components are improperly handled, results in complete or intermittent failures. Port adapters and processor modules comprise printed circuit boards that are fixed in metal carriers. Electromagnetic interference (EMI) shielding and connectors are integral components of the carrier. Although the metal carrier helps to protect the board from ESD, use a preventive antistatic strap during handling.

Following are guidelines for preventing ESD damage:

- Always use an ESD wrist or ankle strap and ensure that it makes good skin contact.
- Connect the equipment end of the strap to an unfinished chassis surface.
- When installing a component, use any available ejector levers or captive installation screws to properly seat the bus connectors in the backplane or midplane. These devices prevent accidental removal, provide proper grounding for the system, and help to ensure that bus connectors are properly seated.
- When removing a component, use any available ejector levers or captive installation screws to release the bus connectors from the backplane or midplane.
- Handle carriers by available handles or edges only; avoid touching the printed circuit boards or connectors.
- Place a removed board component-side-up on an antistatic surface or in a static shielding container. If you plan to return the component to the factory, immediately place it in a static shielding container.
- Avoid contact between the printed circuit boards and clothing. The wrist strap only protects components from ESD voltages on the body; ESD voltages on clothing can still cause damage.
- Never attempt to remove the printed circuit board from the metal carrier.



### Caution

For safety, periodically check the resistance value of the antistatic strap. The measurement should be between 1 and 10 megohms (Mohm).

## FCC Class A Compliance

This equipment has been tested and found to comply with the limits for a Class A digital device, pursuant to part 15 of the FCC rules. These limits are designed to provide reasonable protection against harmful interference when the equipment is operated in a commercial environment. This equipment generates, uses, and can radiate radio-frequency energy and, if not installed and used in accordance with the instruction manual, may cause harmful interference to radio communications. Operation of this equipment in a residential area is likely to cause harmful interference, in which case users will be required to correct the interference at their own expense.

You can determine whether your equipment is causing interference by turning it off. If the interference stops, it was probably caused by the Cisco equipment or one of its peripheral devices. If the equipment causes interference to radio or television reception, try to correct the interference by using one or more of the following measures:

- Turn the television or radio antenna until the interference stops.
- Move the equipment to one side or the other of the television or radio.
- Move the equipment farther away from the television or radio.
- Plug the equipment into an outlet that is on a different circuit from the television or radio. (That is, make certain the equipment and the television or radio are on circuits controlled by different circuit breakers or fuses.)



---

**Note**

The PA-4T+ has been designed to meet these requirements. Modifications to this product that are not authorized by Cisco Systems, Inc., could void the various approvals and negate your authority to operate the product.

---



# CHAPTER 3

## Removing and Installing Port Adapters

---

This chapter describes how to remove the PA-4T+ port adapter from supported platforms and also how to install a new or replacement port adapter. This chapter contains the following sections:

- [Handling Port Adapters, page 3-1](#)
- [Online Insertion and Removal, page 3-2](#)
- [Warnings and Cautions, page 3-3](#)
- [Port Adapter Removal and Installation, page 3-4](#)

### Handling Port Adapters

Each port adapter circuit board is mounted to a metal carrier and is sensitive to electrostatic discharge (ESD) damage.



**Note**

When a port adapter slot is not in use, a blank port adapter must fill the empty slot to allow the router or switch to conform to electromagnetic interference (EMI) emissions requirements and to allow proper airflow across the port adapters. If you plan to install a new port adapter in a slot that is not in use, you must first remove the blank port adapter.

---



**Caution**

When powering off the router, wait a minimum of 30 seconds before powering it on again.

---



**Caution**

Always handle the port adapter by the carrier edges and handle; never touch the port adapter's components or connector pins. (See [Figure 3-1](#).)

---

Figure 3-1 Handling a Port Adapter

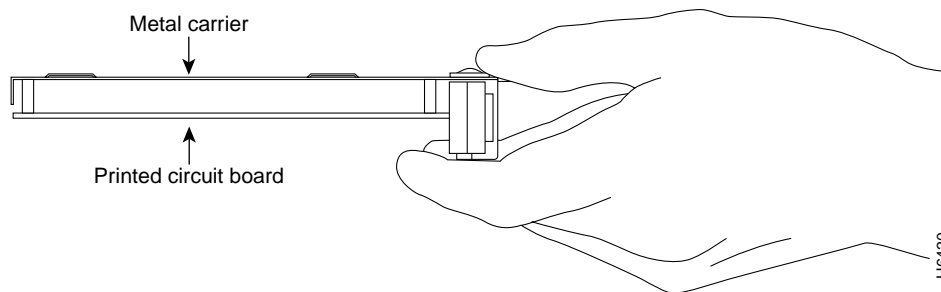

## Online Insertion and Removal

Several platforms support online insertion and removal (OIR) of port adapters; therefore, you do not have to power down routers when removing and replacing a PA-4T+ in the Cisco 7100 series routers, Cisco 7200 series routers, Cisco 7200 VXR routers, Cisco uBR7200 series routers, Cisco 7201 router, Cisco 7301 router, or Cisco 7401ASR router.

Although the Catalyst RSM/VIP2, Catalyst 6000 family FlexWAN module, Cisco 7304 PCI port adapter carrier card, and VIP support OIR, individual port adapters do not. To replace port adapters, you must first remove the Catalyst RSM/VIP2, Catalyst 6000 family FlexWAN module, Cisco 7304 PCI port adapter carrier card, or VIP from the chassis and then install or replace port adapters as required. If a blank port adapter is installed on the Catalyst RSM/VIP2, Catalyst 6000 family FlexWAN module, Cisco 7304 PCI port adapter carrier card, or VIP on which you want to install a new port adapter, you must first remove the Catalyst RSM/VIP2, Catalyst 6000 family FlexWAN module, Cisco 7304 PCI port adapter carrier card, or VIP from the chassis and then remove the blank port adapter.



### Caution

To prevent system problems, do not remove port adapters from the Catalyst RSM/VIP2, Catalyst 6000 family FlexWAN module, Cisco 7304 PCI port adapter carrier card, or VIP or attempt to install other port adapters on the motherboard when the system is operating. To install or replace port adapters, first remove the Catalyst RSM/VIP2, Catalyst 6000 family FlexWAN module, Cisco 7304 PCI port adapter carrier card, or VIP from its interface processor slot.

It is wise to gracefully shut down the system before removing a port adapter that has active traffic moving through it. Removing a port adapter while traffic is flowing through the ports can cause system disruption. Once the port adapter is inserted, the ports can be brought back up.



### Note

As you disengage the port adapter from the router or switch, OIR administratively shuts down all active interfaces in the port adapter.

OIR allows you to install and replace port adapters while the router is operating; you do not need to notify the software or shut down the system power, although you should not run traffic through the port adapter you are removing while it is being removed. OIR is a method that is seamless to end users on the network, maintains all routing information, and preserves sessions.

The following is a functional description of OIR for background information only; for specific procedures for installing and replacing a port adapter in a supported platform, refer to the [“Port Adapter Removal and Installation”](#) section on page 3-4.

Each port adapter has a bus connector that connects it to the router. The connector has a set of tiered pins in three lengths that send specific signals to the system as they make contact with the port adapter. The system assesses the signals it receives and the order in which it receives them to determine if a port adapter is being removed from or introduced to the system. From these signals, the system determines whether to reinitialize a new interface or to shut down a disconnected interface.

Specifically, when you insert a port adapter, the longest pins make contact with the port adapter first, and the shortest pins make contact last. The system recognizes the signals and the sequence in which it receives them.

When you remove or insert a port adapter, the pins send signals to notify the system of changes. The router then performs the following procedure:

1. Rapidly scans the system for configuration changes.
2. Initializes newly inserted port adapters or administratively shuts down any vacant interfaces.
3. Brings all previously configured interfaces on the port adapter back to their previously installed state. Any newly inserted interface is put in the administratively shutdown state, as if it was present (but not configured) at boot time. If a similar port adapter type is reinserted into a slot, its ports are configured and brought online up to the port count of the originally installed port adapter of that type.

**Note**

Before you begin installation, read [Chapter 2, “Preparing for Installation,”](#) for a list of parts and tools required for installation.

## Warnings and Cautions

Observe the following warnings and cautions when installing or removing port adapters.

**Caution**

Do not slide a port adapter all the way into the slot until you have connected all required cables. Trying to do so will disrupt normal operation of the router or switch.

**Note**

If a port adapter lever or other retaining mechanism does not move to the locked position, the port adapter is not completely seated in the midplane. Carefully pull the port adapter halfway out of the slot, reinsert it, and move the port adapter lever to the locked position.

**Caution**

To prevent jamming the carrier between the upper and the lower edges of the port adapter slot, and to ensure that the edge connector at the rear of the port adapter mates with the connection at the rear of the port adapter slot, make certain that the carrier is positioned correctly, as shown in the cutaway illustrations in the [“Port Adapter Removal and Installation”](#) section on page 3-4.

**Warning**

When performing the following procedures, wear a grounding wrist strap to avoid ESD damage to the card. Some platforms have an ESD connector for attaching the wrist strap. Do not directly touch the midplane or backplane with your hand or any metal tool, or you could shock yourself.

# Port Adapter Removal and Installation

In this section, the illustrations that follow give step-by-step instruction on how to remove and install port adapters. This section contains the following illustrations:

- [Catalyst RSM/VIP2—Removing and Installing a Port Adapter, page 3-5](#)
- [Catalyst 6000 Family FlexWAN Module—Removing and Installing a Port Adapter, page 3-6](#)
- [Cisco 7100 Series Routers—Removing and Installing a Port Adapter, page 3-7](#)
- [Cisco 7200 Series Routers and Cisco 7200 VXR Routers—Removing and Installing a Port Adapter, page 3-8](#)
- [Cisco uBR7200 Series Routers—Removing a Port Adapter, page 3-9](#)
- [Cisco uBR7200 Series Routers—Installing a Port Adapter, page 3-10](#)
- [Cisco 7201 Router—Removing and Installing a Port Adapter, page 3-11](#)
- [Cisco 7301 Router—Removing and Installing a Port Adapter, page 3-12](#)
- [Cisco 7304 PCI Port Adapter Carrier Card—Removing and Installing a Port Adapter, page 3-13](#)
- [Cisco 7401ASR Router—Removing and Installing a Port Adapter, page 3-15](#)
- [VIP—Removing and Installing a Port Adapter, page 3-16](#)



## Catalyst RSM/VIP2—Removing and Installing a Port Adapter

Note: You must first remove the Catalyst RSM/VIP2 from the chassis before removing a port adapter from the Catalyst RSM/VIP2.

### Step 1

To remove the port adapter, remove the screw that secures the port adapter (or blank port adapter). (See A.)

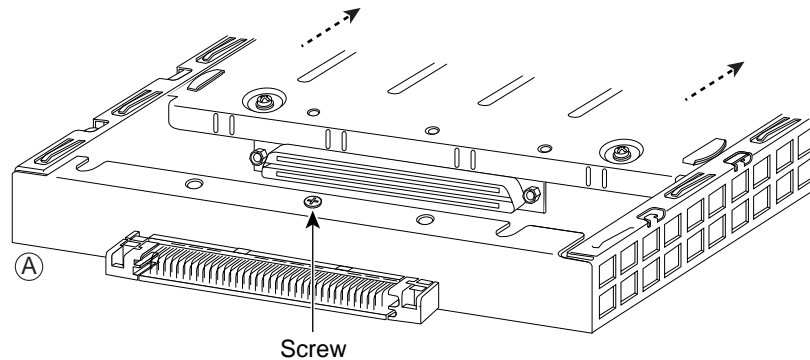

### Step 2

With the screw removed, grasp the handle on the front of the port adapter (or blank port adapter) and carefully pull it out of its slot, away from the edge connector at the rear of the slot. (See A.)

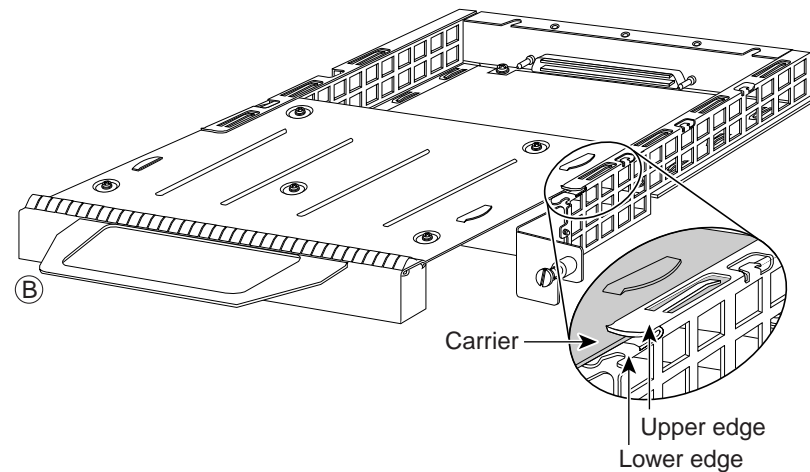

### Step 3

To install the port adapter, carefully align the port adapter carrier between the upper and the lower edges of the port adapter slot. (See B.)

### Step 4

Install the screw in the rear of the port adapter slot. Do not overtighten the screw. (See A.)

### Step 5

Carefully slide the new port adapter into the port adapter slot until the connector on the port adapter is completely seated in the connector at the rear of the port adapter slot. (See B.)

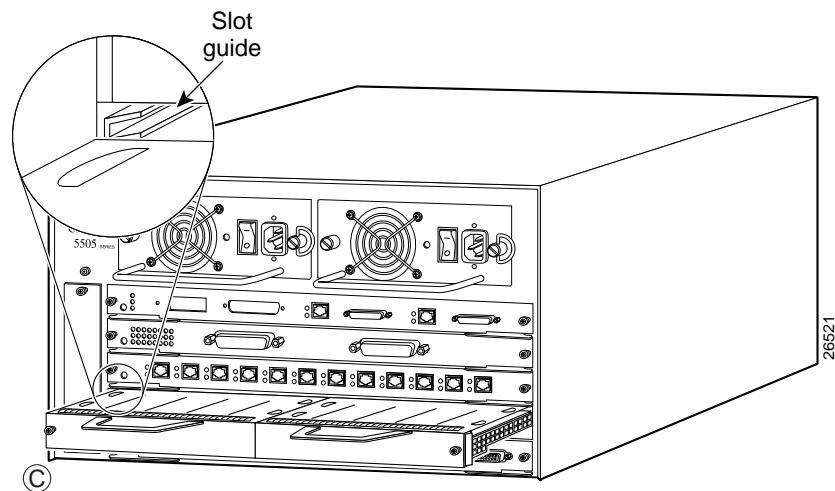

### Step 6

Reinstall the Catalyst RSM/VIP2 motherboard in the chassis and tighten the captive installation screw on each side of the Catalyst RSM/VIP2 faceplate. (See C.)

## Catalyst 6000 Family FlexWAN Module—Removing and Installing a Port Adapter

Note: You must first remove the Catalyst 6000 FlexWAN module from the chassis before removing a port adapter from the Catalyst 6000 FlexWAN module.

### Step 1

To remove the port adapter, remove the screw that secures the port adapter (or blank port adapter). (See A.)

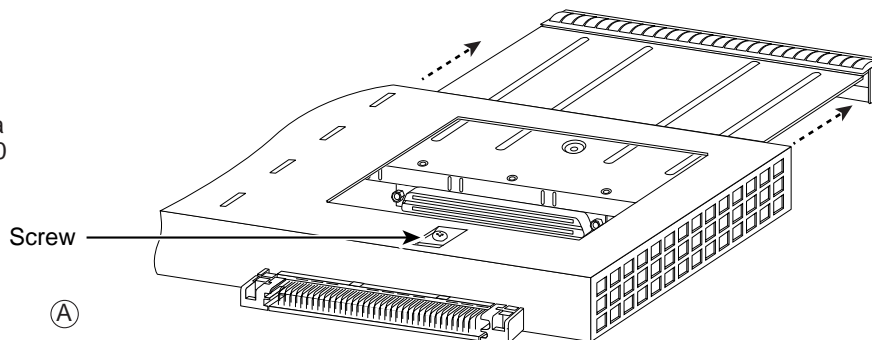

### Step 2

With the screw removed, grasp the handle on the front of the port adapter (or blank port adapter) and carefully pull it out of its bay, away from the edge connector at the rear of the bay. (See A.)

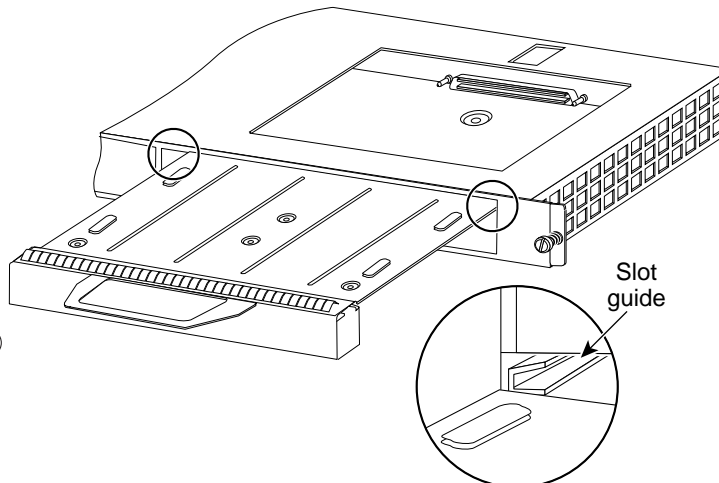

### Step 3

To install the port adapter, carefully align the port adapter carrier between the upper and the lower edges of the port adapter bay. (See B.)

### Step 4

Carefully slide the new port adapter into the port adapter bay until the connector on the port adapter is completely seated in the connector at the rear of the port adapter slot. (See B.)

### Step 5

Install the screw in the rear of the port adapter bay. Do not overtighten the screw. (See A.)

### Step 6

Reinstall the Catalyst 6000 FlexWAN module in the chassis, and tighten the captive installation screw on each side of the Catalyst 6000 FlexWAN module faceplate. (See C.)

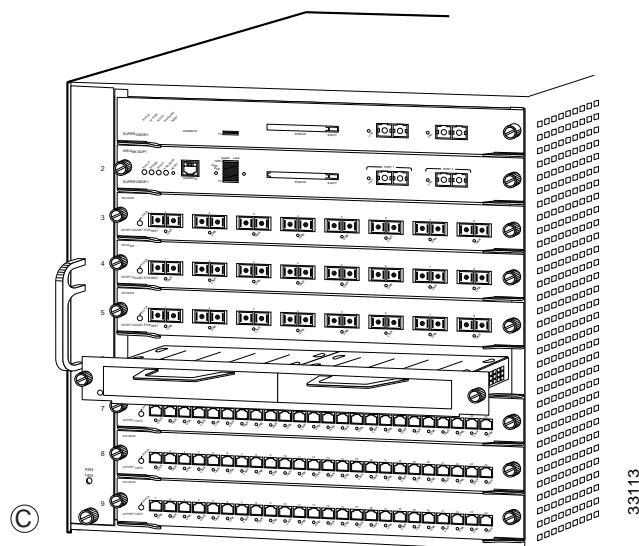

# Cisco 7100 Series Routers—Removing and Installing a Port Adapter

## Step 1

To remove the port adapter, use a number 2 Phillips screwdriver to loosen the screws on the locking tab. Then slide the tab down to the unlocked position.

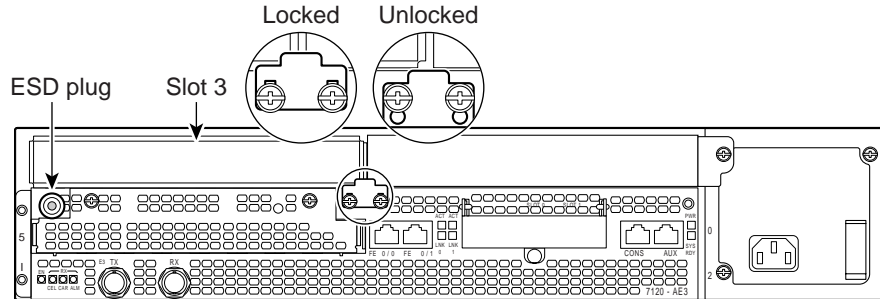

## Step 2

Grasp the handle of the port adapter and pull the port adapter from the router, about halfway out of its slot. If you are removing a blank port adapter, pull the blank port adapter completely out of the chassis slot.

## Step 3

With the port adapter halfway out of the slot, disconnect all cables from the port adapter.

## Step 4

After disconnecting the cables, pull the port adapter from its chassis slot.

## Step 5

To insert the port adapter, carefully align the port adapter carrier between the upper and the lower edges of the port adapter slot.

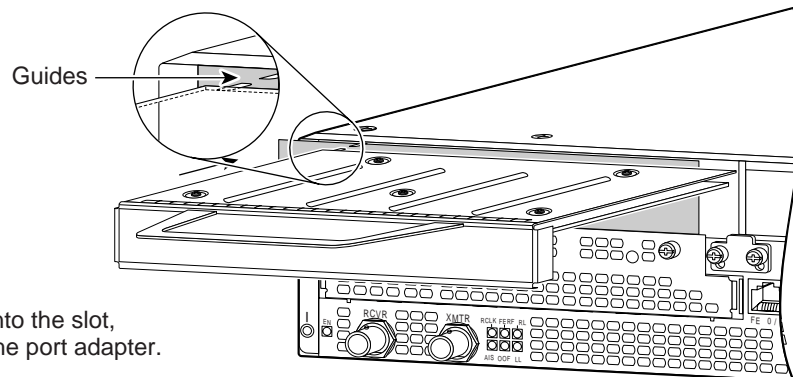

## Step 6

With the port adapter halfway into the slot, connect all required cables to the port adapter.

## Step 7

After connecting all required cables, carefully slide the port adapter all the way into the slot until the port adapter is seated in the router midplane.

## Step 8

After the port adapter is properly seated, lock the port adapter retaining mechanism.

26522

## Cisco 7200 Series Routers and Cisco 7200 VXR Routers—Removing and Installing a Port Adapter

### Step 1

To remove the port adapter, place the port adapter lever in the unlocked position. (See A.) The port adapter lever remains in the unlocked position.

### Step 2

Grasp the handle of the port adapter and pull the port adapter from the router, about halfway out of its slot. If you are removing a blank port adapter, pull the blank port adapter completely out of the chassis slot.

### Step 3

With the port adapter halfway out of the slot, disconnect all cables from the port adapter. After disconnecting the cables, pull the port adapter from its chassis slot.

### Step 4

To insert the port adapter, carefully align the port adapter carrier between the upper and the lower edges of the port adapter slot. (See B.)

### Step 5

Carefully slide the new port adapter halfway into the port adapter slot. (See B.)

### Step 6

With the port adapter halfway into the slot, connect all required cables to the port adapter. After connecting all required cables, carefully slide the port adapter all the way into the slot until the port adapter is seated in the router midplane.

### Step 7

After the port adapter is properly seated, lock the port adapter lever. (See A.)

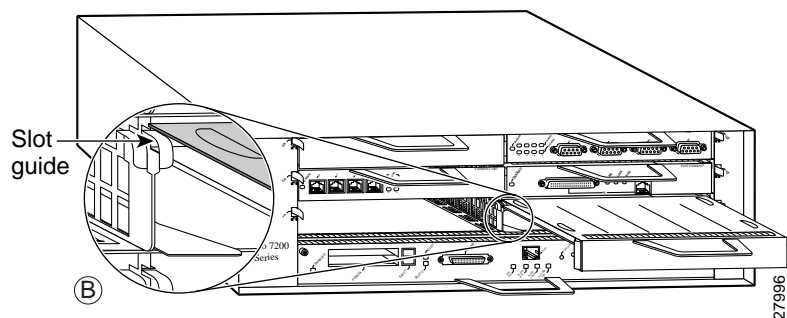
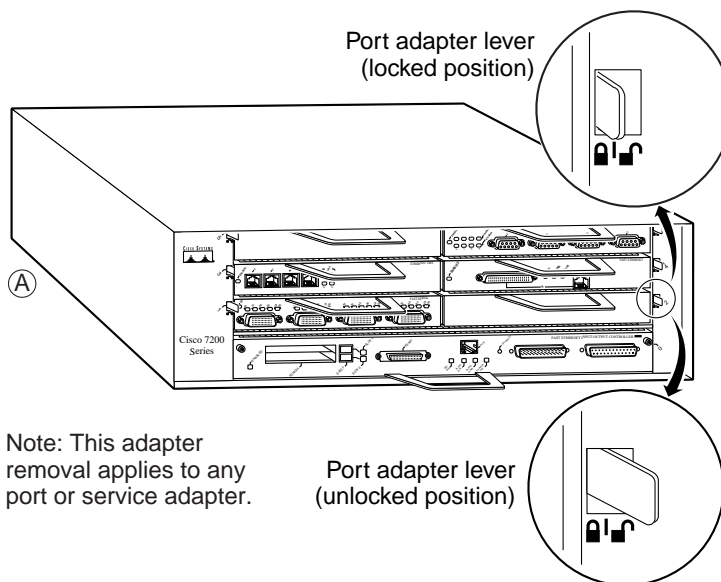

## Cisco uBR7200 Series Routers—Removing a Port Adapter

### Step 1

To remove the port adapter, unlock the port adapter retaining mechanism. The port adapter lever remains in the unlocked position.

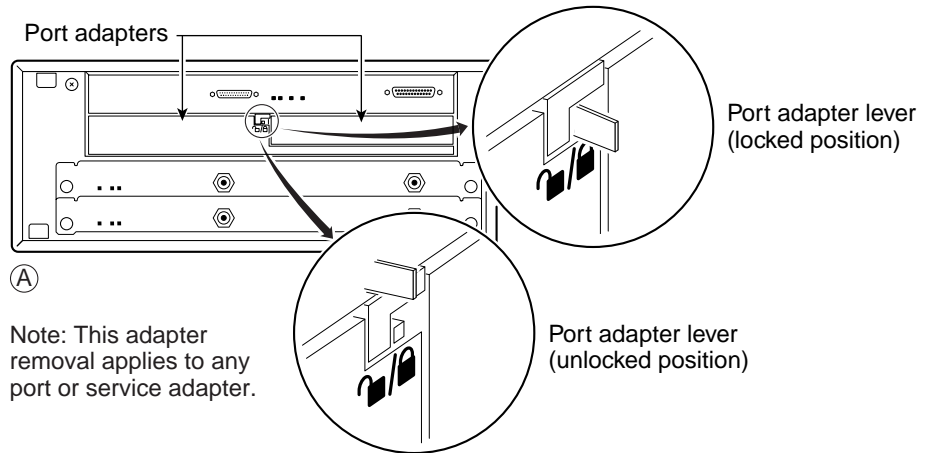

Place the port adapter lever (Cisco uBR7223, see A), or the port adapter retention clip (Cisco uBR7246 and Cisco uBR7246 VXR, see B) in the unlocked position. Either mechanism remains in the unlocked position.

### Step 2

Grasp the handle of the port adapter and pull the port adapter from the router, about halfway out of its slot. If you are removing a blank port adapter, pull the blank port adapter completely out of the chassis slot.

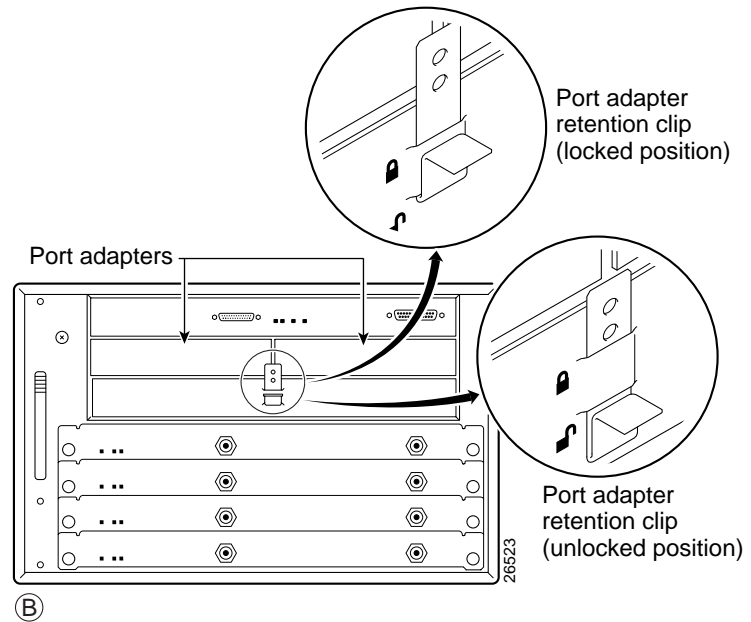

### Step 3

With the port adapter halfway out of the slot, disconnect all cables from the port adapter. After disconnecting the cables, pull the port adapter from its chassis slot.

## Cisco uBR7200 Series Routers—Installing a Port Adapter

### Step 1

To insert the port adapter, carefully align the port adapter carrier between the upper and the lower edges of the port adapter slot.

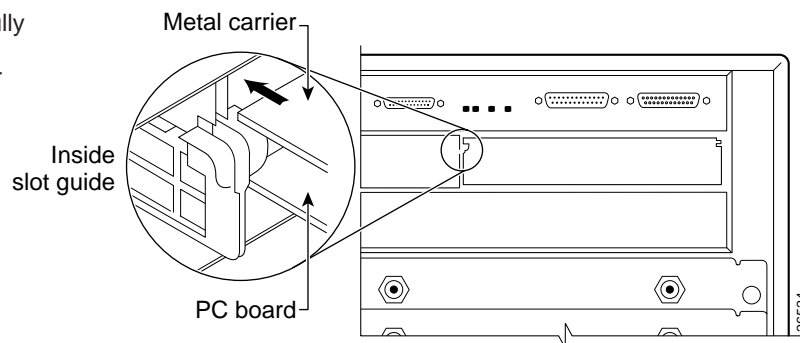

### Step 2

Carefully slide the new port adapter halfway into the port adapter slot.

### Step 3

With the port adapter halfway into the slot, connect all required cables to the port adapter. After connecting all required cables, carefully slide the port adapter all the way into the slot until the port adapter is seated in the router midplane.

### Step 4

After the port adapter is properly seated, lock the port adapter lever or retention clip, depending on your system. (See illustration on preceding page.)

## Cisco 7201 Router—Removing and Installing a Port Adapter

### Step 1

Use an ESD wrist strap to ground yourself to the router.

### Step 2

To remove the port adapter, place the port adapter lever in the unlocked position. The port adapter lever remains in the unlocked position.

### Step 3

Grasp the handle of the port adapter and pull the port adapter about halfway out of its slot. If you are removing a blank port adapter, pull the blank port adapter completely out of the chassis slot.

### Step 4

With the port adapter halfway out of the slot, disconnect all cables from the port adapter. After disconnecting the cables, pull the port adapter from the chassis slot.

### Caution

The port adapter must slide into the slot guides close to the chassis lid. Do not allow the port adapter components to come in contact with the system board or the port adapter could be damaged.

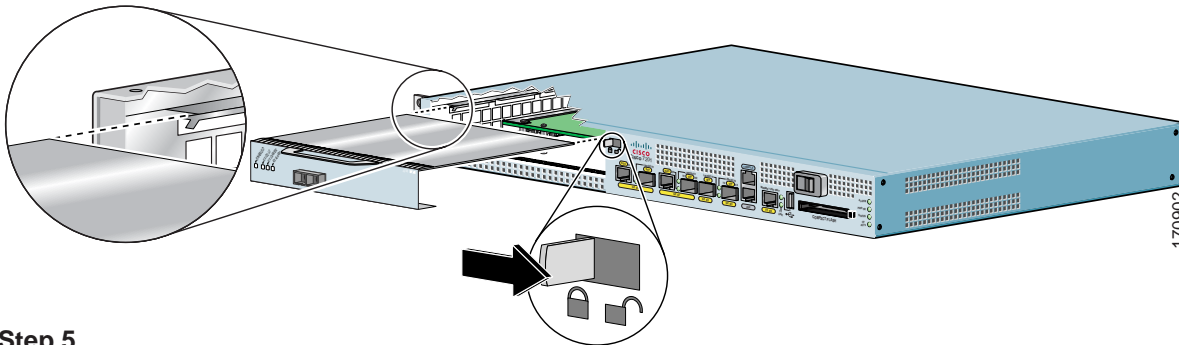

### Step 5

To insert the port adapter, carefully align the port adapter carrier in the slot guides. Slide the new port adapter halfway into the chassis.

### Step 6

Connect all the required cables to the port adapter. After connecting all required cables, carefully slide the port adapter all the way into the slot until the port adapter is seated in the midplane.

### Step 7

After the port adapter is properly seated, lock the port adapter lever.

## Cisco 7301 Router—Removing and Installing a Port Adapter

### Step 1

Use an ESD wrist strap to ground yourself to the router.

### Step 2

To remove a port adapter, use a Phillips screwdriver to turn the screw holding the port adapter latch. The screw should be loose enough to allow the latch to rotate to an unlocked position. (See A.) The latch can rotate 360°.

### Step 3

Grasp the handle and pull the port adapter from the router, about halfway out of its slot. (See B.) If you are removing a blank port adapter, pull the blank port adapter completely out of the chassis slot.

### Step 4

With the port adapter halfway out of the slot, disconnect all cables from the port adapter. After disconnecting the cables, pull the port adapter from its chassis slot.

### Caution

The port adapter must slide into the slot guides close to the chassis lid. (See C.) Do not allow the port adapter components to come in contact with the system board or the port adapter could be damaged.

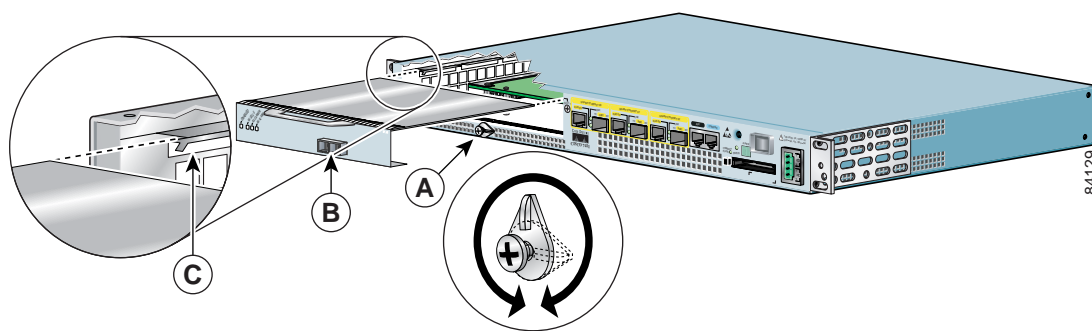

### Step 5

To insert the port adapter, carefully align the port adapter carrier in the slot guides. (See C.) Slide the new port adapter halfway into the chassis.

### Step 6

Connect all required cables to the port adapter. After connecting all required cables, carefully slide the port adapter all the way into the slot until the port adapter is seated in the midplane.

### Step 7

After the port adapter is properly seated, turn and secure the port adapter latch in the upright, locked position. (See A.) Tighten the screw to ensure the port adapter remains firmly in place.



## Cisco 7304 PCI Port Adapter Carrier Card—Removing and Installing a Port Adapter

You can install one single-width port adapter in a Cisco 7304 PCI Port Adapter Carrier Card. This section provides step-by-step instructions for removing and installing a port adapter in a Cisco 7304 PCI Port Adapter Carrier Card.



### Warning

When performing the following procedures, wear a grounding wrist strap to avoid ESD damage to the Cisco 7304 PCI Port Adapter Carrier Card. Some platforms have an ESD connector for attaching the wrist strap. Do not directly touch the midplane or backplane with your hand or any metal tool, or you could shock yourself.

To remove and install a port adapter in a Cisco 7304 PCI Port Adapter Carrier Card, refer to [Figure 3-2](#) and do the following:

- Step 1** If the Cisco 7304 PCI Port Adapter Carrier Card is still in the router, you must remove the Cisco 7304 PCI Port Adapter Carrier Card before removing a port adapter.
- Step 2** To remove the port adapter from the Cisco 7304 PCI Port Adapter Carrier Card, turn the port adapter lock from its locked and horizontal position shown in A of [Figure 3-2](#) to its unlocked and vertical position shown in B of [Figure 3-2](#).
- Step 3** Grasp the handle of the port adapter and pull the port adapter from the Cisco 7304 PCI Port Adapter Carrier Card. (You have already disconnected the cables from the port adapter when removing the Cisco 7304 PCI Port Adapter Carrier Card).
- Step 4** To insert the port adapter in the Cisco 7304 PCI Port Adapter Carrier Card, locate the guide rails inside the Cisco 7304 PCI Port Adapter Carrier Card that hold the port adapter in place. They are at the top left and top right of the port adapter slot and are recessed about an inch, as shown in C of [Figure 3-2](#).
- Step 5** Carefully slide the port adapter in the Cisco 7304 PCI Port Adapter Carrier Card until the port adapter makes contact with the port adapter interface connector. When fully seated, the port adapter front panel should be flush with the face of the Cisco 7304 PCI Port Adapter Carrier Card.
- Step 6** After the port adapter is properly seated, turn the port adapter lock to its locked and horizontal position, as shown in A of [Figure 3-2](#).

Figure 3-2 illustrates how to remove and install a port adapter in a Cisco 7304 PCI Port Adapter Carrier Card.

Figure 3-2 Cisco 7304 PCI Port Adapter Carrier Card—Port Adapter Removal and Installation

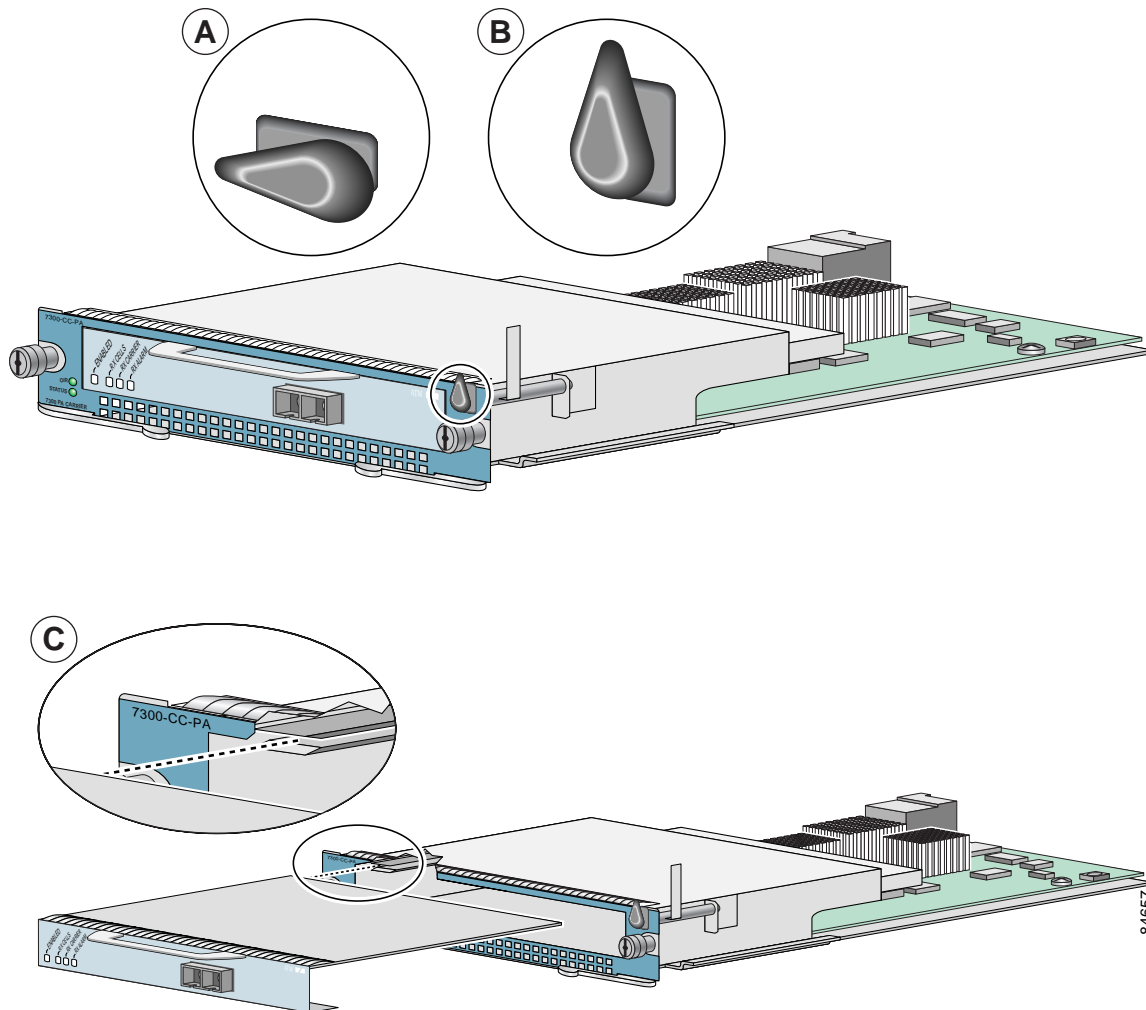

## Cisco 7401ASR Router—Removing and Installing a Port Adapter

### Step 1

To remove the port adapter, use a number 2 Phillips screwdriver to loosen the screw on the port adapter latch. Rotate the port adapter latch until it clears the faceplate of the port adapter. (See A.) The latch can rotate 360°.

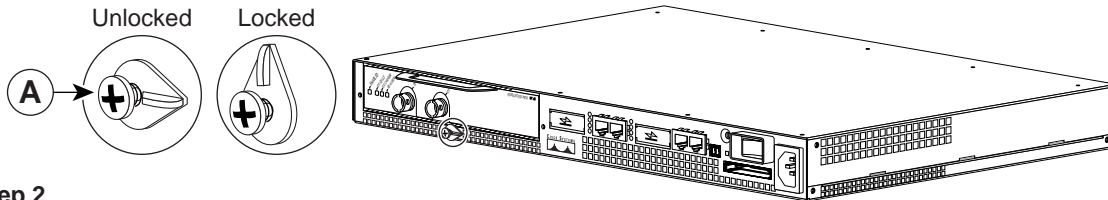

### Step 2

Pull the port adapter from the router, about halfway out of its slot. (If you remove a blank port adapter, keep the blank port adapter for use in the router if you should ever remove the port adapter. The port adapter slot must always be filled.)

### Step 3

With the port adapter halfway out of the slot, disconnect all cables from the port adapter. After disconnecting the cables, pull the port adapter completely out of the chassis slot.

### Step 4

To insert the port adapter, locate the port adapter slot guides inside the Cisco 7401ASR router. They are near the top, and are recessed about 1/2 inch. (See B.)

### Caution

The port adapter must slide into the slot guides under the chassis lid. Do not allow the port adapter components to come in contact with the system board, or the port adapter could be damaged.

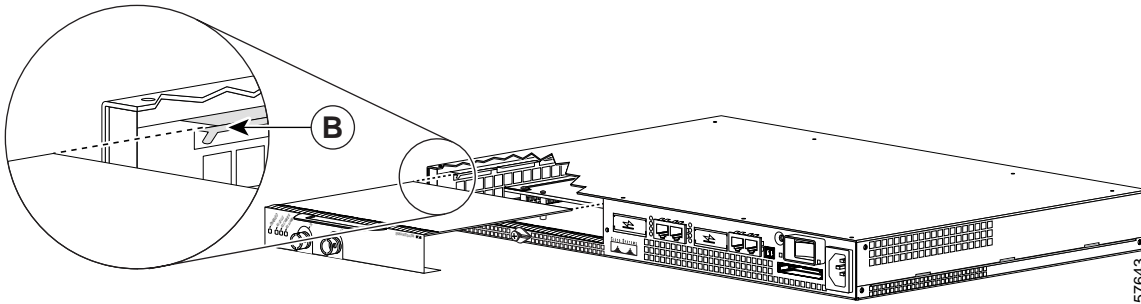

### Step 5

Insert the port adapter in the slot guides halfway, and then reconnect the port adapter cables.

### Step 6

After the cables are connected, carefully slide the port adapter all the way into the slot until the port adapter is seated in the router midplane. When installed, the port adapter input/output panel should be flush with the face of the router.

### Step 7

After the port adapter is properly seated, rotate the port adapter latch to the upright locked position and use a number 2 Phillips screwdriver to tighten the latch screw. If needed, loosen the latch screw to rotate the latch over the port adapter. Finish the installation by tightening the latch screw.

## VIP—Removing and Installing a Port Adapter

Note: You must first remove the VIP from the chassis before removing a port adapter from the VIP.

### Step 1

To remove the port adapter, remove the screw that secures the port adapter (or blank port adapter). (See A.)

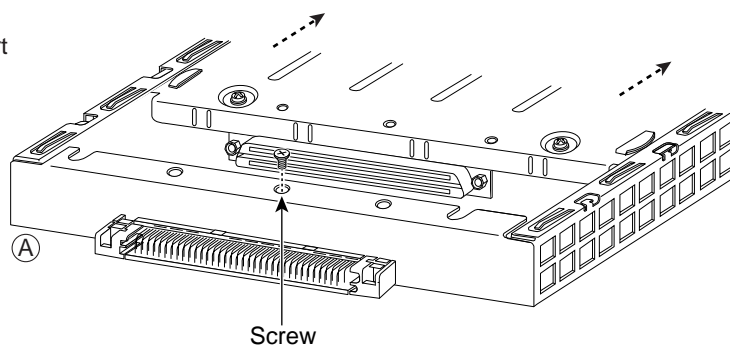

### Step 2

With the screw removed, grasp the handle on the front of the port adapter (or blank port adapter) and carefully pull it out of its slot, away from the edge connector at the rear of the slot. (See A.)

### Step 3

To insert the port adapter, carefully align the port adapter carrier between the upper and the lower edges of the port adapter slot. (See B.)

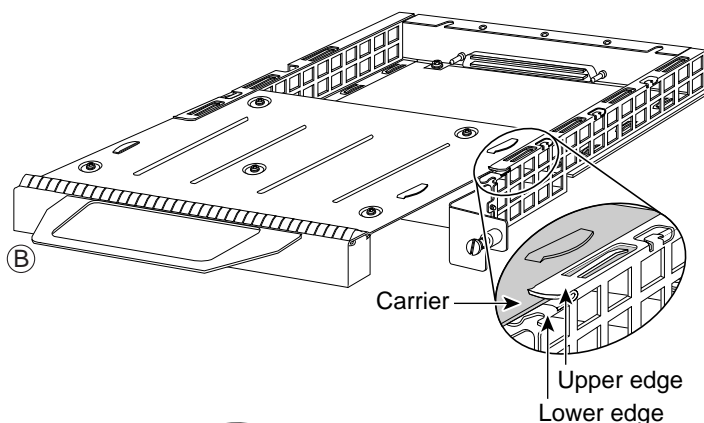

### Step 4

Carefully slide the new port adapter into the port adapter slot until the connector on the port adapter is completely seated in the connector at the rear of the port adapter slot. (See B.)

### Step 5

Install the screw in the rear of the port adapter slot on the VIP. Do not overtighten the screw. (See A.)

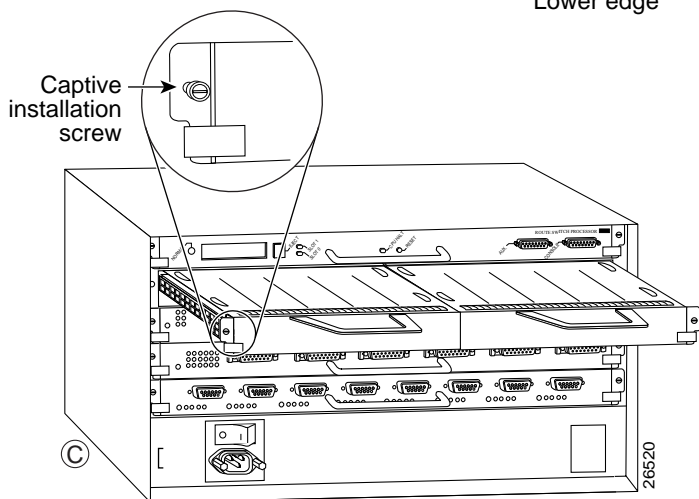

### Step 6

Carefully slide the VIP motherboard into the interface processor slot until the connectors at the rear of the VIP are completely seated in the connectors at the rear of the interface processor slot. Use the ejector levers to seat the VIP in the interface processor slot. Tighten the captive installation screws on the VIP. (See C.)



# CHAPTER 4

## Attaching the PA-4T+ Interface Cables

To continue your PA-4T+ port adapter installation, you must install the port adapter cables and configure the PA-4T+ interfaces. The instructions that follow apply to all supported platforms.

This chapter contains the following sections:

- [Connecting PA-4T+ Port Adapter Interface Cables, page 4-1](#)
- [Determining the Port Mode, page 4-2](#)

## Connecting PA-4T+ Port Adapter Interface Cables

On a single PA-4T+, you can use up to four synchronous serial connections. Use the following procedure to connect a serial cable to the PA-4T+:

- Step 1** Attach the appropriate serial cable directly to the receptacle on the PA-4T+ and tighten the strain-relief screws (see [Figure 4-1](#)).



**Note** Port adapters have a handle attached, but this handle is not shown to allow a detailed view of each port adapter's faceplate.

**Figure 4-1** Connecting PA-4T+ Serial Cables—Horizontal Orientation (Shown Without Handles)

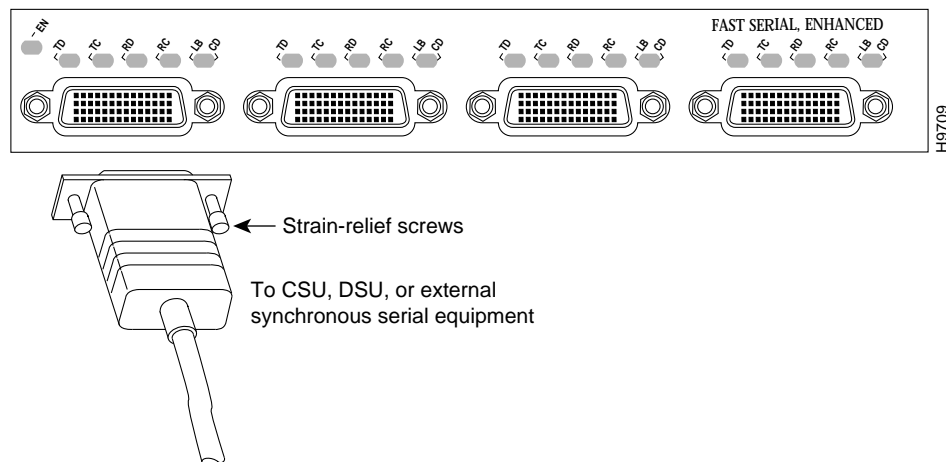

**Caution**

Serial interface cables must be attached correctly or damage to the cable plug will result. Attempting to force a cable plug on the 60-pin receptacle can damage the plug. (See [Figure 4-2](#).)

**Figure 4-2** Connecting Serial Port Adapter Cables

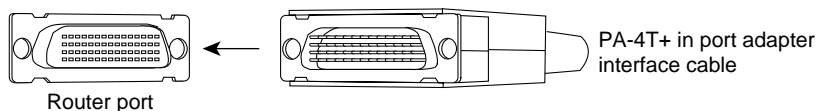
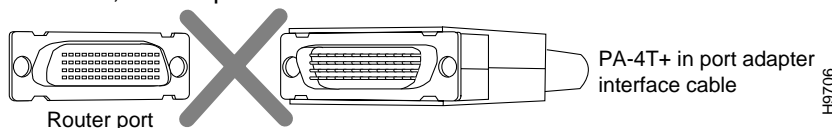
**Correct****Incorrect, cable upside down**

- Step 2** Attach the network end of the serial cable to your DSU, CSU, DTE, or other external synchronous serial equipment and tighten the strain-relief screws.

This completes the procedure for attaching serial interface cables to the PA-4T+.

## Determining the Port Mode

The port adapter cable connected to each port determines the electrical interface type and mode of the port. The default mode of the ports is DCE, which allows you to perform a loopback test on any port without having to attach a port adapter cable. Although DCE is the default, there is no default clock rate set on the interfaces. When there is no cable attached to a port, the software actually identifies the port as *Universal (cable unattached)* rather than either a DTE or DCE interface.

Following is an example of the **show controllers** command for Cisco 7100 series routers, Cisco 7200 series routers, Cisco uBR7200 series routers, Cisco 7201 routers, Cisco 7301 routers, or Cisco 7401ASR routers that shows an interface port (1/0) that has an EIA/TIA-232 DCE cable attached:

```
Router# show controllers serial 1/0

M4T: show controller:
PAS unit 8, subunit 0, f/w version 1-25, rev ID 0x2800001, version 2
idb = 0x60B83B40, ds = 0x60B858B8, ssb=0x60B85FFC
Clock mux=0x0, ucmd_ctrl=0x1C, port_status=0x3E
Serial config=0x0, line config=0x200
maxdgram=1524, bufpool=48Kb, 96 particles
    DCD=up DSR=up DTR=up RTS=up CTS=up
line state: up
cable type : V.24 (RS-232) DCE cable, received clockrate 9600
[display text omitted]
```

**Note**

In the above output from the **show controllers** command, the PA-4T+ is displayed as M4T.

Following is an example of the **show controllers cbus** command for a VIP that shows an interface port (3/1/0) that has an EIA/TIA-232 DTE cable attached:

```
Router# show controllers cbus 3/1/0

slot3: VIP2, hw 2.3, sw 21.40, ccb 5800FF30, cmdq 48000088, vps 8192
  software loaded from system
  IOS (tm) VIP Software (SVIP-DW-M), Version 11.1(8)CA, RELEASED SOFTWARE
  ROM Monitor version 17.0
  Mx Serial(4), HW Revision 0x2, FW Revision 1.25
  Serial3/1/0, applique is RS-232 DTE
    gfreeq 48000140, lfreeq 480001D0 (1536 bytes), throttled 0
    rxlo 4, rxhi 81, rxcurr 1, maxrxcurr 2
    txq 48001A00, txacc 48001A02 (value 6), txlimit 6
```

Following is an example of the **show controllers cbus** command for a Catalyst RSM/VIP2 that shows an interface port (1/0) that has an EIA/TIA-232 DTE cable attached:

```
Router# show controllers cbus 1/0

slot1: VIP2, hw 2.3, sw 21.40, ccb 5800FF30, cmdq 48000088, vps 8192
  software loaded from system
  IOS (tm) VIP Software (SVIP-DW-M), Version 11.1(8)CA, RELEASED SOFTWARE
  ROM Monitor version 17.0
  Mx Serial(4), HW Revision 0x2, FW Revision 1.25
  Serial3/1/0, applique is RS-232 DTE
    gfreeq 48000140, lfreeq 480001D0 (1536 bytes), throttled 0
    rxlo 4, rxhi 81, rxcurr 1, maxrxcurr 2
    txq 48001A00, txacc 48001A02 (value 6), txlimit 6
```



#### Note

The slot values displayed by some commands (such as **show diag** and **show controllers cbus**) are not relevant to any physical connection; disregard these slot values for the Catalyst RSM/VIP2.

To change the mode of a port online, use software commands to shut down the interface, replace the compact serial cable, restart the interface and, if necessary, reconfigure the port for the new interface. At system startup or restart, the system polls the interfaces and determines the electrical interface type of each port (according to the type of compact serial cable attached). However, the system does not necessarily repoll an interface when you change the adapter cable online. To ensure that the system recognizes the new interface type, shut down and reenables the interface after changing the cable.

If you are replacing a cable with a cable that has the same mode, these steps are not necessary (simply replace the cable without interrupting operation).

- Step 1** Enter configuration mode and at the privileged level of the EXEC (also called enable mode), specify the port address, shut down the interface, and write the configuration to nonvolatile random-access memory (NVRAM). (See the [“Using the EXEC Command Interpreter”](#) section on page 5-1 for an explanation of the privileged level of the EXEC.) Add additional configuration commands, as needed, before you exit from configuration mode (before you press **Ctrl-Z** or enter **end**).

For the Cisco 7100 series routers, Cisco 7200 series routers, Cisco uBR7200 series routers, Cisco 7201 router, Cisco 7301 router, or Cisco 7401ASR router use the following commands:

```
Router> enable
Password:
Router# configure terminal
Enter configuration commands, one per line. End with CNTL/Z.
Router(config)# interface serial 1/0
Router(config-if)# shutdown
Ctrl-Z
Router#
```

For a VIP, use the following commands:

```
Router> enable
Password:
Router# configure terminal
Enter configuration commands, one per line. End with CNTL/Z.
Router(config)# interface serial 3/1/0
Router(config-if)# shutdown
Ctrl-Z
Router#
```

For a Catalyst 6000 family FlexWAN module, use the following commands:

```
Router# configure terminal
Enter configuration commands, one per line. End with CNTL/Z.
Router(config)#
Router(config)# interface serial 3/0/0
Router(config-if)# shutdown
Ctrl-Z
Router#
```

For a Catalyst RSM/VIP2, use the following commands:

```
Router> enable
Password:
Router# configure terminal
Enter configuration commands, one per line. End with CNTL/Z.
Router(config)# interface serial 1/0
Router(config-if)# shutdown
Ctrl-Z
Router#
```

- Step 2 Locate and remove the adapter cable to be replaced.
- Step 3 Connect the new cable between the PA-4T+ and the network connection. Tighten the thumbscrews at both ends of the cable to secure it in the ports.
- Step 4 Enter configuration mode again, bring the port back up, and save the running configuration to NVRAM.

For the Cisco 7100 series routers, Cisco 7200 series routers, Cisco uBR7200 series routers, Cisco 7201 router, Cisco 7301 router, or Cisco 7401ASR router use the following commands:

```
Router# configure terminal
Enter configuration commands, one per line. End with CNTL/Z.
Router(config)# interface serial 1/0
Router(config-if)# no shutdown
Ctrl-Z
Router#
```

```
Router# copy running-config startup-config
```

For a VIP, use the following commands:

```
Router# configure terminal
Enter configuration commands, one per line. End with CNTL/Z.
Router(config)# interface serial 3/1/0
Router(config-if)# no shutdown
Ctrl-Z
Router#
```

```
Router# copy running-config startup-config
```



For a Catalyst 6000 family FlexWAN module, use the following commands:

```
Router# configure terminal
Enter configuration commands, one per line. End with CNTL/Z.
Router(config)# interface serial 3/0/0
Router(config-if)# no shutdown
Ctrl-Z
Router#

Router# copy running-config startup-config
```

For a Catalyst RSM/VIP2, use the following commands:

```
Router# configure terminal
Enter configuration commands, one per line. End with CNTL/Z.
Router(config)# interface serial 1/0
Router(config-if)# no shutdown
Ctrl-Z
Router#

Router# copy running-config startup-config
```

These steps will prompt the system to poll the interface and recognize the new interface immediately.

When you configure a port for a DCE interface for the first time, or when you set up a loopback test, you must set the clock rate for the port. When you connect a DCE cable to a port, the interface will remain down, the clock LEDs will remain off, and the interface will not function until you set a clock rate (regardless of the DCE mode default).

If you are changing the mode of the interface from DCE to DTE, you do not need to change the clock rate for the port. After you replace the DCE cable with a DTE cable and the system recognizes the interface as a DTE, it will use the external clock signal from the remote DCE device and ignore the internal clock signal that the DCE interface normally uses. Therefore, after you configure the clock rate on a port for either a DCE interface or loopback, you can leave the clock rate configured and still use that port as a DTE interface.

---

This completes the procedure for replacing a port adapter cable on the PA-4T+. Proceed to [Chapter 5, “Configuring the PA-4T+ Interfaces,”](#) to configure the interfaces on your PA-4T+.





# CHAPTER 5

## Configuring the PA-4T+ Interfaces

---

To continue your PA-4T+ port adapter installation, you must configure the serial interfaces. The instructions that follow apply to all supported platforms. Minor differences between the platforms are noted.

This chapter contains the following sections:

- [Using the EXEC Command Interpreter, page 5-1](#)
- [Configuring the Interfaces, page 5-2](#)
- [Configuring Half-Duplex and Binary Synchronous Communications in Cisco 7200 Series Routers, page 5-16](#)
- [Checking the Configuration, page 5-18](#)

### Using the EXEC Command Interpreter

You modify the configuration of your router through the software command interpreter called the EXEC (also called enable mode). You must enter the privileged level of the EXEC command interpreter with the **enable** command before you can use the **configure** command to configure a new interface or to change the existing configuration of an interface. The system prompts you for a password if one is set.

The system prompt for the privileged level ends with a pound sign (#) instead of an angle bracket (>). At the console terminal, use the following procedure to enter the privileged level:

- 
- Step 1** At the user-level EXEC prompt, enter the **enable** command. The EXEC prompts you for a privileged-level password as follows:

```
Router> enable
```

```
Password:
```

- Step 2** Enter the password (the password is case-sensitive). For security purposes, the password is not displayed.

When you enter the correct password, the system displays the privileged-level system prompt (#):

```
Router#
```

---

# Configuring the Interfaces

After you verify that the new PA-4T+ is installed correctly (the enabled LED goes on), use the privileged-level **configure** command to configure the new interfaces. Be prepared with the information you will need, such as the following:

- Protocols you plan to route on each new interface
- IP addresses if you will configure the interfaces for IP routing
- Whether or not the new interfaces will use bridging
- Timing source for each new interface and clock speeds for external timing

If you installed a new PA-4T+ or if you want to change the configuration of an existing interface, you must enter configuration mode using the **configure** command. If you replaced a PA-4T+ that was previously configured, the system will recognize the new PA-4T+ interfaces and bring each of them up in their existing configurations.

For a summary of the configuration options available and instructions for configuring interfaces on the PA-4T+, refer to the appropriate configuration publications listed in the [“Related Documentation” section on page viii](#).

You execute configuration commands from the privileged level of the EXEC command interpreter, which usually requires password access. Contact your system administrator, if necessary, to obtain password access. (See the [“Using the EXEC Command Interpreter” section on page 5-1](#) for an explanation of the privileged level of the EXEC.)

This section contains the following subsections:

- [Shutting Down an Interface, page 5-2](#)
- [Performing a Basic Configuration, page 5-8](#)
- [Configuring Timing \(Clock\) Signals, page 5-11](#)
- [Configuring NRZI Format, page 5-14](#)
- [Configuring Cyclic Redundancy Checks, page 5-15](#)

## Shutting Down an Interface

Before you remove an interface that you will not replace, replace a compact serial cable, or replace port adapters, use the **shutdown** command to shut down (disable) the interfaces to prevent anomalies when you reinstall the new or reconfigured interface processor. When you shut down an interface, it is designated administratively down in the **show** command displays.

Follow these steps to shut down an interface:

- 
- Step 1** Enter the privileged level of the EXEC command interpreter. (See the [“Using the EXEC Command Interpreter” section on page 5-1](#) for instructions.)
  - Step 2** At the privileged-level prompt, enter configuration mode and specify that the console terminal will be the source of the configuration subcommands as follows:  

```
Router# configure terminal  
Enter configuration commands, one per line. End with CNTL/Z.  
Router(config)#
```
  - Step 3** Shut down interfaces by entering the **interface serial** subcommand (followed by the interface address of the interface), and then enter the **shutdown** command.

When you have finished, press **Ctrl-Z**—hold down the **Control** key while you press **Z**—or enter **end** or **exit** to exit configuration mode and return to the EXEC command interpreter

Table 5-1 shows the **shutdown** command syntax for the supported platforms.

**Table 5-1** Syntax of the **shutdown** Command for the Supported Platforms

Platform	Command	Example
Catalyst RSM/VIP2 in Catalyst 5000 family switches	<b>interface</b> , followed by the <i>type (serial)</i> and <i>slot/port</i> (port-adapter-slot-number/interface-port-number)  <b>shutdown</b>	The example is for interface 0 and interface 1 on a port adapter in port adapter slot 1.  Router(config-if)# <b>interface serial 1/0</b> Router(config-if)# <b>shutdown</b> Router(config-if)# <b>interface serial 1/1</b> Router(config-if)# <b>shutdown</b> <b>Ctrl-Z</b> Router#
Catalyst 6000 family FlexWAN module in Catalyst 6000 family switches	<b>interface</b> , followed by the <i>type (serial)</i> and <i>mod_num/bay/port</i> (module-slot-number/port-adapter-bay-number/interface-port-number)  <b>shutdown</b>	The example is for interface 0 and interface 1 on a port adapter in port adapter bay 0 of a FlexWAN module installed in module slot 3.  Router(config-if)# <b>interface serial 3/0/0</b> Router(config-if)# <b>shutdown</b> Router(config-if)# <b>interface serial 3/0/1</b> Router(config-if)# <b>shutdown</b> <b>Ctrl-Z</b> Router#
Cisco 7120 series routers	<b>interface</b> , followed by the <i>type (serial)</i> and <i>slot/port</i> (port-adapter-slot-number/interface-port-number)  <b>shutdown</b>	The example is for interface 0 and interface 1 on a port adapter in port adapter slot 3.  Router(config-if)# <b>interface serial 3/0</b> Router(config-if)# <b>shutdown</b> Router(config-if)# <b>interface serial 3/1</b> Router(config-if)# <b>shutdown</b> <b>Ctrl-Z</b> Router#
Cisco 7140 series routers	<b>interface</b> , followed by the <i>type (serial)</i> and <i>slot/port</i> (port-adapter-slot-number/interface-port-number)  <b>shutdown</b>	The example is for interface 0 and interface 1 on a port adapter in port adapter slot 4.  Router(config-if)# <b>interface serial 4/0</b> Router(config-if)# <b>shutdown</b> Router(config-if)# <b>interface serial 4/1</b> Router(config-if)# <b>shutdown</b> <b>Ctrl-Z</b> Router#
Cisco 7200 series routers and Cisco 7200 VXR routers	<b>interface</b> , followed by the <i>type (serial)</i> and <i>slot/port</i> (port-adapter-slot-number/interface-port-number)  <b>shutdown</b>	The example is for interface 0 and interface 1 on a port adapter in port adapter slot 6.  Router(config-if)# <b>interface serial 6/0</b> Router(config-if)# <b>shutdown</b> Router(config-if)# <b>interface serial 6/1</b> Router(config-if)# <b>shutdown</b> <b>Ctrl-Z</b> Router#

Table 5-1 Syntax of the shutdown Command for the Supported Platforms (continued)

Platform	Command	Example
Cisco 7201 router	<b>interface</b> , followed by the <i>type</i> ( <b>serial</b> ) and <i>slot/port</i> (port-adapter-slot-number/interface-port-number)  <b>shutdown</b>	The example is for interface 0 and interface 1 on a port adapter in port adapter slot 1.  Router(config-if)# <b>interface serial 1/0</b> Router(config-if)# <b>shutdown</b> Router(config-if)# <b>interface serial 1/1</b> Router(config-if)# <b>shutdown</b> <b>Ctrl-Z</b> Router#
Cisco uBR7223 router	<b>interface</b> , followed by the <i>type</i> ( <b>serial</b> ) and <i>slot/port</i> (port-adapter-slot-number/interface-port-number)  <b>shutdown</b>	The example is for interface 0 and interface 1 on a port adapter in port adapter slot 1.  Router(config-if)# <b>interface serial 1/0</b> Router(config-if)# <b>shutdown</b> Router(config-if)# <b>interface serial 1/1</b> Router(config-if)# <b>shutdown</b> <b>Ctrl-Z</b> Router#
Cisco uBR7246 router	<b>interface</b> , followed by the <i>type</i> ( <b>serial</b> ) and <i>slot/port</i> (port-adapter-slot-number/interface-port-number)  <b>shutdown</b>	The example is for interface 0 and interface 1 on a port adapter in port adapter slot 2.  Router(config-if)# <b>interface serial 2/0</b> Router(config-if)# <b>shutdown</b> Router(config-if)# <b>interface serial 2/1</b> Router(config-if)# <b>shutdown</b> <b>Ctrl-Z</b> Router#
Cisco 7301 router	<b>interface</b> , followed by the <i>type</i> ( <b>serial</b> ) and <i>slot/port</i> (port-adapter-slot-number/interface-port-number)  <b>shutdown</b>	The example is for interface 0 and interface 1 on a port adapter in port adapter slot 1.  Router(config-if)# <b>interface serial 1/0</b> Router(config-if)# <b>shutdown</b> Router(config-if)# <b>interface serial 1/1</b> Router(config-if)# <b>shutdown</b> <b>Ctrl-Z</b> Router#
Cisco 7304 PCI Port Adapter Carrier Card in a Cisco 7304 router	<b>interface</b> , followed by the <i>type</i> ( <b>serial</b> ) and <i>slot/port</i> (module-slot-number/interface-port-number)  <b>shutdown</b>	The example is for interface 0 and interface 1 on a port adapter in a Cisco 7304 PCI Port Adapter Carrier Card in module slot 3 of a Cisco 7304 router.  Router(config-if)# <b>interface serial 3/0</b> Router(config-if)# <b>shutdown</b> Router(config-if)# <b>interface serial 3/1</b> Router(config-if)# <b>shutdown</b> <b>Ctrl-Z</b> Router#

Table 5-1 Syntax of the shutdown Command for the Supported Platforms (continued)

Platform	Command	Example
Cisco 7401ASR router	<b>interface</b> , followed by the <i>type (serial)</i> and <i>slot/port</i> (port-adapter-slot-number/interface-port-number)  <b>shutdown</b>	The example is for interface 0 and interface 1 on a port adapter in port adapter slot 1.  Router(config-if)# <b>interface serial 1/0</b> Router(config-if)# <b>shutdown</b> Router(config-if)# <b>interface serial 1/1</b> Router(config-if)# <b>shutdown</b> <b>Ctrl-Z</b> Router#
VIP in Cisco 7000 series routers or Cisco 7500 series routers	<b>interface</b> , followed by the <i>type (serial)</i> and <i>slot/port adapter/port</i> (interface-processor-slot-number/port-adapter-slot-number/interface-port-number)  <b>shutdown</b>	The example is for interface 1 and interface 0 on a port adapter in port adapter slot 1 of a VIP installed in interface processor slot 1.  Router(config-if)# <b>interface serial 1/1/1</b> Router(config-if)# <b>shutdown</b> Router(config-if)# <b>interface serial 1/1/0</b> Router(config-if)# <b>shutdown</b> <b>Ctrl-Z</b> Router#

**Note**

If you need to shut down additional interfaces, enter the **interface serial** command (followed by the interface address of the interface) for each of the interfaces on your port adapter. Use the **no shutdown** command to enable the interface.

- Step 4** Write the new configuration to NVRAM as follows:

```
Router# copy running-config startup-config
[OK]
Router#
```

The system displays an OK message when the configuration has been stored.

- Step 5** Verify that new interfaces are now in the correct state (shut down) using the **show interfaces** command (followed by the interface type and interface address of the interface) to display the specific interface.

Table 5-2 provides examples of the **show interfaces serial** command for the supported platforms.

**Table 5-2** Examples of the **show interfaces serial** Command for the Supported Platforms

Platform	Command	Example
Catalyst RSM/VIP2 in Catalyst 5000 family switches	<b>show interfaces serial</b> , followed by <i>slot/port</i> (port-adapter-slot-number/interface-port-number)	The example is for interface 0 on a port adapter in port adapter slot 1. Router# <b>show interfaces serial 1/0</b>  Serial 1/0 is administratively down, line protocol is down  [Additional display text omitted from this example]
Catalyst 6000 family FlexWAN module in Catalyst 6000 family switches	<b>show interfaces serial</b> , followed by <i>mod_num/bay/port</i> (module-slot-number/port-adapter-bay-number/interface-port-number)	The example is for interface 0 on a port adapter in port adapter bay 0 of a FlexWAN module in module slot 3. Router# <b>show interfaces serial 3/0/0</b>  Serial 3/0/0 is administratively down, line protocol is down  [Additional display text omitted from this example]
Cisco 7120 series routers	<b>show interfaces serial</b> , followed by <i>slot/port</i> (port-adapter-slot-number/interface-port-number)	The example is for interface 0 on a port adapter in port adapter slot 3. Router# <b>show interfaces serial 3/0</b>  Serial 3/0 is administratively down, line protocol is down  [Additional display text omitted from this example]
Cisco 7140 series routers	<b>show interfaces serial</b> , followed by <i>slot/port</i> (port-adapter-slot-number/interface-port-number)	The example is for interface 0 on a port adapter in port adapter slot 4. Router# <b>show interfaces serial 4/0</b>  Serial 4/0 is administratively down, line protocol is down  [Additional display text omitted from this example]
Cisco 7200 series routers and Cisco 7200 VXR routers	<b>show interfaces serial</b> , followed by <i>slot/port</i> (port-adapter-slot-number/interface-port-number)	The example is for interface 0 on a port adapter in port adapter slot 6. Router# <b>show interfaces serial 6/0</b>  Serial 6/0 is administratively down, line protocol is down  [Additional display text omitted from this example]



Table 5-2 Examples of the `show interfaces serial` Command for the Supported Platforms (continued)

Platform	Command	Example
Cisco 7201 router	<b>show interfaces serial</b> , followed by <i>slot/port</i> (port-adapter-slot-number/interface-port-number)	The example is for interface 0 on a port adapter in port adapter slot 1. Router# <b>show interfaces serial 1/0</b>  Serial 1/0 is administratively down, line protocol is down  [Additional display text omitted from this example]
Cisco uBR7223 router	<b>show interfaces serial</b> , followed by <i>slot/port</i> (port-adapter-slot-number/interface-port-number)	The example is for interface 0 on a port adapter in port adapter slot 1. Router# <b>show interfaces serial 1/0</b>  Serial 1/0 is administratively down, line protocol is down  [Additional display text omitted from this example]
Cisco uBR7246 router	<b>show interfaces serial</b> , followed by <i>slot/port</i> (port-adapter-slot-number/interface-port-number)	The example is for interface 0 on a port adapter in port adapter slot 2. Router# <b>show interfaces serial 2/0</b>  Serial 2/0 is administratively down, line protocol is down  [Additional display text omitted from this example]
Cisco 7301 router	<b>show interfaces serial</b> , followed by <i>slot/port</i> (port-adapter-slot-number/interface-port-number)	The example is for interface 0 on a port adapter in port adapter slot 1. Router# <b>show interfaces serial 1/0</b>  Serial 1/0 is administratively down, line protocol is down  [Additional display text omitted from this example]
Cisco 7304 PCI Port Adapter Carrier Card in a Cisco 7304 router	<b>show interfaces serial</b> , followed by <i>slot/port</i> (module-slot-number/interface-port-number)	The example is for interface 0 on a port adapter in a Cisco 7304 PCI Port Adapter Carrier Card in module slot 3 of a Cisco 7304 router. Router# <b>show interfaces serial 3/0</b>  Serial 3/0 is administratively down, line protocol is down  [Additional display text omitted from this example]

Table 5-2 Examples of the `show interfaces serial` Command for the Supported Platforms (continued)

Platform	Command	Example
Cisco 7401ASR router	<b>show interfaces serial</b> , followed by <i>slot/port</i> (port-adapter-slot-number/interface-port-number)	The example is for interface 0 on a port adapter in port adapter slot 1. Router# <b>show interfaces serial 1/0</b>  Serial 1/0 is administratively down, line protocol is down  [Additional display text omitted from this example]
VIP in Cisco 7000 series routers or Cisco 7500 series routers	<b>show interfaces serial</b> , followed by <i>slot/port adapter/port</i> (interface-processor-slot-number/port-adapter-slot-number/interface-port-number)	The example is for interface 0 on a port adapter in port adapter slot 1 of a VIP in interface processor slot 1. Router# <b>show interfaces serial 1/1/0</b>  Serial 1/1/0 is administratively down, line protocol is down  [Additional display text omitted from this example]

- Step 6** Re-enable the interfaces by doing the following:
- Repeat Step 3 to re-enable an interface. Substitute the **no shutdown** command for the **shutdown** command.
  - Repeat Step 4 to write the new configuration to memory. Use the **copy running-config startup-config** command.
  - Repeat Step 5 to verify that the interfaces are in the correct state. Use the **show interfaces** command followed by the interface type and interface address of the interface.

For complete descriptions of software configuration commands, refer to the publications listed in the [“Related Documentation” section on page viii](#). Proceed to the following section to configure the new interfaces.

## Performing a Basic Configuration

Following are instructions for a basic interface configuration, which includes enabling an interface, specifying IP routing, and setting up external timing on a DCE interface. You might also need to enter other configuration subcommands, depending on the requirements for your system configuration and the protocols you plan to route on the interface. For complete descriptions of configuration subcommands and the configuration options available for serial interfaces, refer to the appropriate software documentation.

In the following procedure, press the **Return** key after each step unless otherwise noted. At any time you can exit the privileged level and return to the user level by entering **disable** at the prompt as follows:

```
Router# disable
```

```
Router>
```

- Step 1** At the privileged-level prompt, enter configuration mode and specify that the console terminal will be the source of the configuration subcommands as follows:

```
Router# configure terminal
Enter configuration commands, one per line. End with CNTL/Z.
Router(config)#
```

- Step 2** Specify the first interface to configure by entering the **interface serial** subcommand, followed by the interface address of the interface you plan to configure.

Table 5-3 provides examples of the **interface serial** subcommand for the supported platforms.

**Table 5-3** Examples of the interface serial Subcommand for the Supported Platforms

Platform	Command	Example
Catalyst RSM/VIP2 in Catalyst 5000 family switches	<b>interface serial</b> , followed by <i>slot/port</i> (port-adapter-slot-number/ interface-port-number)	The example is for interface 0 of a port adapter in port adapter slot 0.  Router(config)# <b>interface serial 0/0</b> Router(config-if)#
Catalyst 6000 family FlexWAN module in Catalyst 6000 family switches	<b>interface serial</b> , followed by <i>mod_num/bay/port</i> (module-slot-number/ port-adapter-bay-number/ interface-port-number)	The example is for interface 0 of a port adapter in port adapter bay 0 of a FlexWAN module in module slot 3.  Router(config)# <b>interface serial 3/0/0</b> Router(config-if)#
Cisco 7120 series routers	<b>interface serial</b> , followed by <i>slot/port</i> (port-adapter-slot-number/ interface-port-number)	The example is for interface 0 of a port adapter in port adapter slot 3.  Router(config)# <b>interface serial 3/0</b> Router(config-if)#
Cisco 7140 series routers	<b>interface serial</b> , followed by <i>slot/port</i> (port-adapter-slot-number/ interface-port-number)	The example is for interface 0 of a port adapter in port adapter slot 4.  Router(config)# <b>interface serial 4/0</b> Router(config-if)#
Cisco 7200 series routers and Cisco 7200 VXR routers	<b>interface serial</b> , followed by <i>slot/port</i> (port-adapter-slot-number/ interface-port-number)	The example is for interface 0 of a port adapter in port adapter slot 6.  Router(config)# <b>interface serial 6/0</b> Router(config-if)#
Cisco 7201 router	<b>interface serial</b> , followed by <i>slot/port</i> (port-adapter-slot-number/ interface-port-number)	The example is for interface 0 of a port adapter in port adapter slot 1.  Router(config)# <b>interface serial 1/0</b> Router(config-if)#
Cisco uBR7223 router	<b>interface serial</b> , followed by <i>slot/port</i> (port-adapter-slot-number/ interface-port-number)	The example is for interface 0 of a port adapter in port adapter slot 1.  Router(config)# <b>interface serial 1/0</b> Router(config-if)#
Cisco uBR7246 router	<b>interface serial</b> , followed by <i>slot/port</i> (port-adapter-slot-number/ interface-port-number)	The example is for interface 0 of a port adapter in port adapter slot 2.  Router(config)# <b>interface serial 2/0</b> Router(config-if)#

Table 5-3 Examples of the interface serial Subcommand for the Supported Platforms (continued)

Platform	Command	Example
Cisco 7301 router	<b>interface serial</b> , followed by <i>slot/port</i> (port-adapter-slot-number/ interface-port-number)	The example is for interface 0 of a port adapter in port adapter slot 1.  Router(config)# <b>interface serial 1/0</b> Router(config-if)#
Cisco 7304 PCI Port Adapter Carrier Card in a Cisco 7304 router	<b>interface serial</b> , followed by <i>slot/port</i> (module-slot-number/ interface-port-number)	The example is for interface 0 on a port adapter in a Cisco 7304 PCI Port Adapter Carrier Card in module slot 3 of a Cisco 7304 router.  Router(config)# <b>interface serial 3/0</b> Router(config-if)#
Cisco 7401ASR router	<b>interface serial</b> , followed by <i>slot/port</i> (port-adapter-slot-number/ interface-port-number)	The example is for interface 0 of a port adapter in port adapter slot 1.  Router(config)# <b>interface serial 1/0</b> Router(config-if)#
VIP in Cisco 7000 series or Cisco 7500 series routers	<b>interface serial</b> , followed by <i>slot/port adapter/port</i> (interface-processor-slot-number/ port-adapter-slot-number/ interface-port-number)	The example is for interface 0 of a port adapter in port adapter slot 1 of a VIP in interface processor slot 1.  Router(config)# <b>interface serial 1/1/0</b> Router(config-if)#

- Step 3** Assign an IP address and subnet mask to the interface (if IP routing is enabled on the system) by using the **ip address** configuration subcommand, as in the following example:

```
Router(config-if)# ip address 10.10.10.10 255.255.255.255
```

- Step 4** Add any additional configuration subcommands required to enable routing protocols and set the interface characteristics.



**Note** If you are configuring a DTE interface, proceed to Step 6. If you are configuring a DCE interface, you need to configure the external clock signal, as described in the next step.

The example in Step 5 applies to all systems in which the PA-4T+ is supported.

- Step 5** Set the clock rate with the **clock rate** command. (See the “[Configuring Timing \(Clock\) Signals](#)” section on page 5-11.)

```
Router(config-if)# clock rate 64000
```

- Step 6** Re-enable the interfaces using the **no shutdown** command. (See the “[Shutting Down an Interface](#)” section on page 5-2.)

- Step 7** Configure all additional port adapter interfaces as required.

- Step 8** When you have included all of the configuration subcommands to complete the configuration, press **Ctrl-Z** (hold down the **Control** key while you press **Z**) or enter **end** to exit configuration mode and return to the EXEC command interpreter prompt.

**Step 9** Write the new configuration to NVRAM as follows:

```
Router# copy running-config startup-config
[OK]
Router#
```

---

This completes the procedure for creating a basic configuration.

## Configuring Timing (Clock) Signals

All PA-4T+ interfaces support both DTE and DCE mode, depending on the mode of the interface cable attached to the port. To use a port as a DTE interface, you need only connect a DTE cable to the port. When the system detects the DTE mode cable, it automatically uses the external timing signal. To use a port in DCE mode, you must connect a DCE interface cable and set the clock speed with the **clock rate** configuration command. You must also set the clock rate to perform a loopback test. This section describes how to set the clock rate on a DCE port and, if necessary, how to invert the clock to correct a phase shift between the data and clock signals. [Table 5-4](#) summarizes some of the commands used to configure the clock rate. See the specific sections that follow for further details.

The PA-4T+ provides four synchronous serial ports, and each port supports full-duplex operations at T1 and E1 speeds. A single port can support up to E2 speeds.

Speed is controlled by three variables:

- the number of ports in use
- the maximum speed allowed by the port adapter
- the maximum speed of the attached CSU/DSU.

The CSU/DSU determines the maximum speed of the full-duplex port. No configuration is necessary. If a CSU/DSU runs at a maximum speed of 1.55 Mbps (T1 speed), using only one port in the port adapter will not make this CSU/DSU run at E2 speed. On the other hand, if a CSU/DSU is capable of E2 speed (8 Mbps), this CSU/DSU will take the maximum bandwidth of the port adapter. To ensure this speed, no other port can be used. If you use another port, the speed of the CSU/DSU capable of E2 speed is reduced, because the port adapter shares the bandwidth between the two ports.

The PA-4T+ maximum speed can be attained only if the maximum aggregate speed per port adapter is 8 Mbps (E2) when only one full-duplex port is in use. When two full-duplex ports are in use, the maximum speed for each is 4 Mbps. When four full-duplex ports are in use, the maximum speed for each is 1.55 Mbps (T1) or 2.048 Mbps (E1).

Table 5-4 Clock Rate Configuration Commands

Purpose	Command	Example	Additional Information
Set standard clock rate.	<b>clock rate</b>	The example is for a serial interface with a standard clock rate of 72 kbps.  Router(config)# <b>interface serial 3/0</b> Router(config-if)# <b>clock rate 7200</b>	<a href="#">“Setting the Clock Rate”</a>
Set nonstandard clock rate.	<b>clock rate</b>	The example is for a serial interface with a nonstandard clock rate of 1234567 kbps.  Router(config)# <b>interface serial 3/0</b> Router(config-if)# <b>clock rate 1234567</b>	<a href="#">“Setting the Clock Rate”</a>
Remove a clock rate that has been set.	<b>no clock rate</b>	The example is for a serial interface and removes a standard clock rate of 72 kbps.  Router(config)# <b>interface serial 3/0</b> Router(config-if)# <b>clock rate 7200</b> Router(config-if)# <b>no clock rate</b>	<a href="#">“Setting the Clock Rate”</a>
Invert the transmit clock signal.	<b>invert-txc</b>	The example inverts the transmit clock signal for a serial interface.  Router(config)# <b>interface serial 3/0</b> Router(config-if)# <b>invert-txc</b>	<a href="#">“Inverting the Clock Signal”</a>
Change the clock signal back to its original phase.	<b>no invert-txc</b>	The example sets the transmit clock signal for a serial interface back to its original phase.  Router(config)# <b>interface serial 3/0</b> Router(config-if)# <b>no invert-txc</b>	<a href="#">“Inverting the Clock Signal”</a>
Invert the data signal.	<b>invert data</b>	The example inverts the data stream for both transmit and receive for a serial interface:  Router(config)# <b>interface serial 3/0</b> Router(config-if)# <b>invert-txc</b>	<a href="#">“Inverting the Data Signal”</a>

## Setting the Clock Rate

The default operation on a PA-4T+ DCE interface is for the DCE device to generate its own clock signal (TxC) and send it to the remote DTE. The remote DTE device returns the clock signal to the DCE (PA-4T+). Set the clock rate of an interface using the **clock rate** subcommand, which specifies the clock rate as a bits-per-second value. This subcommand functions in the same way on all supported platforms.

Before you can assign a clock rate, you must use the **interface serial** command (followed by the interface address of the interface) to select the interface to which you want to assign the clock rate value.

In the following example, the clock rate is specified as 72 kbps:

```
Router(config-if)# clock rate 72000
```

The preceding command example applies to all systems in which the PA-4T+ is supported. Use the **no clock rate** command to remove the clock rate.

Following are the standard clock rates:

```
1200, 2400, 4800, 9600, 19200 38400, 56000, 64000,  
72000, 125000 148000, 250000, 500000, 800000, 1000000,  
1300000, 2000000, 4000000, 8000000
```

When you have finished, press **Ctrl-Z**—hold down the **Control** key while you press **Z**—or enter **end** or **exit** to exit configuration mode and return to the EXEC command interpreter prompt. Then write the new configuration to NVRAM using the **copy running-config startup-config** command.



#### Note

Cisco IOS Release 11.2(7a)P or later, or 11.1(10)CA or later loaded on your Cisco 7200 series router, Cisco 7000 series router, or Cisco 7500 series router with a VIP2-40(=) support nonstandard clock rates (any value from 1200 to 8000000) on PA-4T+ interfaces.

Cisco IOS Release 12.0(3)T or later, or 12.0(1)XE or later support nonstandard clock rates on PA-4T+ interfaces installed in Cisco 7204VXR router and Cisco 7206VXR router.

Cisco IOS Release 11.3(6)NA or later loaded on your Cisco uBR7200 series router supports nonstandard clock rates (any value from 1200 to 8000000) on PA-4T+ interfaces.

Set a nonstandard clock rate for an interface using the **clock rate** subcommand. Before you can assign a nonstandard clock rate, you must use the **interface serial** command (followed by the interface address of the interface) to select the interface to which you want to assign the nonstandard clock rate value.

In the following example, a nonstandard clock rate of 1234567 bps is specified:

```
Router(config-if)# clock rate 1234567
```

The preceding command example applies to all systems in which the PA-4T+ is supported. Use the **no clock rate** command to remove the clock rate.

When you have finished, press **Ctrl-Z**—hold down the **Control** key while you press **Z**—or enter **end** or **exit** to exit configuration mode and return to the EXEC command interpreter prompt.

Then write the new configuration to NVRAM using the **copy running-config startup-config** command.

The following example shows how to use the **show running-config** command to determine the exact clock rate to which the nonstandard clock rate was rounded:

```
Router# show running-config
Building configuration...
...
!
interface Serial11/0 (interface Serial13/1/0 on a VIP2 or FlexWAN module)

    no ip address
    clockrate 1151526
    !
...

```

In the preceding example, only the relevant output from the **show running-config** command is shown; other information is omitted.

## Inverting the Clock Signal

Systems that use long cables or cables that are not transmitting the TxC (clock) signal might experience high error rates when operating at higher transmission speeds. If a PA-4T+ DCE port is reporting a high number of error packets, a phase shift might be the problem. Inverting the clock might correct this shift.

When the PA-4T+ interface is a DTE, the **invert-txc** command inverts the TxC signal it receives from the remote DCE. When the PA-4T+ interface is a DCE, this command inverts the clock signal to the remote DTE port. Use the **no invert-txc** command to change the clock signal back to its original phase.

## Inverting the Data Signal

If the interface on the PA-4T+ synchronous serial port adapter is used to drive a dedicated T1 line that does not have B8ZS encoding (a method to avoid 15 zeros), the data stream must be inverted (both TxD and RxD) either in the connecting CSU/DSU or the interface. To invert the data stream coming out of the PA-4T+, use the **invert data** command. By inverting the (HDLC) data stream, the HDLC zero insertion algorithm becomes a ones insertion algorithm that satisfies the T1 requirements.



### Note

Invert data *only* on the PA-4T+ interface *or* on the CSU/DSU; inverting both cancels out both data inversions.

## Configuring NRZI Format

All PA-4T+ interfaces support nonreturn-to-zero (NRZ) and nonreturn-to-zero inverted (NRZI) formats. Both formats use two different voltage levels for transmission. NRZ signals maintain constant voltage levels with no signal transitions (no return to a zero voltage level) during a bit interval and are decoded using absolute values (0 and 1). NRZI uses the same constant signal levels but interprets the absence of data (a space) at the beginning of a bit interval as a signal transition and the presence of data (a mark) as no transition. NRZI uses relational encoding to decode signals rather than determining absolute values.

Table 5-5 summarizes NRZI format commands.

Table 5-5 NRZI Format Commands

Command	Purpose	Example
<b>nrzi-encoding [mark]</b> <sup>1</sup>	Enable NRZI encoding.	<p>The example is for a serial interface with NRZI mark encoding specified:</p> <pre>Router(config)# <b>interface serial 3/0</b> Router(config-if)# <b>nrzi-encoding mark</b></pre> <p>The example is for a serial interface with NRZI space encoding specified:</p> <pre>Router(config)# <b>interface serial 3/0</b> Router(config-if)# <b>nrzi-encoding</b></pre>
<b>no nrzi-encoding</b>	Disable NRZI encoding.	<p>The example disables NRZI encoding on a serial interface:</p> <pre>Router(config)# <b>interface serial 3/0</b> Router(config-if)# <b>no nrzi-encoding</b></pre>

- <sup>1</sup> *Mark* is an optional argument. When *mark* is used, it means there is no signal transition; there is data (a mark) at the beginning of a bit interval. When *mark* is not used, it means there is a signal transition; there is no data (a space) at the beginning of a bit interval.

NRZ format, the factory default on all interfaces, is most common. NRZI format, which is configured with a software command, is commonly used with EIA/TIA-232 connections in IBM environments.

Enable NRZI encoding on any interface using the **nrzi-encoding [mark]** command, where no argument after the command is interpreted as a signal transition, and **mark** is interpreted as no signal transition. This command functions in the same way on all supported platforms. Before you can enable NRZI encoding, you must use the **interface serial** command (followed by the interface address of the interface) to select the interface on which you want to enable NRZI encoding.

In the example that follows, NRZI encoding with a signal transition—no argument—is specified:

```
Router(config-if)# nrzi-encoding
```



In the example that follows, NRZI encoding with no signal transition—with argument—is specified:

```
Router(config-if)# nrzi-encoding mark
```

Use the **no nrzi-encoding** command to disable NRZI encoding.

When you have finished, press **Ctrl-Z**—hold down the **Control** key while you press **Z**—or enter **end** or **exit** to exit configuration mode and return to the EXEC command interpreter prompt. Then write the new configuration to NVRAM using the **copy running-config startup-config** command.

For complete command descriptions and instructions, refer to the *Configuration Fundamentals Configuration Guide* on Cisco.com.

## Configuring Cyclic Redundancy Checks

Cyclic redundancy check (CRC) is an error-checking technique that uses a calculated numeric value to detect errors in transmitted data. All interfaces use a 16-bit CRC (CRC-CITT) by default, but also support a 32-bit CRC. The sender of a data frame calculates the *frame check sequence* (FCS). Before it sends a frame, the sender appends the FCS value to the message. The receiver recalculates the FCS and compares its calculation to the FCS from the sender. If there is a difference between the two calculations, the receiver assumes that a transmission error occurred and sends a request to the sender to resend the frame.

Table 5-6 summarizes CRC commands.

**Table 5-6** CRC Commands

Command	Purpose	Example
<code>crc size</code>	Enable 32-bit CRC	The example enables 32-bit CRC on a serial interface: <pre>Router(config)# interface serial 3/0 Router(config-if)# crc 32</pre>
<code>no crc size</code>	Return to default 16-bit CRC.	The example disables 32-bit CRC on a serial interface and returns to the default 16-bit CRC: <pre>Router(config)# interface serial 3/0 Router(config-if)# no crc 32</pre>

Enable 32-bit CRC using the **crc 32** command. Before you can enable 32-bit CRC, you must use the **interface serial** command (followed by the interface address of the interface) to select the interface on which you want to enable 32-bit CRC. This command functions in the same way on all supported platforms.

In the example that follows, 32-bit CRC is specified:

```
Router(config-if)# crc 32
```

The preceding command example applies to all systems in which the PA-4T+ is supported. Use the **no crc 32** command to disable CRC-32 and return the interface to the default CRC-16 (CRC-CITT) setting.

When you have finished, press **Ctrl-Z**—hold down the **Control** key while you press **Z**—or enter **end** or **exit** to exit configuration mode and return to the EXEC command interpreter prompt. Then write the new configuration to NVRAM using the **copy running-config startup-config** command.

For command descriptions, refer to the *Configuration Fundamentals Configuration Guide* on Cisco.com.

**Note**

If you are configuring a PA-4T+ in a Cisco 7200 series router and you want to configure the interface for half-duplex or Bisync operation, proceed to the next section, “[Configuring Half-Duplex and Binary Synchronous Communications in Cisco 7200 Series Routers](#)”; otherwise, proceed to the “[Checking the Configuration](#)” section on page 5-18.

## Configuring Half-Duplex and Binary Synchronous Communications in Cisco 7200 Series Routers

This section explains how to configure PA-4T+ interfaces for half-duplex and Bisync operation in Cisco 7200 series routers, including Cisco 7200 VXR routers and Cisco 7201 routers.

**Note**

Cisco IOS Release 11.2(7a)P or a later release of 11.2P supports half-duplex and Bisync operation on the PA-4T+ in Cisco 7200 series routers.

Cisco IOS Release 11.1(19)CC1 or a later release of 11.1 CC, or Release 11.3(4)AA or a later release of 11.3AA supports half-duplex and Bisync operation on the PA-4T+ installed in Cisco 7202 routers.

Cisco IOS Release 12.0(3)T or a later release of 12.0T, or Release 12.0(2)XE or a later release of 12.0XE supports half-duplex and Bisync operation on the PA-4T+ in the Cisco 7204VXR router and Cisco 7206VXR router.

The Catalyst RSM/VIP2, Catalyst 6000 family FlexWAN module, Cisco 7100 series routers, Cisco uBR7200 series routers, and the VIP do *not* support half-duplex and Bisync operation on the PA-4T+.

Use the **half-duplex** command to configure PA-4T+ interfaces for half-duplex mode; full-duplex mode is the default for low-speed serial interfaces. Serial DCE interfaces in half-duplex mode can be configured for controlled-carrier mode or constant-carrier mode; constant-carrier mode is the default. Controlled-carrier mode sets the PA-4T+ interface to deactivate data carrier detect (DCD) until a transmission is sent to the interface. After a transmission is received, DCD is activated and the interface waits a user-configured amount of time, and then transmits the data. After the transmission, the interface waits a user-configured amount of time and then deactivates DCD. Constant-carrier mode activates DCD at all times.

Use the **half-duplex controlled-carrier** command to configure a PA-4T+ interface for controlled-carrier mode. Use the **no half-duplex controlled-carrier** command to return the interface to constant-carrier mode.

Follow these steps to configure controlled-carrier mode on a PA-4T+ interface:

- Step 1** Enter configuration mode and specify that the console terminal is the source of the configuration subcommands, as follows:

```
Router# configure terminal
Enter configuration commands, one per line. End with CNTL/Z.
Router(config)#
```

- Step 2** Specify the interface to configure for controlled-carrier mode using the **interface serial** subcommand (followed by the interface address of the interface) and then enter the **half-duplex controlled-carrier** subcommand.

The following example is for the first interface of the port adapter in port adapter slot 1:

```
Router(config)# interface serial 1/0
Router(config-if)# half-duplex controlled-carrier
```

- Step 3** Specify the length of the timer delay the interface uses when it is configured for controlled-carrier mode by using the following command:

```
Router(config-if)# half-duplex timer {cts-delay value | cts-drop-timeout value |
dcd-drop-delay value | dcd-txstart-delay value | rts-drop-delay value | rts-timeout value
| transmit-delay value}
```

where *value* is the length of the timer delay in milliseconds.

The following example specifies a Data Carrier Detect (DCD) drop delay of 100 milliseconds on the first interface of a port adapter in port adapter slot 1:

```
Router(config)# interface serial 1/0
Router(config-if)# half-duplex timer dcd-drop-delay 100 ms
```

[Table 5-7](#) lists the default delay settings and the *value* argument for each timer you can use with the **half-duplex timer** command.

**Table 5-7** Half-Duplex Timer Default Delay Settings

Timer	Command Syntax	Default Settings <sup>1</sup>
CTS delay <sup>2</sup>	<b>half-duplex timer cts-delay</b>	0
CTS drop timeout	<b>half-duplex timer cts-drop-timeout</b>	250
DCD drop delay <sup>3</sup>	<b>half-duplex timer dcd-drop-delay</b>	100
DCD transmission start delay	<b>half-duplex timer dcd-txstart-delay</b>	100
RTS drop delay <sup>4</sup>	<b>half-duplex timer rts-drop-delay</b>	3
RTS timeout	<b>half-duplex timer rts-timeout</b>	3
Transmit delay	<b>half-duplex transmit-delay</b>	0

1. In milliseconds (ms).
2. Clear To Send (CTS).
3. Data Carrier Detect (DCD).
4. Request To Send (RTS).

- Step 4** Complete the configuration by pressing **Ctrl-Z**—hold down the **Control** key while you press **Z**—or entering **end** or **exit** to exit configuration mode and return to the EXEC command interpreter prompt.

**Step 5** Write the new configuration to NVRAM as follows:

```
Router# copy running-config startup-config
[OK]
Router#
```

---

This completes the procedure for configuring controlled-carrier mode on a PA-T4+ interface. For additional information on configuring half-duplex operation on low-speed serial interfaces, refer to the chapter “Configuring Interfaces” of the *Configuration Fundamentals Configuration Guide* on Cisco.com.



**Note**

To configure PA-4T+ interfaces for Binary Synchronous (Bisync) operation in Cisco 7200 series routers, refer to the “Block Serial Tunneling (BSTUN)” section of the “Configuring Serial Tunnel (STUN) and Block Serial Tunnel (BSTUN)” chapter of the *Bridging and IBM Networking Configuration Guide* on Cisco.com.

---

## Checking the Configuration

After configuring the new interface, use the **show** commands to display the status of the new interface or all interfaces and the **ping** and **loopback** commands to check connectivity.

This section contains the following subsections:

- [Using show Commands to Verify the New Interface Status, page 5-18](#)
- [Using the ping Command to Verify Network Connectivity, page 5-33](#)
- [Using loopback Commands, page 5-34](#)

## Using show Commands to Verify the New Interface Status

[Table 5-8](#) demonstrates how you can use the **show** commands to verify that new interfaces are configured and operating correctly and that the PA-4T+ appears in them correctly. Sample displays of the output of selected **show** commands appear in the sections that follow. For complete command descriptions and examples, refer to the publications listed in the “[Related Documentation](#)” section on [page viii](#).



**Note**

The outputs that appear in this document may not match the output you receive when running these commands. The outputs in this document are examples only.

---

Table 5-8 Using show Commands

Command	Function	Example
<b>show version</b> or <b>show hardware</b>	Displays system hardware configuration, the number of each interface type installed, Cisco IOS software version, names and sources of configuration files, and boot images	Router# <b>show version</b>
<b>show controllers</b>	Displays all the current interface processors and their interfaces	Router# <b>show controllers</b>
<b>show diag slot</b> <b>Note</b> The <i>slot</i> argument is not required with Catalyst 5000 family switches.	Displays types of port adapters installed in your system and information about a specific port adapter slot, interface processor slot, or chassis slot	Router# <b>show diag 2</b>
<b>show interfaces type 0</b> or <b>1/</b> <i>interface-port-number</i>	Displays status information about a specific type of interface (for example, serial) on a Catalyst RSM/VIP2	Router# <b>show interfaces serial 1/0</b>
<b>show interfaces type module-slot-</b> <i>number/port-adapter-bay-number/</i> <i>interface-port-number</i>	Displays status information about a specific type of interface (for example, serial) on a Catalyst 6000 family FlexWAN module	Router# <b>show interfaces serial 3/0/0</b>
<b>show interfaces type 3/</b> <i>interface-port-</i> <i>number</i>	Displays status information about a specific type of interface (for example, serial) in a Cisco 7120 series router	Router# <b>show interfaces serial 3/1</b>
<b>show interfaces type 4/</b> <i>interface-port-</i> <i>number</i>	Displays status information about a specific type of interface (for example, serial) in a Cisco 7140 series router	Router# <b>show interfaces serial 4/1</b>
<b>show interfaces type</b> <i>slot-number/interface-port-</i> <i>number</i>	Displays status information about a specific type of interface (for example, serial) on a Cisco 7200 series router, Cisco 7200 VXR routers, Cisco 7201 router, Cisco 7301 router, or Cisco 7401ASR router	Router# <b>show interfaces serial 1/0</b>
<b>show interfaces type 1/</b> <i>interface-port-</i> <i>number</i>	Displays status information about a specific type of interface (for example, serial) in a Cisco uBR7223 router	Router# <b>show interfaces serial 1/1</b>

Table 5-8 Using show Commands (continued)

Command	Function	Example
<b>show interfaces</b> <i>type 1 or 2/</i> <i>interface-port-number</i>	Displays status information about a specific type of interface (for example, serial) in a Cisco uBR7246 router	Router# <b>show interfaces serial 2/0</b>
<b>show interfaces</b> <i>type 2 or 3 or 4 or 5/</i> <i>interface-port-number</i>	Displays status information about a serial interface on a Cisco 7304 PCI Port Adapter Carrier Card in a Cisco 7304 router	Router# <b>show interfaces serial 3/0</b>
<b>show interfaces</b> <i>type interface-processor-</i> <i>slot-number/port-adapter-slot-number/</i> <i>interface-port-number</i>	Displays status information about a specific type of interface (for example, serial) on a VIP in a Cisco 7000 series or Cisco 7500 series router	Router# <b>show interfaces serial 3/1/0</b>
<b>show protocols</b>	Displays protocols configured for the entire system and for specific interfaces	Router# <b>show protocols</b>
<b>show running-config</b>	Displays the running configuration file	Router# <b>show running-config</b>
<b>show startup-config</b>	Displays the configuration stored in NVRAM	Router# <b>show startup-config</b>

If an interface is shut down and you configured it as up, or if the displays indicate that the hardware is not functioning properly, ensure that the interface is properly connected and terminated. If you still have problems bringing up the interface, contact a service representative for assistance. This section includes the following subsections:

- [Using the show version or show hardware Commands, page 5-20](#)
- [Using the show diag Command, page 5-25](#)
- [Using the show interfaces Command, page 5-28](#)

Choose the subsection appropriate for your system. Proceed to the [“Using the ping Command to Verify Network Connectivity”](#) section on page 5-33 when you have finished using the **show** commands.

## Using the show version or show hardware Commands

Display the configuration of the system hardware, the number of each interface type installed, the Cisco IOS software version, the names and sources of configuration files, and the boot images, using the **show version** (or **show hardware**) command.



### Note

The outputs that appear in this document may not match the output you receive when running these commands. The outputs in this document are examples only.

The following sections provide platform-specific output examples using the **show version** command:

- [Catalyst RSM/VIP2 in Catalyst 5000 Family Switches—Example Output of the show version Command, page 5-21](#)
- [Catalyst 6000 Family FlexWAN Module in Catalyst 6000 Family Switches—Example Output of the show version Command, page 5-22](#)
- [Cisco 7100 Series Routers, Cisco 7200 Series Routers, Cisco 7200 VXR Routers, and Cisco uBR7200 Series Routers—Example Output of the show version Command, page 5-22](#)
- [Cisco 7201 Router—Example Output of the show version Command, page 5-23](#)
- [Cisco 7401ASR Router—Example Output of the show version Command, page 5-24](#)
- [VIP in Cisco 7000 Series Routers and Cisco 7500 Series Routers—Example Output of the show version Command, page 5-24](#)

### Catalyst RSM/VIP2 in Catalyst 5000 Family Switches—Example Output of the show version Command

Following is an example of the **show version** command from a Catalyst 5000 family switch with the PA-4T+ installed:

```
Router# show version

Cisco Internetwork Operating System Software
IOS (tm) GS Software (image-name), Version 11.1(8)CA, RELEASED SOFTWARE
Synced to mainline version: 11.1(8)
Copyright (c) 1986-1997 by cisco Systems, Inc.
Compiled Thu 23-Jan-97 18:14 by bellb
Image text-base: 0x60010900, data-base: 0x609EE000

ROM: System Bootstrap, Version 11.5 [kmac 3.2], RELEASED SOFTWARE
ROM: GS Software (image-name), Released version 11.1(5) [sglee 112]

GEN1 uptime is 2 minutes
System restarted by reload
System image file is "image-name", booted via tftp from 10.10.10.1

cisco RSP2 (R4600) processor with 32768K bytes of memory.
R4600 processor, Implementation 32, Revision 2.0
Last reset from power-on
G.703/E1 software, Version 1.0.
SuperLAT software copyright 1990 by Meridian Technology Corp).
Bridging software.
X.25 software, Version 2.0, NET2, BFE and GOSIP compliant.
TN3270 Emulation software (copyright 1994 by TGV Inc).
Chassis Interface.
1 VIP2 controller (4 Ethernet)(4 Serial).
4 Ethernet/IEEE 802.3 interfaces.
4 Network Serial interfaces.
125K bytes of non-volatile configuration memory.

16384K bytes of Flash PCMCIA card at slot 1 (Sector size 128K).
8192K bytes of Flash internal SIMM (Sector size 256K).
Configuration register is 0x0
```

## Catalyst 6000 Family FlexWAN Module in Catalyst 6000 Family Switches—Example Output of the show version Command

Following is an example of the **show version** command from a Catalyst 6000 family switch with a PA-4T+ installed:

```
Router# show version

Cisco Internetwork Operating System Software
IOS (tm) MSFC Software (C6MSFC-JSV-M), Experimental Version 12.1(20000209:134547)
[amcrae-cosmos_e_nightly 163]
Copyright (c) 1986-2000 by cisco Systems, Inc.
Compiled Wed 09-Feb-00 07:10 by
Image text-base: 0x60008900, data-base: 0x6140E000

ROM: System Bootstrap, Version 12.0(3)XE, RELEASE SOFTWARE

const-uut uptime is 5 minutes
System returned to ROM by reload
System image file is "bootflash:c6msfc-jsv-mz.Feb9"

cisco Cat6k-MSFC (R5000) processor with 122880K/8192K bytes of memory.
Processor board ID SAD03457061
R5000 CPU at 200Mhz, Implementation 35, Rev 2.1, 512KB L2 Cache
Last reset from power-on
Channelized E1, Version 1.0.
Bridging software.
X.25 software, Version 3.0.0.
SuperLAT software (copyright 1990 by Meridian Technology Corp).
TN3270 Emulation software.
Primary Rate ISDN software, Version 1.1.
6 FlexWAN controllers (13 Serial)(8 E1)(8 T1)(2 HSSI)(2 ATM)(1 Channelized T3)(1
Channelized E3)(2 POS).
1 Virtual Ethernet/IEEE 802.3 interface(s)
17 Serial network interface(s)
2 HSSI network interface(s)
2 ATM network interface(s)
2 Packet over SONET network interface(s)
1 Channelized T3 port(s)
1 Channelized E3 port(s)
123K bytes of non-volatile configuration memory.
4096K bytes of packet SRAM memory.

16384K bytes of Flash internal SIMM (Sector size 256K).
Configuration register is 0x1
```

## Cisco 7100 Series Routers, Cisco 7200 Series Routers, Cisco 7200 VXR Routers, and Cisco uBR7200 Series Routers—Example Output of the show version Command

Following is an example of the **show version** command from a Cisco 7200 series router with a PA-4T+ installed:

```
Router# show version

Cisco Internetwork Operating System Software
IOS (tm) 7200 Software (C7200-J-M), RELEASED VERSION 11.1(8)CA [sglee 108]
Synced to mainline version: 11.1
Copyright (c) 1986-1997 by cisco Systems, Inc.
Compiled Thu 27-Feb-97 23:54 by sglee
Image text-base: 0x600088F0, data-base: 0x6072C000

ROM: System Bootstrap, Version 11.1(5) RELEASED SOFTWARE
ROM: 7200 Software (software-image), Released Version 11.1(8)CA [sglee 101]
```



```

pulp uptime is 2 hours, 19 minutes
System restarted by reload
System image file is "image-name", booted via tftp from 10.10.10.1

cisco 7206 (NPE150) processor with 26624K/6144K bytes of memory.
R4700 processor, Implementation 33, Revision 1.0 (512KB Level 2 Cache)
Last reset from power-on
Bridging software.
SuperLAT software copyright 1990 by Meridian Technology Corp).
X.25 software, Version 2.0, NET2, BFE and GOSIP compliant.
TN3270 Emulation software (copyright 1994 by TGV Inc).
Chassis Interface.
3 Ethernet/IEEE 802.3 interfaces.
1 FastEthernet/IEEE 802.3 interface.
4 Serial interfaces.
125K bytes of non-volatile configuration memory.
1024K bytes of packet SRAM memory.

8192K bytes of Flash PCMCIA card at slot 0 (Sector size 128K).
4096K bytes of Flash internal SIMM (Sector size 256K).
Configuration register is 0x0

```

### Cisco 7201 Router—Example Output of the show version Command

Following is an example of the **show version** command from a Cisco 7201 router:

```

Router# show version

Cisco IOS Software, 7200 Software (C7200P-ADVENTERPRISEK9-M), Version
12.4(biffDEV.061001), INTERIM SOFTWARE Copyright (c) 1986-2006 by Cisco Systems, Inc.
Compiled Sun 01-Oct-06 23:42 by biff
ROM: System Bootstrap, Version 12.4(4r)XD5, RELEASE SOFTWARE (fc1)
BOOTLDR: Cisco IOS Software, 7200 Software (C7200P-KBOOT-M), Version 12.4(TAZ3DEV.060927),
INTERIM SOFTWARE
c7201alpha1 uptime is 5 days, 18 hours, 32 minutes System returned to ROM by power-on
System image file is "disk0:c7200p-adventerprisek9-mz.2006-10-01.biffdev"
This product contains cryptographic features and is subject to United States and local
country laws governing import, export, transfer and use. Delivery of Cisco cryptographic
products does not imply third-party authority to import, export, distribute or use
encryption.
Importers, exporters, distributors and users are responsible for compliance with U.S. and
local country laws. By using this product you agree to comply with applicable laws and
regulations. If you are unable to comply with U.S. and local laws, return this product
immediately.
A summary of U.S. laws governing Cisco cryptographic products may be found at:
http://www.cisco.com/wwl/export/crypto/tool/stqrg.html
If you require further assistance please contact us by sending email to export@cisco.com.
Cisco 7201 (c7201) processor (revision A) with 917504K/65536K bytes of memory.
Processor board ID 222222222222
MPC7448 CPU at 1666Mhz, Implementation 0, Rev 2.2
1 slot midplane, Version 2.255
Last reset from power-on
1 FastEthernet interface
4 Gigabit Ethernet interfaces
2045K bytes of NVRAM.
62443K bytes of USB Flash usbflash0 (Read/Write)
250880K bytes of ATA PCMCIA card at slot 0 (Sector size 512 bytes).
65536K bytes of Flash internal SIMM (Sector size 512K).
Configuration register is 0x2

```

### Cisco 7401ASR Router—Example Output of the show version Command

Following is an example of the **show version** command from a Cisco 7401ASR router with a PA-4T+ installed:

```
Router# show version

Cisco Internetwork Operating System Software
IOS (tm) 7401ASR Software (C7401ASR-J-M), RELEASED VERSION 11.1(8)CA [sglee 108]
Synced to mainline version: 11.1
Copyright (c) 1986-1997 by cisco Systems, Inc.
Compiled Thu 27-Feb-97 23:54 by sglee
Image text-base: 0x600088F0, data-base: 0x6072C000

ROM: System Bootstrap, Version 11.1(5) RELEASED SOFTWARE
ROM: 7401ASR Software (software-image), Released Version 11.1(8)CA [sglee 101]

pulp uptime is 2 hours, 19 minutes
System restarted by reload
System image file is "image-name", booted via tftp from 10.10.10.1

cisco 7206 (NP150) processor with 26624K/6144K bytes of memory.
R4700 processor, Implementation 33, Revision 1.0 (512KB Level 2 Cache)
Last reset from power-on
Bridging software.
SuperLAT software copyright 1990 by Meridian Technology Corp).
X.25 software, Version 2.0, NET2, BFE and GOSIP compliant.
TN3270 Emulation software (copyright 1994 by TGV Inc).
Chassis Interface.
3 Ethernet/IEEE 802.3 interfaces.
1 FastEthernet/IEEE 802.3 interface.
4 Serial interfaces.
125K bytes of non-volatile configuration memory.
1024K bytes of packet SRAM memory.

8192K bytes of Flash PCMCIA card at slot 0 (Sector size 128K).
4096K bytes of Flash internal SIMM (Sector size 256K).
Configuration register is 0x0
```

### VIP in Cisco 7000 Series Routers and Cisco 7500 Series Routers—Example Output of the show version Command

Following is an example of the **show version** command from a Cisco 7500 series router with a PA-4T+ installed:

```
Router# show version

Cisco Internetwork Operating System Software
IOS (tm) GS Software (image-name), Version 11.1(8)CA, RELEASED SOFTWARE
Synced to mainline version: 11.1(8)
Copyright (c) 1986-1997 by cisco Systems, Inc.
Compiled Thu 23-Jan-97 18:14 by bellb
Image text-base: 0x60010900, data-base: 0x609EE000

ROM: System Bootstrap, Version 11.5 [kmac 3.2], RELEASED SOFTWARE
ROM: GS Software (image-name), Released version 11.1(5) [sglee 112]

GEN1 uptime is 2 minutes
System restarted by reload
System image file is "image-name", booted via tftp from 10.10.10.1

cisco RSP2 (R4600) processor with 32768K bytes of memory.
R4600 processor, Implementation 32, Revision 2.0
```

```
Last reset from power-on
G.703/E1 software, Version 1.0.
SuperLAT software copyright 1990 by Meridian Technology Corp).
Bridging software.
X.25 software, Version 2.0, NET2, BFE and GOSIP compliant.
TN3270 Emulation software (copyright 1994 by TGV Inc).
Chassis Interface.
1 VIP2 controller (4 Ethernet)(4 Serial).
4 Ethernet/IEEE 802.3 interfaces.
4 Network Serial interfaces.
125K bytes of non-volatile configuration memory.

16384K bytes of Flash PCMCIA card at slot 1 (Sector size 128K).
8192K bytes of Flash internal SIMM (Sector size 256K).
Configuration register is 0x0
```

## Using the show diag Command

Display the types of port adapters installed in your system (and specific information about each) using the **show diag slot** command, where *slot* is the *port adapter slot* in a Catalyst 5000 family switch, a Cisco 7100 series router, Cisco 7200 series router, Cisco 7200 VXR router, Cisco uBR7200 series, Cisco 7201 router, Cisco 7301 router, and Cisco 7401ASR router, the *module slot* in a Cisco 7304 PCI Port Adapter Carrier Card in a Cisco 7304 router, and the *interface processor slot* in a Cisco 7000 series router or Cisco 7500 series router with a VIP. In the FlexWAN module, the **show diag** command is used without the *slot* designation.



---

**Note**

The outputs that appear in this document may not match the output you receive when running these commands. The outputs in this document are examples only.

---



---

**Note**

The *slot* argument is not required for Catalyst 5000 family switches.

---

The following sections provide platform-specific output examples using the **show diag** command:

- [Catalyst RSM/VIP2 in Catalyst 5000 Family Switches—Example Output of the show diag Command, page 5-26](#)
- [Catalyst 6000 Family FlexWAN Module—Example Output of the show diag Command, page 5-26](#)
- [Cisco 7100 Series Routers, Cisco 7200 Series Routers, Cisco 7200 VXR Routers, and Cisco uBR7200 Series Routers—Example Output of the show diag Command, page 5-26](#)
- [Cisco 7201 Router—Example Output of the show diag Command, page 5-27](#)
- [Cisco 7401ASR Router—Example Output of the show diag Command, page 5-27](#)
- [VIP in Cisco 7000 Series Routers and Cisco 7500 Series Routers—Example Output of the show diag Command, page 5-28](#)

### Catalyst RSM/VIP2 in Catalyst 5000 Family Switches—Example Output of the show diag Command

Following is an example of the **show diag** command that shows a PA-4T+ installed in a Catalyst RSM/VIP2:

```
Router# show diag 0
Slot 0:
  Physical slot 0, ~physical slot 0x6, logical slot 0, CBus 0
  Microcode Status 0xC
  Master Enable, LED, WCS Loaded
  Board is analyzed
  Pending I/O Status: Console I/O
  EEPROM format version 1
  VIP2 controller, HW rev 2.2, board revision UNKNOWN
  Serial number: 03517093 Part number: 73-1684-03
  Test history: 0x00          RMA number: 00-00-00
  Flags: cisco 7000 board; 7500 compatible

  EEPROM contents (hex):
    0x20: 01 15 02 03 00 35 AA A5 49 06 94 03 00 00 00 00
    0x30: 50 00 00 00 00 00 00 00 00 00 00 00 00 00 00 00

  Slot database information:
  Flags: 0x4          Insertion time: 0x5314 (01:20:55 ago)
[Additional display text omitted]
```

### Catalyst 6000 Family FlexWAN Module—Example Output of the show diag Command

Following is an example of the **show diag** command that shows a PA-4T+ installed in a Catalyst 6000 family FlexWAN module:

```
Router# show diag

[Additional display text omitted]

Slot 8: Logical_index 17
  Board is analyzed ipc ready FlexWAN controller

  Slot database information:
  Flags: 0x2004Insertion time: unknown

  CWAN Controller Memory Size: Unknown

  PA Bay 1 Information:
    Mx Serial PA, 8 ports
    EEPROM format version 0
    HW rev 0.00, Board revision UNKNOWN
    Serial number: 00000000 Part number: 00-0000-00
```

### Cisco 7100 Series Routers, Cisco 7200 Series Routers, Cisco 7200 VXR Routers, and Cisco uBR7200 Series Routers—Example Output of the show diag Command

Following is an example of the **show diag** command that shows a PA-4T+ installed in port adapter slot 1 of a Cisco 7200 series router:

```
Router# show diag 1
Slot 1:
  Mueslix serial (RS232) port adapter, 8 ports
  Port adapter is analyzed
  Port adapter insertion time 2d09h ago
```

```

Hardware revision 255.255                Board revision UNKNOWN
Serial number 4294967295                Part number 255-65535-255
Test history 0xFF                       RMA number 255-255-255
EEPROM format version 1
EEPROM contents (hex):
0x20: 01 0D FF FF FF FF FF FF FF FF FF FF FF FF FF FF
0x30: FF FF FF FF FF FF FF FF FF FF FF FF FF FF FF

```

### Cisco 7201 Router—Example Output of the show diag Command

Following is an example of the **show diag** command from a Cisco 7201 router:

```

Router# show diag 1
Slot 1:
Dual OC3 POS Port adapter, 2 ports
Port adapter is analyzed
Port adapter insertion time 00:02:19 ago
EEPROM contents at hardware discovery:
Hardware Revision : 1.0
PCB Serial Number : JAE07520DYL
Part Number : 73-8220-02
Board Revision : A0
RMA Test History : 00
RMA Number : 0-0-0-0
RMA History : 00
Deviation Number : 0
Product (FRU) Number : PA-POS-2OC3
Top Assy. Part Number : 800-21857-02
EEPROM format version 4
EEPROM contents (hex):
0x00: 04 FF 40 03 E3 41 01 00 C1 8B 4A 41 45 30 37 35
0x10: 32 30 44 59 4C 82 49 20 1C 02 42 41 30 03 00 81
0x20: 00 00 00 00 04 00 88 00 00 00 00 CB 94 50 41 2D
0x30: 50 4F 53 2D 32 4F 43 33 20 20 20 20 20 20 20 20
0x40: 20 C0 46 03 20 00 55 61 02 FF FF FF FF FF FF FF
0x50: FF FF FF FF FF FF FF FF FF FF FF FF FF FF FF
0x60: FF FF FF FF FF FF FF FF FF FF FF FF FF FF FF
0x70: FF FF FF FF FF FF FF FF FF FF FF FF FF FF FF

```

### Cisco 7401ASR Router—Example Output of the show diag Command

Following is an example of the **show diag** command that shows a PA-4T+ installed in port adapter slot 1 of a Cisco 7401ASR router:

```

Router# show diag 1
Slot 1:
Mueslix serial (RS232) port adapter, 8 ports
Port adapter is analyzed
Port adapter insertion time 2d09h ago
Hardware revision 255.255                Board revision UNKNOWN
Serial number 4294967295                Part number 255-65535-255
Test history 0xFF                       RMA number 255-255-255
EEPROM format version 1
EEPROM contents (hex):
0x20: 01 0D FF FF FF FF FF FF FF FF FF FF FF FF FF FF
0x30: FF FF FF FF FF FF FF FF FF FF FF FF FF FF FF

```

## VIP in Cisco 7000 Series Routers and Cisco 7500 Series Routers—Example Output of the show diag Command

Following is an example of the **show diag** command that shows a PA-4T+ installed in port adapter slot 0 on a VIP in interface processor slot 3:

```
Router# show diag 3
Slot 3:
  Physical slot 3, ~physical slot 0x6, logical slot 3, CBus 0
  Microcode Status 0xC
  Master Enable, LED, WCS Loaded
  Board is analyzed
  Pending I/O Status: Console I/O
  EEPROM format version 1
  VIP2 controller, HW rev 2.2, board revision UNKNOWN
  Serial number: 03517093 Part number: 73-1684-03
  Test history: 0x00          RMA number: 00-00-00
  Flags: cisco 7000 board; 7500 compatible

  EEPROM contents (hex):
    0x20: 01 15 02 03 00 35 AA A5 49 06 94 03 00 00 00 00
    0x30: 50 00 00 00 00 00 00 00 00 00 00 00 00 00 00 00

  Slot database information:
  Flags: 0x4          Insertion time: 0x5314 (01:20:55 ago)

  Controller Memory Size: 8 MBytes DRAM, 1024 KBytes SRAM

  PA Bay 0 Information:
    Mx Serial PA, 4 ports
    EEPROM format version 1
    HW rev 1.0, Board revision 154
    Serial number: 03699540 Part number: 73-1577-03

  PA Bay 1 Information:
    Ethernet PA, 4 ports
    EEPROM format version 1
    HW rev 1.0, Board revision 160
    Serial number: 02023164 Part number: 73-1556-03
```

## Using the show interfaces Command

Display status information (including the physical slot and interface address) for the interfaces you specify using the **show interfaces** command.

For complete descriptions of interface subcommands and the configuration options available for the individual platforms, refer to the publications listed in the [“Related Documentation” section on page viii](#).



### Note

The outputs that appear in this document may not match the output you receive when running these commands. The outputs in this document are examples only.

The following sections provide platform-specific output examples using the **show interfaces** command:

- [Catalyst RSM/VIP2 in Catalyst 5000 Family Switches—Example Output of the show interfaces Command, page 5-29](#)
- [Catalyst 6000 Family FlexWAN Module in Catalyst 6000 Family Switches—Example Output of the show interfaces Command, page 5-30](#)

- [Cisco 7100 Series Routers, Cisco 7200 Series Routers, Cisco 7200 VXR Routers, and Cisco uBR7200 Series Routers—Example Output of the show interfaces Command, page 5-30](#)
- [Cisco 7201 Router—Example Output of the show interfaces Command, page 5-31](#)
- [Cisco 7401ASR Router—Example Output of the show interfaces Command, page 5-32](#)
- [VIP in Cisco 7000 Series Routers or Cisco 7500 Series Routers—Example Output of the show interfaces Command, page 5-32](#)

### Catalyst RSM/VIP2 in Catalyst 5000 Family Switches—Example Output of the show interfaces Command

Following are examples of the **show interfaces serial** command for a Catalyst 5000 Family switch. In these examples, the eight serial interfaces (0 to 7) are on a port adapter in port adapter slot 1 of a Catalyst RSM/VIP2; also, most of the status information for each interface is omitted. (Interfaces are administratively shut down until you enable them.)

```
Router# show interfaces serial 1/0
Serial1/0 is up, line protocol is up
  Hardware is cyBus Serial
  Internet address is 10.10.10.1
  MTU 1500 bytes, BW 1544 Kbit, DLY 20000 usec, rely 255/255, load 1/255
  Encapsulation PPP, loopback not set, keepalive set (10 sec)
[Additional display text for remaining interfaces omitted]
```

```
Router# show interfaces serial 1/1
Serial1/1 is up, line protocol is up
  Hardware is cyBus Serial
  Internet address is 10.10.10.2
  MTU 1500 bytes, BW 1544 Kbit, DLY 20000 usec, rely 255/255, load 1/255
  Encapsulation PPP, loopback not set, keepalive set (10 sec)
[Additional display text for remaining interfaces omitted]
```

```
Router# show interfaces serial 1/2
Serial1/2 is up, line protocol is up
  Hardware is cyBus Serial
  Internet address is 10.10.10.3
  MTU 1500 bytes, BW 1544 Kbit, DLY 20000 usec, rely 255/255, load 1/255
  Encapsulation PPP, loopback not set, keepalive set (10 sec)
[Additional display text for remaining interfaces omitted]
```

```
Router# show interfaces serial 1/3
Serial1/3 is up, line protocol is up
  Hardware is cyBus Serial
  Internet address is 10.10.10.3
  MTU 1500 bytes, BW 1544 Kbit, DLY 20000 usec, rely 255/255, load 1/255
  Encapsulation PPP, loopback not set, keepalive set (10 sec)
[Additional display text for remaining interfaces omitted]
```

## Catalyst 6000 Family FlexWAN Module in Catalyst 6000 Family Switches—Example Output of the show interfaces Command

Following is an example of the **show interfaces serial** command for a Catalyst 6000 Family FlexWAN module in a Catalyst 6000 family switch. This example shows all of the information specific to interface port 0 on a PA-4T+ installed in port adapter slot 8 (interfaces are administratively shut down until you enable them):

```
Router# show interfaces serial 8/1/0
Serial8/1/0 is administratively down, line protocol is down
Hardware is Serial
MTU 1500 bytes, BW 1544 Kbit, DLY 20000 usec,
    reliability 255/255, txload 1/255, rxload 1/255
Encapsulation HDLC, crc 16, loopback not set
Keepalive not set
Last input never, output never, output hang never
Last clearing of "show interface" counters never
Queueing strategy: fifo
Output queue 0/40, 0 drops; input queue 0/75, 0 drops
5 minute input rate 0 bits/sec, 0 packets/sec
5 minute output rate 0 bits/sec, 0 packets/sec
    0 packets input, 0 bytes, 0 no buffer
Received 0 broadcasts, 0 runts, 0 giants, 0 throttles
0 input errors, 0 CRC, 0 frame, 0 overrun, 0 ignored, 0 abort
0 packets output, 0 bytes, 0 underruns
0 output errors, 0 collisions, 0 interface resets
0 output buffer failures, 0 output buffers swapped out
0 carrier transitions
RTS down, CTS down, DTR down, DCD down, DSR down
```

## Cisco 7100 Series Routers, Cisco 7200 Series Routers, Cisco 7200 VXR Routers, and Cisco uBR7200 Series Routers—Example Output of the show interfaces Command

Following are examples of the **show interfaces serial** command from a Cisco 7100 series routers. In these examples, the eight serial interfaces (0 to 7) are on a port adapter in port adapter slot 1; also, most of the status information for each interface is omitted. (Interfaces are administratively shut down until you enable them.)

```
Router# show interfaces serial 1/0
Serial1/0 is up, line protocol is up
Hardware is M4T
Internet address is 10.10.10.1
MTU 1500 bytes, BW 1544 Kbit, DLY 20000 usec, rely 255/255, load 1/255
Encapsulation PPP, loopback not set, keepalive set (10 sec)
(display text omitted)
```

```
Router# show interfaces serial 1/1
Serial1/1 is up, line protocol is up
Hardware is M4T
Internet address is 10.10.10.2
MTU 1500 bytes, BW 1544 Kbit, DLY 20000 usec, rely 255/255, load 1/255
Encapsulation PPP, loopback not set, keepalive set (10 sec)
(display text omitted)
```

```
Router# show interfaces serial 1/2
Serial1/2 is up, line protocol is up
Hardware is M4T
Internet address is 10.10.10.3
MTU 1500 bytes, BW 1544 Kbit, DLY 20000 usec, rely 255/255, load 1/255
Encapsulation PPP, loopback not set, keepalive set (10 sec)
(display text omitted)
```



```

Router# show interfaces serial 1/3
Serial1/3 is up, line protocol is up
  Hardware is M4T
  Internet address is 10.10.10.4
  MTU 1500 bytes, BW 1544 Kbit, DLY 20000 usec, rely 255/255, load 1/255
  Encapsulation PPP, loopback not set, keepalive set (10 sec)
(display text omitted)

```

Following is an example of the **show interfaces serial** command, which shows all of the information specific to interface port 0 on a PA-4T+ installed in port adapter slot 1:

```

Router# show interfaces serial 1/0
Serial1/0 is up, line protocol is up
  Hardware is M4T
  Internet address is 10.10.10.1
  MTU 1500 bytes, BW 1544 Kbit, DLY 20000 usec, rely 255/255, load 1/255
  Encapsulation PPP, loopback not set, keepalive set (10 sec)
  LCP Open
  Open: ipcp
  Last input 00:00:09, output 00:00:09, output hang never
  Last clearing of "show interface" counters never
  Input queue: 0/75/0 (size/max/drops); Total output drops: 0
  Queueing strategy: weighted fair
  Output queue: 0/64/0 (size/threshold/drops)
    Conversations 0/1 (active/max active)
    Reserved Conversations 0/0 (allocated/max allocated)
  5 minute input rate 0 bits/sec, 0 packets/sec
  5 minute output rate 0 bits/sec, 0 packets/sec
    1675 packets input, 26792 bytes, 0 no buffer
    Received 0 broadcasts, 0 runts, 0 giants
    0 input errors, 0 CRC, 0 frame, 0 overrun, 0 ignored, 0 abort
    1676 packets output, 26806 bytes, 0 underruns
    0 output errors, 0 collisions, 3 interface resets
    0 output buffer failures, 0 output buffers swapped out
    0 carrier transitions      DCD=up DSR=up DTR=up RTS=up CTS=up

```

### Cisco 7201 Router—Example Output of the show interfaces Command

Following is an example of the **show interfaces** command from a Cisco 7201 router:

```

Router# show interfaces
GigabitEthernet0/0 is up, line protocol is up
  Hardware is MV64460 Internal MAC, address is 0019.56c5.2adb (bia
0019.56c5.2adb)
  Internet address is 209.165.200.225
  MTU 1500 bytes, BW 1000000 Kbit, DLY 10 usec,
    reliability 255/255, txload 1/255, rxload 45/255
  Encapsulation ARPA, loopback not set
  Keepalive set (10 sec)
  Full-duplex, 1000Mb/s, media type is RJ45
  output flow-control is XON, input flow-control is XON
  ARP type: ARPA, ARP Timeout 04:00:00
  Last input 00:07:03, output 00:00:07, output hang never
  Last clearing of "show interface" counters 00:00:04
  Input queue: 0/75/0/0 (size/max/drops/flushes); Total output drops: 0
  Queueing strategy: fifo
  Output queue: 0/40 (size/max)
  5 minute input rate 180240000 bits/sec, 430965 packets/sec
  5 minute output rate 0 bits/sec, 0 packets/sec
    2222975 packets input, 133378500 bytes, 0 no buffer
    Received 0 broadcasts, 0 runts, 0 giants, 0 throttles
    0 input errors, 0 CRC, 0 frame, 0 overrun, 0 ignored

```

```

0 watchdog, 0 multicast, 0 pause input
0 input packets with dribble condition detected
0 packets output, 0 bytes, 0 underruns
0 output errors, 0 collisions, 0 interface resets
0 babbles, 0 late collision, 0 deferred
0 lost carrier, 0 no carrier, 0 pause output
0 output buffer failures, 0 output buffers swapped out

```

### Cisco 7401ASR Router—Example Output of the show interfaces Command

Following is an example of the **show interfaces serial** command from a Cisco 7401ASR router, which shows all of the information specific to interface port 0 on a PA-4T+ installed in port adapter slot 1:

```

Router# show interfaces serial 1/0
Serial1/0 is up, line protocol is up
  Hardware is M4T
  Internet address is 10.10.10.1
  MTU 1500 bytes, BW 1544 Kbit, DLY 20000 usec, rely 255/255, load 1/255
  Encapsulation PPP, loopback not set, keepalive set (10 sec)
  LCP Open
  Open: ipcp
  Last input 00:00:09, output 00:00:09, output hang never
  Last clearing of "show interface" counters never
  Input queue: 0/75/0 (size/max/drops); Total output drops: 0
  Queueing strategy: weighted fair
  Output queue: 0/64/0 (size/threshold/drops)
    Conversations 0/1 (active/max active)
    Reserved Conversations 0/0 (allocated/max allocated)
  5 minute input rate 0 bits/sec, 0 packets/sec
  5 minute output rate 0 bits/sec, 0 packets/sec
    1675 packets input, 26792 bytes, 0 no buffer
    Received 0 broadcasts, 0 runts, 0 giants
    0 input errors, 0 CRC, 0 frame, 0 overrun, 0 ignored, 0 abort
    1676 packets output, 26806 bytes, 0 underruns
    0 output errors, 0 collisions, 3 interface resets
    0 output buffer failures, 0 output buffers swapped out
    0 carrier transitions      DCD=up  DSR=up  DTR=up  RTS=up  CTS=up

```

### VIP in Cisco 7000 Series Routers or Cisco 7500 Series Routers—Example Output of the show interfaces Command

Following are examples of the **show interfaces serial** command from a VIP. In these examples, the eight serial interfaces (0 to 7) are on a port adapter in port adapter slot 1 of a VIP in interface processor slot 3; also, most of the status information for each interface is omitted. (Interfaces are administratively shut down until you enable them.)

```

Router# show interfaces serial 3/1/0
Serial3/1/0 is up, line protocol is up
  Hardware is cyBus Serial
  Internet address is 10.0.0.0
  MTU 1500 bytes, BW 1544 Kbit, DLY 20000 usec, rely 255/255, load 1/255
  Encapsulation HDLC, loopback not set, keepalive not set
  [Additional display text omitted from this example]

```

```

Router# show interfaces serial 3/1/1
Serial3/1/1 is up, line protocol is up
  Hardware is cyBus Serial
  Internet address is 10.0.0.1
  MTU 1500 bytes, BW 1544 Kbit, DLY 20000 usec, rely 255/255, load 1/255
  Encapsulation HDLC, loopback not set, keepalive not set
  [Additional display text omitted from this example]

```

```
Router# show interfaces serial 3/1/2
Serial3/1/2 is up, line protocol is up
  Hardware is cyBus Serial
  Internet address is 10.0.0.2
  MTU 1500 bytes, BW 1544 Kbit, DLY 20000 usec, rely 255/255, load 1/255
  Encapsulation HDLC, loopback not set, keepalive not set
[Additional display text for remaining interfaces omitted]
```

Following is an example of the **show interfaces serial** command, which shows all of the information specific to interface 0 on a port adapter in port adapter slot 1 of a VIP in interface processor slot 3:

```
Router# show interfaces serial 3/1/0
Serial3/1/0 is up, line protocol is up
  Hardware is cyBus Serial
  Internet address is 10.0.0.0
  MTU 1500 bytes, BW 1544 Kbit, DLY 20000 usec, rely 255/255, load 1/255
  Encapsulation HDLC, loopback not set, keepalive not set
  Last input 2d18h, output 00:00:54, output hang never
  Last clearing of "show interface" counters never
  Input queue: 0/75/0 (size/max/drops); Total output drops: 0
  Queueing strategy: weighted fair
  Output queue: 0/64/0 (size/threshold/drops)
    Conversations 0/1 (active/max active)
    Reserved Conversations 0/0 (allocated/max allocated)
  5 minute input rate 0 bits/sec, 0 packets/sec
  5 minute output rate 0 bits/sec, 0 packets/sec
    16 packets input, 1620 bytes, 0 no buffer
    Received 0 broadcasts, 0 runts, 0 giants
    0 input errors, 0 CRC, 0 frame, 0 overrun, 1 ignored, 0 abort
    3995 packets output, 1147800 bytes, 0 underruns
    0 output errors, 0 collisions, 0 interface resets
    0 output buffer failures, 0 output buffers swapped out
    1 carrier transitions
  RTS up, CTS up, DTR up, DCD up, DSR up
```

## Using the ping Command to Verify Network Connectivity

Using the **ping** command, you can verify that an interface port is functioning properly. This section provides a brief description of this command. Refer to the publications listed in the [“Related Documentation” section on page viii](#) for detailed command descriptions and examples.

The **ping** command sends an echo request out to a remote device at an IP address that you specify. After sending a series of signals, the command waits a specified time for the remote device to echo the signals. Each returned signal is displayed as an exclamation point (!) on the console terminal; each signal that is not returned before the specified time-out is displayed as a period (.). A series of exclamation points (!!!!!) indicates a good connection; a series of periods (.....) or the messages [timed out] or [failed] indicate that the connection failed.

Following is an example of a successful **ping** command to a remote server with the address 10.10.10.10:

```
Router# ping 10.10.10.10 <Return>
Type escape sequence to abort.
Sending 5, 100-byte ICMP Echoes to 10.10.10.10, timeout is 2 seconds:
!!!!
Success rate is 100 percent (5/5), round-trip min/avg/max = 1/15/64 ms
Router#
```

If the connection fails, verify that you have the correct IP address for the server and that the server is active (powered on), and repeat the **ping** command.

## Using loopback Commands

The loopback test allows you to detect and isolate equipment malfunctions by testing the connection between the PA-4T+ interface and a remote device such as modems or CSU/DSUs. The **loopback** subcommand sends a series of packets out to and through the device (or cable), and back to the PA-4T+ interface. If the packets complete the loop, the connection is good. If not, you can isolate a fault to the remote device or interface cable in the path of the loopback test.

**Note**

---

You must configure a clock rate on the port *before* performing a loopback test. However, if no cable is attached to the port, the port is administratively up, and the port is in loopback mode, you do not have to configure a clock rate on the port *before* performing a loopback test.

---

Depending on the mode of the port, issuing the **loopback** command checks the following path:

- When no interface cable is attached to the PA-4T+ interface, or if a DCE cable is attached to a port that is configured as line protocol up, the **loopback** command tests the path between the network processing engine and the interface port only (without leaving the network processing engine and port adapter).
- When a DTE cable is attached to the port, the **loopback** command tests the path between the network processing engine and the near (network processing engine) side of the DSU or modem to test the PA-4T+ interface and interface cable.

**Note**

---

The X.21 interface definition does not include a loopback definition. On the PA-4T+, the X.21 DTE interface does not support the loopback function. Because of the internal clock signal present on the PA-4T+ interfaces, loopback will function on an X.21 DCE interface.

---