



PA-8T-X21 Synchronous Serial Port Adapter Installation and Configuration

Product Number: PA-8T-X21(=)

Platforms Supported: Catalyst 5000 Series Switches with RSM/VIP2,
Catalyst 6000 Family Switches with FlexWAN Module, Cisco 7000 Series,
Cisco 7100 Series, Cisco 7200 Series, Cisco uBR7200 Series, Cisco 7301 Routers,
Cisco 7304 PCI Port Adapter Carrier Card in the Cisco 7304 Router, Cisco 7401ASR
Routers, and Cisco 7500 Series with VIP

Corporate Headquarters
Cisco Systems, Inc.
170 West Tasman Drive
San Jose, CA 95134-1706
USA
<http://www.cisco.com>
Tel: 408 526-4000
800 553-NETS (6387)
Fax: 408 526-4100



THE SPECIFICATIONS AND INFORMATION REGARDING THE PRODUCTS IN THIS MANUAL ARE SUBJECT TO CHANGE WITHOUT NOTICE. ALL STATEMENTS, INFORMATION, AND RECOMMENDATIONS IN THIS MANUAL ARE BELIEVED TO BE ACCURATE BUT ARE PRESENTED WITHOUT WARRANTY OF ANY KIND, EXPRESS OR IMPLIED. USERS MUST TAKE FULL RESPONSIBILITY FOR THEIR APPLICATION OF ANY PRODUCTS.

THE SOFTWARE LICENSE AND LIMITED WARRANTY FOR THE ACCOMPANYING PRODUCT ARE SET FORTH IN THE INFORMATION PACKET THAT SHIPPED WITH THE PRODUCT AND ARE INCORPORATED HEREIN BY THIS REFERENCE. IF YOU ARE UNABLE TO LOCATE THE SOFTWARE LICENSE OR LIMITED WARRANTY, CONTACT YOUR CISCO REPRESENTATIVE FOR A COPY.

The following information is for FCC compliance of Class A devices: This equipment has been tested and found to comply with the limits for a Class A digital device, pursuant to part 15 of the FCC rules. These limits are designed to provide reasonable protection against harmful interference when the equipment is operated in a commercial environment. This equipment generates, uses, and can radiate radio-frequency energy and, if not installed and used in accordance with the instruction manual, may cause harmful interference to radio communications. Operation of this equipment in a residential area is likely to cause harmful interference, in which case users will be required to correct the interference at their own expense.

The following information is for FCC compliance of Class B devices: The equipment described in this manual generates and may radiate radio-frequency energy. If it is not installed in accordance with Cisco's installation instructions, it may cause interference with radio and television reception. This equipment has been tested and found to comply with the limits for a Class B digital device in accordance with the specifications in part 15 of the FCC rules. These specifications are designed to provide reasonable protection against such interference in a residential installation. However, there is no guarantee that interference will not occur in a particular installation.

Modifying the equipment without Cisco's written authorization may result in the equipment no longer complying with FCC requirements for Class A or Class B digital devices. In that event, your right to use the equipment may be limited by FCC regulations, and you may be required to correct any interference to radio or television communications at your own expense.

You can determine whether your equipment is causing interference by turning it off. If the interference stops, it was probably caused by the Cisco equipment or one of its peripheral devices. If the equipment causes interference to radio or television reception, try to correct the interference by using one or more of the following measures:

- Turn the television or radio antenna until the interference stops.
- Move the equipment to one side or the other of the television or radio.
- Move the equipment farther away from the television or radio.
- Plug the equipment into an outlet that is on a different circuit from the television or radio. (That is, make certain the equipment and the television or radio are on circuits controlled by different circuit breakers or fuses.)

Modifications to this product not authorized by Cisco Systems, Inc. could void the FCC approval and negate your authority to operate the product.

The Cisco implementation of TCP header compression is an adaptation of a program developed by the University of California, Berkeley (UCB) as part of UCB's public domain version of the UNIX operating system. All rights reserved. Copyright © 1981, Regents of the University of California.

NOTWITHSTANDING ANY OTHER WARRANTY HEREIN, ALL DOCUMENT FILES AND SOFTWARE OF THESE SUPPLIERS ARE PROVIDED "AS IS" WITH ALL FAULTS. CISCO AND THE ABOVE-NAMED SUPPLIERS DISCLAIM ALL WARRANTIES, EXPRESSED OR IMPLIED, INCLUDING, WITHOUT LIMITATION, THOSE OF MERCHANTABILITY, FITNESS FOR A PARTICULAR PURPOSE AND NONINFRINGEMENT OR ARISING FROM A COURSE OF DEALING, USAGE, OR TRADE PRACTICE.

IN NO EVENT SHALL CISCO OR ITS SUPPLIERS BE LIABLE FOR ANY INDIRECT, SPECIAL, CONSEQUENTIAL, OR INCIDENTAL DAMAGES, INCLUDING, WITHOUT LIMITATION, LOST PROFITS OR LOSS OR DAMAGE TO DATA ARISING OUT OF THE USE OR INABILITY TO USE THIS MANUAL, EVEN IF CISCO OR ITS SUPPLIERS HAVE BEEN ADVISED OF THE POSSIBILITY OF SUCH DAMAGES.

CCIP, CCSP, the Cisco Arrow logo, the Cisco *Powered* Network mark, Cisco Unity, Follow Me Browsing, FormShare, and StackWise are trademarks of Cisco Systems, Inc.; Changing the Way We Work, Live, Play, and Learn, and iQuick Study are service marks of Cisco Systems, Inc.; and Aironet, ASIST, BPX, Catalyst, CCDA, CCDP, CCIE, CCNA, CCNP, Cisco, the Cisco Certified Internetwork Expert logo, Cisco IOS, the Cisco IOS logo, Cisco Press, Cisco Systems, Cisco Systems Capital, the Cisco Systems logo, Empowering the Internet Generation, Enterprise/Solver, EtherChannel, EtherSwitch, Fast Step, GigaStack, Internet Quotient, IOS, IP/TV, iQ Expertise, the iQ logo, iQ Net Readiness Scorecard, LightStream, MGX, MICA, the Networkers logo, Networking Academy, Network Registrar, *Packet*, PIX, Post-Routing, Pre-Routing, RateMUX, Registrar, ScriptShare, SlideCast, SMARTnet, StrataView Plus, Stratm, SwitchProbe, TeleRouter, The Fastest Way to Increase Your Internet Quotient, TransPath, and VCO are registered trademarks of Cisco Systems, Inc. and/or its affiliates in the U.S. and certain other countries.

All other trademarks mentioned in this document or Web site are the property of their respective owners. The use of the word partner does not imply a partnership relationship between Cisco and any other company. (0304R)

PA-8T-X21 Synchronous Serial Port Adapter Installation and Configuration

Copyright © 1996–2003, Cisco Systems, Inc.

All rights reserved.



Preface vii

Objectives	vii
Organization	viii
Related Documentation	viii
Obtaining Documentation	x
Cisco.com	x
Documentation CD-ROM	x
Ordering Documentation	xi
Documentation Feedback	xi
Obtaining Technical Assistance	xi
Cisco.com	xi
Technical Assistance Center	xii
Cisco TAC Website	xii
Cisco TAC Escalation Center	xiii
Obtaining Additional Publications and Information	xiii

CHAPTER 1

Overview 1-1

Port Adapter Overview	1-1
Serial Interface Specifications	1-2
LEDs	1-3
Cables and Pinouts	1-4
Port Adapter Slot Locations on the Supported Platforms	1-15
Catalyst RSM/VIP2 Slot Numbering	1-15
Catalyst 6000 Family FlexWAN Module Slot Numbering	1-16
Cisco 7100 Series Routers Slot Numbering	1-18
Cisco 7200 Series and Cisco uBR7200 Series Routers Slot Numbering	1-19
Cisco 7301 Router Slot Numbering	1-20
Cisco 7304 PCI Port Adapter Carrier Card Slot Numbering	1-20
Cisco 7401ASR Router Slot Numbering	1-22
VIP Slot Numbering	1-22
Identifying Interface Addresses	1-23
Catalyst RSM/VIP2 Interface Addresses	1-24
Catalyst 6000 Family FlexWAN Module Interface Addresses	1-24
Cisco 7100 Series Routers Interface Addresses	1-25

Cisco 7200 Series and Cisco uBR7200 Series Routers Interface Addresses	1-25
Cisco 7301 Router Interface Addresses	1-26
Cisco 7304 PCI Port Adapter Carrier Card Interface Addresses	1-26
Cisco 7401ASR Router Interface Addresses	1-26
VIP Interface Addresses	1-26

CHAPTER 2

Preparing for Installation 2-1

Required Tools and Equipment	2-1
Software and Hardware Requirements	2-2
Checking Hardware and Software Compatibility	2-3
Safety Guidelines	2-3
Safety Warnings	2-3
Electrical Equipment Guidelines	2-8
Telephone Wiring Guidelines	2-8
Preventing Electrostatic Discharge Damage	2-9
FCC Class A Compliance	2-9

CHAPTER 3

Removing and Installing Port Adapters 3-1

Handling Port Adapters	3-2
Online Insertion and Removal	3-2
Warnings and Cautions	3-3
Port Adapter Removal and Installation	3-4
Catalyst RSM/VIP2—Removing and Installing a Port Adapter	3-5
Catalyst 6000 Family FlexWAN Module—Removing and Installing a Port Adapter	3-6
Cisco 7100 Series—Removing and Installing a Port Adapter	3-7
Cisco 7200 Series—Removing and Installing a Port Adapter	3-8
Cisco uBR7200 Series—Removing a Port Adapter	3-9
Cisco uBR7200 Series—Installing a Port Adapter	3-10
Cisco 7301 Series—Removing and Installing a Port Adapter	3-11
Cisco 7304 PCI Port Adapter Carrier Card—Removing and Installing a Port Adapter	3-12
Cisco 7401ASR Router—Removing and Installing a Port Adapter	3-14
VIP—Removing and Installing a Port Adapter	3-15

CHAPTER 4

Attaching the PA-8T-X21 Interface Cables 4-1

Connecting a PA-8T-X21 Compact Serial Cable	4-1
Determining the Port Mode	4-3

Configuring the PA-8T-X21 Interfaces	5-1
Using the EXEC Command Interpreter	5-1
Configuring the Interfaces	5-2
Shutting Down an Interface	5-2
Performing a Basic Configuration	5-8
Configuring Timing (Clock) Signals	5-10
Setting the Clock Rate	5-11
Inverting the Clock Signal	5-12
Inverting the Data Signal	5-12
Configuring NRZI Format	5-13
Configuring Cyclic Redundancy Checks	5-14
Configuring Half-Duplex and Binary Synchronous Communications	5-15
Checking the Configuration	5-17
Using show Commands to Verify the New Interface Status	5-17
Using the show version Commands	5-19
Using the show diag Command	5-23
Using the show interfaces Command	5-26
Using the ping Command to Verify Network Connectivity	5-28
Using loopback Commands	5-28



Preface

This preface describes the objectives and organization of this document and explains how to find additional information on related products and services. This preface contains the following sections:

- [Objectives, page vii](#)
- [Organization, page viii](#)
- [Related Documentation, page viii](#)
- [Obtaining Documentation, page x](#)
- [Obtaining Technical Assistance, page xi](#)
- [Obtaining Additional Publications and Information, page xiii](#)

Objectives

This document describes how to install and configure the Cisco PA-8T-X21 synchronous serial port adapter (PA-8T-X21[=]) used in the following platforms:

- Catalyst 5000 family switches with the Route Switch Module (RSM)/second-generation Versatile Interface Processor (VIP2)
- Catalyst 6000 family switches with the Catalyst 6000 family FlexWAN module
- Cisco 7100 series routers—which consist of the Cisco 7120 series and Cisco 7140 series
- Cisco 7200 routers—which consist of the two-slot Cisco 7202, four-slot Cisco 7204 and Cisco 7204VXR, and the six-slot Cisco 7206 and the Cisco 7206VXR
- Cisco uBR7200 series universal broadband routers—which consist of the six-slot Cisco uBR7246 and the three-slot Cisco uBR7223
- Cisco 7301 router
- Cisco 7304 PCI Port Adapter Carrier Card in the Cisco 7304 router
- Cisco 7401ASR routers
- Versatile Interface Processor (VIP) in Cisco 7500 series and Cisco 7000 series routers with the 7000 series Route Switch Processor (RSP7000) and 7000 series Chassis Interface (RSP7000CI)

Organization

This document is organized into the following chapters:

Section	Title	Description
Chapter 1	Overview	Describes the PA-8T-X21 synchronous serial port adapter and describes its LED displays, cables, and receptacles.
Chapter 2	Preparing for Installation	Describes safety considerations, tools required, and procedures you should perform before the actual port adapter installation.
Chapter 3	Removing and Installing Port Adapters	Describes the procedures for installing and removing port adapters in the supported platforms.
Chapter 4	Attaching the PA-8T-X21 Interface Cables	Provides instructions for installing port adapter cables on the supported platforms.
Chapter 5	Configuring the PA-8T-X21 Interfaces	Provides instructions for configuring your port adapter on the supported platforms. The instructions given in this chapter apply to all supported platforms described in this document.

Related Documentation

Your router or switch and the Cisco IOS software running on it contain extensive features and functionality, which are documented in the following resources:

- Cisco IOS software:

For configuration information and support, refer to the modular configuration and modular command reference publications in the Cisco IOS software configuration documentation set that corresponds to the software release installed on your Cisco hardware.



Note You can access Cisco IOS software configuration and hardware installation and maintenance documentation on the World Wide Web at <http://www.cisco.com>, <http://www-china.cisco.com>, or <http://www-europe.cisco.com>.

- Catalyst RSM/VIP2

For hardware installation and maintenance information, refer to the following publications:

- *Route Switch Module Catalyst VIP2-15 and VIP2-40 Installation and Configuration Note*
- *Catalyst 5000 Series Route Switch Module Installation and Configuration Note*
- The installation and configuration guide that shipped with your Catalyst 5000 family switch

- Catalyst 6000 family FlexWAN module

For hardware installation and maintenance information, refer to the following publications:

- *Catalyst 6000 Family FlexWAN Module Installation and Configuration Note*
- The installation and configuration guide that shipped with your Catalyst 6000 family switch

- Cisco 7000 series routers
For hardware installation and maintenance information, refer to the following publications:
 - *Cisco 7000 Hardware Installation and Maintenance* that shipped with your router
 - *Second-Generation Versatile Interface Processor (VIP2) Installation and Configuration*
 - *Fourth-Generation Versatile Interface Processor (VIP4) Installation and Configuration*
 - *Versatile Interface Processor (VIP6-80) Installation and Configuration*
- Cisco 7100 series routers:
 - For hardware installation and maintenance information, refer to the *Cisco 7100 Series VPN Router Installation and Configuration Guide* that shipped with your Cisco 7100 series router.
 - For information on setting up a Virtual Private Network, refer to the *Cisco 7100 Series VPN Configuration Guide*.
- Cisco 7200 series routers:
 - For port adapter hardware and memory configuration guidelines, refer to the *Cisco 7200 Series Port Adapter Hardware Configuration Guidelines*.
 - For hardware installation and maintenance information (including the Cisco 7206 or Cisco 7206VXR as a router shelf in a Cisco AS5800 Universal Access Server), refer to the installation and configuration guide that shipped with your Cisco 7200 series router.
- Cisco 7200 VXR routers:
For hardware installation and maintenance information, refer to the *Cisco 7200 VXR Installation and Configuration Guide* that shipped with your Cisco 7200 VXR router.
- Cisco uBR7200 series routers:
For installation and maintenance information, refer to the hardware installation and software configuration guides for the Cisco uBR7200 series router.
- Cisco 7301 router:
 - For hardware installation and maintenance information, refer to the *Cisco 7301 Installation and Configuration Guide* or the *Cisco 7301 Router Quick Start Guide*.
- Cisco 7304 PCI Port Adapter Carrier Card in Cisco 7304 routers:
For hardware installation and maintenance information, refer to the *Cisco 7304 PCI Port Adapter Carrier Card Installation and Configuration Guide*.
- Cisco 7401ASR routers:
For hardware installation and maintenance information, refer to the *Cisco 7401ASR Installation and Configuration Guide* or the *Cisco 7401ASR Quick Start Guide*.
- Cisco 7500 series routers:
For hardware installation and maintenance information, refer to the following publications:
 - *Cisco 7500 Installation and Configuration* or the quick start guide that shipped with your router
 - *Second-Generation Versatile Interface Processor (VIP2) Installation and Configuration*
 - *Fourth-Generation Versatile Interface Processor (VIP4) Installation and Configuration*
 - *Versatile Interface Processor (VIP6-80) Installation and Configuration*

- For international agency compliance, safety, and statutory information for WAN interfaces:
 - *Site Preparation and Safety Guide*
 - *Regulatory Compliance and Safety Information for Cisco 7000 Series Routers*
 - *Regulatory Compliance and Safety Information for Cisco 7100 Series VPN Routers*
 - *Regulatory Compliance and Safety Information for Cisco 7200 Series Routers*
 - *Regulatory Compliance and Safety Information for Cisco uBR7200 Series Universal Broadband Routers*
 - *Regulatory Compliance and Safety Information for Cisco 7300 Series Routers*
 - *Regulatory Compliance and Safety Information for the Cisco 7401ASR Router*
 - *Regulatory Compliance and Safety Information for the Cisco 7500 Series Routers*
- To view Cisco documentation or obtain general information about the documentation, refer to the following sources:
 - [Obtaining Documentation](#), page x.
 - [Obtaining Technical Assistance](#), page xi
 - [Obtaining Additional Publications and Information](#), page xiii
 - Customer service at 800 553-6387 or 408 526-7208. Customer service hours are 5:00 a.m. to 6:00 p.m. Pacific time, Monday through Friday (excluding Cisco-observed holidays).
 - *Cisco Information Packet* that shipped with your router or switch.

Obtaining Documentation

Cisco provides several ways to obtain documentation, technical assistance, and other technical resources. These sections explain how to obtain technical information from Cisco Systems.

Cisco.com

You can access the most current Cisco documentation on the World Wide Web at this URL:

<http://www.cisco.com/univercd/home/home.htm>

You can access the Cisco website at this URL:

<http://www.cisco.com>

International Cisco websites can be accessed from this URL:

http://www.cisco.com/public/countries_languages.shtml

Documentation CD-ROM

Cisco documentation and additional literature are available in a Cisco Documentation CD-ROM package, which may have shipped with your product. The Documentation CD-ROM is updated regularly and may be more current than printed documentation. The CD-ROM package is available as a single unit or through an annual or quarterly subscription.

Registered Cisco.com users can order a single Documentation CD-ROM (product number DOC-CONDOCCD=) through the Cisco Ordering tool:

http://www.cisco.com/en/US/partner/ordering/ordering_place_order_ordering_tool_launch.html

All users can order monthly or quarterly subscriptions through the online Subscription Store:

<http://www.cisco.com/go/subscription>

Ordering Documentation

You can find instructions for ordering documentation at this URL:

http://www.cisco.com/univercd/cc/td/doc/es_inpck/pdi.htm

You can order Cisco documentation in these ways:

- Registered Cisco.com users (Cisco direct customers) can order Cisco product documentation from the Networking Products MarketPlace:

<http://www.cisco.com/en/US/partner/ordering/index.shtml>

- Nonregistered Cisco.com users can order documentation through a local account representative by calling Cisco Systems Corporate Headquarters (California, U.S.A.) at 408 526-7208 or, elsewhere in North America, by calling 800 553-NETS (6387).

Documentation Feedback

You can submit comments electronically on Cisco.com. On the Cisco Documentation home page, click **Feedback** at the top of the page.

You can e-mail your comments to bug-doc@cisco.com.

You can submit comments by using the response card (if present) behind the front cover of your document or by writing to the following address:

Cisco Systems
Attn: Customer Document Ordering
170 West Tasman Drive
San Jose, CA 95134-9883

We appreciate your comments.

Obtaining Technical Assistance

Cisco provides Cisco.com, which includes the Cisco Technical Assistance Center (TAC) website, as a starting point for all technical assistance. Customers and partners can obtain online documentation, troubleshooting tips, and sample configurations from the Cisco TAC website. Cisco.com registered users have complete access to the technical support resources on the Cisco TAC website, including TAC tools and utilities.

Cisco.com

Cisco.com offers a suite of interactive, networked services that let you access Cisco information, networking solutions, services, programs, and resources at any time, from anywhere in the world.

Cisco.com provides a broad range of features and services to help you with these tasks:

- Streamline business processes and improve productivity
- Resolve technical issues with online support
- Download and test software packages
- Order Cisco learning materials and merchandise
- Register for online skill assessment, training, and certification programs

To obtain customized information and service, you can self-register on Cisco.com at this URL:

<http://tools.cisco.com/RPF/register/register.do>

Technical Assistance Center

The Cisco TAC is available to all customers who need technical assistance with a Cisco product, technology, or solution. Two types of support are available: the Cisco TAC website and the Cisco TAC Escalation Center. The type of support that you choose depends on the priority of the problem and the conditions stated in service contracts, when applicable.

We categorize Cisco TAC inquiries according to urgency:

- Priority level 4 (P4)—You need information or assistance concerning Cisco product capabilities, product installation, or basic product configuration. There is little or no impact to your business operations.
- Priority level 3 (P3)—Operational performance of the network is impaired, but most business operations remain functional. You and Cisco are willing to commit resources during normal business hours to restore service to satisfactory levels.
- Priority level 2 (P2)—Operation of an existing network is severely degraded, or significant aspects of your business operations are negatively impacted by inadequate performance of Cisco products. You and Cisco will commit full-time resources during normal business hours to resolve the situation.
- Priority level 1 (P1)—An existing network is “down,” or there is a critical impact to your business operations. You and Cisco will commit all necessary resources around the clock to resolve the situation.

Cisco TAC Website

The Cisco TAC website provides online documents and tools to help troubleshoot and resolve technical issues with Cisco products and technologies. To access the Cisco TAC website, go to this URL:

<http://www.cisco.com/tac>

All customers, partners, and resellers who have a valid Cisco service contract have complete access to the technical support resources on the Cisco TAC website. Some services on the Cisco TAC website require a Cisco.com login ID and password. If you have a valid service contract but do not have a login ID or password, go to this URL to register:

<http://tools.cisco.com/RPF/register/register.do>

If you are a Cisco.com registered user, and you cannot resolve your technical issues by using the Cisco TAC website, you can open a case online at this URL:

<http://www.cisco.com/tac/caseopen>

If you have Internet access, we recommend that you open P3 and P4 cases online so that you can fully describe the situation and attach any necessary files.

If you have Internet access, we recommend that you open P3 and P4 cases through the Cisco TAC website so that you can describe the situation in your own words and attach any necessary files.

Cisco TAC Escalation Center

The Cisco TAC website provides online documents and tools to help troubleshoot and resolve technical issues with Cisco products and technologies. To access the Cisco TAC website, go to this URL:

<http://www.cisco.com/tac>

All customers, partners, and resellers who have a valid Cisco service contract have complete access to the technical support resources on the Cisco TAC website. Some services on the Cisco TAC website require a Cisco.com login ID and password. If you have a valid service contract but do not have a login ID or password, go to this URL to register:

<http://tools.cisco.com/RPF/register/register.do>

If you are a Cisco.com registered user, and you cannot resolve your technical issues by using the Cisco TAC website, you can open a case online at this URL:

<http://www.cisco.com/tac/caseopen>

If you have Internet access, we recommend that you open P3 and P4 cases online so that you can fully describe the situation and attach any necessary files.

Obtaining Additional Publications and Information

Information about Cisco products, technologies, and network solutions is available from various online and printed sources.

- The *Cisco Product Catalog* describes the networking products offered by Cisco Systems, as well as ordering and customer support services. Access the *Cisco Product Catalog* at this URL:

http://www.cisco.com/en/US/products/products_catalog_links_launch.html

- Cisco Press publishes a wide range of networking publications. Cisco suggests these titles for new and experienced users: *Internetworking Terms and Acronyms Dictionary*, *Internetworking Technology Handbook*, *Internetworking Troubleshooting Guide*, and the *Internetworking Design Guide*. For current Cisco Press titles and other information, go to Cisco Press online at this URL:

<http://www.ciscopress.com>

- *Packet* magazine is the Cisco quarterly publication that provides the latest networking trends, technology breakthroughs, and Cisco products and solutions to help industry professionals get the most from their networking investment. Included are networking deployment and troubleshooting tips, configuration examples, customer case studies, tutorials and training, certification information, and links to numerous in-depth online resources. You can access *Packet* magazine at this URL:

<http://www.cisco.com/go/packet>

- iQ Magazine is the Cisco bimonthly publication that delivers the latest information about Internet business strategies for executives. You can access iQ Magazine at this URL:

<http://www.cisco.com/go/iqmagazine>

- Internet Protocol Journal is a quarterly journal published by Cisco Systems for engineering professionals involved in designing, developing, and operating public and private internets and intranets. You can access the Internet Protocol Journal at this URL:

http://www.cisco.com/en/US/about/ac123/ac147/about_cisco_the_internet_protocol_journal.html

- Training—Cisco offers world-class networking training. Current offerings in network training are listed at this URL:

http://www.cisco.com/en/US/learning/le31/learning_recommended_training_list.html



Overview

This chapter describes the Cisco PA-8T-X21 synchronous serial port adapter. This chapter contains the following sections:

- [Port Adapter Overview, page 1-1](#)
- [Serial Interface Specifications, page 1-2](#)
- [LEDs, page 1-3](#)
- [Cables and Pinouts, page 1-4](#)
- [Port Adapter Slot Locations on the Supported Platforms, page 1-15](#)
- [Identifying Interface Addresses, page 1-23](#)

Port Adapter Overview

The PA-8T-X21 synchronous serial port adapter, shown in [Figure 1-1](#), provides up to eight synchronous serial interfaces for the Cisco 7000 family routers and the Cisco uBR7200 series routers. PA-8T-X21 network interfaces provide a direct connection between the high-speed bus in the router and external networks. Each PA-8T-X21 interface provides full-duplex (FDX) operation at T1 (1.544 Mbps) and E1 (2.048 Mbps) speeds. The X.21 interface is commonly used in the United Kingdom to connect to public data networks.

All eight PA-8T-X21 interfaces connect to external networks through a single port that has a 200-pin, D-shell receptacle. You must use an X.21 compact serial cable to connect PA-8T-X21 interfaces to an external data service unit (DSU) or channel service unit (CSU). The compact serial cable attached to the single receptacle determines the mode (DCE or DTE) for all eight interfaces.



Note

Although the Cisco 7304 PCI Port Adapter Carrier Card in the Cisco 7304 router, Catalyst RSM/VIP2, the Catalyst 6000 family FlexWAN module, and the VIP support online insertion and removal (OIR), individual port adapters do not. To replace port adapters, you must first remove the Cisco 7304 PCI Port Adapter Carrier Card in the Cisco 7304 router, the Catalyst RSM/VIP2, the Catalyst 6000 family FlexWAN module, or the VIP from the chassis, and then replace port adapters as required.

The Cisco 7100 series, Cisco 7200 series, Cisco uBR7200 series routers, Cisco 7301 router, and Cisco 7401ASR routers support the OIR of all port adapter types.

Figure 1-1 PA-8T-X21—Faceplate View

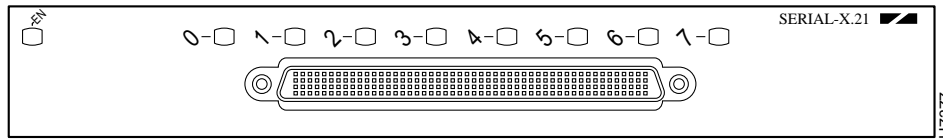

All serial interface types of Cisco 7200 series, Cisco uBR7200 series, Cisco 7100 series, Cisco 7301 routers, Cisco 7304 routers, Cisco 7401ASR routers, VIPs, and Catalyst RSM/VIP2s support non return to zero (NRZ) and non return to zero inverted (NRZI) format, and both 16-bit and 32-bit cyclic redundancy checks (CRCs). The default configuration is for NRZ format and 16-bit CRC. You can change the default settings with software commands. (For more information, see [Chapter 5, “Configuring the PA-8T-X21 Interfaces”](#).)

No default mode or clock rate are set on the serial ports of Cisco 7200 series, Cisco uBR7200 series, Cisco 7100 series, Cisco 7301 routers, Cisco 7304 routers, Cisco 7401ASR routers, VIPs, and Catalyst RSM/VIP2s, although an internal clock signal is present on all ports for data communications equipment (DCE) support. The internal clock also allows you to perform local loopback tests without having to terminate the port or connect a cable. To use the port as a DCE interface, you must set the clock rate and connect a DCE compact serial cable. To use the port as a data terminal equipment (DTE) interface, you need only connect a DTE compact serial cable to the port. Because the serial adapter cables determine the mode and interface type, the PA-8T-X21 port adapter interface becomes a DTE when a DTE cable is connected to it.

If a DTE cable is connected to a port with a clock rate set, the DTE ignores the clock rate and uses the external clock signal that is sent from the remote DCE. For a brief description of the **clock rate** command, see the [“Configuring Timing \(Clock\) Signals”](#) section on page 5-10. For complete command descriptions and instructions, refer to the publications listed in the [“Related Documentation”](#) section on page viii.

Serial Interface Specifications

Serial signals can travel a limited distance at any given bit rate; generally, the slower the bit rate, the greater the distance. All serial signals are subject to distance limits beyond which a signal degrades significantly or is completely lost. [Table 1-1](#) lists recommended transmission speeds and distances for X.21 serial interfaces. The recommended maximum rate for X.21 is 2.048 Mbps.

Table 1-1 Recommended Transmission Speed Versus Distance

Rate (bps)	X.21 Distances	
	Feet	Meters
2400	4,100	1,250
4800	2,050	625
9600	1,025	312
19200	513	156
38400	256	78
56000	102	31
2048000	25	8

**Note**

X.21 supports 2.048-Mbps rates without any problems; we do not recommend exceeding the above specifications for transmission speed versus distance. Do so at your own risk. The total aggregate bandwidth for the PA-8T-X21 is 16 Mbps, which can be divided into 8 Mbps on two ports, 4 Mbps on four ports, or 2 Mbps on eight ports.

The PA-8T-X21 can be installed in the following slots on the hardware platforms described in this document:

- Catalyst RSM/VIP2—Port adapter slot 0 and port adapter slot 1
- Catalyst 6000 family FlexWAN module—Port adapter bay 0 and port adapter bay 1
- Cisco 7100 series—Port adapter slot 3 of the Cisco 7120 series, and port adapter slot 4 of the Cisco 7140 series
- Cisco 7200 series routers—Port adapter slot 1 and slot 2 of the Cisco 7202; port adapter slot 1 through slot 4 of the Cisco 7204 and Cisco 7204VXR; port adapter slot 1 through slot 6 of the Cisco 7206 and Cisco 7206VXR
- Cisco uBR7200 series—Port adapter slot 1 and port adapter slot 2 of the Cisco uBR7246 and port adapter slot 1 of the Cisco uBR7223
- Cisco 7301—Port adapter slot 1
- Cisco 7304 PCI Port Adapter Carrier Card in the Cisco 7304 router — Port adapter slot 2 through 5
- Cisco 7401ASR routers—Port adapter slot 1
- VIP—Port adapter slot 0 and port adapter slot 1

Port adapters have a handle attached, but this handle is occasionally not shown in this document to allow a full view of the port adapter's faceplate.

LEDs

The PA-8T-X21 has one row of eight status LEDs (one for each port) and one enabled (EN) LED. (See [Figure 1-2](#).) The green- and amber-colored LED for each port indicates port status.

Figure 1-2 LEDs on the PA-8T-X21—Horizontal Orientation

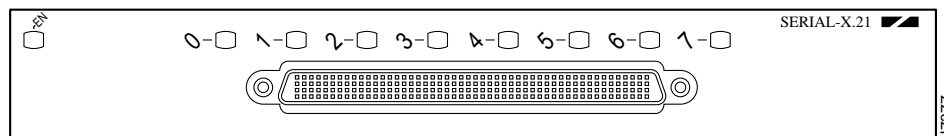

After system initialization, the enabled LED goes on to indicate that the port adapter has been enabled for operation.

The following conditions must be met before the PA-8T-X21 is enabled:

- Port adapter is correctly connected to the backplane or midplane and receiving power.
- Valid system software image for the port adapter has been downloaded successfully.
- System recognizes the port adapter or PA-8T-X21-equipped Catalyst RSM/VIP2, Catalyst 6000 family FlexWAN module, VIP, or Cisco 7304 PCI Port Adapter Carrier Card.

If any of the above conditions are not met, or if the initialization fails for other reasons, the enabled LED does not go on.

Table 1-2 lists port LED colors and status.

Table 1-2 PA-8T-X21 Port LED Indications

Port LED	Color	Status
0 through 7	Green	Port is initialized by the system (the software recognizes the hardware), and an X.21 compact serial cable is properly connected at the router end (VIP, Catalyst RSM/VIP2, Cisco 7200 series, Cisco uBR7200 series, Cisco 7100 series, Cisco 7301 routers, or Cisco 7401ASR routers) and the network end. The LED flashes on and off when the port is sending and receiving data in half-duplex mode (in Cisco 7200 series routers only).
	Amber	Port is in loopback mode, the compact serial cable is not properly connected at the router or network end, or there is a problem with the hardware at the network end of the compact serial cable.
	Off	Port is administratively down.

Cables and Pinouts

The compact serial cable for the PA-8T-X21 is available in DTE or DCE mode with a 200-pin, D-shell receptacle at the router end (Catalyst RSM/VIP2, Catalyst 6000 family FlexWAN module, Cisco 7200 series, Cisco 7301 routers, Cisco 7401ASR routers, or VIP) and eight, 15-pin Winchester block-type receptacles or plugs at the network end. (See [Figure 1-3 on page 1-5](#).) The compact serial cable for the PA-8T-X21 is 6 feet (1.8 meters) long.



Note

The X.21 compact serial cable attached to the single PA-8T-X21 port determines the mode (DTE or DCE) of the eight PA-8T-X21 interfaces.

Following are the product numbers, according to mode, for the PA-8T-X21 compact serial cable:

- DTE mode with a 15-pin Winchester-type X.21 plug (CAB-OCT-X21-MT[=])
- DCE mode with a 15-pin Winchester-type X.21 receptacle (CAB-OCT-X21-FC[=])

Figure 1-3 X.21 Compact Serial Cable

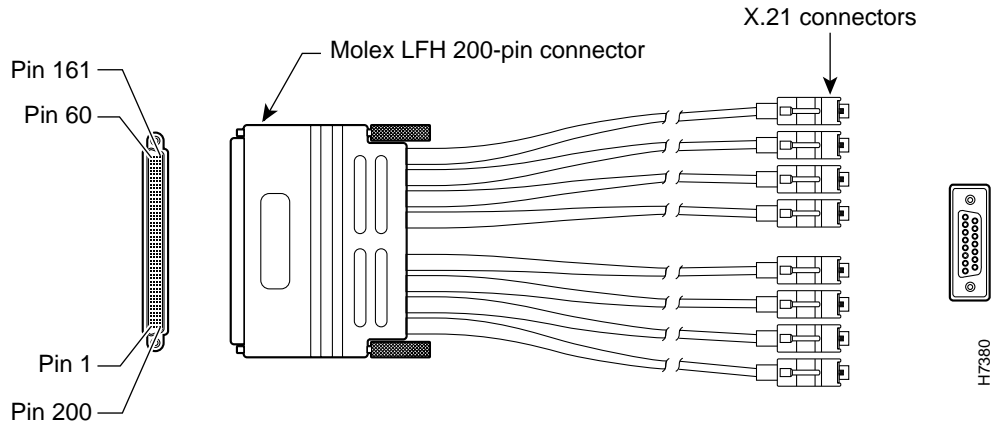

Because the PA-8T-X21 uses a special, high-density port that requires special compact serial interface cables, we recommend that you obtain the cables from the factory. Figure 1-4 shows the connectors at the network end of the PA-8T-X21 compact serial cable.

Figure 1-4 PA-8T-X21 Compact Serial Cable Connectors

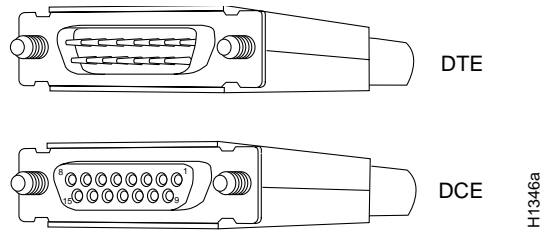

Table 1-3 lists connector pinouts for the PA-8T-X21 DTE compact serial cable (CAB-OCT-X21-MT[=]), and Table 1-4 lists connector pinouts for the PA-8T-X21 DCE compact serial cable (CAB-OCT-X21-FC[=]).

Table 1-3 PA-8T-X21 DTE Compact Serial Cable Pinouts

Router End (200-Position Plug)				Network End (15-Pin Connector)	
Pin	Signal	Note	Direction	Signal	Pin
J8-75	MODE_2	Shorting	—		
J8-76	GROUND	Group			
J8-26	MODE_DCE	Shorting			
J8-25	GROUND	Group			
	SHIELD_GROUND	Braid		SHIELD GND	J0-1
J8-1	O_TXD/RXD+	Twisted pair no. 1	—>	TRANSMIT+	J0-2
J8-2	O_TXD/RXD-		—>	TRANSMIT-	J0-9
J8-16	O_RTS/CTS+	Twisted pair no. 4	—>	CONTROL+	J0-3
J8-17	O_RTS/CTS-		—>	CONTROL-	J0-10

Table 1-3 PA-8T-X21 DTE Compact Serial Cable Pinouts (continued)

Router End (200-Position Plug)				Network End (15-Pin Connector)	
Pin	Signal	Note	Direction	Signal	Pin
J8-5	I_RXD/TXD+	Twisted pair no. 2	<—	RECEIVE+	J0-4
J8-6	I_RXD/TXD-		<—	RECEIVE-	J0-11
J8-23	I_CTS/RTS+	Twisted pair no. 5	<—	INDICATION+	J0-5
J8-24	I_CTS/RTS-		<—	INDICATION-	J0-12
J8-7	I_RXC/TXCE+	Twisted pair no. 3	<—	TIMING+	J0-6
J8-8	I_RXC/TXCE-		<—	TIMING-	J0-13
J8-11	SIG_GROUND	Twisted pair no. 6	—	SIG GND	J0-8
J8-18	SIG_GROUND		—	SIG GND	J0-8
—	Not used Not used	Twisted pair no. 7	—	Not used Not used	—
—	Not used Not used		Twisted pair no. 8	—	Not used Not used
—	Not used Not used	Twisted pair no. 9		—	Not used Not used
	SHIELD_GROUND		Braid		SHIELD GND
J8-50	O_TXD/RXD+	Twisted pair no. 1	—>	TRANSMIT+	J1-2
J8-49	O_TXD/RXD-		—>	TRANSMIT-	J1-9
J8-35	O_RTS/CTS+	Twisted pair no. 4	—>	CONTROL+	J1-3
J8-34	O_RTS/CTS-		—>	CONTROL-	J1-10
J8-46	I_RXD/TXD+	Twisted pair no. 2	<—	RECEIVE+	J1-4
J8-45	I_RXD/TXD-		<—	RECEIVE-	J1-11
J8-28	I_CTS/RTS+	Twisted pair no. 5	<—	INDICATION+	J1-5
J8-27	I_CTS/RTS-		<—	INDICATION-	J1-12
J8-44	I_RXC/TXCE+	Twisted pair no. 3	<—	TIMING+	J1-6
J8-43	I_RXC/TXCE-		<—	TIMING-	J1-13
J8-40	SIG_GROUND	Twisted pair no. 6	—	SIG GND	J1-8
J8-33	SIG_GROUND		—	SIG GND	J1-8
—	Not used Not used	Twisted pair no. 7	—	Not used Not used	—
—	Not used Not used		Twisted pair no. 8	—	Not used Not used
—	Not used Not used	Twisted pair no. 9		—	Not used Not used
	SHIELD_GROUND		Braid		SHIELD GND

Table 1-3 PA-8T-X21 DTE Compact Serial Cable Pinouts (continued)

Router End (200-Position Plug)				Network End (15-Pin Connector)	
Pin	Signal	Note	Direction	Signal	Pin
J8-51	O_TXD/RXD+	Twisted pair no. 1	—>	TRANSMIT+	J2-2
J8-52	O_TXD/RXD-		—>	TRANSMIT-	J2-9
J8-66	O_RTS/CTS+	Twisted pair no. 4	—>	CONTROL+	J2-3
J8-67	O_RTS/CTS-		—>	CONTROL-	J2-10
J8-55	I_RXD/TXD+	Twisted pair no. 2	<—	RECEIVE+	J2-4
J8-56	I_RXD/TXD-		<—	RECEIVE-	J2-11
J8-73	I_CTS/RTS+	Twisted pair no. 5	<—	INDICATION+	J2-5
J8-74	I_CTS/RTS-		<—	INDICATION-	J2-12
J8-57	I_RXC/TXCE+	Twisted pair no. 3	<—	TIMING+	J2-6
J8-58	I_RXC/TXCE-		<—	TIMING-	J2-13
J8-61	SIG_GROUND	Twisted pair no. 6	-	SIG GND	J2-8
J8-68	SIG_GROUND			SIG GND	J2-8
-	Not used	Twisted pair no. 7	-	Not used	-
	Not used			Not used	
-	Not used	Twisted pair no. 8	-	Not used	-
	Not used			Not used	
-	Not used	Twisted pair no. 9	-	Not used	-
	Not used			Not used	
	SHIELD_GROUND	Braid		SHIELD GND	J3-1
J8-100	O_TXD/RXD+	Twisted pair no. 1	—>	TRANSMIT+	J3-2
J8-99	O_TXD/RXD-		—>	TRANSMIT-	J3-9
J8-85	O_RTS/CTS+	Twisted pair no. 4	—>	CONTROL+	J3-3
J8-84	O_RTS/CTS-		—>	CONTROL-	J3-10
J8-96	I_RXD/TXD+	Twisted pair no. 2	<—	RECEIVE+	J3-4
J8-95	I_RXD/TXD-		<—	RECEIVE-	J3-11
J8-78	I_CTS/RTS+	Twisted pair no. 5	<—	INDICATION+	J3-5
J8-77	I_CTS/RTS-		<—	INDICATION-	J3-12
J8-94	I_RXC/TXCE+	Twisted pair no. 3	<—	TIMING+	J3-6
J8-93	I_RXC/TXCE-		<—	TIMING-	J3-13
J8-90	SIG_GROUND	Twisted pair no. 6	-	SIG GND	J3-8
J8-83	SIG_GROUND			SIG GND	J3-8
-	Not used	Twisted pair no. 7	-	Not used	-
	Not used			Not used	
-	Not used	Twisted pair no. 8	-	Not used	-
	Not used			Not used	

Table 1-3 PA-8T-X21 DTE Compact Serial Cable Pinouts (continued)

Router End (200-Position Plug)				Network End (15-Pin Connector)	
Pin	Signal	Note	Direction	Signal	Pin
–	Not used Not used	Twisted pair no. 9	–	Not used Not used	–
	SHIELD_GROUND	Braid		SHIELD GND	J4-1
J8-101	O_TXD/RXD+	Twisted pair no. 1	—>	TRANSMIT+	J4-2
J8-102	O_TXD/RXD–		—>	TRANSMIT–	J4-9
J8-116	O_RTS/CTS+	Twisted pair no. 4	—>	CONTROL+	J4-3
J8-117	O_RTS/CTS–		—>	CONTROL–	J4-10
J8-105	I_RXD/TXD+	Twisted pair no. 2	<—	RECEIVE+	J4-4
J8-106	I_RXD/TXD–		<—	RECEIVE–	J4-11
J8-123	I_CTS/RTS+	Twisted pair no. 5	<—	INDICATION+	J4-5
J8-124	I_CTS/RTS–		<—	INDICATION–	J4-12
J8-107	I_RXC/TXCE+	Twisted pair no. 3	<—	TIMING+	J4-6
J8-108	I_RXC/TXCE–		<—	TIMING–	J4-13
J8-111	SIG_GROUND	Twisted pair no. 6	–	SIG GND	J4-8
J8-118	SIG_GROUND			SIG GND	J4-8
–	Not used Not used	Twisted pair no. 7	–	Not used Not used	–
–	Not used Not used	Twisted pair no. 8	–	Not used Not used	–
–	Not used Not used	Twisted pair no. 9	–	Not used Not used	–
	SHIELD_GROUND	Braid		SHIELD GND	J5-1
J8-150	O_TXD/RXD+	Twisted pair no. 1	—>	TRANSMIT+	J5-2
J8-149	O_TXD/RXD–		—>	TRANSMIT–	J5-9
J8-135	O_RTS/CTS+	Twisted pair no. 4	—>	CONTROL+	J5-3
J8-134	O_RTS/CTS–		—>	CONTROL–	J5-10
J8-146	I_RXD/TXD+	Twisted pair no. 2	<—	RECEIVE+	J5-4
J8-145	I_RXD/TXD–		<—	RECEIVE–	J5-11
J8-128	I_CTS/RTS+	Twisted pair no. 5	<—	INDICATION+	J5-5
J8-127	I_CTS/RTS–		<—	INDICATION–	J5-12
J8-144	I_RXC/TXCE+	Twisted pair no. 3	<—	TIMING+	J5-6
J8-143	I_RXC/TXCE–		<—	TIMING–	J5-13
J8-140	SIG_GROUND	Twisted pair no. 6	–	SIG GND	J5-8
J8-133	SIG_GROUND			SIG GND	J5-8

Table 1-3 PA-8T-X21 DTE Compact Serial Cable Pinouts (continued)

Router End (200-Position Plug)				Network End (15-Pin Connector)	
Pin	Signal	Note	Direction	Signal	Pin
–	Not used Not used	Twisted pair no. 7	–	Not used Not used	–
–	Not used Not used	Twisted pair no. 8	–	Not used Not used	–
–	Not used Not used	Twisted pair no. 9	–	Not used Not used	–
	SHIELD_GROUND	Braid		SHIELD GND	J6-1
J8-151	O_TXD/RXD+	Twisted pair no. 1	—>	TRANSMIT+	J6-2
J8-152	O_TXD/RXD–		—>	TRANSMIT–	J6-9
J8-166	O_RTS/CTS+	Twisted pair no. 4	—>	CONTROL+	J6-3
J8-167	O_RTS/CTS–		—>	CONTROL–	J6-10
J8-155	I_RXD/TXD+	Twisted pair no. 2	<—	RECEIVE+	J6-4
J8-156	I_RXD/TXD–		<—	RECEIVE–	J6-11
J8-173	I_CTS/RTS+	Twisted pair no. 5	<—	INDICATION+	J6-5
J8-174	I_CTS/RTS–		<—	INDICATION–	J6-12
J8-157	I_RXC/TXCE+	Twisted pair no. 3	<—	TIMING+	J6-6
J8-158	I_RXC/TXCE–		<—	TIMING–	J6-13
J8-161	SIG_GROUND	Twisted pair no. 6	–	SIG GND	J6-8
J8-168	SIG_GROUND			SIG GND	J6-8
–	Not used Not used	Twisted pair no. 7	–	Not used Not used	–
–	Not used Not used	Twisted pair no. 8	–	Not used Not used	–
–	Not used Not used	Twisted pair no. 9	–	Not used Not used	–
	SHIELD_GROUND	Braid		SHIELD GND	J7-1
J8-200	O_TXD/RXD+	Twisted pair no. 1	—>	TRANSMIT+	J7-2
J8-199	O_TXD/RXD–		—>	TRANSMIT–	J7-9
J8-185	O_RTS/CTS+	Twisted pair no. 4	—>	CONTROL+	J7-3
J8-184	O_RTS/CTS–		—>	CONTROL–	J7-10
J8-196	I_RXD/TXD+	Twisted pair no. 2	<—	RECEIVE+	J7-4
J8-195	I_RXD/TXD–		<—	RECEIVE–	J7-11
J8-178	I_CTS/RTS+	Twisted pair no. 5	<—	INDICATION+	J7-5
J8-177	I_CTS/RTS–		<—	INDICATION–	J7-12

Table 1-3 PA-8T-X21 DTE Compact Serial Cable Pinouts (continued)

Router End (200-Position Plug)				Network End (15-Pin Connector)	
Pin	Signal	Note	Direction	Signal	Pin
J8-194	I_RXC/TXCE+	Twisted pair no. 3	<—	TIMING+	J7-6
J8-193	I_RXC/TXCE-		<—	TIMING-	J7-13
J8-190	SIG_GROUND	Twisted pair no. 6	—	SIG GND	J7-8
J8-183	SIG_GROUND		—	SIG GND	J7-8
—	Not used	Twisted pair no. 7	—	Not used	—
—	Not used		—	Not used	—
—	Not used	Twisted pair no. 8	—	Not used	—
—	Not used		—	Not used	—
—	Not used	Twisted pair no. 9	—	Not used	—
—	Not used		—	Not used	—

Table 1-4 PA-8T-X21 DCE Compact Serial Cable Pinouts

Router End (200-Position Plug)				Network End (15-Pin Connector)	
Pin	Signal	Note	Direction	Signal	Pin
J8-75	MODE_2	Shorting Group	—		
J8-76	GROUND		—		
	SHIELD_GROUND	Braid		SHIELD GND	J0-1
J8-5	I_RXD/TXD+	Twisted pair no. 1	<—	TRANSMIT+	J0-2
J8-6	I_RXD/TXD-		<—	TRANSMIT-	J0-9
J8-23	I_CTS/RTS+	Twisted pair no. 4	<—	CONTROL+	J0-3
J8-24	I_CTS/RTS-		<—	CONTROL-	J0-10
J8-1	O_TXD/RXD+	Twisted pair no. 2	—>	RECEIVE+	J0-4
J8-2	O_TXD/RXD-		—>	RECEIVE-	J0-11
J8-16	O_RTS/CTS+	Twisted pair no. 5	—>	INDICATION+	J0-5
J8-17	O_RTS/CTS-		—>	INDICATION-	J0-12
J8-3	O_TXCE/RXC+	Twisted pair no. 3	—>	TIMING+	J0-6
J8-4	O_TXCE/RXC-		—>	TIMING-	J0-13
J8-11	SIG_GROUND	Twisted pair no. 6	—	SIG GND	J0-8
J8-18	SIG_GROUND		—	SIG GND	J0-8
—	Not used	Twisted pair no. 7	—	Not used	—
—	Not used		—	Not used	—
—	Not used	Twisted pair no. 8	—	Not used	—
—	Not used		—	Not used	—

Table 1-4 PA-8T-X21 DCE Compact Serial Cable Pinouts (continued)

Router End (200-Position Plug)				Network End (15-Pin Connector)	
Pin	Signal	Note	Direction	Signal	Pin
–	Not used Not used	Twisted pair no. 9	–	Not used Not used	–
	SHIELD_GROUND	Braid		SHIELD GND	J1-1
J8-46	I_RXD/TXD+	Twisted pair no. 1	<—	TRANSMIT+	J1-2
J8-45	I_RXD/TXD–		<—	TRANSMIT–	J1-9
J8-28	I_CTS/RTS+	Twisted pair no. 4	<—	CONTROL+	J1-3
J8-27	I_CTS/RTS–		<—	CONTROL–	J1-10
J8-50	O_TXD/RXD+	Twisted pair no. 2	—>	RECEIVE+	J1-4
J8-49	O_TXD/RXD–		—>	RECEIVE–	J1-11
J8-35	O_RTS/CTS+	Twisted pair no. 5	—>	INDICATION+	J1-5
J8-34	O_RTS/CTS–		—>	INDICATION–	J1-12
J8-48	O_TXCE/RXC+	Twisted pair no. 3	—>	TIMING+	J1-6
J8-47	O_TXCE/RXC–		—>	TIMING–	J1-13
J8-40	SIG_GROUND	Twisted pair no. 6	–	SIG GND	J1-8
J8-33	SIG_GROUND			SIG GND	J1-8
–	Not used Not used	Twisted pair no. 7	–	Not used Not used	–
–	Not used Not used	Twisted pair no. 8	–	Not used Not used	–
–	Not used Not used	Twisted pair no. 9	–	Not used Not used	–
	SHIELD_GROUND	Braid		SHIELD GND	J2-1
J8-55	I_RXD/TXD+	Twisted pair no. 1	<—	TRANSMIT+	J2-2
J8-56	I_RXD/TXD–		<—	TRANSMIT–	J2-9
J8-73	I_CTS/RTS+	Twisted pair no. 4	<—	CONTROL+	J2-3
J8-74	I_CTS/RTS–		<—	CONTROL–	J2-10
J8-51	O_TXD/RXD+	Twisted pair no. 2	—>	RECEIVE+	J2-4
J8-52	O_TXD/RXD–		—>	RECEIVE–	J2-11
J8-66	O_RTS/CTS+	Twisted pair no. 5	—>	INDICATION+	J2-5
J8-67	O_RTS/CTS–		—>	INDICATION–	J2-12
J8-53	O_TXCE/RXC+	Twisted pair no. 3	—>	TIMING+	J2-6
J8-54	O_TXCE/RXC–		—>	TIMING–	J2-13
J8-61	SIG_GROUND	Twisted pair no. 6	–	SIG GND	J2-8
J8-68	SIG_GROUND			SIG GND	J2-8

Table 1-4 PA-8T-X21 DCE Compact Serial Cable Pinouts (continued)

Router End (200-Position Plug)				Network End (15-Pin Connector)	
Pin	Signal	Note	Direction	Signal	Pin
–	Not used Not used	Twisted pair no. 7	–	Not used Not used	–
–	Not used Not used	Twisted pair no. 8	–	Not used Not used	–
–	Not used Not used	Twisted pair no. 9	–	Not used Not used	–
	SHIELD_GROUND	Braid		SHIELD GND	J3-1
J8-96	I_RXD/TXD+	Twisted pair no. 1	<—	TRANSMIT+	J3-2
J8-95	I_RXD/TXD–		<—	TRANSMIT–	J3-9
J8-78	I_CTS/RTS+	Twisted pair no. 4	<—	CONTROL+	J3-3
J8-77	I_CTS/RTS–		<—	CONTROL–	J3-10
J8-100	O_TXD/RXD+	Twisted pair no. 2	—>	RECEIVE+	J3-4
J8-99	O_TXD/RXD–		—>	RECEIVE–	J3-11
J8-85	O_RTS/CTS+	Twisted pair no. 5	—>	INDICATION+	J3-5
J8-84	O_RTS/CTS–		—>	INDICATION–	J3-12
J8-98	O_TXCE/RXC+	Twisted pair no. 3	—>	TIMING+	J3-6
J8-97	O_TXCE/RXC–		—>	TIMING–	J3-13
J8-90	SIG_GROUND	Twisted pair no. 6	–	SIG GND	J3-8
J8-83	SIG_GROUND			SIG GND	J3-8
–	Not used Not used	Twisted pair no. 7	–	Not used Not used	–
–	Not used Not used	Twisted pair no. 8	–	Not used Not used	–
–	Not used Not used	Twisted pair no. 9	–	Not used Not used	–
	SHIELD_GROUND	Braid		SHIELD GND	J4-1
J8-105	I_RXD/TXD+	Twisted pair no. 1	<—	TRANSMIT+	J4-2
J8-106	I_RXD/TXD–		<—	TRANSMIT–	J4-9
J8-123	I_CTS/RTS+	Twisted pair no. 4	<—	CONTROL+	J4-3
J8-124	I_CTS/RTS–		<—	CONTROL–	J4-10
J8-101	O_TXD/RXD+	Twisted pair no. 2	—>	RECEIVE+	J4-4
J8-102	O_TXD/RXD–		—>	RECEIVE–	J4-11
J8-116	O_RTS/CTS+	Twisted pair no. 5	—>	INDICATION+	J4-5
J8-117	O_RTS/CTS–		—>	INDICATION–	J4-12

Table 1-4 PA-8T-X21 DCE Compact Serial Cable Pinouts (continued)

Router End (200-Position Plug)				Network End (15-Pin Connector)	
Pin	Signal	Note	Direction	Signal	Pin
J8-103	O_TXCE/RXC+	Twisted pair no. 3	—>	TIMING+	J4-6
J8-104	O_TXCE/RXC-		—>	TIMING-	J4-13
J8-111	SIG_GROUND	Twisted pair no. 6	-	SIG GND	J4-8
J8-118	SIG_GROUND			SIG GND	J4-8
-	Not used	Twisted pair no. 7	-	Not used	-
	Not used			Not used	
-	Not used	Twisted pair no. 8	-	Not used	-
	Not used			Not used	
-	Not used	Twisted pair no. 9	-	Not used	-
	Not used			Not used	
	SHIELD_GROUND	Braid		SHIELD GND	J5-1
J8-146	I_RXD/TXD+	Twisted pair no. 1	<—	TRANSMIT+	J5-2
J8-145	I_RXD/TXD-		<—	TRANSMIT-	J5-9
J8-128	I_CTS/RTS+	Twisted pair no. 4	<—	CONTROL+	J5-3
J8-127	I_CTS/RTS-		<—	CONTROL-	J5-10
J8-150	O_TXD/RXD+	Twisted pair no. 2	—>	RECEIVE+	J5-4
J8-149	O_TXD/RXD-		—>	RECEIVE-	J5-11
J8-135	O_RTS/CTS+	Twisted pair no. 5	—>	INDICATION+	J5-5
J8-134	O_RTS/CTS-		—>	INDICATION-	J5-12
J8-148	O_TXCE/RXC+	Twisted pair no. 3	—>	TIMING+	J5-6
J8-147	O_TXCE/RXC-		—>	TIMING-	J5-13
J8-140	SIG_GROUND	Twisted pair no. 6	-	SIG GND	J5-8
J8-133	SIG_GROUND			SIG GND	J5-8
-	Not used	Twisted pair no. 7	-	Not used	-
	Not used			Not used	
-	Not used	Twisted pair no. 8	-	Not used	-
	Not used			Not used	
-	Not used	Twisted pair no. 9	-	Not used	-
	Not used			Not used	
	SHIELD_GROUND	Braid		SHIELD GND	J6-1
J8-155	I_RXD/TXD+	Twisted pair no. 1	<—	TRANSMIT+	J6-2
J8-156	I_RXD/TXD-		<—	TRANSMIT-	J6-9
J8-173	I_CTS/RTS+	Twisted pair no. 4	<—	CONTROL+	J6-3
J8-174	I_CTS/RTS-		<—	CONTROL-	J6-10

Table 1-4 PA-8T-X21 DCE Compact Serial Cable Pinouts (continued)

Router End (200-Position Plug)				Network End (15-Pin Connector)	
Pin	Signal	Note	Direction	Signal	Pin
J8-151	O_TXD/RXD+	Twisted pair no. 2	—>	RECEIVE+	J6-4
J8-152	O_TXD/RXD-		—>	RECEIVE-	J6-11
J8-166	O_RT5/CTS+	Twisted pair no. 5	—>	INDICATION+	J6-5
J8-167	O_RT5/CTS-		—>	INDICATION-	J6-12
J8-153	O_TXCE/RXC+	Twisted pair no. 3	—>	TIMING+	J6-6
J8-154	O_TXCE/RXC-		—>	TIMING-	J6-13
J8-161	SIG_GROUND	Twisted pair no. 6	-	SIG GND	J6-8
J8-168	SIG_GROUND		SIG GND	J6-8	
-	Not used Not used	Twisted pair no. 7	-	Not used Not used	-
-	Not used Not used		Twisted pair no. 8	-	Not used Not used
-	Not used Not used	Twisted pair no. 9		-	Not used Not used
	SHIELD_GROUND		Braid		SHIELD GND
J8-196	I_RXD/TXD+	Twisted pair no. 1	<—	TRANSMIT+	J7-2
J8-195	I_RXD/TXD-		<—	TRANSMIT-	J7-9
J8-178	I_CTS/RTS+	Twisted pair no. 4	<—	CONTROL+	J7-3
J8-177	I_CTS/RTS-		<—	CONTROL-	J7-10
J8-200	O_TXD/RXD+	Twisted pair no. 2	—>	RECEIVE+	J7-4
J8-199	O_TXD/RXD-		—>	RECEIVE-	J7-11
J8-185	O_RT5/CTS+	Twisted pair no. 5	—>	INDICATION+	J7-5
J8-184	O_RT5/CTS-		—>	INDICATION-	J7-12
J8-198	O_TXCE/RXC+	Twisted pair no. 3	—>	TIMING+	J7-6
J8-197	O_TXCE/RXC-		—>	TIMING-	J7-13
J8-190	SIG_GROUND	Twisted pair no. 6	-	SIG GND	J7-8
J8-183	SIG_GROUND		SIG GND	J7-8	
-	Not used Not used	Twisted pair no. 7	-	Not used Not used	-
-	Not used Not used		Twisted pair no. 8	-	Not used Not used
-	Not used Not used	Twisted pair no. 9		-	Not used Not used

Port Adapter Slot Locations on the Supported Platforms

This section discusses port adapter slot locations on the supported platforms. The Illustrations that follow summarize slot locations on each platform:

- [Catalyst RSM/VIP2 Slot Numbering, page 1-15](#)
- [Catalyst 6000 Family FlexWAN Module Slot Numbering, page 1-16](#)
- [Cisco 7100 Series Routers Slot Numbering, page 1-18](#)
- [Cisco 7200 Series and Cisco uBR7200 Series Routers Slot Numbering, page 1-19](#)
- [Cisco 7301 Router Slot Numbering, page 1-20](#)
- [Cisco 7304 PCI Port Adapter Carrier Card Slot Numbering, page 1-20](#)
- [Cisco 7401ASR Router Slot Numbering, page 1-22](#)
- [VIP Slot Numbering, page 1-22](#)

Catalyst RSM/VIP2 Slot Numbering

The Catalyst RSM/VIP2 can be installed in any slot except the top slots, which contain the supervisor engines. The Catalyst RSM/VIP2 in a Catalyst 5000 family switch does not use interface processor slot numbering; therefore, slots are not numbered in [Figure 1-5](#). The PA-8T-X21 can be installed into either port adapter slot 0 or slot 1 on a Catalyst RSM/VIP2. [Figure 1-5](#) shows a Catalyst RSM/VIP2 with two port adapters installed.



Note

The Catalyst 5500 switch has 13 slots. Slot 1 is reserved for the supervisor engine. If a redundant supervisor engine is used, it would go in slot 2; otherwise, slot 2 can be used for other modules. Slot 13 is a dedicated slot, reserved for the ATM switch processor (ASP) module. Refer to the *Catalyst 5000 Series Route Switch Module Installation and Configuration Note* for any additional slot restrictions for the Catalyst RSM/VIP2.

Figure 1-5 Catalyst 5000 Family Switch with Port Adapters Installed on Catalyst RSM/VIP2

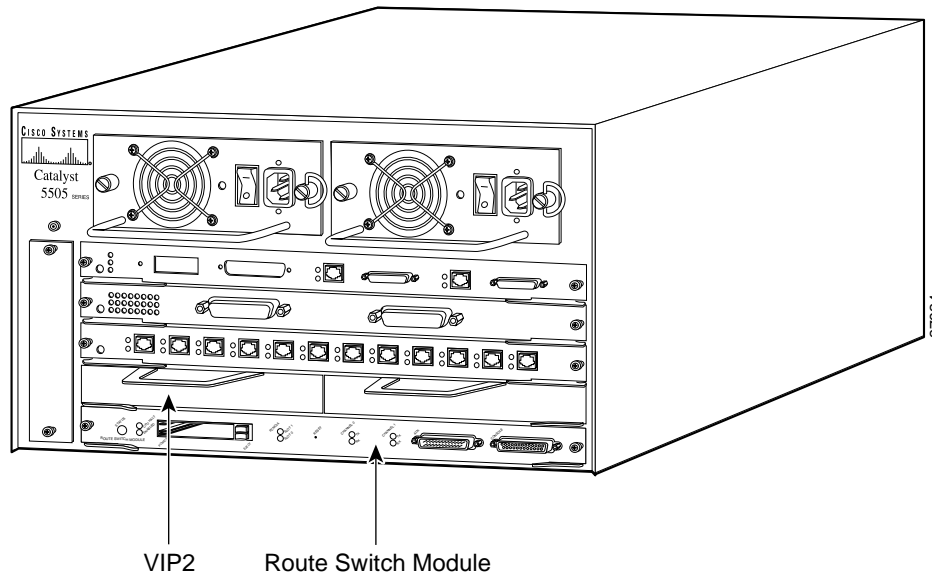

Catalyst 6000 Family FlexWAN Module Slot Numbering

The Catalyst 6000 family FlexWAN module can be installed in any slot except slot 1, which is reserved for the supervisor engine. The PA-8T-X21 can be installed into either port adapter bay 0 or bay 1 on a FlexWAN module. [Figure 1-6](#) shows a FlexWAN module with two blank port adapters installed.



Note

Slot 1 is reserved for the supervisor engine. If a redundant supervisor engine module is used, it would go in slot 2; otherwise, slot 2 can be used for other modules.

Figure 1-6 Catalyst 6000 Family Switch with Blank Port Adapters Installed on FlexWAN Module

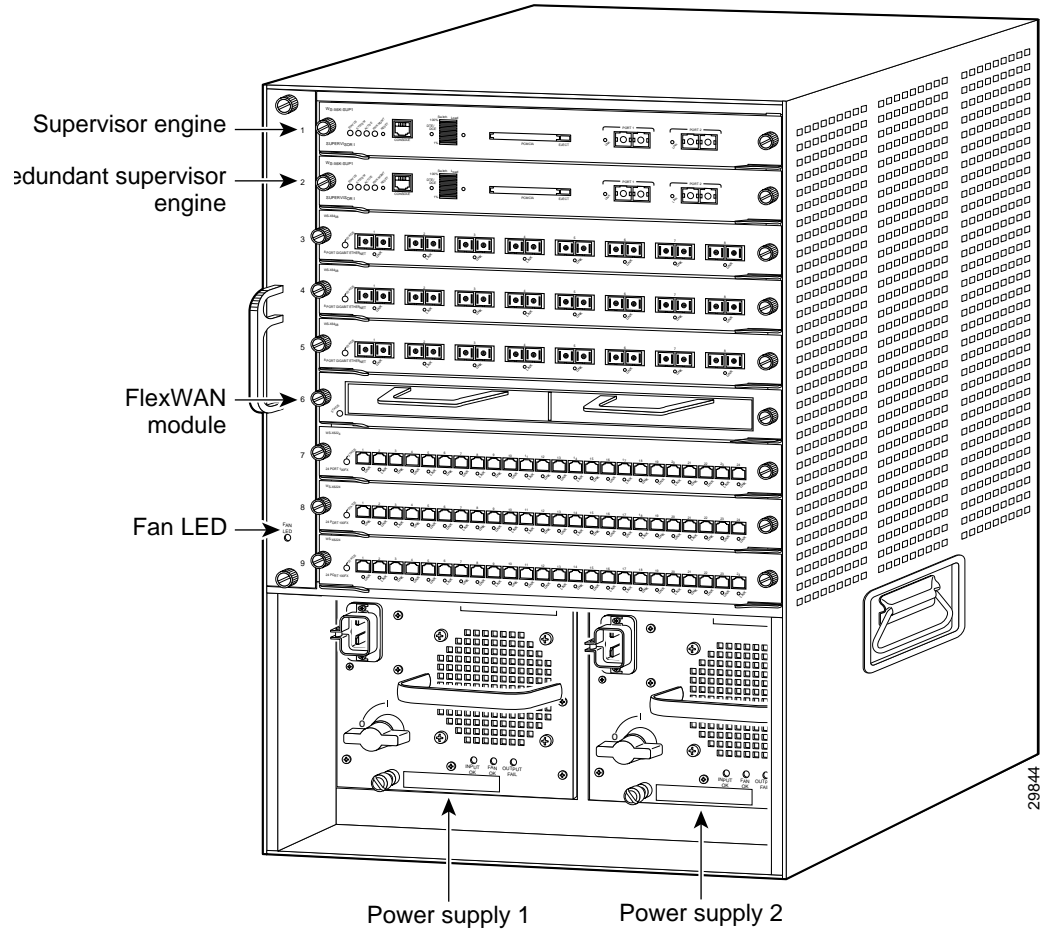

Cisco 7100 Series Routers Slot Numbering

The PA-8T-X21 can be installed in port adapter slot 3 in Cisco 7120 series routers, and in port adapter slot 4 in Cisco 7140 series routers. [Figure 1-7](#) shows a Cisco 7120 with a port adapter installed in slot 3. [Figure 1-8](#) shows a Cisco 7140 with a port adapter installed in slot 4.

Figure 1-7 Port Adapter Slots in the Cisco 7100 Series Router—Cisco 7120 Series

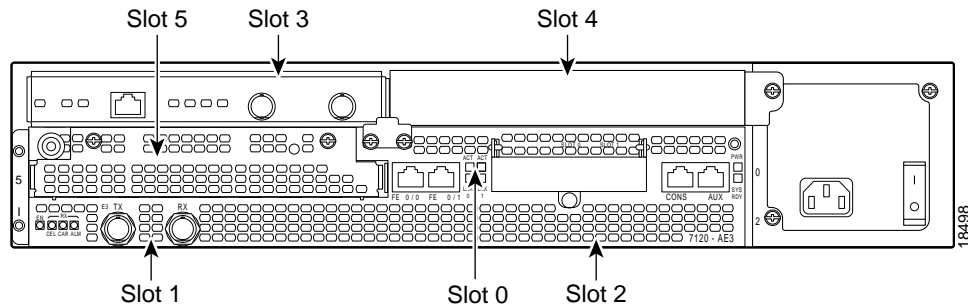
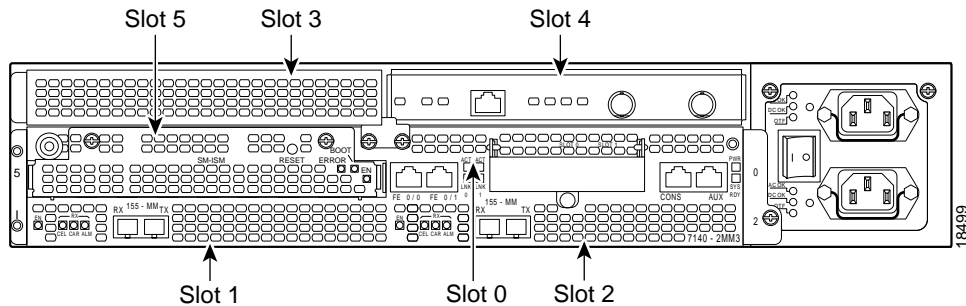

Figure 1-8 Port Adapter Slots in the Cisco 7100 Series Router—Cisco 7140 Series



Cisco 7200 Series and Cisco uBR7200 Series Routers Slot Numbering

Figure 1-9 shows a Cisco 7206 with port adapters installed. In the Cisco 7206, port adapter slot 1 is in the lower left position, and port adapter slot 6 is in the upper right position. (The Cisco 7202 and Cisco 7204 are not shown; however, the PA-8T-X21 can be installed in any available port adapter slot.)

Figure 1-9 Port Adapter Slots in the Cisco 7206

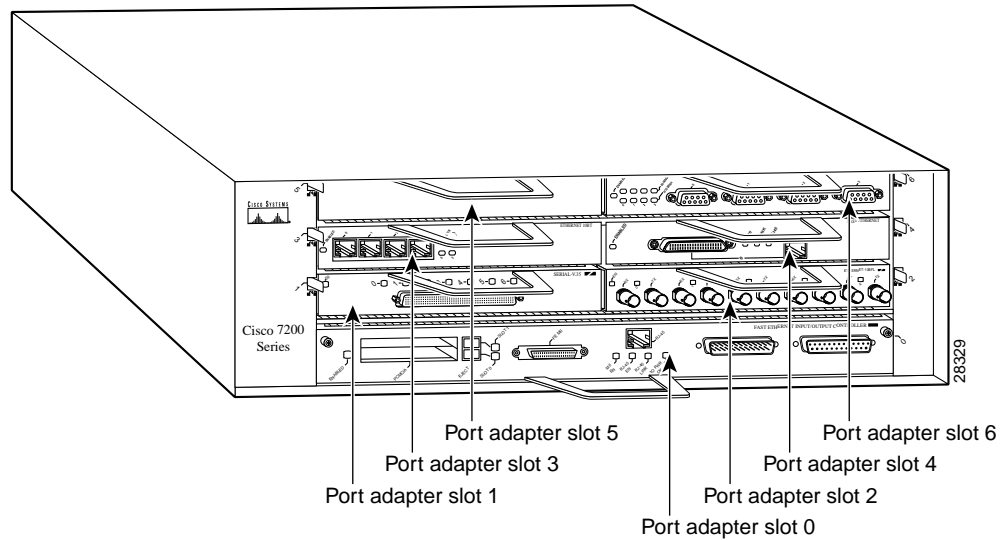
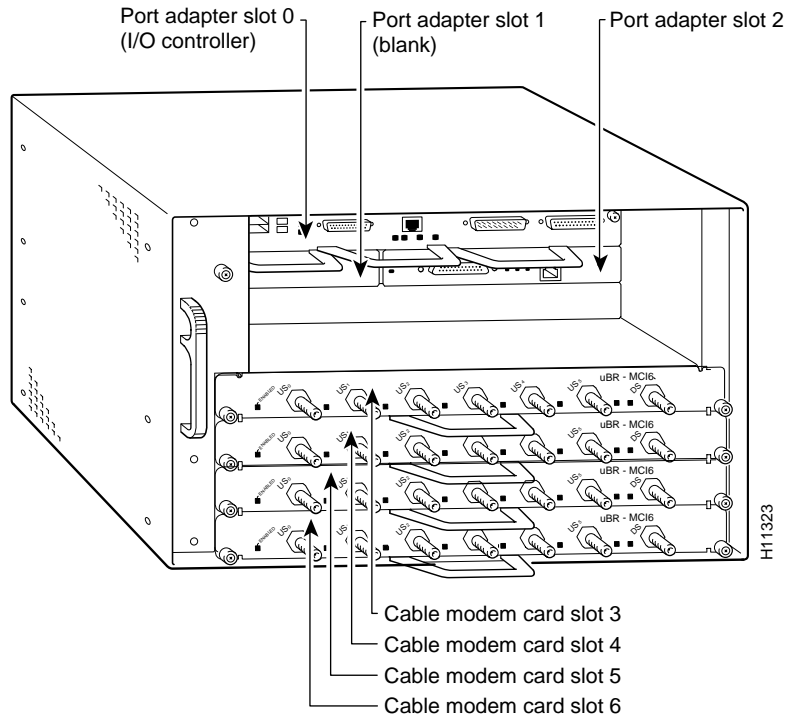

Figure 1-10 on page 1-20 shows the slot numbering of port adapters in a Cisco uBR7246 and Cisco uBR7246VXR router. The port adapter slots are numbered slot 1 and slot 2 for the Cisco uBR7246 and Cisco uBR7246VXR router and slot 1 for the Cisco uBR7223. (Slot 0 is always reserved for the Fast Ethernet port on the I/O controller—if present.)

Figure 1-10 Port Adapter Slots in the Cisco uBR7246 and Cisco uBR7246VXR



Cisco 7301 Router Slot Numbering

The Cisco 7301 router has one standard port adapter slot. See [Figure 1-11](#).

Figure 1-11 Port Adapter Slot in the Cisco 7301 Router

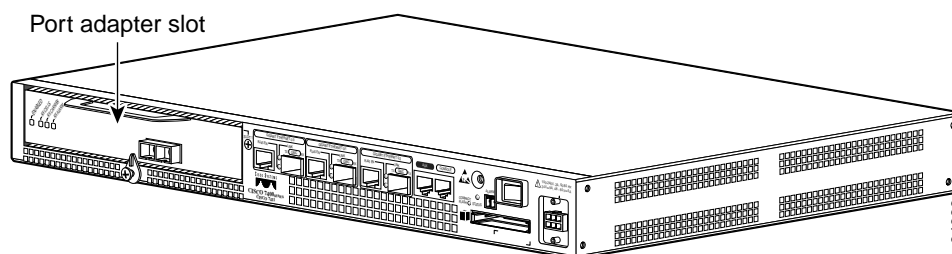

Cisco 7304 PCI Port Adapter Carrier Card Slot Numbering

The Cisco 7304 PCI Port Adapter Carrier Card accepts one single-width port adapter. [Figure 1-12](#) shows a Cisco 7304 PCI Port Adapter Carrier Card with a port adapter installed.

Figure 1-12 Cisco 7304 PCI Port Adapter Carrier Card—Port Adapter Installed

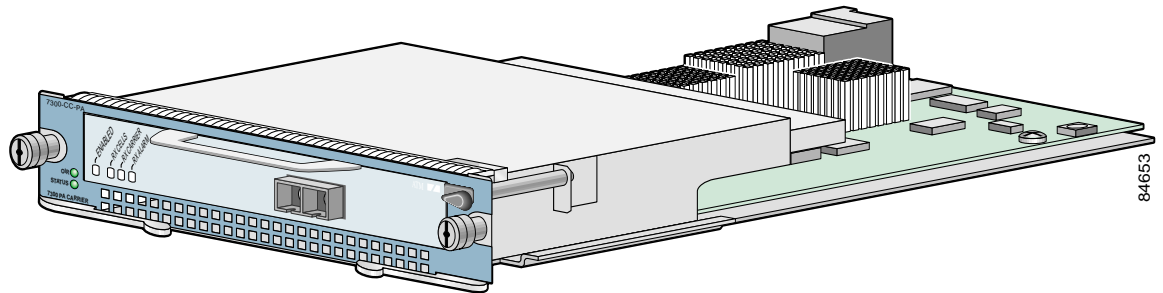

The Cisco 7304 PCI Port Adapter Carrier Card installs in Cisco 7304 router module slots 2 through 5. See [Figure 1-13](#) for module slot numbering on a Cisco 7304 router.

Figure 1-13 Module Slots on the Cisco 7304 Router

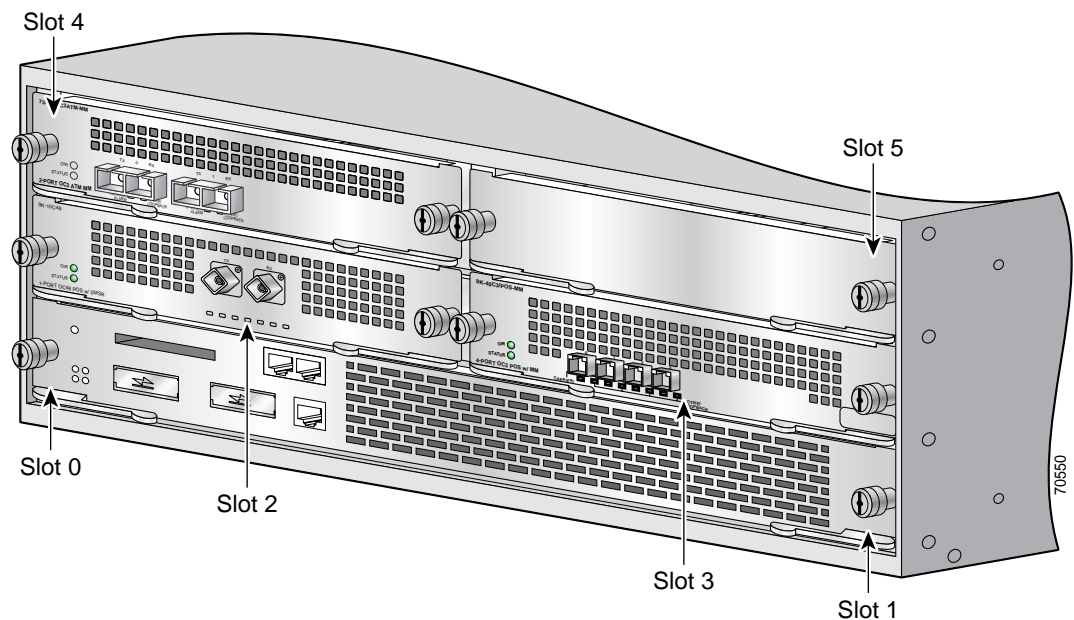

Cisco 7401ASR Router Slot Numbering

Figure 1-14 shows the front view of a Cisco 7401ASR router with a port adapter installed. There is only one port adapter slot in a Cisco 7401ASR router.

Figure 1-14 Cisco 7401ASR Router with a Port Adapter Installed

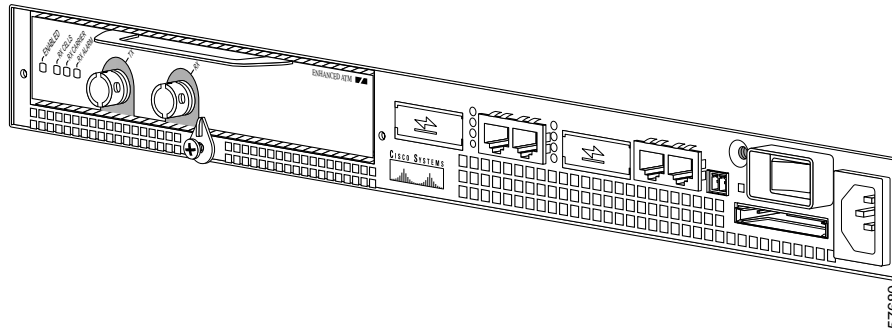

VIP Slot Numbering

Figure 1-15 shows a partial view of a VIP motherboard with installed port adapters. With the motherboard oriented as shown in Figure 1-15, the left port adapter is in port adapter slot 0, and the right port adapter is in port adapter slot 1. The slot numbering is the same for the Catalyst RSM/VIP2. The slots are always numbered 0 and 1.

Figure 1-15 VIP Motherboard with Two Port Adapters Installed—Horizontal Orientation

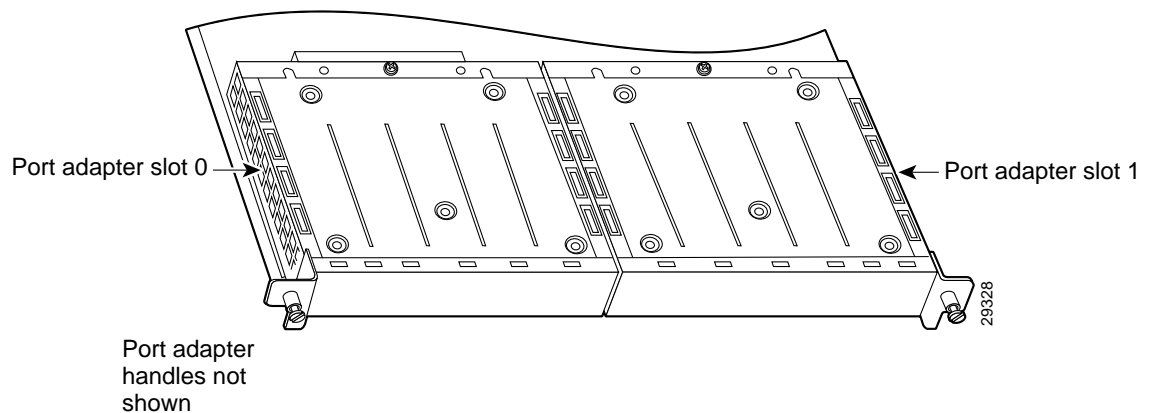

Note

In the Cisco 7000, Cisco 7507, and Cisco 7513 chassis, the VIP motherboard is installed vertically. In the Cisco 7010 and Cisco 7505 chassis, the VIP motherboard is installed horizontally.

Interface processor slots are numbered as shown in Figure 1-16.

Figure 1-16 Interface Slot Numbers—Cisco 7505 shown

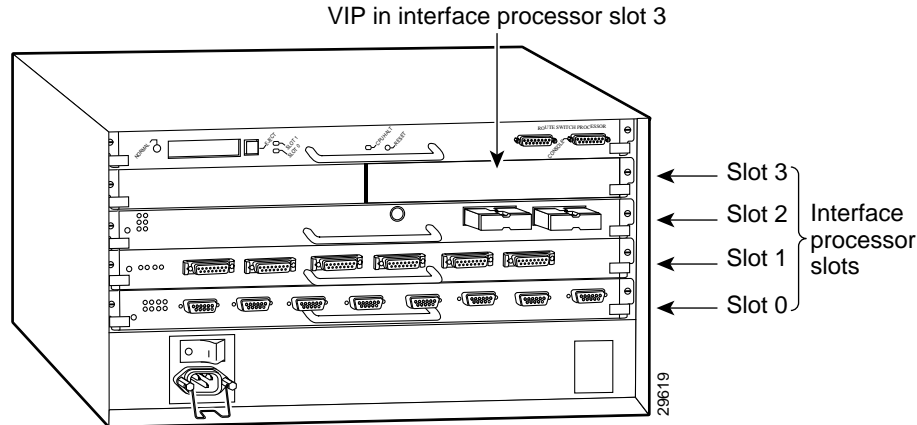

Identifying Interface Addresses

This section describes how to identify interface addresses for the PA-8T-X21 in supported platforms. Interface addresses specify the actual physical location of each interface on a router or switch.

Interfaces on the PA-8T-X21 installed in a router maintain the same address regardless of whether other port adapters are installed or removed. However, when you move a port adapter to a different slot, the first number in the interface address changes to reflect the new port adapter slot number.

Interfaces on a PA-8T-X21 installed in a Catalyst 6000 family FlexWAN module or a VIP maintain the same address regardless of whether other interface processors are installed or removed. However, when you move a VIP to a different slot, the interface processor slot number changes to reflect the new interface processor slot.



Note

Interface ports are numbered from left to right starting with 0.

Table 1-5 explains how to identify interface addresses.

Table 1-5 Identifying Interface Addresses

Platform	Interface Address Format	Numbers	Syntax
Catalyst RSM/VIP2 in Catalyst 5000 family switches	Port-adapter-slot-number/interface-port-number	Port adapter slot—always 0 or 1 Interface port—0 through 7	0/1
Catalyst 6000 family FlexWAN module in Catalyst 6000 family switches	Module-slot-number/port-adapter-bay-number/ interface-port-number	Module slot number—2 ¹ through 6 or 9 (depending on the number of slots in the switch) Port adapter bay—always 0 or 1 Interface port—0 through 7	3/0/0

Table 1-5 Identifying Interface Addresses (continued)

Platform	Interface Address Format	Numbers	Syntax
Cisco 7120 series routers	Port-adapter-slot-number/interface-port-number	Port adapter slot—always 3 Interface port—0 through 7	3/1
Cisco 7140 series routers	Port-adapter-slot-number/interface-port-number	Port adapter slot—always 4 Interface port—0 through 7	4/0
Cisco 7200 series routers	Port-adapter-slot-number/interface-port-number	Port adapter slot—0 through 6 (depends on the number of slots in the router) ² Interface port—0 through 7	1/0
Cisco uBR7223 router	Port-adapter-slot-number/interface-port-number	Port adapter slot—always 1 ² Interface port—0 through 7	1/0
Cisco uBR7246 and Cisco uBR7246VXR routers	Port-adapter-slot-number/interface-port-number	Port adapter slot—always 1 or 2 ² Interface port—0 through 7	1/2
Cisco 7301 router	Port-adapter-slot-number/interface-port-number	Port adapter slot—always 1 Interface port—0 through 7	1/1
Cisco 7304 PCI Port Adapter Carrier Card in Cisco 7304 routers	Port-adapter-slot-number/interface-port-number	Port adapter slot—router module slot 2 through 5 Interface port—0 through 7	3/0
Cisco 7401ASR routers	Port-adapter-slot-number/interface-port-number	Port adapter slot—always 1 Interface port—0 through 7	1/1
VIP in Cisco 7000 series or Cisco 7500 series routers	Interface-processor-slot-number/port-adapter-slot-number/interface-port-number	Interface processor slot—0 through 12 (depends on the number of slots in the router) Port adapter slot—always 0 or 1 Interface port—0 through 7	3/1/0

1. Slot 1 is reserved for the supervisor engine. If a redundant supervisor engine is used, it must go in slot 2; otherwise, slot 2 can be used for other modules.
2. Port adapter slot 0 is reserved for the Fast Ethernet port on the I/O controller (if present).

Catalyst RSM/VIP2 Interface Addresses

This section describes how to identify the interface addresses used for the PA-8T-X21 on the Catalyst RSM/VIP2 in Catalyst 5000 family switches. The interface address is composed of a two-part number in the format *port-adapter-slot number/interface-port number*.

See [Table 1-5 on page 1-23](#) for the interface address format.

Catalyst 6000 Family FlexWAN Module Interface Addresses

This section describes how to identify the interface addresses used for the PA-8T-X21 on the Catalyst FlexWAN module in Catalyst 6000 family switches. The interface address is composed of a three-part number in the format *module-number/port-adapter-bay-number/interface-port-number*.

See [Table 1-5 on page 1-23](#) for the interface address format.

If the FlexWAN module is inserted in module slot 3, then the interface addresses of the PA-8T-X21 are 3/0/0 through 3/0/7 (module slot 3, port adapter bay 0, and interfaces 0 through 7). If the port adapter was in port adapter bay 1 on the FlexWAN module, these same interface addresses would be numbered 3/1/0 through 3/1/7.

**Note**

If you remove the FlexWAN module with the PA-8T-X21 from module slot 3 and install it in module slot 6, the interface addresses become 6/0/0 through 6/0/7.

**Note**

The FlexWAN module physical port address uses a zero- (0-) based port address, which differs from the conventional Catalyst 6000 family one- (1-) based port address.

Cisco 7100 Series Routers Interface Addresses

This section describes how to identify the interface addresses used for the PA-8T-X21 in Cisco 7100 series routers. The interface address is composed of a two-part number in the format *port-adapter-slot-number/interface-port-number*. See [Table 1-5](#) for the interface address format.

Cisco 7200 Series and Cisco uBR7200 Series Routers Interface Addresses

This section describes how to identify the interface addresses used for the PA-8T-X21 in Cisco 7200 series routers or Cisco uBR7200 series routers. The interface address is composed of a two-part number in the format *port-adapter-slot-number/interface-port-number*. See [Table 1-5](#) for the interface address format.

In Cisco 7200 series routers, port adapter slots are numbered from the lower left to the upper right, beginning with port adapter slot 1 and continuing through port adapter slot 2 for the Cisco 7202, slot 4 for the Cisco 7204 and Cisco 7204VXR, and slot 6 for the Cisco 7206 and Cisco 7206VXR. (Port adapter slot 0 is reserved for the optional Fast Ethernet port on the I/O controller—if present.)

The interface addresses of the interfaces on the PA-8T-X21 in port adapter slot 1 are 1/0 through 1/7 (port adapter slot 1 and interfaces 0 through 7). If the PA-8T-X21 was in port adapter slot 4, these same interfaces would be numbered 4/0 through 4/7 (port adapter slot 4 and interfaces 0 through 7).

In Cisco uBR7200 series routers, port adapter slots are numbered slot 1 and slot 2 for the Cisco uBR7246 and Cisco uBR7246VXR and slot 1 for the Cisco uBR7223. (Slot 0 is always reserved for the Fast Ethernet port on the I/O controller—if present.) The individual interfaces always begin with 0. The number of additional interfaces depends on the number of interface ports on a port adapter.

The interface addresses of the interfaces on a PA-8T-X21 in port adapter slot 2 are 2/0 and 2/1 (port adapter slot 2 and interfaces 0 and 1). If the PA-8T-X21 was in port adapter slot 1, these same interfaces would be numbered 1/0 and 1/1 (port adapter slot 1 and interfaces 0 and 1).

Cisco 7301 Router Interface Addresses

This section describes how to identify the interface addresses used for the PA-8T-X21 port adapter in Cisco 7301 router. The interface address is composed of a two-part number in the format *port-adapter-slot-number/interface-port-number*. See [Table 1-5 on page 1-23](#) for the interface address format.

Cisco 7304 PCI Port Adapter Carrier Card Interface Addresses

This section describes how to identify the interface addresses used for the PA-8T-X21 in the Cisco 7304 PCI Port Adapter Carrier Card in Cisco 7304 routers. The interface address is made of a two-part number in the format *port-adapter-slot-number/interface-port-number*.

The Cisco 7304 PCI Port Adapter Carrier Card installs into Cisco 7304 router module slots 2 through 5 (See [Figure 1-13](#).) The port-adapter-slot-number is the Cisco 7304 router module slot number. For example, the interface address of port 0 on a PA-8T-X21, in which the Cisco 7304 PCI Port Adapter Carrier Card is installed in Cisco 7304 router module slot 3, would be numbered 3/0.

Cisco 7401ASR Router Interface Addresses

This section describes how to identify the interface addresses used for the PA-8T-X21 in the Cisco 7401ASR router. In the Cisco 7401ASR router, slot 1 is the port adapter slot you use for the PA-8T-X21. The interface address is composed of a two-part number in the format *port-adapter-slot-number/interface-port-number*. See [Table 1-5 on page 1-23](#) for the interface address format.

VIP Interface Addresses

This section describes how to identify the interface addresses used for the PA-8T-X21 on a VIP in Cisco 7000 series and Cisco 7500 series routers.



Note

Although the processor slots in the 7-slot Cisco 7000 and Cisco 7507 and the 13-slot Cisco 7513 and Cisco 7576 are vertically oriented and those in the 5-slot Cisco 7010 and Cisco 7505 are horizontally oriented, all Cisco 7000 series and Cisco 7500 series routers use the same method for slot and port numbering.

See [Table 1-5 on page 1-23](#) for the interface address format. The interface address is composed of a three-part number in the format *interface-processor-slot-number/port-adapter-slot-number/interface-port-number*.

If the VIP is inserted in interface processor slot 3, then the interface addresses of the PA-8T-X21 are 3/1/0 through 3/1/7 (interface processor slot 3, port adapter slot 1, and interfaces 0 through 7). If the port adapter was in port adapter slot 0 on the VIP, these same interface addresses would be numbered 3/0/0 through 3/0/7.



Note

If you remove the VIP with the PA-8T-X21 (shown in [Figure 1-16 on page 1-23](#)) from interface processor slot 3 and install it in interface processor slot 2, the interface addresses become 2/1/0 through 2/1/7.



Preparing for Installation

This chapter describes the general equipment, safety, and site preparation requirements for installing the Cisco PA-8T-X21 synchronous serial port adapter. This chapter contains the following sections:

- [Required Tools and Equipment, page 2-1](#)
- [Software and Hardware Requirements, page 2-2](#)
- [Checking Hardware and Software Compatibility, page 2-3](#)
- [Safety Guidelines, page 2-3](#)
- [FCC Class A Compliance, page 2-9](#)

Required Tools and Equipment

You need the following tools and parts to install a port adapter. If you need additional equipment, contact a service representative for ordering information.

- PA-8T-X21(=) port adapter.
- Catalyst RSM/VIP2 (for installation in the Catalyst 5000 family switches). For information about the specific VIP2 models that support the PA-8T-X21, see the [“Software and Hardware Requirements” section on page 2-2](#).
- Catalyst 6000 family FlexWAN module (for installation in the Catalyst 6000 family switches)
- VIP (for installation in Cisco 7000 series or Cisco 7500 series chassis only). For information about the specific VIP models that support the PA-8T-X21, see the [“Software and Hardware Requirements” section on page 2-2](#).
- Cisco 7304 PCI Port Adapter Carrier Card (for installation in a Cisco 7304 router).
- PA-8T-X21 compact serial cable (PA-8T-X21 compact serial cables are available *only* from Cisco Systems; they are *not* available from outside commercial cable vendors).
- Number 1 Phillips and a 3/16-inch flat-blade screwdriver (for VIP installation only).
- Number 2 Phillips screwdriver.
- Your own electrostatic discharge (ESD)-prevention equipment or the disposable grounding wrist strap included with all upgrade kits, field-replaceable units (FRUs), and spares.
- Antistatic mat.
- Antistatic container.

Software and Hardware Requirements

Table 2-1 lists the recommended minimum Cisco IOS software release required to use the PA-8T-X21 in supported router or switch platforms.

Table 2-1 PA-8T-X21 Software Requirements

Platform	Recommended Minimum Cisco IOS Release
Catalyst 5000 family switches with Catalyst RSM/VIP2¹ <ul style="list-style-type: none"> With Catalyst RSM/VIP2-15(=) or Catalyst RSM/VIP2-40(=) 	Cisco IOS Release 11.2(15)P or a later release of Cisco IOS Release 11.2 P
Catalyst 6000 family switches with Catalyst 6000 family FlexWAN module <ul style="list-style-type: none"> Catalyst 6000 family MSFC² Supervisor engine software 	Cisco IOS Release 12.1(1)EX or later Catalyst 6000 family supervisor engine software release 5.4(1) or later
Cisco 7100 series <ul style="list-style-type: none"> Cisco 7120 series and Cisco 7140 series 	Cisco IOS Release 12.0(4)XE or a later release of Cisco IOS Release 12.0 XE Cisco IOS Release 12.0(5)T or a later release of Cisco IOS Release 12.0 T
Cisco 7200 series³ <ul style="list-style-type: none"> Cisco 7204VXR and Cisco 7206VXR 	Cisco IOS Release 12.0(3)T or a later release of Cisco IOS Release 12.0 T Cisco IOS Release 12.0(2)XE2 or a later release of Cisco IOS Release 12.0 XE Cisco IOS Release 12.2(4)B or a later release of Cisco IOS Release 12.2 B
<ul style="list-style-type: none"> Cisco 7204 and Cisco 7206 	Cisco IOS Release 11.1(7)CA or a later release of Cisco IOS Release 11.1 Cisco IOS Release 12.2(4)B or a later release of Cisco IOS Release 12.2 B
<ul style="list-style-type: none"> Cisco 7202 	Cisco IOS Release 11.1(7)CA or a later release of Cisco IOS Release 11.1 Cisco IOS Release 12.2(4)B or a later release of Cisco IOS Release 12.2 B
Cisco uBR7200 series <ul style="list-style-type: none"> Cisco uBR7246 and Cisco uBR7223 	Cisco IOS Release 11.3(7)NA or a later release of Cisco IOS Release 11.3 NA Cisco IOS Release 12.0(3)T or a later release of Cisco IOS Release 12.0 T
Cisco 7301 router	Cisco IOS Release 12.2(11)YZ or a later release of Cisco IOS Release 12.2
Cisco 7304 routers With Cisco 7304 PCI Port Adapter Carrier Card	Cisco IOS Release 12.2(14)SZ or a later release of Cisco IOS Release 12.2SZ
Cisco 7401ASR routers	Cisco IOS Release 12.2(1)DX or a later release of Cisco IOS Release 12.1 DX Cisco IOS Release 12.2(4)B or a later release of Cisco IOS Release 12.2 B
VIP in the Cisco 7000 series and Cisco 7500 series	Cisco IOS Release 11.1(7)CA or a later release of Cisco IOS Release 11.1 CA Cisco IOS Release 11.1(14)CA or a later release of Cisco IOS Release 11.1 CA

- The specific Catalyst RSM/VIP2 model recommended for the PA-8T-X21 is the VIP2-40, which has 2 MB of SRAM and 32 MB of DRAM. The PA-8T-X21 is also supported by the VIP2-15 with 1 MB of SRAM and 16 MB of DRAM, but we do not recommend its use with this model.
- MSFC = Multi layer Switch Feature Card.
- Cisco IOS Release 11.2(7a)P or a later release of 11.2 P supports half-duplex and binary synchronous communications (Bisync) operation on PA-8T-X21 port adapters in Cisco 7200 series routers.

For configuration guidelines on port adapters in the Cisco 7200 series, refer to the *Cisco 7200 Series Port Adapter Hardware Configuration Guidelines*.

Checking Hardware and Software Compatibility

To check the minimum software requirements of Cisco IOS software with the hardware installed on your router, Cisco maintains the Software Advisor tool on Cisco.com. This tool does not verify whether modules within a system are compatible, but it does provide the minimum IOS requirements for individual hardware modules or components.



Note

Access to this tool is limited to users with Cisco.com login accounts.

To access Software Advisor, click **Login** at Cisco.com and go to **Technical Support Help—Cisco TAC: Tool Index: Software Advisor**. You can also access the tool by pointing your browser directly to <http://www.cisco.com/cgi-bin/support/CompNav/Index.pl>.

Choose a product family or enter a specific product number to search for the minimum supported software release needed for your hardware

Safety Guidelines

This section provides safety guidelines that you should follow when working with any equipment that connects to electrical power or telephone wiring.

Safety Warnings

Safety warnings appear throughout this publication in procedures that, if performed incorrectly, might harm you. A warning symbol precedes each warning statement.



Warning

IMPORTANT SAFETY INSTRUCTIONS

This warning symbol means danger. You are in a situation that could cause bodily injury. Before you work on any equipment, be aware of the hazards involved with electrical circuitry and be familiar with standard practices for preventing accidents. To see translations of the warnings that appear in this publication, refer to the translated safety warnings that accompanied this device.

Note: SAVE THESE INSTRUCTIONS

Note: This documentation is to be used in conjunction with the specific product installation guide that shipped with the product. Please refer to the Installation Guide, Configuration Guide, or other enclosed additional documentation for further details.

Waarschuwing BELANGRIJKE VEILIGHEIDSINSTRUCTIES

Dit waarschuwingssymbool betekent gevaar. U verkeert in een situatie die lichamelijk letsel kan veroorzaken. Voordat u aan enige apparatuur gaat werken, dient u zich bewust te zijn van de bij elektrische schakelingen betrokken risico's en dient u op de hoogte te zijn van de standaard praktijken om ongelukken te voorkomen. Voor een vertaling van de waarschuwingen die in deze publicatie verschijnen, dient u de vertaalde veiligheidswaarschuwingen te raadplegen die bij dit apparaat worden geleverd.

Opmerking **BEWAAR DEZE INSTRUCTIES.**

Opmerking Deze documentatie dient gebruikt te worden in combinatie met de installatiehandleiding voor het specifieke product die bij het product wordt geleverd. Raadpleeg de installatiehandleiding, configuratiehandleiding of andere verdere ingesloten documentatie voor meer informatie.

Varoitus TÄRKEITÄ TURVALLISUUTEEN LIITTYVIÄ OHJEITA

Tämä varoitusmerkki merkitsee vaaraa. Olet tilanteessa, joka voi johtaa ruumiinvammaan. Ennen kuin työskentelet minkään laitteiston parissa, ota selvää sähkökytkentöihin liittyvistä vaaroista ja tavanomaisista onnettomuuksien ehkäisykeinoista. Tässä asiakirjassa esitetyjen varoitusten käännökset löydät laitteen mukana toimitetuista ohjeista.

Huomautus **SÄILYTÄ NÄMÄ OHJEET**

Huomautus Tämä asiakirja on tarkoitettu käytettäväksi yhdessä tuotteen mukana tulleen asennusoppaan kanssa. Katso lisätietoja asennusoppaasta, kokoonpano-oppaasta ja muista mukana toimitetuista asiakirjoista.

Attention IMPORTANTES INFORMATIONS DE SÉCURITÉ

Ce symbole d'avertissement indique un danger. Vous vous trouvez dans une situation pouvant causer des blessures ou des dommages corporels. Avant de travailler sur un équipement, soyez conscient des dangers posés par les circuits électriques et familiarisez-vous avec les procédures couramment utilisées pour éviter les accidents. Pour prendre connaissance des traductions d'avertissements figurant dans cette publication, consultez les consignes de sécurité traduites qui accompagnent cet appareil.

Remarque **CONSERVEZ CES INFORMATIONS**

Remarque Cette documentation doit être utilisée avec le guide spécifique d'installation du produit qui accompagne ce dernier. Veuillez vous reporter au Guide d'installation, au Guide de configuration, ou à toute autre documentation jointe pour de plus amples renseignements.

Warnung WICHTIGE SICHERHEITSANWEISUNGEN

Dieses Warnsymbol bedeutet Gefahr. Sie befinden sich in einer Situation, die zu einer Körperverletzung führen könnte. Bevor Sie mit der Arbeit an irgendeinem Gerät beginnen, seien Sie sich der mit elektrischen Stromkreisen verbundenen Gefahren und der Standardpraktiken zur Vermeidung von Unfällen bewusst. Übersetzungen der in dieser Veröffentlichung enthaltenen Warnhinweise sind im Lieferumfang des Geräts enthalten.

Hinweis BEWAHREN SIE DIESE SICHERHEITSANWEISUNGEN AUF

Hinweis Dieses Handbuch ist zum Gebrauch in Verbindung mit dem Installationshandbuch für Ihr Gerät bestimmt, das dem Gerät beiliegt. Entnehmen Sie bitte alle weiteren Informationen dem Handbuch (Installations- oder Konfigurationshandbuch o. Ä.) für Ihr spezifisches Gerät.

Figyelem! FONTOS BIZTONSÁGI ELŐÍRÁSOK

Ez a figyelmeztető jel veszélyre utal. Sérülésveszélyt rejtő helyzetben van. Mielőtt bármely berendezésen munkát végezte, legyen figyelemmel az elektromos áramkörök okozta kockázatokra, és ismerkedjen meg a szokásos balesetvédelmi eljárásokkal. A kiadványban szereplő figyelmeztetések fordítása a készülékhez mellékelt biztonsági figyelmeztetések között található.

Megjegyzés ŐRIZZE MEG EZEKET AZ UTASÍTÁSOKAT!

Megjegyzés Ezt a dokumentációt a készülékhez mellékelt üzembe helyezési útmutatóval együtt kell használni. További tudnivalók a mellékelt Üzembe helyezési útmutatóban (Installation Guide), Konfigurációs útmutatóban (Configuration Guide) vagy más dokumentumban található.

Avvertenza IMPORTANTI ISTRUZIONI SULLA SICUREZZA

Questo simbolo di avvertenza indica un pericolo. La situazione potrebbe causare infortuni alle persone. Prima di intervenire su qualsiasi apparecchiatura, occorre essere al corrente dei pericoli relativi ai circuiti elettrici e conoscere le procedure standard per la prevenzione di incidenti. Per le traduzioni delle avvertenze riportate in questo documento, vedere le avvertenze di sicurezza che accompagnano questo dispositivo.

Nota CONSERVARE QUESTE ISTRUZIONI

Nota La presente documentazione va usata congiuntamente alla guida di installazione specifica spedita con il prodotto. Per maggiori informazioni, consultare la Guida all'installazione, la Guida alla configurazione o altra documentazione acclusa.

Advarsel VIKTIGE SIKKERHETSINSTRUKSJONER

Dette varselssymbolet betyr fare. Du befinner deg i en situasjon som kan forårsake personskade. Før du utfører arbeid med utstyret, bør du være oppmerksom på farene som er forbundet med elektriske kretssystemer, og du bør være kjent med vanlig praksis for å unngå ulykker. For å se oversettelser av advarslene i denne publikasjonen, se de oversatte sikkerhetsvarslene som følger med denne enheten.

Merk TA VARE PÅ DISSE INSTRUKSJONENE

Merk Denne dokumentasjonen skal brukes i forbindelse med den spesifikke installasjonsveiledningen som fulgte med produktet. Vennligst se installasjonsveiledningen, konfigureringsveiledningen eller annen vedlagt tilleggsdokumentasjon for detaljer.

Aviso INSTRUÇÕES IMPORTANTES DE SEGURANÇA

Este símbolo de aviso significa perigo. O utilizador encontra-se numa situação que poderá ser causadora de lesões corporais. Antes de iniciar a utilização de qualquer equipamento, tenha em atenção os perigos envolvidos no manuseamento de circuitos eléctricos e familiarize-se com as práticas habituais de prevenção de acidentes. Para ver traduções dos avisos incluídos nesta publicação, consulte os avisos de segurança traduzidos que acompanham este dispositivo.

Nota GUARDE ESTAS INSTRUÇÕES

Nota Esta documentação destina-se a ser utilizada em conjunto com o manual de instalação incluído com o produto específico. Consulte o manual de instalação, o manual de configuração ou outra documentação adicional inclusa, para obter mais informações.

¡Advertencia! INSTRUCCIONES IMPORTANTES DE SEGURIDAD

Este símbolo de aviso indica peligro. Existe riesgo para su integridad física. Antes de manipular cualquier equipo, considere los riesgos de la corriente eléctrica y familiarícese con los procedimientos estándar de prevención de accidentes. Vea las traducciones de las advertencias que acompañan a este dispositivo.

Nota GUARDE ESTAS INSTRUCCIONES

Nota Esta documentación está pensada para ser utilizada con la guía de instalación del producto que lo acompaña. Si necesita más detalles, consulte la Guía de instalación, la Guía de configuración o cualquier documentación adicional adjunta.

Varning! VIKTIGA SÄKERHETSANVISNINGAR

Denna varningssignal signalerar fara. Du befinner dig i en situation som kan leda till personskada. Innan du utför arbete på någon utrustning måste du vara medveten om farorna med elkretsar och känna till vanliga förfaranden för att förebygga olyckor. Se översättningarna av de varningsmeddelanden som finns i denna publikation, och se de översatta säkerhetsvarningarna som medföljer denna anordning.

OBS! SPARA DESSA ANVISNINGAR

OBS! Denna dokumentation ska användas i samband med den specifika produktinstallationshandbok som medföljde produkten. Se installationshandboken, konfigurationshandboken eller annan bifogad ytterligare dokumentation för närmare detaljer.

Предупреждение ВАЖНЫЕ СВЕДЕНИЯ ПО БЕЗОПАСНОСТИ

Этот символ предупреждает о наличии опасности. При неправильных действиях возможно получение травм. Перед началом работы с любым оборудованием необходимо ознакомиться с ситуациями, в которых возможно поражение электротоком, и со стандартными действиями для предотвращения несчастных случаев. Переведенный текст предупреждений содержится в соответствующем документе, поставляемом вместе с устройством.

Примечание **СОХРАНЯЙТЕ ЭТУ ИНСТРУКЦИЮ**

Примечание Эта инструкция должна использоваться вместе с руководством по установке конкретного изделия, входящим в комплект поставки. Дополнительные сведения см. в руководстве по установке, руководстве по настройке и другой документации, поставляемой с изделием.

警告 有关安全的重要说明

这个警告符号指有危险。您所处的环境可能使身体受伤。操作设备前必须意识到电流的危险性，务必熟悉操作标准，以防发生事故。如果需要了解本说明中出现的警告符号的译文，请参阅本装置所附之安全警告译文。

注意 保存这些说明

注意 本文件应与本产品附带的具体安装说明一并阅读。如欲了解详情，请参阅《安装说明》、《配置说明》或所附的其他文件。

警告 安全上の重要な注意事項

「危険」の意味です。人身事故を予防するための注意事項が記述されています。装置の取り扱い作業を行うときは、電気回路の危険性に注意し、一般的な事故防止対策に留意してください。このマニュアルに記載されている警告の各国語版は、装置に付属の「Translated Safety Warnings」を参照してください。

注 これらの注意事項を保管しておいてください。

注 この資料は、製品に付属のインストラクション ガイドと併用してください。詳細は、インストラクション ガイド、コンフィギュレーション ガイド、または添付されているその他のマニュアルを参照してください。

Предупреждение ВАЖНЫЕ СВЕДЕНИЯ ПО БЕЗОПАСНОСТИ

Этот символ предупреждает о наличии опасности. При неправильных действиях возможно получение травм. Перед началом работы с любым оборудованием необходимо ознакомиться с ситуациями, в которых возможно поражение электротоком, и со стандартными действиями для предотвращения несчастных случаев. Переведенный текст предупреждений содержится в соответствующем документе, поставляемом вместе с устройством.

Примечание СОХРАНЯЙТЕ ЭТУ ИНСТРУКЦИЮ

Примечание Эта инструкция должна использоваться вместе с руководством по установке конкретного изделия, входящим в комплект поставки. Дополнительные сведения см. в руководстве по установке, руководстве по настройке и другой документации, поставляемой с изделием.

警告 有关安全的重要说明

这个警告符号指有危险。您所处的环境可能使身体受伤。操作设备前必须意识到电流的危险性，务必熟悉操作标准，以防发生事故。如果需要了解本说明中出现的警告符号的译文，请参阅本装置所附之安全警告译文。

注意 保存这些说明

注意 本文件应与本产品附带的具体安装说明一并阅读。如欲了解详情，请参阅《安装说明》、《配置说明》或所附的其他文件。

警告 安全上の重要な注意事項

「危険」の意味です。人身事故を予防するための注意事項が記述されています。装置の取り扱い作業を行うときは、電気回路の危険性に注意し、一般的な事故防止対策に留意してください。このマニュアルに記載されている警告の各国語版は、装置に付属の「Translated Safety Warnings」を参照してください。

注 これらの注意事項を保管しておいてください。

注 この資料は、製品に付属のインストレーション ガイドと併用してください。詳細は、インストレーション ガイド、コンフィギュレーション ガイド、または添付されているその他のマニュアルを参照してください。

Electrical Equipment Guidelines

Follow these basic guidelines when working with any electrical equipment:

- Before beginning any procedures requiring access to the chassis interior, locate the emergency power-off switch for the room in which you are working.
- Disconnect all power and external cables before moving a chassis; do not work alone when potentially hazardous conditions exist.
- Never assume that power has been disconnected from a circuit; always check.
- Do not perform any action that creates a potential hazard to people or makes the equipment unsafe; carefully examine your work area for possible hazards such as moist floors, ungrounded power extension cables, and missing safety grounds.

Telephone Wiring Guidelines

Use the following guidelines when working with any equipment that is connected to telephone wiring or to other network cabling:

- Never install telephone wiring during a lightning storm.
- Never install telephone jacks in wet locations unless the jack is specifically designed for wet locations.
- Never touch non insulated telephone wires or terminals unless the telephone line has been disconnected at the network interface.
- Use caution when installing or modifying telephone lines.

Preventing Electrostatic Discharge Damage

Electrostatic discharge (ESD) damage, which can occur when electronic cards or components are improperly handled, results in complete or intermittent failures. Port adapters and processor modules comprise printed circuit boards that are fixed in metal carriers. Electromagnetic interference (EMI) shielding and connectors are integral components of the carrier. Although the metal carrier helps to protect the board from ESD, use a preventive antistatic strap during handling.

Following are guidelines for preventing ESD damage:

- Always use an ESD wrist or ankle strap and ensure that it makes good skin contact.
- Connect the equipment end of the strap to an unfinished chassis surface.
- When installing a component, use any available ejector levers or captive installation screws to properly seat the bus connectors in the backplane or midplane. These devices prevent accidental removal, provide proper grounding for the system, and help to ensure that bus connectors are properly seated.
- When removing a component, use any available ejector levers or captive installation screws to release the bus connectors from the backplane or midplane.
- Handle carriers by available handles or edges only; avoid touching the printed circuit boards or connectors.
- Place a removed board component-side-up on an antistatic surface or in a static shielding container. If you plan to return the component to the factory, immediately place it in a static shielding container.
- Avoid contact between the printed circuit boards and clothing. The wrist strap only protects components from ESD voltages on the body; ESD voltages on clothing can still cause damage.
- Never attempt to remove the printed circuit board from the metal carrier.



Caution

For safety, periodically check the resistance value of the antistatic strap. The measurement should be between 1 and 10 megohms (Mohm).

FCC Class A Compliance

This equipment has been tested and found to comply with the limits for a Class A digital device, pursuant to part 15 of the FCC rules. These limits are designed to provide reasonable protection against harmful interference when the equipment is operated in a commercial environment. This equipment generates, uses, and can radiate radio-frequency energy and, if not installed and used in accordance with the instruction manual, may cause harmful interference to radio communications. Operation of this equipment in a residential area is likely to cause harmful interference, in which case users will be required to correct the interference at their own expense.

You can determine whether your equipment is causing interference by turning it off. If the interference stops, it was probably caused by the Cisco equipment or one of its peripheral devices. If the equipment causes interference to radio or television reception, try to correct the interference by using one or more of the following measures:

- Turn the television or radio antenna until the interference stops.
- Move the equipment to one side or the other of the television or radio.
- Move the equipment farther away from the television or radio.

- Plug the equipment into an outlet that is on a different circuit from the television or radio. (That is, make certain the equipment and the television or radio are on circuits controlled by different circuit breakers or fuses.)

**Note**

The Cisco PA-8T-X21 synchronous serial port adapter has been designed to meet these requirements. Modifications to this product that are not authorized by Cisco Systems, Inc., could void the various approvals and negate your authority to operate the product.



Removing and Installing Port Adapters

This chapter describes how to remove the Cisco PA-8T-X21 synchronous serial port adapter from supported platforms and also how to install a new or replacement port adapter. This chapter contains the following sections:

- [Handling Port Adapters, page 3-2](#)
- [Online Insertion and Removal, page 3-2](#)
- [Warnings and Cautions, page 3-3](#)
- [Port Adapter Removal and Installation, page 3-4](#)

Each port adapter circuit board is mounted to a metal carrier and is sensitive to electrostatic discharge (ESD) damage.



Note

When a port adapter slot is not in use, a blank port adapter must fill the empty slot to allow the router or switch to conform to electromagnetic interference (EMI) emissions requirements and to allow proper airflow across the port adapters. If you plan to install a new port adapter in a slot that is not in use, you must first remove the blank port adapter.



Caution

When powering off the router, wait a minimum of 30 seconds before powering it on again.

Handling Port Adapters



Caution

Always handle the port adapter by the carrier edges and handle; never touch the port adapter's components or connector pins. (See [Figure 3-1](#).)

Figure 3-1 Handling a Port Adapter

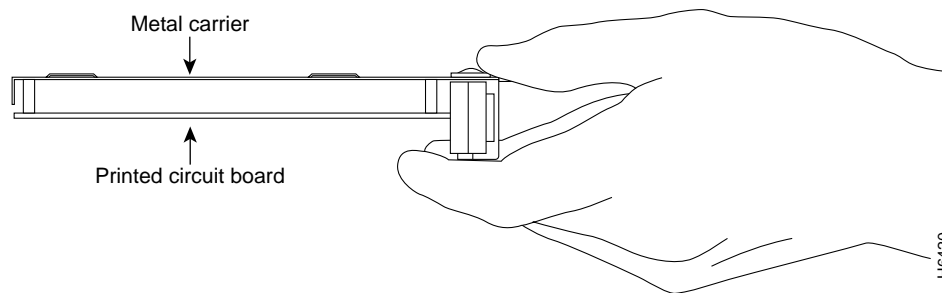

Online Insertion and Removal

Several platforms support online insertion and removal (OIR) of port adapters; therefore, you do not have to power down routers when removing and replacing a PA-8T-X21 on Cisco 7100 series routers, Cisco 7200 series routers, Cisco uBR7200 series routers, or Cisco 7301 routers.

Although the Cisco 7304 PCI Port Adapter Carrier Card, the Catalyst RSM/VIP2, the Catalyst 6000 family FlexWAN module and the VIP support online insertion and removal, individual port adapters do not. To replace port adapters, you must first remove the Cisco 7304 PCI Port Adapter Carrier Card, the Catalyst RSM/VIP2, the Catalyst 6000 family FlexWAN module, or the VIP from the chassis and then install or replace port adapters as required. If a blank port adapter is installed on the Cisco 7304 PCI Port Adapter Carrier Card, the Catalyst RSM/VIP2, the Catalyst 6000 family FlexWAN module, or the VIP on which you want to install a new port adapter, you must first remove the Cisco 7304 PCI Port Adapter Carrier Card, the Catalyst RSM/VIP2, the Catalyst 6000 family FlexWAN module, or the VIP from the chassis and then remove the blank port adapter.



Caution

To prevent system problems, do not remove port adapters from the Cisco 7304 PCI Port Adapter Carrier Card, the Catalyst RSM/VIP2, the Catalyst 6000 family FlexWAN module, or the VIP or attempt to install other port adapters on the motherboard when the system is operating. To install or replace port adapters, first remove the Cisco 7304 PCI Port Adapter Carrier Card, the Catalyst RSM/VIP2, the Catalyst 6000 family FlexWAN module, or the VIP from its interface processor slot.

It is wise to gracefully shut down the system before removing a port adapter that has active traffic moving through it. Removing a module while traffic is flowing through the ports can cause system disruption. Once the module is inserted, the ports can be brought back up.



Note

As you disengage the module from the router or switch, online insertion and removal (OIR) administratively shuts down all active interfaces in the module.

OIR allows you to install and replace modules while the router is operating; you do not need to notify the software or shut down the system power, although you should not run traffic through the module you are removing while it is being removed. OIR is a method that is seamless to end users on the network, maintains all routing information, and preserves sessions.

The following is a functional description of OIR for background information only; for specific procedures for installing and replacing a module in a supported platform, refer to the [“Port Adapter Removal and Installation” section on page 3-4](#).

Each module has a bus connector that connects it to the router. The connector has a set of tiered pins in three lengths that send specific signals to the system as they make contact with the module. The system assesses the signals it receives and the order in which it receives them to determine if a module is being removed from or introduced to the system. From these signals, the system determines whether to reinitialize a new interface or to shut down a disconnected interface.

Specifically, when you insert a module, the longest pins make contact with the module first, and the shortest pins make contact last. The system recognizes the signals and the sequence in which it receives them.

When you remove or insert a module, the pins send signals to notify the system of changes. The router then performs the following procedure:

1. Rapidly scans the system for configuration changes.
2. Initializes newly inserted port adapters or administratively shuts down any vacant interfaces.
3. Brings all previously configured interfaces on the module back to their previously installed state. Any newly inserted interface is put in the administratively shutdown state, as if it was present (but not configured) at boot time. If a similar module type is reinserted into a slot, its ports are configured and brought online up to the port count of the originally installed module of that type.

**Note**

Before you begin installation, read [Chapter 2, “Preparing for Installation”](#) for a list of parts and tools required for installation.

Warnings and Cautions

Observe the following warnings and cautions when installing or removing port adapters.

**Caution**

Do not slide a port adapter all the way into the slot until you have connected all required cables. Trying to do so will disrupt normal operation of the router or switch.

**Note**

If a port adapter lever or other retaining mechanism does not move to the locked position, the port adapter is not completely seated in the midplane. Carefully pull the port adapter halfway out of the slot, reinsert it, and move the port adapter lever to the locked position.

**Caution**

To prevent jamming the carrier between the upper and the lower edges of the port adapter slot, and to ensure that the edge connector at the rear of the port adapter mates with the connection at the rear of the port adapter slot, make certain that the carrier is positioned correctly, as shown in the cutaway in the following illustrations.

**Caution**

When performing the following procedures, wear a grounding wrist strap to avoid ESD damage to the card. Some platforms have an ESD connector for attaching the wrist strap.

**Warning**

Hazardous voltage or energy is present on the backplane when the system is operating. Use caution when servicing.

Port Adapter Removal and Installation

In this section, the illustrations that follow give step-by-step instruction on how to remove and install port adapters. This section contains the following illustrations:

- [Catalyst RSM/VIP2—Removing and Installing a Port Adapter, page 3-5](#)
- [Catalyst 6000 Family FlexWAN Module—Removing and Installing a Port Adapter, page 3-6](#)
- [Cisco 7100 Series—Removing and Installing a Port Adapter, page 3-7](#)
- [Cisco 7200 Series—Removing and Installing a Port Adapter, page 3-8](#)
- [Cisco uBR7200 Series—Removing a Port Adapter, page 3-9](#)
- [Cisco 7301 Series—Removing and Installing a Port Adapter, page 3-11](#)
- [Cisco 7304 PCI Port Adapter Carrier Card—Removing and Installing a Port Adapter, page 3-12](#)
- [Cisco 7401ASR Router—Removing and Installing a Port Adapter, page 3-14](#)
- [VIP—Removing and Installing a Port Adapter, page 3-15](#)

Catalyst RSM/VIP2—Removing and Installing a Port Adapter

Note: You must first remove the Catalyst RSM/VIP2 from the chassis before removing a port adapter from the Catalyst RSM/VIP2.

Step 1

To remove the port adapter, remove the screw that secures the port adapter (or blank port adapter). (See A.)

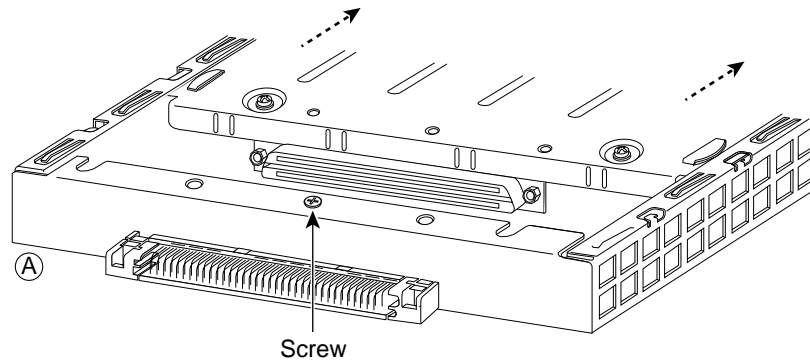

Step 2

With the screw removed, grasp the handle on the front of the port adapter (or blank port adapter) and carefully pull it out of its slot, away from the edge connector at the rear of the slot. (See A.)

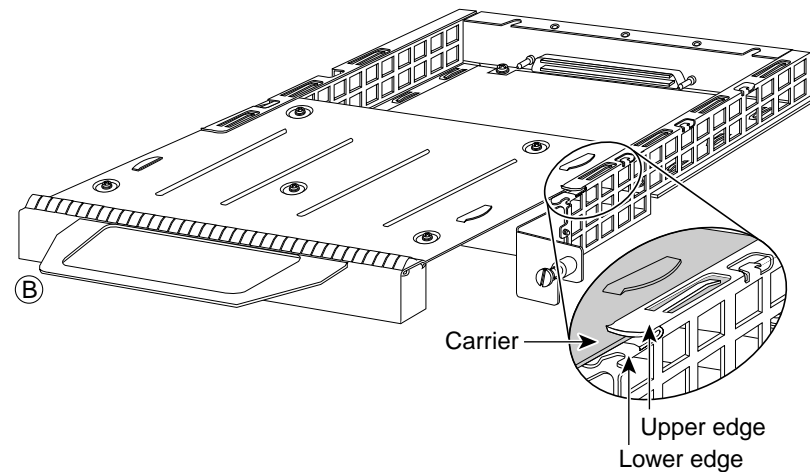

Step 3

To install the port adapter, carefully align the port adapter carrier between the upper and the lower edges of the port adapter slot. (See B.)

Step 4

Install the screw in the rear of the port adapter slot. Do not over-tighten the screw. (See A.)

Step 5

Carefully slide the new port adapter into the port adapter slot until the connector on the port adapter is completely seated in the connector at the rear of the port adapter slot. (See B.)

Step 6

Reinstall the Catalyst RSM/VIP2 motherboard in the chassis and tighten the captive installation screw on each side of the Catalyst RSM/VIP2 faceplate. (See C.)

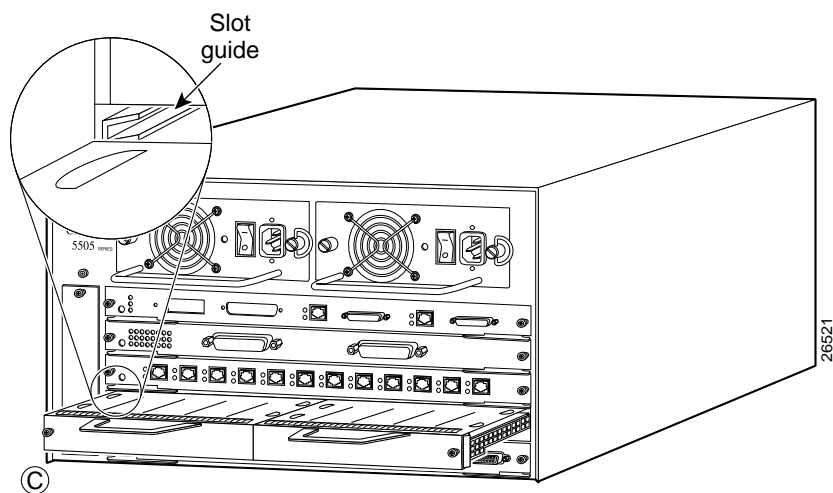

Catalyst 6000 Family FlexWAN Module—Removing and Installing a Port Adapter

Note: You must first remove the Catalyst 6000 FlexWAN module from the chassis before removing a port adapter from the Catalyst 6000 FlexWAN module.

Step 1

To remove the port adapter, remove the screw that secures the port adapter (or blank port adapter). (See A.)

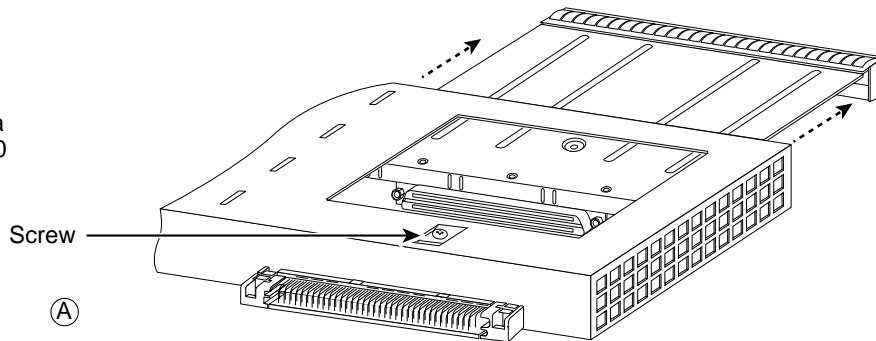

Step 2

With the screw removed, grasp the handle on the front of the port adapter (or blank port adapter) and carefully pull it out of its bay, away from the edge connector at the rear of the bay. (See A.)

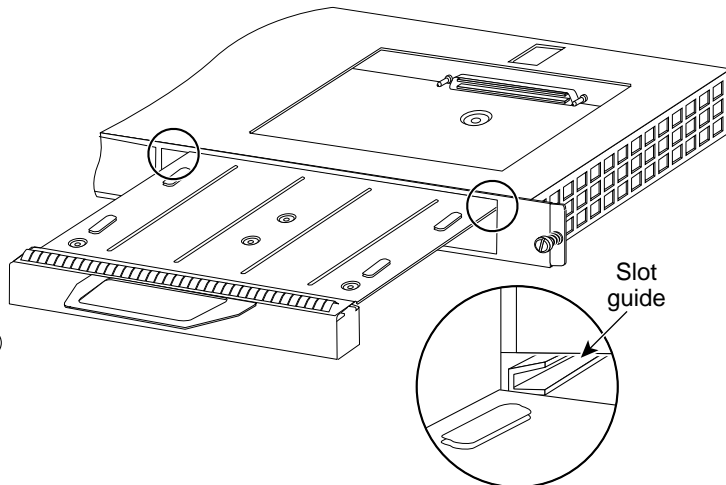

Step 3

To install the port adapter, carefully align the port adapter carrier between the upper and the lower edges of the port adapter bay. (See B.)

Step 4

Carefully slide the new port adapter into the port adapter bay until the connector on the port adapter is completely seated in the connector at the rear of the port adapter slot. (See B.)

Step 5

Install the screw in the rear of the port adapter bay. Do not overtighten the screw. (See A.)

Step 6

Reinstall the Catalyst 6000 FlexWAN module in the chassis, and tighten the captive installation screw on each side of the Catalyst 6000 FlexWAN module faceplate. (See C.)

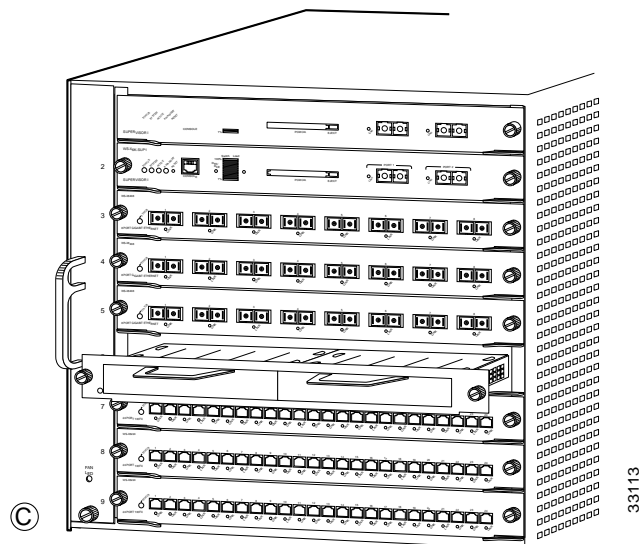

Cisco 7100 Series—Removing and Installing a Port Adapter

Step 1

To remove the port adapter, use a number 2 Phillips screwdriver to loosen the screws on the locking tab. Then slide the tab down to the unlocked position.

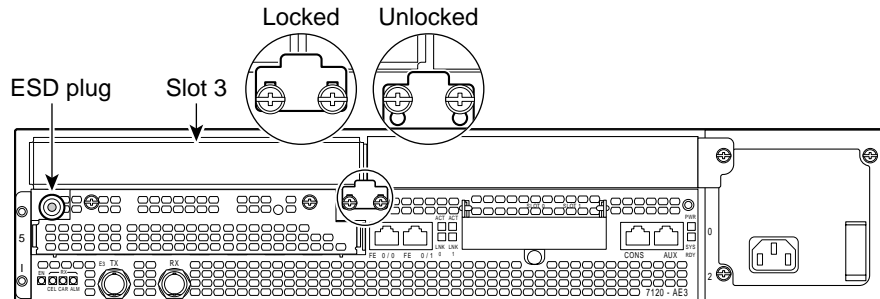

Step 2

Grasp the handle of the port adapter and pull the port adapter from the router, about halfway out of its slot. If you are removing a blank port adapter, pull the blank port adapter completely out of the chassis slot.

Step 3

With the port adapter halfway out of the slot, disconnect all cables from the port adapter.

Step 4

After disconnecting the cables, pull the port adapter from its chassis slot.

Step 5

To insert the port adapter, carefully align the port adapter carrier between the upper and the lower edges of the port adapter slot.

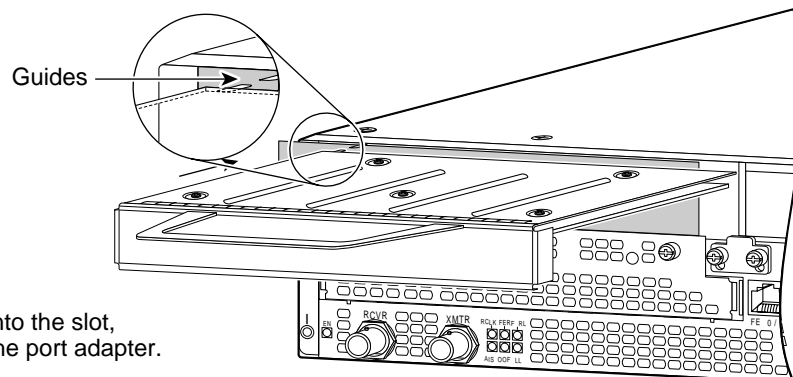

Step 6

With the port adapter halfway into the slot, connect all required cables to the port adapter.

Step 7

After connecting all required cables, carefully slide the port adapter all the way into the slot until the port adapter is seated in the router midplane.

Step 8

After the port adapter is properly seated, lock the port adapter retaining mechanism.

26522

Cisco 7200 Series—Removing and Installing a Port Adapter

Step 1

To remove the port adapter, place the port adapter lever in the unlocked position. (See A.) The port adapter lever remains in the unlocked position.

Step 2

Grasp the handle of the port adapter and pull the port adapter from the router, about halfway out of its slot. If you are removing a blank port adapter, pull the blank port adapter completely out of the chassis slot.

Step 3

With the port adapter halfway out of the slot, disconnect all cables from the port adapter. After disconnecting the cables, pull the port adapter from its chassis slot.

Step 4

To insert the port adapter, carefully align the port adapter carrier between the upper and the lower edges of the port adapter slot. (See B.)

Step 5

Carefully slide the new port adapter halfway into the port adapter slot. (See B.)

Step 6

With the port adapter halfway into the slot, connect all required cables to the port adapter. After connecting all required cables, carefully slide the port adapter all the way into the slot until the port adapter is seated in the router midplane.

Step 7

After the port adapter is properly seated, lock the port adapter lever. (See A.)

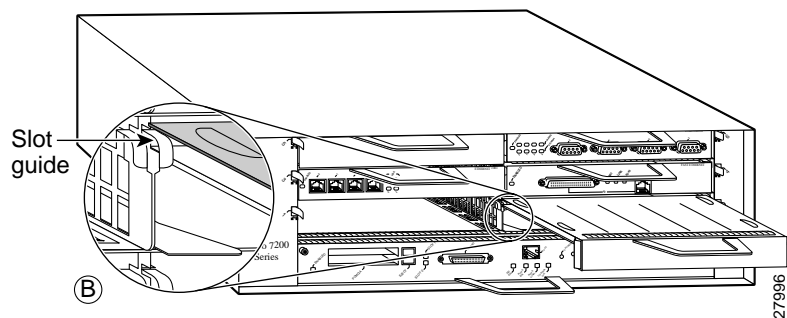
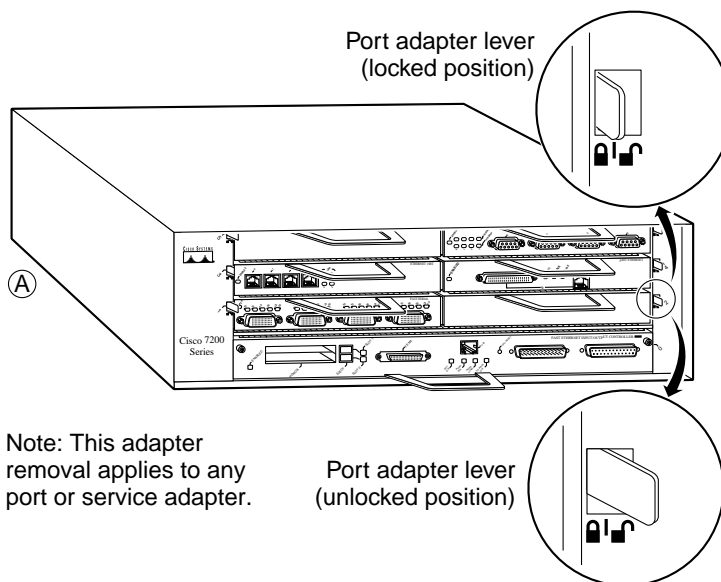

Cisco uBR7200 Series—Removing a Port Adapter

Step 1

To remove the port adapter, unlock the port adapter retaining mechanism. The port adapter lever remains in the unlocked position.

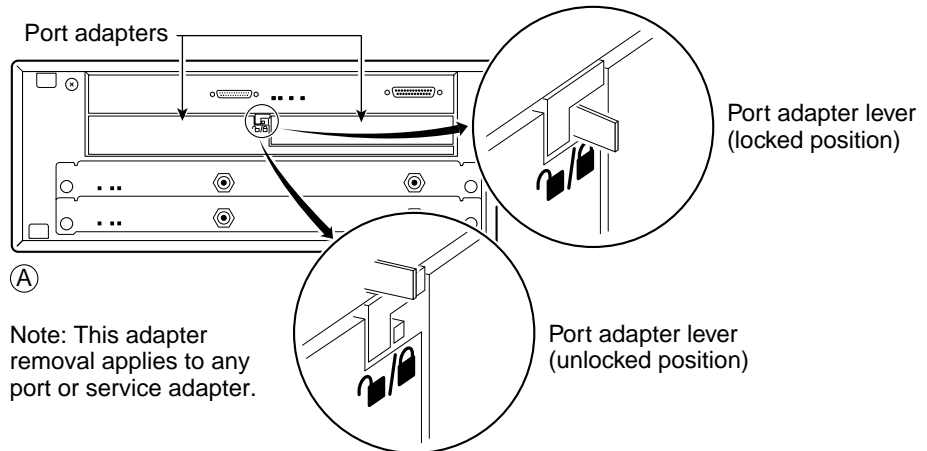

Place the port adapter lever (Cisco uBR7223, see A), or the port adapter retention clip (Cisco uBR7246 and Cisco uBR7246 VXR, see B) in the unlocked position. Either mechanism remains in the unlocked position.

Step 2

Grasp the handle of the port adapter and pull the port adapter from the router, about halfway out of its slot. If you are removing a blank port adapter, pull the blank port adapter completely out of the chassis slot.

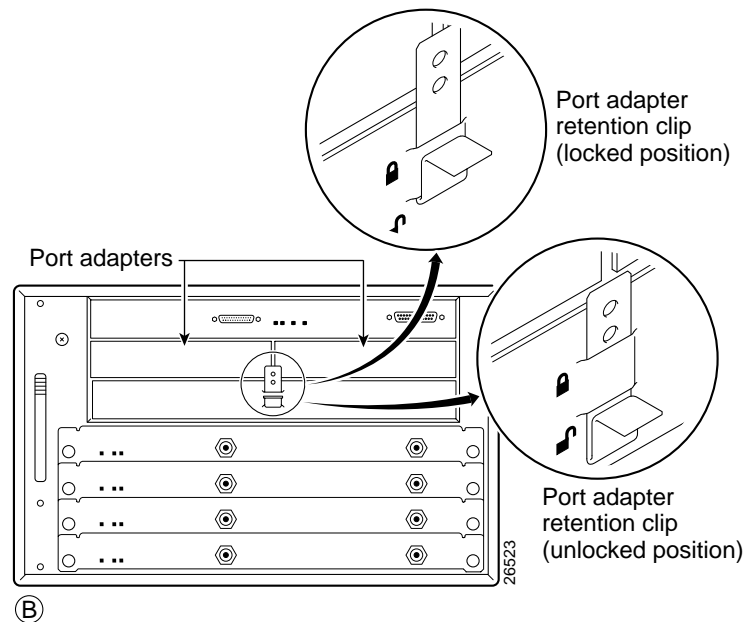

Step 3

With the port adapter halfway out of the slot, disconnect all cables from the port adapter. After disconnecting the cables, pull the port adapter from its chassis slot.

Cisco uBR7200 Series—Installing a Port Adapter

Step 1

To insert the port adapter, carefully align the port adapter carrier between the upper and the lower edges of the port adapter slot.

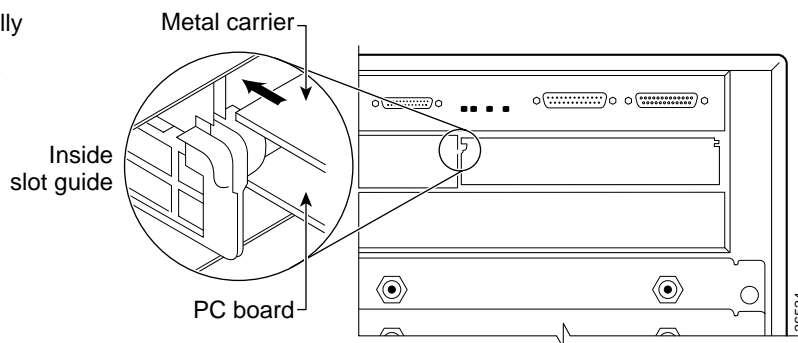

Step 2

Carefully slide the new port adapter halfway into the port adapter slot.

Step 3

With the port adapter halfway into the slot, connect all required cables to the port adapter. After connecting all required cables, carefully slide the port adapter all the way into the slot until the port adapter is seated in the router midplane.

Step 4

After the port adapter is properly seated, lock the port adapter lever or retention clip, depending on your system. (See illustration on preceding page.)

Cisco 7301 Series—Removing and Installing a Port Adapter

Step 1

Use an ESD wrist strap to ground yourself to the router.

Step 2

To remove a port adapter, use a Phillips screwdriver to turn the screw holding the port adapter latch. The screw should be loose enough to allow the latch to rotate to an unlocked position. (See A.) The latch can rotate 360°.

Step 3

Grasp the handle and pull the port adapter from the router, about halfway out of its slot. (See B.) If you are removing a blank port adapter, pull the blank port adapter completely out of the chassis slot.

Step 4

With the port adapter halfway out of the slot, disconnect all cables from the port adapter. After disconnecting the cables, pull the port adapter from its chassis slot.

Caution

The port adapter must slide into the slot guides close to the chassis lid. (See C.) Do not allow the port adapter components to come in contact with the system board or the port adapter could be damaged.

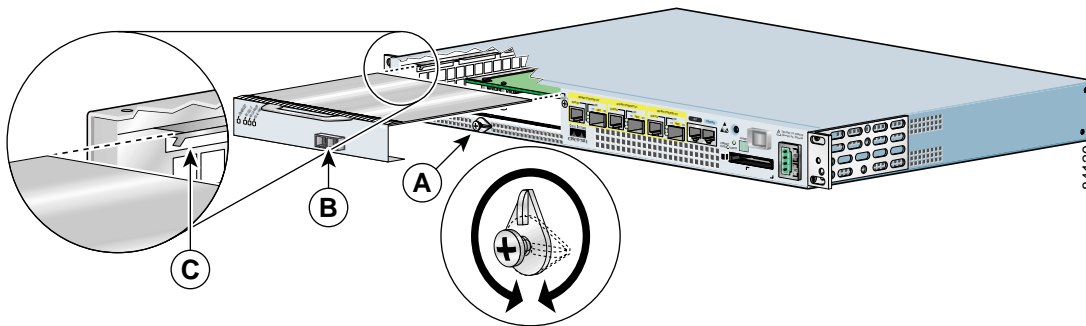

Step 5

To insert the port adapter, carefully align the port adapter carrier in the slot guides. (See C.) Slide the new port adapter halfway into the chassis.

Step 6

Connect all required cables to the port adapter. After connecting all required cables, carefully slide the port adapter all the way into the slot until the port adapter is seated in the midplane.

Step 7

After the port adapter is properly seated, turn and secure the port adapter latch in the upright, locked position. (See A.) Tighten the screw to ensure the port adapter remains firmly in place.

Cisco 7304 PCI Port Adapter Carrier Card—Removing and Installing a Port Adapter

You can install one single-width port adapter in a Cisco 7304 PCI Port Adapter Carrier Card. This section provides step-by-step instructions for removing and installing a port adapter in a Cisco 7304 PCI Port Adapter Carrier Card.



Warning

When performing the following procedures, wear a grounding wrist strap to avoid ESD damage to the Cisco 7304 PCI Port Adapter Carrier Card. Some platforms have an ESD connector for attaching the wrist strap. Do not directly touch the midplane or backplane with your hand or any metal tool, or you could shock yourself.

To remove and install a port adapter in a Cisco 7304 PCI Port Adapter Carrier Card, refer to [Figure 3-2](#) and do the following:

- Step 1** If the Cisco 7304 PCI Port Adapter Carrier Card is still in the router, you must remove the Cisco 7304 PCI Port Adapter Carrier Card before removing a port adapter.
- Step 2** To remove the port adapter from the Cisco 7304 PCI Port Adapter Carrier Card, turn the port adapter lock from its locked and horizontal position shown in A of [Figure 3-2](#) to its unlocked and vertical position shown in B of [Figure 3-2](#).
- Step 3** Grasp the handle of the port adapter and pull the port adapter from the Cisco 7304 PCI Port Adapter Carrier Card. (You have already disconnected the cables from the port adapter when removing the Cisco 7304 PCI Port Adapter Carrier Card).
- Step 4** To insert the port adapter in the Cisco 7304 PCI Port Adapter Carrier Card, locate the guide rails inside the Cisco 7304 PCI Port Adapter Carrier Card that hold the port adapter in place. They are at the top left and top right of the port adapter slot and are recessed about an inch, as shown in C of [Figure 3-2](#).
- Step 5** Carefully slide the port adapter in the Cisco 7304 PCI Port Adapter Carrier Card until the port adapter makes contact with the port adapter interface connector. When fully seated, the port adapter front panel should be flush with the face of the Cisco 7304 PCI Port Adapter Carrier Card.
- Step 6** After the port adapter is properly seated, turn the port adapter lock to its locked and horizontal position, as shown in A of [Figure 3-2](#).

Figure 3-2 illustrates how to remove and install a port adapter in a Cisco 7304 PCI Port Adapter Carrier Card.

Figure 3-2 Cisco 7304 PCI Port Adapter Carrier Card—Port Adapter Removal and Installation

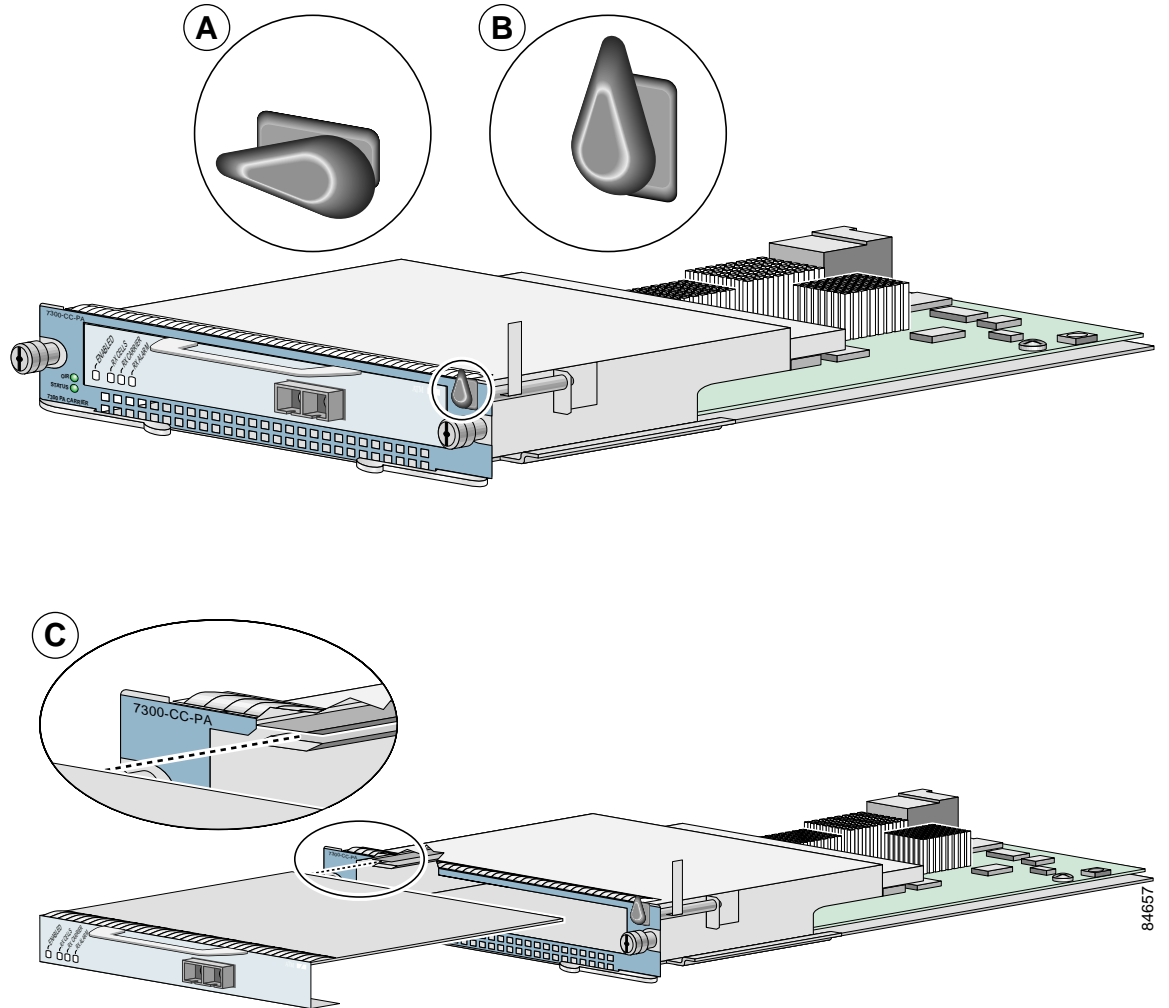

Cisco 7401ASR Router—Removing and Installing a Port Adapter

Step 1

To remove the port adapter, use a number 2 Phillips screwdriver to loosen the screw on the port adapter latch. Rotate the port adapter latch until it clears the faceplate of the port adapter. (See A.) The latch can rotate 360°.

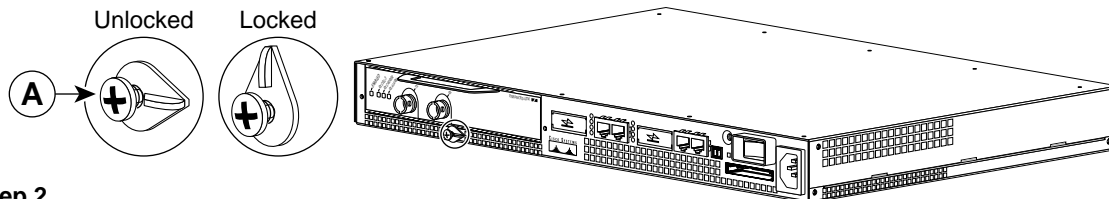

Step 2

Pull the port adapter from the router, about halfway out of its slot. (If you remove a blank port adapter, keep the blank port adapter for use in the router if you should ever remove the port adapter. The port adapter slot must always be filled.)

Step 3

With the port adapter halfway out of the slot, disconnect all cables from the port adapter. After disconnecting the cables, pull the port adapter completely out of the chassis slot.

Step 4

To insert the port adapter, locate the port adapter slot guides inside the Cisco 7401ASR router. They are near the top, and are recessed about 1/2 inch. (See B.)

Caution

The port adapter must slide into the slot guides under the chassis lid. Do not allow the port adapter components to come in contact with the system board, or the port adapter could be damaged.

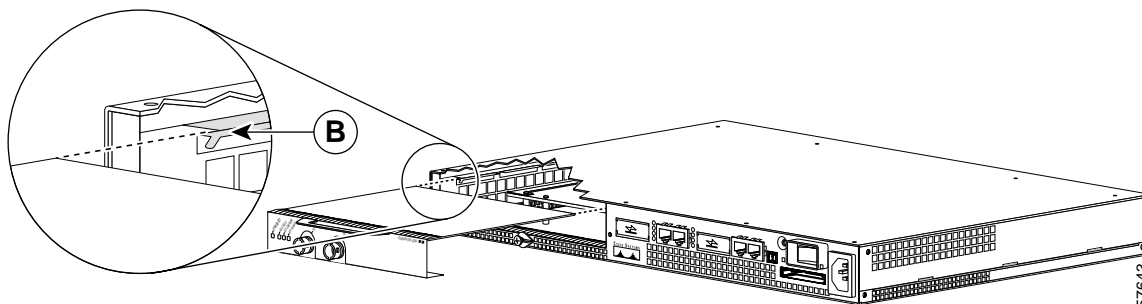

Step 5

Insert the port adapter in the slot guides halfway, and then reconnect the port adapter cables.

Step 6

After the cables are connected, carefully slide the port adapter all the way into the slot until the port adapter is seated in the router midplane. When installed, the port adapter input/output panel should be flush with the face of the router.

Step 7

After the port adapter is properly seated, rotate the port adapter latch to the upright locked position and use a number 2 Phillips screwdriver to tighten the latch screw. If needed, loosen the latch screw to rotate the latch over the port adapter. Finish the installation by tightening the latch screw.

VIP—Removing and Installing a Port Adapter

Note: You must first remove the VIP from the chassis before removing a port adapter from the VIP.

Step 1

To remove the port adapter, remove the screw that secures the port adapter (or blank port adapter). (See A.)

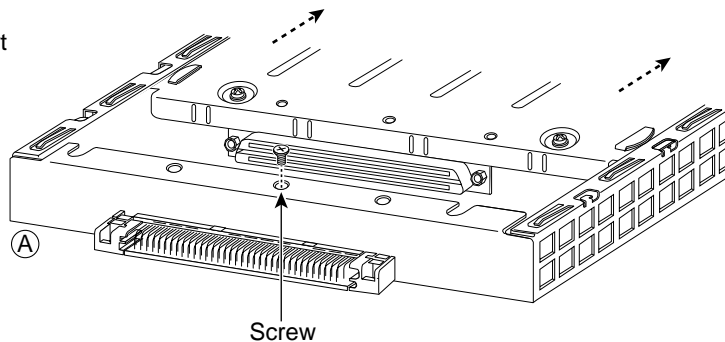

Step 2

With the screw removed, grasp the handle on the front of the port adapter (or blank port adapter) and carefully pull it out of its slot, away from the edge connector at the rear of the slot. (See A.)

Step 3

To insert the port adapter, carefully align the port adapter carrier between the upper and the lower edges of the port adapter slot. (See B.)

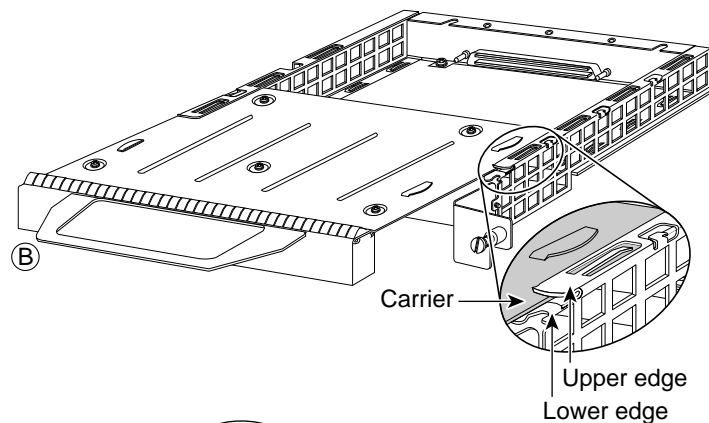

Step 4

Carefully slide the new port adapter into the port adapter slot until the connector on the port adapter is completely seated in the connector at the rear of the port adapter slot. (See B.)

Step 5

Install the screw in the rear of the port adapter slot on the VIP. Do not overtighten the screw. (See A.)

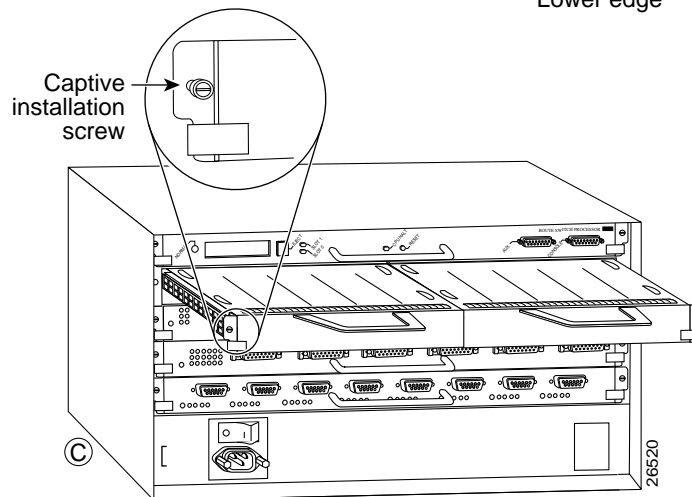

Step 6

Carefully slide the VIP motherboard into the interface processor slot until the connectors at the rear of the VIP are completely seated in the connectors at the rear of the interface processor slot. Use the ejector levers to seat the VIP in the interface processor slot. Tighten the captive installation screws on the VIP. (See C.)



Attaching the PA-8T-X21 Interface Cables

To continue your Cisco PA-8T-X21 synchronous serial port adapter installation, you must install the port adapter cables. The instructions that follow apply to all supported platforms. This chapter contains the following sections:

- [Connecting a PA-8T-X21 Compact Serial Cable, page 4-1](#)
- [Determining the Port Mode, page 4-3](#)

Connecting a PA-8T-X21 Compact Serial Cable

On a single PA-8T-X21, you can use only one compact serial cable. PA-8T-X21 compact serial cables are available *only* from Cisco Systems; they are *not* available from commercial cable vendors.



Caution

Only attach an X.21 compact serial cable to the PA-8T-X21 installed in your router. Attaching a compact serial cable of another interface type to the port adapter could damage your router or the hardware at the network end of the cable.

Use the following procedure to connect a compact serial cable to a PA-8T-X21:

Step 1

Attach the compact serial cable directly to the receptacle on the PA-8T-X21 and tighten the strain-relief screws. (See [Figure 4-1 on page 4-2](#).)



Note

Port adapters have a handle attached, but this handle is not shown to allow a full detailed view of each port adapter's faceplate.

When attaching the cable receptacle on the PA-8T-X21, use the cable-management bracket that shipped with your router for extra strain relief.

Figure 4-1 Connecting a PA-8T-X21 Compact Serial Cable—Front View (Shown without Handle)

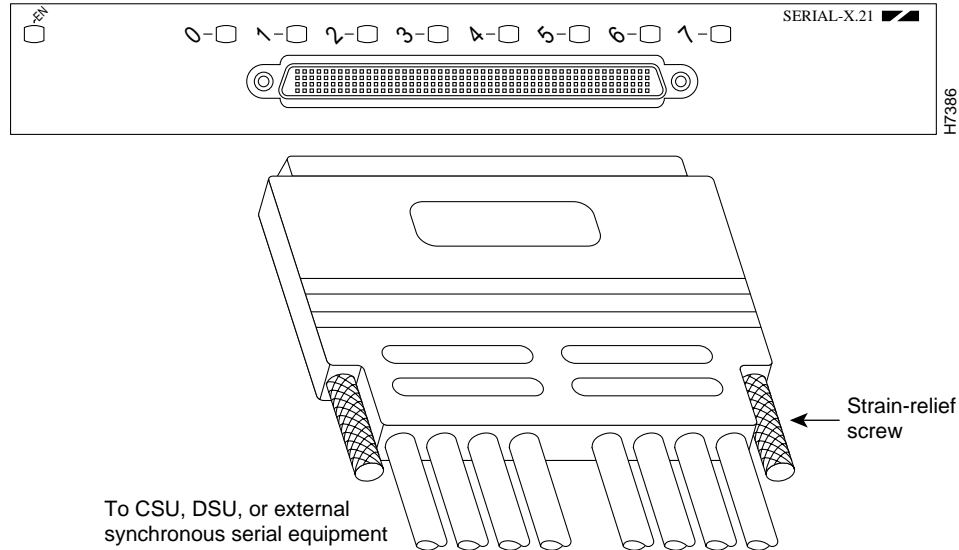
**Caution**

Compact serial cables must be attached correctly or damage to the cable plug will result. Attempting to force a cable plug on the 200-pin receptacle can damage the plug. (See [Figure 4-2.](#))

Figure 4-2 Connecting the Compact Serial Cable

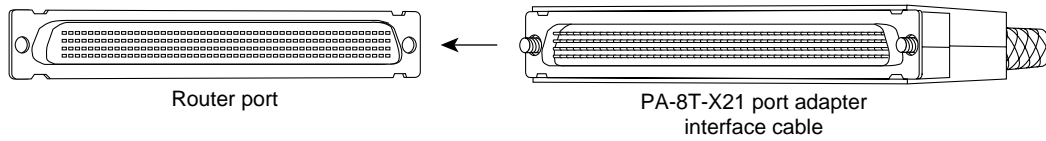
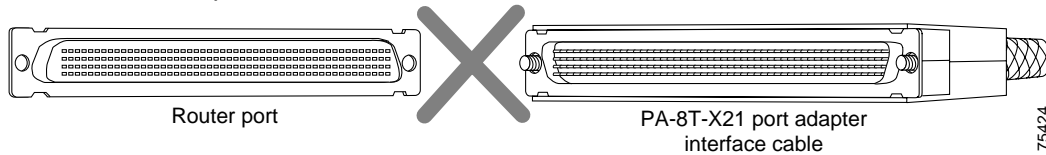
Correct**Incorrect, cable upside down**

- Step 2** Attach the network end of your serial cable to your data service unit (DSU), channel service unit (CSU), data terminal equipment (DTE), or other external synchronous-serial equipment and tighten the strain-relief screws.

This completes the procedure for attaching a PA-8T-X21 compact serial cable to the PA-8T-X21. If you need to replace a PA-8T-X21 compact serial cable, proceed to the [“Determining the Port Mode”](#) section on page 4-3; otherwise, proceed to [Chapter 5, “Configuring the PA-8T-X21 Interfaces.”](#)

Determining the Port Mode

The compact serial cable connected to each port determines the mode of the ports (the electrical interface type is always X21). The default mode of the ports is data communication equipment (DCE), which allows you to perform a loopback test on any port without having to attach a port adapter cable. For information related to the **loopback** command, see the “Using loopback Commands” section on page 5-28. Although DCE is the default, there is no default clock rate set on the interfaces. On Cisco 7100 series, Cisco 7200 series, Cisco uBR7200 series routers, Cisco 7301 router, or Cisco 7401ASR routers when there is no cable attached to a port, the software actually identifies the port as *cable type: None present* rather than either a DTE or DCE interface. On a Cisco 7304 PCI Port Adapter Carrier Card, Catalyst RSM/VIP2, Catalyst 6000 family FlexWAN module, or VIP when there is no cable attached to a port, the software actually identifies the port as *Universal (cable unattached)* rather than either a DTE or DCE interface.



Caution

You can attach only an EIA/TIA-X.21 compact serial cable to the PA-8T-X21 installed in your router. Attaching a compact serial cable of another interface type to the port adapter could damage your router or the hardware at the network end of the cable.

Following is an example of the **show controllers cbus** command that shows a Cisco 7100 series router, Cisco 7200 series router, Cisco uBR7200 series router, or Cisco 7401ASR router interface port (1/0) that has an X.21 DTE cable attached:

```
Router# show controllers serial 1/0

M8T-X.21: show controllers:
PAS unit 0, subunit 0, f/w version 1-19, Rev id 0x2800001, version 2
idb = 0x60942688, ds = 0x608A6570, ssb=0x608C6CF0
Clock mux=0x0, ucmd_ctrl=0x1C, port_status=0xC
maxdgram=1524, bufpool=32Kb, 64 particles
      DCD=up DSR=up DTR=down RTS=down CTS=up
line state: down
cable type : X.21 DCE cable, received clockrate 123984
[display text omitted]
```

Following is an example of the **show controllers cbus** command that shows a VIP interface port (2/1/0) that has an X.21 DTE cable attached:

```
Router# show controllers cbus

slot2: VIP2, hw 2.2, sw 21.40, ccb 5800FFA0, cmdq 480000C0, vps 8192
software loaded from flash slot0:muck/amcrae/vip2_21-40.mxt
FLASH ROM version 255.255
Mueslix Serial(8), HW Revision 0x1, FW Revision 1.20
Serial2/1/0, applique is X.21 DTE
  gfreeq 48000140, lfreeq 480001B0 (1536 bytes), throttled 0
  rxlo 4, rxhi 90, rxcurr 0, maxrxcurr 0
txq 48001A80, txacc 48001A82 (value 58), txlimit 58
[display text omitted]
```

Following is an example of the **show controllers cbus** command that shows a Catalyst RSM/VIP2 interface port (1/0) that has an X.21 DTE cable attached:

```
Router# show controllers cbus

slot2: VIP2, hw 2.2, sw 21.40, ccb 5800FFA0, cmdq 480000C0, vps 8192
software loaded from flash slot0:muck/amcrae/vip2_21-40.mxt
FLASH ROM version 255.255
Mueslix Serial(8), HW Revision 0x1, FW Revision 1.20
```

```
Serial1/0, applique is X.21 DTE
  gfreeq 48000140, lfreeq 480001B0 (1536 bytes), throttled 0
  rxlo 4, rxhi 90, rxcurr 0, maxrxcurr 0
txq 48001A80, txacc 48001A82 (value 58), txlimit 58
[display text omitted]
```

**Note**

The slot values displayed by some commands (such as **show diag** and **show cont cbus**) are not relevant to any physical connection; disregard these slot values for the Catalyst RSM/VIP2.

To change the mode of a port online, use software commands to shut down the interface, replace the compact serial cable, restart the interface and, if necessary, reconfigure the port for the new interface. At system startup or restart, the system polls the interfaces and determines the electrical interface type of each port (according to the type of compact serial cable attached). However, the system does not necessarily re poll an interface when you change the adapter cable online. To ensure that the system recognizes the new interface type, shut down and re enable the interface after changing the cable.

If you are replacing a cable with a cable that has the same mode, these steps are not necessary (simply replace the cable without interrupting operation).

- Step 1** Enter configuration mode and at the privileged level of the EXEC, specify the port address, shut down the interface, and write the configuration to nonvolatile random-access memory (NVRAM). (See the [“Using the EXEC Command Interpreter”](#) section on page 5-1, for an explanation of the privileged level of the EXEC.) Add additional configuration commands, if needed, before you exit from configuration mode (before you press **Ctrl-Z** or enter **end**).

For Cisco 7200 series, Cisco uBR7200 series, Cisco 7100 series routers, Cisco 7301 router, or Cisco 7401ASR routers use the following example:

```
Router> enable
Password:
Router# configure terminal
Enter configuration commands, one per line. End with CNTL/Z.
Router(config)# interface serial 1/0
Router(config-if)# shutdown
Ctrl-Z
Router#
```

For a VIP, use the following example:

```
Router> enable
Password:
Router# configure terminal
Enter configuration commands, one per line. End with CNTL/Z.
Router(config)# interface serial 3/1/0
Router(config-if)# shutdown
Ctrl-Z
Router#
```

For a Catalyst RSM/VIP2, use the following example:

```
Router> enable
Password:
Router# configure terminal
Enter configuration commands, one per line. End with CNTL/Z.
Router(config)# interface serial 1/0
Router(config-if)# shutdown
Ctrl-Z
Router#
```

- Step 2** Locate and remove the adapter cable to be replaced.

- Step 3** Connect the new cable between the PA-8T-X21 and the network connection. Tighten the thumbscrews at both ends of the cable to secure it in the ports.
- Step 4** Enter configuration mode again, bring the port back up, and save the running configuration to NVRAM.
-

For Cisco 7100 series, Cisco 7200 series, Cisco uBR7200 series routers, Cisco 7301 router, or Cisco 7401ASR routers use the following example:

```
Router# configure terminal
Enter configuration commands, one per line. End with CNTL/Z.
Router(config)# interface serial 1/0
Router(config-if)# no shutdown
Ctrl-Z
Router#

Router# copy running-config startup-config
```

For a VIP, use the following example:

```
Router# configure terminal
Enter configuration commands, one per line. End with CNTL/Z.
Router(config)# interface serial 3/1/0
Router(config-if)# no shutdown
Ctrl-Z
Router#

Router# copy running-config startup-config
```

For a Catalyst RSM/VIP2, use the following example:

```
Router# configure terminal
Enter configuration commands, one per line. End with CNTL/Z.
Router(config)# interface serial 1/0
Router(config-if)# no shutdown
Ctrl-Z
Router#

Router# copy running-config startup-config
```

These steps will prompt the system to poll the interface and recognize the new interface immediately.

When you configure a port for a DCE interface for the first time, or when you set up a loopback test, you must set the clock rate for the port. When you connect a DCE cable to a port, the interface remains down, and the interface does not function until you set a clock rate (regardless of the DCE mode default).

If you are changing the mode of the interface from DCE to DTE, you do not need to change the clock rate for the port. After you replace the DCE cable with a DTE cable, and the system recognizes the interface as a DTE, it uses the external clock signal from the remote DCE device and ignores the internal clock signal that the DCE interface normally uses. Therefore, when you configure the clock rate on a port for either a DCE interface or loopback, you can leave the clock rate configured and still use that port as a DTE interface.

This completes the procedure for replacing a PA-8T-X21 compact serial cable on the PA-8T-X21. Proceed to [Chapter 5, “Configuring the PA-8T-X21 Interfaces,”](#) to configure your port adapter.



Configuring the PA-8T-X21 Interfaces

To continue your Cisco PA-8T-X21 synchronous serial port adapter installation, you must configure the PA-8T-X21 interfaces. The instructions that follow apply to all supported platforms. Minor differences between the platforms are noted. This chapter contains the following sections:

- [Using the EXEC Command Interpreter, page 5-1](#)
- [Configuring the Interfaces, page 5-2](#)
- [Configuring Half-Duplex and Binary Synchronous Communications, page 5-15](#)
- [Checking the Configuration, page 5-17](#)

Using the EXEC Command Interpreter

You modify the configuration of your router through the software command interpreter called the *EXEC*. You must enter the privileged level of the EXEC command interpreter (also called enable mode) with the **enable** command before you can use the **configure** command to configure a new interface or to change the existing configuration of an interface. The system prompts you for a password if one has been set.

The system prompt for the privileged level ends with a pound sign (#) instead of an angle bracket (>). At the console terminal, use the following procedure to enter the privileged level:

-
- Step 1** At the user-level EXEC prompt, enter the **enable** command. The EXEC prompts you for a privileged-level password as follows:

```
Router> enable
```

```
Password:
```

- Step 2** Enter the password (the password is case-sensitive). For security purposes, the password is not displayed.

When you enter the correct password, the system displays the privileged-level system prompt (#):

```
Router#
```

Configuring the Interfaces

After you verify that the new PA-8T-X21 is installed correctly (the enabled LED goes on), use the privileged-level **configure** command to configure the new interfaces. Have this information available:

- Protocols you plan to route on each new interface
- IP addresses if you will configure the interfaces for IP routing
- A decision about the use of bridging on the new interface
- Timing source for each new interface and clock speeds for external timing

If you installed a new PA-8T-X21 or if you want to change the configuration of an existing interface, you must enter configuration mode to configure the new interfaces. If you replaced a PA-8T-X21 that was previously configured, the system will recognize the new PA-8T-X21 interfaces and brings each of them up in their existing configuration.

For a summary of the configuration options available and instructions for configuring interfaces on a PA-8T-X21, refer to the appropriate configuration publications listed in the [“Related Documentation” section on page viii](#).

You execute configuration commands from the privileged level of the EXEC command interpreter, which usually requires password access. Contact your system administrator, if necessary, to obtain password access. (See the [“Using the EXEC Command Interpreter” section on page 5-1](#) for an explanation of the privileged level of the EXEC.)

This section contains the following subsections:

- [Shutting Down an Interface, page 5-2](#)
- [Performing a Basic Configuration, page 5-8](#)
- [Configuring Timing \(Clock\) Signals, page 5-10](#)
- [Configuring NRZI Format, page 5-13](#)
- [Configuring Cyclic Redundancy Checks, page 5-14](#)

Shutting Down an Interface

Before you remove an interface that you will not replace, replace a compact serial cable, or replace port adapters, use the **shutdown** command to shut down (disable) the interfaces to prevent anomalies when you reinstall the new or re configured interface processor. When you shut down an interface, it is designated *administratively down* in the **show** command displays.

Follow these steps to shut down an interface:

-
- Step 1** Enter the privileged level of the EXEC command interpreter (also called enable mode). (See the [“Using the EXEC Command Interpreter” section on page 5-1](#) for instructions.)
- Step 2** At the privileged-level prompt, enter configuration mode and specify that the console terminal is the source of the configuration subcommands, as follows:
- ```
Router# configure terminal
Enter configuration commands, one per line. End with CNTL/Z.
Router(config)#
```
- Step 3** Shut down interfaces by entering the **interface serial** sub command (followed by the interface address of the interface) and then enter the **shutdown** command. [Table 5-1](#) shows the command syntax.

When you are done, press **Ctrl-Z** (hold down the **Control** key while you press **Z**) or enter **end** or **exit** to exit configuration mode and return to the EXEC command interpreter.

**Table 5-1** Syntax of the shutdown Command

| Platform                                                             | Command                                                                                                                                                | Example                                                                                                                                                                                                                                                                                                                                                |
|----------------------------------------------------------------------|--------------------------------------------------------------------------------------------------------------------------------------------------------|--------------------------------------------------------------------------------------------------------------------------------------------------------------------------------------------------------------------------------------------------------------------------------------------------------------------------------------------------------|
| Catalyst RSM/VIP2 in Catalyst 5000 family switches                   | <b>interface</b> , followed by the <i>type (serial)</i> and <i>slot/port</i> (port-adapter-slot-number/interface-port-number)                          | The example is for interface 0 and interface 1 on a port adapter in port adapter slot 1.<br><br><pre>Router(config-if)# <b>interface serial 1/0</b> Router(config-if)# <b>shutdown</b> Router(config-if)# <b>interface serial 1/1</b> Router(config-if)# <b>shutdown</b> <b>Ctrl-Z</b> Router#</pre>                                                   |
| Catalyst 6000 family FlexWAN module in Catalyst 6000 family switches | <b>interface</b> , followed by the <i>type (serial)</i> and <i>mod_num/bay/port</i> (module-slot-number/port-adapter-bay-number/interface-port-number) | The example is for interface 0 and interface 1 on a port adapter in port adapter bay 0 of a FlexWAN module installed in module slot 3.<br><br><pre>Router(config-if)# <b>interface serial 3/0/0</b> Router(config-if)# <b>shutdown</b> Router(config-if)# <b>interface serial 3/0/1</b> Router(config-if)# <b>shutdown</b> <b>Ctrl-Z</b> Router#</pre> |
| Cisco 7120 series routers                                            | <b>interface</b> , followed by the <i>type (serial)</i> and <i>slot/port</i> (port-adapter-slot-number/interface-port-number)                          | The example is for interface 0 and interface 1 on a port adapter in port adapter slot 3.<br><br><pre>Router(config-if)# <b>interface serial 3/0</b> Router(config-if)# <b>shutdown</b> Router(config-if)# <b>interface serial 3/1</b> Router(config-if)# <b>shutdown</b> <b>Ctrl-Z</b> Router#</pre>                                                   |
| Cisco 7140 series routers                                            | <b>interface</b> , followed by the <i>type (serial)</i> and <i>slot/port</i> (port-adapter-slot-number/interface-port-number)                          | The example is for interface 0 and interface 1 on a port adapter in port adapter slot 4.<br><br><pre>Router(config-if)# <b>interface serial 4/0</b> Router(config-if)# <b>shutdown</b> Router(config-if)# <b>interface serial 4/1</b> Router(config-if)# <b>shutdown</b> <b>Ctrl-Z</b> Router#</pre>                                                   |
| Cisco 7200 series routers                                            | <b>interface</b> , followed by the <i>type (serial)</i> and <i>slot/port</i> (port-adapter-slot-number/interface-port-number)                          | The example is for interface 0 and interface 1 on a port adapter in port adapter slot 6.<br><br><pre>Router(config-if)# <b>interface serial 6/0</b> Router(config-if)# <b>shutdown</b> Router(config-if)# <b>interface serial 6/1</b> Router(config-if)# <b>shutdown</b> <b>Ctrl-Z</b> Router#</pre>                                                   |

Table 5-1 Syntax of the shutdown Command (continued)

| Platform                                                        | Command                                                                                                                                                                    | Example                                                                                                                                                                                                                                                                                                                                                         |
|-----------------------------------------------------------------|----------------------------------------------------------------------------------------------------------------------------------------------------------------------------|-----------------------------------------------------------------------------------------------------------------------------------------------------------------------------------------------------------------------------------------------------------------------------------------------------------------------------------------------------------------|
| Cisco uBR7223 router                                            | <b>interface</b> , followed by the <i>type (serial)</i> and <i>slot/port</i> (port-adapter-slot-number/interface-port-number)                                              | The example is for interface 0 and interface 1 on a port adapter in port adapter slot 1.<br><pre>Router(config-if)# <b>interface serial 1/0</b> Router(config-if)# <b>shutdown</b> Router(config-if)# <b>interface serial 1/1</b> Router(config-if)# <b>shutdown</b> <b>Ctrl-Z</b> Router#</pre>                                                                |
| Cisco uBR7246 router                                            | <b>interface</b> , followed by the <i>type (serial)</i> and <i>slot/port</i> (port-adapter-slot-number/interface-port-number)                                              | The example is for interface 0 and interface 1 on a port adapter in port adapter slot 2.<br><pre>Router(config-if)# <b>interface serial 2/0</b> Router(config-if)# <b>shutdown</b> Router(config-if)# <b>interface serial 2/1</b> Router(config-if)# <b>shutdown</b> <b>Ctrl-Z</b> Router#</pre>                                                                |
| Cisco 7301 routers                                              | <b>interface</b> , followed by the <i>type (serial)</i> and <i>slot/port</i> (port-adapter-slot-number/interface-port-number)                                              | The example is for interface 0 and interface 1 on a port adapter in port adapter slot 1.<br><pre>Router(config-if)# <b>interface serial 1/0</b> Router(config-if)# <b>shutdown</b> Router(config-if)# <b>interface serial 1/1</b> Router(config-if)# <b>shutdown</b> <b>Ctrl-Z</b> Router#</pre>                                                                |
| Cisco 7304 PCI Port Adapter Carrier Card in a Cisco 7304 router | <b>interface</b> , followed by the <i>type (serial)</i> and <i>slot/port</i> (module-slot-number/interface-port-number)                                                    | The example is for interface 0 and interface 1 on a port adapter in a Cisco 7304 PCI Port Adapter Carrier Card in module slot 3 of a Cisco 7304 router.<br><pre>Router(config-if)# <b>interface serial 3/0</b> Router(config-if)# <b>shutdown</b> Router(config-if)# <b>interface serial 3/1</b> Router(config-if)# <b>shutdown</b> <b>Ctrl-Z</b> Router#</pre> |
| Cisco 7401ASR routers                                           | <b>interface</b> , followed by the <i>type (serial)</i> and <i>slot/port</i> (port-adapter-slot-number/interface-port-number)                                              | The example is for interface 0 and interface 1 on a port adapter in port adapter slot 1.<br><pre>Router(config-if)# <b>interface serial 1/0</b> Router(config-if)# <b>shutdown</b> Router(config-if)# <b>interface serial 1/1</b> Router(config-if)# <b>shutdown</b> <b>Ctrl-Z</b> Router#</pre>                                                                |
| VIP in Cisco 7000 series or Cisco 7500 series routers           | <b>interface</b> , followed by the <i>type (serial)</i> and <i>slot/port adapter/port</i> (interface-processor-slot-number/port-adapter-slot-number/interface-port-number) | The example is for interface 1 and interface 0 on a port adapter in port adapter slot 1 of a VIP installed in interface processor slot 1.<br><pre>Router(config-if)# <b>interface serial 1/1/1</b> Router(config-if)# <b>shutdown</b> Router(config-if)# <b>interface serial 1/1/0</b> Router(config-if)# <b>shutdown</b> <b>Ctrl-Z</b> Router#</pre>           |



**Note** If you need to shut down additional interfaces, enter the **interface serial** command (followed by the interface address of the interface) for each of the interfaces on your port adapter. Use the **no shutdown** command to enable the interface.

**Step 4** Write the new configuration to NVRAM as follows:

```
Router# copy running-config startup-config
[OK]
Router#
```

The system displays an OK message when the configuration has been stored in NVRAM.

**Step 5** Verify that new interfaces are now in the correct state (shutdown) using the **show interfaces serial** command (followed by the interface address of the interface) to display the specific interface. [Table 5-2](#) provides examples.

**Table 5-2** Examples of the *show interfaces* Command

| Platform                                                             | Command                                                                                                                                | Example                                                                                                                                                                                                                                                                                           |
|----------------------------------------------------------------------|----------------------------------------------------------------------------------------------------------------------------------------|---------------------------------------------------------------------------------------------------------------------------------------------------------------------------------------------------------------------------------------------------------------------------------------------------|
| Catalyst RSM/VIP2 in Catalyst 5000 family switches                   | <b>show interfaces serial</b> , followed by <i>slot/port</i> (port-adapter-slot-number/interface-port-number)                          | The example is for interface 0 on a port adapter in port adapter slot 1.<br><br>Router# <b>show interfaces serial 1/0</b><br><br>Serial 1/0 is administratively down,<br>line protocol is down<br><br>[Additional display text omitted from this example]                                         |
| Catalyst 6000 family FlexWAN module in Catalyst 6000 family switches | <b>show interfaces serial</b> , followed by <i>mod_num/bay/port</i> (module-slot-number/port-adapter-bay-number/interface-port-number) | The example is for interface 0 on a port adapter in port adapter bay 0 of a FlexWAN module in module slot 3.<br><br>Router# <b>show interfaces serial 3/0/0</b><br><br>Serial 3/0/0 is administratively down,<br>line protocol is down<br><br>[Additional display text omitted from this example] |
| Cisco 7120 series routers                                            | <b>show interfaces serial</b> , followed by <i>slot/port</i> (port-adapter-slot-number/interface-port-number)                          | The example is for interface 0 on a port adapter in port adapter slot 3.<br><br>Router# <b>show interfaces serial 3/0</b><br><br>Serial 3/0 is administratively down,<br>line protocol is down<br><br>[Additional display text omitted from this example]                                         |

Table 5-2 Examples of the show interfaces Command (continued)

| Platform                  | Command                                                                                                              | Example                                                                                                                                                                                                                                                      |
|---------------------------|----------------------------------------------------------------------------------------------------------------------|--------------------------------------------------------------------------------------------------------------------------------------------------------------------------------------------------------------------------------------------------------------|
| Cisco 7140 series routers | <b>show interfaces serial</b> , followed by <i>slot/port</i><br>(port-adapter-slot-number/<br>interface-port-number) | The example is for interface 0 on a port adapter in port adapter slot 4.<br><br>Router# <b>show interfaces serial 4/0</b><br><br>Serial 4/0 is administratively down,<br>line protocol is down<br><br>[Additional display text omitted from<br>this example] |
| Cisco 7200 series routers | <b>show interfaces serial</b> , followed by <i>slot/port</i><br>(port-adapter-slot-number/<br>interface-port-number) | The example is for interface 0 on a port adapter in port adapter slot 6.<br><br>Router# <b>show interfaces serial 6/0</b><br><br>Serial 6/0 is administratively down,<br>line protocol is down<br><br>[Additional display text omitted from<br>this example] |
| Cisco uBR7223 router      | <b>show interfaces serial</b> , followed by <i>slot/port</i> (port-adapter-slot-number/<br>interface-port-number)    | The example is for interface 0 on a port adapter in port adapter slot 1.<br><br>Router# <b>show interfaces serial 1/0</b><br><br>Serial 1/0 is administratively down,<br>line protocol is down<br><br>[Additional display text omitted from<br>this example] |
| Cisco uBR7246 router      | <b>show interfaces serial</b> , followed by <i>slot/port</i><br>(port-adapter-slot-number/<br>interface-port-number) | The example is for interface 0 on a port adapter in port adapter slot 2.<br><br>Router# <b>show interfaces serial 2/0</b><br><br>Serial 2/0 is administratively down,<br>line protocol is down<br><br>[Additional display text omitted from<br>this example] |
| Cisco 7301 routers        | <b>show interfaces serial</b> , followed by <i>slot/port</i><br>(port-adapter-slot-number/<br>interface-port-number) | The example is for interface 0 on a port adapter in port adapter slot 1.<br><br>Router# <b>show interfaces serial 1/0</b><br><br>Serial 1/0 is administratively down,<br>line protocol is down<br><br>[Additional display text omitted from<br>this example] |

Table 5-2 Examples of the `show interfaces` Command (continued)

| Platform                                                        | Command                                                                                                                                                    | Example                                                                                                                                                                                                                                                                                                                  |
|-----------------------------------------------------------------|------------------------------------------------------------------------------------------------------------------------------------------------------------|--------------------------------------------------------------------------------------------------------------------------------------------------------------------------------------------------------------------------------------------------------------------------------------------------------------------------|
| Cisco 7304 PCI Port Adapter Carrier Card in a Cisco 7304 router | <b>show interfaces serial</b> , followed by <i>slot/port</i> (module-slot-number/interface-port-number)                                                    | The example is for interface 0 on a port adapter in a Cisco 7304 PCI Port Adapter Carrier Card in module slot 3 of a Cisco 7304 router.<br><br>Router# <b>show interfaces serial 3/0</b><br><br>Serial 3/0 is administratively down,<br>line protocol is down<br><br>[Additional display text omitted from this example] |
| Cisco 7401ASR routers                                           | <b>show interfaces serial</b> , followed by <i>slot/port</i> (port-adapter-slot-number/interface-port-number)                                              | The example is for interface 0 on a port adapter in port adapter slot 1.<br><br>Router# <b>show interfaces serial 1/0</b><br><br>Serial 1/0 is administratively down,<br>line protocol is down<br><br>[Additional display text omitted from this example]                                                                |
| VIP in Cisco 7000 series or Cisco 7500 series routers           | <b>show interfaces serial</b> , followed by <i>slot/port adapter/port</i> (interface-processor-slot-number/port-adapter-slot-number/interface-port-number) | The example is for interface 0 on a port adapter in port adapter slot 1 of a VIP in interface processor slot 1.<br><br>Router# <b>show interfaces serial 1/1/0</b><br><br>Serial 1/1/0 is administratively down,<br>line protocol is down<br><br>[Additional display text omitted from this example]                     |

- Step 6** Re enable interfaces by doing the following:
- a. Repeat Step 3 to re enable an interface. Substitute the **no shutdown** command for the **shutdown** command.
  - b. Repeat Step 4 to write the new configuration to memory. Use the **copy running-config startup-config** command.
  - c. Repeat Step 5 to verify that the interfaces are in the correct state. Use the **show interfaces serial** command followed by the interface address of the interface.

For complete descriptions of software configuration commands, refer to the publications listed in the “[Related Documentation](#)” section on page viii.

## Performing a Basic Configuration

Following are instructions for a basic configuration: enabling an interface, specifying IP routing, and setting up external timing on a DCE interface. You might also need to enter other configuration subcommands, depending on the requirements for your system configuration and the protocols you plan to route on the interface. For complete descriptions of configuration subcommands and the configuration options available for serial interfaces, refer to the appropriate software documentation.

In the following procedure, press the **Return** key after each step unless otherwise noted. At any time you can exit the privileged level and return to the user level by entering **disable** at the prompt as follows:

```
Router# disable
```

```
Router>
```

- Step 1** Enter configuration mode and specify that the console terminal is the source of the configuration subcommands as follows:

```
Router# configure terminal
Enter configuration commands, one per line. End with CNTL/Z.
Router(config)#
```

- Step 2** Specify the first interface to configure by entering the **interface serial** sub command, followed by the interface address of the interface you plan to configure. [Table 5-3](#) provides examples.

**Table 5-3** Examples of the interface serial Subcommands

| Platform                                                             | Command                                                                                                                                     | Example                                                                                                                                                                                 |
|----------------------------------------------------------------------|---------------------------------------------------------------------------------------------------------------------------------------------|-----------------------------------------------------------------------------------------------------------------------------------------------------------------------------------------|
| Catalyst RSM/VIP2 in Catalyst 5000 family switches                   | <b>interface serial</b> , followed by <i>slot/port</i><br>(port-adapter-slot-number/<br>interface-port-number)                              | The example is for interface 0 of a port adapter in port adapter slot 0.<br><br>Router(config)# <b>interface serial</b> 0/0<br>Router(config-if)#                                       |
| Catalyst 6000 family FlexWAN module in Catalyst 6000 family switches | <b>interface serial</b> , followed by <i>mod_num/bay/port</i><br>(module-slot-number/<br>port-adapter-bay-number/<br>interface-port-number) | The example is for interface 0 of a port adapter in port adapter bay 0 of a FlexWAN module in module slot 3.<br><br>Router(config)# <b>interface serial</b> 3/0/0<br>Router(config-if)# |
| Cisco 7120 series routers                                            | <b>interface serial</b> , followed by <i>slot/port</i><br>(port-adapter-slot-number/<br>interface-port-number)                              | The example is for interface 0 of a port adapter in port adapter slot 3.<br><br>Router(config)# <b>interface serial</b> 3/0<br>Router(config-if)#                                       |
| Cisco 7140 series routers                                            | <b>interface serial</b> , followed by <i>slot/port</i><br>(port-adapter-slot-number/<br>interface-port-number)                              | The example is for interface 0 of a port adapter in port adapter slot 4.<br><br>Router(config)# <b>interface serial</b> 4/0<br>Router(config-if)#                                       |
| Cisco 7200 series routers                                            | <b>interface serial</b> , followed by <i>slot/port</i><br>(port-adapter-slot-number/<br>interface-port-number)                              | The example is for interface 0 of a port adapter in port adapter slot 6.<br><br>Router(config)# <b>interface serial</b> 6/0<br>Router(config-if)#                                       |



Table 5-3 Examples of the interface serial Subcommands (continued)

| Platform                                                        | Command                                                                                                                                                         | Example                                                                                                                                                                                                          |
|-----------------------------------------------------------------|-----------------------------------------------------------------------------------------------------------------------------------------------------------------|------------------------------------------------------------------------------------------------------------------------------------------------------------------------------------------------------------------|
| Cisco uBR7223 router                                            | <b>interface serial</b> , followed by <i>slot/port</i><br>(port-adapter-slot-number/<br>interface-port-number)                                                  | The example is for interface 0 of a port adapter in port adapter slot 1.<br><br>Router(config)# <b>interface serial 1/0</b><br>Router(config-if)#                                                                |
| Cisco uBR7246 router                                            | <b>interface serial</b> , followed by <i>slot/port</i><br>(port-adapter-slot-number/<br>interface-port-number)                                                  | The example is for interface 0 of a port adapter in port adapter slot 2.<br><br>Router(config)# <b>interface serial 2/0</b><br>Router(config-if)#                                                                |
| Cisco 7301 routers                                              | <b>interface serial</b> , followed by <i>slot/port</i><br>(port-adapter-slot-number/<br>interface-port-number)                                                  | The example is for interface 0 of a port adapter in port adapter slot 1.<br><br>Router(config)# <b>interface serial 1/0</b><br>Router(config-if)#                                                                |
| Cisco 7304 PCI Port Adapter Carrier Card in a Cisco 7304 router | <b>interface serial</b> , followed by <i>slot/port</i> (module-slot-number/<br>interface-port-number)                                                           | The example is for interface 0 on a port adapter in a Cisco 7304 PCI Port Adapter Carrier Card in module slot 3 of a Cisco 7304 router.<br><br>Router(config)# <b>interface serial 3/0</b><br>Router(config-if)# |
| Cisco 7401ASR routers                                           | <b>interface serial</b> , followed by <i>slot/port</i><br>(port-adapter-slot-number/<br>interface-port-number)                                                  | The example is for interface 0 of a port adapter in port adapter slot 1.<br><br>Router(config)# <b>interface serial 1/0</b><br>Router(config-if)#                                                                |
| VIP in Cisco 7000 series or Cisco 7500 series routers           | <b>interface serial</b> , followed by <i>slot/port adapter/port</i><br>(interface-processor-slot-number/<br>port-adapter-slot-number/<br>interface-port-number) | The example is for interface 0 of a port adapter in port adapter slot 1 of a VIP in interface processor slot 1.<br><br>Router(config)# <b>interface serial 1/1/0</b><br>Router(config-if)#                       |

- Step 3** Assign an IP address and subnet mask to the interface (if IP routing is enabled on the system) by using the **ip address** sub command, as in the following example:

```
Router(config-if)# ip address 10.0.0.0 10.255.255.255
```

- Step 4** Add any additional configuration subcommands required to enable routing protocols and set the interface characteristics.



**Note** If you are configuring a DTE interface, proceed to Step 6. If you are configuring a DCE interface, you need to configure the external clock signal, which is described in Step 5.

The example in Step 5 applies to all systems in which the PA-8T-X21 is supported.

- Step 5** Set the clock rate using the **clock rate** command. (See the “[Configuring Timing \(Clock\) Signals](#)” section, which follows.)

```
Router(config-if)# clock rate 64000
```

- Step 6** Re enable the interfaces using the **no shutdown** command. (See the “[Shutting Down an Interface](#)” section on page 5-2.)
- Step 7** Configure all additional port adapter interfaces as required.
- Step 8** After including all of the configuration subcommands to complete your configuration, press **Ctrl-Z**—hold down the **Control** key while you press **Z**—or enter **end** or **exit** to exit configuration mode and return to the EXEC command interpreter prompt.
- Step 9** Write the new configuration to NVRAM as follows:

```
Router# copy running-config startup-config
[OK]
Router#
```

This completes the procedure for creating a basic configuration.

## Configuring Timing (Clock) Signals

All PA-8T-X21 interfaces support both DTE and DCE mode, depending on the mode of the interface cable attached to the port. To use a port as a DTE interface, you need only connect a DTE compact serial cable to the port. When the system detects the DTE mode cable, it automatically uses the external timing signal. To use a port in DCE mode, you must connect a DCE interface cable and set the clock speed with the **clock rate** configuration command. You must also set the clock rate to perform a loopback test. This section describes how to set the clock rate on a DCE port and, if necessary, how to invert the clock to correct a phase shift between the data and clock signals. [Table 5-4](#) summarizes some of the commands used to configure the clock rate. See the specific sections that follow for further details.

**Table 5-4** Clock Rate Configuration Commands

| Purpose                                | Command              | Example                                                                                                                                                                                                                        | Additional Information                       |
|----------------------------------------|----------------------|--------------------------------------------------------------------------------------------------------------------------------------------------------------------------------------------------------------------------------|----------------------------------------------|
| Set standard clock rate.               | <b>clock rate</b>    | The example is for a serial interface with a standard clock rate of 72 kbps.<br><br>Router(config)# <b>interface serial 3/0</b><br>Router(config-if)# <b>clock rate 7200</b>                                                   | <a href="#">“Setting the Clock Rate”</a>     |
| Set nonstandard clock rate.            | <b>clock rate</b>    | The example is for a serial interface with a nonstandard clock rate of 1234567 kbps.<br><br>Router(config)# <b>interface serial 3/0</b><br>Router(config-if)# <b>clock rate 1234567</b>                                        | <a href="#">“Setting the Clock Rate”</a>     |
| Remove a clock rate that has been set. | <b>no clock rate</b> | The example is for a serial interface and removes a standard clock rate of 72 kbps.<br><br>Router(config)# <b>interface serial 3/0</b><br>Router(config-if)# <b>clock rate 7200</b><br>Router(config-if)# <b>no clock rate</b> | <a href="#">“Setting the Clock Rate”</a>     |
| Invert the transmit clock signal.      | <b>invert-txc</b>    | The example inverts the transmit clock signal for a serial interface.<br><br>Router(config)# <b>interface serial 3/0</b><br>Router(config-if)# <b>invert-txc</b>                                                               | <a href="#">“Inverting the Clock Signal”</a> |

Table 5-4 Clock Rate Configuration Commands (continued)

| Purpose                                             | Command              | Example                                                                                                                                                                                     | Additional Information                       |
|-----------------------------------------------------|----------------------|---------------------------------------------------------------------------------------------------------------------------------------------------------------------------------------------|----------------------------------------------|
| Change the clock signal back to its original phase. | <b>no invert-txc</b> | The example sets the transmit clock signal for a serial interface back to its original phase.<br><br>Router(config)# <b>interface serial 3/0</b><br>Router(config-if)# <b>no invert-txc</b> | <a href="#">“Inverting the Clock Signal”</a> |
| Invert the data signal.                             | <b>invert data</b>   | The example inverts the data stream for both transmit and receive for a serial interface:<br><br>Router(config)# <b>interface serial 3/0</b><br>Router(config-if)# <b>invert-data</b>       | <a href="#">“Inverting the Clock Signal”</a> |

## Setting the Clock Rate

The default operation on a PA-8T-X21 DCE interface is for the DCE device to generate its own clock signal (TxC) and send it to the remote DTE. The remote DTE device returns the clock signal to the DCE (PA-8T-X21). Set the clock rate of an interface using the **clock rate** sub command, which specifies the clock rate as a bits-per-second value.

Before you can assign a clock rate, you must use the **interface serial** command (followed by the interface address of the interface) to select the interface to which you want to assign the clock rate value.

In the following example, the clock rate is specified as 72 kbps:

```
Router(config-if)# clock rate 72000
```

The preceding command example applies to all systems in which the PA-8T-X21 is supported. Use the **no clock rate** command to remove the clock rate.

Following are the standard clock rates:

```
1200, 2400, 4800, 9600, 19200 38400, 56000, 64000,
72000, 125000 148000, 250000, 500000, 800000, 1000000,
1300000, 2000000, 4000000, 8000000
```

When you are done, press **Ctrl-Z**—hold down the **Control** key while you press **Z**—or enter **end** or **exit** to exit configuration mode and return to the EXEC command interpreter prompt. Then write the new configuration to NVRAM using the **copy running-config startup-config** command.



### Note

Cisco IOS Release 11.2(7a)P or later or 11.1(10)CA or later loaded on your Cisco 7200, Cisco 7000 series, or Cisco 7500 series router with a VIP2-40(=) supports nonstandard clock rates (any value from 1200 to 8000000) on PA-8T-V35 interfaces.

Cisco IOS Release 11.3(6)NA or later or Cisco IOS Release 12.0(3)T or later loaded on your Cisco uBR7200 series supports nonstandard clock rates (any value from 1200 to 8000000) on PA-8T-V35 interfaces.

Nonstandard clock rates are rounded (if necessary) to the nearest clock rate that the hardware can support.

Set a nonstandard clock rate for an interface using the **clock rate** sub command. Before you can assign a nonstandard clock rate, you must use the **interface serial** command (followed by the interface address of the interface) to select the interface to which you want to assign the nonstandard clock rate value.

In the following example, a nonstandard clock rate of 1234567 bps is specified:

```
Router(config-if)# clock rate 1234567
```

The preceding command example applies to all systems in which the PA-8T-X21 is supported. Use the **no clock rate** command to remove the clock rate.

When you are done, press **Ctrl-Z**—hold down the **Control** key while you press **Z**—or enter **end** or **exit** to exit configuration mode and return to the EXEC command interpreter prompt. Then write the new configuration to NVRAM using the **copy running-config startup-config** command.

The following example shows how to use the **show running-config** command to determine the exact clock rate to which the nonstandard clock rate was rounded:

```
Router# show running-config
Building configuration...
...
!
interface Serial1/0 (interface Serial3/1/0 on a VIP2 or FlexWAN module)

 no ip address
 clockrate 1151526
!
...
```

In the preceding example, only the relevant output from the **show running-config** command is shown; other information is omitted.

## Inverting the Clock Signal

Systems that use long cables or cables that are not transmitting the TxC (clock) signal might experience high error rates when operating at the higher transmission speeds. If a PA-8T-X21 DCE port is reporting a high number of error packets, a phase shift might be the problem. Inverting the clock might correct this phase shift.

When the PA-8T-X21 interface is a DTE, the **invert-txc** command inverts the TxC signal it receives from the remote DCE. When the PA-8T-X21 interface is a DCE, this command inverts the clock signal to the remote DTE port. Use the **no invert-txc** command to change the clock signal back to its original phase.

## Inverting the Data Signal

If the interface on the PA-8T-X21 is used to drive a dedicated T1 line that does not have B8ZS encoding (a method to avoid 15 zeros), the data stream must be inverted (both TxD and RxD) either in the connecting CSU or DSU or the interface. To invert the data stream coming out of the PA-8T-X21, use the **invert data** command. By inverting the HDLC data stream, the HDLC zero insertion algorithm becomes a ones insertion algorithm that satisfies the T1 requirements.



### Note

Invert data *only* on the PA-8T-X21 interface *or* on the CSU/DSU; inverting both cancel out both data inversions.

## Configuring NRZI Format

Table 5-5 summarizes NRZI format commands. For more information, see the remainder of this section.

Table 5-5 NRZI Format Commands

| Purpose                | Command                                           | Example                                                                                                                                                                                                                                                                                                                                 | Further Information                       |
|------------------------|---------------------------------------------------|-----------------------------------------------------------------------------------------------------------------------------------------------------------------------------------------------------------------------------------------------------------------------------------------------------------------------------------------|-------------------------------------------|
| Enable NRZI encoding.  | <b>nrzi-encoding</b> [ <i>mark</i> ] <sup>1</sup> | The example is for a serial interface with NRZI mark encoding specified:<br><br><pre>Router(config)# interface serial 3/0 Router(config-if)# nrzi-encoding mark</pre> The example is for a serial interface with NRZI space encoding specified:<br><br><pre>Router(config)# interface serial 3/0 Router(config-if)# nrzi-encoding</pre> | <a href="#">“Configuring NRZI Format”</a> |
| Disable NRZI encoding. | <b>no nrzi-encoding</b>                           | The example disables NRZI encoding on a serial interface:<br><br><pre>Router(config)# interface serial 3/0 Router(config-if)# no nrzi-encoding</pre>                                                                                                                                                                                    | <a href="#">“Configuring NRZI Format”</a> |

- Mark* is an optional argument. When *mark* is used, it means there is no signal transition; there is data (a mark) at the beginning of a bit interval. When *mark* is not used, it means there is a signal transition; there is no data (a space) at the beginning of a bit interval.

All PA-8T-X21 interfaces support non return-to-zero (NRZ) and non return-to-zero inverted (NRZI) formats. Both formats use two different voltage levels for transmission. NRZ signals maintain constant voltage levels with no signal transitions (no return to a zero voltage level) during a bit interval and are decoded using absolute values (0 and 1). NRZI uses the same constant signal levels but interprets the absence of data (a space) at the beginning of a bit interval as a signal transition and the presence of data (a mark) as no transition. NRZI uses relational encoding to decode signals rather than determining absolute values.

NRZ format—the factory default on all interfaces—is more common. NRZI format is commonly used with EIA/TIA-X.21 connections in IBM environments.

Enable NRZI encoding on any interface using the **nrzi-encoding** [*mark*] command, where no argument after the command is interpreted as a signal transition, and *mark* is interpreted as no signal transition. Before you can enable NRZI encoding, you must use the **interface serial** command (followed by the interface address of the interface) to select the interface on which you want to enable NRZI encoding.

In the example that follows, NRZI encoding with a signal transition—no argument—is specified:

```
Router(config-if)# nrzi-encoding
```

In the example that follows, NRZI encoding with no signal transition—with argument—is specified:

```
Router(config-if)# nrzi-encoding mark
```

The preceding command examples apply to all systems in which the PA-8T-X21 is supported. Use the **no nrzi-encoding** command to disable NRZI encoding.

When you are done, press **Ctrl-Z**—hold down the **Control** key while you press **Z**—or enter **end** or **exit** to exit configuration mode and return to the EXEC command interpreter prompt. Then write the new configuration to NVRAM using the **copy running-config startup-config** command.

For complete command descriptions and instructions, refer to the *Configuration Fundamentals Configuration Guide* publication. For more information, see the “[Obtaining Documentation](#)” section on page x and the “[Obtaining Technical Assistance](#)” section on page xi.

## Configuring Cyclic Redundancy Checks

[Table 5-6](#) summarizes cyclic redundancy check (CRC) commands. For more information, see the remainder of this section.

**Table 5-6** CRC Commands

| Purpose                       | Command                  | Example                                                                                                                                                                                | Further Information                                    |
|-------------------------------|--------------------------|----------------------------------------------------------------------------------------------------------------------------------------------------------------------------------------|--------------------------------------------------------|
| Enable 32-bit CRC.            | <code>crc size</code>    | The example enables 32-bit CRC on a serial interface:<br><br>Router(config)# <b>interface serial 3/0</b><br>Router(config-if)# <b>crc 32</b>                                           | <a href="#">“Configuring Cyclic Redundancy Checks”</a> |
| Return to default 16-bit CRC. | <code>no crc size</code> | The example disables 32-bit CRC on a serial interface and returns to the default 16-bit CRC:<br><br>Router(config)# <b>interface serial 3/0</b><br>Router(config-if)# <b>no crc 32</b> | <a href="#">“Configuring Cyclic Redundancy Checks”</a> |

CRC is an error-checking technique that uses a calculated numeric value to detect errors in transmitted data. All interfaces use a 16-bit CRC (CRC-CITT) by default but also support a 32-bit CRC. The sender of a data frame calculates the *frame check sequence* (FCS). Before it sends a frame, the sender appends the FCS value to the message. The receiver recalculates the FCS and compares its calculation to the FCS from the sender. If there is a difference between the two calculations, the receiver assumes that a transmission error occurred and sends a request to the sender to re send the frame.

Enable 32-bit CRC using the `crc 32` command. Before you can enable 32-bit CRC, you must use the `interface serial` command (followed by the interface address of the interface) to select the interface on which you want to enable 32-bit CRC. This command functions in the same way on all supported platforms.

In the example that follows, 32-bit CRC is specified:

```
Router(config-if)# crc 32
```

The preceding command example applies to all systems in which the PA-8T-X21 is supported. Use the `no crc 32` command to disable CRC-32 and return the interface to the default CRC-16 (CRC-CITT) setting.

When you are done, press **Ctrl-Z**—hold down the **Control** key while you press **Z**—or enter `end` or `exit` to exit configuration mode and return to the EXEC command interpreter prompt. Then write the new configuration to NVRAM using the `copy running-config startup-config` command.

For command descriptions, refer to the *Configuration Fundamentals Configuration Guide* publication. For more information, see the “[Obtaining Documentation](#)” section on page x and the “[Obtaining Technical Assistance](#)” section on page xi.

**Note**

If you are configuring a PA-8T-X21 on a Cisco 7200 series router and you want to configure the interface for half-duplex or Bisync operation, proceed to the next section “[Configuring Half-Duplex and Binary Synchronous Communications](#)”; otherwise, proceed to the “[Checking the Configuration](#)” section on [page 5-17](#).

## Configuring Half-Duplex and Binary Synchronous Communications

This section explains how to configure PA-8T-X21 interfaces for half-duplex and Bisync operation in Cisco 7100 series or Cisco 7200 routers.

**Note**

Cisco IOS Release 11.2(7a)P or later supports half-duplex and Bisync operation on PA-8T-X21 port adapters in Cisco 7200 routers.

The Catalyst 6000 family FlexWAN module, Cisco uBR7200 series routers, Cisco 7401ASR routers, and the VIP do not support half-duplex and Bisync operation on PA-8T-X21 port adapters.

Use the **half-duplex** command to configure PA-8T-X21 interfaces for half-duplex mode; full-duplex mode is the default for low-speed serial interfaces. Serial DCE interfaces in half-duplex mode can be configured for controlled-carrier mode or constant-carrier mode; constant-carrier mode is the default. Controlled-carrier mode sets the PA-8T-X21 interface to deactivate data carrier detect (DCD) until a transmission is sent to the interface. After a transmission is received, DCD is activated and the interface waits a user-configured amount of time, and then transmits the data. After the transmission, the interface waits a user-configured amount of time and then deactivates DCD. Constant-carrier mode activates DCD at all times.

Use the **half-duplex controlled-carrier** command to configure a PA-8T-X21 interface for controlled-carrier mode. Use the **no half-duplex controlled-carrier** command to return the interface to constant-carrier mode.

Follow these steps to configure controlled-carrier mode on a PA-8T-X21 interface:

- Step 1** Enter configuration mode and specify that the console terminal is the source of the configuration subcommands, as follows:

```
Router# configure terminal
Enter configuration commands, one per line. End with CNTL/Z.
Router(config)#
```

- Step 2** Specify the interface to configure for controlled-carrier mode using the **interface serial** subcommand (followed by the interface address of the interface) and then enter the **half-duplex controlled-carrier** subcommand.

The following example is for the first interface of the port adapter in port adapter slot 1:

```
Router(config)# interface serial 1/0
Router(config-if)# half-duplex controlled-carrier
```

- Step 3** Specify the length of the timer delay the interface uses when it is configured for controlled-carrier mode by using the following command:

**half-duplex timer** { *cts-delay value* | *cts-drop-timeout value* | *dcd-drop-delay value* | *dcd-txstart-delay value* | *rts-drop-delay value* | *rts-timeout value* | *transmit-delay value* }

where *value* is the length of the timer delay in milliseconds.

The following example specifies a Data Carrier Detect (DCD) drop delay of 100 milliseconds on the first interface of a port adapter in port adapter slot 1:

```
Router(config)# interface serial 1/0
Router(config-if)# half-duplex timer dcd-drop-delay 100 ms
```

[Table 5-7](#) lists the default delay settings and the *value* argument for each timer you can use with the **half-duplex timer** command.

**Table 5-7** Half-Duplex Timer Default Delay Settings

| Timer                        | Command Syntax                             | Default Settings <sup>1</sup> |
|------------------------------|--------------------------------------------|-------------------------------|
| CTS delay <sup>2</sup>       | <b>half-duplex timer cts-delay</b>         | 0                             |
| CTS drop timeout             | <b>half-duplex timer cts-drop-timeout</b>  | 250                           |
| DCD drop delay <sup>3</sup>  | <b>half-duplex timer dcd-drop-delay</b>    | 100                           |
| DCD transmission start delay | <b>half-duplex timer dcd-txstart-delay</b> | 100                           |
| RTS drop delay <sup>4</sup>  | <b>half-duplex timer rts-drop-delay</b>    | 3                             |
| RTS timeout                  | <b>half-duplex timer rts-timeout</b>       | 3                             |
| Transmit delay               | <b>half-duplex transmit-delay</b>          | 0                             |

1. In milliseconds (ms).
2. Clear to Send (CTS).
3. Data Carrier Detect (DCD).
4. Request to Send (RTS).

**Step 4** Complete the configuration by pressing **Ctrl-Z**—hold down the **Control** key while you press **Z**—or entering **end** or **exit** to exit configuration mode and return to the EXEC command interpreter prompt.

**Step 5** Write the new configuration to NVRAM as follows:

```
Router# copy running-config startup-config
[OK]
Router#
```

This completes the procedure for configuring controlled-carrier mode on an EIA/TIA-X21 interface. For additional information on configuring half-duplex operation on low-speed serial interfaces, refer to the chapter “Configuring Interfaces” of the *Configuration Fundamentals Configuration Guide* publication. For more information, see the “[Obtaining Documentation](#)” section on page x and the “[Obtaining Technical Assistance](#)” section on page xi.



**Note**

To configure EIA/TIA-X21 interfaces for Binary Synchronous (Bisync) operation in Cisco 7200 series routers, refer to the “Block Serial Tunneling (BSTUN)” section of the “Configuring Serial Tunnel (STUN) and Block Serial Tunnel (BSTUN)” chapter of the *Bridging and IBM Networking Configuration Guide*.

## Checking the Configuration

After configuring the new interface, use the **show** commands to display the status of the new interface or all interfaces, and use the **ping** and **loopback** commands to check connectivity. This section includes the following subsections:

- [Using show Commands to Verify the New Interface Status, page 5-17](#)
- [Using the ping Command to Verify Network Connectivity, page 5-28](#)
- [Using loopback Commands, page 5-28](#)

## Using show Commands to Verify the New Interface Status

[Table 5-8](#) demonstrates how you can use the **show** commands to verify that new interfaces are configured and operating correctly and that the PA-8T-X21 appears in them correctly. Sample displays of the output of selected **show** commands appear in the sections that follow. For complete command descriptions and examples, refer to the publications listed in the “[Related Documentation](#)” section on [page viii](#).

**Note**

The outputs that appear in this document may not match the output you receive when running these commands. The outputs in this document are examples only.

**Table 5-8** Using show Commands

| Command                                                                                                           | Function                                                                                                                                                                   | Example                         |
|-------------------------------------------------------------------------------------------------------------------|----------------------------------------------------------------------------------------------------------------------------------------------------------------------------|---------------------------------|
| <b>show version</b> or<br><b>show hardware</b>                                                                    | Displays system hardware configuration, the number of each interface type installed, Cisco IOS software version, names and sources of configuration files, and boot images | Router# <b>show version</b>     |
| <b>show controllers</b>                                                                                           | Displays all the current interface processors and their interfaces                                                                                                         | Router# <b>show controllers</b> |
| <b>show diag slot</b><br><b>Note</b> The <i>slot</i> argument is not required with Catalyst 5000 family switches. | Displays types of port adapters installed in your system and information about a specific port adapter slot, interface processor slot, or chassis slot                     | Router# <b>show diag 2</b>      |

Table 5-8 Using show Commands (continued)

| Command                                                                                                                   | Function                                                                                                                      | Example                                     |
|---------------------------------------------------------------------------------------------------------------------------|-------------------------------------------------------------------------------------------------------------------------------|---------------------------------------------|
| <b>show interfaces</b> <i>type 0</i> or <i>1/</i><br><i>interface-port-number</i>                                         | Displays status information about a specific type of interface (for example, serial) on a Catalyst RSM/VIP2                   | Router# <b>show interfaces serial 1/0</b>   |
| <b>show interfaces</b> <i>type module-slot-number/</i><br><i>port-adapter-bay-number/interface-port-</i><br><i>number</i> | Displays status information about a specific type of interface (for example, serial) on a Catalyst 6000 family FlexWAN module | Router# <b>show interfaces serial 3/0/0</b> |
| <b>show interfaces</b> <i>type 3/</i> <i>interface-port-</i><br><i>number</i>                                             | Displays status information about a specific type of interface (for example, serial) in a Cisco 7120 series router            | Router# <b>show interfaces serial 3/1</b>   |
| <b>show interfaces</b> <i>type 4/</i> <i>interface-port-</i><br><i>number</i>                                             | Displays status information about a specific type of interface (for example, serial) in a Cisco 7140 series router            | Router# <b>show interfaces serial 4/1</b>   |
| <b>show interfaces</b> <i>type</i><br><i>port-adapter-slot-number/</i><br><i>interface-port-number</i>                    | Displays status information about a specific type of interface (for example, serial) in a Cisco 7200 series router            | Router# <b>show interfaces serial 1/0</b>   |
| <b>show interfaces</b> <i>type 1/</i> <i>interface-port-</i><br><i>number</i>                                             | Displays status information about a specific type of interface (for example, serial) in a Cisco uBR7223 router                | Router# <b>show interfaces serial 1/1</b>   |
| <b>show interfaces</b> <i>type 1</i> or <i>2/</i><br><i>interface-port-number</i>                                         | Displays status information about a specific type of interface (for example, serial) in a Cisco uBR7246 router                | Router# <b>show interfaces serial 2/0</b>   |
| <b>show interfaces</b> <i>type 1/</i><br><i>interface-port-number</i>                                                     | Displays status information about a specific type of interface (for example, ethernet) in a Cisco 7301 router                 | Router# <b>show interfaces serial 1/0</b>   |
| <b>show interfaces</b> <i>type 2</i> or <i>3</i> or <i>4</i> or <i>5/</i><br><i>interface-port-number</i>                 | Displays status information about a serial interface on a Cisco 7304 PCI Port Adapter Carrier Card in a Cisco 7304 router     | Router# <b>show interfaces serial 3/0</b>   |
| <b>show interfaces</b> <i>type 1/</i><br><i>interface-port-number</i>                                                     | Displays status information about a specific type of interface (for example, ethernet) in a Cisco 7401ASR router              | Router# <b>show interfaces serial 1/0</b>   |

Table 5-8 Using show Commands (continued)

| Command                                                                                                           | Function                                                                                                                                         | Example                                     |
|-------------------------------------------------------------------------------------------------------------------|--------------------------------------------------------------------------------------------------------------------------------------------------|---------------------------------------------|
| <b>show interfaces</b> <i>type interface-processor-slot-number/port-adapter-slot-number/interface-port-number</i> | Displays status information about a specific type of interface (for example, serial) on a VIP in a Cisco 7000 series or Cisco 7500 series router | Router# <b>show interfaces serial 3/1/0</b> |
| <b>show protocols</b>                                                                                             | Displays protocols configured for the entire system and for specific interfaces                                                                  | Router# <b>show protocols</b>               |
| <b>show running-config</b>                                                                                        | Displays the running configuration file                                                                                                          | Router# <b>show running-config</b>          |
| <b>show startup-config</b>                                                                                        | Displays the configuration stored in NVRAM                                                                                                       | Router# <b>show startup-config</b>          |

If an interface is shut down and you configured it as up, or if the displays indicate that the hardware is not functioning properly, ensure that the interface is properly connected and terminated. If you still have problems bringing up the interface, contact a service representative for assistance. This section includes the following subsections:

- [Using the show version Commands, page 5-19](#)
- [Using the show diag Command, page 5-23](#)
- [Using the show interfaces Command, page 5-26](#)

Choose the subsection appropriate for your system. Proceed to the “[Using the ping Command to Verify Network Connectivity](#)” section on [page 5-28](#) when you have finished using the **show** commands.

## Using the show version Commands

Display the configuration of the system hardware, the number of each interface type installed, the Cisco IOS software version, the names and sources of configuration files, and the boot images, using the **show version** (or **show hardware**) command. This section provides output examples for some of the supported platforms.



### Note

The outputs that appear in this document may not match the output you receive when running these commands. The outputs in this document are examples only.

## Catalyst RSM/VIP2 in Catalyst 5000 Family Switches

Following is an example of the **show version** command from a Catalyst 5000 series switch:

```
Router# show version

Cisco Internetwork Operating System Software
IOS (tm) GS Software (RSP-A), Version 11.1(471) [biff 125]
Copyright (c) 1986-1996 by cisco Systems, Inc.
Compiled Sat 10-Aug-96 17:56 by biff
Image text-base: 0x600108A0, data-base: 0x60952000

ROM: System Bootstrap, Version 5.3(16645) [biff 571]
ROM: GS Software (RSP-BOOT-M), Version 11.1(6), RELEASE SOFTWARE (fc1)
```

```

gshen_7500 uptime is 5 days, 4 minutes
System restarted by reload
System image file is "rsp-jv-mz", booted via slot0

cisco RSP2 (R4600) processor with 16384K bytes of memory.
R4600 processor, Implementation 32, Revision 2.0
Last reset from power-on
G.703/E1 software, Version 1.0.
SuperLAT software copyright 1990 by Meridian Technology Corp).
Bridging software.
X.25 software, Version 2.0, NET2, BFE and GOSIP compliant.
TN3270 Emulation software (copyright 1994 by TGV Inc).
Chassis Interface.
1 EIP controller (6 Ethernet).
1 VIP2 controller (8 Ethernet)(1 HSSI).
14 Ethernet/IEEE 802.3 interfaces.
1 HSSI network interface.
125K bytes of non-volatile configuration memory.

8192K bytes of Flash PCMCIA card at slot 0 (Sector size 128K).
8192K bytes of Flash internal SIMM (Sector size 256K).
Configuration register is 0x0

```

## Catalyst 6000 Family FlexWAN Module in Catalyst 6000 Family Switches

Following is an example of the **show version** command from a Catalyst 6000 series switch:

```

Router# show version
Cisco Internetwork Operating System Software
IOS (tm) MSFC Software (C6MSFC-JSV-M), Version 12.1(1)EX [amcrae-cosmos_e_nightly 163]
Copyright (c) 1986-2000 by cisco Systems, Inc.
Compiled Wed 09-Feb-00 07:10 by
Image text-base: 0x60008900, data-base: 0x6140E000

ROM: System Bootstrap, Version 12.0(3)XE, RELEASE SOFTWARE

const-uut uptime is 5 minutes
System returned to ROM by reload
System image file is "bootflash:c6msfc-jsv-mz.Feb9"

cisco Cat6k-MSFC (R5000) processor with 122880K/8192K bytes of memory.
Processor board ID SAD03457061
R5000 CPU at 200Mhz, Implementation 35, Rev 2.1, 512KB L2 Cache
Last reset from power-on
Channelized E1, Version 1.0.
Bridging software.
X.25 software, Version 3.0.0.
SuperLAT software (copyright 1990 by Meridian Technology Corp).
TN3270 Emulation software.
Primary Rate ISDN software, Version 1.1.
6 FlexWAN controllers (13 Serial)(8 E1)(8 T1)(2 HSSI)(2 ATM)(1 Channelized T3)(1
Channelized E3)(2 POS).
1 Virtual Ethernet/IEEE 802.3 interface(s)
17 Serial network interface(s)
2 HSSI network interface(s)
2 ATM network interface(s)
2 Packet over SONET network interface(s)
1 Channelized T3 port(s)
1 Channelized E3 port(s)
123K bytes of non-volatile configuration memory.
4096K bytes of packet SRAM memory.

```

```
16384K bytes of Flash internal SIMM (Sector size 256K).
Configuration register is 0x1
```

## Cisco 7200 Series, Cisco uBR7200 Series Routers, and Cisco 7401ASR Routers

Following is an example of the **show version** command from a Cisco 7200 series router:

```
Router# show version

Cisco Internetwork Operating System Software
IOS (tm) 7200 Software (C7200-J-M), Version 11.1(7)CA [biff 105]
Copyright (c) 1986-1996 by cisco Systems, Inc.
Compiled Sun 04-Aug-96 06:00 by biff
Image text-base: 0x600088A0, data-base: 0x605A4000

ROM: System Bootstrap, Version 11.1(7)CA RELEASED SOFTWARE

Router uptime is 4 hours, 22 minutes
System restarted by reload
System image file is "c7200-j-mz", booted via slot0

cisco 7206 (NPE150) processor with 12288K/4096K bytes of memory.
R4700 processor, Implementation 33, Revision 1.0 (Level 2 Cache)
Last reset from power-on
Bridging software.
SuperLAT software copyright 1990 by Meridian Technology Corp.
X.25 software, Version 2.0, NET2, BFE and GOSIP compliant.
TN3270 Emulation software (copyright 1994 by TGV INC).
Chassis Interface.
4 Ethernet/IEEE 802.3 interfaces.
2 FastEthernet/IEEE 802.3 interfaces.
4 Token Ring /IEEE802.5 interfaces.
12 Serial network interfaces.
1 Compression port adapter.
125K bytes of non-volatile configuration memory.
1024K bytes of packet SRAM memory.

20480K bytes of Flash PCMCIA card at slot 0 (Sector size 128K).
8192K bytes of Flash internal SIMM (Sector size 256K).
Configuration register is 0x2
```

## Cisco 7301 Routers

```
Router# show version

Cisco Internetwork Operating System Software
IOS (tm) 7301 Software (C7300-JS-M), Experimental Version 12.2(20020904:004736) [biff 107]
Copyright (c) 1986-2002 by cisco Systems, Inc.
Compiled Mon 09-Sep-02 18:02 by biff
Image text-base:0x600088F8, data-base:0x61A94000

ROM: System Bootstrap, Version 12.2(20020730:200705) [biff-TAZ2_QA_RELEASE_16B 101],
DEVELOPMENT SOFTWARE
BOOTLDR:7301 Software (C7301-BOOT-M), Experimental Version 12.2(20020813:014224)
[biff-TAZ2_QA_RELEASE_17B 101]

7301p2b uptime is 0 minutes
System returned to ROM by reload at 00:01:51 UTC Sat Jan 1 2000
System image file is "tftp://10.1.8.11/tazii/images/c7301-js-mz"

cisco 7301 (NPE-G1) processor (revision A) with 491520K/32768K bytes of memory.
```

```

Processor board ID 0
BCM1250 CPU at 700Mhz, Implementation 1, Rev 0.2, 512KB L2 Cache
1 slot midplane, Version 2.0

Last reset from power-on
Bridging software.
X.25 software, Version 3.0.0.
SuperLAT software (copyright 1990 by Meridian Technology Corp).
TN3270 Emulation software.
3 Gigabit Ethernet/IEEE 802.3 interface(s)
509K bytes of non-volatile configuration memory.

62976K bytes of ATA PCMCIA card at slot 0 (Sector size 512 bytes).
32768K bytes of Flash internal SIMM (Sector size 256K).
Configuration register is 0x102

```

## Cisco 7401ASR Routers

Following is an example of the **show version** command from a Cisco 7401ASR router:

```

Router# show version

Cisco Internetwork Operating System Software
IOS (tm) 7401ASR Software (C7401ASR-J-M), Version 11.1(6)CA
Copyright (c) 1986-1996 by cisco Systems, Inc.
Compiled Sun 21-Apr-95 12:22 by
Image text-base: 0x600088A0, data-base: 0x605A4000

ROM: System Bootstrap, Version 11.1(6)CA

Router uptime is 4 hours, 22 minutes
System restarted by reload
System image file is "slot0:c7401ASR-j-mz.960421", booted via slot0

cisco 7401ASR (R4700) processor with 22528K/10240K bytes of memory.
R4700 processor, Implementation 33, Revision 1.0 (Level 2 Cache)
Last reset from power-on
Bridging software.
X.25 software, Version 2.0, NET2, BFE and GOSIP compliant.
Chassis Interface.
4 Ethernet/IEEE 802.3 interfaces.
2 FastEthernet/IEEE 802.3 interfaces.
125K bytes of non-volatile configuration memory.

20480K bytes of Flash PCMCIA card at slot 0 (Sector size 128K).
8192K bytes of Flash internal SIMM (Sector size 256K).
Configuration register is 0x2

```

## VIP in Cisco 7000 Series and Cisco 7500 Series Routers

Following is an example of the **show version** command from a Cisco 7500 series router:

```

Router# show version

Cisco Internetwork Operating System Software
IOS (tm) GS Software (RSP-A), Version 11.1(471) [biff 125]
Copyright (c) 1986-1996 by cisco Systems, Inc.
Compiled Sat 10-Aug-96 17:56 by biff
Image text-base: 0x600108A0, data-base: 0x60952000

ROM: System Bootstrap, Version 5.3(16645) [biff 571]

```

```

ROM: GS Software (RSP-BOOT-M), Version 11.1(6), RELEASE SOFTWARE (fc1)

gshen_7500 uptime is 5 days, 4 minutes
System restarted by reload
System image file is "rsp-jv-mz", booted via slot0

cisco RSP2 (R4600) processor with 16384K bytes of memory.
R4600 processor, Implementation 32, Revision 2.0
Last reset from power-on
G.703/E1 software, Version 1.0.
SuperLAT software copyright 1990 by Meridian Technology Corp).
Bridging software.
X.25 software, Version 2.0, NET2, BFE and GOSIP compliant.
TN3270 Emulation software (copyright 1994 by TGV Inc).
Chassis Interface.
1 EIP controller (6 Ethernet).
1 VIP2 controller (8 Ethernet)(1 HSSI).
14 Ethernet/IEEE 802.3 interfaces.
1 HSSI network interface.
125K bytes of non-volatile configuration memory.

8192K bytes of Flash PCMCIA card at slot 0 (Sector size 128K).
8192K bytes of Flash internal SIMM (Sector size 256K).
Configuration register is 0x0

```

## Using the show diag Command

Display the types of port adapters installed in your system (and specific information about each) using the **show diag slot** command, where *slot* is the *port adapter slot* in a Cisco 7100 series, Cisco 7200 series, Cisco uBR7200 series router, Cisco 7301 routers, and Cisco 7401ASR routers and the *interface processor slot* in a Cisco 7000 series or Cisco 7500 series router with a VIP. This section provides output examples for some of the supported platforms.



Note

The outputs that appear in this document may not match the output you receive when running these commands. The outputs in this document are examples only.



Note

The *slot* argument is not required for the Catalyst 5000 family switches.

### Catalyst RSM/VIP2 in Catalyst 5000 Family Switches

Following is an example of the **show diag** command that shows a PA-8T-X21 in a Catalyst RSM/VIP2:

```

Router# show diag
Slot 1:
Mueslix serial (X.21) port adapter, 8 ports
Port adapter is analyzed
Port adapter insertion time 2d09h ago
Hardware revision 1.13 Board revision UNKNOWN
Serial number 4294967295 Part number 255-65535-255
Test history 0xFF RMA number 255-255-255
EEPROM format version 1
EEPROM contents (hex):
0x20:01 0E 01 0D FF FF FF FF FF FF FF FF FF FF FF FF
0x30:FF FF FF FF FF FF FF FF FF FF FF FF FF FF FF FF

Slot database information:

```

```
Flags: 0x4 Insertion time: 0x12A0 (08:56:58 ago)
```

**Note**

---

The slot values 0 and 7 are not relevant to any physical connection; disregard these slot values.

---

### Catalyst 6000 Family FlexWAN Module in Catalyst 6000 Family Switches

Following is an example of the **show diag** command that shows a PA-8T-X21 in a Catalyst 6000 family FlexWAN module:

```
Router# show diag

(display text omitted)

Slot 8: Logical_index 17
 Board is analyzed ipc ready FlexWAN controller

Slot database information:
Flags: 0x2004Insertion time: unknown

CWAN Controller Memory Size: Unknown

PA Bay 1 Information:
 Mx Serial PA, 8 ports
 EEPROM format version 0
 HW rev 0.00, Board revision UNKNOWN
 Serial number: 00000000 Part number: 00-0000-00
```

### Cisco 7200 Series, Cisco uBR7200 Series Routers, and Cisco 7401ASR Routers

Following is an example of the **show diag slot** command that shows a PA-8T-X21 in port adapter slot 1:

```
Router# show diag 1

Slot 1:
Mueslix serial (X.21) port adapter, 8 ports
Port adapter is analyzed
Port adapter insertion time 2d09h ago
Hardware revision 255.255 Board revision UNKNOWN
Serial number 4294967295 Part number 255-65535-255
Test history 0xFF RMA number 255-255-255
EEPROM format version 1
EEPROM contents (hex):
0x20: 01 0D FF FF FF FF FF FF FF FF FF FF FF FF FF
0x30: FF FF FF FF FF FF FF FF FF FF FF FF FF FF FF
```

**Note**

---

Port adapters used with the Cisco 7200 VXR routers require the correct base hardware revision in order to function. The following error message occurs on bootup if the incorrect hardware revision is used:

```
PA-3-REVNOTSUPPORTED:PA in slot 1 (Ethernet) requires base h/w revision of (1.14) for this chassis
```

Use the **show diag** command to display the hardware revision.

---



## Cisco 7301 Routers



## Note

Input/output data for the console port, auxiliary port, Gigabit Ethernet ports, and CompactFlash Disk are listed in the output of the **show c7300** command, rather than in the output of the **show diag** command. Use the **show diag** command for port adapter information.

```
Router# sh diag

Slot 1:
 POS Single Width, Multi Mode Port adapter, 1 port
 Port adapter is analyzed
 Port adapter insertion time 01:38:29 ago
 EEPROM contents at hardware discovery:
 Hardware revision 2.2 Board revision A0
 Serial number 28672741 Part number 73-3192-06
 FRU Part Number:PA-POS-OC3MM=

 Test history 0x0 RMA number 00-00-00
 EEPROM format version 1
 EEPROM contents (hex):
 0x20:01 96 02 02 01 B5 82 E5 49 0C 78 06 00 00 00 00
 0x30:50 00 00 00 02 08 19 00 00 00 FF FF FF FF FF FF
```

## VIP in Cisco 7000 Series and Cisco 7500 Series Routers

Following is an example of the **show diag slot** command that shows a PA-8T-X21 in port adapter slot 0 on a VIP in interface processor slot 1:

```
Router# show diag 1

Slot 1:
 Mueslix serial (X.21) port adapter, 8 ports
 Port adapter is analyzed
 Port adapter insertion time 2d09h ago
 Hardware revision 1.13 Board revision UNKNOWN
 Serial number 4294967295 Part number 255-65535-255
 Test history 0xFF RMA number 255-255-255
 EEPROM format version 1
 EEPROM contents (hex):
 0x20:01 0E 01 0D FF FF FF FF FF FF FF FF FF FF FF FF
 0x30:FF FF FF FF FF FF FF FF FF FF FF FF FF FF FF FF

 Slot database information:
 Flags: 0x4 Insertion time: 0x12A0 (08:56:58 ago)

 Controller Memory Size: 8 MBytes

 PA Bay 0 Information:
 Mueslix Serial PA, 8 ports
 EEPROM format version 1
 HW rev FF.FF, Board revision UNKNOWN
 Serial number: 4294967295 Part number: 255-65535-255

 PA Bay 1 Information:
 Fast-Serial PA, 4 ports
 EEPROM format version 1
 HW rev 1.0, Board revision A0
 Serial number: 02024473 Part number: 73-1389-05
```

## Using the show interfaces Command

The **show interfaces** command displays status information (including the physical slot and interface address) for the interfaces you specify. This section provides output examples for some of the supported platforms; all of the examples specify serial interfaces.

For complete descriptions of interface subcommands and the configuration options available for Catalyst RSM/VIP2, Cisco 7100 series, Cisco 7200 series, Cisco uBR7200 series, Cisco 7301 routers, Cisco 7401ASR routers, and VIP interfaces, refer to the publications listed in the [“Related Documentation” section on page viii](#).



### Note

The outputs that appear in this document may not match the output you receive when running these commands. The outputs in this document are examples only.

### Catalyst RSM/VIP2 in Catalyst 5000 Family Switches

Following is an example of the **show interfaces** command, which displays status information (including the physical slot and interface address) for the interfaces you specify. In these examples, the eight serial interfaces (0 to 7) are on a port adapter in port adapter slot 1 of a Catalyst RSM/VIP2; also, most of the status information for each interface is omitted. (Interfaces are administratively shut down until you enable them.)

```
Router# show interfaces serial 1/0
Serial1/0 is up, line protocol is up
 Hardware is cyBus Serial
 Internet address is 10.10.10.0
 MTU 1500 bytes, BW 1544 Kbit, DLY 20000 usec, rely 255/255, load 1/255
 Encapsulation HDLC, loopback not set, keepalive not set
(display text omitted)
```

```
Router# show interfaces serial 1/1
Serial1/1 is up, line protocol is up
 Hardware is cyBus Serial
 Internet address is 10.10.10.1
 MTU 1500 bytes, BW 1544 Kbit, DLY 20000 usec, rely 255/255, load 1/255
 Encapsulation HDLC, loopback not set, keepalive not set
(display text omitted)
```

```
Router# show interfaces serial 1/2
Serial1/2 is up, line protocol is up
 Hardware is cyBus Serial
 Internet address is 10.10.10.2
 MTU 1500 bytes, BW 1544 Kbit, DLY 20000 usec, rely 255/255, load 1/255
 Encapsulation HDLC, loopback not set, keepalive not set
(display text omitted)
```

### Catalyst 6000 Family FlexWAN Module in Catalyst 6000 Family Switches

Following is an example of the **show interfaces serial** command, which shows all of the information specific to interface 0 on a PA-8T-X21 port adapter in port adapter bay 1 of a Catalyst 6000 family FlexWAN module in module slot 8:

```
Router# show interfaces serial 8/1/0
Serial8/1/0 is administratively down, line protocol is down
 Hardware is Serial
 MTU 1500 bytes, BW 1544 Kbit, DLY 20000 usec,
 reliability 255/255, txload 1/255, rxload 1/255
```

```

Encapsulation HDLC, crc 16, loopback not set
Keepalive not set
Last input never, output never, output hang never
Last clearing of "show interface" counters never
Queueing strategy: fifo
Output queue 0/40, 0 drops; input queue 0/75, 0 drops
5 minute input rate 0 bits/sec, 0 packets/sec
5 minute output rate 0 bits/sec, 0 packets/sec
 0 packets input, 0 bytes, 0 no buffer
 Received 0 broadcasts, 0 runts, 0 giants, 0 throttles
 0 input errors, 0 CRC, 0 frame, 0 overrun, 0 ignored, 0 abort
 0 packets output, 0 bytes, 0 underruns
 0 output errors, 0 collisions, 0 interface resets
 0 output buffer failures, 0 output buffers swapped out
 0 carrier transitions
RTS down, CTS down, DTR down, DCD down, DSR down

```

### Cisco 7200 Series, Cisco uBR7200 Series Routers, Cisco 7301 Router, and Cisco 7401ASR Routers

Following is an example of the **show interfaces serial** command, which shows all of the information specific to interface port 0 on a PA-8T-X21 port adapter installed in port adapter slot 1:

```

Router# show interfaces serial 1/0
Serial1/0 is up, line protocol is up
 Hardware is M8T-X.21
 MTU 1500 bytes, BW 1544 Kbit, DLY 20000 usec, rely 255/255, load 1/255
 Encapsulation HDLC, loopback not set, keepalive set (10 sec)
 Last input never, output 1d17h, output hang never
 Last clearing of "show interface" counters never
 Output queue 0/40, 0 drops; input queue 0/75, 0 drops
 5 minute input rate 0 bits/sec, 0 packets/sec
 5 minute output rate 0 bits/sec, 0 packets/sec
 0 packets input, 0 bytes, 0 no buffer
 Received 0 broadcasts, 0 runts, 0 giants
 0 input errors, 0 CRC, 0 frame, 0 overrun, 0 ignored, 0 abort
 24 packets output, 5137 bytes, 0 underruns
 0 output errors, 0 collisions, 0 interface resets
 0 output buffer failures, 0 output buffers swapped out
 0 carrier transitions DCD=down DSR=down DTR=down RTS=down CTS=down

```

### VIP in Cisco 7000 Series or Cisco 7500 Series Routers

Following is an example of the **show interfaces serial** command, which shows all of the information specific to interface 0 on a PA-8T-X21 port adapter in port adapter slot 1 of a VIP in interface processor slot 3:

```

Router# show interfaces serial 3/1/0
Serial3/1/0 is up, line protocol is up
 Hardware is cyBus Serial
 Internet address is 10.10.10.0
 MTU 1500 bytes, BW 1544 Kbit, DLY 20000 usec, rely 255/255, load 1/255
 Encapsulation HDLC, loopback not set, keepalive not set
 Last input 2d18h, output 00:00:54, output hang never
 Last clearing of "show interface" counters never
 Input queue: 0/75/0 (size/max/drops); Total output drops: 0
 Queueing strategy: weighted fair
 Output queue: 0/64/0 (size/threshold/drops)
 Conversations 0/1 (active/max active)
 Reserved Conversations 0/0 (allocated/max allocated)
 5 minute input rate 0 bits/sec, 0 packets/sec
 5 minute output rate 0 bits/sec, 0 packets/sec

```

```

16 packets input, 1620 bytes, 0 no buffer
 Received 0 broadcasts, 0 runts, 0 giants
 0 input errors, 0 CRC, 0 frame, 0 overrun, 1 ignored, 0 abort
3995 packets output, 1147800 bytes, 0 underruns
 0 output errors, 0 collisions, 0 interface resets
 0 output buffer failures, 0 output buffers swapped out
 1 carrier transitions
RTS up, CTS up, DTR up, DCD up, DSR up

```

## Using the ping Command to Verify Network Connectivity

Using the **ping** command, you can verify that an interface port is functioning properly. This section provides a brief description of this command. Refer to the publications listed in the “[Related Documentation](#)” section on page viii for detailed command descriptions and examples.

The **ping** command sends echo request packets out to a remote device at an IP address that you specify. After sending an echo request, the system waits a specified time for the remote device to reply. Each echo reply is displayed as an exclamation point (!) on the console terminal; each request that is not returned before the specified timeout is displayed as a period (.). A series of exclamation points (!!!!!) indicates a good connection; a series of periods (.....) or the messages [timed out] or [failed] indicates a bad connection.

Following is an example of a successful **ping** command to a remote server with the address 10.0.0.10:

```

Router# ping 10.0.0.10 <Return>
Type escape sequence to abort.
Sending 5, 100-byte ICMP Echoes to 10.0.0.10, timeout is 2 seconds:
!!!!
Success rate is 100 percent (5/5), round-trip min/avg/max = 1/15/64 ms
Router#

```

If the connection fails, verify that you have the correct IP address for the destination and that the device is active (powered on), and repeat the **ping** command.

## Using loopback Commands

The loopback test allows you to detect and isolate equipment malfunctions by testing the connection between the PA-8T-X21 interface and a remote device such as a modem or a CSU/DSU. The **loopback** subcommand places an interface in loopback mode, which enables test packets that are generated from the **ping** command to loop through a remote device or compact serial cable. If the packets complete the loop, the connection is good. If not, you can isolate a fault to the remote device or compact serial cable in the path of the loopback test.



### Note

You must configure a clock rate on the port *before* performing a loopback test. However, if no cable is attached to the port, the port is administratively up, and the port is in loopback mode; you do not have to configure a clock rate on the port *before* performing a loopback test.

Depending on the mode of the port, issuing the **loopback** command checks the following path:

- When no compact serial cable is attached to the PA-8T-X21 interface port, or if a DCE cable is attached to a port that is configured as line protocol up, the **loopback** command tests the path between the network processing engine and the interface port only (without leaving the network processing engine and port adapter).
- When a DTE cable is attached to the port, the **loopback** command tests the path between the network processing engine and the near (network processing engine) side of the DSU or modem to test the PA-8T-X21 interface and compact serial cable.

