



## T1/E1 Digital Voice Port Adapter Installation and Configuration

Product Numbers: PA-VXA-1TE1-24+(=), PA-VXA-1TE1-30+(=),  
PA-VXB-2TE1(=), PA-VXB-2TE1+(=), PA-VXC-2TE1(=), PA-VXC-2TE1+(=)

Platforms Supported: Cisco 7200 Series, Cisco 7200 VXR, Cisco 7301 Routers,  
Cisco 7401ASR Routers, and VIP in the Cisco 7500 Series

Corporate Headquarters  
Cisco Systems, Inc.  
170 West Tasman Drive  
San Jose, CA 95134-1706  
USA  
<http://www.cisco.com>  
Tel: 408 526-4000  
800 553-NETS (6387)  
Fax: 408 526-4100



THE SPECIFICATIONS AND INFORMATION REGARDING THE PRODUCTS IN THIS MANUAL ARE SUBJECT TO CHANGE WITHOUT NOTICE. ALL STATEMENTS, INFORMATION, AND RECOMMENDATIONS IN THIS MANUAL ARE BELIEVED TO BE ACCURATE BUT ARE PRESENTED WITHOUT WARRANTY OF ANY KIND, EXPRESS OR IMPLIED. USERS MUST TAKE FULL RESPONSIBILITY FOR THEIR APPLICATION OF ANY PRODUCTS.

THE SOFTWARE LICENSE AND LIMITED WARRANTY FOR THE ACCOMPANYING PRODUCT ARE SET FORTH IN THE INFORMATION PACKET THAT SHIPPED WITH THE PRODUCT AND ARE INCORPORATED HEREIN BY THIS REFERENCE. IF YOU ARE UNABLE TO LOCATE THE SOFTWARE LICENSE OR LIMITED WARRANTY, CONTACT YOUR CISCO REPRESENTATIVE FOR A COPY.

The following information is for FCC compliance of Class A devices: This equipment has been tested and found to comply with the limits for a Class A digital device, pursuant to part 15 of the FCC rules. These limits are designed to provide reasonable protection against harmful interference when the equipment is operated in a commercial environment. This equipment generates, uses, and can radiate radio-frequency energy and, if not installed and used in accordance with the instruction manual, may cause harmful interference to radio communications. Operation of this equipment in a residential area is likely to cause harmful interference, in which case users will be required to correct the interference at their own expense.

The following information is for FCC compliance of Class B devices: The equipment described in this manual generates and may radiate radio-frequency energy. If it is not installed in accordance with Cisco's installation instructions, it may cause interference with radio and television reception. This equipment has been tested and found to comply with the limits for a Class B digital device in accordance with the specifications in part 15 of the FCC rules. These specifications are designed to provide reasonable protection against such interference in a residential installation. However, there is no guarantee that interference will not occur in a particular installation.

Modifying the equipment without Cisco's written authorization may result in the equipment no longer complying with FCC requirements for Class A or Class B digital devices. In that event, your right to use the equipment may be limited by FCC regulations, and you may be required to correct any interference to radio or television communications at your own expense.

You can determine whether your equipment is causing interference by turning it off. If the interference stops, it was probably caused by the Cisco equipment or one of its peripheral devices. If the equipment causes interference to radio or television reception, try to correct the interference by using one or more of the following measures:

- Turn the television or radio antenna until the interference stops.
- Move the equipment to one side or the other of the television or radio.
- Move the equipment farther away from the television or radio.
- Plug the equipment into an outlet that is on a different circuit from the television or radio. (That is, make certain the equipment and the television or radio are on circuits controlled by different circuit breakers or fuses.)

Modifications to this product not authorized by Cisco Systems, Inc. could void the FCC approval and negate your authority to operate the product.

The Cisco implementation of TCP header compression is an adaptation of a program developed by the University of California, Berkeley (UCB) as part of UCB's public domain version of the UNIX operating system. All rights reserved. Copyright © 1981, Regents of the University of California.

NOTWITHSTANDING ANY OTHER WARRANTY HEREIN, ALL DOCUMENT FILES AND SOFTWARE OF THESE SUPPLIERS ARE PROVIDED "AS IS" WITH ALL FAULTS. CISCO AND THE ABOVE-NAMED SUPPLIERS DISCLAIM ALL WARRANTIES, EXPRESSED OR IMPLIED, INCLUDING, WITHOUT LIMITATION, THOSE OF MERCHANTABILITY, FITNESS FOR A PARTICULAR PURPOSE AND NONINFRINGEMENT OR ARISING FROM A COURSE OF DEALING, USAGE, OR TRADE PRACTICE.

IN NO EVENT SHALL CISCO OR ITS SUPPLIERS BE LIABLE FOR ANY INDIRECT, SPECIAL, CONSEQUENTIAL, OR INCIDENTAL DAMAGES, INCLUDING, WITHOUT LIMITATION, LOST PROFITS OR LOSS OR DAMAGE TO DATA ARISING OUT OF THE USE OR INABILITY TO USE THIS MANUAL, EVEN IF CISCO OR ITS SUPPLIERS HAVE BEEN ADVISED OF THE POSSIBILITY OF SUCH DAMAGES.

CCIP, the Cisco Arrow logo, the Cisco *Powered* Network mark, the Cisco Systems Verified logo, Cisco Unity, Follow Me Browsing, FormShare, iQ Breakthrough, iQ Expertise, iQ FastTrack, the iQ Logo, iQ Net Readiness Scorecard, Networking Academy, ScriptShare, SMARTnet, TransPath, and Voice LAN are trademarks of Cisco Systems, Inc.; Changing the Way We Work, Live, Play, and Learn, Discover All That's Possible, The Fastest Way to Increase Your Internet Quotient, and iQuick Study are service marks of Cisco Systems, Inc.; and Aironet, ASIST, BPX, Catalyst, CCDA, CCDP, CCIE, CCNA, CCNP, Cisco, the Cisco Certified Internetwork Expert logo, Cisco IOS, the Cisco IOS logo, Cisco Press, Cisco Systems, Cisco Systems Capital, the Cisco Systems logo, Empowering the Internet Generation, Enterprise/Solver, EtherChannel, EtherSwitch, Fast Step, GigaStack, Internet Quotient, IOS, IP/TV, LightStream, MGX, MICA, the Networkers logo, Network Registrar, *Packet*, PIX, Post-Routing, Pre-Routing, RateMUX, Registrar, SlideCast, StrataView Plus, Stratm, SwitchProbe, TeleRouter, and VCO are registered trademarks of Cisco Systems, Inc. and/or its affiliates in the U.S. and certain other countries.

All other trademarks mentioned in this document or Web site are the property of their respective owners. The use of the word partner does not imply a partnership relationship between Cisco and any other company. (0208R)

*T1/E1 Digital Voice Port Adapter Installation and Configuration*

Copyright © 1996–2003, Cisco Systems, Inc.

All rights reserved.



## **Preface vii**

Objectives	<b>vii</b>
Organization	<b>viii</b>
Related Documentation	<b>viii</b>
Obtaining Documentation	<b>ix</b>
Cisco.com	<b>ix</b>
Documentation CD-ROM	<b>x</b>
Ordering Documentation	<b>x</b>
Documentation Feedback	<b>x</b>
Obtaining Technical Assistance	<b>xi</b>
Cisco.com	<b>xi</b>
Technical Assistance Center	<b>xi</b>
Cisco TAC Website	<b>xi</b>
Cisco TAC Escalation Center	<b>xii</b>
Obtaining Additional Publications and Information	<b>xii</b>

---

## **CHAPTER 1**

### **Overview 1-1**

Port Adapter Overview	<b>1-1</b>
Features	<b>1-3</b>
LEDs	<b>1-5</b>
Cables, Connectors, and Pinouts	<b>1-5</b>
Port Adapter Slot Locations on the Supported Platforms	<b>1-6</b>
Cisco 7200 Series and Cisco 7200 VXR Routers Slot Numbering	<b>1-7</b>
Cisco 7301 Router Slot Numbering	<b>1-7</b>
Cisco 7401ASR Router Slot Numbering	<b>1-8</b>
VIP Slot Numbering	<b>1-8</b>
Identifying Interface Addresses	<b>1-9</b>
Cisco 7200 Series Routers Interface Addresses	<b>1-10</b>
Cisco 7301 Router Interface Addresses	<b>1-10</b>
Cisco 7401ASR Router Interface Addresses	<b>1-11</b>
Cisco 7500 Series Routers Interface Addresses	<b>1-11</b>

CHAPTER 2

**Preparing for Installation 2-1**

- Required Tools and Equipment 2-1
- Software and Hardware Requirements 2-2
- Checking Hardware and Software Compatibility 2-3
- Safety Guidelines 2-3
  - Safety Warnings 2-3
  - Electrical Equipment Guidelines 2-5
  - Telephone Wiring Guidelines 2-5
  - Preventing Electrostatic Discharge Damage 2-6
- FCC Class A Compliance 2-6

CHAPTER 3

**Removing and Installing Port Adapters 3-1**

- Handling Port Adapters 3-1
- Online Insertion and Removal 3-3
- Warnings and Cautions 3-4
  - Chassis Warning—Disconnecting Telephone-Network Cables 3-5
  - Lightning Activity Warning 3-5
  - Service Personnel Warning 3-6
  - No. 26 AWG Warning 3-7
  - Customer Equipment Warning 3-8
- Port Adapter Removal and Installation 3-9
  - Cisco 7200 Series—Removing and Installing a Port Adapter 3-10
  - Cisco 7301 Router—Removing and Installing a Port Adapter 3-11
  - Cisco 7401ASR Router—Removing and Installing a Port Adapter 3-12
  - Cisco 7500 Series—Removing and Installing an Interface Processor 3-13
  - VIP—Removing and Installing a Port Adapter 3-14
- Connecting Interface Cables 3-15

CHAPTER 4

**Configuring the PA-VXA, PA-VXB, and PA-VXC 4-1**

- Using the EXEC Command Interpreter 4-1
- Configuring the Interface 4-2
  - Shutting Down a Controller 4-2
  - Performing a Basic Configuration 4-4
    - Specifying Card Type is Required 4-4
- Configuring Voice over IP 4-6
  - Prerequisite Tasks 4-6
  - How VoIP Handles a Typical Telephone Call 4-7
  - Configuration Tasks 4-7

Configure IP Networks for Real-Time Voice Traffic	4-9
Configure RSVP for Voice	4-10
Configure Multilink PPP with Interleaving	4-11
Configure RTP Header Compression	4-12
Configure Custom Queuing	4-14
Configure Weighted Fair Queuing	4-14
Configure Number Expansion	4-14
Create a Number Expansion Table	4-15
Expand a Number	4-16
Configure Dial Peers	4-16
Inbound Versus Outbound Dial Peers	4-17
Create a Peer Configuration Table	4-18
Configure POTS Peers	4-19
Outbound Dialing on POTS Peers	4-19
Direct Inward Dial for POTS Peers	4-20
Configure VoIP Peers	4-21
Verify Configuration	4-22
Troubleshooting Tips	4-22
Configure Voice Ports	4-22
Configure FXO or FXS Voice Ports	4-23
Validation Tips	4-24
Troubleshooting Tips	4-24
Fine-Tune FXO and FXS Voice Ports	4-24
Configure E&M Voice Ports	4-26
Validation Tips	4-27
Troubleshooting Tips	4-27
Fine-Tune E&M Voice Ports	4-27
Optimize Dial Peer and Network Interface Configurations	4-29
Configure IP Precedence for Dial Peers	4-29
Configure RSVP for Dial Peers	4-30
Configure Codec and VAD for Dial Peers	4-31
Configuring Voice over Frame Relay	4-32
Voice over Frame Relay Configuration Example	4-33
Checking the Configuration	4-34
Using show Commands to Verify the New Interface Status	4-34
Troubleshooting Tips	4-34
Using the show version or show hardware Commands	4-35
Using the show diag Command	4-37
Using the show interfaces Command	4-40
Using loopback Commands	4-42

T1 Loopback Examples 4-42  
E1 Loopback Examples 4-44



## Preface

---

This preface describes the objectives and organization of this document and explains how to find additional information on related products and services. This preface contains the following sections:

- Objectives, page vii
- Organization, page viii
- Related Documentation, page viii
- Obtaining Documentation, page ix
- Obtaining Technical Assistance, page xi

## Objectives

This document describes how to install and configure the PA-VXA-1TE1 Low-Capacity Digital Voice port adapters (PA-VXA-1TE1-24+[=] and PA-VXA-1TE1-30+[=]), the PA-VXB-2TE1 Moderate-Capacity Digital Voice port adapter (PA-VXB-2TE1[=]), the PA-VXC-2TE1 High-Capacity Digital Voice port adapter (PA-VXC-2TE1[=]), the PA-VXB-2TE1+ Enhanced Moderate-Capacity Digital Voice port adapter (PA-VXB-2TE1+[=]) and the PA-VXC-2TE1+ Enhanced High-Capacity Digital Voice port adapter (PA-VXC-2TE1+[=]), hereafter referred to as the PA-VXA, PA-VXB, and PA-VXC. These port adapters are used in the following platforms:

- Cisco 7200 series routers, consisting of the two-slot Cisco 7202, the four-slot Cisco 7204 and Cisco 7204VXR, and the six-slot Cisco 7206 and Cisco 7206VXR
- Cisco 7301 router



---

**Note** The Cisco 7301 router is currently supported by the PA-VXB-2TE1+(=) and the PA-VXC-2TE1(=) port adapters only.

---

- Cisco 7401ASR router



---

**Note** The Cisco 7401ASR router is currently supported by the PA-VXB-2TE1+(=) and the PA-VXC-2TE1+(=) port adapters only.

---

- Versatile Interface Processor (VIP) in Cisco 7500 series routers, consisting of the five-slot Cisco 7505, the seven-slot Cisco 7507, and the thirteen-slot Cisco 7513

# Organization

This document contains the following chapters:

Section	Title	Description
Chapter 1	Overview	Describes the PA-VXA, PA-VXB, and PA-VXC, and their LED displays, cables, and receptacles.
Chapter 2	Preparing for Installation	Describes safety considerations, tools required, and procedures you should perform before the actual installation.
Chapter 3	Removing and Installing Port Adapters	Describes the procedures for installing and removing the PA-VXA, PA-VXB, and PA-VXC in the supported platforms.
Chapter 4	Configuring the PA-VXA, PA-VXB, and PA-VXC	Provides instructions for configuring the PA-VXA, PA-VXB, and PA-VXC on the supported platforms.

## Related Documentation

Your router or switch and the Cisco IOS software running on it contain extensive features and functionality, which are documented in the following resources:

- Cisco IOS software:

For configuration information and support, refer to the modular configuration and modular command reference publications in the Cisco IOS software configuration documentation set that corresponds to the software release installed on your Cisco hardware.



**Note** You can access Cisco IOS software configuration and hardware installation and maintenance documentation on the World Wide Web at <http://www.cisco.com>, <http://www-china.cisco.com>, or <http://www-europe.cisco.com>.

- Cisco 7200 series routers:
  - For port adapter hardware and memory configuration guidelines, refer to the *Cisco 7200 Series Port Adapter Hardware Configuration Guidelines*.
  - For hardware installation and maintenance information, refer to the installation and configuration guide that shipped with your Cisco 7200 series router.
  - For information on network processing engines or network services engines, refer to the *Network Processing Engine and Network Services Engine Installation and Configuration* publication.
- Cisco 7200 VXR routers:
 

For hardware installation and maintenance information, refer to the *Cisco 7200 VXR Installation and Configuration Guide* that shipped with your Cisco 7200 VXR router.



- Cisco 7301 routers:  
For hardware installation and maintenance information, refer to the *Cisco 7301 Installation and Configuration Guide* or the *Cisco 7301 Router Quick Start Guide*.
- Cisco 7401ASR routers:  
For hardware installation and maintenance information, refer to the *Cisco 7401ASR Installation and Configuration Guide* or the *Cisco 7401ASR Quick Start Guide*.
- Cisco 7500 series routers:  
For hardware installation and maintenance information, refer to the following publications:
  - *Cisco 7500 Installation and Configuration* or the quick start guide that shipped with your router
  - *Second-Generation Versatile Interface Processor (VIP2) Installation and Configuration*
  - *Fourth-Generation Versatile Interface Processor (VIP4) Installation and Configuration*
  - *Versatile Interface Processor (VIP6-80) Installation and Configuration*
- For international agency compliance, safety, and statutory information for WAN interfaces:
  - *Site Preparation and Safety Guide*
  - *Regulatory Compliance and Safety Information for the Cisco 7200 Series Routers*
  - *Cisco 7300 Series Internet Routers Regulatory Compliance and Safety Information*
  - *Cisco 7401ASR Regulatory Compliance and Safety Information*
  - *Regulatory Compliance and Safety Information for the Cisco 7500 Series Routers*
- To view Cisco documentation or obtain general information about the documentation, refer to the following sources:
  - “Obtaining Documentation” section on page ix.
  - “Obtaining Technical Assistance” section on page xi.
  - Customer service at 800 553-6387 or 408 526-7208. Customer service hours are 5:00 a.m. to 6:00 p.m. Pacific time, Monday through Friday (excluding Cisco-observed holidays).
  - *Cisco Information Packet* that shipped with your router or switch.

## Obtaining Documentation

Cisco provides several ways to obtain documentation, technical assistance, and other technical resources. These sections explain how to obtain technical information from Cisco Systems.

### Cisco.com

You can access the most current Cisco documentation on the World Wide Web at this URL:

<http://www.cisco.com/univercd/home/home.htm>

You can access the Cisco website at this URL:

<http://www.cisco.com>

International Cisco web sites can be accessed from this URL:

[http://www.cisco.com/public/countries\\_languages.shtml](http://www.cisco.com/public/countries_languages.shtml)

## Documentation CD-ROM

Cisco documentation and additional literature are available in a Cisco Documentation CD-ROM package, which may have shipped with your product. The Documentation CD-ROM is updated monthly and may be more current than printed documentation. The CD-ROM package is available as a single unit or through an annual subscription.

Registered Cisco.com users can order the Documentation CD-ROM (product number DOC-CONDOCCD=) through the online Subscription Store:

<http://www.cisco.com/go/subscription>

## Ordering Documentation

You can find instructions for ordering documentation at this URL:

[http://www.cisco.com/univercd/cc/td/doc/es\\_inpk/pdi.htm](http://www.cisco.com/univercd/cc/td/doc/es_inpk/pdi.htm)

You can order Cisco documentation in these ways:

- Registered Cisco.com users (Cisco direct customers) can order Cisco product documentation from the Networking Products MarketPlace:

<http://www.cisco.com/en/US/partner/ordering/index.shtml>

- Registered Cisco.com users can order the Documentation CD-ROM (Customer Order Number DOC-CONDOCCD=) through the online Subscription Store:

<http://www.cisco.com/go/subscription>

- Nonregistered Cisco.com users can order documentation through a local account representative by calling Cisco Systems Corporate Headquarters (California, U.S.A.) at 408 526-7208 or, elsewhere in North America, by calling 800 553-NETS (6387).

## Documentation Feedback

You can submit comments electronically on Cisco.com. On the Cisco Documentation home page, click **Feedback** at the top of the page.

You can e-mail your comments to [bug-doc@cisco.com](mailto:bug-doc@cisco.com).

You can submit your comments by mail by using the response card behind the front cover of your document or by writing to the following address:

Cisco Systems  
Attn: Customer Document Ordering  
170 West Tasman Drive  
San Jose, CA 95134-9883

We appreciate your comments.

# Obtaining Technical Assistance

Cisco provides Cisco.com, which includes the Cisco Technical Assistance Center (TAC) Website, as a starting point for all technical assistance. Customers and partners can obtain online documentation, troubleshooting tips, and sample configurations from the Cisco TAC website. Cisco.com registered users have complete access to the technical support resources on the Cisco TAC website, including TAC tools and utilities.

## Cisco.com

Cisco.com offers a suite of interactive, networked services that let you access Cisco information, networking solutions, services, programs, and resources at any time, from anywhere in the world.

Cisco.com provides a broad range of features and services to help you with these tasks:

- Streamline business processes and improve productivity
- Resolve technical issues with online support
- Download and test software packages
- Order Cisco learning materials and merchandise
- Register for online skill assessment, training, and certification programs

To obtain customized information and service, you can self-register on Cisco.com at this URL:

<http://www.cisco.com>

## Technical Assistance Center

The Cisco TAC is available to all customers who need technical assistance with a Cisco product, technology, or solution. Two levels of support are available: the Cisco TAC website and the Cisco TAC Escalation Center. The avenue of support that you choose depends on the priority of the problem and the conditions stated in service contracts, when applicable.

We categorize Cisco TAC inquiries according to urgency:

- Priority level 4 (P4)—You need information or assistance concerning Cisco product capabilities, product installation, or basic product configuration.
- Priority level 3 (P3)—Your network performance is degraded. Network functionality is noticeably impaired, but most business operations continue.
- Priority level 2 (P2)—Your production network is severely degraded, affecting significant aspects of business operations. No workaround is available.
- Priority level 1 (P1)—Your production network is down, and a critical impact to business operations will occur if service is not restored quickly. No workaround is available.

## Cisco TAC Website

You can use the Cisco TAC website to resolve P3 and P4 issues yourself, saving both cost and time. The site provides around-the-clock access to online tools, knowledge bases, and software. To access the Cisco TAC website, go to this URL:

<http://www.cisco.com/tac>

All customers, partners, and resellers who have a valid Cisco service contract have complete access to the technical support resources on the Cisco TAC website. Some services on the Cisco TAC website require a Cisco.com login ID and password. If you have a valid service contract but do not have a login ID or password, go to this URL to register:

<http://tools.cisco.com/RPF/register/register.do>

If you are a Cisco.com registered user, and you cannot resolve your technical issues by using the Cisco TAC website, you can open a case online at this URL:

<http://www.cisco.com/en/US/support/index.html>

If you have Internet access, we recommend that you open P3 and P4 cases through the Cisco TAC website so that you can describe the situation in your own words and attach any necessary files.

## Cisco TAC Escalation Center

The Cisco TAC Escalation Center addresses priority level 1 or priority level 2 issues. These classifications are assigned when severe network degradation significantly impacts business operations. When you contact the TAC Escalation Center with a P1 or P2 problem, a Cisco TAC engineer automatically opens a case.

To obtain a directory of toll-free Cisco TAC telephone numbers for your country, go to this URL:

<http://www.cisco.com/warp/public/687/Directory/DirTAC.shtml>

Before calling, please check with your network operations center to determine the level of Cisco support services to which your company is entitled: for example, SMARTnet, SMARTnet Onsite, or Network Supported Accounts (NSA). When you call the center, please have available your service agreement number and your product serial number.

## Obtaining Additional Publications and Information

Information about Cisco products, technologies, and network solutions is available from various online and printed sources.

- The *Cisco Product Catalog* describes the networking products offered by Cisco Systems as well as ordering and customer support services. Access the *Cisco Product Catalog* at this URL:

[http://www.cisco.com/en/US/products/products\\_catalog\\_links\\_launch.html](http://www.cisco.com/en/US/products/products_catalog_links_launch.html)

- Cisco Press publishes a wide range of networking publications. Cisco suggests these titles for new and experienced users: *Internetworking Terms and Acronyms Dictionary*, *Internetworking Technology Handbook*, *Internetworking Troubleshooting Guide*, and the *Internetworking Design Guide*. For current Cisco Press titles and other information, go to Cisco Press online at this URL:

<http://www.ciscopress.com>

- *Packet* magazine is the Cisco monthly periodical that provides industry professionals with the latest information about the field of networking. You can access *Packet* magazine at this URL:

[http://www.cisco.com/en/US/about/ac123/ac114/about\\_cisco\\_packet\\_magazine.html](http://www.cisco.com/en/US/about/ac123/ac114/about_cisco_packet_magazine.html)

- *iQ Magazine* is the Cisco monthly periodical that provides business leaders and decision makers with the latest information about the networking industry. You can access *iQ Magazine* at this URL:

[http://business.cisco.com/prod/tree.taf%3fasset\\_id=44699&public\\_view=true&kbns=1.html](http://business.cisco.com/prod/tree.taf%3fasset_id=44699&public_view=true&kbns=1.html)

- *Internet Protocol Journal* is a quarterly journal published by Cisco Systems for engineering professionals involved in the design, development, and operation of public and private internets and intranets. You can access the *Internet Protocol Journal* at this URL:

[http://www.cisco.com/en/US/about/ac123/ac147/about\\_cisco\\_the\\_internet\\_protocol\\_journal.html](http://www.cisco.com/en/US/about/ac123/ac147/about_cisco_the_internet_protocol_journal.html)

- Training—Cisco offers world-class networking training, with current offerings in network training listed at this URL:

[http://www.cisco.com/en/US/learning/le31/learning\\_recommended\\_training\\_list.html](http://www.cisco.com/en/US/learning/le31/learning_recommended_training_list.html)

The Cisco TAC Escalation Center addresses priority level 1 or priority level 2 issues. These classifications are assigned when severe network degradation significantly impacts business operations. When you contact the TAC Escalation Center with a P1 or P2 problem, a Cisco TAC engineer automatically opens a case.

To obtain a directory of toll-free Cisco TAC telephone numbers for your country, go to this URL:

<http://www.cisco.com/warp/public/687/Directory/DirTAC.shtml>

Before calling, please check with your network operations center to determine the level of Cisco support services to which your company is entitled: for example, SMARTnet, SMARTnet Onsite, or Network Supported Accounts (NSA). When you call the center, please have available your service agreement number and your product serial number.





## Overview

---

This chapter describes the PA-VXA, PA-VXB, and PA-VXC port adapters and contains the following sections:

- Port Adapter Overview, page 1-1
- Features, page 1-3
- LEDs, page 1-5
- Cables, Connectors, and Pinouts, page 1-5
- Port Adapter Slot Locations on the Supported Platforms, page 1-6
- Identifying Interface Addresses, page 1-9

## Port Adapter Overview

The PA-VXA-1TE1-24+(=) (see Figure 1-1) is a single port T1/E1 voice port adapter with seven active digital signal processors (DSPs). This PA-VXA can support up to 28 simultaneous medium-complexity codec (G.729a, G.726, or G.711) voice channels—enough channels to support a single T1 or E1 line.

**Figure 1-1** PA-VXA-1TE1-24+ Port Adapter



The PA-VXA-1TE1-30+(=) (see Figure 1-2) is a single port T1/E1 voice port adapter with eight active DSPs. This PA-VXA can support up to 32 simultaneous medium-complexity codec (G.729a, G.726, or G.711) voice channels—enough channels to support a single T1 or E1 line.

**Figure 1-2 PA-VXA-1TE1-30+ Port Adapter**

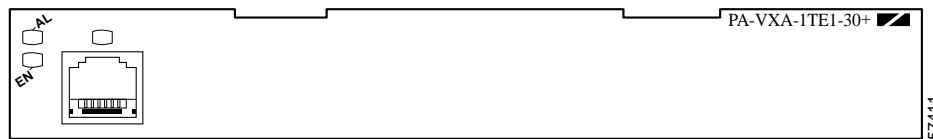

The PA-VXAs are single-width port adapters with one universal port that is configurable for either a T1 or E1 connection. Using a PA-VXA packet voice port adapter, Cisco 7200 series routers, Cisco 7200 VXR routers, and Cisco 7500 series routers can become dedicated packet voice hubs or packet voice gateways that connect to both private branch exchanges (PBXs) and the Public Switched Telephone Network (PSTN). The result is that packet voice and packet fax calls can be placed over the wide-area network (WAN) and sent through the gateway into a traditional circuit-switched voice infrastructure.

The PA-VXB and the PA-VXC (see Figure 1-3 and Figure 1-4) are multichannel packet voice port adapters that allow Cisco 7200 series routers, Cisco 7200 VXR routers, Cisco 7301 routers, Cisco 7401 ASR routers, and Cisco 7500 series routers to become dedicated packet voice hubs or packet voice gateways that connect to both private branch exchanges (PBXs) and the Public Switched Telephone Network (PSTN). With this technology, packet voice and packet fax calls can be placed over the wide-area network (WAN) and sent through the gateway into the traditional circuit-switched voice infrastructure.

**Figure 1-3 PA-VXB-2TE1 Port Adapter**



**Figure 1-4 PA-VXC-2TE1 Port Adapter**



The PA-VXB and PA-VXC are single-width port adapters with two universal ports that are configurable for either T1 or E1 connections. The PA-VXB contains 12 high-performance digital signal processors (DSPs) that support up to 48 medium-complexity or 24 high-complexity channels of compressed voice. The PA-VXC contains 30 high-performance DSPs that support up to 120 medium-complexity or 60 high-complexity channels of compressed voice.

In Voice over IP, the DSP segments the voice signal into frames, which are then coupled in groups of two and stored in voice packets. These voice packets are transported using IP in compliance with ITU-T specification H.323. Because Voice over IP is a delay-sensitive application, you must have a well-engineered end-to-end network to use it successfully. Fine-tuning your network to adequately



support Voice over IP involves a series of protocols and features geared toward quality of service (QoS). Traffic shaping considerations must be taken into account to ensure the reliability of the voice connection.

## Features

The PA-VXA, PA-VXB, and PA-VXC have the following features:

- Universal ports—One interface port (PA-VXA) or two interface ports (PA-VXB and PA-VXC) per port adapter are configurable as either T1 (with integrated CSU/DSU) or E1 (with integrated G.703/G.704 120-ohm interface). Additionally, a port may be configured on a per-DS0 basis for voice termination, time-division multiplexing (TDM) pass-through (cross-connect), or packet data.
- High-density digital signal processor (DSP) technology—Full support exists for low-bit-rate voice compression (down to 5.3 kbps) on all T1/E1 port channels.
- Multiservice Interchange (MIX) support—Voice channels can be TDM-switched between port adapter slots in the Cisco 7200 VXR chassis. This allows DSP resources to be shared between port adapters in the same chassis or for port-to-port DS0 cross-connect between port adapter slots.
- DS0 drop and insert—Flexible TDM cross-connect capability between ports and the MIX bus is available.
- VoIP and VoFR termination—Full VoIP and Voice over Frame Relay (VoFR) gateway functionality for mixed environments is available.
- Full-featured DSP firmware—Support exists for eight standard-compression algorithms plus echo cancellation, full dual tone multifrequency (DTMF)/MF tone detection and generation, and dial-pulse generation.
- Silence suppression—To conserve network bandwidth, voice activity detection (VAD) prevents sending data when no voice is present. Comfort-noise generation prevents uncomfortable dead silence on the receiving end.
- Multiple clocking options—Ports can be clocked internally from the network, or the network clock from one port can be sent to the other port on the card or to other cards across the MIX bus in the VXR chassis.
- Flexible signaling support—Channel-associated signaling (CAS) and common channel signaling (CCS) support is available for both E1 and T1 applications in H.323 environments.

### DSP features:

- Coders/decoders (codecs):  
G.711 (a-law/u-law), G.729/G.729.a (with b variant), G.723.1, G.728, G.726
- Fax relay through T.30 support:  
V.17, V.29, V.27
- Echo cancellation—32 milliseconds meeting G.165
- DTMF/R2/MF/SF/CP tone detection and generation
- Dial-pulse detection and generation
- Energy-based voice activity detection (VAD) and codec-specific VAD
- Comfort noise generator

**Signaling supported for H.323 environments:**

- H.323 V.2 support
- E1 CAS, T1 CAS (robbed-bit signaling)
- CCS signaling—E1 and T1 PRI (user and network side), Q.SIG
- R2 signaling

**Port configured as T1 features:**

- DS1 100-ohm interfaces with RJ-45 connectors
- D4 super frame (SF) and extended super frame (ESF) framing
- Alternate mark inversion (AMI) or binary 8-zero substitution (B8ZS) line encoding
- Full Facility Data Link (FDL) support and FDL performance monitoring per ANSI T1.403 or AT&T TR 54016
- Selectable DSX-1 cable length in increments from 0 to 655 feet (0 to 79.64 meters)
- Selectable DS1 CSU line build-out—0, -7.5, -15, or -22.5 dB
- Selectable DS1 CSU receiver gain—26 or 36 dB
- DS1 line protection per UL1459/1950, FCC part 68
- Full support for DSX-1 Management Information Base (MIB), RFC 1406, including alarm detection and reporting
- DSX-1 MIB remote access supported

**Port configured as E1 features:**

- E1 120-ohm (G.703) with RJ-48C connectors
- Software-configurable E1 national bits
- Binary 3-zero substitution (B3ZS) encoding
- Full support for E1 MIB, RFC 1406, including alarm detection and reporting

**Full bit-error-rate testing capabilities on each E1/T1:**

- Programmable pseudorandom pattern up to 24 bits in length, including 211-1, 215-1, 220-1, 220-1 QRSS, 233-1, all zeros, all ones, and alternating ones and zeros
- 32-bit-error count registers

**Supported loopbacks:**

- Line loopback—T1/E1 stream is looped back at the line interface unit (LIU) toward the network.
- Payload loopback—T1/E1 data stream is looped back at the framer toward the network.
- Diagnostic local loopback—T1/E1 data stream is looped back at the framer toward the system.
- Remote loopback—T1 stream is looped back at the LIU toward the network upon request from the far-end through the FDL command.

## LEDs

As shown in Figure 1-1 and Figure 1-2, the PA-VXAs have three LEDs on the faceplates; a green enabled LED, a bicolor alarm LED, and a bicolor port status LED. Table 1-1 lists the colors and functions of the LEDs.

As shown in Figure 1-3 and Figure 1-4, the PA-VXB and PA-VXC port adapters have four LEDs on the faceplate: a green enabled LED, a bicolor alarm LED, and two bicolor port status LEDs, one for each port. Table 1-1 lists the colors and functions of the LEDs.

**Table 1-1 PA-VXA, PA-VXB, and PA-VXC Port Adapter LEDs**

LED Label	Color	State	Function	
EN		On	Indicates the PA-VXA, PA-VXB, and PA-VXC port adapters are powered up.	
		Off	Indicates the PA-VXA, PA-VXB, and PA-VXC port adapters are not ready or disabled.	
AL	Amber	On	Indicates an alarm condition exists on the remote end of one of the T1/E1 ports.	
		Red	On	Indicates an alarm condition exists locally on one of the T1/E1 ports.
		Off	Indicates no alarms detected on either port.	
Unlabeled, 0, or 1	Green	On	Indicates the port is enabled.	
		Yellow	On	Indicates the port is in loopback.
		Off	Indicates that the port is not enabled, the received signal is bad, or an alarm condition exists.	

## Cables, Connectors, and Pinouts

The T1/E1 interface receptacles on the PA-VXA, PA-VXB, and PA-VXC port adapters are for RJ-45 connectors for both T1 (100 ohm) and E1 (120 ohm).

After you properly connect a port to a line, it takes approximately 30 seconds for the Cisco IOS to report that the line is up.

Each connection supports T1(100-ohm) or E1(120-ohm) interfaces that meet T1.403 and ACCUNET TR62411 standards. The RJ-45 connection does not require an external transceiver. The DS1 ports are T1 interfaces that use foil twisted-pair cables.

Shielded cables (foil twisted-pair [FTP]) with 120-ohm impedance are required to comply with CE marking requirements.

Figure 1-5 shows the PA-VXA, PA-VXB, and PA-VXC port adapter interface cable connector. See the “Connecting Interface Cables” section on page 3-15 for directions on connecting the cables to a PA-VXA, PA-VXB, or PA-VXC.

**Figure 1-5** PA-VXA, PA-VXB, and PA-VXC Port Adapter Interface Connector

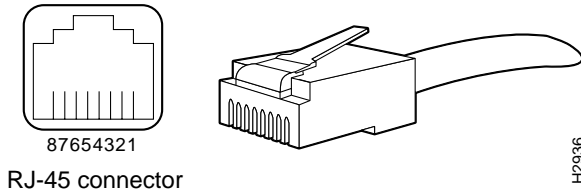

Table 1-2 lists the signal pinouts and descriptions for the RJ-45 connector.

**Table 1-2** RJ-45 Connector Pinouts

Pin	Signal
1	RX tip
2	RX ring
3	No connection
4	TX tip
5	TX ring
6	No connection
7	No connection
8	No connection

## Port Adapter Slot Locations on the Supported Platforms

This section discusses port adapter slot locations on the supported platforms. The illustrations that follow summarize slot location conventions on each platform:

- Cisco 7200 Series and Cisco 7200 VXR Routers Slot Numbering, page 1-7
- Cisco 7301 Router Slot Numbering, page 1-7
- Cisco 7401ASR Router Slot Numbering, page 1-8
- VIP Slot Numbering, page 1-8

## Cisco 7200 Series and Cisco 7200 VXR Routers Slot Numbering

Figure 1-6 shows a Cisco 7206 with port adapters installed. In the Cisco 7206, port adapter slot 1 is in the lower left position, and port adapter slot 6 is in the upper right position. (The Cisco 7202 and Cisco 7204 are not shown; however, the PA-VXA, PA-VXB, and PA-VXC port adapters can be installed in any available port adapter slot. Slot 0 is always reserved for the Fast Ethernet port on the I/O controller—if present.)

**Figure 1-6** Port Adapter Slots in the Cisco 7206

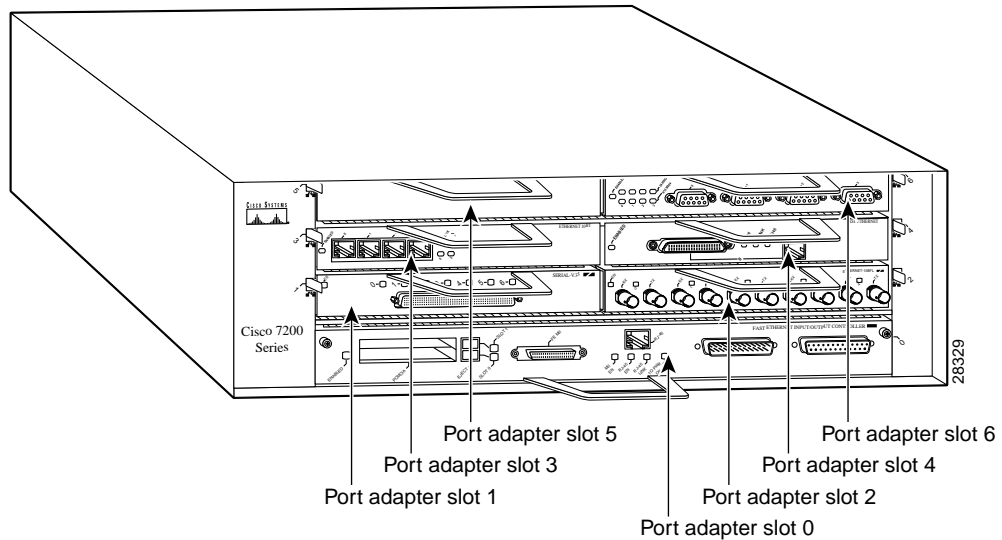

## Cisco 7301 Router Slot Numbering

The Cisco 7301 router has one port adapter slot. See Figure 1-7.

**Figure 1-7** Port Adapter Slot on the Cisco 7301 Router

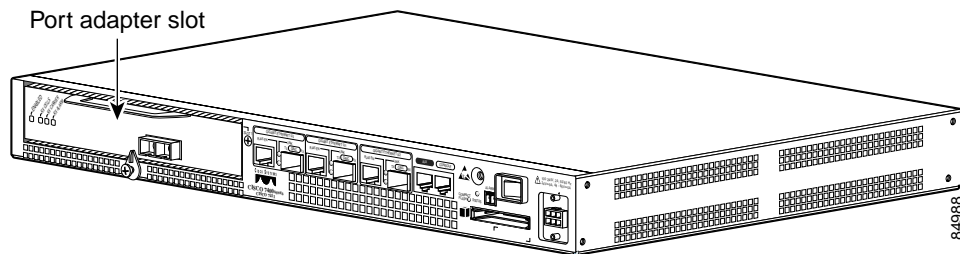

**Note**

The Cisco 7301 router is currently supported by the PA-VXB-2TE1+(=) and the PA-VXC-2TE1(=) port adapters only.

## Cisco 7401ASR Router Slot Numbering

Figure 1-8 shows the front view of the Cisco 7401ASR router with a port adapter installed. There is only one port adapter slot in a Cisco 7401ASR router and it is port adapter slot 1.

**Figure 1-8** Cisco 7401ASR Router with a Port Adapter Installed

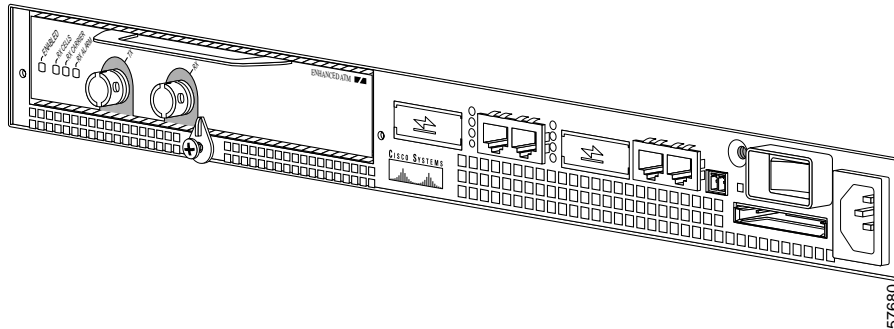

### Note

The Cisco 7401ASR router is currently supported by the PA-VXB-2TE1+(=) and the PA-VXC-2TE1+(=) port adapters only.

## VIP Slot Numbering

Figure 1-9 shows a partial view of a VIP motherboard with installed port adapters that would be used with a Cisco 7500 series router. With the motherboard oriented as shown in Figure 1-9, the left port adapter is in port adapter slot 0, and the right port adapter is in port adapter slot 1. The slots are always numbered 0 and 1.

**Figure 1-9** VIP Motherboard with Two Port Adapters Installed—Horizontal Orientation

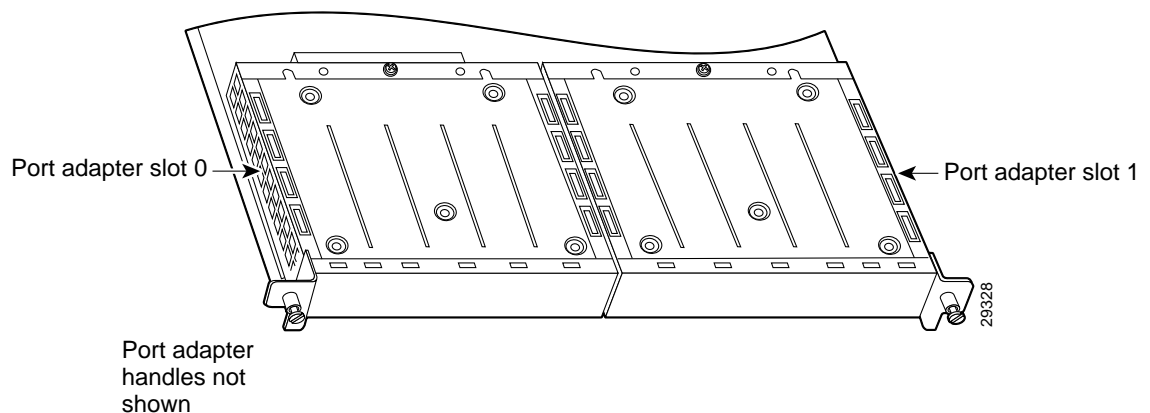

### Note

In the Cisco 7507, and Cisco 7513 chassis, the VIP motherboard is installed vertically. In the Cisco 7505 chassis, the VIP motherboard is installed horizontally as shown in Figure 1-10.

Interface processor slots are numbered as shown in Figure 1-10.

**Figure 1-10 Interface Slot Numbers—Cisco 7505 Shown**

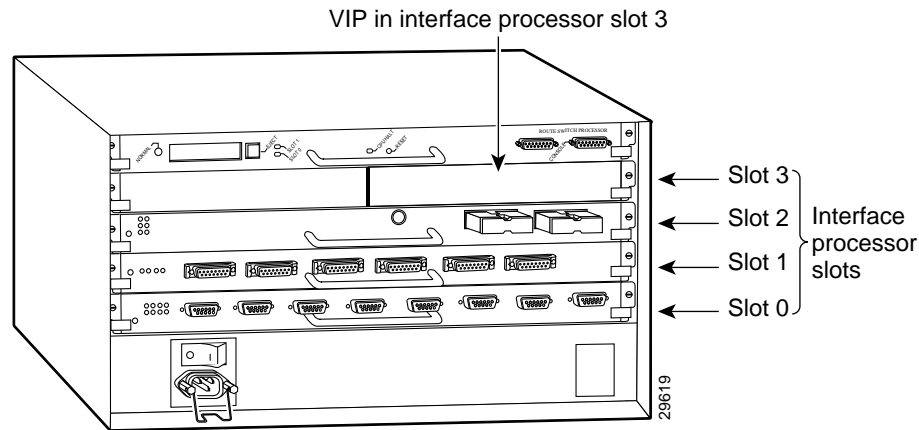

## Identifying Interface Addresses

This section describes how to identify interface addresses for the PA-VXA, PA-VXB, and PA-VXC port adapters in supported platforms. Interface addresses specify the actual physical location of each interface on a router or switch.

Interfaces on the PA-VXA, PA-VXB, and PA-VXC port adapters installed in a router maintain the same address regardless of whether other port adapters are installed or removed. However, when you move a port adapter to a different slot, the first number in the interface address changes to reflect the new port adapter slot number.



**Note**

Interface ports are numbered from left to right starting with 0.

Table 1-3 explains how to identify interface addresses.

**Table 1-3 Identifying Interface Addresses**

Platform	Interface Address Format	Numbers	Syntax
Cisco 7200 series and Cisco 7200 VXR routers	Port-adapter-slot-number/interface-port-number	Port adapter slot—1 through 6 (depends on the number of slots in the router) <sup>1</sup> Interface port—0 or 1	1/0
Cisco 7301 routers <sup>2</sup>	Port-adapter-slot-number/interface-port-number	Port adapter slot—always 1 Interface port—0 or 1	1/0

Table 1-3 Identifying Interface Addresses (continued)

Platform	Interface Address Format	Numbers	Syntax
Cisco 7401ASR routers <sup>3</sup>	Port-adapter-slot-number/interface-port-number	Port adapter slot—always 1 Interface port—0 or 1	1/0
VIP in Cisco 7500 series routers	Interface-processor-slot-number/port-adapter-slot-number/interface-port-number	Interface processor slot—0 through 12 (depends on the number of slots in the router) Port adapter slot—always 0 or 1 Interface port—0 or 1	3/0/0

1. Port adapter slot 0 is reserved for the Fast Ethernet port on the I/O controller (if present).
2. The Cisco 7301 router is currently supported by the PA-VXB-2TE1(=) and the PA-VXC-2TE1(=) port adapters only.
3. The Cisco 7401ASR router is currently supported by the PA-VXB-2TE1+(=) and the PA-VXC-2TE1+(=) port adapters only.

## Cisco 7200 Series Routers Interface Addresses

This section describes how to identify the interface addresses used for the PA-VXA, PA-VXB, and PA-VXC port adapters in Cisco 7200 series and Cisco 7200 VXR routers. The interface address is composed of a two-part number in the format *port-adapter-slot-number/interface-port-number*. See Table 1-3 for the interface address format.

In Cisco 7200 series and Cisco 7200 VXR routers, port adapter slots are numbered from the lower left to the upper right, beginning with port adapter slot 1 and continuing through port adapter slot 2 for the Cisco 7202, slot 4 for the Cisco 7204 and Cisco 7204VXR, and slot 6 for the Cisco 7206 and Cisco 7206VXR. (Port adapter slot 0 is reserved for the optional Fast Ethernet port on the I/O controller—if present.)

## Cisco 7301 Router Interface Addresses

This section describes how to identify the interface addresses used for the the PA-VXB-2TE1+(=) or the PA-VXC-2TE1(=) in a Cisco 7301 router. In the Cisco 7301 router, slot 1 is the port adapter slot you use for any of these two port adapters. (See Figure 1-7.) The interface address is composed of a two-part number in the format *port-adapter-slot-number/interface-port-number*. See Table 1-3 for the interface address format.



### Note

The Cisco 7301 router is currently supported by the PA-VXB-2TE1+(=) and the PA-VXC-2TE1(=) port adapters only.



## Cisco 7401ASR Router Interface Addresses

This section describes how to identify the interface addresses used for the the PA-VXB-2TE1+(=) or the PA-VXC-2TE1+(=) in a Cisco 7401ASR router. In the Cisco 7401ASR router, slot 1 is the port adapter slot you use for any of these two port adapters. (See Figure 1-8.) The interface address is composed of a two-part number in the format *port-adapter-slot-number/interface-port-number*. See Table 1-3 for the interface address format.

**Note**

---

The Cisco 7401ASR router is currently supported by the PA-VXB-2TE1+(=) and the PA-VXC-2TE1+(=) port adapters only.

---

## Cisco 7500 Series Routers Interface Addresses

This section describes how to identify the interface addresses used for the PA-VXA, PA-VXB, and PA-VXC on a VIP in Cisco 7500 series routers.

**Note**

---

Although the processor slots in the seven-slot Cisco 7507 and the thirteen-slot Cisco 7513 and Cisco 7576 are vertically oriented and those in the five-slot Cisco 7505 are horizontally oriented, all Cisco 7500 series routers use the same method for slot and port numbering.

---

The interface address is composed of a three-part number in the format *interface-processor-slot-number/port-adapter-slot-number/interface-port-number*. See Table 1-3 for the interface address format.





## Preparing for Installation

---

This chapter describes the general equipment, safety, and site preparation requirements for installing the PA-VXA, PA-VXB, and PA-VXC port adapters. This chapter contains the following sections:

- Required Tools and Equipment, page 2-1
- Software and Hardware Requirements, page 2-2
- Checking Hardware and Software Compatibility, page 2-3
- Safety Guidelines, page 2-3
- FCC Class A Compliance, page 2-6

## Required Tools and Equipment

You need the following tools and parts to install a port adapter. If you need additional equipment, contact a service representative for ordering information.

- PA-VXA-1TE1-24+(=), PA-VXA-1TE1-30+(=), PA-VXB-2TE1(=), PA-VXB-2TE1+(=), PA-VXC-2TE1(=), or PA-VXC-2TE1+(=) port adapter
- Shielded cables (foil twisted-pair [FTP]) with 120-ohm impedance (for E1 connections only)



---

**Note** To comply with Conducted Susceptibility of the CE marking requirements, shielded 120-ohm (screened) cables should be used with this board.

---

- Number 2 Phillips screwdriver
- Your own electrostatic discharge (ESD)-prevention equipment or the disposable grounding wrist strap included with all upgrade kits, field-replaceable units (FRUs), and spares
- Antistatic mat
- Antistatic container

# Software and Hardware Requirements

Table 2-1 lists the recommended minimum Cisco IOS software release required to use the PA-VXA, PA-VXB, and PA-VXC port adapters in the supported router platforms.

**Table 2-1 PA-VXA, PA-VXB, and PA-VXC Software and Hardware Requirements**

Port Adapters on Supported Platforms	Recommended Minimum Cisco IOS Release
<b>PA-VXA-1TE1-24+</b>	
<ul style="list-style-type: none"> <li>Cisco 7200 series and Cisco 7200 VXR routers</li> </ul>	Cisco IOS Release 12.2(4)T or a later release of Cisco IOS Release 12.2 T Cisco IOS Release 12.2(4)B or a later release of Cisco IOS Release 12.2 B
<ul style="list-style-type: none"> <li>Cisco 7500 series routers with VIP<sup>1, 2</sup></li> </ul>	Cisco IOS Release 12.2(4)T or a later release of Cisco IOS Release 12.2 T
<b>PA-VXA-1TE1-30+</b>	
<ul style="list-style-type: none"> <li>Cisco 7200 series and Cisco 7200 VXR routers</li> </ul>	Cisco IOS Release 12.2(4)T or a later release of Cisco IOS Release 12.2 T Cisco IOS Release 12.2(4)B or a later release of Cisco IOS Release 12.2 B
<ul style="list-style-type: none"> <li>Cisco 7500 series routers with VIP<sup>1, 2</sup></li> </ul>	Cisco IOS Release 12.2(4)T or a later release of Cisco IOS Release 12.2 T
<b>PA-VXB-2TE1</b>	
<ul style="list-style-type: none"> <li>Cisco 7200 series and Cisco 7200 VXR routers</li> </ul>	Cisco IOS Release 12.1(3)T or an earlier release of Cisco IOS Release 12.1 T
<b>PA-VXB-2TE1+</b>	
<ul style="list-style-type: none"> <li>Cisco 7200 series and Cisco 7200 VXR routers</li> </ul>	Cisco IOS Release 12.1(3)T or a later release of Cisco IOS Release 12.1 T Cisco IOS Release 12.2(1) or a later release of Cisco IOS Release 12.2 Cisco IOS Release 12.2(1)T or a later release of Cisco IOS Release 12.2 T Cisco IOS Release 12.2(4)B or a later release of Cisco IOS Release 12.2 B
<ul style="list-style-type: none"> <li>Cisco 7301 routers</li> </ul>	Cisco IOS Release 12.2(11)YZ or a later release of Cisco IOS Release 12.2 YZ
<ul style="list-style-type: none"> <li>Cisco 7401ASR routers</li> </ul>	Cisco IOS Release 12.2(2)DD or a later release of Cisco IOS Release 12.2 DD Cisco IOS Release 12.2(4)B or a later release of Cisco IOS Release 12.2 B
<ul style="list-style-type: none"> <li>Cisco 7500 series routers with VIP<sup>1, 2</sup></li> </ul>	Cisco IOS Release 12.1(3)T or a later release of Cisco IOS Release 12.1 T Cisco IOS Release 12.2(1) or a later release of Cisco IOS Release 12.2 Cisco IOS Release 12.2(1)T or a later release of Cisco IOS Release 12.2 T
<b>PA-VXC-2TE1</b>	
<ul style="list-style-type: none"> <li>Cisco 7200 series and Cisco 7200 VXR routers</li> </ul>	Cisco IOS Release 12.1(3)T or an earlier release of Cisco IOS Release 12.1 T
<ul style="list-style-type: none"> <li>Cisco 7301 routers</li> </ul>	Cisco IOS Release 12.2(11)YZ or a later release of Cisco IOS Release 12.2 YZ
<b>PA-VXC-2TE1+</b>	
<ul style="list-style-type: none"> <li>Cisco 7200 series and Cisco 7200 VXR routers</li> </ul>	Cisco IOS Release 12.1(3)T or a later release of Cisco IOS Release 12.1 T Cisco IOS Release 12.2(1) or a later release of Cisco IOS Release 12.2 Cisco IOS Release 12.2(1)T or a later release of Cisco IOS Release 12.2 T Cisco IOS Release 12.2(4)B or a later release of Cisco IOS Release 12.2 B
<ul style="list-style-type: none"> <li>Cisco 7401ASR routers</li> </ul>	Cisco IOS Release 12.2(2)DD or a later release of Cisco IOS Release 12.2 DD Cisco IOS Release 12.2(4)B or a later release of Cisco IOS Release 12.2 B

Table 2-1 PA-VXA, PA-VXB, and PA-VXC Software and Hardware Requirements (continued)

Port Adapters on Supported Platforms	Recommended Minimum Cisco IOS Release
<ul style="list-style-type: none"> <li>Cisco 7500 series routers with VIP<sup>1, 2</sup></li> </ul>	Cisco IOS Release 12.1(3)T or a later release of Cisco IOS Release 12.1 T Cisco IOS Release 12.2(1) or a later release of Cisco IOS Release 12.2 Cisco IOS Release 12.2(1)T or a later release of Cisco IOS Release 12.2 T

1. The VIP2 and VIP4 support the PA-VXB and PA-VXC.

2. The VIP6 supports the PA-VXA and the PA-VXB.



Note

Voice over Frame Relay is not supported on the Cisco 7500 series router in Cisco IOS Release 12.1(3)T.



Note

The PA-VXB and PA-VXC port adapters are not supported in systems with an NPE-100 installed.

## Checking Hardware and Software Compatibility

To check the minimum software requirements of Cisco IOS software with the hardware installed on your router, Cisco maintains the Software Advisor tool on Cisco.com. This tool does not verify whether modules within a system are compatible, but it does provide the minimum IOS requirements for individual hardware modules or components.



Note

Access to this tool is limited to users with Cisco.com login accounts.

To access Software Advisor, click **Login** at Cisco.com and go to **Technical Support Help—Cisco TAC: Tool Index: Software Advisor**. You can also access the tool by pointing your browser directly to <http://www.cisco.com/cgi-bin/support/CompNav/Index.pl>.

Choose a product family or enter a specific product number to search for the minimum supported software release needed for your hardware.

## Safety Guidelines

This section provides safety guidelines that you should follow when working with any equipment that connects to electrical power or telephone wiring.

## Safety Warnings

Safety warnings appear throughout this publication in procedures that, if performed incorrectly, might harm you. A warning symbol precedes each warning statement.



## Warning

This warning symbol means *danger*. You are in a situation that could cause bodily injury. Before you work on any equipment, be aware of the hazards involved with electrical circuitry and be familiar with standard practices for preventing accidents. To see translations of the warnings that appear in this publication, refer to the *Regulatory Compliance and Safety Information* document that accompanied this device.

## Waarschuwing

Dit waarschuwingssymbool betekent gevaar. U verkeert in een situatie die lichamelijk letsel kan veroorzaken. Voordat u aan enige apparatuur gaat werken, dient u zich bewust te zijn van de bij elektrische schakelingen betrokken risico's en dient u op de hoogte te zijn van standaard maatregelen om ongelukken te voorkomen. Voor vertalingen van de waarschuwingen die in deze publicatie verschijnen, kunt u het document *Regulatory Compliance and Safety Information* (Informatie over naleving van veiligheids- en andere voorschriften) raadplegen dat bij dit toestel is ingesloten.

## Varoitus

Tämä varoitusmerkki merkitsee vaaraa. Olet tilanteessa, joka voi johtaa ruumiinvammaan. Ennen kuin työskentelet minkään laitteiston parissa, ota selvää sähkökytkentöihin liittyvistä vaaroista ja tavanomaisista onnettomuuksien ehkäisykeinoista. Tässä julkaisussa esiintyvien varoitusten käännökset löydät laitteen mukana olevasta *Regulatory Compliance and Safety Information* -kirjasesta (määräysten noudattaminen ja tietoa turvallisuudesta).

## Attention

Ce symbole d'avertissement indique un danger. Vous vous trouvez dans une situation pouvant causer des blessures ou des dommages corporels. Avant de travailler sur un équipement, soyez conscient des dangers posés par les circuits électriques et familiarisez-vous avec les procédures couramment utilisées pour éviter les accidents. Pour prendre connaissance des traductions d'avertissements figurant dans cette publication, consultez le document *Regulatory Compliance and Safety Information* (Conformité aux règlements et consignes de sécurité) qui accompagne cet appareil.

## Warnung

Dieses Warnsymbol bedeutet Gefahr. Sie befinden sich in einer Situation, die zu einer Körperverletzung führen könnte. Bevor Sie mit der Arbeit an irgendeinem Gerät beginnen, seien Sie sich der mit elektrischen Stromkreisen verbundenen Gefahren und der Standardpraktiken zur Vermeidung von Unfällen bewusst. Übersetzungen der in dieser Veröffentlichung enthaltenen Warnhinweise finden Sie im Dokument *Regulatory Compliance and Safety Information* (Informationen zu behördlichen Vorschriften und Sicherheit), das zusammen mit diesem Gerät geliefert wurde.

## Avvertenza

Questo simbolo di avvertenza indica un pericolo. La situazione potrebbe causare infortuni alle persone. Prima di lavorare su qualsiasi apparecchiatura, occorre conoscere i pericoli relativi ai circuiti elettrici ed essere al corrente delle pratiche standard per la prevenzione di incidenti. La traduzione delle avvertenze riportate in questa pubblicazione si trova nel documento *Regulatory Compliance and Safety Information* (Conformità alle norme e informazioni sulla sicurezza) che accompagna questo dispositivo.

## Advarsel

Dette varselsymbolet betyr fare. Du befinner deg i en situasjon som kan føre til personskade. Før du utfører arbeid på utstyr, må du være oppmerksom på de faremomentene som elektriske kretser innebærer, samt gjøre deg kjent med vanlig praksis når det gjelder å unngå ulykker. Hvis du vil se oversettelser av de advarslene som finnes i denne publikasjonen, kan du se i dokumentet *Regulatory Compliance and Safety Information* (Overholdelse av forskrifter og sikkerhetsinformasjon) som ble levert med denne enheten.

<b>Aviso</b>	<b>Este símbolo de aviso indica perigo. Encontra-se numa situação que lhe poderá causar danos físicos. Antes de começar a trabalhar com qualquer equipamento, familiarize-se com os perigos relacionados com circuitos eléctricos, e com quaisquer práticas comuns que possam prevenir possíveis acidentes. Para ver as traduções dos avisos que constam desta publicação, consulte o documento <i>Regulatory Compliance and Safety Information</i> (Informação de Segurança e Disposições Reguladoras) que acompanha este dispositivo.</b>
<b>¡Advertencia!</b>	<b>Este símbolo de aviso significa peligro. Existe riesgo para su integridad física. Antes de manipular cualquier equipo, considerar los riesgos que entraña la corriente eléctrica y familiarizarse con los procedimientos estándar de prevención de accidentes. Para ver una traducción de las advertencias que aparecen en esta publicación, consultar el documento titulado <i>Regulatory Compliance and Safety Information</i> (Información sobre seguridad y conformidad con las disposiciones reglamentarias) que se acompaña con este dispositivo.</b>
<b>Varning!</b>	<b>Denna varningssymbol signalerar fara. Du befinner dig i en situation som kan leda till personskada. Innan du utför arbete på någon utrustning måste du vara medveten om farorna med elkretsar och känna till vanligt förfarande för att förebygga skador. Se förklaringar av de varningar som förkommer i denna publikation i dokumentet <i>Regulatory Compliance and Safety Information</i> (Efterrättelse av föreskrifter och säkerhetsinformation), vilket medföljer denna anordning.</b>

## Electrical Equipment Guidelines

Follow these basic guidelines when working with any electrical equipment:

- Before beginning any procedures requiring access to the chassis interior, locate the emergency power-off switch for the room in which you are working.
- Disconnect all power and external cables before moving a chassis.
- Do not work alone when potentially hazardous conditions exist.
- Never assume that power has been disconnected from a circuit; always check.
- Do not perform any action that creates a potential hazard to people or makes the equipment unsafe; carefully examine your work area for possible hazards such as moist floors, ungrounded power extension cables, and missing safety grounds.

## Telephone Wiring Guidelines

Use the following guidelines when working with any equipment that is connected to telephone wiring or to other network cabling:

- Never install telephone wiring during a lightning storm.
- Never install telephone jacks in wet locations unless the jack is specifically designed for wet locations.
- Never touch uninsulated telephone wires or terminals unless the telephone line has been disconnected at the network interface.
- Use caution when installing or modifying telephone lines.

## Preventing Electrostatic Discharge Damage

Electrostatic discharge (ESD) damage, which can occur when electronic cards or components are improperly handled, results in complete or intermittent failures. Port adapters and processor modules comprise printed circuit boards that are fixed in metal carriers. Electromagnetic interference (EMI) shielding and connectors are integral components of the carrier. Although the metal carrier helps to protect the board from ESD, use a preventive antistatic strap during handling.

Following are guidelines for preventing ESD damage:

- Always use an ESD wrist or ankle strap and ensure that it makes good skin contact.
- Connect the equipment end of the strap to an unfinished chassis surface.
- When installing a component, use any available ejector levers or captive installation screws to properly seat the bus connectors in the backplane or midplane. These devices prevent accidental removal, provide proper grounding for the system, and help to ensure that bus connectors are properly seated.
- When removing a component, use any available ejector levers or captive installation screws to release the bus connectors from the backplane or midplane.
- Handle carriers by available handles or edges only; avoid touching the printed circuit boards or connectors.
- Place a removed board component-side-up on an antistatic surface or in a static shielding container. If you plan to return the component to the factory, immediately place it in a static shielding container.
- Avoid contact between the printed circuit boards and clothing. The wrist strap only protects components from ESD voltages on the body; ESD voltages on clothing can still cause damage.
- Never attempt to remove the printed circuit board from the metal carrier.



### Caution

---

For safety, periodically check the resistance value of the antistatic strap. The measurement should be between 1 and 10 megohms (Mohms).

---

## FCC Class A Compliance

This equipment has been tested and found to comply with the limits for a Class A digital device, pursuant to part 15 of the FCC rules. These limits are designed to provide reasonable protection against harmful interference when the equipment is operated in a commercial environment. This equipment generates, uses, and can radiate radio-frequency energy and, if not installed and used in accordance with the instruction manual, may cause harmful interference to radio communications. Operation of this equipment in a residential area is likely to cause harmful interference, in which case users will be required to correct the interference at their own expense.

You can determine whether your equipment is causing interference by turning it off. If the interference stops, it was probably caused by the Cisco equipment or one of its peripheral devices. If the equipment causes interference to radio or television reception, try to correct the interference by using one or more of the following measures:

- Turn the television or radio antenna until the interference stops.
- Move the equipment to one side or the other of the television or radio.
- Move the equipment farther away from the television or radio.



- Plug the equipment into an outlet that is on a different circuit from the television or radio. (That is, make certain the equipment and the television or radio are on circuits controlled by different circuit breakers or fuses.)

**Note**

---

The PA-VXA, PA-VXB, and PA-VXC port adapters have been designed to meet these requirements. Modifications to this product that are not authorized by Cisco Systems, Inc., could void the various approvals and negate your authority to operate the product.

---





## Removing and Installing Port Adapters

---

This chapter describes how to remove the PA-VXA, PA-VXB, and PA-VXC port adapters from supported platforms and also how to install a new or replacement port adapter. This chapter contains the following sections:

- Handling Port Adapters, page 3-1
- Online Insertion and Removal, page 3-3
- Warnings and Cautions, page 3-4
- Port Adapter Removal and Installation, page 3-9
- Connecting Interface Cables, page 3-15

Each port adapter circuit board is mounted to a metal carrier and is sensitive to electrostatic discharge (ESD) damage.



**Note**

---

When a port adapter slot is not in use, a blank port adapter must fill the empty slot to allow the router or switch to conform to electromagnetic interference (EMI) emissions requirements and to allow proper airflow across the port adapters. If you plan to install a new port adapter in a slot that is not in use, you must first remove the blank port adapter.

---



**Caution**

---

When powering off the router, wait a minimum of 30 seconds before powering it on again.

---

## Handling Port Adapters



**Caution**

---

Always handle the port adapter by the carrier edges and handle; never touch the port adapter components or connector pins. (See Figure 3-1.)

---

Figure 3-1 Handling a Port Adapter

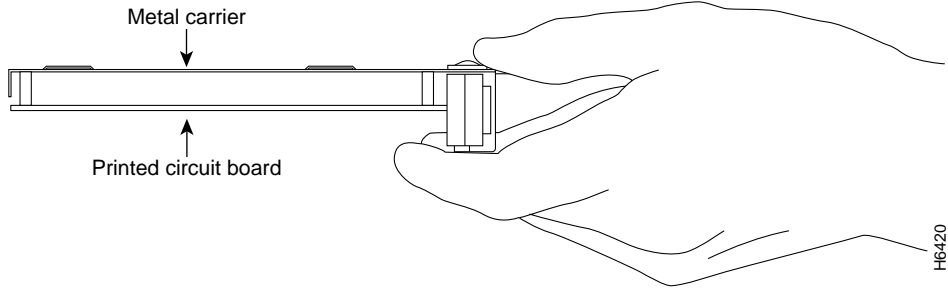

Always handle the VIP by the carrier edges and handle; never touch the VIP components or connector pins. (See Figure 3-2.)

Figure 3-2 Handling the VIP—Horizontal Orientation Shown

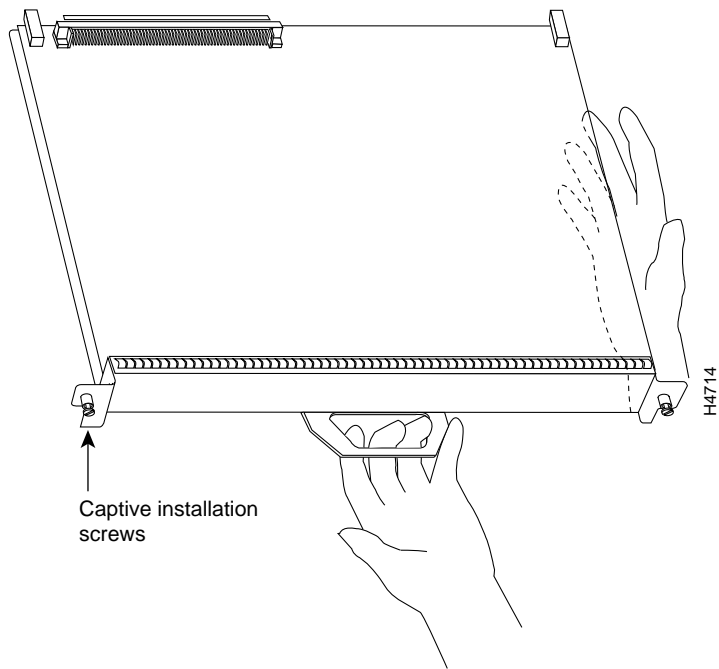

# Online Insertion and Removal

Several platforms support online insertion and removal (OIR) of port adapters; therefore, you do not have to power down routers when removing and replacing a PA-VXA, PA-VXB, or PA-VXC port adapter in Cisco 7200 series routers, Cisco 7200 VXR routers, Cisco 7301 routers, and Cisco 7401ASR routers.

**Note**

---

The Cisco 7301 router is currently supported by the PA-VXB-2TE1+(=) and the PA-VXC-2TE1(=) port adapters only.

---

**Note**

---

The Cisco 7401ASR router is currently supported by the PA-VXB-2TE1+(=) and the PA-VXC-2TE1+(=) port adapters only.

---

Although the Cisco 7500 series routers support online insertion and removal of the VIP motherboard, individual port adapters cannot be inserted or removed from a VIP without first removing it from the chassis. To install a new port adapter in a Cisco 7500 series router, you must first install it on a VIP motherboard.

**Caution**

---

To prevent system problems, do not remove the PA-VXA, PA-VXB, or PA-VXC from the VIP motherboard. To install or replace these port adapters, first remove the VIP from its interface processor slot.

---

It is wise to gracefully shut down the system before removing a port adapter that has active traffic moving through it. Removing a module while traffic is flowing through the ports can cause system disruption. Once the module is inserted, the ports can be brought back up.

**Note**

---

As you disengage the module from the router or switch, online insertion and removal (OIR) administratively shuts down all active interfaces in the module.

---

OIR allows you to install and replace modules while the router is operating; you do not need to notify the software or shut down the system power, although you should not run traffic through the module you are removing while it is being removed. OIR is a method that is seamless to end users on the network, maintains all routing information, and preserves sessions.

The following is a functional description of OIR for background information only; for specific procedures for installing and replacing a module in a supported platform, refer to the “Port Adapter Removal and Installation” section on page 3-9.

Each module has a bus connector that connects it to the router. The connector has a set of tiered pins in three lengths that send specific signals to the system as they make contact with the module. The system assesses the signals it receives and the order in which it receives them to determine if a module is being removed from or introduced to the system. From these signals, the system determines whether to reinitialize a new interface or to shut down a disconnected interface.

Specifically, when you insert a module, the longest pins make contact with the module first, and the shortest pins make contact last. The system recognizes the signals and the sequence in which it receives them.

When you remove or insert a module, the pins send signals to notify the system of changes. The router then performs the following procedure:

1. Rapidly scans the system for configuration changes.
2. Initializes newly inserted port adapters or administratively shuts down any vacant interfaces.
3. Brings all previously configured interfaces on the module back to their previously installed state. Any newly inserted interface is put in the administratively shutdown state, as if it was present (but not configured) at boot time. If a similar module type is reinserted into a slot, its ports are configured and brought online up to the port count of the originally installed module of that type.

**Note**

---

Before you begin installation, read Chapter 2, “Preparing for Installation,” for a list of parts and tools required for installation.

---

## Warnings and Cautions

Observe the following warnings and cautions when installing or removing port adapters.

**Caution**

---

Do not slide a port adapter or VIP motherboard all the way into the slot until you have connected all required cables. Trying to do so disrupts normal operation of the router or switch.

---

**Note**

---

If a port adapter lever or other retaining mechanism does not move to the locked position, the port adapter or VIP motherboard it is installed on is not completely seated in the midplane or backplane. Carefully pull the card halfway out of the slot, reinsert it, and move the port adapter lever or other mechanism to the locked position.

---

## Chassis Warning—Disconnecting Telephone-Network Cables



### Warning

Before opening the chassis, disconnect the telephone-network cables to avoid contact with telephone-network voltages

### Waarschuwing

Voordat u het frame opent, dient u de verbinding met het telefoonnetwerk te verbreken door de kabels te ontkoppelen om zo contact met telefoonnetwerk-spanningen te vermijden.

### Varoitus

Vältä joutumista kosketuksiin puhelinverkostojännitteiden kanssa irrottamalla puhelinverkoston kaapelit ennen asennuspohjan aukaisemista.

### Attention

Avant d'ouvrir le châssis, débrancher les câbles du réseau téléphonique afin d'éviter tout contact avec les tensions d'alimentation du réseau téléphonique.

### Warnung

Bevor Sie das Chassis öffnen, ziehen Sie die Telefonnetzkabel aus der Verbindung, um Kontakt mit Telefonnetzspannungen zu vermeiden.

### Avvertenza

Prima di aprire il telaio, scollegare i cavi della rete telefonica per evitare di entrare in contatto con la tensione di rete.

### Advarsel

Før kabinettet åpnes, skal kablene for telenettet kobles fra for å unngå å komme i kontakt med spenningen i telenettet.

### Aviso

Antes de abrir o chassis, desligue os cabos da rede telefónica para evitar contacto com a tensão da respectiva rede.

### ¡Advertencia!

Antes de abrir el chasis, desconectar el cableado dirigido a la red telefónica para evitar contacto con voltajes de la propia red.

### Varning!

Koppla loss ledningarna till telefontätet innan du öppnar chassit så att kontakten med telefontätsspänningen bryts.

## Lightning Activity Warning



### Warning

Do not work on the system or connect or disconnect cables during periods of lightning activity.

### Waarschuwing

Tijdens onweer dat gepaard gaat met bliksem, dient u niet aan het systeem te werken of kabels aan te sluiten of te ontkoppelen.

### Varoitus

Älä työskentele järjestelmän parissa äläkä yhdistä tai irrota kaapeleita ukkosilmalla.

### Attention

Ne pas travailler sur le système ni brancher ou débrancher les câbles pendant un orage.

Warnung	Arbeiten Sie nicht am System und schließen Sie keine Kabel an bzw. trennen Sie keine ab, wenn es gewittert.
Avvertenza	Non lavorare sul sistema o collegare oppure scollegare i cavi durante un temporale con fulmini.
Advarsel	Utfør aldri arbeid på systemet, eller koble kabler til eller fra systemet når det tordner eller lynner.
Aviso	Não trabalhe no sistema ou ligue e desligue cabos durante períodos de mau tempo (trovoada).
¡Advertencia!	No operar el sistema ni conectar o desconectar cables durante el transcurso de descargas eléctricas en la atmósfera.
Varning!	Vid åska skall du aldrig utföra arbete på systemet eller ansluta eller koppla loss kablar.

## Service Personnel Warning



### Warning

---

This equipment is to be installed and maintained by service personnel only as defined by AS/NZS 3260 Clause 1.2.14.3 Service Personnel.

---

Waarschuwing	Deze apparatuur mag slechts geïnstalleerd en onderhouden worden door servicepersoneel conform de definitie van AS/NZS 3260 Clause 1.2.14.3 Service Personnel.
Varoitus	Tämän laitteen saa asentaa tai huoltaa ainoastaan Australiassa ja Uudessa Seelannissa sovellettavan AS/NZS 3260 -standardin kohdan 1.2.14.3 Service Personnel määrittelemä huoltohenkilöstö.
Attention	Cet équipement ne doit être installé et entretenu que par du personnel d'entretien comme défini par la réglementation AS/NZS 3260 Clause 1.2.14.3 Service Personnel.
Warnung	Dieses Gerät darf nur von Wartungspersonal gemäß AS/NZS-Definition 3260, Paragraph 1.2.14.3, "Service Personnel", installiert und gewartet werden.
Avvertenza	Questo apparecchio deve essere installato e mantenuto in efficienza esclusivamente da personale tecnico che soddisfi i requisiti specificati nella sezione 1.2.14.3 sul 'Service Personnel' contenuta nelle norme AS/NZS 3260.
Advarsel	Installasjon og vedlikehold av dette utstyret skal kun foretas av vedlikeholdspersonell som definert i AS/NZS 3260, klausul 1.2.14.3 Service Personnel.
Aviso	Este equipamento deverá ser instalado e reparado apenas por pessoal de manutenção qualificado, conforme estipulado em AS/NZS 3260 Cláusula 1.2.14.3 Service Personnel.



- ¡Advertencia! Este equipo se debe instalar y mantener solamente por personal de servicio, según definido por AS/NZS 3260 Cláusula 1.2.14.3 Service Personnel.
- Varning! Installation och underhåll av denna utrustning får endast utföras av servicepersonal enligt definition i AS/NZS 3260 klausul 1.2.14.3 Service Personnel.

## No. 26 AWG Warning



Warning

To reduce the risk of fire, use only No. 26 AWG or larger telecommunication line cord.

Waarschuwing

Om brandgevaar te reduceren, dient slechts telecommunicatielijnsnoer nr. 26 AWG of groter gebruikt te worden.

Varoitus

Tulipalovaaran vähentämiseksi käytä ainoastaan nro 26 AWG- tai paksumpaa tietoliikennejohdinta.

Attention

Pour réduire le risque d'incendie, n'utiliser que des cordons de lignes de télécommunications de type AWG n° 26 ou plus larges.

Warnung

Zur Reduzierung der Feuergefahr eine Fernmeldeleitungsschnur der Größe 26 AWG oder größer verwenden.

Avvertenza

Per ridurre il rischio di incendio, usare solo un cavo per linea di telecomunicazioni di sezione 0,12 mm<sup>2</sup> (26 AWG) o maggiore.

Advarsel

Bruk kun AWG nr. 26 eller telekommunikasjonsledninger med større dimensjon for å redusere faren for brann.

Aviso

Para reduzir o risco de incêndio, utilize apenas terminais de fio de telecomunicações N° 26 AWG ou superiores.

¡Advertencia!

Para reducir el riesgo de incendios, usar sólo líneas de telecomunicaciones de calibre No. 26 AWG o más gruesas.

Varning!

För att minska brandrisken skall endast Nr. 26 AWG eller större telekommunikationsledning användas.

## Customer Equipment Warning



### Warning

The E1 interface card may only be installed in an ACA-permitted customer equipment or a Data Terminal Equipment (DTE) that is exempted from ACA's permit requirements. The customer equipment must only be housed in a cabinet that has screw-down lids to stop user access to overvoltages on the customer equipment. The customer equipment has circuitry that may have telecommunications network voltages on them.

### Waarschuwing

De E1-interfacekaart mag slechts geïnstalleerd worden in door ACA toegestane apparatuur van de klant of in Data Terminal Equipment (DTE) die vrijgesteld is van de vergunningsvereisten van ACA. De apparatuur van de klant moet in een kastje geplaatst worden met sluitplaten die dichtgeschroefd kunnen worden om te voorkomen dat de gebruiker toegang verkrijgt tot overspanning op de apparatuur van de klant. De apparatuur van de klant heeft een schakelsysteem waarop telecommunicatienetwerkspanning kan staan.

### Varoitus

E1-liitäntäkortin saa asentaa ainoastaan ACA:n hyväksymiin asiakaslaitteisiin tai Data Terminal Equipment -laitteisiin (DTE), jotka eivät kuulu ACA:n lupavaatimusten piiriin. Asiakaslaitteet on sijoitettava koteloon, jossa on kiinni ruuvattavat kannet, jotta käyttäjä ei altistu asiakaslaitteiden ylijännitteille. Asiakaslaitteissa on virtapiiri, jossa voi olla tietoliikenneverkkojännitteitä.

### Attention

La carte d'interface E1 ne peut être installée que dans un équipement de l'utilisateur autorisé par ACA ou dans un DTE (Data Terminal Equipment) pour lequel l'autorisation de ACA n'est pas exigée. L'équipement de l'utilisateur ne doit être placé que dans une enceinte munie de couvercles à vis qui empêchent l'utilisateur d'accéder aux surtensions présentes. L'équipement de l'utilisateur est muni de circuits qui peuvent avoir des tensions de réseau de télécommunications.

### Warnung

Die E1-Schnittstellenkarte darf nur in einer von der Australian Communications Authority (ACA) zugelassenen Teilnehmereinrichtung oder einer von den ACA-Zulassungsanforderungen ausgenommenen Datenendeinrichtung (DEE) installiert werden. Die Teilnehmereinrichtung muß in einem Gehäuse untergebracht sein, das mit Aufschraubdeckeln versehen ist, um den Zugang der Benutzer zu Überspannungen an der Teilnehmereinrichtung zu verhindern. In der Teilnehmereinrichtung befinden sich Schaltkreise, an denen möglicherweise Fernmeldenetzspannungen anliegen.

### Avvertenza

La scheda d'interfaccia E1 può essere installata solo in un'apparecchiatura con autorizzazione ACA o in un 'Data Terminal Equipment (DTE)' esente dai requisiti per l'autorizzazione ACA. La suddetta apparecchiatura deve essere contenuta in un armadio con coperchi bloccabili con viti, per impedire l'accesso alle sovratensioni in essa presenti; i suoi circuiti possono essere a tensioni di rete di telecomunicazioni.

### Advarsel

Grensesnittkortet E1 kan kun installeres i kundeutstyr som er godkjent av ACA, eller i dataterminalutstyr (DTE) som er unndratt ACAs krav til tillatelse. Kundeutstyret må kun være plassert i et kabinett som har lokk som er skrudd fast, for å hindre brukertilgang til overspenning på kundeutstyret. Kundeutstyret inneholder kretser som kan ha nettverksspenning for telekommunikasjon.

- Aviso** O cartão de ligação E1 apenas poderá ser instalado em equipamento dos clientes que possuam autorização da ACA (Australian Communications Authority) ou num DTE (Data Terminal Equipment), que esteja isento dos requisitos de autorização da ACA. O equipamento dos clientes deverá ser somente colocado numa caixa com tampas de aparafusar, para impossibilitar o acesso do utilizador às altas tensões deste mesmo equipamento. O equipamento do cliente possui circuitos que poderão ter tensões de rede de telecomunicações.
- ¡Advertencia!** La tarjeta de interfaz E1 sólo se puede instalar en un equipo de cliente permitido por ACA o en un equipo de terminal de datos (DTE) que no requiera el permiso de ACA. El equipo del cliente sólo debe estar instalado en un armario con cubiertas atornilladas, para evitar el acceso del usuario a los sobrevoltajes presentes en dicho equipo. El equipo del cliente tiene circuitos donde pueden estar presentes voltajes de la red de telecomunicaciones.
- Varning!** E1-gränssnittskortet får endast installeras i en av ACA tillåten kundutrustning eller en Data Terminal Equipment (DTE) som är undantagen ACA:s licenskrav. Kundutrustningen måste vara i ett skåp med igenskruvade lock som hindrar användaren från att komma åt överspänning på kundutrustningen. Det finns kretsar i kundutrustningen som kan ha nätverksspänning.

**Warning**

---

When performing the following procedures, wear a grounding wrist strap to avoid ESD damage to the card. Some platforms have an ESD connector for attaching the wrist strap. Do not directly touch the midplane or backplane with your hand or any metal tool, or you could shock yourself.

---

**Caution**

---

To prevent jamming the carrier between the upper and the lower edges of the port adapter or interface processor slot, and to ensure that the edge connector at the rear of the port adapter or VIP mates with the connection at the midplane or backplane, make certain that the carrier is positioned correctly, as shown in the cutaway in the following illustrations.

---

## Port Adapter Removal and Installation

In this section, the illustrations that follow give step-by-step instructions on how to remove and install port adapters in the Cisco 7200 series routers, Cisco 7200 VXR routers, Cisco 7401ASR routers, and Cisco 7500 series routers. This section contains the following procedures:

- Cisco 7200 Series—Removing and Installing a Port Adapter, page 3-10
- Cisco 7301 Router—Removing and Installing a Port Adapter, page 3-11
- Cisco 7401ASR Router—Removing and Installing a Port Adapter, page 3-12
- Cisco 7500 Series—Removing and Installing an Interface Processor, page 3-13
- VIP—Removing and Installing a Port Adapter, page 3-14

## Cisco 7200 Series—Removing and Installing a Port Adapter

### Step 1

To remove the port adapter, place the port adapter lever in the unlocked position. (See A.) The port adapter lever remains in the unlocked position.

### Step 2

Grasp the handle of the port adapter and pull the port adapter from the router, about halfway out of its slot. If you are removing a blank port adapter, pull the blank port adapter completely out of the chassis slot.

### Step 3

With the port adapter halfway out of the slot, disconnect all cables from the port adapter. After disconnecting the cables, pull the port adapter from its chassis slot.

### Step 4

To insert the port adapter, carefully align the port adapter carrier between the upper and the lower edges of the port adapter slot. (See B.)

### Step 5

Carefully slide the new port adapter halfway into the port adapter slot. (See B.)

### Step 6

With the port adapter halfway into the slot, connect all required cables to the port adapter. After connecting all required cables, carefully slide the port adapter all the way into the slot until the port adapter is seated in the router midplane.

### Step 7

After the port adapter is properly seated, lock the port adapter lever. (See A.)

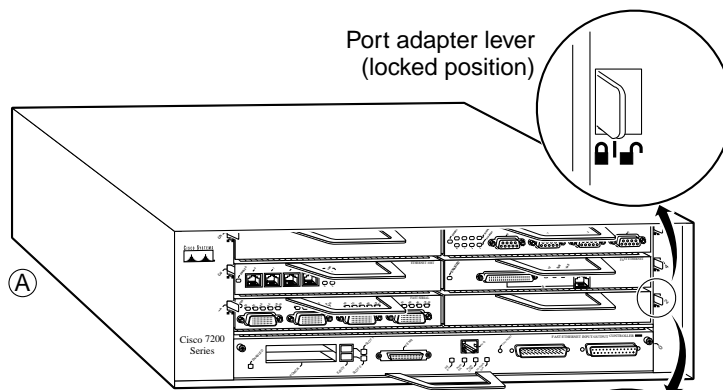

Note: This adapter removal applies to any port or service adapter.

Port adapter lever (unlocked position)

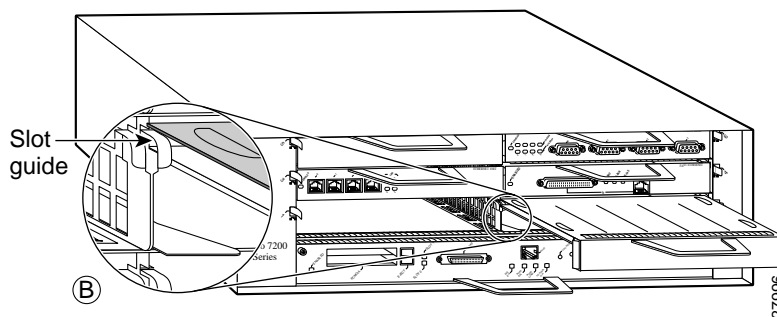

276996

## Cisco 7301 Router—Removing and Installing a Port Adapter

### Step 1

Use an ESD wrist strap to ground yourself to the router.

### Step 2

To remove a port adapter, use a Phillips screwdriver to turn the screw holding the port adapter latch. The screw should be loose enough to allow the latch to rotate to an unlocked position. (See A.) The latch can rotate 360°.

### Step 3

Grasp the handle and pull the port adapter from the router, about halfway out of its slot. (See B.) If you are removing a blank port adapter, pull the blank port adapter completely out of the chassis slot.

### Step 4

With the port adapter halfway out of the slot, disconnect all cables from the port adapter. After disconnecting the cables, pull the port adapter from its chassis slot.

### Caution

The port adapter must slide into the slot guides close to the chassis lid. (See C.) Do not allow the port adapter components to come in contact with the system board or the port adapter could be damaged.

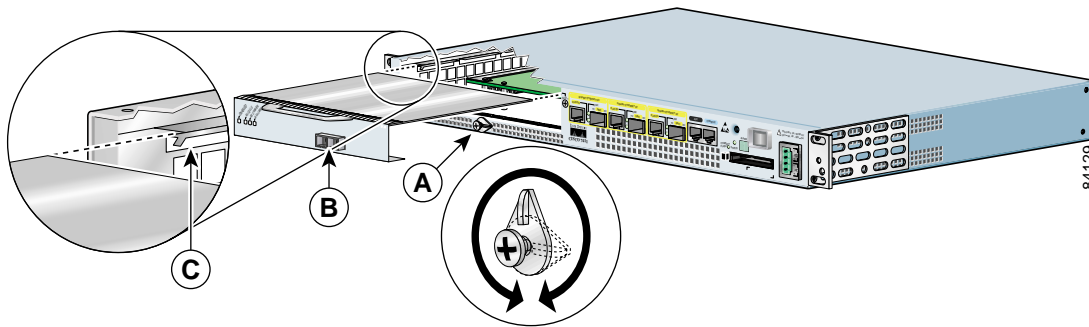

### Step 5

To insert the port adapter, carefully align the port adapter carrier in the slot guides. (See C.) Slide the new port adapter halfway into the chassis.

### Step 6

Connect all required cables to the port adapter. After connecting all required cables, carefully slide the port adapter all the way into the slot until the port adapter is seated in the midplane.

### Step 7

After the port adapter is properly seated, turn and secure the port adapter latch in the upright, locked position. (See A.) Tighten the screw to ensure the port adapter remains firmly in place.

## Cisco 7401ASR Router—Removing and Installing a Port Adapter

### Step 1

To remove the port adapter, use a number 2 Phillips screwdriver to loosen the screw on the port adapter latch. Rotate the port adapter latch until it clears the faceplate of the port adapter. (See A.) The latch can rotate 360°.

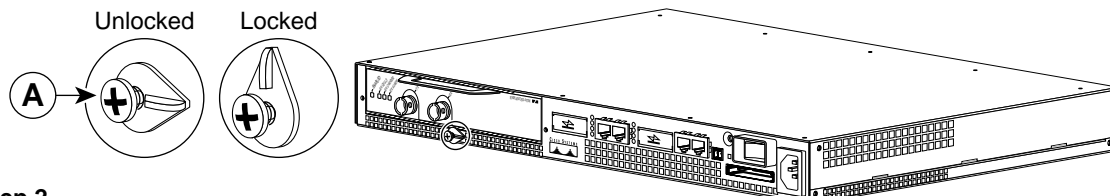

### Step 2

Pull the port adapter from the router, about halfway out of its slot. (If you remove a blank port adapter, keep the blank port adapter for use in the router if you should ever remove the port adapter. The port adapter slot must always be filled.)

### Step 3

With the port adapter halfway out of the slot, disconnect all cables from the port adapter. After disconnecting the cables, pull the port adapter completely out of the chassis slot.

### Step 4

To insert the port adapter, locate the port adapter slot guides inside the Cisco 7401ASR router. They are near the top, and are recessed about 1/2 inch. (See B.)

### Caution

The port adapter must slide into the slot guides under the chassis lid. Do not allow the port adapter components to come in contact with the system board, or the port adapter could be damaged.

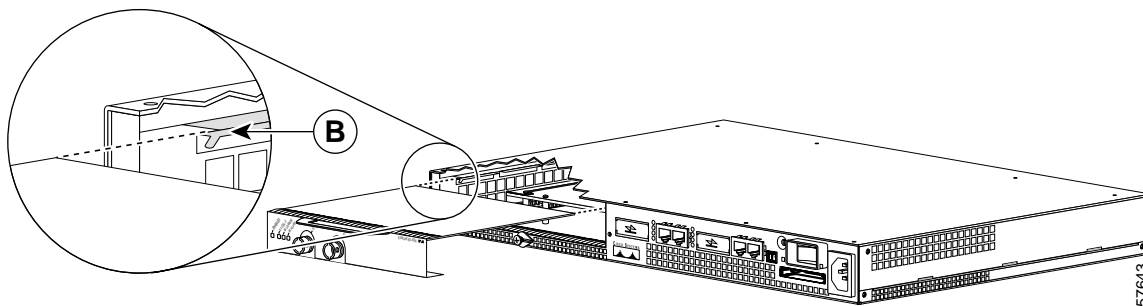

### Step 5

Insert the port adapter in the slot guides halfway, and then reconnect the port adapter cables.

### Step 6

After the cables are connected, carefully slide the port adapter all the way into the slot until the port adapter is seated in the router midplane. When installed, the port adapter input/output panel should be flush with the face of the router.

### Step 7

After the port adapter is properly seated, rotate the port adapter latch to the upright locked position and use a number 2 Phillips screwdriver to tighten the latch. If needed, loosen the latch screw to rotate the latch over the port adapter. Finish the installation by tightening the latch screw.

## Cisco 7500 Series—Removing and Installing an Interface Processor

Remove a module as follows:

1. Use a screwdriver to loosen the captive installation screws (shown in A and D).
2. Simultaneously pull the ejector levers out to release the module from the backplane connector (shown in B). The levers should snap into their spring retainers.
3. Grasp the module handle with one hand and place your other hand under the carrier to support and guide the module as you pull it out of the slot. Avoid touching the card.
4. Place the removed module on an antistatic mat or antistatic foam, or immediately install it in another slot.
5. Install a new module or a filler (MAS7K-BLANK) to keep dust out of the chassis and to maintain proper airflow through the chassis.

Install a module as follows:

1. Choose a slot for the new module and ensure that there is enough clearance to accommodate any interface equipment that you will connect directly to its ports.
2. Use a screwdriver to loosen the captive installation screws (shown in A) and remove the filler (or the existing module) from the slot to be filled.
3. Hold the module handle with one hand, and place your other hand under the carrier to support and guide it into the slot. Avoid touching the card.
4. Place the back of the module in the slot and align the guide on the carrier with the groove in the slot (shown in A).
5. Carefully slide the module into the slot until the faceplate makes contact with the ejector levers (shown in C).
6. Use the thumb and forefinger of each hand to push the ejector lever flat against the module (shown in B).
7. Use a screwdriver to tighten the captive installation screws.

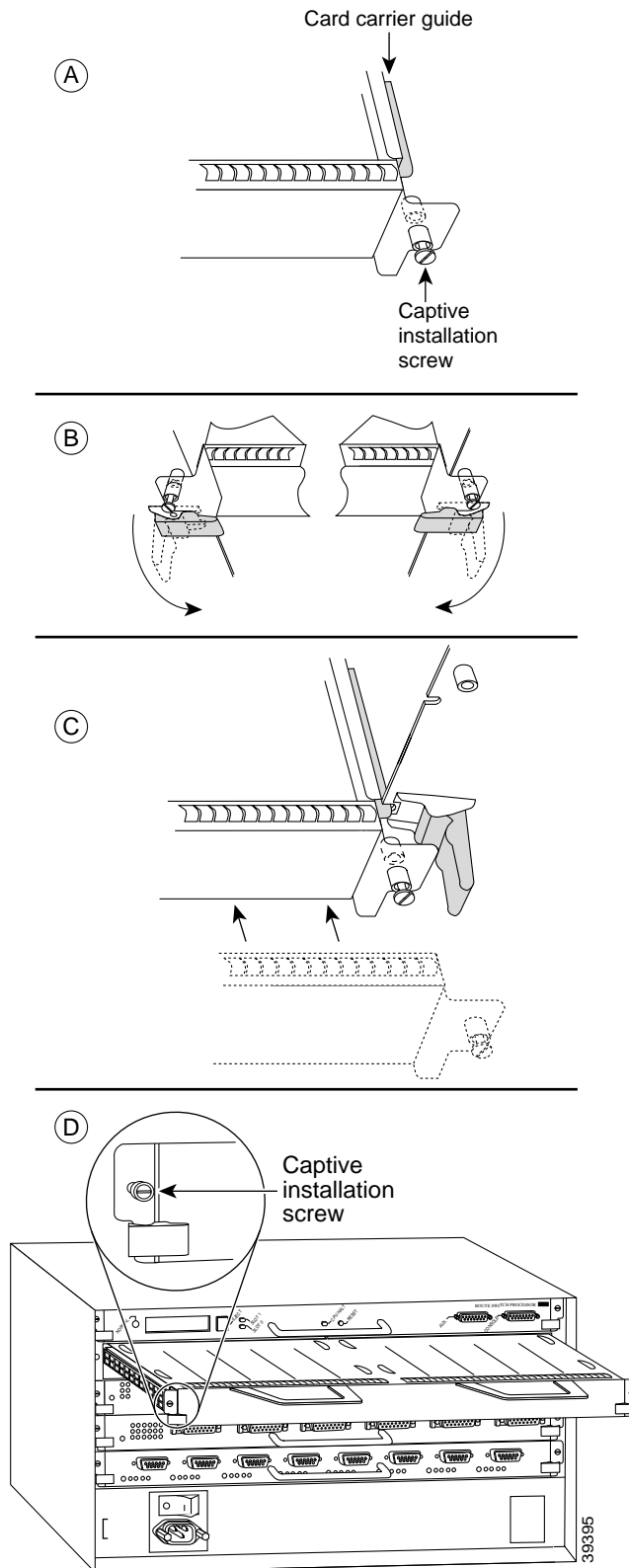

## VIP—Removing and Installing a Port Adapter

Note: You must first remove the VIP from the chassis before removing a port adapter from the VIP.

### Step 1

To remove the port adapter, remove the screw that secures the port adapter (or blank port adapter). (See A.)

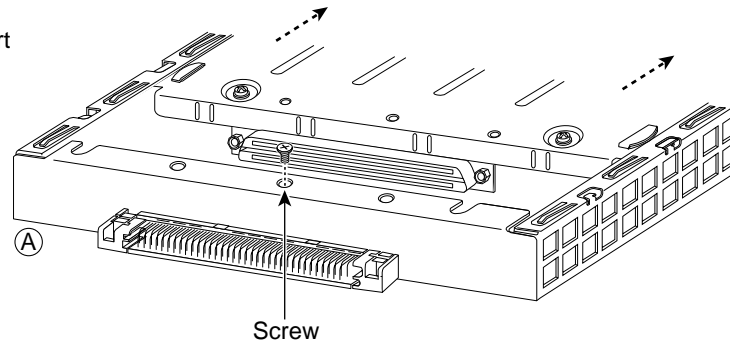

### Step 2

With the screw removed, grasp the handle on the front of the port adapter (or blank port adapter) and carefully pull it out of its slot, away from the edge connector at the rear of the slot. (See A.)

### Step 3

To insert the port adapter, carefully align the port adapter carrier between the upper and the lower edges of the port adapter slot. (See B.)

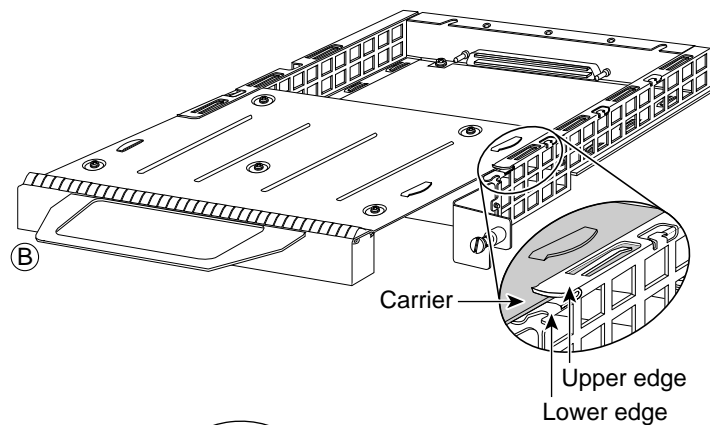

### Step 4

Carefully slide the new port adapter into the port adapter slot until the connector on the port adapter is completely seated in the connector at the rear of the port adapter slot. (See B.)

### Step 5

Install the screw in the rear of the port adapter slot on the VIP. Do not overtighten the screw. (See A.)

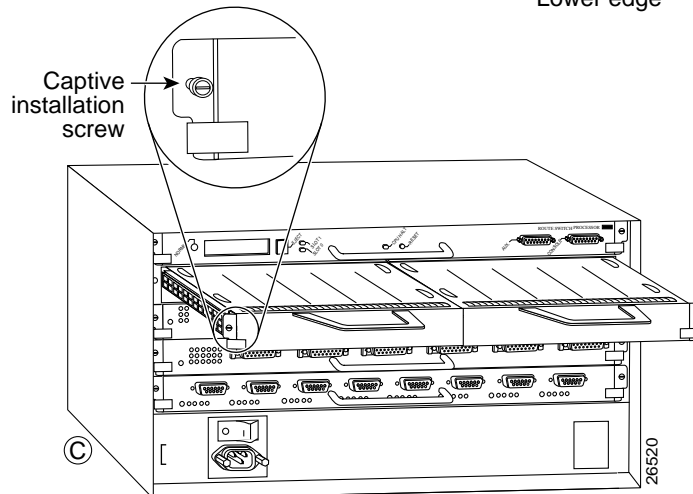

### Step 6

Carefully slide the VIP motherboard into the interface processor slot until the connectors at the rear of the VIP are completely seated in the connectors at the rear of the interface processor slot. Use the ejector levers to seat the VIP in the interface processor slot. Tighten the captive installation screws on the VIP. (See C.)



## Connecting Interface Cables

The PA-VXA, PA-VXB, and PA-VXC port adapters use shielded twisted-pair cables with RJ-45 connectors to connect to a PBX or to the PSTN.

Shielded cables (foil twisted-pair [FTP]) with 120-ohm impedance are required to comply with CE marking requirements. These shielded cables are not available from Cisco Systems; they are available from outside commercial cable vendors.

To connect shielded twisted-pair cables with RJ-45 connectors to the PA-VXA, PA-VXB, or PA-VXC port adapters, proceed as follows:

- 
- Step 1** Attach the cable directly to one of the RJ-45 ports on the PA-VXA, PA-VXB, or PA-VXC port adapter.
  - Step 2** Attach the network end of the cable to your external equipment.
  - Step 3** Repeat Step 1 and Step 2 for the other PA-VXB or PA-VXC port.
- 

**Figure 3-3** Connecting the PA-VXC Twisted-Pair Cable with RJ-45 Connector

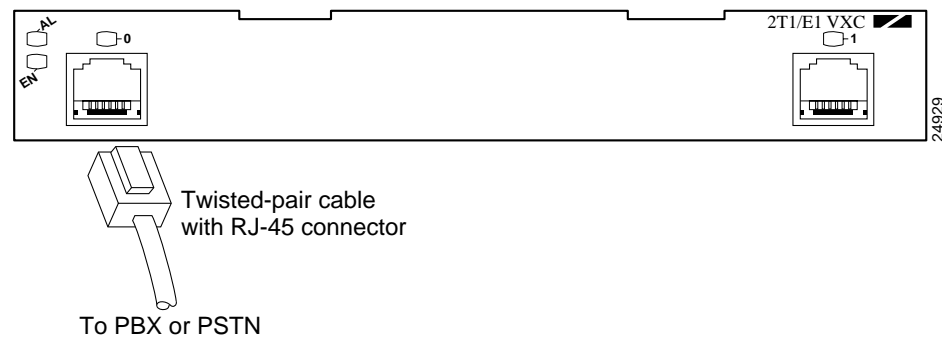

**Note**

Port adapters have a handle attached, but this handle is not shown in Figure 3-3 to allow a full view of the detail on each port adapter faceplate.





## Configuring the PA-VXA, PA-VXB, and PA-VXC

---

To continue your PA-VXA, PA-VXB, or PA-VXC port adapter installation, you must configure the card type as either T1 or E1 and then configure the interfaces. The instructions that follow apply to all supported platforms. Minor differences among the platforms—with Cisco IOS software commands—are noted.

This chapter contains the following sections:

- Using the EXEC Command Interpreter, page 4-1
- Configuring the Interface, page 4-2
- Configuring Voice over IP, page 4-6
- Configuring Voice over Frame Relay, page 4-32
- Checking the Configuration, page 4-34

### Using the EXEC Command Interpreter

You modify the configuration of your router through the software command interpreter called the *EXEC* (also called enable mode). You must enter the privileged level of the EXEC command interpreter with the **enable** command before you can use the **configure** command to configure a new interface or change the existing configuration of an interface. The system prompts you for a password if one has been set.

The system prompt for the privileged level ends with a pound sign (#) instead of an angle bracket (>). At the console terminal, use the following procedure to enter the privileged level:

- 
- Step 1** At the user-level EXEC prompt, enter the **enable** command. The EXEC prompts you for a privileged-level password as follows:

```
Router> enable
```

```
Password:
```

- Step 2** Enter the password (the password is case sensitive). For security purposes, the password is not displayed. When you enter the correct password, the system displays the privileged-level system prompt (#):

```
Router#
```

---

For complete descriptions of software configuration commands, refer to the publications listed in the “Related Documentation” section on page viii.

## Configuring the Interface

After you verify that the new PA-VXA, PA-VXB, or PA-VXC is installed correctly (the enabled LED goes on), use the privileged-level **configure** command to configure the new interface. Have the following information available:

- Protocols you plan to route on the interface
- IP addresses, if you plan to configure the interface for IP routing
- Bridging protocols you plan to use

If you installed a new PA-VXA, PA-VXB, or PA-VXC or if you want to change the configuration of an existing interface, you must enter configuration mode to configure the new interface. If you replaced a PA-VXA, PA-VXB, or PA-VXC that was previously configured, the system recognizes the new interface and brings it up in its existing configuration.

For a summary of the configuration options available and instructions for configuring the interface on a PA-VXA, PA-VXB, or PA-VXC, refer to the appropriate configuration publications listed in the “Related Documentation” section on page viii.

You execute configuration commands from the privileged level of the EXEC command interpreter, which usually requires password access. Contact your system administrator, if necessary, to obtain password access. (See the “Using the EXEC Command Interpreter” section on page 4-1 for an explanation of the privileged level of the EXEC.)

This section contains the following subsections:

- Shutting Down a Controller, page 4-2
- Performing a Basic Configuration, page 4-4

## Shutting Down a Controller

Before you remove a PA-VXA, PA-VXB, or PA-VXC that you will not replace, or replace a PA-VXA, PA-VXB, or PA-VXC, use the **shutdown** command to shut down (disable) the controller to prevent anomalies when you reinstall the new or reconfigured port adapter. When you shut down the controller, it is designated *administratively down* in the **show** command displays.

Follow these steps to shut down an interface:

- 
- Step 1** Enter the privileged level of the EXEC command interpreter (also called enable mode). (See the “Using the EXEC Command Interpreter” section on page 4-1 for instructions.)
- Step 2** At the privileged-level prompt, enter configuration mode and specify that the console terminal is the source of the configuration subcommands, as follows:
- ```
Router# configure terminal
Enter configuration commands, one per line. End with CNTL/Z.
Router(config)#
```
- Step 3** Shut down the controller by entering the **controller t1** or **controller e1** subcommand (followed by the interface address of the controller), and then enter the **shutdown** command. Table 4-1 shows the command syntax.

When you have finished, press **Ctrl-Z**—hold down the **Control** key while you press **Z**—or enter **end** or **exit** to exit configuration mode and return to the EXEC command interpreter.

Table 4-1 Syntax of the shutdown Command

| Platform                                     | Command                                                                                                                                                                                       | Example                                                                                                                                                                                                                       |
|----------------------------------------------|-----------------------------------------------------------------------------------------------------------------------------------------------------------------------------------------------|-------------------------------------------------------------------------------------------------------------------------------------------------------------------------------------------------------------------------------|
| Cisco 7200 series and Cisco 7200 VXR routers | <b>controller</b> , followed by the <i>type</i> ( <b>t1</b> or <b>e1</b> ) and <i>slot/port</i> (port-adapter-slot-number/interface-port-number)                                              | The example is for the T1 controller in port adapter slot 1.<br><br>Router(config)# <b>controller t1 1/0</b><br>Router(config)# <b>shutdown</b><br>Ctrl-Z<br>Router#                                                          |
| Cisco 7301 routers                           | <b>controller</b> , followed by the <i>type</i> ( <b>t1</b> or <b>e1</b> ) and <i>slot/port</i> (port-adapter-slot-number/interface-port-number)                                              | The example is for the T1 controller in port adapter slot 1.<br><br>Router(config)# <b>controller t1 1/0</b><br>Router(config)# <b>shutdown</b><br>Ctrl-Z<br>Router#                                                          |
| Cisco 7401ASR routers                        | <b>controller</b> , followed by the <i>type</i> ( <b>t1</b> or <b>e1</b> ) and <i>slot/port</i> (port-adapter-slot-number/interface-port-number)                                              | The example is for the T1 controller in port adapter slot 1.<br><br>Router(config)# <b>controller t1 1/0</b><br>Router(config)# <b>shutdown</b><br>Ctrl-Z<br>Router#                                                          |
| VIP in Cisco 7500 series routers             | <b>controller</b> , followed by the <i>type</i> ( <b>t1</b> or <b>e1</b> ) and <i>slot/port adapter/port</i> (interface-processor-slot-number/port-adapter-slot-number/interface-port-number) | The example is for the T1 controller in port adapter slot 0 of a VIP installed in interface processor slot 1.<br><br>Router(config-if)# <b>controller t1 1/0/0</b><br>Router(config-if)# <b>shutdown</b><br>Ctrl-Z<br>Router# |

**Step 4** Write the new configuration to NVRAM as follows:

```
Router# copy running-config startup-config
[OK]
Router#
```

The system displays an OK message when the configuration has been stored in NVRAM.

**Step 5** Verify that the new interface is now in the correct state (shut down) using the **show controllers** command (followed by the interface type and interface address of the interface) to display the specific interface.

**Step 6** Reenable the interface by doing the following:

- a. Repeat Step 3 to reenablen an interface. Substitute the **no shutdown** command for the **shutdown** command.
- b. Repeat Step 4 to write the new configuration to memory. Use the **copy running-config startup-config** command.
- c. Repeat Step 5 to verify that the interface is in the correct state. Use the **show controllers** command followed by the type and address of the controller.

For complete descriptions of software configuration commands, refer to the publications listed in the “Related Documentation” section on page viii.

## Performing a Basic Configuration

This section describes guidelines for performing a basic configuration: enabling the PA-VXA, PA-VXB, or PA-VXC port adapter, specifying the card type and controller, and entering various controller subcommands. After configuring the PA-VXA, PA-VXB, or PA-VXC port adapter in a Cisco 7200 series router, Cisco 7200 VXR router, Cisco 7301 router, Cisco 7401ASR router, or Cisco 7500 series router, see the “Configuring Voice over IP” section on page 4-6 for information on configuring your router for VoIP.

### Specifying Card Type is Required

Because the port adapter can be configured for E1 or T1 connectivity, you must specify the card type as E1 or T1, as described in the following procedure. There is no default card type. The port adapter is not functional until the card type is set. Information about the port adapter is not indicated in the output of any show commands unless the card type has been set to E1 or T1.

Before using the **configure** command, you must enter the privileged level of the EXEC command interpreter with the **enable** command. The system prompts you for a password if one has been set.

Use the following procedure to configure the PA-VXA, PA-VXB, or PA-VXC port adapters. Press the **Return** key after each configuration step, unless otherwise noted.

- 
- Step 1** Confirm that the system recognizes the PA-VXA, PA-VXB, or PA-VXC port adapter by entering the **show running-config** command:
- ```
Router# show running-config
```
- Step 2** Use the **configure terminal** command to enter configuration mode and specify that the console terminal is the source of the configuration subcommands:
- ```
Router# configure terminal
```
- Step 3** Specify whether the card is to be used as T1 or E1 by using the **card type** command in configuration mode. The example below sets the card in slot 1 of a Cisco 7200 series router to T1:
- ```
Router(config)# card type t1 1
```
- The example below sets the card in slot 1 of a Cisco 7200 series router to E1:
- ```
Router(config)# card type e1 1
```
- The example below sets the card in port adapter slot 0 on a VIP in interface processor slot 1 of a Cisco 7500 series router to T1:
- ```
Router(config)# card type t1 1 0
```
- The example below sets the card in port adapter slot 0 on a VIP in interface processor slot 1 of a Cisco 7500 series router to E1:
- ```
Router(config)# card type e1 1 0
```



**Note** To change the card type of the PA-VXA, PA-VXB, or PA-VXC after the **card type** command has been entered, you must remove the card from the router, save the running configuration to startup configuration, and reboot the router. When the router has finished rebooting, reinsert the card and repeat Step 3.

- Step 4** Use the **controller** command in configuration mode to enter the controller configuration mode for the desired controller:

```
Router(config)# controller t1
Router(config-controller)#
```



---

**Note** The following steps must be done in controller configuration mode.

---

- Step 5** Use the **framing** command to select carrier framing. If the card is set to T1, set framing to extended super frame (ESF) as shown in the example below:

```
Router(config-controller)# framing esf
```

If the card is set to E1, set framing to CRC4 as shown in the example below:

```
Router(config-controller)# framing crc4
```

- Step 6** Use the **linecode** command to select the line coding. T1 cards should be set to binary 8-zero substitution (B8ZS) as shown in the example below:

```
Router(config-controller)# linecode b8zs
```

E1 cards should be set to HBD3 line code as shown in the example below:

```
Router(config-controller)# linecode hbd3
```

- Step 7** Use the **clock source** command to select between internal or line clocking.

```
Router(config-controller)# clock source line
```



---

**Note** Line clocking is normally selected because of the highly accurate clock source supplied by the network.

---

- Step 8** When installed in a Cisco 7200 VXR router, use the **frame-clock-select** *priority carrier-type controller* command in configuration mode to specify the clock source. This command may be used to specify backup clock sources, as shown in the example below:

```
Router(config)# frame-clock-select 1 T1 1/0
Router(config)# frame-clock-select 2 T1 1/1
```

The example above assigns T1 1/0 as the primary clock source. If that clock fails, T1 1/1 will become the primary clock source.

- Step 9** Use the **ds0-group** *number timeslots range type* command to create a DS0 group.

```
Router(config-controller)# ds0-group 1 timeslots 10-18 type e&m-wink-start
```



---

**Note** The time slot range for a T1 card is 1 to 24, the time slot range for an E1 card is 1 to 30.

---

- Step 10** Change the shutdown state to up and enable the interface:

```
Router(config-controller)# no shutdown
```

---

The **no shutdown** command passes an **enable** command to the PA-VXA, PA-VXB, or PA-VXC port adapter. It also causes the PA-VXA, PA-VXB, or PA-VXC port adapter to configure itself based on the previous configuration commands sent.

## Configuring Voice over IP

Voice Over IP (VoIP) enables a Cisco 7200 series router, Cisco 7200 VXR router, Cisco 7301 router, Cisco 7401ASR router, or Cisco 7500 series router to carry voice traffic (for example, telephone calls and faxes) over an IP network.

VoIP offers the following benefits:

- Toll bypass
- Remote PBX presence over WANs
- Unified voice and data trunking
- POTS-Internet telephony gateways

## Prerequisite Tasks

Before you can configure your Cisco 7200 series router, Cisco 7200 VXR router, Cisco 7301 router, Cisco 7401ASR router, or Cisco 7500 series router to use VoIP, you must first:

- Establish a working IP network. For more information about configuring IP, refer to the “IP Overview” and “IP Addressing and Services” chapters in the *Cisco IOS Release 12.0 Network Protocols Configuration Guide, Part 1*.
- Install the PA-VXA, PA-VXB, or PA-VXC port adapter in your router.
- Complete your company’s dial plan.
- Establish a working telephony network based on your company’s dial plan.
- Integrate your dial plan and telephony network into your existing IP network topology. Merging your IP and telephony networks depends on your particular IP and telephony network topology. In general, we make the following suggestions:
  - Use canonical numbers wherever possible. It is important to avoid situations where numbering systems are significantly different on different routers or access servers in your network.
  - Make routing or dialing transparent to the user—for example, avoid secondary dial tones from secondary switches, where possible.
  - Contact your PBX vendor for instructions about how to reconfigure the appropriate PBX interfaces.

After you have analyzed your dial plan and decided how to integrate it into your existing IP network, you are ready to configure your network devices to support VoIP.



## How VoIP Handles a Typical Telephone Call

Before configuring VoIP on your Cisco 7200 series router, Cisco 7200 VXR router, Cisco 7301 router, Cisco 7401ASR router, or Cisco 7500 series router, it helps to understand what happens at an application level when you place a call using VoIP. The general flow of a two-party voice call using VoIP is as follows:

1. The user picks up the handset; this signals an off-hook condition to the signaling application part of VoIP in the Cisco 7200 series routers, Cisco 7200 VXR routers, Cisco 7301 router, Cisco 7401ASR routers, or Cisco 7500 series routers.
2. The session application part of VoIP issues a dial tone and waits for the user to dial a telephone number.
3. The user dials the telephone number; those numbers are accumulated and stored by the session application.
4. After enough digits are accumulated to match a configured destination pattern, the telephone number is mapped to an IP host through the dial plan mapper. The IP host has a direct connection to either the destination telephone number or a PBX that is responsible for completing the call to the configured destination pattern.
5. The session application then runs the H.323 session protocol to establish a transmission and a reception channel for each direction over the IP network. If the call is being handled by a PBX, the PBX forwards the call to the destination telephone. If Resource Reservation Protocol (RSVP) has been configured, the RSVP reservations are put into effect to achieve the desired quality of service over the IP network.
6. The codecs are enabled for both ends of the connection and the conversation proceeds using Realtime Transport Protocol/User Datagram Protocol/Internet Protocol (RTP/UDP/IP) as the protocol stack.
7. Any call-progress indications (or other signals that can be carried in-band) are cut through the voice path as soon as an end-to-end audio channel is established. Signaling that can be detected by the voice ports (for example, in-band DTMF digits after the call setup is complete) is also trapped by the session application at either end of the connection and carried over the IP network encapsulated in Real Time Conferencing Protocol (RTCP) using the RTCP extension mechanism.
8. When either end of the call hangs up, the RSVP reservations are torn down (if RSVP is used) and the session ends. Each end becomes idle, waiting for the next off-hook condition to trigger another call setup.

## Configuration Tasks

To configure VoIP on the Cisco 7200 series routers, Cisco 7200 VXR routers, Cisco 7301 router, Cisco 7401ASR routers, or Cisco 7500 series routers, you need to perform the following steps:

- Step 1** Configure your IP network to support real-time voice traffic. Fine-tuning your network to adequately support VoIP involves a series of protocols and features geared toward quality of service (QoS). To configure your IP network for real-time voice traffic, you need to take into consideration the entire scope of your network, and then select and configure the appropriate QoS tool or tools:
- RSVP
  - Multilink PPP with interleaving
  - RTP header compression

- Custom queuing
- Weighted fair queuing

See the “Configure IP Networks for Real-Time Voice Traffic” section on page 4-9 for information about how to select and configure the appropriate QoS tools to optimize voice traffic on your network.

- Step 2** (Optional) If you plan to run VoIP over Frame Relay, you need to take certain factors into consideration when configuring VoIP for it to run smoothly over Frame Relay. For example, a public Frame Relay cloud provides no guarantees for QoS. See the “Configuring Voice over Frame Relay” section on page 4-32 for information about deploying VoIP over Frame Relay.
- Step 3** Use the **num-exp** command to configure number expansion if your telephone network is configured so that you can reach a destination by dialing only a portion (an extension number) of the full E.164 telephone number. See the “Configure Number Expansion” section on page 4-14 for information about number expansion.
- Step 4** Use the **dial-peer voice** command to define dial peers and switch to the dial-peer configuration mode. Each dial peer defines the characteristics associated with a call leg. A call leg is a discrete segment of a call connection that lies between two points in the connection. An end-to-end call comprises four call legs, two from the perspective of the source router, and two from the perspective of the destination router. Dial peers are used to apply attributes to call legs and to identify call origin and destination. There are two different kinds of dial peers:
- POTS—Dial peer describing the characteristics of a traditional telephony network connection. POTS peers point to a particular voice port on a voice network device. To minimally configure a POTS dial peer, you need to configure the following two characteristics: associated telephone number and logical interface. Use the **destination-pattern** command to associate a telephone number with a POTS peer. Use the **port** command to associate a specific logical interface with a POTS peer. In addition, you can specify direct inward dialing for a POTS peer by using the **direct-inward-dial** command.
  - VoIP—Dial peer describing the characteristics of a packet network connection; in the case of VoIP, this is an IP network. VoIP peers point to specific VoIP devices. To minimally configure a VoIP peer, you need to configure the following two characteristics: associated destination telephone number and a destination IP address. Use the **destination-pattern** command to define the destination telephone number associated with a VoIP peer. Use the **session-target** command to specify a destination IP address for a VoIP peer.

In addition, you can use VoIP peers to define characteristics such as IP precedence, additional QoS parameters (when RSVP is configured), codec, and voice activation detection (VAD). Use the **ip precedence** command to define IP precedence. If you have configured RSVP, use either the **req-qos** or **acc-qos** command to configure QoS parameters. Use the **codec** command to configure specific voice coder rates. Use the **vad** command to disable voice activation detection and the transmission of silence packets.

See the “Configure Dial Peers” section on page 4-16 and the “Optimize Dial Peer and Network Interface Configurations” section on page 4-29 for additional information about configuring dial peers and dial-peer characteristics.

- Step 5** You need to configure your router to support voice ports. In general, voice-port commands define the characteristics associated with a particular voice-port signaling type. Voice ports on the Cisco 7200 series routers, Cisco 7200 VXR routers, Cisco 7301 router, Cisco 7401ASR routers, and Cisco 7500 series routers support three basic voice signaling types:
- FXO—Foreign Exchange Office interface
  - FXS—Foreign Exchange Station interface
  - E&M—“RecEive and TransMit” interface or the “Ear and Mouth” interface

Under most circumstances, the default voice-port command values are adequate to configure FXO and FXS ports to transport voice data over your existing IP network. Because of the inherent complexities involved with PBX networks, E&M ports might need specific voice-port values configured, depending on the specifications of the devices in your telephony network. For information about configuring voice ports, see the “Configure Voice Ports” section on page 4-22.

## Configure IP Networks for Real-Time Voice Traffic

You need to have a well-engineered end-to-end network when you run delay-sensitive applications such as VoIP. Fine-tuning your network to adequately support VoIP involves a series of protocols and features geared toward quality of service (QoS). It is beyond the scope of this document to explain the specific details relating to wide-scale QoS deployment. Cisco IOS software provides many tools for enabling QoS on your backbone, such as random early detection (RED), weighted random early detection (WRED), fancy queuing (meaning custom, priority, or weighted fair queuing), and IP precedence. To configure your IP network for real-time voice traffic, you must consider the entire scope of your network, and then select the appropriate QoS tool or tools.

The important thing to remember is that QoS must be configured throughout your network—not just on the Cisco 7200 series routers, Cisco 7200 VXR routers, Cisco 7401ASR routers, or Cisco 7500 series routers running VoIP—to improve voice network performance. Not all QoS techniques are appropriate for all network routers. Edge routers and backbone routers in your network do not necessarily perform the same operations; the QoS tasks they perform might differ as well. To configure your IP network for real-time voice traffic, you need to take into consideration the functions of both edge and backbone routers in your network, and then select the appropriate QoS tool or tools.

In general, edge routers perform the following QoS functions:

- Packet classification
- Admission control
- Bandwidth management
- Queuing

In general, backbone routers perform the following QoS functions:

- High-speed switching and transport
- Congestion management
- Queue management

Scalable QoS solutions require cooperative edge and backbone functions.

Although not mandatory, some QoS tools have been identified as valuable in fine-tuning your network to support real-time voice traffic. To configure your IP network for QoS using these tools, perform one or more of the following tasks:

- Configure RSVP for Voice, page 4-10
- Configure Multilink PPP with Interleaving, page 4-11
- Configure RTP Header Compression, page 4-12
- Configure Custom Queuing, page 4-14
- Configure Weighted Fair Queuing, page 4-14

Each of these tasks is discussed in the following sections.

## Configure RSVP for Voice

RSVP allows end systems to request a particular quality of service (QoS) from the network. Real-time voice traffic requires network consistency. Without consistent QoS, real-time traffic can experience jitter, insufficient bandwidth, delay variations, or information loss. RSVP works in conjunction with current queuing mechanisms. It is up to the interface queuing mechanism (such as weighted fair queuing or weighted random early detection) to implement the reservation.

RSVP can be equated to a dynamic access list for packet flows.

You should configure RSVP to ensure QoS if the following conditions exist in your network:

- Small-scale voice network implementation
- Slow links
- Links with high utilization
- Links less than 2 Mbps
- Need for the best possible voice quality

### Enable RSVP

To minimally configure RSVP for voice traffic, you must enable RSVP on each interface where priority needs to be set.

By default, RSVP is disabled so that it is backward compatible with systems that do not implement RSVP. To enable RSVP on an interface, use the following command in interface configuration mode:

```
ip rsvp bandwidth [interface-kbps] [single-flow-kbps]
```

This command starts RSVP and sets the bandwidth and single-flow limits. The default maximum bandwidth is up to 75 percent of the bandwidth available on the interface. By default, the amount reservable by a flow can be up to the entire reservable bandwidth.

On subinterfaces, this command applies the more restrictive of the available bandwidths of the physical interface and the subinterface.

Reservations on individual circuits that do not exceed the single-flow limit normally succeed. If, however, reservations have been made on other circuits adding up to the line speed, and a reservation is made on a subinterface which itself has enough remaining bandwidth, it will still be refused because the physical interface lacks supporting bandwidth.

Cisco 7200 series routers, Cisco 7200 VXR routers, Cisco 7301 router, Cisco 7401ASR routers, and Cisco 7500 series routers running VoIP and configured for RSVP request allocations according to the following formula:

$$\text{bps} = \text{packet\_size} + \text{ip/udp/rtp header size} * 50 \text{ per second}$$

For G.729, the allocation is 24,000 bps. For G.711, the allocation is 80,000 bps.

## RSVP Configuration Example

The following example enables RSVP and sets the maximum bandwidth to 100 kbps and the maximum bandwidth per single request to 32 kbps (the example presumes that both VoIP dial peers have been configured):

```
interface DSPfarm 1/0/0
 ip rsvp bandwidth 100 32
 fair-queue
 end
!
dial-peer voice 1211 voip
 req-qos controlled-load
!
dial-peer voice 1212 voip
 req-qos controlled-load
```

## Configure Multilink PPP with Interleaving

Multiclass Multilink PPP interleaving allows large packets to be multilink-encapsulated and fragmented into smaller packets to satisfy the delay requirements of real-time voice traffic; small real-time packets, which are not multilink-encapsulated, are transmitted between fragments of the large packets. The interleaving feature also provides a special transmit queue for the smaller, delay-sensitive packets, enabling them to be transmitted earlier than other flows. Interleaving provides the delay bounds for delay-sensitive voice packets on a slow link that is used for other best-effort traffic.

**Note**

---

Interleaving applies only to interfaces that can configure a multilink bundle interface. These include virtual templates, dialer interfaces, and Integrated Services Digital Network (ISDN) Basic Rate Interface (BRI) or Primary Rate Interface (PRI).

---

In general, Multilink PPP with interleaving is used in conjunction with weighted fair queuing and RSVP or IP precedence to ensure voice packet delivery. Use Multilink PPP with interleaving and weighted fair queuing to define how data will be managed; use RSVP or IP precedence to give priority to voice packets.

You should configure Multilink PPP if the following conditions exist in your network:

- Point-to-point connection using PPP encapsulation
- Slow links

**Note**

---

Do not use Multilink PPP on links greater than 2 Mbps.

---

## Enable Multilink PPP with Interleaving

Multilink PPP support for interleaving can be configured on virtual templates, dialer interfaces, and ISDN BRI or PRI interfaces. To configure interleaving, you need to complete the following tasks:

- Configure the dialer interface or virtual template, as defined in the relevant chapters of the Cisco IOS Release 12.0 *Dial Solutions Configuration Guide*.
- Configure Multilink PPP and interleaving on the interface or template.

To configure Multilink PPP and interleaving on a configured and operational interface or virtual interface template, use the following commands in interface mode:

|        | Command                                                                                             | Purpose                                                                                                                                                                                                                                       |
|--------|-----------------------------------------------------------------------------------------------------|-----------------------------------------------------------------------------------------------------------------------------------------------------------------------------------------------------------------------------------------------|
| Step 1 | <b>ppp multilink</b>                                                                                | Enable Multilink PPP.                                                                                                                                                                                                                         |
| Step 2 | <b>ppp multilink interleave</b>                                                                     | Enable real-time packet interleaving.                                                                                                                                                                                                         |
| Step 3 | <b>ppp multilink fragment-delay</b><br><i>milliseconds</i>                                          | Optionally, configure a maximum fragment delay.                                                                                                                                                                                               |
| Step 4 | <b>ip rtp reserve</b> <i>lowest-UDP-port</i><br><i>range-of-ports</i><br><i>[maximum-bandwidth]</i> | Reserve a special queue for real-time packet flows to specified destination User Datagram Protocol (UDP) ports, allowing real-time traffic to have higher priority than other flows. This is only applicable if you have not configured RSVP. |



**Note** The **ip rtp reserve** command can be used instead of configuring RSVP. If you configure RSVP, this command is not required.

For more information about Multilink PPP, refer to the “Configuring Media-Independent PPP and Multilink PPP” chapter in the Cisco IOS Release 12.0 *Dial Solutions Configuration Guide*.

### Multilink PPP Configuration Example

The following example defines a virtual interface template that enables Multilink PPP with interleaving and a maximum real-time traffic delay of 20 milliseconds, and then applies that virtual template to the Multilink PPP bundle:

```
interface virtual-template 1
  ppp multilink
  encapsulated ppp
  ppp multilink interleave
  ppp multilink fragment-delay 20
  ip rtp reserve 16384 100 64

multilink virtual-template 1
```

### Configure RTP Header Compression

Real-Time Transport Protocol (RTP) is used for carrying packetized audio traffic over an IP network. RTP header compression compresses the IP/UDP/RTP header in an RTP data packet from 40 bytes to approximately 2 to 4 bytes (most of the time), as shown in Figure 4-1.

This compression feature is beneficial if you are running VoIP over slow links. Enabling compression on both ends of a low-bandwidth serial link can greatly reduce the network overhead if there is a lot of RTP traffic on that slow link.

Typically, an RTP packet has a payload of approximately 20 to 160 bytes for audio applications that use compressed payloads. RTP header compression is especially beneficial when the RTP payload size is small (for example, compressed audio payloads between 20 and 50 bytes).

Figure 4-1 RTP Header Compression

Before RTP header compression:

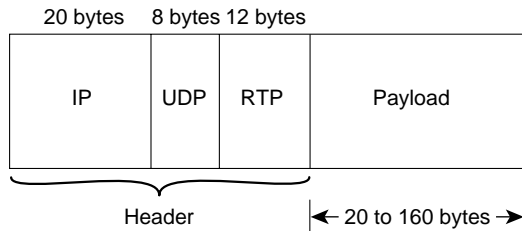

After RTP header compression:

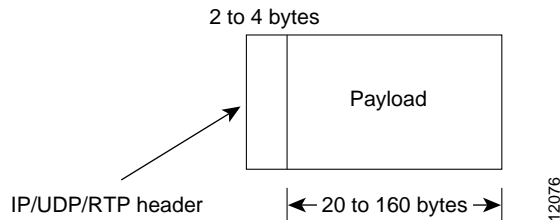

You should configure RTP header compression if the following conditions exist in your network:

- Slow links
- Need to save bandwidth



Note

Do not use RTP header compression on links greater than 2 Mbps.

Perform the following tasks to configure RTP header compression for VoIP. The first task is required; the second task is optional.

- Enable RTP Header Compression on a Serial Interface, page 4-13
- Change the Number of Header Compression Connections, page 4-14

### Enable RTP Header Compression on a Serial Interface

To use RTP header compression, you need to enable compression on both ends of a serial connection. To enable RTP header compression, use the following command in interface configuration mode:

```
ip rtp header-compression [passive]
```

If you include the **passive** keyword, the software compresses outgoing RTP packets only if incoming RTP packets on the same interface are compressed. If you use the command without the **passive** keyword, the software compresses all RTP traffic.

## Change the Number of Header Compression Connections

By default, the software supports a total of 16 RTP header compression connections on an interface. To specify a different number of RTP header compression connections, use the following command in interface configuration mode:

```
ip rtp compression-connections number
```

## RTP Header Compression Configuration Example

The following example enables RTP header compression for a serial interface:

```
interface serial 0
 ip rtp header-compression
 encapsulation ppp
 ip rtp compression-connections 25
```

## Configure Custom Queuing

Some QoS features, such as IP RTP reserve and custom queuing, are based on the transport protocol and the associated port number. Real-time voice traffic is carried on UDP ports ranging from 16384 to 16624. This number is derived from the following formula:

$16384 = 4$  multiplied by the number of voice ports in the Cisco 7200 VXR router

Custom queuing and other methods for identifying high-priority streams should be configured for these port ranges.

## Configure Weighted Fair Queuing

Weighted fair queuing ensures that queues do not starve for bandwidth and that traffic gets predictable service. Low-volume traffic streams receive preferential service; high-volume traffic streams share the remaining capacity, obtaining equal or proportional bandwidth.

In general, weighted fair queuing is used in conjunction with Multilink PPP with interleaving and RSVP or IP precedence to ensure voice packet delivery. Use weighted fair queuing with Multilink PPP to define how data will be managed; use RSVP or IP precedence to give priority to voice packets.

## Configure Number Expansion

In most corporate environments, the telephone network is configured so that you can reach a destination by dialing only a portion (an extension number) of the full E.164 telephone number. VoIP can be configured to recognize extension numbers and expand them into their full E.164 dialed numbers by using two commands in tandem: **destination-pattern** and **num-exp**. Before you configure these two commands, it is helpful to map individual telephone extensions with their full E.164 dialed numbers. This can be done easily by creating a number expansion table.



## Create a Number Expansion Table

In Figure 4-2, a small company wants to use VoIP to integrate its telephony network with its existing IP network. The destination pattern (or expanded telephone number) associated with Router A (located to the left of the IP cloud) is (408) 555-xxxx, where xxxx identifies the individual dial peers by extension. The destination pattern (or expanded telephone number) associated with Router B (located to the right of the IP cloud) is (729) 411-xxxx.

Figure 4-2 Sample VoIP Network

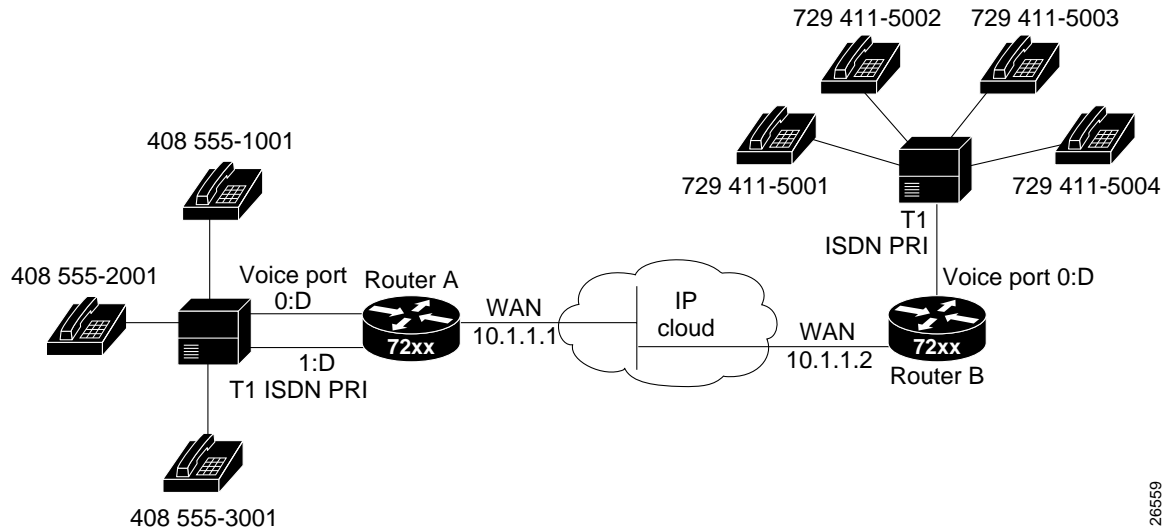

26559

Table 4-2 shows the number expansion table for this scenario.

Table 4-2 Sample Number Expansion Table

| Extension | Destination Pattern | num-exp Command Entry          |
|-----------|---------------------|--------------------------------|
| 1001      | 4085551001          | <b>num-exp 1001 4085551001</b> |
| 2001      | 4085552001          | <b>num-exp 2001 4085552001</b> |
| 3...      | 4085553...          | <b>num-exp 3... 4085553...</b> |
| 5001      | 7294115001          | <b>num-exp 5001 7294115001</b> |
| 5002      | 7294115002          | <b>num-exp 5002 7294115002</b> |
| 5...      | 7294115...          | <b>num-exp 5001 7294115...</b> |



### Note

You can use the period symbol (.) to represent variables (such as extension numbers) in a telephone number.

The information included in this example needs to be configured on both Router A and Router B.

## Expand a Number

To define how to expand an extension number into a particular destination pattern, use the following command in global configuration mode:

```
num-exp extension-number extension-string
```

You can verify the number expansion information by using the **show num-exp** command to verify that you have mapped the telephone numbers correctly.

After you have configured dial peers and assigned destination patterns to them, you can verify number expansion information by using the **show dialplan number** command to see how a telephone number maps to a dial peer.

## Configure Dial Peers

The key point to understanding how VoIP functions is to understand dial peers. Each dial peer defines the characteristics associated with a call leg, as shown in Figure 4-3 and Figure 4-4. A call leg is a discrete segment of a call connection that lies between two points in the connection. All of the call legs for a particular connection have the same connection ID.

There are two different kinds of dial peers:

- POTS—Dial peer describing the characteristics of a traditional telephony network connection. POTS peers point to a particular voice port on a voice network device.
- VoIP—Dial peer describing the characteristics of a packet network connection; in the case of VoIP, this is an IP network. VoIP peers point to specific VoIP devices.

An end-to-end call comprises four call legs, two from the perspective of the source router as shown in Figure 4-3, and two from the perspective of the destination router as shown in Figure 4-4. A dial peer is associated with each one of these call legs. Dial peers are used to apply attributes to call legs and to identify call origin and destination. Attributes applied to a call leg include QoS, codec, VAD, and fax rate.

**Figure 4-3** Dial Peer Call Legs from the Perspective of the Source Router

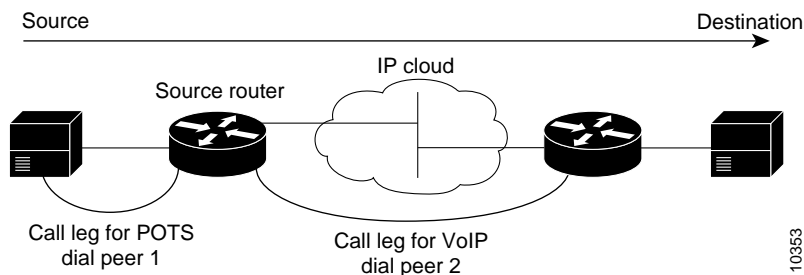
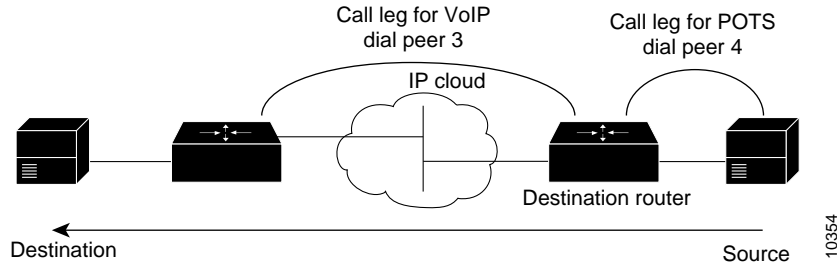

Figure 4-4 Dial Peer Call Legs from the Perspective of the Destination Router



## Inbound Versus Outbound Dial Peers

Dial peers are used for both inbound and outbound call legs. It is important to remember that these terms are defined from the *router's* perspective. An inbound call leg originates *outside* the router. An outbound call leg originates *from* the router.

For inbound call legs, a dial peer might be associated with the calling number or the port designation. Outbound call legs always have a dial peer associated with them. The destination pattern is used to identify the outbound dial peer. The call is associated with the outbound dial peer at setup time.

POTS peers associate a telephone number with a particular voice port so that incoming calls for that telephone number can be received and outgoing calls can be placed. VoIP peers point to specific devices (by associating destination telephone numbers with a specific IP address) so that incoming calls can be received and outgoing calls can be placed. Both POTS and VoIP peers are needed to establish VoIP connections.

Establishing communication using VoIP is similar to configuring an IP static route: you are establishing a specific voice connection between two defined endpoints. As shown in Figure 4-5, for outgoing calls (from the perspective of the POTS dial peer 1), the POTS dial peer establishes the source (through the originating telephone number or voice port) of the call. The VoIP dial peer establishes the destination by associating the destination telephone number with a specific IP address.

Figure 4-5 Outgoing Calls from the Perspective of POTS Dial Peer 1

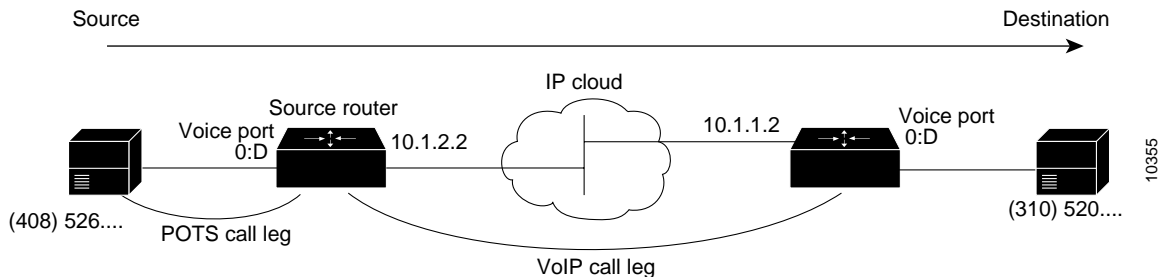

To configure call connectivity between the source and destination as illustrated in Figure 4-5, enter the following commands on router 10.1.2.2:

```
dial-peer voice 1 pots
 destination-pattern 1408526....
 port 1/0/0

dial-peer voice 2 voip
 destination-pattern 1310520....
 session target ipv4:10.1.1.2
```

In the previous configuration example, the last four digits in the VoIP dial peer's destination pattern were replaced with wildcards. This means that from router 10.1.2.2, calling any number string that begins with the digits "1310520" results in a connection to router 10.1.1.2. This implies that router 10.1.1.2 services all numbers beginning with those digits. From router 10.1.1.2, calling any number string that begins with the digits "1408526" will result in a connection to router 10.1.2.2. This implies that router 10.1.2.2 services all numbers beginning with those digits. For more information about stripping and adding digits, see the "Outbound Dialing on POTS Peers" section on page 4-19.

Figure 4-6 shows how to complete the end-to-end call between dial peer 1 and dial peer 4.

Figure 4-6 Outgoing Calls from the Perspective of POTS Dial Peer 2

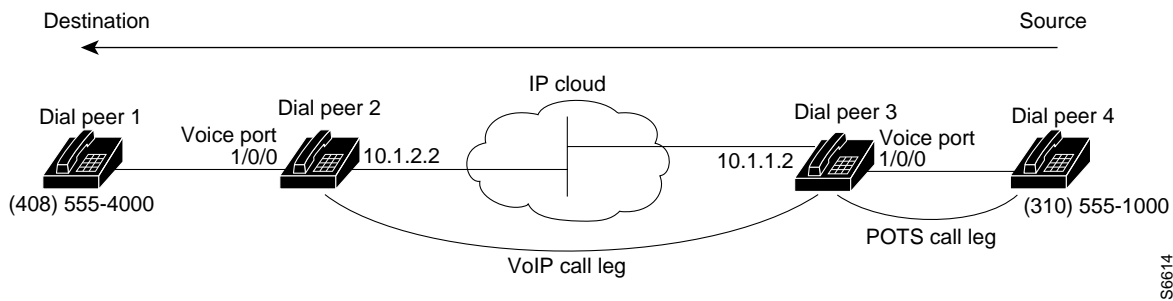

To complete the end-to-end call between dial peer 1 and dial peer 4 as illustrated in Figure 4-6, enter the following commands on router 10.1.1.2:

```
dial-peer voice 4 pots
 destination-pattern 1310555....
 port 1/0/0

dial-peer voice 3 voip
 destination-pattern 1408555....
 session target ipv4:10.1.2.2
```

## Create a Peer Configuration Table

There is specific data relative to each dial peer that needs to be identified before you can configure dial peers in VoIP. One way to do this is to create a peer configuration table.

Using the example in Figure 4-2, Router A, with an IP address of 10.1.1.1, connects a small sales branch office to the main office through Router B. There are three telephones in the sales branch office that need to be established as dial peers. Router B, with an IP address of 10.1.1.2, is the primary gateway to the main office; as such, it needs to be connected to the company's PBX. There are four devices that need to be established as dial peers in the main office, all of which are basic telephones connected to the PBX. Figure 4-2 shows a diagram of this small voice network.

Table 4-3 shows the peer configuration table for the example illustrated in Figure 4-2.

## Configure POTS Peers

**Table 4-3 Peer Configuration Table for Sample VoIP Network**

| Dial Peer Tag   | Ext   | Dest-Pattern | Type | Session-Target | Codec | QoS         |
|-----------------|-------|--------------|------|----------------|-------|-------------|
| <i>Router A</i> |       |              |      |                |       |             |
| 1               | 6.... | +1408555.... | POTS |                |       |             |
| 10              |       | +1729411.... | VoIP | IPV4 10.1.1.2  | G.729 | Best Effort |
| <i>Router B</i> |       |              |      |                |       |             |
| 11              |       | +1408555.... | VoIP | IPV4 10.1.1.1  | G.729 | Best Effort |
| 4               | 2.... | +1729411.... | POTS |                |       |             |

POTS peers enable incoming calls to be received by a particular telephony device. To configure a POTS peer, you need to uniquely identify the peer (by assigning it a unique tag number), define its telephone numbers, and associate it with a voice port through which calls will be established. Under most circumstances, the default values for the remaining dial-peer configuration commands will be sufficient to establish connections.

To enter the dial-peer configuration mode (and select POTS as the method of voice-related encapsulation), use the following command in global configuration mode:

```
dial-peer voice number pots
```

The *number* value of the **dial-peer voice pots** command is a tag that uniquely identifies the dial peer. (This number has local significance only.)

To configure the identified POTS peer, use the following commands in dial-peer configuration mode:

|        | Command                                  | Purpose                                                                      |
|--------|------------------------------------------|------------------------------------------------------------------------------|
| Step 1 | <b>destination-pattern <i>string</i></b> | Define the destination telephone number associated with this POTS dial peer. |
| Step 2 | <b>port controller <i>number</i></b>     | Associate this POTS dial peer with a specific logical dial interface.        |

## Outbound Dialing on POTS Peers

When a router receives a voice call, it selects an outbound dial peer by comparing the called number (the full E.164 telephone number) in the call information with the number configured as the destination pattern for the POTS peer. The router then strips out the left-justified numbers corresponding to the destination pattern matching the called number. If you have configured a prefix, the prefix will be put in front of the remaining numbers, creating a dial string, which the router will then dial. If all numbers in the destination pattern are stripped out, the user receives (depending on the attached equipment) a dial tone.

For example, suppose there is a voice call for which the E.164 called number is 1 (310) 767-2222. If you configure a destination pattern of “1310767” and a prefix of “9,” the router strips out “1310767” from the E.164 telephone number, leaving the extension number of “2222.” It then appends the prefix “9” to the front of the remaining numbers, so that the actual numbers dialed are “9, 2222.” The comma in this example means that the router will pause for one second between dialing the “9” and the “2” to allow for a secondary dial tone.

## Direct Inward Dial for POTS Peers

Direct inward dial (DID) is used to determine how the called number is treated for incoming POTS call legs. As shown in Figure 4-7, incoming means from the perspective of the router. In this case, it is the call leg coming into the router to be forwarded through to the appropriate destination pattern.

Figure 4-7 Incoming and Outgoing POTS Call Legs

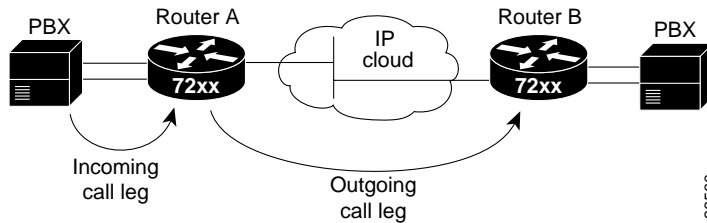

Unless otherwise configured, when a call arrives on the router, the router presents a dial tone to the caller and collects digits until it can identify the destination dial peer. After the dial peer has been identified, the call is forwarded through the next call leg to the destination.

There are cases when it might be necessary for the router to use the called number Dialed Number Identification Service (DNIS) to find a dial peer for the outgoing call leg—for example, if the switch connecting the call to the router has already collected the digits. DID enables the router to match the called number with a dial peer and then directly place the outbound call. With DID, the router does not present a dial tone to the caller and does not collect digits; it forwards the call directly to the configured destination.

To use DID and an incoming called number, a dial peer must be associated with the incoming call leg. It is helpful to understand the logic behind the algorithm used to associate the incoming call leg with the dial peer.

The algorithm used to associate incoming call legs with dial peers uses three inputs (which are derived from signaling and interface information associated with the call) and four defined dial peer elements. The three signaling inputs are:

- Called number (DNIS)—Set of numbers representing the destination, which is derived from the ISDN setup message or CAS DNIS.
- Calling number (ANI)—Set of numbers representing the origin, which is derived from the ISDN setup message or CAS DNIS.
- Voice port—Voice port carrying the call.

The four defined dial peer elements are:

- Destination pattern—Pattern representing the phone numbers to which the peer can connect.
- Answer address—Pattern representing the phone numbers from which the peer can connect.
- Incoming called number—Pattern representing the phone numbers that associate an incoming call leg to a peer based on the called number or DNIS.
- Port—Port through which calls to this peer are placed.

Using the elements, the algorithm is as follows:

- For all peers where call type (VoIP versus POTS) matches dial peer type:
- if the type is matched, associate the called number with the incoming called-number
- else if the type is matched, associate calling-number with answer-address
- else if the type is matched, associate calling-number with destination-pattern
- else if the type is matched, associate voice port to port

This algorithm shows that if a value is not configured for answer address, the origin address is used because, in most cases, the origin address and answer address are the same.

To configure DID for a particular POTS dial peer, use the following commands, initially in global configuration mode:

|        | Command                                          | Purpose                                                          |
|--------|--------------------------------------------------|------------------------------------------------------------------|
| Step 1 | <b>dial-peer voice</b> <i>number</i> <b>pots</b> | Enter the dial-peer configuration mode to configure a POTS peer. |
| Step 2 | <b>direct-inward-dial</b>                        | Specify direct inward dial for this POTS peer.                   |



Note

Direct inward dial is configured for the calling POTS dial peer.

## Configure VoIP Peers

VoIP peers enable outgoing calls to be made from a particular telephony device. To configure a VoIP peer, you need to uniquely identify the peer (by assigning it a unique tag number) and define its destination telephone number and destination IP address. As with POTS peers, under most circumstances, the default values for the remaining dial-peer configuration commands are adequate to establish connections.

To enter the dial-peer configuration mode (and select VoIP as the method of voice-related encapsulation), use the following command in global configuration mode:

**dial-peer voice** *number* **voip**

The *number* value of the **dial-peer voice voip** command is a tag that uniquely identifies the dial peer.

To configure the identified VoIP peer, use the following commands in dial-peer configuration mode:

|        | Command                                                                                                | Purpose                                                                      |
|--------|--------------------------------------------------------------------------------------------------------|------------------------------------------------------------------------------|
| Step 1 | <b>destination-pattern</b> <i>string</i>                                                               | Define the destination telephone number associated with this VoIP dial peer. |
| Step 2 | <b>session-target</b><br>{ <b>ipv4:</b> <i>destination-address</i>  <br><b>dns:</b> <i>host-name</i> } | Specify a destination IP address for this dial peer.                         |

## Verify Configuration

You can check the validity of your dial-peer configuration by performing the following tasks:

- If you have relatively few dial peers configured, you can use the **show dial-peer voice** command to verify that the data configured is correct. Use this command to display a specific dial peer or to display all configured dial peers.
- Use the **show dialplan number** command to show the dial peer to which a particular number (destination pattern) resolves.

## Troubleshooting Tips

If you are having trouble connecting a call and you suspect the problem is associated with dial-peer configuration, you can try to resolve the problem by performing the following tasks:

- Ping the associated IP address to confirm connectivity.
- Use the **show dial-peer voice** command to verify that the operational status of the dial peer is up.
- Use the **show dialplan number** command on the local and remote routers to verify that the data is configured correctly on both.
- If you have configured number expansion, use the **show num-exp** command to check that the partial number on the local router maps to the correct full E.164 telephone number on the remote router.
- If you have configured a codec value, there can be a problem if both VoIP dial peers on either side of the connection have incompatible codec values. Make sure that both VoIP peers have been configured with the same codec value.
- Use the **debug vpm spi** command to verify the output string that the router dials is correct.
- Use the **debug cch323 rtp** command to check RTP packet transport.
- Use the **debug cch323 h225** command to check the call setup.

## Configure Voice Ports

Voice ports on Cisco 7200 series routers, Cisco 7200 VXR routers, Cisco 7301 router, Cisco 7401ASR routers, and Cisco 7500 series routers support three basic voice signaling types:

- FXO—The Foreign Exchange Office interface allows a connection to be directed to the PSTN's central office (or to a standard PBX interface, if the local telecommunications authority permits). This interface is useful for off-premises extension applications.
- FXS—The Foreign Exchange Station interface allows connection for basic telephone equipment, key sets, and PBXs, and supplies ring, voltage, and dial tone.
- E&M—The “Ear and Mouth” interface (or “RecEive and TransMit” interface) allows connection for PBX trunk lines (tie lines). It is a signaling technique for two-wire and four-wire telephone and trunk interfaces.

In general, voice-port commands define the characteristics associated with a particular voice-port signaling type. Under most circumstances, the default voice-port command values are adequate to configure FXO and FXS ports to transport voice data over your existing IP network. Because of the inherent complexities involved with PBX networks, E&M ports might need specific voice-port values configured, depending on the specifications of the devices in your telephony network.



## Configure FXO or FXS Voice Ports

Under most circumstances, the default voice-port values are adequate for both FXO and FXS voice ports. If you need to change the default configuration for these voice ports, perform the following tasks. Items included in Step 1 and Step 2 are required; items included in Step 3 are optional.

- 
- Step 1** Identify the voice port and enter the voice-port configuration mode by using the **voice-port** command.
- Step 2** Configure the following mandatory voice-port parameters by using the indicated commands:
- Dial type (FXO only) using the **dial-type** command
  - Signal type using the **signal** command
  - Call progress tone using the **cptone** command
  - Ring frequency (FXS only) using the **ring frequency** command
  - Ring number (FXO only) using the **ring number** command
- Step 3** Configure one or more of the following optional voice-port parameters by using the indicated commands:
- PLAR connection mode using the **connection plar** command
  - Music threshold using the **music-threshold** command
  - Description using the **description** command
  - Comfort noise (if VAD is activated—**vad** is a dial-peer command) using the **comfort-noise** command
- 

To configure FXO and FXS voice ports, use the following commands beginning in privileged EXEC mode:

|        | Command                                                     | Purpose                                                                                                                                                                                                                        |
|--------|-------------------------------------------------------------|--------------------------------------------------------------------------------------------------------------------------------------------------------------------------------------------------------------------------------|
| Step 1 | <b>configure terminal</b>                                   | Enter the global configuration mode.                                                                                                                                                                                           |
| Step 2 | <b>voice-port</b><br><i>slot-number/subunit-number/port</i> | Identify the voice port you want to configure and enter the voice-port configuration mode.                                                                                                                                     |
| Step 3 | <b>dial-type</b> { <b>dtmf</b>   <b>pulse</b> }             | (For FXO ports only.) Select the appropriate dial type for out-dialing.                                                                                                                                                        |
| Step 4 | <b>signal</b> { <b>loop-start</b>   <b>ground-start</b> }   | Select the appropriate signal type for this interface.                                                                                                                                                                         |
| Step 5 | <b>cptone</b> <i>country</i>                                | Select the appropriate voice call progress tone for this interface. The default for this command is <b>us</b> . For a list of supported countries, refer to the <i>Voice, Video, and Home Applications Command Reference</i> . |
| Step 6 | <b>ring number</b> <i>number</i>                            | (For FXO ports only.) Specify the maximum number of rings to be detected before answering a call.                                                                                                                              |
| Step 7 | <b>connection plar</b> <i>string</i>                        | (Optional.) Specify the Private Line Auto Ringdown (PLAR) connection if this voice port is used for a PLAR connection. The <i>string</i> value specifies the destination telephone number.                                     |

|         | Command                              | Purpose                                                                                                     |
|---------|--------------------------------------|-------------------------------------------------------------------------------------------------------------|
| Step 8  | <b>music-threshold</b> <i>number</i> | (Optional.) Specify the threshold (in decibels) for on-hold music. Valid entries are from –70 dB to –30 dB. |
| Step 9  | <b>description</b> <i>string</i>     | (Optional.) Attach descriptive text about this voice-port connection.                                       |
| Step 10 | <b>comfort-noise</b>                 | (Optional.) Specify that background noise will be generated.                                                |

## Validation Tips

You can check the validity of your voice-port configuration by performing the following tasks:

- Pick up the handset of an attached telephony device and check for a dial tone.
- If you have dial tone, check for dual tone multifrequency (DTMF) detection. If the dial tone stops when you dial a digit, then the voice port is most likely configured properly.
- Use the **show voice-port** command to verify that the data configured is correct.

## Troubleshooting Tips

If you are having trouble connecting a call and you suspect the problem is associated with voice-port configuration, you can try to resolve the problem by performing the following tasks:

- Ping the associated IP address to confirm connectivity.
- Use the **show voice-port** command to make sure that the port is enabled. If the port is offline, use the **no shutdown** command.
- If you have configured E&M interfaces, make sure that the values pertaining to your specific PBX setup, such as timing or type, are correct.
- Check to see if the voice network module has been correctly installed. For more information, refer to the installation document *Voice Network Module and Voice Interface Card Configuration Note* that came with your voice network module.

## Fine-Tune FXO and FXS Voice Ports

Depending on the specifics of your particular network, you might need to adjust voice parameters involving timing, input gain, and output attenuation for FXO or FXS voice ports. Collectively, these commands are referred to as voice-port tuning commands.



### Note

In most cases, the default values for voice-port tuning commands are sufficient.

To configure voice-port tuning for FXO and FXS voice ports, perform the following steps:

- Step 1 Identify the voice port and enter the voice-port configuration mode using the **voice-port** command.
- Step 2 For each of the following parameters, select the appropriate value using the commands indicated:
  - Input gain using the **input gain** command
  - Output attenuation using the **output attenuation** command
  - Echo cancel coverage using the **echo-cancel enable** and **echo-cancel coverage** commands

- Nonlinear processing using the **non-linear** command
- Initial digit timeouts using the **timeouts initial** command
- Interdigit timeouts using the **timeouts interdigits** command
- Timing other than timeouts using the **timing digit**, **timing inter-digit**, **timing pulse-digit**, and **timing pulse-inter-digit** commands

To fine-tune FXO or FXS voice ports, use the following commands beginning in privileged EXEC mode:

|         | Command                                                     | Purpose                                                                                                                                                                                              |
|---------|-------------------------------------------------------------|------------------------------------------------------------------------------------------------------------------------------------------------------------------------------------------------------|
| Step 1  | <b>configure terminal</b>                                   | Enter the global configuration mode.                                                                                                                                                                 |
| Step 2  | <b>voice-port</b><br><i>slot-number/subunit-number/port</i> | Identify the voice port you want to configure and enter the voice-port configuration mode.                                                                                                           |
| Step 3  | <b>echo-cancel enable</b>                                   | Enable echo cancellation of voice that is sent out the interface and received back on the same interface.                                                                                            |
| Step 4  | <b>echo-cancel coverage</b> <i>value</i>                    | Adjust the size (in milliseconds) of the echo cancel. Acceptable values are 16, 24, and 32.                                                                                                          |
| Step 5  | <b>non-linear</b>                                           | Enable nonlinear processing, which shuts off any signal if no near-end speech is detected. (Nonlinear processing is used with echo cancellation.)                                                    |
| Step 6  | <b>timeouts initial</b> <i>seconds</i>                      | Specify the number of seconds the system waits for the caller to input the first digit of the dialed digits. Valid entries for this command are from 0 to 120.                                       |
| Step 7  | <b>timeouts interdigit</b> <i>seconds</i>                   | Specify the number of seconds the system waits (after the caller has input the initial digit) for the caller to input a subsequent digit. Valid entries for this command are from 0 to 120.          |
| Step 8  | <b>timing digit</b> <i>milliseconds</i>                     | If the voice-port dial type is DTMF, configure the DTMF digit signal duration. The range of the DTMF digit signal duration is from 50 to 100. The default is 100.                                    |
| Step 9  | <b>timing inter-digit</b> <i>milliseconds</i>               | If the voice-port dial type is DTMF, configure the DTMF inter-digit signal duration. The range of the DTMF inter-digit signal duration is from 50 to 500. The default is 100.                        |
| Step 10 | <b>timing pulse-digit</b> <i>milliseconds</i>               | (FXO ports only.) If the voice-port dial type is pulse, configure the pulse-digit signal duration. The range of the pulse-digit signal duration is from 10 to 20. The default is 20.                 |
| Step 11 | <b>timing pulse-inter-digit</b><br><i>milliseconds</i>      | (FXO ports only.) If the voice-port dial type is pulse, configure the pulse inter-digit signal duration. The range of the pulse-inter-digit signal duration is from 100 to 1000. The default is 500. |

**Note**

After you change any voice-port command, it is a good idea to cycle the port by using the **shutdown** and **no shutdown** commands.

## Configure E&M Voice Ports

Unlike FXO and FXS voice ports, the default E&M voice-port parameters most likely are not sufficient to enable voice data transmission over your IP network. E&M voice-port values must match those specified by the particular PBX device to which the voice port is connected.

To configure an E&M voice port, perform the following steps. Items included in Step 1 and Step 2 are required; items included in Step 3 are optional.

- 
- Step 1** Identify the voice port and enter the voice-port configuration mode by using the **voice-port** command.
- Step 2** For each of the following required parameters, select the appropriate parameter value by using the commands indicated:
- Dial type using the **dial-type** command
  - Signal type using the **signal** command
  - Call progress tone using the **cptone** command
  - Operation using the **operation** command
  - Type using the **type** command
  - Impedance using the **impedance** command
- Step 3** Select one or more of the following optional parameters by using the indicated commands:
- PLAR connection mode using the **connection plar** command
  - Music threshold using the **music-threshold** command
  - Description using the **description** command
  - Comfort tone (if VAD is activated) using the **comfort-noise** command
- 

To configure E&M voice ports, use the following commands beginning in privileged EXEC mode:

|        | Command                                                                                                                                                                         | Purpose                                                                                    |
|--------|---------------------------------------------------------------------------------------------------------------------------------------------------------------------------------|--------------------------------------------------------------------------------------------|
| Step 1 | <b>configure terminal</b>                                                                                                                                                       | Enter the global configuration mode.                                                       |
| Step 2 | <b>voice-port</b><br><i>slot-number/subunit-number/port</i>                                                                                                                     | Identify the voice port you want to configure and enter the voice-port configuration mode. |
| Step 3 | <b>dial-type</b> { <b>dtmf</b>   <b>pulse</b> }                                                                                                                                 | Select the appropriate dial type for out-dialing.                                          |
| Step 4 | <b>signal</b> { <b>wink-start</b>   <b>immediate</b>   <b>delay-dial</b> }                                                                                                      | Select the appropriate signal type for this interface.                                     |
| Step 5 | <b>cptone</b> { <b>australia</b>   <b>brazil</b>   <b>china</b>   <b>finland</b>   <b>france</b>   <b>germany</b>   <b>japan</b>   <b>northamerica</b>   <b>unitedkingdom</b> } | Select the appropriate voice call progress tone for this interface.                        |

|        | Command                              | Purpose                                                                                                                                                                                    |
|--------|--------------------------------------|--------------------------------------------------------------------------------------------------------------------------------------------------------------------------------------------|
| Step 6 | <b>connection plar</b> <i>string</i> | (Optional.) Specify the Private Line Auto Ringdown (PLAR) connection if this voice port is used for a PLAR connection. The <i>string</i> value specifies the destination telephone number. |
| Step 7 | <b>music-threshold</b> <i>number</i> | (Optional.) Specify the threshold (in decibels) for on-hold music. Valid entries are from -70 dB to -30 dB.                                                                                |
| Step 8 | <b>description</b> <i>string</i>     | (Optional.) Attach descriptive text about this voice-port connection.                                                                                                                      |
| Step 9 | <b>comfort-noise</b>                 | (Optional.) Specify that background noise will be generated.                                                                                                                               |

## Validation Tips

You can check the validity of your voice-port configuration by performing the following tasks:

- Pick up the handset of an attached telephony device and check for a dial tone.
- If you have a dial tone, check for DTMF detection. If the dial tone stops when you dial a digit, then the voice port is most likely configured properly.
- Use the **show voice-port** command to verify that the data configured is correct.

## Troubleshooting Tips

If you are having trouble connecting a call and you suspect the problem is associated with voice-port configuration, you can try to resolve the problem by performing the following tasks:

- Ping the associated IP address to confirm connectivity. If you cannot successfully ping your destination, refer to the *Network Protocols Configuration Guide, Part 1*.
- Use the **show voice-port** command to make sure that the port is enabled. If the port is offline, use the **no shutdown** command.
- If you have configured E&M interfaces, make sure that the values pertaining to your specific PBX setup, such as timing or type, are correct.
- Check to see if the voice network module has been correctly installed. For more information, refer to the installation document that came with your voice network module.

## Fine-Tune E&M Voice Ports

Depending on the specifics of your particular network, you may need to adjust voice parameters involving timing, input gain, and output attenuation for E&M voice ports. Collectively, these commands are referred to as voice-port tuning commands.



Note

In most cases, the default values for voice-port tuning commands are sufficient.

To configure voice-port tuning for E&M voice ports, perform the following steps:

- 
- Step 1** Identify the voice port and enter the voice-port configuration mode by using the **voice-port** command.
- Step 2** For each of the following parameters, select the appropriate value using the commands indicated:
- Input gain using the **input gain** command
  - Output attenuation using the **output attenuation** command
  - Echo cancel coverage using the **echo-cancel enable** and **echo-cancel coverage** commands
  - Nonlinear processing using the **non-linear** command
  - Initial digit timeouts using the **timeouts initial** command
  - Interdigit timeouts using the **timeouts interdigit** command
  - Timing other than timeouts using the **timing clear-wait**, **timing delay-duration**, **timing delay-start**, **timing dial-pulse min-delay**, **timing digit**, **timing inter-digit**, **timing pulse**, **timing pulse-inter-digit**, **timing wink-duration**, and **timing wink-wait** commands
- 

To fine-tune E&M voice ports, use the following commands beginning in privileged EXEC mode:

|        | Command                                                     | Purpose                                                                                                                                                        |
|--------|-------------------------------------------------------------|----------------------------------------------------------------------------------------------------------------------------------------------------------------|
| Step 1 | <b>configure terminal</b>                                   | Enter the global configuration mode.                                                                                                                           |
| Step 2 | <b>voice-port</b><br><i>slot-number/subunit-number/port</i> | Identify the voice port you want to configure and enter the voice-port configuration mode.                                                                     |
| Step 3 | <b>echo-cancel enable</b>                                   | Enable echo cancellation of voice that is sent out the interface and received back on the same interface.                                                      |
| Step 4 | <b>echo-cancel coverage</b> <i>value</i>                    | Adjust the size (in milliseconds) of the echo cancel. Acceptable values are 16, 24, and 32.                                                                    |
| Step 5 | <b>non-linear</b>                                           | Enable nonlinear processing, which shuts off any signal if no near-end speech is detected. (Nonlinear processing is used with echo cancellation.)              |
| Step 6 | <b>timeouts initial</b> <i>seconds</i>                      | Specify the number of seconds the system waits for the caller to input the first digit of the dialed digits. Valid entries for this command are from 0 to 120. |

|        | Command                                                                                                                                                                                                                                                                                                                                                                                                                                                                                                         | Purpose                                                                                                                                                                                                                                                                                                                                                                                                                                                                                                                                                                                                                                                                                  |
|--------|-----------------------------------------------------------------------------------------------------------------------------------------------------------------------------------------------------------------------------------------------------------------------------------------------------------------------------------------------------------------------------------------------------------------------------------------------------------------------------------------------------------------|------------------------------------------------------------------------------------------------------------------------------------------------------------------------------------------------------------------------------------------------------------------------------------------------------------------------------------------------------------------------------------------------------------------------------------------------------------------------------------------------------------------------------------------------------------------------------------------------------------------------------------------------------------------------------------------|
| Step 7 | <b>timeouts interdigit</b> <i>seconds</i>                                                                                                                                                                                                                                                                                                                                                                                                                                                                       | Specify the number of seconds the system waits (after the caller has input the initial digit) for the caller to input a subsequent digit. Valid entries for this command are from 0 to 120.                                                                                                                                                                                                                                                                                                                                                                                                                                                                                              |
| Step 8 | <b>timing clear-wait</b> <i>milliseconds</i><br><b>timing delay-duration</b> <i>milliseconds</i><br><b>timing delay-start</b> <i>milliseconds</i><br><b>timing dial-pulse min-delay</b> <i>milliseconds</i><br><b>timing digit</b> <i>milliseconds</i><br><b>timing inter-digit</b> <i>milliseconds</i><br><b>timing pulse</b> <i>pulse-per-second</i><br><b>timing pulse-inter-digit</b> <i>milliseconds</i><br><b>timing wink-duration</b> <i>milliseconds</i><br><b>timing wink-wait</b> <i>milliseconds</i> | Specify timing parameters. Valid entries for <b>clear-wait</b> are from 200 to 2000 milliseconds (ms). Valid entries for <b>delay-duration</b> are from 100 to 5000 ms. Valid entries for <b>delay-start</b> are from 20 to 2000 ms. Valid entries for <b>dial-pulse min-delay</b> are from 0 to 5000 ms. Valid entries for <b>digit</b> are from 50 to 100 ms. Valid entries for <b>inter-digit</b> are from 50 to 500 ms. Valid entries for <b>pulse</b> are from 10 to 20 pulse-per-second. Valid entries for <b>pulse-inter-digit</b> are 100 to 1000 ms. Valid entries for <b>wink-duration</b> are from 100 to 400 ms. Valid entries for <b>wink-wait</b> are from 100 to 5000 ms. |

**Note**

After you change any voice-port command, it is a good idea to cycle the port by using the **shutdown** and **no shutdown** commands.

## Optimize Dial Peer and Network Interface Configurations

Depending on how you have configured your network interfaces, you might need to configure additional VoIP dial-peer parameters. This section describes the following topics:

- Configure IP Precedence for Dial Peers, page 4-29
- Configure RSVP for Dial Peers, page 4-30
- Configure Codec and VAD for Dial Peers, page 4-31

### Configure IP Precedence for Dial Peers

If you want to give real-time voice traffic a higher priority than other network traffic, you can weight the voice data traffic associated with a particular VoIP dial peer by using IP precedence. IP precedence scales better than RSVP but provides no admission control.

To give real-time voice traffic precedence over other IP network traffic, use the following commands, beginning in global configuration mode:

|        | Command                                          | Purpose                                                                         |
|--------|--------------------------------------------------|---------------------------------------------------------------------------------|
| Step 1 | <b>dial-peer voice</b> <i>number</i> <b>voip</b> | Enter the dial-peer configuration mode to configure a VoIP peer.                |
| Step 2 | <b>ip precedence</b> <i>number</i>               | Select a precedence level for the voice traffic associated with that dial peer. |

In IP precedence, the numbers 1 through 5 identify classes for IP flows; the numbers 6 and 7 are used for network and backbone routing and updates.

For example, to ensure that voice traffic associated with VoIP dial peer 103 is given a higher priority than other IP network traffic, enter the following:

```
dial-peer voice 103 voip
 ip precedence 5
```

In this example, when an IP call leg is associated with VoIP dial peer 103, all packets transmitted to the IP network through this dial peer have their precedence bits set to 5. If the networks receiving these packets have been configured to recognize precedence bits, the packets are given priority over packets with a lower configured precedence value.

## Configure RSVP for Dial Peers

If you have configured your WAN or LAN interfaces for RSVP, you must configure the QoS for any associated VoIP peers. To configure quality of service for a selected VoIP peer, use the following commands, beginning in global configuration mode:

|        | Command                                                                                  | Purpose                                                          |
|--------|------------------------------------------------------------------------------------------|------------------------------------------------------------------|
| Step 1 | <b>dial-peer voice</b> <i>number</i> <b>voip</b>                                         | Enter the dial-peer configuration mode to configure a VoIP peer. |
| Step 2 | <b>req-qos</b> [ <b>best-effort</b>   <b>controlled-load</b>   <b>guaranteed-delay</b> ] | Specify the desired quality of service to be used.               |



### Note

We suggest that you select **controlled-load** for the requested quality of service.

For example, to specify guaranteed delay QoS for VoIP dial peer 108, enter the following:

```
dial-peer voice 108 voip
 destination-pattern +1408528
 req-qos controlled-load
 session target ipv4:10.0.0.8
```

In this example, every time a connection is made through VoIP dial peer 108, an RSVP reservation request is made between the local router, all intermediate routers in the path, and the final destination router.

To generate an SNMP trap message if the reserved QoS is less than the configured value for a selected VoIP peer, use the following commands, beginning from the global configuration mode:

|        | Command                                                                                  | Purpose                                                           |
|--------|------------------------------------------------------------------------------------------|-------------------------------------------------------------------|
| Step 1 | <b>dial-peer voice</b> <i>number</i> <b>voip</b>                                         | Enter the dial-peer configuration mode to configure a VoIP peer.  |
| Step 2 | <b>acc-qos</b> [ <b>best-effort</b>   <b>controlled-load</b>   <b>guaranteed-delay</b> ] | Specify the QoS value below which an SNMP trap will be generated. |



**Note**

RSVP reservations are only one-way. If you configure RSVP, the VoIP dial peers on both ends of the connection must be configured for RSVP.

## Configure Codec and VAD for Dial Peers

Coder-decoder (codec) and voice activity detection (VAD) for a dial peer determine how much bandwidth the voice session uses. Typically, codec is used to transform analog signals into a digital bit stream and digital signals back into analog signals—in this case, it specifies the voice coder rate of speech for a dial peer. VAD is used to disable the transmission of silence packets.

### Configure Codec for a VoIP Dial Peer

To specify a voice coder rate for a selected VoIP peer, use the following commands, initially beginning in global configuration mode:

|        | Command                                          | Purpose                                                          |
|--------|--------------------------------------------------|------------------------------------------------------------------|
| Step 1 | <b>dial-peer voice</b> <i>number</i> <b>voip</b> | Enter the dial-peer configuration mode to configure a VoIP peer. |
| Step 2 | <b>codec</b> [g711alaw   g711ulaw   g729r8]      | Specify the desired voice coder rate of speech.                  |

The default for the **codec** command is **g729r8**; normally the default configuration for this command is the most desirable. If, however, you are operating on a high-bandwidth network and voice quality is of the highest importance, you should configure the **codec** command for **g711alaw** or **g711ulaw**. Using these values results in better voice quality, but it also requires higher bandwidth requirements for voice.

For example, to specify a codec rate of G.711a-law for VoIP dial peer 108, enter the following:

```
dial-peer voice 108 voip
 destination-pattern +1408528
 codec g711alaw
 session target ipv4:10.0.0.8
```

### Configure VAD for a VoIP Dial Peer

To disable the transmission of silence packets for a selected VoIP peer, use the following commands, beginning in global configuration mode:

|        | Command                                          | Purpose                                                          |
|--------|--------------------------------------------------|------------------------------------------------------------------|
| Step 1 | <b>dial-peer voice</b> <i>number</i> <b>voip</b> | Enter the dial-peer configuration mode to configure a VoIP peer. |
| Step 2 | <b>vad</b>                                       | Disable the transmission of silence packets (enabling VAD).      |

The default for the **vad** command is enabled; normally the default configuration for this command is the most desirable. If you are operating on a high-bandwidth network and voice quality is of the highest importance, you should disable vad. Using this value will result in better voice quality, but it will also require higher bandwidth requirements for voice.

For example, to enable VAD for VoIP dial peer 108, enter the following:

```
dial-peer voice 108 voip
destination-pattern +1408528
vad
session target ipv4:10.0.0.8
```

## Configuring Voice over Frame Relay

You need to take certain factors into consideration when configuring VoIP for it to run smoothly over Frame Relay. A public Frame Relay cloud provides no guarantees for QoS. For real-time traffic to be transmitted in a timely manner, the data rate must not exceed the committed information rate (CIR), or there is the possibility that packets will be dropped. In addition, Frame Relay traffic shaping and RSVP are mutually exclusive. This is particularly important to remember if multiple data-link connection identifiers (DLCIs) are carried on a single interface.

For Frame Relay links with slow output rates (less than or equal to 64 kbps), where data and voice are being transmitted over the same PVC, we recommend the following solutions:

- Separate DLCIs for voice and data—By providing a separate subinterface for voice and data, you can use the appropriate QoS tool per line. For example, each DLCI would use 32 kbps of a 64 kbps line.
  - Apply adaptive traffic shaping to both DLCIs.
  - Use RSVP or IP precedence to prioritize voice traffic.
  - Use compressed RTP to minimize voice packet size.
  - Use weighted fair queuing to manage voice traffic.
- Lower MTU size—Voice packets are generally small. By lowering the maximum transmission unit (MTU) size (for example, to 300 bytes), large data packets can be broken up into smaller data packets that can more easily be interwoven with voice packets.



---

**Note** Lowering the MTU size affects data throughput speed.

---

- CIR equal to line rate—Make sure that the data rate does not exceed the CIR. This is accomplished through generic traffic shaping.
  - Use RSVP or IP precedence to prioritize voice traffic.
  - Use compressed RTP to minimize voice packet header size.
- Traffic shaping—Use adaptive traffic shaping to throttle back the output rate based on the backward explicit congestion notification (BECN). If the feedback from the switch is ignored, packets (both data and voice) might be discarded. Because the Frame Relay switch does not distinguish between voice and data packets, voice packets could be discarded, which would result in a deterioration of voice quality.
  - Use RSVP, compressed RTP, reduced MTU size, and adaptive traffic shaping based on BECN to hold the data rate to the CIR.
  - Use generic traffic shaping to obtain a low interpacket wait time. For example, set Bc to 4000 to obtain an interpacket wait of 125 ms.

## Voice over Frame Relay Configuration Example

For Frame Relay, it is customary to configure a main interface and several subinterfaces, one subinterface per PVC. The following example configures a Frame Relay main interface and a subinterface so that voice and data traffic can be successfully transported:

```
interface serial 1/1
MTU 300
no ip address
encapsulation frame-relay
no ip route-cache
no ip mroute-cache
fair-queue 64 256 1000
frame-relay ip rtp header-compression

interface serial 1/1.1
MTU 300
ip address 10.0.0.5 255.0.0.0
ip rsvp bandwidth 48 48
no ip route-cache
no ip mroute-cache
bandwidth 64
traffic-shape rate 32000 4000 4000
frame-relay interface-dlci 16
frame-relay ip rtp header-compression
```

In this configuration example, the main interface has been configured as follows:

- MTU size is 300 bytes.
- No IP address is associated with this serial interface. The IP address must be assigned for the subinterface.
- Encapsulation method is Frame Relay.
- Fair queuing is enabled.
- IP RTP header compression is enabled

The subinterface has been configured as follows:

- MTU size is inherited from the main interface.
- IP address for the subinterface is specified.
- Bandwidth is set to 64 kbps.
- RSVP is enabled to use the default value, which is 75 percent of the configured bandwidth.
- Generic traffic shaping is enabled with 32 kbps CIR where Bc = 4000 bits and Be = 4000 bits.
- Frame Relay DLCI number is specified.
- IP RTP header compression is enabled.

**Note**

When traffic bursts over the CIR, output rate is held at the speed configured for the CIR (for example, traffic will not go beyond 32 kbps if the CIR is set to 32 kbps).

For more information about Frame Relay, refer to the Cisco IOS Release 12.0 *Wide-Area Networking Configuration Guide*.

# Checking the Configuration

After configuring the new interface, use the **show** commands to display the status of the new interface or all interfaces, and use the **ping** command to check connectivity. This section includes the following subsections:

- Using show Commands to Verify the New Interface Status, page 4-34
- Using loopback Commands, page 4-42

## Using show Commands to Verify the New Interface Status

Table 4-4 demonstrates how you can use the **show** commands to verify that new interfaces are configured and operating correctly and that the PA-VXA, PA-VXB, or PA-VXC port adapter appears in them correctly. Sample displays of the output of selected **show** commands appear in the sections that follow. For complete command descriptions and examples, refer to the publications listed in the “Related Documentation” section on page viii.

### Troubleshooting Tips

If information about the port adapter is not indicated in show command output, it is probably because the card type has not been specified.

Because the port adapter can be configured for E1 or T1 connectivity, you must specify the card type as E1 or T1, as described in “Performing a Basic Configuration” section on page 4-4. There is no default card type. The port adapter is not functional until the card type is set.



#### Note

The outputs that appear in this document may not match the output you receive when running these commands. The outputs in this document are examples only.

**Table 4-4** Using show Commands

| Command                                        | Function                                                                                                                                                                   | Example                         |
|------------------------------------------------|----------------------------------------------------------------------------------------------------------------------------------------------------------------------------|---------------------------------|
| <b>show version</b> or<br><b>show hardware</b> | Displays system hardware configuration, the number of each interface type installed, Cisco IOS software version, names and sources of configuration files, and boot images | Router# <b>show version</b>     |
| <b>show controllers</b>                        | Displays all the current interface processors and their interfaces                                                                                                         | Router# <b>show controllers</b> |
| <b>show diag slot</b>                          | Displays types of port adapters installed in your system and information about a specific port adapter slot, interface processor slot, or chassis slot                     | Router# <b>show diag 2</b>      |

Table 4-4 Using show Commands (continued)

| Command                                                                                                | Function                                                                                                                                                                                        | Example                                    |
|--------------------------------------------------------------------------------------------------------|-------------------------------------------------------------------------------------------------------------------------------------------------------------------------------------------------|--------------------------------------------|
| <b>show interfaces</b> <i>type</i><br><i>port-adapter-slot-number/</i><br><i>interface-port-number</i> | Displays status information about a specific type of interface (for example, DSPfarm) in Cisco 7200 series routers, Cisco 7200 VXR routers, Cisco 7401ASR routers, or Cisco 7500 series routers | Router# <b>show interfaces DSPfarm 1/0</b> |
| <b>show protocols</b>                                                                                  | Displays protocols configured for the entire system and for specific interfaces                                                                                                                 | Router# <b>show protocols</b>              |
| <b>show running-config</b>                                                                             | Displays the running configuration file                                                                                                                                                         | Router# <b>show running-config</b>         |
| <b>show startup-config</b>                                                                             | Displays the configuration stored in NVRAM                                                                                                                                                      | Router# <b>show startup-config</b>         |

If an interface is shut down and you configured it as up, or if the displays indicate that the hardware is not functioning properly, ensure that the interface is properly connected and terminated. If you still have problems bringing up the interface, contact a service representative for assistance. This section includes the following subsections and offers some platform-specific output examples:

- Using the show version or show hardware Commands, page 4-35
- Using the show diag Command, page 4-37
- Using the show interfaces Command, page 4-40

Choose the subsection appropriate for your system. Proceed to the “Using loopback Commands” section on page 4-42 when you have finished using the **show** commands.

## Using the show version or show hardware Commands

Use the **show version** (or **show hardware**) command to display the configuration of the system hardware, the number of each interface type installed, the Cisco IOS software version, the names and sources of configuration files, and the boot images.



### Note

The outputs that appear in this document may not match the output you receive when running these commands. The outputs in this document are examples only.

### Cisco 7200 Series and Cisco 7200 VXR Routers

Following is an example of the **show version** command from a Cisco 7206VXR router:

```
Router# show version

Cisco Internetwork Operating System Software
IOS (tm) 7200 Software (C7200-IS-M), Version 12.0(5)XE3,
TAC:Home:SW:IOS:Specials for info
Copyright (c) 1986-1999 by cisco Systems, Inc.
Compiled Sat 20-Nov-99 10:51 by en
Image text-base: 0x60008900, data-base: 0x6139A000
```

```

ROM: System Bootstrap, Version 12.0(19990210:195103) [12.0XE 105],
BOOTFLASH: 7200 Software (C7200-IS-M), Version 12.0(5)XE3,

Router uptime is 4 days, 21 hours, 8 minutes
System returned to ROM by reload
System image file is "slot0:c7200-is-mz.120-5.XE3"

cisco 7206VXR (NPE300) processor with 57344K/40960K bytes of memory.
R7000 CPU at 262Mhz, Implementation 39, Rev 1.0, 256KB L2, 2048KB L3 Cache
6 slot VXR midplane, Version 2.0

Last reset from power-on
Bridging software.
X.25 software, Version 3.0.0.
Primary Rate ISDN software, Version 1.1.
1 FastEthernet/IEEE 802.3 interface(s)
1 ATM network interface(s)
10 Channelized T1/PRI port(s)
5 Voice resource(s)
125K bytes of non-volatile configuration memory.

20480K bytes of Flash PCMCIA card at slot 0 (Sector size 128K).
8192K bytes of Flash PCMCIA card at slot 1 (Sector size 128K).
4096K bytes of Flash internal SIMM (Sector size 256K).
Configuration register is 0x0

```

## Cisco 7401ASR Routers

Following is an example of the **show version** command from a Cisco 7401ASR router with the PA-VXB-2TE1+ port adapter shown as a voice resource:

```

Router# show version

Cisco Internetwork Operating System Software
IOS (tm) 7401ASR Software (C7401ASR-IS-M), Version 12.0(5)XE3,
TAC:Home:SW:IOS:Specials for info
Copyright (c) 1986-1999 by cisco Systems, Inc.
Compiled Sat 20-Nov-99 10:51 by en
Image text-base: 0x60008900, data-base: 0x6139A000

ROM: System Bootstrap, Version 12.0(19990210:195103) [12.0XE 105],
BOOTFLASH: 7401ASR Software (C7401ASR-IS-M), Version 12.0(5)XE3,

Router uptime is 4 days, 21 hours, 8 minutes
System returned to ROM by reload
System image file is "slot1:c7401ASR-is-mz.120-5.XE3"

Last reset from power-on
Bridging software.
X.25 software, Version 3.0.0.
Primary Rate ISDN software, Version 1.1.
1 FastEthernet/IEEE 802.3 interface(s)
1 ATM network interface(s)
10 Channelized T1/PRI port(s)
5 Voice resource(s)
125K bytes of non-volatile configuration memory.

20480K bytes of Flash PCMCIA card at slot 0 (Sector size 128K).
8192K bytes of Flash PCMCIA card at slot 1 (Sector size 128K).
4096K bytes of Flash internal SIMM (Sector size 256K).
Configuration register is 0x0

```

## Cisco 7500 Series Routers

Following is an example of the **show version** command from a Cisco 7500 series router:

```
Router# show version

Cisco Internetwork Operating System Software
IOS (tm) RSP Software (RSP-ISV-M), Version 12.1(20000613:174753) []
Copyright (c) 1986-2000 by cisco Systems, Inc.
Compiled Wed 28-Jun-00 18:59 by ang
Image text-base: 0x60010968, data-base: 0x613FC000

ROM: System Bootstrap, Version 5.3(16645) [ang 571],RELEASE SOFTWARE
BOOTFLASH: GS Software (RSP-BOOT-M), Version 11.1(5654)XX [mwu 105]

cheng10 uptime is 14 hours, 6 minutes
System returned to ROM by power-on
System image file is "tftp://223.255.254.254/muck/ang/rsp-isv-mz.1213t"

cisco RSP2 (R4600) processor with 81920K/2072K bytes of memory.
R4600 CPU at 100Mhz, Implementation 32, Rev 2.0
Last reset from power-on
G.703/E1 software, Version 1.0.
G.703/JT2 software, Version 1.0.
X.25 software, Version 3.0.0.
Bridging software.
Primary Rate ISDN software, Version 1.1.
Chassis Interface.
1 VIP2 controller (4 T1)(1 ATM)(2 Voice resources).
2 VIP2 R5K controllers (8 Ethernet)(4 T1)(1 ATM)(2 Voice resources).
8 Ethernet/IEEE 802.3 interface(s)
24 Serial network interface(s)
2 ATM network interface(s)
125K bytes of non-volatile configuration memory.

20480K bytes of Flash PCMCIA card at slot 0 (Sector size 128K).
20480K bytes of Flash PCMCIA card at slot 1 (Sector size 128K).
8192K bytes of Flash internal SIMM (Sector size 256K).
Configuration register is 0x100
```

## Using the show diag Command

Display the types of port adapters installed in your system (and specific information about each) using the **show diag slot** command, where *slot* is the *port adapter slot* in Cisco 7200 series routers, Cisco 7200 VXR routers, and Cisco 7401ASR routers, and the *interface processor slot* in a Cisco 7500 series router.



### Note

The outputs that appear in this document may not match the output you receive when running these commands. The outputs in this document are examples only.

## Cisco 7200 Series and Cisco 7200 VXR Routers

Following is an example of the **show diag slot** command that shows a PA-VXC-2TE1 in port adapter slot 1 of a Cisco 7200 series router:

```
Router# show diag 1
Slot 1:
    VXC-2T1/E1 Port adapter, 2 ports
    Port adapter is analyzed
```

```

Port adapter insertion time 4d21h ago
EEPROM contents at hardware discovery:
Hardware revision 1.0          Board revision K0
Serial number 14320311        Part number 73-3861-03
Test history 0x0             RMA number 00-00-00
EEPROM format version 1
EEPROM contents (hex):
0x20: 01 CF 01 00 00 DA 82 B7 49 0F 15 03 00 00 00 00
0x30: A0 00 00 00 00 00 00 00 00 00 00 00 00 00 00 00

```

**Note**

Port adapters used with Cisco 7200 VXR routers require the correct base hardware revision in order to function. Use the **show diag** command to display the hardware revision.

**Cisco 7401ASR Routers**

Following is an example of the **show diag slot** command that shows a PA-VXB-2TE1+ port adapter in port adapter slot 1 of a Cisco 7401ASR router:

```

Router# show diag 1
Slot 1:
VXB-2T1/E1+ Port adapter, 2 ports
Port adapter is analyzed
Port adapter insertion time 4d21h ago
EEPROM contents at hardware discovery:
Hardware revision 1.0          Board revision K0
Serial number 14320311        Part number 73-3861-03
Test history 0x0             RMA number 00-00-00
EEPROM format version 1
EEPROM contents (hex):
0x20: 01 CF 01 00 00 DA 82 B7 49 0F 15 03 00 00 00 00
0x30: A0 00 00 00 00 00 00 00 00 00 00 00 00 00 00 00

```

**Cisco 7500 Series Routers**

Following is an example of the **show diag slot** command that shows a PA-VXC-2TE1+ in interface processor slot 1 of a Cisco 7500 series router:

```

Router# show diag 1
Slot 1:
Physical slot 1, ~physical slot 0xE, logical slot 1, CBus 0
Microcode Status 0x4
Master Enable, LED, WCS Loaded
Board is analyzed
Pending I/O Status: None
EEPROM format version 1
VIP2 R5K controller, HW rev 2.02, board revision A0
Serial number: 10945159 Part number: 73-2167-05
Test history: 0x00 RMA number: 00-00-00
Flags: cisco 7000 board; 7500 compatible

EEPROM contents (hex):
0x20: 01 1E 02 02 00 A7 02 87 49 08 77 05 00 00 00 00
0x30: 50 00 00 01 00 00 00 00 00 00 00 00 00 00 00 00

Slot database information:
Flags: 0x4 Insertion time: 0x288C (3d19h ago)

Controller Memory Size: 128 MBytes DRAM, 8192 KBytes SRAM

PA Bay 0 Information:

```



```
VXC-2T1/E1+ Port adapter, 2 ports  
EEPROM format version 4  
HW rev 0.02, Board revision A0  
Serial number: MIC04251WXZ Part number: 73-5340-03
```

```

PA Bay 1 Information:
  VXC-2T1/E1 Port adapter, 2 ports
  EEPROM format version 1
  HW rev 0.01, Board revision A0
  Serial number: 15234366 Part number: 73-3861-03

```

## Using the show interfaces Command

The **show interfaces** command displays status information (including the physical slot and interface address) for the interfaces you specify. All of the examples that follow specify DSPfarm interfaces.

For complete descriptions of interface subcommands and the configuration options available for router interfaces, refer to the publications listed in the “Related Documentation” section on page viii.



### Note

The outputs that appear in this document may not match the output you receive when running these commands. The outputs in this document are examples only.

## Cisco 7200 Series and Cisco 7200 VXR Routers

Following is an example of the **show interfaces DSPfarm** command for Cisco 7200 series routers. In this example, the PA-VXC-2TE1 port adapter is located in port adapter slot 1.

```

Router# show interfaces DSPfarm 1/0
DSPfarm1/0 is up, line protocol is up
  Hardware is VXC-2T1/E1
  MTU 256 bytes, BW 12000 Kbit, DLY 0 usec,
    reliability 255/255, txload 1/255, rxload 1/255
  Encapsulation ARPA, loopback not set
  C549 DSP Firmware Version: MajorRelease.MinorRelease (BuildNumber)
    DSP Boot Loader: 255.255 (255)
    DSP Application: 3.2 (10)
    Medium Complexity Application: 3.2 (12)
    High Complexity Application: 3.2 (12)
  Total DSPs 29, DSP0-DSP29, Jukebox DSP id 30
  Down DSPs: none
  Restarted DSPs due to background keep-alive failures DSPid(number of restart)e
  Total sig channels 116 used 48, total voice channels 116 used 0
    0 active calls, 24 max active calls, 163554 total calls
  CHT: 489702 total sec, 2 avg sec, 69 max sec
  230728928 rx packets, 0 rx drops, 239246561 tx packets, 0 tx frags
    0 curr_dsp_tx_queued, 12 max_dsp_tx_queued
  Last input never, output never, output hang never
  Last clearing of "show interface" counters 4d20h
  Queueing strategy: fifo
  Output queue 0/0, 0 drops; input queue 0/75, 0 drops
  5 minute input rate 0 bits/sec, 0 packets/sec
  5 minute output rate 0 bits/sec, 0 packets/sec
    228929291 packets input, 574310582 bytes, 0 no buffer
    Received 0 broadcasts, 0 runts, 0 giants, 0 throttles
    0 input errors, 0 CRC, 0 frame, 0 overrun, 0 ignored, 0 abort
    239246561 packets output, 626450944 bytes, 0 underruns
    0 output errors, 0 collisions, 0 interface resets
    0 output buffer failures, 0 output buffers swapped out

```

## Cisco 7401ASR Routers

Following is an example of the **show interfaces DSPfarm** command for Cisco 7401ASR routers. In this example, the PA-VXB-2TE1+ port adapter is located in port adapter slot 1.

```

Router# show interfaces DSPfarm 1/0
DSPfarm1/0 is up, line protocol is up
  Hardware is VXB-2T1/E1+
  MTU 256 bytes, BW 12000 Kbit, DLY 0 usec,
    reliability 255/255, txload 1/255, rxload 1/255
  Encapsulation ARPA, loopback not set
  C549 DSP Firmware Version: MajorRelease.MinorRelease (BuildNumber)
    DSP Boot Loader: 255.255 (255)
    DSP Application: 3.2 (10)
    Medium Complexity Application: 3.2 (12)
    High Complexity Application: 3.2 (12)
  Total DSPs 29, DSP0-DSP29, Jukebox DSP id 30
  Down DSPs: none
  Restarted DSPs due to background keep-alive failures DSPid(number of restart)e

Total sig channels 116 used 48, total voice channels 116 used 0
  0 active calls, 24 max active calls, 163554 total calls
  CHT: 489702 total sec, 2 avg sec, 69 max sec
  230728928 rx packets, 0 rx drops, 239246561 tx packets, 0 tx frags
  0 curr_dsp_tx_queued, 12 max_dsp_tx_queued
Last input never, output never, output hang never
Last clearing of "show interface" counters 4d20h
Queueing strategy: fifo
Output queue 0/0, 0 drops; input queue 0/75, 0 drops
5 minute input rate 0 bits/sec, 0 packets/sec
5 minute output rate 0 bits/sec, 0 packets/sec
  228929291 packets input, 574310582 bytes, 0 no buffer
  Received 0 broadcasts, 0 runts, 0 giants, 0 throttles
  0 input errors, 0 CRC, 0 frame, 0 overrun, 0 ignored, 0 abort
  239246561 packets output, 626450944 bytes, 0 underruns
  0 output errors, 0 collisions, 0 interface resets
  0 output buffer failures, 0 output buffers swapped out

```

## Cisco 7500 Series Routers

Following is an example of the **show interfaces DSPfarm** command for Cisco 7500 series routers. In this example, the PA-VXC-2TE1+ port adapter is located in port adapter slot 0 on a VIP motherboard installed in interface processor slot 1.

```

Router# show interfaces DSPfarm 1/0/0
DSPfarm1/0/0 is up, line protocol is up
  Hardware is VXC-2T1/E1-PLUS
  MTU 256 bytes, BW 12000 Kbit, DLY 0 usec,
    reliability 255/255, txload 1/255, rxload 1/255
  Encapsulation VOICE, loopback not set
  C549 DSP Firmware Version: MajorRelease.MinorRelease (BuildNumber)
    DSP Boot Loader: 3.4 (1)
    DSP Application: 3.2 (10)
    Medium Complexity Application: 3.4 (25)
    High Complexity Application: 3.4 (25)
  Total DSPs 30, DSP0-DSP29, Jukebox DSP id 30
  Down DSPs: none
  DSPs restarted: none
  Total sig channels 120 used 47, total voice channels 120 used 24
    24 active calls, 47 max active calls, 1196 total calls
    CHT: 3566 total sec, 2 avg sec, 33 max sec
    0 curr_dsp_tx_queued, 22 max_dsp_tx_queued
Last input 00:00:00, output 00:00:00, output hang never
Last clearing of "show interface" counters never
Queueing strategy: fifo
Output queue 0/40, 0 drops; input queue 0/75, 0 drops
5 minute input rate 85000 bits/sec, 65 packets/sec
5 minute output rate 75000 bits/sec, 65 packets/sec

```

```

5651409 packets input, 683571491 bytes, 0 no buffer
Received 0 broadcasts, 0 runts, 0 giants, 0 throttles
0 input errors, 0 CRC, 0 frame, 0 overrun, 0 ignored, 0 abort
5698903 packets output, 586641447 bytes, 0 underruns
0 output errors, 0 collisions, 0 interface resets
0 output buffer failures, 0 output buffers swapped out

```

Proceed to “Using loopback Commands” section on page 4-42 to check network connectivity of the PA-VXB or PA-VXC and the switch or router.

## Using loopback Commands

With the loopback test, you can detect and isolate equipment malfunctions by testing the connection between the PA-VXA, PA-VXB, or PA-VXC interface and a remote device such as a modem or a CSU/DSU. The **loopback** subcommand places an interface in loopback mode, which enables test packets that are generated from the **ping** command to loop through a remote device or compact serial cable. If the packets complete the loop, the connection is good. If not, you can isolate a fault to the remote device or compact serial cable in the path of the loopback test.

Depending on the mode of the port, issuing the **loopback** command checks the following paths:

- When no compact serial cable is attached to the PA-VXB or PA-VXC interface port, or if a DCE cable is attached to a port that is configured as line protocol up, the **loopback** command tests the path between the network processing engine and the interface port only (without leaving the network processing engine and port adapter).
- When a DTE cable is attached to the port, the **loopback** command tests the path between the network processing engine and the near (network processing engine) side of the DSU or modem to test the PA-VXB or PA-VXC interface and compact serial cable.

## T1 Loopback Examples

Specify loopback for a T1 controller and T1 channel using the **loopback** command. There are three main loopback modes: diagnostic, local (line and payload), and remote (IBOC and ESF). Specify the loopback format using the **loopback [diagnostic | local | remote]** command.



### Note

To shut down the T1 controller, use the **shutdown** command at the controller prompt.

Examples of specific loopback modes for the T1 controller follow:

- The syntax of the **loopback diagnostic** command is as follows:

```
loopback [diagnostic]
```

Set the first T1 into diagnostic loopback.

Cisco 7200 Series Routers:

```

Router# config t
Enter configuration commands, one per line. End with CNTL/Z.
Router(config)# controller t1 2/0
Router(config-controller)# loopback diagnostic

```

## Cisco 7401ASR Routers:

```
Router# config t
Enter configuration commands, one per line. End with CNTL/Z.
Router(config)# controller t1 1/0
Router(config-controller)# loopback diagnostic
```

## Cisco 7500 Series Routers:

```
Router# config t
Enter configuration commands, one per line. End with CNTL/Z.
Router(config)# controller t1 2/2/0
Router(config-controller)# loopback diagnostic
```

In the preceding examples, the **loopback diagnostic** command loops the outgoing transmit signal back to the receive signal and sends an alarm indication signal (AIS) to the network.

- The syntax of the **loopback local** command is as follows:

```
loopback [local {payload | line}]
```

Set the first T1 into local loopback.

## Cisco 7200 Series Routers:

```
Router# config t
Enter configuration commands, one per line. End with CNTL/Z.
Router(config)# controller t1 2/0
Router(config-controller)# loopback local payload
```

## Cisco 7401ASR Routers:

```
Router# config t
Enter configuration commands, one per line. End with CNTL/Z.
Router(config)# controller t1 1/0
Router(config-controller)# loopback local payload
```

## Cisco 7500 Series Routers:

```
Router# config t
Enter configuration commands, one per line. End with CNTL/Z.
Router(config)# controller t1 2/2/0
Router(config-controller)# loopback local payload
```

In the preceding examples, the **loopback local payload** command loops the incoming signal back to the line.

- The syntax of the **loopback remote** command follows:

```
loopback [remote {esf line | iboc | esf payload}]
```

Set the first T1 into remote line inband loopback.

## Cisco 7200 Series Routers:

```
Router# config t
Enter configuration commands, one per line. End with CNTL/Z.
Router(config)# controller t1 2/0
Router(config-controller)# loop remote esf line
```

## Cisco 7401ASR Routers:

```
Router# config t
Enter configuration commands, one per line. End with CNTL/Z.
Router(config)# controller t1 1/0
Router(config-controller)# loop remote esf line
```

Cisco 7500 Series Routers:

```
Router# config t
Enter configuration commands, one per line. End with CNTL/Z.
Router(config)# controller t1 2/2/0
Router(config-controller)# loop remote esf line
```

This command causes the far end to loop its receive signal back to transmit.

## E1 Loopback Examples

Specify loopback for an E1 controller using the **loopback** command. There are two main loopback modes: diagnostic and local (line and payload). Specify the loopback format using the **loopback [diagnostic | local]** command.



### Note

To shut down the E1 controller, use the **shutdown** command at the controller prompt.

Examples of specific loopback modes for the E1 controller follow:

- The syntax of the **loopback diagnostic** command is as follows:

```
loopback [diagnostic]
```

Set the first E1 into diagnostic loopback.

Cisco 7200 Series Routers:

```
Router# config t
Enter configuration commands, one per line. End with CNTL/Z.
Router(config)# controller E1 2/0
Router(config-controller)# loopback diagnostic
```

Cisco 7401ASR Routers:

```
Router# config t
Enter configuration commands, one per line. End with CNTL/Z.
Router(config)# controller E1 1/0
Router(config-controller)# loopback diagnostic
```

Cisco 7500 Series Routers:

```
Router# config t
Enter configuration commands, one per line. End with CNTL/Z.
Router(config)# controller E1 2/2/0
Router(config-controller)# loopback diagnostic
```

In the preceding examples, the **loopback diagnostic** command loops the outgoing transmit signal back to the receive signal and sends an AIS out to the network.

- The syntax of the **loopback local** command is as follows:

```
loopback [local {payload | line}]
```

Set the first E1 into local loopback.

Cisco 7200 Series Routers:

```
Router# config t
Enter configuration commands, one per line. End with CNTL/Z.
Router(config)# controller E1 2/0
Router(config-controller)# loopback local payload
```

**Cisco 7401ASR Routers:**

```
Router# config t  
Enter configuration commands, one per line. End with CNTL/Z.  
Router(config)# controller E1 1/0  
Router(config-controller)# loopback local payload
```

**Cisco 7500 Series Routers:**

```
Router# config t  
Enter configuration commands, one per line. End with CNTL/Z.  
Router(config)# controller E1 2/2/0  
Router(config-controller)# loopback local payload
```

In the preceding examples, the **loopback local** command loops the incoming signal back to the line.

