



Broadband Access Aggregation and DSL Configuration Guide, Cisco IOS XE Fuji 16.8.x

Americas Headquarters

Cisco Systems, Inc.
170 West Tasman Drive
San Jose, CA 95134-1706
USA
<http://www.cisco.com>
Tel: 408 526-4000
800 553-NETS (6387)
Fax: 408 527-0883



CONTENTS

CHAPTER 1

Read Me First 1

CHAPTER 2

Preparing for Broadband Access Aggregation 3

- Finding Feature Information 3
- Prerequisites for Preparing for Broadband Access Aggregation 4
- Restrictions for Preparing for Broadband Access Aggregation 4
- Information About Preparing for Broadband Access Aggregation 4
 - Virtual Access Interfaces 4
 - Configuration Enhancements for Broadband Scalability 5
 - Virtual Access Subinterfaces 5
 - Virtual Template Compatibility with Subinterfaces 5
 - Benefits of Broadband Scalability Features 5
- How to Prepare for Broadband Access Aggregation 6
 - Configuring a Virtual Template Interface 6
 - Configuring Enhancements for Broadband Scalability 7
 - Verifying Virtual Template Compatibility with Virtual Access Subinterfaces 7
- Configuration Examples for Preparing for Broadband Access Aggregation 8
 - Virtual Access Subinterfaces Configuration Examples 8
 - Virtual Access Subinterface Configuration Example 9
 - Testing a Virtual Template for Compatibility with Subinterfaces Example 10
- Additional References 10
- Feature Information for Preparing for Broadband Access Aggregation 12

CHAPTER 3

Providing Protocol Support for Broadband Access Aggregation of PPPoE Sessions 13

- Finding Feature Information 13
- Prerequisites for Providing Protocol Support for Broadband Access Aggregation of PPPoE Sessions 14

Restrictions for Providing Protocol Support for Broadband Access Aggregation of PPPoE Sessions	14
Information About Providing Protocol Support for Broadband Access Aggregation for PPPoE Sessions	15
PPPoE Specification Definition	15
PPPoE Connection Throttling	15
PPPoE VLAN Session Throttling	15
Autosense for ATM PVCs	16
Benefits of Autosense for ATM PVCs	16
MAC Address for PPPoEoA	16
Benefits of the Configurable MAC Address for PPPoE Feature	17
How to Provide Protocol Support for Broadband Access Aggregation of PPPoE Sessions	17
Defining a PPPoE Profile	17
Enabling PPPoE on an Interface	19
Assigning a PPPoE Profile to an ATM PVC	20
Assigning a PPPoE Profile to an ATM PVC Range and PVC Within a Range	22
Assigning a PPPoE Profile to an ATM VC Class	24
Configuring Different MAC Addresses on PPPoE	26
Configuring PPPoE Session Recovery After Reload	28
Troubleshooting Tips	29
Monitoring and Maintaining PPPoE Profiles	29
Configuration Examples for Providing Protocol Support for Broadband Access Aggregation of PPPoE Sessions	30
Example: PPPoE Profiles Configuration	30
Example: MAC Address of the PPPoEoA Session as the Burned-In MAC Address	31
Example Address Autoselect Configured and MAC Address Not Configured	32
Example: MAC Address Configured on the ATM Interface	32
Example: MAC Address Configured on the BBA Group	33
Example: PPPoE Session Recovery After Reload	33
Where to Go Next	34
Additional References	34
Feature Information for Providing Protocol Support for Broadband Access Aggregation of PPPoE Sessions	36

Finding Feature Information	37
Information About PPP for IPv6	37
Accounting Start and Stop Messages	37
Forced Release of a Binding	38
Delegated-IPv6-Prefix	38
PPP IPv6 Accounting Delay Enhancements	38
How to Configure PPP for IPv6	39
Enabling the Sending of Accounting Start and Stop Messages	39
Removing Delegated Prefix Bindings	40
Configuring PPP IPv6 Accounting Delay Enhancements	41
Configuration Examples for PPP for IPv6	41
Example: Enabling the Sending of Accounting Start and Stop Messages	41
Additional References	42
Feature Information for PPP for IPv6	43

CHAPTER 5
DHCP for IPv6 Broadband 45

Finding Feature Information	45
Information About DHCP for IPv6 Broadband	45
Prefix Delegation	45
Accounting Start and Stop Messages	46
Forced Release of a Binding	46
How to Configure DHCP for IPv6 Broadband	46
Enabling the Sending of Accounting Start and Stop Messages	46
Removing Delegated Prefix Bindings	47
Configuration Examples for DHCP for IPv6 Broadband	48
Example: Enabling the Sending of Accounting Start and Stop Messages	48
Example: Configuration for a Prefix Allocated from a Local Pool	48
Additional References	49
Feature Information for DHCP for IPv6 Broadband	50

CHAPTER 6
Providing Protocol Support for Broadband Access Aggregation of PPP over ATM Sessions 53

Finding Feature Information	53
Prerequisites for Providing Protocol Support for Broadband Access Aggregation of PPP over ATM Sessions	54

Restrictions for Providing Protocol Support for Broadband Access Aggregation of PPP over ATM Sessions	54
Information About Providing Protocol Support for Broadband Access Aggregation of PPP over ATM Sessions	54
Virtual Access Interface	54
How to Provide Protocol Support for Broadband Access Aggregation of PPP over ATM Sessions	55
Configuring IETF-Compliant MUX Encapsulated PPP over ATM on Point-to-Point Subinterface	55
Configuring IETF-Compliant MUX Encapsulated PPP over ATM on a Multipoint Subinterface	57
Configuring IETF-Compliant LLC Encapsulated PPP over ATM on a Point-to-point Subinterface	59
Configuring IETF-Compliant LLC Encapsulated PPP over ATM on a Multipoint Subinterface	62
Configuration Examples for PPP over ATM	65
IETF-Compliant MUX Encapsulated PPP over ATM Configuration	65
Example: ETF-Compliant PPP over ATM with Different Traffic-Shaping Parameters	65
Example: Two Routers with Back-to-Back PVCs	65
Example: Multiplexed Encapsulation Using VC Class	66
IETF-Compliant LLC Encapsulated PPP over ATM Configuration	66
Example: Configuring IETF-Compliant PPP over ATM LLC Encapsulation	66
Example: Overriding a Virtual Template for IETF-Compliant PPP over ATM	67
Example: Disabling IETF-Compliant PPP over ATM LLC Encapsulation on a Specific VC	67
Additional References	68
Feature Information for Providing Protocol Support for Broadband Access Aggregation of PPP over ATM Sessions	68
<hr/>	
CHAPTER 7	Providing Connectivity Using ATM Routed Bridge Encapsulation over PVCs
	71
Finding Feature Information	71
Prerequisites for Providing Connectivity Using ATM Routed Bridge Encapsulation over PVCs	72

Restrictions for Providing Connectivity Using ATM Routed Bridge Encapsulation over PVCs	72
Information About Providing Connectivity Using ATM Routed Bridge Encapsulation over PVCs	72
Overview on Bridged 1483 Encapsulated Traffic over ATM SVCs	72
ATM RBE Subinterface Grouping by PVC Range	73
DHCP Option 82 Support for RBE	73
DHCP Lease Limit per ATM RBE Unnumbered Interface	75
Benefits of Providing Connectivity Using ATM Routed Bridge Encapsulation	75
How to Configure ATM Routed Bridge Encapsulation over PVCs	76
Configuring ATM Routed Bridge Encapsulation Using PVCs	76
Configuring DHCP Option 82 for RBE	78
Configuring the DHCP Lease Limit	79
Troubleshooting the DHCP Lease Limit	80
Configuration Examples for Providing Connectivity Using ATM Routed Bridge Encapsulation	81
Example Configuring ATM RBE on PVCs	81
Example Configuring ATM RBE on an Unnumbered Interface	81
Example Concurrent Bridging and ATM RBE	82
Example DHCP Option 82 for RBE Configuration	82
Example DHCP Lease Limit	83
Additional References	83
Feature Information for Providing Connectivity Using ATM Routed Bridge Encapsulation	85

CHAPTER 8
PPPoE Circuit-Id Tag Processing 87

Finding Feature Information	87
Prerequisites for the PPPoE Circuit-Id Tag Processing Feature	87
Information About the PPPoE Circuit-Id Tag Processing Feature	88
Differences Between ATM- and Fast or Gigabit Ethernet-Based Broadband Access Networks	88
DSL Forum 2004-71 Solution	88
Approach for a Circuit-Id Tag in Ethernet-Based Broadband Access Networks	88
Benefits of the PPPoE Circuit-Id Tag Processing Feature	89
How to Configure the PPPoE Circuit-Id Tag Processing Feature	90
Configuring the PPPoE Circuit-Id Tag Processing Feature	90
Removing the PPPoE Circuit-Id Tag	91

Displaying the Session Activity Log	92
Configuration Examples for the PPPoE Circuit-Id Tag Processing Feature	93
Configuring PPPoE Circuit-Id Tag Processing Example	93
Configuring BRAS to Include a NAS-Port-Id Attribute Example	94
Removing the PPPoE Circuit-Id Tag Example	94
Additional References	94
Feature Information for PPPoE Circuit-Id Tag Processing	95

CHAPTER 9**Configuring PPP over Ethernet Session Limit Support 97**

Finding Feature Information	97
Information About Configuring PPP over Ethernet Session Limit Support	98
Benefits of Configuring PPP over Ethernet Session Limit Support	98
Trap Generation	98
How to Configure PPP over Ethernet Session Limit Support	98
Specifying the Maximum Number of PPPoE Sessions on a Router	98
Specifying the Maximum Number of PPPoE Sessions on a Gigabit Ethernet Interface	100
Configuring System-Wide Threshold Parameters	101
Configuration Examples for PPP over Ethernet Session Limit Support	103
Example Specifying the Maximum Number of PPPoE Sessions on a Router	103
Example Specifying the Maximum Number of PPPoE Sessions on a Gigabit Ethernet Interface	103
Example Configuring the System-wide Threshold Parameters	104
Additional References	104
Feature Information for Configuring PPP over Ethernet Session Limit Support	106

CHAPTER 10**PPPoE Session Limit Local Override 107**

Finding Feature Information	107
Information About PPPoE Session Limit Local Override	107
How PPPoE Session Limit Local Override Works	107
How to Configure PPPoE Session Limit Local Override	108
Enabling PPPoE Session Limit Local Override	108
Configuration Examples for PPPoE Session Limit Local Override	110
Enabling PPPoE Session Limit Local Override Example	110
Additional References	110
Feature Information for PPPoE Session Limit Local Override	111

CHAPTER 11**PPPoE QinQ Support 113**

- Finding Feature Information 113
- Prerequisites for PPPoE QinQ Support 113
- Information About PPPoE QinQ Support 114
 - PPPoE QinQ Support on Subinterfaces 114
 - Broadband Ethernet-Based DSLAM Model of QinQ VLANs 115
 - Unambiguous and Ambiguous Subinterfaces 116
- How to Configure PPPoE QinQ Support 117
 - Configuring the Interfaces for PPPoE QinQ Support 117
 - Verifying the PPPoE QinQ Support 120
- Configuration Examples for PPPoE QinQ Support 121
 - Configuring the any Keyword on Subinterfaces for PPPoE QinQ Support Example 121
- Additional References 123
- Feature Information for PPPoE QinQ Support 125

CHAPTER 12**PPP-Max-Payload and IWF PPPoE Tag Support 127**

- Finding Feature Information 127
- Information About PPP-Max-Payload and IWF PPPoE Tag Support 128
 - Accommodating an MTU MRU Greater than 1492 in PPPoE 128
 - Interworking Functionality 128
- How to Configure PPP-Max-Payload and IWF PPPoE Tag Support 128
 - Enabling PPP-Max-Payload and IWF PPPoE Tag Support 128
 - Disabling PPP-Max-Payload and IWF PPPoE Tag Support 131
- Configuration Examples for PPP-Max Payload and IWF PPPoE Tag Support 132
 - PPP-Max-Payload and IWF PPPoE Tag Support Enabled Example 132
 - PPP-Max-Payload and IWF PPPoE Tag Support Disabled Example 132
- Additional References 133
- Feature Information for PPP-Max-Payload and IWF PPPoE Tag Support 134

CHAPTER 13**PPPoE Session Limiting on Inner QinQ VLAN 135**

- Finding Feature Information 135
- Prerequisites for PPPoE Session Limiting on Inner QinQ VLAN 135
- Restrictions for PPPoE Session Limiting on Inner QinQ VLAN 136
- Information About PPPoE Session Limiting on Inner QinQ VLAN 136

Benefits of PPPoE Session Limiting on Inner QinQ VLAN	136
Feature Design of PPPoE Session Limiting on Inner QinQ VLAN	136
How to Configure PPPoE Session Limiting on Inner QinQ VLAN	137
Configuring PPPoE Session Limiting on Inner QinQ VLAN	137
Troubleshooting Tips	138
Configuration Examples for PPPoE Session Limiting on Inner QinQ VLAN	138
PPPoE Session Limiting on Inner QinQ VLAN Example	138
Additional References	138
Feature Information for PPPoE Session Limiting on Inner QinQ VLAN	140

CHAPTER 14

PPPoE Agent Remote-ID and DSL Line Characteristics Enhancement	141
Finding Feature Information	141
Prerequisites for the PPPoE Agent Remote-ID and DSL Line Characteristics Enhancement	142
Information About the PPPoE Agent Remote-ID and DSL Line Characteristics Enhancement	142
Differences Between ATM and Fast or Gigabit Ethernet-Based Broadband Access Networks	142
DSL Forum 2004-71 Solution for Remote-ID in PPPoE Discovery Phase	142
Remote-ID Tag in Fast or Gigabit Ethernet-Based Broadband Access Networks	143
Benefits of the PPPoE Agent Remote-ID and DSL Line Characteristics Enhancement	144
How to Configure the PPPoE Agent Remote-ID and DSL Line Characteristics Enhancement	144
Configuring the PPPoE Agent Remote-ID and DSL Line Characteristics Enhancement Feature	144
Stripping Vendor-Specific Tags	146
Troubleshooting Tips	147
Configuration Examples for PPPoE Agent Remote-ID and DSL Line Characteristics Enhancement	148
Configuring PPPoE Agent Remote-ID and DSL Line Characteristics Enhancement Example	148
Stripping Vendor-Specific Tags Example	148
Additional References	148
Feature Information for PPPoE Agent Remote-ID and DSL Line Characteristics Enhancement	150

Glossary 151

CHAPTER 15

Enabling PPPoE Relay Discovery and Service Selection Functionality 153

Finding Feature Information 153

Prerequisites for Enabling PPPoE Relay Discovery and Service Selection Functionality 154

Information About Enabling PPPoE Relay Discovery and Service Selection Functionality 154

L2TP Active Discovery Relay for PPPoE 154

How to Enable PPPoE Relay Discovery and Service Selection Functionality 154

Configuring the LAC and Tunnel Switch for PPPoE Relay 154

What to Do Next 156

Configuring the LNS (or Multihop Node) to Respond to Relayed PAD Messages 156

Monitoring PPPoE Relay 157

Troubleshooting Tips 159

Configuration Examples for Enabling PPPoE Relay Discovery and Service Selection
Functionality 159

PPPoE Relay on LAC Configuration Example 159

Basic LNS Configured for PPPoE Relay Example 160

Tunnel Switch (or Multihop Node) Configured to Respond to PAD Messages Example 161

Tunnel Switch Configured to Relay PAD Messages Example 162

RADIUS Subscriber Profile Entry for the LAC Example 163

RADIUS VPDN Group User Profile Entry for the LNS Example 163

Additional References 163

Feature Information for Enabling PPPoE Relay Discovery and Service Selection
Functionality 165

CHAPTER 16

Configuring Cisco Subscriber Service Switch Policies 167

Finding Feature Information 167

Prerequisites for Configuring a Subscriber Service Switch Policy 168

Restrictions for Configuring a Subscriber Service Switch Policy 168

Information About the Subscriber Service Switch 168

Benefits of the Subscriber Service Switch 168

Backward Compatibility of Subscriber Service Switch Policies 169

Debug Commands Available for Subscriber Service Switch 171

How to Configure a Subscriber Service Switch Policy 173

Enabling Domain Preauthorization on a NAS 173

What to Do Next	174
Creating a RADIUS User Profile for Domain Preauthorization	174
Enabling a Subscriber Service Switch Preauthorization	174
What to Do Next	176
Troubleshooting the Subscriber Service Switch	176
Configuration Examples for Configuring a Subscriber Service Switch Policy	178
LAC Domain Authorization Example	178
Domain Preauthorization RADIUS User Profile Example	178
Subscriber Service Switch Preauthorization Example	178
Verify Subscriber Service Switch Call Operation Example	179
Correlating the Unique ID in show vpdn session Command Output	180
Troubleshooting the Subscriber Service Switch Examples	180
Troubleshooting the Subscriber Service Switch Operation Example	181
Troubleshooting the Subscriber Service Switch on the LAC--Normal Operation Example	182
Troubleshooting the Subscriber Service Switch on the LAC--Authorization Failure Example	184
Troubleshooting the Subscriber Service Switch on the LAC--Authentication Failure Example	186
Troubleshooting the Subscriber Service Switch on the LNS--Normal Operation Example	188
Troubleshooting the Subscriber Service Switch on the LNS--Tunnel Failure Example	190
Where to Go Next	191
Additional References	192
Feature Information for Configuring a Subscriber Service Switch Policy	193

CHAPTER 17**AAA Improvements for Broadband IPv6 195**

Finding Feature Information	195
Information About AAA Improvements for Broadband IPv6	195
AAA over IPv6	195
AAA Support for IPv6 RADIUS Attributes	196
Prerequisites for Using AAA Attributes for IPv6	196
RADIUS Per-User Attributes for Virtual Access in IPv6 Environments	196
How to Enable AAA Improvements for Broadband IPv6	200

Sending IPv6 Counters to the Accounting Server	200
Configuration Examples for AAA Improvements for Broadband IPv6	201
Example: Sending IPv6 Counters to the Accounting Server	201
Additional References	201
Feature Information for AAA Improvements for Broadband IPv6	202

CHAPTER 18**Per Session Queuing and Shaping for PPPoEoVLAN Using RADIUS 203**

Finding Feature Information	203
Restrictions for Per Session Queuing and Shaping for PPPoEoVLAN Using RADIUS	204
Information About Per Session Queuing and Shaping for PPPoEoVLAN Using RADIUS	204
How Routers Apply QoS Policy to Sessions	205
How RADIUS Uses VSA 38 in User Profiles	205
Commands Used to Define QoS Actions	206
How to Use the Per Session Queuing and Shaping for PPPoEoVLAN Using RADIUS	
Feature	207
Configuring a Per Session Queuing and Shaping Policy on the Router	207
Verifying Per Session Queuing	210
Configuration Examples for Per Session Queuing and Shaping Policies	210
Configuring a Per Session Queuing and Shaping Policy on the Router Example	210
Setting Up RADIUS for Per Session Queuing and Shaping Example	211
Verifying Per Session Queuing and Shaping Policies Examples	211
Additional References	213
Feature Information for Per Session Queuing and Shaping for PPPoEoVLAN Using	
RADIUS	214

CHAPTER 19**802.1P CoS Bit Set for PPP and PPPoE Control Frames 215**

Finding Feature Information	215
Prerequisites for 802.1P CoS Bit Set for PPP and PPPoE Control Frames	215
Restrictions for 802.1P CoS Bit Set for PPP and PPPoE Control Frames	216
Information About 802.1P CoS Bit Set for PPP and PPPoE Control Frames	216
Benefits of 802.1P CoS Bit Set for PPP and PPPoE Control Frames	216
Feature Design of 802.1P CoS Bit Set for PPP and PPPoE Control Frames	216
How to Configure 802.1P CoS Bit Set for PPP and PPPoE Control Frames	217
Configuration Examples for 802.1P CoS Bit Set for PPP and PPPoE Control Frames	217
Setting 802.1P Priority Bits in 802.1Q Frames Containing PPPoE Control Packets	217

Additional References	219
Feature Information for 802.1P CoS Bit Set for PPP and PPPoE Control Frames	220

CHAPTER 20

PPP over Ethernet Client	221
Finding Feature Information	221
Prerequisites for PPP over Ethernet Client	221
Restrictions for PPP over Ethernet Client	222
Information About PPP over Ethernet Client	222
PPP over Ethernet Client Network Topology	222
PPP over Ethernet Client Session Initiation	223
How to Configure PPP over Ethernet Client	225
Configuring a PPPoE Client	225
Configuring PPPoE on the Server	228
Configuration Examples for the PPP over Ethernet Client	233
Example: Configuring a PPPoE Client	233
Example: Configuring PPPoE on IPv4	234
Example: Configuring PPPoE on IPv6 using DHCP	235
Example: Configuring PPPoE on IPv6	237
Additional References	239
Feature Information for PPP over Ethernet Client	240

CHAPTER 21

VRF Awareness Access Class Line	241
Feature Information for VRF Awareness Access Class Line	241
Restrictions for VRF Awareness Access-Class Line	242
Information About VRF Awareness Access Class Line	242
VRF Awareness Access Class Line	242
How to Configure VRF Awareness Access Class Line	242
Configure Access-Class on the VTY line	242
Configure Multiple Routing Tables or VRFs using Access-Class	243
Configuration Examples for VRF Awareness Access Class Line	243
Example: VRF Awareness Access-Class for IPv4 and IPv6	243
Additional References for VRF Awareness Access Class Line	243

CHAPTER 22

PPPoE Smart Server Selection	245
Finding Feature Information	245

Information About PPPoE Smart Server Selection	245
Benefits of PPPoE Smart Server Selection	245
How to Configure PPPoE Smart Server Selection	246
Configuring BBA Group PADO Delay	246
Troubleshooting Tips	247
Configuring PADO Delay Based on Remote ID or Circuit ID	247
Troubleshooting Tips	249
Configuring PPPoE Service PADO Delay	249
Troubleshooting Tips	251
Configuration Examples for PPPoE Smart Server Selection	252
Configuring BBA Group PADO Delay Example	252
Configuring PADO Delay Example	252
Configuring PPPoE Service PADO Delay Example	252
Verifying the PPPoE Service Match and PADO Delay Example	253
Additional References	253
Feature Information for PPPoE Smart Server Selection	254

CHAPTER 23

Monitoring PPPoE Sessions with SNMP	255
Finding Feature Information	255
Prerequisites for Monitoring PPPoE Sessions with SNMP	256
Restrictions for Monitoring PPPoE Sessions with SNMP	256
Information About Monitoring PPPoE Sessions with SNMP	256
Network Management Protocol	256
PPPoE Session Count MIB	256
Benefits of Monitoring PPPoE Sessions with SNMP	257
How to Configure Monitoring of PPPoE Sessions with SNMP	258
Configuring the PPPoE Session-Count Threshold for the Router	258
Configuring the PPPoE Session-Count Threshold for a PVC	259
Configuring the PPPoE Session-Count Threshold for a VC Class	261
Configuring the PPPoE Session-Count Threshold for an ATM PVC Range	263
Configuring the PPPoE Session-Count Threshold for an Individual PVC Within a Range	264
Monitoring and Maintaining PPPoE Session Counts and SNMP Notifications	266
Configuration Examples for Monitoring PPPoE Sessions with SNMP	269
Example: Configuring PPPoE Session-Count SNMP Traps	269
Example: Configuring PPPoE Session-Count Threshold for the Router	269

Example: Configuring PPPoE Session-Count Threshold for a PVC	269
Example: Configuring PPPoE Session-Count Threshold for a VC Class	269
Example: Configuring PPPoE Session-Count Threshold for a PVC Range	270
PPPoE Session-Count Threshold for an Individual PVC Within a PVC Range Example	270
Where to Go Next	270
Additional References	270
Feature Information for Monitoring PPPoE Sessions with SNMP	272

CHAPTER 24**PPPoE on ATM 275**

Finding Feature Information	275
Prerequisites for PPPoE on ATM	275
Restrictions for PPPoE on ATM	276
Information About PPPoE on ATM	276
PPPoE Stage Protocols	277
Benefits of PPPoE on ATM	277
How to Configure PPPoE on ATM	278
Enabling PPP over ATM	278
Creating and Configuring a Virtual Template	281
Specifying an ATM Subinterface	281
Creating an ATM PVC	282
Enabling PPPoE on an ATM PVC	282
Configuration Examples for PPPoE on ATM	283
PPPoE on ATM Example	283
Where to Go Next	284
Additional References	284
Feature Information for PPPoE on ATM	286
Glossary	286

CHAPTER 25**PPPoE on Ethernet 289**

Finding Feature Information	289
Prerequisites for PPPoE on Ethernet	289
Restrictions for PPPoE on Ethernet	290
Information About PPPoE on Ethernet	290
Benefits of Using PPPoE on Ethernet	290
How to Enable and Configure PPPoE on Ethernet	290

Enabling PPPoE on Ethernet in a VPDN Group	290
Limiting PPPoE Sessions from a MAC Address	291
Creating and Configuring a Virtual Template	291
Specifying an Ethernet Interface	292
Enabling PPPoE on an Ethernet Interface	292
Monitoring and Maintaining VPDN Groups	293
Configuration Examples for PPPoE on Ethernet	293
PPPoE on Ethernet Example	293
Enabling PPPoE on an Ethernet Interface Example	293
Additional References	294
Feature Information for PPPoE on Ethernet	295

CHAPTER 26**PPPoE over VLAN Enhancements Configuration Limit Removal and ATM Support 297**

Finding Feature Information	297
Restrictions for PPPoE over VLAN Enhancements Configuration Limit Removal and ATM Support	298
Information About PPPoE over VLAN Configuration Limit Removal and ATM Support	298
PPPoE over VLAN Configuration Without Using Subinterfaces	298
PPPoE over VLAN Support on ATM PVCs	298
Benefits of PPPoE over VLAN Enhancements Configuration Limit Removal and ATM Support	299
How to Configure PPPoE over VLAN Enhancements Configuration Limit Removal and ATM Support	300
Configuring PPPoE over IEEE 802.1Q VLAN Support on an Ethernet Interface	300
Configuring an ATM PVC to Support PPPoE over IEEE 802.1Q VLAN Traffic	301
Configuring a VC Class for PPPoE over IEEE 802.1Q VLAN Support	302
Monitoring and Maintaining PPPoE over IEEE 802.1Q VLAN	303
Configuration Examples for PPPoE over VLAN Enhancements Configuration Limit Removal and ATM Support	304
Configuring PPPoE over IEEE 802.1Q VLAN Support on an Ethernet Interface Example	304
Configuring PPPoE over IEEE 802.1Q VLAN Support on ATM PVCs Example	304
Additional References	305
Related Documents	305
Feature Information for PPPoE over VLAN Enhancements Configuration Limit Removal and ATM Support	306

CHAPTER 27**Configuring PPPoE over L2TPv3 Tunnels 309**

Information About Configuring PPPoE over L2TPv3 Tunnels 309

Overview of PPPoE over L2TPv3 Tunnels 309

Overview of PPPoE over L2TPv3 Tunnels—Example Topology 310

Benefits of PPPoE over L2TPv3 Tunneling 312

Prerequisites for PPPoE over L2TPv3 Tunnels 312

Restrictions for Configuring PPPoE over L2TPv3 Tunnels 312

Scaling of L2TPv3 Tunnels 313

Call Flows for PPPoE over L2TPv3/IPv6 Tunnels 314

NAS-Port-Type Extensions 314

Network Topology Overview 315

How to Configure PPPoE over L2TPv3 Tunnels 315

Overview of Configuring PPPoE over L2TPv3 Tunnels 315

Configuring the Edge Router for PPPoE over L2TPv3 Tunneling 316

Configuring the vSwitch 318

Verifying the vSwitch 321

Configuring Radius Authentication for PPPoE over L2TPv3 Tunnels 323

Configuring Radius Authentication for a PPP PTA Session 323

Configuring Radius Authentication for a PPP LAC Session 323

Configuring vBNG on the Cisco CSR 1000v VM 323

Configuring PPPoE over an L2TPv3 Tunnel on the Cisco CSR 1000v 325

Verifying PPPoE Sessions 326

Verifying PPPoE over L2TPv3 Tunnels 329

Troubleshooting PPPoE over L2TPv3 Tunnels 333

Additional References for Configuring PPPoE over L2TPv3 Tunnels 333

Feature Information for Configuring PPPoE over L2TPv3 Tunnels 334

CHAPTER 28**ADSL Support in IPv6 337**

Finding Feature Information 337

Restrictions for ADSL Support in IPv6 337

ADSL Support in IPv6 338

Address Assignment for IPv6 338

Stateless Address Autoconfiguration 338

How to Configure ADSL Support in IPv6 339

Configuring the NAS	339
Configuring the Remote CE Router	342
Configuration Examples for ADSL Support in IPv6	344
Example: NAS Configuration	344
Example: Remote CE Router Configuration	344
Additional References	344
Feature Information for ADSL Support in IPv6	345

CHAPTER 29

Broadband IPv6 Counter Support at LNS	347
Finding Feature Information	347
Information About Broadband IPv6 Counter Support at LNS	347
Broadband IPv6 Counter Support at LNS	347
How to Verify Broadband IPv6 Counter Support at LNS	348
Verifying Broadband IPv6 Counter Support at the LNS	348
Configuration Examples for Broadband IPv6 Counter Support at LNS	350
Examples: Verifying Broadband IPv6 Counter Support at the LNS	350
Example: show l2tp session Command	350
Example: show l2tp tunnel Command	350
Example: show l2tun session Command	350
Example: show vpdn session Command	350
Example: show vpdn tunnel Command	351
Additional References	351
Feature Information for Broadband IPv6 Counter Support at LNS	352

CHAPTER 30

PPP IP Unique Address and Prefix Detection	353
Finding Feature Information	353
Information About PPP IP Unique Address and Prefix Detection	353
How to Configure PPP IP Unique Address and Prefix Detection	354
Configuration Examples for PPP IP Unique Address and Prefix Detection	355
Example PPP Unique Address and Prefix Detection	355
Additional References	356
Feature Information for PPP IP Unique Address and Prefix Detection	357

CHAPTER 31

PPP IPv4 Address Conservation in Dual Stack Environments	359
Finding Feature Information	359

Prerequisites for PPP IPv4 Address Conservation in Dual Stack Environments	360
Restrictions for PPP IPv4 Address Conservation in Dual Stack Environments	360
Information About PPP IPv4 Address Conservation in Dual Stack Environments	360
IPv4 Address Conservation in Dual Stack Environments	360
PPP IP Unique Address and Prefix Detection	361
PPP Local NCP Override	361
AAA Delayed Accounting	361
How to Configure IPv4 Address Conservation in Dual Stack Environments	362
Configuring PPP IPv4 Address Conservation in Dual Stack Environments	362
Configuration Examples for PPP IPv4 Address Conservation in Dual Stack Environments	363
Example: PPP IPv4 Address Conservation in Dual Stack Environments	363
Additional References	363
Feature Information for PPP IPv4 Address Conservation in Dual Stack Environments	364

CHAPTER 32**TR-069 Agent 365**

Finding Feature Information	365
Limitations for the TR-069 Agent	365
Prerequisites for the TR-069 Agent	367
Information About the TR-069 Agent	367
TR-069 Agent	367
HTTP Digest Authentication Support	370
HTTP Cookie Support Per RFC2965	370
Device Gateway Association and Port Mapping Support	370
Device Gateway Association	370
Port Mapping Support	372
How to Configure and Enable the TR-069 Agent	373
Setting Up the CPE to Communicate with the ACS	373
Enabling the TR-069 Agent on the CPE	377
Initiating a TR-069 Agent Session from the ACS	378
Configuring HTTP Digest Authentication Support	379
Troubleshooting Tips	380
Clearing the HTTP Cookies	380
Troubleshooting Tips	380
Monitoring and Troubleshooting the HTTP Cookies	381
Configuration Examples for TR-069 Agent	381

Example: Setting Up the CPE to Communicate with the ACS	381
Example: Configuring and Enabling CWMP using the Autoinstall feature	382
Additional References for TR-069 Agent	382
Feature Information for TR-069 Agent	383
Glossary	384

CHAPTER 33**Broadband High Availability Stateful Switchover 385**

Finding Feature Information	385
Prerequisites for Broadband High Availability Stateful Switchover	386
Restrictions for Broadband High Availability Stateful Switchover	386
Information About Broadband High Availability Stateful Switchover	386
Feature Design of Broadband High Availability Stateful Switchover	386
Supported Broadband Aggregation Protocols	387
SSO PPPoA	387
SSO L2TP	387
SSO PPPoE	387
SSO RA-MLPS VPN	387
Benefits of Broadband High Availability Stateful Switchover	388
How to Configure Broadband High Availability Stateful Switchover	389
Configuring Subscriber Redundancy Policy for Broadband HA Stateful Switchover	389
Verifying and Troubleshooting Subscriber Redundancy Policy for Broadband HA Stateful Switchover	390
Configuration Examples for Broadband High Availability Stateful Switchover	396
Example Configuring Broadband High Availability Stateful Switchover	396
Additional References	400
Feature Information for Broadband High Availability Stateful Switchover	401

CHAPTER 34**Broadband High Availability In-Service Software Upgrade 403**

Finding Feature Information	403
Prerequisites for Broadband High Availability In-Service Software Upgrade	404
Restrictions for Broadband High Availability In-Service Software Upgrade	404
Information About Broadband High Availability In-Service Software Upgrade	404
Feature Design of Broadband High Availability In-Service Software Upgrade	404
Performing an ISSU	405
Supported Broadband Aggregation Protocols	405

ISSU PPPoA	405
ISSU L2TP	405
ISSU PPPoE	405
ISSU RA-MLPS VPN	405
Benefits of Broadband High Availability In-Service Software Upgrade	406
How to Configure Broadband High Availability In-Service Software Upgrade	407
Configuring Subscriber Redundancy Policy for Broadband High Availability In-Service Software Upgrade	407
Verifying and Troubleshooting Subscriber Redundancy Policy for Broadband HA ISSU	408
Configuration Examples for Broadband High Availability In-Service Software Upgrade	413
Example Subscriber Redundancy Policy for Broadband High Availability In-Service Software Upgrade	413
Additional References	417
Feature Information for Broadband High Availability In-Service Software Upgrade	419

CHAPTER 35

Controlling Subscriber Bandwidth	421
Finding Feature Information	421
Prerequisites for Controlling Subscriber Bandwidth	421
Restrictions for Controlling Subscriber Bandwidth	422
Information About Controlling Subscriber Bandwidth	422
Traffic-Shaping Parameters	422
Benefits of Controlling Subscriber Bandwidth	423
How to Control Subscriber Bandwidth	423
Configuring DBS Under a VC Class	423
Configuring DBS on a PVC	424
Configuring DBS on a Range of PVCs	425
Configuring DBS on a PVC Within a PVC Range	426
Configuring the RADIUS Attributes for DBS	427
Verifying DBS	428
Monitoring DBS	432
Configuration Examples for Controlling Subscriber Bandwidth	433
Configuring DBS for a VC Class Example	433
Configuring DBS for a PVC Example	433
Configuring DBS for a Range of PVCs Example	433

Configuring DBS for a PVC Within a PVC Range Example	434
Configuring RADIUS Attributes Examples	434
Additional References	434
Feature Information for Controlling Subscriber Bandwidth	436

CHAPTER 36**PPPoE Service Selection 437**

Finding Feature Information	437
Prerequisites for PPPoE Service Selection	437
Information About PPPoE Service Selection	438
PPPoE Service Selection Through Service Tags	438
PPPoE Service Names	438
RADIUS Service Profiles for PPPoE Service Selection	439
Benefits of PPPoE Service Selection	439
Attributes Used to Define a RADIUS Service Profile for PPPoE Selection	439
Attributes Used to Configure a Subscriber Profile on the RADIUS Server for PPPoE Service Selection	440
How to Offer PPPoE Service Selection	441
Configuring the Subscriber Profile for PPPoE Service Selection	441
Configuring the PPPoE Profile for PPPoE Service Selection	442
Troubleshooting Tips	444
What to Do Next	444
Configuring Service Names for PPPoE Clients on an ATM PVC	444
Verifying PPPoE Service Selection	446
Monitoring and Maintaining PPPoE Service Selection	447
Configuration Examples for PPPoE Service Selection	451
Example PPPoE Service Selection with ATM QoS and Tunneling Services	451
Example PPPoE Service Selection with Tunneling Services	452
Where to Go Next	453
Additional References	454
Feature Information for PPPoE Service Selection	455

CHAPTER 37**Disabling AC-name and AC-cookie Tags from PPPoE PADS 457**

Finding Feature Information	457
Restrictions for Disabling AC-name and AC-cookie Tags from PPPoE PADS	457
Information About Disabling AC-name and AC-cookie Tags from PPPoE PADS	458

How to Disable AC-name and AC-cookie Tags from PPPoE PADS	458
Disabling AC-name and AC-cookie Tags from PPPoE PADS	458
Verifying Disabling AC-name and AC-cookie Tags from PPPoE PADS	459
Configuration Example for Disabling AC-name and AC-cookie Tags from PPPoE PADS	460
Example: Disabling AC-name and AC-cookie Tags from PPPoE PADS	460
Additional References for Disabling AC-name and AC-cookie Tags from PPPoE PADS	460
Feature Information for Disabling AC-name and AC-cookie Tags from PPPoE PADS	461

CHAPTER 38

Broadband Smart Licensing	463
Finding Feature Information	463
Prerequisites for Broadband Smart Licensing	463
Restrictions for Broadband Smart Licensing	464
Information About Broadband Smart Licensing	464
Broadband Sessions	464
How to Configure Broadband Smart Licensing	464
Configuring the Subscriber License	464
Clearing the Subscriber License	465
Verifying Broadband Smart Licensing	466
Configuration Examples for Broadband Smart Licensing	466
Example: show subscriber license	466
Example: Show license summary	467
Example: Clear subscriber license	467
Additional References for Broadband Smart Licensing	467
Feature Information for Broadband Smart Licensing	468



Read Me First

Important Information about Cisco IOS XE 16

Effective Cisco IOS XE Release 3.7.0E (for Catalyst Switching) and Cisco IOS XE Release 3.17S (for Access and Edge Routing) the two releases evolve (merge) into a single version of converged release—the Cisco IOS XE 16—providing one release covering the extensive range of access and edge products in the Switching and Routing portfolio.

Feature Information

Use [Cisco Feature Navigator](#) to find information about feature support, platform support, and Cisco software image support. An account on Cisco.com is not required.

Related References

- [Cisco IOS Command References, All Releases](#)

Obtaining Documentation and Submitting a Service Request

For information on obtaining documentation, using the Cisco Bug Search Tool (BST), submitting a service request, and gathering additional information, see [What's New in Cisco Product Documentation](#).

To receive new and revised Cisco technical content directly to your desktop, you can subscribe to the [What's New in Cisco Product Documentation RSS feed](#). RSS feeds are a free service.



CHAPTER 2

Preparing for Broadband Access Aggregation

Before you begin to perform the tasks required to accomplish broadband access aggregation, there are several preparatory tasks that you can perform at your option to enable you to complete the aggregation task with more efficiency. This module presents three of those preparation tasks: configuring permanent virtual circuits (PVCs), configuring a virtual template interface, and configuring enhancements for broadband scalability.

In a digital subscriber line (DSL) environment, many applications require the configuration of a large number of PVCs. Configuring PVCs before you start broadband aggregation can save you time because configuring a range of PVCs is faster than configuring PVCs individually.

A virtual template interface saves time because all PPP parameters are managed within the virtual template configuration. Any configurations made in the virtual template are automatically propagated to the individual virtual access interfaces.

Using the enhancement for broadband scalability reduces the amount of memory that is used per terminated PPP session by creating virtual access subinterfaces. Determining if virtual access subinterfaces are available on your system and preconfiguring these enhancements can speed your aggregation process and improve system performance.

- [Finding Feature Information, page 3](#)
- [Prerequisites for Preparing for Broadband Access Aggregation, page 4](#)
- [Restrictions for Preparing for Broadband Access Aggregation, page 4](#)
- [Information About Preparing for Broadband Access Aggregation, page 4](#)
- [How to Prepare for Broadband Access Aggregation, page 6](#)
- [Configuration Examples for Preparing for Broadband Access Aggregation, page 8](#)
- [Additional References, page 10](#)
- [Feature Information for Preparing for Broadband Access Aggregation, page 12](#)

Finding Feature Information

Your software release may not support all the features documented in this module. For the latest caveats and feature information, see [Bug Search Tool](#) and the release notes for your platform and software release. To find information about the features documented in this module, and to see a list of the releases in which each feature is supported, see the feature information table.

Use Cisco Feature Navigator to find information about platform support and Cisco software image support. To access Cisco Feature Navigator, go to www.cisco.com/go/cfn. An account on Cisco.com is not required.

Prerequisites for Preparing for Broadband Access Aggregation

Before configuring broadband access aggregation, you will need to know the information that is presented in the "Understanding Broadband Access Aggregation" module.

Additional information can be found in these documents:

- Configuring a PVC range--For detailed information about configuring individual ATM PVCs, see "Configuring PVCs" in the Cisco IOS Wide-Area Networking Configuration Guide.
- Creating a virtual template--For detailed information see the "Configuring Virtual Template Interfaces" chapter in the Cisco IOS Dial Technologies Configuration Guide.

Restrictions for Preparing for Broadband Access Aggregation

- Due to high scaling requirements, only virtual access subinterfaces are supported. Disabling virtual access subinterfaces is not supported.
- Precloning virtual access interfaces is not supported.
- When an interface has large number of subinterfaces disabled, the interface's Remote Access (RA) messages that have a lifetime value of zero are not sent to all its subinterfaces.

Information About Preparing for Broadband Access Aggregation

Virtual Access Interfaces

A virtual template interface is used to provide the configuration for dynamically created virtual access interfaces. It is created by users and can be saved in NVRAM.

Once the virtual template interface is created, it can be configured in the same way as a serial interface.

Virtual template interfaces can be created and applied by various applications such as virtual profiles, virtual private dialup networks (VPDNs), and protocol translation.

All PPP parameters are managed within the virtual template configuration. Configuration changes made to the virtual template are automatically propagated to the individual virtual access interfaces. Multiple virtual access interfaces can originate from a single virtual template.

Cisco IOS XE software supports up to 4096 virtual template configurations. If greater numbers of tailored configurations are required, an authentication, authorization, and accounting (AAA) server can be used.

If the parameters of the virtual template are not explicitly defined before the interface is configured, the PPP interface is brought up using default values from the virtual template. Some parameters (such as an IP address) take effect only if specified before the PPP interface comes up. Therefore, it is recommended that you explicitly create and configure the virtual template before configuring the interface to ensure that such parameters take effect. Alternatively, if parameters are specified after the interface has been configured, use the **shutdown**

command followed by the **no shutdown** command on the subinterface to restart the interface; this restart will cause the newly configured parameters (such as an IP address) to take effect.

Configuration Enhancements for Broadband Scalability

The Configuration Enhancements for Broadband Scalability feature reduces the amount of memory that is used per terminated PPP session by creating virtual-access subinterfaces. Depending on the configuration of the source virtual template, virtual-access subinterfaces may be available. This feature also introduces a command to determine if a virtual template is compatible with virtual access subinterfaces.

Virtual Access Subinterfaces

The **virtual-template** command supports existing features, functions, and configurations. By default, the **virtual-template subinterface** command is enabled; this command cannot be disabled.

The virtual template manager will determine if the set of options configured on the virtual template are all supported on a subinterface. Virtual access subinterfaces will be created for all virtual templates that support subinterfaces. If the user has entered any commands that are not supported on a subinterface, a full virtual access interface is created and cloned for all PPP sessions using that virtual template.

Different applications can use the same virtual template even if one application is subinterface-capable and another is not. The virtual template manager is notified whether the application supports virtual access subinterfaces and creates the appropriate resource.

Virtual Template Compatibility with Subinterfaces

The **test virtual-template subinterface** privileged EXEC command determines whether a virtual template can support the creation of a virtual access subinterface. If the virtual template contains commands that prevent the creation of subinterfaces, the **test virtual-template subinterface** command identifies and displays these commands.

The **debug vtemplate subinterface** command displays debug messages that are generated if you enter configuration commands on the virtual template that are not valid on a subinterface. These messages are generated only if the **debug vtemplate subinterface** command is enabled, the **virtual-template subinterface command** is enabled, and a virtual template is configured that can support the creation of subinterfaces. If the creation of virtual access subinterfaces is disabled by the **no virtual-template** subinterface command, the **debug vtemplate subinterface** command produces no output.

Benefits of Broadband Scalability Features

Using broadband scalability reduces the amount of memory that is used per terminated PPP session by creating virtual access subinterfaces. These virtual access subinterfaces, along with improvements that are transparent to the user, speed up the cloning process.

How to Prepare for Broadband Access Aggregation

Configuring a Virtual Template Interface

Configure a virtual template interface before you configure PPPoE on an Ethernet interface. The virtual template interface is a logical entity that is applied dynamically as needed to an incoming PPP session request. Perform this task to create and configure a virtual template interface:

SUMMARY STEPS

1. **enable**
2. **configure terminal**
3. **Interface virtual-template** *number* [type [ethernet | serial | tunnel]]
4. **ip unnumbered ethernet** *number*
5. **mtu** *bytes*
6. **ppp authentication chap**
7. **ppp ipcp ip address required**
8. **end**

DETAILED STEPS

	Command or Action	Purpose
Step 1	enable Example: Router> enable	Enables privileged EXEC mode. <ul style="list-style-type: none"> • Enter your password if prompted.
Step 2	configure terminal Example: Router# configure terminal	Enters global configuration mode.
Step 3	Interface virtual-template <i>number</i> [type [ethernet serial tunnel]] Example: Router(config)# interface virtual-template 1	Creates a virtual template interface and enters interface configuration mode.
Step 4	ip unnumbered ethernet <i>number</i> Example: Router(config-if)# ip unnumbered ethernet 3/1	Enables IP without assigning a specific IP address on the LAN.

	Command or Action	Purpose
Step 5	mtu bytes Example: Router(config-if)# mtu bytes	(Optional) Sets the maximum MTU size for the interface. <ul style="list-style-type: none"> Valid range for the MTU size is 1492 or 1500.
Step 6	ppp authentication chap Example: Router(config-if)# ppp authentication chap	Enables PPP authentication on the virtual template interface.
Step 7	ppp ipcp ip address required Example: Router(config-if)# ppp ipcp ip address required	Prevents a PPP session from being set up without a valid address being negotiated. This command is required for legacy dialup and DSL networks.
Step 8	end Example: Router(config-if)# end	Exits interface configuration mode.

Examples

The following example shows the configuration of a virtual template interface:

```
Router(config)# interface virtual-template 1
Router(config)# ip unnumbered21 Loopback1
Router(config-if)# no peer default ip address
Router(config-if)# ppp authentication chap
Router(config-if)# ppp authorization
Router(config-if)# ppp accounting
```

Configuring Enhancements for Broadband Scalability

To configure enhancement for broadband scalability, you will perform the following task:

Verifying Virtual Template Compatibility with Virtual Access Subinterfaces

Perform the following task to test a virtual template to determine if it is compatible with the creation of virtual access subinterfaces.

SUMMARY STEPS

1. **enable**
2. **test virtual-template *template* subinterface**

DETAILED STEPS

	Command or Action	Purpose
Step 1	enable Example: Router> enable	Enables privileged EXEC mode. <ul style="list-style-type: none"> • Enter your password if prompted.
Step 2	test virtual-template <i>template</i> subinterface Example: Router# test virtual-template virtual-templatel subinterface	Tests the specified virtual template to determine if it is compatible with the creation of virtual access subinterfaces.

Examples

The output generated by the **test virtual-template subinterface** command describes the compatibility of the virtual template with the creation of subinterfaces.

This example shows output indicating that the virtual template is not compatible. This output also includes a list of the commands, which are configured on the virtual template, that cause the incompatibility.

```
Router# test virtual-template virtual-templatel subinterface
```

```
Subinterfaces cannot be created using
Virtual-Templatel
Interface commands:
traffic-shape rate 50000 8000 8000 1000
```

Configuration Examples for Preparing for Broadband Access Aggregation

Virtual Access Subinterfaces Configuration Examples

This section provides the following configuration examples:

Virtual Access Subinterface Configuration Example

The example that follows shows a virtual template that is compatible with virtual access subinterfaces:



Note

The **virtual-access subinterface** command is enabled by default and does not appear in running configurations. Only the **no virtual-access subinterface** command will appear in running configurations.

```
interface Virtual-Template1
 ip unnumbered Loopback0
 peer default ip address pool pool-1
 ppp authentication chap
 ppp multilink
```

The following example shows a configuration in which the creation of virtual access subinterfaces has been disabled by the **no virtual-access subinterface** command. When this command is configured, virtual access interfaces are not registered with the SNMP code on the router. In network environments that do not use SNMP to manage PPP sessions, this saves the memory and CPU processing that would be used to register the virtual access interfaces with the SNMP code.

```
Current configuration :6003 bytes
!
! Last configuration change at 10:59:02 EDT Thu Sep 19 2004
!
version 12.2
service timestamps debug datetime msec
service timestamps log datetime msec
no service password-encryption
service internal
service udp-small-servers
service tcp-small-servers
!
hostname ioswan5-lns
!
enable password lab
!
username cisco password 0 cisco
clock timezone EST -5
clock summer-time EDT recurring
aaa new-model
!
!
aaa authentication ppp default local
aaa authorization network default local
aaa session-id common
ip subnet-zero
no ip gratuitous-arps
ip cef
!
!
no ip domain lookup
ip name-server 10.44.11.21
ip name-server 10.44.11.206
!
ip vrf vpn1
rd 10:1
route-target export 10:1
route-target import 10:1
!
vpdn enable
!
vpdn-group 1
accept-dialin
protocol l2tp
virtual-template 1
```

```

terminate-from hostname ioswan5-lac
local name tunnell
l2tp tunnel password 7 01100F175804
!
!

!
no virtual-template subinterface
no virtual-template snmp
virtual-template 1 pre-clone 10
!
!
!
buffers small permanent 20000
buffers middle permanent 7500
!
!
!
interface Loopback1
ip address 10.111.1.1 255.255.255.0

```

Testing a Virtual Template for Compatibility with Subinterfaces Example

This example shows the process for testing a virtual template to determine if it can support virtual access subinterfaces. The following command displays the configuration for virtual template 1:

```

Router# show running interface virtual-template 1
Building configuration...
!
interface Virtual-Template1
ip unnumbered Loopback0
peer default ip address pool pool-1
ppp authentication chap
traffic-shape rate 50000 8000 8000 1000
end

```

The **test virtual-template subinterface** command tests virtual template 1 to determine if it can support subinterfaces. The output shows that the **traffic-shape rate** command that is configured on virtual template 1 prevents the virtual template from being able to support subinterfaces.

```

Router# test virtual-template 1 subinterface
Subinterfaces cannot be created using Virtual-Template1
Interface commands:
traffic-shape rate 50000 8000 8000 1000

```

Additional References

The following sections provide references related to preparing for broadband access aggregation.

Related Documents

Related Topic	Document Title
Broadband access aggregation of PPPoE Sessions	Providing Protocol Support for Broadband Access Aggregation of PPPoE Sessions
Specifying a range for the ppp-max payload tag value	PPP-Max-Payload and IWF PPPoE Tag Support

Related Topic	Document Title
Additional information about commands used in this document	<ul style="list-style-type: none"> • <i>Cisco IOS Broadband Access Aggregation and DSL Command Reference</i> • Cisco IOS Master Command List, All Releases

Standards

Standards	Title
No new or modified standards are supported by this feature, and support for existing standards has not been modified by this feature.	--

MIBs

MIBs	MIBs Link
No new or modified MIBs are supported by this feature, and support for existing MIBs has not been modified by this feature.	To locate and download MIBs for selected platforms, Cisco IOS XE releases, and feature sets, use Cisco MIB Locator found at the following URL: http://www.cisco.com/go/mibs

RFCs

RFCs	Title
No new or modified RFCs are supported by this feature, and support for existing RFCs has not been modified by this feature.	--

Technical Assistance

Description	Link
<p>The Cisco Support website provides extensive online resources, including documentation and tools for troubleshooting and resolving technical issues with Cisco products and technologies.</p> <p>To receive security and technical information about your products, you can subscribe to various services, such as the Product Alert Tool (accessed from Field Notices), the Cisco Technical Services Newsletter, and Really Simple Syndication (RSS) Feeds.</p> <p>Access to most tools on the Cisco Support website requires a Cisco.com user ID and password.</p>	<p>http://www.cisco.com/techsupport</p>

Feature Information for Preparing for Broadband Access Aggregation

The following table provides release information about the feature or features described in this module. This table lists only the software release that introduced support for a given feature in a given software release train. Unless noted otherwise, subsequent releases of that software release train also support that feature.

Use Cisco Feature Navigator to find information about platform support and Cisco software image support. To access Cisco Feature Navigator, go to www.cisco.com/go/cfn. An account on Cisco.com is not required.

Table 1: Feature Information for Preparing for Broadband Aggregation

Feature Name	Software Releases	Feature Configuration Information
Virtual Sub-Interface--Configuration Enhancements for Broadband Scalability	Cisco IOS XE Release 2.1	<p>This feature was introduced on Cisco ASR 1000 Series Routers.</p> <p>This feature reduces the amount of memory that is used per terminated PPP session by creating virtual access subinterfaces. Depending on the configuration of the source virtual template, virtual access subinterface may be available. This feature also introduces a command to determine if a virtual template is compatible with virtual access subinterfaces.</p>



Providing Protocol Support for Broadband Access Aggregation of PPPoE Sessions

PPP over Ethernet profiles contain configuration information for a group of PPP over Ethernet (PPPoE) sessions. Multiple PPPoE profiles can be defined for a device, allowing different virtual templates and other PPPoE configuration parameters to be assigned to different PPP interfaces, VLANs, and ATM permanent virtual circuits (PVCs) that are used in supporting broadband access aggregation of PPPoE sessions.



Note

This module describes the method for configuring PPPoE sessions using profiles.

- [Finding Feature Information](#), page 13
- [Prerequisites for Providing Protocol Support for Broadband Access Aggregation of PPPoE Sessions](#), page 14
- [Restrictions for Providing Protocol Support for Broadband Access Aggregation of PPPoE Sessions](#), page 14
- [Information About Providing Protocol Support for Broadband Access Aggregation for PPPoE Sessions](#), page 15
- [How to Provide Protocol Support for Broadband Access Aggregation of PPPoE Sessions](#), page 17
- [Configuration Examples for Providing Protocol Support for Broadband Access Aggregation of PPPoE Sessions](#), page 30
- [Where to Go Next](#), page 34
- [Additional References](#), page 34
- [Feature Information for Providing Protocol Support for Broadband Access Aggregation of PPPoE Sessions](#), page 36

Finding Feature Information

Your software release may not support all the features documented in this module. For the latest caveats and feature information, see [Bug Search Tool](#) and the release notes for your platform and software release. To

find information about the features documented in this module, and to see a list of the releases in which each feature is supported, see the feature information table.

Use Cisco Feature Navigator to find information about platform support and Cisco software image support. To access Cisco Feature Navigator, go to www.cisco.com/go/cfn. An account on Cisco.com is not required.

Prerequisites for Providing Protocol Support for Broadband Access Aggregation of PPPoE Sessions

- You must understand the concepts described in the Understanding Broadband Access Aggregation module.
- You must perform the tasks contained in the Preparing for Broadband Access Aggregation module.

Restrictions for Providing Protocol Support for Broadband Access Aggregation of PPPoE Sessions

If a PPPoE profile is assigned to a PPPoE port (Gigabit Ethernet interface or PVC), virtual circuit (VC) class, or ATM PVC range and the profile has not yet been defined, the port, VC class, or range will not have any PPPoE parameters configured and will not use parameters from the global group.

The subscriber features that are supported/ not supported on PPP sessions are listed in the table below:

Table 2: Subscriber Features Supported and not Supported on PPP Sessions

Feature Name	Support Release
Per Subscriber Firewall on LNS	Cisco IOS XE Release 2.2.1. Release Notes for Cisco ASR 1000 Series Aggregation Services Routers for Cisco IOS XE Release 2
Per Subscriber Firewall on PTA	Not supported
Per Subscriber NAT	Support PPPoE with Carrier Grade NAT (CGN) in Cisco IOS XE Release 3.6
Per Subscriber PBR	Supports up to 1000 sessions from Cisco IOS XE Release 3.1S
Per Subscriber NBAR	Not supported
Per Subscriber Multicast	Supports up to 3,000 sessions from Cisco IOS XE Release 2.2.1 Release Notes for Cisco ASR 1000 Series Aggregation Services Routers for Cisco IOS XE Release 2
Per Subscriber Netflow	Not supported
Per Subscriber QPPB	Not supported

Feature Name	Support Release
MLPPP on LNS, MLPoE on PTA, MLPoE LAC Switching	Supported. For more information see Configuring Multilink Point-to-Point Protocol Connections .
VLAN range	Not supported

Information About Providing Protocol Support for Broadband Access Aggregation for PPPoE Sessions

PPPoE Specification Definition

PPP over Ethernet (PPPoE) is a specification that defines how a host PC interacts with common broadband medium (for example, a digital subscriber line (DSL), wireless modem or cable modem) to achieve access to a high-speed data network. Relying on two widely accepted standards, Gigabit Ethernet and PPP, the PPPoE implementation allows users over the Gigabit Ethernet to share a common connection. The Gigabit Ethernet principles supporting multiple users in a LAN, combined with the principles of PPP, which apply to serial connections, support this connection.

The base protocol is defined in RFC 2516.

PPPoE Connection Throttling

Repeated requests to initiate PPPoE sessions can adversely affect the performance of a router and RADIUS server. The PPPoE Connection Throttling feature limits PPPoE connection requests to help prevent intentional denial-of-service attacks and unintentional PPP authentication loops. This feature implements session throttling on the PPPoE server to limit the number of PPPoE session requests that can be initiated from a MAC address or VC during a specified period of time.

PPPoE VLAN Session Throttling

This feature throttles the number of PPPoE over QinQ sessions over each subinterface. If the number of new incoming session requests on the subinterface, exceeds the configured incoming session setup rate, the new session requests will be rejected. You can enable this capability independently on each Gigabit Ethernet subinterface.

The number of incoming session requests will be calculated separately on a combination of each port and subinterface, independent of each other. For example, if there are 2 subinterfaces sharing the QinQ VLAN IDs, the session rate of each is calculated separately. You should assign the bba-group configuration on each subscriber subinterface, with an unambiguous VLAN or outer and inner VLAN IDs (in the case of QinQ).

Autosense for ATM PVCs

The PPPoA/PPPoE Autosense for ATM PVCs feature enables a router to distinguish between incoming PPP over Ethernet (PPPoE) over ATM sessions and to create virtual access based on demand for both PPP types.



Note

The PPPoA/PPPoE Autosense for ATM PVCs feature is supported on Subnetwork Access Protocol (SNAP)-encapsulated ATM PVCs only. It is not supported on multiplexer (MUX)-encapsulated PVCs.

Benefits of Autosense for ATM PVCs

Autosense for ATM PVCs provides resource allocation on demand. For each PVC configured for PPPoE, certain resources (including one virtual-access interface) are allocated upon configuration, regardless of the existence of a PPPoE session on that PVC. The autosense for ATM PVCs resources are allocated for PPPoE sessions only when a client initiates a session, thus reducing overhead on the NAS.



Note

Autosense for ATM PVCs supports ATM PVCs only. Switched virtual circuits (SVCs) are not supported.

MAC Address for PPPoEoA

To prevent customers from experiencing unexpected behavior resulting from a system change, any change in the usage of MAC addresses will not happen unless it is explicitly configured.

Except for using a different MAC address, this feature does not change the way PPPoE works. This change is limited to ATM interfaces only--specifically, PPPoEoA--and will not be applied to other interfaces where PPPoE is operated on interfaces such as Gigabit Ethernet, Ethernet VLAN, and Data-over-Cable Service Interface Specifications (DOCSIS). Changing the PPPoE MAC address on those interfaces, which are broadcast in nature, requires placing the interface in promiscuous mode, thereby affecting the performance of the router because the router software has to receive all Gigabit Ethernet frames and then discard unneeded frames in the software driver.

This feature is disabled by default and applies to all PPPoE sessions on an ATM PVC interface configured in a BBA group.

When PPPoE and Rapid Bandwidth Expansion (RBE) are configured on two separate PVCs on the same DSL, the customer premises equipment (CPE) acts like a pure bridge, bridging from Gigabit Ethernet to the two ATM PVCs on the DSL. Because the CPE acts as a bridge, and because the aggregation router uses the same MAC address for both PPPoE and RBE, the CPE will not be able to bridge packets to the correct PVC. The solution is to have a different MAC address for PPPoE only. The MAC address can be either configured or selected automatically.

The MAC address of the PPPoEoA session is either the value configured on the ATM interface using the **mac-address** command or the burned-in MAC address if a MAC address is not already configured on the ATM interface. This functionality is effective only when neither autoselect nor a MAC address is specified on a broadband access group (BBA) group.

If the MAC address is specified on a BBA group, all PPPoEoA sessions use the MAC address specified on the BBA group, which is applied on the VC.

If the MAC address is selected automatically, 7 is added to the MAC address of the ATM interface.

Benefits of the Configurable MAC Address for PPPoE Feature

Because the aggregation routers use the interface MAC address as the source MAC address for all broadband aggregation protocols on that interface, this feature solves problems that may occur when both RBE and PPPoE are deployed on the same ATM interface.

How to Provide Protocol Support for Broadband Access Aggregation of PPPoE Sessions

To provide protocol support for broadband access aggregation by assigning a profile, defining the profile is required.

When configuring a PPPoE session recovery after a system reload, perform the following task:

Defining a PPPoE Profile

Perform this task to define a PPPoE profile.

SUMMARY STEPS

1. **enable**
2. **configure terminal**
3. **bba-group pppoe** *{group-name | global}*
4. **virtual-template** *template-number*
5. **sessions max limit** *number-of-sessions* [**threshold** *threshold-value*]
6. **sessions per-mac limit** *per-mac-limit*
7. **sessions per-vlan limit** *per-vlan-limit* **inner** *per-inner-vlan-limit*
8. **sessions per-vc limit** *per-vc-limit* [**threshold** *threshold-value*]
9. **sessions** **{per-mac | per-vc | per-vlan}** **throttle** *session-requests session-request-period blocking-period*
10. **ac name** *name*
11. **end**

DETAILED STEPS

	Command or Action	Purpose
Step 1	enable Example: Router> enable	Enables privileged EXEC mode. <ul style="list-style-type: none"> • Enter your password if prompted.

	Command or Action	Purpose
Step 2	configure terminal Example: <pre>Router# configure terminal</pre>	Enters global configuration mode.
Step 3	bba-group pppoe <i>{group-name global}</i> Example: <pre>Router(config)# bba-group pppoe global</pre>	Defines a PPPoE profile, and enters BBA group configuration mode. <ul style="list-style-type: none"> The global keyword creates a profile that serves as the default profile for any PPPoE port that is not assigned a specific profile.
Step 4	virtual-template <i>template-number</i> Example: <pre>Router(config-bba-group)# virtual-template 1</pre>	Specifies which virtual template will be used to clone virtual access interfaces for all PPPoE ports that use this PPPoE profile.
Step 5	sessions max limit <i>number-of-sessions</i> [threshold <i>threshold-value</i>] Example: <pre>Router(config-bba-group)# sessions max limit 8000</pre>	Configures the PPPoE global profile with the maximum number of PPPoE sessions that will be permitted on a router and sets the PPPoE session-count threshold at which an Simple Network Management Protocol (SNMP) trap will be generated. <p>Note This command applies only to the global profile.</p>
Step 6	sessions per-mac limit <i>per-mac-limit</i> Example: <pre>Router(config-bba-group)# sessions per-mac limit 2</pre>	Sets the maximum number of PPPoE sessions permitted per MAC address in a PPPoE profile.
Step 7	sessions per-vlan limit <i>per-vlan-limit</i> inner <i>per-inner-vlan-limit</i> Example: <pre>Router(config-bba-group)# sessions per-vlan limit 200</pre>	Sets the maximum number of PPPoE sessions permitted per VLAN in a PPPoE profile. <ul style="list-style-type: none"> The inner keyword sets the number of sessions permitted per outer VLAN.
Step 8	sessions per-vc limit <i>per-vc-limit</i> [threshold <i>threshold-value</i>] Example: <pre>Router(config-bba-group)# sessions per-vc limit 8</pre>	Sets the maximum number of PPPoE sessions permitted on a VC in a PPPoE profile, and sets the PPPoE session-count threshold at which an SNMP trap will be generated.

	Command or Action	Purpose
Step 9	<p>sessions {per-mac per-vc per-vlan} throttle <i>session-requests session-request-period blocking-period</i></p> <p>Example:</p> <pre>Router(config-bba-group)# sessions per-vc throttle 100 30 3008</pre>	(Optional) Configures PPPoE connection throttling, which limits the number of PPPoE session requests that can be made from a VLAN, VC, or a MAC address within a specified period of time.
Step 10	<p>ac name <i>name</i></p> <p>Example:</p> <pre>Router(config-bba-group)# ac name acl</pre>	(Optional) Specifies the name of the access concentrator to be used in PPPoE active discovery offers (PADOs).
Step 11	<p>end</p> <p>Example:</p> <pre>Router(config-bba-group)# end</pre>	(Optional) Exits BBA group configuration mode and returns to privileged EXEC mode.

Enabling PPPoE on an Interface

SUMMARY STEPS

1. **enable**
2. **configure terminal**
3. **interface gigabitethernet** *number*
4. **encapsulation dot1q second-dot1q** {any | *vlan-id*}
5. **pppoe enable** [*group group-name*]
6. **end**

DETAILED STEPS

	Command or Action	Purpose
Step 1	<p>enable</p> <p>Example:</p> <pre>Router> enable</pre>	<p>Enables privileged EXEC mode.</p> <ul style="list-style-type: none"> • Enter your password if prompted.

	Command or Action	Purpose
Step 2	configure terminal Example: Router# configure terminal	Enters global configuration mode.
Step 3	interface gigabitethernet <i>number</i> Example: Router(config)# interface gigabitethernet 0/0/0.0	Specifies an Gigabit Ethernet interface and enters subinterface configuration mode.
Step 4	encapsulation dot1q second-dot1q {<i>any</i> <i>vlan-id</i>} Example: Router(config-subif)# encapsulation dot1q second-dot1q 1	Defines the matching criteria to map Q-in-Q ingress frames on an interface to the appropriate service instance.
Step 5	pppoe enable [<i>group group-name</i>] Example: Router(config-subif)# pppoe enable group one	Enables PPPoE sessions on an Gigabit Ethernet interface or subinterface. Note If a PPPoE profile is not assigned to the interface by using the group <i>group-name</i> option, the interface will use the global PPPoE profile.
Step 6	end Example: Router(config-subif)# end	(Optional) Exits subinterface configuration mode and returns to privileged EXEC mode.

Assigning a PPPoE Profile to an ATM PVC

Perform this task to assign a PPPoE profile to an ATM PVC.

SUMMARY STEPS

1. **enable**
2. **configure terminal**
3. **interface atm** *number* [**point-to-point** | **multipoint**]
4. **pvc** *vpi / vci*
5. Do one of the following:
 - **protocol pppoe** [**group** *group-name*]
 - or
 - **encapsulation aal5autoppp virtual-template** *number* [**group** *group-name*]
6. **end**

DETAILED STEPS

	Command or Action	Purpose
Step 1	enable Example: Device> enable	Enables privileged EXEC mode. • Enter your password if prompted.
Step 2	configure terminal Example: Device# configure terminal	Enters global configuration mode.
Step 3	interface atm <i>number</i> [point-to-point multipoint] Example: Device(config)# interface atm 5/0.1 multipoint	Specifies an ATM interface or subinterface and enters interface configuration mode.
Step 4	pvc <i>vpi / vci</i> Example: Device(config-if)# pvc 2/101	Creates an ATM PVC and enters ATM virtual circuit configuration mode.
Step 5	Do one of the following: • protocol pppoe [group <i>group-name</i>] • or • encapsulation aal5autoppp virtual-template <i>number</i> [group <i>group-name</i>]	Enables PPPoE sessions to be established on ATM PVCs. or Configures PPPoE autosense on the PVC. Note If a PPPoE profile is not assigned to the PVC by using the group <i>group-name</i> option, the PVC will use the global PPPoE profile.

	Command or Action	Purpose
	<p>Example:</p> <pre>Device(config-if-atm-vc)# protocol pppoe group one</pre> <p>Example:</p> <pre>or</pre> <p>Example:</p> <pre>Device(config-if-atm-vc)# encapsulation aal5autopp virtual-template 1 group one</pre>	
Step 6	<p>end</p> <p>Example:</p> <pre>Device(config-if-atm-vc)# end</pre>	(Optional) Exits ATM virtual circuit configuration mode and returns to privileged EXEC mode.

Assigning a PPPoE Profile to an ATM PVC Range and PVC Within a Range

Perform this task to assign a PPPoE profile to an ATM PVC range and PVC within a range.

SUMMARY STEPS

1. **enable**
2. **configure terminal**
3. **interface atm** *number* [**point-to-point** | **multipoint**]
4. **range** [*range-name*] **pvc** *start-vpi / start-vci end-vpi / end-vci*
5. **protocol pppoe** [**group** *group-name*]
6. **pvc-in-range** [*pvc-name*] [[*vpi /vci*]
7. Do one of the following:
 - **protocol pppoe** [**group** *group-name*]
 - or
 - **encapsulation aal5autopp virtual-template** *number* [**group** *group-name*]
8. **end**

DETAILED STEPS

	Command or Action	Purpose
Step 1	enable Example: Device> enable	Enables privileged EXEC mode. <ul style="list-style-type: none"> • Enter your password if prompted.
Step 2	configure terminal Example: Device# configure terminal	Enters global configuration mode.
Step 3	interface atm <i>number</i> [point-to-point multipoint] Example: Device(config)# interface atm 5/1 multipoint	Specifies an ATM interface and enters interface configuration mode.
Step 4	range [<i>range-name</i>] pvc <i>start-vpi</i> / <i>start-vci</i> <i>end-vpi</i> / <i>end-vci</i> Example: Device(config-if)# range range-one pvc 100 4/199	Defines a range of PVCs and enters ATM PVC range configuration mode.
Step 5	protocol pppoe [group <i>group-name</i>] Example: or Example: encapsulation aal5autopp virtual-template <i>number</i> [group <i>group-name</i>] Example: Device(config-if-atm-range)# protocol pppoe group one or Example: Device(config-if-atm-range)# encapsulation aal5autopp virtual-template 1 group one	Enables PPPoE sessions to be established on a range of ATM PVCs. or Configures PPPoE autosense. Note If a PPPoE profile is not assigned to the PVC range by using the group <i>group-name</i> option, the PVCs in the range will use the global PPPoE profile.

	Command or Action	Purpose
Step 6	<p>pvc-in-range [<i>pvc-name</i>] [[<i>vpi</i> /]<i>vci</i>]</p> <p>Example:</p> <pre>Device(config-if-atm-range)# pvc-in-range pvc1 3/104</pre>	Defines an individual PVC within a PVC range and enables ATM PVC-in-range configuration mode.
Step 7	<p>Do one of the following:</p> <ul style="list-style-type: none"> • protocol pppoe [<i>group group-name</i>] • or • encapsulation aal5autopp virtual-template <i>number</i> [<i>group group-name</i>] <p>Example:</p> <pre>Device(config-if-atm-range-pvc)# protocol pppoe group two</pre> <p>Example:</p> <pre>or</pre> <p>Example:</p> <pre>Device(config-if-atm-range-pvc)# encapsulation aal5autopp virtual-template 1 group two</pre>	<p>Enables PPPoE sessions to be established on a PVC within a range.</p> <p>or</p> <p>Configures PPPoE autosense.</p> <p>Note If a PPPoE profile is not assigned to the PVC by using the group <i>group-name</i> option, the PVC will use the global PPPoE profile.</p>
Step 8	<p>end</p> <p>Example:</p> <pre>Device(cfg-if-atm-range-pvc)# end</pre>	(Optional) Exits ATM PVC-in-range configuration mode and returns to privileged EXEC mode.

Assigning a PPPoE Profile to an ATM VC Class

Perform this task to assign a PPPoE profile to an ATM VC class.

SUMMARY STEPS

1. **enable**
2. **configure terminal**
3. **vc-class atm** *vc-class-name*
4. Do one of the following:
 - **protocol pppoe** [**group** *group-name*]
 - or
 - **encapsulation aal5autoppo virtual-template** *number* [**group** *group-name*]
5. **end**

DETAILED STEPS

	Command or Action	Purpose
Step 1	enable Example: Device> enable	Enables privileged EXEC mode. <ul style="list-style-type: none"> • Enter your password if prompted.
Step 2	configure terminal Example: Device# configure terminal	Enters global configuration mode.
Step 3	vc-class atm <i>vc-class-name</i> Example: Device(config)# vc-class atm class1	Creates an ATM VC class and enters ATM VC class configuration mode. <ul style="list-style-type: none"> • A VC class can be applied to an ATM interface, subinterface, or VC.
Step 4	Do one of the following: <ul style="list-style-type: none"> • protocol pppoe [group <i>group-name</i>] • or • encapsulation aal5autoppo virtual-template <i>number</i> [group <i>group-name</i>] Example: Device(config-vc-class)# protocol pppoe group two	Enables PPPoE sessions to be established. <p>or</p> Configures PPPoE autosense.

Note If a PPPoE profile is not assigned by using the **group** *group-name* option, the PPPoE sessions will be established with the global PPPoE profile.

	Command or Action	Purpose
	Example: <pre>Device(config-vc-class)# encapsulation aal5autopp virtual-template 1 group two</pre>	
Step 5	end Example: <pre>Device(config-vc-class)# end</pre>	(Optional) Exits ATM VC class configuration mode and returns to privileged EXEC mode.

Configuring Different MAC Addresses on PPPoE

The Configurable MAC Address for PPPoE feature configures the MAC address on ATM PVCs in a broadband access (BBA) group to use a different MAC address for PPP over Ethernet over ATM (PPPoEoA).

Perform this task to configure different MAC addresses on PPPoE and enable the aggregation device to bridge packets from Gigabit Ethernet to the appropriate PVC.

Before You Begin

A BBA group profile should already exist. The BBA group commands are used to configure broadband access on aggregation and client devices that use PPPoE, and routed bridge encapsulation (RBE).

Perform this task to configure different MAC addresses on PPPoE and enable the aggregation device to bridge packets from Gigabit Ethernet to the appropriate PVC.

SUMMARY STEPS

1. **enable**
2. **configure terminal**
3. **bba-group pppoe** {*bba-group-name* | **global**}
4. **mac-address** {**autoselect** | *mac-address*}
5. **end**
6. **show pppoe session**

DETAILED STEPS

	Command or Action	Purpose
Step 1	enable Example: <pre>Device> enable</pre>	Enables privileged EXEC mode. <ul style="list-style-type: none"> • Enter your password if prompted.

	Command or Action	Purpose
Step 2	configure terminal Example: Device# configure terminal	Enters global configuration mode.
Step 3	bba-group pppoe {bba-group-name global} Example: Device(config)# bba-group pppoe group1	Enters BBA group configuration mode.
Step 4	mac-address {autoselect mac-address} Example: Device(config-bba-group)# mac-address autoselect	Selects the MAC address, as follows: <ul style="list-style-type: none"> • autoselect --Automatically selects the MAC address based on the ATM interface address, plus 7. • mac-address --Standardized data link layer address having a 48-bit MAC address. Also known as a hardware address, MAC layer address, and physical address. All PPPoEoA sessions use the MAC address specified on the BBA group, which are applied on the VC.
Step 5	end Example: Device(config-bba-group)# end	Exits BBA group configuration mode.
Step 6	show pppoe session Example: Device# show pppoe session	Displays the MAC address as the local MAC (LocMac) address on the last line of the display.

Examples

The following example displays the MAC address as LocMac:

```
Device# show pppoe session
1 session in LOCALLY_TERMINATED (PTA) State
  1 session total
Uniq ID  PPPoE  RemMAC          Port          VT  VA
State
          SID  LocMAC
          3    3  000b.fdc9.0001  ATM3/0.1      1  Vi2.1
PTA
          0008.7c55.a054  VC:  1/50          UP
LocMAC is burned in mac-address of ATM interface(0008.7c55.a054).
```

Configuring PPPoE Session Recovery After Reload

Perform this task to configure the aggregation device to send PPPoE active discovery terminate (PADT) packets to the CPE device upon receipt of PPPoE packets on "half-active" PPPoE sessions (a PPPoE session that is active on the CPE end only).

If the PPP keepalive mechanism is disabled on a customer premises equipment (CPE) device, a PPP over Ethernet (PPPoE) session will hang indefinitely after an aggregation device reload. The PPPoE Session Recovery After Reload feature enables the aggregation device to attempt to recover PPPoE sessions that failed because of reload by notifying CPE devices about the PPPoE session failures.

The PPPoE protocol relies on the PPP keepalive mechanism to detect link or peer device failures. If PPP detects a failure, it terminates the PPPoE session. If the PPP keepalive mechanism is disabled on a CPE device, the CPE device has no way to detect link or peer device failures over PPPoE connections. When an aggregation device that serves as the PPPoE session endpoint reloads, the CPE device will not detect the connection failure and will continue to send traffic to the aggregation device. The aggregation device will drop the traffic for the failed PPPoE session.

The **sessions auto cleanup** command enables an aggregation device to attempt to recover PPPoE sessions that existed before a reload. When the aggregation device detects a PPPoE packet for a half-active PPPoE session, the device notifies the CPE of the PPPoE session failure by sending a PPPoE PADT packet. The CPE device is expected to respond to the PADT packet by taking failure recovery action.

SUMMARY STEPS

1. **enable**
2. **configure terminal**
3. **bba-group pppoe {group-name | global}**
4. **sessions auto cleanup**
5. **end**

DETAILED STEPS

	Command or Action	Purpose
Step 1	enable Example: Device> enable	Enables privileged EXEC mode. • Enter your password if prompted.
Step 2	configure terminal Example: Device# configure terminal	Enters global configuration mode.
Step 3	bba-group pppoe {group-name global} Example: Device(config)# bba-group pppoe global	Defines a PPPoE profile and enters BBA group configuration mode. • The global keyword creates a profile that will serve as the default profile for any PPPoE port that is not assigned a specific profile.

	Command or Action	Purpose
Step 4	sessions auto cleanup Example: Device (config-bba-group) # sessions auto cleanup	Configures an aggregation device to attempt to recover PPPoE sessions that failed because of reload by notifying CPE devices about the PPPoE session failures.
Step 5	end Example: Device (config-bba-group) # end	(Optional) Exits BBA group configuration mode and returns to privileged EXEC mode.

Troubleshooting Tips

Use the `show pppoe session` and `debug pppoe` commands to troubleshoot PPPoE sessions.

Monitoring and Maintaining PPPoE Profiles

SUMMARY STEPS

1. `enable`
2. `show pppoe session [all | packets]`
3. `clear pppoe {interface type number [vc {[vpi /]vci | vc-name}] | rmac mac-addr [sid session-id] | all}`
4. `debug pppoe {data | errors | events | packets} [rmac remote-mac-address | interface type number [vc {[vpi /]vci | vc-name}]]`

DETAILED STEPS

	Command or Action	Purpose
Step 1	enable Example: Device> enable	Enables privileged EXEC mode. <ul style="list-style-type: none"> • Enter your password if prompted.
Step 2	show pppoe session [all packets] Example: Device# show pppoe session all	Displays information about active PPPoE sessions.
Step 3	clear pppoe {interface type number [vc {[vpi /]vci vc-name}] rmac mac-addr [sid session-id] all}	Terminates PPPoE sessions.

	Command or Action	Purpose
	Example: Device# <code>clear pppoe interface atm 0/0/0.0</code>	
Step 4	debug pppoe {data errors events packets} [rmac remote-mac-address interface type number [vc {[vpi /]vci vc-name}]] Example: Device# <code>debug pppoe events</code>	Displays debugging information for PPPoE sessions.

Configuration Examples for Providing Protocol Support for Broadband Access Aggregation of PPPoE Sessions

Example: PPPoE Profiles Configuration

The following example shows the configuration of three PPPoE profiles: vpn1, vpn2, and a global PPPoE profile. The profiles vpn1 and vpn2 are assigned to PVCs, VC classes, VLANs, and PVC ranges. Any Gigabit Ethernet interface, VLAN, PVC, PVC range, or VC class that is configured for PPPoE but is not assigned either profile vpn1 or vpn2 (such as VC class class-pppoe-global) will use the global profile.

```

bba-group pppoe global
  virtual-template 1
  sessions max limit 8000
  sessions per-vc limit 8
  sessions per-mac limit 2
bba-group pppoe group1
  virtual-template 1
  sessions per-vlan throttle 1 10 50
!
interface GigabitEthernet5/0/0.2
  encapsulation dot1q 20 second-dot1q 201
  pppoe enable group group1
!
bba-group pppoe vpn1
  virtual-template 1
  sessions per-vc limit 2
  sessions per-mac limit 1
!
bba-group pppoe vpn2
  virtual-template 2
  sessions per-vc limit 2
  sessions per-mac limit 1 !
vc-class atm class-pppoe-global
  protocol pppoe
!
vc-class atm class-pppox-auto
  encapsulation aal5autoppp virtual-template 1 group vpn1
!
vc-class atm class-pppoe-1
  protocol pppoe group vpn1

```

```

!
vc-class atm class-pppoe-2
  protocol pppoe group vpn2
!
interface Loopback1
  ip address 10.1.1.1 255.255.255.0
!
interface ATM1/0.10 multipoint
  range range-pppoe-1 pvc 100 109
  protocol pppoe group vpn1
!
interface ATM1/0.20 multipoint
  class-int class-pppox-auto
  pvc 0/200
    encapsulation aal5autoppp virtual-template 1
  !
  pvc 0/201
  !
  pvc 0/202
    encapsulation aal5autoppp virtual-template 1 group vpn2
  !
  pvc 0/203
    class-vc class-pppoe-global
  !
!
interface gigabitEthernet0/2/3.1
  encapsulation dot1Q 4
  pppoe enable group vpn1
!
interface gigabitEthernet0/2/3.2
  encapsulation dot1Q 2
  pppoe enable group vpn2
!
interface ATM0/6/0.101 point-to-point
  ip address 10.12.1.63 255.255.255.0
  pvc 0/101
  !
interface ATM0/6/0.102 point-to-point
  ip address 10.12.2.63 255.255.255.0
  pvc 0/102
  !
interface Virtual-Template1
  ip unnumbered loopback 1
  no logging event link-status
  no keepalive
  peer default ip address pool pool-1
  ppp authentication chap
!
interface Virtual-Template2
  ip unnumbered loopback 1
  no logging event link-status
  no keepalive
  peer default ip address pool pool-2
  ppp authentication chap
!
ip local pool pool-1 198.x.1.z 198.x.1.y
ip local pool pool-2 198.x.2.z 198.x.2.y
!

```

Example: MAC Address of the PPPoEoA Session as the Burned-In MAC Address

In the following example, neither address autoselect nor a MAC address is configured on the BBA group. The MAC address is not configured on the ATM interface (the default condition). The **show pppoe session** command is used to confirm that the MAC address of the PPPoEoA session is the burned-in MAC address of the ATM interface.

```

bba-group pppoe one
  virtual-template 1

```

```

interface ATM0/3/0.0
  no ip address
  no ip route-cache
  no atm ilmi-keepalive
!
interface ATM0/3/0.1 multipoint
  no ip route-cache
  pvc 1/50
    encapsulation aal5snap
    protocol pppoe group one
!
Router# show pppoe session
1 session in LOCALLY_TERMINATED (PTA) State
  1 session total
Uniq ID  PPPoE  RemMAC          Port          VT  VA
State
          SID  LocMAC          VA-st
          3    3  000b.fdc9.0001  ATM0/3/0.1    1  Vi2.1
PTA
          0008.7c55.a054  VC:  1/50          UP
LocMAC is burned in mac-address of ATM interface(0008.7c55.a054).

```

Example Address Autoselect Configured and MAC Address Not Configured

In the following example, address autoselect is configured on the BBA group, and the MAC address is not configured on the ATM interface. The **show pppoe session** command displays the MAC address of the interface, plus 7.

```

bba-group pppoe one
  virtual-template 1
  mac-address autoselect
!
interface ATM3/0
  no ip address
  no ip route-cache
  no atm ilmi-keepalive
!
interface ATM3/0.1 multipoint
  no ip route-cache
  pvc 1/50
    encapsulation aal5snap
    protocol pppoe group one
Router# show pppoe session
  1 session in LOCALLY_TERMINATED (PTA) State
  1 session total
Uniq ID  PPPoE  RemMAC          Port          VT  VA
State
          SID  LocMAC          VA-st
          5    5  000b.fdc9.0001  ATM0/3/0.1    1  Vi2.1
PTA
          0008.7c55.a05b  VC:  1/50          UP
LocMAC = burned in mac-address of ATM interface + 7 (0008.7c55.a05b)

```

Example: MAC Address Configured on the ATM Interface

In the following example, neither autoselect nor the MAC address is configured on the BBA group, but the MAC address is configured on the ATM interface, as indicated by the report from the **show pppoe session** command:

```

bba-group pppoe one
  virtual-template 1
interface ATM0/3/0.0
  mac-address 0001.0001.0001

```



```

no ip address
no ip route-cache
no atm ilmi-keepalive
!
interface ATM0/3/0.1 multipoint
no ip route-cache
pvc 1/50
encapsulation aal5snap
protocol pppoe group one
!
Router# show pppoe session
  1 session in LOCALLY_TERMINATED (PTA) State
  1 session total
Uniq ID  PPPoE  RemMAC          Port          VT  VA
State
          SID  LocMAC          VA-st
      7      7  000b.fdc9.0001  ATM0/3/0.1    1  Vi2.1
PTA
          0001.0001.0001  VC:  1/50          UP
LocMAC = configured mac-address on atm interface(0001.0001.0001).

```

Example: MAC Address Configured on the BBA Group

In the following example, the MAC address is configured on the BBA group. The display from the **show pppoe session** command indicates that all PPPoEoA sessions on the ATM interface associated with the BBA group use the same MAC address as specified on the BBA group.

```

bba-group pppoe one
virtual-template 1
mac-address 0002.0002.0002
interface ATM0/3/0.0
mac-address 0001.0001.0001
no ip address
no ip route-cache
no atm ilmi-keepalive
!
interface ATM0/3/0.1 multipoint
no ip route-cache
pvc 1/50
encapsulation aal5snap
protocol pppoe group one
Router# show pppoe session
  1 session in LOCALLY_TERMINATED (PTA) State
  1 session total
Uniq ID  PPPoE  RemMAC          Port          VT  VA
State
          SID  LocMAC          VA-st
      8      8  000b.fdc9.0001  ATM0/3/0.1    1  Vi2.1
PTA
          0002.0002.0002  VC:  1/50          UP
LocMac(Mac address of PPPoEoA session) is mac-address specified on bba-group one
(0002.0002.0002)

```

Example: PPPoE Session Recovery After Reload

In the following example, the router attempts to recover failed PPPoE sessions on PVCs in the range-pppoe-1 ATM PVC range.

```

bba-group pppoe group1
virtual-template 1
sessions auto cleanup
!
interface ATM1/0.10 multipoint
range range-pppoe-1 pvc 100 109

```

```

protocol pppoe group group1
!
interface virtual-template1
 ip address negotiated
 no peer default ip address
 ppp authentication chap

```

Where to Go Next

- If you want to establish PPPoE session limits for sessions on a specific permanent virtual circuit or VLAN configured on an Layer Two Tunneling Protocol (L2TP) access concentrator, see the Establishing PPPoE Session Limits per NAS Port module.
- If you want to use service tags to enable a PPPoE server to offer PPPoE clients a selection of service during call setup, see the Offering PPPoE Clients a Selection of Services During Call Setup module.
- If you want to enable an L2TP access concentrator to relay active discovery and service selection functionality for PPPoE over an L2TP control channel to an L2TP network server (LNS) or tunnel switch, see the Enabling PPPoE Relay Discovery and Service Selection Functionality module.
- If you want to configure the transfer upstream of the PPPoX session speed value, see the Configuring Upstream Connections Speed Transfer module.
- If you want to use SNMP to monitor PPPoE sessions, see the Monitoring PPPoE Sessions with SNMP module.
- If you want to identify a physical subscriber line for RADIUS communication with a RADIUS server, see the Identifying a Physical Subscriber Line for RADIUS Access and Accounting module.
- If you want to configure a Cisco Subscriber Service Switch, see the Configuring Cisco Subscriber Service Switch Policies module.

Additional References

Related Documents

Related Topic	Document Title
Cisco IOS commands	Master Command List
Broadband and DSL commands	Broadband Access Aggregation and DSL Command Reference
Broadband access aggregation concepts	<i>Understanding Broadband Access Aggregation</i>
Tasks for preparing for broadband access aggregation.	<i>Preparing for Broadband Access Aggregation module</i>
Establishing PPPoE session limits for sessions on a specific permanent virtual circuit or VLAN configured on an Layer Two Tunneling Protocol (L2TP) access concentrator	<i>Establishing PPPoE Session Limits per NAS Port</i>

Related Topic	Document Title
Using service tags to enable a PPPoE server to offer PPPoE clients a selection of service during call setup	<i>Offering PPPoE Clients a Selection of Services During Call Setup</i>
Enabling an L2TP access concentrator to relay active discovery and service selection functionality for PPPoE over an L2TP control channel to an L2TP network server (LNS) or tunnel switch	<i>Enabling PPPoE Relay Discovery and Service Selection Functionality</i>
Configuring the transfer upstream of the PPPoX session speed value	<i>Configuring Upstream Connections Speed Transfer</i>
Using SNMP to monitor PPPoE sessions	<i>Monitoring PPPoE Sessions with SNMP</i>
Identifying a physical subscribe line for RADIUS communication with a RADIUS server	<i>Identifying a Physical Subscriber Line for RADIUS Access and Accounting</i>
Configuring a Cisco Subscriber Service Switch	<i>Configuring ISG Policies for Automatic Subscriber Logon</i>

Standards/RFCs

Standards	Title
No new or modified standards are supported by this feature, and support for existing standards has not been modified by this feature.	--
RFC 1483	Multiprotocol Encapsulation over ATM Adaptation Layer 5
RFC 2516	<i>A Method for Transmitting PPP over Ethernet (PPPoE)</i>

Technical Assistance

Description	Link
The Cisco Support and Documentation website provides online resources to download documentation, software, and tools. Use these resources to install and configure the software and to troubleshoot and resolve technical issues with Cisco products and technologies. Access to most tools on the Cisco Support and Documentation website requires a Cisco.com user ID and password.	http://www.cisco.com/cisco/web/support/index.html

Feature Information for Providing Protocol Support for Broadband Access Aggregation of PPPoE Sessions

The following table provides release information about the feature or features described in this module. This table lists only the software release that introduced support for a given feature in a given software release train. Unless noted otherwise, subsequent releases of that software release train also support that feature.

Use Cisco Feature Navigator to find information about platform support and Cisco software image support. To access Cisco Feature Navigator, go to www.cisco.com/go/cfn. An account on Cisco.com is not required.

Table 3: Feature Information for Providing Protocol Support for Broadband Access Aggregation of PPPoE Sessions

Feature Name	Releases	Feature Information
PPPoE Connection Throttling	Cisco IOS XE Release 2.1	The PPPoE Connection Throttling feature limits PPPoE connection requests to help prevent intentional denial-of-service attacks and unintentional PPP authentication loops. This feature implements session throttling on the PPPoE server to limit the number of PPPoE session requests that can be initiated from a MAC address or virtual circuit during a specified period of time.
PPPoE Server Restructuring and PPPoE Profiles	Cisco IOS XE Release 2.1	This feature was introduced on Cisco ASR 1000 Series Aggregation Services Routers.
PPPoE VLAN Session Throttling	Cisco IOS XE Release 2.4	This feature allows for PPPoE VLAN Session throttling support.



PPP for IPv6

- [Finding Feature Information](#), page 37
- [Information About PPP for IPv6](#), page 37
- [How to Configure PPP for IPv6](#), page 39
- [Configuration Examples for PPP for IPv6](#), page 41
- [Additional References](#), page 42
- [Feature Information for PPP for IPv6](#), page 43

Finding Feature Information

Your software release may not support all the features documented in this module. For the latest caveats and feature information, see [Bug Search Tool](#) and the release notes for your platform and software release. To find information about the features documented in this module, and to see a list of the releases in which each feature is supported, see the feature information table.

Use Cisco Feature Navigator to find information about platform support and Cisco software image support. To access Cisco Feature Navigator, go to www.cisco.com/go/cfn. An account on Cisco.com is not required.

Information About PPP for IPv6

Accounting Start and Stop Messages

PPP calls a registry to allow DHCPv6 to append the delegated prefix information to accounting start and stop messages. When accounting is configured for a DHCPv6 pool, accounting interim packets are sent to broadband sessions after binding is provided from the pool.

Forced Release of a Binding

The DHCPv6 server maintains an automatic binding table in memory to track the assignment of some configuration parameters, such as prefixes between the server and its clients. The automatic bindings can be stored permanently in the database agent, which can be, for example, a remote TFTP server or local NVRAM file system.

DHCPv6 invokes a routine when the virtual interface used by PPP terminates. This routine automatically releases any delegated prefix bindings associated with the PPP virtual interface that is being terminated.

When a PPP virtual interface terminates, the routine runs through the full table of DHCPv6 bindings checking for the matching interface. Because PPP uses a virtual interface, this subroutine clears any related lease information when the PPP connection terminates.



Note

In IPv6 broadband deployment using DHCPv6, you must enable release of prefix bindings associated with a PPP virtual interface using the **ipv6 dhcp binding track ppp** command. This ensures that DHCPv6 bindings are tracked together with PPP sessions, and in the event of DHCP REBIND failure, the client initiates DHCPv6 negotiation again.

Delegated-IPv6-Prefix

The Delegated-IPv6-Prefix attribute calls DHCPv6 to parse and store AAA attribute information. PPP sends the accounting start and stop messages for PPP sessions.

The following is an example of a Delegated-IPv6-Prefix attribute:

```
cisco-avpair = ipv6:delegated-prefix=2001:DB8::/64
```



Note

The Delegated-IPv6-Prefix attribute does not support the Cisco VSA format. If you try add this attribute in the cisco-vsa format in the profile, the RADIUS server response fails. Use only the IETF attribute for Delegated-IPv6-Prefix.

PPP IPv6 Accounting Delay Enhancements

This feature enhances accounting records for dual-stack networks. It ensures that a unique IPv6 address is assigned to PPP IPv6 and IPv4 sessions for IP addresses that are received from RADIUS.

When this feature is enabled, it automatically creates a database to hold new incoming access-accept responses from RADIUS. The access-accept responses in this database are then checked for duplicates of a specific set of attributes. If the attributes are already present in the database, then the RADIUS server has already offered them to an existing session; therefore, the new session is immediately removed and a stop-record message sent. If none of the specific set of attributes are in the database, they are immediately added to the database, and the session proceeds normally. When the session is removed, the entries in the database are also removed.

The following RADIUS attributes are tracked in the database and checked at access-accept time:

- Framed-IPv6-Prefix

- Delegated-IPv6-Prefix

The attributes are available as standard RFC-defined binary format, or as Cisco VSAs. (The Delegated-IPv6-Prefix attribute currently does not have a VSA definition in AAA.)

How to Configure PPP for IPv6

Enabling the Sending of Accounting Start and Stop Messages

SUMMARY STEPS

1. **enable**
2. **configure terminal**
3. **ipv6 dhcp pool *poolname***
4. **accounting *mlist***

DETAILED STEPS

	Command or Action	Purpose
Step 1	enable Example: Device> enable	Enables privileged EXEC mode. <ul style="list-style-type: none"> • Enter your password if prompted.
Step 2	configure terminal Example: Device# configure terminal	Enters global configuration mode.
Step 3	ipv6 dhcp pool <i>poolname</i> Example: Device(config)# ipv6 dhcp pool pool1	Configures a DHCP for IPv6 configuration information pool and enters DHCP for IPv6 pool configuration mode.
Step 4	accounting <i>mlist</i> Example: Device(config-dhcp)# accounting list1	Enables accounting start and stop messages to be sent.

Removing Delegated Prefix Bindings

Perform this task to release any delegated prefix bindings associated with the PPP virtual interface that is being terminated.

SUMMARY STEPS

1. **enable**
2. **configure terminal**
3. **interface *type number***
4. **ipv6 dhcp bindings track ppp**

DETAILED STEPS

	Command or Action	Purpose
Step 1	enable Example: Device> enable	Enables privileged EXEC mode. <ul style="list-style-type: none"> • Enter your password if prompted.
Step 2	configure terminal Example: Device# configure terminal	Enters global configuration mode.
Step 3	interface <i>type number</i> Example: Device(config)# interface VirtualAccess2.2	Specifies an interface type and number, and places the router in interface configuration mode.
Step 4	ipv6 dhcp bindings track ppp Example: Device(config-if)# ipv6 dhcp bindings track ppp	Releases any delegated prefix leases associated with the PPP virtual interface that is being terminated.

Configuring PPP IPv6 Accounting Delay Enhancements

SUMMARY STEPS

1. `enable`
2. `configure terminal`
3. `ppp unique address access-accept`

DETAILED STEPS

	Command or Action	Purpose
Step 1	enable Example: Router> enable	Enables privileged EXEC mode. <ul style="list-style-type: none"> • Enter your password if prompted.
Step 2	configure terminal Example: Router# configure terminal	Enters global configuration mode.
Step 3	ppp unique address access-accept Example: Router(config)# ppp unique address access-accept	Tracks duplicate addresses received from RADIUS and creates a standalone database.

Configuration Examples for PPP for IPv6

Example: Enabling the Sending of Accounting Start and Stop Messages

This example shows how to enable a device to send accounting start and stop messages.

```
Device(config)# ipv6 dhcp pool pool1
Device(config-dhcp)# accounting list1
```

Additional References

Related Documents

Related Topic	Document Title
IPv6 addressing and connectivity	<i>IPv6 Configuration Guide</i>
Cisco IOS commands	Cisco IOS Master Commands List, All Releases
IPv6 commands	Cisco IOS IPv6 Command Reference
Cisco IOS IPv6 features	Cisco_IOS_IPv6_Feature_Mapping

Standards and RFCs

Standard/RFC	Title
RFCs for IPv6	

MIBs

MIB	MIBs Link
	To locate and download MIBs for selected platforms, Cisco IOS releases, and feature sets, use Cisco MIB Locator found at the following URL: http://www.cisco.com/go/mibs

Technical Assistance

Description	Link
The Cisco Support and Documentation website provides online resources to download documentation, software, and tools. Use these resources to install and configure the software and to troubleshoot and resolve technical issues with Cisco products and technologies. Access to most tools on the Cisco Support and Documentation website requires a Cisco.com user ID and password.	http://www.cisco.com/cisco/web/support/index.html

Feature Information for PPP for IPv6

The following table provides release information about the feature or features described in this module. This table lists only the software release that introduced support for a given feature in a given software release train. Unless noted otherwise, subsequent releases of that software release train also support that feature.

Use Cisco Feature Navigator to find information about platform support and Cisco software image support. To access Cisco Feature Navigator, go to www.cisco.com/go/cfn. An account on Cisco.com is not required.

Table 4: Feature Information for PPP for IPv6

Feature Name	Releases	Feature Information
PPP Enhancement for Broadband IPv6	Cisco IOS XE Release 2.5	IPv6 supports this feature. The following commands were introduced or modified: accounting, ipv6 dhcp bindings track ppp, ipv6 dhcp pool.
PPP IPv6 Accounting Delay Enhancements	Cisco IOS XE Release 3.2S	IPv6 supports this feature. The following commands were introduced or modified: ppp unique address accept-access.
SSO/ISSU Support for Per-User IPv6 ACL for PPP Sessions	Cisco IOS XE Release 3.2.1S	IPv6 supports this feature. No commands were introduced or modified.



DHCP for IPv6 Broadband

The DHCP for IPv6 Broadband feature highlights the DHCP enhancements that support IPv6 broadband deployments. This feature briefly explains the different ways a delegating device selects prefixes for a requesting device, enabling accounting messages on a device, and forced release of delegated prefix bindings associated with a PPP virtual interface when the PPP virtual interface is terminated.

- [Finding Feature Information, page 45](#)
- [Information About DHCP for IPv6 Broadband, page 45](#)
- [How to Configure DHCP for IPv6 Broadband, page 46](#)
- [Configuration Examples for DHCP for IPv6 Broadband, page 48](#)
- [Additional References, page 49](#)
- [Feature Information for DHCP for IPv6 Broadband, page 50](#)

Finding Feature Information

Your software release may not support all the features documented in this module. For the latest caveats and feature information, see [Bug Search Tool](#) and the release notes for your platform and software release. To find information about the features documented in this module, and to see a list of the releases in which each feature is supported, see the feature information table.

Use Cisco Feature Navigator to find information about platform support and Cisco software image support. To access Cisco Feature Navigator, go to www.cisco.com/go/cfn. An account on Cisco.com is not required.

Information About DHCP for IPv6 Broadband

Prefix Delegation

An IPv6 prefix delegating device selects IPv6 prefixes to be assigned to a requesting device upon receiving a request from the client. The delegating device might select prefixes for a requesting device in the following ways:

- Dynamic assignment from a pool of available prefixes.
- Dynamic assignment from a pool name obtained from the RADIUS server.
- Assignment of prefix obtained from the RADIUS server.

Contrary to IPv4 address assignment, an IPv6 user will be assigned a prefix, not a single address. Typically the Internet service provider (ISP) assigns a 64- or 48-bit prefix.

Accounting Start and Stop Messages

PPP calls a registry to allow DHCPv6 to append the delegated prefix information to accounting start and stop messages. When accounting is configured for a DHCPv6 pool, accounting interim packets are sent to broadband sessions after binding is provided from the pool.

Forced Release of a Binding

The DHCPv6 server maintains an automatic binding table in memory to track the assignment of some configuration parameters, such as prefixes between the server and its clients. The automatic bindings can be stored permanently in the database agent, which can be, for example, a remote TFTP server or local NVRAM file system.

DHCPv6 invokes a routine when the virtual interface used by PPP terminates. This routine automatically releases any delegated prefix bindings associated with the PPP virtual interface that is being terminated.

When a PPP virtual interface terminates, the routine runs through the full table of DHCPv6 bindings checking for the matching interface. Because PPP uses a virtual interface, this subroutine clears any related lease information when the PPP connection terminates.



Note

In IPv6 broadband deployment using DHCPv6, you must enable release of prefix bindings associated with a PPP virtual interface using the **ipv6 dhcp binding track ppp** command. This ensures that DHCPv6 bindings are tracked together with PPP sessions, and in the event of DHCP REBIND failure, the client initiates DHCPv6 negotiation again.

How to Configure DHCP for IPv6 Broadband

Enabling the Sending of Accounting Start and Stop Messages

SUMMARY STEPS

1. **enable**
2. **configure terminal**
3. **ipv6 dhcp pool *poolname***
4. **accounting *mlist***

DETAILED STEPS

	Command or Action	Purpose
Step 1	enable Example: Device> enable	Enables privileged EXEC mode. <ul style="list-style-type: none"> • Enter your password if prompted.
Step 2	configure terminal Example: Device# configure terminal	Enters global configuration mode.
Step 3	ipv6 dhcp pool <i>poolname</i> Example: Device (config)# ipv6 dhcp pool pool1	Configures a DHCP for IPv6 configuration information pool and enters DHCP for IPv6 pool configuration mode.
Step 4	accounting <i>mlist</i> Example: Device (config-dhcp)# accounting list1	Enables accounting start and stop messages to be sent.

Removing Delegated Prefix Bindings

Perform this task to release any delegated prefix bindings associated with the PPP virtual interface that is being terminated.

SUMMARY STEPS

1. **enable**
2. **configure terminal**
3. **interface *type number***
4. **ipv6 dhcp bindings track ppp**

DETAILED STEPS

	Command or Action	Purpose
Step 1	enable	Enables privileged EXEC mode.

	Command or Action	Purpose
	Example: Device> enable	<ul style="list-style-type: none"> • Enter your password if prompted.
Step 2	configure terminal Example: Device# configure terminal	Enters global configuration mode.
Step 3	interface <i>type number</i> Example: Device(config)# interface VirtualAccess2.2	Specifies an interface type and number, and places the router in interface configuration mode.
Step 4	ipv6 dhcp bindings track ppp Example: Device(config-if)# ipv6 dhcp bindings track ppp	Releases any delegated prefix leases associated with the PPP virtual interface that is being terminated.

Configuration Examples for DHCP for IPv6 Broadband

Example: Enabling the Sending of Accounting Start and Stop Messages

This example shows how to enable a device to send accounting start and stop messages.

```
Device(config)# ipv6 dhcp pool pool1
Device(config-dhcp)# accounting list1
```

Example: Configuration for a Prefix Allocated from a Local Pool

DHCPv6 clients are connected to the DHCPv6 server on Gigabit Ethernet interface 0/0/0. The server is configured to use parameters from the DHCP pool called dhcp-pool. This pool provides clients with the IPv6 address of a DNS server and the domain name to be used. It also specifies that prefixes can be delegated from the prefix pool called client-prefix-pool1. The prefixes delegated will have valid and preferred lifetimes of 1800 and 600 seconds respectively. The prefix pool named client-prefix-pool1 has a prefix of length /40 from which it will delegate (sub) prefixes of length /48.

```
ipv6 dhcp pool dhcp-pool
prefix-delegation pool client-prefix-pool1 lifetime 1800 600
dns-server 2001:DB8:3000:3000::42
domain-name example.com
```



```

!
interface GigabitEthernet0/0/0
description downlink to clients
ipv6 address FEC0:240:104:2001::139/64
ipv6 dhcp server dhcp-pool
!
ipv6 local pool client-prefix-pool1 2001:DB8:1200::/40 48

```

Additional References

Related Documents

Related Topic	Document Title
IPv6 addressing and connectivity	<i>IPv6 Configuration Guide</i>
Cisco IOS commands	Cisco IOS Master Commands List, All Releases
IPv6 commands	Cisco IOS IPv6 Command Reference
Cisco IOS IPv6 features	Cisco IOS IPv6 Feature Mapping

Standards and RFCs

Standard/RFC	Title
RFCs for IPv6	<i>IPv6 RFCs</i>

MIBs

MIB	MIBs Link
	To locate and download MIBs for selected platforms, Cisco IOS releases, and feature sets, use Cisco MIB Locator found at the following URL: http://www.cisco.com/go/mibs

Technical Assistance

Description	Link
The Cisco Support and Documentation website provides online resources to download documentation, software, and tools. Use these resources to install and configure the software and to troubleshoot and resolve technical issues with Cisco products and technologies. Access to most tools on the Cisco Support and Documentation website requires a Cisco.com user ID and password.	http://www.cisco.com/cisco/web/support/index.html

Feature Information for DHCP for IPv6 Broadband

The following table provides release information about the feature or features described in this module. This table lists only the software release that introduced support for a given feature in a given software release train. Unless noted otherwise, subsequent releases of that software release train also support that feature.

Use Cisco Feature Navigator to find information about platform support and Cisco software image support. To access Cisco Feature Navigator, go to www.cisco.com/go/cfn. An account on Cisco.com is not required.

Table 5: Feature Information for DHCP for IPv6 Broadband

Feature Name	Releases	Feature Information
DHCP Enhancements to Support IPv6 Broadband Deployments	Cisco IOS XE Release 2.5	<p>The feature highlights the DHCP enhancements that support IPv6 broadband deployments, such as, the different ways a delegating device selects prefixes for a requesting device, enabling accounting messages on a device, and forced release of delegated prefix bindings associated with a PPP virtual interface when the PPP virtual interface is terminated.</p> <p>The following commands were introduced or modified: accounting, ipv6 dhcp bindings track ppp, ipv6 dhcp pool.</p>
DHCPv6 Prefix Delegation RADIUS VSA	Cisco IOS XE Release 2.5	When the user requests a prefix from the prefix delegator, typically the NAS, the prefix is allocated using DHCPv6.

Feature Name	Releases	Feature Information
DHCP Accounting Attribute	Cisco IOS XE Release 3.13S	<p>In Cisco IOS XE Release 3.13S, support was added for the Cisco ASR 1000 Series Routers</p> <p>The DHCP Accounting Attribute feature allows DHCPv6 to append delegated prefix information to accounting start and stop messages.</p>



Providing Protocol Support for Broadband Access Aggregation of PPP over ATM Sessions

PPP over ATM enables a high-capacity central site router with an ATM interface to terminate multiple remote Point-to-Point Protocol (PPP) connections. PPP over ATM provides security validation per user, IP address pooling, and service selection capability.

- [Finding Feature Information, page 53](#)
- [Prerequisites for Providing Protocol Support for Broadband Access Aggregation of PPP over ATM Sessions, page 54](#)
- [Restrictions for Providing Protocol Support for Broadband Access Aggregation of PPP over ATM Sessions, page 54](#)
- [Information About Providing Protocol Support for Broadband Access Aggregation of PPP over ATM Sessions, page 54](#)
- [How to Provide Protocol Support for Broadband Access Aggregation of PPP over ATM Sessions, page 55](#)
- [Configuration Examples for PPP over ATM, page 65](#)
- [Additional References, page 68](#)
- [Feature Information for Providing Protocol Support for Broadband Access Aggregation of PPP over ATM Sessions, page 68](#)

Finding Feature Information

Your software release may not support all the features documented in this module. For the latest caveats and feature information, see [Bug Search Tool](#) and the release notes for your platform and software release. To find information about the features documented in this module, and to see a list of the releases in which each feature is supported, see the feature information table.

Use Cisco Feature Navigator to find information about platform support and Cisco software image support. To access Cisco Feature Navigator, go to www.cisco.com/go/cfn. An account on Cisco.com is not required.

Prerequisites for Providing Protocol Support for Broadband Access Aggregation of PPP over ATM Sessions

Perform the preparation tasks in the "Preparing for Broadband Access Aggregation" module.

Restrictions for Providing Protocol Support for Broadband Access Aggregation of PPP over ATM Sessions

PPP over ATM cannot be configured on IETF-compliant Logical Link Control (LLC) encapsulated PPP over ATM.

Information About Providing Protocol Support for Broadband Access Aggregation of PPP over ATM Sessions

Virtual Access Interface

When you configure PPP over ATM, a logical interface known as a *virtual access interface* associates each PPP connection with an ATM virtual circuit (VC). You can create this logical interface by configuring an ATM permanent virtual circuit (PVC) or switched virtual circuit (SVC). This configuration encapsulates each PPP connection in a separate PVC or SVC, thus allowing each PPP connection to terminate at the ATM interface of a device as if received from a typical PPP serial interface.

After you have configured the device for PPP over ATM, the PPP subsystem starts and the device attempts to send a PPP configuration request to the remote peer. If the peer does not respond, the router periodically goes into a listen state and waits for a configuration request from the peer.

Before you create the ATM VC, we recommend that you create and configure a virtual template as described in the "Preparing for Broadband Access Aggregation" module. When the VC is created, the virtual access interface for each VC obtains the configuration from a virtual interface template (virtual template).

The virtual access interface is associated with the VC after the completion of the LCP negotiation. When the PPP session goes down, the virtual access interface is no longer associated with the VC and is returned to the pool of free virtual-access interfaces.

If you set a keepalive timer of the virtual template on the interface, the virtual access interface uses the PPP echo mechanism to verify the existence of the remote peer.

The following types of PPP over ATM connections are supported:

- IETF-compliant Multiplex (MUX) encapsulated PPP over ATM
- IETF-compliant LLC encapsulated PPP over ATM

How to Provide Protocol Support for Broadband Access Aggregation of PPP over ATM Sessions

Configuring IETF-Compliant MUX Encapsulated PPP over ATM on Point-to-Point Subinterface

Internet Engineering Task Force (IETF)-compliant multiplexer (MUX) encapsulated PPP over ATM, also known as *null encapsulation*, allows you to configure PPP over ATM using a VC multiplexed encapsulation mode. This feature complies with IETF RFC 2364 entitled PPP over AAL5.

You can configure ATM PVCs for IETF-compliant MUX encapsulated PPP over ATM on either point-to-point or multipoint subinterfaces.

Perform this task to configure IETF-compliant MUX Encapsulated PPP over ATM point-to-point subinterface.

SUMMARY STEPS

1. **enable**
2. **configure terminal**
3. **interface atm *number.subinterface-number* point-to-point**
4. Do one of the following:
 - **pvc [*name*] vpi / vci**
 -
 - **range [*range-name*] pvc start-vpi / start-vci end-vpi / end-vci**
5. **encapsulation aal5mux ppp virtual-template *number***
6. Do one of the following:
 - **end**

DETAILED STEPS

	Command or Action	Purpose
Step 1	enable Example: Device> enable	Enables privileged EXEC mode. <ul style="list-style-type: none"> • Enter your password if prompted.

	Command or Action	Purpose
Step 2	<p>configure terminal</p> <p>Example:</p> <pre>Device# configure terminal</pre>	Enters global configuration mode.
Step 3	<p>interface atm <i>number.subinterface-number</i> point-to-point</p> <p>Example:</p> <pre>Device(config)# interface atm 1.0 point-to-point</pre>	Specifies the ATM point-to-point subinterface using the appropriate form of the interface atm command ¹ and enters subinterface configuration mode.
Step 4	<p>Do one of the following:</p> <ul style="list-style-type: none"> • pvc [<i>name</i>] <i>vpi</i> / <i>vci</i> • • range [<i>range-name</i>] pvc <i>start-vpi</i> / <i>start-vci</i> <i>end-vpi</i> / <i>end-vci</i> <p>Example:</p> <pre>Device(config-subif)# pvc cisco 0/5</pre> <p>Example:</p> <pre>or</pre> <p>Example:</p> <pre>Device(config-subif)# range range1 pvc 1/200 1/299</pre>	Configures the PVC or a range of PVCs and enters ATM virtual circuit subinterface mode or ATM range subinterface configuration mode.
Step 5	<p>encapsulation aal5mux ppp virtual-template <i>number</i></p> <p>Example:</p> <pre>Device(config-subif-atm-vc)# encapsulation aal5mux ppp virtual-template 3</pre> <p>Example:</p> <pre>or</pre> <p>Example:</p> <pre>Device(config-subif-atm-range)# encapsulation aal5mux ppp virtual-template 3</pre>	Configures VC multiplexed encapsulation on a PVC or PVC range.
Step 6	<p>Do one of the following:</p> <ul style="list-style-type: none"> • end 	Exits ATM virtual circuit range subinterface configuration mode.

	Command or Action	Purpose
	<p>Example:</p> <pre>Device(config-subif-atm-vc)# end</pre> <p>Example:</p> <pre>or</pre> <p>Example:</p> <pre>Device(config-subif-atm-range)# end</pre>	<p>or</p> <p>Exits ATM range subinterface configuration mode.</p>

¹ To determine the correct form of the interface atm command, consult your ATM shared port adapters documentation.

Configuring IETF-Compliant MUX Encapsulated PPP over ATM on a Multipoint Subinterface

Multiple PVCs on multipoint subinterfaces significantly increase the maximum number of PPP-over-ATM sessions running on a device. You can configure IETF-compliant MUX encapsulated PPP over ATM on a single ATM PVC or an ATM PVC range.

Perform this task to configure IETF-compliant MUX Encapsulated PPP over ATM on a multipoint subinterface.

SUMMARY STEPS

1. **enable**
2. **configure terminal**
3. **interface atm** *number.subinterface-number* **multipoint**
4. Do one of the following:
 - **pvc** [*name*] *vpi / vci*
 -
 - **range** [*range-name*] **pvc** *start-vpi / start-vci end-vpi / end-vci*
5. **encapsulation aal5mux ppp virtual-template** *number*
6. Do one of the following:
 - **end**

DETAILED STEPS

	Command or Action	Purpose
Step 1	<p>enable</p> <p>Example:</p> <pre>Device> enable</pre>	<p>Enables privileged EXEC mode.</p> <ul style="list-style-type: none"> • Enter your password if prompted.
Step 2	<p>configure terminal</p> <p>Example:</p> <pre>Device# configure terminal</pre>	<p>Enters global configuration mode.</p>
Step 3	<p>interface atm <i>number.subinterface-number</i> multipoint</p> <p>Example:</p> <pre>Device(config)# interface atm 1/0/0.4 multipoint</pre>	<p>Specifies the ATM multipoint subinterface using the appropriate form of the interface atm command and enters subinterface configuration mode.</p>
Step 4	<p>Do one of the following:</p> <ul style="list-style-type: none"> • pvc [<i>name</i>] <i>vpi</i> / <i>vci</i> • • range [<i>range-name</i>] pvc <i>start-vpi</i> / <i>start-vci</i> <i>end-vpi</i> / <i>end-vci</i> <p>Example:</p> <pre>Device(config-subif)# pvc cisco 0/5</pre> <p>Example:</p> <pre>or</pre> <p>Example:</p> <pre>Device(config-subif)# range range1 pvc 1/200 1/299</pre>	<p>Configures the PVC or a range of PVCs and enters ATM virtual circuit subinterface mode or ATM range subinterface configuration mode.</p>
Step 5	<p>encapsulation aal5mux ppp virtual-template <i>number</i></p> <p>Example:</p> <pre>Device(config-subif-atm-vc)# encapsulation aal5mux ppp virtual-template 3</pre> <p>Example:</p> <pre>or</pre>	<p>Configures VC multiplexed encapsulation on a PVC or PVC range.</p>

	Command or Action	Purpose
	<p>Example:</p> <pre>Device(config-subif-atm-range)# encapsulation aal5mux ppp virtual-template 3</pre>	
Step 6	<p>Do one of the following:</p> <ul style="list-style-type: none"> • end <p>Example:</p> <pre>Device(config-subif-atm-vc) # end</pre> <p>Example:</p> <p>Example:</p> <pre>Device(config-subif-atm-range) # end</pre>	<p>Exits ATM virtual circuit subinterface configuration mode.</p> <p>or</p> <p>Exits ATM range subinterface configuration mode.</p>

Configuring IETF-Compliant LLC Encapsulated PPP over ATM on a Point-to-point Subinterface

IETF-compliant LLC encapsulated PPP over ATM allows you to configure PPP over ATM with LLC encapsulation. It accommodates Frame Relay-to-ATM service interworking (Frame Relay Forum standard FRF.8). There is no equivalent VC multiplexed encapsulation mode for Frame Relay; therefore, LLC encapsulation is required for Frame Relay-to-ATM networking. This version of PPP over ATM also enables you to carry multiprotocol traffic. For example, a VC will carry both PPP and IPX traffic.

The figure below shows Frame Relay-to-ATM interworking.

Figure 1: Frame Relay-to-ATM Interworking



You can configure ATM PVCs for IETF-compliant LLC encapsulated PPP over ATM on either point-to-point or multipoint subinterfaces. Multiple PVCs on multipoint subinterfaces significantly increase the maximum number of PPP-over-ATM sessions running on a router.

Perform this task to configure IETF-compliant LLC encapsulated PPP over ATM PVC or range of PVCs on a point-to-point interface.

SUMMARY STEPS

1. **enable**
2. **configure terminal**
3. **interface atm** *number.subinterface-number* **point-to-point**
4. Do one of the following:
 - **pvc** [*name*] *vpi / vci*
 -
 - **range** [*range-name*] **pvc** *start-vpi / start-vci end-vpi / end-vci*
5. **encapsulation aal15snap**
6. **protocol ppp virtual-template** *number*
7. Do one of the following:
 - **end**

DETAILED STEPS

	Command or Action	Purpose
Step 1	enable Example: Router> enable	Enables privileged EXEC mode. • Enter your password if prompted.
Step 2	configure terminal Example: Router# configure terminal	Enters global configuration mode.
Step 3	interface atm <i>number.subinterface-number</i> point-to-point Example: Router(config)# interface atm 6.200 point-to-point	Specifies the ATM point-to-point or multipoint subinterface using the appropriate form of the interface atm command ² and enters subinterface configuration mode.
Step 4	Do one of the following: <ul style="list-style-type: none"> • pvc [<i>name</i>] <i>vpi / vci</i> • • range [<i>range-name</i>] pvc <i>start-vpi / start-vci end-vpi / end-vci</i> 	Configures the PVC or a range of PVCs and enters ATM virtual circuit subinterface mode or ATM range subinterface configuration mode.

	Command or Action	Purpose
	<p>Example:</p> <pre>Router(config-subif)# pvc cisco 0/5</pre> <p>Example:</p> <pre>or</pre> <p>Example:</p> <pre>Router(config-subif)# range range1 pvc 1/200 1/299</pre>	
Step 5	<p>encapsulation aal15snap</p> <p>Example:</p> <pre>Router(config-subif-atm-vc) # encapsulation aal15snap</pre> <p>Example:</p> <pre>or</pre> <p>Example:</p> <pre>Router(config-subif-atm-range) # encapsulation aal15snap</pre>	Configures LLC SNAP encapsulation on the PVC or a range of PVCs. ³
Step 6	<p>protocol ppp virtual-template <i>number</i></p> <p>Example:</p> <pre>Router(config-subif-atm-vc) # protocol ppp virtual-template 2</pre> <p>Example:</p> <pre>or</pre> <p>Example:</p> <pre>Router(config-subif-atm-range) # protocol ppp virtual-template 2</pre>	Configures IETF PPP over ATM LLC encapsulation on the PVC or a range of PVCs.
Step 7	<p>Do one of the following:</p> <ul style="list-style-type: none"> • end 	Exits ATM virtual circuit subinterface configuration mode. or

	Command or Action	Purpose
	<p>Example:</p> <pre>Router(config-subif-atm-vc) # end</pre> <p>Example: or</p> <p>Example:</p> <pre>Router(config-subif-atm-range) # end</pre>	Exits ATM range subinterface configuration mode.

² To determine the correct form of the interface atm command, consult your ATM shared port adapters documentation.

³ "SNAP encapsulation" is a misnomer here, since this encapsulation configures both LLC and SNAP encapsulation on the VC. If SNAP encapsulation is not configured at a lower inheritance level, or another type of encapsulation is configured at a lower inheritance level, you will have to configure both SNAP and the protocol ppp command to ensure that PPP over ATM with LLC encapsulation is configured on your VC.

Configuring IETF-Compliant LLC Encapsulated PPP over ATM on a Multipoint Subinterface

Multiple PVCs on multipoint subinterfaces significantly increase the maximum number of PPP-over-ATM sessions running on a Device.

Perform this task to configure IETF-compliant LLC encapsulated PPP over ATM PVC or a range of PVCs on a multipoint subinterface.

SUMMARY STEPS

1. **enable**
2. **configure terminal**
3. **interface atm** *number.subinterface-number* **multipoint**
4. Do one of the following:
 - **pvc** [*name*] *vpi* / *vci*
 -
 - **range** [*range-name*] **pvc** *start-vpi* / *start-vci* *end-vpi* / *end-vci*
5. **encapsulation aal5mux ppp virtual-template** *number*
6. **protocol ppp virtual-template** *number*
7. Do one of the following:
 - **end**

DETAILED STEPS

	Command or Action	Purpose
Step 1	<p>enable</p> <p>Example:</p> <pre>Device> enable</pre>	<p>Enables privileged EXEC mode.</p> <ul style="list-style-type: none"> • Enter your password if prompted.
Step 2	<p>configure terminal</p> <p>Example:</p> <pre>Device# configure terminal</pre>	<p>Enters global configuration mode.</p>
Step 3	<p>interface atm <i>number.subinterface-number</i> multipoint</p> <p>Example:</p> <pre>Device(config)# interface atm 1/0/0.4 multipoint</pre>	<p>Specifies the ATM multipoint subinterface using the appropriate form of the interface atm command⁴ and enters subinterface configuration mode.</p>
Step 4	<p>Do one of the following:</p> <ul style="list-style-type: none"> • pvc [<i>name</i>] <i>vpi</i> / <i>vci</i> • • range [<i>range-name</i>] pvc <i>start-vpi</i> / <i>start-vci</i> <i>end-vpi</i> / <i>end-vci</i> <p>Example:</p> <pre>Device(config-subif)# pvc cisco 0/5</pre> <p>Example:</p> <pre>or</pre> <p>Example:</p> <pre>Device(config-subif)# range range1 pvc 1/200 1/299</pre>	<p>Configures the PVC or a range of PVCs and enters ATM virtual circuit subinterface mode or ATM range subinterface configuration mode.</p>
Step 5	<p>encapsulation aal5mux ppp virtual-template <i>number</i></p> <p>Example:</p> <pre>Device(config-subif-atm-vc)# encapsulation aal5mux ppp virtual-template 3</pre> <p>Example:</p> <pre>or</pre>	<p>Configures VC multiplexed encapsulation on a PVC or PVC range.</p>

	Command or Action	Purpose
	<p>Example:</p> <pre>Device(config-subif-atm-range)# encapsulation aal5mux ppp virtual-template 3</pre>	
Step 6	<p>protocol ppp virtual-template <i>number</i></p> <p>Example:</p> <pre>Device(config-subif-atm-vc)# protocol ppp virtual-template 2</pre> <p>Example:</p> <p>or</p> <p>Example:</p> <pre>Device(config-subif-atm-range)# protocol ppp virtual-template 2</pre>	Configures IETF PPP over ATM LLC encapsulation on the PVC or a range of PVCs.
Step 7	<p>Do one of the following:</p> <ul style="list-style-type: none"> • end <p>Example:</p> <pre>Device(config-subif-atm-vc)# end</pre> <p>Example:</p> <p>Example:</p> <pre>Device(config-subif-atm-range)# end</pre>	<p>Exits ATM virtual circuit subinterface configuration mode.</p> <p>or</p> <p>Exits ATM range subinterface configuration mode.</p>

⁴ To determine the correct form of the interface atm command, consult your ATM shared port adapters documentation.

What to Do Next

You can also configure IETF-compliant LLC encapsulated PPP over ATM in a VC class and apply this VC class to an ATM VC, subinterface, or interface. For information about configuring a VC class, see the "Configuring VC Classes" section in the Configuring ATM module.

Configuration Examples for PPP over ATM

IETF-Compliant MUX Encapsulated PPP over ATM Configuration

This section provides the following examples for configuring IETF-compliant PPP over ATM:

Example: IETF-Compliant PPP over ATM with Different Traffic-Shaping Parameters

PVCs with different PPP-over-ATM traffic-shaping parameters can be configured on the same subinterface. In the following example, three PVCs are configured for PPP over ATM on subinterface ATM 2/0.1. PVC 0/60 is configured with IETF-compliant PPP over ATM encapsulation. Its traffic-shaping parameter is an unspecified bit rate with peak cell rate at 500 kb/s. PVC 0/70 is also configured with IETF-compliant PPP over ATM encapsulation, but its traffic-shaping parameter is nonreal-time variable bit rate, with peak cell rate at 1 Mb/s, sustainable cell rate at 500 kb/s, and burst cell size of 64 cells.

```
interface atm 2/0.1 multipoint
  pvc 0/60
    encapsulation aal5mux ppp virtual-template 3
   ubr 500
  exit
  pvc 0/70
    encapsulation aal5mux ppp virtual-template 3
    vbr-nrt 1000 500 64
  exit
```

Example: Two Routers with Back-to-Back PVCs

The figure below illustrates an ATM interface with two PPP sessions over two PVC session connections. The sample commands following the figure establish the back-to-back router configuration.

Figure 2: Two Routers with Back-to-Back PVCs

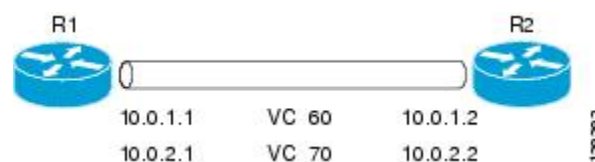

R1 Configuration

```
interface atm 2/0
  atm clock internal
  pvc 0/60
    encapsulation aal5mux ppp virtual-template 1
   ubr 90
  exit
  pvc 0/70
    encapsulation aal5mux ppp virtual-template 2
    vbr-nrt 90 50 1024
  exit
  interface virtual-template 1
  ip address 10.0.1.1 255.255.255.0
  interface virtual-template 2
```

```
ip address 10.0.2.1 255.255.255.0
exit
```

R2 Configuration

```
interface atm 2/0.1 multipoint
pvc 0/60
encapsulation aal5mux ppp virtual-template 1
ubr 90
exit
pvc 0/70
encapsulation aal5mux ppp virtual-template 2
vbr-nrt 90 50 1024
exit
exit
interface virtual-template 1
ip address 10.0.1.2 255.255.255.0
exit
interface virtual-template 2
ip address 10.0.2.2 255.255.255.0
```

Example: Multiplexed Encapsulation Using VC Class

In the following example, PVC 0/60 is configured on subinterface ATM 2/0.1 with a VC class attached to it. By rule of inheritance, PVC 0/60 runs with IETF-compliant PPP over ATM encapsulation using the configuration from interface virtual-template 1. Its parameter is an unspecified bit rate with peak cell at 90 kb/s.

```
interface atm 2/0/0.1
pvc 0/60
class-vc pvc-ppp
exit
exit
vc-class atm pvc-ppp
encapsulation aal5mux ppp virtual-template 1
ubr 90
exit
```

IETF-Compliant LLC Encapsulated PPP over ATM Configuration

This section provides the following examples for configuring IETF-compliant LLC encapsulated PPP over ATM:

Example: Configuring IETF-Compliant PPP over ATM LLC Encapsulation

This example shows how to configure IETF PPP over ATM LLC encapsulation in the VC class called ppp-default. The VC class specifies virtual template 1 from which to spawn PPP interfaces, SNAP encapsulation (the default), and a UBR class traffic type at 256 kb/s. When the VC class ppp-default is configured on interface 0.1, PVC 0/70 inherits these properties. PVC 0/80 overrides virtual template 1 in the VC class and uses virtual template 2 instead. PVC 0/90 also overrides virtual template 1 and uses virtual template 3 instead. In addition, PVC 0/90 uses a VC multiplexed encapsulation and a UBR class traffic type at 500 kb/s.

```
interface atm 2/0/0.1 multipoint
class-int ppp-default
!
pvc 0/70
exit
!
```

```

pvc 0/80
protocol ppp virtual-template 2
exit
!
pvc 0/90
encapsulation aal5mux ppp virtual-template 3
ubr 500
exit
exit
!
vc-class atm ppp-default
protocol ppp virtual-template 1
ubr 256
exit

```

Example: Overriding a Virtual Template for IETF-Compliant PPP over ATM

This example illustrates how to use inheritance to override a virtual template configuration for muxppp encapsulation options. For PVC 5/505 the encapsulation option at that level is cisco ppp virtual template 1, as specified in the VC class called muxppp, the **protocol ppp virtual-template 2** command overrides only the virtual-template configuration.

```

interface atm 2/0/0.1
class-int muxppp
!
pvc 5/505
protocol ppp virtual-template 2
exit
!
muxppp
encapsulation aal5mux ppp virtual-template 1
exit

```

Example: Disabling IETF-Compliant PPP over ATM LLC Encapsulation on a Specific VC

This example shows how to limit the configuration of a particular LLC encapsulated protocol to a particular VC. First, we see that the VC class called ppp is configured with IETF PPP over ATM with LLC encapsulation and virtual template 1. This VC class is then applied to ATM interface 1/0/0. By configuring SNAP encapsulation by itself on PVC 0/32, you disable IETF PPP over ATM with LLC encapsulation on this particular PVC; PVC 0/32 will only carry IP.

```

interface atm 1/0/0
class-int ppp
exit
!
interface atm 1/0/0.100 point-to-point
description IP only VC
ip address 10.1.1.1 255.255.255.0
pvc 0/32
encapsulation aal5snap
exit
exit
!
vc-class atm ppp
encapsulation aal5snap
protocol ppp virtual-template 1
exit

```

Additional References

Related Documents

Related Topic	Document Title
Cisco IOS commands	Cisco IOS Master Commands List, All Releases
Broadband and DSL commands	Cisco IOS Broadband and DSL Command Reference
Broadband access aggregation preparation tasks	Preparing for Broadband Access Aggregation
Configuring ATM	Configuring ATM

Standards/RFCs

Standards	Title
Frame Relay Forum standard FRF.8	<i>Frame Relay to ATM Internetworking</i>
RFC 2364	<i>PPP over AAL5</i>

Technical Assistance

Description	Link
The Cisco Support and Documentation website provides online resources to download documentation, software, and tools. Use these resources to install and configure the software and to troubleshoot and resolve technical issues with Cisco products and technologies. Access to most tools on the Cisco Support and Documentation website requires a Cisco.com user ID and password.	http://www.cisco.com/cisco/web/support/index.html

Feature Information for Providing Protocol Support for Broadband Access Aggregation of PPP over ATM Sessions

The following table provides release information about the feature or features described in this module. This table lists only the software release that introduced support for a given feature in a given software release train. Unless noted otherwise, subsequent releases of that software release train also support that feature.

Use Cisco Feature Navigator to find information about platform support and Cisco software image support. To access Cisco Feature Navigator, go to www.cisco.com/go/cfn. An account on Cisco.com is not required.

Table 6: Feature Information for Providing Protocol Support for Broadband Access Aggregation of PPP over ATM Sessions

Feature Name	Releases	Feature Configuration Information
PPP over ATM	Cisco IOS XE Release 3.3S Cisco IOS Release XE 3.14S	<p>PPP over ATM provides support for the termination of multiple PPP connections on an ATM interface of a router.</p> <p>In Cisco IOS XE Release 3.3S, this feature was introduced on the Cisco ASR 1000 Series Aggregation Services Routers.</p> <p>In Cisco IOS XE Release 3.14S, support for this feature was added on the Cisco 4451-X Integrated Services Router.</p> <p>The following commands were introduced or modified:</p> <p>encapsulation aal5mux ppp virtual-template , interface atm, protocol ppp virtual-template, pvc, range.</p>



Providing Connectivity Using ATM Routed Bridge Encapsulation over PVCs

The Providing Connectivity Using ATM Routed Bridge Encapsulation over PVCs feature provides the functionality of bridged ATM interface support to ATM switched virtual circuits (SVCs). Unlike permanent virtual circuits (PVCs), SVCs must be triggered by ongoing traffic and can be brought down when idle for some time. The SVCs are triggered, if down, and the traffic is passed on to the SVCs belonging to bridged ATM interface.

ATM routed bridge encapsulation (RBE) is used to route IP over bridged RFC 1483 Ethernet traffic from a stub-bridged LAN.

- [Finding Feature Information, page 71](#)
- [Prerequisites for Providing Connectivity Using ATM Routed Bridge Encapsulation over PVCs, page 72](#)
- [Restrictions for Providing Connectivity Using ATM Routed Bridge Encapsulation over PVCs, page 72](#)
- [Information About Providing Connectivity Using ATM Routed Bridge Encapsulation over PVCs, page 72](#)
- [How to Configure ATM Routed Bridge Encapsulation over PVCs, page 76](#)
- [Configuration Examples for Providing Connectivity Using ATM Routed Bridge Encapsulation, page 81](#)
- [Additional References, page 83](#)
- [Feature Information for Providing Connectivity Using ATM Routed Bridge Encapsulation, page 85](#)

Finding Feature Information

Your software release may not support all the features documented in this module. For the latest caveats and feature information, see [Bug Search Tool](#) and the release notes for your platform and software release. To find information about the features documented in this module, and to see a list of the releases in which each feature is supported, see the feature information table.

Use Cisco Feature Navigator to find information about platform support and Cisco software image support. To access Cisco Feature Navigator, go to www.cisco.com/go/cfn. An account on Cisco.com is not required.

Prerequisites for Providing Connectivity Using ATM Routed Bridge Encapsulation over PVCs

- When ATM SVCs are used, support for a form of bridging, such as integrated routing and bridging, is required.
- Before configuring connectivity from a remote bridged Ethernet network to a routed network using ATM routed bridge encapsulation, you must understand the concepts in the Understanding Broadband Access Aggregation module.

Restrictions for Providing Connectivity Using ATM Routed Bridge Encapsulation over PVCs

- Unlike PVCs, SVCs must be triggered by ongoing traffic and might be brought down after they have been idle for some time. The Bridged 1483 Encapsulated Traffic over ATM SVCs feature allows for the SVC to be triggered if down, and to pass the traffic on to the SVCs belonging to the bridged ATM interface.
- ATM RBE does not support MAC-layer access lists; only IP access lists are supported.

Information About Providing Connectivity Using ATM Routed Bridge Encapsulation over PVCs

Overview on Bridged 1483 Encapsulated Traffic over ATM SVCs

ATM RBE is used to route IP over bridged RFC 1483 Ethernet traffic from a stub-bridged LAN.

The figure below shows an ATM subinterface on a headend router that is configured to function in ATM routed-bridge encapsulation mode. This configuration is useful when a remote bridged Ethernet network

device needs connectivity to a routed network via a device bridging from an Ethernet LAN to an ATM RFC 1483 bridged encapsulation.

Figure 3: ATM Routed Bridge Encapsulation

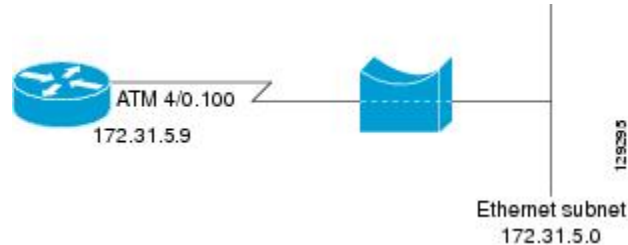

Because PVCs are statically configured along the entire path between the end systems, it would not be suitable to route bridged encapsulated traffic over them when the user wants to configure the virtual circuits (VCs) dynamically and tear down the VCs when there is no traffic.

ATM RBE Subinterface Grouping by PVC Range

You can configure ATM routed bridge encapsulation using an ATM PVC range rather than individual PVCs. When you configure a PVC range for routed bridge encapsulation, a point-to-point subinterface is created for each PVC in the range. The number of PVCs in a range can be calculated using the following formula:

$$\text{number of PVCs} = (\text{end-vpi} - \text{start-vpi} + 1) \times (\text{end-vci} - \text{start-vci} + 1)$$

Subinterface numbering begins with the subinterface on which the PVC range is configured and increases sequentially through the range.



Note

You cannot explicitly configure the individual point-to-point subinterfaces created by the PVC range on a point-to-point subinterface. All the point-to-point subinterfaces in the range share the same configuration as the subinterface on which the PVC range is configured.

DHCP Option 82 Support for RBE

The DHCP relay agent information option (option 82) enables a Dynamic Host Configuration Protocol (DHCP) relay agent to include information about itself when forwarding client-originated DHCP packets to a DHCP server. The DHCP server can use this information to implement IP address or other parameter-assignment policies.

The DHCP Option 82 Support for RBE feature provides support for the DHCP relay agent information option when ATM RBE is used. The figure below shows a typical network topology in which ATM RBE and DHCP are used. The aggregation router that is using ATM RBE is also serving as the DHCP relay agent.

Figure 4: Network Topology Using ATM RBE and DHCP

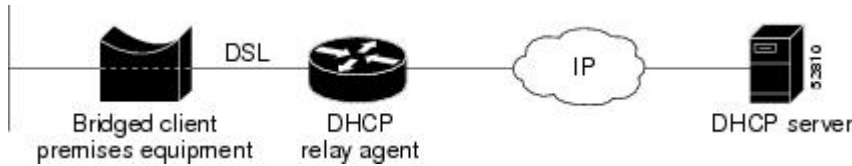

This feature communicates information to the DHCP server using a suboption of the DHCP relay agent information option called *agent remote ID*. The information sent in the agent remote ID includes an IP address identifying the relay agent and information about the ATM interface and the PVC over which the DHCP request came in. The DHCP server can use this information to make IP address assignments and security policy decisions.

The figure below shows the format of the agent remote ID suboption.

Figure 5: Format of the Agent Remote ID Suboption

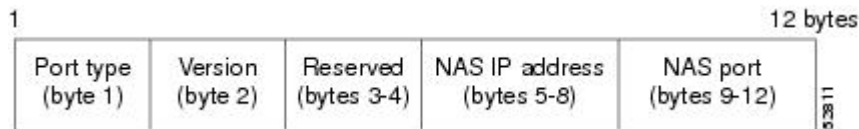

The table below describes the agent remote ID suboption fields displayed in the figure above.

Table 7: Agent Remote ID Suboption Field Descriptions

Field	Description
Port Type	Port type. The value 0x01 indicates RBE. (1 byte)
Version	Option 82 version. The value 0x01 specifies the RBE version of Option 82 (1 byte).
Reserved	RBE reserved (2 bytes).
NAS IP Address	One of the interfaces on the DHCP relay agent. The rbe nasip command can be used to specify which IP address will be used. (4 bytes)
NAS Port	RBE-enabled virtual circuit on which the DHCP request has come in. See the figure below for the format of this field. (4 bytes)

The figure below shows the format of the network access server (NAS) port field in the agent remote ID suboption.

Figure 6: Format of the NAS Port Field

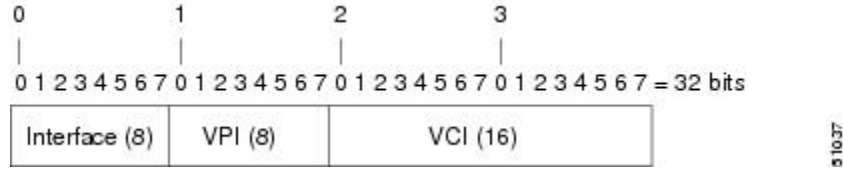

The figure below shows the format of the interface field. If there is no module, the value of the module bit is 0.

Figure 7: Format of the Interface Field



DHCP Lease Limit per ATM RBE Unnumbered Interface

The DHCP lease limit per ATM RBE Unnumbered Interface feature is enabled on a Cisco IOS DHCP relay agent connected to clients through unnumbered interfaces. The relay agent keeps information about the DHCP leases offered to the clients per subinterface. When a DHCPACK message is forwarded to the client, the relay agent increments the number of leases offered to clients on that subinterface. If a new DHCP client tries to obtain an IP address and the number of leases has already reached the configured lease limit, DHCP messages from the client will be dropped and will not be forwarded to the DHCP server.

If this feature is enabled on the Cisco IOS DHCP server directly connected to clients through unnumbered interfaces, the server allocates addresses and increments the number of leases per subinterface. If a new client tries to obtain an IP address, the server will not offer an IP address if the number of leases on the subinterface has already reached the configured lease limit.

Benefits of Providing Connectivity Using ATM Routed Bridge Encapsulation

Bridged IP packets received on an ATM interface configured in routed-bridge mode are routed via the IP header. Such interfaces take advantage of the characteristics of a stub LAN topology commonly used for digital subscriber line (DSL) access and offer increased performance and flexibility over integrated routing and bridging (IRB).

Another benefit of ATM RBE is that it reduces the security risk associated with normal bridging or IRB by reducing the size of the nonsecured network. By using a single VC allocated to a subnet (which could be as small as a single IP address), ATM RBE uses an IP address in the subnet to limit the "trust environment" to the premises of a single customer.

ATM RBE supports Cisco Express Forwarding (CEF), fast switching, and process switching.

The DHCP Option 82 Support for RBE feature enables those service providers to use DHCP to assign IP addresses and DHCP option 82 to implement security and IP address assignment policies.

The DHCP Lease Limit per ATM RBE Unnumbered Interface feature allows an Internet service provider (ISP) to globally limit the number of leases available to clients per household or connection.

How to Configure ATM Routed Bridge Encapsulation over PVCs

Configuring ATM Routed Bridge Encapsulation Using PVCs

Perform the following task to configure ATM RBE using PVCs. Only the specified network layer (IP) is routed. Any remaining protocols can be passed on to bridging or other protocols. In this manner, ATM RBE can be used to route IP, while other protocols (such as IPX) are bridged normally.

or

show ip cache verbose

SUMMARY STEPS

1. **enable**
2. **configure terminal**
3. **interface atm slot / 0 . subinterface-number point-to-point**
4. Do one of the following:
 - **pvc vpi /vci**
 -
 - **range [range-name] pvc start-vpi / start-vci end-vpi / end-vci**
5. **exit**
6. **ip address ip-address mask [secondary]**
7. **end**
8. Do one of the following:
 - **show arp**
 - or
 - **show ip cache verbose**

DETAILED STEPS

	Command or Action	Purpose
Step 1	enable Example: Router> enable	Enables privileged EXEC mode. • Enter your password if prompted.

	Command or Action	Purpose
Step 2	configure terminal Example: <pre>Router# configure terminal</pre>	Enters global configuration mode.
Step 3	interface atm slot / 0 . subinterface-number point-to-point Example: <pre>Router(config)# interface atm 5/0.5 point-to-point</pre>	Specifies an ATM point-to-point subinterface and enters subinterface mode.
Step 4	Do one of the following: <ul style="list-style-type: none"> • pvc vpi /vci • • range [range-name] pvc start-vpi / start-vci end-vpi / end-vci Example: <pre>Router(config-subif)# pvc 0/32</pre> Example: <pre>Router(config-subif)# range range1 pvc 1/200 1/299</pre>	Configures a PVC to carry the routed bridge traffic and enters ATM VC class configuration mode. Configures a range of PVCs to carry the routed bridge traffic and enters ATM PVC range configuration mode.
Step 5	exit Example: <pre>Router(config-if-atm-vc)# exit</pre>	Exits to subinterface configuration mode.
Step 6	ip address ip-address mask [secondary] Example: <pre>Router(config-subif)# ip address 209.165.200.224 255.255.255.0</pre>	Provides an IP address on the same subnetwork as the remote network.
Step 7	end Example: <pre>Router(config-subif)# end</pre>	Exits to privileged EXEC mode.
Step 8	Do one of the following: <ul style="list-style-type: none"> • show arp 	(Optional) Displays ATM RBE configuration information.

	Command or Action	Purpose
	<ul style="list-style-type: none"> • or • show ip cache verbose <p>Example:</p> <pre>Router# show arp</pre> <p>Example:</p> <pre>Router# show ip cache verbose</pre>	

Examples

To confirm that ATM RBE is enabled, use the **show arp** command and the **show ip cache verbose** command in privileged EXEC mode:

```
Router# show arp

Protocol Address      Age (min)  Hardware Addr  Type   Interface
Internet 209.165.201.51    6          0001.c9f2.a81d ARPA   Ethernet3/1
Internet 209.165.201.49    -          0060.0939.bb55 ARPA   Ethernet3/1
Internet 209.165.202.128  30         0010.0ba6.2020 ARPA   Ethernet3/0
Internet 209.165.201.52    6          00e0.1e8d.3f90 ARPA   ATM1/0.4
Internet 209.165.201.53    5          0007.144f.5d20 ARPA   ATM1/0.2
Internet 209.165.202.129  -          0060.0939.bb54 ARPA   Ethernet3/0
Internet 209.165.201.125  30         00b0.c2e9.bc55 ARPA   Ethernet3/1#

Router# show ip cache verbose
IP routing cache 3 entries, 572 bytes
  9 adds, 6 invalidates, 0 refcounts
Minimum invalidation interval 2 seconds, maximum interval 5 seconds,
  quiet interval 3 seconds, threshold 0 requests
Invalidation rate 0 in last second, 0 in last 3 seconds
Last full cache invalidation occurred 00:30:34 ago
Prefix/Length      Age      Interface Next Hop
209.165.201.51/32-24 00:30:10 Ethernet3/1 10.1.0.51 14 0001C9F2A81D00600939 BB550800
209.165.202.129/32-24 00:00:04 ATM1/0.2 10.8.100.50 28
00010000AAAA030080C2000700000007144F5D2000600939 BB1C0800
209.165.201.125/32-24 00:06:09 ATM1/0.4 10.8.101.35 28
00020000AAAA030080C20007000000E01E8D3F9000600939 BB1C0800
```

Configuring DHCP Option 82 for RBE

Perform this task to configure the DHCP Option 82 Support for RBE feature.

Before You Begin

DHCP option 82 support must be configured on the DHCP relay agent using the **ip dhcp relay information option** command before you can use the DHCP Option 82 Support for RBE feature.

SUMMARY STEPS

1. **enable**
2. **configure terminal**
3. **ip dhcp relay information option**
4. **rbe nasip *source-interface***
5. **end**

DETAILED STEPS

	Command or Action	Purpose
Step 1	enable Example: Router> enable	Enables privileged EXEC mode. <ul style="list-style-type: none"> • Enter your password if prompted.
Step 2	configure terminal Example: Router# configure terminal	Enters global configuration mode.
Step 3	ip dhcp relay information option Example: Router(config)# ip dhcp relay information option	Enables the DHCP option 82 support on relay agent. <ul style="list-style-type: none"> • Enabling the DHCP option 82 support allows the system to insert the DHCP relay agent information option in forwarded BOOT REQUEST messages to a Cisco IOS DHCP server.
Step 4	rbe nasip <i>source-interface</i> Example: Router(config)# rbe nasip loopback0	Specifies the IP address of an interface on the DHCP relay agent that will be sent to the DHCP server via the Agent Remote ID suboption.
Step 5	end Example: Router(config)# end	Exits global configuration mode and enters privileged configuration mode.

Configuring the DHCP Lease Limit

Perform this task to limit the number of DHCP leases allowed on ATM RBE unnumbered or serial unnumbered interfaces.

SUMMARY STEPS

1. **enable**
2. **configure terminal**
3. **ip dhcp limit lease per interface** *lease-limit*
4. **end**

DETAILED STEPS

	Command or Action	Purpose
Step 1	enable Example: Router> enable	Enables privileged EXEC mode. <ul style="list-style-type: none"> • Enter your password if prompted.
Step 2	configure terminal Example: Router# configure terminal	Enters global configuration mode.
Step 3	ip dhcp limit lease per interface <i>lease-limit</i> Example: Router(config)# ip dhcp limit lease per interface 2	Limits the number of leases offered to DHCP clients behind an ATM RBE unnumbered or serial unnumbered interface.
Step 4	end Example: Router(config)# end	Exits global configuration mode and returns to privileged EXEC mode.

Troubleshooting the DHCP Lease Limit

Perform this task to troubleshoot the DHCP lease limit.

SUMMARY STEPS

1. **enable**
2. **debug ip dhcp server packet**
3. **debug ip dhcp server events**

DETAILED STEPS

	Command or Action	Purpose
Step 1	enable Example: Router> enable	Enables privileged EXEC mode. <ul style="list-style-type: none"> • Enter your password if prompted.
Step 2	debug ip dhcp server packet Example: Router# debug ip dhcp server packet	(Optional) Decodes DHCP receptions and transmissions.
Step 3	debug ip dhcp server events Example: Router(config)# debug ip dhcp server events	(Optional) Displays server events.

Configuration Examples for Providing Connectivity Using ATM Routed Bridge Encapsulation

The following examples show various ways to provide connectivity from a remote bridged network to a routed network using ATM RBE.

Example Configuring ATM RBE on PVCs

The following example shows a typical ATM routed bridge encapsulation configuration:

```
enable
configure terminal
interface atm 4/0.100 point-to-point
ip address 209.165.200.225 255.255.255.224
pvc 0/32
end
```

Example Configuring ATM RBE on an Unnumbered Interface

The following example uses a static route to point to an unnumbered interface:

```
enable
configure terminal
interface loopback 0
ip address 209.165.200.226 255.255.255.224
interface atm 4/0.100 point-to-point
```

```

ip unnumbered loopback 0
pvc 0/32
  atm route-bridge ip
  exit
ip route 209.165.200.228 255.255.255.224 atm 4/0.100
end

```

Example Concurrent Bridging and ATM RBE

The following example shows concurrent use of ATM RBE with normal bridging. IP datagrams are route-bridged, and other protocols (such as IPX or AppleTalk) are bridged.

```

bridge 1 protocol ieee
interface atm 4/0.100 point-to-point
  ip address 209.165.200.225 255.255.255.224
  pvc 0/32
  bridge-group 1
  atm route-bridge ip

```

Example DHCP Option 82 for RBE Configuration

In the following example, DHCP option 82 support is enabled on the DHCP relay agent using the **ip dhcp relay information option** command. The **rbe nasip** command configures the router to forward the IP address for Loopback0 to the DHCP server.

```

ip dhcp-server 209.165.200.225
!
ip dhcp relay information option
!
interface Loopback0
  ip address 209.165.201.0 255.255.255.248
!
interface atm 4/0
  no ip address
!
interface atm 4/0.1 point-to-point
  ip unnumbered Loopback0
  ip helper-address 209.165.201.3
  atm route-bridged ip
  pvc 88/800
  encapsulation aal5snap
!
!
interface Ethernet5/1
  ip address 209.165.201.4 255.255.255.248
!
router eigrp 100
  network 209.165.201.0
  network 209.165.200.0
!
rbe nasip Loopback0

```

For the configuration example, the value (in hexadecimal) of the agent remote ID suboption would be 010100000B01018140580320. The table below shows the value of each field within the agent remote ID suboption.

Table 8: Agent Remote ID Suboption Field Values

Agent Remote ID Suboption Field	Value
Port Type	0x01

Agent Remote ID Suboption Field	Value
Version	0x01
Reserved	undefined
NAS IP Address	0x0B010181 (hexadecimal value of 11.1.1.129)
NAS Port <ul style="list-style-type: none"> • Interface (slot/module/port) • VPI • VCI 	<ul style="list-style-type: none"> • 0x40 (The slot/module/port values are 0100/0/000.) • 0x58 (hexadecimal value of 88) • 0x320 (hexadecimal value of 800)

Example DHCP Lease Limit

In the following example, if more than three clients try to obtain an IP address from interface ATM4/0.1, the DHCPDISCOVER packets will not be forwarded to the DHCP server. If the DHCP server resides on the same router, DHCP will not reply to more than three clients.

```
ip dhcp limit lease per interface 3
!
interface loopback0
 ip address 209.165.201.3 255.255.255.248
!
interface atm 4/0.1
 no ip address
!
interface atm 4/0.1 point-to-point
 ip helper-address 172.16.1.2
 ip unnumbered loopback0
 atm route-bridged ip
  pvc 88/800
  encapsulation aal5snap
```

Additional References

Related Documents

Related Topic	Document Title
Cisco IOS commands	Cisco IOS Master Commands List, All Releases
Broadband Access Aggregation and DSL commands	<i>Cisco IOS Broadband Access Aggregation and DSL Command Reference</i>
Broadband access aggregation concepts	Understanding Broadband Access Aggregation
Preparing for broadband access aggregation task	Preparing for Broadband Access Aggregation

Related Topic	Document Title
DHCP commands	<i>Cisco IOS IP Addressing Services Command Reference</i>
DHCP configuration tasks	"Configuring the Cisco IOS DHCP Server" module in the <i>Cisco IOS IP Addressing Services Configuration Guide</i>

Standards

Standards	Title
None	--

MIBs

MIBs	MIBs Link
None	To locate and download MIBs for selected platforms, Cisco software releases, and feature sets, use Cisco MIB Locator found at the following URL: http://www.cisco.com/go/mibs

RFCs

RFCs	Title
None	--

Technical Assistance

Description	Link
<p>The Cisco Support website provides extensive online resources, including documentation and tools for troubleshooting and resolving technical issues with Cisco products and technologies.</p> <p>To receive security and technical information about your products, you can subscribe to various services, such as the Product Alert Tool (accessed from Field Notices), the Cisco Technical Services Newsletter, and Really Simple Syndication (RSS) Feeds.</p> <p>Access to most tools on the Cisco Support website requires a Cisco.com user ID and password.</p>	<p>http://www.cisco.com/cisco/web/support/index.html</p>

Feature Information for Providing Connectivity Using ATM Routed Bridge Encapsulation

The following table provides release information about the feature or features described in this module. This table lists only the software release that introduced support for a given feature in a given software release train. Unless noted otherwise, subsequent releases of that software release train also support that feature.

Use Cisco Feature Navigator to find information about platform support and Cisco software image support. To access Cisco Feature Navigator, go to www.cisco.com/go/cfn. An account on Cisco.com is not required.

Table 9: Feature Information for Providing Connectivity Using ATM Routed Bridge Encapsulation

Feature Name	Releases	Feature Information
Bridged 1483 Encapsulated Traffic over ATM SVCs	12.4(15)T 12.2(33)SRE	The Bridged 1483 Encapsulated Traffic over ATM SVCs feature provides support for bridged 1483 encapsulated packets to trigger ATM SVC and also support for sending this traffic on triggered ATM SVCs.
DHCP Option 82 Support for Routed Bridge Encapsulation	15.1(1)S 12.2(2)T	This feature provides support for the DHCP relay agent information option when ATM RBE is used. The following command was introduced: rbe nasip

Feature Name	Releases	Feature Information
DHCP Lease Limit per ATM RBE Unnumbered Interface	12.3(2)T	<p>This feature limits the number of DHCP leases per subinterface offered to DHCP clients connected from an ATM RBE unnumbered interface or serial unnumbered interface of the DHCP server or DHCP relay agent.</p> <p>The following command was introduced: ip dhcp limit lease per interface</p>



PPPoE Circuit-Id Tag Processing

The PPPoE Circuit-Id Tag Processing feature provides a way to extract a Circuit-Id tag from the digital subscriber line (DSL) as an identifier for the authentication, authorization, and accounting (AAA) access request on a Fast Ethernet or Gigabit Ethernet interface, thereby simulating ATM-based Broadband access, but using cost-effective Fast Ethernet or Gigabit Ethernet instead. The tag is useful for troubleshooting the network, and is also used in RADIUS authentication and accounting processes.

- [Finding Feature Information, page 87](#)
- [Prerequisites for the PPPoE Circuit-Id Tag Processing Feature, page 87](#)
- [Information About the PPPoE Circuit-Id Tag Processing Feature, page 88](#)
- [How to Configure the PPPoE Circuit-Id Tag Processing Feature, page 90](#)
- [Configuration Examples for the PPPoE Circuit-Id Tag Processing Feature, page 93](#)
- [Additional References, page 94](#)
- [Feature Information for PPPoE Circuit-Id Tag Processing, page 95](#)

Finding Feature Information

Your software release may not support all the features documented in this module. For the latest caveats and feature information, see [Bug Search Tool](#) and the release notes for your platform and software release. To find information about the features documented in this module, and to see a list of the releases in which each feature is supported, see the feature information table.

Use Cisco Feature Navigator to find information about platform support and Cisco software image support. To access Cisco Feature Navigator, go to www.cisco.com/go/cfn. An account on Cisco.com is not required.

Prerequisites for the PPPoE Circuit-Id Tag Processing Feature

It is recommended that you be familiar with RFC 2516 before configuring this feature.

Information About the PPPoE Circuit-Id Tag Processing Feature

Differences Between ATM- and Fast or Gigabit Ethernet-Based Broadband Access Networks

Broadband digital subscriber line multiplexer (DSLAM) and Broadband Remote Access Server (BRAS) vendors see a need to provide Fast or Gigabit Ethernet-based networks as an alternative to an ATM access network, with a DSLAM bridging the ATM-DSL local loop to the Fast or Gigabit Ethernet-based access network and allowing Fast or Gigabit Ethernet-based connectivity to the BRAS. But in an Fast or Gigabit Ethernet access network, there is no unique mapping between the subscriber Line-Id and the interface, as is found in an ATM-based network. In an ATM-based network, the ATM VC is associated to a subscriber line.

During the authentication phase that initiates the PPP access and AAA accounting requests, the BRAS includes a NAS-Port-Id attribute in RADIUS authentication packets, if the feature "TAL based on the NAS-Port-Id" feature is configured. This attribute identifies the DSL line for the subscriber. See [Configuring BRAS to Include a NAS-Port-Id Attribute Example](#), on page 94 for an example.

DSL Forum 2004-71 Solution

To apply the same subscriber mapping capability to Fast or Gigabit Ethernet interfaces that is possible on ATM interfaces, DSL Forum 2004-71 proposes a solution whereby the DSLAM sends the DSL Line-Id in the PPP over Ethernet (PPPoE) discovery phase. This method provides a way for a PPPoE server acting as a BRAS to extract the Line-Id tag and use the Circuit-Id field of that tag as a NAS-Port-Id attribute in AAA access and accounting requests. The PPPoE Circuit-Id Tag Processing feature makes use of the proposed DSL Forum 2004-71 method and allows the BRAS to detect the presence of the subscriber Circuit-Id tag inserted by the DSLAM during the PPPoE discovery phase. The BRAS will send this tag as a NAS-Port-Id attribute in PPP authentication and AAA accounting requests. The tag is useful in troubleshooting the Ethernet network, and it is also used in RADIUS authentication and accounting processes.

Approach for a Circuit-Id Tag in Ethernet-Based Broadband Access Networks

Traditional ATM-based DSL broadband access networks have the topology shown in the figure below.

Figure 8: ATM-Based DSL Broadband Access Network

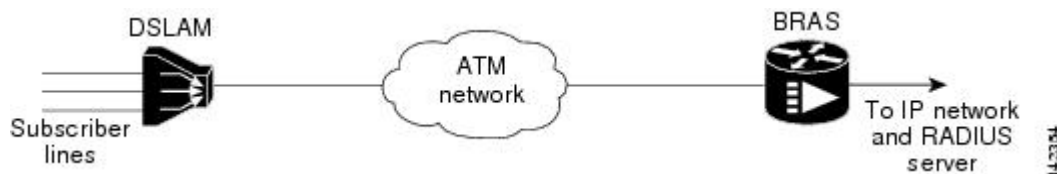

In terms of logical connectivity, there is a one-to-one mapping of the DSL subscriber line to the end user and the ATM VC used to carry the PPP session through the DSLAM and to the BRAS, where this VC information is converted into a NAS-Port-Id for use in RADIUS packets.

The simple mapping available from an ATM-based network between the physical line in the DSL local loop to the end user and a VC (from DSLAM to BRAS) is not available for an Fast or Gigabit Ethernet-based network. To solve this problem, the PPPoE Circuit-Id Tag Processing feature uses a PPPoE intermediate agent function on the DSLAM to attach a tag to the PPPoE discovery packets. The BRAS then receives the tagged packet, decodes the tag, and inserts the line identifier into RADIUS packets destined for the RADIUS server.

DSLAM intercepts PPPoE discovery frames from the client and inserts a unique line identifier (circuit-id) using the PPPoE Vendor-Specific tag (0x0105) to PPPoE Active Discovery Initiation and Request (PADI and PADR) packets; see the figure below. The DSLAM forwards these packets to the BRAS after the insertion. The tag contains the circuit-id of the DSL line on which the PADI or PADR packet was received, in the access node where the intermediate agent resides.

Figure 9: PPPoE Circuit-Id Tag Processing Solution

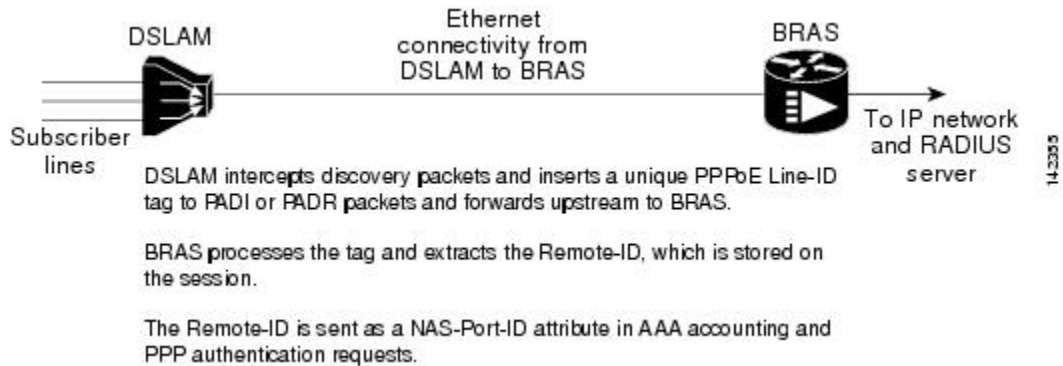

When the **vendor-tag circuit-id service** command is configured in BBA (broadband access) group configuration mode, the BRAS processes the received PPPoE Vendor-Specific tag in the PADR packet and extracts the Circuit-Id field, which is sent to the remote AAA server as the NAS-Port-Id attribute (RADIUS attribute 87) in RADIUS access and accounting requests. When the **radius-server attribute nas-port format d** global configuration command is also configured on the BRAS, the Acct-Session-Id attribute will contain the information about the incoming access interface, where discovery frames are received, and about the session being established.

Outgoing PAD Offer and Session-confirmation (PADO and PADS) packets from the BRAS will have the DSLAM-inserted Circuit-Id tag. DSLAM should strip the tag out of PADO and PADS packets. If the DSLAM cannot strip off the tag, the BRAS should remove it before sending the packets out, and this is accomplished using the **vendor-tag circuit-id strip** BBA group configuration mode command.

Benefits of the PPPoE Circuit-Id Tag Processing Feature

The shift towards Fast or Gigabit Ethernet-based DSLAMs offers the following benefits:

- Ability to use simpler and lower cost provisioning options for DSL subscribers over an Fast or Gigabit Ethernet-based backhaul network rather than on an ATM-based network.
- Ability to use higher bandwidth connectivity options available from Fast or Gigabit Ethernet not possible on ATM.
- Ability to upgrade to next-generation DSLAMs with quality of service (QoS), and support for higher bandwidth, asymmetric dual latency modems such as the ADSL2.

- Ability to inject high-bandwidth content such as video in an Ethernet network.

How to Configure the PPPoE Circuit-Id Tag Processing Feature

Configuring the PPPoE Circuit-Id Tag Processing Feature

This section describes how to configure an Fast or Gigabit Ethernet-based access network on a Cisco BRAS. The extracted Circuit-Id tag (see [Information About the PPPoE Circuit-Id Tag Processing Feature, on page 88](#)) is sent in the following RADIUS syntax, as recommended by the DSL Forum:

"Access-Node-Identifier eth *slot/port* [:*vlan-tag*]"

The Access-Node-Identifier is a unique subscriber identifier or telephone number text string entered without spaces. Per DSL-Forum 2004-71, the maximum length supported for the tag is 48 bytes. The BRAS copies the entire tag into the NAS-Port-Id and sends it to the AAA server.

SUMMARY STEPS

1. **enable**
2. **configure terminal**
3. **radius-server attribute nas-port format d**
4. **bba-group pppoe *group-name***
5. **vendor-tag circuit-id service**

DETAILED STEPS

	Command or Action	Purpose
Step 1	enable Example: Router> enable	Enables privileged EXEC mode. • Enter your password if prompted.
Step 2	configure terminal Example: Router# configure terminal	Enters global configuration mode.
Step 3	radius-server attribute nas-port format d Example: Router(config)# radius-server attribute nas-port format d	(Optional) Selects the PPPoE extended NAS-Port format used for RADIUS access and accounting. • Configure this command so that the Acct-Session-Id attribute, as displayed in the debug radius command, will contain the information about the incoming access interface, where discovery frames are received, and about the session being established. See the Displaying the Session Activity Log, on page 92 and

	Command or Action	Purpose
		Configuring PPPoE Circuit-Id Tag Processing Example , on page 93 sections for more information.
Step 4	<p>bba-group pppoe <i>group-name</i></p> <p>Example:</p> <pre>Router(config-bba-group)# bba-group pppoe pppoe-group</pre>	Defines a PPPoE profile.
Step 5	<p>vendor-tag circuit-id service</p> <p>Example:</p> <pre>Router(config-bba-group)# vendor-tag circuit-id service</pre>	Enables processing of the received PPPoE Vendor-Specific tag in the PADR packet, which extracts the Circuit-Id part of the tag and sends it to the AAA server as the NAS-Port-Id attribute in RADIUS access and accounting requests.

Removing the PPPoE Circuit-Id Tag

Outgoing PADO and PADS packets will have the DSLAM-inserted Vendor-Specific Line-Id tag, and DSLAM must strip the Circuit-Id tag from the packets. If the DSLAM cannot strip the tag, the BRAS must remove it before sending out the packets. This task is accomplished through configuration of the **vendor-tag circuit-id strip** command in BBA group configuration mode.

SUMMARY STEPS

1. **enable**
2. **configure terminal**
3. **bba-group pppoe** *group-name*
4. **vendor-tag strip**

DETAILED STEPS

	Command or Action	Purpose
Step 1	<p>enable</p> <p>Example:</p> <pre>Router> enable</pre>	<p>Enables privileged EXEC mode.</p> <ul style="list-style-type: none"> • Enter your password if prompted.

	Command or Action	Purpose
Step 2	configure terminal Example: Router# configure terminal	Enters global configuration mode.
Step 3	bba-group pppoe group-name Example: Router(config)# bba-group pppoe pppoe-group	Defines a PPPoE profile and enters BBA group configuration mode.
Step 4	vendor-tag strip Example: Router(config-bba-group)# vendor-tag strip	Enables the BRAS to strip off incoming Vendor-Specific Circuit-Id tags from outgoing PADO and PADS packets.

Displaying the Session Activity Log

When the **radius-server attribute nas-port format d** global configuration command is added to the PPPoE Circuit-Id Tag Processing feature configuration on the BRAS (see the [Configuring PPPoE Circuit-Id Tag Processing Example, on page 93](#) for an example), the report from the **debug radius** privileged EXEC command will include information about the incoming access interface, where discovery frames are received, and about the session being established in PPPoE extended NAS-Port format (format d).

Enable the **debug radius** command to display a report of session activity. In the example shown in this section:

- The `acct_session_id` is 79 or 4F in hexadecimal format.
- In the message "Acct-session-id pre-pended with Nas Port = 0/0/200," the interface on which the PPPoE discovery frames arrived is FastEthernet0/0.200. The 0/0/0 is Cisco format for slot/subslot/port.
- The Acct-Session-Id vendor-specific attribute 44 contains the string "0/0/0/200_0000004F," which is a combination of the ingress interface and the session identifier.



Note Strings of interest in the **debug radius** output log are presented in bold text for example purposes only.

```
Router# debug radius
02:10:49: RADIUS(0000003F): Config NAS IP: 0.0.0.0
02:10:49: RADIUS/ENCODE(0000003F): acct_session_id: 79
02:10:49: RADIUS(0000003F): sending
02:10:49: RADIUS/ENCODE: Best Local IP-Address 10.0.58.141 for Radius-Server 172.20.164.143
02:10:49: RADIUS(0000003F): Send Access-Request to 172.20.164.143:1645 id 1645/65, len 98
02:10:49: RADIUS: authenticator 1C 9E B0 A2 82 51 C1 79 - FE 24 F4 D1 2F 84 F5 79
02:10:49: RADIUS: Framed-Protocol [7] 6 PPP [1]
02:10:49: RADIUS: User-Name [1] 7 "peer1"
02:10:49: RADIUS: CHAP-Password [3] 19 *
```

```

02:10:49: RADIUS: NAS-Port-Type [61] 6 Ethernet [15]
02:10:49: RADIUS: NAS-Port [5] 6 200
02:10:49: RADIUS: NAS-Port-Id [87] 22 "FastEthernet6/0.200:"
02:10:49: RADIUS: Service-Type [6] 6 Framed [2]
02:10:49: RADIUS: NAS-IP-Address [4] 6 10.0.58.141
02:10:49: RADIUS: Received from id 1645/65 172.20.164.143:1645, Access-Accept, len 32
02:10:49: RADIUS: authenticator 06 45 84 1B 27 1F A5 C3 - C3 C9 69 6E B9 C0 6F 94
02:10:49: RADIUS: Service-Type [6] 6 Framed [2]
02:10:49: RADIUS: Framed-Protocol [7] 6 PPP [1]
02:10:49: RADIUS(0000003F): Received from id 1645/65
02:10:49: [62]PPPoE 65: State LCP_NEGOTIATION Event PPP_LOCAL
02:10:49: PPPoE 65/SB: Sent vtemplate request on base Vi2
02:10:49: [62]PPPoE 65: State VACCESS_REQUESTED Event VA_RESP
02:10:49: [62]PPPoE 65: Vi2.1 interface obtained
02:10:49: [62]PPPoE 65: State PTA_BINDING Event STAT_BIND
02:10:49: [62]PPPoE 65: data path set to Virtual Access
02:10:49: [62]PPPoE 65: Connected PTA
02:10:49: [62]PPPoE 65: AAA get dynamic attrs
02:10:49: [62]PPPoE 65: AAA get dynamic attrs
02:10:49: RADIUS/ENCODE(0000003F):Orig. component type = Ppoe
02:10:49: RADIUS/ENCODE(0000003F) : Acct-session-id pre-pended with Nas Port = 0/0/200
02:10:49: RADIUS(0000003F): Config NAS IP: 0.0.0.0
02:10:49: RADIUS(0000003F): sending
02:10:49: RADIUS/ENCODE: Best Local IP-Address 10.0.58.141 for Radius-Server 172.20.164.143
02:10:49: RADIUS(0000003F): Send Accounting-Request to 172.20.164.143:1646 id 1 646/42, len
117
02:10:49: RADIUS: authenticator 57 24 38 1A A3 09 62 42 - 55 2F 41 71 38 E1 CC 24
02:10:49: RADIUS: Acct-Session-Id [44] 20 "0/0/200_0000004F"
02:10:49: RADIUS: Framed-Protocol [7] 6 PPP [1]
02:10:49: RADIUS: User-Name [1] 7 "peer1"
02:10:49: RADIUS: Acct-Authentic [45] 6 RADIUS [1]
02:10:49: RADIUS: Acct-Status-Type [40] 6 Start [1]
02:10:49: RADIUS: NAS-Port-Type [61] 6 Ethernet [15]
02:10:49: RADIUS: NAS-Port [5] 6 200
02:10:49: RADIUS: NAS-Port-Id [87] 22 "FastEthernet6/0.200:"
02:10:49: RADIUS: Service-Type [6] 6 Framed [2]
02:10:49: RADIUS: NAS-IP-Address [4] 6 10.0.58.141
02:10:49: RADIUS: Acct-Delay-Time [41] 6 0
02:10:49: RADIUS: Received from id 1646/42 172.20.164.143:1646, Accounting-resp onse, len
20
02:10:49: RADIUS: authenticator 34 84 7E B2 F4 40 B2 7C - C5 B2 4E 98 78 03 8B C0

```

Configuration Examples for the PPPoE Circuit-Id Tag Processing Feature

Configuring PPPoE Circuit-Id Tag Processing Example

In the following example, outgoing PADO and PADS packets will retain the incoming Vendor-Specific Circuit-Id tag:

```

radius-server attribute nas-port format d
!
bba-group pppoe pppoe-group
sessions per-mac limit 50
vendor-tag circuit-id service
!
interface FastEthernet0/0.1
encapsulation dot1Q 120
pppoe enable group pppoe-group

```

Configuring BRAS to Include a NAS-Port-Id Attribute Example

In the following example, the feature TAL based on the NAS-Port-Id is configured. This configuration ensures that a NAS-Port-Id attribute is included in RADIUS authentication packets during the authentication phase to initiate PPP access and AAA accounting requests.

```
radius-server attribute nas-port
policy-map type control test
  class type control always event session-start
  1 authorize identifier nas-port
```

Removing the PPPoE Circuit-Id Tag Example

In the following example, the BRAS will strip off incoming Vendor-Specific Circuit-Id tags from outgoing PADO and PADS packets:

```
bba-group pppoe pppoe-rm-tag
  sessions per-mac limit 50
  vendor-tag circuit-id service
  vendor-tag strip
interface FastEthernet0/0.1
  encapsulation dot1Q 120
  pppoe enable group pppoe-group
```

Additional References

The following sections provide references related to the PPPoE Circuit-Id Tag Processing feature.

Related Documents

Related Topic	Document Title
Configuring Broadband and DSL	<i>Cisco IOS XE Broadband Access Aggregation and DSL Configuration Guide</i>
RADIUS attributes	<i>Cisco IOS XE Security Configuration Guide</i>
DSL Forum Line-Id tag solution	Broadband Forum

Standards

Standard	Title
None	--

MIBs

MIB	MIBs Link
None	To locate and download MIBs for selected platforms, Cisco IOS XE software releases, and feature sets, use Cisco MIB Locator found at the following URL: http://www.cisco.com/go/mibs

RFCs

RFC	Title
RFC 2516	A Method for Transmitting PPP over Ethernet (PPPoE)

Technical Assistance

Description	Link
<p>The Cisco Support website provides extensive online resources, including documentation and tools for troubleshooting and resolving technical issues with Cisco products and technologies.</p> <p>To receive security and technical information about your products, you can subscribe to various services, such as the Product Alert Tool (accessed from Field Notices), the Cisco Technical Services Newsletter, and Really Simple Syndication (RSS) Feeds.</p> <p>Access to most tools on the Cisco Support website requires a Cisco.com user ID and password.</p>	http://www.cisco.com/techsupport

Feature Information for PPPoE Circuit-Id Tag Processing

The following table provides release information about the feature or features described in this module. This table lists only the software release that introduced support for a given feature in a given software release train. Unless noted otherwise, subsequent releases of that software release train also support that feature.

Use Cisco Feature Navigator to find information about platform support and Cisco software image support. To access Cisco Feature Navigator, go to www.cisco.com/go/cfn. An account on Cisco.com is not required.

Table 10: Feature Information for PPPoE Circuit-Id Tag Processing

Feature Name	Releases	Feature Information
PPPoE Circuit-Id Tag Processing	Cisco IOS XE Release 2.1.	<p>The PPPoE Circuit-Id Tag Processing feature provides a way to extract a Circuit-Id tag from the DSL as an identifier for the AAA access request on an Ethernet interface, thereby simulating ATM-based broadband access, but using cost-effective Ethernet instead. The tag is useful for troubleshooting the network, and is also used in RADIUS authentication and accounting processes.</p> <p>This feature was introduced on Cisco ASR 1000 Series Aggregation Services Routers.</p> <p>This feature was integrated into Cisco IOS XE Release 2.3.1.</p> <p>The following commands were introduced or modified: vendor-tag circuit-id service, vendor-tag strip.</p>



Configuring PPP over Ethernet Session Limit Support

This module provides information on how to limit the number of PPP over Ethernet (PPPoE) sessions that can be created on a router or on a Gigabit Ethernet interface for configuration.

- [Finding Feature Information, page 97](#)
- [Information About Configuring PPP over Ethernet Session Limit Support, page 98](#)
- [How to Configure PPP over Ethernet Session Limit Support, page 98](#)
- [Configuration Examples for PPP over Ethernet Session Limit Support, page 103](#)
- [Additional References, page 104](#)
- [Feature Information for Configuring PPP over Ethernet Session Limit Support, page 106](#)

Finding Feature Information

Your software release may not support all the features documented in this module. For the latest caveats and feature information, see [Bug Search Tool](#) and the release notes for your platform and software release. To find information about the features documented in this module, and to see a list of the releases in which each feature is supported, see the feature information table.

Use Cisco Feature Navigator to find information about platform support and Cisco software image support. To access Cisco Feature Navigator, go to www.cisco.com/go/cfn. An account on Cisco.com is not required.

Information About Configuring PPP over Ethernet Session Limit Support

Benefits of Configuring PPP over Ethernet Session Limit Support

- The PPPoE Session Limit Support feature prevents the router from using too much memory for virtual access by limiting the number of PPPoE sessions that can be created on a router or on all Ethernet interfaces and subinterfaces as well as ATM interfaces and subinterfaces.
- The SNMP Enhancements for ASR 1000 feature enhances Cisco ASR 1000 Aggregation Series Router to count the PPPoE sessions in PTA, FWDED, and TRANS state for a particular physical interface, and the total number of sessions that exist in a physical interface. Provision for using a system-wide threshold trap and per-physical threshold trap is provided through SNMP. These functionalities enable users to retrieve the total number of sessions and per-interface session-loss threshold value.

Trap Generation

In scenarios where you must deploy ASR 1000 Series Routers with one physical port mapped to one DSLAM and if the total number of sessions for the DSLAM falls below the threshold value on a physical interface, due to a loss of high number of sessions, a notification trap is generated. You can use these traps to investigate the issue and take immediate actions.

When the number of active sessions falls below the threshold value, only one trap is generated. Further traps are not sent even if the number of sessions continue to decrease. The next set of traps are sent only if the number of sessions rise above the configured threshold value and fall. This criterion is applicable to both global and per-interface traps.

When threshold values are configured in both global and per-interface configuration modes, then both the threshold values are monitored separately. Traps are sent when the session count falls below the threshold value either in global configuration mode or in per-interface configuration mode.

How to Configure PPP over Ethernet Session Limit Support

Specifying the Maximum Number of PPPoE Sessions on a Router

Perform this task to specify the maximum number of PPPoE sessions that can be created on a router.

SUMMARY STEPS

1. **enable**
2. **configure terminal**
3. **bba-group pppoe** *{name | global}*
4. **virtual-template** *template-number*
5. **sessions per-mac limit** *per-mac-limit*
6. **sessions per-vlan limit** *per-vlan-limit* [**inner** *vlan-id*]
7. **sessions per-vc limit** *per-vc-limit* [**threshold** *threshold-value*]
8. **sessions max limit** *number-of-sessions* [**threshold** *threshold-value*]
9. **exit**

DETAILED STEPS

	Command or Action	Purpose
Step 1	enable Example: Router> enable	Enables privileged EXEC mode. • Enter your password if prompted.
Step 2	configure terminal Example: Router# configure terminal	Enters global configuration mode.
Step 3	bba-group pppoe <i>{name global}</i> Example: Router(config)# bba-group pppoe global	Configures a broadband aggregation (BBA) group to be used to establish PPPoE sessions and enters BBA group configuration mode. • name --Name of the BBA group. You can have multiple BBA groups. • global -- Specifies the PPPoE profile that serves as the default profile for any PPPoE port (Gigabit Ethernet interface or VLAN) that has not been assigned a specific PPPoE profile.
Step 4	virtual-template <i>template-number</i> Example: Router(config-bba-group)# virtual-template 1	Specifies the virtual template that will be used to clone virtual access interfaces for all PPPoE ports that use this PPPoE profile.
Step 5	sessions per-mac limit <i>per-mac-limit</i> Example: Router(config-bba-group)# sessions per-mac limit 1000	(Optional) Configures the maximum number of PPPoE sessions allowed per MAC session limit in a PPPoE profile. The default MAC session limit is 100.

	Command or Action	Purpose
Step 6	<p>sessions per-vlan limit <i>per-vlan-limit</i> [inner <i>vlan-id</i>]</p> <p>Example:</p> <pre>Router(config-bba-group)# session per-vlan limit 4000 inner 3500</pre>	<p>(Optional) Sets the session limit for the inner VLAN on QinQ subinterface. The default session limit is 100.</p> <p>Note The per-VLAN limit is only applicable to Gigabit Ethernet subinterfaces (802.1q VLANs).</p>
Step 7	<p>sessions per-vc limit <i>per-vc-limit</i> [threshold <i>threshold-value</i>]</p> <p>Example:</p> <pre>Router(config-bba-group)# sessions per-vc limit 2000</pre>	<p>(Optional) Sets the maximum number of PPPoE sessions allowed per VC session limit in a PPPoE profile. The default session limit is 100.</p> <p>Note The per-VC limit is applicable only to ATM interfaces and subinterfaces.</p>
Step 8	<p>sessions max limit <i>number-of-sessions</i> [threshold <i>threshold-value</i>]</p> <p>Example:</p> <pre>Router(config-bba-group)# sessions max limit 32000</pre>	<p>Configures the PPPoE global profile with the maximum number of PPPoE sessions that will be permitted on a router, and sets the PPPoE session-count threshold at which a Simple Network Management Protocol (SNMP) trap will be generated.</p> <p>Note This command applies only to the global profile.</p>
Step 9	<p>exit</p> <p>Example:</p> <pre>Router(config-bba-group)# exit</pre>	<p>Returns to global configuration mode.</p>

Specifying the Maximum Number of PPPoE Sessions on a Gigabit Ethernet Interface

Perform this task to specify the maximum number of PPPoE sessions that can be created on a Gigabit Ethernet interface.

SUMMARY STEPS

1. **enable**
2. **configure terminal**
3. **interface** {GigabitEthernet | tenGigabitEthernet} *slot / subslot / port* [*. subinterface*]
4. **pppoe enable** [**group** *group-name*]
5. **pppoe max-sessions** *number*
6. **end**

DETAILED STEPS

	Command or Action	Purpose
Step 1	enable Example: Router> enable	Enables privileged EXEC mode. <ul style="list-style-type: none"> • Enter your password if prompted.
Step 2	configure terminal Example: Router# configure terminal	Enters global configuration mode.
Step 3	interface {GigabitEthernet tenGigabitEthernet} slot / subslot / port[. subinterface] Example: Router(config)# interface GigabitEthernet0/0/1	Specifies a Gigabit Ethernet interface and enters interface configuration mode.
Step 4	pppoe enable [group group-name] Example: Router(config-if)# pppoe enable group one	Enables PPPoE sessions on a Gigabit Ethernet interface or subinterface. <p>Note If a PPPoE profile is not assigned to the interface through the use of the group group-name option, the interface will use the global PPPoE profile.</p>
Step 5	pppoe max-sessions number Example: Router(config-if)# pppoe max-sessions 10	Specifies the maximum number of PPPoE sessions permitted on the interface or subinterface.
Step 6	end Example: Router(config-if)# end	(Optional) Exits interface configuration mode and returns to privileged EXEC mode.

Configuring System-Wide Threshold Parameters

Perform this task to configure the system-wide threshold parameters.

SUMMARY STEPS

1. **enable**
2. **configure terminal**
3. **bba-group ppp oe globa l**
4. **sessions threshold *number***
5. **exit**
6. **interface type *number***
7. **pppoe-sessions threshold *number***
8. **end**
9. **show pppoe summary**

DETAILED STEPS

	Command or Action	Purpose
Step 1	enable Example: Router> enable	Enables privileged EXEC mode.
Step 2	configure terminal Example: Router> configure terminal	Enters global configuration mode.
Step 3	bba-group ppp oe globa l Example: Router(config)# bba-group pppoe global	Defines a PPPoE profile and enters BBA group configuration mode.
Step 4	sessions threshold <i>number</i> Example: Router(config-bba-group)# sessions threshold 1000	Configures the global threshold value.
Step 5	exit Example: Router(config-bba-group)# exit	Exits BBA group configuration mode and returns to privileged EXEC mode.

	Command or Action	Purpose
Step 6	interface <i>type number</i> Example: Router(config-if)# interface GigabitEthernet 0/0	Enters interface configuration mode.
Step 7	pppoe-sessions threshold <i>number</i> Example: Router(config-if)# pppoe-sessions threshold 1000	Configures per-session threshold value.
Step 8	end Example: Router(config-if)# end	Exits interface configuration mode and returns to privileged EXEC mode
Step 9	show pppoe summary Example: Router# show pppoe summary	Displays the count of PPPoE sessions in PTA, FWDED, and TRANS state for a particular physical interface.

Configuration Examples for PPP over Ethernet Session Limit Support

Example Specifying the Maximum Number of PPPoE Sessions on a Router

The following example shows how to configure a limit of 1,000 PPPoE sessions for the router:

```
bba-group pppoe global
 virtual-template 1
  sessions per-mac limit 1000
  sessions per-vlan limit 4000 inner 3500
  sessions per-vc limit 2000
```

Example Specifying the Maximum Number of PPPoE Sessions on a Gigabit Ethernet Interface

The following example shows how to configure a limit of ten PPPoE sessions on the Gigabit Ethernet interface:

```
interface GigabitEthernet 1/0/0
```

```
pppoe enable
pppoe max-sessions 10
```

The following example shows how to configure a limit of ten PPPoE sessions on the Gigabit Ethernet subinterface by using the **encapsulation** command:

```
interface GigabitEthernet 0/0/0.1
 encapsulation dot1q 2
 pppoe enable
 pppoe max-sessions 10
```

Example Configuring the System-wide Threshold Parameters

The following example shows how to configure global and per-session threshold values:

```
Router# configure terminal
Router(config)# bba-group pppoe global
Router(config-bba-group)# sessions threshold 1000
Router(config-bba-group)# exit
Router# configure terminal
```

```
Router(config)# interface GigabitEthernet 0/0
```

```
Router(config-if)# pppoe-sessions threshold 90
Router(config-if)# end
```

The following example shows how to use the **show pppoe summary** command to display the count of the PPPoE sessions:

```
Router# show pppoe summary
PTA : Locally terminated sessions
FWDED: Forwarded sessions
TRANS: All other sessions (in transient state)
TOTAL PTA   FWDED TRANS
TOTAL 1     1     0     0
GigabitEthernet0/3/1 1     1     0     0
```

Additional References

Related Documents

Related Topic	Document Title
Cisco IOS commands	Cisco IOS Master Commands List, All Releases
Broadband and DSL commands	<i>Cisco IOS Broadband and DSL Command Reference</i>
Broadband access aggregation of PPPoE sessions	Providing Protocol Support for Broadband Access Aggregation of PPPoE Sessions

Standards

Standards	Title
No new or modified standards are supported by this feature, and support for existing standards has not been modified by this feature.	--

MIBs

MIBs	MIBs Link
No new or modified MIBs are supported by this feature, and support for existing MIBs has not been modified by this feature.	To locate and download MIBs for selected platforms, Cisco software releases, and feature sets, use Cisco MIB Locator found at the following URL: http://www.cisco.com/go/mibs

RFCs

RFCs	Title
No new or modified RFCs are supported by this feature, and support for existing RFCs has not been modified by this feature.	--

Technical Assistance

Description	Link
The Cisco Support and Documentation website provides online resources to download documentation, software, and tools. Use these resources to install and configure the software and to troubleshoot and resolve technical issues with Cisco products and technologies. Access to most tools on the Cisco Support and Documentation website requires a Cisco.com user ID and password.	http://www.cisco.com/cisco/web/support/index.html

Feature Information for Configuring PPP over Ethernet Session Limit Support

The following table provides release information about the feature or features described in this module. This table lists only the software release that introduced support for a given feature in a given software release train. Unless noted otherwise, subsequent releases of that software release train also support that feature.

Use Cisco Feature Navigator to find information about platform support and Cisco software image support. To access Cisco Feature Navigator, go to www.cisco.com/go/cfn. An account on Cisco.com is not required.

Table 11: Feature Information for Providing PPP over Ethernet Session Limit Support

Feature Name	Releases	Feature Information
PPP over Ethernet Session Limit Support	Cisco IOS XE Release 2.1 Cisco IOS XE Release 2.4	This feature was introduced on Cisco ASR 1000 Series Aggregation Services Routers. The PPPoE Session Limit Support feature enables you to limit the number of PPPoE sessions that can be created on a router or on a Gigabit Ethernet interface for configuration. This feature was integrated into Cisco IOS XE Release 2.4.
SNMP Enhancements for ASR 1000	Cisco IOS XE Release 3.2S	The SNMP Enhancements for ASR 1000 feature enhances Cisco ASR 1000 Aggregation Series Routers to provide the count of the PPPOE sessions in PTA, Forwarded, and TRANS state for a particular physical interface, and the total count of sessions that exist in a physical interface. This feature was introduced in Cisco IOS XE 3.2S. The following commands were introduced or modified: pppoe-sessions threshold, sessions threshold.



PPPoE Session Limit Local Override

The PPPoE Session Limit Local Override feature enables the session limit configured locally on the broadband remote access server (BRAS) or L2TP access concentrator (LAC) to override the per-NAS-port session limit downloaded from the RADIUS server when Subscriber Service Switch (SSS) preauthorization is enabled.

- [Finding Feature Information, page 107](#)
- [Information About PPPoE Session Limit Local Override, page 107](#)
- [How to Configure PPPoE Session Limit Local Override, page 108](#)
- [Configuration Examples for PPPoE Session Limit Local Override, page 110](#)
- [Additional References, page 110](#)
- [Feature Information for PPPoE Session Limit Local Override, page 111](#)

Finding Feature Information

Your software release may not support all the features documented in this module. For the latest caveats and feature information, see [Bug Search Tool](#) and the release notes for your platform and software release. To find information about the features documented in this module, and to see a list of the releases in which each feature is supported, see the feature information table.

Use Cisco Feature Navigator to find information about platform support and Cisco software image support. To access Cisco Feature Navigator, go to www.cisco.com/go/cfn. An account on Cisco.com is not required.

Information About PPPoE Session Limit Local Override

How PPPoE Session Limit Local Override Works

PPP over Ethernet (PPPoE) session limits are downloaded from the RADIUS server when you enable SSS preauthorization on the LAC using the **subscriber access pppoe pre-authorize nas-port-id** command. By enabling preauthorization, you limit the number of PPPoE sessions on a specific VLAN; that is, the PPPoE per-NAS-port session limit downloaded from the RADIUS server takes precedence over locally configured

(port-based) session limits, such as per-VLAN session limits. The following is a sample user profile to configure a session limit through RADIUS:

```
Username=nas_port:10.10.10.10:4/0/0/1.100
Password = "password1"
cisco-avpair= "pppoe:session-limit=session limit per NAS-port"
```

The PPPoE Session Limit Local Override feature enables the local session limit configured at the BRAS to override the per-NAS-port session limit configured at the RADIUS server when SSS preauthorization is configured.

Note

The PPPoE Session Limit Local Override feature is useful only when you have configured SSS preauthorization on the BRAS or LAC.

To enable the PPPoE Session Limit Local Override feature, configure the **sessions pre-auth limit ignore** command under the broadband access (BBA) group associated with the interface. When the PPPoE Session Limit Local Override feature is enabled, the locally configured session limit is applied before PPP is started; that is before the BRAS sends out a PPPoE Active Discovery Offer (PADO) packet to the client, advertising a list of available services.

When preauthorization is configured without the PPPoE Session Limit Local Override feature enabled, the client receives an authentication failure response from the BRAS when there is no session limit downloaded from the RADIUS server and the locally configured session limit is exceeded. The BRAS waits to apply locally configured limits until PPP negotiation is completed. When a call is finally rejected, the client receives the authentication failure response, resulting in session failure, with no ability to distinguish whether the session failure results from a Challenge Handshake Authentication Protocol (CHAP) authentication failure or a PPPoE session limit having been exceeded. The PPPoE Session Limit Local Override feature allows for differentiation between the handling of per-NAS-port failures and session limiting failures.

If you enable the PPPoE Session Limit Local Override feature, but there are no locally configured per-port session limits, then per-NAS-port session limits downloaded from the RADIUS server are applied.

How to Configure PPPoE Session Limit Local Override

Enabling PPPoE Session Limit Local Override

Enable the PPPoE Session Limit Local Override feature to allow the local session limit configured on the BRAS to override the per-NAS-port session limit downloaded from the RADIUS server.

Note

If there are no locally configured per-port session limits, then per-NAS port session limits downloaded from the RADIUS server are applied.

>

SUMMARY STEPS

1. **enable**
2. **configure terminal**
3. **bba-group pppoe** *{group-name | global}*
4. **sessions per-vlan limit** *per-vlan-limit*
5. **sessions pre-auth limit ignore**
6. **end**

DETAILED STEPS

	Command or Action	Purpose
Step 1	enable Example: Router> enable	Enables privileged EXEC mode. • Enter your password if prompted.
Step 2	configure terminal Example: Router# configure terminal	Enters global configuration mode.
Step 3	bba-group pppoe <i>{group-name global}</i> Example: Router(config)# bba-group pppoe test	Creates a PPPoE profile and enters BBA group configuration mode. • <i>group-name</i> --Name of the PPPoE profile.
Step 4	sessions per-vlan limit <i>per-vlan-limit</i> Example: Router(config-bba-group)# sessions per-vlan limit 3	Limits the number of PPPoE sessions per VLAN in a PPPoE profile. • <i>per-vlan-limit</i> --Maximum number of PPPoE sessions that can be established over an Ethernet VLAN. The default is 100.
Step 5	sessions pre-auth limit ignore Example: Router(config-bba-group)# sessions pre-auth limit ignore	Enables the PPPoE Session Limit Local Override feature. The locally configured limit overrides the per-NAS-port session limit configured at the RADIUS server.
Step 6	end Example: Router(config-bba-group)# end	Exits BBA group configuration mode and returns to privileged EXEC mode.

Configuration Examples for PPPoE Session Limit Local Override

Enabling PPPoE Session Limit Local Override Example

The following example creates a PPPoE group named test, configures a limit of three sessions per VLAN, and enables the PPPoE Session Limit Local Override feature in bba-group configuration mode. The running configuration shows that the **sessions pre-auth limit ignore** command was used to enable this feature.

```
Router(config)# bba-group pppoe test
Router(config-bba-group)# sessions per-vlan limit 3
Router(config-bba-group)# sessions pre-auth limit ignore

.
.
!
bba-group pppoe test
virtual-template 2
sessions per-vlan limit 3
sessions pre-auth limit ignore
!
```

Additional References

The following sections provide references related to the PPPoE Session Limit Local Override feature.

Related Documents

Related Topic	Document Title
Additional information about commands used in this document	<ul style="list-style-type: none"> • Cisco IOS Broadband Access Aggregation and DSL Command Reference • Cisco IOS Master Command List, All Releases

Standards

Standard	Title
No new or modified standards are supported by this feature, and support for existing standards has not been modified by this feature.	--

MIBs

MIB	MIBs Link
No new or modified MIBs are supported by this feature, and support for existing MIBs has not been modified by this feature.	To locate and download MIBs for selected platforms, Cisco IOS XE releases, and feature sets, use Cisco MIB Locator found at the following URL: http://www.cisco.com/go/mibs

RFCs

RFCs	Title
No new or modified RFCs are supported by this feature, and support for existing RFCs has not been modified by this feature.	--

Technical Assistance

Description	Link
<p>The Cisco Support website provides extensive online resources, including documentation and tools for troubleshooting and resolving technical issues with Cisco products and technologies.</p> <p>To receive security and technical information about your products, you can subscribe to various services, such as the Product Alert Tool (accessed from Field Notices), the Cisco Technical Services Newsletter, and Really Simple Syndication (RSS) Feeds.</p> <p>Access to most tools on the Cisco Support website requires a Cisco.com user ID and password.</p>	http://www.cisco.com/techsupport

Feature Information for PPPoE Session Limit Local Override

The following table provides release information about the feature or features described in this module. This table lists only the software release that introduced support for a given feature in a given software release train. Unless noted otherwise, subsequent releases of that software release train also support that feature.

Use Cisco Feature Navigator to find information about platform support and Cisco software image support. To access Cisco Feature Navigator, go to www.cisco.com/go/cfn. An account on Cisco.com is not required.

Table 12: Feature Information for PPPoE Session Limit Local Override

Feature Name	Releases	Feature Information
PPPoE--Session Limit Local Override	Cisco IOS XE Release 2.1	<p>This feature was introduced on Cisco ASR 1000 Series Routers.</p> <p>This feature enables the session limit configured locally on the broadband remote access server (BRAS) or L2TP access concentrator (LAC) to override the per-NAS-port session limit downloaded from the RADIUS server when Subscriber Service Switch (SSS) preauthorization is enabled.</p> <p>The following commands were introduced or modified: sessions pre-auth limit ignore.</p>



PPPoE QinQ Support

The PPPoE QinQ Support feature installed at a subinterface level preserves VLAN IDs and segregates the traffic in different customer VLANs. Encapsulating IEEE 802.1Q VLAN tags within 802.1Q enables service providers to use a single VLAN to support customers who have multiple VLANs.

- [Finding Feature Information, page 113](#)
- [Prerequisites for PPPoE QinQ Support, page 113](#)
- [Information About PPPoE QinQ Support, page 114](#)
- [How to Configure PPPoE QinQ Support, page 117](#)
- [Configuration Examples for PPPoE QinQ Support, page 121](#)
- [Additional References, page 123](#)
- [Feature Information for PPPoE QinQ Support, page 125](#)

Finding Feature Information

Your software release may not support all the features documented in this module. For the latest caveats and feature information, see [Bug Search Tool](#) and the release notes for your platform and software release. To find information about the features documented in this module, and to see a list of the releases in which each feature is supported, see the feature information table.

Use Cisco Feature Navigator to find information about platform support and Cisco software image support. To access Cisco Feature Navigator, go to www.cisco.com/go/cfn. An account on Cisco.com is not required.

Prerequisites for PPPoE QinQ Support

- You have checked Cisco Feature Navigator at <http://www.cisco.com/go/cfn> to verify that your Cisco device and Cisco IOS XE release support this feature.
- You must be connected to an Ethernet device that supports double VLAN tag imposition/disposition or switching.

Information About PPPoE QinQ Support

PPPoE QinQ Support on Subinterfaces

The PPPoE QinQ Support feature adds another layer of IEEE 802.1Q tag (called "metro tag" or "PE-VLAN") to the 802.1Q tagged packets that enter the network. The purpose is to expand the VLAN space by tagging the tagged packets, thus producing a "double-tagged" frame. The expanded VLAN space allows service providers to offer assorted services on different VLANs. For example, certain customers can be provided Internet access on specific VLANs while other customers receive different services on other VLANs.

Generally the service provider's customers require a range of VLANs to handle multiple applications. Service providers can allow their customers to use this feature to safely assign their own VLAN IDs on subinterfaces because these subinterface VLAN IDs are encapsulated within a service provider-designated VLAN ID for that customer. Therefore there is no overlap of VLAN IDs among customers, nor does traffic from different customers become mixed. The double-tagged frame is "terminated" or assigned on a subinterface through use of an expanded **encapsulation dot1q** command that specifies the two VLAN ID tags (outer VLAN ID and inner VLAN ID) terminated on the subinterface. See .

The PPPoE QinQ Support feature is generally supported on whichever Cisco IOS XE features or protocols are supported on the subinterface. For example, if you can run PPPoE on the subinterface, you can configure a double-tagged frame for PPPoE. IPoQinQ supports IP packets that are double-tagged for QinQ VLAN tag termination by forwarding IP traffic with the double-tagged (also known as stacked) 802.1Q headers.

A primary consideration is whether you assign ambiguous or unambiguous subinterfaces for the inner VLAN ID. See the [Unambiguous and Ambiguous Subinterfaces](#), on page 116.

The primary benefit for the service provider is a reduced number of VLANs supported for the same number of customers. Other benefits of this feature are as follows:

- PPPoE scalability. Expanding the available VLAN space from 4096 to about 16.8 million (4096 times 4096) allows the number of PPPoE sessions that can be terminated on a given interface to be multiplied.
- When deploying Gigabyte Ethernet DSL access multiplexer (DSLAM) in a wholesale model, you can assign the inner VLAN ID to represent the end-customer virtual circuit (VC) and assign the outer VLAN ID to represent the service provider ID.

The QinQ VLAN tag termination feature is simpler than the IEEE 802.1Q tunneling feature deployed for switches. Whereas switches require IEEE 802.1Q tunnels on interfaces to carry double-tagged traffic, routers

need only encapsulate QinQ VLAN tags within another level of 802.1Q tags in order for the packets to arrive at the correct destination.

Figure 10: Untagged, 802.1Q-Tagged, and Double-Tagged Ethernet Frames

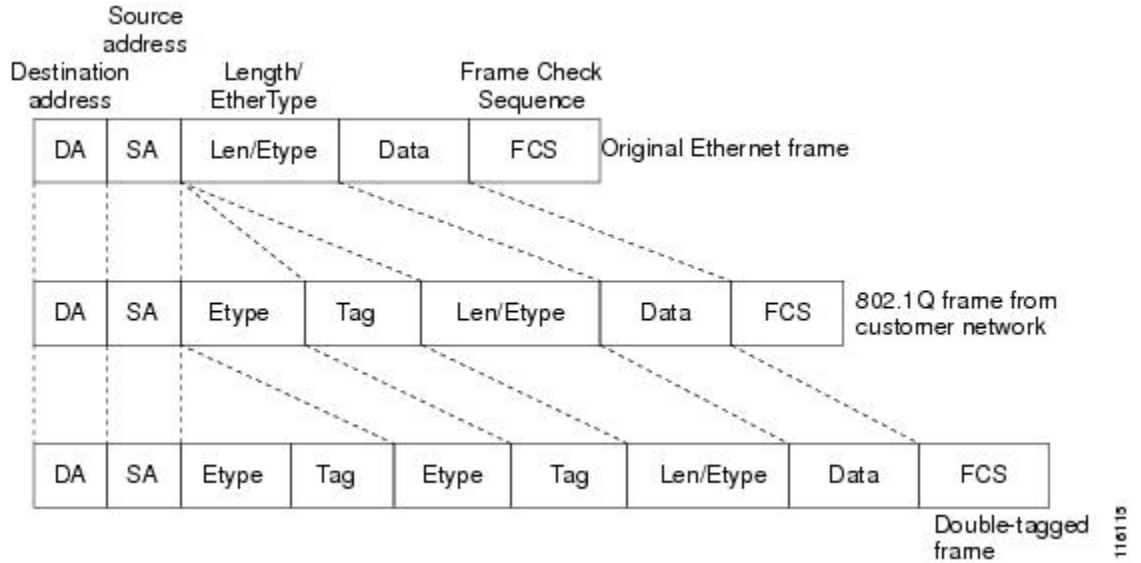

Broadband Ethernet-Based DSLAM Model of QinQ VLANs

For the emerging broadband Ethernet-based DSLAM market, the Cisco ASR 1000 Series Routers support QinQ encapsulation. With the Ethernet-based DSLAM model shown in the figure below, customers typically get their own VLAN; all these VLANs are aggregated on a DSLAM.

Figure 11: Broadband Ethernet-Based DSLAM Model of QinQ VLANs

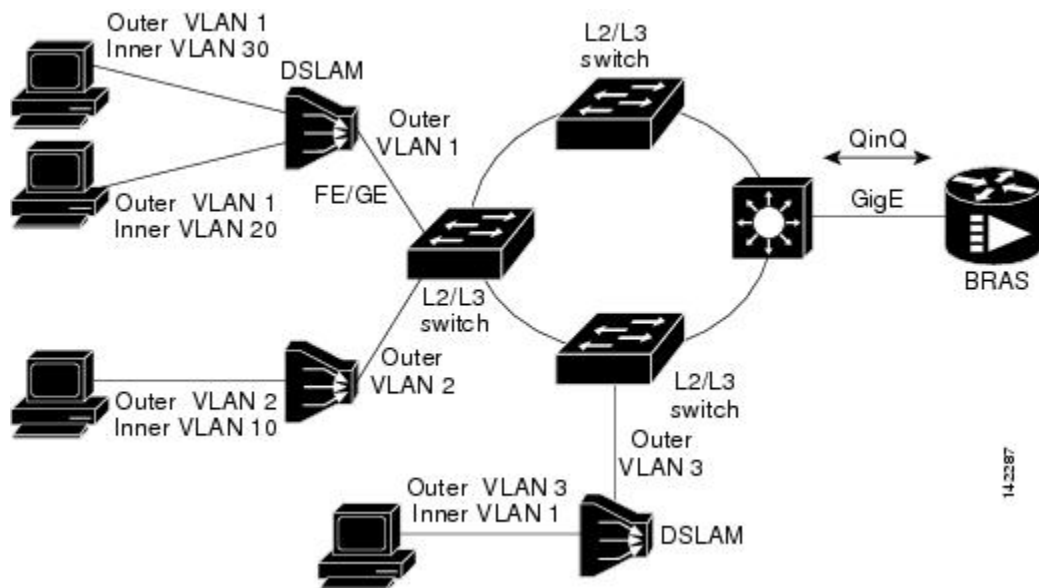

VLAN aggregation on a DSLAM will result in many aggregate VLANs that at some point need to be terminated on the broadband remote access servers (BRASs). Although the model could connect the DSLAMs directly to the BRAS, a more common model uses the existing Ethernet-switched network where each DSLAM VLAN ID is tagged with a second tag (QinQ) as it connects into the Ethernet-switched network.

Both PPPoE sessions and IP can be enabled on a subinterface. The PPPoEoQinQ model is a PPP-terminated session.

PPPoEQinQ and IPoQinQ encapsulation processing is an extension to 802.1Q encapsulation processing. A QinQ frame looks like a VLAN 802.1Q frame; the only difference is that it has two 802.1Q tags instead of one.

QinQ encapsulation supports configurable outer tag Ethertype. The configurable Ethertype field values are 0x8100 (default), 0x9100, 0x9200, and 0x8848. See the figure below.

Figure 12: Supported Configurable Ethertype Field Values



Unambiguous and Ambiguous Subinterfaces



Note

Only PPPoE is supported on ambiguous subinterfaces. Standard IP routing is not supported on ambiguous subinterfaces.

The **encapsulation dot1q** command is used to configure QinQ termination on a subinterface. The command accepts an outer VLAN ID and one or more inner VLAN IDs. The outer VLAN ID always has a specific value, and the inner VLAN ID can either be a specific value or a range of values.

A subinterface that is configured with a single inner VLAN ID is called an unambiguous QinQ subinterface. In the following example, QinQ traffic with an outer VLAN ID of 101 and an inner VLAN ID of 1001 is mapped to the Gigabit Ethernet 1/1/0.100 subinterface:

```
Router(config)# interface gigabitethernet1/1/0.100
Router(config-subif)# encapsulation dot1q 101 second-dot1q 1001
```

A subinterface that is configured with multiple inner VLAN IDs is called an ambiguous QinQ subinterface. By allowing multiple inner VLAN IDs to be grouped, ambiguous QinQ subinterfaces allow for a smaller configuration, improved memory usage, and better scalability.

In the following example, QinQ traffic with an outer VLAN ID of 101 and inner VLAN IDs anywhere in the 2001-2100 and 3001-3100 range is mapped to the Gigabit Ethernet 1/1/0.101 subinterface:

```
Router(config)# interface gigabitethernet1/1/0.101
Router(config-subif)# encapsulation dot1q 101 second-dot1q 2001-2100,3001-3100
```

Ambiguous subinterfaces can also use the **any** keyword to specify the inner VLAN ID.

See the [Configuration Examples for PPPoE QinQ Support](#), on page 121 for an example of how VLAN IDs are assigned to subinterfaces, and for a detailed example of how the **any** keyword is used on ambiguous subinterfaces.



Note The **any** keyword in the **second-dot1q** keyword is not supported on a subinterface configured for IPoQinQ because IP routing is not supported on ambiguous subinterfaces. Therefore, multiple values and ranges for the inner VLAN ID are not supported on IPoQinQ.

How to Configure PPPoE QinQ Support

Configuring the Interfaces for PPPoE QinQ Support

Perform this task to configure the main interface used for the QinQ double tagging and to configure the subinterfaces. An optional step in this task shows you how to configure the Ethertype field to be 0x9100 for the outer VLAN tag, if that is required. After the subinterface is defined, the 802.1Q encapsulation is configured to use the double tagging.

Before You Begin

- PPPoE or IP is already configured.

SUMMARY STEPS

1. **enable**
2. **configure terminal**
3. **interface** *type slot/subslot/port*
4. **dot1q tunneling ethertype** *ethertype*
5. **exit**
6. **interface** *type slot/subslot/port[.subinterface]*
7. **encapsulation dot1q** *vlan-id second-dot1q {any | vlan-id| vlan-id - vlan-id[, vlan-id - vlan-id]}*
8. **pppoe enable** [**group** *group-name*]
9. **ip address** *ip-address mask* [**secondary**]
10. **exit**
11. Repeat Step 6 to configure another subinterface.
12. Repeat Step 7, Step 8, and Step 9, as required, to specify the VLAN tags to be terminated on the subinterface.
13. **end**

DETAILED STEPS

	Command or Action	Purpose
Step 1	<p>enable</p> <p>Example:</p> <pre>Router> enable</pre>	<p>Enables privileged EXEC mode.</p> <ul style="list-style-type: none"> • Enter your password if prompted.

	Command or Action	Purpose
Step 2	configure terminal Example: Router# configure terminal	Enters global configuration mode.
Step 3	interface type slot/subslot/port Example: Router(config)# interface gigabitethernet 1/0/0	Configures an interface and enters interface configuration mode.
Step 4	dot1q tunneling ethertype ethertype Example: Router(config-if)# dot1q tunneling ethertype 0x9100	(Optional) Defines the Ethertype field type used by peer devices when implementing QinQ VLAN tagging. <ul style="list-style-type: none"> Use this command if the Ethertype of peer devices is 0x9100 or 0x9200.
Step 5	exit Example: Router(config-if)# exit	Exits the interface configuration mode.
Step 6	interface type slot/subslot/port[.subinterface] Example: Router(config-if)# interface gigabitethernet 1/0/0.1	Configures a subinterface and enters subinterface configuration mode.
Step 7	encapsulation dot1q vlan-id second-dot1q {any vlan-id vlan-id - vlan-id[, vlan-id - vlan-id]} Example: Router(config-subif)# encapsulation dot1q 100 second-dot1q 200	(Required) Enables the 802.1Q encapsulation of traffic on a specified subinterface in a VLAN. <ul style="list-style-type: none"> Use the second-dot1q keyword and the <i>vlan-id</i> argument to specify the VLAN tags to be terminated on the subinterface. In this example, an unambiguous QinQ subinterface is configured because only one inner VLAN ID is specified. QinQ frames with an outer VLAN ID of 100 and an inner VLAN ID of 200 will be terminated.
Step 8	pppoe enable [group group-name] Example: Router(config-subif)# pppoe enable group vpn1	(Optional) Enables PPPoE sessions on a subinterface. <ul style="list-style-type: none"> The example specifies that the PPPoE profile, <i>vpn1</i>, will be used by PPPoE sessions on the subinterface. <p>Note This step is required only for PPPoEoQinQ.</p>

	Command or Action	Purpose
Step 9	<p>ip address <i>ip-address mask</i> [secondary]</p> <p>Example:</p> <pre>Router(config-subif)# ip address 192.168.1.2 255.255.255.0</pre>	<p>(Optional) Sets a primary or secondary IP address for a subinterface.</p> <ul style="list-style-type: none"> The example enables IP on the subinterface specified by the IP address, 192.168.1.2, and mask, 255.255.255.0. <p>Note This step is required only for IPoQinQ.</p>
Step 10	<p>exit</p> <p>Example:</p> <pre>Router(config-subif)# exit</pre>	<p>Exits subinterface configuration mode.</p>
Step 11	<p>Repeat Step 6 to configure another subinterface.</p> <p>Example:</p> <pre>Router(config-if)# interface gigabitethernet 1/0/0.2</pre>	<p>(Optional) Configures a subinterface and enters subinterface configuration mode.</p>
Step 12	<p>Repeat Step 7, Step 8, and Step 9, as required, to specify the VLAN tags to be terminated on the subinterface.</p> <p>Example:</p> <pre>Router(config-subif)# encapsulation dot1q 100 second-dot1q 100-199,201-600</pre> <p>Example:</p> <pre>Router(config-subif)# pppoe enable group vpn1</pre> <p>Example:</p> <pre>Router(config-subif)# ip address 192.168.1.2 255.255.255.0</pre>	<p>Specifies the VLAN tags to be terminated on the subinterface, to enable PPPoE sessions or IP on the subinterface.</p> <ul style="list-style-type: none"> Use the second-dot1q keyword and the <i>vlan-id</i> argument to specify the VLAN tags to be terminated on the subinterface. In the example, an ambiguous QinQ subinterface is configured because a range of inner VLAN IDs is specified. QinQ frames with an outer VLAN ID of 100 and an inner VLAN ID in the range of 100 to 199 or 201 to 600 will be terminated. Step 7 enables the 802.1Q encapsulation of traffic on a specified subinterface in a VLAN. Step 8 enables PPPoE sessions on the subinterface. The example specifies that the PPPoE profile, vpn1, will be used by PPPoE sessions on the subinterface. Step 9 enables IP on a subinterface specified by the IP address and mask. The example enables IP on the subinterface specified by the IP address, 192.168.1.2, and mask, 255.255.255.0. <p>Note Both PPPoE sessions and IP can be enabled on a subinterface.</p>
Step 13	<p>end</p> <p>Example:</p> <pre>Router(config-subif)# end</pre>	<p>Exits subinterface configuration mode and returns to privileged EXEC mode.</p>

Verifying the PPPoE QinQ Support

Perform this optional task to verify the configuration of the PPPoE QinQ Support feature.

SUMMARY STEPS

1. **enable**
2. **show running-config**
3. **show vlans dot1q** [**internal** | *interface-type interface-number.subinterface-number* [**detail**] | *outer-id* [*interface-type interface-number* | **second-dot1q** [*inner-id*] **any**]] [**detail**]

DETAILED STEPS

Step 1

enable

Enables privileged EXEC mode. Enter your password if prompted.

Example:

```
Router> enable
```

Step 2

show running-config

Use this command to show the currently running configuration on the device. You can use delimiting characters to display only the relevant parts of the configuration.

The following output shows the currently running PPPoEoQinQ and IPoQinQ configurations:

Example:

```
Router# show running-config
interface GigabitEthernet0/0/0.201
 encapsulation dot1q 201
 ip address 10.7.7.5 255.255.255.252
!
interface GigabitEthernet0/0/0.401
 encapsulation dot1q 401
 ip address 10.7.7.13 255.255.255.252
!
interface GigabitEthernet0/0/0.201999
 encapsulation dot1q 201 second-dot1q any
 pppoe enable
!
interface GigabitEthernet0/0/0.2012001
 encapsulation dot1q 201 second-dot1q 2001
 ip address 10.8.8.9 255.255.255.252
!
interface GigabitEthernet0/0/0.2012002
 encapsulation dot1q 201 second-dot1q 2002
 ip address 10.8.8.13 255.255.255.252
 pppoe enable
!
interface GigabitEthernet0/0/0.4019999
 encapsulation dot1q 401 second-dot1q 100-900,1001-2000
 pppoe enable
!
interface GigabitEthernet1/0/0.101
 encapsulation dot1q 101
 ip address 10.7.7.1 255.255.255.252
```



```

!
interface GigabitEthernet1/0/0.301
 encapsulation dot1Q 301
 ip address 10.7.7.9 255.255.255.252
!
interface GigabitEthernet1/0/0.301999
 encapsulation dot1Q 301 second-dot1q any
 pppoe enable
!
interface GigabitEthernet1/0/0.1011001
 encapsulation dot1Q 101 second-dot1q 1001
 ip address 10.8.8.1 255.255.255.252
!
interface GigabitEthernet1/0/0.1011002
 encapsulation dot1Q 101 second-dot1q 1002
 ip address 10.8.8.5 255.255.255.252
!
interface GigabitEthernet1/0/0.1019999
 encapsulation dot1Q 101 second-dot1q 1-1000,1003-2000
 pppoe enable

```

Step 3 `show vlans dot1q [internal | interface-type interface-number.subinterface-number[detail] | outer-id[interface-type interface-number | second-dot1q [inner-id| any]] [detail]]`

Use this command to show the statistics for all the 802.1Q VLAN IDs. In the following example, only the outer VLAN ID is displayed:

Note The **any** keyword is not supported on a subinterface configured for IPoQinQ because IP routing is not supported on ambiguous subinterfaces.

Example:

```

Router# show vlans dot1q
Total statistics for 802.1Q VLAN 1:
 441 packets, 85825 bytes input
 1028 packets, 69082 bytes output
Total statistics for 802.1Q VLAN 101:
 5173 packets, 510384 bytes input
 3042 packets, 369567 bytes output
Total statistics for 802.1Q VLAN 201:
 1012 packets, 119254 bytes input
 1018 packets, 120393 bytes output
Total statistics for 802.1Q VLAN 301:
 3163 packets, 265272 bytes input
 1011 packets, 120750 bytes output
Total statistics for 802.1Q VLAN 401:
 1012 packets, 119254 bytes input
 1010 packets, 119108 bytes output

```

Configuration Examples for PPPoE QinQ Support

Configuring the any Keyword on Subinterfaces for PPPoE QinQ Support Example

Some ambiguous subinterfaces can use the **any** keyword for the inner VLAN ID specification. The **any** keyword represents any inner VLAN ID that is not explicitly configured on any other interface. In the following example, seven subinterfaces are configured with various outer and inner VLAN IDs.



Note The **any** keyword can be configured on only one subinterface of a specified physical interface and outer VLAN ID.



Note The **any** keyword in the **second-dot1q** keyword is not supported on a subinterface configured for IPoQinQ because IP routing is not supported on ambiguous subinterfaces. Therefore, multiple values and ranges for the inner VLAN ID are not supported on IPoQinQ.

```
interface GigabitEthernet1/0/0.1
 encapsulation dot1q 100 second-dot1q 100
interface GigabitEthernet1/0/0.2
 encapsulation dot1q 100 second-dot1q 200
interface GigabitEthernet1/0/0.3
 encapsulation dot1q 100 second-dot1q 300-400,500-600
interface GigabitEthernet1/0/0.4
 encapsulation dot1q 100 second-dot1q any
interface GigabitEthernet1/0/0.5
 encapsulation dot1q 200 second-dot1q 50
interface GigabitEthernet1/0/0.6
 encapsulation dot1q 200 second-dot1q 1000-2000,3000-4000
interface GigabitEthernet1/0/0.7
 encapsulation dot1q 200 second-dot1q any
```

The table below shows which subinterfaces are mapped to different values of the outer and inner VLAN IDs on QinQ frames that come in on Gigabit Ethernet (GE) interface 1/0/0.

Table 13: Subinterfaces Mapped to Outer and Inner VLAN IDs for GE Interface 1/0/0

Outer VLAN ID	Inner VLAN ID	Subinterface Mapped to
100	1 through 99	GigabitEthernet1/0/0.4
100	100	GigabitEthernet1/0/0.1
100	101 through 199	GigabitEthernet1/0/0.4
100	200	GigabitEthernet1/0/0.2
100	201 through 299	GigabitEthernet1/0/0.4
100	300 through 400	GigabitEthernet1/0/0.3
100	401 through 499	GigabitEthernet1/0/0.4
100	500 through 600	GigabitEthernet1/0/0.3
100	601 through 4094	GigabitEthernet1/0/0.4
200	1 through 49	GigabitEthernet1/0/0.7
200	50	GigabitEthernet1/0/0.5
200	51 through 999	GigabitEthernet1/0/0.7

Outer VLAN ID	Inner VLAN ID	Subinterface Mapped to
200	1000 through 2000	GigabitEthernet1/0/0.6
200	2001 through 2999	GigabitEthernet1/0/0.7
200	3000 through 4000	GigabitEthernet1/0/0.6
200	4001 through 4094	GigabitEthernet1/0/0.7

A new subinterface is now configured:

```
interface GigabitEthernet 1/0/0.8
 encapsulation dot1q 200 second-dot1q 200-600,900-999
```

The table below shows the changes made to the table for the outer VLAN ID of 200. Notice that subinterface 1/0/0.7 configured with the **any** keyword now has new inner VLAN ID mappings.

Table 14: Subinterfaces Mapped to Outer and Inner VLAN IDs for GE Interface 1/0/0--Changes Resulting from Configuring GE Subinterface 1/0/0.8

Outer VLAN ID	Inner VLAN ID	Subinterface mapped to
200	1 through 49	GigabitEthernet1/0/0.7
200	50	GigabitEthernet1/0/0.5
200	51 through 199	GigabitEthernet1/0/0.7
200	200 through 600	GigabitEthernet1/0/0.8
200	601 through 899	GigabitEthernet1/0/0.7
200	900 through 999	GigabitEthernet1/0/0.8
200	1000 through 2000	GigabitEthernet1/0/0.6
200	2001 through 2999	GigabitEthernet1/0/0.7
200	3000 through 4000	GigabitEthernet1/0/0.6
200	4001 through 4094	GigabitEthernet1/0/0.7

Additional References

The following sections provide references related to the PPPoE QinQ Support feature.

Related Documents

Related Topic	Document Title
Additional information about commands used in this document	<ul style="list-style-type: none"> • <i>Cisco IOS Broadband Access Aggregation and DSL Command Reference</i> • Cisco IOS Master Command List, All Releases

Standards

Standards	Title
IEEE 802.1Q	IEEE Standard for Local and Metropolitan Area Networks

MIBs

MIBs	MIBs Link
No new or modified MIBs are supported by this feature, and support for existing MIBs has not been modified by this feature.	To locate and download MIBs for selected platforms, Cisco IOS XE releases, and feature sets, use Cisco MIB Locator found at the following URL: http://www.cisco.com/go/mibs

RFCs

RFCs	Title
No new or modified RFCs are supported by this feature, and support for existing RFCs has not been modified by this feature.	--

Technical Assistance

Description	Link
<p>The Cisco Support website provides extensive online resources, including documentation and tools for troubleshooting and resolving technical issues with Cisco products and technologies.</p> <p>To receive security and technical information about your products, you can subscribe to various services, such as the Product Alert Tool (accessed from Field Notices), the Cisco Technical Services Newsletter, and Really Simple Syndication (RSS) Feeds.</p> <p>Access to most tools on the Cisco Support website requires a Cisco.com user ID and password.</p>	<p>http://www.cisco.com/techsupport</p>

Feature Information for PPPoE QinQ Support

The following table provides release information about the feature or features described in this module. This table lists only the software release that introduced support for a given feature in a given software release train. Unless noted otherwise, subsequent releases of that software release train also support that feature.

Use Cisco Feature Navigator to find information about platform support and Cisco software image support. To access Cisco Feature Navigator, go to www.cisco.com/go/cfn. An account on Cisco.com is not required.

Table 15: Feature Information for PPPoE QinQ Support

Feature Name	Releases	Feature Information
<p>IEEE 802.1Q-in-Q VLAN Tag Termination</p>	<p>Cisco IOS XE Release 2.1</p>	<p>This feature was introduced on Cisco ASR 1000 Series Routers.</p> <p>Encapsulating IEEE 802.1Q VLAN tags within 802.1Q enables service providers to use a single VLAN to support customers who have multiple VLANs.</p>

Feature Name	Releases	Feature Information
PPPoE QinQ Support	Cisco IOS XE Release 2.2	<p>This feature was introduced on Cisco ASR 1000 Series Routers.</p> <p>This feature on the subinterface level preserves VLAN IDs and keeps traffic in different customer VLANs segregated.</p> <p>The following commands were introduced or modified: dot1q tunneling ethertype, encapsulation dot1q, show vlans dot1q.</p>



PPP-Max-Payload and IWF PPPoE Tag Support

The PPP-Max-Payload and IWF PPPoE Tag Support feature enables the PPP over Ethernet (PPPoE) component to process the PPP-Max-Payload and Interworking Functionality (IWF) PPPoE tags in the PPPoE discovery frame:

- The **tag ppp-max-payload** command allows PPPoE peers to negotiate PPP maximum receive units (MRUs) greater than 1492 octets if the underlying network supports a maximum transmission unit (MTU) size greater than 1500 octets.
- The IWF PPPoE tag allows the Broadband Remote Access Server (BRAS) to distinguish the IWF PPPoE from the regular PPPoE sessions to overcome the per-MAC session limit put on the BRAS as a protection from denial of service (DOS) attacks sourced from the same MAC address.
- [Finding Feature Information, page 127](#)
- [Information About PPP-Max-Payload and IWF PPPoE Tag Support, page 128](#)
- [How to Configure PPP-Max-Payload and IWF PPPoE Tag Support, page 128](#)
- [Configuration Examples for PPP-Max Payload and IWF PPPoE Tag Support, page 132](#)
- [Additional References, page 133](#)
- [Feature Information for PPP-Max-Payload and IWF PPPoE Tag Support, page 134](#)

Finding Feature Information

Your software release may not support all the features documented in this module. For the latest caveats and feature information, see [Bug Search Tool](#) and the release notes for your platform and software release. To find information about the features documented in this module, and to see a list of the releases in which each feature is supported, see the feature information table.

Use Cisco Feature Navigator to find information about platform support and Cisco software image support. To access Cisco Feature Navigator, go to www.cisco.com/go/cfn. An account on Cisco.com is not required.

Information About PPP-Max-Payload and IWF PPPoE Tag Support

Accommodating an MTU MRU Greater than 1492 in PPPoE

Per the RFC, "Accommodating an MTU/MRU Greater than 1492 in PPPoE," PPPoE peers can negotiate only MRUs with a maximum of 1492 octets so that the PPPoE header and PPP protocol ID can be inserted in the PPPoE session data packet. The maximum for an Ethernet payload is 1500 octets.

RFC 2516 defines a new tag to allow PPPoE peers to negotiate PPP MRU greater than 1492 if the underlying networks can support an Ethernet payload of greater than 1500 bytes. To enable processing of this new tag, a command has been defined in the Cisco IOS command-line interface as **tag ppp-max-payload**. The PPP-Max-Payload and IWF PPPoE Tag Support feature enhances the PPPoE component so the **tag ppp-max-payload** command can process the new tag to influence the Link Control Protocol (LCP) MRU negotiations for the PPP session based on the MRU value specified in the tag from the PPPoE client.

Interworking Functionality

The DSL Forum defined IWF to define the process for conversion of PPP over ATM (PPPoA) sessions to PPPoE sessions at the digital subscriber line access multiplexer (DSLAM) to the BRAS. This functionality was defined to help the migration of DSLAM networks from ATM to Ethernet media. So, essentially, the PPPoA session comes in to the DSLAM over ATM and is converted to a PPPoE session at the DSLAM, which is then connected to the BRAS as a PPPoE session. Each PPPoA session is mapped to a corresponding PPPoE session.

Typically, the BRAS is configured to limit PPPoE sessions originating from the same MAC address to protect itself from a DOS attack. This presents a problem for IWF PPPoE sessions because all PPPoE sessions originate from the same MAC address DSLAM. To overcome this issue, the IWF PPPoE tag is inserted at the DSLAM and read by the BRAS to distinguish the IWF PPPoE session from the regular PPPoE session during the PPPoE discovery frames.

For more information about this subject, refer to the DSL Forum Technical Report 101, "Migration to Ethernet-Based DSL Aggregation."

How to Configure PPP-Max-Payload and IWF PPPoE Tag Support

Enabling PPP-Max-Payload and IWF PPPoE Tag Support

To enable the PPP-Max-Payload and IWF PPPoE Tag Support feature, perform this task.

SUMMARY STEPS

1. **enable**
2. **configure terminal**
3. **bba-group pppoe** {*group-name* | **global**}
4. **virtual-template** *template-number*
5. **tag ppp-max-payload** [**minimum** *value* **maximum** *value*] [**deny**]
6. **sessions per-mac iwf limit** *per-mac-limit*
7. **interface** {**fastethernet** | **gigabitethernet** | **tengigabitethernet**} *slot /subslot/ port*[*subinterface*]
8. **pppoe enable** [**group** *group-name*]
9. **virtual-template** *template-number*
10. **ppp lcp echo mru verify** [**minimum** *value*]
11. **end**
12. **show pppoe session** [**all** | **packets**]

DETAILED STEPS

	Command or Action	Purpose
Step 1	enable Example: Router> enable	Enables privileged EXEC mode. • Enter your password if prompted.
Step 2	configure terminal Example: Router# configure terminal	Enters global configuration mode.
Step 3	bba-group pppoe { <i>group-name</i> global }	Enters BBA group configuration mode and defines a PPPoE profile.
	Example: Router(config)# bba-group pppoe pppoe-group	
Step 4	virtual-template <i>template-number</i> Example: Router(config-bba-group)# virtual-template 1	Configures a PPPoE profile with a virtual template to be used for cloning virtual access interfaces. • The <i>template-number</i> argument is an identifying number of the virtual template that will be used to clone virtual-access interfaces.
Step 5	tag ppp-max-payload [minimum <i>value</i> maximum <i>value</i>] [deny]	Specifies a range for the ppp-max payload tag value that will be accepted by the BRAS.

	Command or Action	Purpose
	<p>Example:</p> <pre>Router(config-bba-group)# tag ppp-max-payload minimum 1200 maximum 3000</pre>	<ul style="list-style-type: none"> • Default values are 1492 for the minimum and 1500 for the maximum. • The ppp-max-payload tag value accepted from the client cannot exceed the physical interface value for MTU minus 8.
Step 6	<p>sessions per-mac iwf limit <i>per-mac-limit</i></p> <p>Example:</p> <pre>Router(config-bba-group)# sessions per-mac iwf limit 200</pre>	<p>Specifies a limit for IWF-specific sessions per MAC address (separate from session limits that are not IWF-specific).</p> <ul style="list-style-type: none"> • If this command is not entered, the normal MAC-address session limit is applied to IWF sessions. • The <i>per-mac-limit</i> argument specifies the allowable number of IWF sessions. The default is 100.
Step 7	<p>interface {<i>fastethernet</i> <i>gigabitethernet</i> <i>tengigabitethernet</i>} <i>slot /subslot/ port[subinterface]</i></p> <p>Example:</p> <pre>Router(config-bba-group)# interface gigabitethernet 0/0/0</pre>	<p>Enters interface configuration mode for a Gigabit Ethernet interface.</p>
Step 8	<p>pppoe enable [group <i>group-name</i>]</p> <p>Example:</p> <pre>Router(config-if)# pppoe enable group 1</pre>	<p>Enables PPPoE sessions on an Ethernet interface or subinterface.</p>
Step 9	<p>virtual-template <i>template-number</i></p> <p>Example:</p> <pre>Router(config-if)# virtual-template 1</pre>	<p>Configures a PPPoE profile with a virtual template to be used for cloning virtual access interfaces.</p> <ul style="list-style-type: none"> • The <i>template-number</i> argument is an identifying number of the virtual template that will be used to clone virtual-access interfaces.
Step 10	<p>ppp lcp echo mru verify [minimum <i>value</i>]</p> <p>Example:</p> <pre>Router(config-if)# ppp lcp echo mru verify minimum 1304</pre>	<p>Verifies the negotiated MRU and adjusts the PPP virtual access interface MTU for troubleshooting purposes.</p> <ul style="list-style-type: none"> • If the optional minimum keyword is entered, the <i>value</i> can be from 64 to 1500. • If the verification of minimum MTU succeeds, the PPP connection's interface MTU is set to that value. This reset is useful when you troubleshoot and need to adjust the sessions according to underlying physical network capability. After this command is configured, IP Control Protocol (IPCP) is delayed until verification of the MTU is completed at the LCP.

	Command or Action	Purpose
Step 11	end Example: Router(config-if)# end	Exits the current configuration mode and returns to privileged EXEC mode.
Step 12	show pppoe session [all packets] Example: Router# show pppoe session all	Verifies the configuration and displays session information. <ul style="list-style-type: none"> • all --Displays output indicating if a session is IWF-specific or if the PPP-Max-Payload tag is in the discovery frame and accepted. • packets --Displays packet statistics for the PPPoE session.

Disabling PPP-Max-Payload and IWF PPPoE Tag Support

The **tag ppp-max-payload** command adjusts PPP MTU of the PPPoE session above the default maximum limit of 1492 bytes. But MTU values greater than 1492 can only be supported (with PPPoE) if the underlying Ethernet network supports these larger frames. Not all Ethernet networks support higher values. If your network does not support values higher than the default maximum, you should disable the PPP-Max-Payload and IWF PPPoE Tag Support feature by performing this task.

SUMMARY STEPS

1. **enable**
2. **configure terminal**
3. **bba-group pppoe {group-name | global}**
4. **tag ppp-max-payload deny**

DETAILED STEPS

	Command or Action	Purpose
Step 1	enable Example: Router> enable	Enables privileged EXEC mode. <ul style="list-style-type: none"> • Enter your password if prompted.
Step 2	configure terminal Example: Router# configure terminal	Enters interface configuration mode.

	Command or Action	Purpose
Step 3	bba-group pppoe { <i>group-name</i> global } Example: Router(config-if)# bba-group pppoe pppoe-group	Enters BBA group configuration mode and defines a PPPoE profile.
Step 4	tag ppp-max-payload deny Example: Router(config-bba-group)# tag ppp-max-payload deny	Disables the processing of the ppp-max-payload tag value higher than the default of 1492 bytes.

Configuration Examples for PPP-Max Payload and IWF PPPoE Tag Support

This section provides a sample configuration showing the PPP-Max-Payload and IWF PPPoE Tag Support feature enabled and a configuration in which the effects of this feature are disabled:

PPP-Max-Payload and IWF PPPoE Tag Support Enabled Example

The following configuration example shows the PPP-Max-Payload and IWF PPPoE Tag Support enabled to accept PPP-Max-Payload tag values from 1492 to 1892, limits the number of sessions per MAC address to 2000 when the IWF is present, and verifies that the PPP session can accept 1500-byte packets in both directions:

```
bba-group pppoe global
virtual-template 1
tag ppp-max-payload minimum 1492 maximum 1892
sessions per-mac limit 1
sessions per-mac iwf limit 2000
ppp lcp echo mru verify
!
interface Virtual-Template 1
!
```

PPP-Max-Payload and IWF PPPoE Tag Support Disabled Example

The following configuration example disables the effect of the **tag ppp-max-payload** command:

```
bba-group pppoe global
virtual-template 1
tag ppp-max-payload deny
```

Additional References

The following sections provide references related to the PPP-Max-Payload and IWF PPPoE Tag Support feature.

Related Documents

Related Topic	Document Title
Additional information about commands used in this document	<ul style="list-style-type: none"> • <i>Cisco IOS Broadband Access Aggregation and DSL Command Reference</i> • Cisco IOS Master Command List, All Releases

Standards

Standard	Title
DSL Forum Technical Report 101	Migration to Ethernet-Based DSL Aggregation

MIBs

MIB	MIBs Link
No new or modified MIBs are supported by this feature, and support for existing MIBs has not been modified by this feature.	To locate and download MIBs for selected platforms, Cisco IOS XE releases, and feature sets, use Cisco MIB Locator found at the following URL: http://www.cisco.com/go/mibs

RFCs

RFCs	Title
RFC 2516	A Method for Transmitting PPP Over Ethernet (PPPoE)
Draft RFC document	Accommodating an MTU/MRU Greater than 1492 in PPPoE

Technical Assistance

Description	Link
<p>The Cisco Support website provides extensive online resources, including documentation and tools for troubleshooting and resolving technical issues with Cisco products and technologies.</p> <p>To receive security and technical information about your products, you can subscribe to various services, such as the Product Alert Tool (accessed from Field Notices), the Cisco Technical Services Newsletter, and Really Simple Syndication (RSS) Feeds.</p> <p>Access to most tools on the Cisco Support website requires a Cisco.com user ID and password.</p>	<p>http://www.cisco.com/techsupport</p>

Feature Information for PPP-Max-Payload and IWF PPPoE Tag Support

The following table provides release information about the feature or features described in this module. This table lists only the software release that introduced support for a given feature in a given software release train. Unless noted otherwise, subsequent releases of that software release train also support that feature.

Use Cisco Feature Navigator to find information about platform support and Cisco software image support. To access Cisco Feature Navigator, go to www.cisco.com/go/cfn. An account on Cisco.com is not required.

Table 16: Feature Information for PPP-Max-Payload and IWF PPPoE Tag Support

Feature Name	Releases	Feature Information
PPP-Max Payload and IWF PPPoE Tag Support	Cisco IOS XE Release 2.3	<p>This feature was introduced on Cisco ASR 1000 Series Routers.</p> <p>This feature enables the PPP over Ethernet (PPPoE) component to process the PPP-Max-Payload and Interworking Functionality (IWF) PPPoE tags in the PPPoE discovery frame.</p> <p>The following commands were introduced or modified: ppp lcp echo mru verify, sessions per-mac iwf limit, show pppoe session, tag ppp-max-payload.</p>



CHAPTER 13

PPPoE Session Limiting on Inner QinQ VLAN

The PPPoE Session Limiting on Inner QinQ VLAN feature allows a service provider to limit each customer to one PPP over Ethernet (PPPoE) client in use by providing the ability to limit the number of PPPoE over QinQ (IEEE 802.1Q VLAN tunnel) sessions based on the inner VLAN ID configured under a subinterface. This capability eliminates the need to configure large numbers of subinterfaces.

- [Finding Feature Information, page 135](#)
- [Prerequisites for PPPoE Session Limiting on Inner QinQ VLAN, page 135](#)
- [Restrictions for PPPoE Session Limiting on Inner QinQ VLAN, page 136](#)
- [Information About PPPoE Session Limiting on Inner QinQ VLAN, page 136](#)
- [How to Configure PPPoE Session Limiting on Inner QinQ VLAN, page 137](#)
- [Configuration Examples for PPPoE Session Limiting on Inner QinQ VLAN, page 138](#)
- [Additional References, page 138](#)
- [Feature Information for PPPoE Session Limiting on Inner QinQ VLAN, page 140](#)

Finding Feature Information

Your software release may not support all the features documented in this module. For the latest caveats and feature information, see [Bug Search Tool](#) and the release notes for your platform and software release. To find information about the features documented in this module, and to see a list of the releases in which each feature is supported, see the feature information table.

Use Cisco Feature Navigator to find information about platform support and Cisco software image support. To access Cisco Feature Navigator, go to www.cisco.com/go/cfn. An account on Cisco.com is not required.

Prerequisites for PPPoE Session Limiting on Inner QinQ VLAN

- PPPoE server functionality must be configured.
- The PPPoE over IEEE 802.1Q VLANs feature must be configured.

Restrictions for PPPoE Session Limiting on Inner QinQ VLAN

- Do not configure the inner VLAN session limit to be greater than the outer session limit.

Information About PPPoE Session Limiting on Inner QinQ VLAN

Benefits of PPPoE Session Limiting on Inner QinQ VLAN

- Facilitates the ability to provision thousands of PPPoE over QinQ sessions having unique inner VLANs using simpler and easier to manage configurations.
- Allows service providers to limit PPPoE sessions based on the QinQ inner VLAN ID.

Feature Design of PPPoE Session Limiting on Inner QinQ VLAN

Prior to the PPPoE Session Limiting on Inner QinQ VLAN feature, PPPoE session limiting required a QinQ subinterface to be configured for each QinQ inner VLAN to be session limited, resulting in configuration requirements that did not scale to large numbers of QinQ VLAN ID pairs. The PPPoE Session Limiting on Inner QinQ VLAN feature adds broadband remote access server (BRAS) capability for configuring a single subinterface for all the unique inner VLAN IDs per outer VLAN while limiting one session per inner VLAN.

The figure below shows a typical implementation of the PPPoE Session Limiting on Inner QinQ VLAN feature.

Figure 13: PPPoE over QinQ Session Limiting

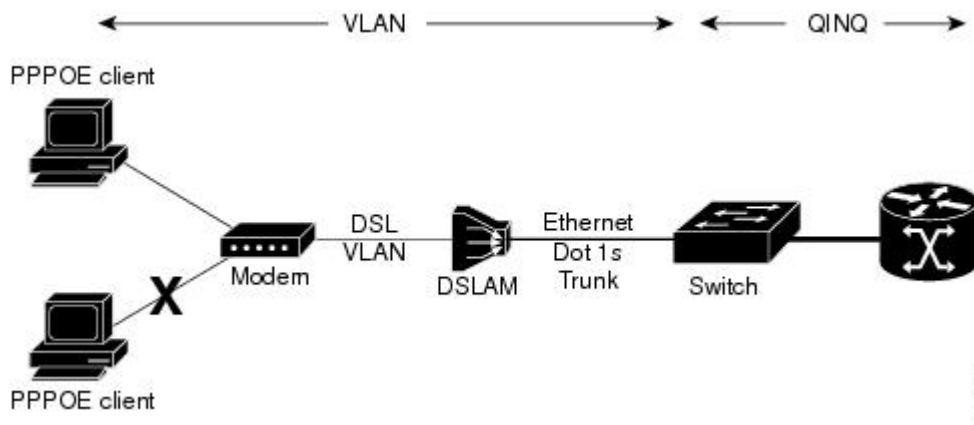

How to Configure PPPoE Session Limiting on Inner QinQ VLAN

Configuring PPPoE Session Limiting on Inner QinQ VLAN

Perform this task to configure PPPoE over QinQ session limiting and allows limiting, which allows you to limit the number of QinQ inner VLAN connections for each customer.

SUMMARY STEPS

1. `enable`
2. `configure terminal`
3. `bba-group pppoe group-name`
4. `sessions per-vlan limit outer-per-vlan-limit inner inner-per-vlan-limit`
5. `end`

DETAILED STEPS

	Command or Action	Purpose
Step 1	<p><code>enable</code></p> <p>Example:</p> <pre>Router> enable</pre>	<p>Enables privileged EXEC mode.</p> <ul style="list-style-type: none"> • Enter your password if prompted.
Step 2	<p><code>configure terminal</code></p> <p>Example:</p> <pre>Router# configure terminal</pre>	<p>Enters global configuration mode.</p>
Step 3	<p><code>bba-group pppoe group-name</code></p> <p>Example:</p> <pre>Router(config)# bba-group pppoe group 1</pre>	<p>Creates a PPPoE profile and enters the bba-group configuration mode.</p>
Step 4	<p><code>sessions per-vlan limit outer-per-vlan-limit inner inner-per-vlan-limit</code></p> <p>Example:</p> <pre>Router(config-bba-group)# sessions per-vlan-limit 400 inner 1</pre>	<p>Configures inner and outer VLAN limits.</p>

	Command or Action	Purpose
Step 5	end Example: Router(config-bba-group)# end	(Optional) Exits the current configuration mode and enters the privileged EXEC mode.

Troubleshooting Tips

The following commands can help troubleshoot PPPoE session limiting:

- debug pppoe error
- show pppoe session
- show pppoe summary

Configuration Examples for PPPoE Session Limiting on Inner QinQ VLAN

PPPoE Session Limiting on Inner QinQ VLAN Example

The following example shows how to enable PPPoE over QinQ session limiting on Fast Ethernet interface 1/0/0.1 with outer VLAN ID 10 and a unique inner VLAN ID for each session.

```
Router(config)# bba-group pppoe group1
Router(config-bba-group)# virtual-template 1
Router(config-bba-group)# sessions per-vlan limit 1000 inner 1
Router(config)#interface eth1/0/0.1
Router(config-subif)# encapsulation dot1q 10 second-dot1q any
Router(config-subif)# enable group group1
```

Additional References

The following sections provide references related to the PPPoE Session Limiting on Inner QinQ VLAN feature.

Related Documents

Related Topic	Document Title
Broadband access aggregation concepts	<i>Cisco IOS XE Broadband Access Aggregation and DSL Configuration Guide</i>

Related Topic	Document Title
Broadband access commands	<i>Cisco IOS Broadband Access Aggregation and DSL Command Reference</i>

Standards

Standard	Title
IEEE Standard 802.1Q	Virtual Bridged Local Area Networks

MIBs

MIB	MIBs Link
No new or modified MIBs are supported by this feature.	To locate and download MIBs for selected platforms, Cisco IOS XE software releases, and feature sets, use Cisco MIB Locator found at the following URL: http://www.cisco.com/go/mibs

RFCs

RFC	Title
RFC 2516	<i>PPP over Ethernet</i>

Technical Assistance

Description	Link
<p>The Cisco Support website provides extensive online resources, including documentation and tools for troubleshooting and resolving technical issues with Cisco products and technologies.</p> <p>To receive security and technical information about your products, you can subscribe to various services, such as the Product Alert Tool (accessed from Field Notices), the Cisco Technical Services Newsletter, and Really Simple Syndication (RSS) Feeds.</p> <p>Access to most tools on the Cisco Support website requires a Cisco.com user ID and password.</p>	http://www.cisco.com/techsupport

Feature Information for PPPoE Session Limiting on Inner QinQ VLAN

The following table provides release information about the feature or features described in this module. This table lists only the software release that introduced support for a given feature in a given software release train. Unless noted otherwise, subsequent releases of that software release train also support that feature.

Use Cisco Feature Navigator to find information about platform support and Cisco software image support. To access Cisco Feature Navigator, go to www.cisco.com/go/cfn. An account on Cisco.com is not required.

Table 17: Feature Information for PPPoE Session Limiting on Inner QinQ VLAN

Feature Name	Releases	Feature Information
PPPoE Session Limiting on Inner QinQ VLAN	Cisco IOS XE Release 2.1	<p>The PPPoE Session Limiting on Inner QinQ VLAN feature provides the ability to limit the number of PPPoE over QinQ, (IEEE 802.1Q VLAN tunnel) sessions based on the inner VLAN ID configured under a subinterface. In 12.2(31)SB2, this feature was introduced on the Cisco 10000 router.</p> <p>The following command was modified by this feature: session per-vlan limit.</p>



PPPoE Agent Remote-ID and DSL Line Characteristics Enhancement

The PPPoE Agent Remote-ID and DSL Line Characteristics Enhancement feature provides a method by which the digital subscriber line access multiplexer (DSLAM) sends the DSL Remote-ID tag in the discovery phase as an identifier for the authentication, authorization, and accounting (AAA) access request on an Fast or Gigabit Ethernet interface, thereby simulating ATM-based broadband access, but using cost-effective Fast or Gigabit Ethernet instead. This Remote-ID tag is useful for troubleshooting, authentication, and accounting.

- [Finding Feature Information, page 141](#)
- [Prerequisites for the PPPoE Agent Remote-ID and DSL Line Characteristics Enhancement, page 142](#)
- [Information About the PPPoE Agent Remote-ID and DSL Line Characteristics Enhancement, page 142](#)
- [How to Configure the PPPoE Agent Remote-ID and DSL Line Characteristics Enhancement, page 144](#)
- [Configuration Examples for PPPoE Agent Remote-ID and DSL Line Characteristics Enhancement, page 148](#)
- [Additional References, page 148](#)
- [Feature Information for PPPoE Agent Remote-ID and DSL Line Characteristics Enhancement, page 150](#)
- [Glossary, page 151](#)

Finding Feature Information

Your software release may not support all the features documented in this module. For the latest caveats and feature information, see [Bug Search Tool](#) and the release notes for your platform and software release. To find information about the features documented in this module, and to see a list of the releases in which each feature is supported, see the feature information table.

Use Cisco Feature Navigator to find information about platform support and Cisco software image support. To access Cisco Feature Navigator, go to www.cisco.com/go/cfn. An account on Cisco.com is not required.

Prerequisites for the PPPoE Agent Remote-ID and DSL Line Characteristics Enhancement

It is recommended that you be familiar with the following documents before configuring this feature:

- RFC 2516: [A Method for Transmitting PPP over Ethernet \(PPPoE\)](#)
- DSL Forum 2004-71: [Solution for a Remote-ID in PPPoE Discovery Phase](#)

See the [Additional References](#), on page 148 for more information.

Information About the PPPoE Agent Remote-ID and DSL Line Characteristics Enhancement

Differences Between ATM and Fast or Gigabit Ethernet-Based Broadband Access Networks

Broadband DSLAM and Broadband Remote Access Server (BRAS) vendors need to provide Fast or Gigabit Ethernet-based networks as an alternative to an ATM access network, with a DSLAM bridging the ATM-DSL local loop to the Fast or Gigabit Ethernet-based broadband access network and allowing Fast or Gigabit Ethernet-based connectivity to the BRAS. There is no unique mapping between the subscriber Line-ID tag and the interface in an Fast or Gigabit Ethernet broadband access network, as there is in an ATM-based broadband network, where the ATM VC is associated to a subscriber line. During the authentication phase that initiates the PPP access and AAA accounting requests, the BRAS includes a NAS-Port-ID attribute in RADIUS authentication packets that identifies the DSL for the subscriber

DSL Forum 2004-71 Solution for Remote-ID in PPPoE Discovery Phase

DSL Forum 2004-71 defines a method whereby the DSLAM sends the DSL Remote-ID tag in the PPP over Ethernet (PPPoE) discovery phase to apply the same subscriber mapping capability to Fast or Gigabit Ethernet interfaces that is possible on ATM interfaces. This method adds support for the PPPoE server acting as a BRAS to report the Remote-ID tag as a new vendor specific attribute (VSA) (AAA_AT_REMOTE_ID) in AAA authentication and accounting requests. If the **radius-server attribute 31 remote-id** command is configured on the BRAS, the Remote-ID tag will be sent to a RADIUS server as the Calling Station-ID tag (attribute 31).

Remote-ID Tag in Fast or Gigabit Ethernet-Based Broadband Access Networks

Traditional ATM-based DSL broadband access networks have the topology shown in The figure below.

Figure 14: ATM-Based DSL Broadband Access Network

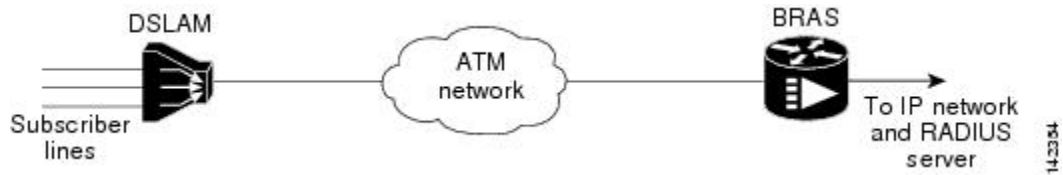

In terms of logical connectivity, there is a one-to-one mapping of the DSL subscriber line to the end user and the ATM virtual circuit (VC) used to carry the PPP session through the DSLAM and to the BRAS, where this VC information is converted into a NAS-Port-ID tag for use in RADIUS packets.

The simple mapping available from an ATM-based broadband network between the physical line in the DSL local loop to the end user and a virtual circuit (from DSLAM to BRAS) is not available for a Fast or Gigabit Ethernet-based network. To solve this problem, the PPPoE Remote-ID Tag Processing feature uses a PPPoE intermediate agent function on the DSLAM to attach a tag to the PPPoE discovery packets. The BRAS then receives the tagged packet, decodes the tag, and inserts the line identifier into RADIUS packets destined for the RADIUS server.

The DSLAM intercepts PPPoE discovery frames from the client or initiates a discovery frame if the PPPoE Active Discovery (PAD) client is a legacy PPP over ATM (PPPoA) device. The DSLAM inserts a unique Remote-ID tag and DSL sync rate tag using the PPPoE vendor-specific tag (0x0105) to PPPoE Active Discovery Initiation (PADI) and PPPoE Active Discovery Request (PADR) packets; see the figure below. The DSLAM forwards these packets upstream to the BRAS after the insertion. The tag contains the identification of the DSL line on which the PADI or PADR packet was received, in the access node where the intermediate agent resides.

Figure 15: PPPoE Remote-ID Tag Processing Solution

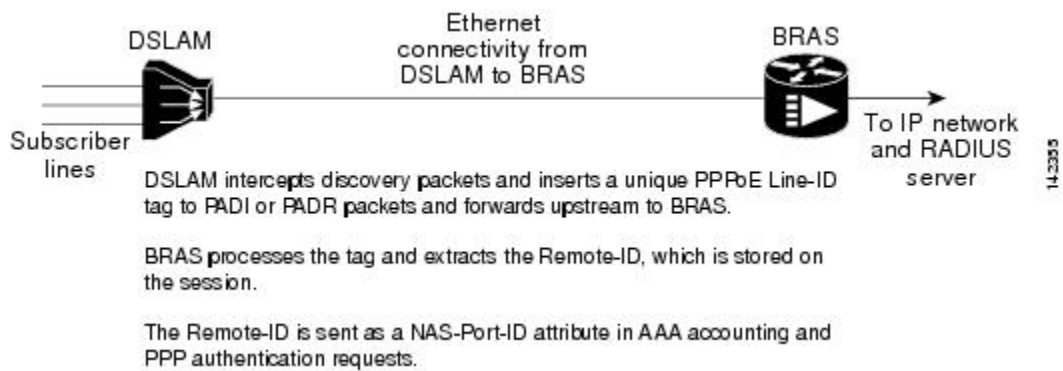

When the **vendor-tag remote-id service** command is configured in broadband access (BBA) group configuration mode, the BRAS processes the received PPPoE vendor-specific tag in the PADR frame and extracts the Remote-ID tag, which is sent to the remote AAA server as a VSA in all AAA access and accounting requests. When the **radius-server attribute 31 remote-id** global configuration command is also configured on the BRAS, the Remote-ID value is inserted into attribute 31.

Outgoing PAD Offer (PADO) and PAD Session-Confirmation (PADS) packets from the BRAS have the DSLAM-inserted Remote-ID tag. The DSLAM should strip the tag out of PADO and PADS frames. If the DSLAM cannot strip off the tag, the BRAS must remove the tag before sending the frames out. This is accomplished using the **vendor-tag strip** BBA group configuration mode command. If this command is configured under the BBA group, the BRAS strips the incoming Remote-ID tag (and any other vendor tag) off of the outgoing PADO and PADS frames. This action complies with DSL Forum Technical Report 101 .

Benefits of the PPPoE Agent Remote-ID and DSL Line Characteristics Enhancement

The shift toward Fast or Gigabit Ethernet-based DSLAMs offers the following benefits:

- Ability to use simpler and lower-cost provisioning options for DSL subscribers over a Fast or Gigabit Ethernet-based backhaul network rather than on an ATM-based network.
- Ability to use higher bandwidth connectivity options available from Fast or Gigabit Ethernet that are not possible on ATM.
- Ability to upgrade to next-generation DSLAMs with quality of service (QoS), and support for higher bandwidth, asymmetric dual latency modems such as the ADSL2.

Ability to inject high-bandwidth content such as video in a Fast or Gigabit Ethernet network.

How to Configure the PPPoE Agent Remote-ID and DSL Line Characteristics Enhancement

Configuring the PPPoE Agent Remote-ID and DSL Line Characteristics Enhancement Feature

This task describes how to configure the PPPoE Agent Remote-ID and DSL Line Characteristics Enhancement feature. When this feature is configured, BRAS will process the incoming PADR frames and send the Remote-ID field of the incoming tag to the RADIUS server as a VSA.

For DSL-Sync-Rate tags, you must enter the **vendor-tag dsl-sync-rate service** command under a BBA group. When this command is entered, the BRAS will process incoming PADR frames and send the DSL-Sync-Rate tags to the RADIUS server as VSAs.

An Access-Accept message is sent by the RADIUS server and vendor-tag attributes sent in the Access-Request message will be present in the Access-Accept message if the RADIUS server echoes it back.

SUMMARY STEPS

1. **enable**
2. **configure terminal**
3. **aaa new-model**
4. **radius-server attribute 31 remote-id**
5. **bba-group pppoe *group-name***
6. **vendor-tag remote-id service**
7. **vendor-tag dsl-sync-rate service**
8. **nas-port-id format c**
9. **end**

DETAILED STEPS

	Command or Action	Purpose
Step 1	<p>enable</p> <p>Example:</p> <pre>Router> enable</pre>	<p>Enables privileged EXEC mode.</p> <ul style="list-style-type: none"> • Enter your password if prompted.
Step 2	<p>configure terminal</p> <p>Example:</p> <pre>Router# configure terminal</pre>	<p>Enters global configuration mode.</p>
Step 3	<p>aaa new-model</p> <p>Example:</p> <pre>Router(config)# aaa new-model</pre>	<p>(Optional) Enables the AAA access control model.</p>
Step 4	<p>radius-server attribute 31 remote-id</p> <p>Example:</p> <pre>Router(config)# radius-server attribute 31 remote-id</pre>	<p>(Optional) Sends the Remote-ID tag to the RADIUS server via a new VSA (AAA_AT_REMOTE_ID) and in attribute 31--Calling Station ID.</p>
Step 5	<p>bba-group pppoe <i>group-name</i></p> <p>Example:</p> <pre>Router(config)# bba-group pppoe pppoe-group</pre>	<p>Defines a PPPoE profile and enters BBA group configuration mode.</p>

	Command or Action	Purpose
Step 6	vendor-tag remote-id service Example: Router(config-bba-group)# vendor-tag remote-id service	Enables the BRAS to process incoming PADR frames and send the Remote-ID field of the incoming tag to the RADIUS server as a VSA.
Step 7	vendor-tag dsl-sync-rate service Example: Router(config-bba-group)# vendor-tag dsl-sync-rate service	Enables the BRAS to process the incoming PADR frames and send the DSL-Sync-Rate tags to the RADIUS server as VSAs.
Step 8	nas-port-id format c Example: Router(config-bba-group)# nas-port-id format c	Specifies a format for broadband subscriber access line identification coding. <ul style="list-style-type: none"> The designation of format cis specifically designed for a particular coding format. A sample of this format is as follows: NAS_PORT_ID=atm 31/31/7:255.65535 example001/0/31/63/31/127 This means the subscriber interface type of the BRAS equipment is an ATM interface. The BRAS slot number is 31, and the BRAS subslot number is 31. The BRAS port number is 7. The virtual path identifier (VPI) is 255, and the virtual circuit identifier (VCI) is 65535. The Circuit-ID/Remote-ID tag is example001/0/31/63/31/127.
Step 9	end Example: Router(config-bba-group)# end	(Optional) Exits the current configuration mode and enters the privileged EXEC mode.

Stripping Vendor-Specific Tags

Outgoing PADO and PADS packets will have the DSLAM-inserted Remote-ID and DSL-Sync-Rate tags, and the DSLAM must strip these tags from the packets. If the DSLAM cannot strip the tag, the BRAS must remove it before sending out the packets. This task is accomplished through configuration of the **vendor-tag strip** command in BBA group configuration mode. Note that the **vendor-tag strip** command also removes the Circuit-ID tag.

SUMMARY STEPS

1. **enable**
2. **configure terminal**
3. **bba-group pppoe *group-name***
4. **vendor-tag strip**
5. **end**

DETAILED STEPS

	Command or Action	Purpose
Step 1	enable Example: Router> enable	Enables privileged EXEC mode. <ul style="list-style-type: none"> • Enter your password if prompted.
Step 2	configure terminal Example: Router# configure terminal	Enters global configuration mode.
Step 3	bba-group pppoe <i>group-name</i> Example: Router(config)# bba-group pppoe pppoe-group	Defines a PPPoE profile and enters BBA group configuration mode.
Step 4	vendor-tag strip Example: Router(config-bba-group)# vendor-tag strip	Enables the BRAS to strip off incoming vendor-specific tags (including Remote-ID, DSL-Sync-Rate tags, and Circuit-ID) from outgoing PADO and PADS frames.
Step 5	end Example: Router(config-bba-group)# end	(Optional) Exits the current configuration mode and enters the privileged EXEC mode.

Troubleshooting Tips

When you enter the **radius-server attribute 31 remote-id** global configuration command in the PPPoE Agent Remote-ID Tag and DSL Line Characteristics Enhancement feature configuration on the BRAS, you can use the **debug radius** privileged EXEC command to generate a report.

The report includes information about the:

- Incoming access interface
- Location where discovery frames are received
- Details of the sessions being established in PPPoE extended NAS-Port format (format d)

Configuration Examples for PPPoE Agent Remote-ID and DSL Line Characteristics Enhancement

Configuring PPPoE Agent Remote-ID and DSL Line Characteristics Enhancement Example

In the following example, outgoing PADO and PADS packets will retain the incoming Vendor-Specific Circuit-ID tag:

```
Router(config)# radius-server attribute 31 remote-id
!
Router(config)# bba-group pppoe rmt-id-tag
Router(config-bba-group)# vendor-tag remote-id service
Router(config-bba-group)# vendor-tag dsl-sync-rate service
Router(config-bba-group)# nas-port-id format c
!
Router(config)# interface FastEthernet0/0/0.1
Router(config-subif)# encapsulation dot1Q 120
Router(config-subif)# pppoe enable group rmt-id-tag
```

Stripping Vendor-Specific Tags Example

In the following example, the BRAS will strip off incoming Vendor-Specific Circuit-ID tags from outgoing PADO and PADS packets:

```
Router(config)# bba-group pppoe rmt-id-tag
Router(config-bba-group)# vendor-tag strip
Router(config)# interface FastEthernet0/0/0.1
Router(config-subif)# encapsulation dot1Q 120
Router(config-subif)# pppoe enable group rmt-id-tag
```

Additional References

The following sections provide references related to the PPPoE Agent Remote-ID and DSL Line Characteristics Enhancement feature.

Related Documents

Related Topic	Document Title
Configuring Broadband and DSL	<i>Cisco IOS XE Broadband and DSL Configuration Guide</i>

Related Topic	Document Title
RADIUS attributes	RADIUS Attributes Overview and RADIUS IETF Attributes module
DSL Line-ID tag solution	RFC 4679 - DSL Forum Vendor Specific RADIUS Attributes
Migration to Fast or Gigabit Ethernet-based DSL aggregation	DSL Forum Technical Report 101

Standards

Standard	Title
No new or modified standards are supported by this feature.	--

MIBs

MIB	MIBs Link
No new or modified MIBs are supported by this feature.	To locate and download MIBs for selected platforms, Cisco IOS XE software releases, and feature sets, use Cisco MIB Locator found at the following URL: http://www.cisco.com/go/mibs

RFCs

RFC	Title
RFC 2516	A Method for Transmitting PPP over Ethernet (PPPoE)

Technical Assistance

Description	Link
<p>The Cisco Support website provides extensive online resources, including documentation and tools for troubleshooting and resolving technical issues with Cisco products and technologies.</p> <p>To receive security and technical information about your products, you can subscribe to various services, such as the Product Alert Tool (accessed from Field Notices), the Cisco Technical Services Newsletter, and Really Simple Syndication (RSS) Feeds.</p> <p>Access to most tools on the Cisco Support website requires a Cisco.com user ID and password.</p>	<p>http://www.cisco.com/techsupport</p>

Feature Information for PPPoE Agent Remote-ID and DSL Line Characteristics Enhancement

The following table provides release information about the feature or features described in this module. This table lists only the software release that introduced support for a given feature in a given software release train. Unless noted otherwise, subsequent releases of that software release train also support that feature.

Use Cisco Feature Navigator to find information about platform support and Cisco software image support. To access Cisco Feature Navigator, go to www.cisco.com/go/cfn. An account on Cisco.com is not required.

Table 18: Feature Information for PPPoE Agent Remote-ID and DSL Line Characteristics Enhancement

Feature Name	Releases	Feature Information
PPPoE Agent Remote-ID and DSL Line Characteristics Enhancement	Cisco IOS XE Release 2.1.	<p>The PPPoE Agent Remote-ID and DSL Line Characteristics Enhancement feature provides a method by which the digital subscriber line access multiplexer (DSLAM) sends the DSL Remote-ID tag in the discovery phase as an identifier for the authentication, authorization, and accounting (AAA) access request on a Fast or Gigabit Ethernet interface, thereby simulating ATM-based broadband access, but using cost-effective Fast or Gigabit Ethernet instead. This Remote-ID tag is useful for troubleshooting, authentication, and accounting.</p> <p>The following commands were introduced or modified: radius-server attribute, bba-group pppoe group-name, vendor-tag remote-id service, vendor-tag dsl-sync-rate service, nas-port-id format c.</p>

Glossary

AAA --authentication, authorization, and accounting.

ATM --Asynchronous Transfer Mode.

BBA --broadband access.

BRAS --Broadband Remote Access Server.

DSLAM --digital subscriber line access multiplexer. A device that connects many digital subscriber lines to a network by multiplexing the DSL traffic onto one or more network trunk lines.

PADO --PPPoE Active Discovery Offer.

PADR --PPPoE Active Discovery Request.

PADS --PPPoE Active Discovery Session-Confirmation.

PPPoE --Point-to-Point Protocol over Ethernet.

RADIUS --Remote Authentication Dial-In User Service. Database for authenticating modem and ISDN connections and for tracking connection time.

VCI --virtual circuit identifier.

VLAN --virtual local-area network.

VPI --virtual path identifier.

VSA --vendor specific attribute. attribute that has been implemented by a particular vendor. It uses the attribute Vendor-Specific to encapsulate the resulting AV pair: essentially, Vendor-Specific = protocol:attribute = value.



Enabling PPPoE Relay Discovery and Service Selection Functionality

The PPPoE Relay feature enables an L2TP access concentrator (LAC) to relay active discovery and service selection functionality for PPP over Ethernet (PPPoE), over a Layer 2 Tunneling Protocol (L2TP) control channel, to an L2TP network server (LNS) or tunnel switch (multihop node). The relay functionality of this feature allows the LNS or tunnel switch to advertise the services it offers to the client, thereby providing end-to-end control of services between the LNS and a PPPoE client.

- [Finding Feature Information, page 153](#)
- [Prerequisites for Enabling PPPoE Relay Discovery and Service Selection Functionality, page 154](#)
- [Information About Enabling PPPoE Relay Discovery and Service Selection Functionality, page 154](#)
- [How to Enable PPPoE Relay Discovery and Service Selection Functionality, page 154](#)
- [Configuration Examples for Enabling PPPoE Relay Discovery and Service Selection Functionality, page 159](#)
- [Additional References, page 163](#)
- [Feature Information for Enabling PPPoE Relay Discovery and Service Selection Functionality, page 165](#)

Finding Feature Information

Your software release may not support all the features documented in this module. For the latest caveats and feature information, see [Bug Search Tool](#) and the release notes for your platform and software release. To find information about the features documented in this module, and to see a list of the releases in which each feature is supported, see the feature information table.

Use Cisco Feature Navigator to find information about platform support and Cisco software image support. To access Cisco Feature Navigator, go to www.cisco.com/go/cfn. An account on Cisco.com is not required.

Prerequisites for Enabling PPPoE Relay Discovery and Service Selection Functionality

- You must understand the concepts described in the "Preparing for Broadband Access Aggregation" module.
- PPPoE sessions must be established using the procedures in the "Providing Protocol Support for Broadband Access Aggregation of PPPoE Sessions" module.
- This document assumes you understand how to configure a virtual private dialup network (VPDN) tunnel and a tunnel switch.

Information About Enabling PPPoE Relay Discovery and Service Selection Functionality

L2TP Active Discovery Relay for PPPoE

The PPPoE protocol described in RFC 2516 defines a method for active discovery and service selection of devices in the network by an LAC. A PPPoE client uses these methods to discover an access concentrator in the network, and the access concentrator uses these methods to advertise the services it offers.

The PPPoE Relay feature allows the active discovery and service selection functionality to be offered by the LNS, rather than just by the LAC. The PPPoE Relay feature implements the Network Working Group Internet-Draft titled *L2TP Active Discovery Relay for PPPoE*. The Internet-Draft describes how to relay PPPoE Active Discovery (PAD) and Service Relay Request (SRRQ) messages over an L2TP control channel (the tunnel).

The key benefit of the PPPoE Relay feature is end-to-end control of services between the LNS and a PPPoE client.

How to Enable PPPoE Relay Discovery and Service Selection Functionality

Configuring the LAC and Tunnel Switch for PPPoE Relay

Perform this task to configure the LAC and tunnel switch for PPPoE Relay, which configures a subscriber profile that directs PAD messages to be relayed on an L2TP tunnel. The subscriber profile also will contain an authorization key for the outgoing L2TP tunnel.

SUMMARY STEPS

1. **enable**
2. **configure terminal**
3. **subscriber profile** *profile-name*
4. **service relay pppoe vpdn group** *vpdn-group-name*
5. **exit**

DETAILED STEPS

	Command or Action	Purpose
Step 1	enable Example: Router> enable	Enables privileged EXEC mode. <ul style="list-style-type: none"> • Enter your password if prompted.
Step 2	configure terminal Example: Router# configure terminal	Enters global configuration mode.
Step 3	subscriber profile <i>profile-name</i> Example: Router(config)# subscriber profile profile-1	Configures the subscriber profile name and enters subscriber profile configuration mode. <ul style="list-style-type: none"> • <i>profile-name</i> --Is referenced from a PPPoE profile configured by the bba-group pppoe global configuration command, so that all the PPPoE sessions using the PPPoE profile defined by the bba-group pppoe command will be treated according to the defined subscriber profile.
Step 4	service relay pppoe vpdn group <i>vpdn-group-name</i> Example: Router(config-sss-profile)# service relay pppoe vpdn group Group-A	Provides PPPoE relay service using a VPDN L2TP tunnel for the relay. The VPDN group name specified is used to obtain outgoing L2TP tunnel information. <ul style="list-style-type: none"> • See the What to Do Next, on page 156 section for the equivalent RADIUS profile entry.
Step 5	exit Example: Router(config-sss-profile)# exit	(Optional) Ends the configuration session and returns to privileged EXEC mode.

What to Do Next

Configure the LNS side of the configuration by performing the tasks described in the next section.

Configuring the LNS (or Multihop Node) to Respond to Relayed PAD Messages

On the router that responds to relayed PAD messages, perform this task to configure a PPPoE group and attach it to a VPDN group that accepts dial-in calls for L2TP. The relayed PAD messages will be passed from the VPDN L2TP tunnel and session to the PPPoE broadband group for receiving the PAD responses.

SUMMARY STEPS

1. **enable**
2. **configure terminal**
3. **vpdn-group** *vpdn-group-name*
4. **accept-dialin**
5. **protocol l2tp**
6. **virtual-template** *template-number*
7. **exit**
8. **terminate-from hostname** *host-name*
9. **relay pppoe bba-group** *pppoe-bba-group-name*
10. **exit**

DETAILED STEPS

	Command or Action	Purpose
Step 1	enable Example: Router> enable	Enables privileged EXEC mode. <ul style="list-style-type: none"> • Enter your password if prompted.
Step 2	configure terminal Example: Router# configure terminal	Enters global configuration mode.
Step 3	vpdn-group <i>vpdn-group-name</i> Example: Router(config)# vpdn-group Group-A	Creates a VPDN group and enters VPDN group configuration mode.

	Command or Action	Purpose
Step 4	accept-dialin Example: Router(config-vpdn)# accept-dialin	Configures the LNS to accept tunneled PPP connections from an LAC and creates an accept-dialin VPDN subgroup.
Step 5	protocol l2tp Example: Router(config-vpdn-req-in)# protocol l2tp	Specifies the L2TP tunneling protocol.
Step 6	virtual-template <i>template-number</i> Example: Router(config-vpdn-req-in)# virtual-template 2	Specifies which virtual template will be used to clone virtual access interfaces.
Step 7	exit Example: Router(config-vpdn-req-in)# exit	Exits to VPDN group configuration mode.
Step 8	terminate-from hostname <i>host-name</i> Example: Router(config-vpdn)# terminate-from hostname LAC-1	Specifies the LAC hostname that will be required when the VPDN tunnel is accepted.
Step 9	relay pppoe bba-group <i>pppoe-bba-group-name</i> Example: Router(config-vpdn)# relay pppoe bba-group group-2	Specifies the PPPoE BBA group that will respond to the PAD messages. <ul style="list-style-type: none"> • The PPPoE BBA group name is defined with the bba-group pppoe <i>group-name</i> global configuration command.
Step 10	exit Example: Router(config-vpdn)# exit	Exits to global configuration mode.

Monitoring PPPoE Relay

Perform this task to monitor PPPoE Relay.

SUMMARY STEPS

1. **enable**
2. **show pppoe session**
3. **show pppoe relay context all**
4. **clear pppoe relay context**

DETAILED STEPS**Step 1****enable**

Enables privileged EXEC mode.

- Enter your password if prompted.

Example:

```
Router> enable
```

Step 2**show pppoe session**

Displays information about currently active PPPoE sessions.

Example:

```
Router# show pppoe session
  1 session in FORWARDED (FWDED) State
  1 session total
Uniq ID  PPPoE  RemMAC          Port          VT  VA          State
      SID  LocMAC
    26   19   0001.96da.a2c0  Et0/0.1       5  N/A  RELFWD
      000c.8670.1006  VLAN:3434
```

Step 3**show pppoe relay context all**

Displays the PPPoE relay context created for relaying PAD messages.

Example:

```
Router# show pppoe relay context all
Total PPPoE relay contexts 1
UID  ID      Subscriber-profile  State
25   18      cisco.com          RELAYED
```

Example:**Step 4****clear pppoe relay context**

This command clears the PPPoE relay context created for relaying PAD messages.

Example:

```
Router(config)# clear pppoe relay context
```

Troubleshooting Tips

Use the following commands in privileged EXEC mode to help you troubleshoot the PPPoE Relay feature:

- **debug ppp forwarding**
- **debug ppp negotiation**
- **debug pppoe events**
- **debug pppoe packets**
- **debug vpdn l2x-events**
- **debug vpdn l2x-packets**

Configuration Examples for Enabling PPPoE Relay Discovery and Service Selection Functionality

PPPoE Relay on LAC Configuration Example

The following is an example of a standard LAC configuration with the commands to enable PPPoE relay added:

```
hostname User2
!
username User1 password 0 field
username User2 password 0 field
username user-group password 0 field
username User5 password 0 field
username User2-lac-domain password 0 field
username User1-client-domain@cisco.net password 0 field
username User3-lns-domain password 0 field
!
ip domain-name cisco.com
!
vpdn enable
vpdn source-ip 10.0.195.151
!
vpdn-group User2-vpdn-group-domain
 request-dialin
  protocol l2tp
  domain cisco.net
 initiate-to ip 10.0.195.133
 local name User2-lac-domain
!
!
interface Loopback123
 ip address 10.22.2.2 255.255.255.0
!
interface Ethernet0/0
 ip address 10.0.195.151 255.255.255.0
 no keepalive
 half-duplex
 pppoe enable group group-1
```

```

no cdp enable
!
interface Virtual-Template1
mtu 1492
ip unnumbered Loopback123
ppp authentication chap
ppp chap hostname User2-lac-domain
!
ip route 0.0.0.0 0.0.0.0 10.0.195.1
!
!
subscriber profile Profile1
service relay pppoe vpdn group User2-vpdn-group-domain
!
bba-group pppoe group-1
virtual-template 1
service profile Profile1
!

```

Basic LNS Configured for PPPoE Relay Example

The following example shows the basic configuration for an LNS with commands added for PPPoE relay:

```

hostname User5
!
!
username User5 password 0 field
username user-group password 0 field
username User1 password 0 field
username User2 password 0 field
username User3 password 0 field
username User3-dialout password 0 cisco
username User2-dialout password 0 cisco
username abc password 0 cisco
username dial-7206a password 0 field
username mysgbpgroup password 0 cisco
username User3-lns-domain password 0 field
username User2-lac-domain password 0 field
username User1-client-domain@cisco.net password 0 field
username User5-mh password 0 field
username User1@domain.net password 0 field
ip subnet-zero
!
!
ip domain-name cisco.com
!
vpdn enable
vpdn multihop
vpdn source-ip 10.0.195.133
!
vpdn-group 1
request-dialin
protocol l2tp
!
vpdn-group 2
! Default L2TP VPDN group
accept-dialin
protocol l2tp
!
vpdn-group User5-mh
request-dialin
protocol l2tp
domain cisco.net
initiate-to ip 10.0.195.143
local name User5-mh
!
vpdn-group User3-vpdn-group-domain
accept-dialin
protocol l2tp

```



```

    virtual-template 2
    terminate-from hostname User2-lac-domain
    local name User3-lns-domain
    relay pppoe group group-1
    !
    !
interface Loopback0
    no ip address
    !
    !
interface Loopback123
    ip address 10.23.3.2 255.255.255.0
    !
    !
interface FastEthernet0/0
    ip address 10.0.195.133 255.255.255.0
    duplex auto
    speed auto
    no cdp enable
    !
    !
interface Virtual-Template2
    mtu 1492
    ip unnumbered Loopback123
    ip access-group virtual-access3#234 in
    ppp mtu adaptive
    ppp authentication chap
    ppp chap hostname User3-lns-domain
    !
    !
ip default-gateway 10.0.195.1
ip classless
ip route 0.0.0.0 0.0.0.0 10.0.195.1
    !
    !
bba-group pppoe group-1
    virtual-template 2
    !

```

Tunnel Switch (or Multihop Node) Configured to Respond to PAD Messages Example

The following is an example of a standard tunnel switch configuration with the commands to enable response to PPPoE relay messages added:

```

hostname User3
!
!
username User1 password 0 room1
username User2 password 0 room1
username User3 password 0 room1
username User1@domain.net password 0 room1
username User3-lns-dnis password 0 cisco
username User3-lns-domain password 0 room1
username User2-lac-dnis password 0 cisco
username User2-lac-domain password 0 room1
username User5 password 0 room1
username User5-mh password 0 room1
username user-group password 0 room1
username User3-dialout password 0 cisco
username User2-dialout password 0 cisco
username abc password 0 cisco
username dial-7206a password 0 room1
username msgbpgroup password 0 cisco
username User1-client-domain@cisco.net password 0 room1
username User4-lns-domain password 0 room1
!

```

Tunnel Switch Configured to Relay PAD Messages Example

```

ip domain-name cisco.com
!
vpdn enable
!
vpdn-group User3-mh
  accept-dialin
  protocol l2tp
  virtual-template 1
  terminate-from hostname User5-mh
  relay pppoe bba-group group-1
!
interface Loopback0
  ip address 10.4.4.2 255.255.255.0
!
interface Loopback1
  ip address 10.3.2.2 255.255.255.0
!
interface Ethernet2/0
  ip address 10.0.195.143 255.255.0.0
  half-duplex
  no cdp enable
!
interface Virtual-Template1
  mtu 1492
  ip unnumbered Loopback0
  no keepalive
  ppp mtu adaptive
  ppp authentication chap
  ppp chap hostname User3-lns-domain
!
ip default-gateway 10.0.195.1
ip route 0.0.0.0 0.0.0.0 10.0.195.1
!
!
bba-group pppoe group-1
  virtual-template 1
!

```

Tunnel Switch Configured to Relay PAD Messages Example

The following partial example shows a configuration that allows the tunnel switch to relay PAD messages:

```

subscriber profile profile-1
! Configure profile for PPPoE Relay
  service relay pppoe vpdn group Example1.net
.
.
.
vpdn-group Example2.net
! Configure L2TP tunnel for PPPoE Relay
  accept-dialin
  protocol l2tp
.
.
.
  terminate-from host Host1
  relay pppoe bba-group group-1
.
.
.
vpdn-group Example1.net
! Configure L2TP tunnel for PPPoE Relay
  request-dialin
  protocol l2tp
.
.
.
  initiate-to ip 10.17.1.3
.

```

```

.
.
! PPPoE-group configured for relay
bba-group pppoe group-1
.
.
.
service profile profile-1

```

RADIUS Subscriber Profile Entry for the LAC Example

The following example shows how to enter Subscriber Service Switch subscriber service attributes in a AAA RADIUS server profile.

```

profile-1 = profile-name.
.
Cisco:Cisco-Avpair = "sss:sss-service=relay-pppoe"

```

The following is an example of a typical RADIUS subscriber profile entry for an LAC:

```

cisco.com Password = "password"
Cisco:Cisco-Avpair = "sss:sss-service=relay-pppoe",
Tunnel-Type = L2TP,
Tunnel-Server-Endpoint = . . . . .,
Tunnel-Client-Auth-ID = "client-id",
Tunnel-Server-Auth-ID = "server-id",
Cisco:Cisco-Avpair = "vpdn:l2tp-tunnel-password=password",
Cisco:Cisco-Avpair = "vpdn:l2tp-nosession-timeout=never",
Tunnel-Assignment-Id = assignment-id

```

RADIUS VPDN Group User Profile Entry for the LNS Example

The following example shows how to enter the VPDN group attributes in a AAA RADIUS server profile.

```

profile-1 = profile-name.
.
.
Cisco:Cisco-Avpair = "vpdn:relay-pppoe-bba-group=group-name"

```

The following is an example of a typical RADIUS subscriber profile entry for an LNS:

```

cisco.com Password = "password"
Tunnel-Type = L2TP,
Tunnel-Server-Endpoint = . . . . .,
Tunnel-Client-Auth-ID = "client-id",
Tunnel-Server-Auth-ID = "server-id",
Cisco:Cisco-Avpair = "vpdn:l2tp-tunnel-password=password",
Cisco:Cisco-Avpair = "vpdn:l2tp-nosession-timeout=never",
Cisco:Cisco-Avpair = "vpdn:relay-pppoe-bba-group=group-name"
Tunnel-Assignment-Id = assignment-id

```

Additional References

The following sections provide referenced related to the PPPoE Relay feature.

Related Documents

Related Topic	Document Title
VPDN tunnels	<i>Cisco IOS XE Dial Technologies Configuration Guide</i>
VPDN tunnel commands	<i>Cisco IOS XE Dial Technologies Configuration Guide</i>
Tunnel switching	L2TP Tunnel Switching feature module
PPPoE broadband groups	<i>Cisco IOS XE Broadband Access Aggregation and DSL Configuration Guide</i>
PPPoE broadband commands	<i>Cisco IOS XE Broadband Access Aggregation and DSL Command Reference</i>
Broadband access aggregation concepts	<i>Cisco IOS XE Broadband Access Aggregation and DSL Configuration Guide</i>
Tasks for preparing for broadband access aggregation	<i>Cisco IOS XE Broadband Access Aggregation and DSL Configuration Guide</i>

Standards

Standards	Title
None	--

MIBs

MIBs	MIBs Link
None	To locate and download MIBs for selected platforms, Cisco IOS XE software releases, and feature sets, use Cisco MIB Locator found at the following URL: http://www.cisco.com/go/mibs

RFCs

RFCs	Title
RFC 2516	<i>Method for Transmitting PPP Over Ethernet (PPPoE)</i>

RFCs	Title
RFC 3817	<ul style="list-style-type: none"> • <i>L2TP Active Discovery Relay for PPPoE</i> • Network Working Group Internet-Draft, <i>L2TP Active Discovery Relay for PPPoE</i>, which can be seen at http://tools.ietf.org/html/draft-dasilva-l2tp-relaysvc-06

Technical Assistance

Description	Link
<p>The Cisco Support website provides extensive online resources, including documentation and tools for troubleshooting and resolving technical issues with Cisco products and technologies.</p> <p>To receive security and technical information about your products, you can subscribe to various services, such as the Product Alert Tool (accessed from Field Notices), the Cisco Technical Services Newsletter, and Really Simple Syndication (RSS) Feeds.</p> <p>Access to most tools on the Cisco Support website requires a Cisco.com user ID and password.</p>	http://www.cisco.com/techsupport

Feature Information for Enabling PPPoE Relay Discovery and Service Selection Functionality

The following table provides release information about the feature or features described in this module. This table lists only the software release that introduced support for a given feature in a given software release train. Unless noted otherwise, subsequent releases of that software release train also support that feature.

Use Cisco Feature Navigator to find information about platform support and Cisco software image support. To access Cisco Feature Navigator, go to www.cisco.com/go/cfn. An account on Cisco.com is not required.

Table 19: Feature Information for Enabling PPPoE Relay Discovery and Service Selection Functionality

Feature Name	Releases	Feature Configuration Information
PPPoE Relay	Cisco IOS XE Release 2.1	The PPPoE Relay feature enables an L2TP access concentrator (LAC) to relay active discovery and service selection functionality for PPP over Ethernet (PPPoE), over a Layer 2 Tunneling Protocol (L2TP) control channel, to an L2TP network server (LNS) or tunnel switch (multihop node). This feature was integrated into Cisco IOS XE Release 2.1.
PPPoE Service Selection	Cisco IOS XE Release 2.4	This feature was integrated into Cisco IOS XE Release 2.4.



Configuring Cisco Subscriber Service Switch Policies

The Subscriber Service Switch provides the framework for the management and scalability of PPP sessions that are switched from one virtual PPP link to another. It gives Internet service providers (ISPs) the flexibility to determine which services to provide to subscribers, the number of subscribers, and how to define the services. The primary focus of the Subscriber Service Switch is to direct PPP from one point to another using a Layer 2 subscriber policy. The policy manages tunneling of PPP in a policy-based bridging fashion.

- [Finding Feature Information, page 167](#)
- [Prerequisites for Configuring a Subscriber Service Switch Policy, page 168](#)
- [Restrictions for Configuring a Subscriber Service Switch Policy, page 168](#)
- [Information About the Subscriber Service Switch, page 168](#)
- [How to Configure a Subscriber Service Switch Policy, page 173](#)
- [Configuration Examples for Configuring a Subscriber Service Switch Policy, page 178](#)
- [Where to Go Next, page 191](#)
- [Additional References, page 192](#)
- [Feature Information for Configuring a Subscriber Service Switch Policy, page 193](#)

Finding Feature Information

Your software release may not support all the features documented in this module. For the latest caveats and feature information, see [Bug Search Tool](#) and the release notes for your platform and software release. To find information about the features documented in this module, and to see a list of the releases in which each feature is supported, see the feature information table.

Use Cisco Feature Navigator to find information about platform support and Cisco software image support. To access Cisco Feature Navigator, go to www.cisco.com/go/cfn. An account on Cisco.com is not required.

Prerequisites for Configuring a Subscriber Service Switch Policy

- Before configuring a Subscriber Service Switch policy, you must understand the concepts presented in the "Understanding Broadband Access Aggregation" module.
- Before configuring a Subscriber Service Switch policy, you must perform the PPP over Ethernet (PPPoE) configuration procedures in the "Providing Protocol Support for Broadband Access Aggregation of PPPoE Sessions" module or perform the PPP over ATM (PPPoA) configuration procedures in the "Providing Protocol Support for Broadband Access Aggregation of PPP over ATM Sessions" module.

Restrictions for Configuring a Subscriber Service Switch Policy

The Subscriber Service Switch provides the framework for the management and scalability of PPP sessions that are switched from one virtual PPP link to another. The Subscriber Server Switch provides the infrastructure for any protocol to plug into; however, the initial implementation provides switching PPP over Ethernet and PPP over ATM session to a Layer 2 Tunneling Protocol (L2TP) device such as an L2TP access concentrator (LAC) switch, and switching L2TP sessions to an L2TP tunnel switch only.

Information About the Subscriber Service Switch

The Subscriber Service Switch was developed in response to a need by Internet service providers (ISPs) for increased scalability and extensibility for remote access service selection and Layer 2 subscriber policy management. This Layer 2 subscriber policy is needed to manage tunneling of PPP in a policy-based bridging fashion.

Benefits of the Subscriber Service Switch

The Subscriber Service Switch provides the framework for the management and scalability of PPP sessions that are switched from one virtual PPP link to another. It gives Internet service providers (ISPs) the flexibility to determine which services to provide to subscribers, the number of subscribers, and how to define the services. In the past, remote access service selection was largely determined by the telephone number dialed or the PPP username and password entered during a PPP authentication cycle. However, broadband, cable, Virtual Private Network (VPN), and wireless access methods have created an environment where PPP sessions may be tunneled over a variety of protocols and media. The multitude of protocols, management domains, network infrastructure, and variety of services has created a complex environment for directing a subscriber to a given service or application. The problem is further complicated by the much greater density of total PPP sessions that can be transported over shared media versus traditional point-to-point links. The Subscriber Service Switch can provide a flexible and extensible decision point linking an incoming subscriber (typically a PPP session over some physical or virtual link) to another tunneled link or local termination for Layer 3 processing.

The Subscriber Service Switch is also scalable in situations where a subscriber's Layer 2 service is switched across virtual links. Examples include switching among PPPoA, PPPoE, L2TP, Layer 2 Forwarding Protocol

(L2F), Point-to-Point Tunneling Protocol (PPTP), generic routing encapsulation (GRE), and General Packet Radio Service (GPRS) Tunneling Protocol (GTP wireless data standard).

The figure below shows how the Subscriber Service Switch provides its own centralized switching path that bypasses the virtual-access-based switching available earlier. In the figure below, the Subscriber Service Switch is switching data traffic from personal computers in a home and corporate office and from a wireless user.

Figure 16: Basic Subscriber Service Switch Operation

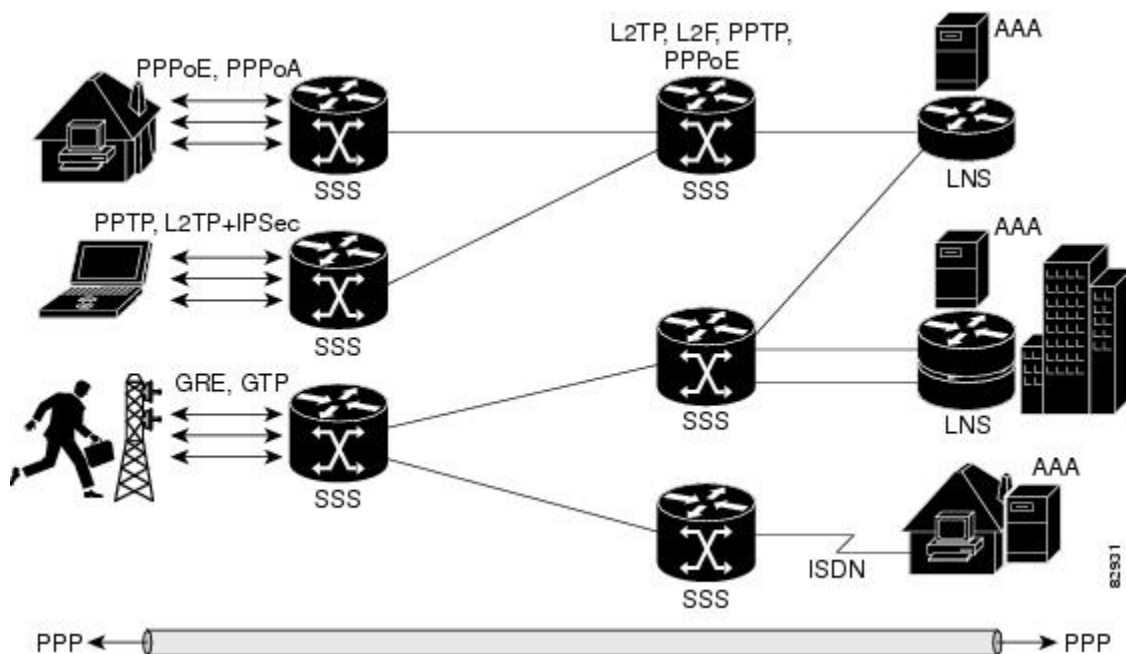

Protocols that register with the Subscriber Service Switch application programming interface (API) can take advantage of this switching path. Bypassing the virtual access interface in this manner helps the Cisco IOS XE software to scale to the increased number of sessions that the market demands. The Subscriber Service Switch also improves network performance. For example, benchmark testing indicates that performance of L2TP multihop tasks occurs twice as fast in networks with the Subscriber Service Switch as in networks without it.

Backward Compatibility of Subscriber Service Switch Policies

All of the existing virtual private dialup network (VPDN), Multichassis Multilink PPP (MMLP), and local termination policies and configurations are maintained in the implementation of the Subscriber Service Switch; however, default policies may be overridden by the following configurations or events:

- Resource Manager (RM) VPDN authorization is attempted before VPDN authorization.
- VPDN authorization is attempted before Stack Group Forwarding (SGF) MMLP.
- VPDN service authorization is attempted only when the **vpdn enable** command is configured.
- RM VPDN service authorization is attempted only if RM is enabled.

- SGF authorization is attempted only when the **sgbp member** command is configured and one or both of the following service keys are available from the subscriber: unauthenticated PPP name and endpoint discriminator.
- The **dnis** and **domain** service keys, in that order, are used to authorize VPDN service, provided that VPDN service is enabled.
- An unauthenticated PPP name is always reduced to a domain name by taking all characters from the right of the PPP name up to a configurable delimiter character (default is the @ character). Only the domain portion is used to locate a service.
- If the **vpdn authen-before-forward** command is configured as a global configuration command, the authenticated PPP name is used to authorize VPDN service.
- The **vpdn-group** command can define four configurations:
 - Authorization for VPDN call termination (using the *accept-dialin* and **accept-dialout** keywords).
 - Authorization for VPDN subscriber service (using the **request-dialin** and **request-dialout** keywords).
 - A directive to collect further service keys and reauthorize (using the **authen-before-forward** keyword).
 - A tunnel configuration.

The Subscriber Service Switch adds a general configuration framework to replace the first three aspects of a VPDN group.

- If VPDN and SGF services either are not configured or cannot be authorized, local PPP termination service is selected. Further PPP authorization is still required to complete local termination.
- A two-phase authorization scheme is enabled by the **vpn domain authorization** command. An NAS-Port-ID (NAS port identifier) key is used to locate the first service record, which contains a restricted set of values for the domain substring of the unauthenticated PPP name. This filtered service key then locates the final service. Cisco refers to this scheme as domain preauthorization.
- Domain preauthorization will occur only when the **NAS-Port-ID** key is available.
- When domain preauthorization is enabled, both authenticated and unauthenticated domain names are checked for restrictions.
- It is possible to associate a fixed service with an ATM permanent virtual circuit (PVC), thus affecting any subscribers carried by the PVC. The **vpn service** command, in ATM VC or VC class configuration mode, and the associated key make up the generic service key.
- When the generic service key is available, it will be used for authorization instead of the unauthenticated domain name.
- If either the **vpdn authen-before-forward** or **per vpdn-group authen-before-forward** command is configured, the authenticated username is required and will be used to authorize VPDN service.
- To determine whether the **authen-before-forward** command is configured in a VPDN group (using the **vpdn-group** command), an unauthenticated username or the generic service key is required as the initial-want key set.
- When the global **vpdn authen-before-forward** command is not configured, the generic service key, if one is available, is used to determine whether the **authen-before-forward** function is configured in the VPDN group (using the **vpdn-group** command). If the generic service key is not available, the unauthenticated username will be used.

- If an accounting-enabled key is available, the unauthenticated username is required.
- VPDN multihop is allowed only when VPDN multihop is enabled.
- SGF on the L2TP network server (LNS) is allowed only when VPDN multihop is enabled on the LNS.
- Forwarding of SGF calls on the LAC is allowed only if VPDN multihop is enabled on the LAC.
- SGF-to-SGF multihop is not allowed.
- When PPP forwarding is configured, both Multilink PPP (MLP) and non-MLP calls are forwarded to the winner of the Stack Group Bidding Protocol (SGBP) bid.
- Authentication is always required for forwarded Packet Data Serving Node (PDSN) calls.
- When the **directed-request** function is enabled and activated using the **ip host** command, VPDN service authorization occurs only when the **vpdn authorize directed-request** command is used.
- Fixed legacy policy is still maintained for RM.

Debug Commands Available for Subscriber Service Switch

The Subscriber Service Switch feature introduces five new EXEC mode **debug** commands to enable diagnostic output about Subscriber Service Switch call operation, as follows:

- **debug sss aaa authorization event** --Displays messages about AAA authorization events that are part of normal call establishment.
- **debug sss aaa authorization fsm** --Displays messages about AAA authorization state changes.
- **debug sss error** --Displays diagnostic information about errors that may occur during Subscriber Service Switch call setup.
- **debug sss event** --Displays diagnostic information about Subscriber Service Switch call setup events.
- **debug sss fsm** --Displays diagnostic information about the Subscriber Service Switch call setup state.

The following EXEC mode debug commands already exist:

- **debug redundancy** - This command is available on platforms that support redundancy.
- **debug sss elog** --Collects SSS performance event data.
- **debug sss feature** --Enables debug for SSS feature events
- **debug sss packet** --Enables packet level event and information debugging for the Subscriber Service Switch.
- **debug sss policy** --Enables debug for SSS policy module events.
- **debug sss service** --Enables debug for service manager event.

These commands were designed to be used with **debug** commands that exist for troubleshooting PPP and other Layer 2 call operations. The table below lists some of these **debug** commands.

Table 20: Additional Debugging Commands for Troubleshooting the Subscriber Service Switch

Command	Purpose
debug ppp negotiation	Allows you to check that a client is passing PPP negotiation information.
debug pppoe errors	Displays PPPoE error messages.
debug pppoe events	Displays protocol event information.
debug vpdn call events	Enables VPDN call event debugging.
debug vpdn call fsm	Enables VPDN call setup state debugging.
debug vpdn elog	Enables VPDN performance event data collection.
debug vpdn events	Displays PPTP tunnel event change information.
debug vpdn l2x-data	Enables L2F and L2TP event and data debugging.
debug vpdn l2x-errors	Displays L2F and L2TP protocol errors that prevent tunnel establishment or normal operation.
debug vpdn l2x-events	Displays L2F and L2TP events that are part of tunnel establishment or shutdown.
debug vpdn l2x-packets	Enables L2F and L2TP packet level debugging.
debug vpdn errors	Displays PPTP protocol error messages.
debug vpdn message	Enables VPDN inter processing message debugging.
debug vpdn packet	Enables VPDN packet level debugging.
debug vpdn scalability	Enables VPDN scalability debugging.
debug vpdn sss errors	Displays diagnostic information about errors that may occur during VPDN Subscriber Service Switch call setup.
debug vpdn sss events	Displays diagnostic information about VPDN Subscriber Service Switch call setup events.

**Note**

The **debug** commands are intended only for troubleshooting purposes, because the volume of output generated by the software can result in severe performance degradation on the router.

How to Configure a Subscriber Service Switch Policy

The Subscriber Service Switch architecture is transparent, and existing PPP, VPDN, PPPoE, PPPoA, and authentication, authorization, and accounting (AAA) call configurations will continue to work in this environment. You can, however, enable Subscriber Service Switch preauthorization and Subscriber Service Switch type authorization. You may also find it helpful to verify Subscriber Service Switch call operation.

Enabling Domain Preauthorization on a NAS

Perform the following task to enable the NAS to perform domain authorization before tunneling.

SUMMARY STEPS

1. **enable**
2. **configure terminal**
3. `vpdn authorize domain`
4. **exit**
5. Router# `show running-config`

DETAILED STEPS

	Command or Action	Purpose
Step 1	enable Example: Router> <code>enable</code>	Enables privileged EXEC mode. <ul style="list-style-type: none"> • Enter your password if prompted.
Step 2	configure terminal Example: Router# <code>configure terminal</code>	Enters global configuration mode.
Step 3	<code>vpdn authorize domain</code> Example: Router(config)# <code>vpdn authorize domain</code>	Enables domain preauthorization on an Network Access Server (NAS).
Step 4	exit Example: Router(config)# <code>exit</code>	Exits global configuration mode.

	Command or Action	Purpose
Step 5	Router# show running-config Example: show running-config	Displays the configuration so you can check that you successfully enabled domain preauthorization.

What to Do Next

Create a RADIUS user profile for domain preauthorization. See the next section for more information.

Creating a RADIUS User Profile for Domain Preauthorization

The table below contains the attributes needed to enable domain preauthorization in a RADIUS user file. Refer to the Cisco IOS XE Security Configuration Guide for information about creating a RADIUS user profile.

Table 21: Attributes for the RADIUS User Profile for Domain Preauthorization

RADIUS Entry	Purpose
nas-port: <i>ip-address:slot/subslot/port/vpi.vci</i>	Configures the NAS port username for domain preauthorization. <ul style="list-style-type: none"> • <i>ip-address</i> : --Management IP address of the node switch processor (NSP). • <i>slot / subslot / port</i> --Specifies the ATM interface. • <i>vpi . vci</i> --Virtual path identifier (VPI) and virtual channel identifier (VCI) values for the PVC.
Password= "cisco"	Sets the fixed password.
User-Service-Type = Outbound-User	Configures the service type as outbound.
Cisco-AVpair= "vpdn:vpn-domain-list= domain1, domain2,..."	Specifies the domains accessible to the user. <ul style="list-style-type: none"> • <i>domain</i> --Domain to configure as accessible to the user.

Enabling a Subscriber Service Switch Preauthorization

When Subscriber Service Switch preauthorization is enabled on an LAC, local configurations for session limit per VC and per VLAN are overwritten by the per-NAS-port session limit downloaded from the server. Perform this task to enable preauthorization.

SUMMARY STEPS

1. enable
2. configure terminal
3. subscriber access {pppoe | pppoa} pre-authorize nas-port-id[aaa-method-list]
4. show sss session [all]
5. exit

DETAILED STEPS

	Command or Action	Purpose
Step 1	<p>enable</p> <p>Example:</p> <pre>Router> enable</pre>	<p>Enables privileged EXEC mode.</p> <ul style="list-style-type: none"> • Enter your password if prompted.
Step 2	<p>configure terminal</p> <p>Example:</p> <pre>Router# configure terminal</pre>	<p>Enters global configuration mode.</p>
Step 3	<p>subscriber access {pppoe pppoa} pre-authorize nas-port-id[aaa-method-list]</p> <p>Example:</p> <p>Example:</p> <pre>Router(config)# subscriber access pppoe pre-authorize nas-port-id mlist-llid</pre> <p>Example:</p>	<p>Enables Subscriber Service Switch preauthorization.</p> <p>Note The LACs maintain a current session number per NAS port. As a new session request comes in, the LAC makes a preauthorization request to AAA to get the session limit, and compares it with the number of sessions currently on that NAS port. This command ensures that session limit querying is only enabled for PPPoE-type calls, not for any other call types.</p>
Step 4	<p>show sss session [all]</p> <p>Example:</p> <pre>Router(config)# show sss session all</pre>	<p>Displays the Subscriber Service Switch session status.</p>
Step 5	<p>exit</p> <p>Example:</p> <pre>Router(config)# exit</pre>	<p>(Optional) Exits global configuration mode.</p>

What to Do Next

Information about troubleshooting a network running the Subscriber Service Switch can be found in the next section.

Troubleshooting the Subscriber Service Switch

Perform this task to troubleshoot the Subscriber Service Switch. Examples of normal and failure operations can be found in the [Troubleshooting the Subscriber Service Switch Examples](#), on page 180. Reports from **debug** commands should be sent to technical personnel at Cisco Systems for evaluation.

Perform the following task to troubleshoot a network running the Subscriber Service Switch.

SUMMARY STEPS

1. **enable**
2. **configure terminal**
3. **no logging console**
4. Use Telnet to access a router port and repeat Steps 2 and 3.
5. **terminal monitor**
6. **exit**
7. **debug sss *command-option***
8. **configure terminal**
9. **no terminal monitor**
10. **exit**

DETAILED STEPS

	Command or Action	Purpose
Step 1	enable Example: Router> enable	Enables privileged EXEC mode. <ul style="list-style-type: none"> • Enter your password if prompted.
Step 2	configure terminal Example: Router# configure terminal	Enters global configuration mode.
Step 3	no logging console Example: Router(config)# no logging console	Disables all logging to the console terminal. <ul style="list-style-type: none"> • To reenble logging to the console, use the logging console command.

	Command or Action	Purpose
Step 4	Use Telnet to access a router port and repeat Steps 2 and 3.	Enters global configuration mode in a recursive Telnet session, which allows the output to be redirected away from the console port.
Step 5	terminal monitor Example: Router(config)# terminal monitor	Enables logging output on the virtual terminal.
Step 6	exit Example: Router(config)# exit	Exits to privileged EXEC mode.
Step 7	debug sss <i>command-option</i> Example: Router# debug sss error	Enables the debug command. Note You can enter more than one debug command.
Step 8	configure terminal Example: Router# configure terminal	Enters global configuration mode.
Step 9	no terminal monitor Example: Router(config)# no terminal monitor	Disables logging on the virtual terminal.
Step 10	exit Example: Router(config)# exit	Exits to privileged EXEC mode.

Configuration Examples for Configuring a Subscriber Service Switch Policy

LAC Domain Authorization Example

The following example shows the configuration necessary for the LAC to participate in domain preauthorization:

```
!
aaa new-model
aaa authorization network default local group radius
!
vpdn authorize domain
!
radius-server host 10.9.9.9 auth-port 1645 acct-port 1646
radius-server attribute nas-port format d
radius-server key MyKey
radius-server vsa send authentication
!
```

Domain Preauthorization RADIUS User Profile Example

The following example shows a typical domain preauthorization RADIUS user profile:

```
user = nas-port:10.9.9.9:0/0/0/30.33
profile_id = 826
profile_cycle = 1
radius=Cisco {
check_items= {
2=cisco
}
reply_attributes= {
9,1="vpdn:vpn-domain-list=example1.com,example2.com"
6=5
}
}
}
```

Subscriber Service Switch Preauthorization Example

The following partial example signals the Subscriber Service Switch to preauthorize the NAS-Port-ID string before authorizing the domain name. This policy applies only to all sessions with a PPPoE access type.

```
vpdn-group 3
accept dialin
protocol pppoe
virtual-template 1
!
! Signals Subscriber Service Switch to preauthorize the NAS-Port-ID string before
! authorizing the domain name.
subscriber access pppoe pre-authorize nas-port-id mlist-llid
!
```

Verify Subscriber Service Switch Call Operation Example

The following example command output from the **show sss session all** command provides an extensive report of Subscriber Service Switch session activity. Each section shows the unique identifier for each session, which can be used to correlate that particular session with the session information retrieved from other **show** commands or **debug** command traces. See the following **show vpdn session** command output for an example of this unique ID correlation.

```
Router# show sss session all
Current SSS Information: Total sessions 9
SSS session handle is 40000013, state is connected, service is VPDN
Unique ID is 9
SIP subscriber access type(s) are PPPoE/PPP
Identifier is nobody3@example.com
Last Changed 00:02:49
Root SIP Handle is DF000010, PID is 49
AAA unique ID is 10
Current SIP options are Req Fwding/Req Fwde
SSS session handle is B0000017, state is connected, service is VPDN
Unique ID is 10
SIP subscriber access type(s) are PPPoE/PPP
Identifier is nobody3@example.com
Last Changed 00:02:05
Root SIP Handle is B9000015, PID is 49
AAA unique ID is 11
Current SIP options are Req Fwding/Req Fwde
SSS session handle is D6000019, state is connected, service is VPDN
Unique ID is 11
SIP subscriber access type(s) are PPPoE/PPP
Identifier is nobody3@example.com
Last Changed 00:02:13
Root SIP Handle is D0000016, PID is 49
AAA unique ID is 12
Current SIP options are Req Fwding/Req Fwde
SSS session handle is 8C000003, state is connected, service is VPDN
Unique ID is 3
SIP subscriber access type(s) are PPPoE/PPP
Identifier is user3@example.com
Last Changed 2d21h
Root SIP Handle is D3000002, PID is 49
AAA unique ID is 3
Current SIP options are Req Fwding/Req Fwde
SSS session handle is BE00000B, state is connected, service is Local Term
Unique ID is 6
SIP subscriber access type(s) are PPPoE/PPP
Identifier is user1
Last Changed 00:03:56
Root SIP Handle is A9000009, PID is 49
AAA unique ID is 7
Current SIP options are Req Fwding/Req Fwde
SSS session handle is DC00000D, state is connected, service is Local Term
Unique ID is 7
SIP subscriber access type(s) are PPPoE/PPP
Identifier is user2
Last Changed 00:03:57
Root SIP Handle is 2C00000A, PID is 49
AAA unique ID is 8
Current SIP options are Req Fwding/Req Fwde
SSS session handle is DB000011, state is connected, service is VPDN
Unique ID is 8
SIP subscriber access type(s) are PPPoE/PPP
Identifier is nobody3@example.com
Last Changed 00:02:58
Root SIP Handle is 1000000F, PID is 49
AAA unique ID is 9
Current SIP options are Req Fwding/Req Fwde
SSS session handle is 3F000007, state is connected, service is Local Term
```

```

Unique ID is 2
SIP subscriber access type(s) are PPP
Identifier is user1
Last Changed 00:05:30
Root SIP Handle is 8A000009, PID is 92
AAA unique ID is 1
Current SIP options are Req Fwding/Req Fwded
SSS session handle is 97000005, state is connected, service is VPDN
Unique ID is 4
SIP subscriber access type(s) are PPP
Identifier is nobody2@example.com
Last Changed 00:07:16
Root SIP Handle is 32000000, PID is 92
AAA unique ID is 5
Current SIP options are Req Fwding/Req Fwded

```

Correlating the Unique ID in show vpdn session Command Output

The following partial sample output from the **show vpdn session** command provides extensive reports on call activity for all L2TP, L2F, and PPPoE sessions, and identifies the unique ID for each session.

```

Router# show vpdn session all
L2TP Session Information Total tunnels 1 sessions 4
Session id 5 is up, tunnel id 13695
Call serial number is 3355500002
Remote tunnel name is User03
Internet address is 10.0.0.63
Session state is established, time since change 00:03:53
  52 Packets sent, 52 received
  2080 Bytes sent, 1316 received
Last clearing of "show vpdn" counters never
Session MTU is 1464 bytes
Session username is nobody3@example.com
Interface
  Remote session id is 692, remote tunnel id 58582
  UDP checksums are disabled
  SSS switching enabled
  No FS cached header information available
  Sequencing is off
Unique ID is 8
Session id 6 is up, tunnel id 13695
Call serial number is 3355500003
Remote tunnel name is User03
Internet address is 10.0.0.63
Session state is established, time since change 00:04:22
  52 Packets sent, 52 received
  2080 Bytes sent, 1316 received
Last clearing of "show vpdn" counters never
Session MTU is 1464 bytes
Session username is nobody3@example.com
Interface
  Remote session id is 693, remote tunnel id 58582
  UDP checksums are disabled
  SSS switching enabled
  No FS cached header information available
  Sequencing is off
Unique ID is 9

```

Troubleshooting the Subscriber Service Switch Examples

This section provides the following debugging session examples for a network running the Subscriber Service Switch:

Reports from **debug** commands should be sent to technical personnel at Cisco Systems for evaluation.

Troubleshooting the Subscriber Service Switch Operation Example

The following example shows the **debug** commands used and sample output for debugging Subscriber Service Switch operation:

```

Router# debug sss event
Router# debug sss error
Router# debug sss state
Router# debug sss aaa authorization event
Router# debug sss aaa authorization fsm
SSS:
  SSS events debugging is on
  SSS error debugging is on
  SSS fsm debugging is on
  SSS AAA authorization event debugging is on
  SSS AAA authorization FSM debugging is on
*Mar 4 21:33:18.248: SSS INFO: Element type is Access-Type, long value is 3
*Mar 4 21:33:18.248: SSS INFO: Element type is Switch-Id, long value is -1509949436
*Mar 4 21:33:18.248: SSS INFO: Element type is Nasport, ptr value is 6396882C
*Mar 4 21:33:18.248: SSS INFO: Element type is AAA-Id, long value is 7
*Mar 4 21:33:18.248: SSS INFO: Element type is AAA-ACCT_ENBL, long value is 1
*Mar 4 21:33:18.248: SSS INFO: Element type is AccIe-Hdl, ptr value is 78000006
*Mar 4 21:33:18.248: SSS MGR [uid:7]: Event service-request, state changed from
wait-for-req to wait-for-auth
*Mar 4 21:33:18.248: SSS MGR [uid:7]: Handling Policy Authorize (1 pending sessions)
*Mar 4 21:33:18.248: SSS PM [uid:7]: Need the following key: Unauth-User
*Mar 4 21:33:18.248: SSS PM [uid:7]: Received Service Request
*Mar 4 21:33:18.248: SSS PM [uid:7]: Event <need keys>, State: initial-req to
need-init-keys
*Mar 4 21:33:18.248: SSS PM [uid:7]: Policy reply - Need more keys
*Mar 4 21:33:18.248: SSS MGR [uid:7]: Got reply Need-More-Keys from PM
*Mar 4 21:33:18.248: SSS MGR [uid:7]: Event policy-or-mgr-more-keys, state changed from
wait-for-auth to wait-for-req
*Mar 4 21:33:18.248: SSS MGR [uid:7]: Handling More-Keys event
*Mar 4 21:33:20.256: SSS INFO: Element type is Unauth-User, string value is
nobody@example.com
*Mar 4 21:33:20.256: SSS INFO: Element type is AccIe-Hdl, ptr value is 78000006
*Mar 4 21:33:20.256: SSS INFO: Element type is AAA-Id, long value is 7
*Mar 4 21:33:20.256: SSS INFO: Element type is Access-Type, long value is 0
*Mar 4 21:33:20.256: SSS MGR [uid:7]: Event service-request, state changed from
wait-for-req to wait-for-auth
*Mar 4 21:33:20.256: SSS MGR [uid:7]: Handling Policy Authorize (1 pending sessions)
*Mar 4 21:33:20.256: SSS PM [uid:7]: Received More Initial Keys
*Mar 4 21:33:20.256: SSS PM [uid:7]: Event <rcvd keys>, State: need-init-keys to
check-auth-needed
*Mar 4 21:33:20.256: SSS PM [uid:7]: Handling Authorization Check
*Mar 4 21:33:20.256: SSS PM [uid:7]: Event <send auth>, State: check-auth-needed to
authorizing
*Mar 4 21:33:20.256: SSS PM [uid:7]: Handling AAA service Authorization
*Mar 4 21:33:20.256: SSS PM [uid:7]: Sending authorization request for 'example.com'
*Mar 4 21:33:20.256: SSS AAA AUTHOR [uid:7]:Event <make request>, state changed from idle
to authorizing
*Mar 4 21:33:20.256: SSS AAA AUTHOR [uid:7]:Authorizing key example.com
*Mar 4 21:33:20.260: SSS AAA AUTHOR [uid:7]:AAA request sent for key example.com
*Mar 4 21:33:20.260: SSS AAA AUTHOR [uid:7]:Received an AAA pass
*Mar 4 21:33:20.260: SSS AAA AUTHOR [uid:7]:Event <found service>, state changed from
authorizing to complete
*Mar 4 21:33:20.260: SSS AAA AUTHOR [uid:7]:Found service info for key example.com
*Mar 4 21:33:20.260: SSS AAA AUTHOR [uid:7]:Event <free request>, state changed from
complete to terminal
*Mar 4 21:33:20.260: SSS AAA AUTHOR [uid:7]:Free request
*Mar 4 21:33:20.264: SSS PM [uid:7]: Event <found>, State: authorizing to end
*Mar 4 21:33:20.264: SSS PM [uid:7]: Handling Service Direction
*Mar 4 21:33:20.264: SSS PM [uid:7]: Policy reply - Forwarding
*Mar 4 21:33:20.264: SSS MGR [uid:7]: Got reply Forwarding from PM
*Mar 4 21:33:20.264: SSS MGR [uid:7]: Event policy-start-service-fsp, state changed from
wait-for-auth to wait-for-service
*Mar 4 21:33:20.264: SSS MGR [uid:7]: Handling Connect-Forwarding-Service event

```

```
*Mar 4 21:33:20.272: SSS MGR [uid:7]: Event service-fsp-connected, state changed from
wait-for-service to connected
*Mar 4 21:33:20.272: SSS MGR [uid:7]: Handling Forwarding-Service-Connected event
```

Troubleshooting the Subscriber Service Switch on the LAC--Normal Operation Example

The following example shows the **debug** commands used and sample output indicating normal operation of the Subscriber Service Switch on the LAC:

```
Router# debug sss event
Router# debug sss error
Router# debug sss aaa authorization event
Router# debug sss aaa authorization fsm
Router# debug pppoe events
Router# debug pppoe errors
Router# debug ppp negotiation
Router# debug vpdn l2x-events
Router# debug vpdn l2x-errors
Router# debug vpdn sss events
Router# debug vpdn sss errors
Router# debug vpdn call events
Router# debug vpdn call fsm
Router# debug vpdn events
Router# debug vpdn errors
SSS:
  SSS events debugging is on
  SSS error debugging is on
  SSS AAA authorization event debugging is on
  SSS AAA authorization FSM debugging is on
PPPoE:
  PPPoE protocol events debugging is on
  PPPoE protocol errors debugging is on
PPP:
  PPP protocol negotiation debugging is on
VPN:
  L2X protocol events debugging is on
  L2X protocol errors debugging is on
  VPDN SSS events debugging is on
  VPDN SSS errors debugging is on
  VPDN call event debugging is on
  VPDN call FSM debugging is on
  VPDN events debugging is on
  VPDN errors debugging is on
*Nov 15 12:23:52.523: PPPoE 0: I PADI R:0000.0c14.71d0 L:ffff.ffff.ffff 1/32
ATM4/0.132
*Nov 15 12:23:52.523: PPPoE 0: O PADO R:0000.0c14.71d0 L:00b0.c2e9.c870 1/32
ATM4/0.132
*Nov 15 12:23:52.527: PPPoE 0: I PADR R:0000.0c14.71d0 L:00b0.c2e9.c870 1/32
ATM4/0.132
*Nov 15 12:23:52.527: PPPoE : encap string prepared
*Nov 15 12:23:52.527: [13]PPPoE 10: Access IE handle allocated
*Nov 15 12:23:52.527: [13]PPPoE 10: pppoe SSS switch updated
*Nov 15 12:23:52.527: [13]PPPoE 10: Service request sent to SSS
*Nov 15 12:23:52.527: [13]PPPoE 10: Created R:00b0.c2e9.c870 L:0000.0c14.71d0 1/32
ATM4/0.132
*Nov 15 12:23:52.547: SSS INFO: Element type is Access-Type, long value is 3
*Nov 15 12:23:52.547: SSS INFO: Element type is Switch-Id, long value is 2130706444
*Nov 15 12:23:52.547: SSS INFO: Element type is Nasport, ptr value is 63C07288
*Nov 15 12:23:52.547: SSS INFO: Element type is AAA-Id, long value is 14
*Nov 15 12:23:52.547: SSS INFO: Element type is AccIe-Hdl, ptr value is B20000C
*Nov 15 12:23:52.547: SSS MGR [uid:13]: Handling Policy Authorize (1 pending
sessions)
*Nov 15 12:23:52.547: SSS PM [uid:13]: RM/VPDN disabled: RM/VPDN author not needed
*Nov 15 12:23:52.547: SSS PM [uid:13]: Received Service Request
*Nov 15 12:23:52.547: SSS PM [uid:13]: Handling Authorization Check
*Nov 15 12:23:52.547: SSS PM [uid:13]: Policy requires 'Unauth-User' key
*Nov 15 12:23:52.547: SSS PM [uid:13]: Policy reply - Need more keys
*Nov 15 12:23:52.547: SSS MGR [uid:13]: Got reply Need-More-Keys from PM
*Nov 15 12:23:52.547: SSS MGR [uid:13]: Handling More-Keys event
```

```

*Nov 15 12:23:52.547: [13]PPPoE 10: State REQ_NASPORT      Event MORE_KEYS
*Nov 15 12:23:52.547: [13]PPPoE 10: O PADS R:0000.0c14.71d0 L:00b0.c2e9.c870 1/32
ATM4/0.132
*Nov 15 12:23:52.547: ppp13 PPP: Using default call direction
*Nov 15 12:23:52.547: ppp13 PPP: Treating connection as a dedicated line
*Nov 15 12:23:52.547: ppp13 PPP: Phase is ESTABLISHING, Active Open
*Nov 15 12:23:52.547: ppp13 LCP: O CONFREQ [Closed] id 1 len 19
*Nov 15 12:23:52.547: ppp13 LCP:      MRU 1492 (0x010405D4)
*Nov 15 12:23:52.547: ppp13 LCP:      AuthProto CHAP (0x0305C22305)
*Nov 15 12:23:52.547: ppp13 LCP:      MagicNumber 0xB0EC4557 (0x0506B0EC4557)
*Nov 15 12:23:52.547: [13]PPPoE 10: State START_PPP      Event DYN_BIND
*Nov 15 12:23:52.547: [13]PPPoE 10: data path set to PPP
*Nov 15 12:23:52.571: ppp13 LCP: I CONFREQ [REQsent] id 1 len 14
*Nov 15 12:23:52.571: ppp13 LCP:      MRU 1492 (0x010405D4)
*Nov 15 12:23:52.571: ppp13 LCP:      MagicNumber 0x0017455D (0x05060017455D)
*Nov 15 12:23:52.571: ppp13 LCP: O CONFACK [REQsent] id 1 len 14
*Nov 15 12:23:52.571: ppp13 LCP:      MRU 1492 (0x010405D4)
*Nov 15 12:23:52.571: ppp13 LCP:      MagicNumber 0x0017455D (0x05060017455D)
*Nov 15 12:23:54.543: ppp13 LCP: TIMEOUT: State ACKsent
*Nov 15 12:23:54.543: ppp13 LCP: O CONFREQ [ACKsent] id 2 len 19
*Nov 15 12:23:54.543: ppp13 LCP:      MRU 1492 (0x010405D4)
*Nov 15 12:23:54.543: ppp13 LCP:      AuthProto CHAP (0x0305C22305)
*Nov 15 12:23:54.543: ppp13 LCP:      MagicNumber 0xB0EC4557 (0x0506B0EC4557)
*Nov 15 12:23:54.543: ppp13 LCP: I CONFACK [ACKsent] id 2 len 19
*Nov 15 12:23:54.543: ppp13 LCP:      MRU 1492 (0x010405D4)
*Nov 15 12:23:54.543: ppp13 LCP:      AuthProto CHAP (0x0305C22305)
*Nov 15 12:23:54.543: ppp13 LCP:      MagicNumber 0xB0EC4557 (0x0506B0EC4557)
*Nov 15 12:23:54.543: ppp13 LCP: State is Open
*Nov 15 12:23:54.543: ppp13 PPP: Phase is AUTHENTICATING, by this end
*Nov 15 12:23:54.543: ppp13 CHAP: O CHALLENGE id 1 len 25 from "7200"
*Nov 15 12:23:54.547: ppp13 CHAP: I RESPONSE id 1 len 38 from "nobody@example.com"
*Nov 15 12:23:54.547: ppp13 PPP: Phase is FORWARDING, Attempting Forward
*Nov 15 12:23:54.547: SSS INFO: Element type is Unauth-User, string value is
nobody@example.com
*Nov 15 12:23:54.547: SSS INFO: Element type is AccIe-Hdl, ptr value is B200000C
*Nov 15 12:23:54.547: SSS INFO: Element type is AAA-Id, long value is 14
*Nov 15 12:23:54.547: SSS INFO: Element type is Access-Type, long value is 0
*Nov 15 12:23:54.547: SSS MGR [uid:13]: Handling Policy Authorize (1 pending
sessions)
*Nov 15 12:23:54.547: SSS PM [uid:13]: Received More Keys
*Nov 15 12:23:54.547: SSS PM [uid:13]: Handling Authorization Check
*Nov 15 12:23:54.547: SSS PM [uid:13]: Handling AAA service Authorization
*Nov 15 12:23:54.547: SSS PM [uid:13]: Sending authorization request for 'example.com'
*Nov 15 12:23:54.547: SSS AAA AUTHOR [uid:13]:Event <make request>, state changed
from idle to authorizing
*Nov 15 12:23:54.547: SSS AAA AUTHOR [uid:13]:Authorizing key example.com
*Nov 15 12:23:54.547: SSS AAA AUTHOR [uid:13]:AAA request sent for key example.com
*Nov 15 12:23:54.551: SSS AAA AUTHOR [uid:13]:Received an AAA pass
*Nov 15 12:23:54.551: SSS AAA AUTHOR [uid:13]:Event <found service>, state changed
from authorizing to complete
*Nov 15 12:23:54.551: SSS AAA AUTHOR [uid:13]:Found service info for key example.com
*Nov 15 12:23:54.551: SSS AAA AUTHOR [uid:13]:Event <free request>, state changed
from complete to terminal
*Nov 15 12:23:54.551: SSS AAA AUTHOR [uid:13]:Free request
*Nov 15 12:23:54.551: SSS PM [uid:13]: Handling Service Direction
*Nov 15 12:23:54.551: SSS PM [uid:13]: Policy reply - Forwarding
*Nov 15 12:23:54.551: SSS MGR [uid:13]: Got reply Forwarding from PM
*Nov 15 12:23:54.551: SSS MGR [uid:13]: Handling Connect-Service event
*Nov 15 12:23:54.551: VPDN CALL [uid:13]: Event connect req, state changed from idle
to connecting
*Nov 15 12:23:54.551: VPDN CALL [uid:13]: Requesting connection
*Nov 15 12:23:54.551: VPDN CALL [uid:13]: Call request sent
*Nov 15 12:23:54.551: VPDN MGR [uid:13]: Event client connect, state changed from
idle to connecting
*Nov 15 12:23:54.551: VPDN MGR [uid:13]: Initiating compulsory connection to
192.168.8.2
*Nov 15 12:23:54.551: Tnl/Sn61510/7 L2TP: Session FS enabled
*Nov 15 12:23:54.551: Tnl/Sn61510/7 L2TP: Session state change from idle to
wait-for-tunnel
*Nov 15 12:23:54.551: uid:13 Tnl/Sn61510/7 L2TP: Create session
*Nov 15 12:23:54.551: uid:13 Tnl/Sn61510/7 L2TP: O ICRQ to rpl 9264/0
*Nov 15 12:23:54.551: [13]PPPoE 10: Access IE nas port called
*Nov 15 12:23:54.555: Tnl61510 L2TP: Control channel retransmit delay set to 1

```

```

seconds
*Nov 15 12:23:54.555: uid:13 Tnl/Sn61510/7 L2TP: Session state change from
wait-for-tunnel to wait-reply
*Nov 15 12:23:54.555: [13]PPPoE 10: State LCP_NEGO Event PPP_FWDING
*Nov 15 12:23:54.559: uid:13 Tnl/Sn61510/7 L2TP: O ICCN to rp1 9264/13586
*Nov 15 12:23:54.559: Tnl61510 L2TP: Control channel retransmit delay set to 1
seconds
*Nov 15 12:23:54.559: uid:13 Tnl/Sn61510/7 L2TP: Session state change from
wait-reply to established
*Nov 15 12:23:54.559: uid:13 Tnl/Sn61510/7 L2TP: VPDN session up
*Nov 15 12:23:54.559: VPDN MGR [uid:13]: Event peer connected, state changed from
connecting to connected
*Nov 15 12:23:54.559: VPDN MGR [uid:13]: Succeed to forward nobody@example.com
*Nov 15 12:23:54.559: VPDN MGR [uid:13]: accounting start sent
*Nov 15 12:23:54.559: VPDN CALL [uid:13]: Event connect ok, state changed from
connecting to connected
*Nov 15 12:23:54.559: VPDN CALL [uid:13]: Connection succeeded
*Nov 15 12:23:54.559: SSS MGR [uid:13]: Handling Service-Connected event
*Nov 15 12:23:54.559: ppp13 PPP: Phase is FORWARDED, Session Forwarded
*Nov 15 12:23:54.559: [13]PPPoE 10: State LCP_NEGO Event PPP_FWDING
*Nov 15 12:23:54.563: [13]PPPoE 10: data path_set to SSS Switch
*Nov 15 12:23:54.563: [13]PPPoE 10: Connected Forwarded

```

Troubleshooting the Subscriber Service Switch on the LAC--Authorization Failure Example

The following is sample output indicating call failure due to authorization failure:

```

*Nov 15 12:37:24.535: PPPoE 0: I PADI R:0000.0c14.71d0 L:ffff.ffff.ffff 1/32
ATM4/0.132
*Nov 15 12:37:24.535: PPPoE 0: O PADO R:0000.0c14.71d0 L:00b0.c2e9.c870 1/32
ATM4/0.132
*Nov 15 12:37:24.539: PPPoE 0: I PADR R:0000.0c14.71d0 L:00b0.c2e9.c870 1/32
ATM4/0.132
*Nov 15 12:37:24.539: PPPoE : encaps string prepared
*Nov 15 12:37:24.539: [18]PPPoE 15: Access IE handle allocated
*Nov 15 12:37:24.539: [18]PPPoE 15: pppoe SSS switch updated
*Nov 15 12:37:24.539: PPPoE 15: AAA pppoe_aaa_acct_get_retrieved_attrs
*Nov 15 12:37:24.539: [18]PPPoE 15: AAA pppoe_aaa_acct_get_nas_port_details
*Nov 15 12:37:24.539: [18]PPPoE 15: AAA pppoe_aaa_acct_get_dynamic_attrs
*Nov 15 12:37:24.539: [18]PPPoE 15: AAA pppoe_aaa_acct_get_dynamic_attrs
*Nov 15 12:37:24.539: [18]PPPoE 15: AAA unique ID allocated
*Nov 15 12:37:24.539: [18]PPPoE 15: No AAA accounting method list
*Nov 15 12:37:24.539: [18]PPPoE 15: Service request sent to SSS
*Nov 15 12:37:24.539: [18]PPPoE 15: Created R:00b0.c2e9.c870 L:0000.0c14.71d0 1/32
ATM4/0.132
*Nov 15 12:37:24.559: SSS INFO: Element type is Access-Type, long value is 3
*Nov 15 12:37:24.559: SSS INFO: Element type is Switch-Id, long value is -738197487
*Nov 15 12:37:24.559: SSS INFO: Element type is Nasport, ptr value is 63C0E590
*Nov 15 12:37:24.559: SSS INFO: Element type is AAA-Id, long value is 19
*Nov 15 12:37:24.559: SSS INFO: Element type is AccIe-Hdl, ptr value is 5B000011
*Nov 15 12:37:24.559: SSS MGR [uid:18]: Handling Policy Authorize (1 pending
sessions)
*Nov 15 12:37:24.559: SSS PM [uid:18]: RM/VPDN disabled: RM/VPDN author not needed
*Nov 15 12:37:24.559: SSS PM [uid:18]: Received Service Request
*Nov 15 12:37:24.559: SSS PM [uid:18]: Handling Authorization Check
*Nov 15 12:37:24.559: SSS PM [uid:18]: Policy requires 'Unauth-User' key
*Nov 15 12:37:24.559: SSS PM [uid:18]: Policy reply - Need more keys
*Nov 15 12:37:24.559: SSS MGR [uid:18]: Got reply Need-More-Keys from PM
*Nov 15 12:37:24.559: SSS MGR [uid:18]: Handling More-Keys event
*Nov 15 12:37:24.559: [18]PPPoE 15: State REQ_NASPORT Event MORE_KEYS
*Nov 15 12:37:24.559: [18]PPPoE 15: O PADS R:0000.0c14.71d0 L:00b0.c2e9.c870 1/32
ATM4/0.132
*Nov 15 12:37:24.559: ppp18 PPP: Using default call direction
*Nov 15 12:37:24.559: ppp18 PPP: Treating connection as a dedicated line
*Nov 15 12:37:24.559: ppp18 PPP: Phase is ESTABLISHING, Active Open
*Nov 15 12:37:24.559: ppp18 LCP: O CONFREQ [Closed] id 1 len 19
*Nov 15 12:37:24.559: ppp18 LCP: MRU 1492 (0x010405D4)
*Nov 15 12:37:24.559: ppp18 LCP: AuthProto CHAP (0x0305C22305)
*Nov 15 12:37:24.559: ppp18 LCP: MagicNumber 0xB0F8A971 (0x0506B0F8A971)
*Nov 15 12:37:24.559: [18]PPPoE 15: State START_PPP Event DYN_BIND

```



```

*Nov 15 12:37:24.559: [18]PPPoE 15: data path set to PPP
*Nov 15 12:37:24.563: ppp18 LCP: I CONFREQ [REQsent] id 1 len 14
*Nov 15 12:37:24.563: ppp18 LCP: MRU 1492 (0x010405D4)
*Nov 15 12:37:24.563: ppp18 LCP: MagicNumber 0x0023A93E (0x05060023A93E)
*Nov 15 12:37:24.563: ppp18 LCP: O CONFACK [REQsent] id 1 len 14
*Nov 15 12:37:24.563: ppp18 LCP: MRU 1492 (0x010405D4)
*Nov 15 12:37:24.563: ppp18 LCP: MagicNumber 0x0023A93E (0x05060023A93E)
*Nov 15 12:37:26.523: ppp18 LCP: I CONFREQ [ACKsent] id 2 len 14
*Nov 15 12:37:26.523: ppp18 LCP: MRU 1492 (0x010405D4)
*Nov 15 12:37:26.523: ppp18 LCP: MagicNumber 0x0023A93E (0x05060023A93E)
*Nov 15 12:37:26.523: ppp18 LCP: O CONFACK [ACKsent] id 2 len 14
*Nov 15 12:37:26.527: ppp18 LCP: MRU 1492 (0x010405D4)
*Nov 15 12:37:26.527: ppp18 LCP: MagicNumber 0x0023A93E (0x05060023A93E)
*Nov 15 12:37:26.575: ppp18 LCP: TIMEout: State ACKsent
*Nov 15 12:37:26.575: ppp18 LCP: O CONFREQ [ACKsent] id 2 len 19
*Nov 15 12:37:26.575: ppp18 LCP: MRU 1492 (0x010405D4)
*Nov 15 12:37:26.575: ppp18 LCP: AuthProto CHAP (0x0305C22305)
*Nov 15 12:37:26.575: ppp18 LCP: MagicNumber 0xB0F8A971 (0x0506B0F8A971)
*Nov 15 12:37:26.575: ppp18 LCP: I CONFACK [ACKsent] id 2 len 19
*Nov 15 12:37:26.575: ppp18 LCP: MRU 1492 (0x010405D4)
*Nov 15 12:37:26.575: ppp18 LCP: AuthProto CHAP (0x0305C22305)
*Nov 15 12:37:26.575: ppp18 LCP: MagicNumber 0xB0F8A971 (0x0506B0F8A971)
*Nov 15 12:37:26.575: ppp18 LCP: State is Open
*Nov 15 12:37:26.575: ppp18 PPP: Phase is AUTHENTICATING, by this end
*Nov 15 12:37:26.575: ppp18 CHAP: O CHALLENGE id 1 len 25 from "7200"
*Nov 15 12:37:26.579: ppp18 CHAP: I RESPONSE id 1 len 38 from "nobody@example.com"
Nov 15 12:37:26.579: ppp18 PPP: Phase is FORWARDING, Attempting Forward
*Nov 15 12:37:26.579: SSS INFO: Element type is Unauth-User, string value is
nobody@example.com
*Nov 15 12:37:26.579: SSS INFO: Element type is AccIe-Hdl, ptr value is 5B000011
*Nov 15 12:37:26.579: SSS INFO: Element type is AAA-Id, long value is 19
Nov 15 12:37:26.579: SSS INFO: Element type is Access-Type, long value is 0
*Nov 15 12:37:26.579: SSS MGR [uid:18]: Handling Policy Authorize (1 pending
sessions)
*Nov 15 12:37:26.579: SSS PM [uid:18]: Received More Keys
*Nov 15 12:37:26.579: SSS PM [uid:18]: Handling Authorization Check
*Nov 15 12:37:26.579: SSS PM [uid:18]: Handling AAA service Authorization
*Nov 15 12:37:26.579: SSS PM [uid:18]: Sending authorization request for 'example.com'
*Nov 15 12:37:26.579: SSS AAA AUTHOR [uid:18]:Event <make request>, state changed
from idle to authorizing
*Nov 15 12:37:26.579: SSS AAA AUTHOR [uid:18]:Authorizing key example.com
*Nov 15 12:37:26.579: SSS AAA AUTHOR [uid:18]:AAA request sent for key example.com
*Nov 15 12:37:26.587: SSS AAA AUTHOR [uid:18]:Received an AAA failure
*Nov 15 12:37:26.587: SSS AAA AUTHOR [uid:18]:Event <service not found>, state
changed from authorizing to complete
*Nov 15 12:37:26.587: SSS AAA AUTHOR [uid:18]:No service authorization info found
*Nov 15 12:37:26.587: SSS AAA AUTHOR [uid:18]:Event <free request>, state changed
from complete to terminal
*Nov 15 12:37:26.587: SSS AAA AUTHOR [uid:18]:Free request
*Nov 15 12:37:26.587: SSS PM [uid:18]: Handling Next Authorization Check
*Nov 15 12:37:26.587: SSS PM [uid:18]: Default policy: SGF author not needed
*Nov 15 12:37:26.587: SSS PM [uid:18]: Handling Default Service
*Nov 15 12:37:26.587: SSS PM [uid:18]: Policy reply - Local terminate
*Nov 15 12:37:26.591: SSS MGR [uid:18]: Got reply Local-Term from PM
*Nov 15 12:37:26.591: SSS MGR [uid:18]: Handling Send-Client-Local-Term event
*Nov 15 12:37:26.591: ppp18 PPP: Phase is AUTHENTICATING, Unauthenticated User
Nov 15 12:37:26.595: ppp18 CHAP: O FAILURE id 1 len 25 msg is "Authentication
failed"
*Nov 15 12:37:26.599: ppp18 PPP: Sending Acct Event[Down] id[13]
*Nov 15 12:37:26.599: ppp18 PPP: Phase is TERMINATING
*Nov 15 12:37:26.599: ppp18 LCP: O TERMREQ [Open] id 3 len 4
*Nov 15 12:37:26.599: ppp18 LCP: State is Closed
*Nov 15 12:37:26.599: ppp18 PPP: Phase is DOWN
*Nov 15 12:37:26.599: ppp18 PPP: Phase is TERMINATING
*Nov 15 12:37:26.599: [18]PPPoE 15: State LCP_NEGO Event PPP_DISCNCT
*Nov 15 12:37:26.599: [18]PPPoE 15: O PADT R:0000.0c14.71d0 L:00b0.c2e9.c870 1/32
ATM4/0.132
*Nov 15 12:37:26.599: [18]PPPoE 15: Destroying R:0000.0c14.71d0 L:00b0.c2e9.c870
1/32 ATM4/0.132
*Nov 15 12:37:26.599: [18]PPPoE 15: AAA account stopped
*Nov 15 12:37:26.599: SSS MGR [uid:18]: Processing a client disconnect
*Nov 15 12:37:26.599: SSS MGR [uid:18]: Handling Send-Service-Disconnect event

```

Troubleshooting the Subscriber Service Switch on the LAC--Authentication Failure Example

The following is sample output indicating call failure due to authentication failure at the LNS:

```
*Nov 15 12:45:02.067: PPPoE 0: I PADI R:0000.0c14.71d0 L:ffff.ffff.ffff 1/32
ATM4/0.132
*Nov 15 12:45:02.071: PPPoE 0: O PADO R:0000.0c14.71d0 L:00b0.c2e9.c870 1/32
ATM4/0.132
*Nov 15 12:45:02.071: PPPoE 0: I PADR R:0000.0c14.71d0 L:00b0.c2e9.c870 1/32
ATM4/0.132
*Nov 15 12:45:02.071: PPPoE : encaps string prepared
*Nov 15 12:45:02.071: [21]PPPoE 18: Access IE handle allocated
*Nov 15 12:45:02.071: [21]PPPoE 18: pppoe SSS switch updated
*Nov 15 12:45:02.071: PPPoE 18: AAA pppoe_aaa_acct_get_retrieved_attrs
*Nov 15 12:45:02.071: [21]PPPoE 18: AAA pppoe_aaa_acct_get_nas_port_details
*Nov 15 12:45:02.071: [21]PPPoE 18: AAA pppoe_aaa_acct_get_dynamic_attrs
*Nov 15 12:45:02.071: [21]PPPoE 18: AAA pppoe_aaa_acct_get_dynamic_attrs
*Nov 15 12:45:02.071: [21]PPPoE 18: AAA unique ID allocated
*Nov 15 12:45:02.071: [21]PPPoE 18: No AAA accounting method list
*Nov 15 12:45:02.071: [21]PPPoE 18: Service request sent to SSS
*Nov 15 12:45:02.071: [21]PPPoE 18: Created R:00b0.c2e9.c870 L:0000.0c14.71d0 1/32
ATM4/0.132
*Nov 15 12:45:02.091: SSS INFO: Element type is Access-Type, long value is 3
*Nov 15 12:45:02.091: SSS INFO: Element type is Switch-Id, long value is 1946157076
*Nov 15 12:45:02.091: SSS INFO: Element type is Nasport, ptr value is 63B34170
*Nov 15 12:45:02.091: SSS INFO: Element type is AAA-Id, long value is 22
*Nov 15 12:45:02.091: SSS INFO: Element type is AccIe-Hdl, ptr value is 71000014
*Nov 15 12:45:02.091: SSS MGR [uid:21]: Handling Policy Authorize (1 pending
sessions)
*Nov 15 12:45:02.091: SSS PM [uid:21]: RM/VPDN disabled: RM/VPDN author not needed
*Nov 15 12:45:02.091: SSS PM [uid:21]: Received Service Request
*Nov 15 12:45:02.091: SSS PM [uid:21]: Handling Authorization Check
*Nov 15 12:45:02.091: SSS PM [uid:21]: Policy requires 'Unauth-User' key
*Nov 15 12:45:02.091: SSS PM [uid:21]: Policy reply - Need more keys
*Nov 15 12:45:02.091: SSS MGR [uid:21]: Got reply Need-More-Keys from PM
*Nov 15 12:45:02.091: SSS MGR [uid:21]: Handling More-Keys event
*Nov 15 12:45:02.091: [21]PPPoE 18: State REQ_NASPORT Event MORE_KEYS
*Nov 15 12:45:02.091: [21]PPPoE 18: O PADS R:0000.0c14.71d0 L:00b0.c2e9.c870 1/32
ATM4/0.132
*Nov 15 12:45:02.091: ppp21 PPP: Using default call direction
*Nov 15 12:45:02.091: ppp21 PPP: Treating connection as a dedicated line
*Nov 15 12:45:02.091: ppp21 PPP: Phase is ESTABLISHING, Active Open
*Nov 15 12:45:02.091: ppp21 LCP: O CONFREQ [Closed] id 1 len 19
*Nov 15 12:45:02.091: ppp21 LCP: MRU 1492 (0x010405D4)
*Nov 15 12:45:02.091: ppp21 LCP: AuthProto CHAP (0x0305C22305)
*Nov 15 12:45:02.091: ppp21 LCP: MagicNumber 0xB0FFFA4D8 (0x0506B0FFFA4D8)
*Nov 15 12:45:02.091: [21]PPPoE 18: State START_PPP Event DYN_BIND
*Nov 15 12:45:02.091: [21]PPPoE 18: data path set to PPP
*Nov 15 12:45:02.095: ppp21 LCP: I CONFREQ [REQsent] id 1 len 14
*Nov 15 12:45:02.095: ppp21 LCP: MRU 1492 (0x010405D4)
*Nov 15 12:45:02.095: ppp21 LCP: MagicNumber 0x002AA481 (0x0506002AA481)
*Nov 15 12:45:02.095: ppp21 LCP: O CONFACK [REQsent] id 1 len 14
*Nov 15 12:45:02.095: ppp21 LCP: MRU 1492 (0x010405D4)
*Nov 15 12:45:02.095: ppp21 LCP: MagicNumber 0x002AA481 (0x0506002AA481)
*Nov 15 12:45:02.315: Tnl41436 L2TP: I StopCCN from rp1 tnl 31166
*Nov 15 12:45:02.315: Tnl41436 L2TP: Shutdown tunnel
*Nov 15 12:45:02.315: Tnl41436 L2TP: Tunnel state change from no-sessions-left to
idle
*Nov 15 12:45:04.055: ppp21 LCP: I CONFREQ [ACKsent] id 2 len 14
*Nov 15 12:45:04.055: ppp21 LCP: MRU 1492 (0x010405D4)
*Nov 15 12:45:04.059: ppp21 LCP: MagicNumber 0x002AA481 (0x0506002AA481)
*Nov 15 12:45:04.059: ppp21 LCP: O CONFACK [ACKsent] id 2 len 14
*Nov 15 12:45:04.059: ppp21 LCP: MRU 1492 (0x010405D4)
*Nov 15 12:45:04.059: ppp21 LCP: MagicNumber 0x002AA481 (0x0506002AA481)
*Nov 15 12:45:04.079: ppp21 LCP: TIMEOUT: State ACKsent
*Nov 15 12:45:04.079: ppp21 LCP: O CONFREQ [ACKsent] id 2 len 19
*Nov 15 12:45:04.079: ppp21 LCP: MRU 1492 (0x010405D4)
*Nov 15 12:45:04.079: ppp21 LCP: AuthProto CHAP (0x0305C22305)
*Nov 15 12:45:04.079: ppp21 LCP: MagicNumber 0xB0FFFA4D8 (0x0506B0FFFA4D8)
*Nov 15 12:45:04.079: ppp21 LCP: I CONFACK [ACKsent] id 2 len 19
```

```

*Nov 15 12:45:04.079: ppp21 LCP: MRU 1492 (0x010405D4)
*Nov 15 12:45:04.079: ppp21 LCP: AuthProto CHAP (0x0305C22305)
*Nov 15 12:45:04.079: ppp21 LCP: MagicNumber 0xB0FFA4D8 (0x0506B0FFA4D8)
*Nov 15 12:45:04.079: ppp21 LCP: State is Open
*Nov 15 12:45:04.079: ppp21 PPP: Phase is AUTHENTICATING, by this end
*Nov 15 12:45:04.079: ppp21 CHAP: O CHALLENGE id 1 len 25 from "7200"
*Nov 15 12:45:04.083: ppp21 CHAP: I RESPONSE id 1 len 38 from "nobody@example.com"
*Nov 15 12:45:04.083: ppp21 PPP: Phase is FORWARDING, Attempting Forward
*Nov 15 12:45:04.083: SSS INFO: Element type is Unauth-User, string value is
nobody@example.com
*Nov 15 12:45:04.083: SSS INFO: Element type is AccIe-Hdl, ptr value is 71000014
*Nov 15 12:45:04.083: SSS INFO: Element type is AAA-Id, long value is 22
*Nov 15 12:45:04.083: SSS INFO: Element type is Access-Type, long value is 0
*Nov 15 12:45:04.083: SSS MGR [uid:21]: Handling Policy Authorize (1 pending
sessions)
*Nov 15 12:45:04.083: SSS PM [uid:21]: Received More Keys
*Nov 15 12:45:04.083: SSS PM [uid:21]: Handling Authorization Check
*Nov 15 12:45:04.083: SSS PM [uid:21]: Handling AAA service Authorization
*Nov 15 12:45:04.083: SSS PM [uid:21]: Sending authorization request for 'example.com'
*Nov 15 12:45:04.083: SSS AAA AUTHOR [uid:21]:Event <make request>, state changed
from idle to authorizing
*Nov 15 12:45:04.083: SSS AAA AUTHOR [uid:21]:Authorizing key example.com
*Nov 15 12:45:04.083: SSS AAA AUTHOR [uid:21]:AAA request sent for key example.com
*Nov 15 12:45:04.095: SSS AAA AUTHOR [uid:21]:Received an AAA pass
*Nov 15 12:45:04.095: SSS AAA AUTHOR [uid:21]:Event <found service>, state changed
from authorizing to complete
*Nov 15 12:45:04.095: SSS AAA AUTHOR [uid:21]:Found service info for key example.com
*Nov 15 12:45:04.095: SSS AAA AUTHOR [uid:21]:Event <free request>, state changed
from complete to terminal
*Nov 15 12:45:04.095: SSS AAA AUTHOR [uid:21]:Free request
*Nov 15 12:45:04.095: SSS PM [uid:21]: Handling Service Direction
*Nov 15 12:45:04.095: SSS PM [uid:21]: Policy reply - Forwarding
*Nov 15 12:45:04.095: SSS MGR [uid:21]: Got reply Forwarding from PM
*Nov 15 12:45:04.099: SSS MGR [uid:21]: Handling Connect-Service event
*Nov 15 12:45:04.099: VPDN CALL [uid:21]: Event connect req, state changed from idle
to connecting
*Nov 15 12:45:04.099: VPDN CALL [uid:21]: Requesting connection
*Nov 15 12:45:04.099: VPDN CALL [uid:21]: Call request sent
*Nov 15 12:45:04.099: VPDN MGR [uid:21]: Event client connect, state changed from
idle to connecting
*Nov 15 12:45:04.099: VPDN MGR [uid:21]: Initiating compulsory connection to
192.168.8.2
*Nov 15 12:45:04.099: Tnl/Sn31399/10 L2TP: Session FS enabled
*Nov 15 12:45:04.099: Tnl/Sn31399/10 L2TP: Session state change from idle to
wait-for-tunnel
*Nov 15 12:45:04.099: uid:21 Tnl/Sn31399/10 L2TP: Create session
*Nov 15 12:45:04.099: Tnl31399 L2TP: SM State idle
*Nov 15 12:45:04.099: Tnl31399 L2TP: O SCCRQ
*Nov 15 12:45:04.099: Tnl31399 L2TP: Control channel retransmit delay set to 1
seconds
*Nov 15 12:45:04.099: Tnl31399 L2TP: Tunnel state change from idle to
wait-ctl-reply
*Nov 15 12:45:04.099: Tnl31399 L2TP: SM State wait-ctl-reply
*Nov 15 12:45:04.099: [21]PPPoE 18: State LCP_NEGO Event PPP_FWDING
*Nov 15 12:45:04.107: Tnl31399 L2TP: I SCCRP from rp1
*Nov 15 12:45:04.107: Tnl31399 L2TP: Got a challenge from remote peer, rp1
*Nov 15 12:45:04.107: Tnl31399 L2TP: Got a response from remote peer, rp1
*Nov 15 12:45:04.107: Tnl31399 L2TP: Tunnel Authentication success
*Nov 15 12:45:04.107: Tnl31399 L2TP: Tunnel state change from wait-ctl-reply to
established
*Nov 15 12:45:04.107: Tnl31399 L2TP: O SCCCN to rp1 tnlid 9349
*Nov 15 12:45:04.107: Tnl31399 L2TP: Control channel retransmit delay set to 1
seconds
*Nov 15 12:45:04.107: Tnl31399 L2TP: SM State established
*Nov 15 12:45:04.107: uid:21 Tnl/Sn31399/10 L2TP: O ICRQ to rp1 9349/0
*Nov 15 12:45:04.107: [21]PPPoE 18: Access IE nas port called
*Nov 15 12:45:04.107: uid:21 Tnl/Sn31399/10 L2TP: Session state change from
wait-for-tunnel to wait-reply
*Nov 15 12:45:04.115: uid:21 Tnl/Sn31399/10 L2TP: O ICCN to rp1 9349/13589
*Nov 15 12:45:04.115: Tnl31399 L2TP: Control channel retransmit delay set to 1
seconds
*Nov 15 12:45:04.115: uid:21 Tnl/Sn31399/10 L2TP: Session state change from
wait-reply to established

```

```

*Nov 15 12:45:04.115: uid:21 Tnl/Sn31399/10 L2TP: VPDN session up
*Nov 15 12:45:04.115: VPDN MGR [uid:21]: Event peer connected, state changed from
connecting to connected
*Nov 15 12:45:04.115: VPDN MGR [uid:21]: Succeed to forward nobody@example.com
*Nov 15 12:45:04.115: VPDN MGR [uid:21]: accounting start sent
*Nov 15 12:45:04.115: [21]PPPoE 18: AAA pppoe_aaa_acct_get_dynamic_attrs
*Nov 15 12:45:04.115: [21]PPPoE 18: AAA pppoe_aaa_acct_get_dynamic_attrs
*Nov 15 12:45:04.115: VPDN CALL [uid:21]: Event connect ok, state changed from
connecting to connected
*Nov 15 12:45:04.115: VPDN CALL [uid:21]: Connection succeeded
*Nov 15 12:45:04.115: SSS MGR [uid:21]: Handling Service-Connected event
*Nov 15 12:45:04.115: ppp21 PPP: Phase is FORWARDED, Session Forwarded
*Nov 15 12:45:04.115: [21]PPPoE 18: State LCP_NEGO Event PPP_FWDED
*Nov 15 12:45:04.115: [21]PPPoE 18: data path set to SSS Switch
*Nov 15 12:45:04.119: [21]PPPoE 18: Connected Forwarded
*Nov 15 12:45:04.119: ppp21 PPP: Process pending packets
*Nov 15 12:45:04.139: uid:21 Tnl/Sn31399/10 L2TP: Result code(2): 2: Call
disconnected, refer to error msg
*Nov 15 12:45:04.139: Error code(6): Vendor specific
*Nov 15 12:45:04.139: Optional msg: Locally generated disconnect
*Nov 15 12:45:04.139: uid:21 Tnl/Sn31399/10 L2TP: I CDN from rp1 tnl 9349, cl
13589
01:06:21: %VPDN-6-CLOSED: L2TP LNS 192.168.8.2 closed user nobody@example.com; Result
2, Error 6, Locally generated disconnect
*Nov 15 12:45:04.139: uid:21 Tnl/Sn31399/10 L2TP: disconnect (L2X) IETF:
18/host-request Ascend: 66/VPDN Local PPP Disconnect
*Nov 15 12:45:04.139: uid:21 Tnl/Sn31399/10 L2TP: Destroying session
*Nov 15 12:45:04.139: uid:21 Tnl/Sn31399/10 L2TP: Session state change from
established to idle
*Nov 15 12:45:04.139: VPDN MGR [uid:21]: Event peer disconnect, state changed from
connected to disconnected
*Nov 15 12:45:04.139: VPDN MGR [uid:21]: Remote disconnected nobody@example.com
*Nov 15 12:45:04.139: VPDN MGR [uid:21]: accounting stop sent
*Nov 15 12:45:04.139: Tnl31399 L2TP: Tunnel state change from established to
no-sessions-left
*Nov 15 12:45:04.143: Tnl31399 L2TP: No more sessions in tunnel, shutdown (likely)
in 15 seconds
*Nov 15 12:45:04.143: VPDN CALL [uid:21]: Event server disc, state changed from
connected to disconnected
*Nov 15 12:45:04.143: VPDN CALL [uid:21]: Server disconnected call
*Nov 15 12:45:04.143: VPDN CALL [uid:21]: Event free req, state changed from
disconnected to terminal
*Nov 15 12:45:04.143: VPDN CALL [uid:21]: Free request
*Nov 15 12:45:04.143: SSS MGR [uid:21]: Handling Send Client Disconnect
*Nov 15 12:45:04.143: [21]PPPoE 18: State CNCT_FWDED Event SSS_DISCNCT
*Nov 15 12:45:04.143: ppp21 PPP: Sending Acct_Event[Down] id[16]
*Nov 15 12:45:04.143: ppp21 PPP: Phase is TERMINATING
*Nov 15 12:45:04.143: ppp21 LCP: State is Closed
*Nov 15 12:45:04.143: ppp21 PPP: Phase is DOWN
*Nov 15 12:45:04.143: [21]PPPoE 18: O PADT R:0000.0c14.71d0 L:00b0.c2e9.c870 1/32
ATM4/0.132
*Nov 15 12:45:04.143: [21]PPPoE 18: Destroying R:0000.0c14.71d0 L:00b0.c2e9.c870
1/32 ATM4/0.132
*Nov 15 12:45:04.143: [21]PPPoE 18: AAA pppoe_aaa_acct_get_dynamic_attrs
*Nov 15 12:45:04.143: [21]PPPoE 18: AAA pppoe_aaa_acct_get_dynamic_attrs
*Nov 15 12:45:04.143: [21]PPPoE 18: AAA account stopped
*Nov 15 12:45:14.139: Tnl31399 L2TP: I StopCCN from rp1 tnl 9349
*Nov 15 12:45:14.139: Tnl31399 L2TP: Shutdown tunnel
*Nov 15 12:45:14.139: Tnl31399 L2TP: Tunnel state change from no-sessions-left

```

Troubleshooting the Subscriber Service Switch on the LNS--Normal Operation Example

The following example shows the **debug** commands used and sample output indicating normal operation of the Subscriber Service Switch on the LNS:

```

Router# debug sss event
Router# debug sss error
Router# debug sss fsm
Router# debug ppp negotiation

```

```

Router# debug vpdn l2x-events
Router# debug vpdn l2x-errors
Router# debug vpdn sss events
Router# debug vpdn sss errors
Router# debug vpdn sss fsm
SSS:
  SSS events debugging is on
  SSS error debugging is on
  SSS fsm debugging is on
PPP:
  PPP protocol negotiation debugging is on
VPN:
  L2X protocol events debugging is on
  L2X protocol errors debugging is on
  VPDN SSS events debugging is on
  VPDN SSS errors debugging is on
  VPDN SSS FSM debugging is on
3d17h: Tnl9264 L2TP: I ICRQ from server1 tnl 61510
3d17h: Tnl/Sn9264/13586 L2TP: Session FS enabled
3d17h: Tnl/Sn9264/13586 L2TP: Session state change from idle to wait-connect
3d17h: Tnl/Sn9264/13586 L2TP: New session created
3d17h: Tnl/Sn9264/13586 L2TP: O ICRP to server1 61510/7
3d17h: Tnl9264 L2TP: Control channel retransmit delay set to 1 seconds
3d17h: Tnl/Sn9264/13586 L2TP: I ICCN from server1 tnl 61510, cl 7
3d17h: nobody@example.com Tnl/Sn9264/13586 L2TP: Session state change from
wait-connect to wait-for-service-selection
3d17h: VPDN SSS [: Event start sss, state changed from IDLE to SSS
3d17h: VPDN SSS [uid:707]: Service request sent to SSS
3d17h: SSS INFO: Element type is Access-Type, long value is 4
3d17h: SSS INFO: Element type is Switch-Id, long value is 1493172561
3d17h: SSS INFO: Element type is Tunnel-Name, string value is server1
3d17h: SSS INFO: Element type is Can-SIP-Redirect, long value is 1
3d17h: SSS INFO: Element type is AAA-Id, long value is 16726
3d17h: SSS INFO: Element type is AccIe-Hdl, ptr value is D1000167
3d17h: SSS MGR [uid:707]: Event service-request, state changed from wait-for-req to
wait-for-auth
3d17h: SSS MGR [uid:707]: Handling Policy Authorize (1 pending sessions)
3d17h: SSS PM [uid:707]: RM/VPDN disabled: RM/VPDN author not needed
3d17h: SSS PM [uid:707]: Multihop disabled: AAA author not needed
3d17h: SSS PM [uid:707]: Multihop disabled: SGF author not needed
3d17h: SSS PM [uid:707]: No more authorization methods left to try, providing
default service
3d17h: SSS PM [uid:707]: Received Service Request
3d17h: SSS PM [uid:707]: Event <found>, State: initial-req to end
3d17h: SSS PM [uid:707]: Handling Service Direction
3d17h: SSS PM [uid:707]: Policy reply - Local terminate
3d17h: SSS MGR [uid:707]: Got reply Local-Term from PM
3d17h: SSS MGR [uid:707]: Event policy-connect local, state changed from
wait-for-auth to connected
3d17h: SSS MGR [uid:707]: Handling Send-Client-Local-Term event
3d17h: VPDN SSS [uid:707]: Event connect local, state changed from SSS to PPP
3d17h: ppp707 PPP: Phase is ESTABLISHING
3d17h: ppp707 LCP: I FORCED rcvd CONFACK len 15
3d17h: ppp707 LCP: MRU 1492 (0x010405D4)
3d17h: ppp707 LCP: AuthProto CHAP (0x0305C22305)
3d17h: ppp707 LCP: MagicNumber 0xB0EC4557 (0x0506B0EC4557)
3d17h: ppp707 LCP: I FORCED sent CONFACK len 10
3d17h: ppp707 LCP: MRU 1492 (0x010405D4)
3d17h: ppp707 LCP: MagicNumber 0x0017455D (0x05060017455D)
3d17h: ppp707 PPP: Phase is FORWARDING, Attempting Forward
3d17h: VPDN SSS [uid:707]: Event dyn bind resp, state changed from PPP to PPP
3d17h: ppp707 PPP: Phase is AUTHENTICATING, Unauthenticated User
3d17h: ppp707 PPP: Phase is FORWARDING, Attempting Forward
3d17h: VPDN SSS [uid:707]: Event connect local, state changed from PPP to PPP
3d17h: VPDN SSS [Vi4.2]: Event vaccess resp, state changed from PPP to PPP
3d17h: VPDN SSS [Vi4.2]: Event stat bind resp, state changed from PPP to CNCT
3d17h: Vi4.2 Tnl/Sn9264/13586 L2TP: Session state change from
wait-for-service-selection to established
3d17h: Vi4.2 PPP: Phase is AUTHENTICATING, Authenticated User
3d17h: Vi4.2 CHAP: O SUCCESS id 1 len 4
3d17h: Vi4.2 PPP: Phase is UP
3d17h: Vi4.2 IPCP: O CONFREQ [Closed] id 1 len 10
3d17h: Vi4.2 IPCP: Address 172.16.0.0 (0x030681010000)

```

```

3d17h: Vi4.2 PPP: Process pending packets
3d17h: Vi4.2 IPCP: I CONFREQ [REQsent] id 1 len 10
3d17h: Vi4.2 IPCP: Address 10.0.0.0 (0x030600000000)
3d17h: Vi4.2 AAA/AUTHOR/IPCP: Start. Her address 10.0.0.0, we want 10.0.0.0
3d17h: Vi4.2 AAA/AUTHOR/IPCP: Done. Her address 10.0.0.0, we want 10.0.0.0
3d17h: Vi4.2 IPCP: Pool returned 10.1.1.3
3d17h: Vi4.2 IPCP: O CONFNAK [REQsent] id 1 len 10
3d17h: Vi4.2 IPCP: Address 10.1.1.3 (0x03065B010103)
3d17h: Vi4.2 IPCP: I CONFACK [REQsent] id 1 len 10
3d17h: Vi4.2 IPCP: Address 172.16.0.0 (0x030681010000)
3d17h: Vi4.2 IPCP: I CONFREQ [ACKrcvd] id 2 len 10
3d17h: Vi4.2 IPCP: Address 10.1.1.3 (0x03065B010103)
3d17h: Vi4.2 IPCP: O CONFACK [ACKrcvd] id 2 len 10
3d17h: Vi4.2 IPCP: Address 10.1.1.3 (0x03065B010103)
3d17h: Vi4.2 IPCP: State is Open
3d17h: Vi4.2 IPCP: Install route to 10.1.1.3

```

Troubleshooting the Subscriber Service Switch on the LNS--Tunnel Failure Example

The following is sample output indicating tunnel failure on the LNS:

```

3d17h: L2TP: I SCCRQ from server1 tnl 31399
3d17h: Tnl9349 L2TP: Got a challenge in SCCRQ, server1
3d17h: Tnl9349 L2TP: New tunnel created for remote server1, address 192.168.8.1
3d17h: Tnl9349 L2TP: O SCCRP to server1 tnlid 31399
3d17h: Tnl9349 L2TP: Control channel retransmit delay set to 1 seconds
3d17h: Tnl9349 L2TP: Tunnel state change from idle to wait-ctl-reply
3d17h: Tnl9349 L2TP: I SCCCN from server1 tnl 31399
3d17h: Tnl9349 L2TP: Got a Challenge Response in SCCCN from server1
3d17h: Tnl9349 L2TP: Tunnel Authentication success
3d17h: Tnl9349 L2TP: Tunnel state change from wait-ctl-reply to established
3d17h: Tnl9349 L2TP: SM State established
3d17h: Tnl9349 L2TP: I ICRQ from server1 tnl 31399
3d17h: Tnl/Sn9349/13589 L2TP: Session FS enabled
3d17h: Tnl/Sn9349/13589 L2TP: Session state change from idle to wait-connect
3d17h: Tnl/Sn9349/13589 L2TP: New session created
3d17h: Tnl/Sn9349/13589 L2TP: O ICRP to server1 31399/10
3d17h: Tnl9349 L2TP: Control channel retransmit delay set to 1 seconds
3d17h: Tnl/Sn9349/13589 L2TP: I ICCN from server1 tnl 31399, cl 10
3d17h: nobody@example.com Tnl/Sn9349/13589 L2TP: Session state change from
wait-connect to wait-for-service-selection
3d17h: VPDN SSS []: Event start sss, state changed from IDLE to SSS
3d17h: VPDN SSS [uid:709]: Service request sent to SSS
3d17h: SSS INFO: Element type is Access-Type, long value is 4
3d17h: SSS INFO: Element type is Switch-Id, long value is -1912602284
3d17h: SSS INFO: Element type is Tunnel-Name, string value is server1
3d17h: SSS INFO: Element type is Can-SIP-Redirect, long value is 1
3d17h: SSS INFO: Element type is AAA-Id, long value is 16729
3d17h: SSS INFO: Element type is AccIe-Hdl, ptr value is 8D00016A
3d17h: SSS MGR [uid:709]: Event service-request, state changed from wait-for-req to
wait-for-auth
3d17h: SSS MGR [uid:709]: Handling Policy Authorize (1 pending sessions)
3d17h: SSS PM [uid:709]: RM/VPDN disabled: RM/VPDN author not needed
3d17h: SSS PM [uid:709]: Multihop disabled: AAA author not needed
3d17h: SSS PM [uid:709]: Multihop disabled: SGF author not needed
d17h: SSS PM [uid:709]: No more authorization methods left to try, providing default
service
3d17h: SSS PM [uid:709]: Received Service Request
3d17h: SSS PM [uid:709]: Event <found>, State: initial-req to end
3d17h: SSS PM [uid:709]: Handling Service Direction
3d17h: SSS PM [uid:709]: Policy reply - Local terminate
3d17h: SSS MGR [uid:709]: Got reply Local-Term from PM
3d17h: SSS MGR [uid:709]: Event policy-connect local, state changed from
wait-for-auth to connected
3d17h: SSS MGR [uid:709]: Handling Send-Client-Local-Term event
3d17h: VPDN SSS [uid:709]: Event connect local, state changed from SSS to PPP
3d17h: ppp709 PPP: Phase is ESTABLISHING
3d17h: ppp709 LCP: I FORCED rcvd CONFACK len 15
3d17h: ppp709 LCP: MRU 1492 (0x010405D4)
3d17h: ppp709 LCP: AuthProto CHAP (0x0305C22305)

```

```

3d17h: ppp709 LCP: MagicNumber 0xB0FFFA4D8 (0x0506B0FFFA4D8)
3d17h: ppp709 LCP: I FORCED sent CONFACK len 10
3d17h: ppp709 LCP: MRU 1492 (0x010405D4)
3d17h: ppp709 LCP: MagicNumber 0x002AA481 (0x0506002AA481)
3d17h: ppp709 PPP: Phase is FORWARDING, Attempting Forward
3d17h: VPDN SSS [uid:709]: Event dyn bind resp, state changed from PPP to PPP
3d17h: ppp709 PPP: Phase is AUTHENTICATING, Unauthenticated User
3d17h: ppp709 CHAP: O FAILURE id 1 len 25 msg is "Authentication failed"
3d17h: ppp709 PPP: Sending Acct Event[Down] id[4159]
3d17h: ppp709 PPP: Phase is TERMINATING
3d17h: ppp709 LCP: O TERMREQ [Open] id 1 len 4
3d17h: ppp709 LCP: State is Closed
3d17h: ppp709 PPP: Phase is DOWN
3d17h: ppp709 PPP: Phase is TERMINATING
3d17h: VPDN SSS [uid:709]: Event peer disc, state changed from PPP to DSC
3d17h: nobody@example.com Tnl/Sn9349/13589 L2TP: disconnect (AAA) IETF:
17/user-error Ascend: 26/PPP CHAP Fail
3d17h: nobody@example.com Tnl/Sn9349/13589 L2TP: O CDN to server1 31399/10
3d17h: Tnl9349 L2TP: Control channel retransmit delay set to 1 seconds
3d17h: nobody@example.com Tnl/Sn9349/13589 L2TP: Destroying session
3d17h: nobody@example.com Tnl/Sn9349/13589 L2TP: Session state change from
wait-for-service-selection to idle
3d17h: VPDN SSS [uid:709]: Event vpdn disc, state changed from DSC to END
3d17h: Tnl9349 L2TP: Tunnel state change from established to no-sessions-left
3d17h: Tnl9349 L2TP: No more sessions in tunnel, shutdown (likely) in 10 seconds
3d17h: SSS MGR [uid:709]: Processing a client disconnect
3d17h: SSS MGR [uid:709]: Event client-disconnect, state changed from connected to
end
3d17h: SSS MGR [uid:709]: Handling Send-Service-Disconnect event
3d17h: Tnl9349 L2TP: O StopCCN to server1 tnlid 31399
3d17h: Tnl9349 L2TP: Control channel retransmit delay set to 1 seconds
3d17h: Tnl9349 L2TP: Tunnel state change from no-sessions-left to shutting-down
3d17h: Tnl9349 L2TP: Shutdown tunnel

```

Where to Go Next

- If you want to establish PPPoE session limits for sessions on a specific permanent virtual circuit or VLAN configured on an L2TP access concentrator, refer to the "Establishing PPPoE Session Limits per NAS Port" module.
- If you want to use service tags to enable a PPPoE server to offer PPPoE clients a selection of service during call setup, refer to the "Offering PPPoE Clients a Selection of Services During Call Setup" module.
- If you want to enable an L2TP access concentrator to relay active discovery and service selection functionality for PPPoE over a L2TP control channel to an LNS or tunnel switch, refer to the "Enabling PPPoE Relay Discovery and Service Selection Functionality" module.
- If you want to configure a transfer upstream of the PPPoX session speed value, refer to the "Configuring Upstream Connections Speed Transfer" module.
- If you want to use the Simple Network Management Protocol (SNMP) to monitor PPPoE sessions, refer to the "Monitoring PPPoE Sessions with SNMP" module.
- If you want to identify a physical subscribe line for RADIUS communication with a RADIUS server, refer to the "Identifying a Physical Subscriber Line for RADIUS Access and Accounting" module.
- If you want to configure a Cisco Subscriber Service Switch, see the "Configuring Cisco Subscriber Service Switch Policies" module.

Additional References

The following sections provide references related to configuring Cisco Subscriber Service Switch policies.

Related Documents

Related Topic	Document Title
Broadband access aggregation concepts	Understanding Broadband Access Aggregation module
Tasks for preparing for broadband access aggregation.	Preparing for Broadband Access Aggregation module
Broadband access commands: complete command syntax, command mode, command history, defaults, usage guidelines, and examples	<i>Cisco IOS Broadband Access Aggregation and DSL Command Reference</i>
Configuration procedure for PPPoE.	Providing Protocol Support for Broadband Access Aggregation of PPPoE Sessions
Configuration procedures for PPPoA.	Providing Protocol Support for Broadband Access Aggregation of PPP over ATM Sessions

Standards

Standards	Title
None	--

MIBs

MIBs	MIBs Link
None	To locate and download MIBs for selected platforms, Cisco IOS XE software releases, and feature sets, use Cisco MIB Locator found at the following URL: http://www.cisco.com/go/mibs

RFCs

RFCs	Title
RFC 2661	Layer Two Tunneling Protocol L2TP
RFC 2341	Cisco Layer Two Forwarding (Protocol) L2F

RFCs	Title
RFC 2516	A Method for Transmitting PPP Over Ethernet (PPPoE) (PPPoE Discovery)

Technical Assistance

Description	Link
<p>The Cisco Support website provides extensive online resources, including documentation and tools for troubleshooting and resolving technical issues with Cisco products and technologies.</p> <p>To receive security and technical information about your products, you can subscribe to various services, such as the Product Alert Tool (accessed from Field Notices), the Cisco Technical Services Newsletter, and Really Simple Syndication (RSS) Feeds.</p> <p>Access to most tools on the Cisco Support website requires a Cisco.com user ID and password.</p>	http://www.cisco.com/techsupport

Feature Information for Configuring a Subscriber Service Switch Policy

The following table provides release information about the feature or features described in this module. This table lists only the software release that introduced support for a given feature in a given software release train. Unless noted otherwise, subsequent releases of that software release train also support that feature.

Use Cisco Feature Navigator to find information about platform support and Cisco software image support. To access Cisco Feature Navigator, go to www.cisco.com/go/cfn. An account on Cisco.com is not required.

Table 22: Feature Information for Configuring a Cisco Subscriber Service Switch Policy

Feature Name	Releases	Feature Configuration Information
Subscriber Service Switch	Cisco IOS XE Release 2.1	<p>The Subscriber Service Switch provides the framework for the management and scalability of PPP sessions that are switched from one virtual PPP link to another. It gives Internet service providers (ISPs) the flexibility to determining which services to provide to subscribers, the number of subscribers, and how to define the services. The primary purpose of the Subscriber Service Switch is to direct PPP from one point to another using a Layer 2 subscriber policy.</p> <p>This feature was integrated into Cisco IOS XE Release 2.1.</p>



AAA Improvements for Broadband IPv6

This feature provides AAA improvements for Broadband IPv6 support.

- [Finding Feature Information, page 195](#)
- [Information About AAA Improvements for Broadband IPv6, page 195](#)
- [How to Enable AAA Improvements for Broadband IPv6, page 200](#)
- [Configuration Examples for AAA Improvements for Broadband IPv6, page 201](#)
- [Additional References, page 201](#)
- [Feature Information for AAA Improvements for Broadband IPv6, page 202](#)

Finding Feature Information

Your software release may not support all the features documented in this module. For the latest caveats and feature information, see [Bug Search Tool](#) and the release notes for your platform and software release. To find information about the features documented in this module, and to see a list of the releases in which each feature is supported, see the feature information table.

Use Cisco Feature Navigator to find information about platform support and Cisco software image support. To access Cisco Feature Navigator, go to www.cisco.com/go/cfn. An account on Cisco.com is not required.

Information About AAA Improvements for Broadband IPv6

AAA over IPv6

Vendor-specific attributes (VSAs) are used to support Authentication, Authorization and Accounting(AAA) over IPv6. Cisco VSAs are `inACL`, `outACL`, `prefix`, and `route`.

You can configure prefix pools and pool names by using the AAA protocol. Customers can deploy an IPv6 RADIUS server or a TACACS+ server to communicate with Cisco devices.

AAA Support for IPv6 RADIUS Attributes

The following RADIUS attributes, as described in RFC 3162, are supported for IPv6:

- Framed-Interface-Id
- Framed-IPv6-Pool
- Framed-IPv6-Prefix
- Framed-IPv6-Route
- Login-IPv6-Host

The following RADIUS attributes are also supported for IPv6:

- Delegated-IPv6-Prefix (RFC 4818)
- Delegated-IPv6-Prefix-Pool
- DNS-Server-IPv6-Address
- IPv6 ACL
- IPv6_DNS_Servers
- IPv6 Pool
- IPv6 Prefix#
- IPv6 Route

The attributes listed above can be configured on a RADIUS server and downloaded to access servers, where they can be applied to access connections.

Prerequisites for Using AAA Attributes for IPv6

AAA attributes for IPv6 are compliant with RFC 3162 and require a RADIUS server capable of supporting RFC 3162.

RADIUS Per-User Attributes for Virtual Access in IPv6 Environments

The following IPv6 RADIUS attributes are supported for virtual access and can be used as attribute-value (AV) pairs:

- Delegated-IPv6-Prefix
- Delegated-IPv6-Prefix-Pool
- DNS-Server-IPv6-Address
- Framed-Interface-Id
- Framed-IPv6-Pool
- Framed-IPv6-Prefix
- Framed-IPv6-Route

- IPv6 ACL
- IPv6_DNS_Servers
- IPv6 Pool
- IPv6 Prefix#
- IPv6 Route
- Login-IPv6-Host

Delegated-IPv6-Prefix

The Delegated-IPv6-Prefix attribute indicates an IPv6 prefix to be delegated to a user for use in a network. This attribute is used during DHCP prefix delegation between a RADIUS server and a delegating device. A Network Access Server (NAS) that hosts a DHCP Version 6 (DHCPv6) server can act as a delegating device.

The following example shows how to use the Delegated-IPv6-Prefix attribute:

```
ipv6:delegated-prefix=2001:DB8::/64
```



Note

The Cisco VSA format is not supported for this attribute. If you try to add this attribute in the Cisco VSA format into a user profile, the RADIUS server response fails. Use only the IETF attribute format for this attribute.

Delegated-IPv6-Prefix-Pool

The Delegated-IPv6-Prefix-Pool attribute indicates the name of a prefix pool from which a prefix is selected and delegated to a device.

Prefix delegation is a DHCPv6 option for delegating IPv6 prefixes. Prefix delegation involves a delegating device that selects a prefix and assigns it on a temporary basis to a requesting device. A delegating device uses many strategies to choose a prefix. One method is to choose a prefix from a prefix pool with a name that is defined locally on a device.

The Delegated-IPv6-Prefix-Pool attribute indicates the name of an assigned prefix pool. A RADIUS server uses this attribute to communicate the name of a prefix pool to a NAS hosting a DHCPv6 server and acting as a delegating device.

You may use DHCPv6 prefix delegation along with ICMPv6 stateless address autoconfiguration (SLAAC) on a network. In this case, both the Delegated-IPv6-Prefix-Pool attribute and the Framed-IPv6-Pool attribute may be included within the same packet. To avoid ambiguity, the Delegated-IPv6-Prefix-Pool attribute should be restricted to the authorization and accounting of prefix pools used in DHCPv6 delegation, and the Framed-IPv6-Pool attribute should be used for the authorization and accounting of prefix pools used in SLAAC.

The following example shows how an address prefix is selected from a pool named pool1. The prefix pool pool1 is downloaded to a delegating device from a RADIUS server by using the Delegated-IPv6-Prefix-Pool attribute. The device then selects the address prefix 2001:DB8::/64 from this prefix pool.

```
Cisco:Cisco-AVpair = "ipv6:delegated-ipv6-pool = pool1"
!
ipv6 dhcp pool pool1
address prefix 2001:DB8::/64
!
```

DNS-Server-IPv6-Address

The DNS-Server-IPv6-Address attribute indicates the IPv6 address of a Domain Name System (DNS) server. A DHCPv6 server can configure a host with the IPv6 address of a DNS server. The IPv6 address of the DNS server can also be conveyed to the host using router advertisement messages from ICMPv6 devices.

A NAS may host a DHCPv6 server to handle DHCPv6 requests from hosts. The NAS may also act as a device that provides router advertisement messages. Therefore, this attribute is used to provide the NAS with the IPv6 address of the DNS server.

If a NAS has to announce more than one recursive DNS server to a host, this attribute can be included multiple times in Access-Accept packets sent from the NAS to the host.

The following example shows how you can define the IPv6 address of a DNS server by using the DNS-Server-IPv6-Address attribute:

```
Cisco:Cisco-AVpair = "ipv6:ipv6-dns-servers-addr=2001:DB8::"
```

Framed-Interface-Id

The Framed-Interface-Id attribute indicates an IPv6 interface identifier to be configured for a user.

This attribute is used during IPv6 Control Protocol (IPv6CP) negotiations of the Interface-Identifier option. If negotiations are successful, the NAS uses this attribute to communicate a preferred IPv6 interface identifier to the RADIUS server by using Access-Request packets. This attribute may also be used in Access-Accept packets.

Framed-IPv6-Pool

The Framed-IPv6-Pool attribute indicates the name of a pool that is used to assign an IPv6 prefix to a user. This pool should be either defined locally on a device or defined on a RADIUS server from where pools can be downloaded.

Framed-IPv6-Prefix

The Framed-IPv6-Prefix attribute indicates an IPv6 prefix (and a corresponding route) to be configured for a user. So this attribute performs the same function as a Cisco VSA and is used for virtual access only. A NAS uses this attribute to communicate a preferred IPv6 prefix to a RADIUS server by using Access-Request packets. This attribute may also be used in Access-Accept packets and can appear multiple times in these packets. The NAS creates a corresponding route for the prefix.

This attribute is used by a user to specify which prefixes to advertise in router advertisement messages of the Neighbor Discovery Protocol.

This attribute can also be used for DHCPv6 prefix delegation, and a separate profile must be created for a user on the RADIUS server. The username associated with this separate profile has the suffix "-dhcpv6".

The Framed-IPv6-Prefix attribute is treated differently in this separate profile and the regular profile of a user. If a NAS needs to send a prefix through router advertisement messages, the prefix is placed in the Framed-IPv6-Prefix attribute of the regular profile of the user. If a NAS needs to delegate a prefix to the network of a remote user, the prefix is placed in the Framed-IPv6-Prefix attribute of the separate profile of the user.



Note

The RADIUS IETF attribute format and the Cisco VSA format are supported for this attribute.

Framed-IPv6-Route

The Framed-IPv6-Route attribute indicates the routing information to be configured for a user on a NAS. This attribute performs the same function as a Cisco VSA. The value of the attribute is a string and is specified by using the **ipv6 route** command.

IPv6 ACL

The IPv6 ACL attribute is used to specify a complete IPv6 access list. The unique name of an access list is generated automatically. An access list is removed when the respective user logs out. The previous access list on the interface is then reapplied.

The `inacl` and `outacl` attributes enable you to specify an existing access list configured on a device. The following example shows how to define an access list identified with number 1:

```
cisco-avpair = "ipv6:inacl#1=permit 2001:DB8:cc00:1::/48",  
cisco-avpair = "ipv6:outacl#1=deny 2001:DB8::/10",
```

IPv6_DNS_Servers

The IPv6_DNS_Servers attribute is used to send up to two DNS server addresses to the DHCPv6 server. The DNS server addresses are saved in the interface DHCPv6 subblock and override other configurations in the DHCPv6 pool. This attribute is also included in attributes returned for AAA start and stop notifications.

IPv6 Pool

The IPv6 Pool attribute extends the IPv4 address pool attribute to support the IPv6 protocol for RADIUS authentication. This attribute specifies the name of a local pool on a NAS from which a prefix is chosen and used whenever PPP is configured and the protocol is specified as IPv6. The address pool works with local pooling and specifies the name of a local pool that is preconfigured on the NAS.

IPv6 Prefix#

The IPv6 Prefix# attribute indicates which prefixes to advertise in router advertisement messages of the Neighbor Discovery Protocol. When this attribute is used, a corresponding route (marked as a per-user static route) is installed in the routing information base (RIB) tables for a given prefix.

The following example shows how to specify which prefixes to advertise:

```
cisco-avpair = "ipv6:prefix#1=2001:DB8::/64",  
cisco-avpair = "ipv6:prefix#2=2001:DB8::/64",
```

IPv6 Route

The IPv6 Route attribute is used to specify a static route for a user. A static route is appropriate when Cisco software cannot dynamically build a route to the destination. See the **ipv6 route** command for more information about building static routes.

The following example shows how to use the IPv6 Route attribute to define a static route:

```
cisco-avpair = "ipv6:route#1=2001:DB8:cc00:1::/48",  
cisco-avpair = "ipv6:route#2=2001:DB8:cc00:2::/48",
```

Login-IPv6-Host

The Login-IPv6-Host attribute indicates IPv6 addresses of hosts with which to connect a user when the Login-Service attribute is included. A NAS uses the Login-IPv6-Host attribute in Access-Request packets to communicate to a RADIUS server that it prefers to use certain hosts.

How to Enable AAA Improvements for Broadband IPv6

Sending IPv6 Counters to the Accounting Server

SUMMARY STEPS

1. `enable`
2. `configure terminal`
3. `aaa accounting send counters ipv6`

DETAILED STEPS

Step 1 `enable`

Example:

```
Device> enable
```

Enables privileged EXEC mode.

- Enter your password if prompted.

Step 2 `configure terminal`

Example:

```
Device# configure terminal
```

Enters global configuration mode.

Step 3 `aaa accounting send counters ipv6`

Example:

```
Device(config)# aaa accounting send counters ipv6
```

Sends IPv6 counters in the stop record to the accounting server.

Configuration Examples for AAA Improvements for Broadband IPv6

Example: Sending IPv6 Counters to the Accounting Server

```
Device# show running-config
aaa new-model
aaa authentication ppp default group radius
aaa authorization network default group radius
aaa accounting send counters ipv6
aaa accounting network default
    action-type start-stop
    group radius
```

Additional References

Related Documents

Related Topic	Document Title
IPv6 addressing and connectivity	<i>IPv6 Configuration Guide</i>
Cisco IOS commands	Cisco IOS Master Commands List, All Releases
IPv6 commands	Cisco IOS IPv6 Command Reference
Cisco IOS IPv6 features	Cisco IOS IPv6 Feature Mapping

Standards and RFCs

Standard/RFC	Title
RFCs for IPv6	

MIBs

MIB	MIBs Link
	To locate and download MIBs for selected platforms, Cisco IOS releases, and feature sets, use Cisco MIB Locator found at the following URL: http://www.cisco.com/go/mibs

Technical Assistance

Description	Link
The Cisco Support and Documentation website provides online resources to download documentation, software, and tools. Use these resources to install and configure the software and to troubleshoot and resolve technical issues with Cisco products and technologies. Access to most tools on the Cisco Support and Documentation website requires a Cisco.com user ID and password.	http://www.cisco.com/cisco/web/support/index.html

Feature Information for AAA Improvements for Broadband IPv6

The following table provides release information about the feature or features described in this module. This table lists only the software release that introduced support for a given feature in a given software release train. Unless noted otherwise, subsequent releases of that software release train also support that feature.

Use Cisco Feature Navigator to find information about platform support and Cisco software image support. To access Cisco Feature Navigator, go to www.cisco.com/go/cfn. An account on Cisco.com is not required.

Table 23: Feature Information for AAA Improvements for Broadband IPv6

Feature Name	Releases	Feature Information
AAA Improvements for Broadband IPv6	Cisco IOS XE Release 2.5	The AAA attributes for IPv6 are compliant with RFC 3162 and require a RADIUS server capable of supporting RFC 3162. The following commands were introduced or modified: aaa accounting send counters ipv6 .



Per Session Queueing and Shaping for PPPoEoVLAN Using RADIUS

The Per Session Queueing and Shaping for PPPoEoVLAN Using RADIUS feature enables you to shape PPP over Ethernet over VLAN sessions to a user-specified rate. The router shapes the sum of all of the traffic to the PPPoE session so that the subscriber's connection to the digital subscriber line access multiplexer (DSLAM) does not become congested. Queueing-related functionality provides different levels of service to the various applications that execute over the PPPoE session.

A nested, two-level hierarchical service policy is used to configure session shaping directly on the router using the modular quality of service command-line interface (MQC). The RADIUS server applies the service policy to a particular PPPoE session by downloading a RADIUS attribute to the router. This attribute specifies the policy map name to apply to the session. RADIUS notifies the router to apply the specified policy to the session. Because the service policy contains queueing-related actions, the router sets up the appropriate class queues and creates a separate versatile traffic management and shaping (VTMS) system link dedicated to the PPPoE session.

- [Finding Feature Information, page 203](#)
- [Restrictions for Per Session Queueing and Shaping for PPPoEoVLAN Using RADIUS, page 204](#)
- [Information About Per Session Queueing and Shaping for PPPoEoVLAN Using RADIUS, page 204](#)
- [How to Use the Per Session Queueing and Shaping for PPPoEoVLAN Using RADIUS Feature, page 207](#)
- [Configuration Examples for Per Session Queueing and Shaping Policies, page 210](#)
- [Additional References, page 213](#)
- [Feature Information for Per Session Queueing and Shaping for PPPoEoVLAN Using RADIUS, page 214](#)

Finding Feature Information

Your software release may not support all the features documented in this module. For the latest caveats and feature information, see [Bug Search Tool](#) and the release notes for your platform and software release. To find information about the features documented in this module, and to see a list of the releases in which each feature is supported, see the feature information table.

Use Cisco Feature Navigator to find information about platform support and Cisco software image support. To access Cisco Feature Navigator, go to www.cisco.com/go/cfn. An account on Cisco.com is not required.

Restrictions for Per Session Queueing and Shaping for PPPoEoVLAN Using RADIUS

- Each PPPoE over VLAN session for which per session queueing and shaping is configured has its own set of queues and its own VTMS link. Therefore, these PPPoE sessions do not inherit policies unless you remove the service policy applied to the session or you do not configure a policy for the session.
- The router supports per session queueing and shaping on PPPoE terminated sessions and on an IEEE 802.1Q VLAN tagged subinterfaces for outbound traffic only.
- The router does not support per session queueing and shaping for PPPoE over VLAN sessions using RADIUS on inbound interfaces.
- The router does not support per session queueing and shaping for layer 2 access concentrator (LAC) sessions.
- The statistics related to quality of service (QoS) that are available using the **show policy-map interface** command are not available using RADIUS.
- The router does not support using a virtual template interface to apply a service policy to a session.
- You can apply per session queueing and shaping policies only as output service policies. The router supports input service policies on sessions for other existing features, but not for per session queueing and shaping for PPPoE over VLAN using RADIUS.
- During periods of congestion, the router does not provide specific scheduling between the various PPPoE sessions. If the entire port becomes congested, the scheduling that results has the following effects:
 - The amount of bandwidth that each session receives of the entire port's capacity is not typically proportionally fair share.
 - The contribution of each class queue to the session's total bandwidth might not degrade proportionally.
- The PRE2 does not support ATM overhead accounting for egress packets with Ethernet encapsulations. Therefore, the router does not consider ATM overhead calculations when determining that the shaping rate conforms to contracted subscriber rates.
- The router does not support the configuration of the policy map using RADIUS. You must use the MQC to configure the policy map on the router.

Information About Per Session Queueing and Shaping for PPPoEoVLAN Using RADIUS

The router allows you to apply QoS policy maps using RADIUS. The actual configuration of the policy map occurs on the router using the MQC.

How Routers Apply QoS Policy to Sessions

The router can apply the QoS policy to sessions using attributes defined in one of the following RADIUS profiles:

- **User Profile**--The user profile on the RADIUS server contains an entry that identifies the policy map name applicable to the user. The policy map name is the service that RADIUS downloads to the router after a session is authorized.
- **Service Profile**--The service profile on the RADIUS server specifies a session identifier and an attribute-value (AV) pair. The session identifier might be, for example, the IP address of the session. The AV-pair defines the service (policy map name) to which the user belongs.

The following AV-pairs define the QoS policy to be applied dynamically to the session:

```
"ip:sub-qos-policy-in=<name of the QoS policy in ingress direction>"
```

```
"ip:sub-qos-policy-out=<name of egress policy>"
```

When RADIUS gets a service-logon request from the policy server, it sends a change of authorization (CoA) request to the router to activate the service for the subscriber, who is already logged in.

If the authorization succeeds, the router downloads the name of the policy map from RADIUS using the above attribute and applies the QoS policy to the session.

**Note**

Although the router also supports the RADIUS VSA 38, Cisco-Policy-Down and Cisco-Policy-Up, we recommend that you use the above attributes for QoS policy definitions.

How RADIUS Uses VSA 38 in User Profiles

The RADIUS VSA 38 is used for downstream traffic going toward a subscriber. The service (policy map name) to which the user session belongs resides on the RADIUS server. The router downloads the name of the policy map from RADIUS using VSA 38 in the user profile and then applies the policy to the session.

To set up RADIUS for per session queuing and shaping for PPPoE over VLAN support, enter the following VSA in the user profile on the RADIUS server:

```
Cisco: Cisco-Policy-Down = <service policy name>
```

The actual configuration of the policy map occurs on the router. The user profile on the RADIUS service contains an entry that identifies the policy map name applicable to the user. This policy map name is the service RADIUS downloads to the router using VSA 38.

**Note**

Although the router also supports RADIUS VSA 38, Cisco-Policy-Down and Cisco-Policy-Up, we recommend that you use the attributes described in the [How Routers Apply QoS Policy to Sessions, on page 205](#) for QoS policy definitions.

Commands Used to Define QoS Actions

When you configure queueing and shaping for PPPoE over VLAN sessions, the child policy of a nested hierarchical service policy defines QoS actions using any of the following QoS commands:

- **priority** command--Assigns priority to a traffic class and gives preferential treatment to the class.
- **bandwidth** command--Enables class-based fair queueing and creates multiple class queues based on bandwidth.
- **queue-limit** command--Specifies the maximum number of packets that a particular class queue can hold.
- **police** command--Regulates traffic based on bits per second (bps), using the committed information rate (CIR) and the peak information rate, or on the basis of a percentage of bandwidth available on an interface.
- **random-detect** command--Drops packets based on a specified value to control congestion before a queue reaches its queue limit. The drop policy is based on IP precedence, differentiated services code point (DSCP), or the discard-class.
- **set ip precedence** command--Marks a packet with the IP precedence level you specify.
- **set dscp** command--Marks a packet with the DSCP you specify.
- **set cos** command--Sets the IEEE 802.1Q class of service bits in the user priority field.

The parent policy contains only the class-default class with the **shape** command configured. This command shapes traffic to the specified bit rate, according to a specific algorithm.

The router allows you to apply QoS policy maps using RADIUS. The actual configuration of the policy map occurs on the router using the MQC. The router can apply the QoS policy to sessions using attributes defined in one of the following RADIUS profiles:

- **User Profile**--The user profile on the RADIUS server contains an entry that identifies the policy map name applicable to the user. The policy map name is the service that RADIUS downloads to the router after a session is authorized.
- **Service Profile**--The service profile on the RADIUS server specifies a session identifier and an attribute-value (AV) pair. The session identifier might be, for example, the IP address of the session. The AV-pair defines the service (policy map name) to which the user belongs.

The following AV-pairs define the QoS policy to be applied dynamically to the session:

```
"ip:sub-qos-policy-in=<name of the QoS policy in ingress direction>"
```

```
"ip:sub-qos-policy-out=<name of egress policy>"
```

When RADIUS gets a service-logon request from the policy server, it sends a change of authorization (CoA) request to the router to activate the service for the subscriber, who is already logged in.

If the authorization succeeds, the router downloads the name of the policy map from RADIUS using the above attribute and applies the QoS policy to the session.

**Note**

Although the router also supports the RADIUS vendor specific attribute (VSA) 38, Cisco-Policy-Down and Cisco-Policy-Up, we recommend that you use the above attributes for QoS policy definitions.

How to Use the Per Session Queueing and Shaping for PPPoEoVLAN Using RADIUS Feature

Configuring a Per Session Queueing and Shaping Policy on the Router

To configure a per session queueing and shaping policy on the router for PPPoE over VLAN sessions using RADIUS, you must complete the following steps.

SUMMARY STEPS

1. **policy-map** *policy-map-name*
2. **class**
3. **bandwidth** {*bandwidth-kbps* | **percent** *percentage* | **remaining percent** *percentage*} **account** {{**qinq** | **dot1q**} {**aal5** | **aal3**} {*subscriber-encapsulation*}} | {**user-defined** *offset* [**atm**]}}
4. **exit**
5. **policy-map** *policy-map-name*
6. **class** *class-default*
7. **shape** *rate* **account** {{{**qinq** | **dot1q**} {**aal5** | **aal3**} {*subscriber-encapsulation*}} | {**user-defined** *offset* [**atm**]}}
8. **service-policy** *policy-map-name*

DETAILED STEPS

	Command or Action	Purpose
Step 1	policy-map <i>policy-map-name</i> Example: <pre>Router(config)# policy-map policy-map-name</pre>	Creates or modifies the bottom-level child policy. <ul style="list-style-type: none"> • <i>policy-map-name</i> is the name of the child policy map. The name can be a maximum of 40 alphanumeric characters.
Step 2	class Example: <pre>Router(config-pmap)# class class-map-name</pre>	Assigns the traffic class you specify to the policy map. Enters policy-map class configuration mode. <ul style="list-style-type: none"> • <i>class-map-name</i> is the name of a previously configured class map and is the traffic class for which you want to define QoS actions. • Repeat Steps 2 and 3 for each traffic class you want to include in the policy map.

	Command or Action	Purpose
Step 3	<p>bandwidth {<i>bandwidth-kbps</i> percent <i>percentage</i> remaining percent <i>percentage</i>} account {{qinq dot1q} {aal5 aal3} {<i>subscriber-encapsulation</i>}} {user-defined <i>offset</i> [atm]}</p> <p>Example:</p> <pre>Router(config-pmap-c)# bandwidth {bandwidth-kbps percent percentage remaining percent percentage} account {{qinq dot1q} {aal5 aal3} subscriber-encapsulation user-defined offset [atm]}</pre>	<p>Enables class-based fair queueing.</p> <ul style="list-style-type: none"> • <i>bandwidth-kbps</i> specifies or modifies the minimum bandwidth allocated for a class belonging to a policy map. Valid values are from 8 to 2488320, which represents from 1 to 99 percent of the link bandwidth. • percent <i>percentage</i> specifies or modifies the minimum percentage of the link bandwidth allocated for a class belonging to a policy map. Valid values are from 1 to 99. • remaining percent <i>percentage</i> specifies or modifies the minimum percentage of unused link bandwidth allocated for a class belonging to a policy map. Valid values are from 1 to 99. • account enables ATM overhead accounting. For more information, see the "ATM Overhead Accounting" section of the "Configuring Dynamic Subscriber Services" chapter of the <i>Cisco 10000 Series Router Quality of Service Configuration Guide</i>. • qinq specifies queue-in-queue encapsulation as the broadband aggregation system-DSLAM encapsulation type. • dot1q specifies IEEE 802.1Q VLAN encapsulation as the broadband aggregation system-DSLAM encapsulation type. • aal5 specifies the ATM Adaptation Layer 5 that supports connection-oriented variable bit rate (VBR) services. You must specify either aal5 or aal3. • aal3 specifies the ATM Adaptation Layer 5 that supports both connectionless and connection-oriented links. You must specify either aal3 or aal5. • <i>subscriber-encapsulation</i> specifies the encapsulation type at the subscriber line. • user-defined indicates that the router is to use the <i>offset</i> you specify when calculating ATM overhead. • <i>offset</i> specifies the offset size the router is to use when calculating ATM overhead. Valid values are from -63 to 63 bytes. <p>Note The router configures the offset size if you do not specify the <i>offset</i> option.</p> <ul style="list-style-type: none"> • atm applies ATM cell tax in the ATM overhead calculation.
Step 4	<p>exit</p> <p>Example:</p> <pre>Router(config-pmap-c)# exit</pre>	<p>Exits policy-map class configuration mode.</p>
Step 5	<p>policy-map <i>policy-map-name</i></p>	<p>Creates or modifies the parent policy.</p>

	Command or Action	Purpose
	<p>Example:</p> <pre>Router(config-pmap)# policy-map policy-map-name</pre>	<ul style="list-style-type: none"> <i>policy-map-name</i> is the name of the parent policy map. The name can be a maximum of 40 alphanumeric characters.
Step 6	<p>class <i>class-default</i></p> <p>Example:</p> <pre>Router(config-pmap)# class class-default</pre>	<p>Configures or modifies the parent class-default class.</p> <p>Note You can configure only the class-default class in a parent policy. Do not configure any other traffic class.</p>
Step 7	<p>shape <i>rate</i> account {{{qinq dot1q}{aal5 aal3}{<i>subscriber-encapsulation</i>}} {user-defined <i>offset</i> [atm]}}</p> <p>Example:</p> <pre>Router(config-pmap-c)# shape rate account {qinq dot1q} {aal5 aal3} subscriber-encapsulation {user-defined offset [atm]}</pre>	<p>Shapes traffic to the indicated bit rate and enables ATM overhead accounting.</p> <ul style="list-style-type: none"> <i>rate</i> is the bit-rate used to shape the traffic, expressed in kilobits per second. account enables ATM overhead accounting. qinq specifies queue-in-queue encapsulation as the broadband aggregation system-DSLAM encapsulation type. dot1q specifies IEEE 802.1Q VLAN encapsulation as the broadband aggregation system-DSLAM encapsulation type. aal5 specifies the ATM Adaptation Layer 5 that supports connection-oriented VBR services. You must specify either aal5 or aal3. aal3 specifies the ATM Adaptation Layer 5 that supports both connectionless and connection-oriented links. You must specify either aal3 or aal5. <i>subscriber-encapsulation</i> specifies the encapsulation type at the subscriber line. user-defined indicates that the router is to use the <i>offset</i> you specify when calculating ATM overhead. <i>offset</i> specifies the offset size the router is to use when calculating ATM overhead. Valid values are from -63 to 63 bytes. <p>Note The router configures the offset size if you do not specify the user-defined <i>offset</i> option.</p> <ul style="list-style-type: none"> atm applies ATM cell tax in the ATM overhead calculation.
Step 8	<p>service-policy <i>policy-map-name</i></p> <p>Example:</p> <pre>Router(config-pmap-c)# service-policy policy-map-name</pre>	<p>Applies a bottom-level child policy to the top-level parent class-default class.</p> <ul style="list-style-type: none"> <i>policy-map-name</i> is the name of the previously configured child policy map.

Verifying Per Session Queueing

To display the configuration of per session queueing and shaping policies for PPPoE over VLAN, enter any of the following commands in privileged EXEC mode:

Command	Purpose
Router# show policy-map interface interface	Displays information about the policy map attached to the interface you specify. If you do not specify an interface, it displays information about all of the policy maps configured on the router. <ul style="list-style-type: none"> • <i>interface</i> specifies the virtual-access interface and number the router created for the session (for example, virtual-access 1).
Router# show policy-map session uid uid-number	Displays the session QoS counters for the subscriber session you specify. <ul style="list-style-type: none"> • uid <i>uid-number</i> defines a unique session ID. Valid values for <i>uid-number</i> are from 1 to 65535.
Router# show running-config	Displays the running configuration on the router. The output shows the AAA setup and the configuration of the policy map, ATM VC, PPPoA, dynamic bandwidth selection, virtual template, and RADIUS server.

Configuration Examples for Per Session Queueing and Shaping Policies

Configuring a Per Session Queueing and Shaping Policy on the Router Example

The following example shows

The example creates two traffic classes: Voice and Video. The router classifies traffic that matches IP precedence 5 as Voice traffic and traffic that matches IP precedence 3 as Video traffic. The Child policy map gives priority to Voice traffic and polices traffic at 2400 kbps. The Video class is allocated 80 percent of the remaining bandwidth and has ATM overhead accounting enabled. The Child policy is applied to the class-default class of the Parent policy map, which receives 20 percent of the remaining bandwidth and shapes traffic to 10,000 bps, and has ATM overhead accounting enabled.

```
Router(config)# class-map Voice
Router(config-cmap)# match ip precedence 5
Router(config-cmap)# class-map Video
```

```

Router(config-cmap)# match ip precedence 3
!
Router(config)# policy-map Child
Router(config-pmap)# class Voice
Router(config-pmap-c)# priority
Router(config-pmap-c)# police 2400 9216 0 conform-action transmit exceed-action drop
violate-action drop
Router(config-pmap-c)# class video
Router(config-pmap-c)# bandwidth remaining percent 80 account aal5 snap-dot1q-rbe
Router(config-pmap-c)# exit
Router(config-pmap)# exit
Router(config)# policy-map Parent
Router(config-pmap)# class class-default
Router(config-pmap-c)# shape 10000 account dot1q snap-dot1q-rbe
Router(config-pmap-c)# service-policy Child

```

Setting Up RADIUS for Per Session Queueing and Shaping Example

The following are example configurations for the Merit RADIUS server and the associated Layer 2 network server (LNS). In the example, the Cisco-Policy-Down attribute indicates the name of the policy map to be downloaded, which in this example is rad-output-policy. The RADIUS dictionary file includes an entry for Cisco VSA 38.

```

example.com Password = "cisco123"
Service-Type = Framed-User,
Framed-Protocol = PPP,
Cisco: Cisco-Policy-Down = rad-output-policy
Cisco.attr Cisco-Policy-Up 37 string (*, *)
Cisco.attr Cisco-Policy-Down 38 string (*, *)

```

Verifying Per Session Queueing and Shaping Policies Examples

This example shows sample output for the **show policy-map interface** command

```

Router# show policy-map interface virtual-access 1
!
!
Service-policy output: TEST
Class-map: class-default (match-any)
100 packets, 1000 bytes
30 second offered rate 800 bps, drop rate 0 bps
Match: any
shape (average) cir 154400, bc 7720, be 7720
target shape rate 154400
overhead accounting: enabled
bandwidth 30% (463 kbps)
overhead accounting: disabled
queue limit 64 packets
(queue depth/total drops/no-buffer drops) 0/0/0
(pkts output/bytes output) 100/1000

```

This example shows sample output from the **show policy-map session** command and **show policy-map session uid** command, based on a nested hierarchical policy.

```

Router# show subscriber session
Current Subscriber Information: Total sessions 1
Uniq ID Interface State Service Identifier Up-time
36 Vi2.1 authen Local Term peapen@cisco.com 00:01:36
Router# show policy-map parent
Policy Map parent
Class class-default

```

```

Average Rate Traffic Shaping
cir 10000000 (bps)
service-policy child
Router# show policy-map child

Policy Map child
Class voice
  priority
  police 8000 9216 0
  conform-action transmit
  exceed-action drop
  violate-action drop
Class video
  bandwidth remaining 80 (%)
Router# show policy-map session uid 36
SSS session identifier 36 -
SSS session identifier 36 -
Service-policy output: parent
Class-map: class-default (match-any)
  0 packets, 0 bytes
  30 second offered rate 0 bps, drop rate 0 bps
Match: any
  0 packets, 0 bytes
  30 second rate 0 bps
Queueing
queue limit 250 packets
(queue depth/total drops/no-buffer drops) 0/0/0
(pkts output/bytes output) 0/0
shape (average) cir 10000000, bc 40000, be 40000
target shape rate 10000000
Service-policy : child
  queue stats for all priority classes:
    Queueing
    queue limit 16 packets
    (queue depth/total drops/no-buffer drops) 0/0/0
    (pkts output/bytes output) 0/0
  Class-map: voice (match-all)
  0 packets, 0 bytes
  30 second offered rate 0 bps, drop rate 0 bps
  Match: ip precedence 5
  Priority: Strict, burst bytes 1500, b/w exceed drops: 0

  Police:
    8000 bps, 9216 limit, 0 extended limit
    conformed 0 packets, 0 bytes; action:
    transmit
    exceeded 0 packets, 0 bytes; action:
    drop
    violated 0 packets, 0 bytes; action:
    drop
  Class-map: video (match-all)
  0 packets, 0 bytes
  30 second offered rate 0 bps, drop rate 0 bps
  Match: ip precedence 3
  Queueing
  queue limit 250 packets
  (queue depth/total drops/no-buffer drops) 0/0/0
  (pkts output/bytes output) 0/0
  bandwidth remaining 80% (7993 kbps)
  Class-map: class-default (match-any)
  0 packets, 0 bytes
  30 second offered rate 0 bps, drop rate 0 bps
  Match: any
  0 packets, 0 bytes
  30 second rate 0 bps
  queue limit 250 packets
  (queue depth/total drops/no-buffer drops) 0/0/0
  (pkts output/bytes output) 2/136

```

Additional References

The following sections provide references related to the Per Session Queueing and Shaping for PPPoEoVLAN Using RADIUS feature.

Standards

Standard	Title
No new or modified standards are supported, and support for existing standards has not been modified.	--

MIBs

MIB	MIBs Link
No new or modified MIBs are supported, and support for existing MIBs has not been modified.	To locate and download MIBs for selected platforms, Cisco IOS XE software releases, and feature sets, use Cisco MIB Locator found at the following URL: http://www.cisco.com/go/mibs

RFCs

RFC	Title
No new or modified RFCs are supported, and support for existing RFCs has not been modified.	--

Technical Assistance

Description	Link
<p>The Cisco Support website provides extensive online resources, including documentation and tools for troubleshooting and resolving technical issues with Cisco products and technologies.</p> <p>To receive security and technical information about your products, you can subscribe to various services, such as the Product Alert Tool (accessed from Field Notices), the Cisco Technical Services Newsletter, and Really Simple Syndication (RSS) Feeds.</p> <p>Access to most tools on the Cisco Support website requires a Cisco.com user ID and password.</p>	http://www.cisco.com/techsupport

Feature Information for Per Session Queueing and Shaping for PPPoEoVLAN Using RADIUS

The following table provides release information about the feature or features described in this module. This table lists only the software release that introduced support for a given feature in a given software release train. Unless noted otherwise, subsequent releases of that software release train also support that feature.

Use Cisco Feature Navigator to find information about platform support and Cisco software image support. To access Cisco Feature Navigator, go to www.cisco.com/go/cfn. An account on Cisco.com is not required.

Table 24: Feature Information for Per Session Queueing and Shaping for PPPoE over VLAN Using RADIUS

Feature Name	Releases	Feature Information
Per Session Queueing and Shaping for PPPoE over VLAN Using RADIUS	Cisco IOS XE Release 2.1	<p>This feature enables you to shape PPPoE over VLAN sessions to a user-specified rate. The Per Session Queueing and Shaping for PPPoE over VLAN Support Using RADIUS feature was introduced on the PRE2 to enable dynamic queueing and shaping policies on PPPoEoVLAN session.</p> <p>This feature was integrated into Cisco IOS XE Release 2.1.</p>



802.1P CoS Bit Set for PPP and PPPoE Control Frames

The 802.1P CoS Bit Set for PPP and PPPoE Control Frames feature provides the ability to set user priority bits in the IEEE 802.1Q tagged frame to allow traffic prioritization. This capability enables a way to provide best-effort quality of service (QoS) or class of service (CoS) at Layer 2 without requiring reservation setup.

- [Finding Feature Information, page 215](#)
- [Prerequisites for 802.1P CoS Bit Set for PPP and PPPoE Control Frames, page 215](#)
- [Restrictions for 802.1P CoS Bit Set for PPP and PPPoE Control Frames, page 216](#)
- [Information About 802.1P CoS Bit Set for PPP and PPPoE Control Frames, page 216](#)
- [How to Configure 802.1P CoS Bit Set for PPP and PPPoE Control Frames, page 217](#)
- [Configuration Examples for 802.1P CoS Bit Set for PPP and PPPoE Control Frames, page 217](#)
- [Additional References, page 219](#)
- [Feature Information for 802.1P CoS Bit Set for PPP and PPPoE Control Frames, page 220](#)

Finding Feature Information

Your software release may not support all the features documented in this module. For the latest caveats and feature information, see [Bug Search Tool](#) and the release notes for your platform and software release. To find information about the features documented in this module, and to see a list of the releases in which each feature is supported, see the feature information table.

Use Cisco Feature Navigator to find information about platform support and Cisco software image support. To access Cisco Feature Navigator, go to www.cisco.com/go/cfn. An account on Cisco.com is not required.

Prerequisites for 802.1P CoS Bit Set for PPP and PPPoE Control Frames

The PPPoE over 802.1Q VLAN feature must be enabled.

Restrictions for 802.1P CoS Bit Set for PPP and PPPoE Control Frames

You cannot set different CoS levels for PPP and Point-to-Point Protocol over Ethernet (PPPoE) control packets; all control packets default to a CoS level set at 0.

Information About 802.1P CoS Bit Set for PPP and PPPoE Control Frames

To configure the 802.1P CoS Bit Set for PPP and PPPoE Control Frames feature, you should understand the following concepts:

The command can help troubleshoot 802.1P control frame marking: **debug pppoe error**

Benefits of 802.1P CoS Bit Set for PPP and PPPoE Control Frames

The 802.1P CoS Bit Set for PPP and PPPoE Control Frames feature facilitates moving from ATM-based to Ethernet-based networks by supporting the ability to offer prioritized traffic services, Voice over Internet Protocol (VoIP), and other premium services.

Feature Design of 802.1P CoS Bit Set for PPP and PPPoE Control Frames

The IEEE 802.1P specification is an extension of the IEEE 802.1Q VLANs tagging standard and enables Layer 2 devices to prioritize traffic by using an 802.1P header that includes a three-bit user priority field. If congestion occurs when the 802.1P CoS bit is not set, PPP keepalive packets can be lost, which can result in disconnection of an established session with loss of service to the end user. Congestion caused by noncontrol packets can also prevent new sessions from being established, which also can result in denying service to the end user.

PPPoE sessions established over 802.1Q VLANs use the priority header field to provide best-effort QoS or CoS at Layer 2 without involving reservation setup. 802.1P traffic is marked and sent to the destination, and no bandwidth reservations are established.

In Cisco IOS XE Release 2.4, PPPoE sessions established over IEEE 802.1Q VLAN make use of the priority field of the IEEE 802.1p header by setting the CoS field to user priority 7.

During network congestion, when the Ethernet network and digital subscriber line access multiplexer (DSLAM) offer 802.1P support, control packets are offered a higher priority than noncontrol packets, thereby increasing the likelihood of reliable delivery. PPPoE control packets and PPP packets originating from the broadband remote access server (BRAS) are marked with user priority 0, the highest level of priority.

The following packets are tagged with user priority 0 in their 802.1P header:

- PPPoE packets
 - PPPoE Active Discovery Offer (PADO)
 - PPPoE Active Discovery Session Confirmation (PADS)

- PPP packets
 - Link Control Protocol (LCP)
 - Network Control Protocol (NCP) (Internet Protocol Control Protocol (IPCP))
 - Authentication
 - Keepalive

How to Configure 802.1P CoS Bit Set for PPP and PPPoE Control Frames

The 802.1P CoS Bit Set for PPP and PPPoE Control Frames feature is enabled by default and requires no configuration.

Configuration Examples for 802.1P CoS Bit Set for PPP and PPPoE Control Frames

The following task explains how to change the CoS setting for PPP and PPPoE control frames over 802.1Q VLAN.

Setting 802.1P Priority Bits in 802.1Q Frames Containing PPPoE Control Packets

This task explains how to change the CoS settings for PPP and PPPoE control frames over 802.1Q VLAN.

SUMMARY STEPS

1. `enable`
2. `configure terminal`
3. `bba-group pppoe group-name`
4. `control-packets vlan cos priority`
5. `exit`
6. `bba-group pppoe group-name`
7. `control-packets vlan cos priority`
8. `exit`

DETAILED STEPS

	Command or Action	Purpose
Step 1	<code>enable</code>	Enables privileged EXEC mode.

	Command or Action	Purpose
	Example: <pre>Router> enable</pre>	<ul style="list-style-type: none"> • Enter your password if prompted.
Step 2	configure terminal Example: <pre>Router# configure terminal</pre>	Enters global configuration mode.
Step 3	bba-group pppoe group-name Example: <pre>Router(config)# bba-group pppoe global</pre>	Specifies the BBA group and enters BBA group configuration mode.
Step 4	control-packets vlan cos priority Example: <pre>Router(config-bba-group)# control-packets vlan cos 5</pre>	Sets the PPPoE control packets associated with the BBA group.
Step 5	exit Example: <pre>Router(config-bba-group)# exit</pre>	Exits BBA group configuration mode, and returns to global configuration mode.
Step 6	bba-group pppoe group-name Example: <pre>Router(config)# bba-group pppoe cisco</pre>	Specifies the BBA group cisco and enters BBA group configuration mode.
Step 7	control-packets vlan cos priority Example: <pre>Router(config-bba-group)# control-packets vlan cos 2</pre>	Sets the PPPoE control packets associated with the BBA group.
Step 8	exit Example: <pre>Router(config-bba-group)# exit</pre>	Exits BBA group configuration mode, and returns to global configuration mode.

Additional References

The following sections provide references related to the 802.1P CoS Bit Set for PPP and PPPoE Control Frames feature.

Related Documents

Related Topic	Document Title
Broadband access aggregation concepts	<i>Cisco IOS XE Broadband and DSL Configuration Guide</i>
Broadband access commands	<i>Cisco IOS Broadband Access Aggregation and DSL Command Reference</i>

Standards

Standard	Title
IEEE Standard 802.1P	PPPoE over IEEE 802.1Q
IEEE Standard 802.1Q	Virtual Bridged Local Area Networks

MIBs

MIB	MIBs Link
No new or modified MIBs are supported by this feature, and support for existing MIBs has not been modified by this feature.	To locate and download MIBs for selected platforms, Cisco IOS XE software releases, and feature sets, use Cisco MIB Locator found at the following URL: http://www.cisco.com/go/mibs

RFCs

RFC	Title
RFC 2516	PPP over Ethernet

Technical Assistance

Description	Link
<p>The Cisco Support website provides extensive online resources, including documentation and tools for troubleshooting and resolving technical issues with Cisco products and technologies.</p> <p>To receive security and technical information about your products, you can subscribe to various services, such as the Product Alert Tool (accessed from Field Notices), the Cisco Technical Services Newsletter, and Really Simple Syndication (RSS) Feeds.</p> <p>Access to most tools on the Cisco Support website requires a Cisco.com user ID and password.</p>	<p>http://www.cisco.com/techsupport</p>

Feature Information for 802.1P CoS Bit Set for PPP and PPPoE Control Frames

The following table provides release information about the feature or features described in this module. This table lists only the software release that introduced support for a given feature in a given software release train. Unless noted otherwise, subsequent releases of that software release train also support that feature.

Use Cisco Feature Navigator to find information about platform support and Cisco software image support. To access Cisco Feature Navigator, go to www.cisco.com/go/cfn. An account on Cisco.com is not required.

Table 25: Feature Information for 802.1P CoS Bit Set for PPP and PPPoE Control Frames

Feature Name	Releases	Feature Information
802.1P CoS Bit Set for PPP and PPPoE Control Frames	Cisco IOS XE Release 2.4	<p>The 802.1P CoS Bit Set for PPP and PPPoE Control Frames feature provides the ability to set user priority bits in the IEEE 802.1Q tagged frame to allow traffic prioritization. This capability enables a way to provide best-effort QoS or CoS at Layer 2 without requiring reservation setup.</p> <p>In Cisco IOS XE Release 2.4, this feature was introduced.</p> <p>The following command was introduced: control-packets vlan cos.</p>



PPP over Ethernet Client

The PPP over Ethernet Client feature provides PPP over Ethernet (PPPoE) client support on routers.

PPPoE is a commonly used application in the deployment of digital subscriber lines (DSLs). The PPP over Ethernet Client feature expands PPPoE functionality by providing support for PPPoE on the client and the server.

- [Finding Feature Information, page 221](#)
- [Prerequisites for PPP over Ethernet Client, page 221](#)
- [Restrictions for PPP over Ethernet Client, page 222](#)
- [Information About PPP over Ethernet Client, page 222](#)
- [How to Configure PPP over Ethernet Client, page 225](#)
- [Configuration Examples for the PPP over Ethernet Client, page 233](#)
- [Additional References, page 239](#)
- [Feature Information for PPP over Ethernet Client, page 240](#)

Finding Feature Information

Your software release may not support all the features documented in this module. For the latest caveats and feature information, see [Bug Search Tool](#) and the release notes for your platform and software release. To find information about the features documented in this module, and to see a list of the releases in which each feature is supported, see the feature information table.

Use Cisco Feature Navigator to find information about platform support and Cisco software image support. To access Cisco Feature Navigator, go to www.cisco.com/go/cfn. An account on Cisco.com is not required.

Prerequisites for PPP over Ethernet Client

PPP connections must be established between two endpoints over a serial link.

Restrictions for PPP over Ethernet Client

The PPPoE client does not support the following:

- More than ten clients per customer premises equipment (CPE)
- Quality of service (QoS) transmission with queueing on the dialer interface
- Dial-on-demand
- Easy VPN
- Native IPv6
- PPPoE client over ATM permanent virtual circuit (PVC)
- You can configure a dial-pool-number on a physical interface or sub-interface using the **pppoe-client dial-pool-number *pool-number*** command.



Note The pool number being unique cannot be used to configure with the same number on any other interfaces.

- Co-existence of the PPPoE client and server on the same device.
- Multilink PPP (MLP) on dialer interfaces
- Nonstop forwarding (NSF) with stateful switchover (SSO)

Information About PPP over Ethernet Client

PPP over Ethernet Client Network Topology

The PPPoE Client feature provides PPPoE client support on routers at customer premises. Before the introduction of this feature, Cisco IOS XE software supported PPPoE only on the access server side. The

figure below shows Dynamic Multipoint VPN (DMVPN) access to multiple hosts from the same PPPoE client using a common dialer interface and shared IPsec.

Figure 17: DMVPN Access to Multiple Hosts from the Same PPPoE Client

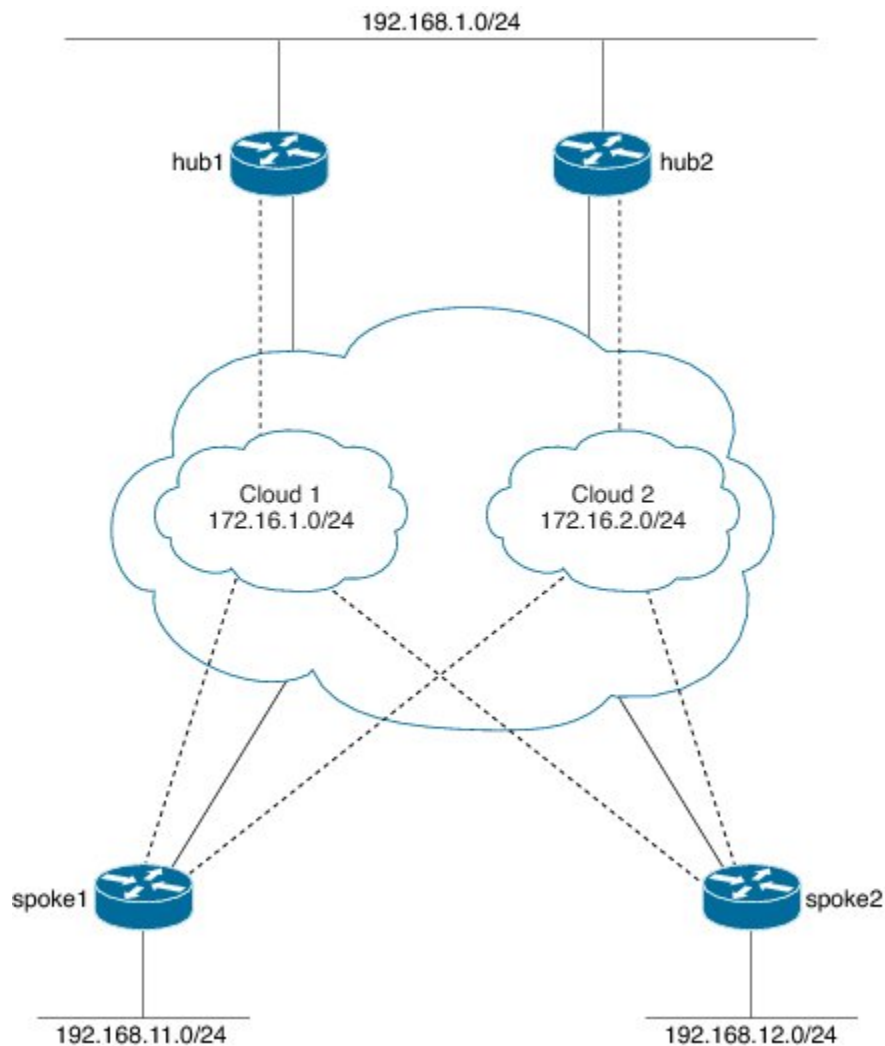

284654

PPP over Ethernet Client Session Initiation

A PPPoE session is initiated by the PPPoE client. If the session has a timeout or is disconnected, the PPPoE client will immediately attempt to reestablish the session.

The following steps describe the exchange of packets that occurs when a PPPoE client initiates a PPPoE session:

- 1 The client broadcasts a PPPoE active discovery initiation (PADI) packet.
- 2 When the access concentrator receives a PADI packet that it can serve, it replies by sending a PPPoE active discovery offer (PADO) packet to the client.

- 3 Because the PADI packet was broadcast, the host may receive more than one PADO packet. The host looks through the PADO packets it receives and chooses one. The choice can be based on the access concentrator name or on the services offered. The host then sends a single PPPoE active discovery request (PADR) packet to the access concentrator that it has chosen.
- 4 The access concentrator responds to the PADR packet by sending a PPPoE active discovery session-confirmation (PADS) packet. At this point, a virtual access interface is created that will then negotiate PPP and the PPPoE session will run on this virtual access.

If a client does not receive a PADO packet for a PADI packet already received, the client sends out a PADI packet at predetermined intervals. That interval length is doubled for every successive PADI packet that does not evoke a response, until the interval reaches the configured maximum.

If PPP negotiation fails or the PPP line protocol is brought down for any reason, the PPPoE session and the virtual access will be brought down and the client will wait for a predetermined number of seconds before trying to establish another PPPoE session.

How to Configure PPP over Ethernet Client

Configuring a PPPoE Client

SUMMARY STEPS

1. **enable**
2. **configure terminal**
3. **interface** *type number*
4. **no ip address**
5. **pppoe enable group global**
6. **pppoe-client dial-pool-number** *number*
7. **no shutdown**
8. **exit**
9. **interface dialer** *number*
10. **dialer** *pool number*
11. **encapsulation** *type*
12. **ipv6 enable**
13. Do one of the following:
 - **ip address negotiated**
 - **ipv6 address autoconfig**
 - **ipv6 dhcp client pd** *prefix-name*
14. **mtu** *size*
15. **ppp authentication pap callin**
16. **ppp pap sent-username** *username* **password** *password*
17. **end**

DETAILED STEPS

	Command or Action	Purpose
Step 1	enable Example: Device> enable	Enables privileged EXEC mode. <ul style="list-style-type: none"> • Enter your password if prompted.
Step 2	configure terminal Example: Device# configure terminal	Enters global configuration mode.

	Command or Action	Purpose
Step 3	interface <i>type number</i> Example: Device(config)# interface GigabitEthernet 0/0/0	Configures an interface and enters interface configuration mode.
Step 4	no ip address Example: Device(config-if)# no ip address	Removes the IP address.
Step 5	pppoe enable group global Example: Device(config-if)# pppoe enable group global	Enables a PPPoE session on the Gigabit Ethernet interface.
Step 6	pppoe-client dial-pool-number <i>number</i> Example: Device(config-if)# pppoe-client dial-pool-number 1	Configures a PPPoE client and specifies dial-on-demand routing (DDR) functionality.
Step 7	no shutdown Example: Device(config-if)# no shutdown	Removes the IP address.
Step 8	exit Example: Device(config-if)# exit	Exits interface configuration mode and returns to global configuration mode.
Step 9	interface dialer <i>number</i> Example: Device(config)# interface dialer 1	Defines a dialer rotary group and enters interface configuration mode.
Step 10	dialer pool <i>number</i> Example: Device(config-if)# dialer pool 1	Specifies the dialing pool that the dialer interface uses to connect to a specific destination subnetwork.
Step 11	encapsulation <i>type</i> Example: Device(config-if)# encapsulation ppp	Specifies the encapsulation type. <ul style="list-style-type: none"> • Sets PPP as the encapsulation type.
Step 12	ipv6 enable Example: Device(config-if)# ipv6 enable	Enables IPv6 on the dialer interface.

	Command or Action	Purpose
Step 13	<p>Do one of the following:</p> <ul style="list-style-type: none"> • ip address negotiated • ipv6 address autoconfig • ipv6 dhcp client pd <i>prefix-name</i> <p>Example: For IPv4 Device(config-if)# ip address negotiated</p> <p>Example: For IPv6 Device(config-if)# ipv6 address autoconfig</p> <p>Example: For DHCP IPv6 Device(config-if)# ipv6 dhcp client pd pd1</p>	<p>Specifies how the IP address is obtained for the dialer interface. This can be through one of the following as specified:</p> <ul style="list-style-type: none"> • PPP/IP Control Protocol (IPCP) address negotiation • Dynamic Host Configuration Protocol (DHCP)
Step 14	<p>mtu <i>size</i></p> <p>Example: Device(config-if)# mtu 1492</p>	Sets the maximum transmission unit (MTU) size.
Step 15	<p>ppp authentication pap callin</p> <p>Example: Device(config-if)# ppp authentication pap callin</p>	Enables at least one PPP authentication protocol and specifies the order in which protocols are selected on the interface.
Step 16	<p>ppp pap sent-username <i>username</i> password <i>password</i></p> <p>Example: Device(config-if)# ppp pap sent-username username1 password password1</p>	Reenables remote Password Authentication Protocol (PAP) support for an interface and reuses the username and password parameters in the PAP authentication packet to the peer.
Step 17	<p>end</p> <p>Example: Device(config-if)# end</p>	Exits interface configuration mode and returns to privileged EXEC mode.

Configuring PPPoE on the Server

SUMMARY STEPS

1. **enable**
2. **configure terminal**
3. **username** *username* **password** *password*
4. **bba-group pppoe** *bba-group-name*
5. **virtual-template** *template-number*
6. **exit**
7. **interface loopback** *interface-number*
8. Do one of the following:
 - **ip address** *ip-address* *mask*
 - **ipv6 address** *ipv6-address* */prefix*
9. **exit**
10. **interface** *type number*
11. Do one of the following:
 - **no ip address**
 - **no ipv6 address**
12. **pppoe enable group** *bba-group-name*
13. **exit**
14. **interface virtual-template** *number*
15. Do one of the following:
 - **ip unnumbered loopback** *number*
 - **ipv6 unnumbered loopback** *number*
16. **description** *description*
17. **mtu** *size*
18. Do one of the following:
 - **peer default ip address pool** *local-pool-name*
 - **peer default ipv6 address pool** *local-pool-name*
 - **ipv6 dhcp server** *dhcp-pool-name*
19. **ppp authentication** *protocol*
20. **exit**
21. **ipv6 dhcp pool** *dhcp-pool-name*
22. **prefix-delegation pool** *local-pool-name*
23. Do one of the following:
 - **ip local pool** *pool-name* [*low-ip-address* [*high-ip-address*]]

- **ipv6 local pool** *pool-name ipv6-subnet-id /prefix prefix-length*

24. end

DETAILED STEPS

	Command or Action	Purpose
Step 1	enable Example: Device> enable	Enables privileged EXEC mode. <ul style="list-style-type: none"> • Enter your password if prompted.
Step 2	configure terminal Example: Device# configure terminal	Enters global configuration mode.
Step 3	username <i>username password password</i> Example: Device(config)# username username1 password password1	Creates a PPPoE profile and enters BBA group configuration mode.
Step 4	bba-group pppoe <i>bba-group-name</i> Example: Device(config)# bba-group pppoe bba1	Creates a PPPoE profile and enters BBA group configuration mode.
Step 5	virtual-template <i>template-number</i> Example: Device(config-bba-group)# virtual-template 1	Creates a virtual template for a PPPoE profile with an identifying number to be used for cloning virtual access interfaces. <ul style="list-style-type: none"> • The range is 1 to 4095.
Step 6	exit Example: Device(config-bba-group)# exit	Exits BBA group configuration mode and returns to global configuration mode.
Step 7	interface loopback <i>interface-number</i> Example: Device(config)# interface loopback 1	Creates a loopback interface that emulates an interface that is always up and enters interface configuration mode. <ul style="list-style-type: none"> • The range is from 0 to 2147483647.
Step 8	Do one of the following: <ul style="list-style-type: none"> • ip address <i>ip-address mask</i> • ipv6 address <i>ipv6-address /prefix</i> 	Assigns an IP address to the loopback interface.

	Command or Action	Purpose
	<p>Example: Using an IPv4 address: Device(config-if)# ip address 192.2.0.2 255.255.255.0</p> <p>Example: Using an IPv6 address: Device(config-if)# ipv6 address 2001:DB8:2::1/40</p>	
Step 9	<p>exit</p> <p>Example: Device(config-if)# exit</p>	Exits interface configuration mode and enters global configuration mode.
Step 10	<p>interface <i>type number</i></p> <p>Example: Device(config)# interface GigabitEthernet 0/0/0</p>	Configures an interface and enters interface configuration mode.
Step 11	<p>Do one of the following:</p> <ul style="list-style-type: none"> • no ip address • no ipv6 address <p>Example: For an IPv4 address: Device(config-if)# no ip address</p> <p>Example: For an IPv6 address: Device(config-if)# no ipv6 address</p>	Removes the IP address.
Step 12	<p>pppoe enable group <i>bba-group-name</i></p> <p>Example: Device(config-if)# pppoe enable group bba1</p>	Enables PPPoE sessions on the Gigabit Ethernet interface.
Step 13	<p>exit</p> <p>Example: Device(config-if)# exit</p>	Exits interface configuration mode and returns to global configuration mode.
Step 14	<p>interface virtual-template <i>number</i></p> <p>Example: Device(config)# interface virtual-template 1</p>	Creates a virtual template interface that can be configured and applied dynamically to create virtual access interfaces and enters interface configuration mode.

	Command or Action	Purpose
Step 15	<p>Do one of the following:</p> <ul style="list-style-type: none"> • ip unnumbered loopback <i>number</i> • ipv6 unnumbered loopback <i>number</i> <p>Example: For IPv4: Device(config-if)# ip unnumbered loopback 1</p> <p>Example: For IPv6: Device(config-if)# ipv6 unnumbered loopback 1</p>	<p>Enables IP processing on an interface without explicitly assigning an IP address to the interface.</p> <ul style="list-style-type: none"> • The <i>type</i> argument is the interface on which the router has assigned an IP address. • The <i>number</i> argument is the number of the interface on which you want to enable IP processing.
Step 16	<p>description <i>description</i></p> <p>Example: Device(config-if)# description pppoe bba1</p>	<p>Adds a description to an interface configuration</p>
Step 17	<p>mtu <i>size</i></p> <p>Example: Device(config-if)# mtu 1492</p>	<p>Sets the MTU size.</p> <ul style="list-style-type: none"> • The range is from 64 to 9216.
Step 18	<p>Do one of the following:</p> <ul style="list-style-type: none"> • peer default ip address pool <i>local-pool-name</i> • peer default ipv6 address pool <i>local-pool-name</i> • ipv6 dhcp server <i>dhcp-pool-name</i> <p>Example: For IPv4 addresses Device(config-if)# peer default ip address pool pool1</p> <p>Example: For IPv6 addresses Device(config-if)# peer default ipv6 address pool pool1</p> <p>Example: For DHCP assigned addresses: Device(config-if)# ipv6 dhcp server dhcpv6pool</p>	<p>Specifies an address pool to provide IP addresses for remote peers connecting to this interface.</p>
Step 19	<p>ppp authentication <i>protocol</i></p> <p>Example: Device(config-if)# ppp authentication pap</p>	<p>Enables at least one PPP authentication protocol and specifies the order in which the protocols are selected on the interface.</p>

	Command or Action	Purpose
Step 20	exit Example: Device(config-if)# exit	Exits interface configuration mode and returns to global configuration mode.
Step 21	ipv6 dhcp pool <i>dhcp-pool-name</i> Example: Device(config)# ipv6 dhcp pool dhcpv6pool	Creates a DHCP information pool and configures a local prefix pool from which prefixes can be delegated to clients.
Step 22	prefix-delegation pool <i>local-pool-name</i> Example: Device(config-dhcpv6)# prefix-delegation pool pool1	Specifies a local prefix pool.
Step 23	Do one of the following: <ul style="list-style-type: none"> • ip local pool <i>pool-name</i> [<i>low-ip-address</i> [<i>high-ip-address</i>]] • ipv6 local pool <i>pool-name</i> <i>ipv6-subnet-id</i> /<i>prefix</i> <i>prefix-length</i> Example: For IPv4 addresses Device(config)# ip local pool pool1 192.2.0.1 192.2.0.10 Example: For IPv6 addresses Device(config)# ipv6 local pool pool1 2001:DB8:1200::/40 48	Configures a local pool of IP addresses to be used when a remote peer connects to a point-to-point interface.
Step 24	end Example: Device(config)# end	Exits global configuration mode and returns to privileged EXEC mode.

Configuration Examples for the PPP over Ethernet Client

Example: Configuring a PPPoE Client

```
Device> enable
Device# configure terminal
Device(config)# interface GigabitEthernet 0/0/0
Device(config-if)# no ip address
```

```

Device(config-if)# pppoe enable
Device(config-if)# pppoe-client dial-pool-number 1
Device(config-if)# no shutdown
Device(config-if)# exit
Device(config)# interface dialer 1
Device(config-if)# mtu 1492
Device(config-if)# ip address negotiated
Device(config-if)# encapsulation ppp
Device(config-if)# dialer pool 1
Device(config-if)# ppp pap sent-username username1 password password1
Device(config-if)# end

```

Example: Configuring PPPoE on IPv4

Example: Server Configuration

```

Device> enable
Device# configure terminal
Device# username username1 password password1
Device(config)# bba-group pppoe bbal
Device(config-bba-group)# virtual-template 1
Device(config-bba-group)# exit
Device(config)# interface loopback 1
Device(config-if)# ip address 192.2.0.2 255.255.255.0
Device(config-if)# exit
Device(config)# interface GigabitEthernet 0/0/0
Device(config-if)# no ip address
Device(config-if)# negotiation auto
Device(config-if)# pppoe enable group bbal
Device(config-if)# no shutdown
Device(config-if)# exit
Device(config)# interface virtual-template 1
Device(config-if)# description pppoe bbal
Device(config-if)# mtu 1492
Device(config-if)# ip unnumbered loopback 1
Device(config-if)# peer default ip address pool pool1
Device(config-if)# ppp authentication pap
Device(config-if)# exit
Device(config)# ip local pool pool1 192.2.0.1 192.2.0.10
Device(config)# end

```

Example: Client Configuration

```

Device> enable
Device# configure terminal
Device(config)# interface GigabitEthernet 0/0/0
Device(config-if)# no ip address
Device(config-if)# pppoe enable
Device(config-if)# pppoe-client dial-pool-number 1
Device(config-if)# no shutdown
Device(config-if)# exit
Device(config)# interface dialer 1
Device(config-if)# mtu 1492
Device(config-if)# ip address negotiated
Device(config-if)# encapsulation ppp
Device(config-if)# dialer pool 1
Device(config-if)# ppp pap sent-username username1 password password1
Device(config-if)# end

```

Example: Configuring PPPoE on IPv6 using DHCP

Example: Server Configuration using DHCP

Configure a username and a password for PPP client:

```
Host(config)# username username1 password password1
```

Create a PPP group GROUPA and associate it with a Virtual Template 1:

```
Host(config)# bba-group pppoe GROUPA
Host(config-bba-group)# virtual-template 1
Host(config-bba-group)# exit
```

Configure a loopback interface to be used on the Virtual Template 1:

```
Host(config)# interface loopback 1
Host(config-if)# ipv6 address 2001:DB8:2::1/40
```

```
%LINEPROTO-5-UPDOWN: Line protocol on Interface Loopback0, changed state to up
```

```
Host(config-if)# exit
```

Create a Virtual Template 1 and use the loopback interface as the IP address:

```
Host(config)# interface virtual-template 1
Host(config-if)# ipv6 unnumbered loopback 1
Host(config-if)# description pppoe GROUPA
Host(config-if)# mtu 1492
```

```
!Specify that PPP PAP authentication is used for authenticating connecting PPP
!clients
```

```
Host(config-if)# ppp authentication pap
```

```
!Enables DHCP for IPv6 service for the interface and specifies a pool for prefix
!delegation.
```

```
Host(config-if)# ipv6 dhcp server dhcpv6pool
```

```
Host(config-dhcp)# exit
```

Associate a physical interface with the PPP group GROUPA:

```
Host(config)# interface FastEthernet 0/0
Host(config-if)# no ip address
Host(config-if)# pppoe enable group GROUPA
Host(config-if)# no shutdown
Host(config-if)# exit
```

Create the local IPV6 address pool pool1 referred to in the Virtual Template 1

```
Host(config)# ipv6 local pool pool1 2001:DB8:1200::/40 48
```

Create a DHCP information pool and configure a local prefix pool from which prefixes can be delegated to clients.

```
Host(config)# ipv6 dhcp pool dhcpv6pool
```

```
!Specify local prefix pool
```

```
Host(config-dhcpv6)# prefix-delegation pool pool1
```

```
Host(config-dhcpv6)# end
```

Example: Client Configuration using DHCP

```
Device> enable
Device# configure terminal
Device(config)# hostname Client
```

Configure a physical interface and allocate it to a dialer pool. A logical dialer interface associated with the dialer pool can select a physical interface from this dialer pool when needed.

```
Client(config)# interface FastEthernet 0/0
Client(config-if)# no ip address
```

Example: Configuring PPPoE on IPv6 using DHCP

```

Client(config-if)# pppoe enable group global

!Allocate the physical interface to the dialer pool
Client(config-if)# pppoe-client dial-pool-number 1
Client(config-if)# no shutdown

%LINK-3-UPDOWN: Interface Virtual-Access1, changed state to up
%LINEPROTO-5-UPDOWN: Line protocol on Interface Virtual-Access1, changed state to up
%LINK-3-UPDOWN: Interface FastEthernet0/0, changed state to up
Client(config-if)# exit
Create the logical dialer interface and configure the pool used to pick physical interfaces
Client(config)# interface dialer 1

!Configure the pool used to pick physical interfaces.
Client(config-if)# dialer pool 1

!Sets the encapsulation method used by the interface to PPP.
Client(config-if)# encapsulation ppp
Client(config-if)# ipv6 enable

*Jun  2 23:51:36.455: %DIALER-6-BIND: Interface Vi2 bound to profile Di1
*Jun  2 23:51:36.459: %LINK-3-UPDOWN: Interface Virtual-Access2, changed state to up
*Jun  2 23:51:36.507: %DIALER-6-UNBIND: Interface Vi2 unbound from profile Di1
*Jun  2 23:51:36.519: %LINK-3-UPDOWN: Interface Virtual-Access2, changed state to down

!Enable Prefix delegation on the interface
Client(config-if)# ipv6 dhcp client pd dhcp_prefix_label

!Reduce MTU of the dialer interface to avoid unnecessary fragmentation caused by added
PPP headers.
Client(config-if)# mtu 1492
Client(config-if)# ppp authentication pap callin

!Configures the username and password that the client can use to authenticate with the
server.
Client(config-if)# ppp pap sent-username username1 password password1

*Jun  2 23:52:20.999: %DIALER-6-BIND: Interface Vi2 bound to profile Di1
*Jun  2 23:52:21.003: %LINK-3-UPDOWN: Interface Virtual-Access2, changed state to up
*Jun  2 23:52:21.103: %LINEPROTO-5-UPDOWN: Line protocol on Interface Virtual-Access2,
changed state to up
Client(config-if)# end

```

Example: Verifying the PPPoE connection

Observe the interfaces of the client:

```

Client#show ipv6 interface brief

FastEthernet0/0          [up/up]
    unassigned
Dialer1                  [up/up]
    FE80::205:FF:FE50:6C08
Virtual-Access1         [up/up]
    unassigned

```

Observe the PPPoE session on the client:

```

Client# show pppoe session

      1 client session

Uniq ID  PPPoE  RemMAC          Port          VT  VA          State
      SID  LocMAC
      N/A    324    0005.0050.9c08  Fa0/0        Di1 Vi2          UP
                        0005.0050.6c08
                        UP

```

Observe the packets exchanged during the PPPoE session:

```
Client# show pppoe session packets
```

```
Total PPPoE sessions 1
```

SID	Pkts-In	Pkts-Out	Bytes-In	Bytes-Out
2846	0	6216	0	128136

Observe the DHCP session:

```
Server# show ipv6 dhcp binding
```

```
Client: FE80::205:FF:FE50:6C08
DUID: 00030001000500506C08
Username : unassigned
Interface : Virtual-Access1.1
IA PD: IA ID 0x000D0001, T1 302400, T2 483840
Prefix: 2001:DB8::/48
        preferred lifetime 604800, valid lifetime 2592000
        expires at Jul 01 2013 09:17 PM (2591979 seconds)
```

```
Server# show ipv6 dhcp pool
```

```
DHCPv6 pool: dhcpv6pool
Prefix pool: pool1
        preferred lifetime 604800, valid lifetime 2592000
Active clients: 1
```

Example: Configuring PPPoE on IPv6

Configuring PPPoE on the Server

```
Device> enable
Device# configure terminal
Device(config)# hostname Host
Configure a username and a password for PPP client:
```

```
Host# username username1 password password1
```

Create a PPP group GROUPA and associate it with a Virtual Template 1:

```
Host(config)# bba-group pppoe GROUPA
```

```
*Jun 1 21:30:55.587: %LINK-3-UPDOWN: Interface Virtual-Access1, changed state to up
*Jun 1 21:30:55.591: %LINEPROTO-5-UPDOWN: Line protocol on Interface Virtual-Access1,
changed state to up
```

```
Host(config-bba-group)# virtual-template 1
```

```
Host(config-bba-group)# exit
```

Configure a loopback interface to be used on the Virtual Template 1:

```
Host(config)# interface loopback 1
```

```
Host(config-if)# ipv6 address 2001:DB8:2::1/40
```

```
%LINEPROTO-5-UPDOWN: Line protocol on Interface Loopback0, changed state to up
```

```
Host(config-if)# exit
```

Create a Virtual Template 1 and use the loopback interface as the IP address:

```
Host(config)# interface virtual-template 1
```

```
Host(config-if)# ipv6 unnumbered loopback 1
```

```
Host(config-if)# description pppoe GROUPA
```

```
Host(config-if)# mtu 1492
```

```
!Configure the Virtual Template to hand out IP addresses from pool1
```

```
Host(config-if)# peer default ipv6 pool pool1
```

```
!Specify that PPP PAP authentication is used for authenticating connecting PPP clients
```

```
Host(config-if)# ppp authentication pap
```

```
Host(config-if)# exit
```

Associate a physical interface with the PPP group GROUPA:

```
Host(config)# interface FastEthernet 0/0
Host(config-if)# no ip address
Host(config-if)# pppoe enable group GROUPA
Host(config-if)# no shutdown
Host(config-if)# exit

*Jun  1 21:33:07.199: %LINK-3-UPDOWN: Interface FastEthernet0/0, changed state to up
*Jun  1 21:33:08.199: %LINEPROTO-5-UPDOWN: Line protocol on Interface FastEthernet0/0,
changed state to up
```

Create the IPV6 address pool pool1 referred to in the Virtual Template 1:

```
Host(config)# ipv6 local pool pool1 2001:DB8:1200::/40 48
Host(config)# end
```

Configuring PPPoE on the Client

```
Device> enable
Device# configure terminal
Device(config)# hostname Host
```

Configure a physical interface and allocate it to a dialer pool. A logical dialer interface associated with the dialer pool can select a physical interface from this dialer pool when needed.

```
Client(config)# interface FastEthernet 0/0
Client(config-if)# no ip address
Client(config-if)# pppoe enable group global

!Allocate the physical interface to the dialer pool
Client(config-if)# pppoe-client dial-pool-number 1
Client(config-if)# no shutdown

%LINK-3-UPDOWN: Interface Virtual-Access1, changed state to up
%LINEPROTO-5-UPDOWN: Line protocol on Interface Virtual-Access1, changed state to up
%LINK-3-UPDOWN: Interface FastEthernet0/0, changed state to up
Client(config-if)# exit
```

Create the logical dialer interface and configure the pool used to pick physical interfaces

```
Client(config)# interface dialer 1

!Configure the pool used to pick physical interfaces.
Client(config-if)# dialer pool 1

!Sets the encapsulation method used by the interface to PPP.
Client(config-if)# encapsulation ppp
Client(config-if)# ipv6 enable

*Jun  3 00:10:48.031: %DIALER-6-BIND: Interface Vi2 bound to profile Di1
*Jun  3 00:10:48.035: %LINK-3-UPDOWN: Interface Virtual-Access2, changed state to up
*Jun  3 00:10:48.083: %DIALER-6-UNBIND: Interface Vi2 unbound from profile Di1
*Jun  3 00:10:48.091: %LINK-3-UPDOWN: Interface Virtual-Access2, changed state to down

!Configure the PPP clients to get IP addresses for dialer interfaces by using
!PPP negotiations with the server.
Client(config-if)# ipv6 address autoconfig

!Reduce MTU of the dialer interface to avoid unnecessary fragmentation caused by added PPP
!headers
Client(config-if)# mtu 1492
Client(config-if)# ppp authentication pap callin

!Configures the username and password that the client can use to authenticate with the
!server.
Client(config-if)# ppp pap sent-username username1 password password1

*Jun  3 00:11:54.843: %DIALER-6-BIND: Interface Vi2 bound to profile Di1
*Jun  3 00:11:54.847: %LINK-3-UPDOWN: Interface Virtual-Access2, changed
```

```

state to up
*Jun  3 00:11:54.939: %LINEPROTO-5-UPDOWN: Line protocol on Interface
Virtual-Access2, changed state to up

Client(config-if)# end

```

Verifying the PPPoE connection

Observe the interfaces of the client:

```

Client# show ipv6 interface brief

FastEthernet0/0          [up/up]
    unassigned
Dialer1                  [up/up]
    FE80::205:FF:FE50:6C08
Virtual-Access1         [up/up]
    unassigned

```

Observe the PPPoE session on the client:

```

Client# show pppoe session

      1 client session

Uniq ID  PPPoE  RemMAC          Port          VT  VA          State
      SID  LocMAC
      N/A   324  0005.0050.9c08  Fa0/0        Di1 Vi2          UP
      0005.0050.6c08
      UP

```

Observe the packets exchanged during the PPPoE session:

```

Client# show pppoe session packets

Total PPPoE sessions 1

SID      Pkts-In      Pkts-Out      Bytes-In      Bytes-Out
2846    0             6216          0             128136

```

Additional References

Related Documents

Related Topic	Document Title
Cisco IOS commands	Cisco IOS Master Commands List, All Releases
Broadband Access Aggregation and DSL commands	Cisco IOS Broadband Access Aggregation and DSL Command Reference

Technical Assistance

Description	Link
The Cisco Support and Documentation website provides online resources to download documentation, software, and tools. Use these resources to install and configure the software and to troubleshoot and resolve technical issues with Cisco products and technologies. Access to most tools on the Cisco Support and Documentation website requires a Cisco.com user ID and password.	http://www.cisco.com/cisco/web/support/index.html

Feature Information for PPP over Ethernet Client

The following table provides release information about the feature or features described in this module. This table lists only the software release that introduced support for a given feature in a given software release train. Unless noted otherwise, subsequent releases of that software release train also support that feature.

Use Cisco Feature Navigator to find information about platform support and Cisco software image support. To access Cisco Feature Navigator, go to www.cisco.com/go/cfn. An account on Cisco.com is not required.

Table 26: Feature Information for PPP over Ethernet Client

Feature Name	Releases	Feature Information
PPP over Ethernet Client for IPv6	Cisco IOS XE Release 3.9S	The PPP over Ethernet Client feature provides IPv6 support.
PPP over Ethernet Client	Cisco IOS XE Release 3.5S	This feature was introduced. The PPP over Ethernet Client feature provides PPPoE client support on routers.



VRF Awareness Access Class Line

The VRF Awareness Access Class Line feature supports access-class command on the VTY line for IPv4 and IPv6.

- [Feature Information for VRF Awareness Access Class Line, page 241](#)
- [Restrictions for VRF Awareness Access-Class Line, page 242](#)
- [Information About VRF Awareness Access Class Line, page 242](#)
- [How to Configure VRF Awareness Access Class Line, page 242](#)
- [Configuration Examples for VRF Awareness Access Class Line, page 243](#)
- [Additional References for VRF Awareness Access Class Line, page 243](#)

Feature Information for VRF Awareness Access Class Line

The following table provides release information about the feature or features described in this module. This table lists only the software release that introduced support for a given feature in a given software release train. Unless noted otherwise, subsequent releases of that software release train also support that feature.

Use Cisco Feature Navigator to find information about platform support and Cisco software image support. To access Cisco Feature Navigator, go to www.cisco.com/go/cfn. An account on Cisco.com is not required.

Table 27: Feature Information for VRF Awareness Access Class Line

Feature Name	Releases	Feature Information
VRF Awareness Access Class Line	Cisco IOS XE Release 16.8.1	<p>The VRF Awareness Access Class Line feature supports access-class command on the VTY line for IPv4 and IPv6.</p> <p>The following commands were introduced or modified by this feature: access-class acl-name in vrfname vrf, ipv6 access-class acl-name in vrfname vrf.</p>

Restrictions for VRF Awareness Access-Class Line

- The **vrf-also** keyword is mutually exclusive of **access-class line** command.
- Multiple VRFs cannot be configured on a single **access-class line** command. For example:

```
line vty 0 4
access-class acl1 in vrfA vrfB vrfC >>>is not supported
```
- When the **vrf aware access-class line** command for the same VRF is re-configured, the last configuration replaces the earlier one.
- If the **access-class line** command is configured with multiple VRFs (for example, vrfA, vrfB, vrfC) on a VTY line and the traffic passes through a different VRF (for example, vrfD), then the packets are dropped.
- There is only one vrf aware **access-class line** command for one VRF. For example:

```
Line vty 0 4
Access-class acl-1 in vrfname vrfA
Access-class acl-2 in vrfname vrfB
Access-class acl-1 in vrfname vrfC
```

Information About VRF Awareness Access Class Line

VRF Awareness Access Class Line

You can control the accessibility of the virtual terminal lines (VTY) to a device by applying an access list to inbound VTYS. You can also control the destinations that the VTYS from a device can reach by applying an access list to outbound VTYS.



Note

When you apply an access list to a VTY using the **access-class** command, the access list can be a numbered access list or a named access list.

How to Configure VRF Awareness Access Class Line

Configure Access-Class on the VTY line

To configure the **access-class** command on the VTY line for IPv6, identify a specific line for configuration. Enter the line command with the optional line type VTY, which is the line number.

```
Device(config)# line vty 0 4
Device(config-line)# ipv6 access-class acl-name in vrfname vrfA
```

**Note**

You also can use the **line** command without specifying a line type. In this case, the line number is treated as an absolute line number.

Configure Multiple Routing Tables or VRFs using Access-Class

To configure multiple routing tables or VRFs:

```
Device(config)# line vty 0 4
Device(config-line)# ipv6 access-class acl-1 in vrf vrfA
Device(config-line)# ipv6 access-class acl-2 in vrf vrfB
Device(config-line)# ipv6 access-class acl-1 in vrf vrfC
```

Configuration Examples for VRF Awareness Access Class Line

Example: VRF Awareness Access-Class for IPv4 and IPv6

```
line vty 0 4
access-class acl-1 in vrfname vrfA
line vty 0 5
ipv6 access-class acl-1 in vrfname MGMT
ipv6 access-class acl-2 in vrfname LOOP
```

Additional References for VRF Awareness Access Class Line

Related Documents

Related Topic	Document Title
Cisco IOS commands	Cisco IOS Master Commands List, All Releases

MIBs

MIB	MIBs Link
• CISCO-MIB	To locate and download MIBs for selected platforms, Cisco IOS releases, and feature sets, use Cisco MIB Locator found at the following URL: http://www.cisco.com/go/mibs

Technical Assistance

Description	Link
<p>The Cisco Support website provides extensive online resources, including documentation and tools for troubleshooting and resolving technical issues with Cisco products and technologies.</p> <p>To receive security and technical information about your products, you can subscribe to various services, such as the Product Alert Tool (accessed from Field Notices), the Cisco Technical Services Newsletter, and Really Simple Syndication (RSS) Feeds.</p> <p>Access to most tools on the Cisco Support website requires a Cisco.com user ID and password.</p>	<p>http://www.cisco.com/cisco/web/support/index.html</p>



PPPoE Smart Server Selection

The PPPoE Smart Server Selection feature allows service providers to determine which Broadband Remote Access Server (BRAS) a PPP call will terminate on.

The PPPoE Smart Server Selection feature allows you to configure a specific PPP over Ethernet (PPPoE) Active Discovery Offer (PADO) delay for a received PPPoE Active Discovery Initiation (PADI) packet. The PADO delay establishes the order in which the BRASs respond to PADIs by delaying their responses to particular PADIs by various times.

- [Finding Feature Information, page 245](#)
- [Information About PPPoE Smart Server Selection, page 245](#)
- [How to Configure PPPoE Smart Server Selection, page 246](#)
- [Configuration Examples for PPPoE Smart Server Selection, page 252](#)
- [Additional References, page 253](#)
- [Feature Information for PPPoE Smart Server Selection, page 254](#)

Finding Feature Information

Your software release may not support all the features documented in this module. For the latest caveats and feature information, see [Bug Search Tool](#) and the release notes for your platform and software release. To find information about the features documented in this module, and to see a list of the releases in which each feature is supported, see the feature information table.

Use Cisco Feature Navigator to find information about platform support and Cisco software image support. To access Cisco Feature Navigator, go to www.cisco.com/go/cfn. An account on Cisco.com is not required.

Information About PPPoE Smart Server Selection

Benefits of PPPoE Smart Server Selection

PPPoE Smart Server Selection provides the following benefits for the Internet service providers (ISPs):

- Optimize their networks by predicting and isolating PPP calls to terminate on a particular BRAS.
- Establish a priority order among the BRASs by configuring varying degrees of delays in the broadband access (BBA) groups on different BRASs.
- Use circuit ID and remote ID tag matching with strings up to 64 characters in length.
- Use spaces in remote ID, circuit ID, and PPPoE service names.
- Restrict the service advertisements from a BRASs in a PADO message.
- Apply a PADO transmission delay based on circuit ID, remote ID, and service name.
- Do partial matching on service name, remote ID, and circuit ID.

How to Configure PPPoE Smart Server Selection

Configuring BBA Group PADO Delay

Perform this task to allow all calls coming into a defined BBA group on a Broadband Remote Access Server (BRAS) to be treated with the same priority. All incoming sessions for a particular group would have their PADO responses delayed by the configured number of milliseconds.

This task allows Internet Service Providers (ISPs) to establish a priority order among the BRASs by configuring varying degrees of delays in the BBA groups on different BRASs.

SUMMARY STEPS

1. **enable**
2. **configure terminal**
3. **bba-group pppoe** {group-name | global}
4. **pado delay** milliseconds

DETAILED STEPS

	Command or Action	Purpose
Step 1	<p>enable</p> <p>Example:</p> <pre>Device> enable</pre>	<p>Enables privileged EXEC mode.</p> <ul style="list-style-type: none"> • Enter your password if prompted.
Step 2	<p>configure terminal</p> <p>Example:</p> <pre>Device# configure terminal</pre>	<p>Enters global configuration mode.</p>

	Command or Action	Purpose
Step 3	bba-group pppoe { <i>group-name</i> global } Example: Device(config)# bba-group pppoe server-selection	Defines a PPP over Ethernet (PPPoE) profile, and enters BBA group configuration mode. <ul style="list-style-type: none"> The global keyword creates a profile, which serves as the default profile for any PPPoE port that is not assigned a specific profile.
Step 4	pado delay <i>milliseconds</i> Example: Device(config-bba-group)# pado delay 512	Sets the time by which a PADO response is delayed for a BBA group. <p>Note The value assigned for milliseconds should be a multiple of 256. Even though the device allows other values, the Cisco Software rounds the values down to the closest multiple of 256.</p>

Troubleshooting Tips

Use the **debug pppoe** command to troubleshoot the PPPoE session.

Configuring PADO Delay Based on Remote ID or Circuit ID

This task uses the **pppoe server** command to define a list of circuit ID and remote ID tags on a BRAS for a particular BBA group. The **pppoe delay** command is extended to specify delays based on the PPPoE circuit ID or remote ID tag.

All incoming calls are scanned and if the circuit ID or remote ID tags in the PADI match the list on the BRAS, then the PADO response will be delayed by the configured delay time. If there is no delay defined based on the circuit ID or remote ID, the per-PPPoE service delay is sought. If it is not found, the delay for the BBA group PADO is used. If no PPPoE delay is found, the PADO is sent without delay.

If there is no match and a BBA group PADO delay is configured under the same BBA group, then the PADO response is delayed by the configured delay time for that BBA group. If a BBA group PADO delay is not configured, then the PADO response is sent immediately.

With PPPoE smart server selection, you can do a partial match for a configured string by using a circuit ID or remote ID delay configured for the PPPoE server. (*Partial matching* is searching for parts of strings. It is used to search for similar strings.)

Perform this task to define a list of circuit ID and remote ID tags on a BRAS for a particular BBA group and configures the delay associated with the circuit ID and remote ID tags.



Note

The value assigned for milliseconds should be a multiple of 256. Even though the device allows other values, the Cisco Software rounds the values down to the closest multiple of 256.

SUMMARY STEPS

1. **enable**
2. **configure terminal**
3. **bba-group pppoe** {*group-name* | **global**}
4. **pppoe server circuit-id delay** *milliseconds* **string** [**contains**] *circuit-id-string*
5. **pppoe server remote-id delay** *milliseconds* **string** [**contains**] *remote-id-string*
6. **pado delay circuit-id** *milliseconds*
7. **pado delay remote-id** *milliseconds*
8. **pado delay** *milliseconds*
9. **end**

DETAILED STEPS

	Command or Action	Purpose
Step 1	enable Example: Device> enable	Enables privileged EXEC mode. <ul style="list-style-type: none"> • Enter your password if prompted.
Step 2	configure terminal Example: Device# configure terminal	Enters global configuration mode.
Step 3	bba-group pppoe { <i>group-name</i> global } Example: Device(config)# bba-group pppoe server-selection	Defines a PPPoE profile, and enters BBA group configuration mode. <ul style="list-style-type: none"> • The global keyword creates a profile that serves as the default profile for any PPPoE port.
Step 4	pppoe server circuit-id delay <i>milliseconds</i> string [contains] <i>circuit-id-string</i> Example: Device(config-bba-group)# pppoe server circuit-id delay 256 string circuit ATM1/0/0 VC 0/100	(Optional) Specifies the delay to be applied based on the PPPoE tag circuit ID from the client. <ul style="list-style-type: none"> • The contains keyword can find a partial match for this delay statement. • The value for the <i>circuit-id-string</i> argument can contain spaces when enclosed with double quotation marks (for example, "circuit ATM1/0/0 VC 0/100").
Step 5	pppoe server remote-id delay <i>milliseconds</i> string [contains] <i>remote-id-string</i>	(Optional) Specifies the delay to be applied based on the PPPoE tag remote ID from the client.

	Command or Action	Purpose
	<p>Example:</p> <pre>Device(config-bba-group)# pppoe server remote-id delay 512 string XTH-TEST</pre>	<ul style="list-style-type: none"> The contains keyword can find a partial match for this delay statement. The value for the <i>remote-id-string</i> argument can contain spaces when enclosed with double quotation marks (for example, "subscr mac 1111.2222.3333").
Step 6	<p>pado delay circuit-id milliseconds</p> <p>Example:</p> <pre>Device(config-bba-group)# pado delay circuit-id 768</pre>	<p>(Optional) Finds a match based on the PPPoE group circuit ID delay if configured..</p> <ul style="list-style-type: none"> If a circuit ID cannot be matched partially, a delay is applied based on any circuit ID that is present.
Step 7	<p>pado delay remote-id milliseconds</p> <p>Example:</p> <pre>Device(config-bba-group)# pado delay remote-id 256</pre>	<p>(Optional) Finds a match based on the PPPoE group remote ID delay if configured..</p>
Step 8	<p>pado delay milliseconds</p> <p>Example:</p> <pre>Device(config-bba-group)# pado delay 512</pre>	<p>(Optional) Uses the group PADO delay configuration. Sets the time by which a PADO response is delayed for a BBA group.</p> <ul style="list-style-type: none"> The PADO delay value is sought if the PADO delay is not found after several attempts.
Step 9	<p>end</p> <p>Example:</p> <pre>Device(config-bba-group)# end</pre>	<p>Ends the configuration session and returns to privileged EXEC mode.</p>

Troubleshooting Tips

Use the **debug pppoe event** command to verify the smart server PADO delay selection.

Configuring PPPoE Service PADO Delay

Perform this task to specify a delay based on the PPPoE service. A delay is applied to the PADO offering based on the service name match.

SUMMARY STEPS

1. **enable**
2. **configure terminal**
3. **policy-map type service** *polycymap-name*
4. **exit**
5. **bba-group pppoe** [**global** | *profile-name*]
6. **virtual-template** *interface-number*
7. **service profile** *subscriber-profile-name* **refresh** *minutes*
8. **service name match**
9. **pado delay** *milliseconds*
10. **end**

DETAILED STEPS

	Command or Action	Purpose
Step 1	enable Example: Device> enable	Enables privileged EXEC mode. <ul style="list-style-type: none"> • Enter your password if prompted.
Step 2	configure terminal Example: Device# configure terminal	Enters global configuration mode.
Step 3	policy-map type service <i>polycymap-name</i> Example: Device(config)# policy-map type service serv3	Places the device in service policy map configuration mode, and defines the name of service policy map.
Step 4	exit Example: Device(config-service-policymap) # exit	Exits service policy map configuration mode and returns to global configuration mode.
Step 5	bba-group pppoe [global <i>profile-name</i>] Example: Device(config-bba-group) # bba-group pppoe global	Defines a PPPoE profile, and enters BBA group configuration mode. <ul style="list-style-type: none"> • The global keyword creates a profile that serves as the default profile for any PPPoE port.

	Command or Action	Purpose
Step 6	virtual-template <i>interface-number</i> Example: Device(config-bba-group) # virtual-template 20	Specifies the virtual template interface number for the BBA group, and places the device in configuration BBA group mode.
Step 7	service profile <i>subscriber-profile-name</i> refresh <i>minutes</i> Example: Device(config-bba-group) # service profile serv3 refresh 30	Specifies the subscriber profile to be associated with the BBA group, and the refresh interval minutes for the service profile.
Step 8	service name match Example: Device(config-bba-group) # service name match	Matches the requested tag for the PPPoE global group. Note The service name match command must be configured per the PPPoE service delay. The requested service by the client should also be configured on the BRAS to ensure PADO response from the BRAS.
Step 9	pado delay <i>milliseconds</i> Example: Device(config-bba-group) # pado delay 512	(Optional) Uses the group PADO delay configuration. Sets the time by which a PADO response is delayed for a BBA group. <ul style="list-style-type: none"> The PADO delay value is sought if the PADO delay is not found after several attempts. Note The value assigned for milliseconds should be a multiple of 256. Even though the device allows other values, the Cisco Software rounds the values down to the closest multiple of 256.
Step 10	end Example: Device(config-bba-group) # end	Ends the configuration session and returns to privileged EXEC mode.

Troubleshooting Tips

Use the **debug pppoe event** command to verify the service name match and PADO delay for a PPPoE service.

Configuration Examples for PPPoE Smart Server Selection

Configuring BBA Group PADO Delay Example

The following example shows how to configure a BBA group for PADO delay:

```
Device> enable
Device# configure terminal
Device(config)# bba-group pppoe server-selection
Device(config-bba-group)# pado delay 512
Device(config-bba-group)# end
```

Configuring PADO Delay Example

The following example shows how to match the string by using a circuit ID or remote ID delay configured for PPPoE server:

```
Device> enable
Device# configure terminal
Device(config)# bba-group pppoe server-selection
Device(config-bba-group)# pppoe server circuit-id delay 256 string "subscr mac 1111.2222.3333"
Device(config-bba-group)# pado delay circuit-id 512
Device(config-bba-group)# pado delay remote-id 768
Device(config-bba-group)# end
```

The following example shows how to configure PADO delay based on the remote ID or circuit ID:

```
Device> enable
Device# configure terminal
Device(config)# bba-group pppoe server-selection
Device(config-bba-group)# pppoe server remote-id delay 512 string contains TEST
Device(config-bba-group)# pppoe server remote-id delay 256 string XTH
Device(config-bba-group)# pppoe server remote-id delay 768 string contains XTH-TEST
Device(config-bba-group)# end
```

Generally, the first match found in the list is considered for the delay value. If the remote ID in the client PPPoE tag contains XTH-TEST, then the delay value is 512. In this case, the first match succeeds and the configuration never reaches a delay of 768. If the remote ID in the client PPPoE tag contains TH- no, then no match is found.

Configuring PPPoE Service PADO Delay Example

The following example shows how to configure the PADO delay based on the PPPoE service:

```
Device> enable
Device# configure terminal
Device(config)# policy-map type service XTH-services
Device(config-service-policymap)# pppoe service ILoBr delay 768
Device(config-service-policymap)# pppoe service xth-service1 delay 256
Device(config-service-policymap)# pppoe service service-nodelay
Device(config-service-policymap)# exit
Device(config)# bba-group pppoe server-selection
Device(config-bba-group)# virtual-template 1
Device(config-bba-group)# service svc-group
```

```
Device(config-bba-group)# service profile XTH-services
Device(config-bba-group)# service name match
Device(config-bba-group)# pado delay 512
Device(config-bba-group)# end
```

Verifying the PPPoE Service Match and PADO Delay Example

The following example shows the output of the service name match and PADO delay for a PPPoE service using the **show pppoe derived group group-name** command. This command prints all the PPPoE services for the supported groups and also shows the associated delay for this service.

```
Device# show pppoe derived group svc-group

Derived configuration from subscriber profile 'XTH-services':
Service names: servicename:pado-delay
ILoBr:768, xth-service1:256, service nodelay:0
```

Additional References

The following sections provide references related to the PPPoE Smart Server Selection feature.

Related Documents

Related Topic	Document Title
Configuring broadband and DSL	<i>Cisco IOS XE Broadband and DSL Configuration Guide</i>
Additional information about commands used in this document	<ul style="list-style-type: none"> • <i>Cisco IOS Broadband Access Aggregation and DSL Command Reference</i> • Cisco IOS Master Command List, All Releases

Standards

Standard	Title
None	-

MIBs

MIB	MIBs Link
None	To locate and download MIBs for selected platforms, Cisco IOS XE releases, and feature sets, use Cisco MIB Locator found at the following URL: http://www.cisco.com/go/mibs

RFCs

RFC	Title
RFC 2516	<i>A Method for Transmitting PPP over Ethernet (PPPoE)</i>

Technical Assistance

Description	Link
<p>The Cisco Support website provides extensive online resources, including documentation and tools for troubleshooting and resolving technical issues with Cisco products and technologies.</p> <p>To receive security and technical information about your products, you can subscribe to various services, such as the Product Alert Tool (accessed from Field Notices), the Cisco Technical Services Newsletter, and Really Simple Syndication (RSS) Feeds.</p> <p>Access to most tools on the Cisco Support website requires a Cisco.com user ID and password.</p>	http://www.cisco.com/techsupport

Feature Information for PPPoE Smart Server Selection

The following table provides release information about the feature or features described in this module. This table lists only the software release that introduced support for a given feature in a given software release train. Unless noted otherwise, subsequent releases of that software release train also support that feature.

Use Cisco Feature Navigator to find information about platform support and Cisco software image support. To access Cisco Feature Navigator, go to www.cisco.com/go/cfn. An account on Cisco.com is not required.

Table 28: Feature Information for PPPoE Smart Server Selection

Feature Name	Releases	Feature Information
PPPoE Smart Server Selection	Cisco IOS XE Release 2.4	PPPoE Smart Server Selection allows service providers to determine which Broadband Remote Access Server (BRAS) a PPP call will terminate on.



Monitoring PPPoE Sessions with SNMP

The PPPoE Session Count Management Information Base feature provides the ability to use Simple Network Management Protocol (SNMP) to monitor in real time the number of PPP over Ethernet (PPPoE) sessions configured on permanent virtual circuits (PVCs) and on a router.

The SNMP Traps for PPPoE Session Limits feature provides SNMP MIB support for the PPPoE session limits and generates notifications in case the limits are reached.

This MIB also supports two SNMP traps that generate notification messages when a PPPoE session-count threshold is reached on any PVC or on the router. The PPPoE session-count thresholds can be configured using the **sessions max limit** and **pppoe max-sessions** commands.

- [Finding Feature Information, page 255](#)
- [Prerequisites for Monitoring PPPoE Sessions with SNMP, page 256](#)
- [Restrictions for Monitoring PPPoE Sessions with SNMP, page 256](#)
- [Information About Monitoring PPPoE Sessions with SNMP, page 256](#)
- [How to Configure Monitoring of PPPoE Sessions with SNMP, page 258](#)
- [Configuration Examples for Monitoring PPPoE Sessions with SNMP, page 269](#)
- [Where to Go Next, page 270](#)
- [Additional References, page 270](#)
- [Feature Information for Monitoring PPPoE Sessions with SNMP, page 272](#)

Finding Feature Information

Your software release may not support all the features documented in this module. For the latest caveats and feature information, see [Bug Search Tool](#) and the release notes for your platform and software release. To find information about the features documented in this module, and to see a list of the releases in which each feature is supported, see the feature information table.

Use Cisco Feature Navigator to find information about platform support and Cisco software image support. To access Cisco Feature Navigator, go to www.cisco.com/go/cfn. An account on Cisco.com is not required.

Prerequisites for Monitoring PPPoE Sessions with SNMP

- You must understand the concepts described in the Preparing for Broadband Access Aggregation module.
- PPPoE sessions must be established using the procedures in the Providing Protocol Support for Broadband Access Aggregation of PPPoE Sessions module.

Restrictions for Monitoring PPPoE Sessions with SNMP

The `snmp-server enable traps pppoe` command enables SNMP traps only. It does not support inform requests.

Information About Monitoring PPPoE Sessions with SNMP

Network Management Protocol

SNMP is a network management protocol used almost exclusively in TCP/IP networks. SNMP provides a means to monitor and control network devices and to manage configurations, statistics collection, performance, and security. SNMP version 2 supports centralized and distributed network management strategies and includes improvements in the Structure of Management Information (SMI), protocol operations, management architecture, and security.

PPPoE Session Count MIB

A MIB is a database of network management information that is used and maintained by a network management protocol, such as SNMP. The value of a MIB object can be changed or retrieved using SNMP commands, usually through a network management system.

The PPPoE Session Count MIB uses two SNMP traps that generate notification messages when a PPPoE session-count threshold is reached on any PVC or on the router. The PPPoE session-count thresholds can be configured using the `sessions max limit` and `pppoe max-sessions` commands. You can also set per-MAC session and IWF limits for a PPPoE session, per-MAC throttle rate limit for a PPPoE session, per-VLAN session configuration limit, per-VLAN throttle rate limit, per-VC session configuration limit, and per-VC throttle rate limit configuration limit.

The table below describes the objects and tables supported by the PPPoE Session-Count MIB. For a complete description of the MIB, see the PPPoE Sessions Management MIB file CISCO-PPPOE-MIB.my, available through Cisco.com at the following URL: <http://tools.cisco.com/ITDIT/MIBS/servlet/index>.

Table 29: PPPoE Session Count MIB Objects and Tables

Object or Table	Description
cPppoeSystemCurrSessions	Number of PPPoE sessions active on the router.

Object or Table	Description
cPppoeSystemHighWaterSessions	Highest number of PPPoE sessions configured at a particular time after the system was initialized.
cPppoeSystemMaxAllowedSessions	Number of PPPoE sessions configurable on the router.
cPppoeSystemThresholdSessions	Threshold value of PPPoE sessions configurable on the router.
cPppoeSystemExceededSessionErrors	Accumulated number of errors on the router that have occurred because the cPppoeSystemCurrSessions value exceeded the cPppoeSystemMaxAllowedSessions value.
cPppoeSystemPerMacSessionlimit	Per-MAC session limit for a PPPoE session
cPppoeSystemPerMacIWFSessionlimit	Per-MAC session IWF limit for a PPPoE session
cPppoeSystemPerMacThrottleRatelimit	Per-MAC throttle rate limit for a PPPoE session
cPppoeSystemPerVLANlimit	Per-VLAN session configuration limit
cPppoeSystemPerVLANthrottleRatelimit	Per-VLAN throttle rate limit
cPppoeSystemPerVCLimit	Per-VC session configuration limit
cPppoeSystemPerVCThrottleRatelimit	Per-VC throttle rate limit configuration limit
cPppoeVcCfgTable	PPPoE protocol-related configuration information about the virtual channel links (VCLs).
cPppoeVcSessionsTable	Configuration information and statistics about the number of PPPoE sessions on the VCLs.
cPppoeSystemSessionThresholdTrap	Generates a notification message when the number of PPPoE sessions on the router reaches the configured threshold value.
cPppoeVcSessionThresholdTrap	Generates a notification message when the number of PPPoE sessions on the PVC reaches the configured threshold value.

Benefits of Monitoring PPPoE Sessions with SNMP

The monitoring of PPPoE sessions with SNMP provides the following benefits:

- It helps manage the number of PPPoE sessions configured on a router or PVC by sending notification messages when the PPPoE session threshold has been reached.

- It provides a way of tracking PPPoE session information over time.

How to Configure Monitoring of PPPoE Sessions with SNMP

Configuring the PPPoE Session-Count Threshold for the Router

Perform this task to configure the PPPoE session-count threshold for the router.



Note

The **sessions max limit** command is available only if you configure the **bba-group pppoe** command using the **global** keyword.

SUMMARY STEPS

1. **enable**
2. **configure terminal**
3. **snmp-server enable traps pppoe**
4. **bba-group pppoe** *{group-name | global}*
5. **sessions max limit** *session-number* [**threshold** *threshold-value*]
6. **virtual-template** *template-number*
7. **end**
8. **more system:running-config**

DETAILED STEPS

	Command or Action	Purpose
Step 1	enable Example: Router> enable	Enables privileged EXEC mode. <ul style="list-style-type: none"> • Enter your password if prompted.
Step 2	configure terminal Example: Router# configure terminal	Enters global configuration mode.
Step 3	snmp-server enable traps pppoe Example: Router(config)# snmp-server enable traps pppoe	(Optional) Enables PPPoE session count SNMP notifications. <ul style="list-style-type: none"> • This command enables SNMP traps that send notification messages when PPPoE sessions have been reached.

	Command or Action	Purpose
Step 4	bba-group pppoe { <i>group-name</i> global } Example: Router(config)# bba-group pppoe global	Configures a BBA group to be used to establish PPPoE sessions and enters BBA group configuration mode.
Step 5	sessions max limit <i>session-number</i> [threshold <i>threshold-value</i>] Example: Router(config-bba-group)# sessions max limit 4000 threshold 3000	Configures the PPPoE global profile with the maximum number of PPPoE sessions permitted on a router and sets the PPPoE session-count threshold at which an SNMP trap will be generated. Note This command applies only to the global profile.
Step 6	virtual-template <i>template-number</i> Example: Router(config-bba-group)# virtual-template 1	Specifies the virtual template that will be used to clone the virtual access interfaces (VAI).
Step 7	end Example: Router(config-bba-group)# end	Exits BBA group configuration mode and returns to privileged EXEC mode.
Step 8	more system:running-config Example: Router(#) more system:running-config	Displays the running configuration and the PPPoE session-count thresholds.

Configuring the PPPoE Session-Count Threshold for a PVC

Perform this task to configure the PPPoE session-count threshold for a PVC.

SUMMARY STEPS

1. **enable**
2. **configure terminal**
3. **snmp-server enable traps pppoe**
4. **interface atm** *slot / subslot / port* [*.subinterface*] [**multipoint** | **point-to-point**]
5. **pvc** [*name*] *vpi / vci*
6. **pppoe max-sessions** *number-of-sessions* [**threshold-sessions** *number-of-sessions*]
7. **protocol pppoe**
8. **end**
9. **more system:running-config**

DETAILED STEPS

	Command or Action	Purpose
Step 1	enable Example: Router> enable	Enables privileged EXEC mode. • Enter your password if prompted.
Step 2	configure terminal Example: Router# configure terminal	Enters global configuration mode.
Step 3	snmp-server enable traps pppoe Example: Router(config)# snmp-server enable traps pppoe	(Optional) Enables PPPoE session count SNMP notifications. • This command enables SNMP traps that send notification messages when PPPoE session thresholds have been reached.
Step 4	interface atm <i>slot / subslot / port</i> [<i>.subinterface</i>] [multipoint point-to-point] Example: Router(config)# interface atm 0/0/0.3 point-to-point	Configures the ATM interface and enters subinterface configuration mode.
Step 5	pvc [<i>name</i>] <i>vpi / vci</i> Example: Router(config-subif)# pvc 5/120	Creates an ATM PVC and enters ATM VC configuration mode.
Step 6	pppoe max-sessions <i>number-of-sessions</i> [threshold-sessions <i>number-of-sessions</i>]	Sets the maximum number of PPPoE sessions that will be permitted on an ATM PVC, PVC range, VC class, or VLAN,

	Command or Action	Purpose
	<p>Example:</p> <pre>Router(config-if-atm-vc)# pppoe max-sessions 5 threshold-sessions 3</pre>	and sets the PPPoE session-count threshold at which an SNMP trap will be generated.
Step 7	<p>protocol pppoe</p> <p>Example:</p> <pre>Router(config-if-atm-vc)# protocol pppoe</pre>	Enables PPPoE sessions to be established on ATM PVCs.
Step 8	<p>end</p> <p>Example:</p> <pre>Router(config-if-atm-vc)# end</pre>	(Optional) Exits ATM VC configuration mode and returns to sub interface mode.
Step 9	<p>more system:running-config</p> <p>Example:</p> <pre>Router(#) more system:running-config</pre>	Displays the running configuration and the PPPoE session-count thresholds.

Configuring the PPPoE Session-Count Threshold for a VC Class

Perform this task to configure the PPPoE session-count threshold for a VC class.

SUMMARY STEPS

1. **enable**
2. **configure terminal**
3. **snmp-server enable traps pppoe**
4. **vc-class atm *name***
5. **pppoe max-sessions *number-of-sessions* [threshold-sessions *number-of-sessions*]**
6. **protocol pppoe [group *group-name* | global]**
7. **end**
8. **more system:running-config**

DETAILED STEPS

	Command or Action	Purpose
Step 1	enable	Enables privileged EXEC mode.

	Command or Action	Purpose
	<p>Example:</p> <pre>Router> enable</pre>	<ul style="list-style-type: none"> Enter your password if prompted.
Step 2	<p>configure terminal</p> <p>Example:</p> <pre>Router# configure terminal</pre>	Enters global configuration mode.
Step 3	<p>snmp-server enable traps pppoe</p> <p>Example:</p> <pre>Router(config)# snmp-server enable traps pppoe</pre>	<p>(Optional) Enables PPPoE session count SNMP notifications.</p> <ul style="list-style-type: none"> This command enables SNMP traps that send notification messages when PPPoE session thresholds have been reached.
Step 4	<p>vc-class atm name</p> <p>Example:</p> <pre>Router(config)# vc-class atm main</pre>	Creates a VC class for an ATM PVC, or SVC, or ATM interface and enters VC class configuration mode.
Step 5	<p>pppoe max-sessions number-of-sessions [threshold-sessions number-of-sessions]</p> <p>Example:</p> <pre>Router(config-vc-class)# pppoe max-sessions 7 threshold-sessions 3</pre>	Sets the maximum number of PPPoE sessions that will be permitted on an ATM PVC, PVC range, VC class, or VLAN, and sets the PPPoE session-count threshold at which an SNMP trap will be generated.
Step 6	<p>protocol pppoe [group group-name global]</p> <p>Example:</p> <pre>Router(config-vc-class)# protocol pppoe group one</pre>	Enables PPPoE sessions to be established.
Step 7	<p>end</p> <p>Example:</p> <pre>Router(config-vc-class)# end</pre>	(Optional) Exits VC class configuration mode and returns to privileged EXEC mode.
Step 8	<p>more system:running-config</p> <p>Example:</p> <pre>Router(#) more system:running-config</pre>	Displays the running configuration and the PPPoE session-count thresholds.

Configuring the PPPoE Session-Count Threshold for an ATM PVC Range

SUMMARY STEPS

1. **enable**
2. **configure terminal**
3. **snmp-server enable traps pppoe**
4. **interface atm slot / subslot / port [.subinterface] [multipoint | point-to-point]**
5. **range [range-name] pvc start-vpi / start-vci end-vpi / end-vci**
6. **pppoe max-sessions number-of-sessions [threshold-sessions number-of-sessions]**
7. **protocol pppoe [group group-name | global]**
8. **end**
9. **more system:running-config**

DETAILED STEPS

	Command or Action	Purpose
Step 1	enable Example: Router> enable	Enables privileged EXEC mode. <ul style="list-style-type: none"> • Enter your password if prompted.
Step 2	configure terminal Example: Router# configure terminal	Enters global configuration mode.
Step 3	snmp-server enable traps pppoe Example: Router(config)# snmp-server enable traps pppoe	(Optional) Enables PPPoE session count SNMP notifications. <ul style="list-style-type: none"> • This command enables SNMP traps that send notification messages when PPPoE session thresholds have been reached.
Step 4	interface atm slot / subslot / port [.subinterface] [multipoint point-to-point] Example: Router(config)# interface atm 0/0/0.3 point-to-point	Configures the ATM interface and enters the subinterface configuration mode.

	Command or Action	Purpose
Step 5	<p>range [<i>range-name</i>] pvc <i>start-vpi / start-vci end-vpi / end-vci</i></p> <p>Example:</p> <pre>Router(config-subif)# range pvc 3/100 3/105</pre>	Defines a range of ATM PVCs and enters ATM PVC range configuration mode.
Step 6	<p>pppoe max-sessions <i>number-of-sessions</i> [threshold-sessions <i>number-of-sessions</i>]</p> <p>Example:</p> <pre>Router(config-if-atm-range)# pppoe max-sessions 20 threshold-sessions 15</pre>	Sets the maximum number of PPPoE sessions that will be permitted on an ATM PVC, PVC range, VC class, or VLAN, and sets the PPPoE session-count threshold at which an SNMP trap will be generated.
Step 7	<p>protocol pppoe [group <i>group-name</i> global]</p> <p>Example:</p> <pre>Router(config-if-atm-range)# protocol pppoe group two</pre>	Enables PPPoE sessions to be established.
Step 8	<p>end</p> <p>Example:</p> <pre>Router(config-if-atm-range)# end</pre>	(Optional) Exits ATM PVC range configuration mode and returns to privileged EXEC mode.
Step 9	<p>more system:running-config</p> <p>Example:</p> <pre>Router(#) more system:running-config</pre>	Displays the running configuration and the PPPoE session-count thresholds.

Configuring the PPPoE Session-Count Threshold for an Individual PVC Within a Range

Perform this task to configure the PPPoE session-count threshold for an individual PVC within an ATM PVC range.

SUMMARY STEPS

1. **enable**
2. **configure terminal**
3. **snmp-server enable traps pppoe**
4. **interface atm slot / subslot / port [.subinterface] [multipoint | point-to-point]**
5. **range [range-name] pvc start-vpi / start-vci end-vpi /end-vci**
6. **pvc-in-range [pvc-name] [vpi / vci]**
7. **pppoe max-sessions number-of-sessions [threshold-sessions number-of-sessions]**
8. **end**
9. **more system:running-config**

DETAILED STEPS

	Command or Action	Purpose
Step 1	enable Example: Router> enable	Enables privileged EXEC mode. <ul style="list-style-type: none"> • Enter your password if prompted.
Step 2	configure terminal Example: Router# configure terminal	Enters global configuration mode.
Step 3	snmp-server enable traps pppoe Example: Router(config)# snmp-server enable traps pppoe	(Optional) Enables PPPoE session count SNMP notifications. <ul style="list-style-type: none"> • This command enables SNMP traps that send notification messages when PPPoE session thresholds have been reached.
Step 4	interface atm slot / subslot / port [.subinterface] [multipoint point-to-point] Example: Router(config)# interface atm 6/0.110 multipoint	Configures the ATM interface and enters subinterface configuration mode.
Step 5	range [range-name] pvc start-vpi / start-vci end-vpi /end-vci Example: Router(config-subif)# range range1 pvc 3/100 4/199	Defines a range of ATM PVCs and enters ATM PVC Range configuration mode.

	Command or Action	Purpose
Step 6	<p>pvc-in-range [<i>pvc-name</i>] [<i>vpi / vci</i>]</p> <p>Example:</p> <pre>Router(config-if-atm-range)# pvc-in-range pvc1 3/104</pre>	Configures an individual PVC within a PVC range and enters ATM PVC-in-range configuration mode.
Step 7	<p>pppoe max-sessions <i>number-of-sessions</i> [threshold-sessions <i>number-of-sessions</i>]</p> <p>Example:</p> <pre>Router(cfg-if-atm-range-pvc)# pppoe max-sessions 10 threshold-sessions 5</pre>	Sets the maximum number of PPPoE sessions that will be permitted on an ATM PVC, PVC range, VC class, or VLAN, and sets the PPPoE session-count threshold at which an SNMP trap will be generated.
Step 8	<p>end</p> <p>Example:</p> <pre>Router(cfg-if-atm-range-pvc)# end</pre>	(Optional) Exits ATM PVC-in-range configuration mode and returns to privileged EXEC mode.
Step 9	<p>more system:running-config</p> <p>Example:</p> <pre>Router(#) more system:running-config</pre>	Displays the running configuration and the PPPoE session-count thresholds.

Monitoring and Maintaining PPPoE Session Counts and SNMP Notifications

Perform the following task to monitor PPPoE sessions counts and SNMP notifications.

SUMMARY STEPS

1. **enable**
2. **debug snmp packets**
3. **debug pppoe errors** [*rmac remote-mac-address* | **interface** *type number* [**vc** {[*vpi /vci* | *vc-name*}] [**vlan** *vlan-id*]]
4. **debug pppoe events** [*rmac remote-mac-address* | **interface** *type number* [**vc** {[*vpi /vci* | *vc-name*}] [**vlan** *vlan-id*]]
5. **show vpdn session**
6. **show pppoe session**

DETAILED STEPS

Step 1 enable

Use this command to enable privileged EXEC mode. Enter your password when prompted.

Example:

```
Router> enable
```

Step 2 debug snmp packets

Use this command to display information about every SNMP packet sent or received by the router:

Example:

```
Router# debug snmp packets
SNMP: Packet received via UDP from 192.0.2.11 on GigabitEthernet1/0
SNMP: Get-next request, reqid 23584, errstat 0, erridx 0
  sysUpTime = NULL TYPE/VALUE
  system.1 = NULL TYPE/VALUE
  system.6 = NULL TYPE/VALUE
SNMP: Response, reqid 23584, errstat 0, erridx 0
  sysUpTime.0 = 2217027
  system.1.0 = Cisco Internetwork Operating System Software
  system.6.0 =
SNMP: Packet sent via UDP to 192.0.2.11
```

Step 3 debug pppoe errors [rmac remote-mac-address | interface type number [vc {[vpi /]vci | vc-name}] [vlan vlan-id]]

Use this command to display PPPoE protocol errors that prevent a session from being established or errors that cause an established session to be closed.

Example:

```
Router# debug pppoe errors interface atm 1/0.10
PPPoE protocol errors debugging is on
Router#
00:44:30:PPPoE 0:Max session count(1) on mac(00b0.c2e9.c470) reached.
00:44:30:PPPoE 0:Over limit or Resource low. R:00b0.c2e9.c470 L:ffff.ffff.ffff 0/101
ATM1/0.10
```

Step 4 debug pppoe events [rmac remote-mac-address | interface type number [vc {[vpi /]vci | vc-name}] [vlan vlan-id]]

Use this command to display PPPoE protocol messages about events that are part of normal session establishment or shutdown:

Example:

```
Router# debug pppoe events interface atm 1/0.10 vc 101

PPPoE protocol events debugging is on
Router#
00:41:55:PPPoE 0:I PADI R:00b0.c2e9.c470 L:ffff.ffff.ffff 0/101 ATM1/0.10
00:41:55:PPPoE 0:O PADO, R:00b0.c2e9.c470 L:0001.c9f0.0c1c 0/101 ATM1/0.10
00:41:55:PPPoE 0:I PADR R:00b0.c2e9.c470 L:0001.c9f0.0c1c 0/101 ATM1/0.10
00:41:55:PPPoE :encap string prepared
00:41:55:[3]PPPoE 3:Access IE handle allocated
00:41:55:[3]PPPoE 3:pppoe SSS switch updated
00:41:55:[3]PPPoE 3:AAA unique ID allocated
00:41:55:[3]PPPoE 3:No AAA accounting method list
00:41:55:[3]PPPoE 3:Service request sent to SSS
00:41:55:[3]PPPoE 3:Created R:0001.c9f0.0c1c L:00b0.c2e9.c470 0/101 ATM1/0.10
```

```

00:41:55:[3]PPPoE 3:State REQ_NASPORT      Event MORE_KEYS
00:41:55:[3]PPPoE 3:O PADS  R:00b0.c2e9.c470 L:0001_c9f0.0c1c 0/101 ATM1/0.10
00:41:55:[3]PPPoE 3:State START_PPP      Event DYN_BIND
00:41:55:[3]PPPoE 3:data path set to PPP
00:41:57:[3]PPPoE 3:State LCP_NEGO       Event PPP_LOCAL
00:41:57:PPPoE 3/SB:Sent vtemplate request on base Vi2
00:41:57:[3]PPPoE 3:State CREATE_VA     Event VA_RESP
00:41:57:[3]PPPoE 3:Vi2.1 interface obtained
00:41:57:[3]PPPoE 3:State PTA_BIND      Event STAT_BIND
00:41:57:[3]PPPoE 3:data path set to Virtual Access
00:41:57:[3]PPPoE 3:Connected PTA

```

Step 5 **show vpdn session**

Use this command to display information about active Level 2 Forwarding (L2F) protocol tunnel and message identifiers on a VPDN:

Example:

```

Router# show vpdn session
%No active L2TP tunnels
%No active L2F tunnels
PPPoE Session Information Total tunnels 1 sessions 1
PPPoE Session Information
SID      RemMAC          LocMAC          Intf    VAST    OIntf    VC
1        0010.7b01.2cd9  0090.ab13.bca8  Vi4     UP      AT6/0    0/10

```

Step 6 **show pppoe session**

Use this command to display information about the currently active PPPoE sessions:

Example:

```

Router# show pppoe session
  3 sessions in LOCALLY_TERMINATED (PTA) State
  3 sessions total

Uniq ID  PPPoE  RemMAC          Port          VT  VA      State
        SID  LocMAC          VC:           VC:           VA-st      Type
  1      1    0007.b3dc.a41c  ATM0/3/1.100  1  Vi2.1  PTA
        001a.3045.0331 VC: 99/100    UP
  2      2    0007.b3dc.a41c  ATM0/3/1.100  1  Vi2.2  PTA
        001a.3045.0331 VC: 99/100    UP
  3      3    0007.b3dc.a41c  ATM0/3/1.100  1  Vi2.3  PTA
        001a.3045.0331 VC: 99/100    UP

Router#

```

Configuration Examples for Monitoring PPPoE Sessions with SNMP

Example: Configuring PPPoE Session-Count SNMP Traps

The following example shows how to enable the router to send PPPoE session-count SNMP notifications to the host at the address 192.10.2.10:

```
snmp-server community public RW
snmp-server enable traps pppoe
snmp-server host 192.10.2.10 version 2c public udp-port 1717
```

Example: Configuring PPPoE Session-Count Threshold for the Router

The following example shows a limit of 4000 PPPoE sessions configured for the router. The PPPoE session-count threshold is set at 3000 sessions, so when the number of PPPoE sessions on the router reaches 3000, an SNMP trap will be generated.

```
bba-group pppoe pppoel
sessions max limit 4000 threshold 3000
virtual-template 1
pppoe limit max-sessions 4000 threshold-sessions 3000
```

Example: Configuring PPPoE Session-Count Threshold for a PVC

The following example shows a limit of five PPPoE sessions configured for the PVC. The PPPoE session-count threshold is set at three sessions, so when the number of PPPoE sessions on the PVC reaches three, an SNMP trap will be generated.

```
interface ATM 0/0/0
ip address 10.0.0.1 255.255.255.0
no atm ilmi-keepalive
pvc 5/120
protocol ip 10.0.0.2 broadcast
pppoe max-sessions 5 threshold-sessions 3
protocol pppoe
```

Example: Configuring PPPoE Session-Count Threshold for a VC Class

The following example shows a limit of seven PPPoE sessions configured for a VC class called "main." The PPPoE session-count threshold is set at three sessions, so when the number of PPPoE sessions for the VC class reaches three, an SNMP trap will be generated.

```
vc-class atm main
protocol pppoe group global
vc-class atm global
protocol pppoe
pppoe max-sessions 7 threshold-sessions 3
```

Example: Configuring PPPoE Session-Count Threshold for a PVC Range

The following example shows a limit of 20 PPPoE sessions configured for the PVC range. The PPPoE session-count threshold will also be 20 sessions because when the session-count threshold has not been explicitly configured, it defaults to the PPPoE session limit. An SNMP trap will be generated when the number of PPPoE sessions for the range reaches 20.

```
interface ATM 0/0/0.3 point-to-point
 range pvc 3/100 3/105
  pppoe max-sessions 20 threshold-sessions 15
 protocol pppoe
```

PPPoE Session-Count Threshold for an Individual PVC Within a PVC Range Example

The following example shows a limit of ten PPPoE sessions configured for pvc1. The PPPoE session-count threshold is set at three sessions, so when the number of PPPoE sessions for the PVC reaches three, an SNMP trap will be generated.

```
interface atm 6/0.110 multipoint
 range range1 pvc 100 4/199
  pvc-in-range pvc1 3/104
  pppoe max-sessions 10 threshold-sessions 3
```

Where to Go Next

- If you want to establish PPPoE session limits for sessions on a specific PVC or VLAN configured on an L2TP access concentrator, refer to the "Establishing PPPoE Session Limits per NAS Port" module.
- If you want to use service tags to enable a PPPoE server to offer PPPoE clients a selection of service during call setup, refer to the "Offering PPPoE Clients a Selection of Services During Call Setup" module.
- If you want to enable an L2TP access concentrator to relay active discovery and service selection functionality for PPPoE over an L2TP control channel to a LNS or tunnel switch, refer to the "Enabling PPPoE Relay Discovery and Service Selection Functionality" module.
- If you want to configure the transfer upstream of the PPPoX session speed value, refer to the "Configuring Upstream Connection Speed Transfer" module.
- If you want to identify a physical subscriber line for RADIUS communication with a RADIUS server, refer to the "Identifying the Physical Subscriber Line for RADIUS Access and Accounting" module.
- If you want to configure a Cisco Subscriber Service Switch, refer to the "Configuring Cisco Subscriber Service Switch Policies" module.

Additional References

The following sections provide references related to monitoring PPPoE sessions with SNMP.

Related Documents

Related Topic	Document Title
Broadband access aggregation concepts	Understanding Broadband Access Aggregation
Tasks for preparing for broadband access aggregation	Preparing for Broadband Access Aggregation
Configuring PPPoE sessions	Providing Protocol Support for Broadband Access Aggregation of PPPoE Sessions
Establishing PPPoE session limits for sessions on a specific PVC or VLAN configured on an L2TP access concentrator	Establishing PPPoE Session Limits per NAS Port
Using service tags to enable a PPPoE server to offer PPPoE clients a selection of service during call setup	Offering PPPoE Clients a Selection of Services During Call Setup
Enabling an L2TP access concentrator to relay active discovery and service selection functionality for PPPoE over an L2TP control channel to a LNS or tunnel switch	Enabling PPPoE Relay Discovery and Service Selection Functionality
Configuring the transfer upstream of the PPPoX session speed value	Configuring Upstream Connection Speed Transfer
Identifying a physical subscriber line for RADIUS communication with a RADIUS server	Identifying the Physical Subscriber Line for RADIUS Access and Accounting
Configuring a Cisco Subscriber Service Switch	Configuring Cisco Subscriber Service Switch Policies

Standards

Standards	Title
None	--

MIBs

MIBs	MIBs Link
PPPoE Session Count MIB	To locate and download MIBs for selected platforms, Cisco IOS XE software releases, and feature sets, use Cisco MIB Locator found at the following URL: http://tools.cisco.com/ITDIT/MIBS/servlet/index http://tools.cisco.com/ITDIT/MIBS/servlet/index

RFCs

RFCs	Title
None	--

Technical Assistance

Description	Link
<p>The Cisco Support website provides extensive online resources, including documentation and tools for troubleshooting and resolving technical issues with Cisco products and technologies.</p> <p>To receive security and technical information about your products, you can subscribe to various services, such as the Product Alert Tool (accessed from Field Notices), the Cisco Technical Services Newsletter, and Really Simple Syndication (RSS) Feeds.</p> <p>Access to most tools on the Cisco Support website requires a Cisco.com user ID and password.</p>	http://www.cisco.com/techsupport

Feature Information for Monitoring PPPoE Sessions with SNMP

The following table provides release information about the feature or features described in this module. This table lists only the software release that introduced support for a given feature in a given software release train. Unless noted otherwise, subsequent releases of that software release train also support that feature.

Use Cisco Feature Navigator to find information about platform support and Cisco software image support. To access Cisco Feature Navigator, go to www.cisco.com/go/cfn. An account on Cisco.com is not required.

Table 30: Feature Information for Monitoring PPPoE Sessions with SNMP

Feature Name	Releases	Feature Configuration Information
PPPoE Session Count MIB, SNMP Traps for PPPoE Session Limits	Cisco IOS XE Release 2.5.0 Cisco IOS XE Release 2.6	<p>This feature was introduced on Cisco ASR 1000 Series Aggregation Routers.</p> <p>This feature provides the ability to use SNMP to monitor in real time the number of PPP over Ethernet sessions configured on PVCs and on a router. You can also retrieve information from the MIB.</p> <p>The SNMP Traps for PPPoE Session Limits feature implements SNMP MIB support for the PPPoE session limits and generates notifications in case the limits are reached.</p> <p>The following commands were introduced or modified:</p> <p>snmp-server enable traps pppoe</p>



PPPoE on ATM

This feature module describes the PPP over Ethernet (PPPoE) on ATM feature. The PPPoE on ATM feature provides the ability to connect a network of hosts over a simple bridging-access device to a remote access concentrator.

- [Finding Feature Information, page 275](#)
- [Prerequisites for PPPoE on ATM, page 275](#)
- [Restrictions for PPPoE on ATM, page 276](#)
- [Information About PPPoE on ATM, page 276](#)
- [How to Configure PPPoE on ATM, page 278](#)
- [Configuration Examples for PPPoE on ATM, page 283](#)
- [Where to Go Next, page 284](#)
- [Additional References, page 284](#)
- [Feature Information for PPPoE on ATM, page 286](#)
- [Glossary, page 286](#)

Finding Feature Information

Your software release may not support all the features documented in this module. For the latest caveats and feature information, see [Bug Search Tool](#) and the release notes for your platform and software release. To find information about the features documented in this module, and to see a list of the releases in which each feature is supported, see the feature information table.

Use Cisco Feature Navigator to find information about platform support and Cisco software image support. To access Cisco Feature Navigator, go to www.cisco.com/go/cfn. An account on Cisco.com is not required.

Prerequisites for PPPoE on ATM

Before you can configure PPPoE on ATM, you need to specify a virtual template for the PPPoE sessions using the **virtual-template** command.

Restrictions for PPPoE on ATM

- PPPoE is not supported on Frame Relay.
- PPPoE over ATM AAL5Mux is not supported on ASR series 1000 routers. For more information, refer to the PPPoEoA over ATM AAL5Mux feature:
http://www.cisco.com/en/US/docs/ios/bbds/ configuration/guide/bba_pppoeoa_aal5mux.html
- PPPoE is not supported on any other LAN interfaces such as FDDI and Token Ring.
- Fast switching is supported. PPPoE over RFC 1483 fibswitching is supported for IP. All other protocols are switched over process switching.
- Bridging is supported on the ATM permanent virtual connections (PVCs) running PPPoE.
- PPPoE is supported on ATM PVCs compliant with RFC 1483 only.
- Only dial-in mode is supported. Dial-out mode will not be supported.

Information About PPPoE on ATM

The PPPoE on ATM feature provides the ability to connect a network of hosts over a simple bridging-access device to a remote access concentrator. With this model, each host utilizes its own PPPoE stack and the user is presented with a familiar user interface. Access control, billing and type of service can be done on a per-user, rather than a per-site, basis. Before a point-to-point connection over Ethernet can be provided, each PPP session must learn the Ethernet address of the remote peer and establish a unique session identifier. A unique session identifier is provided by the PPPoE Discovery Stage protocol.

The figure below shows a sample network topology using PPPoE on ATM.

Figure 18: PPPoE on ATM Sample Network Topology

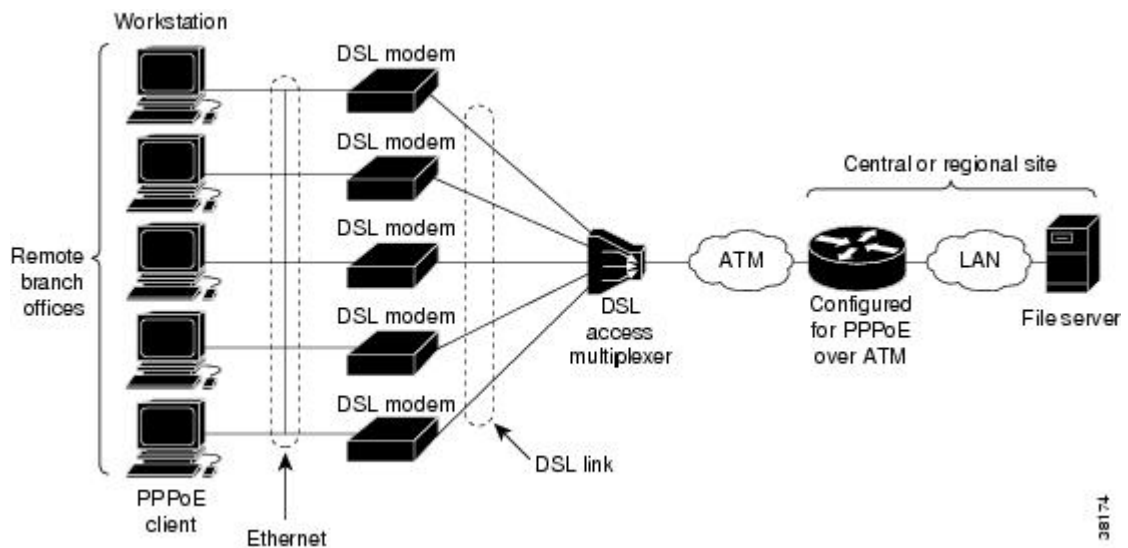

PPPoE Stage Protocols

PPPoE has two distinct stage protocols. The stage protocols are listed and summarized in the table below.

Table 31: PPPoE Stage Protocols

Stage Protocols	Description
Discovery Stage protocol	Remains stateless until a PPPoE session is established. Once the PPPoE session is established, both the host and the access concentrator <i>must</i> allocate the resources for a PPP virtual access interface.
PPP Session Stage protocol	Once the PPPoE session is established, sends PPPoE data as in any other PPP encapsulation.

There are four steps to the Discovery Stage:

- 1 Host broadcasts a PPPoE Active Discovery Initiation (PADI) packet.
- 2 When the access concentrator receives a PADI that it can serve, it replies by sending a PPPoE Active Discovery Offer (PADO) packet to the host.
- 3 Because the PADI was broadcast, the host may receive more than one PADO packet. The host looks through the PADO packets it receives and chooses one. The choice can be based on the AC name or the services offered. The host then sends a single PPPoE Active Discovery Request (PADR) packet to the access concentrator that it has chosen.
- 4 When the access concentrator receives a PADR packet, it prepares to begin a PPP session. It generates a unique SESSION_ID for the PPPoE session and replies to the host with a PPPoE Active Discovery Session-confirmation (PADS) packet.

When a host wishes to initiate a PPPoE session, it must first perform discovery to identify the Ethernet MAC address of the peer and establish a PPPoE SESSION_ID. Although PPP defines a peer-to-peer relationship, discovery is inherently a client/server relationship. In the discovery process, a host (the client) discovers an access concentrator (the server). Based on the network topology, there may be more than one access concentrator that the host can communicate with. The Discovery Stage allows the host to discover all access concentrators and then select one. When discovery is completed, both the host and the selected access concentrator have the information they will use to build their point-to-point connection over Ethernet.

Benefits of PPPoE on ATM

The PPPoE on ATM feature provides service-provider digital subscriber line (DSL) support. As service providers begin DSL deployments, two of their most significant goals are to ease and facilitate consumer end adoption and to preserve as much of the dialup model as possible. PPPoE serves to advance both of these goals by leveraging ethernet scale curves and embedded base (such as ATM NICs) and by preserving the point-to-point session used by internet service providers (ISPs) in today's dialup model.

Using a PPPoE client (available from RouterWare), a PPP session can be initiated on an Ethernet connected client through a standard ADSL modem. The session is transported over the ATM DSL link via RFC 1483

Ethernet bridged frames and can terminate either in the LAN emulation client (LEC) central office or the ISP point of presence (POP). The termination device can be an aggregation box such as the Cisco 6400 or a router such as the Cisco 7200 series platforms.

As customers deploy asymmetric DSL (ADSL), they will encounter the need to enable users to access remote-access concentrators via simple bridges connecting Ethernet and ATM networks.

How to Configure PPPoE on ATM

Enabling PPP over ATM

After you configure the Cisco router or access server for Ethernet encapsulation, you must configure the physical interface with the PVC and apply a virtual template with PPP encapsulation to the PVC that it applies to. To configure the physical interface that will carry the PPPoE session and link it to the appropriate virtual template interface, use the following commands:



Note

You can use the **virtual-template**, **sessions per-vc**, and **sessions per-mac** commands in any order.

SUMMARY STEPS

1. **enable**
2. **configure terminal**
3. **bba-group pppoe** *{group-name | global}*
4. **virtual-template** *template-number*
5. **sessions per-vc limit** *per-vc-limit* [**threshold** *threshold-value*]
6. **sessions per-mac limit** *per-mac-limit*
7. **exit**
8. **interface atm** *slot / subslot / port* [*.subinterface*][**point-to-point** | **multipoint**]
9. **ip address** *ip-address mask* [**secondary**]
10. **range** [*range-name*] **pvc** *start-vpi / start-vci end-vpi / end-vci*
11. **dbcs enable** [**aggregated** | **maximum**]
12. Do one of the following:
 - **protocol pppoe group** *{group-name | global}*
 - or
 - **encapsulation aal5snap**
13. **create on-demand**
14. **end**

DETAILED STEPS

	Command or Action	Purpose
Step 1	enable Example: Router> enable	Enables privileged EXEC mode. <ul style="list-style-type: none"> • Enter your password if prompted.
Step 2	configure terminal Example: Router# configure terminal	Enters global configuration mode.
Step 3	bba-group pppoe <i>{group-name global}</i> Example: Router(config)# bba-group pppoe pppoe-group	Defines a PPPoE profile, and enters BBA group configuration mode. <ul style="list-style-type: none"> • The global keyword creates a profile that serves as the default profile for any PPPoE port that is not assigned a specific profile.
Step 4	virtual-template <i>template-number</i> Example: Router(config-bba-group)# virtual-template 1	Specifies which virtual template will be used to clone virtual access interfaces.
Step 5	sessions per-vc limit <i>per-vc-limit</i> [threshold <i>threshold-value</i>] Example: Router(config-bba-group)# sessions max limit 1	Configures the PPPoE global profile with the maximum number of PPPoE sessions permitted on a router and sets the PPPoE session-count threshold at which an Simple Network Management Protocol (SNMP) trap will be generated. <p>Note This command applies only to the global profile.</p>
Step 6	sessions per-mac limit <i>per-mac-limit</i> Example: Router(config-bba-group)# sessions per-mac limit 4000	Sets the maximum number of PPPoE sessions permitted per MAC address in a PPPoE profile.
Step 7	exit Example: Router(config-bba-group)# exit	Exits BBA group configuration mode and returns to global configuration mode.

	Command or Action	Purpose
Step 8	interface atm <i>slot / subslot / port</i> <i>[.subinterface][point-to-point multipoint]</i> Example: Router(config)# interface atm 1/0.1 multipoint	Specifies the ATM interface and enters subinterface configuration mode.
Step 9	ip address <i>ip-address mask</i> [secondary] Example: Router(config-subif)# ip address 192.0.10.2 255.255.255.0 secondary	Sets a primary or secondary IP address for an interface.
Step 10	range [<i>range-name</i>] pvc <i>start-vpi / start-vci end-vpi / end-vci</i> Example: Router(config-if)# range pvc 101/304 200/400	Defines a range of ATM permanent virtual circuits (PVCs) and enters ATM range configuration mode.
Step 11	dbns enable [aggregated maximum] Example: Router(config-if-atm-range)# dbns enable	Applies the Dynamic Subscriber Bandwidth Selection (DBS) QoS parameters.
Step 12	Do one of the following: <ul style="list-style-type: none"> • protocol pppoe group {<i>group-name</i> global} • or • encapsulation aal5snap Example: Router(config-if-atm-range-pvc)# protocol pppoe group two Example: Example: Example: Router(config-if-atm-range-pvc)# encapsulation aal5snap	Enables PPPoE sessions to be established on a PVC within a range. or Configures PPPoE autosense. <ul style="list-style-type: none"> • If a PPPoE profile is not assigned to the PVC by using the group <i>group-name</i> option, the PVC will use the global PPPoE profile.

	Command or Action	Purpose
Step 13	<p>create on-demand</p> <p>Example:</p> <pre>Router(config-if-atm-range)# create on-demand</pre>	Configures ATM PVC autoprovisioning, which enables a range of PVCs to be created automatically on demand.
Step 14	<p>end</p> <p>Example:</p> <pre>Router(config-if-atm-range)# end</pre>	(Optional) Exits the ATM range configuration mode and returns to privileged EXEC mode.

Creating and Configuring a Virtual Template

Specifying an ATM Subinterface

After you create a virtual template for PPPoE on ATM, specify a multipoint or point-to-point subinterface per PVC connection. To specify an ATM multipoint subinterface, use the following commands:

SUMMARY STEPS

1. **enable**
2. **configure terminal**
3. **interface atm** *slot / subslot / port .subinterface* [**multipoint**| **point-to-point**]
4. **end**

DETAILED STEPS

	Command or Action	Purpose
Step 1	<p>enable</p> <p>Example:</p> <pre>Router> enable</pre>	<p>Enables privileged EXEC mode.</p> <ul style="list-style-type: none"> • Enter your password if prompted.
Step 2	<p>configure terminal</p> <p>Example:</p> <pre>Router# configure terminal</pre>	Enters global configuration mode.

	Command or Action	Purpose
Step 3	interface atm <i>slot / subslot / port</i> <i>.subinterface</i>] [multipoint point-to-point] Example: Router# interface atm 6/0.110 multipoint	Configures the ATM interface and enters subinterface configuration mode. <ul style="list-style-type: none"> • A multipoint subinterface is recommended for interface conservation. A point-to-point subinterface will greatly restrict the total number of PPPoE sessions you can have.
Step 4	end Example: Router(config-subif)# end	(Optional) Exits the subinterface configuration mode and returns to privileged EXEC mode.

Creating an ATM PVC

Enabling PPPoE on an ATM PVC

To enable PPPoE on an ATM PVC, use the following commands:

SUMMARY STEPS

1. **enable**
2. **configure terminal**
3. **interface atm** *slot / subslot / port* [*.subinterface*] [**multipoint** | **point-to-point**]
4. **pvc** [*name*] *vpi / vci*
5. **pppoe max-sessions** *number-of-sessions* [**threshold-sessions** *number-of-sessions*]
6. **protocol pppoe**
7. **end**

DETAILED STEPS

	Command or Action	Purpose
Step 1	enable Example: Router> enable	Enables privileged EXEC mode. <ul style="list-style-type: none"> • Enter your password if prompted.

	Command or Action	Purpose
Step 2	configure terminal Example: Router# configure terminal	Enters global configuration mode.
Step 3	interface atm slot / subslot / port [.subinterface] [multipoint point-to-point] Example: Router(config)# interface atm 0/0/0.3 multipoint	Configures the ATM interface and enters the subinterface configuration mode.
Step 4	pvc [name] vpi / vci Example: Router(config-subif)# pvc 5/120	Creates an ATM PVC and enters ATM VC configuration mode.
Step 5	pppoe max-sessions number-of-sessions [threshold-sessions number-of-sessions] Example: Router(config-if-atm-vc)# pppoe max-sessions 5 threshold-sessions 3	Sets the maximum number of PPPoE sessions that will be permitted on an ATM PVC, PVC range, VC class, or VLAN, and sets the PPPoE session-count threshold at which an SNMP trap will be generated.
Step 6	protocol pppoe Example: Router(config-if-atm-vc)# protocol pppoe	Enables PPPoE sessions to be established on ATM PVCs.
Step 7	end Example: Router(config-if-atm-vc)# end	(Optional) Exits the ATM VC configuration mode and returns to privileged EXEC mode.

Configuration Examples for PPPoE on ATM

PPPoE on ATM Example

The following example configures PPPoE on ATM to accept dial-in PPPoE sessions. The virtual access interface for the PPP session is cloned from virtual template interface 1. On subinterface ATM 2/0.1, ATM

PVC with VPI 0 and VCI 60 is configured with Logical Link Control (LLC)/Subnetwork Access Protocol (SNAP) encapsulation and is configured to run PPPoE.

```
bba-group pppoe pppoe-group
virtual-template 1
sessions per-vc limit 1
sessions per-mac limit 4000
interface atm 2/0.1 multipoint
ip address 192.0.10.2 255.255.255.0 secondary
range pvc 1/100 1/202
pvc 0/60
  dbs enable
  encapsulation aal5snap
  protocol pppoe group two
  create on-demand
interface virtual-template 1
ip addr 10.0.1.2 255.255.255.0
mtu 1492
```

Where to Go Next

- If you want to enable PPP authentication on the virtual template using the **ppp authentication chap** command, refer to the "Configuring Virtual Template Interfaces" chapter in the *Cisco IOS Dial Solutions Configuration Guide* .
- If you want to configure an authentication, authorization, and accounting (AAA) server, refer to the "Configuring per-User Configuration" chapter in the *Cisco IOS Dial Solutions Configuration Guide* .

Additional References

The following sections provide references related to the PPPoE on ATM feature.

Related Documents

Related Topic	Document Title
Cisco IOS commands	Cisco IOS Master Commands List, All Releases
Broadband and DSL commands	<i>Cisco IOS Broadband Access Aggregation and DSL Command Reference</i>
Enabling PPP authentication on the virtual template	Configuring Virtual Template Interfaces
Configuring an AAA server	Configuring per-User Configuration
Configuring Broadband and DSL	<i>Cisco IOS XE Broadband Access Aggregation and DSL Configuration Guide</i>

Standards

Standard	Title
None	--

MIBs

MIB	MIBs Link
	To locate and download MIBs for selected platforms, Cisco IOS XE software releases, and feature sets, use Cisco MIB Locator found at the following URL: http://www.cisco.com/go/mibs

RFCs

RFC	Title
RFC 1483	<i>Multiprotocol Encapsulation over ATM Adaptation Layer 5</i>
RFC 2364	<i>PPP over AAL5</i>
RFC 2516	<i>A Method for Transmitting PPP over Ethernet (PPPoE)</i>

Technical Assistance

Description	Link
<p>The Cisco Support website provides extensive online resources, including documentation and tools for troubleshooting and resolving technical issues with Cisco products and technologies.</p> <p>To receive security and technical information about your products, you can subscribe to various services, such as the Product Alert Tool (accessed from Field Notices), the Cisco Technical Services Newsletter, and Really Simple Syndication (RSS) Feeds.</p> <p>Access to most tools on the Cisco Support website requires a Cisco.com user ID and password.</p>	http://www.cisco.com/cisco/web/support/index.html

Feature Information for PPPoE on ATM

The following table provides release information about the feature or features described in this module. This table lists only the software release that introduced support for a given feature in a given software release train. Unless noted otherwise, subsequent releases of that software release train also support that feature.

Use Cisco Feature Navigator to find information about platform support and Cisco software image support. To access Cisco Feature Navigator, go to www.cisco.com/go/cfn. An account on Cisco.com is not required.

Table 32: Feature Information for PPPoE on ATM

Feature Name	Releases	Feature Information
PPPoE on ATM	Cisco IOS XE Release 2.5	<p>This feature was introduced on Cisco ASR 1000 Series Aggregation Services Routers.</p> <p>This feature module describes the PPP over Ethernet (PPPoE) on ATM feature. The PPPoE on ATM feature provides the ability to connect a network of hosts over a simple bridging-access device to a remote access concentrator.</p> <p>The following commands were introduced or modified: bba-group, protocol (VPDN), virtual-template.</p>

Glossary

- AAL5** --ATM Adaptation Layer 5
- ADSL** --Asymmetric Digital Subscriber Line
- ATM** --Asynchronous Transfer Mode
- CPCS** --Common Part of Convergence Sublayer
- CPI** --Common Part Indicator
- CRC** --Cyclic Redundancy Check
- DSLAM** --Digital Subscriber Line Access Multiplexer
- FCS** --Frame Check Sequence
- IETF** --Internet Engineering Task Force
- ID** -Identifier
- IP** --Internet Protocol
- L2TP** --Layer two Tunneling Protocol

LAN --Local Area Network
LLC --Logical Link Control
MAC --Media Access Control
PDU --Protocol Data Unit
PPP --Point to Point Protocol
PPPoE --Point to Point Protocol over Ethernet
PVC --Permanent Virtual Connection
VPDN --Virtual Private Dialup Network



PPPoE on Ethernet

The PPPoE on Ethernet feature adds support to Point-to-Point Protocol over Ethernet (PPPoE) by adding direct connection to actual Ethernet interfaces. PPPoE provides service-provider digital subscriber line (DSL) support. This Ethernet specification can be used by multiple hosts on a shared Ethernet interface to open PPP sessions to multiple destination with one or more bridging modems.

- [Finding Feature Information, page 289](#)
- [Prerequisites for PPPoE on Ethernet, page 289](#)
- [Restrictions for PPPoE on Ethernet, page 290](#)
- [Information About PPPoE on Ethernet, page 290](#)
- [How to Enable and Configure PPPoE on Ethernet, page 290](#)
- [Configuration Examples for PPPoE on Ethernet, page 293](#)
- [Additional References, page 294](#)
- [Feature Information for PPPoE on Ethernet, page 295](#)

Finding Feature Information

Your software release may not support all the features documented in this module. For the latest caveats and feature information, see [Bug Search Tool](#) and the release notes for your platform and software release. To find information about the features documented in this module, and to see a list of the releases in which each feature is supported, see the feature information table.

Use Cisco Feature Navigator to find information about platform support and Cisco software image support. To access Cisco Feature Navigator, go to www.cisco.com/go/cfn. An account on Cisco.com is not required.

Prerequisites for PPPoE on Ethernet

Before you can configure the PPPoE on Ethernet feature, you need to configure a virtual private dialup network (VPDN) group using the **accept dialin** command, enable PPPoE, and specify a virtual template for PPPoE sessions.

Restrictions for PPPoE on Ethernet

- PPPoE is not supported on Frame Relay.
- PPPoE is not supported on any other LAN interfaces such as FDDI and Token Ring.
- Fast switching is supported. PPP over Ethernet over RFC 1483 fibswitching is supported for IP. All other protocols are switched over process switching.

Information About PPPoE on Ethernet

Benefits of Using PPPoE on Ethernet

Broadband Remote Access

For a bridged-Ethernet topology, the PPPoE on Ethernet feature allows access providers to maintain session abstraction associated with PPP networks.

PPPoE

PPPoE provides the ability to connect a network of hosts over a simple bridging access device to a remote access concentrator where each host utilizes its own PPP stack. It also gives users a familiar interface.

PPPoE provides service-provider DSL support. In service-provider DSL deployments, PPPoE leverages Ethernet scale curves and it uses an embedded base.

How to Enable and Configure PPPoE on Ethernet

Enabling PPPoE on Ethernet in a VPDN Group

To configure the physical interface that will carry the PPPoE session and link it to the appropriate virtual template interface, you need to complete the following steps.

SUMMARY STEPS

1. Router(config)# **vpdn enable**
2. Router(config-if)# **vpdn group** *name*
3. Router(config-if)# **accept dialin**
4. Router(config-if)# **protocol pppoe**
5. Router(config-if)# **virtual-template** *template-number*

DETAILED STEPS

	Command or Action	Purpose
Step 1	Router(config)# vpdn enable	Enables virtual private dial-up networking.
Step 2	Router(config-if)# vpdn group name	Associates a VPDN group to a customer or VPDN profile.
Step 3	Router(config-if)# accept dialin	Creates an accept dial-in VPDN group.
Step 4	Router(config-if)# protocol pppoe	Specifies the VPDN group to be used to establish PPPoE sessions.
Step 5	Router(config-if)# virtual-template template-number	Specifies which virtual template will be used to clone virtual access interfaces.

Limiting PPPoE Sessions from a MAC Address

To set the limit of sessions to be sourced from a MAC address, use the following command in VPDN configuration mode:

Command	Purpose
Router(config-if)# pppoe session-limit per-mac number	Sets the limit of sessions to be sourced from a MAC address.

Creating and Configuring a Virtual Template

Other optional configuration commands can be added to the virtual template configuration. For example, you can enable the PPP authentication on the virtual template using the **ppp authentication chap** command. See the "Virtual Interface Template Service" chapter in the *Cisco IOS Dial Solutions Configuration Guide* for more information about configuring the virtual template.

Although Cisco Express Forwarding switching is supported, flow, and optimum switching are not; these configurations are ignored on the PPPoE virtual access interface. Cisco Express Forwarding is enabled by default for IP. All other protocol traffic will be processed switched.

**Note**

The PPP reliable link that uses Link Access Procedure, Balanced (LAPB) is not supported.

To create and configure a virtual template, use the following commands beginning in global configuration mode:

SUMMARY STEPS

1. Router(config)# **interface virtual-template** *number*
2. Router(config-if)# **ip unnumbered ethernet** *number*
3. Router(config-if)# **mtu** *bytes*

DETAILED STEPS

	Command or Action	Purpose
Step 1	Router(config)# interface virtual-template <i>number</i>	Creates a virtual template, and enters interface configuration mode.
Step 2	Router(config-if)# ip unnumbered ethernet <i>number</i>	Enables IP without assigning a specific IP address on the LAN.
Step 3	Router(config-if)# mtu <i>bytes</i>	Sets the maximum transmission unit (MTU) size for the interface.

Specifying an Ethernet Interface

After you create a virtual template for PPPoE on Ethernet, specify a multipoint or point-to-point interface. To specify an Ethernet multipoint interface, use the following commands in global configuration mode:

Command	Purpose
Router# interface ethernet <i>interface-number</i>	Specifies the Ethernet interface using the appropriate format of the interface ethernet command.

Enabling PPPoE on an Ethernet Interface

To enable PPPoE on Ethernet interfaces, use the following command in global configuration mode:

Command	Purpose
Router# pppoe enable	Specifies the VPDN group to be used for establishing PPPoE sessions.

Monitoring and Maintaining VPDN Groups

To monitor and maintain VPDN groups, use the following commands in EXEC mode:

Command	Purpose
Router# show vpdn	Displays information about active Level 2 Forwarding (L2F) Protocol tunnel and message identifiers in a VPDN.
Router# show vpdn session packet	Displays PPPoE session statistics.
Router# show vpdn session all	Displays PPPoE session information for each session ID.
Router# show vpdn tunnel	Displays PPPoE session count for the tunnel.

Configuration Examples for PPPoE on Ethernet

PPPoE on Ethernet Example

The following are examples of the **vpdn enable** and **interface virtual-template** commands:

```
vpdn enable

vpdn-group 1
accept dialin
protocol pppoe
virtual template 1
pppoe limit per-mac <number>

interface virtual-template 1
ip address 10.100.100.100 255.255.255.0
mtu 1492
```

For PPPoE virtual template interfaces, the **mtu** command must be configured because Ethernet has a maximum payload size of 1500 bytes, the PPPoE header is 6 bytes, and PPP Protocol ID is 2 bytes.



Note Dial-out mode will not be supported.

Enabling PPPoE on an Ethernet Interface Example

The following example enables PPPoE on an Ethernet interface:

```
interface ethernet1/0
pppoe enable
```

Additional References

The following sections provide references related to the PPPoE on Ethernet feature.

Related Documents

Related Topic	Document Title
Configuring PPPoE on ATM	PPPoE over ATM
Configuring PPPoE on cable interfaces	<ul style="list-style-type: none"> • Point-to-Point Protocol over Ethernet Support on the Cisco CMTS • Configuring PPPoE Termination on a uBR7100 CMTS with L2TP Tunneling
Configuring PPPoE on IEEE 802.1Q encapsulation	PPPoE Over IEEE 802.1Q VLANs

Standards

Standard	Title
No new or modified standards are supported by this feature, and support for existing standards has not been modified by this feature.	--

MIBs

MIB	MIBs Link
No new or modified MIBs are supported by this feature, and support for existing MIBs has not been modified by this feature.	To locate and download MIBs for selected platforms, Cisco IOS XE releases, and feature sets, use Cisco MIB Locator found at the following URL: http://www.cisco.com/go/mibs

RFCs

RFC	Title
RFC 2516	<i>A Method for Transmitting PPPoE</i>
RFC 4813	Multiprotocol Encapsulation over ATM Adaptation Layer 5

Technical Assistance

Description	Link
<p>The Cisco Support website provides extensive online resources, including documentation and tools for troubleshooting and resolving technical issues with Cisco products and technologies.</p> <p>To receive security and technical information about your products, you can subscribe to various services, such as the Product Alert Tool (accessed from Field Notices), the Cisco Technical Services Newsletter, and Really Simple Syndication (RSS) Feeds.</p> <p>Access to most tools on the Cisco Support website requires a Cisco.com user ID and password.</p>	<p>http://www.cisco.com/techsupport</p>

Feature Information for PPPoE on Ethernet

The following table provides release information about the feature or features described in this module. This table lists only the software release that introduced support for a given feature in a given software release train. Unless noted otherwise, subsequent releases of that software release train also support that feature.

Use Cisco Feature Navigator to find information about platform support and Cisco software image support. To access Cisco Feature Navigator, go to www.cisco.com/go/cfn. An account on Cisco.com is not required.

Table 33: Feature Information for PPPoE on Ethernet

Feature Name	Releases	Feature Information
PPPoE on Ethernet	Cisco IOS XE Release 2.5	<p>This feature was introduced on Cisco ASR 1000 Series Aggregation Services Routers.</p> <p>The PPPoE on Ethernet feature adds support to Point-to-Point Protocol over Ethernet (PPPoE) by adding direct connection to actual Ethernet interfaces. PPPoE provides service-provider digital subscriber line (DSL) support. This Ethernet specification can be used by multiple hosts on a shared Ethernet interface to open PPP sessions to multiple destination with one or more bridging modems.</p>



PPPoE over VLAN Enhancements Configuration Limit Removal and ATM Support

The PPPoE over VLAN Enhancements: Configuration Limit Removal and ATM Support feature provides two enhancements to PPP over Ethernet (PPPoE) over IEEE 802.1Q VLAN functionality:

- It removes the requirement for each PPPoE VLAN to be created on a subinterface. Removal of this requirement increases the number of VLANs that can be configured on a router to 4000 VLANs per interface.
- It adds ATM permanent virtual circuit (PVC) support for PPPoE over VLAN traffic that uses bridged RFC 1483 encapsulation.
- [Finding Feature Information, page 297](#)
- [Restrictions for PPPoE over VLAN Enhancements Configuration Limit Removal and ATM Support, page 298](#)
- [Information About PPPoE over VLAN Configuration Limit Removal and ATM Support, page 298](#)
- [How to Configure PPPoE over VLAN Enhancements Configuration Limit Removal and ATM Support, page 300](#)
- [Configuration Examples for PPPoE over VLAN Enhancements Configuration Limit Removal and ATM Support, page 304](#)
- [Additional References, page 305](#)
- [Feature Information for PPPoE over VLAN Enhancements Configuration Limit Removal and ATM Support, page 306](#)

Finding Feature Information

Your software release may not support all the features documented in this module. For the latest caveats and feature information, see [Bug Search Tool](#) and the release notes for your platform and software release. To find information about the features documented in this module, and to see a list of the releases in which each feature is supported, see the feature information table.

Use Cisco Feature Navigator to find information about platform support and Cisco software image support. To access Cisco Feature Navigator, go to www.cisco.com/go/cfn. An account on Cisco.com is not required.

Restrictions for PPPoE over VLAN Enhancements Configuration Limit Removal and ATM Support

- PPPoE over IEEE 802.1Q VLAN support can be configured without using subinterfaces on the PPPoE server only.
- ATM PVC support for PPPoE over IEEE 802.1Q VLANs can be configured only on the PPPoE server.
- It is not possible to shut down traffic for individual VLANs that are configured on the main interface. Individual VLANs that are configured on subinterfaces can be shut down.
- A VLAN range can be configured on a main interface at the same time that VLANs outside the range are configured on subinterfaces of the same main interface. However, you cannot configure a specific VLAN on the main interface and on a subinterface at the same time.
- PPPoE over VLAN Configuration on an interface is only supported for sessions that do not have Interface Descriptor Block (IDB). So this is not supported on ASR 1000 platforms.

Information About PPPoE over VLAN Configuration Limit Removal and ATM Support

To configure PPPoE over IEEE 802.1Q VLAN support on an interface rather than a subinterface, and to configure ATM support for PPPoE over IEEE 802.1Q VLANs, you should understand the following concepts:

PPPoE over VLAN Configuration Without Using Subinterfaces

The PPPoE over VLAN Enhancements: Configuration Limit Removal and ATM Support feature removes the requirement for each PPPoE VLAN to be created on a subinterface. Allowing more than one PPPoE VLAN to be configured on a main interface increases the number of VLANs that can be configured on a router to 4000 VLANs per interface.

Individual VLANs or a range of VLANs can be configured on an interface. You can configure a VLAN range on a main interface and at the same time configure VLANs outside the range on subinterfaces of the same interface.

PPPoE over VLAN Support on ATM PVCs

The PPPoE over VLAN Enhancements: Configuration Limit Removal and ATM Support feature enables ATM PVCs to process PPPoE over VLAN packets that use bridged RFC 1483 encapsulation. This capability allows PPPoE traffic from different IEEE 802.1Q VLANs to be multiplexed over the same ATM PVC.

The figure below shows a sample network topology that implements PPPoE over VLAN on ATM PVCs. In this topology, a service provider is using an Ethernet switch to provide Ethernet service to home users and a single PVC to provide the switch with WAN access. The home users use PPPoE to access services on the network access server (NAS). Each port on the switch is assigned a separate VLAN, and the VLANs are trunked over a Fast Ethernet or Gigabit Ethernet interface that is connected to a digital subscriber line (DSL) modem acting as a bridge.

The IEEE 802.1Q VLAN-encapsulated traffic coming in from the Ethernet switch trunk is encapsulated in RFC 1483 bridged encapsulation by the DSL modem and sent across the ATM WAN to the NAS. The NAS, which is configured to support PPPoE over VLANs over ATM PVCs, will extract the PPPoE packet from the PPPoE over IEEE 802.1Q VLAN over RFC 1483 bridged encapsulation and provide PPPoE services to the user.

In the downlink, the NAS sends packets in PPPoE over IEEE 802.1Q VLAN over RFC 1483 bridged encapsulation. The DSL modem strips off the RFC 1483 encapsulation and forwards the IEEE 802.1Q VLAN packets across the trunk to the switch. The switch then sends the Ethernet packets to the port associated with the IEEE 802.1 VLAN ID.

Figure 19: Sample Network Topology for PPPoE over IEEE 802.1Q VLANs over ATM

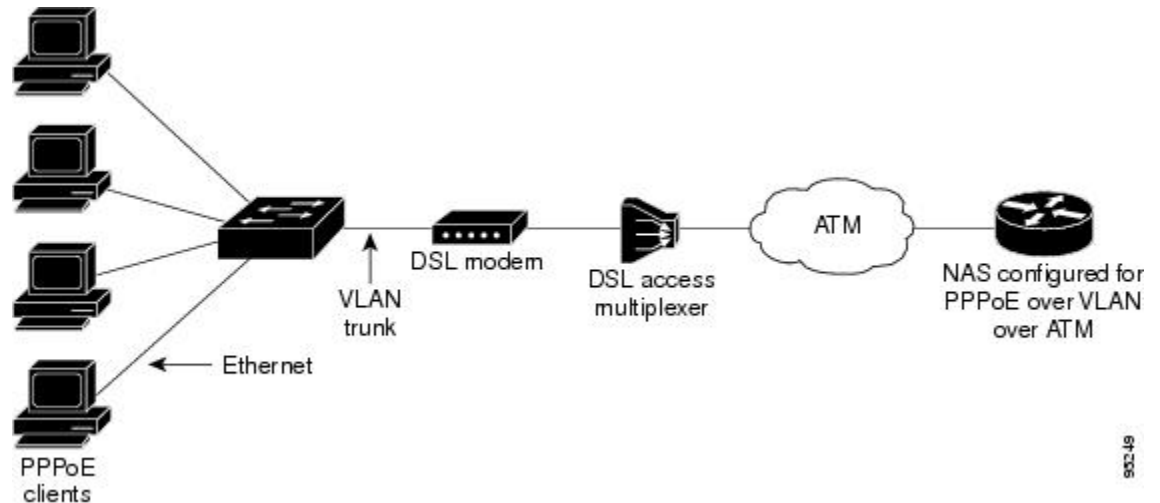

87-326

Benefits of PPPoE over VLAN Enhancements Configuration Limit Removal and ATM Support

The PPPoE over VLAN Enhancements: Configuration Limit Removal and ATM Support feature has the following benefits:

- Increases the number of VLANs that can be configured on a router to 4000 VLANs per interface by removing the requirement for each PPPoE VLAN to be configured on a subinterface.
- Provides support for PPPoE over VLANs over ATM interfaces using RFC 1483 bridged encapsulation

How to Configure PPPoE over VLAN Enhancements Configuration Limit Removal and ATM Support

Configuring PPPoE over IEEE 802.1Q VLAN Support on an Ethernet Interface

Perform this task to configure PPPoE over IEEE 802.1Q VLAN support on an Ethernet interface.

SUMMARY STEPS

1. **enable**
2. **configure terminal**
3. **interface** *type number*
4. Do one of the following:
 - **vlan-id dot1q** *vlan-id*
 -
 - **vlan-range dot1q** *start-vlan-id end-vlan-id*
5. **pppoe enable** [**group** *group-name*]

DETAILED STEPS

	Command or Action	Purpose
Step 1	enable Example: Router> enable	Enables privileged EXEC mode. <ul style="list-style-type: none"> • Enter your password if prompted.
Step 2	configure terminal Example: Router# configure terminal	Enters global configuration mode.
Step 3	interface <i>type number</i> Example: Router(config)# interface fastethernet 0/2	Specifies the interface to be configured and enters interface configuration mode.
Step 4	Do one of the following: <ul style="list-style-type: none"> • vlan-id dot1q <i>vlan-id</i> • 	Enables IEEE 802.1Q VLAN encapsulation for a specific VLAN on an Ethernet interface. or

	Command or Action	Purpose
	<ul style="list-style-type: none"> • <code>vlan-range dot1q start-vlan-id end-vlan-id</code> <p>Example:</p> <pre>Router(config-if)# vlan-id dot1q 0</pre> <p>Example:</p> <pre>Router(config-if)# vlan-range dot1q 0 60</pre>	Enables IEEE 802.1Q VLAN encapsulation for a range of VLANs on an Ethernet interface.
Step 5	<p><code>pppoe enable [group group-name]</code></p> <p>Example:</p> <pre>Router(config-if-vlan-range)# pppoe enable group pppoel</pre>	Enables PPPoE sessions over a specific VLAN or a range of VLANs.

Configuring an ATM PVC to Support PPPoE over IEEE 802.1Q VLAN Traffic

Perform this task to configure an ATM PVC to support RFC 1483 bridge encapsulated PPPoE over IEEE 802.1Q VLAN traffic.

SUMMARY STEPS

1. `enable`
2. `configure terminal`
3. `interface atm number . subinterface-number {multipoint | point-to-point}`
4. `pvc [name] vpi / vci`
5. `protocol pppovlan dot1q {vlan-id | start-vlan-id end-vlan-id} [group group-name]`

DETAILED STEPS

	Command or Action	Purpose
Step 1	<p><code>enable</code></p> <p>Example:</p> <pre>Router> enable</pre>	<p>Enables privileged EXEC mode.</p> <ul style="list-style-type: none"> • Enter your password if prompted.

	Command or Action	Purpose
Step 2	configure terminal Example: Router# configure terminal	Enters global configuration mode.
Step 3	interface atm <i>number</i> . <i>subinterface-number</i> {multipoint point-to-point} Example: Router(config)# interface atm 2/0.1 multipoint	Configures an ATM multipoint subinterface and enters subinterface configuration mode.
Step 4	pvc [<i>name</i>] <i>vpi</i> / <i>vci</i> Example: Router(config-subif)# pvc 0/60	Configures a PVC and enters ATM VC configuration mode.
Step 5	protocol pppovlan dot1q {<i>vlan-id</i> <i>start-vlan-id</i> <i>end-vlan-id</i>} [group <i>group-name</i>] Example: Router(config-if-atm-vc)# protocol pppovlan dot1q 0 50 group pppoe1	Enables PPPoE for a specific IEEE 802.1Q VLAN or a range of VLANs on an ATM PVC.

Configuring a VC Class for PPPoE over IEEE 802.1Q VLAN Support

Perform this task to configure support for PPPoE over IEEE 802.1Q VLANs in a VC class.

SUMMARY STEPS

1. **enable**
2. **configure terminal**
3. **vc-class atm *name***
4. **protocol pppovlan dot1q {*vlan-id* | *start-vlan-id* *end-vlan-id*}** [**group *group-name***]

DETAILED STEPS

	Command or Action	Purpose
Step 1	enable	Enables privileged EXEC mode.

	Command or Action	Purpose
	<p>Example:</p> <pre>Router> enable</pre>	<ul style="list-style-type: none"> Enter your password if prompted.
Step 2	<p>configure terminal</p> <p>Example:</p> <pre>Router# configure terminal</pre>	Enters global configuration mode.
Step 3	<p>vc-class atm name</p> <p>Example:</p> <pre>Router(config)# vc-class atm class1</pre>	Configures an ATM VC class and enters VC-class configuration mode.
Step 4	<p>protocol pppovlan dot1q {vlan-id start-vlan-id end-vlan-id} [group group-name]</p> <p>Example:</p> <pre>Router(config-vc-class)# protocol pppovlan dot1q 0 50 group pppoe1</pre>	<p>Enables support for PPPoE for a specific IEEE 802.1Q VLAN or a range of VLANs in a VC class.</p> <p>Note A VC class can be applied to an ATM interface, subinterface, PVC, or range of PVCs.</p>

Monitoring and Maintaining PPPoE over IEEE 802.1Q VLAN

Perform this task to monitor and maintain PPPoE over VLAN connections.

SUMMARY STEPS

- enable**
- clear pppoe** {interface type number [vc {[vpi/]vci | vc-name}] [vlan vlan-id] | rmac mac-address [sid session-id] | all}
- debug pppoe** {data | errors | events | packets} [rmac remote-mac-address | interface type number [vc {[vpi/]vci | vc-name}] [vlan vlan-id]]

DETAILED STEPS

	Command or Action	Purpose
Step 1	<p>enable</p> <p>Example:</p> <pre>Router> enable</pre>	<p>Enables privileged EXEC mode.</p> <ul style="list-style-type: none"> Enter your password if prompted.

	Command or Action	Purpose
Step 2	<p>clear pppoe {<i>interface type number</i> [<i>vc</i> {[<i>vpi</i>]/<i>vci</i> <i>vc-name</i>]}] [<i>vlan vlan-id</i>] <i>rmac mac-address</i> [<i>sid session-id</i>] all}</p> <p>Example:</p> <pre>Router# clear pppoe interface fastethernet 0/2 vlan 1</pre>	Clears PPPoE sessions.
Step 3	<p>debug pppoe {<i>data</i> <i>errors</i> <i>events</i> <i>packets</i>} [<i>rmac remote-mac-address</i> <i>interface type number</i>{<i>vc</i> {[<i>vpi</i> /]<i>vci</i> <i>vc-name</i>}}] [<i>vlan vlan-id</i>]]</p> <p>Example:</p> <pre>Router# debug pppoe events interface atm 0/0 vc 1/16 vlan 10</pre>	Displays debugging information for PPPoE sessions.

Configuration Examples for PPPoE over VLAN Enhancements Configuration Limit Removal and ATM Support

Configuring PPPoE over IEEE 802.1Q VLAN Support on an Ethernet Interface Example

The following example shows how to configure PPPoE over a range of IEEE 802.1Q VLANs on Fast Ethernet interface 0/0. The VLAN range is configured on the main interface and therefore each VLAN will not use up a separate subinterface.

```
bba-group pppoe PPPOE
 virtual-template 1
  sessions per-mac limit 1
 interface virtual-template 1
  ip address 10.10.10.10 255.255.255.0
  mtu 1492
 interface fastethernet 0/0
  no ip address
  no ip mroute-cache
  duplex half
  vlan-range dot1q 20 30
  pppoe enable group PPPOE
  exit-vlan-config
```

Configuring PPPoE over IEEE 802.1Q VLAN Support on ATM PVCs Example

The following example shows how to configure an ATM PVC to support PPPoE over a range of IEEE 802.1Q VLANs:

```
bba-group pppoe PPPOEOA
```



```
virtual-template 1
sessions per-mac limit 1
interface virtual-template 1
ip address 10.10.10.10 255.255.255.0
mtu 1492
interface atm 4/0.10 multipoint
pvc 10/100
protocol pppovlan dot1q range 10 30 group PPPOEOA
```

Additional References

The following sections provide references related to the PPPoE Over VLAN Enhancements: Configuration Limit Removal and ATM Support feature.

Related Documents

Related Topic	Document Title
ATM PVC configuration	ATM chapter of the Cisco IOS Wide-Area Networking Configuration Guide
PPPoE and PPPoE over IEEE 802.1Q VLAN configuration	Broadband Access: PPP and Routed Bridge Encapsulation chapter of the Cisco IOS Wide-Area Networking Configuration Guide
VLAN range configuration (using subinterfaces)	VLAN Range feature module
ATM PVC and PPPoE configuration commands	Cisco IOS Wide-Area Networking Command Reference

Standards

Standard	Title
IEEE Standard 802.1Q, 1998	<i>Virtual Bridged Local Area Networks</i>

MIBs

MIB	MIBs Link
No new or modified MIBs are supported by this feature, and support for existing MIBs has not been modified by this feature.	To locate and download MIBs for selected platforms, Cisco IOS releases, and feature sets, use Cisco MIB Locator found at the following URL: http://www.cisco.com/go/mibs

RFCs

RFC	Title
RFC 1483	<i>Multiprotocol Encapsulation over ATM Adaptation Layer 5</i>

Technical Assistance

Description	Link
<p>The Cisco Support website provides extensive online resources, including documentation and tools for troubleshooting and resolving technical issues with Cisco products and technologies.</p> <p>To receive security and technical information about your products, you can subscribe to various services, such as the Product Alert Tool (accessed from Field Notices), the Cisco Technical Services Newsletter, and Really Simple Syndication (RSS) Feeds.</p> <p>Access to most tools on the Cisco Support website requires a Cisco.com user ID and password.</p>	http://www.cisco.com/techsupport

Feature Information for PPPoE over VLAN Enhancements Configuration Limit Removal and ATM Support

The following table provides release information about the feature or features described in this module. This table lists only the software release that introduced support for a given feature in a given software release train. Unless noted otherwise, subsequent releases of that software release train also support that feature.

Use Cisco Feature Navigator to find information about platform support and Cisco software image support. To access Cisco Feature Navigator, go to www.cisco.com/go/cfn. An account on Cisco.com is not required.

Table 34: Feature Information for PPPoE over VLAN Enhancements: Configuration Limit Removal and ATM Support

Feature Name	Releases	Feature Information
PPPoE over VLAN Enhancements: Configuration Limit Removal and ATM Support	12.2 (31)SRC 12.3(2)T 12.2(33)SB Cisco IOS Release XE 3.9S	<p>The PPPoE over VLAN Enhancements: Configuration Limit Removal and ATM Support feature provides two enhancements to PPP over Ethernet (PPPoE) over IEEE 802.1Q VLAN functionality:</p> <ul style="list-style-type: none"> • It removes the requirement for each PPPoE VLAN to be created on a subinterface. Removal of this requirement increases the number of VLANs that can be configured on a router to 4000 VLANs per interface. • It adds ATM permanent virtual circuit (PVC) support for PPPoE over VLAN traffic that uses bridged RFC 1483 encapsulation. <p>In Cisco IOS Release 12.2(31)SRC, this feature was introduced.</p> <p>In Cisco IOS Release 12.3(2)T, this feature was integrated into the T train.</p> <p>In Cisco IOS Release 12.2(33)SB, support was added for the Cisco IOS 10000 series routers.</p> <p>The following commands were introduced or modified:</p> <p>clear pppoe , debug pppoe, pppoe enable, protocol pppovlan dot1q, vlan-id dot1q, vlan-range dot1q.</p>



Configuring PPPoE over L2TPv3 Tunnels

The Layer 2 Tunneling Protocol Version 3 (L2TPv3) defines the L2TP protocol for tunneling Layer 2 payloads over an IP core network. In this feature, PPPoE packets are transported between network sites. The IP packets carry L2TP data messages and PPPoE sessions terminate on a Broadband Network Gateway (BNG) instead of at each Point of Presence (PoP). This feature allows you to extract and terminate PPP sessions for incoming traffic encapsulated in L2TPv3 IPv6 tunnels.

- [Information About Configuring PPPoE over L2TPv3 Tunnels, page 309](#)
- [How to Configure PPPoE over L2TPv3 Tunnels, page 315](#)
- [Additional References for Configuring PPPoE over L2TPv3 Tunnels, page 333](#)
- [Feature Information for Configuring PPPoE over L2TPv3 Tunnels, page 334](#)

Information About Configuring PPPoE over L2TPv3 Tunnels

Overview of PPPoE over L2TPv3 Tunnels

The PPPoE over L2TPv3 feature allows you to establish PPPoE sessions for incoming traffic using Layer 2 Tunneling Protocol Version 3 (L2TPv3) IPv6 tunnels. An L2TPv3 over IPv6 tunnel is a static/stateless P2P overlay tunnel between a physical edge/aggregation router and its peer entity. The peer entity is typically a virtual Broadband Network Gateway (vBNG), Virtual Network Function (VNF). The L2TPv3 tunnel transports ethernet traffic to and from CPEs. Each CPE is connected to an Access Node Optical Line Terminal (OLT)/Digital Subscriber Line Access Multiplexer (DSLAM).

Point-to-Point Protocol over Ethernet (PPPoE)—protocol describing the encapsulation of PPP frames inside ethernet frames and tunneling packets over Digital Subscriber Lines (DSLs) to Internet Service Providers (ISPs).

L2TPv3 Tunnel Interface—logical interface for terminating Broadband Subscriber Layer 2 Ethernet attachment circuits (port/VLAN) from access or edge routers over an IPv6 network with L2TPv3 encapsulation for BNG services. For further information, see IETF [RFC8159](#).

The difference between the situation before and after the introduction of PPPoE sessions for L2TPv3 tunnels is shown in Figures 1 and 2 in: [Overview of PPPoE over L2TPv3 Tunnels—Example Topology, on page 310](#).

You can use Point-to-Point Protocol over Ethernet (PPPoE) sessions via EoL2TPv3oIPv6 tunnels to deliver the same functions as those described in: [How to Enable and Configure PPPoE on Ethernet](#).

The PPPoE sessions used by this feature have the following key characteristics:

- H-QoS shaper per-session
- In/Out Access Control Lists (ACLs)
- Dual Stack
- Ingress QoS Policing
- Unicast Reverse Path Forwarding (uRPF)
- Lawful Intercept (LI)—both Radius & SNMP-based
- Session termination in VRF

The scope of a vBNG on a static/stateless P2P EoL2TPv3oIPv6 overlay tunnel includes:

- An EoL2TPv3oIPv6 overlay tunnel with and without VLAN tags:
 - Plain ethernet traffic OR
 - Dot1Q (Single VLAN tagged)
- All applicable features/functionality that are currently supported on physical interfaces for PPPoE sessions:
 - PTA (locally terminated) or LAC (forwarded to LNS over L2TPv2oIPv4)
 - IPv4 IPoE session (**Note:** IPv4 only)
 - Session authentication/authorization, policy enforcement, accounting and an AAA/RADIUS interface. These all function in the same way as currently supported on physical interfaces for PPPoE sessions
 - Only session-level QoS—as currently supported for PPPoE sessions.
 - For PPPoE PTA sessions:
 - Per-session in and out ACLs
 - VRF mapping

Overview of PPPoE over L2TPv3 Tunnels—Example Topology

The effect of using this feature can be simply shown by looking at example topologies before and after this feature was introduced. Figure 1 shows an example topology using a traditional BNG architecture. This

example uses two BNGs for three CPEs. Figure 2 shows an example of the BNG architecture using this feature, which only uses one vBNG for three CPEs.

Figure 20: Traditional BNG Architecture

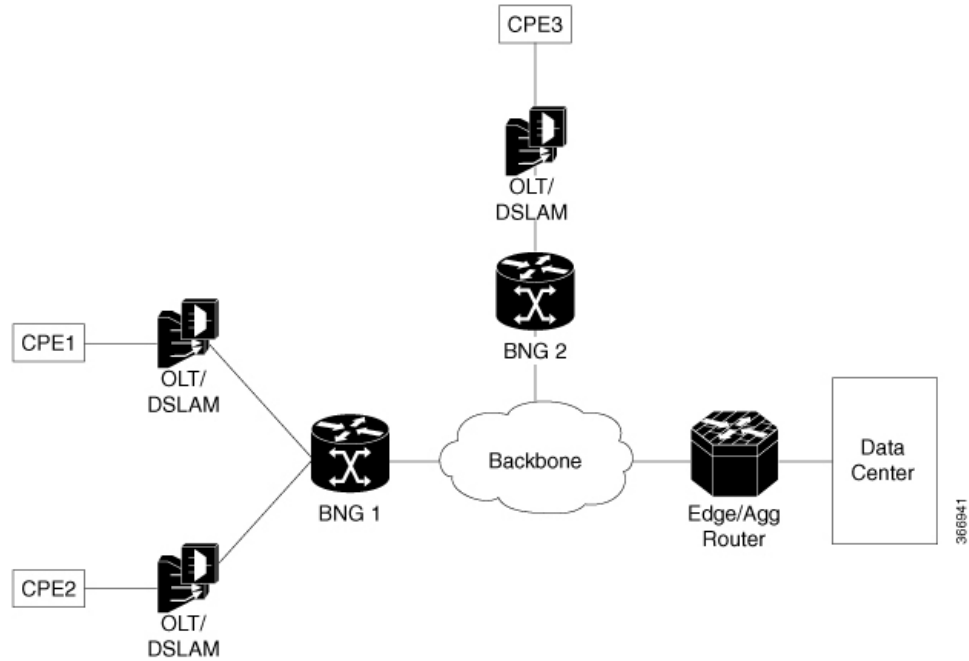
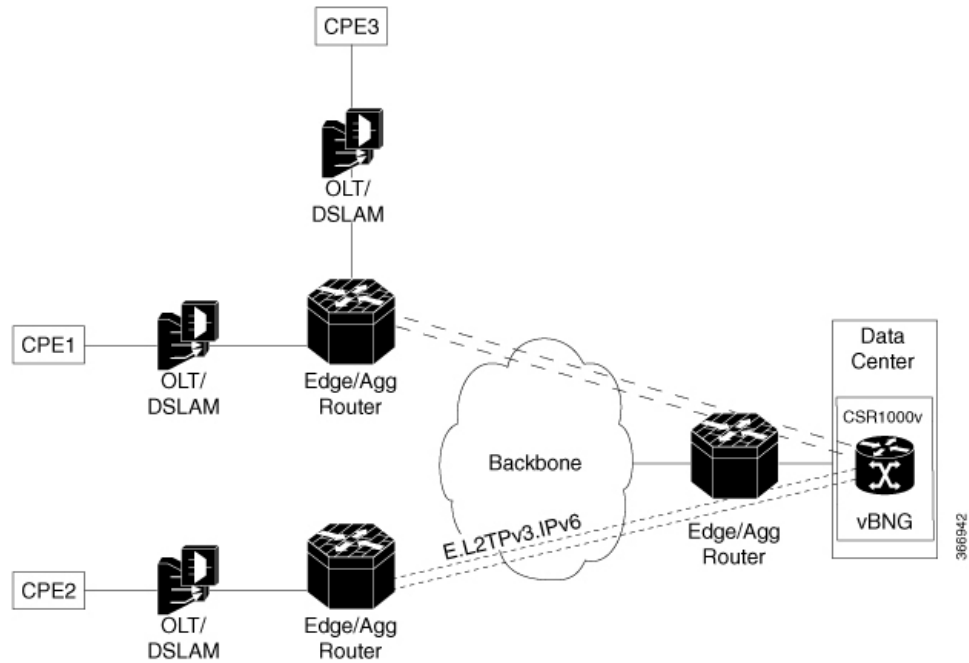

Figure 21: PPPoE over L2TPv3 Tunnels to vBNG



Benefits of PPPoE over L2TPv3 Tunneling

A benefit of this feature is that a Broadband Network Gateway(BNG) can be placed in each data center, instead of at each point of presence(PoP). An ISP can use L2TPv3 tunneling to send dual-stack PPP packets across its own IPv6 backbone network for a PPP Terminated Aggregation (PTA) session or a L2TP Access Concentrator (LAC) session.

Prerequisites for PPPoE over L2TPv3 Tunnels

Software Prerequisites:

- Currently only supported on a Cisco CSR 1000v VM. This virtual router requires at least 2 CPUs, 8GB RAM or above, and 2 or more (vNIC) interfaces (10Gb).

Restrictions for Configuring PPPoE over L2TPv3 Tunnels

- Q-in-Q tunneling is not supported
- Tunnel H-QoS is not supported
- Access Node Control Protocol (ANCP) is not supported
- IPoE sessions are not supported (only PPPoE sessions are supported)
- Netconf/Yang Model is not supported
- We recommend using a physical interface/subinterface as the tunnel source instead of a loopback interface, to support session-level QoS Queuing or Shaping
- High Availability (HA) is not supported
- This feature does not support any PPPoE feature under the tunnel interface except for PPPoE enable function.
- A VLAN range under the tunnel is not supported
- MIB is not supported
- The size of the secondary local cookie must equal the size of the primary local cookie
- If a PPPoE session is up, the following actions are not allowed:
 - Removal of the tunnel mode
 - Removal of remote cookies
 - Modification or removal of tunnel parameters is not allowed, but removal of local cookies is allowed.

Scaling of L2P2TPv3 Tunnels

Performance of Cisco CSR 1000v

The scaling and throughput for vBNG on the Cisco CSR 1000v depends upon the compute Node platform and Operating System, including the hypervisor and vRouter. An example specification and the resulting performance, are described below,

Specification—An Intel x86 server platform consisting of a compute node running vBNG instances (Cisco CSR 1000v VMs) with 2 sockets (14 cores per socket), 4 x 10G NICs, a CPU of 2.30 GHz E5-2658 v4/105W 14C/35MB Cache/DDR4 2400MHz. A Linux Ubuntu 14.04 host OS with KVM Hypervisor (QEMU Rx & Tx size=1024) and a vSwitch (DPDK & vhost-user interface to the Cisco CSR 1000v VM). Note: We highly recommend using vCPU pinning for the Cisco CSR 1000v VMs and emulator, because large 1 GB pages are required for Cisco CSR 1000v VMs and the host OS.

Performance—8000 sessions (PPPoE) across 40 static/stateless P2P EoL2TPv3oIPv6 tunnels, with an average of 200 sessions per tunnel, a total throughput (UL + DL) of 4 Gbps. A vNIC with 2 x 10G ports: one port is for DL (to/from Edge/Aggregation router) and another port for UL (to/from core network).

The following table shows the relationship between the number of tunnels and the number of PTA or LAC sessions per tunnel.

Table 35: Scaling for L2TPv3 Tunnels: Cisco CSR 1000v

No. of L2TPv3 over IPv6 Tunnels	PTA sessions per tunnel Single or Dual Stack	LAC sessions per tunnel Single or Dual Stack	PTA + LAC Sessions per tunnel Single or Dual Stack
40	200		
40		200	
40			200 PTA (in 30 tunnels) and 200 LAC (in 10 tunnels)

Call Flows for PPPoE over L2TPv3oIPv6 Tunnels

The figure below summarizes the call flows for PPPoE over an L2TPv3oIPv6 tunnel. Call flows are also explained here: [PPP and L2TP Flow Summary](#). For Cisco IOS XE Fuji 16.7, PPPoE is supported. (IPoE is

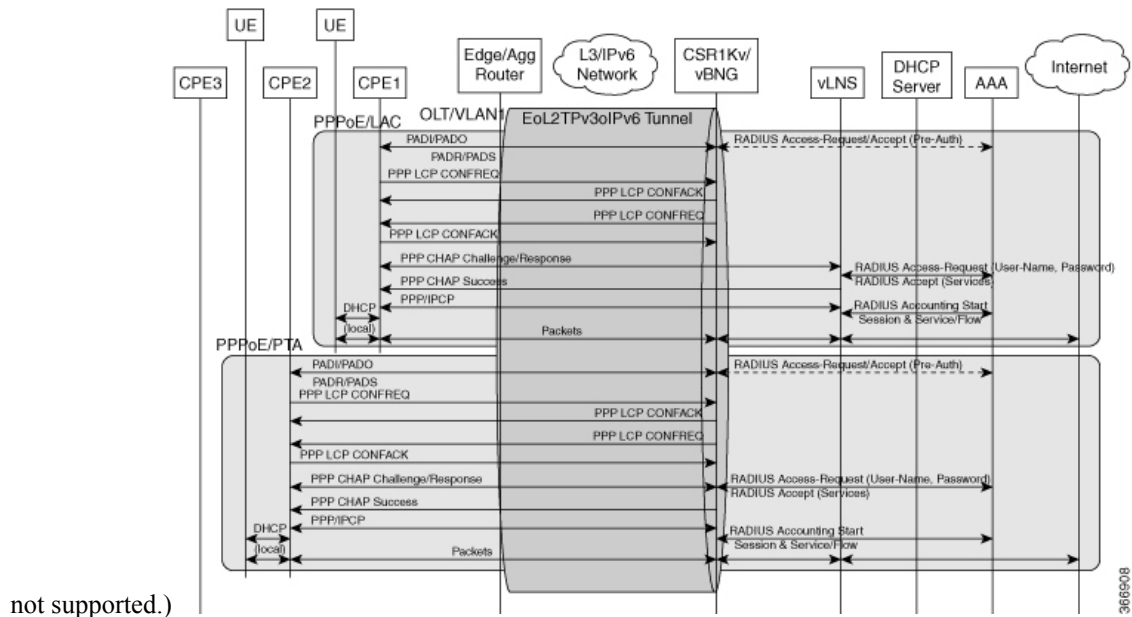

NAS-Port-Type Extensions

The following extended NAS-Port-Types are currently defined for a PPPoE service on ethernet and ATM interfaces.

- PPPoA—Radius value 30
- PPPoEoA—Radius value 31
- PPPoEoE—Radius value 3
- PPPoEoVLAN—Radius value 33
- PPPoEoQinQ—Radius value 34

In this feature, PPPoE support is added to the virtual interface (tunnel), which requires a new NAS-Port-Type for the PPPoE service on a virtual interface.

The following extended NAS-Port-Types were introduced for RFC2516, and which support the PPPoE service on virtual interfaces are supported:

- VirtualPPPoEoE (PPP over Ethernet [RFC2516] over Ethernet over tunnel/pseudowire) – Radius Value 44
- VirtualPPPoEoVLAN (PPP over Ethernet [RFC2516] over VLAN tunnel/pseudowire) – Radius Value 45

(The following extended NAS-Port-Type, introduced for RFC2516, is not supported: VirtualPPPoEoQinQ (PPP over Ethernet [RFC2516] over IEEE 802.1QinQ tunnel/pseudowire) – Radius Value 46.)

Network Topology Overview

Figure 3 below is an overview of the network topology. Traffic from CPE1 and CPE2 uses PPPoE sessions and EoL2TPv3oIPv6 tunnels to a vBNG in the data center. For each OLT/VLAN, a static EoL2TPv3oIPv6 tunnel is provisioned between an Edge or Aggregation Router and the vBNG on a Cisco CSR 1000v. The Edge/Agg Router forwards ethernet traffic from CPEs through EoL2TPv3oIPv6 tunnels.

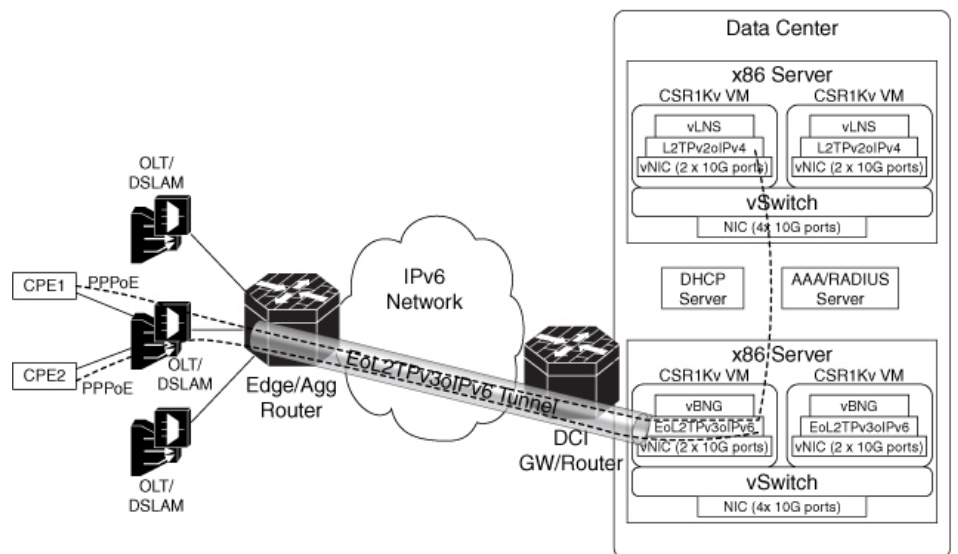

How to Configure PPPoE over L2TPv3 Tunnels

Overview of Configuring PPPoE over L2TPv3 Tunnels

To configure PPPoE over L2TPv3 tunnels perform the following configuration tasks:

- [Configuring the Edge Router for PPPoE over L2TPv3 Tunneling](#)
- [Configuring the vSwitch, on page 318](#)
- [Verifying the vSwitch, on page 321](#)
- [Configuring Radius Authentication for PPPoE over L2TPv3 Tunnels, on page 323](#)
- [Configuring vBNG on the Cisco CSR 1000v VM](#)
- [Configuring PPPoE over an L2TPv3 Tunnel on the Cisco CSR 1000v](#)
- [Verifying PPPoE Sessions, on page 326](#)
- [Verifying PPPoE over L2TPv3 Tunnels, on page 329](#)
- [Troubleshooting PPPoE over L2TPv3 Tunnels, on page 333](#)

Configuring the Edge Router for PPPoE over L2TPv3 Tunneling

The following example shows the configuration of the edge router (for example, a Cisco ASR 9000) at the start of the L2TPv3 tunnel that extends from this router through the backbone network to an x86 server in the data center.

```
RP/0/RSP0/CPU0:ASR9K# show running-configuration

Thu Oct 19 02:04:51.459 UTC
Building configuration...
!! IOS XR Configuration 5.1.1.11I
!! Last configuration change at Thu Oct 12 15:29:01 2017 by lab
!
hostname ASR9K
logging console debugging
logging buffered 10000000
tftp vrf default ipv4 server homedir disk0:
cdp
cdp log adjacency changes
cdp advertise v1
line console
  timeout login response 0
  exec-timeout 0 0
  stopbits 1
  session-timeout 0
!
onep
!
tftp client source-interface MgmtEth0/RSP0/CPU0/0
ipv4 access-list 1
  10 permit ipv4 30.1.1.0/24 any
!
interface MgmtEth0/RSP0/CPU0/0
  cdp
  ipv4 address 9.45.102.62 255.255.0.0
!
interface MgmtEth0/RSP0/CPU0/1
  cdp
  shutdown
!
interface TenGigE0/0/0/0
  ipv4 address 10.1.1.2 255.255.255.0
  transceiver permit pid all
!
interface TenGigE0/0/0/0.401 l2transport
  encapsulation dot1q 401
!
interface TenGigE0/0/0/0.402 l2transport
  encapsulation dot1q 402
!
<for brevity, the interface commands from
interface TenGigE0/0/0/0.403 l2transport
to
interface TenGigE0/0/0/0.440 l2transport
have been removed>

interface TenGigE0/0/0/1
  ipv4 address 20.1.1.1 255.255.255.0
  ipv6 address 1111:2222::abcd/64
  ipv6 enable
  transceiver permit pid all
!
interface TenGigE0/0/0/2
  ipv4 address 30.1.1.2 255.255.255.0
!
interface TenGigE0/0/0/3
  ipv4 address 40.1.1.1 255.255.255.0
!
```

```

interface preconfigure GigabitEthernet0/0/0/12
  ipv4 address 1.1.2.13 255.255.255.0
  shutdown
  transceiver permit pid all
!
interface preconfigure GigabitEthernet0/0/0/13
  ipv4 address 1.1.2.14 255.255.255.0
  shutdown
  transceiver permit pid all
!
<for brevity, some interface commands have been removed>

interface preconfigure GigabitEthernet0/0/0/19
  description test
  ipv4 address 2.2.2.5 255.255.255.0
  shutdown
  transceiver permit pid all
!
interface preconfigure GigabitEthernet0/0/1/0
  ipv4 address 1.1.2.20 255.255.255.0
  shutdown
  transceiver permit pid all
!
interface preconfigure GigabitEthernet0/0/1/1
  description test-pub-sub
  ipv4 address 1.1.2.21 255.255.255.0
  shutdown
  transceiver permit pid all
!
interface preconfigure GigabitEthernet0/0/1/2
  ipv4 address 1.1.2.22 255.255.255.0
  shutdown
  transceiver permit pid all
!
<for brevity, some interface commands have been removed>

interface preconfigure GigabitEthernet0/0/1/19
  ipv4 address 10.64.67.24 255.255.255.0
  shutdown
  transceiver permit pid all
!
interface preconfigure GigabitEthernet0/1/0/0
  service-policy input ariadne
  service-policy output ariadne
  ipv4 address 1.1.1.1 255.255.255.0
  ipv4 access-group ariadne-demo-phase2 ingress
!
interface preconfigure GigabitEthernet0/1/0/1
  ipv4 address 10.2.2.5 255.255.255.0
  shutdown
!
interface preconfigure GigabitEthernet0/1/0/2
  ipv4 address 10.3.3.5 255.255.255.0
!
interface preconfigure GigabitEthernet0/1/0/3
  ipv4 address 10.4.4.5 255.255.255.0
!
interface preconfigure GigabitEthernet0/1/0/4
  shutdown
!
<for brevity, the interface configuration commands from
interface preconfigure GigabitEthernet0/1/0/4
to
interface preconfigure GigabitEthernet0/2/1/19
have been removed>

shutdown
!
router static
  address-family ipv4 unicast

```

```

1.1.0.0/16 30.1.1.1
10.64.67.0/24 40.1.1.2
50.1.1.0/24 40.1.1.2
202.153.144.25/32 9.45.0.1
!
address-family ipv6 unicast
1111:2222::cdef/128 TenGigE0/0/0/1
!
!
l2vpn
pw-class test
  encapsulation l2tpv3
  protocol l2tpv3
!
!
xconnect group test1
  p2p test1
  interface TenGigE0/0/0/0.401
  neighbor ipv6 1111:2222::cdef pw-id 1
  pw-class test1
  source 1111:1101::abcd
  l2tp static
    local cookie size 8 value 0x4 0x4
    local session 1
    remote cookie size 8 value 0x4 0x4
    remote session 1
  !
!
!
<for brevity, the commands from
xconnect group test2
to
xconnect group test40
have been removed>

```

Configuring the vSwitch

To configure a Vector Packet Processing (VPP) vSwitch, which forwards L2TPv6 packets on the x86 server, edit the startup.conf file as shown in the following example. This allows the connection of physical NICs to vBNGs in the VMs.

```

root@vbnng:~# more /etc/vpp/startup.conf
unix {
  nodaemon
  cli-listen localhost:5002
  log /tmp/vpp.log
  full-coredump
}
cpu {
  ## In the VPP there is one main thread and optionally the user can create worker(s)

  ## The main thread and worker thread(s) can be pinned to CPU core(s) manually or
  automatically
  ## Manual pinning of thread(s) to CPU core(s)
  ## Set logical CPU core where main thread runs
  main-core 2
  ## Set logical CPU core(s) where worker threads are running
  corelist-workers 3,6
  ## Automatic pinning of thread(s) to CPU core(s)
  ## Sets number of CPU core(s) to be skipped (1 ... N-1)
  ## Skipped CPU core(s) are not used for pinning main thread and working thread(s).
  ## The main thread is automatically pinned to the first available CPU core and
worker(s)
  ## are pinned to next free CPU core(s) after core assigned to main thread
  # skip-cores 4
  ## Specify a number of workers to be created
  ## Workers are pinned to N consecutive CPU cores while skipping "skip-cores" CPU

```

```

core(s)
  ## and main thread's CPU core
  # workers 2
  ## Set scheduling policy and priority of main and worker threads
  ## Scheduling policy options are: other (SCHED_OTHER), batch (SCHED_BATCH)
  ## idle (SCHED_IDLE), fifo (SCHED_FIFO), rr (SCHED_RR)
  # scheduler-policy fifo
  ## Scheduling priority is used only for "real-time policies (fifo and rr),
  ## and has to be in the range of priorities supported for a particular policy
  # scheduler-priority 50
}
dpdk {
  ## Change default settings for all interfaces
  # dev default {
    ## Number of receive queues, enables RSS
    ## Default is 1
    # num-rx-queues 3
    ## Number of transmit queues, Default is equal
    ## to number of worker threads or 1 if no workers threads
    # num-tx-queues 3
    ## Number of descriptors in transmit and receive rings
    ## increasing or reducing number can impact performance
    ## Default is 1024 for both rx and tx
    # num-rx-desc 512
    # num-tx-desc 512
    ## VLAN strip offload mode for interface
    ## Default is off
    # vlan-strip-offload on
  # }
  ## Whitelist specific interface by specifying PCI address
  # dev 0000:02:00.0
  no-multi-seg
  socket-mem 8192,8192
  uio-driver igb_uio
  dev 0000:43:00.0
  dev 0000:43:00.1
  ## Whitelist specific interface by specifying PCI address and in
  ## addition specify custom parameters for this interface
  # dev 0000:02:00.1 {
    # num-rx-queues 2
  # }
  ## Change UIO driver used by VPP, Options are: igb_uio, vfio-pci
  ## and uio_pci_generic (default)
  # uio-driver vfio-pci
  ## Disable multi-segment buffers, improves performance but
  ## disables Jumbo MTU support
  # no-multi-seg
  ## Increase number of buffers allocated, needed only in scenarios with
  ## large number of interfaces and worker threads. Value is per CPU socket.
  ## Default is 16384
  # num-mbufs 128000
  ## Change hugepages allocation per-socket, needed only if there is need for
  ## larger number of mbufs. Default is 256M on each detected CPU socket
  # socket-mem 2048,2048
}
api-trace {
  on
}
api-segment {
  gid vpp
}
# Adjusting the plugin path depending on where the VPP plugins are:
#plugins
#{
# path /home/bms/vpp/build-root/install-vpp-native/vpp/lib64/vpp_plugins
#}
# Alternate syntax to choose plugin path
#plugin_path /home/bms/vpp/build-root/install-vpp-native/vpp/lib64/vpp_plugins
root@vbngr:~#

```

Telnet into VPP and check the interfaces:

```
root@gordian:~# telnet localhost 5002
Trying ::1...
Trying 127.0.0.1...
Connected to localhost.
Escape character is '^]'.
```

```
vpp#
vpp# show interfaces
```

Name	Idx	State	Counter	Count
TenGigabitEthernet48/0/0	1	down		
TenGigabitEthernet51/0/0	2	down		
local0	0	down		

```
vpp#
```

Configure VPP on the PPP to CSR 1000v side:

```
vpp# create vhost socket /tmp/vhost-user-vm1-int1
VirtualEthernet0/0/0
vpp#
vpp# set interface state VirtualEthernet0/0/0 up
vpp# set interface l2 bridge VirtualEthernet0/0/0 1

vpp# set interface state TenGigabitEthernet51/0/0 up
vpp# set interface l2 bridge TenGigabitEthernet51/0/0 2
vpp# create vhost socket /tmp/vhost-user-vm1-int2
VirtualEthernet0/0/1
vpp#
vpp# set interface state VirtualEthernet0/0/1 up
vpp# set interface l2 bridge VirtualEthernet0/0/1 2
```

Configure VPP on the backbone network side:

```
vpp# set interface state TenGigabitEthernet51/0/0 up
vpp# set interface l2 bridge TenGigabitEthernet51/0/0 2
vpp# create vhost socket /tmp/vhost-user-vm1-int2
VirtualEthernet0/0/1
vpp#
vpp# set interface state VirtualEthernet0/0/1 up
vpp# set interface l2 bridge VirtualEthernet0/0/1 2
```

Verify the vSwitch configuration using the `show interface` command as shown in the following example.

This includes an incoming physical interface (pNIC) on the x86 server TenGigabitEthernet43/0/0. The corresponding virtual interface on the vSwitch is VirtualEthernet0/0/0.

```
vpp# show interface
```

Name	Idx	State	Counter	Count
TenGigabitEthernet43/0/0	1	up	rx packets	3750503475
			rx bytes	3999648912124
			tx packets	6441344996
			tx bytes	7212168652537
			drops	66263
TenGigabitEthernet43/0/1	2	up	rx packets	8058785942
			rx bytes	8503746413545
			tx packets	3074652529
			tx bytes	2909632140685
			tx-error	49
VirtualEthernet0/0/0	3	up	rx packets	6441344996
			rx bytes	7212168652537
			tx packets	3750437212
			tx bytes	3999640288634
			drops	251663
VirtualEthernet0/0/1	4	up	tx-error	66263
			rx packets	3074652578
			rx bytes	2909632143625
			tx packets	8058785942
			tx bytes	8503746413545
drops	1460666			

```
local0                0                down
vpp#
```

Verifying the vSwitch

Perform the following `show running-configuration` command to verify the configurations that were previously made in [Configuring the vSwitch, on page 318](#).

```
vpp# show running-configuration
```

```
Thread 0 vpp_main (lcore 2)
Time 1340274.6, average vectors/node 0.00, last 128 main loops 0.00 per node 0.00
vector rates in 0.0000e0, out 0.0000e0, drop 0.0000e0, punt 0.0000e0
Name State Calls Vectors Suspend
Clocks Vectors/Call
acl-plugin-fa-cleaner-process event wait 0 0 1
3.83e4 0.00
admin-up-down-process event wait 0 0 1
1.60e4 0.00
api-rx-from-ring active 0 0 68709
1.82e4 0.00
bfd-process event wait 0 0 1
2.97e4 0.00
cdp-process any wait 0 0 478747
2.11e3 0.00
dhcp-client-process any wait 0 0 13401
1.13e4 0.00
dpdk-ipsec-process done 1 0 0
1.74e5 0.00
dpdk-process any wait 0 0 446669
4.05e5 0.00
fib-walk any wait 0 0 670044
4.35e3 0.00
flow-report-process any wait 0 0 1
2.52e4 0.00
flowprobe-timer-process any wait 0 0 1
6.17e4 0.00
gmon-process time wait 0 0 268018
4.33e3 0.00
ikev2-manager-process any wait 0 0 1340090
4.09e3 0.00
ioam-export-process any wait 0 0 1
4.51e4 0.00
ip6-icmp-neighbor-discovery-ev any wait 0 0 1340090
3.59e3 0.00
l2fib-mac-age-scanner-process event wait 0 0 1
1.51e4 0.00
lisp-retry-service any wait 0 0 670044
5.42e3 0.00
lldp-process event wait 0 0 1
2.71e6 0.00
memif-process event wait 0 0 1
2.59e5 0.00
nat64-expire-walk done 1 0 0
7.21e4 0.00
send-garp-na-process event wait 0 0 1
1.21e4 0.00
snat-det-expire-walk done 1 0 0
4.20e4 0.00
startup-config-process done 1 0 1
1.99e4 0.00
udp-ping-process any wait 0 0 1
7.34e4 0.00
unix-epoll-input polling 2516699421 0 0
1.17e6 0.00
vhost-user-process any wait 0 0 446683
1.09e4 0.00
vhost-user-send-interrupt-proc any wait 0 0 1
1.16e4 0.00
```

```

vpe-link-state-process      event wait      0          0          63
    5.59e3            0.00
vpe-oam-process            any wait      0          0        656907
    3.59e3            0.00
vpe-route-resolver-process any wait      0          0        13401
    1.09e4            0.00
vxlan-gpe-ioam-export-process any wait      0          0          1
    4.14e4            0.00
-----
Thread 1 vpp_wk_0 (lcore 3)
Time 1340274.6, average vectors/node 2.29, last 128 main loops 0.00 per node 0.00
vector rates in 7.6043e3, out 7.6042e3, drop 4.9439e-2, punt 0.0000e0
      Name          State      Calls      Vectors      Suspends
      Clocks      Vectors/Call
TenGigabitEthernet43/0/0-outpu active      1033884260  6441345157      0
    2.48e1            6.23
TenGigabitEthernet43/0/0-tx   active      1033884260  6441345157      0
    1.07e2            6.23
VirtualEthernet0/0/0-output  active      3477767073  3750503532      0
    1.06e2            1.08
VirtualEthernet0/0/0-tx      active      3477700818  3750437269      0
    1.84e3            1.08
dpdk-input                   polling     16272823442465  3750503532      0
    2.78e5            0.00
error-drop                   active      66255        66263            0
    1.17e2            1.00
ethernet-input               active      4429434865  10191848689     0
    9.61e1            2.30
12-flood                     active      81553        81594            0
    5.29e2            1.00
12-fwd                       active      4429356482  10191767095     0
    6.80e1            2.30
12-input                     active      4429434865  10191848689     0
    1.55e2            2.30
12-learn                     active      4429434865  10191848689     0
    6.60e1            2.30
12-output                    active      4429434865  10191848689     0
    5.48e1            2.30
vhost-user-input             polling     16252470346346  6441345157      0
    2.26e5            0.00
-----
Thread 2 vpp_wk_1 (lcore 6)
Time 1340274.6, average vectors/node 1.34, last 128 main loops 0.00 per node 0.00
vector rates in 8.3068e3, out 8.3068e3, drop 3.6559e-5, punt 0.0000e0
      Name          State      Calls      Vectors      Suspends
      Clocks      Vectors/Call
TenGigabitEthernet43/0/1-outpu active      633497566   3074652580      0
    3.73e1            4.85
TenGigabitEthernet43/0/1-tx   active      633497517   3074652531      0
    1.35e2            4.85
VirtualEthernet0/0/1-output  active      7749969518  8058785944      0
    1.23e2            1.04
VirtualEthernet0/0/1-tx      active      7749969518  8058785944      0
    1.69e3            1.04
dpdk-input                   polling     15572336805744  8058785944      0
    1.32e5            0.00
error-drop                   active      49           49              0
    6.62e2            1.00
ethernet-input               active      8294784335  11133438524     0
    1.17e2            1.34
12-flood                     active      142          142            0
    7.26e2            1.00
12-fwd                       active      8294784194  11133438382     0
    9.45e1            1.34
12-input                     active      8294784335  11133438524     0
    2.81e2            1.34
12-learn                     active      8294784335  11133438524     0
    1.65e2            1.34
12-output                    active      8294784335  11133438524     0
    8.25e1            1.34
vhost-user-input             polling     15552267493917  3074652580      0
    4.65e5            0.00

```

```
vpp#
```

Configuring Radius Authentication for PPPoE over L2TPv3 Tunnels

Configuring Radius Authentication for a PPP PTA Session

To configure Radius authentication for a PPP terminated aggregation (PTA) session, refer to a guide such as the [Radius Configuration guide](#). The following example shows a snippet of the code required for the authentication of the PPP PTA session.

```
pta@cisco.com Cleartext-Password := "cisco"
                Service-Type = Framed-user,
#               Cisco-Account-Info += "Asrl_down(r=500)",
#               Cisco-Account-Info += "Asrl_up(r=500,corr=20,si=1)",
                Cisco-Account-Info += "Asrl_down(r=200)",
#               Session-Timeout = 400,
                Cisco-Account-Info += "subscriber:accounting-list=List1",
                Cisco-Account-Info += "AACCT_SERVICE",
                Cisco-Account-Info += "AACCT_SERVICE_V6"
```

Configuring Radius Authentication for a PPP LAC Session

To configure Radius authentication for the L2TP Access Concentrator (LAC), refer to a RADIUS guide such as the [Radius Configuration guide](#). The following example shows a snippet of the code required for authentication of the LAC.

```
lacupsrl@cisco.com Cleartext-Password := "cisco"
                   Service-Type = Outbound-User,
                   cisco-AVPair += "vpdn:tunnel-id=CSR_TENGIG",
                   cisco-AVPair += "vpdn:l2tp-tunnel-password=cisco",
                   cisco-AVPair += "vpdn:tunnel-type=l2tp",
                   cisco-AVPair += "vpdn:ip-addresses=40.1.1.2",
#                   Session-Timeout = 600,
                   Cisco-Account-Info += "Asrl_up(r=500,corr=20,si=1)",
                   Cisco-AVPair += "ip:outacl=acct_out",
                   Cisco-Account-Info += "subscriber:accounting-list=List1"
```

Configuring vBNG on the Cisco CSR 1000v VM

Configure the XML configuration file for vBNG on the Cisco CSR 1000v VM as shown in the following example.

```
<domain type='kvm' id='21' xmlns:qemu='http://libvirt.org/schemas/domain/qemu/1.0'>
  <name>vbng</name>
  <uuid>7c0c20b3-b9b6-462c-a1e6-01d3efac0abe</uuid>
  <memory unit='KiB'>8388608</memory>
  <currentMemory unit='KiB'>8388608</currentMemory>
  <memoryBacking>
    <hugepages/>
  </memoryBacking>
  <vcpu placement='static'>28</vcpu>
  <os>
    <type arch='x86_64' machine='pc-i440fx-xenial'>hvm</type>
    <boot dev='hd' />
  </os>
  <features>
    <acpi/>
    <apic/>
  </features>
</domain>
```

```

</features>
<cpu mode='host-model'>
  <model fallback='allow'/>
  <topology sockets='2' cores='14' threads='1'/>
</cpu>
<clock offset='utc'>
  <timer name='rtc' tickpolicy='catchup'/>
  <timer name='pit' tickpolicy='delay'/>
  <timer name='hpet' present='no'/>
</clock>
<on_poweroff>destroy</on_poweroff>
<on_reboot>restart</on_reboot>
<on_crash>restart</on_crash>
<pm>
  <suspend-to-mem enabled='no'/>
  <suspend-to-disk enabled='no'/>
</pm>
<devices>
  <emulator>/usr/bin/kvm-spice</emulator>
  <disk type='file' device='disk'>
    <driver name='qemu' type='qcow2'/>
    <source file='/var/lib/libvirt/images/vbng.qcow2'/>
    <backingStore/>
    <target dev='hda' bus='ide'/>
    <alias name='ide0-0-0'/>
    <address type='drive' controller='0' bus='0' target='0' unit='0'/>
  </disk>
  <disk type='file' device='cdrom'>
    <driver name='qemu' type='raw'/>
    <backingStore/>
    <target dev='hdb' bus='ide'/>
    <readonly/>
    <alias name='ide0-0-1'/>
    <address type='drive' controller='0' bus='0' target='0' unit='1'/>
  </disk>
  <controller type='usb' index='0' model='ich9-ehci1'>
    <alias name='usb'/>
    <address type='pci' domain='0x0000' bus='0x00' slot='0x06' function='0x7'/>
  </controller>
  <controller type='usb' index='0' model='ich9-uhci1'>
    <alias name='usb'/>
    <master startport='0'/>
    <address type='pci' domain='0x0000' bus='0x00' slot='0x06' function='0x0'
multifunction='on'/>
  </controller>
  <controller type='usb' index='0' model='ich9-uhci2'>
    <alias name='usb'/>
    <master startport='2'/>
    <address type='pci' domain='0x0000' bus='0x00' slot='0x06' function='0x1'/>
  </controller>
  <controller type='usb' index='0' model='ich9-uhci3'>
    <alias name='usb'/>
    <master startport='4'/>
    <address type='pci' domain='0x0000' bus='0x00' slot='0x06' function='0x2'/>
  </controller>
  <controller type='pci' index='0' model='pci-root'>
    <alias name='pci.0'/>
  </controller>
  <controller type='ide' index='0'>
    <alias name='ide'/>
    <address type='pci' domain='0x0000' bus='0x00' slot='0x01' function='0x1'/>
  </controller>
  <controller type='virtio-serial' index='0'>
    <alias name='virtio-serial0'/>
    <address type='pci' domain='0x0000' bus='0x00' slot='0x05' function='0x0'/>
  </controller>
  <interface type='network'>
    <mac address='52:54:00:80:e7:05'/>
    <source network='default' bridge='virbr0'/>
    <target dev='vnet0'/>
    <model type='rtl8139'/>
    <alias name='net0'/>
    <address type='pci' domain='0x0000' bus='0x00' slot='0x03' function='0x0'/>

```

```

</interface>
<serial type='pty'>
  <source path='/dev/pts/5'>
  <target port='0'>
  <alias name='serial0'>
</serial>
<console type='pty' tty='/dev/pts/5'>
  <source path='/dev/pts/5'>
  <target type='serial' port='0'>
  <alias name='serial0'>
</console>
<channel type='spicevmc'>
  <target type='virtio' name='com.redhat.spice.0' state='disconnected'>
  <alias name='channel0'>
  <address type='virtio-serial' controller='0' bus='0' port='1'>
</channel>
<redirdev bus='usb' type='spicevmc'>
  <alias name='redir0'>
</redirdev>
<redirdev bus='usb' type='spicevmc'>
  <alias name='redir1'>
</redirdev>
<memballoon model='virtio'>
  <alias name='balloon0'>
  <address type='pci' domain='0x0000' bus='0x00' slot='0x07' function='0x0'>
</memballoon>
</devices>
<seclabel type='dynamic' model='apparmor' relabel='yes'>
  <label>libvirt-7c0c20b3-b9b6-462c-a1e6-01d3efac0abe</label>
  <imagelabel>libvirt-7c0c20b3-b9b6-462c-a1e6-01d3efac0abe</imagelabel>
</seclabel>
<qemu:commandline>
  <qemu:arg value='-numa'>
  <qemu:arg value='node,memdev=mem'>
  <qemu:arg value='-mem-prealloc'>
  <qemu:arg value='-object'>
  <qemu:arg
value='memory-backend-file,id=mem,size=8G,mem-path=/dev/hugepages,share=on,share=on'>
  <qemu:arg value='-netdev'>
  <qemu:arg value='vhost-user,id=hostnet1,chardev=vhost-user-vm1-int,vhostforce'>
  <qemu:arg value='-device'>
  <qemu:arg
value='virtio-net-pci,netdev=hostnet1,id=net1,mac=52:54:00:00:01:01,mrg_rxbuf=on'>
  <qemu:arg value='-chardev'>
  <qemu:arg value='socket,id=vhost-user-vm1-int,server,path=/tmp/vhost-user-vm1-int1'>
  <qemu:arg value='-netdev'>
  <qemu:arg value='vhost-user,id=hostnet2,chardev=vhost-user-vm1-int2,vhostforce'>
  <qemu:arg value='-device'>
  <qemu:arg
value='virtio-net-pci,netdev=hostnet2,id=net2,mac=52:54:00:00:01:02,mrg_rxbuf=on'>
  <qemu:arg value='-chardev'>
  <qemu:arg value='socket,id=vhost-user-vm1-int2,server,path=/tmp/vhost-user-vm1-int2'>
</qemu:commandline>
</domain>

```

Configuring PPPoE over an L2TPv3 Tunnel on the Cisco CSR 1000v

Enter the following commands on the Cisco CSR 1000v, to configure PPPoE over an L2TPv3 tunnel.

```

configure terminal
interface Tunnel0
  mac-address 0000.5e00.5213
  ip address 10.10.151.1 255.255.255.0
  tunnel mode ethernet l2tpv3 manual
  l2tp id 222 111
  l2tp cookie local 8 54321
  l2tp cookie remote 8 12345
  tunnel destination 2001:DB8:1111:2222::1

```

```
tunnel source 2001:DB8:2:2::1
tunnel VLAN 10
service-policy type control POLICY1
pppoe enable group 1
```

`tunnel mode ethernet l2tpv3` specifies L2TPv3 as the tunneling method. The `l2tp id` command specifies the local and remote session IDs and the `l2tp cookie local` command configures a cookie field with a size in bytes (for example, 8 bytes) and a low value (for example, 54321).

`l2tp cookie remote` configures a cookie field with a size in bytes (for example, 8 bytes) and a low value (for example, 12345). The cookie field is part of the Layer 2 Tunnel Protocol Version 3 (L2TPv3) headers in outgoing packets that are sent from the local PE peer router.

The `tunnel destination` is the destination IPv6 address on the OLT/DSLAM that connects to the CPE. This is the end tunnel destination from the point of view of the vBNG (on the Cisco CSR 1000v).

`tunnel source` —source IPv6 address of the vBNG (on the Cisco CSR 1000v, on the x86 server).

This is another example showing different cookie options:

```
interface Tunnell
mac-address aaaa.bbbb.1101
no ip address
ip verify unicast source reachable-via rx
pppoe enable group global
tunnel source GigabitEthernet1
tunnel mode ethernet l2tpv3 manual
tunnel destination 1111:1101::ABCD
tunnel path-mtu-discovery
tunnel vlan 401
l2tp static remote session 1
l2tp static remote cookie size 8 value 0x4 0x4
l2tp static local session 1
l2tp static local cookie size 8 value 0x4 0x4
!
```

Refer to the Cisco CSR 1000v router configurations in [Configuring PPPoE over an L2TPv3 Tunnel on the Cisco CSR 1000v](#), on page 325.

Verifying PPPoE Sessions

To display information about PPPoE sessions running on the L2TPv3 tunnels, enter the **show pppoe summary** command.

This displays a summary of the currently active PPP over Ethernet (PPPoE) sessions per interface. For further information, see the [Cisco IOS Broadband Access Aggregation and DSL Command Reference](#). The following example shows summary information about the PPPoE sessions running over tunnel Tunnell.

```
Device# show pppoe summary
Load for five secs: 0%/0%; one minute: 0%; five minutes: 0%
No time source, *10:26:27.815 UTC Thu Oct 19 2017
```

```
PTA : Locally terminated sessions
FWDED: Forwarded sessions
TRANS: All other sessions (in transient state)
```

	TOTAL	PTA	FWDED	TRANS
TOTAL	1	1	0	0
Tunnell	1	1	0	0

```
Device#
```

Enter the `show pppoe session` command to display the currently active PPP over Ethernet (PPPoE) sessions.

```
Device# show pppoe session
```

```
Load for five secs: 15%/0%; one minute: 14%; five minutes: 13%
No time source, *16:19:38.030 UTC Thu Oct 26 2017
```

```
8000 sessions in LOCALLY_TERMINATED (PTA) State
8000 sessions total
```

Uniq ID	PPPoE SID	RemMAC LocMAC	Port	VT	VA VA-st	State Type
596	596	0011.9400.0080 aaaa.bbbb.1101	Tu1	1	Vi2.585 UP	PTA
598	598	0011.9400.0081 aaaa.bbbb.1101	Tu1	1	Vi2.586 UP	PTA
601	601	0011.9400.0082 aaaa.bbbb.1101	Tu1	1	Vi2.592 UP	PTA
605	605	0011.9400.0083 aaaa.bbbb.1101	Tu1	1	Vi2.593 UP	PTA
608	608	0011.9400.0084 aaaa.bbbb.1101	Tu1	1	Vi2.600 UP	PTA
612	612	0011.9400.0085 aaaa.bbbb.1101	Tu1	1	Vi2.602 UP	PTA
616	616	0011.9400.0086 aaaa.bbbb.1101	Tu1	1	Vi2.606 UP	PTA
619	619	0011.9400.0087 aaaa.bbbb.1101	Tu1	1	Vi2.610 UP	PTA
1	1	0011.9400.0008	Tu1	1	Vi2.3	PTA

Device#

Perform the show platform hardware qfp active feature subscriber segment command to view the segment ids. Example:

```
Device# show platform hardware qfp active feature subscriber segment
Load for five secs: 12%/0%; one minute: 13%; five minutes: 13%
No time source, *16:22:02.582 UTC Thu Oct 26 2017
```

Current number segments: 16000

Segment	SegType	QFP Hd1	PeerSeg	Status
0x0000003600003006	PPPOE	49	0x000000360000600b	BOUND
0x000000360000600b	LTERM	49	0x0000003600003006	BOUND
0x0000003800004008	PPPOE	50	0x000000380000700c	BOUND
...				

Device#

To display the PPPoE encapsulation, enter the show platform software subscriber fp active segment id command as shown in the following example. This example shows the PPPoE encapsulation for one of the segments identified in the previous example, with Segment ID= 0x0000003600003006.

```
Device# show platform software subscriber fp active segment id 0x0000003600003006
```

```
Load for five secs: 14%/0%; one minute: 13%; five minutes: 13%
No time source, *16:24:11.425 UTC Thu Oct 26 2017
```

Segment	SegType	EVSI	Changes	AOM Id	AOM State
0x0000003600003006	PPPoE	54	0x00000000	651	created

```
PPPoE Session id 0x3
MAC enctype 0x1a
Switch Mode 0x2
Max MTU 0x5b4
VLAN cos 0x8
Phy Intf (on CPP) 0x10
Conditional Debug OFF
MAC Address Local: aaaabbbb1109
MAC Address Remote: 002194000008
PPPoE encap string [76 bytes]: 6000000000073ff11112222000000000000000000000000cdef1111110900000000000000000000abcd000000090000000400000004002194000008aaaabbbb1109810001998864110000030000
```

```

Flow Information:
Flows activated/attached: 2/2
Input Classes: 2
  Id      Priority  Flow EVSI  Class-Group Id  Filter Type:
  -----
                Filter Name
                -----
                2          0    4210704    368259939.1    Named ACL:
                4          0    4210705    368259939.2    acct_in
                Named ACL:
                acct_inv6
Output Classes: 2
  Id      Priority  Flow EVSI  Class-Group Id  Filter Type:
  -----
                Filter Name
                -----
                3          0    4210704    146674515.1    Named ACL:
                acct_out
                5          0    4210705    146674515.2    Named ACL:
                acct_outv6

```

Device#

To display MAC string information for a segment, use the `show platform hardware qfp` command as shown in the following example:

```
Device# show platform hardware qfp active feature subscriber segment id 0x0000003600003006
```

```

Load for five secs: 12%/0%; one minute: 13%; five minutes: 13%
No time source, *16:28:59.639 UTC Thu Oct 26 2017
Segment ID: 0x3600003006

```

```

EVSI: 54
Peer Segment ID: 0x360000600b
QFP vsi if handle: 49
QFP interface name: EVSI54
Segment type: PPPOE
Is conditional debug: 0
Is SIP: 1
Segment status: BOUND
Macstring length: 76
00000000 6000 0000 0000 73ff 1111 2222 0000 0000
00000010 0000 0000 0000 cdef 1111 1109 0000 0000
00000020 0000 0000 0000 abcd 0000 0009 0000 0004
00000030 0000 0004 0021 9400 0008 aaaa bbbb 1109
00000040 8100 0199 8864 1100 0003 0000

```

```

Encap info exmem handle: 0x0
session id: 3
vcd: 409
mtu: 1460
physical if handle: 16
hash value: 0x0000bd8c
Input Classes: 2
  Class Id  Flow EVSI      CG Id          QFP Hd1
  -----
                2    4210704    368259939.1    54
                4    4210705    368259939.2    55
Output Classes: 2
  Class Id  Flow EVSI      CG Id          QFP Hd1
  -----
                3    4210704    146674515.1    54
                5    4210705    146674515.2    55

```

Device#

Verifying PPPoE over L2TPv3 Tunnels

To show the adjacency created after a PPPoE session is enabled for an L2TPv3 tunnel (Tunnell), enter the `show adjacency encapsulation` and `show adjacency detail` commands on the Cisco CSR 1000v. The PPPoE session goes from the vBNG on the Cisco CSR 1000v VM to the Agg/Edge router (for example, a Cisco ASR 9000). The following examples

```
vBNG# show adjacency encapsulation

RAW          Tunnell1                point2point(3)
Encap length 70
60000000000073FF1111222200000000
000000000000CDEF1111110100000000
000000000000ABCD0000000100000004
00000004000000000000AAAABBBB1101
810001918864
Provider: TUNNEL
Protocol header count in macstring: 1
HDR 0: ipv6
  dst: static, 1111:1101::ABCD
  src: static, 1111:2222::CDEF
  prot: static, 115
  tc: static, 0
  flow: static, 0
  hops: static, 255
  per packet fields: payload_length
vBNG# show adjacency detail
IPV6      GigabitEthernet1      FE80::AA0C:DFE:FE53:2061(3)
          0 packets, 0 bytes
          epoch 0
          sourced in sev-epoch 45988
          Encap length 14
          A80C0D53206152540000010186DD
          L2 destination address byte offset 0
          L2 destination address byte length 6
          Link-type after encap: ipv6
          IPv6 ND
```

Show the running configuration for the L2TPv3 tunnel interface.

```
vBNG# show running-configuration interface Tunnell1

Load for five secs: 1%/0%; one minute: 0%; five minutes: 0%
No time source, *10:58:51.169 UTC Wed Oct 18 2017

Building configuration...

Current configuration : 440 bytes
!
interface Tunnell1
  mac-address aaaa.bbbb.1101
  no ip address
  ip verify unicast source reachable-via rx
  pppoe enable group global
  tunnel source GigabitEthernet1
  tunnel mode ethernet l2tpv3 manual
  tunnel destination 1111:1101::ABCD
  tunnel path-mtu-discovery
  tunnel vlan 401
  l2tp static remote session 1
  l2tp static remote cookie size 8 value 0x4 0x4
  l2tp static local session 1
  l2tp static local cookie size 8 value 0x4 0x4
```

To show the L2TPv3 tunnel interface, enter the `show interface` command as shown in the following example.

```
vBNG# show interface Tunnell1

Load for five secs: 0%/0%; one minute: 0%; five minutes: 0%
No time source, *10:59:18.610 UTC Wed Oct 18 2017
```

```

Tunnell is up, line protocol is up
Hardware is Tunnel
MTU 1460 bytes, BW 100 Kbit/sec, DLY 50000 usec,
    reliability 255/255, txload 1/255, rxload 1/255
Encapsulation TUNNEL, loopback not set
Keepalive not set
Tunnel linestate evaluation up
Tunnel source 1111:2222::CDEF (GigabitEthernet1), destination 1111:1101::ABCD
Tunnel Subblocks:
    src-track:
        Tunnell source tracking subblock associated with GigabitEthernet1
        Set of tunnels with source GigabitEthernet1, 41 members (includes iterators), on
interface <OK>
Tunnel protocol/transport L2TP/IPV6
    L2TPv3
        remote session-id:1
        local session-id:1
        local cookie size:8, low value:0x4, high value:0x4
        remote cookie size:8, low value:0x4, high value:0x4
Tunnel TTL 255
Path MTU Discovery, ager 10 mins, min MTU 1280
Tunnel transport MTU 1460 bytes
Tunnel transmit bandwidth 8000 (kbps)
Tunnel receive bandwidth 8000 (kbps)
Last input never, output 1d03h, output hang never
Last clearing of "show interface" counters 3d03h
Input queue: 0/375/0/0 (size/max/drops/flushes); Total output drops: 0
Queueing strategy: fifo
Output queue: 0/0 (size/max)
5 minute input rate 0 bits/sec, 0 packets/sec
5 minute output rate 0 bits/sec, 0 packets/sec
 9583487 packets input, 9983601325 bytes, 0 no buffer
Received 0 broadcasts (0 IP multicasts)
 0 runts, 0 giants, 0 throttles
 0 input errors, 0 CRC, 0 frame, 0 overrun, 0 ignored, 0 abort
13458 packets output, 1739662 bytes, 0 underruns
 0 output errors, 0 collisions, 0 interface resets
 0 unknown protocol drops
 0 output buffer failures, 0 output buffers swapped out

```

vBNG#

The following command shows the IPsec Cisco Quantum Flow Processor (QFP) information about tunnell.

```
vBNG# show platform hardware qfp active feature tunnel interface tunnell
```

```
Load for five secs: 0%/0%; one minute: 0%; five minutes: 0%
No time source, *10:56:51.924 UTC Wed Oct 18 2017
```

General interface info:

```

Interface name: Tunnell
Platform interface handle: 11
QFP interface handle: 8
QFP complex: 0
Rx uIDB: 65530 Tx uIDB: 65528
Hash index : 0x0003f6
Hash element ppe addr : 0xe89bf440
ESP Hash element ppe addr : 00000000
AH Hash element ppe addr : 00000000
UDP Hash element ppe addr : 00000000
Output sb ppe addr : 0xe816fc20
Decap chk sb ppe addr : 00000000
DMVPN sb ppe addr input: 00000000 output: 00000000
SGRE input sb ppe addr : 00000000
L2TPoIPV6 input sb ppe addr : 0xe75c6000

```

Config:

```

mode: L2TPV3oIPV6
src IP: 1111:2222:0000:0000:0000:0000:0000:cdef dest IP:
1111:1101:0000:0000:0000:0000:0000:abcd
ipv4_intf_vrf: 0 tun_vrf: 0 tun_vrf_egress: 0
key: 0 flags: 0x0081 app_id: TUN_APP_CLI app_data: 0
ttl: 255 tos: 0
tunnel_protection: FALSE
virtual MAC: aaaa.bbbb.1101
lport: 0 rport: 0

```

```

tunnel_enable_entropy: FALSE
remote_session_id: 1 vlan id for l2tpoipv6: 401
remote_cookie_size: 8 local_cookie_size: 8 local_cookie_secondary_size: 255
remote_cookie_low: 4 remote_cookie_high: 4
local_cookie_low: 4 local_cookie_high: 4
local_cookie_secondary_low: 0 local_cookie_secondary_high: 0

```

The following show running-configuration command, shows the Cisco CSR 1000v VM configuration on the x86 server.

```

vBNG# show running-configuration

Building configuration...

Current configuration : 4401 bytes
!
! Last configuration change at 13:38:48 IST Tue Oct 17 2017
!
version 16.6
service timestamps debug datetime msec
service timestamps log datetime msec
platform qfp utilization monitor load 80
no platform punt-keepalive disable-kernel-core
!
hostname vBNG
!
boot-start-marker
boot system harddisk:asr1000rpx86-universalk9.2017-06-16_14.49_vijasin3.SSA.bin
boot-end-marker
!
!
vrf definition Mgmt-intf
!
 address-family ipv4
 exit-address-family
!
 address-family ipv6
 exit-address-family
!
logging buffered 10000000
no logging console
!
aaa new-model
!
!
aaa group server radius GROUP1
 server name RAD1
!
aaa group server radius acct
 server name RAD1
!
aaa authentication login CONSOLE none
aaa authentication ppp default local
aaa authorization network default local
aaa authorization subscriber-service default local
aaa accounting update periodic 1
aaa accounting network default start-stop group GROUP1
aaa accounting network List1 start-stop group GROUP1
!
aaa session-id common
clock timezone IST 5 30
!
subscriber templating
subscriber accounting accuracy 10000
!
ipv6 unicast-routing
!
!
multilink bundle-name authenticated
vpdn enable
vpdn authen-before-forward

```

```

!
vpdn-group test1
  accept-dialin
  protocol l2tp
  virtual-template 1
  terminate-from hostname CSR_TENGIG
  l2tp tunnel password 0 cisco
!
!
crypto pki trustpoint TP-self-signed-336246438
  enrollment selfsigned
  subject-name cn=IOS-Self-Signed-Certificate-336246438
  revocation-check none
  rsakeypair TP-self-signed-336246438
!
!
crypto pki certificate chain TP-self-signed-336246438
!
!
license udi pid ASR1006 sn NWG123704SS
license accept end user agreement
license boot level adventerprise
spanning-tree extend system-id
diagnostic bootup level minimal
!
!
username user1@cisco.com password 0 cisco
username lac@cisco.com password 0 cisco
username user1lac@cisco.com password 0 cisco
username user2lac@cisco.com password 0 cisco
username lacupsrl@cisco.com password 0 cisco
username lacdownsrl@cisco.com password 0 cisco
!
redundancy
  mode sso
!
!
interface GigabitEthernet0/0/0
  ip address 9.45.102.50 255.255.0.0
  ip nat outside
  negotiation auto
!
<commands removed for brevity>

interface TenGigabitEthernet0/2/0
  ip address 40.1.1.2 255.255.255.0
  ip nat inside
!
interface TenGigabitEthernet0/3/0
  ip address 50.1.1.1 255.255.255.0
!
interface GigabitEthernet0
  vrf forwarding Mgmt-intf
  no ip address
  negotiation auto
!
interface Virtual-Template1
  ip unnumbered TenGigabitEthernet0/2/0
  peer default ip address pool test1
  peer default ipv6 pool test1_v6
  ipv6 unnumbered TenGigabitEthernet0/2/0
  ppp mtu adaptive
  ppp authentication pap chap
!
interface Virtual-Template2
  ip unnumbered GigabitEthernet0/0/3
  ppp authentication pap
!
ip local pool test1 2.1.1.1 2.1.1.254
ip nat inside source list 1 interface GigabitEthernet0/0/0 overload
ip forward-protocol nd
ip http server
ip http authentication local

```

```

ip http secure-server
ip tftp source-interface GigabitEthernet0/0/0
ip tftp blocksize 8192
ip route 0.0.0.0 0.0.0.0 9.45.0.1
ip route 1.1.0.0 255.255.0.0 40.1.1.1
ip route 10.1.1.0 255.255.255.0 40.1.1.1
ip route 20.1.1.0 255.255.255.0 40.1.1.1
ip route 30.1.1.0 255.255.255.0 40.1.1.1
ip route 100.1.0.0 255.255.0.0 60.1.1.1
ip route 200.1.0.0 255.255.0.0 60.1.1.1
ip route 202.153.144.25 255.255.255.255 9.45.0.1
!
ip ssh server algorithm encryption aes128-ctr aes192-ctr aes256-ctr
ip ssh client algorithm encryption aes128-ctr aes192-ctr aes256-ctr
!
access-list 1 permit 30.1.1.0 0.0.0.255
access-list 1 permit any
ipv6 local pool test1_v6 5555::/48 64
!
radius server RAD1
 address ipv4 10.64.67.97 auth-port 1645 acct-port 1646
 key cisco123
!
!
control-plane
!
line con 0
 stopbits 1
line vty 0 4
!
end
    
```

Troubleshooting PPPoE over L2TPv3 Tunnels

Enter the following command to obtain information about a tunnel:

```
debug tunnel l2tp ipv6
```

In the following example, the normal case is shown, where the tunnel interface is shown as being up and running.

```

vBNG# debug tunnel l2tp ipv6
*Oct 19 10:32:38.475: %LINEPROTO-5-UPDOWN: Line protocol on Interface Tunnel30, changed
state to up
*Oct 19 10:32:38.478: Tunnel30: Adding 12 bytes for l2tp header
*Oct 19 10:32:38.478: Tunnel30: L2TPv3 header session id: 0x1E, cookie low: 0x4, cookie
high: 0x4
*Oct 19 10:32:38.478: Tunnel30: Adding 18 bytes for ethernet header
*Oct 19 10:32:38.478: Tunnel30: Ethernet header, dst mac:0000.0000.0000, src
mac:aaaa.bbbb.1130, dot1q, vlan:430, ethertype:34916
*Oct 19 10:32:38.485: %LINK-3-UPDOWN: Interface Tunnel30, changed state to up
    
```

Additional References for Configuring PPPoE over L2TPv3 Tunnels

Related Documents

Related Topic	Document Title
PPP over Ethernet	Broadband Access Aggregation and DSL Configuration Guide

Related Topic	Document Title
Virtual Private Dialup Networks (VPDNs)	Virtual Private Dialup Network (VPDN)
Configuring VPDNs	VPDN Configuration Guide
Configuring L2TPv3 over IPv6Tunnels	L2VPN and Ethernet Services Configuration Guide
L2TP VPDN tunnels	VPDN Tunnel Management

RFCs

RFCs	Title
RFC 8159	Keyed IPv6 Tunnel

Technical Assistance

Description	Link
The Cisco Support and Documentation website provides online resources to download documentation, software, and tools. Use these resources to install and configure the software and to troubleshoot and resolve technical issues with Cisco products and technologies. Access to most tools on the Cisco Support and Documentation website requires a Cisco.com user ID and password.	http://www.cisco.com/cisco/web/support/index.html

Feature Information for Configuring PPPoE over L2TPv3 Tunnels

The following table provides release information about the feature or features described in this module. This table lists only the software release that introduced support for a given feature in a given software release train. Unless noted otherwise, subsequent releases of that software release train also support that feature.

Use Cisco Feature Navigator to find information about platform support and Cisco software image support. To access Cisco Feature Navigator, go to www.cisco.com/go/cfn. An account on Cisco.com is not required.

Table 36: Feature Information for Configuring PPPoE over L2TPv3 Tunnels

Feature Name	Software Releases	Feature Information
Configuring PPPoE over L2TPv3 Tunnels	Cisco IOS XE Fuji 16.7.1	Use this feature to transport PPPoE packets between network sites in Layer 2 Tunneling Protocol Version 3 (L2TPv3) tunnels using IPv6.



ADSL Support in IPv6

Asymmetric Digital Subscriber Line (ADSL) support in IPv6 provides the extensions that make large-scale access possible for IPv6 environments, including IPv6 RADIUS attributes, stateless address configuration on PPP links, per-user static routes, and ACLs.

- [Finding Feature Information, page 337](#)
- [Restrictions for ADSL Support in IPv6, page 337](#)
- [ADSL Support in IPv6, page 338](#)
- [How to Configure ADSL Support in IPv6, page 339](#)
- [Configuration Examples for ADSL Support in IPv6, page 344](#)
- [Additional References, page 344](#)
- [Feature Information for ADSL Support in IPv6, page 345](#)

Finding Feature Information

Your software release may not support all the features documented in this module. For the latest caveats and feature information, see [Bug Search Tool](#) and the release notes for your platform and software release. To find information about the features documented in this module, and to see a list of the releases in which each feature is supported, see the feature information table.

Use Cisco Feature Navigator to find information about platform support and Cisco software image support. To access Cisco Feature Navigator, go to www.cisco.com/go/cfn. An account on Cisco.com is not required.

Restrictions for ADSL Support in IPv6

ADSL and dial deployment are available for interfaces with PPP encapsulation enabled, including PPP over ATM (PPPoA), PPP over Ethernet (PPPoE), PPP over async, and PPP over ISDN.

ADSL Support in IPv6

Address Assignment for IPv6

A Cisco router configured with IPv6 will advertise its IPv6 prefixes on one or more interfaces, allowing IPv6 clients to automatically configure their addresses. In IPv6, address assignment is performed at the network layer, in contrast to IPv4 where a number of functions are handled in the PPP layer. The only function handled in IPv6 control protocol is the negotiation of a unique interface identifier. Everything else, including Domain Name Server (DNS) server discovery, is done within the IPv6 protocol itself.

Contrary to IPv4 address assignment, an IPv6 user will be assigned a prefix, not a single address. Typically, the ISP assigns a 64- or 48-bit prefix.

In IPv6, ISPs assign long-lived prefixes to users, which has some impact on the routing system. In typical IPv4 environments, each network access server (NAS) has a pool of 24-bit addresses and users get addresses from this pool when dialing in. If a user dials another point of presence (POP) or is connected to another NAS at the same POP, a different IPv4 address is assigned.

Addresses for IPv6 are assigned using two methods:

Stateless Address Autoconfiguration

Assigning addresses using the stateless address autoconfiguration method can be used only to assign 64-bit prefixes. Each user is assigned a 64-bit prefix, which is advertised to the user in a router advertisement (RA). All addresses are automatically configured based on the assigned prefix.

A typical scenario is to assign a separate 64-bit prefix per user; however, users can also be assigned a prefix from a shared pool of addresses. Using the shared pool limits addresses to only one address per user.

This method works best for the cases where the customer provider edge (CPE) router is a single PC or is limited to only one subnet. If the user has multiple subnets, Layer 2 (L2) bridging, multilink subnets or proxy RA can be used. The prefix advertised in the RA can come from an authorization, authentication, and accounting (AAA) server, which also provides the prefix attribute, can be manually configured, or can be allocated from a prefix pool.

The Framed-Interface-Id AAA attribute influences the choice of interface identifier for peers and, in combination with the prefix, the complete IPv6 address can be determined.

How to Configure ADSL Support in IPv6

Configuring the NAS

SUMMARY STEPS

1. **enable**
2. **configure terminal**
3. **hostname** *name*
4. **aaa new-model**
5. **aaa authentication ppp** {**default** | *list-name*} *method1* [*method2*...]
6. **aaa authorization configuration default** {**radius** | **tacacs+**}
7. **show ipv6 route** [*ipv6-address* | *ipv6-prefix* / *prefix-length* | *protocol* | *interface-type interface-number*]
8. **virtual-profile virtual-template** *number*
9. **interface serial** *controller-number* : *timeslot*
10. **encapsulation** *encapsulation-type*
11. **exit**
12. **dialer-group** *group-number*
13. **ppp authentication** *protocol1* [*protocol2*...] [**if-needed**] [*list-name* | **default**] [**callin**] [**one-time**] [**optional**]
14. **interface virtual-template** *number*
15. **ipv6 enable**
16. **dialer-list** *dialer-group* **protocol** *protocol-name* {**permit** | **deny** | **list** *access-list-number* | *access-group*}
17. **radius-server host** {*hostname* | *ip-address*} [**test username** *user-name*] [**auth-port** *port-number*] [**ignore-auth-port**] [**acct-port** *port-number*] [**ignore-acct-port**] [**timeout** *seconds*] [**retransmit** *retries*] [**key string**] [**alias** {*hostname* | *ip-address*}] [**idle-time** *seconds*]

DETAILED STEPS

	Command or Action	Purpose
Step 1	enable Example: Router> enable	Enables privileged EXEC mode. <ul style="list-style-type: none"> • Enter your password if prompted.
Step 2	configure terminal Example: Router# configure terminal	Enters global configuration mode.

	Command or Action	Purpose
Step 3	hostname <i>name</i> Example: Router(config)# hostname cust1-53a	Specifies the hostname for the network server.
Step 4	aaa new-model Example: Router(config)# aaa new-model	Enables the AAA server.
Step 5	aaa authentication ppp {default <i>list-name</i> } <i>method1</i> [<i>method2...</i>] Example: Router(config)# aaa authentication ppp default if-needed group radius	Specifies one or more AAA authentication methods for use on serial interfaces that are running PPP.
Step 6	aaa authorization configuration default {radius tacacs+} Example: Router(config)# aaa authorization configuration default radius	Downloads configuration information from the AAA server.
Step 7	show ipv6 route [<i>ipv6-address</i> <i>ipv6-prefix / prefix-length</i> <i>protocol</i> <i>interface-type interface-number</i>] Example: Router(config)# show ipv6 route	Shows the routes installed by the previous commands.
Step 8	virtual-profile virtual-template <i>number</i> Example: Router(config)# virtual-profile virtual-template 1	Enables virtual profiles by virtual interface template.
Step 9	interface serial <i>controller-number</i> : <i>timeslot</i> Example: Router(config)# interface serial 0:15	Specifies a serial interface created on a channelized E1 or channelized T1 controller (for ISDN PRI, channel-associated signaling, or robbed-bit signaling). This command also puts the router into interface configuration mode.
Step 10	encapsulation <i>encapsulation-type</i> Example: Router(config-if)# encapsulation ppp	Sets the encapsulation method used by the interface.

	Command or Action	Purpose
Step 11	exit Example: <pre>Router(config-if)# exit</pre>	Returns to global configuration mode.
Step 12	dialer-group <i>group-number</i> Example: <pre>Router(config)# dialer-group 1</pre>	Controls access by configuring an interface to belong to a specific dialing group.
Step 13	ppp authentication <i>protocol1</i> [<i>protocol2...</i>] [if-needed] [<i>list-name</i> default] [callin] [one-time] [optional] Example: <pre>Router(config)# ppp authentication chap</pre>	Enables Challenge Handshake Authentication Protocol (CHAP) or Password Authentication Protocol (PAP) or both and specifies the order in which CHAP and PAP authentication are selected on the interface.
Step 14	interface virtual-template <i>number</i> Example: <pre>Router(config)# interface virtual-template 1</pre>	Creates a virtual template interface that can be configured and applied dynamically in creating virtual access interfaces.
Step 15	ipv6 enable Example: <pre>Router(config)# ipv6 enable</pre>	Enables IPv6 processing on an interface that has not been configured with an explicit IPv6 address.
Step 16	dialer-list <i>dialer-group</i> protocol <i>protocol-name</i> {permit deny list <i>access-list-number</i> <i>access-group</i>} Example: <pre>Router(config)# dialer-list 1 protocol ipv6 permit</pre>	Defines a dial-on-demand routing (DDR) dialer list for dialing by protocol or by a combination of a protocol and a previously defined access list.
Step 17	radius-server host {<i>hostname</i> <i>ip-address</i>} [test <i>username</i> <i>user-name</i>] [auth-port <i>port-number</i>] [ignore-auth-port] [acct-port <i>port-number</i>] [ignore-acct-port] [timeout <i>seconds</i>] [retransmit <i>retries</i>] [key string] [alias {<i>hostname</i> <i>ip-address</i>}] [idle-time <i>seconds</i>] Example: <pre>Router(config)# radius-server host 172.17.250.8 auth-port 1812 acct-port 1813 key testing123</pre>	Specifies a RADIUS server host.

Configuring the Remote CE Router

SUMMARY STEPS

1. **enable**
2. **configure terminal**
3. **hostname** *name*
4. **interface bri** *number . subinterface-number* [**multipoint** | **point-to-point**]
5. **encapsulation** *encapsulation-type*
6. **ipv6 address autoconfig** [**default**
7. **isdn switch-type** *switch-type*
8. **ppp authentication** {*protocol1* [*protocol2...*]} [**if-needed**] [*list-name* | **default**] [**callin**] [**one-time**]
9. **ppp multilink** [**bap** | **required**]
10. **exit**
11. **dialer-list** *dialer-group* **protocol** *protocol-name* [**permit** | **deny** | **list** *access-list-number* | *access-group*]
12. **ipv6 route** *ipv6-prefix* / *prefix-length* {*ipv6-address* | *interface-type interface-number ipv6-address*}} [*administrative-distance*] [*administrative-multicast-distance* | **unicast** | **multicast**] [**tag** *tag*]

DETAILED STEPS

	Command or Action	Purpose
Step 1	enable Example: Router> enable	Enables privileged EXEC mode. • Enter your password if prompted.
Step 2	configure terminal Example: Router# configure terminal	Enters global configuration mode.
Step 3	hostname <i>name</i> Example: Router(config)# hostname cust1-36a	Specifies the hostname for the network server.
Step 4	interface bri <i>number . subinterface-number</i> [multipoint point-to-point] Example: Router(config)# interface bri 1.0	Configures a BRI interface.

	Command or Action	Purpose
Step 5	<p>encapsulation <i>encapsulation-type</i></p> <p>Example:</p> <pre>Router(config-if)# encapsulation ppp</pre>	Sets the encapsulation method used by the interface.
Step 6	<p>ipv6 address autoconfig [default</p> <p>Example:</p> <pre>Router(config-if)# ipv6 address autoconfig</pre>	Indicates that the IPv6 address will be generated automatically.
Step 7	<p>isdn switch-type <i>switch-type</i></p> <p>Example:</p> <pre>Router(config-if)# isdn switch-type basic-net3</pre>	Specifies the central office switch type on the ISDN interface.
Step 8	<p>ppp authentication {<i>protocol1</i> [<i>protocol2...</i>]} [if-needed] [<i>list-name</i> default] [callin] [one-time]</p> <p>Example:</p> <pre>Router(config-if)# ppp authentication chap</pre>	Enables Challenge Handshake Authentication Protocol (CHAP) or Password Authentication Protocol (PAP) or both and specifies the order in which CHAP and PAP authentication are selected on the interface.
Step 9	<p>ppp multilink [bap required]</p> <p>Example:</p> <pre>Router(config-if)# ppp multilink</pre>	Enables Multilink PPP (MLP) on an interface and, optionally, enables Bandwidth Allocation Control Protocol (BACP) and Bandwidth Allocation Protocol (BAP) for dynamic bandwidth allocation.
Step 10	<p>exit</p> <p>Example:</p> <pre>Router(config-if)# exit</pre>	Exits interface configuration mode and returns to global configuration mode.
Step 11	<p>dialer-list <i>dialer-group</i> protocol <i>protocol-name</i> {permit deny list <i>access-list-number</i> <i>access-group</i>}</p> <p>Example:</p> <pre>Router(config)# dialer-list 1 protocol ipv6 permit</pre>	Defines a dial-on-demand routing (DDR) dialer list for dialing by protocol or by a combination of a protocol and a previously defined access list.
Step 12	<p>ipv6 route <i>ipv6-prefix</i> / <i>prefix-length</i> {<i>ipv6-address</i> <i>interface-type interface-number ipv6-address</i>} [<i>administrative-distance</i>] [<i>administrative-multicast-distance</i>] [unicast multicast] [tag <i>tag</i>]</p> <p>Example:</p> <pre>Router(config)# ipv6 route 2001:DB8::1/128 BRI1/0</pre>	<p>Establishes static IPv6 routes.</p> <ul style="list-style-type: none"> • Use one command for each route.

Configuration Examples for ADSL Support in IPv6

Example: NAS Configuration

This configuration for the ISP NAS shows the configuration that supports access from the remote CE router.

```
hostname cust1-53a
aaa new-model
aaa authentication ppp default if-needed group radius
aaa authorization network default group radius
virtual-profile virtual-template 1
interface Serial0:15
  encapsulation ppp
  dialer-group 1
  ppp authentication chap
!
interface Virtual-Template1
  ipv6 enable
!
dialer-list 1 protocol ipv6 permit
radius-server host 172.17.250.8 auth-port 1812 acct-port 1813 key testing123
```

Example: Remote CE Router Configuration

This configuration for the remote customer edge router shows PPP encapsulation and IPv6 routes defined.

```
hostname cust-36a
interface BRI1/0
  encapsulation ppp
  ipv6 enable
  isdn switch-type basic-net3
  ppp authentication chap optional
  ppp multilink
!
dialer-list 1 protocol ipv6 permit
ipv6 route 2001:DB8::1/128 BRI1/0
ipv6 route ::/0 2001:DB8::1
```

Additional References

Related Documents

Related Topic	Document Title
Cisco IOS commands	Cisco IOS Master Commands List, All Releases
Cisco IOS IPv6 features	Cisco IOS IPv6 Feature Mapping

Standards and RFCs

Standard/RFC	Title
RFCs for IPv6	<i>IPv6 RFCs</i>

MIBs

MIB	MIBs Link
	To locate and download MIBs for selected platforms, Cisco IOS releases, and feature sets, use Cisco MIB Locator found at the following URL: http://www.cisco.com/go/mibs

Technical Assistance

Description	Link
The Cisco Support and Documentation website provides online resources to download documentation, software, and tools. Use these resources to install and configure the software and to troubleshoot and resolve technical issues with Cisco products and technologies. Access to most tools on the Cisco Support and Documentation website requires a Cisco.com user ID and password.	http://www.cisco.com/cisco/web/support/index.html

Feature Information for ADSL Support in IPv6

The following table provides release information about the feature or features described in this module. This table lists only the software release that introduced support for a given feature in a given software release train. Unless noted otherwise, subsequent releases of that software release train also support that feature.

Use Cisco Feature Navigator to find information about platform support and Cisco software image support. To access Cisco Feature Navigator, go to www.cisco.com/go/cfn. An account on Cisco.com is not required.

Table 37: Feature Information for ADSL Support in IPv6

Feature Name	Releases	Feature Information
IPv6 ADSL and Dial Deployment Support	12.2(13)T	<p>ADSL and dial deployment provide the extensions that make large-scale access possible for IPv6 environments, including IPv6 RADIUS attributes, stateless address configuration on PPP links, per-user static routes, and ACLs.</p> <p>The following commands were introduced or modified: aaa authentication ppp, aaa authorization multicast default, aaa new-model, dialer-group, dialer-list, encapsulation, hostname, ipv6 address autoconfig, ipv6 route, isdn switch-type, ppp authentication, ppp multilink, radius-server host, show ipv6 route, virtual-profile virtual-template.</p>
IPv6 Access Services: PPPoA	12.2(13)T 12.3 12.3(2)T 12.4 12.4(2)T	ADSL and dial deployment is available for interfaces with PPP encapsulation enabled, including PPPoA.
IPv6 Access Services: PPPoE	12.2(13)T 12.3 12.3(2)T 12.4 12.4(2)T	ADSL and dial deployment is available for interfaces with PPP encapsulation enabled, including PPPoE.



CHAPTER 29

Broadband IPv6 Counter Support at LNS

- [Finding Feature Information, page 347](#)
- [Information About Broadband IPv6 Counter Support at LNS, page 347](#)
- [How to Verify Broadband IPv6 Counter Support at LNS, page 348](#)
- [Configuration Examples for Broadband IPv6 Counter Support at LNS, page 350](#)
- [Additional References, page 351](#)
- [Feature Information for Broadband IPv6 Counter Support at LNS, page 352](#)

Finding Feature Information

Your software release may not support all the features documented in this module. For the latest caveats and feature information, see [Bug Search Tool](#) and the release notes for your platform and software release. To find information about the features documented in this module, and to see a list of the releases in which each feature is supported, see the feature information table.

Use Cisco Feature Navigator to find information about platform support and Cisco software image support. To access Cisco Feature Navigator, go to www.cisco.com/go/cfn. An account on Cisco.com is not required.

Information About Broadband IPv6 Counter Support at LNS

Broadband IPv6 Counter Support at LNS

This feature provides support for broadband PPP IPv6 sessions at the layer 2 tunneling protocol (L2TP) network server (LNS). The sessions are forwarded by L2TP access concentrator (LAC) using layer 2 tunneling protocol L2TP over IPv6.

This feature is enabled automatically when the user configures LNS and enables IPv6.

How to Verify Broadband IPv6 Counter Support at LNS

Verifying Broadband IPv6 Counter Support at the LNS

This feature is enabled automatically when the user configures LNS and enables IPv6. To verify information about this feature, you can use any or all of the following optional commands as needed.

SUMMARY STEPS

1. **enable**
2. **show l2tp session** [all | packets [ipv6] | sequence | state | [brief | circuit | interworking] [hostname]] [ip-addr ip-addr[vcid vcid] | tunnel{id local-tunnel-id local-session-id} remote-name remote-tunnel-name local-tunnel-name} | username username | vcid vcid]
3. **show l2tp tunnel** [all | packets [ipv6] | state | summary | transport] [id local-tunnel-id | local-name local-tunnel-name remote-tunnel-name] remote-name remote-tunnel-name local-tunnel-name]
4. **show l2tun session** [l2tp | pptp] [all [filter] | brief [filter] [hostname] | circuit [filter] [hostname] | interworking [filter] [hostname] | packets ipv6] [filter] | sequence [filter] | state [filter]]
5. **show vpdn session** [l2f | l2tp | pptp] [all | packets [ipv6] | sequence | state [filter]]
6. **show vpdn tunnel** [l2f | l2tp | pptp] [all [filter] | packets ipv6] [filter] | state [filter] | summary [filter] | transport[filter]]

DETAILED STEPS

	Command or Action	Purpose
Step 1	enable Example: Router> enable	Enables privileged EXEC mode. <ul style="list-style-type: none"> • Enter your password if prompted.
Step 2	show l2tp session [all packets [ipv6] sequence state [brief circuit interworking] [hostname]] [ip-addr ip-addr[vcid vcid] tunnel{id local-tunnel-id local-session-id} remote-name remote-tunnel-name local-tunnel-name} username username vcid vcid] Example: Router# show l2tp session packets ipv6	Displays information about L2TP sessions.
Step 3	show l2tp tunnel [all packets [ipv6] state summary transport] [id local-tunnel-id local-name local-tunnel-name remote-tunnel-name] remote-name remote-tunnel-name local-tunnel-name]	Displays details about L2TP tunnels.

	Command or Action	Purpose
	<p>Example:</p> <pre>Router# show l2tp tunnel packets ipv6</pre>	
Step 4	<p>show l2tun session [l2tp pptp] [all <i>[filter]</i> brief <i>[filter]</i> [hostname] circuit <i>[filter]</i> [hostname] interworking <i>[filter]</i> [hostname] packets ipv6] <i>[filter]</i> sequence <i>[filter]</i> state <i>[filter]</i>]</p> <p>Example:</p> <pre>Router# show l2tun session packets ipv6</pre>	Displays the current state of Layer 2 sessions and protocol information about L2TP control channels.
Step 5	<p>show vpdn session [l2f l2tp pptp] [all packets [ipv6] sequence state <i>[filter]</i>]</p> <p>Example:</p> <pre>Router# show vpdn session packets ipv6</pre>	Displays session information about active Layer 2 sessions for a virtual private dialup network (VPDN).
Step 6	<p>show vpdn tunnel [l2f l2tp pptp] [all <i>[filter]</i> packets ipv6] <i>[filter]</i> state <i>[filter]</i> summary <i>[filter]</i> transport<i>[filter]</i>]</p> <p>Example:</p> <pre>Router# show vpdn tunnel packets ipv6</pre>	Displays information about active Layer 2 tunnels for a VPDN.

Configuration Examples for Broadband IPv6 Counter Support at LNS

Examples: Verifying Broadband IPv6 Counter Support at the LNS

Example: show l2tp session Command

The **show l2tp session** command used with the **packets** and **ipv6** keywords displays information about IPv6 packets and byte counts in an L2TP session.

```
Router# show l2tp session packets ipv6

L2TP Session Information Total tunnels 1 sessions 1

LocID      RemID      TunID      Pkts-In    Pkts-Out   Bytes-In   Bytes-Out
-----
16791      53352     27723     30301740   30301742   20159754280 20523375360
```

Example: show l2tp tunnel Command

The **show l2tp tunnel** command used with the **packets** and **ipv6** keywords displays information about IPv6 packet statistics and byte counts in L2TP tunnels.

```
Router# show l2tp tunnel packets ipv6

L2TP Tunnel Information Total tunnels 1 sessions 1
LocTunID  Pkts-In  Pkts-Out  Bytes-In  Bytes-Out
-----
27723     63060379 63060383 39400320490 40157045438
```

Example: show l2tun session Command

The **show l2tun session** command used with the **packets** and **ipv6** keywords displays information about IPv6 packet statistics and byte counts in an L2TUN session.

```
Router# show l2tun session packets ipv6

L2TP Session Information Total tunnels 1 sessions 1
LocID      RemID      TunID      Pkts-In    Pkts-Out   Bytes-In   Bytes-Out
-----
16791      53352     27723     31120707   31120708   21285014938 21658462236
```

Example: show vpdn session Command

The **show vpdn session** command used with the **l2tp**, **packets**, and **ipv6** keywords displays session information about IPv6 packet statistics and byte counts in an active layer 2 session for a VPDN.

```
Router# show vpdn session l2tp packets ipv6

L2TP Session Information Total tunnels 1 sessions 1
LocID      RemID      TunID      Pkts-In    Pkts-Out   Bytes-In   Bytes-Out
-----
16791      53352     27723     35215536   35215538   22616342688 23038929320
```

Example: show vpdn tunnel Command

The `show vpdn tunnel` command used with the `l2tp`, `packets`, and `ipv6` keywords displays session information about IPv6 packet statistics and byte counts in an active layer 2 tunnel for a VPDN.

```
Device# show vpdn tunnel l2tp packets ipv6
L2TP Tunnel Information Total tunnels 1 sessions 1
LocTunID  Pkts-In    Pkts-Out    Bytes-In    Bytes-Out
27723     61422447    61422451    37149801922 37886871686
```

Additional References

Related Documents

Related Topic	Document Title
IPv6 addressing and connectivity	<i>IPv6 Configuration Guide</i>
Cisco IOS commands	Cisco IOS Master Commands List, All Releases
IPv6 commands	Cisco IOS IPv6 Command Reference
Cisco IOS IPv6 features	Cisco IOS IPv6 Feature Mapping

Standards and RFCs

Standard/RFC	Title
RFCs for IPv6	

MIBs

MIB	MIBs Link
	To locate and download MIBs for selected platforms, Cisco IOS releases, and feature sets, use Cisco MIB Locator found at the following URL: http://www.cisco.com/go/mibs

Technical Assistance

Description	Link
The Cisco Support and Documentation website provides online resources to download documentation, software, and tools. Use these resources to install and configure the software and to troubleshoot and resolve technical issues with Cisco products and technologies. Access to most tools on the Cisco Support and Documentation website requires a Cisco.com user ID and password.	http://www.cisco.com/cisco/web/support/index.html

Feature Information for Broadband IPv6 Counter Support at LNS

The following table provides release information about the feature or features described in this module. This table lists only the software release that introduced support for a given feature in a given software release train. Unless noted otherwise, subsequent releases of that software release train also support that feature.

Use Cisco Feature Navigator to find information about platform support and Cisco software image support. To access Cisco Feature Navigator, go to www.cisco.com/go/cfn. An account on Cisco.com is not required.

Table 38: Feature Information for Broadband IPv6 Counter Support at LNS

Feature Name	Releases	Feature Information
Broadband IPv6 Counter Support at LNS	Cisco IOS XE Release 2.6	This feature provides support for broadband PPP IPv6 sessions at the L2TP LNS. The sessions are forwarded by LAC using layer 2 tunneling protocol L2TP over IPv4. The following commands were introduced or modified: show l2tp session , show l2tp tunnel , show l2tun session , show vpdn session , show vpdn tunnel .



PPP IP Unique Address and Prefix Detection

The PPP IP Unique Address and Prefix Detection feature checks the uniqueness of IPv4 addresses and IPv6 prefixes on the broadband remote access server (BRAS). PPP disconnects the session if it detects a duplicate IPv4 address and IPv6 prefix.

- [Finding Feature Information, page 353](#)
- [Information About PPP IP Unique Address and Prefix Detection, page 353](#)
- [How to Configure PPP IP Unique Address and Prefix Detection, page 354](#)
- [Configuration Examples for PPP IP Unique Address and Prefix Detection, page 355](#)
- [Additional References, page 356](#)
- [Feature Information for PPP IP Unique Address and Prefix Detection, page 357](#)

Finding Feature Information

Your software release may not support all the features documented in this module. For the latest caveats and feature information, see [Bug Search Tool](#) and the release notes for your platform and software release. To find information about the features documented in this module, and to see a list of the releases in which each feature is supported, see the feature information table.

Use Cisco Feature Navigator to find information about platform support and Cisco software image support. To access Cisco Feature Navigator, go to www.cisco.com/go/cfn. An account on Cisco.com is not required.

Information About PPP IP Unique Address and Prefix Detection

- IPv6 checks if the prefix is unique when it is installed on an interface. If the prefix installation fails, PPP disconnects the session.
- PPP also checks if the IPv4 address is unique. PPP disconnects the session if a duplicate IPv4 address is detected.

How to Configure PPP IP Unique Address and Prefix Detection

Perform this task to configure the PPP IP Unique Address and Prefix Detection feature.

SUMMARY STEPS

1. **enable**
2. **configure terminal**
3. **interface virtual-template** *interface-number*
4. **ppp ipcp address required**
5. **ppp ipcp address unique**
6. **ppp ipv6cp address unique**
7. **ppp timeout ncp** *seconds*
8. **exit**
9. **ppp ncp override local**
10. **end**

DETAILED STEPS

	Command or Action	Purpose
Step 1	enable Example: Router> enable	Enables privileged EXEC mode. <ul style="list-style-type: none"> • Enter your password if prompted.
Step 2	configure terminal Example: Router# configure terminal	Enters global configuration mode.
Step 3	interface virtual-template <i>interface-number</i> Example: Router(config)# interface virtual-template 7	Selects the Virtual Template interface and enters interface configuration mode.
Step 4	ppp ipcp address required Example: Router(config-if)# ppp ipcp address required	PPP disconnects the peer if no IP address is negotiated.

	Command or Action	Purpose
Step 5	<p>ppp ipcp address unique</p> <p>Example:</p> <pre>Router(config-if)# ppp ipcp address unique</pre>	PPP disconnects the peer if the IP address is already in use.
Step 6	<p>ppp ipv6cp address unique</p> <p>Example:</p> <pre>Router(config-if)# ppp ipv6cp address unique</pre>	PPP disconnects the peer if the IPv6 prefix is already in use.
Step 7	<p>ppp timeout ncp <i>seconds</i></p> <p>Example:</p> <pre>Router(config-if)# ppp timeout ncp 30</pre>	PPP sets the maximum time in seconds to wait for the network layer to negotiate.
Step 8	<p>exit</p> <p>Example:</p> <pre>Router(config-if)# exit</pre>	Exits interface configuration mode and returns to global configuration mode.
Step 9	<p>ppp ncp override local</p> <p>Example:</p> <pre>Router(config)# ppp ncp override local</pre>	PPP overrides the local dual-stack configuration, checks the permitted Network Control Programs (NCP), and rejects user-initiated NCP negotiation.
Step 10	<p>end</p> <p>Example:</p> <pre>Router(config)# end</pre>	Exits global configuration mode and returns to privileged EXEC mode.

Configuration Examples for PPP IP Unique Address and Prefix Detection

Example PPP Unique Address and Prefix Detection

To enable the PPP IP Unique Address and Prefix Detection feature, use the following configuration.

```
Router# configure terminal
Router(config)# interface virtual-template 7
```

```

Router(config-if)# ppp ipcp address required
Router(config-if)# ppp ipcp address unique
Router(config-if)# ppp ipv6cp address unique

Router(config-if)# ppp timeout ncp 30
Router(config-if)# exit
Router(config)# ppp ncp override local
Router(config)# end

```

Additional References

Related Documents

Related Topic	Document Title
Cisco IOS commands	Cisco IOS Master Commands List, All Releases
Broadband Access Aggregation and DSL commands	<i>Cisco IOS Broadband Access Aggregation and DSL Command Reference</i>

Standards

Standard	Title
None	--

MIBs

MIB	MIBs Link
None	To locate and download MIBs for selected platforms, Cisco software releases, and feature sets, use Cisco MIB Locator found at the following URL: http://www.cisco.com/go/mibs

RFCs

RFC	Title
None	--

Technical Assistance

Description	Link
The Cisco Support and Documentation website provides online resources to download documentation, software, and tools. Use these resources to install and configure the software and to troubleshoot and resolve technical issues with Cisco products and technologies. Access to most tools on the Cisco Support and Documentation website requires a Cisco.com user ID and password.	http://www.cisco.com/cisco/web/support/index.html

Feature Information for PPP IP Unique Address and Prefix Detection

The following table provides release information about the feature or features described in this module. This table lists only the software release that introduced support for a given feature in a given software release train. Unless noted otherwise, subsequent releases of that software release train also support that feature.

Use Cisco Feature Navigator to find information about platform support and Cisco software image support. To access Cisco Feature Navigator, go to www.cisco.com/go/cfn. An account on Cisco.com is not required.

Table 39: Feature Information for PPP IP Unique Address and Prefix Detection

Feature Name	Releases	Feature Information
PPP IP Unique Address and Prefix Detection	Cisco IOS XE Release 3.2S	<p>The PPP IP Unique Address and Prefix Detection feature checks the uniqueness of IPv4 address and IPv6 prefix on the BRAS. PPP disconnects the session if it detects a duplicate IPv4 address and IPv6 prefix.</p> <p>The following commands were introduced: ppp ipv6cp address unique, ppp ncp override local.</p>



PPP IPv4 Address Conservation in Dual Stack Environments

The IPv4 Address Conservation in Dual Stack Environments feature enables service providers with a limited pool of IPv4 addresses to manage a large number of subscribers and conserve this address pool. A dual-stack environment is one in which service providers have both IPv4 addresses and IPv6 prefixes in their networks. A subscriber requests an IPv4 address, which it releases after a defined time interval. This same address can then be reassigned to any other subscriber, thereby allowing service providers to conserve the available IPv4 address space.

- [Finding Feature Information, page 359](#)
- [Prerequisites for PPP IPv4 Address Conservation in Dual Stack Environments, page 360](#)
- [Restrictions for PPP IPv4 Address Conservation in Dual Stack Environments, page 360](#)
- [Information About PPP IPv4 Address Conservation in Dual Stack Environments, page 360](#)
- [How to Configure IPv4 Address Conservation in Dual Stack Environments, page 362](#)
- [Configuration Examples for PPP IPv4 Address Conservation in Dual Stack Environments, page 363](#)
- [Additional References, page 363](#)
- [Feature Information for PPP IPv4 Address Conservation in Dual Stack Environments, page 364](#)

Finding Feature Information

Your software release may not support all the features documented in this module. For the latest caveats and feature information, see [Bug Search Tool](#) and the release notes for your platform and software release. To find information about the features documented in this module, and to see a list of the releases in which each feature is supported, see the feature information table.

Use Cisco Feature Navigator to find information about platform support and Cisco software image support. To access Cisco Feature Navigator, go to www.cisco.com/go/cfn. An account on Cisco.com is not required.

Prerequisites for PPP IPv4 Address Conservation in Dual Stack Environments

- You need to understand authentication, authorization, and accounting (AAA) and PPP before configuring IPv4 address conservation.
- A RADIUS server must be configured for centralized AAA.
- The customer premises equipment (CPE) must support a dual-stack environment and must have the intelligence to trigger the release of any IPv4 addresses not being used by applications at the CPE for a specified interval.
- The broadband remote access server (BRAS) must be able to send an IPv4 address request from a CPE device to the RADIUS server, a notification to the RADIUS server when an IPv4 address is allocated to the CPE device, and a notification to the RADIUS server when the CPE device releases the IPv4 address.
- The RADIUS server must be configured to assign only IPv6 prefixes during link control protocol (LCP) authentication, assign only IPv4 addresses when the BRAS sends an address allocation request, and return released IPv4 addresses to the free pool of addresses in response to the BRAS IPv4 address-release notification.

Restrictions for PPP IPv4 Address Conservation in Dual Stack Environments

A local IP address pool must not be configured on the BRAS.

Information About PPP IPv4 Address Conservation in Dual Stack Environments

IPv4 Address Conservation in Dual Stack Environments

A subscriber in the service provider's network receives an IPv6 prefix from the RADIUS server in the initial authentication access-accept response. The broadband remote access server (BRAS) performs a uniqueness check to ensure that the IPv6 prefix has not been assigned to another subscriber. The BRAS then receives an Internet Protocol Control Protocol (IPCP) request for an IPv4 address from the subscriber. Next, the BRAS adds a number of attributes including the subscriber username and the Cisco vendor-specific attribute (VSA) for IPv4 address saving to the request, and sends this information to the RADIUS server. The VSA information tells the RADIUS server that this is a request for an existing session and the username identifies the subscriber making the request. The RADIUS server then sends an IPv4 address in the access-accept response. The BRAS checks that the IPv4 address that is to be assigned is not being used by any other subscriber. If a duplicate address is found, the session is torn down, otherwise the session is authorized. If the subscriber sends another request for an IPv4 address without terminating the earlier session, the BRAS does not send this request to

the RADIUS server; instead, it uses the IPv4 address returned in the previous authorization exchange. When the subscriber terminates the session, the BRAS releases the IPv4 address and resets the authorization flag for this subscriber. This ensures that if the same subscriber requests an IPv4 address again, the request will be forwarded to the RADIUS server.

In addition, we recommend that you configure the following features on the BRAS. For a detailed description of the commands required to configure these features, see the [Cisco IOS Broadband Access Aggregation and DSL Command Reference](#).

**Note**

None of these features are mandatory for the IPv4 address conservation feature to work.

PPP IP Unique Address and Prefix Detection

The PPP IP Unique Address and Prefix Detection feature checks the uniqueness of IPv4 addresses and IPv6 prefixes on the broadband remote access server (BRAS). PPP disconnects the session if it detects a duplicate IPv4 address and IPv6 prefix.

PPP Local NCP Override

The PPP Local NCP Override feature configures the broadband remote access server (BRAS) to track the attributes received in the authorization from the RADIUS server, verifies the permitted Network Control Protocol (NCP), rejects the current NCP, and overrides the local dual-stack configuration.

AAA Delayed Accounting

The AAA Delayed Accounting feature delays the generation of accounting “start” records until the user IP address is established. When this feature is configured, the broadband remote access server (BRAS) sends an accounting “start” record to the RADIUS server when the appropriate network control protocol (NCP) is established.

How to Configure IPv4 Address Conservation in Dual Stack Environments

Configuring PPP IPv4 Address Conservation in Dual Stack Environments

Before You Begin

SUMMARY STEPS

1. enable
2. configure terminal
3. ppp ip address-save aaa-acct-vsa *vsa-string*
4. end
5. debug ppp ip address-save

DETAILED STEPS

	Command or Action	Purpose
Step 1	enable Example: Router> enable	Enables privileged EXEC mode. • Enter your password if prompted.
Step 2	configure terminal Example: Router# configure terminal	Enters global configuration mode.
Step 3	ppp ip address-save aaa-acct-vsa <i>vsa-string</i> Example: Router(config)# ppp ip address-save aaa-acct-vsa enable	Enables IPv4 address conservation and defines the vendor-specific attribute value.
Step 4	end Example: Router(config)# end	Exits global configuration mode and returns to privileged EXEC mode.
Step 5	debug ppp ip address-save Example: Router# debug ppp ip address-save	Displays debugging information for the IPv4 address conservation feature.

Configuration Examples for PPP IPv4 Address Conservation in Dual Stack Environments

Example: PPP IPv4 Address Conservation in Dual Stack Environments

The following example shows how to enable the PPP IPv4 Address Conservation in Dual Stack Environments feature.

```
Router> enable
Router# configure terminal
Router(config)# ppp ip address-save aaa-acct-vsa enable
Router(config)# end
```

Additional References

Related Documents

Related Topic	Document Title
Cisco IOS commands	Cisco IOS Master Commands List, All Releases
Broadband Access Aggregation and DSL commands	Cisco IOS Broadband Access Aggregation and DSL Command Reference

Technical Assistance

Description	Link
The Cisco Support and Documentation website provides online resources to download documentation, software, and tools. Use these resources to install and configure the software and to troubleshoot and resolve technical issues with Cisco products and technologies. Access to most tools on the Cisco Support and Documentation website requires a Cisco.com user ID and password.	http://www.cisco.com/cisco/web/support/index.html

Feature Information for PPP IPv4 Address Conservation in Dual Stack Environments

The following table provides release information about the feature or features described in this module. This table lists only the software release that introduced support for a given feature in a given software release train. Unless noted otherwise, subsequent releases of that software release train also support that feature.

Use Cisco Feature Navigator to find information about platform support and Cisco software image support. To access Cisco Feature Navigator, go to www.cisco.com/go/cfn. An account on Cisco.com is not required.

Table 40: Feature Information for PPP IPv4 Address Conservation In Dual Stack Environments

Feature Name	Releases	Feature Information
PPP IPv4 Address Conservation in Dual Stack Environments	Cisco IOS XE Release 3.5S	<p>The IPv4 Address Conservation in Dual Stack Environments feature enables service providers with a limited pool of IPv4 addresses to manage a large number of subscribers and conserve this address pool. A subscriber is allocated an IPv4 address, which it releases after a defined time interval. This same address can then be reassigned to another subscriber that requests an IPv4 address.</p> <p>The following commands were introduced: debug ip address-save, ppp ip address-save aaa-acct-vs-a.</p>



TR-069 Agent

The digital subscriber line (DSL) Forum's TR-069, CPE WAN Management Protocol (CWMP), is used for communications between a customer premise equipment (CPE) and an auto-configuration server (ACS). The TR-069 Agent feature manages a collection of CPEs, with the primary capability for auto-configuration and dynamic service provisioning, software image management, status and performance monitoring and diagnostics.

- [Finding Feature Information, page 365](#)
- [Limitations for the TR-069 Agent, page 365](#)
- [Prerequisites for the TR-069 Agent, page 367](#)
- [Information About the TR-069 Agent, page 367](#)
- [How to Configure and Enable the TR-069 Agent, page 373](#)
- [Configuration Examples for TR-069 Agent, page 381](#)
- [Additional References for TR-069 Agent, page 382](#)
- [Feature Information for TR-069 Agent, page 383](#)
- [Glossary, page 384](#)

Finding Feature Information

Your software release may not support all the features documented in this module. For the latest caveats and feature information, see [Bug Search Tool](#) and the release notes for your platform and software release. To find information about the features documented in this module, and to see a list of the releases in which each feature is supported, see the feature information table.

Use Cisco Feature Navigator to find information about platform support and Cisco software image support. To access Cisco Feature Navigator, go to www.cisco.com/go/cfn. An account on Cisco.com is not required.

Limitations for the TR-069 Agent

The following table provide the limitations of the parameters in TR-069.

Table 41: TR-069 Parameters

TR-069 Parameter	Expected Value	Supported on Cisco ISR G2	Supported on Cisco 4451 G2
InternetGatewayDevice. WANDevice2. WANCommonInterfaceConfig	Time	No	No
Internet gateway device. WAN device2. WAN common interface config enabled. For Internet registration entry for Internet gateway device. WAN device. WAN common Interface configuration does not include the parameter enabled for Internet.	True or Flase	No	No
InternetGatewayDevice. WANDevice2. WANCommonInterfaceConfig	Version	Yes	No
InternetGatewayDevice. WANDevice2. WANCommonInterfaceConfig	Populate the details	Yes	Yes
WAN access type is DSL (Internet gateway device. WAN device2. WAN common interface configuration. WAN access type) The WAN DSL interface configuration data is populates when the WAN access type is Ethernet (Internet Gateway device. WAN device. WAN common interface configuration interface config. WAN access type). The WAN Ethernet interface configuration date populates.	Populate the details	Yes	Yes
InternetGatewayDevice. WANDevice2. WANCommonInterfaceConfig	MTU value	No	No
InternetGatewayDevice. WANDevice2. WANCommonInterfaceConfig	MTU value	No	No

TR-069 Parameter	Expected Value	Supported on Cisco ISR G2	Supported on Cisco 4451 G2
Internet gateway device. Layer 3 forwarding. Forwarding 1. MTU registration entry for Internet gateway device. Layer 3 forwarding. Forwarding does not include the parameter MTU.	MTU value	No	No
Set parameter values- Internet gateway device. Time. NTP server 5 in Cisco 4451, config t, archive, path boot flash should be configured to set the value in Cisco ISR G2; only one storage path and it is the flash memory.	ntp server 100.12.12.1	YES (no archive)	YES (configure archive)

Prerequisites for the TR-069 Agent

The CPE should have an IP address and a WAN connection should be established to access the ACS.

Information About the TR-069 Agent

TR-069 Agent

The TR-069 Agent allows an ACS to provision a CPE or collection of CPEs. The provisioning mechanism includes specific provisioning parameters and a general mechanism for adding vendor-specific provisioning capabilities as needed. The identification mechanisms included in the protocol allow CPE provisioning based either on the requirements of each specific CPE, or on collective criteria such as the CPE vendor, model, software version, or other criteria.

The provisioning mechanism allows CPE provisioning at the time of initial connection to the broadband access network and the ability to re-provision at any subsequent time. This includes support for asynchronous ACS-initiated re-provisioning of a CPE.

The TR-069 Agent also supports image upgrade, configuration application, file downloads, configuration and log file uploads, and CPE monitoring.

**Note**

The TR-069 Agent CPE devices must be set up and enabled for TR-069. An ACS used to communicate with the CPE must be TR-069 compliant in order to enable the TR-069 Agent.

RPC Support

The following remote procedure calls (RPCs) supported with the TR-069 Agent:

- Standard RPCs
 - GetRPCMethods
 - SetParameterValues
 - GetParameterValues
 - GetParameterNames
 - SetParameterAttributes
 - GetParameterAttributes
 - AddObject
 - DeleteObject
 - Reboot
 - Download
 - Upload
- Vendor RPCs
 - X_00000C_SetConfiguration
 - X_00000C_ShowStatus

CWMP Vendor Profile Schema

The following details the CWMP vendor profile schema:

- For SetConfiguration,

```
<cwmp:X_00000C_SetConfiguration>
<ErrorOption> rollback </ErrorOption>
<Target> {running-config | startup-config} </Target>
<ConfigCommandBlock> block of clis separated by newline [\n] character </ConfigCommandBlock>
<ConfigCommandList array of strings[1..unbounded] each of length 256>
<string> IOS Configuration command 1 </string>
<string> IOS Configuration command 2 </string>
</ConfigCommandList>
<ParameterKey> parameterkey </ParameterKey>
</cwmp:X_00000C_SetConfiguration>
```

```
ErrorOption => string with length 64
Target => string with length 64
```

On success,

```
<X_00000C_SetConfigurationResponse>
<Status>0</Status>
</X_00000C_SetConfigurationResponse>
```

On failure,

```
<SOAP:Fault>
<SOAP:faultcode>Client</SOAP:faultcode>
<SOAP:faultstring>CWMP fault</SOAP:faultstring>
<SOAP:detail>
<cwmp:Fault>
<FaultCode></FaultCode>
<FaultString></FaultString>

<cwmp:X_00000C_SetConfigurationFault>
<Command>IOS Configuration command that failed</Command>
<FaultCode>parse_cmd() return value</FaultCode>
</cwmp:X_00000C_SetConfigurationFault>

<cwmp:X_00000C_SetConfigurationFault>
<Command>IOS Configuration command that failed</Command>
<FaultCode>parse_cmd() return value</FaultCode>
</cwmp:X_00000C_SetConfigurationFault>

</cwmp:Fault>
</SOAP:detail>
</SOAP:Fault>
```

- For ShowStatus,

```
<cwmp:X_00000C_ShowStatus>
<ExecCommandList array of strings[1..unbounded] each of length 256 >
<string> IOS Exec command 1 </string>
<string> IOS Exec command 2 </string>
<string> IOS Exec command 3 </string>
</ExecCommandList>
</cwmp:X_00000C_ShowStatus>
```

On success,

```
<cwmp:X_00000C_ShowStatusResponse>
<ExecResponseList array of ExecResponseStruct [1..unbounded]>
<ExecResponseStruct>
<Command> IOS Exec command 1 </Command>
<Response> output of command 1</Response>
</ExecResponseStruct>

<ExecResponseStruct>
<Command> IOS Exec command 2 </Command>
<Response> output of command 2 </Response>
</ExecResponseStruct>

<ExecResponseStruct>
<Command> IOS Exec command 3 </Command>
<Response>output of command 3</Response>
</ExecResponseStruct>

</ExecResponseList>
</cwmp:X_00000C_ShowStatusResponse>
```

On failure,

```
<SOAP:Fault>
<SOAP:faultcode>Client</SOAP:faultcode>
<SOAP:faultstring>CWMP fault</SOAP:faultstring>
<SOAP:detail>
```

```
<cwmp:Fault>
<FaultCode></FaultCode>
<FaultString></FaultString>
</cwmp:Fault>
</SOAP:detail>
</SOAP:Fault>
```

HTTP Digest Authentication Support

The TR-069 Agent uses HTTP as the transport and needs support for digest authentication from the HTTP client infrastructure.



Note

This feature is not a TR-069 Agent-exclusive feature and can be used in other scenarios to configure HTTP Digest Authentication Support.

HTTP Cookie Support Per RFC2965

A cookie is a piece of HTTP state information generated and sent by an HTTP server in response to an HTTP request. The HTTP client returns the cookie containing the state information back to the HTTP server in its next HTTP request. This scenario is used to create a stateful session with HTTP requests and responses. The TR-069 Agent uses HTTP as the transport and needs support for both Netscape cookies and RFC 2965 in HTTP client infrastructure.



Note

This feature is not a TR-069 Agent-exclusive feature and can be used in other scenarios to clear, monitor and troubleshoot HTTP cookies.

Device Gateway Association and Port Mapping Support

Device Gateway Association

The CPE WAN Management Protocol (CWMP) can be used to remotely manage customer premise equipment (CPE) devices that are connected over a LAN through a gateway. If Auto Configuration Server (ACS) manages both the Device and the Gateway through which the device is connected, ACS determines the identity of the gateway by checking the device gateway association information. The ACS with the device gateway association profile can identify the end devices behind each gateway. The device gateway association constitutes Annex F (previously part of TR-111), part of the TR-069 standard. The mechanism defined for device gateway association relies on the Device's use of Dynamic Host Configuration Protocol (DHCP) Option 125. The end devices will pass on their identity to the gateway via vendor-specific DHCP option. When the gateway receives this information, the gateway populates the ManageableDevice table containing identity information for each device on its LAN. The parameters, which are supported on the gateway as part of device gateway association is as follows:

- **InternetGatewayDevice.ManagementServer.ManageableDeviceNumberOfEntries**
- **InternetGatewayDevice.ManagementServer.ManageableDevice.{i}**

- **ManufacturerOUI**
- **ProductClass**
- **SerialNumber**

The device gateway association functionality does not support configuring IP addresses manually on the end devices. The IP addresses are assigned to the end devices via DHCP by the gateway. You must configure **renew deny unknown** command under the DHCP server configuration to initiate the DHCP discovery process for the end devices after a gateway reload.

Figure 22: Device-Gateway Association using DHCP Discover

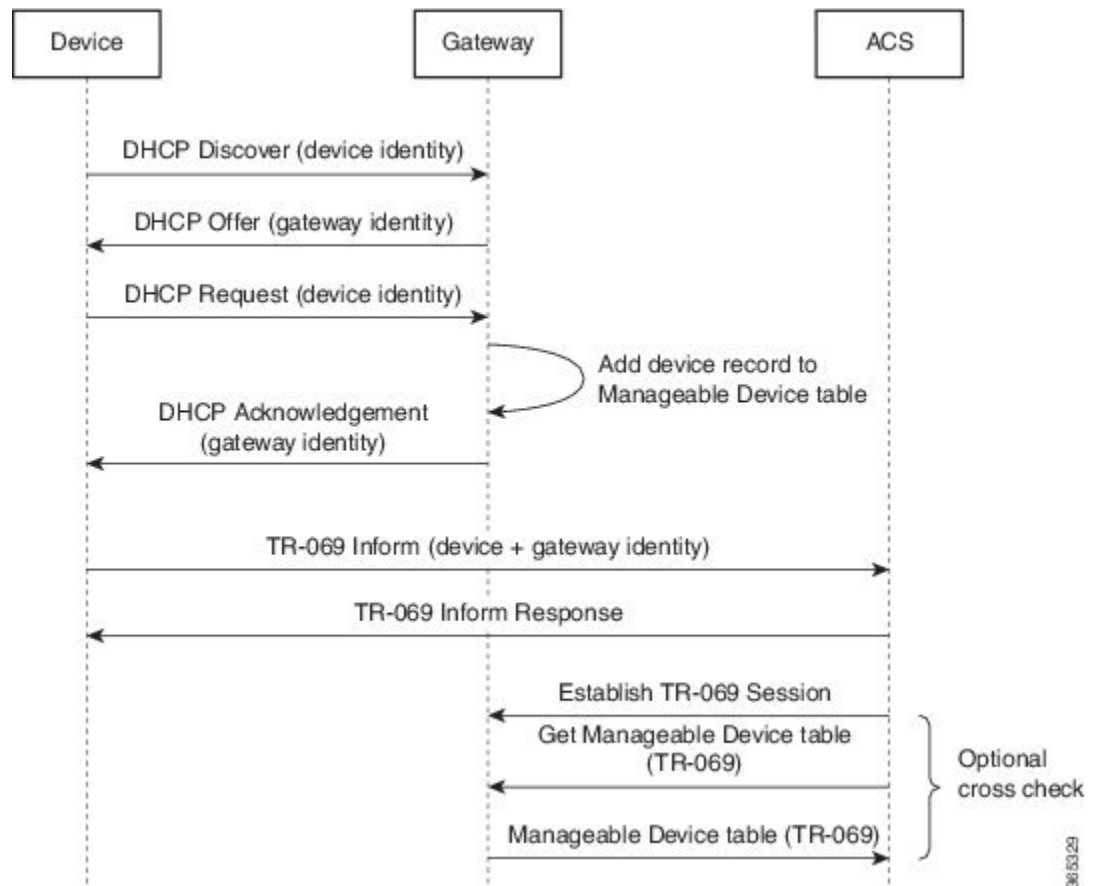

The following example shows how to set up the Device-Gateway Association and Port Mapping feature via a Dynamic Host Configuration Protocol (DHCP) on VLAN interface:

```

ip dhcp excluded-address 15.15.15.1
!
ip dhcp pool NET-POOL1
network 15.15.15.0 255.255.255.0
default-router 15.15.15.1
lease 0 0 5
renew deny unknown
end
interface Vlan102
 ip address pool NET-POOL1
end
  
```

Port Mapping Support

The CPE WAN Management Protocol (CWMP) can be used to remotely manage customer premise equipment (CPE) devices that are connected via a LAN through a network address translation (NAT) gateway. This can be achieved by making use of the PortMapping functionality. This feature helps in maintaining the privacy of the IP addresses of the end devices as the communication happens with the auto-configuration server (ACS) in the public domain. The gateway supports the following CWMP parameters:

- **InternetGatewayDevice.WANDevice.{i}.WANConnectionDevice.{i}.WANIPConnection.{i}.PortMappingNumberOfEntries**
- **InternetGatewayDevice.WANDevice.{i}.WANConnectionDevice.{i}.WANIPConnection.{i}.Port-Mapping.{i}**.
 - **PortMappingEnabled**
 - **PortMappingLeaseDuration**
 - **RemoteHost**
 - **ExternalPort**
 - **InternalPort**
 - **PortMappingProtocol**
 - **InternalClient**
 - **PortMappingDescription**
- **InternetGatewayDevice.WANDevice.{j}.WANConnectionDevice.{j}.WANPPP-Connection.{j}.PortMappingNumberOfEntries**
- **InternetGatewayDevice.WANDevice.{i}.WANConnectionDevice.{i}.WANPPP-Connection.{i}.PortMapping.{i}**.
 - **PortMappingEnabled**
 - **PortMappingLeaseDuration**
 - **RemoteHost**
 - **ExternalPort**
 - **InternalPort**
 - **PortMappingProtocol**
 - **InternalClient**
 - **PortMappingDescription**

**Note**

The ACS must provide values for the mandatory parameters—**ExternalPort**, **InternalPort**, **PortMappingProtocol**, and **InternalClient**—to the gateway for adding the port mapping for an end device. There is no support to limit the portmapping to a particular host using **RemoteHost** parameter.

Figure 23: Connection request via a NAT Gateway using PortMapping table

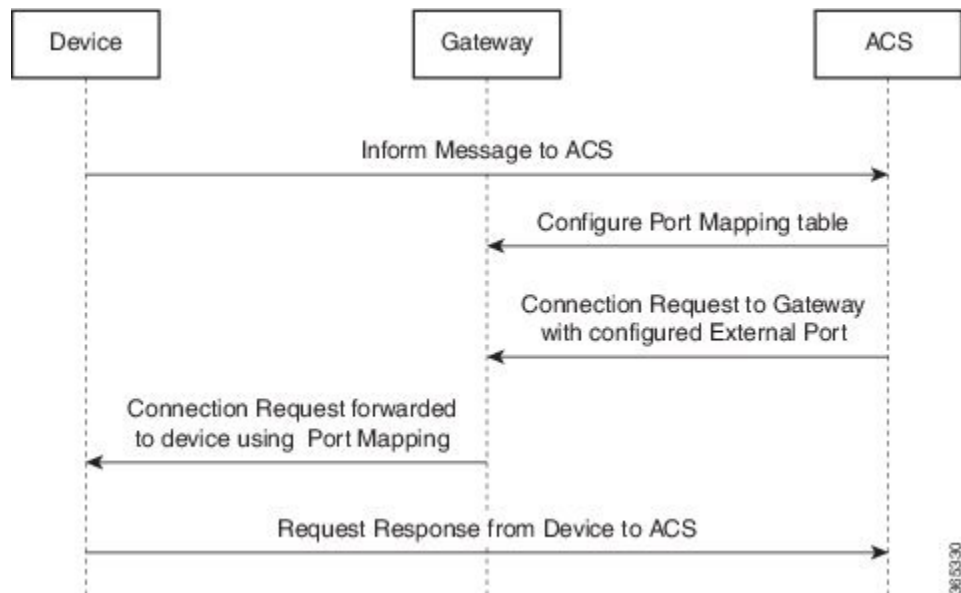

The following is an example Port Mapping Support on a device configured as a gateway and ACS.

For the below parameters configured on ACS,

```

Destination IP (InternalClient) - 15.15.15.2
Source port (ExternalPort) - 9000
Destination port (InternalPort) - 7547
PortMappingProtocol - TCP
  
```

the following NAT command is configured on the gateway:

```
ip nat inside source static tcp 15.15.15.2 7547 10.194.145.170 9000 extendable
```

10.194.145.170 is the RemoteHost and the IP address of the device or gateway provisioned by ACS. This is the IP address corresponding to the interface with the configuration **cwmp wan default** command.

How to Configure and Enable the TR-069 Agent

Setting Up the CPE to Communicate with the ACS

Perform this task and the following tasks to configure and enable the TR-069 agent on the CPE. If an Ethernet or Serial interface is used to communicate with ACS, these tasks need not be performed manually because the tasks are automated by using the AutoInstall feature. For more information on the AutoInstall feature, refer to [Using AutoInstall to Remotely Configure Cisco Networking Devices](#). For an example on configuring

CWMP with the autoinstall feature, see the *Example: Configuring and Enabling CWMP using the Autoinstall feature* section.

Before You Begin

If the ACS URL is an HTTP URL, enable the Cisco IOS HTTP Server using the **ip http server** command. If the ACS URL is an HTTPS URL, enable the Cisco IOS HTTP Secure Server using the **ip http secure-server** command. For more information about the **ip http server** and **ip http secure-server** commands, refer to the *Cisco IOS Network Management Command Reference*.

SUMMARY STEPS

1. **enable**
2. **configure terminal**
3. **cwmp agent**
4. **management server url** *acs-url*
5. **management server password** [*encryption-type* | *cleartext-password*] *passwd*
6. **provision code** *code-string*
7. **exit**
8. **interface** *type number*
9. **cwmp wan**
10. **cwmp wan default**
11. **exit**
12. **cwmp agent**
13. **enable download**
14. **session retry limit** *session-count*
15. **request outstanding** *request-count*
16. **parameter change notify interval** *time-interval*
17. **end**

DETAILED STEPS

	Command or Action	Purpose
Step 1	enable Example: Device> enable	Enables privileged EXEC mode. <ul style="list-style-type: none"> • Enter your password if prompted.
Step 2	configure terminal Example: Device# configure terminal	Enters global configuration mode.

	Command or Action	Purpose
Step 3	cwmp agent Example: Device(config)# cwmp agent	Enables TR-069 Agent configuration mode.
Step 4	management server url <i>acs-url</i> Example: Device(config-cwmp)# management server url http://172.25.117.78:7547/acs Example: Device(config-cwmp)# management server url https://172.25.117.78:7547/acs	Specifies the HTTP/HTTPS URL to reach the ACS. This URL is used by the CPE to establish the TR-069 session with the ACS.
Step 5	management server password [<i>encryption-type</i> <i>cleartext-password</i>] <i>passwd</i> Example: Device(config-cwmp)# management server password 0 cisco	Specifies the CPE password that is used in the authentication phase. <ul style="list-style-type: none"> This password will be provided to the ACS when the CPE is challenged for credential as part of authentication during the session establishment.
Step 6	provision code <i>code-string</i> Example: Device(config-cwmp)# provision code ABCD	Specifies the provision code to be used by the CPE.
Step 7	exit Example: Device(config-cwmp)# exit	Exits TR-069 Agent configuration mode and returns to global configuration mode.
Step 8	interface <i>type number</i> Example: Device# interface serial 0/0	Enters interface configuration mode.
Step 9	cwmp wan Example: Device(config-if)# cwmp wan	(Optional) Defines the WAN interfaces on the CPE. Note Any interface without this command is considered a LAN interface by TR-069 protocol. There can be multiple WAN and LAN interfaces configured on the CPE. By default, an ATM interface on the CPE will be considered a WAN interface by the TR-069 protocol.
Step 10	cwmp wan default Example: Device(config-if)# cwmp wan default	Defines the default WAN interfaces on the CPE device.

	Command or Action	Purpose
		Note Among the multiple WAN interfaces, there can be only one default WAN interface in which the TR-069 communication could happen. If you try to configure this command on multiple interfaces, only the latest configuration will be active and the previous default WAN interface will become a WAN interface, ensuring only one interface is the default at any point in time.
Step 11	exit Example: Device(config-if)# exit	Exits interface configuration mode and returns to global configuration mode.
Step 12	cwmp agent Example: Device(config)# cwmp agent	Enables TR-069 Agent configuration mode.
Step 13	enable download Example: Device(config-cwmp)# enable download	(Optional) Enables the CPE to permit a software download. By default, this command is disabled.
Step 14	session retry limit <i>session-count</i> Example: Device(config-cwmp)# session retry limit 10	(Optional) Sets the session retry count whenever the TR-069 session establishment fails with the ACS. <ul style="list-style-type: none"> • The range for the session count argument is 0 to 15. • The default value is 11.
Step 15	request outstanding <i>request-count</i> Example: Device(config-cwmp)# request outstanding 6	(Optional) Sets the count for the number of requests that can be sent by CPE to ACS without receiving the acknowledgement. <ul style="list-style-type: none"> • The range for the request count argument is 0 to 10. • The default value is 5.
Step 16	parameter change notify interval <i>time-interval</i> Example: Device(config-cwmp)# parameter change notify interval 75	(Optional) Sets the time interval, in seconds, for the parameter change notifications. <ul style="list-style-type: none"> • The range for the time interval argument is 15 to 300. • The default value is 60.
Step 17	end Example: Device(config-cwmp)# end	Exits TR-069 Agent configuration mode and returns to privileged EXEC mode.

What to Do Next

Proceed to *Enabling the TR-069 Agent on the CPE* task.

Enabling the TR-069 Agent on the CPE**Before You Begin**

You must have set up the CPE as specified in the *Setting Up the CPE to Communicate with the ACS* task.

SUMMARY STEPS

1. **enable**
2. **configure terminal**
3. **cwmp agent**
4. **enable**
5. **end**

DETAILED STEPS

	Command or Action	Purpose
Step 1	enable Example: Device> enable	Enables privileged EXEC mode. <ul style="list-style-type: none"> • Enter your password if prompted.
Step 2	configure terminal Example: Device# configure terminal	Enters global configuration mode.
Step 3	cwmp agent Example: Device(config)# cwmp agent	Enables TR-069 Agent configuration mode.
Step 4	enable Example: Device(config-cwmp)# enable	Enables the CPE to initiate a TR-069 session with the ACS.
Step 5	end Example: Device(config-cwmp)# end	Exits TR-069 Agent configuration mode and returns to privileged EXEC mode.

Initiating a TR-069 Agent Session from the ACS

Before You Begin

You must have set up the CPE by using *Setting Up the CPE to Communicate with the ACS* task and enabled the TR-069 Agent on the CPE by using the *Enabling the TR-069 Agent on the CPE* task.

SUMMARY STEPS

1. **enable**
2. **configure terminal**
3. **cwmp agent**
4. **connection request username** *username*
5. **connection request username** [*encryption-type* | *cleartext-password*] *passwd*
6. **end**

DETAILED STEPS

	Command or Action	Purpose
Step 1	enable Example: Device> enable	Enables privileged EXEC mode. <ul style="list-style-type: none"> • Enter your password if prompted.
Step 2	configure terminal Example: Device# configure terminal	Enters global configuration mode.
Step 3	cwmp agent Example: Device(config)# cwmp agent	Enables TR-069 Agent configuration mode.
Step 4	connection request username <i>username</i> Example: Device(config-cwmp)# connection request username cisco	Specifies the username used to authenticate an ACS which makes a connection request to a CPE.
Step 5	connection request username [<i>encryption-type</i> <i>cleartext-password</i>] <i>passwd</i> Example: Device(config-cwmp)# connection request password 0 cisco	Specifies the password used to authenticate an ACS which makes a connection request to a CPE.

	Command or Action	Purpose
Step 6	end Example: Device(config-cwmp)# end	Exits TR-069 Agent configuration mode.

Configuring HTTP Digest Authentication Support

SUMMARY STEPS

1. enable
2. configure terminal
3. ip http digest algorithm *digest-algorithm*
4. end

DETAILED STEPS

	Command or Action	Purpose
Step 1	enable Example: Device> enable	Enables privileged EXEC mode. <ul style="list-style-type: none"> • Enter your password if prompted.
Step 2	configure terminal Example: Device# configure terminal	Enters global configuration mode.
Step 3	ip http digest algorithm <i>digest-algorithm</i> Example: Device(config)# ip http digest algorithm md5	Configures the MD5 digest algorithm parameter. <ul style="list-style-type: none"> • The choices for the digest algorithm parameter are MD5 and MD5-sess. • MD5 is the default.
Step 4	end Example: Device(config)# end	Exits global configuration mode.

Troubleshooting Tips

The following command can help troubleshoot the HTTP Digest Authentication Support:

- **show ip http client connection** --Displays all open client connections.

Clearing the HTTP Cookies

Perform this task to clear the HTTP cookies.

SUMMARY STEPS

1. **enable**
2. **clear ip http client cookie** [domain *cookie-domain* | name *cookie-name* | session *session-name*]

DETAILED STEPS

	Command or Action	Purpose
Step 1	enable Example: Device> enable	Enables privileged EXEC mode. • Enter your password if prompted.
Step 2	clear ip http client cookie [domain <i>cookie-domain</i> name <i>cookie-name</i> session <i>session-name</i>] Example: Device# clear ip http client cookie name test	Clears the HTTP cookies.

Troubleshooting Tips

The following command can help troubleshoot the HTTP cookies:

- **show ip http client cookie** --Displays the HTTP cookies.

Monitoring and Troubleshooting the HTTP Cookies

SUMMARY STEPS

1. **enable**
2. **show ip http client cookie {brief | summary} [domain *cookie-domain* | name *cookie-name* | session *session-name*]**
3. **debug ip http cookie**

DETAILED STEPS

	Command or Action	Purpose
Step 1	enable Example: Device> enable	Enables privileged EXEC mode. <ul style="list-style-type: none"> • Enter your password if prompted.
Step 2	show ip http client cookie {brief summary} [domain <i>cookie-domain</i> name <i>cookie-name</i> session <i>session-name</i>] Example: Device# show ip http client cookie brief name test	Shows the HTTP cookies.
Step 3	debug ip http cookie Example: Device# debug ip http cookie	Troubleshoots the HTTP cookies.

Configuration Examples for TR-069 Agent

Example: Setting Up the CPE to Communicate with the ACS

The following example shows how to set up the CPE to communicate with the ACS. The ACS URL is `http://172.25.117.78:7547/acs` and the password is `lab`.

```

!
configure terminal
cwp agent
management server url http://172.25.117.78:7547/acs
management server password 0 lab
provision code ABCD
exit
interface ethernet 0/0
  cwp wan

```

```

    cwmp wan default
    exit
  cwmp agent
    enable download
    session retry limit 12
    request outstanding 3
    parameter change notify interval 120
  !

```

Example: Configuring and Enabling CWMP using the Autoinstall feature

The following example shows how to configure CWMP using the autoinstall feature. Use the following set of commands in the network-config file or <hostname>-config file or router-config file in the TFTP server. No additional manual configuration is required for configuring CWMP on the device.

```

!
cwmp agent
  enable
  enable download
  management server password lab
  management server url http://10.1.98.229:7547/acs
  connection request username user1
  connection request password lab
!
ip http server
!

```

Additional References for TR-069 Agent

The following sections provide references related to the TR-069 Agent feature.

Related Documents

Related Topic	Document Title
TR-069 Agent commands: complete command syntax, command mode, command history, defaults, usage guidelines, and examples	<i>Cisco IOS Network Management Command Reference</i>
Cisco IOS commands	Cisco IOS Master Commands List, All Releases

Standards

Standard	Title
No new or modified standards are supported by this feature, and support for existing standards has not been modified by this feature.	--

MIBs

MIB	MIBs Link
None	To locate and download MIBs for selected platforms, Cisco IOS releases, and feature sets, use Cisco MIB Locator found at the following URL: http://www.cisco.com/go/mibs

RFCs

RFC	Title
No new or modified RFCs are supported by this feature, and support for existing RFCs has not been modified by this feature.	--

Technical Assistance

Description	Link
<p>The Cisco Support website provides extensive online resources, including documentation and tools for troubleshooting and resolving technical issues with Cisco products and technologies.</p> <p>To receive security and technical information about your products, you can subscribe to various services, such as the Product Alert Tool (accessed from Field Notices), the Cisco Technical Services Newsletter, and Really Simple Syndication (RSS) Feeds.</p> <p>Access to most tools on the Cisco Support website requires a Cisco.com user ID and password.</p>	http://www.cisco.com/cisco/web/support/index.html

Feature Information for TR-069 Agent

The following table provides release information about the feature or features described in this module. This table lists only the software release that introduced support for a given feature in a given software release train. Unless noted otherwise, subsequent releases of that software release train also support that feature.

Use Cisco Feature Navigator to find information about platform support and Cisco software image support. To access Cisco Feature Navigator, go to www.cisco.com/go/cfn. An account on Cisco.com is not required.

Table 42: Feature Information for TR-069 Agent

Feature Name	Releases	Feature Information
TR-069 Agent		<p>The TR-069 Agent feature manages a collection of CPEs, with the primary capability for auto-configuration and dynamic service provisioning, software image management, status and performance monitoring and diagnostics.</p> <p>The following commands were introduced or modified: cwmp agent, cwmp wan, cwmp wan default, debug cwmp, enable, enable download, management server password, management server url, parameter change notify interval, provision code, request outstanding, session retry limit, show cwmp map, show cwmp methods, show cwmp parameter, show cwmp persistent, show cwmp session.</p>
Addition of TR-111 Support	Cisco IOS XE Fuji 16.8.1	The Addition of TR-111 Support feature provides support for Device Association and Port Mapping in CWMP feature provides support for TR-111 enhancement.

Glossary

ACS--auto-configuration server.

CPE--customer premise equipment.



Broadband High Availability Stateful Switchover

The Cisco IOS XE Broadband High Availability Stateful Switchover feature provides the capability for dual Route Processor systems to support stateful switchover of Point-to-Point Protocol over X (PPPoX, where X designates a family of encapsulating communications protocols such as PPP over Ethernet [PPPoE], PPP over ATM [PPPoA], PPPoEoA, PPPoEoVLAN implementing PPP) sessions, thus allowing applications and features to maintain a stateful state while system control and routing protocol execution is transferred between an active and a standby processor.

- [Finding Feature Information, page 385](#)
- [Prerequisites for Broadband High Availability Stateful Switchover, page 386](#)
- [Restrictions for Broadband High Availability Stateful Switchover, page 386](#)
- [Information About Broadband High Availability Stateful Switchover, page 386](#)
- [How to Configure Broadband High Availability Stateful Switchover, page 389](#)
- [Configuration Examples for Broadband High Availability Stateful Switchover, page 396](#)
- [Additional References, page 400](#)
- [Feature Information for Broadband High Availability Stateful Switchover, page 401](#)

Finding Feature Information

Your software release may not support all the features documented in this module. For the latest caveats and feature information, see [Bug Search Tool](#) and the release notes for your platform and software release. To find information about the features documented in this module, and to see a list of the releases in which each feature is supported, see the feature information table.

Use Cisco Feature Navigator to find information about platform support and Cisco software image support. To access Cisco Feature Navigator, go to www.cisco.com/go/cfn. An account on Cisco.com is not required.

Prerequisites for Broadband High Availability Stateful Switchover

The stateful switchover (SSO) and nonstop forwarding (NSF) features must be enabled. For more information about SSO, see the "Stateful Switchover" module. For more information about NSF, see the "Configuring Nonstop Forwarding" module.

Restrictions for Broadband High Availability Stateful Switchover

SSO is supported only on High Availability (HA) network devices.

Information About Broadband High Availability Stateful Switchover

Feature Design of Broadband High Availability Stateful Switchover

Prior to the implementation of the Broadband High Availability Stateful Switchover feature, unplanned control plane and dataplane failures resulted in service outages and network downtime for PPPoX sessions. Cisco HA features, including SSO, enable network protection by providing fast recovery from such failures. The Broadband High Availability Stateful Switchover feature eliminates a source of outages by providing for stateful switchover to a standby processor while continuing to forward traffic. SSO protects from hardware or software faults on an active Route Processor (RP) by synchronizing protocol and state information for supported features with a standby RP, ensuring no interruption of sessions or connections if a switchover occurs.

The SSO feature takes advantage of RP redundancy by establishing one of the RPs as the active processor, designating the other RP as the standby processor, and then synchronizing critical state information between them. Following an initial (bulk) synchronization between the two processors, SSO dynamically maintains RP state information between them. A switchover from the active to the standby processor occurs when the active RP fails, when it is removed from the networking device, or when it is manually taken down for maintenance. The standby RP then takes control and becomes the active RP, preserving the sessions and connections for the supported features. At this time, packet forwarding continues while route convergence is completed on the newly active RP. A critical component of SSO and Cisco HA technology is the cluster control manager (CCM) that manages session re-creation on the standby processor. The Broadband High Availability Stateful Switchover feature allows you to configure subscriber redundancy policies that tune the synchronization process. For more information, see the [Configuring Subscriber Redundancy Policy for Broadband HA Stateful Switchover](#), on page 389.

The Broadband High Availability Stateful Switchover feature works with the Cisco NSF and SSO HA features, to maintain PPPoX sessions. NSF forwards network traffic and application state information so that user session information is maintained after a switchover.

For information about High Availability and stateful switchover, see the "High Availability Overview" chapter in the [Cisco ASR 1000 Series Aggregation Services Routers Software Configuration Guide](#).

Supported Broadband Aggregation Protocols

The Broadband High Availability Stateful Switchover feature set supports the broadband aggregation protocols described in the following sections:

SSO PPPoA

The Broadband High Availability Stateful Switchover feature delivers stateful switchover capability for PPP over ATM (PPPoA) sessions during Route Processor switchover.

SSO L2TP

The L2TP HA Session SSO/ISSU on a LAC/LNS feature provides a generic stateful switchover/In Service Software Upgrade (SSO/ISSU) mechanism for Layer 2 Tunneling Protocol (L2TP) on a Layer 2 Access Concentrator (LAC) and a Layer 2 Network Server (LNS). This feature preserves all fully established PPP and L2TP sessions during an SSO switchover or an ISSU upgrade or downgrade.

SSO PPPoE

The Broadband High Availability Stateful Switchover feature delivers stateful switchover capability for PPP over Ethernet (PPPoE) subscriber access sessions, including PPPoE, PPPoEoVLAN, and PPPoEoQinQ.

SSO RA-MLPS VPN

The Broadband High Availability Stateful Switchover feature delivers stateful switchover capability for PPPoX terminated into remote access (RA)-Multiprotocol Label Switching (MPLS) VPN or PPPoX into MPLS VPN sessions during processor switchover.

The figure below shows a typical broadband aggregation HA deployment with SSO functionality.

Figure 24: Broadband Aggregation High Availability Deployment

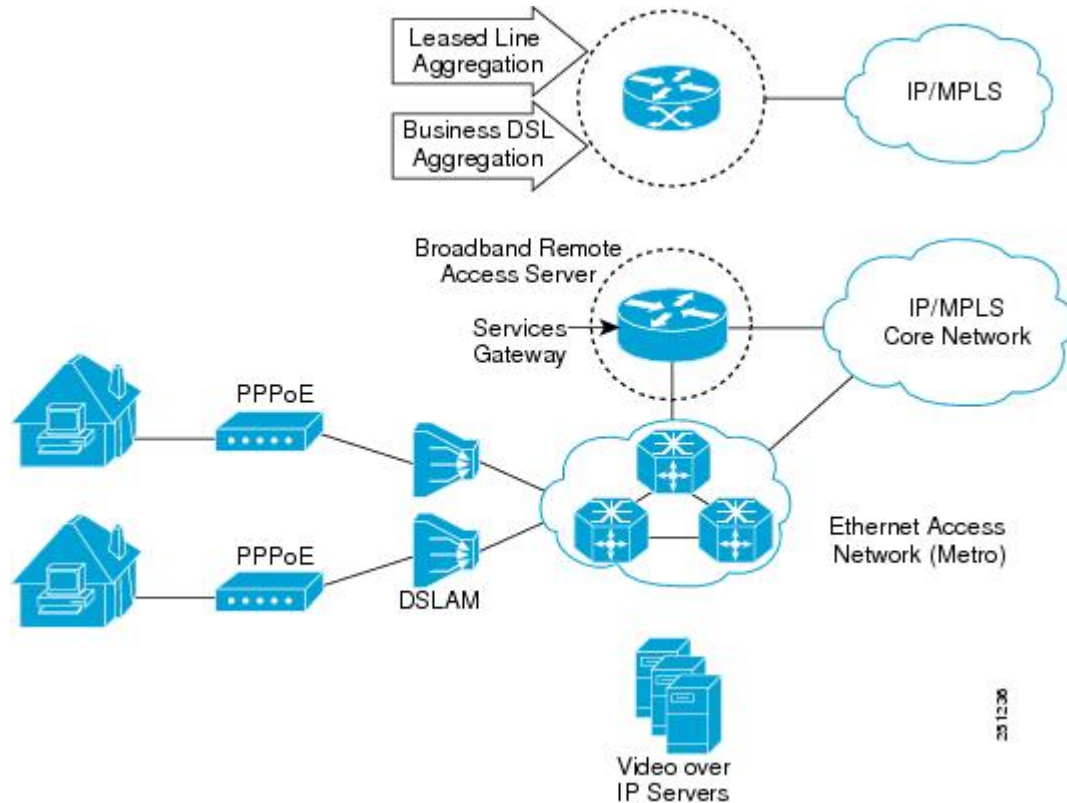

Benefits of Broadband High Availability Stateful Switchover

- Reduces operating costs associated with outages.
- Delivers higher service levels to subscribers.
- Improves network availability.
- Promotes continuous connectivity, lower packet loss, and consistent path flow through nodes providing specific network services.
- Mitigates service disruptions, reduces downtime costs, and increases operational efficiency.

How to Configure Broadband High Availability Stateful Switchover

Configuring Subscriber Redundancy Policy for Broadband HA Stateful Switchover

Perform this task to configure subscriber redundancy policy for HA SSO capability for broadband subscriber sessions.

SUMMARY STEPS

1. **enable**
2. **configure terminal**
3. **subscriber redundancy { bulk limit { cpu percent delay seconds [allow sessions] | time seconds } | dynamic limit cpu percent delay seconds [allow sessions] | delay seconds | rate sessions seconds }**
4. **exit**

DETAILED STEPS

	Command or Action	Purpose
Step 1	enable Example: Router> enable	Enables privileged EXEC mode. <ul style="list-style-type: none"> • Enter your password if prompted.
Step 2	configure terminal Example: Router# configure terminal	Enters global configuration mode.
Step 3	subscriber redundancy { bulk limit { cpu percent delay seconds [allow sessions] time seconds } dynamic limit cpu percent delay seconds [allow sessions] delay seconds rate sessions seconds } Example: Router(config)# subscriber redundancy bulk limit cpu 75 delay 20 allow 30	(Optional) Configures subscriber redundancy policy. <ul style="list-style-type: none"> • bulk --Configures bulk synchronization redundancy policy. • limit --Specifies the limit for the synchronization. • cpu percent --Specifies a CPU busy threshold value as a percentage. Range is from 0 to 100; default is 90. • delay seconds --Specifies the minimum amount of time, in seconds, that a session must be ready before bulk or dynamic synchronization occurs. Range is from 1 to 33550.

	Command or Action	Purpose
		<ul style="list-style-type: none"> • allow <i>sessions</i> --(Optional) Specifies the minimum number of sessions to synchronize once the CPU busy threshold is exceeded and the specified delay is met. Range is from 1 to 2147483637; default is 25. • dynamic --Configures a dynamic synchronization redundancy policy. • rate <i>sessions seconds</i> --Specifies the number of sessions per time period for bulk and dynamic synchronization. <ul style="list-style-type: none"> • <i>sessions</i>--Range is from 1 to 32000; default is 250. • <i>seconds</i>--Range in seconds is from 1 to 33550; default is 1.
Step 4	exit Example: Router(config)# exit	Exits global configuration mode and returns to privileged EXEC mode.

Verifying and Troubleshooting Subscriber Redundancy Policy for Broadband HA Stateful Switchover

To view the configuration, use the **show running-config** command. Sample output is available at [Configuration Examples for Broadband High Availability Stateful Switchover](#), on page 396.

SUMMARY STEPS

1. **show ccm clients**
2. **show ccm sessions**
3. **show ppp subscriber statistics**
4. **show pppatm statistics**
5. **show pppoe statistics**
6. **show vpdn redundancy**
7. **show vpdn history failure**
8. **show pppatm redundancy**
9. **show pppoe redundancy**
10. **debug pppatm redundancy**
11. **debug pppoe redundancy**

DETAILED STEPS

Step 1 show ccm clients

Example:

This command is useful for troubleshooting the CCM synchronization component. This command displays information about the CCM, which is the HA component that manages the capability to synchronize session launch on the standby processor of a redundant processor HA system.

Active Route Processor

Example:

```
Router# show ccm clients
CCM bundles sent since peer up:
Sent Queued for flow control
Sync Session 16000 0
Update Session 0 0
Active Bulk Sync End 1 0
Session Down 0 0
ISSU client msgs 346 0
Dynamic Session Sync 0 0
Unknown msgs 0 0
Client events sent since peer up:
PPP 144000
PPPoE 96002
VPDN FSP 0
AAA 64000
PPP SIP 0
LTERM 16000
AC 0
L2TP CC 0
SSS FM 16000
VPDN LNS 0
```

Standby Route Processor

Example:

```
Router# show ccm clients

CCM bundles rcvd since last boot:
Sync Session 16000
Update Session 0
Active Bulk Sync End 1
Session Down 0
ISSU client msgs 173
Dynamic Session Sync 0
Unknown msgs 0
Client events extracted since last boot:
PPP 144000
PPPoE 96002
VPDN FSP 0
AAA 64000
PPP SIP 0
LTERM 16000
AC 0
L2TP CC 0
SSS FM 16000
VPDN LNS 0
```

Step 2 show ccm sessions

This command is useful for troubleshooting the CCM synchronization component. This command shows information about sessions managed by CCM.

Active Route Processor

Example:

```
Router# show ccm sessions
Global CCM state: CCM HA Active - Dynamic Sync
Global ISSU state: Compatible, Clients Cap 0x9EFFF
Current Bulk Sent Bulk Rcvd
-----
Number of sessions in state Down: 0 0 0
Number of sessions in state Not Ready: 0 0 9279
Number of sessions in state Ready: 0 0 6721
Number of sessions in state Dyn Sync: 16000 16000 0
Timeout: Timer Type Delay Remaining Starts CPU Limit CPU Last
-----
Rate 00:00:01 - 64 - -
Dynamic CPU 00:00:10 - 0 90 0
Bulk Time Li 00:08:00 - 1 - -
RF Notif Ext 00:00:01 - 475 - -
```

Standby Route Processor

Example:

```
Router# show ccm sessions
Global CCM state: CCM HA Standby - Collecting
Global ISSU state: Compatible, Clients Cap 0x9EFFF
Current Bulk Sent Bulk Rcvd
-----
Number of sessions in state Down: 0 0 0
Number of sessions in state Not Ready: 0 0 8384
Number of sessions in state Ready: 16000 0 7616
Number of sessions in state Dyn Sync: 0 0 0
Timeout: Timer Type Delay Remaining Starts CPU Limit CPU Last
-----
Rate 00:00:01 - 0 - -
Dynamic CPU 00:00:10 - 0 90 0
Bulk Time Li 00:08:00 - 1 - -
RF Notif Ext 00:00:01 - 0 - -
```

Step 3 show ppp subscriber statistics

This command is useful for reviewing PPPoX session statistics. Use the **show ppp subscriber statistics** command to display a cumulative count of PPP subscriber events and statistics, and to display an incremental count since the **clear ppp subscriber statistics** command was last issued.

The following is sample output from the **show ppp subscriber statistics** command:

Example:

```
Router# show ppp subscriber statistics
PPP Subscriber Events      TOTAL      SINCE CLEARED
Encap                     5          5
DeEncap                   0          0
CstateUp                   7          7
CstateDown                 4          4
FastStart                  0          0
LocalTerm                  7          7
LocalTermVP                0          0
MoreKeys                   7          7
```

Forwarding	0	0
Forwarded	0	0
SSSDisc	0	0
SSMDisc	0	0
PPFDisc	0	0
PPPBindResp	7	7
PPPreneg	3	3
RestartTimeout	5	5
PPP Subscriber Statistics	TOTAL	SINCE CLEARED
IDB CSTATE UP	4	4
IDB CSTATE DOWN	8	8
APS UP	0	0
APS UP IGNORE	0	0
APS DOWN	0	0
READY FOR SYNC	8	8

Step 4 **show pppatm statistics**

This command is useful for obtaining statistics for PPPoA sessions. Use the **show pppatm statistics** command to display a total count of PPPoA events since the **clear pppatm statistics** command was last issued.

The following example displays PPPoA statistics:

Example:

```
Router# show pppatm statistics
 4000 : Context Allocated events
 3999 : SSS Request events
 7998 : SSS Msg events
 3999 : PPP Msg events
 3998 : Up Pending events
 3998 : Up Dequeued events
 3998 : Processing Up events
 3999 : Vaccess Up events
 3999 : AAA unique id allocated events
 3999 : No AAA method list set events
 3999 : AAA gets nas port details events
 3999 : AAA gets retrived attrs events
 68202 : AAA gets dynamic attrs events
 3999 : Access IE allocated events
```

Step 5 **show pppoe statistics**

This command is useful for reviewing PPPoX session statistics. Use the **show pppoe statistics** command to display a cumulative count of PPPoE events and statistics, and to display an incremental count since the **clear pppoe statistics** command was last issued.

The following is sample output from the **show pppoe statistics** command:

Example:

```
Router# show pppoe statistics
PPPoE Events          TOTAL          SINCE CLEARED
-----
INVALID              0              0
PRE-SERVICE FOUND    0              0
PRE-SERVICE NONE     0              0
SSS CONNECT LOCAL    0              0
SSS FORWARDING       0              0
SSS FORWARDED        0              0
SSS MORE KEYS        0              0
SSS DISCONNECT       0              0
CONFIG UPDATE        0              0
STATIC BIND RESPONSE 0              0
PPP FORWARDING       0              0
PPP FORWARDED        0              0
PPP DISCONNECT       0              0
```

PPP RENEGOTIATION	0	0
SSM PROVISIONED	0	0
SSM UPDATED	0	0
SSM DISCONNECT	0	0
PPPoE Statistics	TOTAL	SINCE CLEARED

SSS Request	0	0
SSS Response Stale	0	0
SSS Disconnect	0	0
PPPoE Handles Allocated	0	0
PPPoE Handles Freed	0	0
Dynamic Bind Request	0	0
Static Bind Request	0	0

Step 6 show vpdn redundancy

Use this command to verify the failure of any L2TP tunnels.

Example:

```
Router# show vpdn redundancy

L2TP HA support: Silent Failover
L2TP HA Status:
Checkpoint Messaging on: FALSE
Standby RP is up: TRUE
Recv'd Message Count: 0
L2TP Tunnels: 2/2/2/0 (total/HA-enabled/HA-est/resync)
L2TP Sessions: 10/10/10 (total/HA-enabled/HA-est)
L2TP Resynced Tunnels: 0/0 (success/fail)
```

Step 7 show vpdn history failure

Use this command to verify the failure of any VPDN groups.

Example:

```
Router# show vpdn history failure

% VPDN user failure table is empty
```

Step 8 show pppatm redundancy

Use the **show pppatm redundancy** command to display the PPPoA HA sessions summary. The following is sample output from the **show pppatm redundancy** command from a Cisco 10000 series router standby processor:

Example:

```
Router-stby# show pppatm redundancy
0 : Session recreate requests from CCM
0 : Session up events invoked
0 : Sessions reaching PTA
0 : Sessions closed by CCM
0 : Session down events invoked
0 : Queued sessions waiting for base hwidb creation
0 : Sessions queued for VC up notification so far
0 : Sessions queued for VC encaps change notification so far
0 : VC activation notifications received from ATM
0 : VC encaps change notifications received from ATM
0 : Total queued sessions waiting for VC notification(Encaps change+VC Activation)
```

Step 9 show pppoe redundancy

This command is useful for reviewing PPPoX session statistics. Use the **show pppoe redundancy** command to display statistics and events for PPPoE sessions. This command gives a cumulative count of PPPoE events and statistics, and an incremental count since the **clear pppoe redundancy** command was last issued.

The following is sample output from the **show pppoe redundancy** command from a Cisco 10000 series router standby processor:

Example:

```
Router-stby# show pppoe redundancy
12 Event Queues
size max kicks starts false suspends ticks(ms)
9 PPPoE CCM EV 0 1 2 3 1 0 20
Event Names
Events Queued MaxQueued Suspends usec/evt max/evt
1* 9 Recreate UP 2 0 1 0 1500 3000
2* 9 Recreate DOWN 0 0 0 0 0 0
3* 9 VC Wait UP 0 0 0 0 0 0
4* 9 VC Wait Encap 0 0 0 0 0 0
Sessions waiting for Base Vaccess: 0
Sessions waiting for ATM VC UP: 0
Sessions waiting for Auto VC Encap 0
```

Step 10

debug pppatm redundancy

Use the **debug pppatm redundancy** command to display CCM events and messages for PPPoA sessions on HA systems. This command is generally used only by Cisco engineers for internal debugging of CCM processes. The following is sample output from the **debug pppatm redundancy** command from a Cisco 10000 series router active processor:

Example:

```
Router# debug pppatm redundancy
PPP over ATM redundancy debugging is on
```

Step 11

debug pppoe redundancy

Use the **debug pppoe redundancy** command to display CCM events and messages for PPPoE sessions on HA systems. This command is generally used only by Cisco engineers for internal debugging of CCM processes.

Example:

```
Router# debug pppoe redundancy
Nov 22 17:21:11.327: PPPoE HA[0xBE000008] 9: Session ready to sync data
Nov 22 17:21:11.351: PPPoE HA[0xBE000008] 9: code = PADR, length = 58
Nov 22 17:21:11.351: PPPoE HA[0xBE000008] 9: code = SESSION ID, length = 2
Nov 22 17:21:11.351: PPPoE HA[0xBE000008] 9: code = SWITCH HDL, length = 4
Nov 22 17:21:11.351: PPPoE HA[0xBE000008] 9: code = SEGMENT HDL, length = 4
Nov 22 17:21:11.351: PPPoE HA[0xBE000008] 9: code = PHY SWIDB DESC, length = 20
Nov 22 17:21:11.351: PPPoE HA[0xBE000008] 9: code = VACCESS DESC, length = 28
Nov 22 17:21:11.351: PPPoE HA[0xBE000008] 9: Sync collection for ready events
Nov 22 17:21:11.351: PPPoE HA[0xBE000008] 9: code = PADR, length = 58
Nov 22 17:21:11.351: PPPoE HA[0xBE000008] 9: code = SESSION ID, length = 2
Nov 22 17:21:11.351: PPPoE HA[0xBE000008] 9: code = SWITCH HDL, length = 4
Nov 22 17:21:11.351: PPPoE HA[0xBE000008] 9: code = SEGMENT HDL, length = 4
Nov 22 17:21:11.351: PPPoE HA[0xBE000008] 9: code = PHY SWIDB DESC, length = 20
Nov 22 17:21:11.351: PPPoE HA[0xBE000008] 9: code = VACCESS DESC, length = 28
```

Configuration Examples for Broadband High Availability Stateful Switchover

Example Configuring Broadband High Availability Stateful Switchover

The following example shows how to configure the Broadband High Availability Stateful Switchover feature:

```
Router# configure terminal
Router(config)# subscriber redundancy bulk limit cpu 75 delay 20 allow 30
Router(config)# exit
```

The following is a sample configuration of PPPoX terminated into an RA-MPLS network with SSO. Commands that appear in the configuration task tables for this feature but that do not appear in the running configuration output are configured for their default settings.

```
Router# show running-config
hostname Router
!
boot-start-marker
boot system bootflash:packages.conf !
enable password cisco
!
aaa new-model
!
!
aaa authentication ppp default local
!
!
!
aaa session-id common
ppp hold-queue 80000
ip subnet-zero
no ip gratuitous-arps
no ip domain lookup
ip vrf vrf1
  rd 1:1
  route-target export 1:1
  route-target import 1:1
!
no ip dhcp use vrf connected
!
!
!
!
no subscriber policy recording rules
```

The following lines show the subscriber redundancy policy configuration:

```
subscriber redundancy dynamic limit cpu 90 delay 10
subscriber redundancy bulk limit cpu 90 delay 10
subscriber redundancy rate 4000 1
subscriber redundancy delay 10
no mpls traffic-eng
mpls ldp graceful-restart
mpls ldp router-id Loopback100
no virtual-template snmp
no issu config-sync policy bulk prc
no issu config-sync policy bulk bem
!
redundancy mode sso
username cisco password 0 cisco
!
bba-group pppoe grp1
```

```
    virtual-template 1
  !
  bba-group pppoe grp2
    virtual-template 2
  !
  bba-group pppoe grp3
    virtual-template 3
  !
  bba-group pppoe grp4
    virtual-template 4
  !
  bba-group pppoe grp5
    virtual-template 5
  !
  bba-group pppoe grp7
    virtual-template 7
  !
  bba-group pppoe grp8
    virtual-template 8
  !
  bba-group pppoe grp6
    virtual-template 6
  !
  !
interface Loopback0
  ip vrf forwarding vrf1
  ip address 10.1.1.1 255.255.255.255
  !
interface Loopback100
  ip address 192.168.0.1 255.255.255.255
  !
interface FastEthernet0/0/0
  ip address 192.168.2.26 255.255.255.0
  speed 100
  full-duplex
  !
interface GigabitEthernet1/0/0
  no ip address
  load-interval 30
  !
interface GigabitEthernet1/0/0.1
  encapsulation dot1Q 2
  pppoe enable group grp1
  !
  !
interface GigabitEthernet1/0/0.2
  encapsulation dot1Q 2
  pppoe enable group grp2
  !
  !
interface GigabitEthernet1/0/1
  no ip address
  !
interface GigabitEthernet1/0/1.1
  encapsulation dot1Q 2
  pppoe enable group grp3
  !
  !
interface GigabitEthernet1/0/1.2
  encapsulation dot1Q 2
  pppoe enable group grp4
  !
  !
interface GigabitEthernet1/0/2
  no ip address
  !
interface GigabitEthernet1/0/2.1
  encapsulation dot1Q 2
  pppoe enable group grp5
  !
  !
interface GigabitEthernet1/0/2.2
  encapsulation dot1Q 2
```

```

pppoe enable group grp6
!
!
interface GigabitEthernet1/0/3
no ip address
!
interface GigabitEthernet1/0/3.1
encapsulation dot1Q 2
pppoe enable group grp7
!
!
interface GigabitEthernet1/0/3.2
encapsulation dot1Q 2
pppoe enable group grp8
!
interface GigabitEthernet7/0/3
no ip address
!
interface GigabitEthernet8/0/0
mac-address 0011.0022.0033
ip vrf forwarding vrf1
ip address 10.1.1.2 255.255.255.0
negotiation auto
!
interface GigabitEthernet8/1/0
ip address 10.1.1.1 255.255.255.0
negotiation auto
mpls ip
!
interface Virtual-Template1
ip vrf forwarding vrf1
ip unnumbered Loopback0
no logging event link-status
peer default ip address pool pool1
no snmp trap link-status
keepalive 30
ppp authentication pap
!
interface Virtual-Template2
ip vrf forwarding vrf1
ip unnumbered Loopback0
no logging event link-status
peer default ip address pool pool2
no snmp trap link-status
keepalive 30
ppp authentication pap
!
interface Virtual-Template3
ip vrf forwarding vrf1
ip unnumbered Loopback0
no logging event link-status
peer default ip address pool pool3
no snmp trap link-status
keepalive 30
ppp authentication pap
!
interface Virtual-Template4
ip vrf forwarding vrf1
ip unnumbered Loopback0
no logging event link-status
peer default ip address pool pool4
no snmp trap link-status
keepalive 30
ppp authentication pap
!
interface Virtual-Template5
ip vrf forwarding vrf1
ip unnumbered Loopback0
no logging event link-status
peer default ip address pool pool5
no snmp trap link-status
keepalive 30
ppp authentication pap

```

```
!  
interface Virtual-Template6  
 ip vrf forwarding vrf1  
 ip unnumbered Loopback0  
 no logging event link-status  
 peer default ip address pool pool6  
 no snmp trap link-status  
 keepalive 30  
 ppp authentication pap  
!  
interface Virtual-Template7  
 ip vrf forwarding vrf1  
 ip unnumbered Loopback0  
 no logging event link-status  
 peer default ip address pool pool7  
 no snmp trap link-status  
 keepalive 30  
 ppp authentication pap  
!  
interface Virtual-Template8  
 ip vrf forwarding vrf1  
 ip unnumbered Loopback0  
 no logging event link-status  
 peer default ip address pool pool8  
 no snmp trap link-status  
 keepalive 30  
 ppp authentication pap  
!  
router ospf 1  
 log-adjacency-changes  
 nsf  
 network 10.1.1.0 0.0.0.255 area 0  
 network 224.0.0.0 0.0.0.255 area 0  
!  
router bgp 1  
 no synchronization  
 bgp log-neighbor-changes  
 bgp graceful-restart restart-time 120  
 bgp graceful-restart stalepath-time 360  
 bgp graceful-restart  
 neighbor 224.0.0.3 remote-as 1  
 neighbor 224.0.0.3 update-source Loopback100  
 no auto-summary  
!  
 address-family vpnv4  
 neighbor 224.0.0.3 activate  
 neighbor 224.0.0.3 send-community extended  
 exit-address-family  
!  
 address-family ipv4 vrf vrf1  
 redistribute connected  
 redistribute static  
 no auto-summary  
 no synchronization  
 exit-address-family  
!  
 ip local pool pool2 10.1.1.1 10.1.16.160  
 ip local pool pool3 10.13.1.1 10.13.16.160  
 ip local pool pool4 10.14.1.1 10.14.16.160  
 ip local pool pool5 10.15.1.1 10.15.16.160  
 ip local pool pool6 10.16.1.1 10.16.16.160  
 ip local pool pool7 10.17.1.1 10.17.16.160  
 ip local pool pool8 10.18.1.1 10.18.16.160  
 ip classless !  
!  
 no ip http server  
!  
!  
 arp 10.20.1.1 0020.0001.0001 ARPA  
 arp vrf vrf1 10.20.1.1 0020.0001.0001 ARPA !  
!  
!  
 line con 0
```

```

line aux 0
line vty 0 4
  password cisco
!
exception crashinfo file bootflash:crash.log !
end

```

Additional References

Related Documents

Related Topic	Document Title
Cisco IOS commands	Cisco IOS Master Command List, All Releases
Cisco IOS Broadband Access Aggregation and DSL commands	<i>Cisco IOS Broadband Access Aggregation and DSL Command Reference</i>
High Availability	"High Availability Overview" chapter in the Cisco ASR 1000 Series Aggregation Services Routers Software Configuration Guide
Performing an ISSU	The following chapters in the Cisco ASR 1000 Series Aggregation Services Routers Software Configuration Guide : <ul style="list-style-type: none"> • "Cisco IOS XE Software Package Compatibility for ISSU" • "In Service Software Upgrade (ISSU)"
Broadband ISSU	"Broadband High Availability In Service Software Upgrade" module
Stateful switchover	"Stateful Switchover" module
Configuring nonstop forwarding	"Configuring Nonstop Forwarding" module
Layer 2 Tunnel Protocol	Layer 2 Tunnel Protocol Technology Brief" module

Standards

Standard	Title
No new or modified standards are supported by this feature, and support for existing standards has not been modified by this feature.	--

MIBs

MIB	MIBs Link
None	To locate and download MIBs for selected platforms, Cisco software releases, and feature sets, use Cisco MIB Locator found at the following URL: http://www.cisco.com/go/mibs

RFCs

RFC	Title
No new or modified RFCs are supported by this feature, and support for existing RFCs has not been modified by this feature.	--

Technical Assistance

Description	Link
The Cisco Support and Documentation website provides online resources to download documentation, software, and tools. Use these resources to install and configure the software and to troubleshoot and resolve technical issues with Cisco products and technologies. Access to most tools on the Cisco Support and Documentation website requires a Cisco.com user ID and password.	http://www.cisco.com/cisco/web/support/index.html

Feature Information for Broadband High Availability Stateful Switchover

The following table provides release information about the feature or features described in this module. This table lists only the software release that introduced support for a given feature in a given software release train. Unless noted otherwise, subsequent releases of that software release train also support that feature.

Use Cisco Feature Navigator to find information about platform support and Cisco software image support. To access Cisco Feature Navigator, go to www.cisco.com/go/cfn. An account on Cisco.com is not required.

Table 43: Feature Information for the Broadband High Availability Stateful Switchover Feature

Feature Name	Releases	Feature Information
SSO--PPPoA	Cisco IOS XE Release 3.3S	<p>In Cisco IOS XE Release 3.3S, this feature was implemented on ASR 1000 Series Routers.</p> <p>The Broadband High Availability Stateful Switchover feature delivers stateful switchover capability for PPP over ATM (PPPoA) sessions during RP switchover.</p> <p>The following commands were introduced or modified: subscriber redundancy, debug pppatm redundancy, debug pppoe redundancy, show pppoe redundancy, show pppatm statistics.</p>
SSO--PPPoE	Cisco IOS XE Release 2.1 Cisco IOS XE Release 2.5	<p>In Cisco IOS XE Release 2.1, this feature was implemented on ASR 1000 Series Routers.</p> <p>This feature uses the SSO--PPPoE feature to provide the capability for dual Route Processor systems to support stateful switchover of PPPoX sessions and allow applications and features to maintain state while system control and routing protocol execution is transferred between an active and a standby processor.</p> <p>The following commands were introduced or modified: clear ppp subscriber statistics, clear pppoe statistics, debug pppoe redundancy, show ccm clients, show ccm sessions, show ppp subscriber statistics, show pppoe statistic, subscriber redundancy.</p>



Broadband High Availability In-Service Software Upgrade

The Broadband High Availability (HA) In-Service Software Upgrade (ISSU) feature ensures continuous operations of broadband access protocols during software upgrades, downgrades, and service enhancements.

- [Finding Feature Information](#), page 403
- [Prerequisites for Broadband High Availability In-Service Software Upgrade](#), page 404
- [Restrictions for Broadband High Availability In-Service Software Upgrade](#), page 404
- [Information About Broadband High Availability In-Service Software Upgrade](#), page 404
- [How to Configure Broadband High Availability In-Service Software Upgrade](#), page 407
- [Configuration Examples for Broadband High Availability In-Service Software Upgrade](#), page 413
- [Additional References](#), page 417
- [Feature Information for Broadband High Availability In-Service Software Upgrade](#), page 419

Finding Feature Information

Your software release may not support all the features documented in this module. For the latest caveats and feature information, see [Bug Search Tool](#) and the release notes for your platform and software release. To find information about the features documented in this module, and to see a list of the releases in which each feature is supported, see the feature information table.

Use Cisco Feature Navigator to find information about platform support and Cisco software image support. To access Cisco Feature Navigator, go to www.cisco.com/go/cfn. An account on Cisco.com is not required.

Prerequisites for Broadband High Availability In-Service Software Upgrade

The ISSU and nonstop forwarding (NSF) features must be enabled. For more information about In-Service Software Upgrade, see the "Performing an In Service Software Upgrade" module. For more information about NSF, see the "Configuring Nonstop Forwarding" module.

Restrictions for Broadband High Availability In-Service Software Upgrade

- You can perform an ISSU across a major Cisco IOS XE release.
- You can perform an ISSU from a Cisco IOS XE release that supports ISSU capability.

Information About Broadband High Availability In-Service Software Upgrade

Feature Design of Broadband High Availability In-Service Software Upgrade

Prior to the implementation of the Broadband High Availability In-Service Software Upgrade feature, software upgrades typically required planned outages that took the router or network out of service. The Broadband High Availability In-Service Software Upgrade feature enables the service provider to maximize network availability and eliminate planned outages by allowing the Cisco IOS XE release to be upgraded without taking the router or network out of service. ISSU is a procedure, based on Cisco high availability (HA) architecture, whereby the Cisco IOS XE infrastructure accomplishes an upgrade while packet forwarding continues and broadband sessions are maintained. Cisco HA architecture is based on redundant Route Processors and the NSF and SSO features, such that ports stay active and calls do not drop, eliminating network disruption during upgrades.

The ISSU feature allows deployment of new features, hardware, services, and maintenance fixes in a procedure that is seamless to end users. A critical component of ISSU and Cisco HA technology is the cluster control manager (CCM) that manages session recreation and synchronization on the standby processor. The Broadband High Availability In-Service Software Upgrade feature allows the configuration of subscriber redundancy policies that tune the synchronization process. For more information see the [Configuring Subscriber Redundancy Policy for Broadband High Availability In-Service Software Upgrade](#), on page 407.

The Broadband High Availability In-Service Software Upgrade feature handles upgrades and downgrades, and supports the following:

- Upgrades from one software feature release to another, as long as both versions support the ISSU feature, for example, from Cisco IOS XE Release 2.2 to Cisco IOS XE Release 2.3.
- Upgrades from one software maintenance release to another, for example from Cisco IOS XE Release 2.2.1 to Cisco IOS XE Release 2.2.2.

The Broadband High Availability In-Service Software Upgrade feature works with other Cisco IOS XE HA features, NSF and SSO, to maintain broadband sessions.

Performing an ISSU

For detailed information about HA and about performing an ISSU, see the following chapters in the [Cisco ASR 1000 Series Aggregation Services Routers Software Configuration Guide](#) :

- "High Availability Overview"
- "Cisco IOS XE Software Package Compatibility for ISSU"
- "In Service Software Upgrade (ISSU)"

Supported Broadband Aggregation Protocols

The Broadband High Availability In-Service Software Upgrade feature supports the following broadband aggregation protocols described in the following sections:

ISSU PPPoA

The Broadband High Availability In-Service Software Upgrade feature delivers ISSU capability for PPP over ATM (PPPoA) sessions during supported software upgrades, downgrades, and enhancements.

ISSU L2TP

The L2TP HA Session SSO/ISSU on a LAC/LNS feature provides a generic SSO/ISSU mechanism for Layer 2 Tunneling Protocol (L2TP) on a Layer 2 Access Concentrator (LAC) and a Layer 2 Network Server (LNS). This feature preserves all fully established PPP and L2TP sessions during an SSO switchover or an ISSU upgrade or downgrade.

ISSU PPPoE

The Broadband High Availability In-Service Software Upgrade feature delivers ISSU capability for PPP over Ethernet (PPPoE) subscriber access sessions, including PPPoE, PPPoE over VLAN, and PPPoE over QinQ sessions, during supported software upgrades, downgrades, and enhancements.

ISSU RA-MLPS VPN

The Broadband High Availability In-Service Software Upgrade feature delivers ISSU capability for PPPoA and PPPoE (PPPoX) sessions terminated into remote access (RA)-Multiprotocol Label Switching (MPLS) VPN or PPPoX into MPLS VPN during supported software upgrades, downgrades, and enhancements.

The figure below shows a typical broadband aggregation HA deployment with ISSU functionality.

Figure 25: Broadband Aggregation High Availability Deployment

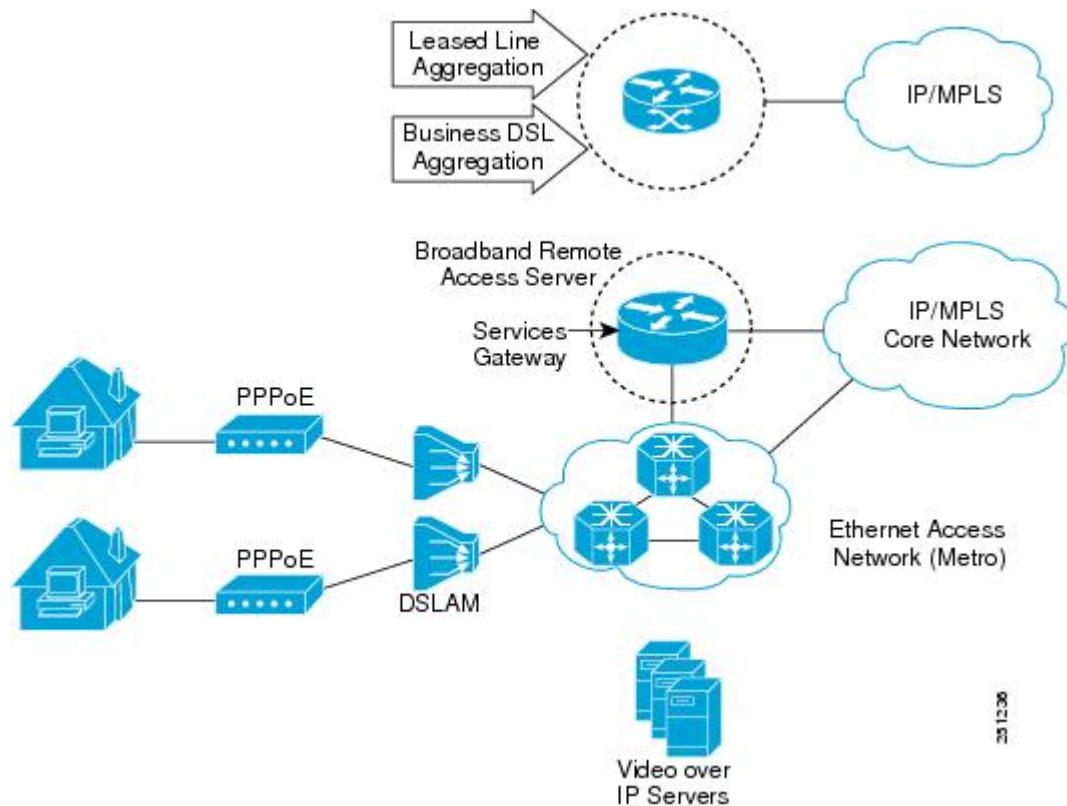

Benefits of Broadband High Availability In-Service Software Upgrade

- Eliminates network downtime for Cisco IOS XE software upgrades.
- Eliminates resource scheduling challenges associated with planned outages and late night maintenance windows.
- Accelerates deployment of new services and applications and allows faster implementation of new features, hardware, and fixes.
- Reduces operating costs due to outages while delivering higher service levels.
- Provides additional options for adjusting maintenance windows.
- Minimizes the impact of upgrades to service and allows for faster upgrades, resulting in higher availability.

How to Configure Broadband High Availability In-Service Software Upgrade

Configuring Subscriber Redundancy Policy for Broadband High Availability In-Service Software Upgrade

The Broadband High Availability In-Service Software Upgrade feature is enabled by default. This task configures subscriber redundancy policy for HA ISSU capability, allowing you to manage synchronization between HA active and standby processors.

SUMMARY STEPS

1. **enable**
2. **configure terminal**
3. **subscriber redundancy {bulk limit {cpu percentage delay *delay-time* [allow value] | time *seconds* | delay *delay-time* | dynamic limit cpu percentage delay *delay-time* [allow value] | rate sessions *time*}**
4. **exit**

DETAILED STEPS

	Command or Action	Purpose
Step 1	enable Example: Router> enable	Enables privileged EXEC mode. <ul style="list-style-type: none"> • Enter your password if prompted.
Step 2	configure terminal Example: Router# configure terminal	Enters global configuration mode.
Step 3	subscriber redundancy {bulk limit {cpu percentage delay <i>delay-time</i> [allow value] time <i>seconds</i> delay <i>delay-time</i> dynamic limit cpu percentage delay <i>delay-time</i> [allow value] rate sessions <i>time</i>} Example: Router(config)# subscriber redundancy bulk limit cpu 75 delay 20 allow 30	(Optional) Configures subscriber redundancy policy.

	Command or Action	Purpose
Step 4	exit Example: Router(config)# exit	Exits global configuration mode.

Verifying and Troubleshooting Subscriber Redundancy Policy for Broadband HA ISSU

To verify the subscriber redundancy policy configuration, use the **show running-config** command. Sample output is available in the [Configuration Examples for Broadband High Availability In-Service Software Upgrade](#), on page 413.

- Step 1, Step 2 and Step 3 are useful for troubleshooting the CCM synchronization component.
- Step 4, Step 5 and Step 6 are useful for reviewing PPPoX session statistics.
- Step 7 and Step 8 are useful for verifying the failure of any L2TP tunnels or VPDN groups.
- Step 9 and Step 10 are typically used by Cisco engineers for internal debugging purposes.

SUMMARY STEPS

1. **show ccm clients**
2. **show ccm sessions**
3. **show ccm queues**
4. **show ppp subscriber statistics**
5. **show pppatm statistics**
6. **show pppoe statistics**
7. **show vpdn redundancy**
8. **show vpdn history failure**
9. **debug pppatm redundancy**
10. **debug pppoe redundancy**

DETAILED STEPS

Step 1 **show ccm clients**

This command displays information about the CCM, the HA component that manages the capability to synchronize session launch on the standby processor of a redundant processor HA system. Use the **show ccm clients** command to display information about CCM clients.

Example:

```

Router# show ccm clients
CCM bundles sent since peer up:

      Sync Session          0          Queued for flow control
      Update Session        0          0
      Active Bulk Sync End  1          0
      Session Down          0          0
      ISSU client msgs     350         0
      Dynamic Session Sync  0          0
      Unknown msgs         0          0

Client events sent since peer up:
      PPP                   0
      PPPoE                 0
      VPDN FSP              0
      AAA                   0
      PPP SIP               0
      LTERM                 0
      AC                    0
      L2TP CC               0
      SSS FM                0
      IP SIP                0
      IP IF                 0
      COA                   0
      Auto Svc              0
      VPDN LNS              0

```

Step 2**show ccm sessions**

This command displays information about sessions managed by CCM.

Example:

```

Router# show ccm sessions

Global CCM state:          CCM HA Active - Dynamic Sync
Global ISSU state:        Compatible, Clients Cap 0x9EFFF
                          Current      Bulk Sent  Bulk Rcvd
-----
Number of sessions in state Down:    0          0          0
Number of sessions in state Not Ready: 0          0          0
Number of sessions in state Ready:   0          0          0
Number of sessions in state Dyn Sync: 0          0          0
Timeout: Timer Type   Delay   Remaining Starts   CPU Limit CPU Last
-----
Rate                  00:00:01 -    0          -          -
Dynamic CPU           00:00:10 -    0          90         0
Bulk CPU Lim          00:00:10 -    0          90         0
Bulk Time Li          00:00:01 -    0          -          -
RF Notif Ext          00:00:01 -    8          -          -

```

Step 3**show ccm queues**

Use the **show ccm queues** command to display queue statistics for CCM sessions on active and standby processors. This command is primarily used only by Cisco engineers for internal debugging of CCM processes.

Example:

```

Router# show ccm queues
11 Event Queues
      size  max    kicks    starts  false  suspends  ticks(ms)
3 CCM      0    8      82      83     1       0        20
Event Names
      Events  Queued  MaxQueued  Suspends  usec/evt  max/evt

```

1	3	Sync Session	0	0	0	0	0	0
2	3	Sync Client	0	0	0	0	0	0
3	3	Update	0	0	0	0	0	0
4	3	Session Down	0	0	0	0	0	0
5	3	Bulk Sync Begi	1	0	1	0	0	0
6	3	Bulk Sync Cont	2	0	2	0	0	0
7	3	Bulk Sync End	1	0	1	0	0	0
8	3	Rcv Bulk End	0	0	0	0	0	0
9	3	Dynamic Sync C	0	0	0	0	0	0
10	3	Going Active	0	0	0	0	0	0
11	3	Going Standby	0	0	0	0	0	0
12	3	Standby Presen	1	0	1	0	0	0
13	3	Standby Gone	0	0	0	0	0	0
15	3	CP Message	205	0	8	0	141	1000
16	3	Recr Session	0	0	0	0	0	0
17	3	Recr Update	0	0	0	0	0	0
18	3	Recr Sess Down	0	0	0	0	0	0
19	3	ISSU Session N	1	0	1	0	0	0
20	3	ISSU Peer Comm	0	0	0	0	0	0
21	3	Free Session	0	0	0	0	0	0
22	3	Sync Dyn Sessi	0	0	0	0	0	0
23	3	Recr Dyn Sessi	0	0	0	0	0	0
24	3	Session Ready	0	0	0	0	0	0
25	3	Pending Update	0	0	0	0	0	0
FSM Event Names			Events					
0		Invalid	0					
1		All Ready	0					
2		Required Not Re	0					
3		Update	0					
4		Down	0					
5		Error	0					
6		Ready	0					
7		Not Syncable	0					
8		Recreate Down	0					

Step 4 show ppp subscriber statistics

This command is useful for displaying events and statistics for PPP subscribers. Use the **show ppp subscriber statistics** command to display a cumulative count of PPP subscriber events and statistics, and to display an incremental count since the **clear ppp subscriber statistics** command was last issued.

Example:

```
Router# show ppp subscriber statistics
PPP Subscriber Events      TOTAL      SINCE CLEARED
Encap                     5          5
DeEncap                   0          0
CstateUp                  7          7
CstateDown                4          4
FastStart                 0          0
LocalTerm                 7          7
LocalTermVP               0          0
MoreKeys                  7          7
Forwarding                 0          0
Forwarded                 0          0
SSSDisc                   0          0
SSMDisc                   0          0
PPPDisc                   0          0
PPPBindResp               7          7
PPPreneg                  3          3
RestartTimeout            5          5
PPP Subscriber Statistics  TOTAL      SINCE CLEARED
IDB CSTATE UP             4          4
IDB CSTATE DOWN          8          8
APS UP                    0          0
APS UP IGNORE             0          0
```

```

APS DOWN                0                0
READY FOR SYNC          8                8

```

Step 5 **show pppatm statistics**

This command is useful for obtaining statistics for PPPoA sessions. Use the **show pppatm statistics** command to display a total count of PPPoA events since the **clear pppatm statistics** command was last issued.

Example:

```

Router# show pppatm statistics
4000 : Context Allocated events
3999 : SSS Request events
7998 : SSS Msg events
3999 : PPP Msg events
3998 : Up Pending events
3998 : Up Dequeued events
3998 : Processing Up events
3999 : Vaccess Up events
3999 : AAA unique id allocated events
3999 : No AAA method list set events
3999 : AAA gets nas port details events
3999 : AAA gets retrived attrs events
68202 : AAA gets dynamic attrs events
3999 : Access IE allocated events

```

Step 6 **show pppoe statistics**

This command is useful for obtaining statistics and events for PPPoE sessions. Use the **show pppoe statistics** command to display a cumulative count of PPPoE events and statistics, and to display an incremental count since the last time the **clear pppoe statistics** command was issued.

Example:

```

Router# show pppoe statistics
PPP Subscriber Events      TOTAL      SINCE CLEARED
Encap                     5          5
DeEncap                   2          2
CstateUp                  0          0
CstateDown                0          0
FastStart                 0          0
LocalTerm                 0          0
LocalTermVP               0          0
MoreKeys                  0          0
Forwarding                0          0
Forwarded                 0          0
SSSDisc                   0          0
SSMDisc                   0          0
PPPDisc                   0          0
PPPBindResp               0          0
PPPREneg                  0          0
RestartTimeout            2          2
PPP Subscriber Statistics  TOTAL      SINCE CLEARED
IDB CSTATE UP             0          0
IDB CSTATE DOWN           0          0
APS UP                     0          0
APS UP IGNORE             0          0
APS DOWN                   0          0
READY FOR SYNC            0          0
ASR1006-1#sh pppoe statis
ASR1006-1#sh pppoe statistics ?
| Output modifiers
|<cr>
ASR1006-1#sh pppoe statistics
PPPoE Events              TOTAL      SINCE CLEARED
-----
INVALID                    0          0

```

PRE-SERVICE FOUND	0	0
PRE-SERVICE NONE	0	0
SSS CONNECT LOCAL	0	0
SSS FORWARDING	0	0
SSS FORWARDED	0	0
SSS MORE KEYS	0	0
SSS DISCONNECT	0	0
SSS DISCONNECT ACK	0	0
CONFIG UPDATE	0	0
STATIC BIND RESPONSE	0	0
PPP FORWARDING	0	0
PPP FORWARDED	0	0
PPP DISCONNECT	0	0
PPP RENEGOTIATION	0	0
SSM PROVISIONED	0	0
SSM UPDATED	0	0
SSM ACCT STATS UPDATED	0	0
SSM DISCONNECT	0	0
	0	0
PPPoE Statistics	TOTAL	SINCE CLEARED
-----	-----	-----
SSS Request	0	0
SSS Response Stale	0	0
SSS Disconnect	0	0
PPPoE Handles Allocated	0	0
PPPoE Handles Freed	0	0
Dynamic Bind Request	0	0
Static Bind Request	0	0
SSM Async Stats Request	0	0

Step 7 show vpdn redundancy

Use this command to verify the failure of any L2TP tunnels.

Example:

```
Router# show vpdn redundancy

L2TP HA support: Silent Failover
L2TP HA Status:
  Checkpoint Messaging on: TRUE
  Standby RP is up:       TRUE
  Recv'd Message Count:   0
  L2TP Tunnels:           0/0/0/0 (total/HA-enabled/HA-est/resync)
  L2TP Sessions:          0/0/0 (total/HA-enabled/HA-est)
  L2TP Resynced Tunnels:  0/0 (success/fail)
```

Step 8 show vpdn history failure

Use this command to verify the failure of any VPDN groups.

Example:

```
Router# show vpdn history failure

% VPDN user failure table is empty
```

Step 9 debug pppatm redundancy

Use the **debug pppatm redundancy** command to display CCM events and messages for PPPoA sessions on HA systems. This command is generally used only by Cisco engineers for internal debugging of CCM processes.

Example:

```
Router# debug pppatm redundancy
*Dec 3 02:58:40.784: PPPATM HA: [14000001]: Received the first SHDB
```

```
*Dec 3 02:58:40.784: PPPoE HA: [14000001]: Base hwidb not created > yet, queuing SHDB *Dec 3
02:58:40.784: PPPoE HA: [14000001]:
Requesting base vaccess creation
```

Step 10 **debug pppoe redundancy**

Use the **debug pppoe redundancy** command to display CCM events and messages for PPPoE sessions on HA systems. This command is generally used only by Cisco engineers for internal debugging of CCM processes.

Example:

```
Router# debug pppoe redundancy
Nov 22 17:21:11.327: PPPoE HA[0xBE000008] 9: Session ready to sync data
Nov 22 17:21:11.351: PPPoE HA[0xBE000008] 9: code = PADR, length = 58
Nov 22 17:21:11.351: PPPoE HA[0xBE000008] 9: code = SESSION ID, length = 2
Nov 22 17:21:11.351: PPPoE HA[0xBE000008] 9: code = SWITCH HDL, length = 4
Nov 22 17:21:11.351: PPPoE HA[0xBE000008] 9: code = SEGMENT HDL, length = 4
Nov 22 17:21:11.351: PPPoE HA[0xBE000008] 9: code = PHY SWIDB DESC, length = 20
Nov 22 17:21:11.351: PPPoE HA[0xBE000008] 9: code = VACCESS DESC, length = 28
Nov 22 17:21:11.351: PPPoE HA[0xBE000008] 9: Sync collection for ready events
Nov 22 17:21:11.351: PPPoE HA[0xBE000008] 9: code = PADR, length = 58
Nov 22 17:21:11.351: PPPoE HA[0xBE000008] 9: code = SESSION ID, length = 2
Nov 22 17:21:11.351: PPPoE HA[0xBE000008] 9: code = SWITCH HDL, length = 4
Nov 22 17:21:11.351: PPPoE HA[0xBE000008] 9: code = SEGMENT HDL, length = 4
Nov 22 17:21:11.351: PPPoE HA[0xBE000008] 9: code = PHY SWIDB DESC, length = 20
Nov 22 17:21:11.351: PPPoE HA[0xBE000008] 9: code = VACCESS DESC, length = 28
```

Configuration Examples for Broadband High Availability In-Service Software Upgrade

Example Subscriber Redundancy Policy for Broadband High Availability In-Service Software Upgrade

The following example shows how to configure the Broadband High Availability In-Service Software Upgrade feature:

```
enable
configure terminal
subscriber redundancy bulk limit cpu 75 delay 20 allow 30
end
```

The following is a sample configuration of PPPoX terminated into an RA-MPLS network with SSO. Commands that appear in the configuration task tables for this feature but that do not appear in the running configuration output are configured for their default settings.

```
hostname Router
!
boot-start-marker
boot system bootflash:packages.conf !
enable password cisco
!
aaa new-model
!
!
```

```

aaa authentication ppp default local
!
!
!
aaa session-id common
ppp hold-queue 80000
ip subnet-zero
no ip gratuitous-arps
no ip domain lookup
ip vrf vrfl
    rd 1:1
    route-target export 1:1
    route-target import 1:1
!
no ip dhcp use vrf connected
!
!
!
no subscriber policy recording rules

```

The following lines show subscriber redundancy policy configuration:

```

subscriber redundancy dynamic limit cpu 90 delay 10
subscriber redundancy bulk limit cpu 90 delay 10
subscriber redundancy rate 4000 1
subscriber redundancy delay 10
no mpls traffic-eng
mpls ldp graceful-restart
mpls ldp router-id Loopback100
no virtual-template snmp
no issu config-sync policy bulk prc
no issu config-sync policy bulk bem
!
redundancy mode sso
username cisco password 0 cisco
!
buffers small permanent 15000
buffers middle permanent 12000
buffers large permanent 1000
bba-group pppoe grp1
    virtual-template 1
!
bba-group pppoe grp2
    virtual-template 2
!
bba-group pppoe grp3
    virtual-template 3
!
bba-group pppoe grp4
    virtual-template 4
!
bba-group pppoe grp5
    virtual-template 5
!
bba-group pppoe grp7
    virtual-template 7
!
bba-group pppoe grp8
    virtual-template 8
!
bba-group pppoe grp6
    virtual-template 6
!
!
interface Loopback0
    ip vrf forwarding vrfl
    ip address 172.16.1.1 255.255.255.255
!
interface Loopback100
    ip address 172.31.0.1 255.255.255.255
!
interface FastEthernet0/0/0

```

```
    ip address 192.168.2.26 255.255.255.0
    speed 100
    full-duplex
!
interface GigabitEthernet1/0/0
no ip address
load-interval 30
!
interface GigabitEthernet1/0/0.1
encapsulation dot1Q 2
pppoe enable group grp1
!
!
interface GigabitEthernet1/0/0.2
encapsulation dot1Q 2
pppoe enable group grp2
!
!
interface GigabitEthernet1/0/1
no ip address
!
interface GigabitEthernet1/0/1.1
encapsulation dot1Q 2
pppoe enable group grp3
!
!
interface GigabitEthernet1/0/1.2
encapsulation dot1Q 2
pppoe enable group grp4
!
!
interface GigabitEthernet1/0/2
no ip address
!
interface GigabitEthernet1/0/2.1
encapsulation dot1Q 2
pppoe enable group grp5
!
!
interface GigabitEthernet1/0/2.2
encapsulation dot1Q 2
pppoe enable group grp6
!
!
interface GigabitEthernet1/0/3
no ip address
!
interface GigabitEthernet1/0/3.1
encapsulation dot1Q 2
pppoe enable group grp7
!
!
interface GigabitEthernet1/0/3.2
encapsulation dot1Q 2
pppoe enable group grp8
!
interface GigabitEthernet7/0/3
no ip address
!
interface GigabitEthernet8/0/0
mac-address 0011.0022.0033
ip vrf forwarding vrf1
ip address 10.1.1.2 255.255.255.0
negotiation auto
!
interface GigabitEthernet8/1/0
ip address 10.1.1.1 255.255.255.0
negotiation auto
mpls ip
!
interface Virtual-Template1
ip vrf forwarding vrf1
ip unnumbered Loopback0
```

```
no logging event link-status
peer default ip address pool pool1
no snmp trap link-status
keepalive 30
ppp authentication pap
!
interface Virtual-Template2
ip vrf forwarding vrf1
ip unnumbered Loopback0
no logging event link-status
peer default ip address pool pool2
no snmp trap link-status
keepalive 30
ppp authentication pap
!
interface Virtual-Template3
ip vrf forwarding vrf1
ip unnumbered Loopback0
no logging event link-status
peer default ip address pool pool3
no snmp trap link-status
keepalive 30
ppp authentication pap
!
interface Virtual-Template4
ip vrf forwarding vrf1
ip unnumbered Loopback0
no logging event link-status
peer default ip address pool pool4
no snmp trap link-status
keepalive 30
ppp authentication pap
!
interface Virtual-Template5
ip vrf forwarding vrf1
ip unnumbered Loopback0
no logging event link-status
peer default ip address pool pool5
no snmp trap link-status
keepalive 30
ppp authentication pap
!
interface Virtual-Template6
ip vrf forwarding vrf1
ip unnumbered Loopback0
no logging event link-status
peer default ip address pool pool6
no snmp trap link-status
keepalive 30
ppp authentication pap
!
interface Virtual-Template7
ip vrf forwarding vrf1
ip unnumbered Loopback0
no logging event link-status
peer default ip address pool pool7
no snmp trap link-status
keepalive 30
ppp authentication pap
!
interface Virtual-Template8
ip vrf forwarding vrf1
ip unnumbered Loopback0
no logging event link-status
peer default ip address pool pool8
no snmp trap link-status
keepalive 30
ppp authentication pap
!
router ospf 1
log-adjacency-changes
nsf
network 10.1.1.0 0.0.0.255 area 0
```



```

    network 10.0.0.0 0.0.0.255 area 0
!
router bgp 1
  no synchronization
  bgp log-neighbor-changes
  bgp graceful-restart restart-time 120
  bgp graceful-restart stalepath-time 360
  bgp graceful-restart
  neighbor 10.0.0.3 remote-as 1
  neighbor 10.0.0.3 update-source Loopback100
  no auto-summary
  !
  address-family vpv4
  neighbor 10.0.0.3 activate
  neighbor 10.0.0.3 send-community extended
  exit-address-family
  !
  address-family ipv4 vrf vrf1
  redistribute connected
  redistribute static
  no auto-summary
  no synchronization
  exit-address-family
!
ip local pool pool2 10.1.1.1 10.1.16.160
ip local pool pool3 10.1.1.1 10.1.16.160
ip local pool pool4 10.1.1.1 10.1.16.160
ip local pool pool5 10.1.1.1 10.1.16.160
ip local pool pool6 10.1.1.1 10.1.16.160
ip local pool pool7 10.1.1.1 10.1.16.160
ip local pool pool8 10.1.1.1 10.1.16.160
ip classless !
!
no ip http server
!
!
arp 10.1.1.1 0020.0001.0001 ARPA
arp vrf vrf1 10.1.1.1 0020.0001.0001 ARPA !
!
!
line con 0
line aux 0
line vty 0 4
  password cisco
!
exception crashinfo file bootflash:crash.log !
end

```

Additional References

Related Documents

Related Topic	Document Title
Cisco IOS commands	Cisco IOS Master Commands List, All Releases
Cisco IOS Broadband commands	Cisco IOS Broadband Access Aggregation and DSL Command Reference
High Availability	"High Availability Overview" chapter in the Cisco ASR 1000 Series Aggregation Services Routers Software Configuration Guide

Related Topic	Document Title
Performing an ISSU	The following chapters in the Cisco ASR 1000 Series Aggregation Services Routers Software Configuration Guide : <ul style="list-style-type: none"> "Cisco IOS XE Software Package Compatibility for ISSU" "In Service Software Upgrade (ISSU)"
Broadband SSO	Broadband High Availability Stateful Switchover
Stateful switchover	Stateful Switchover
Cisco nonstop forwarding	Cisco Nonstop Forwarding
Layer 2 Tunnel Protocol	Layer 2 Tunnel Protocol Technology Brief
Additional information about commands used in this document	<ul style="list-style-type: none"> <i>Cisco IOS Broadband Access Aggregation and DSL Command Reference</i> Cisco IOS Master Command List, All Releases

Standards

Standard	Title
No new or modified standards are supported by this feature, and support for existing RFCs has not been modified by this feature.	--

MIBs

MIB	MIBs Link
No new or modified MIBs are supported by this feature, and support for existing MIBs has not been modified by this feature.	To locate and download MIBs for selected platforms, Cisco IOS software releases, and feature sets, use Cisco MIB Locator found at the following URL: http://www.cisco.com/go/mibs

RFCs

RFC	Title
No new or modified RFCs are supported by this feature, and support for existing RFCs has not been modified by this feature.	--

Technical Assistance

Description	Link
The Cisco Support and Documentation website provides online resources to download documentation, software, and tools. Use these resources to install and configure the software and to troubleshoot and resolve technical issues with Cisco products and technologies. Access to most tools on the Cisco Support and Documentation website requires a Cisco.com user ID and password.	http://www.cisco.com/cisco/web/support/index.html

Feature Information for Broadband High Availability In-Service Software Upgrade

The following table provides release information about the feature or features described in this module. This table lists only the software release that introduced support for a given feature in a given software release train. Unless noted otherwise, subsequent releases of that software release train also support that feature.

Use Cisco Feature Navigator to find information about platform support and Cisco software image support. To access Cisco Feature Navigator, go to www.cisco.com/go/cfn. An account on Cisco.com is not required.

Table 44: Feature Information for Cisco IOS Broadband High Availability In-Service Software Upgrade

Feature Name	Releases	Feature Information
ISSU-PPPoA	Cisco IOS XE Release 3.3S	<p>This feature was introduced on Cisco ASR 1000 Series Routers.</p> <p>This feature uses the ISSU support for PPPoA to ensure continuous operations of broadband access protocols during software upgrades.</p> <p>The following commands were introduced or modified:</p> <p>debug pppatm redundancy , debug pppoe redundancy, show pppoe redundancy, show pppatm redundancy, show pppatm statistics, subscriber redundancy</p>
ISSU--PPPoE	Cisco IOS XE Release 2.1 Cisco IOS XE Release 2.5	<p>This feature was introduced on Cisco ASR 1000 Series Routers.</p> <p>This feature uses the ISSU--PPPoE support to ensure continuous operations of broadband access protocols during software upgrades, downgrades, and service enhancements.</p> <p>The following commands were introduced or modified: clear ppp subscriber statistics, clear pppoe statistics, debug pppoe redundancy, show ccm clients, show ccm sessions, show ppp subscriber statistics, show pppoe statistic, subscriber redundancy</p>



Controlling Subscriber Bandwidth

The Dynamic Subscriber Bandwidth Selection (DBS) feature enables wholesale service providers to sell different classes of service to retail service providers by controlling bandwidth at the ATM virtual circuit (VC) level. ATM quality of service (QoS) parameters from the subscriber domain are applied to the ATM PVC on which a PPP over Ethernet (PPPoE) or PPP over ATM (PPPoA) session is established.

- [Finding Feature Information, page 421](#)
- [Prerequisites for Controlling Subscriber Bandwidth, page 421](#)
- [Restrictions for Controlling Subscriber Bandwidth, page 422](#)
- [Information About Controlling Subscriber Bandwidth, page 422](#)
- [How to Control Subscriber Bandwidth, page 423](#)
- [Configuration Examples for Controlling Subscriber Bandwidth, page 433](#)
- [Additional References, page 434](#)
- [Feature Information for Controlling Subscriber Bandwidth, page 436](#)

Finding Feature Information

Your software release may not support all the features documented in this module. For the latest caveats and feature information, see [Bug Search Tool](#) and the release notes for your platform and software release. To find information about the features documented in this module, and to see a list of the releases in which each feature is supported, see the feature information table.

Use Cisco Feature Navigator to find information about platform support and Cisco software image support. To access Cisco Feature Navigator, go to www.cisco.com/go/cfn. An account on Cisco.com is not required.

Prerequisites for Controlling Subscriber Bandwidth

A Cisco ASR 1000 series router must have the following shared port adapters (SPAs) installed to enable DBS:

- SPA-3XOC3-ATM-V2
- SPA-1XOC3-ATM-V2

- SPA-1XOC12-ATM-V2

Restrictions for Controlling Subscriber Bandwidth

The DBS feature does not support the following:

- Switched virtual circuits (SVC)
- ATM port adapters installed in a Cisco ASR 1000 series router
- When changing QoS values dynamically on a VC, there can be some duration (in milliseconds) during which traffic on the VC is dropped.

Information About Controlling Subscriber Bandwidth

Traffic-Shaping Parameters

Using DBS you can set the ATM permanent virtual circuit (PVC) traffic-shaping parameters to be dynamically changed based on the RADIUS profile of a PPPoE or PPPoA user logging in on the PVC. If the user is the first user on a given PVC, the RADIUS profile values override the default values of the PVC. If users already exist on the PVC, the new value overrides the existing configuration only if it is higher than the existing value. If multiple PPPoE sessions are allowed on a subscriber VC, the highest peak cell rate (PCR) and sustainable cell rate (SCR) of all the sessions are selected as the PCR and SCR, respectively, of the VC.

You can apply DBS QoS parameters per user as well as per domain. If you apply DBS QoS parameters under a domain profile, all users in that profile are assigned the same DBS QoS parameters. These parameters are assigned to the RADIUS profile for that domain. You can also apply distinctive DBS QoS parameters via the RADIUS user profile.

Traffic-shaping parameters can be locally configured by Cisco IOS command-line interface (CLI) in VC-mode, VC-class, range mode, or PVC-in-range mode. These parameters have a lower priority and are overridden by the shaping parameters specified in the domain service profile. Traffic-shaping parameters that are CLI-configured at the VC class interface or subinterface level are treated as the default QoS parameters for the PVCs to which they apply. These parameters are overridden by the domain service profile QoS parameters of the domain the user is logged in to. If no VC class is configured, the default is the unspecified bit rate (UBR).

When a network access server (NAS) sends a domain authorization request and receives an affirmative response from the RADIUS server, this response may include a "QoS-management" string via vendor-specific attribute (VSA) 26 for QoS management in the NAS. The QoS management values are configured as part of the domain service profile attributes on the RADIUS server. These values contain PCR and SCR values for a particular user or domain. If the QoS specified for a domain or user cannot be applied on the PVC to which the session belongs, the session is not established.

Changing PVC traffic parameters because of new simultaneous PPPoE sessions on the PVC does not cause existing PPPoE sessions that are already established to disconnect. Changing domain service profile QoS parameters on the RADIUS server does not cause traffic parameters to automatically change for PVCs that have existing sessions.

When you enter the **dbns enable** or **no dbns enable** command to configure or unconfigure DBS, existing sessions are not disconnected. If you have a session that has been configured for DBS and you configure the **no dbns enable** command on a VC, additional sessions that are configured will display DBS-configured QoS values until the first new session is up. After the first session is brought up, the VC has default and locally configured values. If you configure the **dbns enable** command after multiple sessions are already up on the VC, all sessions on that VC have DBS QoS parameters.

Benefits of Controlling Subscriber Bandwidth

DBS provides the following benefits:

- Wholesale service providers can provide different bandwidth options to their retail service provider customers, such as ISPs and enterprises.
- Subscribers can choose between enhanced and basic service, with a fixed billing plan for each service.

How to Control Subscriber Bandwidth

Configuring DBS Under a VC Class

Perform the following task to configure DBS under a VC class.

SUMMARY STEPS

1. **enable**
2. **configure terminal**
3. **vc-class atm** *vc-class-name*
4. **dbns enable**

DETAILED STEPS

	Command or Action	Purpose
Step 1	enable Example: Router> enable	Enables privileged EXEC mode. <ul style="list-style-type: none"> • Enter your password if prompted.
Step 2	configure terminal Example: Router# configure terminal	Enters global configuration mode.

	Command or Action	Purpose
Step 3	vc-class atm <i>vc-class-name</i> Example: Router(config)# vc-class atm class1	Creates an ATM VC class and enters ATM VC class configuration mode. <ul style="list-style-type: none"> • A VC class can be applied to an ATM interface, subinterface, or VC.
Step 4	dbns enable Example: Router(config-vc-class)# dbns enable	Applies DBS QoS parameters.

Configuring DBS on a PVC

Perform the following task to configure DBS for a PVC.

SUMMARY STEPS

1. **enable**
2. **configure terminal**
3. **interface atm** *number* [**point-to-point** | **multipoint**]
4. **pvc** [*name*] *vpi* *lvc*
5. **dbns enable**
6. **protocol pppoe**

DETAILED STEPS

	Command or Action	Purpose
Step 1	enable Example: Router> enable	Enables privileged EXEC mode. <ul style="list-style-type: none"> • Enter your password if prompted.
Step 2	configure terminal Example: Router# configure terminal	Enters global configuration mode.

	Command or Action	Purpose
Step 3	interface atm <i>number</i> [point-to-point multipoint] Example: <pre>Router(config)# interface atm 5/0.1 multipoint</pre>	Specifies an ATM interface or subinterface and enters interface configuration mode.
Step 4	pvc [<i>name</i>] <i>vpi</i> / <i>vci</i> Example: <pre>Router(config-if)# pvc 2/101</pre>	Specifies an ATM PVC and creates or assigns a name to an ATM PVC, and enters interface-ATM-VC configuration mode. Note The arguments <i>vpi</i> and <i>vci</i> cannot both be set to 0; if one is 0, the other cannot be 0.
Step 5	dbns enable Example: <pre>Router(config-if-atm-vc)# dbns enable</pre>	Applies DBS QoS parameters.
Step 6	protocol pppoe Example: <pre>Router(config-if-atm-vc)# protocol pppoe</pre>	Specifies PPPoE as the protocol of the ATM PVC.

Configuring DBS on a Range of PVCs

Perform this task to configure DBS for a range of PVCs.

SUMMARY STEPS

1. **enable**
2. **configure terminal**
3. **interface atm** *number* [**point-to-point** | **multipoint**]
4. **range**[*range-name*] **pvc** *start-vpi* / *start-vci* *end-vpi* / *end-vci*
5. **dbns enable**

DETAILED STEPS

	Command or Action	Purpose
Step 1	enable	Enables privileged EXEC mode.

	Command or Action	Purpose
	Example: Router> enable	<ul style="list-style-type: none"> Enter your password if prompted.
Step 2	configure terminal Example: Router# configure terminal	Enters global configuration mode.
Step 3	interface atm <i>number</i> [point-to-point multipoint] Example: Router(config)# interface atm 5/0.1 multipoint	Specifies an ATM interface or subinterface and enters interface configuration mode.
Step 4	range[<i>range-name</i>] pvc <i>start-vpi</i> / <i>start-vci</i> <i>end-vpi</i> / <i>end-vci</i> Example: Router(config-subif)# range pvc 0/101 0/500 class-range pppoe	Defines a range of ATM PVCs and enables PVC range configuration mode.
Step 5	dbns enable Example: Router(config-if-atm-vc)# dbns enable	Applies DBS QoS parameters.

Configuring DBS on a PVC Within a PVC Range

Perform this task to configure DBS for a specific PVC within a range of PVCs.

SUMMARY STEPS

- enable
- configure terminal
- interface atm *number* [point-to-point | multipoint]
- range [*range-name*] pvc *start-vpi* / *start-vci* *end-vpi* / *end-vci*
- in-range [*pvc-name*] [[*vpi* /]*vci*]
- dbns enable

DETAILED STEPS

	Command or Action	Purpose
Step 1	enable Example: Router> enable	Enables privileged EXEC mode. <ul style="list-style-type: none"> • Enter your password if prompted.
Step 2	configure terminal Example: Router# configure terminal	Enters global configuration mode.
Step 3	interface atm number [point-to-point multipoint] Example: Router(config)# interface atm 5/0.1 multipoint	Specifies an ATM interface or subinterface and enters interface configuration mode.
Step 4	range [range-name] pvc start-vpi / start-vci end-vpi / end-vci Example: Router(config-subif)# range pvc 0/101 0/500 class-range pppoe	Defines a range of ATM PVCs and enables PVC range configuration mode.
Step 5	in-range [pvc-name] [[vpi /]vci] Example: Router(config-if-atm-range)# pvc-in-range pvc1 3/104	Defines an individual PVC within a PVC range and enables PVC-in-range configuration mode.
Step 6	dbns enable Example: Router(config-if-atm-range-pvc)# dbns enable	Applies DBS QoS parameters.

Configuring the RADIUS Attributes for DBS

You can apply DBS QoS parameters per user as well as per domain. If you apply DBS QoS parameters under a domain profile, all users in that profile are assigned the same DBS QoS parameters. These parameters are assigned to the RADIUS profile for that domain. You can also apply distinctive DBS QoS parameters via the RADIUS user profile.

Configure the RADIUS attributes listed in this section in the user or domain profiles on the authentication, authorization, and accounting (AAA) server. The user or domain profile is downloaded from the AAA server as part of user authentication.

The QoS management string for DBS has the following syntax:

```
Cisco-Avpair = atm:peak-cell-rate=155000
Cisco-Avpair = atm:sustainable-cell-rate=155000
```

You must configure the PCR. Configuring the SCR is optional. If you configure only the PCR, the ATM service type is an unspecified bit rate (UBR). If you specify both the SCR and the PCR, the ATM service type is a variable bit rate nonreal-time (VBR-nrt) connection.

If the peak rate is greater than the maximum rate permitted on the ATM physical interface, the PCR applied on the ATM PVC is set to the maximum rate. If the specified PCR is less than the minimum rate, then the PCR applied on the ATM PVC is the minimum rate.

If the sustainable-cell-rate (in Kbps) applied exceeds the maximum for the interface, the session is rejected.

**Note**

DBS cannot change service categories such as from UBR to VBR-nrt. For details, see the table in [Configuring Dynamic Subscriber Services](#).

Verifying DBS

**Note**

The configuration examples in this section explain the PPPOE termination using a VPDN group.

SUMMARY STEPS

1. Enter the **show atm pvc *vpi / vci*** command to view details about ATM PVCs or VCs:
2. Enter the **show atm pvc db**s command to display information about ATM PVCs that have DBS QoS parameters applied:
3. Enter the **show running-config** command to verify that DBS QoS parameters have been applied. If you enter the **db**s enable or the **no db**s enable command, it appears in the output of the **show running-config** command. If you enter the **default db**s enable command, it does not appear.

DETAILED STEPS

Step 1 Enter the **show atm pvc *vpi / vci*** command to view details about ATM PVCs or VCs:

Example:

```
Router# show atm pvc 0/75
ATM1/0.4:VCD:1, VPI:0, VCI:75
UBR, PeakRate:149760
AAL5-LLC/SNAP, etype:0x0, Flags:0xC20, VCmode:0x0
OAM frequency:0 second(s), OAM retry frequency:1 second(s)
OAM up retry count:3, OAM down retry count:5
OAM Loopback status:OAM Disabled
OAM VC state:Not Managed
```

```

ILMI VC state:Not Managed
PA TxRingLimit:40 particles
PA Rx Limit:1600 particles
InARP frequency:15 minutes(s)
Transmit priority 4
InPkts:18, OutPkts:21, InBytes:1263, OutBytes:1476
InProc:18, OutProc:3
InFast:0, OutFast:0, InAS:0, OutAS:0
InPktDrops:0, OutPktDrops:0/0/0 (holdq/outputq/total)
CrcErrors:0, SarTimeOuts:0, OverSizedSDUs:0, LengthViolation:0,
CPIErrors:0
Out CLP=1 Pkts:0
OAM cells received:0
F5 InEndloop:0, F5 InSegloop:0, F5 InAIS:0, F5 InRDI:0
F4 InEndloop:0, F4 InSegloop:0, F4 InAIS:0, F4 InRDI:0
OAM cells sent:0
F5 OutEndloop:0, F5 OutSegloop:0, F5 OutRDI:0
F4 OutEndloop:0, F4 OutSegloop:0, F4 OutRDI:0
OAM cell drops:0
Status:UP
PPPOE enabled.
DBS enabled.

```

Step 2 Enter the **show atm pvc dbs** command to display information about ATM PVCs that have DBS QoS parameters applied:

Example:

```

Router# show atm pvc dbs

```

Interface	VCD / Name	VPI	VCI	Type	Encaps	SC	Peak Kbps	Avg/Min Kbps	Burst Cells
1/0.7	3	0	75	PVC	MUX	VBR	2000	700	94

```

UP

```

Step 3 Enter the **show running-config** command to verify that DBS QoS parameters have been applied. If you enter the **dbs enable** or the **no dbs enable** command, it appears in the output of the **show running-config** command. If you enter the **default dbs enable** command, it does not appear.

Example:

```

Router# show running-config
Building configuration...
Current configuration : 2902 bytes
!
version 12.2
no service single-slot-reload-enable
service timestamps debug uptime
service timestamps log uptime
no service password-encryption
!
hostname host1
!
aaa new-model
!
!
aaa authentication ppp default group radius
aaa authorization network default group radius
aaa session-id common
!
username usera password 0 password0
username lac password 0 password1
username lns password 0 password2
username nrp1 password 0 password3
username user1 password 0 password4
username nrp1-3 password 0 password5
username xyz@abc.com password 0 password6
ip subnet-zero

```



```
no ip mroute-cache
pvc 0/95
  class-vc pppoa
  ubr 5000
!
!
interface ATM1/0.10 point-to-point
no ip route-cache
no ip mroute-cache
range pvc 0/101 0/500
  class-range pppoe
!
  pvc-in-range 0/102
  no dbs enable
!
!
interface Virtual-Templat1
ip unnumbered Loopback1
ip mtu 1492
no keepalive
peer default ip address pool local_pool
ppp authentication chap
!
interface Virtual-Template2
ip address negotiated
ip mtu 1492
peer default ip address pool local_pool
ppp authentication chap
!
interface Virtual-Template10
ip address 192.168.11.1 255.255.255.0
no keepalive
peer default ip address pool p3
ppp authentication chap
!
interface Virtual-Template11
ip address negotiated
no keepalive
ppp chap hostname host1
ppp chap password password1
!
ip local pool p3 192.168.0.0 192.170.12.250
ip local pool local_pool 150.10.3.1 150.10.10.250
ip default-gateway 10.0.74.1
ip classless
ip route 10.0.0.0 10.0.0.0 10.0.74.1
ip route 10.107.164.0 255.255.255.0 FastEthernet0/0
no ip http server
!
!
!
radius-server host 172.18.0.0 auth-port 1645 acct-port 1646
radius-server retransmit 3
radius-server key cisco
call rsvp-sync
!
!
mgcp profile default
!
!
gatekeeper
  shutdown
!
!
line con 0
line aux 0
line vty 5 15
!
```

```
!
end
```

Monitoring DBS

Use the commands listed below to monitor DBS:

Command	Purpose
debug atm events	Displays the normal set of ATM events when a session comes up or goes down.
debug atm errors	Displays protocol errors and error statistics associated with VCs.
debug atm status	Displays changes in the status of a VC when a session comes up or goes down or when the VC configuration is changed.
debug ppp authentication	Displays authentication protocol messages, including Challenge Authentication Protocol (CHAP) packet exchanges and Password Authentication Protocol (PAP) exchanges.
debug ppp error	Displays protocol errors and error statistics associated with PPP connection negotiation and operation.
debug ppp negotiation	Enables debugging of PPP negotiation process.
debug radius	Displays detailed debugging information associated with RADIUS.
debug vpdn event	Displays Layer 2 tunneling protocol (L2TP) errors and events that are a part of normal tunnel establishment or shutdown for VPDNs.
debug vpdn l2x-errors	Displays Layer 2 forwarding protocol (L2F) and L2TP errors that prevent tunnel establishment or normal operation.
debug vpdn l2x-events	Displays L2F and L2TP events that are part of tunnel establishment or shutdown.
debug vpdn pppoe-errors	Displays PPPoE protocol errors that prevent a session from being established or errors that cause an established session to be closed.

Command	Purpose
<code>debug vpdn pppoe-events</code>	Displays PPPoE protocol messages about events that are part of normal session establishment or shutdown.
<code>show atm pvc</code>	Displays all ATM PVCs and traffic information.
<code>show atm pvc dbs</code>	Displays ATM PVCs that have DBS QoS parameters applied.
<code>show atm vc detailed</code>	Displays information about ATM PVCs and SVCs.
<code>show interfaces virtual-access</code>	Displays status, traffic data, and configuration information about a specified virtual access interface.

Configuration Examples for Controlling Subscriber Bandwidth

Configuring DBS for a VC Class Example

In the following example, DBS QoS parameters have been applied to a VC called "cisco":

```
vc-class atm cisco
dbs enable
```

Configuring DBS for a PVC Example

In the following example, DBS QoS parameters have been applied on a PVC called "cisco":

```
interface atm0/0/0.5 point-to-point
ip address 10.0.0.0 255.255.255.0
pvc cisco 0/100
dbs enable
protocol pppoe
```

Configuring DBS for a Range of PVCs Example

In the following example, DBS QoS parameters have been applied on a range of PVCs. The range is named "cisco range" and has a *start-vpi* of 0, a *start-vci* of 50, an *end-vpif* of 0, and an *end-vci* of 70:

```
interface atm0/0/0.1 multipoint
ip address 10.0.0.0 255.255.255.0
range cisco pvc 0/50 0/70
dbs enable
```

Configuring DBS for a PVC Within a PVC Range Example

In the following example, DBS parameters have been applied on PVC 60, which is part of the PVC range called "cisco":

```
interface atm0/0/0.1 multipoint
 range cisco pvc 0/50 0/70
 pvc-in-range 0/60
 dbs enable
```

Configuring RADIUS Attributes Examples

The following example shows how to configure RADIUS attributes for a domain profile for DBS:

```
cisco.com Password = "cisco", Service-Type = Outbound
 Service-Type = Outbound,
 Cisco-Avpair = "vpdn:tunnel-id=tunnel133",
 Cisco-Avpair = "vpdn:tunnel-type=l2tp",
 Cisco-Avpair = "vpdn:l2tp-tunnel-password=password2",
 Cisco-Avpair = "vpdn:ip-addresses=172.16.0.0",
 Cisco-Avpair = "atm:peak-cell-rate=155000",
 Cisco-Avpair = "atm:sustainable-cell-rate=155000"
```

The following example shows how to configure RADIUS attributes for a user profile for DBS:

```
user1@cisco.com Password = "userpassword1", Service-Type = Outbound
 Service-Type = Outbound,
 Cisco-Avpair = "atm:peak-cell-rate=155000",
 Cisco-Avpair = "atm:sustainable-cell-rate=155000"
```

Additional References

Related Documents

Related Topic	Document Title
Cisco IOS commands	Cisco IOS Master Commands List, All Releases
Cisco Subscriber Edge Services Manager	Cisco Subscriber Edge Services Manager
Access Point Name Manager	APN Manager Application Programming Guide
RADIUS configuration	<i>"Configuring RADIUS" chapter of the Cisco IOS Security Configuration Guide</i>
RADIUS attributes	<i>"RADIUS Attributes" appendix to the Cisco IOS Security Configuration Guide</i>
Broadband access aggregation concepts	<i>"Understanding Broadband Access Aggregation" module</i>

Related Topic	Document Title
Tasks for preparing for broadband access aggregation	"Preparing for Broadband Access Aggregation" <i>module</i>
Broadband access commands: complete command syntax, command mode, command history, defaults, usage guidelines, and examples	"Wide-Area Networking Commands" in the <i>Cisco IOS Wide-Area Networking Command Reference</i>

Standards

Standards	Title
None	--

MIBs

MIBs	MIBs Link
None	To locate and download MIBs for selected platforms, Cisco IOS XE software releases, and feature sets, use Cisco MIB Locator found at the following URL: http://www.cisco.com/go/mibs

RFCs

RFCs	Title
None	--

Technical Assistance

Description	Link
<p>The Cisco Support website provides extensive online resources, including documentation and tools for troubleshooting and resolving technical issues with Cisco products and technologies.</p> <p>To receive security and technical information about your products, you can subscribe to various services, such as the Product Alert Tool (accessed from Field Notices), the Cisco Technical Services Newsletter, and Really Simple Syndication (RSS) Feeds.</p> <p>Access to most tools on the Cisco Support website requires a Cisco.com user ID and password.</p>	<p>http://www.cisco.com/cisco/web/support/index.html</p>

Feature Information for Controlling Subscriber Bandwidth

The following table provides release information about the feature or features described in this module. This table lists only the software release that introduced support for a given feature in a given software release train. Unless noted otherwise, subsequent releases of that software release train also support that feature.

Use Cisco Feature Navigator to find information about platform support and Cisco software image support. To access Cisco Feature Navigator, go to www.cisco.com/go/cfn. An account on Cisco.com is not required.

Table 45: Feature Information for Controlling Subscriber Bandwidth

Feature Name	Releases	Feature Configuration Information
Dynamic Subscriber Bandwidth Selection (DBS)	Cisco IOS XE Release 2.5	This feature enables wholesale service providers to sell different classes of service to retail service providers by controlling bandwidth at the ATM virtual circuit (VC) level. ATM quality of service (QoS) parameters from the subscriber domain are applied to the ATM PVC on which a PPPoE or PPPoA session is established.



PPPoE Service Selection

The PPPoE Service Selection feature uses service tags to enable a PPP over Ethernet (PPPoE) server to offer PPPoE clients a selection of services during call setup. You choose one of the services offered, and the service is provided when the PPPoE session becomes active. This feature enables service providers to offer a variety of services and to charge you according to the service chosen.

- [Finding Feature Information, page 437](#)
- [Prerequisites for PPPoE Service Selection, page 437](#)
- [Information About PPPoE Service Selection, page 438](#)
- [How to Offer PPPoE Service Selection, page 441](#)
- [Configuration Examples for PPPoE Service Selection, page 451](#)
- [Where to Go Next, page 453](#)
- [Additional References, page 454](#)
- [Feature Information for PPPoE Service Selection, page 455](#)

Finding Feature Information

Your software release may not support all the features documented in this module. For the latest caveats and feature information, see [Bug Search Tool](#) and the release notes for your platform and software release. To find information about the features documented in this module, and to see a list of the releases in which each feature is supported, see the feature information table.

Use Cisco Feature Navigator to find information about platform support and Cisco software image support. To access Cisco Feature Navigator, go to www.cisco.com/go/cfn. An account on Cisco.com is not required.

Prerequisites for PPPoE Service Selection

- PPPoE must be configured using PPPoE profile configuration rather than virtual private dial-up network (VPDN) group configuration as described in the "Providing Protocol Support for Broadband Aggregation of PPPoE Sessions" module.

- The PPPoE client must support service tags in the PPPoE discovery phase.
- The procedures in this document assume that RADIUS accounting and authentication, and PPPoE are configured and working, if you use PPPoE service selection to offer tunneling services.
- You must configure either the **subscriber authorization enable** or the **vpdn enable** command before configuring PPPoE service selection to successfully create service names.

Information About PPPoE Service Selection

PPPoE Service Selection Through Service Tags

PPPoE service selection enables a PPPoE server to offer clients a selection of services during call setup. The PPPoE client chooses one of the services offered, and that service is provided when the PPPoE session becomes active.

PPPoE service selection works through the exchange of service tags during the PPPoE discovery phase. When a client initiates a call with a PPPoE Active Discovery Initiation (PADI) packet, the PPPoE server responds with a PPPoE Active Discovery Offer (PADO) packet that advertises a list of available services. The client selects a service and sends a PPPoE Active Discovery Request (PADR) packet that indicates the service name that was selected.

When the PPPoE server receives the PADR packet that indicates the chosen service, the PPPoE server handles the service name in the same manner as a domain name. The service profile for the service name is retrieved from a RADIUS server, and the attributes within that service profile are applied to the call.

PPPoE Service Names

Each PPPoE service has a service name, which can be defined as a set of characteristics that are applied to a PPPoE connection when that service name is selected during call setup.

When you configure PPPoE service selection, you can define a RADIUS service profile for each service name, list in a subscriber profile the service names that you want to advertise, and then assign the subscriber profile to a PPPoE profile. The PPPoE server advertises the service names that are listed in the subscriber profile to each PPPoE client connection that uses the configured PPPoE profile.

If a subscriber profile is not assigned to a PPPoE profile, the PPPoE connections that use that PPPoE profile are established without the additional service tags in the discovery packets. If a port is configured with a static service name (using the **vpn service** command), the static service name takes precedence, and no services are advertised to the client.

The Cisco RADIUS vendor-specific attribute (VSA) "service-name" is used in RADIUS accounting records to log the service name that was selected by the client. This attribute is also used to download the service names from the subscriber profile when the subscriber profile is defined on the RADIUS server.

You can use the **pppoe-client dial-pool-number** command to configure a PPPoE client. While configuring the PPPoE client, you can also specify the service name requested by the PPPoE client. This service name allows the PPPoE client to signal a service name to the Broadband Access Aggregation System (BRAS). By default, no service name is signaled and the service name value is set to NULL.

A single Permanent Virtual Connection (PVC) can support multiple PPPoE clients and redundancy. You can use the **pppoe-client dial-pool-number** command to configure one or more concurrent client PPPoE sessions on a single Asynchronous Transfer Mode (ATM) PVC.

RADIUS Service Profiles for PPPoE Service Selection

A service profile must be created on the RADIUS server for each service name. The service profile contains attributes that define how the call is handled. Currently, two sets of attributes are available for defining service profiles: attributes that define tunneling and attributes that define the quality of service (QoS) that is applied to the permanent virtual circuit (PVC) on which the PPPoE call is coming in.

The table below lists some of the attributes that are supported in RADIUS service profiles for PPPoE service selection.

Benefits of PPPoE Service Selection

PPPoE service selection enables a service provider to use PPPoE to offer a selection of services to you and to charge you according to the service selected. For example, a wholesaler could offer different levels of service by defining multiple service profiles for the same tunnel but with different levels of QoS for the ATM PVC. The wholesaler would be able to charge you according to the level of service provided.

PPPoE service selection could also be used by access providers to avoid link control protocol (LCP) negotiation at the Layer 2 Tunnel Protocol (L2TP) access concentrator (LAC) for sessions that are to be forwarded to tunnels. Avoiding LCP negotiation at the LAC can improve scalability of the LAC during call setup and help alleviate the load on the LAC while all the sessions on the LAC are reconnecting after an outage.

Attributes Used to Define a RADIUS Service Profile for PPPoE Selection

The table below lists some of the attributes that can be used to define a RADIUS service profile for PPPoE service selection. These attributes are defined when setting up the RADIUS server.

Table 46: Attributes for the RADIUS Service Profile for PPPoE Service Selection

RADIUS Entry	Purpose
<code>User-Service-Type = Outbound-User</code>	Configures the service type as outbound.
<code>Cisco-AVpair = "vpdn:tunnel-id= name "</code>	Specifies the name of the tunnel that must match the LNS's VPDN terminate-from hostname.
<code>Cisco-AVpair = "vpdn:tunnel-type=l2tp"</code>	Specifies Layer 2 Tunnel Protocol (L2TP).
<code>Cisco-AVpair = "vpdn:ip-addresses= ip-address "</code>	Specifies the IP address of L2TP network server (LNS).
<code>Cisco-AVpair = "atm:peak-cell-rate= kbps "</code>	Specifies the peak cell rate, in kbps, that is applied to the ATM PVC on which a PPPoE session is being established.
<code>Cisco-AVpair = "atm:sustainable-cell-rate= kbps "</code>	Specifies the sustainable cell rate, in kbps, that is applied to the ATM PVC on which a PPPoE session is being established.

Attributes Used to Configure a Subscriber Profile on the RADIUS Server for PPPoE Service Selection

The table below lists the attributes that can be used to configure a RADIUS subscriber profile to support PPPoE service selection.

The default AAA authorization method list determines where the policy manager looks for the subscriber profile. When the subscriber profile is configured remotely, the **aaa authorization network default group radius** command must be included in the AAA configuration so the policy manager knows to look for the subscriber policy on a AAA server. These attributes are defined while configuring the RADIUS server. Refer to the RADIUS server documentation for information about how to perform this configuration.

Table 47: Attributes for the RADIUS Subscriber Profile for PPPoE Service Selection

RADIUS Entry	Purpose
<code>User-Service-Type = Outbound-User</code>	Configures the service type as outbound.
<code>Cisco-AVpair = "pppoe:service-name= service-name "</code>	Specifies a PPPoE service name that is listed in this subscriber profile.

How to Offer PPPoE Service Selection

Configuring the Subscriber Profile for PPPoE Service Selection

The subscriber profile contains the list of services that is advertised to PPPoE clients. You can configure the subscriber profile locally on the router or on the RADIUS server.

If the services are defined locally and the subscriber services points to RADIUS server, the PPPoE services must come from RADIUS which is not been defined, empty, or unavailable for specific reason. You can configure either the **subscriber authorization enable** or the **vpdn enable** command before configuring PPPoE service selection to successfully create service names.

Perform this task to configure a local subscriber profile for PPPoE service selection.

Before You Begin

The default AAA authorization method list determines where the policy manager looks for the subscriber profile. When the subscriber profile is configured locally, the **aaa authorization network default local** command must be included in the AAA configuration so the policy manager knows to look for the subscriber policy locally.

SUMMARY STEPS

1. **enable**
2. **configure terminal**
3. **policy-map type service** *policy-map-name*
4. **pppoe service** *service-name*
5. Repeat Step 4 for each service name that you want to add to the subscriber profile.
6. **end**
7. **end**

DETAILED STEPS

	Command or Action	Purpose
Step 1	<p>enable</p> <p>Example:</p> <pre>Router> enable</pre>	<p>Enables privileged EXEC mode.</p> <ul style="list-style-type: none"> • Enter your password if prompted.
Step 2	<p>configure terminal</p> <p>Example:</p> <pre>Router# configure terminal</pre>	<p>Enters global configuration mode.</p>

	Command or Action	Purpose
Step 3	<p>policy-map type service <i>policy-map-name</i></p> <p>Example:</p> <pre>Router(config)# policy-map type service abc</pre>	Enters service policy map configuration mode and creates or modifies a service policy map, which is used to define an Intelligent Services Gateway (ISG) subscriber service.
Step 4	<p>pppoe service <i>service-name</i></p> <p>Example:</p> <pre>Router(config-service-policymap)# pppoe service gold-isp-A</pre>	Adds a PPPoE service name to a subscriber profile.
Step 5	Repeat Step 4 for each service name that you want to add to the subscriber profile.	--
Step 6	<p>end</p> <p>Example:</p> <pre>Router(config-service-policymap)# end</pre>	(Optional) Terminates the configuration session and returns to global configuration mode.
Step 7	<p>end</p> <p>Example:</p> <pre>Router(config)# end</pre>	(Optional) Exits global configuration mode.

Configuring the PPPoE Profile for PPPoE Service Selection

Perform this task to associate a subscriber profile with a PPPoE profile.

SUMMARY STEPS

1. **enable**
2. **configure terminal**
3. **bba-group pppoe** *{group-name | global}*
4. **virtual-template** *template-number*
5. **sessions per-vc limit** *number*
6. **service profile** *subscriber-profile-name* [**refresh** *minutes*]
7. **end**
8. **end**

DETAILED STEPS

	Command or Action	Purpose
Step 1	enable Example: Router> enable	Enables privileged EXEC mode. <ul style="list-style-type: none"> • Enter your password if prompted.
Step 2	configure terminal Example: Router# configure terminal	Enters global configuration mode.
Step 3	bba-group pppoe { <i>group-name</i> global } Example: Router(config)# bba-group pppoe group1	Defines a PPPoE profile and enters BBA group configuration mode. <ul style="list-style-type: none"> • The global keyword creates a profile that serves as the default profile for any PPPoE port that is not assigned a specific profile.
Step 4	virtual-template <i>template-number</i> Example: Router(config-bba-group)# virtual-template 1	Specifies which virtual template is used to clone virtual access interfaces for all PPPoE ports that use this PPPoE profile.
Step 5	sessions per-vc limit <i>number</i>	Sets the maximum number of PPPoE sessions to be established over a VC in a PPPoE profile.
Step 6	service profile <i>subscriber-profile-name</i> [refresh <i>minutes</i>] Example: Router(config-bba-group)# service profile subscriber-group1	Assigns a subscriber profile to a PPPoE profile. <ul style="list-style-type: none"> • The PPPoE server advertises the service names that are listed in the subscriber profile to each PPPoE client connection that uses the configured PPPoE profile. • The PPPoE configuration that is derived from the subscriber <code>gold_isp_A</code> (where gold services created using the Cisco Distributed Administrative Tool (CDAT) interface are defined) under the PPPoE profile. Use the service profile command with the refresh keyword and the <i>minutes</i> argument to cause the cached PPPoE configuration to be timed out after a specified number of minutes.
Step 7	end Example: Router(config-bba-group)# end	(Optional) Returns to global configuration mode.

	Command or Action	Purpose
Step 8	end Example: Router(config)# end	(Optional) Exits global configuration mode.

Troubleshooting Tips

Use the **show pppoe session** and **debug pppoe** commands to troubleshoot PPPoE sessions.

What to Do Next

Once a PPPoE profile has been defined, it must be assigned to a PPPoE port (Fast Ethernet, virtual LAN [VLAN], or PVC), a virtual circuit (VC) class, or an ATM PVC range. For more information about how to configure PPPoE profiles, refer to the Providing Protocol Support for Broadband Access Aggregation of PPPoE Sessions chapter.

Configuring Service Names for PPPoE Clients on an ATM PVC

Perform this task to configure the service name for PPPoE client on an ATM PVC.

SUMMARY STEPS

1. **enable**
2. **configure terminal**
3. **interface atm** *number*
4. **pvc** [*name*] *vpi* / *vci*
5. **pppoe-client dial-pool-number** *number* **restart** *number* **service-name** *name*
6. **end**

DETAILED STEPS

	Command or Action	Purpose
Step 1	enable Example: Router> enable	Enables privileged EXEC mode. <ul style="list-style-type: none"> • Enter your password if prompted.

	Command or Action	Purpose
Step 2	<p>configure terminal</p> <p>Example:</p> <pre>Router# configure terminal</pre>	Enters global configuration mode.
Step 3	<p>interface atm <i>number</i></p> <p>Example:</p> <pre>Router(config)# interface atm 0</pre>	Configures an ATM interface.
Step 4	<p>pvc [<i>name</i>] vpi / vci</p> <p>Example:</p> <pre>Router(config-if)# pvc 1/100</pre>	Creates an ATM PVC and enters ATM virtual circuit configuration.
Step 5	<p>pppoe-client dial-pool-number <i>number</i> restart <i>number</i> service-name <i>name</i></p> <p>Example:</p> <pre>Router(config-if-atm-vc)# pppoe-client dial-pool-number 1 restart 80 service-name "test 4"</pre>	<p>Configures the PPPoE client, specifies the dialer interface number, restart number, and service name to use for cloning on the PVC.</p> <p>Note</p> <ul style="list-style-type: none"> • The dial-pool number is the number that is assigned to a configured dialer pool. The range is from 1 to 255. • The restart number is the timer configured in seconds. The range is from 1 to 3600 and default value is 20. • The name indicates the service-name requested by the PPPoE client. The service name allows the PPPoE client to signal a service name to the Broadband Access Aggregation System (BRAS). By default, no service name is signaled and the service name value is set to NULL.
Step 6	<p>end</p> <p>Example:</p> <pre>Router(config-if-atm-vc)# end</pre>	Returns to privileged EXEC mode.

What to Do Next



Note If you make any changes to the PVC configuration after the PPPoE client session is established, the session is automatically terminated and reestablished.

Verifying PPPoE Service Selection

Perform this task to verify PPPoE service selection configuration and performance. Steps 2 through 3 are optional and do not have to be performed in a particular order.

SUMMARY STEPS

1. **show pppoe derived group group-name**
2. **show vpdn [session [all | packets | sequence | state] | tunnel [all | packets | summary | state | transport]]**
3. **show atm pvc [vpi / vci | name | interface atm slot/subslot/port[. subinterface multipoint]] [ppp]**

DETAILED STEPS

Step 1 **show pppoe derived group group-name**
 (Optional) Displays the cached PPPoE configuration that is derived from the subscriber profile for a specified PPPoE profile.
 This command is useful for viewing the subscriber profile configuration when the subscriber profile is configured on a remote AAA server.

Example:

```
Router# show pppoe derived group sp-group-a
Derived configuration from subscriber profile 'abc':
Service names:
  isp-xyz, gold-isp-A, silver-isp-A
```

Step 2 **show vpdn [session [all | packets | sequence | state] | tunnel [all | packets | summary | state | transport]]**
 (Optional) Displays information about active L2TP or Layer 2 Forwarding (L2F) Protocol tunnel and message identifiers in a VPDN.
 Use this command to display tunneling parameters for the services configured for tunneling.

Example:

```
Router# show vpdn
Active L2F tunnels
NAS Name   Gateway Name   NAS CLID   Gateway CLID   State
nas        gateway        4          2              open
L2F MIDs
Name       NAS Name      Interface  MID            State
router1@cisco.com  nas          As7       1              open
router2@cisco.com  nas          As8       2              open
```

Step 3 **show atm pvc [vpi / vci | name | interface atm slot/subslot/port[. subinterface multipoint]] [ppp]**
 (Optional) Displays all ATM PVCs and traffic information.
 Use this command to display ATM QoS parameters for the services configured for ATM QoS.

Example:

```
Router# show atm pvc
VCD/
Interface Name  VPI  VCI  Type  Encaps  Peak Kbps  Avg/Min Kbps  Burst Cells  Sts
```

2/0	1	0	5	PVC	SAAL	155000	155000	UP
2/0	2	0	16	PVC	ILMI	155000	155000	UP
2/0.2	101	0	50	PVC	SNAP	155000	155000	UP
2/0.2	102	0	60	PVC	SNAP	155000	155000	DOWN
2/0.2	104	0	80	PVC	SNAP	155000	155000	UP
2/0	hello	0	99	PVC	SNAP	1000		

Monitoring and Maintaining PPPoE Service Selection

To monitor and maintain PPPoE service selection, perform the following steps.

SUMMARY STEPS

1. **clear pppoe derived group** *group-name*
2. **debug pppoe events** [*rmac remote-mac-address* | **interface** *type number* [**vc** {[*vpi* /]*vci* | *vc-name*}] [**vlan** *vlan-id*]]
3. **debug radius** [**brief** | **hex**]

DETAILED STEPS

Step 1

clear pppoe derived group *group-name*

Clears the cached PPPoE configuration of a PPPoE profile and forces the PPPoE profile to reread the configuration from the assigned subscriber profile.

Example:

```
Router# clear pppoe derived group group1
```

Step 2

debug pppoe events [*rmac remote-mac-address* | **interface** *type number* [**vc** {[*vpi* /]*vci* | *vc-name*}] [**vlan** *vlan-id*]]

(Optional) Displays PPPoE protocol messages about events that are part of normal session establishment or shutdown.

Use this command to monitor the exchange of PPPoE service names during call setup.

Example:

```
Router# debug pppoe events interface atm 0/0.0 vc 101
```

```
PPPoE protocol events debugging is on
Router#
00:41:55:PPPoE 0:I PADI R:00b0.c2e9.c470 L:ffff.ffff.ffff 0/101 ATM0/1/0.10
00:41:55:PPPoE 0:O PADO, R:00b0.c2e9.c470 L:0001.c9f0.0c1c 0/101 ATM0/1/0.10
00:41:55:PPPoE 0:I PADR R:00b0.c2e9.c470 L:0001.c9f0.0c1c 0/101 ATM0/1/0.10
00:41:55:PPPoE :encap string prepared
00:41:55:[3]PPPoE 3:Access IE handle allocated
00:41:55:[3]PPPoE 3:pppoe SSS switch updated
00:41:55:[3]PPPoE 3:AAA unique ID allocated
00:41:55:[3]PPPoE 3:No AAA accounting method list
00:41:55:[3]PPPoE 3:Service request sent to SSS
00:41:55:[3]PPPoE 3:Created R:0001.c9f0.0c1c L:00b0.c2e9.c470 0/101 ATM0/1/0.10
00:41:55:[3]PPPoE 3:State REQ_NASPORT Event MORE_KEYS
00:41:55:[3]PPPoE 3:O PADS R:00b0.c2e9.c470 L:0001.c9f0.0c1c 0/101 ATM0/1/0.10
00:41:55:[3]PPPoE 3:State START_PPP Event DYN_BIND
```

```
00:41:55:[3]PPPoE 3:data path set to PPP
00:41:57:[3]PPPoE 3:State LCP_NEGO      Event PPP_LOCAL
00:41:57:PPPoE 3/SB:Sent vtemplate request on base Vi2
00:41:57:[3]PPPoE 3:State CREATE_VA    Event VA_RESP
00:41:57:[3]PPPoE 3:Vi2.1 interface obtained
00:41:57:[3]PPPoE 3:State PTA_BIND     Event STAT_BIND
00:41:57:[3]PPPoE 3:data path set to Virtual Access
00:41:57:[3]PPPoE 3:Connected PTA
```

Step 3 **debug radius [brief | hex]**

(Optional) Displays information associated with RADIUS.

Use this command to monitor the transactions between the router and the RADIUS server.

Example:

```
Router# debug radius

Radius protocol debugging is on
Radius packet hex dump debugging is off
Router#
00:02:50: RADIUS: ustruct sharecount=3
00:02:50: Radius: radius_port_info() success=0 radius_nas_port=1
00:02:50: RADIUS: Initial Transmit ISDN 0:D:23 id 0 10.0.0.0:0000, Accounting-Request, len
358
00:02:50: RADIUS: NAS-IP-Address [4] 6 10.0.0.0
00:02:50: RADIUS: Vendor, Cisco [26] 19 VT=02 TL=13 ISDN 0:D:23
00:02:50: RADIUS: NAS-Port-Type [61] 6 Async
00:02:50: RADIUS: User-Name [1] 12 "5559999999"
00:02:50: RADIUS: Called-Station-Id [30] 7 "52981"
00:02:50: RADIUS: Calling-Station-Id [31] 12 "5559999999"
00:02:50: RADIUS: Acct-Status-Type [40] 6 Start
00:02:50: RADIUS: Service-Type [6] 6 Login
00:02:50: RADIUS: Vendor, Cisco [26] 27 VT=33 TL=21 h323-gw-id=5300_43.
00:02:50: RADIUS: Vendor, Cisco [26] 55 VT=01 TL=49
h323-incoming-conf-id=8F3A3163 B4980003 0 29BD0
00:02:50: RADIUS: Vendor, Cisco [26] 31 VT=26 TL=25 h323-call-origin=answer
00:02:50: RADIUS: Vendor, Cisco [26] 32 VT=27 TL=26 h323-call-type=Telephony
00:02:50: RADIUS: Vendor, Cisco [26] 57 VT=25 TL=51 h323-setup-time=*16:02:48.681
PST Fri Dec 31 1999
00:02:50: RADIUS: Vendor, Cisco [26] 46 VT=24 TL=40 h323-conf-id=8F3A3163
B4980003 0 29BD0
00:02:50: RADIUS: Acct-Session-Id [44] 10 "555599999"
00:02:50: RADIUS: Delay-Time [41] 6 0
00:02:51: RADIUS: Received from id 0 0.0.000.0:0000, Accounting-response, len 20
00:02:51: %ISDN-6-CONNECT: Interface Serial0:22 is now connected to 5559000000
00:03:01: RADIUS: ustruct sharecount=3
00:03:01: Radius: radius_port_info() success=0 radius_nas_port=1
00:03:01: RADIUS: Initial Transmit ISDN 0:D:23 id 1 0.0.000.0:0000, Access-Request, len
171
00:03:01: RADIUS: NAS-IP-Address [4] 6 10.x.y.z
00:03:01: RADIUS: Vendor, Cisco [26] 19 VT=02 TL=13 ISDN 0:D:23
00:03:01: RADIUS: NAS-Port-Type [61] 6 Async
00:03:01: RADIUS: User-Name [1] 8 "123456"
00:03:01: RADIUS: Vendor, Cisco [26] 46 VT=24 TL=40 h323-conf-id=8F3A3163
B4980003 0 29BD0
00:03:01: RADIUS: Calling-Station-Id [31] 12 "555999999"
00:03:01: RADIUS: User-Password [2] 18 *
00:03:01: RADIUS: Vendor, Cisco [26] 36 VT=01 TL=30 h323-ivr-out=transactionID:0
00:03:01: RADIUS: Received from id 0 0.0.000.0 1:1823, Access-Accept, len 115
00:03:01: RADIUS: Service-Type [6] 6 Login
00:03:01: RADIUS: Vendor, Cisco [26] 29 VT=101 TL=23 h323-credit-amount=45
00:03:01: RADIUS: Vendor, Cisco [26] 27 VT=102 TL=21 h323-credit-time=33
00:03:01: RADIUS: Vendor, Cisco [26] 26 VT=103 TL=20 h323-return-code=0
00:03:01: RADIUS: Class [25] 7 6C6F63616C
00:03:01: RADIUS: saved authorization data for user 62321E14 at 6233D258
00:03:13: %ISDN-6-DISCONNECT: Interface Serial0:22 disconnected from 5559000000, call
lasted 22 seconds
00:03:13: RADIUS: ustruct sharecount=2
```



```

00:03:13: Radius: radius_port_info() success=0 radius_nas_port=1
00:03:13: RADIUS: Sent class "local" at 6233D2C4 from user 62321E14
00:03:13: RADIUS: Initial Transmit ISDN 0:D:23 id 0 0.0.000.0:0000, Accounting-Request,
len 775
00:03:13: RADIUS: NAS-IP-Address [4] 6 10.0.0.0
00:03:13: RADIUS: Vendor, Cisco [26] 19 VT=02 TL=13 ISDN 0:D:23
00:03:13: RADIUS: NAS-Port-Type [61] 6 Async
00:03:13: RADIUS: User-Name [1] 8 "123456"
00:03:13: RADIUS: Called-Station-Id [30] 7 "52981"
00:03:13: RADIUS: Calling-Station-Id [31] 12 "5559000000"
00:03:13: RADIUS: Acct-Status-Type [40] 6 Stop
00:03:13: RADIUS: Class [25] 7 6C6F63616C
00:03:13: RADIUS: Undebuggable [45] 6 00000001
00:03:13: RADIUS: Service-Type [6] 6 Login
00:03:13: RADIUS: Vendor, Cisco [26] 27 VT=33 TL=21 h323-gw-id=5300_43.
00:03:13: RADIUS: Vendor, Cisco [26] 55 VT=01 TL=49
h323-incoming-conf-id=8F3A3163 B4980003 0 29BD0
00:03:13: RADIUS: Vendor, Cisco [26] 31 VT=26 TL=25 h323-call-origin=answer
00:03:13: RADIUS: Vendor, Cisco [26] 32 VT=27 TL=26 h323-call-type=Telephony
00:03:13: RADIUS: Vendor, Cisco [26] 57 VT=25 TL=51 h323-setup-time=*16:02:48.681
PST Fri Dec 31 1999
00:03:13: RADIUS: Vendor, Cisco [26] 59 VT=28 TL=53
h323-connect-time=*16:02:48.946 PST Fri Dec 31 1999
00:03:13: RADIUS: Vendor, Cisco [26] 62 VT=29 TL=56in=0
00:03:13: RADIUS: Vendor, Cisco [26] 23 VT=01 TL=17 pre-bytes-out=0
00:03:13: RADIUS: Vendor, Cisco [26] 21 VT=01 TL=15 pre-paks-in=0
00:03:13: RADIUS: Vendor, Cisco [26] 22 VT=01 TL=16 pre-paks-out=0
00:03:13: RADIUS: Vendor, Cisco [26] 22 VT=01 TL=16 nas-rx-speed=0
00:03:13: RADIUS: Vendor, Cisco [26] 22 VT=01 TL=16 nas-tx-speed=0
00:03:13: RADIUS: Delay-Time [41] 6 0
00:03:13: RADIUS: Received from id 0 0.0.000.0:0000, Accounting-response, len 20
h323-disconnect-time=*16:03:11.306 PST Fri Dec 31 1999
00:03:13: RADIUS: Vendor, Cisco [26] 32 VT=30 TL=26 h323-disconnect-cause=10
00:03:13: RADIUS: Vendor, Cisco [26] 28 VT=31 TL=22 h323-voice-quality=0
00:03:13: RADIUS: Vendor, Cisco [26] 46 VT=24 TL=40 h323-conf-id=8F3A3163
B4980003 0 29BD0
00:03:13: RADIUS: Acct-Session-Id [44] 10 "00000000"
00:03:13: RADIUS: Acct-Input-Octets [42] 6 0
00:03:13: RADIUS: Acct-Output-Octets [43] 6 88000
00:03:13: RADIUS: Acct-Input-Packets [47] 6 0
00:03:13: RADIUS: Acct-Output-Packets [48] 6 550
00:03:13: RADIUS: Acct-Session-Time [46] 6 22
00:03:13: RADIUS: Vendor, Cisco [26] 30 VT=01 TL=24 subscriber=RegularLine
00:03:13: RADIUS: Vendor, Cisco [26] 35 VT=01 TL=29 h323-ivr-out=Tariff:Unknown
00:03:13: RADIUS: Vendor, Cisco [26] 22 VT=01 TL=16 pre-bytes-

```

The following is sample output from the **debug radius brief** command:

Example:

```

Router# debug radius brief
Radius protocol debugging is on
Radius packet hex dump debugging is off
Radius protocol in brief format debugging is on
00:05:21: RADIUS: Initial Transmit ISDN 0:D:23 id 0 00.0.0.0:0000, Accounting-Request, len
358
00:05:21: %ISDN-6-CONNECT: Interface Serial0:00 is now connected to 5559000000
00:05:26: RADIUS: Retransmit id 6
00:05:31: RADIUS: Tried all servers.
00:05:31: RADIUS: No valid server found. Trying any viable server
00:05:31: RADIUS: Tried all servers.
00:05:31: RADIUS: No response for id 7
00:05:31: RADIUS: Initial Transmit ISDN 0:D:00 id 0 00.0.0.0:0000, Access-Request, len 171
00:05:36: RADIUS: Retransmit id 8
00:05:36: RADIUS: Received from id 0 0.0.000.0:0000, Access-Accept, len 115
00:05:47: %ISDN-6-DISCONNECT: Interface Serial0:22 disconnected from 5559000000, call
lasted 26 seconds
00:05:47: RADIUS: Initial Transmit ISDN 0:D:00 id 0 00.0.0.0:0000, Accounting-Request, len

```

775

00:05:47: RADIUS: Received from id 0 0.0.000.0:0000, Accounting-response, len 20

The following example shows **debug radius hex** command output:

Example:

```

Router# debug radius hex
Radius protocol debugging is on
Radius packet hex dump debugging is on
Router#
17:26:52: RADIUS: ustruct sharecount=3
17:26:52: Radius: radius_port_info() success=0 radius_nas_port=1
17:26:52: RADIUS: Initial Transmit ISDN 0:D:00 id 0 00.0.0.0:0000, Accounting-Request,
len 361
17:26:52:      Attribute 4 6 01081D03
17:26:52:      Attribute 26 19 00000009020D4953444E20303A443A3233
17:26:52:      Attribute 61 6 00000000
17:26:52:      Attribute 1 12 34303835323734323036
17:26:52:      Attribute 30 7 3532393831
17:26:52:      Attribute 31 12 34303835323734323036
17:26:52:      Attribute 40 6 00000001
17:26:52:      Attribute 6 6 00000001
17:26:52:      Attribute 26 27 000000092115683332332D67772D69643D353330305F34332E
17:26:52:      Attribute 26 57
000000090133683332332D696E636F6D696E672D636F6E662D69643D3846334133313633204234393830303046
20302033424537314238
17:26:52:      Attribute 26 31
000000091A19683332332D63616C6C2D6F726967696E3D616E73776572
17:26:52:      Attribute 26 32
000000091B1A683332332D63616C6C2D747970653D54656C6570686F6E79
17:26:52:      Attribute 26 56
000000091932683332332D73657475702D74696D653D2A30393A32363A35322E383830202050535420536174204A
616E20312032303030
17:26:52:      Attribute 26 48
00000009182A683332332D636F6E662D69643D3846334133313633204234393830303046203020334245373142
38
:26:52:      Attribute 44 10 3030303030303035
17:26:52:      Attribute 41 6 00000000
17:26:52: %ISDN-6-CONNECT: Interface Serial0:22 is now connected to 0000000000
17:26:52: RADIUS: Received from id 10 10.0.0.1:1824, Accounting-response, len 20
17:27:01: RADIUS: ustruct sharecount=3
17:27:01: Radius: radius_port_info() success=0 radius_nas_port=1
17:27:01: RADIUS: Initial Transmit ISDN 0:D:23 id 11 10.0.0.0:1823, Access-Request, len
173
17:27:01:      Attribute 4 6 01081D03
17:27:01:      Attribute 26 19 00000009020D4953444E20303A443A3233
17:27:01:      Attribute 61 6 00000000
17:27:01:      Attribute 1 8 313233343536
17:27:01:      Attribute 26 48
00000009182A683332332D636F6E662D69643D3846334133313633204234393830303046203020334245373142
38
17:27:01:      Attribute 31 12 34303835323734323036
17:27:01:      Attribute 2 18 C980D8D0E9A061B3D783C61AA6F27214
17:27:01:      Attribute 26 36
00000009011E683332332D6976722D6F75743D7472616E73616374696F6E49443A33
17:27:01: RADIUS: Received from id 11 0.0.000.0:0000, Access-Accept, len 115
17:27:01:      Attribute 6 6 00000001
17:27:01:      Attribute 26 29 000000096517683332332D6372656469742D616D6F756E743D3435
17:27:01:      Attribute 26 27 000000096615683332332D6372656469742D74696D653D3333
17:27:01:      Attribute 26 26 000000096714683332332D72657475726E2D636F64653D30
17:27:01:      Attribute 25 7 6C6F63616C
17:27:01: RADIUS: saved authorization data for user 61AA0698 at 6215087C
17:27:09: %ISDN-6-DISCONNECT: Interface Serial0:22 disconnected from 5559999999, call
lasted 17 seconds
17:27:09: RADIUS: ustruct sharecount=2
17:27:09: Radius: radius_port_info() success=0 radius_nas_port=1
17:27:09: RADIUS: Sent class "local" at 621508E8 from user 61AA0698
17:27:09: RADIUS: Initial Transmit ISDN 0:D:23 id 12 0.0.000.0:0000, Accounting-Request,

```

```

len 776
17:27:09:      Attribute 4 6 01081D03
17:27:09:      Attribute 26 19 00000009020D4953444E20303A443A3233
17:27:09:      Attribute 61 6 00000000
17:27:09:      Attribute 1 8 313233343536
17:27:09:      Attribute 30 7 3532393831
17:27:09:      Attribute 31 12 34303835323734323036
17:27:09:      Attribute 40 6 00000002
17:27:09:      Attribute 25 7 6C6F63616C
17:27:09:      Attribute 45 6 00000001
17:27:09:      Attribute 6 6 00000001
17:27:09:      Attribute 26 27 000000092115683332332D67772D69643D353330305F34332E
17:27:09:      Attribute 26 57
000000090133683332332D696E636F6D696E672D636F6E662D69643D3846334133313633204234393830303046
20302033424537314238
17:27:09:      Attribute 26 31
000000091A19683332332D63616C6C2D6F726967696E3D616E73776572
17:27:09:      Attribute 26 32
000000091B1A683332332D63616C6C2D747970653D54656C6570686F6E79
17:27:09:      Attribute 26 56
000000091932683332332D73657475702D74696D653D2A30393A32363A35322E3838302050535420536174204A
616E20312032303030
17:27:09:      Attribute 26 58
000000091C34683332332D636F6E6E6563742D74696D653D2A30393A32363A35322E3930372050535420536174
204A616E20312032303030
17:27:09:      Attribute 26 61
000000091D37683332332D646973636F6E6E6563742D74696D653D2A30393A32373A31302E3133372050535420
536174204A616E20312032303030
17:27:09:      Attribute 26 32
000000091E1A683332332D646973636F6E6E6563742D63617573653D3130
17:27:09:      Attribute 26 28 000000091F16683332332D766F6963652D7175616C6974793D30
17:27:09:      Attribute 26 48
00000009182A683332332D636F6E662D69643D3846334133313633204234393830303046203020334245373142
38
17:27:09:      Attribute 44 10 3030303030303035
17:27:09:      Attribute 42 6 00000000
17:27:09:      Attribute 43 6 00012CA0
17:27:09:      Attribute 47 6 00000000
17:27:09:      Attribute 48 6 000001E1
17:27:09:      Attribute 46 6 00000011
17:27:09:      Attribute 26 30 000000090118737562736372696265723D526567756C61724C696E65
17:27:09:      Attribute 26 35
00000009011D683332332D6976722D6F75743D54617269666663A556E6B6E6F776E
17:27:09:      Attribute 26 22 0000000901107072652D62797465732D696E3D30
17:27:09:      Attribute 26 23 0000000901117072652D62797465732D6F75743D30
17:27:09:      Attribute 26 21 00000009010F7072652D70616B732D696E3D30
17:27:09:      Attribute 26 22 0000000901107072652D70616B732D6F75743D30
17:27:09:      Attribute 26 22 0000000901106E61732D72782D73706565643D30
17:27:09:      Attribute 26 22 0000000901106E61732D74782D73706565643D30
17:27:09:      Attribute 41 6 00000000
17:27:09: RADIUS: Received from id 12 10.0.0.1:1824, Accounting-response, len 20

```

Configuration Examples for PPPoE Service Selection

Example PPPoE Service Selection with ATM QoS and Tunneling Services

In the following example, three services are configured: gold-isp-A, silver-isp-A, and isp-xyz. The gold and silver services are forwarded onto the same tunnel, but the ATM PVCs between the LAC and DSLAM is set up with different QoS parameters depending on the level of service chosen. The isp-xyz service offers users access to the services of the xyz Internet service provider.

In this example, the subscriber profile is configured locally on the PPPoE server.

RADIUS Service Profile Configuration

```
gold-isp-A Password = "cisco", User-Service-type = Outbound-User
    Tunnel-Assignment-Id = nrp1-3,
    Cisco-Avpair = "vpdn:tunnel-id=nrp1-3",
    Cisco-Avpair = "vpdn:tunnel-type=l2tp",
    Cisco-Avpair = "vpdn:ip-addresses=10.1.1.4",
    Cisco-Avpair = "atm:peak-cell-rate =2500",
    Cisco:Cisco-Avpair = "atm:sustainable-cell-rate =400"
silver-isp-A Password = "cisco", User-Service-type = Outbound-User
    Cisco-Avpair = "vpdn:tunnel-id=nrp1-3",
    Cisco-Avpair = "vpdn:tunnel-type=l2tp",
    Cisco-Avpair = "vpdn:ip-addresses=10.1.1.4",
    Cisco:Cisco-Avpair = "atm:peak-cell-rate =1500",
    Cisco:Cisco-Avpair = "atm:sustainable-cell-rate =200"
isp-xyz Password = "cisco", User-Service-type = Outbound-User
    Cisco-Avpair = "vpdn:tunnel-id=aol",
    Cisco-Avpair = "vpdn:tunnel-type=l2tp",
    Cisco-Avpair = "vpdn:ip-addresses=10.1.1.5",
    Cisco:Cisco-Avpair = "atm:peak-cell-rate =1000",
    Cisco:Cisco-Avpair = "atm:sustainable-cell-rate =150"
```

PPPoE Server Configuration

```
!
! Configure the AAA default authorization method
aaa new-model
aaa authorization network default local
!
!subscriber authorization enable
! Configure the subscriber profile
policy-map type service listA
  pppoe service gold-isp-A
  pppoe service silver-isp-A
  pppoe service isp-xyz
!
! Configure the PPPoE profile
bba-group pppoe group-A
  virtual-template 1
  sessions per-vc limit 5
  service profile listA
! Attach the PPPoE profile to a PVC
interface atm0/0.0
  pvc 2/200
    protocol PPPoE group group-A
!
```

Example PPPoE Service Selection with Tunneling Services

In the following example, PPPoE service selection is used to provide tunneling services only. In this example, the subscriber profile is configured on the RADIUS server.

RADIUS Service Profile Configuration

```
tunnel-to-cust1 Password = "cisco", User-Service-type = Outbound-User
    Tunnel-Assignment-Id = nrp1-3,
    Cisco-Avpair = "vpdn:tunnel-id=nrp1-3",
    Cisco-Avpair = "vpdn:tunnel-type=l2tp",
    Cisco-Avpair = "vpdn:ip-addresses=10.1.1.4",
tunnel-to-cust2 Password = "cisco", User-Service-type = Outbound-User
    Cisco-Avpair = "vpdn:tunnel-id=xyz",
```

```

Cisco-Avpair = "vpdn:tunnel-type=l2tp",
Cisco-Avpair = "vpdn:ip-addresses=10.1.1.5",

tunnel-to-cust3 Password = "cisco", User-Service-type = Outbound-User
Cisco-Avpair = "vpdn:tunnel-id=aol",
Cisco-Avpair = "vpdn:tunnel-type=l2tp",
Cisco-Avpair = "vpdn:ip-addresses=10.1.1.6",

```

RADIUS Subscriber Profile Configuration

```

customer-tunnels Password = "cisco", User-Service-type = Outbound-User
Cisco:Cisco-Avpair = "pppoe:service-name=tunnel-to-cust1",
Cisco:Cisco-Avpair = "pppoe:service-name=tunnel-to-cust2",
Cisco:Cisco-Avpair = "pppoe:service-name=tunnel-to-cust3"

```

PPPoE Server Configuration

```

!
! Configure the AAA default authorization method
aaa new-model
aaa authorization network default group radius
!
! Configure the PPPoE profile
bba-group pppoe group-A
virtual-template 1
sessions per-vc 5
service profile customer-tunnels
!
! Attach the PPPoE profile to PVCs
interface atm0/1/0.10
pvc 2/200
protocol PPPoE group pppoe-group-A
!
interface atm0/1/0.10
pvc 3/300
protocol PPPoE group pppoe-group-A

```

Where to Go Next

- If you want to establish PPPoE sessions limits for sessions on a specific permanent virtual circuit or VLAN configured on an L2TP access concentrator, refer to the "Establishing PPPoE Session Limits per NAS Port" module.
- If you want to enable an L2TP access concentrator to relay active discovery and service selection functionality for PPPoE over an L2TP control channel to an LNS or tunnel switch, refer to the "Enabling PPPoE Relay Discovery and Service Selection Functionality" module.
- If you want to configure the transfer upstream of the Point-to-Point Protocol over X (family of encapsulating communications protocols implementing PPP)(PPPoX) session speed value, refer to the "Configuring Upstream Connections Speed Transfer" module.
- If you want to use the Simple Network Management Protocol (SNMP) to monitor PPPoE sessions, refer to the "Monitoring PPPoE Sessions with SNMP" module.
- If you want to identify a physical subscribe line for RADIUS communication with a RADIUS server, refer to the "Identifying a Physical Subscriber Line for RADIUS Access and Accounting" module.
- If you want to configure a Cisco Subscriber Service Switch, refer to the "Configuring Cisco Subscriber Service Switch Policies" module.

Additional References

Related Documents

Related Topic	Document Title
RADIUS attributes and configuration	<i>Cisco IOS XE Security Configuration Guide</i> , Release 2
Tunneling configuration	<i>Cisco IOS XE Dial Technologies Configuration Guide</i> , Release 2
Broadband access aggregation concepts, preparing for broadband access aggregation, and configuring PPPoE sessions	<i>Cisco IOS XE Broadband Access Aggregation and DSL Configuration Guide</i> , Release 2
Broadband access commands: complete command syntax, command mode, command history, defaults, usage guidelines, and examples	<i>Cisco IOS XE Broadband Access Aggregation and DSL Command Reference</i>

Standards

Standards	Title
No new or modified standards are supported by this feature. Support for existing standards has not been modified by this feature.	--

MIBs

MIBs	MIBs Link
No new or modified MIBs are supported by this feature. Support for existing MIBs has not been modified by this feature.	To locate and download MIBs for selected platforms, Cisco software releases, and feature sets, use Cisco MIB Locator found at the following URL: http://www.cisco.com/go/mibs

RFCs

RFCs	Title
RFC 2516	A Method for Transmitting PPP over Ethernet (PPPoE), February 1999

Technical Assistance

Description	Link
<p>The Cisco Support website provides extensive online resources, including documentation and tools for troubleshooting and resolving technical issues with Cisco products and technologies.</p> <p>To receive security and technical information about your products, you can subscribe to various services, such as the Product Alert Tool (accessed from Field Notices), the Cisco Technical Services Newsletter, and Really Simple Syndication (RSS) Feeds.</p> <p>Access to most tools on the Cisco Support website requires a Cisco.com user ID and password.</p>	<p>http://www.cisco.com/cisco/web/support/index.html</p>

Feature Information for PPPoE Service Selection

The following table provides release information about the feature or features described in this module. This table lists only the software release that introduced support for a given feature in a given software release train. Unless noted otherwise, subsequent releases of that software release train also support that feature.

Use Cisco Feature Navigator to find information about platform support and Cisco software image support. To access Cisco Feature Navigator, go to www.cisco.com/go/cfn. An account on Cisco.com is not required.

Table 48: Feature Information for PPPoE Service Selection

Feature Name	Releases	Feature Configuration Information
<p>PPPoE Service Selection</p>	<p>Cisco IOS XE Release 2.1</p>	<p>The PPPoE Service Selection feature uses service tags to enable a PPP over Ethernet (PPPoE) server to offer PPPoE clients a selection of services during call setup. You choose one of the services offered, and the service is provided when the PPPoE session becomes active.</p> <p>The following commands were introduced or modified: service profile, pppoe service, virtual-template.</p>



CHAPTER 37

Disabling AC-name and AC-cookie Tags from PPPoE PADS

The AC-name and AC-cookie Tags from PPP over Ethernet (PPPoE) Active Directory Session (PADS) feature prevents a device from sending the access concentrator (AC) information in the PADS packet.

- [Finding Feature Information, page 457](#)
- [Restrictions for Disabling AC-name and AC-cookie Tags from PPPoE PADS, page 457](#)
- [Information About Disabling AC-name and AC-cookie Tags from PPPoE PADS, page 458](#)
- [How to Disable AC-name and AC-cookie Tags from PPPoE PADS, page 458](#)
- [Configuration Example for Disabling AC-name and AC-cookie Tags from PPPoE PADS, page 460](#)
- [Additional References for Disabling AC-name and AC-cookie Tags from PPPoE PADS, page 460](#)
- [Feature Information for Disabling AC-name and AC-cookie Tags from PPPoE PADS, page 461](#)

Finding Feature Information

Your software release may not support all the features documented in this module. For the latest caveats and feature information, see [Bug Search Tool](#) and the release notes for your platform and software release. To find information about the features documented in this module, and to see a list of the releases in which each feature is supported, see the feature information table.

Use Cisco Feature Navigator to find information about platform support and Cisco software image support. To access Cisco Feature Navigator, go to www.cisco.com/go/cfn. An account on Cisco.com is not required.

Restrictions for Disabling AC-name and AC-cookie Tags from PPPoE PADS

- The AC-name and AC-cookie Tags from PPPoE PADS feature is available only on ASR and UNIX platforms.

- The AC-name and AC-cookie Tags from PPPoE PADS feature is supported only if the PPPoE Server functionality is supported.

Information About Disabling AC-name and AC-cookie Tags from PPPoE PADS

In the Broadband Access (BBA) environment, PPPoE Active Discovery Offer (PADO) sent from the Broadband Remote Access Server (BRAS) includes the AC-cookie tags (0x0104) and the AC-name tag (0x0102) along with a service-name tag identical to the one in the PPPoE Active Directory Initiation (PADI) and any number of other service-name tags indicating other services that access concentrator (AC) offers.

The AC-name is a string that uniquely identifies the particular AC. The AC-cookie tags are used by the AC to protect the denial-of-service (DoS) attacks.

The PPPoE Active Directory Request (PADR) from the Customer Premise Equipment (CPE) host also includes AC-name and AC-cookie tags received in PADO. BRAS repeats the AC information in the PPPoE Active Discovery Session-Confirmation (PADS) packet sent in response to PADR received from client (CPE).

When BRAS generates a unique session identifier for the PPPoE session, the AC-name and AC-cookie tags need not be sent in the PADS. This feature prevents sending the AC information in the device.

How to Disable AC-name and AC-cookie Tags from PPPoE PADS

Disabling AC-name and AC-cookie Tags from PPPoE PADS

SUMMARY STEPS

1. `enable`
2. `configure terminal`
3. `pppoe pads disable-ac-info`
4. `end`

DETAILED STEPS

	Command or Action	Purpose
Step 1	<code>enable</code> Example: Device> <code>enable</code>	Enables privileged EXEC mode. <ul style="list-style-type: none"> • Enter your password if prompted.

	Command or Action	Purpose
Step 2	configure terminal Example: Device# configure terminal	Enters global configuration mode.
Step 3	pppoe pads disable-ac-info Example: Device(config)# pppoe pads disable-ac-info	Defines a PPP over Ethernet (PPPoE) profile, and prevents the device from sending the AC-name and AC-cookie tags in the PADS packet.
Step 4	end Example: Device(config)# end	Exits global configuration mode and returns to privileged EXEC mode.

Verifying Disabling AC-name and AC-cookie Tags from PPPoE PADS

You can verify the Disabling AC-name and AC-cookie Tags from PPPoE PADS feature by enabling the **debug pppoe tag** command.

```

Device> enable
Device# debug pppoe tag
*Sep 6 07:46:25.352: PPPoE 0: I PADI R:aabb.cc00.6401 L:ffff.ffff.ffff Et1/0
*Sep 6 07:46:25.352: Service tag: NULL Tag
*Sep 6 07:46:25.352: PPPoE 0: O PADO, R:aabb.cc00.6501 L:aabb.cc00.6401 Et1/0
*Sep 6 07:46:25.352: Service tag: NULL Tag
*Sep 6 07:46:25.353: PPPoE 0: I PADR R:aabb.cc00.6401 L:aabb.cc00.6501 Et1/0
*Sep 6 07:46:25.353: Service tag: NULL Tag
*Sep 6 07:46:25.353: PPPoE : encaps string prepared
*Sep 6 07:46:25.353: [2]PPPoE 2: Access IE handle allocated
*Sep 6 07:46:25.353: [2]PPPoE 2: AAA get retrieved attrs
*Sep 6 07:46:25.353: [2]PPPoE 2: AAA get nas port details
*Sep 6 07:46:25.353: [2]PPPoE 2: AAA get dynamic attrs
*Sep 6 07:46:25.353: [2]PPPoE 2: AAA unique ID D allocated
*Sep 6 07:46:25.353: [2]PPPoE 2: No AAA accounting method list
*Sep 6 07:46:25.353: [2]PPPoE 2: Service request sent to SSS
*Sep 6 07:46:25.354: [2]PPPoE 2: Created, Service: None R:aabb.cc00.6501 L:aabb.cc00.6401
Et1/0
*Sep 6 07:46:25.354: [2]PPPoE 2: State NAS_PORT_POLICY_INQUIRY Event SSS MORE KEYS
*Sep 6 07:46:25.354: [2]PPPoE 2: data path set to PPP
*Sep 6 07:46:25.354: [2]PPPoE 2: Segment (SSS class): PROVISION
*Sep 6 07:46:25.354: [2]PPPoE 2: State PROVISION_PPP Event SSM PROVISIONED
*Sep 6 07:46:25.354: [2]PPPoE 2: Disable AC info from PADS
*Sep 6 07:46:25.354: [2]PPPoE 2: O PADS R:aabb.cc00.6401 L:aabb.cc00.6501 Et1/0

```

Configuration Example for Disabling AC-name and AC-cookie Tags from PPPoE PADS

Example: Disabling AC-name and AC-cookie Tags from PPPoE PADS

```
Device> enable
Device# configure terminal
Device(config)# pppoe pads disable-ac-info
Device(config)# end
```

Additional References for Disabling AC-name and AC-cookie Tags from PPPoE PADS

Related Documents

Related Topic	Document Title
Cisco IOS commands	Cisco IOS Master Command List, All Releases

Technical Assistance

Description	Link
<p>The Cisco Support website provides extensive online resources, including documentation and tools for troubleshooting and resolving technical issues with Cisco products and technologies.</p> <p>To receive security and technical information about your products, you can subscribe to various services, such as the Product Alert Tool (accessed from Field Notices), the Cisco Technical Services Newsletter, and Really Simple Syndication (RSS) Feeds.</p> <p>Access to most tools on the Cisco Support website requires a Cisco.com user ID and password.</p>	http://www.cisco.com/support

Feature Information for Disabling AC-name and AC-cookie Tags from PPPoE PADS

The following table provides release information about the feature or features described in this module. This table lists only the software release that introduced support for a given feature in a given software release train. Unless noted otherwise, subsequent releases of that software release train also support that feature.

Use Cisco Feature Navigator to find information about platform support and Cisco software image support. To access Cisco Feature Navigator, go to www.cisco.com/go/cfn. An account on Cisco.com is not required.

Table 49: Feature Information for Disabling AC-name and AC-cookie Tags from PPPoE PADS

Feature Name	Releases	Feature Information
AC-name and AC-cookie knob for PPPoE PADS	Cisco IOS XE Release 3.12S	This feature prevents a device from sending access concentrator information in the PADS packet. The following commands were introduced or modified: pppoe pads disable-ac-info .



Broadband Smart Licensing

The Broadband Smart Licensing feature supports broadband Lite sessions during the deployment of ASR1000 Aggregation Services Routers.

- [Finding Feature Information, page 463](#)
- [Prerequisites for Broadband Smart Licensing, page 463](#)
- [Restrictions for Broadband Smart Licensing, page 464](#)
- [Information About Broadband Smart Licensing, page 464](#)
- [How to Configure Broadband Smart Licensing, page 464](#)
- [Configuration Examples for Broadband Smart Licensing, page 466](#)
- [Additional References for Broadband Smart Licensing, page 467](#)
- [Feature Information for Broadband Smart Licensing, page 468](#)

Finding Feature Information

Your software release may not support all the features documented in this module. For the latest caveats and feature information, see [Bug Search Tool](#) and the release notes for your platform and software release. To find information about the features documented in this module, and to see a list of the releases in which each feature is supported, see the feature information table.

Use Cisco Feature Navigator to find information about platform support and Cisco software image support. To access Cisco Feature Navigator, go to www.cisco.com/go/cfn. An account on Cisco.com is not required.

Prerequisites for Broadband Smart Licensing

.

Restrictions for Broadband Smart Licensing

- The Broadband Smart Licensing feature is supported only on AR1K running Polaris 16.5 release and above.
- The feature does not support broadband Lite sessions.
- The stand-by RP does not have an account.
- Only broadband smart licenses that are multiples of two can be requested, 1 license = 2 thousand sessions.

Information About Broadband Smart Licensing

Broadband Sessions

How to Configure Broadband Smart Licensing

Configuring the Subscriber License

To configure broadband smart licensing, configure the **subscriber license** command before starting a broadband session.

Before You Begin

Do the following:

SUMMARY STEPS

1. **enable**
2. **configure terminal**
3. **subscriber license**
4. **exit**

DETAILED STEPS

	Command or Action	Purpose
Step 1	enable Example: Device> enable	<ul style="list-style-type: none"> • Enables privileged EXEC mode. • Enter your password if prompted.

	Command or Action	Purpose
Step 2	configure terminal Example: Device# configure terminal	Enters global configuration mode.
Step 3	subscriber license Example: Device(config)# subscriber license	Configures the subscriber license. Note The following configurations are essential to establish a connection between the ASR1000 and the licensing server. <ul style="list-style-type: none"> • License Smart Enable • Call Home • Device Registration
Step 4	exit Example: Device(config)# exit	Exits global configuration mode. Note If the subscriber license command is configured before bringing up a broadband session, irrespective of any earlier broadband license request failure, the range of the license to be requested must be between 2 – 128K (range of subscriber license). When the session count exceeds the procured broadband license count by 100, a request is sent for a new license. Ensure that there is no failure of license procurement in the last 24 hours. Note Use the subscriber license command to release all procured licenses. During procuring and releasing the licenses, a message is displayed with the details about the license and the session count.

Clearing the Subscriber License

SUMMARY STEPS

1. clear subscriber license

DETAILED STEPS

	Command or Action	Purpose
Step 1	clear subscriber license Example: Device# clear subscriber license *Jul 10 10:24:27.217: %SSSMGR-5-BB_LICENSE_REQUEST_SENT: Broadband license request sent for 0 license with configured license count 0 *Jul 10 10:24:27.217: %SSSMGR-5-BB_LICENSE_RELEASE_SUCCESS: Successfully released all BroadBand licenses	

	Command or Action	Purpose
	Sessions: ISG session, except for the lite session	

Verifying Broadband Smart Licensing

SUMMARY STEPS

1. Debug subscriber license

DETAILED STEPS

Debug subscriber license

Configuration Examples for Broadband Smart Licensing

Example: show subscriber license

The **show subscriber license** command tracks the number of procured broadband licenses, the configured value of broadband licenses, current session count on the router, the highest session count reached since the last license request was sent to the server and the time at which it was procured.

The following is sample output of the **show subscriber license** command

```
Device# show subscriber license
Broadband Smart License Compliance           : In Compliance

Total Number of Broadband Licenses Procured : 0

Broadband Licenses Configured               : 0

Current Broadband Session Count             : 0

Time of Last License Procurement            : No License Procured

Sessions Peak Count Since Last Procurement  : 0
```

Use the **no subscriber license** command to release all procured licenses.

no subscriber license**Note**

During procuring and releasing of licenses, a message is displayed with the license details and the session count.

Example: Show license summary

Example: Show license summary

Example: Clear subscriber license

Example: Clear subscriber license

Additional References for Broadband Smart Licensing

Related Documents

Related Topic	Document Title
Cisco IOS commands	Cisco IOS Master Commands List, All Releases

Standards and RFCs

Standard/RFC	Title
Standard	<i>Title</i>

MIBs

MIB	MIBs Link
• CISCO-MIB	To locate and download MIBs for selected platforms, Cisco IOS releases, and feature sets, use Cisco MIB Locator found at the following URL: http://www.cisco.com/go/mibs

Technical Assistance

Description	Link
<p>The Cisco Support website provides extensive online resources, including documentation and tools for troubleshooting and resolving technical issues with Cisco products and technologies.</p> <p>To receive security and technical information about your products, you can subscribe to various services, such as the Product Alert Tool (accessed from Field Notices), the Cisco Technical Services Newsletter, and Really Simple Syndication (RSS) Feeds.</p> <p>Access to most tools on the Cisco Support website requires a Cisco.com user ID and password.</p>	<p>http://www.cisco.com/cisco/web/support/index.html</p>

Feature Information for Broadband Smart Licensing

The following table provides release information about the feature or features described in this module. This table lists only the software release that introduced support for a given feature in a given software release train. Unless noted otherwise, subsequent releases of that software release train also support that feature.

Use Cisco Feature Navigator to find information about platform support and Cisco software image support. To access Cisco Feature Navigator, go to www.cisco.com/go/cfn. An account on Cisco.com is not required.

Table 50: Feature Information for Broadband Smart Licensing

Feature Name	Releases	Feature Information
Broadband Smart Licensing	Cisco IOS XE Everest 16.6.1	<p>The Broadband Smart Licensing feature enables to purchase licenses for any number of broadband sessions that are active during the deployment of ASR1000 Aggregation Services Routers.</p> <p>The following commands were introduced or modified:subscriber license, show subscriber licens</p>