



IEEE 802.1ah on Provider Backbone Bridges

The IEEE 802.1ah on Provider Backbone Bridges feature enables MAC-in-MAC tunneling on Ethernet virtual circuits (EVCs).

- [Finding Feature Information, page 1](#)
- [Prerequisites for IEEE 802.1ah on Provider Backbone Bridges, page 1](#)
- [Restrictions for IEEE 802.1ah on Provider Backbone Bridges, page 2](#)
- [Information About IEEE 802.1ah on Provider Backbone Bridges, page 2](#)
- [How to Configure MAC-in-MAC on Provider Backbone Bridges, page 7](#)
- [Configuration Examples for MAC-in-MAC on Provider Backbone Bridges, page 20](#)
- [Additional References, page 22](#)
- [Feature Information for IEEE 802.1ah on Provider Backbone Bridges, page 23](#)

Finding Feature Information

Your software release may not support all the features documented in this module. For the latest caveats and feature information, see [Bug Search Tool](#) and the release notes for your platform and software release. To find information about the features documented in this module, and to see a list of the releases in which each feature is supported, see the feature information table at the end of this module.

Use Cisco Feature Navigator to find information about platform support and Cisco software image support. To access Cisco Feature Navigator, go to www.cisco.com/go/cfn. An account on Cisco.com is not required.

Prerequisites for IEEE 802.1ah on Provider Backbone Bridges

- The router configuration must include an ES40 line card, because the Institute of Electrical and Electronic Engineers (IEEE) 802.1ah standard is supported on ES40 line cards only.
- IEEE 802.1ah is supported on EVC architecture only.

Restrictions for IEEE 802.1ah on Provider Backbone Bridges

- The following features are not supported:
 - Connectivity Fault Management (CFM) over 802.1ah
 - Internet Group Multicast Protocol (IGMP) snooping or any multicast protocol on the customer-bridge (c-bridge) domain
 - Standalone customer-facing backbone edge bridge (I-BEB)
 - Standalone backbone core bridge-facing backbone edge bridge (B-BEB)
- The following limits apply to this feature:
 - Maximum number of MAC tunnels is 4094.
 - Maximum number of service instances under MAC tunnels is 16,384.
 - Maximum number of Ethernet Flow Points (EFP) is 32,768.
 - Maximum number of EFPs on a single interface is 8000.
 - 802.1ah on the port channel is supported for one member link per port channel only.

Information About IEEE 802.1ah on Provider Backbone Bridges

MAC-in-MAC

The IEEE 802.1ah on Provider Backbone Bridges feature encapsulates the end users traffic inside the service providers MAC header, enabling the backbone edge bridge (BEB) to support large numbers of service instances. This functionality is also known as MAC-in-MAC or MAC Tunneling Protocol (MTP). It also allows service providers to hide the identity of their equipment vendors by using user-specified MAC address as the tunnel source address. It also separates the user MAC address space from the provider MAC address space which means that only the edge bridges are aware of the customer MAC addresses, and that only the core bridges are aware of the provider addresses.

The figure below shows a typical 802.1ah PBB network and the table below describes the PBB network components.

Table 1: IEEE 802.1ah PBB Components

Component	Description
BCB	Backbone core bridge
BEB	Backbone edge bridge
CE	Customer equipment

Component	Description
PB	Provider bridge
PEB	Provider edge bridge

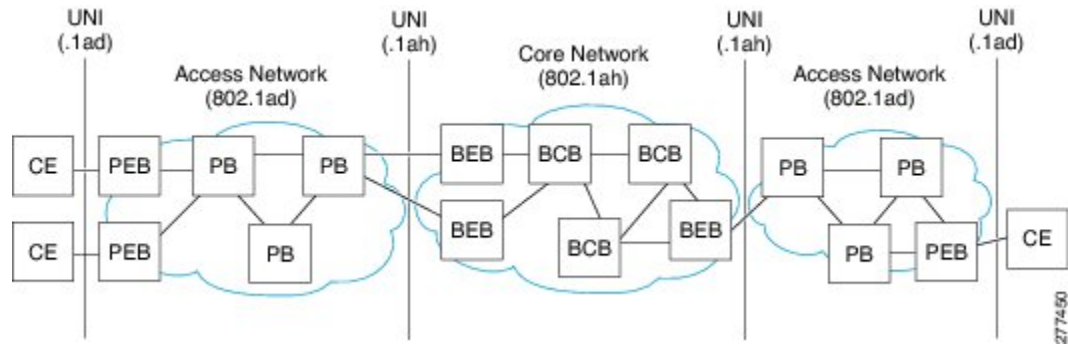

Backbone Edge Bridges

BEBs can contain either an I-Component or a B-Component. The I-Component maps Service VLAN identifiers (S-VIDs) to service instance identifiers (I-SIDs) and adds a PBB header without a B-Tag. The B-Component maps I-SIDs to backbone VLANs (B-VIDs) and adds a PBB header with a B-Tag. The IEEE 802.1ah standard specifies the following three types of BEBs:

- The B-Bridge (B-BEB) contains the B-Component of the MAC-in-MAC bridge. It validates the I-SIDs and maps the frames onto the backbone VLAN (B-VLAN). It also switches traffic based on the B-VLANs within the core bridge.
- The I-Bridge (I-BEB) contains the I-Component of the MAC-in-MAC bridge. It performs B-MAC encapsulation and inserts the I-SIDs based on the S-tags, C-tags, or S-tag/C-tag pairs.
- The IB-Bridge (IB-BEB) contains one or more I-Components and a single B-Component interconnected via a LAN segment.



Note

The Cisco 7600 series routers are designed to work as IB-Bridges.

IB-Bridges

The IB-Bridge contains both the I-Component and the B-Component. The bridge selects the B-MAC and inserts the I-SID based on the provider VLAN tag (S-tag), the customer VLAN tag (C-tag), or both the S-tag and the C-tag. It validates the I-SIDs and it transmits and receives frames on the B-VLAN.

The IB-Bridge has two types of interfaces:

- Port-based interface: On port-based interfaces all S-tagged frames received from a customer are mapped to an I-SID and the S-tags are preserved.

- S-tagged interface: S-tagged interfaces support one-to-one mapping of an S-VLAN to an I-SID to provide S-VLAN translation capabilities. They also support many-to-one mapping of S-VLANs to an I-SID to provide S-VLAN bundling capability.

The IEEE 802.1ah on Provider Backbone Bridges feature supports all services mandated by the IEEE 802.1ah standard and extends the services to provide additional functionality as follows:

- S-Tagged Service:
 - In multiplexed environments each S-tag maps to an I-SID and may be retained or removed.
 - In bundled environments multiple S-tags map to the same I-SID and the S-tags must be retained.
- C-Tagged Service:
 - In multiplexed environments each C-tag maps to an I-SID and may be retained or removed.
 - In bundled environments multiple C-tags map to the same I-SID and the C-tags must be retained.
- S/C-Tagged Service:
 - In multiplexed environments each S-tag/C-tag pair maps to an I-SID. The S-tag or the S-tag/C-tag pair may be retained or removed.
 - In bundled environments multiple S-tag/C-tags pairs map to the same I-SID and the S-tag/C-tag pair must be retained.
- Port-based Service
 - Any frame whether untagged or double tagged is mapped to the same I-SID and all tags are retained.

IEEE 802.1ah for L2 Bridging Networks

When IEEE 802.1ah is configured on PBBs in an L2 bridging network the packets on the ingress EFP are tunneled to the appropriate MAC tunnel using the bridging identifier in the I-Component (specified using the **bridge-domain c-mac** command). If multiple EFPs use the same I-SID then the C-MAC bridge domain also performs the switching between the EFPs.

The figure below shows a typical L2 bridging network configuration.

Figure 1: IEEE 802.1ah L2 Bridging Network

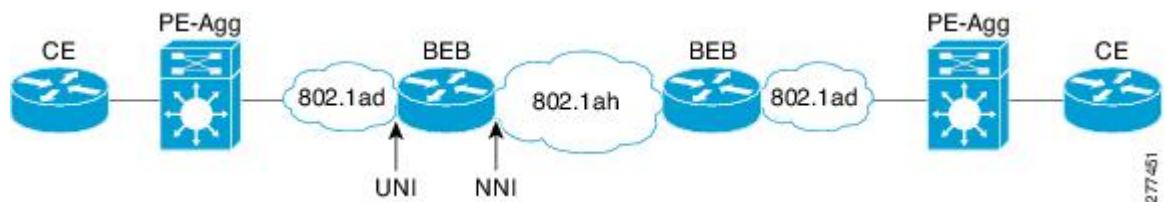

The table below describes the components of the L2 bridging network.

Table 2: L2 Bridging Network Components

Component Name	Description
802.1ad	IEEE 802.1ad (provider bridges) network
802.1ah	IEEE 802.1ah (provider backbone bridge) network
BEB	Backbone edge bridge
CE	Customer equipment
NNI	Network-to-network interface (egress EFP)
PE-Agg	Provider edge aggregation device
UNI	User-Network Interface (ingress EFP)

Unknown Unicast and Customer Multicast Traffic

The figure below shows an L2 network where all the BEBs are connected to each other through a single Backbone VLAN (B-VLAN). In this scenario any unknown unicast traffic from BEB1 is forwarded to BEB2 through to BEB5 because they all share the same B-VLAN.

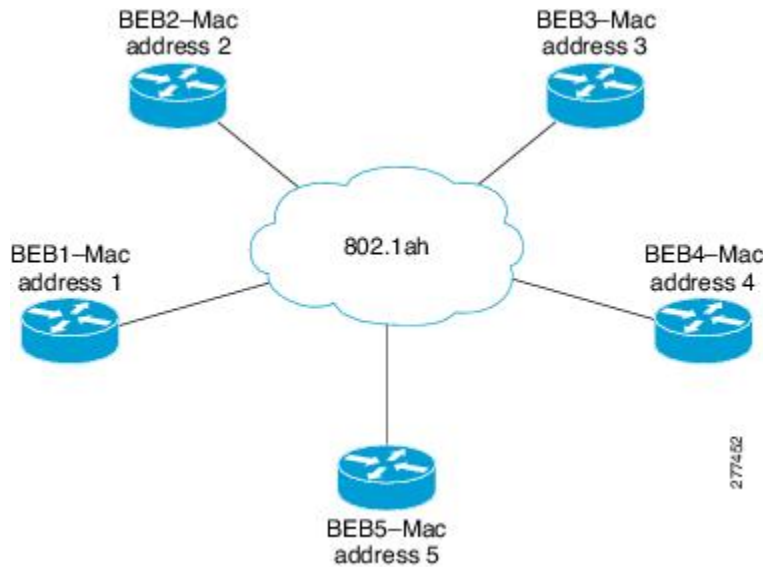
Figure 2: BEB B-VLAN Network

In order to reduce network traffic you can configure a BEB to send traffic to specific BEBs on the B-VLAN. For example, if BEB1 needs to send traffic to BEB3 and BEB4 only, you can use the **mac tunnel address destination map** command to map the customer destination address (C-DA) to a multicast backbone destination address (B-DA). BEB3 and BEB4 are then registered to receive traffic for this B-DA.

All packets within the 802.1ah network must be sent to a specified MAC address. The address is a static entry in the MAC address tables in the backbone core bridges. If a default MAC tunnel address is not specified in the table, then all unknown unicast packets and customer multicast traffic are sent with the default B-DA, which is a combination of IEEE-assigned Organizational Unique Identifier (OUI) and the I-SID values.

IEEE 802.1ah for Ethernet Over MPLS

When IEEE 802.1ah is configured on Ethernet over Multiprotocol Label Switching (EoMPLS) networks, the Ethernet links are transported as pseudowires using MPLS label switched paths (LSPs) inside an MPLS tunnel. To configure MAC-in-MAC on EoMPLS networks you must specify ingress EFP configuration settings at the UNI, specify MAC-in-MAC settings, and specify switch virtual interface (SVI) configuration settings at the egress NNI. The SVI represents a VLAN of switch ports connected to the bridge via a single interface.

The figure below shows a typical EoMPLS network configuration.

Figure 3: IEEE 802.1ah EoMPLS Network

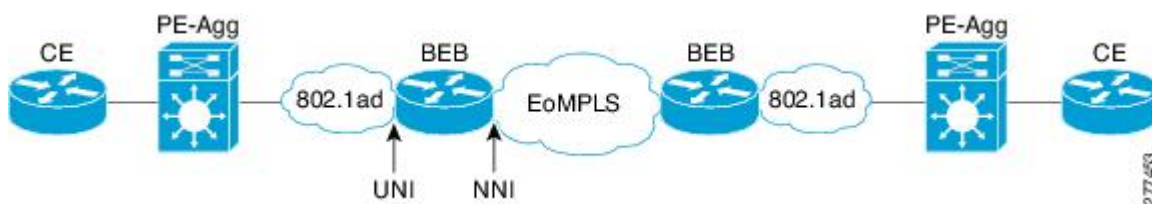

Note

In EoMPLS networks Cisco 7600 series routers use the bridge domain identifier (set using the **bridge-domain** command) as the B-tag identifier. Therefore it is not necessary to specify B-VLAN configuration for the MAC-in-MAC tunnel.

IEEE 802.1ah for Virtual Private LAN Services

When IEEE 802.1ah is configured on virtual private LAN service (VPLS) networks the 802.1ah packets are encapsulated in the VPLS pseudowire.

To configure MAC-in-MAC on VPLS networks you must specify the ingress EFP configuration settings at the UNI, specify the MAC-in-MAC settings, specify the virtual forwarding interface (VFI) settings, and specify the SVI configuration settings at the egress NNI. The SVI represents a VLAN of switch ports connected to the bridge via a single interface.

The figure below shows two 802.1ah networks connected by VPLS.

Figure 4: IEEE 802.1ah VPLS Network

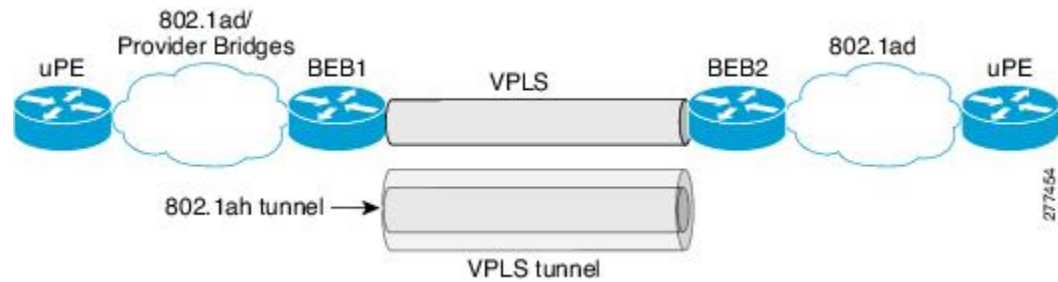

How to Configure MAC-in-MAC on Provider Backbone Bridges

Configuring MAC-in-MAC in an L2 Bridging Network

Perform this task to configure MAC-in-MAC in an L2 bridging network where the NNI has a switchport-based configuration.

SUMMARY STEPS

1. **enable**
2. **configure terminal**
3. **interface gigabitethernet *slot / port***
4. **service instance *id* ethernet**
5. **encapsulation dot1q *vlan-id***
6. **bridge-domain *bridge-id* c-mac**
7. **exit**
8. **exit**
9. **ethernet mac-tunnel virtual *tunnel-id***
10. **description *description***
11. **bridge-domain *bridge-id***
12. **mac tunnel address destination default *mac-addr***
13. **service instance *id* ethernet**
14. **encapsulation dot1ah isid *isid***
15. **mac tunnel address destination map *c-mac-addr b-mac-addr***
16. **bridge-domain *bridge-id* c-mac**
17. **exit**
18. **exit**
19. **interface gigabitethernet *slot / port***
20. **switchport**
21. **switchport mode trunk**
22. **switchport trunk allowed vlan *vlan-id***
23. **end**
24. **show bridge-domain**
25. **show ethernet mac-tunnel engine slot *slot-number***
26. **show ethernet service instance**
27. **show ethernet service mac-tunnel**

DETAILED STEPS

	Command or Action	Purpose
Step 1	enable Example: Router> enable	Enables privileged EXEC mode. <ul style="list-style-type: none"> • Enter your password if prompted.

	Command or Action	Purpose
Step 2	configure terminal Example: Router# configure terminal	Enters global configuration mode.
Step 3	interface gigabitethernet slot / port Example: Router(config)# interface gigabitethernet 6/1	Specifies the Gigabit Ethernet interface to configure as the customer instance port and enters interface configuration mode.
Step 4	service instance id ethernet Example: Router(config-if)# service instance 101 ethernet	Creates an L2 service instance on an interface and enters service instance configuration mode.
Step 5	encapsulation dot1q vlan-id Example: Router(config-if-srv)# encapsulation dot1q 13	Defines the matching criteria to be used in order to map ingress dot1q frames on an interface to the appropriate service instance.
Step 6	bridge-domain bridge-id c-mac Example: Router(config-if-srv)# bridge-domain 12 c-mac	Specifies the bridging identifier in the I-Component.
Step 7	exit Example: Router(config-if-srv)# exit	Exits service instance configuration mode.
Step 8	exit Example: Router(config-if)# exit	Exits service interface configuration mode.
Step 9	ethernet mac-tunnel virtual tunnel-id Example: Router(config)# ethernet mac-tunnel virtual 1	Configures a virtual MAC-in-MAC tunnel and enters MAC-in-MAC tunnel configuration mode.

	Command or Action	Purpose
Step 10	description <i>description</i> Example: <pre>Router(config-tunnel-minm)# description MAC-Tunnel-1</pre>	(Optional) Describes the name and purpose of the MAC tunnel.
Step 11	bridge-domain <i>bridge-id</i> Example: <pre>Router(config-tunnel-minm)# bridge-domain 100</pre>	Binds the MAC tunnel to the bridge domain instance.
Step 12	mac tunnel address destination default <i>mac-addr</i> Example: <pre>Router(config-tunnel-minm)# mac tunnel address destination default 4444.1111.1111</pre>	Specifies a B-DA for a group of service instance IDs (I-SIDs).
Step 13	service instance <i>id</i> ethernet Example: <pre>Router(config-tunnel-minm)# service instance 10 ethernet</pre>	Defines an EFP that corresponds to a specific I-SID encapsulation and enters tunnel service configuration mode.
Step 14	encapsulation dot1ah isid <i>isid</i> Example: <pre>Router(config-tunnel-srv)# encapsulation dot1ah isid 10000</pre>	Configures dot1ah encapsulation for the specified I-SID.
Step 15	mac tunnel address destination map <i>c-mac-addr</i> <i>b-mac-addr</i> Example: <pre>Router(config-tunnel-srv)# mac tunnel address destination map 3333.1111.1111 5555.2222.2222</pre>	Maps the service provider backbone bridge MAC address to a customer MAC address.
Step 16	bridge-domain <i>bridge-id</i> c-mac Example: <pre>Router(config-tunnel-srv)# bridge-domain 30 c-mac</pre>	Configures the bridge domain as a customer domain.
Step 17	exit Example: <pre>Router(config-tunnel-srv)# exit</pre>	Exits tunnel service configuration mode.

	Command or Action	Purpose
Step 18	exit Example: <pre>Router(config-tunnel-minm)# exit</pre>	Exits MAC-in-MAC tunnel configuration mode.
Step 19	interface gigabitethernet slot / port Example: <pre>Router(config)# interface gigabitethernet 6/2</pre>	Specifies the Gigabit Ethernet interface to configure as the bridge instance port and enters interface configuration mode.
Step 20	switchport Example: <pre>Router(config-if)# switchport</pre>	Modifies the switching characteristics of the L2 switched interface.
Step 21	switchport mode trunk Example: <pre>Router(config-if)# switchport mode trunk</pre>	Specifies a trunking VLAN L2 interface.
Step 22	switchport trunk allowed vlan vlan-id Example: <pre>Router(config-if)# switchport trunk allowed vlan 100</pre>	Sets the list of allowed VLANs that transmit traffic from this interface in tagged format when in trunking mode.
Step 23	end Example: <pre>Router(config-if)# end</pre>	Exits interface configuration mode and enables user EXEC mode.
Step 24	show bridge-domain Example: <pre>Router> show bridge-domain</pre>	(Optional) Displays bridge-domain information.
Step 25	show ethernet mac-tunnel engine slot slot-number Example: <pre>Router> show ethernet mac-tunnel engine slot 2</pre>	(Optional) Displays Ethernet MAC-in-MAC information.

	Command or Action	Purpose
Step 26	show ethernet service instance Example: Router> show ethernet service instance	(Optional) Displays Ethernet service instance information.
Step 27	show ethernet service mac-tunnel Example: Router> show ethernet service mac-tunnel	(Optional) Displays Ethernet service MAC-in-MAC information.

Configuring MAC-in-MAC in an Ethernet over MPLS Network

Perform this task to configure MAC-in-MAC in an EoMPLS network.

SUMMARY STEPS

1. **enable**
2. **configure terminal**
3. **interface gigabitethernet slot / port**
4. **service instance id ethernet**
5. **encapsulation dot1q vlan-id**
6. **bridge-domain bridge-id c-mac**
7. **exit**
8. **exit**
9. **ethernet mac-tunnel virtual tunnel-id**
10. **bridge-domain bridge-id**
11. **service instance id ethernet**
12. **encapsulation dot1ah isid isid**
13. **bridge-domain bridge-id c-mac**
14. **exit**
15. **exit**
16. **interface vlan vlanid**
17. **xconnect ipaddress vc-id encapsulation mpls**
18. **exit**

DETAILED STEPS

	Command or Action	Purpose
Step 1	enable Example: Router> enable	Enables privileged EXEC mode. <ul style="list-style-type: none"> • Enter your password if prompted.
Step 2	configure terminal Example: Router# configure terminal	Enters global configuration mode.
Step 3	interface gigabitethernet slot / port Example: Router(config)# interface gigabitethernet 6/1	Specifies the Gigabit Ethernet interface to configure as the customer instance port and enters interface configuration mode.
Step 4	service instance id ethernet Example: Router(config-if)# service instance 101 ethernet	Creates an L2 service instance on an interface and enters service instance configuration mode.
Step 5	encapsulation dot1q vlan-id Example: Router(config-if-srv)# encapsulation dot1q 13	Defines the matching criteria to be used in order to map ingress dot1q frames on an interface to the appropriate service instance.
Step 6	bridge-domain bridge-id c-mac Example: Router(config-if-srv)# bridge-domain 12 c-mac	Specifies the bridging identifier in the I-Component.
Step 7	exit Example: Router(config-if-srv)# exit	Exits service instance configuration mode.
Step 8	exit Example: Router(config-if)# exit	Exits interface configuration mode.

	Command or Action	Purpose
Step 9	ethernet mac-tunnel virtual <i>tunnel-id</i> Example: <pre>Router(config)# ethernet mac-tunnel virtual 1</pre>	Configures a virtual MAC-in-MAC tunnel and enters MAC-in-MAC tunnel configuration mode.
Step 10	bridge-domain <i>bridge-id</i> Example: <pre>Router(config-tunnel-minm)# bridge-domain 100</pre>	Binds the MAC tunnel to the bridge domain instance.
Step 11	service instance <i>id</i> ethernet Example: <pre>Router(config-tunnel-minm)# service instance 10 ethernet</pre>	Defines an EFP that corresponds to a specific I-SID encapsulation and enters tunnel service configuration mode.
Step 12	encapsulation dot1ah isid <i>isid</i> Example: <pre>Router(config-tunnel-srv)# encapsulation dot1ah isid 10000</pre>	Configures dot1ah encapsulation for the specified I-SID.
Step 13	bridge-domain <i>bridge-id</i> c-mac Example: <pre>Router(config-tunnel-srv)# bridge-domain 30 c-mac</pre>	Configures the bridge domain as a customer domain.
Step 14	exit Example: <pre>Router(config-tunnel-srv)# exit</pre>	Exits tunnel service configuration mode.
Step 15	exit Example: <pre>Router(config-tunnel-minm)# exit</pre>	Exits MAC-in-MAC tunnel configuration mode.
Step 16	interface vlan <i>vlanid</i> Example: <pre>Router(config)# interface vlan 1000</pre>	Creates a dynamic SVI, and enters interface configuration mode.

	Command or Action	Purpose
Step 17	<p>xconnect <i>ipaddress vc-id encapsulation mpls</i></p> <p>Example:</p> <pre>Router(config-if)# xconnect 10.243.245.11 100 encapsulation mpls</pre>	<p>Binds the attachment circuit to the pseudowire, and configures an Any Transport over MPLS (AToM) static pseudowire.</p> <ul style="list-style-type: none"> • Specifies MPLS as the tunneling method to encapsulate the data in the pseudowire.
Step 18	<p>exit</p> <p>Example:</p> <pre>Router(config-if)# exit</pre>	<p>Returns to global configuration mode.</p>

Configuring MAC-in-MAC in a VPLS Network

Perform this task to configure MAC-in-MAC in a VPLS network. The following configuration enables the router to work as an IB-Bridge.



Note

On Cisco 7600 series routers the bridge-domain identifier must be the same as the SVI identifier.

SUMMARY STEPS

1. **enable**
2. **configure terminal**
3. **interface gigabitethernet *slot / port***
4. **service instance *id* ethernet**
5. **encapsulation dot1q *vlan-id***
6. **bridge-domain *bridge-id* c-mac**
7. **exit**
8. **exit**
9. **ethernet mac-tunnel virtual *tunnel-id***
10. **bridge-domain *bridge-id***
11. **service instance *id* ethernet**
12. **encapsulation dot1ah isid *isid***
13. **bridge-domain *bridge-id* c-mac**
14. **exit**
15. **service instance *id* ethernet**
16. **encapsulation dot1ah isid *isid***
17. **bridge-domain *bridge-id* c-mac**
18. **exit**
19. **exit**
20. **!2 vfi *vfi-name* manual**
21. **vpn id *vpn-id***
22. **neighbor *ipaddress* *vcid* encapsulation mpls**
23. **neighbor *ipaddress* *vcid* encapsulation mpls**
24. **exit**
25. **interface vlan *vlanid***
26. **xconnect *ipaddress* *vc-id* encapsulation mpls**
27. **exit**

DETAILED STEPS

	Command or Action	Purpose
Step 1	enable Example: Router> enable	Enables privileged EXEC mode. <ul style="list-style-type: none"> • Enter your password if prompted.

	Command or Action	Purpose
Step 2	configure terminal Example: Router# configure terminal	Enters global configuration mode.
Step 3	interface gigabitethernet slot / port Example: Router(config)# interface gigabitethernet 6/1	Specifies the Gigabit Ethernet interface to configure as the customer instance port and enters interface configuration mode.
Step 4	service instance id ethernet Example: Router(config-if)# service instance 101 ethernet	Creates an L2 service instance on an interface and enters service instance configuration mode.
Step 5	encapsulation dot1q vlan-id Example: Router(config-if-srv)# encapsulation dot1q 13	Defines the matching criteria to be used in order to map ingress dot1q frames on an interface to the appropriate service instance.
Step 6	bridge-domain bridge-id c-mac Example: Router(config-if-srv)# bridge-domain 12	Specifies the bridging identifier in the I-Component.
Step 7	exit Example: Router(config-if-srv)# exit	Exits service instance configuration mode.
Step 8	exit Example: Router(config-if)# exit	Exits interface configuration mode.
Step 9	ethernet mac-tunnel virtual tunnel-id Example: Router(config)# ethernet mac-tunnel virtual 1	Configures a virtual MAC-in-MAC tunnel and enters MAC-in-MAC tunnel configuration mode.

	Command or Action	Purpose
Step 10	bridge-domain <i>bridge-id</i> Example: Router(config-tunnel-minm)# bridge-domain 100	Binds the MAC tunnel to the bridge domain instance.
Step 11	service instance <i>id</i> ethernet Example: Router(config-tunnel-minm)# service instance 31 ethernet	Defines an EFP that corresponds to a specific I-SID encapsulation and enters tunnel service configuration mode.
Step 12	encapsulation dot1ah isid <i>isid</i> Example: Router(config-tunnel-srv)# encapsulation dot1ah isid 10000	Configures dot1ah encapsulation for the specified I-SID.
Step 13	bridge-domain <i>bridge-id</i> c-mac Example: Router(config-tunnel-srv)# bridge-domain 10 c-mac	Configures the bridge domain as a customer domain.
Step 14	exit Example: Router(config-tunnel-srv)# exit	Exits tunnel service configuration mode.
Step 15	service instance <i>id</i> ethernet Example: Router(config-tunnel-minm)# service instance 41 ethernet	Defines an EFP that corresponds to a specific I-SID encapsulation and enters tunnel service configuration mode.
Step 16	encapsulation dot1ah isid <i>isid</i> Example: Router(config-tunnel-srv)# encapsulation dot1ah isid 20000	Configures dot1ah encapsulation for the specified I-SID.
Step 17	bridge-domain <i>bridge-id</i> c-mac Example: Router(config-tunnel-srv)# bridge-domain 20 c-mac	Configures the bridge domain as a customer domain.

	Command or Action	Purpose
Step 18	exit Example: Router(config-tunnel-srv)# exit	Exits tunnel service configuration mode.
Step 19	exit Example: Router(config-tunnel-minm)# exit	Exits MAC-in-MAC tunnel configuration mode.
Step 20	l2 vfi vfi-name manual Example: Router(config)# l2 vfi myvfi manual	Configures a virtual forwarding instance and enters L2 VFI point-to-point configuration mode.
Step 21	vpn id vpn-id Example: Router(config-vfi)# vpn id 20	Sets a VPN ID on a VPN routing and forwarding (VRF) instance.
Step 22	neighbor ipaddress vcid encapsulation mpls Example: Router(config-vfi)# neighbor 172.16.10.12 2000 encapsulation mpls	Specifies the first router that forms a point-to-point Layer 2 VFI connection.
Step 23	neighbor ipaddress vcid encapsulation mpls Example: Router(config-vfi)# neighbor 172.16.200.120 2000 encapsulation mpls	Specifies the second router that forms a point-to-point Layer 2 VFI connection.
Step 24	exit Example: Router(config-vfi)# exit	Exits L2 VFI point-to-point configuration mode.
Step 25	interface vlan vlanid Example: Router(config)# interface vlan 1000	Creates a dynamic SVI, and enters interface configuration mode.

	Command or Action	Purpose
Step 26	xconnect <i>ipaddress</i> <i>vc-id</i> encapsulation mpls Example: Router(config-if)# xconnect 10.243.245.11 100 encapsulation mpls	Binds the attachment circuit to the pseudowire, and configures an AToM static pseudowire. <ul style="list-style-type: none"> Specifies MPLS as the tunneling method to encapsulate the data in the pseudowire.
Step 27	exit Example: Router(config-if)# exit	Returns to global configuration mode.

Configuration Examples for MAC-in-MAC on Provider Backbone Bridges

Example MAC-in-MAC Configuration for L2 Bridging Networks

In the following example, the UNI configuration is performed on the GigabitEthernet 1/0, GigabitEthernet 2/0, and GigabitEthernet 3/0 interfaces. The MAC-in-MAC tunnel configuration includes commands to configure the default MAC tunnel destination address and the destination map. The NNI configuration is performed on the GigabitEthernet 1/2 interface, and shows the options for a switchport or External Interface (EI)-based NNI.



Note

For switchport NNI configurations the VLAN ID is the same as the bridge domain ID configured under the MAC tunnel. For EI NNI configurations a service instance is configured under the NNI interface and the binding of the MAC tunnel to the service instance is done using the bridge domain.

UNI (Ingress) Configuration

```
interface gigabitethernet 1/0
service instance 10 ethernet
encapsulation dot1q 10
bridge-domain 20 c-mac
service instance 20 ethernet
encapsulation dot1q 20
bridge-domain 30 c-mac
interface gigabitethernet 2/0
service instance 10 ethernet
encapsulation dot1q 10
bridge-domain 20 c-mac
service instance 30 ethernet
encapsulation dot1q 20
bridge-domain 30 c-mac
```

```
interface gigabitethernet 3/0
 service instance 10 ethernet
 encapsulation dot1q 10
 bridge-domain 20 c-mac
```

MAC-in-MAC Tunnel Configuration

```
ethernet mac-tunnel virtual 1
 bridge-domain 100
 mac tunnel address destination default 4444.1111.1111
 service instance 10 ethernet
 encapsulation dot1ah isid 10000
 bridge-domain 20 c-mac
 service instance 20 ethernet
 encapsulation dot1ah isid 20000
 bridge-domain 30 c-mac
 mac tunnel address destination map 3333.1111.1111 5555.2222.2222
```

Switchport NNI (Egress) Configuration

```
interface gigabitethernet 1/2
 switchport
 switchport mode trunk
 switchport trunk allowed vlan 100
```

EI NNI (Egress) Configuration

```
interface gigabitethernet 1/2
 service instance 20 ethernet
 encapsulation dot1q
 bridge-domain 100
```

Example MAC-in-MAC Configuration for Ethernet over MPLS Networks

The following example shows how to configure a BEB where two 802.1ah networks are connected using MPLS:

UNI (Ingress) Configuration

```
interface gigabitethernet 1/1
 service instance 15 ethernet
 encapsulation dot1q 20
 bridge-domain 10 c-mac
```

MAC-in-MAC Tunnel Configuration

```
ethernet mac-tunnel virtual 1
 bridge-domain 1000
 service instance 500 ethernet
 encapsulation dot1ah isid 10000
 bridge-domain 10 c-mac
```

SVI Configuration

```
interface vlan 1000
 xconnect 10.243.245.11 100 encapsulation mpls
```

Example MAC-in-MAC Configuration for VPLS Networks

The following example shows how to configure a BEB where two 802.1ah networks are connected using VPLS. The 802.1ah packets are encapsulated in the VPLS pseudowire.

UNI (Ingress) Configuration

```
interface gigabitethernet 1/1
 service instance 21 ethernet
 encapsulation dot1q 20
 bridge-domain 10 c-mac
```

MAC-in-MAC Tunnel Configuration

```
ethernet mac-tunnel virtual 1
 bridge-domain 100
 service instance 31 ethernet
 encapsulation dot1ah isid 10000
 bridge-domain 10 c-mac
 service instance 41 ethernet
 encapsulation dot1ah isid 30000
 bridge-domain 20 c-mac
```

VFI Configuration

```
12 vfi myvfi manual
 vpn id 20
 neighbor 172.16.10.12 2000 encapsulation mpls
 neighbor 172.16.200.120 2000 encapsulation mpls
 vpn id vpn-id
```

SVI Configuration

```
interface vlan 100
 xconnect vfi vfi100
```

Additional References

Related Documents

Related Topic	Document Title
MAC-in-MAC commands: complete command syntax, command mode, command history, defaults, usage guidelines, and examples	Cisco IOS Carrier Ethernet Command Reference
Cisco IOS commands: master list of commands with complete command syntax, command mode, command history, defaults, usage guidelines, and examples	Cisco IOS Master Commands List, All Releases

Standards

Standard	Title
IEEE 802.1ah	IEEE 802.1ah - Provider Backbone Bridges

MIBs

MIB	MIBs Link
None	To locate and download MIBs for selected platforms, Cisco software releases, and feature sets, use Cisco MIB Locator found at the following URL: http://www.cisco.com/go/mibs

RFCs

RFC	Title
No new or modified RFCs are supported by this feature, and support for existing RFCs has not been modified by this feature.	--

Technical Assistance

Description	Link
The Cisco Support and Documentation website provides online resources to download documentation, software, and tools. Use these resources to install and configure the software and to troubleshoot and resolve technical issues with Cisco products and technologies. Access to most tools on the Cisco Support and Documentation website requires a Cisco.com user ID and password.	http://www.cisco.com/cisco/web/support/index.html

Feature Information for IEEE 802.1ah on Provider Backbone Bridges

The following table provides release information about the feature or features described in this module. This table lists only the software release that introduced support for a given feature in a given software release train. Unless noted otherwise, subsequent releases of that software release train also support that feature.

Use Cisco Feature Navigator to find information about platform support and Cisco software image support. To access Cisco Feature Navigator, go to www.cisco.com/go/cfn. An account on Cisco.com is not required.

Table 3: Feature Information for IEEE 802.1ah on Provider Backbone Bridges feature.

Feature Name	Releases	Feature Information
802.1ah/EVC2.0 for 7600 (Infrastructure)	12.2(33)SRE	<p>The IEEE 802.1ah on Provider Backbone Bridges feature enables MAC-in-MAC on EVCs.</p> <p>In Cisco IOS Release 12.2(33)SRE, this feature was introduced on the Cisco 7600 series routers.</p> <p>The following commands were introduced or modified:</p> <p>bridge-domain, clear bridge-domain mac table, description, encapsulation dot1ah isid, ethernet mac-tunnel virtual, mac tunnel address destination default, mac tunnel address destination map, service instance ethernet(mac-tunnel), show bridge-domain, show ethernet mac-tunnel engine slot, show ethernet service instance, show ethernet service mac-tunnel.</p>