



## **IP Addressing: NHRP Configuration Guide, Cisco IOS XE Release 2**

### **Americas Headquarters**

Cisco Systems, Inc.  
170 West Tasman Drive  
San Jose, CA 95134-1706  
USA  
<http://www.cisco.com>  
Tel: 408 526-4000  
800 553-NETS (6387)  
Fax: 408 527-0883

THE SPECIFICATIONS AND INFORMATION REGARDING THE PRODUCTS IN THIS MANUAL ARE SUBJECT TO CHANGE WITHOUT NOTICE. ALL STATEMENTS, INFORMATION, AND RECOMMENDATIONS IN THIS MANUAL ARE BELIEVED TO BE ACCURATE BUT ARE PRESENTED WITHOUT WARRANTY OF ANY KIND, EXPRESS OR IMPLIED. USERS MUST TAKE FULL RESPONSIBILITY FOR THEIR APPLICATION OF ANY PRODUCTS.

THE SOFTWARE LICENSE AND LIMITED WARRANTY FOR THE ACCOMPANYING PRODUCT ARE SET FORTH IN THE INFORMATION PACKET THAT SHIPPED WITH THE PRODUCT AND ARE INCORPORATED HEREIN BY THIS REFERENCE. IF YOU ARE UNABLE TO LOCATE THE SOFTWARE LICENSE OR LIMITED WARRANTY, CONTACT YOUR CISCO REPRESENTATIVE FOR A COPY.

The Cisco implementation of TCP header compression is an adaptation of a program developed by the University of California, Berkeley (UCB) as part of UCB's public domain version of the UNIX operating system. All rights reserved. Copyright © 1981, Regents of the University of California.

NOTWITHSTANDING ANY OTHER WARRANTY HEREIN, ALL DOCUMENT FILES AND SOFTWARE OF THESE SUPPLIERS ARE PROVIDED "AS IS" WITH ALL FAULTS. CISCO AND THE ABOVE-NAMED SUPPLIERS DISCLAIM ALL WARRANTIES, EXPRESSED OR IMPLIED, INCLUDING, WITHOUT LIMITATION, THOSE OF MERCHANTABILITY, FITNESS FOR A PARTICULAR PURPOSE AND NONINFRINGEMENT OR ARISING FROM A COURSE OF DEALING, USAGE, OR TRADE PRACTICE.

IN NO EVENT SHALL CISCO OR ITS SUPPLIERS BE LIABLE FOR ANY INDIRECT, SPECIAL, CONSEQUENTIAL, OR INCIDENTAL DAMAGES, INCLUDING, WITHOUT LIMITATION, LOST PROFITS OR LOSS OR DAMAGE TO DATA ARISING OUT OF THE USE OR INABILITY TO USE THIS MANUAL, EVEN IF CISCO OR ITS SUPPLIERS HAVE BEEN ADVISED OF THE POSSIBILITY OF SUCH DAMAGES.

Cisco and the Cisco logo are trademarks or registered trademarks of Cisco and/or its affiliates in the U.S. and other countries. To view a list of Cisco trademarks, go to this URL: [www.cisco.com/go/trademarks](http://www.cisco.com/go/trademarks). Third-party trademarks mentioned are the property of their respective owners. The use of the word partner does not imply a partnership relationship between Cisco and any other company. (1110R)

Any Internet Protocol (IP) addresses and phone numbers used in this document are not intended to be actual addresses and phone numbers. Any examples, command display output, network topology diagrams, and other figures included in the document are shown for illustrative purposes only. Any use of actual IP addresses or phone numbers in illustrative content is unintentional and coincidental.

© 2011 Cisco Systems, Inc. All rights reserved.



## CONTENTS

### Configuring NHRP 1

Finding Feature Information 1

Information About NHRP 1

How NHRP and NBMA Networks Interact 1

Dynamically Built Hub-and-Spoke Networks 2

Next Hop Server Selection 3

NHRP Registration 4

NHRP Used with a DMVPN 5

Dynamic Spoke-to-Spoke Tunnels 5

Developmental Phases of DMVPN and NHRP 5

Spoke Refresh Mechanism for Spoke-to-Spoke Tunnels 6

Process Switching 7

CEF Switching 7

How to Configure NHRP 7

Configuring a GRE Tunnel for Multipoint Operation 8

Enabling NHRP on an Interface 9

Configuring a Static IP-to-NBMA Address Mapping on a Station 11

Statically Configuring a Next Hop Server 12

Changing the Length of Time NBMA Addresses Are Advertised as Valid 13

Specifying the NHRP Authentication String 15

Configuring NHRP Server-Only Mode 16

Controlling the Triggering of NHRP 17

Triggering NHRP on a Per-Destination Basis 17

Triggering NHRP on a Packet Count Basis 19

Triggering NHRP Based on Traffic Thresholds 20

Changing the Rate for Triggering SVCs 20

Changing the Sampling Time Period and Sampling Rate 22

Applying the Triggering and Teardown Rates to Specific Destinations 23

Controlling the NHRP Packet Rate 24

Suppressing Forward and Reverse Record Options	26
Specifying the NHRP Responder IP Address	27
Clearing the NHRP Cache	28
Configuration Examples for NHRP	29
Physical Network Designs for Logical NBMA Examples	29
Applying NHRP Rates to Specific Destinations Example	31
NHRP on a Multipoint Tunnel Example	32
Show NHRP Examples	32
Additional References	34
Feature Information for Configuring NHRP	35
<b>Shortcut Switching Enhancements for NHRP in DMVPN Networks</b>	<b>37</b>
Finding Feature Information	37
Information About Shortcut Switching Enhancements for NHRP	37
DMVPN Phase 3 Networks Overview	38
Benefits of NHRP Shortcut Switching Enhancements	38
NHRP as a Route Source	39
Next Hop Overrides	40
NHRP Route Watch Infrastructure	40
NHRP Purge Request Reply	40
How to Configure Shortcut Switching for NHRP	40
Enabling NHRP Shortcut Switching on an Interface	41
Clearing NHRP Cache Entries on an Interface	42
Configuration Examples for Shortcut Switching Enhancements for NHRP	43
Configuring NHRP Shortcut Switching Example	43
Additional References	47
Feature Information for Shortcut Switching Enhancements for NHRP in DMVPN Networks	48



## Configuring NHRP

---

The Next Hop Resolution Protocol (NHRP) is an Address Resolution Protocol (ARP)-like protocol that dynamically maps a Non-Broadcast Multi-Access (NBMA) network. With NHRP, systems attached to an NBMA network can dynamically learn the NBMA (physical) address of the other systems that are part of that network, allowing these systems to directly communicate.

NHRP is a client and server protocol where the hub is the Next Hop Server (NHS) and the spokes are the Next Hop Clients (NHCs). The hub maintains an NHRP database of the public interface addresses of each spoke. Each spoke registers its real address when it boots and queries the NHRP database for real addresses of the destination spokes to build direct tunnels.

- [Finding Feature Information, page 1](#)
- [Information About NHRP, page 1](#)
- [How to Configure NHRP, page 7](#)
- [Configuration Examples for NHRP, page 29](#)
- [Additional References, page 34](#)
- [Feature Information for Configuring NHRP, page 35](#)

## Finding Feature Information

Your software release may not support all the features documented in this module. For the latest feature information and caveats, see the release notes for your platform and software release. To find information about the features documented in this module, and to see a list of the releases in which each feature is supported, see the Feature Information Table at the end of this document.

Use Cisco Feature Navigator to find information about platform support and Cisco software image support. To access Cisco Feature Navigator, go to [www.cisco.com/go/cfn](http://www.cisco.com/go/cfn). An account on Cisco.com is not required.

## Information About NHRP

- [How NHRP and NBMA Networks Interact, page 1](#)
- [Dynamically Built Hub-and-Spoke Networks, page 2](#)
- [Dynamic Spoke-to-Spoke Tunnels, page 5](#)
- [Spoke Refresh Mechanism for Spoke-to-Spoke Tunnels, page 6](#)

## How NHRP and NBMA Networks Interact

Most WAN networks are a collection of point-to-point links. Virtual tunnel networks (for example Generic Routing Encapsulation (GRE) tunnels) are also a collection of point-to-point links. To effectively scale the

connectivity of these point-to-point links, they are usually grouped into a single or multilayer hub-and-spoke network. Multipoint interfaces (for example, GRE tunnel interfaces) can be used to reduce the configuration on a hub router in such a network. This resulting network is a Non-Broadcast Multi-Access (NBMA) network.

Because there are multiple tunnel endpoints reachable through the single multipoint interface, there needs to be a mapping from the logical tunnel endpoint IP address to the physical tunnel endpoint IP address in order to forward packets out the multipoint GRE (mGRE) tunnel interfaces over this NBMA network. This mapping could be statically configured, but it is preferable if the mapping can be discovered or learned dynamically.

NHRP is an ARP-like protocol that alleviates these NBMA network problems. With NHRP, systems attached to an NBMA network dynamically learn the NBMA address of the other systems that are part of that network, allowing these systems to directly communicate without requiring traffic to use an intermediate hop.

Routers, access servers, and hosts can use NHRP to discover the addresses of other routers and hosts connected to an NBMA network. Partially meshed NBMA networks typically have multiple logical networks behind the NBMA network. In such configurations, packets traversing the NBMA network might have to make several hops over the NBMA network before arriving at the exit router (the router nearest the destination network). When NHRP is combined with IPsec, the NBMA network is basically a collection of point-to-point logical tunnel links over a physical IP network.

NHRP allows two functions to help support these NBMA networks:

- 1 **NHRP Registration.** NHRP allows Next Hop Clients (NHCs) to dynamically register with Next Hop Servers (NHSs). This registration function allows the NHCs to join the NBMA network without configuration changes on the NHSs, especially in cases where the NHC has a dynamic physical IP address or is behind a Network Address Translation (NAT) router that dynamically changes the physical IP address. In these cases, it would be impossible to preconfigure the logical virtual private network (VPN IP) to physical (NBMA IP) mapping for the NHC on the NHS. See the `NHRP_Registration` section for more information.
- 2 **NHRP Resolution.** NHRP allows one NHC (spoke) to dynamically discover the logical VPN IP to physical NBMA IP mapping for another NHC (spoke) within the same NBMA network. Without this discovery, IP packets traversing from hosts behind one spoke to hosts behind another spoke would have to traverse by way of the NHS (hub) router. This process would increase the utilization of the hub's physical bandwidth and CPU to process these packets that enter and exit the hub on the multipoint interface. With NHRP, systems attached to an NBMA network dynamically learn the NBMA address of the other systems that are part of that network, allowing these systems to directly communicate without requiring traffic to use an intermediate hop. This function alleviates the load on the intermediate hop (NHS) and can increase the overall bandwidth of the NBMA network to be greater than the bandwidth of the hub router.

## Dynamically Built Hub-and-Spoke Networks

With NHRP, the NBMA network is initially laid out as a hub-and-spoke network that can be multiple hierarchical layers of NHCs as spokes and NHSs as hubs. The NHCs are configured with static mapping information to reach their NHSs and will connect to their NHS and send an NHRP registration to the NHS. This configuration allows the NHS to dynamically learn the mapping information for the spoke, reducing the configuration needed on the hub and allowing the spoke to obtain a dynamic NBMA (physical) IP address.

Once the base hub-and-spoke network is dynamically built, NHRP resolution requests and responses can be used to dynamically discover spoke-to-spoke mapping information, which allows spokes to bypass the hub and contact each other directly. This process allows a dynamic mesh of connections between spokes to be

built based on data traffic patterns without requiring a preconfigured static fully meshed network. Using a dynamic-mesh network allows smaller spoke routers to participate up to their capability in a large NBMA network when these smaller spoke routers do not have the resources to participate in a full mesh on the same size network. The smaller spoke routers do not need to build out all possible spoke-to-spoke links; these routers need to build only the ones they are currently using.

- [Next Hop Server Selection, page 3](#)
- [NHRP Registration, page 4](#)
- [NHRP Used with a DMVPN, page 5](#)

## Next Hop Server Selection

NHRP resolution requests traverse one or more hops (hubs) within the base hub-and-spoke NBMA subnetwork before reaching the station that is expected to generate a response. Each station (including the source station) chooses a neighboring NHS to which it forwards the request. The NHS selection procedure typically involves performing a routing decision based upon the network layer destination address of the NHRP request. The NHRP resolution request eventually arrives at a station that generates an NHRP resolution reply. This responding station either serves the destination, or is the destination itself. The responding station generates a reply using the source address from within the NHRP packet to determine where the reply should be sent.

The Cisco implementation of NHRP also supports and extends the IETF RFC 2332, *NBMA Next Hop Resolution Protocol (NHRP)*.

The figure below illustrates four routers connected to an NBMA network. Within the network are IP routers necessary for the routers to communicate with each other by tunneling the IP data packets in GRE IP tunnel packets. The infrastructure layer routers support logical IP tunnel circuit connections represented by hops 1, 2, and 3. When router A attempts to forward an IP packet from the source host to the destination host, NHRP is triggered. On behalf of the source host, router A sends an NHRP resolution request packet encapsulated in a GRE IP packet, which takes three hops across the network to reach router D, connected to the destination host. After router A receives a positive NHRP resolution reply, router A determines that

router D is the NBMA IP next hop, and router A sends subsequent data IP packets for the destination to router D in one GRE IP tunnel hop.

**Figure 1** Next Hop Resolution Protocol

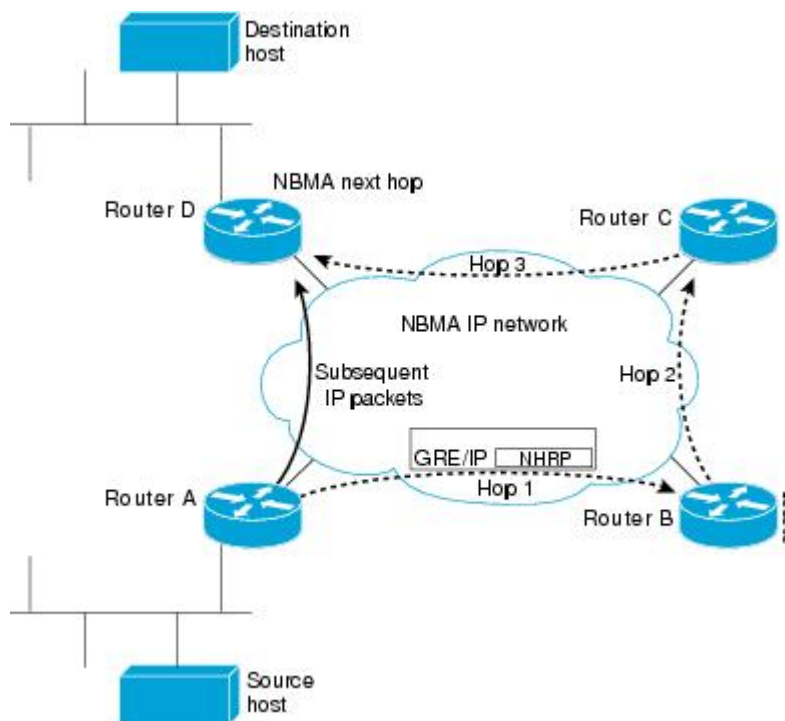

With NHRP, once the NBMA next hop is determined, the source either starts sending data packets to the destination (in a connectionless NBMA network such as GRE IP or SMDS) or establishes a virtual circuit (VC) connection to the destination. This connection is configured with the desired bandwidth and quality of service (QoS) characteristics for a connection-oriented NBMA network (such as Frame Relay or ATM) or with Dynamic Multipoint VPN (DMVPN) where an IPsec encryption peering must be established.

Other address resolution methods can be used while NHRP is deployed. IP hosts that rely upon the Logical IP Subnet (LIS) model might require ARP servers and services over the NBMA network, and deployed hosts might not implement NHRP, but might continue to support ARP variations. NHRP is designed to eliminate the suboptimal routing that results from the LIS model, and can be deployed with existing ARP services without interfering with them.

## NHRP Registration

NHRP registrations are sent from NHCs to their configured NHSs every one-third of the NHRP holdtime (configured by the `ip nhrp holdtime value command`), unless the `ip nhrp registration timeout value command` is configured, in which case registrations are sent out according to the configured timeout value. If an NHRP registration reply is not received for an NHRP registration request, the NHRP registration request is retransmitted at timeouts of 1, 2, 4, 8, 16, 32, and 64 seconds, then the sequence starts over again at 1.

The NHS is declared down if an NHRP registration reply is not received after three retransmission (7 seconds), and an NHRP resolution packets will no longer be sent to or by way of that NHS. NHRP registrations will continue to be sent at 1-, 2-, 4-, 8-, 16-, 32-, and 64-second intervals, probing the NHS until an NHRP registration reply is received. As soon as an NHRP registration reply is received the NHS is



immediately declared up, the NHRP registration requests revert to being sent every one-third of NHRP holdtime or the value configured in the `ip nhrp registration timeout` command, and the NHS can again be sent NHRP resolution requests. The `show ip nhrp nhs detail` command can be used to check the state of the NHRP NHSs.

## NHRP Used with a DMVPN

NHRP can be used to help build a VPN. In this context, a VPN consists of a virtual Layer 3 network that is built on top of an actual Layer 3 network. The topology you use over the VPN is largely independent of the underlying network, and the protocols you run over it are completely independent of it. The Dynamic Multipoint VPN (DMVPN) is based on GRE IP logical tunnels that can be protected by adding in IPsec to encrypt the GRE IP tunnels.

## Dynamic Spoke-to-Spoke Tunnels

Spoke-to-spoke tunnels are designed to be dynamic, in that they are created only when there is data traffic to use the tunnel and they are removed when there is no longer any data traffic using the tunnel.

In addition to NHRP registration of NHCs with NHSs, NHRP provides the capability for NHCs (spokes) to find a shortcut path over the infrastructure of the network (IP network, SMDS) or build a shortcut switched virtual circuit (SVC) over a switched infrastructure network (Frame Relay and ATM) directly to another NHC (spoke), bypassing hops through the NHSs (hubs). This capability allows the building of very large NHRP NBMA networks. In this way, the bandwidth and CPU limitations of the hub do not limit the overall bandwidth of the NHRP NBMA network. This capability effectively creates a full-mesh-capable network without having to discover all possible connections beforehand. This type of network is called a dynamic-mesh network, where there is a base hub-and-spoke network of NHCs and NHSs for transporting NHRP and dynamic routing protocol information (and data traffic) and dynamic direct spoke-to-spoke links that are built when there is data traffic to use the link and torn down when the data traffic stops.

The dynamic-mesh network allows individual spoke routers to directly connect to anywhere in the NBMA network, even though they are capable of connecting only to a limited number at the same time. This functionality allows each spoke in the network to participate in the whole network up to its capabilities without limiting another spoke from participating up to its capability. If a full-mesh network were to be built, then all spokes would have to be sized to handle all possible tunnels at the same time.

For example, in a network of 1000 nodes, a full-mesh spoke would need to be large and powerful because it must always support 999 tunnels (one to every other node). In a dynamic-mesh network, a spoke needs to support only a limited number of tunnels to its NHSs (hubs) plus any currently active tunnels to other spokes. Also, if a spoke cannot build more spoke-to-spoke tunnels, then it will send its data traffic by way of the spoke-hub-spoke path. This design ensures that connectivity is always preserved, even when the preferred single hop path is not available.

- [Developmental Phases of DMVPN and NHRP, page 5](#)

## Developmental Phases of DMVPN and NHRP

The developmental phases described in this section are actually DMVPN phases combining mGRE plus NHRP and IPsec. Phase 2 is important because it provides the functionality needed to support dynamic spoke-to-spoke tunnels.

- Phase 1 is the hub-and-spoke capability only. This phase will not be discussed here because phase 1 does not support spoke-to-spoke tunnels.
- Phase 2 adds spoke-to-spoke capability.

NHRP gathers the information that it needs to build spoke-to-spoke tunnels by using NHRP resolution request and reply packets that are sent via the spoke-hub-spoke path through the NBMA network. NHRP also has to be triggered (or know when) to collect this information for building the spoke-to-spoke tunnels, because it brings up the spoke-to-spoke tunnel only when there is data traffic to use it. The two ways that NHRP does this are described the following sections.

NHRP gathers the information that it needs to build spoke-to-spoke tunnels by using NHRP resolution request and reply packets that are sent via the spoke-hub-spoke path through the NBMA network. NHRP also has to be triggered (or know when) to collect this information for building the spoke-to-spoke tunnels, because it brings up the spoke-to-spoke tunnel only when there is data traffic to use it.

The IP routing table and the routes learned by way of the hub are important when building spoke-to-spoke tunnels. Therefore, the availability of the NHSs (hubs) is critical for the functioning of an NHRP-based network. When there is only one hub and that hub goes down, the spoke removes the routes that it learned from the hub from its routing table, because it lost the hub as its routing neighbor. However, the spoke does not delete any of the spoke-to-spoke tunnels (NHRP mappings) that are now up. Even though the spoke-to-spoke tunnel is still there the spoke will not be able to use the tunnel because its routing table no longer has a route to the destination network. The spoke has a path (spoke-to-spoke tunnel), but does not know to use it (because there is no routing table entry).

In addition, when the routing entries are removed there is no trigger into NHRP for NHRP to remove NHRP mapping entries. Eventually NHRP will time out the current dynamic NHRP mapping entries that it had when the hub went down because they are not being used. Only at that time does NHRP remove the mapping entry.

In phase 2, if there still happened to be a route in the routing table (could be a static route) with the correct IP next hop, then the spoke could still use the spoke-to-spoke tunnel even when the hub is down. NHRP will not be able to refresh the mapping entry because the NHRP resolution request or response would need to go through the hub.

If you have two (or more) NHS hubs within a single NBMA network (single mGRE, Frame Relay, or ATM interface), then when the first (primary) hub goes down, the spoke router will still remove the routes from the routing table that it learned from this hub, but it will also be learning the same routes (higher metric) from the second (backup) hub, so it will immediately install these routes. Therefore the spoke-to-spoke traffic would continue going over the spoke-to-spoke tunnel and be unaffected by the primary hub outage.

In phase 2, NHRP brings up the NHC-to-NHS tunnel and a dynamic routing protocol is used to distribute routing information about all of the networks that are available behind the hub and all of the other spokes. Included in this information is the IP next hop of the destination spoke that is supporting a particular destination network.

When a data packet is forwarded, it obtains the outbound interface and the IP next hop from the matching routing table network entry. If the NHRP interface is the outbound interface, it looks for an NHRP mapping entry for that IP next hop. If there is no matching of an NHRP mapping entry, then NHRP is triggered to send an NHRP resolution request to get the mapping information (IP next-hop address to physical layer address). The NHRP registration reply packet contains this mapping information. When this information is received, the spoke has enough information to correctly encapsulate the data packet to go directly to the remote spoke, taking one hop across the infrastructure network. One of the disadvantages to this technique is that each spoke must have all of the individual routes in its routing table for all possible destination networks behind the hub and other spokes. Keeping this routing information distributed and up to date can put a significant load on the routing protocol running over the VPN.

## Spoke Refresh Mechanism for Spoke-to-Spoke Tunnels

Spoke-to-spoke tunnels are designed to be dynamic, in that they are created only when there is data traffic to use the tunnel and they are removed when there is no longer any data traffic using the tunnel. This

section describes the mechanism to refresh the spoke-to-spoke tunnel when it is still being used (no packet loss) and to detect and remove the spoke-to-spoke tunnel when it is no longer being used.

- [Process Switching, page 7](#)
- [CEF Switching, page 7](#)

## Process Switching

Each time a data packet is switched using an NHRP mapping entry, the “used” flag is set on the mapping entry. Then when the NHRP background process runs (every 60 seconds) the following actions occur:

- If the expire time is >120 seconds and the “used” flag is set, then the “used” flag is cleared.
- If the expire time is <= 120 seconds and the “used” flag is set, then the entry is refreshed.
- If the expire time is <= 120 seconds and the “used” flag is not set, then nothing is done.

## CEF Switching

NHRP has no knowledge about when a packet is Cisco Express Forwarding (CEF) switched through the spoke-to-spoke tunnel.

When the NHRP background process runs, the following actions occur:

- If the expire time is > 120 seconds, then nothing is done.
- If the expire time is <= 120 seconds, then the corresponding CEF adjacency is marked “stale”. If the CEF adjacency is then used to switch a packet, CEF will mark the adjacency “fresh” and trigger NHRP to refresh the mapping entry.

In both the process and CEF switching cases, refreshed means that another NHRP resolution request is sent and response is needed to keep the entry from expiring. If the expiration time goes to 0 then the NHRP mapping entry is deleted. Also, if this entry is the last mapping entry with this NBMA address and if the router is CEF switching, then the CEF adjacency will be cleared and marked incomplete.

If the IPsec **tunnel protection ipsec profile** *name* command is used on an NHRP mGRE interface, then the following actions also occur:

- 1 The corresponding crypto socket entry is deleted.
- 2 The corresponding crypto map entry is deleted.
- 3 The corresponding IPsec security associations (SAs) and Internet Security Association and Key Management Protocol (ISAKMP) SAs are deleted.
- 4 Just prior to removing the ISAKMP SA, phase 2 and phase 1 delete notify messages are sent to the ISAKMP peer.
- 5 The ISAKMP peer deletes the corresponding IPsec SAs and ISAKMP SAs.
- 6 Via the crypto socket, the ISAKMP peer’s NHRP mapping entry sets its expire time set to 5 seconds, unless it is a static NHRP mapping entry.
- 7 When the NHRP mapping entry expires and if it is the last mapping entry with this NBMA address, then the ISAKMP peer also performs items 1 through 5.

## How to Configure NHRP

- [Configuring a GRE Tunnel for Multipoint Operation, page 8](#)
- [Enabling NHRP on an Interface, page 9](#)

- [Configuring a Static IP-to-NBMA Address Mapping on a Station, page 11](#)
- [Statically Configuring a Next Hop Server, page 12](#)
- [Changing the Length of Time NBMA Addresses Are Advertised as Valid, page 13](#)
- [Specifying the NHRP Authentication String, page 15](#)
- [Configuring NHRP Server-Only Mode, page 16](#)
- [Controlling the Triggering of NHRP, page 17](#)
- [Triggering NHRP Based on Traffic Thresholds, page 20](#)
- [Controlling the NHRP Packet Rate, page 24](#)
- [Suppressing Forward and Reverse Record Options, page 26](#)
- [Specifying the NHRP Responder IP Address, page 27](#)
- [Clearing the NHRP Cache, page 28](#)

## Configuring a GRE Tunnel for Multipoint Operation

Perform this task to configure a GRE tunnel for multipoint (NMBA) operation.

You can enable a GRE tunnel to operate in multipoint fashion. A tunnel network of multipoint tunnel interfaces can be thought of as an NBMA network. When multiple GRE tunnels are configured on the same router, they must either have unique tunnel ID keys or unique tunnel source addresses. NHRP is required on mGRE tunnel interfaces because it provides the VPN-layer-IP to NBMA-layer-IP address mappings for forwarding IP data packets over the mGRE tunnel.

If the tunnel ID key is carried in each GRE packet, it is not carried in any NHRP messages. We do not recommend relying on this key for security purposes.

### SUMMARY STEPS

1. **enable**
2. **configure terminal**
3. **interface** *type number*
4. **tunnel mode gre multipoint**
5. **tunnel key** *key-number*
6. **ip nhrp network-id** *number*

### DETAILED STEPS

	Command or Action	Purpose
Step 1	<b>enable</b>	Enables privileged EXEC mode.
	<b>Example:</b>	
	Router> enable	<ul style="list-style-type: none"> <li>• Enter your password if prompted.</li> </ul>

Command or Action	Purpose
<p><b>Step 2</b> <code>configure terminal</code></p> <p><b>Example:</b></p> <pre>Router# configure terminal</pre>	<p>Enters global configuration mode.</p>
<p><b>Step 3</b> <code>interface type number</code></p> <p><b>Example:</b></p> <pre>Router(config)# interface tunnel 100</pre>	<p>Configures an interface and enters interface configuration mode.</p>
<p><b>Step 4</b> <code>tunnel mode gre multipoint</code></p> <p><b>Example:</b></p> <pre>Router(config-if)# tunnel mode gre multipoint</pre>	<p>Enables a GRE tunnel to be used in multipoint NBMA mode.</p>
<p><b>Step 5</b> <code>tunnel key key-number</code></p> <p><b>Example:</b></p> <pre>Router(config-if)# tunnel key 3</pre>	<p>(Optional) Sets the tunnel ID key</p>
<p><b>Step 6</b> <code>ip nhrp network-id number</code></p> <p><b>Example:</b></p> <pre>Router(config-if)# ip nhrp network-id 1</pre>	<p>Enables NHRP on the interface.</p>

## Enabling NHRP on an Interface

Perform this task to enable NHRP for an interface on a router. In general, all NHRP stations within a logical NBMA network should be configured with the same network identifier.

The NHRP network ID is used to define the NHRP domain for an NHRP interface and differentiate between multiple NHRP domains or networks, when two or more NHRP domains (GRE tunnel interfaces) are available on the same NHRP node (router). The NHRP network ID is used to help keep two NHRP networks (clouds) separate from each other when both are configured on the same router.

The NHRP network ID is a local only parameter. It is significant only to the local router and is not transmitted in NHRP packets to other NHRP nodes. For this reason the actual value of the NHRP network ID configured on a router need not match the same NHRP network ID on another router where both of these routers are in the same NHRP domain. As NHRP packets arrive on a GRE interface, they are assigned to the local NHRP domain in the NHRP network ID that is configured on that interface.

**Note**

This method of assigning a network ID is similar to the Open Shortest Path First (OSPF) concept of process ID in the **router ospf process- id** command. If more than one OSPF process is configured, then the OSPF neighbors and any routing data that they provide is assigned to the OSPF process (domain) by which interfaces map to the *network* arguments under the different **router ospf process-id** configuration blocks.

We recommend that the same NHRP network ID be used on the GRE interfaces on all routers that are in the same NHRP network. It is then easier to track which GRE interfaces are members of which NHRP network.

NHRP domains (network IDs) can be unique on each GRE tunnel interface on a router. This is required when running DMVPN phase 1 or phase 2 or when using a tunnel key on the GRE interfaces. These unique IDs place each GRE interface into a different NHRP domain, which is equivalent to each being in a unique DMVPN.

NHRP domains can span across GRE tunnel interfaces on a route. This option is available when running DMVPN phase 3 and not using a tunnel key on the GRE tunnel interfaces. In this case the effect of using the same NHRP network ID on the GRE tunnel interfaces is to merge the two GRE interfaces into a single NHRP network (DMVPN network).

**SUMMARY STEPS**

1. **enable**
2. **configure terminal**
3. **interface** *type number*
4. **ip address** *ip-address network-mask*
5. **ip nhrp network-id** *number*
6. **end**

**DETAILED STEPS**

Command or Action	Purpose
<b>Step 1</b> <b>enable</b>  <b>Example:</b> Router> enable	Enables privileged EXEC mode. <ul style="list-style-type: none"> <li>• Enter your password if prompted.</li> </ul>
<b>Step 2</b> <b>configure terminal</b>  <b>Example:</b> Router# configure terminal	Enters global configuration mode.
<b>Step 3</b> <b>interface</b> <i>type number</i>  <b>Example:</b> Router(config)# interface tunnel 100	Configures an interface and enters interface configuration mode.

Command or Action	Purpose
<b>Step 4</b> <code>ip address ip-address network-mask</code>  <b>Example:</b> <pre>Router(config-if)# ip address 10.0.0.1 255.255.255.0</pre>	Enables IP and gives the interface an IP address.
<b>Step 5</b> <code>ip nhrp network-id number</code>  <b>Example:</b> <pre>Router(config-if)# ip nhrp network-id 1</pre>	Enables NHRP on the interface.
<b>Step 6</b> <code>end</code>  <b>Example:</b> <pre>Router(config)# end</pre>	Exits interface configuration mode and returns to privileged EXEC mode.

## Configuring a Static IP-to-NBMA Address Mapping on a Station

Perform this task to configure static IP-to-NBMA address mapping on a station (host or router). To enable IP multicast and broadcast packets to be sent to the statically configured station, use the **ip nhrp map multicast nbma-address** command. This command is required on multipoint GRE tunnels and not required on point-point RE tunnels.

To participate in NHRP, a station connected to an NBMA network must be configured with the IP and NBMA addresses of its NHSs. The format of the NBMA address depends on the medium you are using. For example, GRE uses a network service access point (NSAP) address, Ethernet uses a MAC address, and SMDS uses an E.164 address.

These NHSs may also be the default or peer routers of the station, so their addresses can be obtained from the network layer forwarding table of the station.

If the station is attached to several link layer networks (including logical NBMA networks), the station should also be configured to receive routing information from its NHSs and peer routers so that it can determine which IP networks are reachable through which link layer networks.

Perform this task to configure static IP-to-NBMA address mapping on a station (host or router). To enable IP multicast and broadcast packets to be sent to the statically configured station, use the **ip nhrp map multicast nbma-address** command. This step is required on multipoint GRE tunnels and not required on point-point RE tunnels.



### Note

The IGP routing protocol uses IP multicast or broadcast, so the **ip nhrp map multicast** command, though optional, is often required.

**SUMMARY STEPS**

1. **enable**
2. **configure terminal**
3. **interface** *type number*
4. **ip nhrp map** *ip-address nbma-address*
5. **ip nhrp map multicast** *nbma-address*

**DETAILED STEPS**

Command or Action	Purpose
<b>Step 1</b> <b>enable</b>  <b>Example:</b> <pre>Router&gt; enable</pre>	Enables privileged EXEC mode. <ul style="list-style-type: none"> <li>• Enter your password if prompted.</li> </ul>
<b>Step 2</b> <b>configure terminal</b>  <b>Example:</b> <pre>Router# configure terminal</pre>	Enters global configuration mode.
<b>Step 3</b> <b>interface</b> <i>type number</i>  <b>Example:</b> <pre>Router(config)# interface tunnel 100</pre>	Configures an interface and enters interface configuration mode.
<b>Step 4</b> <b>ip nhrp map</b> <i>ip-address nbma-address</i>  <b>Example:</b> <pre>Router(config-if)# ip nhrp map 10.0.0.2 172.16.1.2</pre>	Configures static IP-to-NBMA address mapping on the station.
<b>Step 5</b> <b>ip nhrp map multicast</b> <i>nbma-address</i>  <b>Example:</b> <pre>Router(config-if)# ip nhrp map multicast 172.16.1.12</pre>	(Optional) Adds an NBMA address to receive multicast or broadcast packets sent out the interface.  <b>Note</b> This command is not required on point-to-point GRE tunnels.

**Statically Configuring a Next Hop Server**

Perform this task to statically configure a Next Hop Server.

An NHS normally uses the network layer forwarding table to determine where to forward NHRP packets and to find the egress point from an NBMA network. An NHS may also be statically configured with a set



of IP address prefixes that correspond to the IP addresses of the stations it serves, and their logical NBMA network identifiers.

### SUMMARY STEPS

1. **enable**
2. **configure terminal**
3. **interface** *type number*
4. **ip nhrp nhs** *nhs-address* [*net-address* [*netmask*]]

### DETAILED STEPS

Command or Action	Purpose
<p><b>Step 1</b> <b>enable</b></p> <p><b>Example:</b></p> <pre>Router&gt; enable</pre>	<p>Enables privileged EXEC mode.</p> <ul style="list-style-type: none"> <li>• Enter your password if prompted.</li> </ul>
<p><b>Step 2</b> <b>configure terminal</b></p> <p><b>Example:</b></p> <pre>Router# configure terminal</pre>	<p>Enters global configuration mode.</p>
<p><b>Step 3</b> <b>interface</b> <i>type number</i></p> <p><b>Example:</b></p> <pre>Router(config)# interface tunnel 100</pre>	<p>Configures an interface and enters interface configuration mode.</p>
<p><b>Step 4</b> <b>ip nhrp nhs</b> <i>nhs-address</i> [<i>net-address</i> [<i>netmask</i>]]</p> <p><b>Example:</b></p> <pre>Router(config-if)# ip nhrp nhs 10.0.0.2</pre>	<p>Statically configures a Next Hop Server.</p> <ul style="list-style-type: none"> <li>• To configure multiple networks that the Next Hop Server serves, repeat the <b>ip nhrp nhs</b> command with the same Next Hop Server address, but different IP network addresses.</li> <li>• To configure additional Next Hop Servers, repeat the <b>ip nhrp nhs</b> command.</li> </ul>

## Changing the Length of Time NBMA Addresses Are Advertised as Valid

Perform this task to change the length of time that NBMA addresses are advertised as valid in positive NHRP responses. In this context, *advertised* means how long the Cisco IOS XE software tells other routers to keep the address mappings it is providing in NHRP responses. The default length of time is 7200 seconds (2 hours).

This configuration controls how long a spoke-to-spoke shortcut path will stay up after it is no longer used or how often the spoke-to-spoke short-cut path mapping entry will be refreshed if it is still being used. We recommend that a value from 300 to 600 seconds be used.

The **ip nhrp holdtime** command controls how often the NHRP NHC will send NHRP registration requests to its configured NHRP NHSs. The default is to send NHRP registrations every one-third the NHRP

holdtime value (default = 2400 seconds (40 minutes)). The optional **ip nhrp registration timeout** *value* command can be used to set the interval for sending NHRP registration requests independently from the NHRP holdtime.

### SUMMARY STEPS

1. **enable**
2. **configure terminal**
3. **interface** *type number*
4. **ip nhrp holdtime** *seconds*
5. **ip nhrp registration timeout** *seconds*

### DETAILED STEPS

Command or Action	Purpose
<p><b>Step 1</b> <b>enable</b></p> <p><b>Example:</b></p> <pre>Router&gt; enable</pre>	<p>Enables privileged EXEC mode.</p> <ul style="list-style-type: none"> <li>• Enter your password if prompted.</li> </ul>
<p><b>Step 2</b> <b>configure terminal</b></p> <p><b>Example:</b></p> <pre>Router# configure terminal</pre>	<p>Enters global configuration mode.</p>
<p><b>Step 3</b> <b>interface</b> <i>type number</i></p> <p><b>Example:</b></p> <pre>Router(config)# interface tunnel 100</pre>	<p>Configures an interface and enters interface configuration mode.</p>
<p><b>Step 4</b> <b>ip nhrp holdtime</b> <i>seconds</i></p> <p><b>Example:</b></p> <pre>Router(config-if)# ip nhrp holdtime 600</pre>	<p>Changes the number of seconds that NHRP NBMA addresses are advertised as valid in positive NHRP responses.</p> <ul style="list-style-type: none"> <li>• In this example, NHRP NBMA addresses are advertised as valid in positive NHRP responses for 10 minutes.</li> </ul>
<p><b>Step 5</b> <b>ip nhrp registration timeout</b> <i>seconds</i></p> <p><b>Example:</b></p> <pre>Router(config-if)# ip nhrp registration timeout 100</pre>	<p>(Optional) Changes the interval that NHRP NHCs send NHRP registration requests to configured NHRP NHSs.</p> <ul style="list-style-type: none"> <li>• In this example, NHRP registration requests are now sent every 100 seconds (default value is one third NHRP holdtime value).</li> </ul>

## Specifying the NHRP Authentication String

Perform this task to specify the authentication string for NHRP on an interface.

Configuring an authentication string ensures that only routers configured with the same string can communicate using NHRP. Therefore, if the authentication scheme is to be used, the same string must be configured in all devices configured for NHRP on a fabric.



### Note

We recommend using an NHRP authentication string, especially to help keep multiple NHRP domains separate from each other. The NHRP authentication string is not encrypted, so it cannot be used as a true authentication for an NHRP node trying to enter the NHRP network.

### SUMMARY STEPS

1. **enable**
2. **configure terminal**
3. **interface** *type number*
4. **ip nhrp authentication** *string*
5. **exit**
6. **show ip nhrp** [**dynamic** | **static**] [*type number*]
7. **show ip nhrp traffic**
8. **show ip nhrp nhs** [**detail**]

### DETAILED STEPS

	Command or Action	Purpose
<b>Step 1</b>	<b>enable</b>  <b>Example:</b> Router> enable	Enables privileged EXEC mode. <ul style="list-style-type: none"> <li>• Enter your password if prompted.</li> </ul>
<b>Step 2</b>	<b>configure terminal</b>  <b>Example:</b> Router# configure terminal	Enters global configuration mode.
<b>Step 3</b>	<b>interface</b> <i>type number</i>  <b>Example:</b> Router(config)# interface tunnel 100	Configures an interface and enters interface configuration mode.

Command or Action	Purpose
<p><b>Step 4</b> <code>ip nhrp authentication <i>string</i></code></p> <p><b>Example:</b></p> <pre>Router(config-if)# ip nhrp authentication specialxx</pre>	<p>Specifies an authentication string.</p> <ul style="list-style-type: none"> <li>All routers configured with NHRP within one logical NBMA network must share the same authentication string.</li> </ul>
<p><b>Step 5</b> <code>exit</code></p> <p><b>Example:</b></p> <pre>Router(config-if)# exit</pre>	<p>Exits interface configuration mode and returns to privileged EXEC mode.</p>
<p><b>Step 6</b> <code>show ip nhrp [dynamic   static] [type number]</code></p> <p><b>Example:</b></p> <pre>Router# show ip nhrp</pre>	<p>Displays the IP NHRP cache, which can be limited to dynamic or static cache entries for a specific interface.</p>
<p><b>Step 7</b> <code>show ip nhrp traffic</code></p> <p><b>Example:</b></p> <pre>Router# show ip nhrp traffic</pre>	<p>Displays NHRP traffic statistics.</p>
<p><b>Step 8</b> <code>show ip nhrp nhs [detail]</code></p> <p><b>Example:</b></p> <pre>Router# show ip nhrp nhs detail</pre>	<p>Displays NHRP holdtime details.</p>

## Configuring NHRP Server-Only Mode

Perform this task to configure NHRP server-only mode.

You can configure an interface so that it cannot initiate NHRP resolution requests to establish NHRP shortcut SVCs but can respond only to NHRP resolution requests. Configure NHRP server-only mode on routers you do not want placing NHRP resolution requests.

If an interface is placed in NHRP server-only mode, you have the option to specify the **ip nhrp server-only [non-caching]** command keyword. In this case, NHRP does not store mapping information in the NHRP cache, such as NHRP responses that go through the router. To save memory and block building of NHRP shortcuts, the non-caching option is generally used on a router located between two other NHRP routers (NHRP hubs).

Perform this task to configure NHRP server-only mode.

**SUMMARY STEPS**

1. **enable**
2. **configure terminal**
3. **interface** *type number*
4. **ip nhrp server-only** [non-caching]

**DETAILED STEPS**

	<b>Command or Action</b>	<b>Purpose</b>
<b>Step 1</b>	<b>enable</b>  <b>Example:</b> Router> enable	Enables privileged EXEC mode. <ul style="list-style-type: none"> <li>• Enter your password if prompted.</li> </ul>
<b>Step 2</b>	<b>configure terminal</b>  <b>Example:</b> Router# configure terminal	Enters global configuration mode.
<b>Step 3</b>	<b>interface</b> <i>type number</i>  <b>Example:</b> Router(config)# interface tunnel 100	Configures an interface and enters interface configuration mode.
<b>Step 4</b>	<b>ip nhrp server-only</b> [non-caching]  <b>Example:</b> Router(config-if)# ip nhrp server-only non-caching	Configures NHRP server-only mode.

**Controlling the Triggering of NHRP**

There are two ways to control when NHRP is triggered on any platform. These methods are described in the following sections:

- [Triggering NHRP on a Per-Destination Basis, page 17](#)
- [Triggering NHRP on a Packet Count Basis, page 19](#)

**Triggering NHRP on a Per-Destination Basis**

Perform the following task to trigger NHRP on a per-destination basis.

You can specify an IP access list that is used to decide which IP packets can trigger the sending of NHRP resolution requests. By default, all non-NHRP packets trigger NHRP resolution requests. To limit which IP packets trigger NHRP resolution requests, define an access list and then apply it to the interface.

**Note**

NHRP resolution requests are used to build direct paths between two NHRP nodes. Even though certain traffic is excluded from triggering the building of this path, if the path is already built then this “excluded” traffic will use the direct path.

**SUMMARY STEPS**

1. **enable**
2. **configure terminal**
3. Do one of the following:
  - **access-list** *access-list-number* { **deny** | **permit** } *source*[*source-wildcard*]
  - **access-list** *access-list-number* { **deny** | **permit** } *protocol source source-wildcard destination destination-wildcard*[**precedence precedence**] [**tos tos**] [**established**] [**log**]
4. **interface** *type number*
5. **ip nhrp interest** *access-list-number*

**DETAILED STEPS**

Command or Action	Purpose
<b>Step 1</b> <b>enable</b>  <b>Example:</b> Router> enable	Enables privileged EXEC mode. <ul style="list-style-type: none"> <li>• Enter your password if prompted.</li> </ul>
<b>Step 2</b> <b>configure terminal</b>  <b>Example:</b> Router# configure terminal	Enters global configuration mode.

Command or Action	Purpose
<p><b>Step 3</b> Do one of the following:</p> <ul style="list-style-type: none"> <li>• <b>access-list</b> <i>access-list-number</i> {deny   permit} <i>source</i>[<i>source-wildcard</i>]</li> <li>• <b>access-list</b> <i>access-list-number</i> {deny   permit} <i>protocol source source-wildcard destination destination-wildcard</i>[<b>precedence precedence</b>] [<b>tos tos</b>] [<b>established</b>] [<b>log</b>]</li> </ul> <p><b>Example:</b></p> <pre>Router(config)# access-list 101 permit ip any any</pre> <p><b>Example:</b></p> <pre>Router(config)# access-list 101 deny ip any 10.3.0.0 0.0.255.255</pre>	<p>Defines a standard or extended IP access list.</p>
<p><b>Step 4</b> <b>interface</b> <i>type number</i></p> <p><b>Example:</b></p> <pre>Router(config)# interface tunnel 100</pre>	<p>Configures an interface and enters interface configuration mode.</p>
<p><b>Step 5</b> <b>ip nhrp interest</b> <i>access-list-number</i></p> <p><b>Example:</b></p> <pre>Router(config-if)# ip nhrp interest 101</pre>	<p>Specifies an IP access list that controls NHRP requests.</p> <ul style="list-style-type: none"> <li>• In this example, only the packets that pass extended access list 101 are subject to the default SVC triggering and teardown rates.</li> </ul>

## Triggering NHRP on a Packet Count Basis

By default, when the software attempts to send a data packet to a destination for which it has determined that NHRP can be used, it sends an NHRP request for that destination. Perform this task to configure the system to wait until a specified number of data packets have been sent to a particular destination before NHRP is attempted.

### SUMMARY STEPS

1. **enable**
2. **configure terminal**
3. **interface** *type number*
4. **ip nhrp use** *usage-count*

## DETAILED STEPS

Command or Action	Purpose
<b>Step 1</b> <code>enable</code>  <b>Example:</b> <pre>Router&gt; enable</pre>	Enables privileged EXEC mode. <ul style="list-style-type: none"> <li>Enter your password if prompted.</li> </ul>
<b>Step 2</b> <code>configure terminal</code>  <b>Example:</b> <pre>Router# configure terminal</pre>	Enters global configuration mode.
<b>Step 3</b> <code>interface type number</code>  <b>Example:</b> <pre>Router(config)# interface tunnel 100</pre>	Configures an interface and enters interface configuration mode.
<b>Step 4</b> <code>ip nhrp use usage-count</code>  <b>Example:</b> <pre>Router(config-if)# ip nhrp use 5</pre>	Specifies how many data packets are sent to a destination before NHRP is attempted. <ul style="list-style-type: none"> <li>In this example, if in the first minute five packets are sent to the first destination and five packets are sent to a second destination, then a single NHRP request is generated for the second destination.</li> <li>If in the second minute the same traffic is generated and no NHRP responses have been received, then the system resends its request for the second destination.</li> </ul>

## Triggering NHRP Based on Traffic Thresholds

NHRP can run on Cisco Express Forwarding platforms when NHRP runs with Border Gateway Protocol (BGP). You can configure NHRP to initiate SVCs once a configured traffic rate is reached. Similarly, SVCs can be torn down when traffic falls to another configured rate.

You can configure the traffic rate that must be reached before NHRP sets up or tears down an SVC. Because SVCs are created only for burst traffic, you can conserve resources.

To configure the NHRP triggering and teardown of SVCs based on traffic rate, perform the following tasks. The first task is required; the second and third tasks are optional.

- [Changing the Rate for Triggering SVCs, page 20](#)
- [Changing the Sampling Time Period and Sampling Rate, page 22](#)
- [Applying the Triggering and Teardown Rates to Specific Destinations, page 23](#)

### Changing the Rate for Triggering SVCs



Perform this task to change the number of kilobits per second (kbps) at which NHRP sets up or tears down the SVC to this destination.

When NHRP runs with BGP, there is a way to control the triggering of NHRP packets. This method consists of SVCs being initiated based on the input traffic rate to a given BGP next hop.

When BGP discovers a BGP next hop and enters this BGP route into the routing table, an NHRP request is sent to the BGP next hop. When an NHRP reply is received, a subsequent route is put in the NHRP cache that directly corresponds to the BGP next hop.

A new NHRP request is sent to the same BGP next hop to repopulate the NHRP cache. When an NHRP cache entry is generated, a subsequent map statement to the same BGP next hop is also created.

Aggregate traffic to each BGP next hop is measured and monitored. Once the aggregate traffic has met or exceeded the configured trigger rate, NHRP creates an SVC and sends traffic directly to that destination router. The router tears down the SVC to the specified destinations when the aggregate traffic rate falls to or below the configured teardown rate.

By default, NHRP will set up an SVC for a destination when aggregate traffic for that destination is more than 1 kbps over a running average of 30 seconds. Similarly, NHRP will tear down the SVC when the traffic for that destination drops to 0 kbps over a running average of 30 seconds. There are several ways to change the rate at which SVC setup or teardown occurs. You can change the number of kbps thresholds, or the load interval, or both.

Before you configure the feature whereby NHRP initiation is based on traffic rate, the following conditions must exist in the router:

- GRE must be configured.
- CEF switching or distributed CEF (dCEF) switching must be enabled.
- BGP must be configured on all routers in the network where these enhancements are running.

If your network has CEF switching or dCEF switching and you want NHRP to work (whether with default values or changed values), configure the **ip cef accounting non-recursive** command.

**SUMMARY STEPS**

1. **enable**
2. **configure terminal**
3. **interface** *type number*
4. **ip nhrp trigger-svc** *trigger-threshold teardown-threshold*

**DETAILED STEPS**

Command or Action	Purpose
<p><b>Step 1</b> <b>enable</b></p> <p><b>Example:</b></p> <pre>Router&gt; enable</pre>	<p>Enables privileged EXEC mode.</p> <ul style="list-style-type: none"> <li>• Enter your password if prompted.</li> </ul>

Command or Action	Purpose
<b>Step 2</b> <code>configure terminal</code>  <b>Example:</b> <pre>Router# configure terminal</pre>	Enters global configuration mode.
<b>Step 3</b> <code>interface type number</code>  <b>Example:</b> <pre>Router(config)# interface tunnel 100</pre>	Configures an interface and enters interface configuration mode.
<b>Step 4</b> <code>ip nhrp trigger-svc trigger-threshold teardown-threshold</code>  <b>Example:</b> <pre>Router(config-if)# ip nhrp trigger-svc 100 5</pre>	Changes the rate at which NHRP sets up or tears down SVCs. <ul style="list-style-type: none"> <li>In this example, the triggering and teardown thresholds are set to 100 kbps and 5 kbps, respectively.</li> </ul>

## Changing the Sampling Time Period and Sampling Rate

You can change the length of time over which the average trigger rate or teardown rate is calculated. By default, the period is 30 seconds; the range is from 30 to 300 seconds in 30-second increments. This period is for calculations of aggregate traffic rate internal to Cisco IOS XE software only, and it represents a worst-case time period for taking action. In some cases, the software will act sooner, depending on the ramp-up and fall-off rate of the traffic.

If your Cisco hardware has a Virtual Interface Processor, version 2 adapter, you must perform this task to change the sampling time. By default, the port adapter sends the traffic statistics to the Route Processor every 10 seconds. If you are using NHRP in dCEF switching mode, you must change this update rate to 5 seconds.

Perform this task to change the sampling time period and the sampling rate.

### SUMMARY STEPS

1. `enable`
2. `configure terminal`
3. `ip cef traffic-statistics [load-interval seconds]`
4. `ip cef traffic-statistics [update-rate seconds]`

## DETAILED STEPS

Command or Action	Purpose
<p><b>Step 1</b> <code>enable</code></p> <p><b>Example:</b></p> <pre>Router&gt; enable</pre>	<p>Enables privileged EXEC mode.</p> <ul style="list-style-type: none"> <li>Enter your password if prompted.</li> </ul>
<p><b>Step 2</b> <code>configure terminal</code></p> <p><b>Example:</b></p> <pre>Router# configure terminal</pre>	<p>Enters global configuration mode.</p>
<p><b>Step 3</b> <code>ip cef traffic-statistics [load-interval <i>seconds</i>]</code></p> <p><b>Example:</b></p> <pre>Router(config)# ip cef traffic-statistics load-interval 120</pre>	<p>Changes the length of time in a sampling period during which trigger and teardown thresholds are averaged.</p> <ul style="list-style-type: none"> <li>In this example, the triggering and teardown thresholds are calculated based on an average over 120 seconds.</li> </ul>
<p><b>Step 4</b> <code>ip cef traffic-statistics [update-rate <i>seconds</i>]</code></p> <p><b>Example:</b></p> <pre>Router(config)# ip cef traffic-statistics update-rate 5</pre>	<p>Specifies the frequency that the port adapter sends the accounting statistics to the RP.</p> <ul style="list-style-type: none"> <li>When using NHRP in distributed CEF switching mode, this value must be set to 5 seconds. The default value is 10 seconds.</li> </ul>

## Applying the Triggering and Teardown Rates to Specific Destinations

Perform this task to impose the triggering and teardown rates on certain destinations. By default, all destinations are measured and monitored for NHRP triggering.

## SUMMARY STEPS

- `enable`
- `configure terminal`
- Do one of the following:
  - `access-list access-list-number {deny | permit} source[source-wildcard]`
  - `access-list access-list-number {deny | permit} protocol source source-wildcard destination destination-wildcard[precedence precedence] [tos tos] [log]`
- `interface type number`
- `ip nhrp interest access-list-number`

## DETAILED STEPS

Command or Action	Purpose
<p><b>Step 1</b> <code>enable</code></p> <p><b>Example:</b></p> <pre>Router&gt; enable</pre>	<p>Enables privileged EXEC mode.</p> <ul style="list-style-type: none"> <li>Enter your password if prompted.</li> </ul>
<p><b>Step 2</b> <code>configure terminal</code></p> <p><b>Example:</b></p> <pre>Router# configure terminal</pre>	<p>Enters global configuration mode.</p>
<p><b>Step 3</b> Do one of the following:</p> <ul style="list-style-type: none"> <li><code>access-list access-list-number {deny   permit} source[source-wildcard]</code></li> <li><code>access-list access-list-number {deny   permit} protocol source source-wildcard destination destination-wildcard[precedence precedence] [tos tos] [log]</code></li> </ul> <p><b>Example:</b></p> <pre>Router(config)# access-list 101 permit ip any any</pre> <p><b>Example:</b></p> <pre>Router(config)# access-list 101 deny ip any 10.3.0.0 0.0.255.255</pre>	<p>Defines a standard or extended IP access list.</p> <ul style="list-style-type: none"> <li>In the example an extended access list is defined.</li> </ul>
<p><b>Step 4</b> <code>interface type number</code></p> <p><b>Example:</b></p> <pre>Router(config)# interface tunnel 100</pre>	<p>Configures an interface and enters interface configuration mode.</p>
<p><b>Step 5</b> <code>ip nhrp interest access-list-number</code></p> <p><b>Example:</b></p> <pre>Router(config-if)# ip nhrp interest 101</pre>	<p>Specifies an IP access list that controls NHRP requests.</p> <ul style="list-style-type: none"> <li>In this example, only the packets that pass extended access list 101 are subject to the default SVC triggering and teardown rates.</li> </ul>

## Controlling the NHRP Packet Rate

Perform this task to change the maximum rate at which NRHP packets will be handled.

There is the maximum value (max-send interval) for the number of NHRP messages that the local NHRP process can handle within a set period of time. This limit protects the router against events like a runaway NHRP process sending NHRP requests or an application (worm) that is doing an IP address scan that is triggering many spoke-to-spoke tunnels.

The larger the max-send interval the more NHRP packets the system can process and send. These messages do not use much memory and the CPU usage is not very large per message; however, excessive messages causing excessive CPU usage can degrade system performance.

To set a reasonable max-send-interval, consider the following information:

- Number of spoke routers being handled by this hub and how often they send NHRP registration requests. To support this load you would need:

Number of spokes/registration timeout \* max-send interval

For example, 500 spokes with a 100-second registration timeout would equate as follows:

$$\text{max-send interval} = 500/100 * 10 = 50$$

- The maximum number of spoke-to-spoke tunnels that are expected to be up at any one time across the NBMA network:

spoke-to-spoke tunnels/NHRP holdtime \* max-send interval

This would cover spoke-to-spoke tunnel creation and the refreshing of spoke-to-spoke tunnels that are used for longer periods of time.

Then add these values together and multiply the result by 1.5 or 2.0 to give a buffer.

- The max-send interval can be used to keep the long-term average number of NHRP messages allowed to be sent constant, but allow greater peaks.

By default, the maximum rate at which the software sends NHRP packets is five packets per 10 seconds. The software maintains a per-interface quota of NHRP packets (whether generated locally or forwarded) that can be sent.

**SUMMARY STEPS**

1. enable
2. configure terminal
3. interface *type number*
4. ip nhrp max-send *pkt-count every interval*

**DETAILED STEPS**

Command or Action	Purpose
<p><b>Step 1</b> enable</p> <p><b>Example:</b></p> <pre>Router&gt; enable</pre>	<p>Enables privileged EXEC mode.</p> <ul style="list-style-type: none"> <li>• Enter your password if prompted.</li> </ul>

Command or Action	Purpose
<b>Step 2</b> <code>configure terminal</code>  <b>Example:</b> <pre>Router# configure terminal</pre>	Enters global configuration mode.
<b>Step 3</b> <code>interface type number</code>  <b>Example:</b> <pre>Router(config)# interface tunnel 100</pre>	Configures an interface and enters interface configuration mode.
<b>Step 4</b> <code>ip nhrp max-send pkt-count every interval</code>  <b>Example:</b> <pre>Router(config-if)# ip nhrp max-send 10 every 10</pre>	In this example, ten NHRP packets can be sent from the interface every 10 seconds (twice the default rate).

## Suppressing Forward and Reverse Record Options

To dynamically detect link layer filtering in NBMA networks (for example, SMDS address screens), and to provide loop detection and diagnostic capabilities, NHRP incorporates a Route Record in request and reply packets. The Route Record options contain the network (and link layer) addresses of all intermediate Next Hop Servers between the source and destination (in the forward direction) and between the destination and source (in the reverse direction).

By default, Forward Record options and Reverse Record options are included in NHRP request and reply packets. Perform this task to suppress forward and reverse record options.



### Note

Forward and Reverse Record information is required for the proper operation of NHRP, especially in a DMVPN network. Therefore you must not configure suppression of this information.

### SUMMARY STEPS

1. `enable`
2. `configure terminal`
3. `interface type number`
4. `no ip nhrp record`

## DETAILED STEPS

	Command or Action	Purpose
Step 1	<b>enable</b>  <b>Example:</b> Router> enable	Enables privileged EXEC mode. <ul style="list-style-type: none"> <li>Enter your password if prompted.</li> </ul>
Step 2	<b>configure terminal</b>  <b>Example:</b> Router# configure terminal	Enters global configuration mode.
Step 3	<b>interface <i>type number</i></b>  <b>Example:</b> Router(config)# interface tunnel 100	Configures an interface and enters interface configuration mode.
Step 4	<b>no ip nhrp record</b>  <b>Example:</b> Router(config-if)# no ip nhrp record	Suppresses Forward and Reverse Record options.

## Specifying the NHRP Responder IP Address

An NHRP requester that wants to know which Next Hop Server generates an NHRP reply packet can include the responder address option in its NHRP request packet. The Next Hop Server that generates the NHRP reply packet then complies by inserting its own IP address in the NHRP reply. The Next Hop Server uses the primary IP address of the specified interface.

Perform this task to specify which interface the Next Hop Server uses for the NHRP responder IP address.

### SUMMARY STEPS

1. **enable**
2. **configure terminal**
3. **interface *type number***
4. **ip nhrp responder *type number***

## DETAILED STEPS

Command or Action	Purpose
<p><b>Step 1</b> <code>enable</code></p> <p><b>Example:</b></p> <pre>Router&gt; enable</pre>	<p>Enables privileged EXEC mode.</p> <ul style="list-style-type: none"> <li>Enter your password if prompted.</li> </ul>
<p><b>Step 2</b> <code>configure terminal</code></p> <p><b>Example:</b></p> <pre>Router# configure terminal</pre>	<p>Enters global configuration mode.</p>
<p><b>Step 3</b> <code>interface type number</code></p> <p><b>Example:</b></p> <pre>Router(config)# interface serial 0</pre>	<p>Configures a serial interface and enters interface configuration mode.</p>
<p><b>Step 4</b> <code>ip nhrp responder type number</code></p> <p><b>Example:</b></p> <pre>Router(config-if)# ip nhrp responder serial 0</pre>	<p>Specifies which interface the Next Hop Server uses for the NHRP responder IP address.</p> <ul style="list-style-type: none"> <li>In this example, any NHRP requests for the Responder Address will cause this router acting as a next-hop server to supply the primary IP address of serial interface 0 in the NHRP reply packet.</li> <li>If an NHRP reply packet being forwarded by a Next Hop Server contains the IP address of that server, the Next Hop Server generates an error indication of type “NHRP Loop Detected” and discards the reply.</li> </ul>

## Clearing the NHRP Cache

The NHRP cache can contain entries of statically configured NHRP mappings and dynamic entries caused by the Cisco IOS XE software learning addresses from NHRP packets. To clear statically configured entries, use the **no ip nhrp map** command in interface configuration mode.

Perform the following task to clear the NHRP cache.

### SUMMARY STEPS

- `enable`
- `clear ip nhrp [ip-address] [ip-mask]`



## DETAILED STEPS

Command or Action	Purpose
<b>Step 1</b> <code>enable</code>  <b>Example:</b>  <pre>Router&gt; enable</pre>	Enables privileged EXEC mode. <ul style="list-style-type: none"> <li>• Enter your password if prompted.</li> </ul>
<b>Step 2</b> <code>clear ip nhrp [ip-address] [ip-mask]</code>  <b>Example:</b>  <pre>Router# clear ip nhrp</pre>	Clears the IP NHRP cache of dynamic entries. <ul style="list-style-type: none"> <li>• This command does not clear any static (configured) IP to NBMA address mappings from the NHRP cache.</li> </ul>

## Configuration Examples for NHRP

- [Physical Network Designs for Logical NBMA Examples, page 29](#)
- [Applying NHRP Rates to Specific Destinations Example, page 31](#)
- [NHRP on a Multipoint Tunnel Example, page 32](#)
- [Show NHRP Examples, page 32](#)

## Physical Network Designs for Logical NBMA Examples

A logical NBMA network is considered the group of interfaces and hosts participating in NHRP and having the same network identifier. The figure below illustrates two logical NBMA networks (shown as circles) configured over a single physical NBMA network. Router A can communicate with routers B and C because they share network identifier (2). Router C can also communicate with routers D and E because

they share network identifier 7. After address resolution is complete, router A can send IP packets to router C in one hop, and router C can send them to router E in one hop, as shown by the dotted lines.

**Figure 2** Two Logical NBMA Networks over One Physical NBMA Network

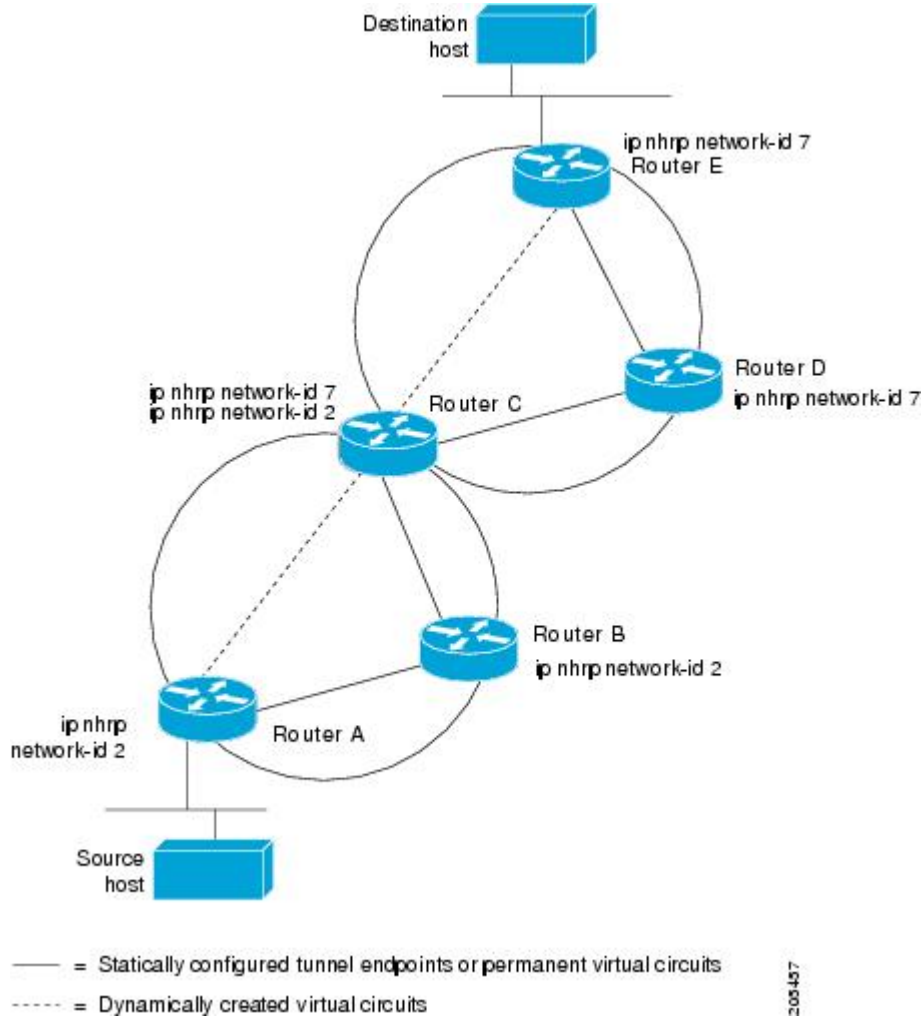

The physical configuration of the five routers in the figure above might actually be that shown in the figure below. The source host is connected to router A and the destination host is connected to router E. The same switch serves all five routers, making one physical NBMA network.

**Figure 3** Physical Configuration of a Sample NBMA Network

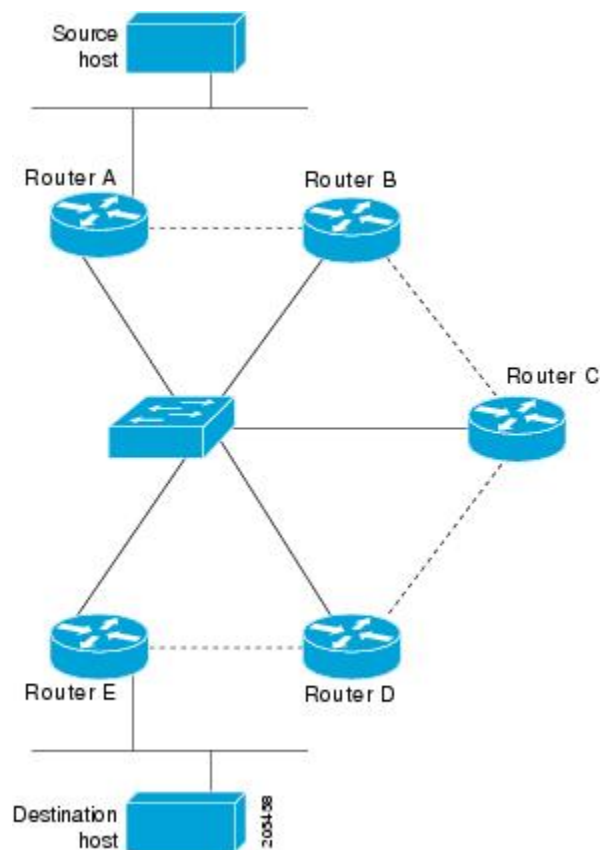

Refer again to the first figure above. Initially, before NHRP has resolved any NBMA addresses, IP packets from the source host to the destination host travel through all five routers connected to the switch before reaching the destination. When router A first forwards the IP packet toward the destination host, router A also generates an NHRP request for the IP address of the destination host. The request is forwarded to router C, whereupon a reply is generated. Router C replies because it is the egress router between the two logical NBMA networks.

Similarly, router C generates an NHRP request of its own, to which router E replies. In this example, subsequent IP traffic between the source and the destination still requires two hops to traverse the NBMA network, because the IP traffic must be forwarded between the two logical NBMA networks. Only one hop would be required if the NBMA network were not logically divided.

## Applying NHRP Rates to Specific Destinations Example

In the following example, only the packets that pass extended access list 101 are subject to the default SVC triggering and teardown rates:

```
interface tunnel 100
 ip nhrp interest 101
```

```

!
access-list 101 permit ip any any
access-list 101 deny ip any 10.3.0.0 0.0.255.255

```

## NHRP on a Multipoint Tunnel Example

With multipoint tunnels, a single tunnel interface may be connected to multiple neighboring routers. Unlike point-to-point tunnels, a tunnel destination need not be configured. In fact, if configured, the tunnel destination must correspond to an IP multicast address. Broadcast or multicast packets to be sent over the tunnel interface can then be sent by sending the GRE packet to the multicast address configured as the tunnel destination.

Multipoint tunnels require that you configure a tunnel key. Otherwise, unexpected GRE traffic could easily be received by the tunnel interface. For simplicity, we recommend that the tunnel key correspond to the NHRP network identifier.

In the following example, routers A and B share a GigabitEthernet segment. Minimal connectivity over the multipoint tunnel network is configured, thus creating a network that can be treated as a partially meshed NBMA network.

The significant portions of the configurations for routers A and B follow:

### Router A Configuration

```

interface tunnel 1
 ip address 10.1.1.1 255.255.255.0
 no ip redirects
 ip nhrp authentication cisco
 ip nhrp map multicast dynamic
 ip nhrp network-id 123
 no ip split-horizon eigrp 100
 tunnel source GigabitEthernet 0/0/7
 tunnel mode gre multipoint
 tunnel key 123
 tunnel protection ipsec profile DMVPN
 interface GigabitEthernet 0/0/7
 ip address 10.1.2.1 255.255.255.0

```

### Router B Configuration

```

interface tunnel 1
 ip address 10.1.1.2 255.255.255.0
 no ip redirects
 ip nhrp authentication cisco
 ip nhrp map multicast dynamic
 ip nhrp map multicast 10.1.2.1
 ip nhrp map 10.1.1.1 10.1.2.1
 ip nhrp network-id 123
 ip nhrp nhs 10.1.1.1
 tunnel source GigabitEthernet 0/1
 tunnel mode gre multipoint
 tunnel key 123
 tunnel protection ipsec profile DMVPN
 interface GigabitEthernet 0/1
 ip address 10.1.2.2 255.255.255.0

```

## Show NHRP Examples

The following is sample output from the **show ip nhrp** command:

```
Router# show ip nhrp
```

```

10.1.1.2/32 via 10.1.1.2, Tunnel1 created created 22:59:16, expire 01:35:31
  Type: dynamic, Flags: unique registered
  NBMA address: 10.1.2.2
10.1.1.3/32 via 10.1.1.3, Tunnel1 created 21:59:16, expire 01:20:44
  Type: dynamic, Flags: unique registered
  NBMA address: 10.1.1.2

```

The fields in the sample display are as follows:

- The IP address and its network mask in the IP-to-NBMA address cache. The mask is always 255.255.255.255 (/32) because Cisco does not support aggregation of NBMA information through NHRP.
- The interface type and number and how long ago it was created (hours:minutes:seconds).
- The time in which the positive and negative authoritative NBMA address will expire (hours:minutes:seconds). This value is based on the **ip nhrp holdtime** command.
- Type of interface:
  - dynamic--NBMA address was obtained from the NHRP Request packet.
  - static--NBMA address was statically configured.
- Flags:
  - authoritative--Indicates that the NHRP information was obtained from the Next Hop Server or router that maintains the NBMA-to-IP address mapping for a particular destination.
  - implicit--Indicates that the information was learned from the source mapping information of an NHRP resolution request received by the local router, or from an NHRP resolution packet being forwarded through the local router.
  - negative--For negative caching; indicates that the requested NBMA mapping could not be obtained.
  - unique--Indicates that this NHRP mapping entry must be unique; it cannot be overwritten with a mapping entry that has the same IP address but a different NBMA address.
  - registered--Indicates the NHRP mapping entry was created by an NHRP registration request.
  - used--Indicates the NHRP mapping was used to forward data packets within the last 60 seconds.
  - router--Indicates an NHRP mapping entry that is from a remote router that is providing access to a network or host behind the remote router.
  - local--Indicates an NHRP mapping entry for networks local to this router for which this router has answered an NHRP resolution request.
  - (no socket)--Indicates an NHRP mapping entry for which IPsec socket (for encryption) has not been triggered. These mapping entries are not used to forward data packets.
  - nat--Indicates an NHRP mapping entry for which IPsec socket (for encryption) has not been triggered. These mapping entries are not used to forward data packets.
  - NBMA address--Nonbroadcast multiaccess address. The address format is appropriate for the type of network being used (for example, GRE, Ethernet, SMDS, or multipoint tunnel)

The following example shows output for a specific tunnel, tunnel7:

#### Router# show ip nhrp traffic interface tunnel0

```

Tunnel0: Max-send limit:100Pkts/10Sec, Usage:0%
  Sent: Total 79
        18 Resolution Request  10 Resolution Reply  42 Registration Request
         0 Registration Reply  3 Purge Request  6 Purge Reply
         0 Error Indication  0 Traffic Indication
  Rcvd: Total 69
        10 Resolution Request  15 Resolution Reply  0 Registration Request

```

```

36 Registration Reply  6 Purge Request  2 Purge Reply
0 Error Indication  0 Traffic Indication

```

The fields shown in the sample display are as follows:

- Tunnel0--Interface type and number.
- Max-send limit--Maximum number of NHRP messages that can be sent by this station in the given interval.
- Resolution Request--Number of NHRP resolution request packets originated from or received by this station.
- Resolution Reply--Number of NHRP resolution reply packets originated from or received by this station.
- Registration Request--Number of NHRP resolution reply packets originated from or received by this station.
- Registration Reply--Number of NHRP registration reply packets originated from or received by this station.
- Purge Request--Number of NHRP reply packets received by this station.
- Purge Reply--Number of NHRP register packets originated from this station. Routers and access servers do not send register packets, so this value is 0.
- Error Indication--Number of NHRP error packets originated from or received by this station.
- Traffic Indication--Number of NHRP traffic indication packets (redirects) originated or received from this station.

## Additional References

The following sections provide references related to configuring NHRP.

### Related Documents

Related Topic	Document Title
The DMVPN feature allows users to better scale large and small IP Security (IPsec) Virtual Private Networks (VPNs) by combining generic routing encapsulation (GRE) tunnels, IPsec encryption, and Next Hop Resolution Protocol (NHRP).	“Dynamic Multipoint VPN” module
NRHP commands	<i>Cisco IOS IP Addressing Services Command Reference</i>

### RFCs

RFC	Title
RFC 2332	NBMA Next Hop Resolution Protocol (NHRP)

### Technical Assistance

Description	Link
<p>The Cisco Support website provides extensive online resources, including documentation and tools for troubleshooting and resolving technical issues with Cisco products and technologies.</p> <p>To receive security and technical information about your products, you can subscribe to various services, such as the Product Alert Tool (accessed from Field Notices), the Cisco Technical Services Newsletter, and Really Simple Syndication (RSS) Feeds.</p> <p>Access to most tools on the Cisco Support website requires a Cisco.com user ID and password.</p>	<p><a href="http://www.cisco.com/techsupport">http://www.cisco.com/techsupport</a></p>

## Feature Information for Configuring NHRP

The following table provides release information about the feature or features described in this module. This table lists only the software release that introduced support for a given feature in a given software release train. Unless noted otherwise, subsequent releases of that software release train also support that feature.

Use Cisco Feature Navigator to find information about platform support and Cisco software image support. To access Cisco Feature Navigator, go to [www.cisco.com/go/cfn](http://www.cisco.com/go/cfn). An account on Cisco.com is not required.

**Table 1**      **Feature Information for NHRP**

Feature Name	Releases	Feature Configuration Information
Next Hop Resolution Protocol	Cisco IOS XE Release 2.1	<p>NHRP is an Address Resolution Protocol (ARP)-like protocol that dynamically maps an NBMA network. With NHRP, systems attached to an NBMA network can dynamically learn the NBMA (physical) address of the other systems that are part of that network, allowing these systems to directly communicate.</p> <p>NHRP is a client and server protocol where the hub is the Next Hop Server (NHS) and the spokes are the Next Hop Clients (NHCs). The hub maintains an NHRP database of the public interface addresses of each spoke. Each spoke registers its real address when it boots and queries the NHRP database for real addresses of the destination spokes to build direct tunnels.</p>

Cisco and the Cisco logo are trademarks or registered trademarks of Cisco and/or its affiliates in the U.S. and other countries. To view a list of Cisco trademarks, go to this URL: [www.cisco.com/go/trademarks](http://www.cisco.com/go/trademarks). Third-party trademarks mentioned are the property of their respective owners. The use of the word partner does not imply a partnership relationship between Cisco and any other company. (1110R)

Any Internet Protocol (IP) addresses and phone numbers used in this document are not intended to be actual addresses and phone numbers. Any examples, command display output, network topology diagrams, and other figures included in the document are shown for illustrative purposes only. Any use of actual IP addresses or phone numbers in illustrative content is unintentional and coincidental.





# Shortcut Switching Enhancements for NHRP in DMVPN Networks

Routers in a Dynamic Multipoint VPN (DMVPN) Phase 3 network use Next Hop Resolution Protocol (NHRP) Shortcut Switching to discover shorter paths to a destination network after receiving an NHRP redirect message from the hub. This allows the routers to communicate directly with each other without the need for an intermediate hop.

- [Finding Feature Information, page 37](#)
- [Information About Shortcut Switching Enhancements for NHRP , page 37](#)
- [How to Configure Shortcut Switching for NHRP, page 40](#)
- [Configuration Examples for Shortcut Switching Enhancements for NHRP, page 43](#)
- [Additional References, page 47](#)
- [Feature Information for Shortcut Switching Enhancements for NHRP in DMVPN Networks, page 48](#)

## Finding Feature Information

Your software release may not support all the features documented in this module. For the latest feature information and caveats, see the release notes for your platform and software release. To find information about the features documented in this module, and to see a list of the releases in which each feature is supported, see the Feature Information Table at the end of this document.

Use Cisco Feature Navigator to find information about platform support and Cisco software image support. To access Cisco Feature Navigator, go to [www.cisco.com/go/cfn](http://www.cisco.com/go/cfn). An account on Cisco.com is not required.

## Information About Shortcut Switching Enhancements for NHRP

- [DMVPN Phase 3 Networks Overview, page 38](#)
- [Benefits of NHRP Shortcut Switching Enhancements, page 38](#)
- [NHRP as a Route Source, page 39](#)
- [Next Hop Overrides, page 40](#)
- [NHRP Route Watch Infrastructure, page 40](#)
- [NHRP Purge Request Reply, page 40](#)

## DMVPN Phase 3 Networks Overview

In a DMVPN Phase 3 network, separate regional DMVPN networks are connected together into a single hierarchical DMVPN network. Spokes in different regions use NHRP to build direct spoke-to-spoke tunnels with each other, bypassing both the regional and the central hubs. When building spoke-to-spoke tunnels within a region, only the regional hubs are involved in the tunnel setup. When building spoke-to-spoke tunnels between regions, the regional and the central hubs are involved in the tunnel setup.

DMVPN Phase 3 provides improvements over a DMVPN Phase 2 network. For a DMVPN spoke-to-spoke network, the main improvements from Phase 2 are in the increased flexibility in laying out the base DMVPN network. DMVPN Phase 3 allows a hierarchical hub design whereas DMVPN Phase 2 relies on “daisy-chaining” of hubs for scaling the network. DMVPN Phase 3 also removes some of the restrictions on the routing protocols required by Phase 2 (OSPF broadcast mode and non split-tunneling). DMVPN Phase 3 is not expected to change the number of spokes that a single DMVPN hub can support but it may reduce the CPU load of the routing protocol on the hub.

## Benefits of NHRP Shortcut Switching Enhancements

Cisco has developed NHRP shortcut switching model enhancements that allow for more scalable DMVPN implementations. This model provides the following benefits:

- Allows summarization of routing protocol updates from hub to spokes. The spokes no longer need to have an individual route with an IP next hop of the tunnel IP address of the remote spoke for the networks behind all the other spokes. The spoke can use summarized routes with an IP next hop of the tunnel IP address of the hub and still be able to build spoke-to-spoke tunnels. It can reduce the load on the routing protocol running on the hub router. You can reduce the load because, when you can summarize the networks behind the spokes to a few summary routes or even one summary route, the hub routing protocol only has to advertise the few or one summary route to each spoke rather than all of the individual spoke routes. For example, with 1000 spokes and one router per spoke, the hub receives 1000 routes but only has to advertise one summary route to each spoke (equivalent to 1000 advertisements, one per spoke) instead of the 1,000,000 advertisements it had to process in the prior implementation of DMVPN.
- Provides better alternatives to static daisy-chaining of hubs for expanding DMVPN spoke-to-spoke networks. The hubs must still be interconnected, but they are not restricted to just a daisy-chain pattern. The routing table is used to forward data packets and NHRP control packets between the hubs. The routing table allows efficient forwarding of packets to the correct hub rather than having request and reply packets traversing through all of the hub routers.
- Allows for expansion of DMVPN spoke-to-spoke networks with OSPF as the routing protocol beyond two hubs. Because the spokes can use routes with the IP next-hop set to the hub router (not the remote spoke router as before), you can configure OSPF to use point-multipoint network mode rather than broadcast network mode. Configuring OSPF to use point-multipoint network mode removes the DR and BDR requirements that restricted the DMVPN network to just two hubs. When using OSPF, each spoke still has all individual routes, because the DMVPN network must be in a single OSPF area but you cannot summarize routes within an OSPF area.
- Allows routing protocols such as ODR to be used and still retain the ability to build dynamic spoke-to-spoke tunnels.
- Allows for hierarchical (greater than one level) and more complex tree-based DMVPN network topologies. Tree-based topologies allow the capability to build DMVPN networks with regional hubs that are spokes of central hubs. This architecture allows the regional hub to handle the data and NHRP control traffic for its regional spokes, but still allows spoke-to-spoke tunnels to be built between any spokes within the DMVPN network, whether they are in the same region or not.

- Enables the use of Cisco Express Forwarding to switch data packets along the routed path until a spoke-to-spoke tunnel is established.

## NHRP as a Route Source

To implement shortcut switching, NHRP works as a route source and installs shortcut paths, as NHRP routes, directly into the Routing Information Base (RIB). This means that shortcut paths appear as routes in the routing table and NHRP works in lieu of the routing protocol (for example, RIP, OSPF or EIGRP). The shortcut routes in the RIB are distributed into the Forwarding Information Base (FIB). When a spoke discovers a shortcut path, it adds the path as an NHRP route to its routing table. The RIB and FIB have no special behaviour for shortcut switching and shortcut routes are treated like any other route.

NHRP acts as a route producer to the RIB, but it does not function as a full routing protocol. NHRP manages the route registration, resolution, and purge messages but it does not discover or maintain NHRP neighbors, advertise NHRP routing messages, or inform the network of any network topology changes.

Consider Spoke A in the figure below. It discovers a shortcut path to N2 via Spoke 2's tunnel (overlay) address TS2. It installs the shortcut path in its NHRP mapping table via the entry N2-PS2 (TS2) and it also adds the route to the RIB. The new route in the RIB is then distributed into the FIB and the FIB installs the corresponding adjacency TS2-PS2 in the adjacency table. The new route TS2-PS2 can now be used for forwarding. Note the consistency between the RIB, the FIB, and the adjacency table.

Figure 4 NHRP As A Route Source

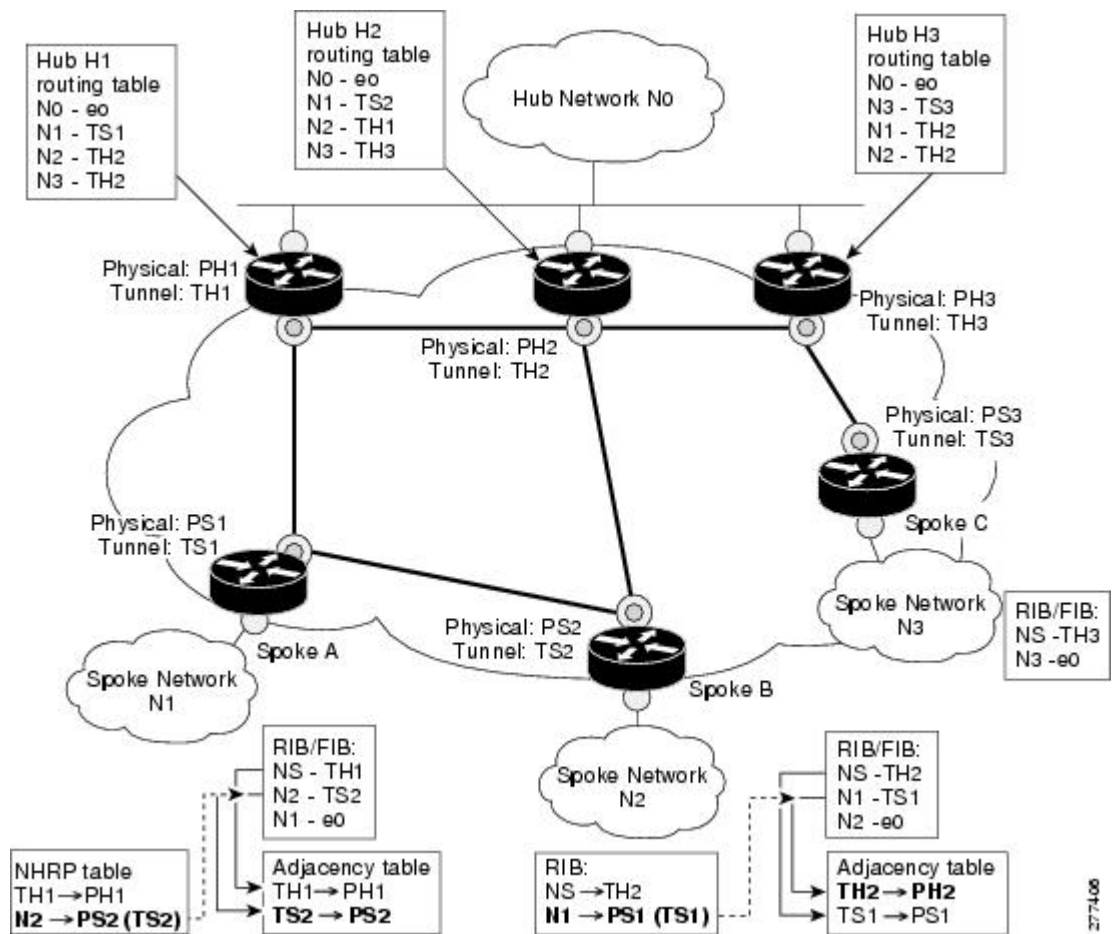

377406

## Next Hop Overrides

If an NHRP route in the RIB is identical to another route (owned by another protocol) in the RIB then NHRP overrides the other protocol's next hop entries by installing shortcut next hops in the RIB. NHRP installs shortcut paths into the routing table, not as NHRP routes but as local forwarding paths. The other routing protocols continue to function as normal managing route redistribution and advertisement. NHRP only overrides local forwarding decisions by installing alternate or backup next hops into the routing table.

## NHRP Route Watch Infrastructure

In a DMVPN full-mesh design, the hub creates summary routes to each of the spokes (Interior Gateway Protocol (IGP) routes). Specific NHRP shortcuts are installed at the spokes by NHRP as and when required. These shortcuts can be viewed as a refinement of the route summaries because they deal with a specific subnet while the summary routes represent super-nets. If the summary route is absent, NHRP cannot discover a shortcut path.

The summary route, or "covering prefix", governs the existence of the NHRP route in the RIB. The removal of a covering prefix in the RIB would lead to the removal of the all the corresponding NHRP routes, that were learnt via this covering prefix, from the RIB. The tracking of covering prefixes is done via the Route Watch infrastructure.

A "watched prefix" is a route that immediately precedes an NHRP route. For example, if an NHRP route is 172.16.3.0/24, then the watch-prefix corresponding to it would be 172.16.2.0/23. Each "watched prefix" and its associated "covering prefixes" are tracked by the Route Watch service. A "covering prefix" is defined as the longest matching IGP route in the RIB which is less specific than the "watched prefix". The validity of each NHRP shortcut is determined by the following events:

- If a "covering prefix" is removed so that there is no other IGP route in the RIB "covering" the watched prefix, (the watched prefix is unreachable), then the corresponding NHRP shortcut route is removed.
- If a new IGP route, which is more specific than the covering prefix but less specific than watched prefix, is installed in RIB, then it will become the covering prefix for the watched prefix. If the new covering prefix has a different next hop associated with it, the original shortcut is removed.

In summary, the validity of an NHRP route in the RIB is determined by the less specific, longest match IGP route present in the RIB. NHRP shortcuts are refinements to the routing topology, so shortcut paths are added to the RIB without modifying the routing topology.

## NHRP Purge Request Reply

When an NHRP hub replies to a resolution request, it creates a local NHRP mapping entry. The local mapping entry is a network entry for which NHRP has sent a reply. The local mapping entry maintains a list of requesters. When a network entry is modified or deleted in the routing table, NHRP is notified of the event. NHRP finds the local cache entry for the network and sends a purge request to the requesters that the network to which it previously replied has changed. The receivers of the purge message delete the corresponding NHRP mapping entry from its table and send a purge reply indicating that the purge message was processed successfully.

# How to Configure Shortcut Switching for NHRP

**Note**

By default shortcut switching on an interface is turned off. If the **ip nhrp shortcut** command is not configured then the DMVPN network will not use shortcut switching.

- [Enabling NHRP Shortcut Switching on an Interface, page 41](#)
- [Clearing NHRP Cache Entries on an Interface, page 42](#)

## Enabling NHRP Shortcut Switching on an Interface

Perform this task to enable shortcut switching for NHRP for an interface on a router.

### SUMMARY STEPS

1. **enable**
2. **configure terminal**
3. **interface** *type number*
4. **ip nhrp shortcut**
5. **end**
6. **show ip nhrp shortcut**
7. **show ip route nhrp**
8. **show ip route next-hop-override**

### DETAILED STEPS

	Command or Action	Purpose
<b>Step 1</b>	<b>enable</b>  <b>Example:</b>  Router> enable	Enables privileged EXEC mode.  • Enter your password if prompted.
<b>Step 2</b>	<b>configure terminal</b>  <b>Example:</b>  Router# configure terminal	Enters global configuration mode.
<b>Step 3</b>	<b>interface</b> <i>type number</i>  <b>Example:</b>  Router(config)# interface Tunnel 0	Enters interface configuration mode.

Command or Action	Purpose
<b>Step 4</b> <code>ip nhrp shortcut</code>  <b>Example:</b> <pre>Router(config-if)# ip nhrp shortcut</pre>	Enables NHRP shortcut switching on an interface.
<b>Step 5</b> <code>end</code>  <b>Example:</b> <pre>Router(config-if)# end</pre>	Ends the configuration session.
<b>Step 6</b> <code>show ip nhrp shortcut</code>  <b>Example:</b> <pre>Router# show ip nhrp shortcut</pre>	(Optional) Displays only the NHRP cache entries that have an NHRP route or an NHRP next-hop override associated with them.
<b>Step 7</b> <code>show ip route nhrp</code>  <b>Example:</b> <pre>Router# show ip route nhrp</pre>	(Optional) Displays the routes added to the routing table by NHRP.
<b>Step 8</b> <code>show ip route next-hop-override</code>  <b>Example:</b> <pre>Router# show ip route next-hop-override</pre>	(Optional) Displays the NHRP next-hop overrides associated with a particular route, along with the corresponding default next hops.

## Clearing NHRP Cache Entries on an Interface

Perform this optional task to clear NHRP cache entries that have associated NHRP routes and next-hop overrides on an interface on a router.

### SUMMARY STEPS

1. `enable`
2. `configure terminal`
3. `clear ip nhrp shortcut interface-name`
4. `end`

## DETAILED STEPS

	Command or Action	Purpose
Step 1	<p><code>enable</code></p> <p><b>Example:</b></p> <pre>Router&gt; enable</pre>	<p>Enables privileged EXEC mode.</p> <ul style="list-style-type: none"> <li>• Enter your password if prompted.</li> </ul>
Step 2	<p><code>configure terminal</code></p> <p><b>Example:</b></p> <pre>Router# configure terminal</pre>	<p>Enters global configuration mode.</p>
Step 3	<p><code>clear ip nhrp shortcut <i>interface-name</i></code></p> <p><b>Example:</b></p> <pre>Router(config)# clear ip nhrp shortcut Tunnel0</pre>	<p>Clears NHRP cache entries on an interface.</p>
Step 4	<p><code>end</code></p> <p><b>Example:</b></p> <pre>Router(config)# end</pre>	<p>Ends the configuration session.</p>

## Configuration Examples for Shortcut Switching Enhancements for NHRP

- [Configuring NHRP Shortcut Switching Example, page 43](#)

### Configuring NHRP Shortcut Switching Example

The following example configures NHRP shortcut switching on tunnel interface 1:

```
Router(config)#
interface Tunnel 1
Router(config-if)#
ip nhrp shortcut
```

The following example shows the output of the `show ip route` and `show ip route nhrp` commands. These commands can be used to show the current state of the routing table. NHRP entries are flagged “H”.

```
Router#
show ip route
Codes: C - connected, S - static, R - RIP, M - mobile, B - BGP
```

```

D - EIGRP, EX - EIGRP external, O - OSPF, IA - OSPF inter area
N1 - OSPF NSSA external type 1, N2 - OSPF NSSA external type 2
E1 - OSPF external type 1, E2 - OSPF external type 2
i - IS-IS, su - IS-IS summary, L1 - IS-IS level-1, L2 - IS-IS level-2
ia - IS-IS inter area, * - candidate default, U - per-user static route
o - ODR, P - periodic downloaded static route, H - NHRP
Gateway of last resort is not set
  10.0.0.0/8 is variably subnetted, 3 subnets, 2 masks
C    10.1.1.0/24 is directly connected, Tunnel0
C    172.16.22.0 is directly connected, Ethernet1/0
H    172.16.99.0 [250/1] via 1.1.1.99, 00:11:43, Tunnel0
    10.2.2.0/24 is subnetted, 1 subnets
C    10.11.11.0 is directly connected, Ethernet0/0
Router#
show ip route nhrp
H    172.16.99.0 [250/1] via 10.1.1.99, 00:11:43, Tunnel0

```

The following sample output displays the NHRP next-hop overrides associated with a particular route and the corresponding default next hops, when the following next-hop override is added:

- IP address: 10.50.10.0
- Mask: 255.255.255.0
- Gateway: 10.1.1.1
- Interface: Tunnel0

```

Router#
show ip route
Codes: L - local, C - connected, S - static, R - RIP, M - mobile, B - BGP
D - EIGRP, EX - EIGRP external, O - OSPF, IA - OSPF inter area
N1 - OSPF NSSA external type 1, N2 - OSPF NSSA external type 2
E1 - OSPF external type 1, E2 - OSPF external type 2
i - IS-IS, su - IS-IS summary, L1 - IS-IS level-1, L2 - IS-IS level-2
ia - IS-IS inter area, * - candidate default, U - per-user static route
o - ODR, P - periodic downloaded static route, H - NHRP
+ - replicated route
Gateway of last resort is not set
  10.0.0.0/8 is variably subnetted, 2 subnets, 2 masks
C    10.2.1.0/24 is directly connected, Loopback1
L    10.2.1.1/32 is directly connected, Loopback1
    10.50.0.0/24 is subnetted, 1 subnets
% S   10.50.10.0 is directly connected, Tunnel0
    10.30.0.0/24 is subnetted, 1 subnets
S    10.30.11.0 is directly connected, Ethernet0/0
Router#
show ip route next-hop-override
Codes: L - local, C - connected, S - static, R - RIP, M - mobile, B - BGP
D - EIGRP, EX - EIGRP external, O - OSPF, IA - OSPF inter area
N1 - OSPF NSSA external type 1, N2 - OSPF NSSA external type 2
E1 - OSPF external type 1, E2 - OSPF external type 2
i - IS-IS, su - IS-IS summary, L1 - IS-IS level-1, L2 - IS-IS level-2
ia - IS-IS inter area, * - candidate default, U - per-user static route
o - ODR, P - periodic downloaded static route, H - NHRP
+ - replicated route
Gateway of last resort is not set
  10.0.0.0/8 is variably subnetted, 2 subnets, 2 masks
C    10.2.1.0/24 is directly connected, Loopback1
L    10.2.1.1/32 is directly connected, Loopback1
    10.50.0.0/24 is subnetted, 1 subnets
% S   10.50.10.0 is directly connected, Tunnel0
        [NHO][1/0] via 10.1.1.1, Tunnel0
    10.30.0.0/24 is subnetted, 1 subnets
S    10.30.11.0 is directly connected, Ethernet0/0
Router#
show ip cef
Prefix                Next Hop                Interface
10.2.1.255/32         receive                 Loopback110.10.10.0/24
10.50.10.0/24         10.1.1.1                Tunnel0
10.30.11.0/24         attached                 Ethernet0/0
127.0.0.0/8          drop

```



The following example displays the output of the **show ip route** and **show ip route next-hop-override** commands after the following next-hop override is deleted:

- IP address: 10.50.10.0
- Mask: 255.255.255.0
- Gateway: 10.1.1.1
- Interface: Tunnel0

```

Router#
show ip route
Codes: L - local, C - connected, S - static, R - RIP, M - mobile, B - BGP
       D - EIGRP, EX - EIGRP external, O - OSPF, IA - OSPF inter area
       N1 - OSPF NSSA external type 1, N2 - OSPF NSSA external type 2
       E1 - OSPF external type 1, E2 - OSPF external type 2
       i - IS-IS, su - IS-IS summary, L1 - IS-IS level-1, L2 - IS-IS level-2
       ia - IS-IS inter area, * - candidate default, U - per-user static route
       o - ODR, P - periodic downloaded static route, H - NHRP
       + - replicated route
Gateway of last resort is not set

    10.0.0.0/8 is variably subnetted, 2 subnets, 2 masks
C       10.2.1.0/24 is directly connected, Loopback1
L       10.2.1.1/32 is directly connected, Loopback1
    10.50.0.0/24 is subnetted, 1 subnets
% S     10.50.10.0 is directly connected, Tunnel0
S       10.30.0.0/24 is subnetted, 1 subnets
S       10.30.11.0 is directly connected, Ethernet0/0
Router#
show ip route next-hop-override
Codes: L - local, C - connected, S - static, R - RIP, M - mobile, B - BGP
       D - EIGRP, EX - EIGRP external, O - OSPF, IA - OSPF inter area
       N1 - OSPF NSSA external type 1, N2 - OSPF NSSA external type 2
       E1 - OSPF external type 1, E2 - OSPF external type 2
       i - IS-IS, su - IS-IS summary, L1 - IS-IS level-1, L2 - IS-IS level-2
       ia - IS-IS inter area, * - candidate default, U - per-user static route
       o - ODR, P - periodic downloaded static route, H - NHRP
       + - replicated route
Gateway of last resort is not set

    10.0.0.0/8 is variably subnetted, 2 subnets, 2 masks
C       10.2.1.0/24 is directly connected, Loopback1
L       10.2.1.1/32 is directly connected, Loopback1
    10.50.0.0/24 is subnetted, 1 subnets
S       10.50.10.0 is directly connected, Tunnel0
S       10.30.0.0/24 is subnetted, 1 subnets
S       10.30.11.0 is directly connected, Ethernet0/0
Router#
show ip cef
Prefix          Next Hop          Interface
10.2.1.1.255/32 receive          Loopback110.10.10.0/24
10.50.10.0/24   attached         Tunnel0
10.30.11.0/24   attached         Ethernet0/0
127.0.0.0/8     drop

```

The following sample output shows the information displayed by the **show ip nhrp** command when a cache entry has an associated NHRP next-hop override in the RIB. Note that the flags for the entry are displayed as “router rib” and not “router candidate”.

```

Router#
show ip nhrp
10.1.1.22/32 via 10.1.1.22
   Tunnel0 created 00:00:06, expire 00:02:23
   Type: dynamic, Flags: router implicit
   NBMA address: 10.11.11.22
10.1.1.99/32 via 10.1.1.99
   Tunnel0 created 4d04h, never expire

```

```

Type: static, Flags: used
NBMA address: 10.11.11.99
172.16.11.0/24 via 10.1.1.11
Tunnel0 created 00:00:06, expire 00:02:23
Type: dynamic, Flags: router unique local
NBMA address: 10.11.11.11
(no-socket)
172.16.22.0/24 via 10.1.1.22
Tunnel0 created 00:00:05, expire 00:02:24
Type: dynamic, Flags: router rib
NBMA address: 10.11.11.22

```

The following example shows the output displayed by the **show ip nhrp** command when a cache entry has an NHRP next-hop override added to the RIB. If the corresponding cache entry has an associated NHRP next-hop override in the RIB, the flags are displayed as “router rib nho”.

```

Router#
show ip nhrp
10.1.1.22/32 via 10.1.1.22
Tunnel0 created 00:00:06, expire 00:02:23
Type: dynamic, Flags: router implicit
NBMA address: 10.11.11.22
10.1.1.99/32 via 10.1.1.99
Tunnel0 created 4d04h, never expire
Type: static, Flags: used
NBMA address: 10.11.11.99
172.16.11.0/24 via 10.1.1.11
Tunnel0 created 00:00:06, expire 00:02:23
Type: dynamic, Flags: router unique local
NBMA address: 10.11.11.11
(no-socket)
172.16.22.0/24 via 10.1.1.22
Tunnel0 created 00:00:05, expire 00:02:24
Type: dynamic, Flags: router rib nho
NBMA address: 10.11.11.22

```

The following example shows the output displayed by the **show ip nhrp shortcut** command. This command displays only the NHRP cache entries that have an associated NHRP route or NHRP next-hop override.

```

Router#
show ip nhrp shortcut
172.16.22.0/24 via 10.1.1.22
Tunnel0 created 00:00:05, expire 00:02:24
Type: dynamic, Flags: router rib
NBMA address: 10.11.11.22
172.16.22.0/24 via 10.1.1.22
Tunnel0 created 00:00:05, expire 00:02:24
Type: dynamic, Flags: router rib nho
NBMA address: 10.11.11.22

```

The following example shows the output displayed by the **show dmvpn** command. The output indicates a route installation in the attributes section of the command output.

```

Router#
show dmvpn
Legend: Attrb --> S - Static, D - Dynamic, I - Incomplete
N - NATed, L - Local, X - No Socket, T1 - Route Installed,
T2 - Nexthop-override
# Ent --> Number of NHRP entries with same NBMA peer
NHS Status: E --> Expecting Replies, R --> Responding
UpDn Time --> Up or Down Time for a Tunnel
=====
Interface: Tunnel0, IPv4 NHRP Details
IPv4 Registration Timer: 60 seconds
IPv4 NHS: 10.1.1.99 RE
Type:Spoke, Total NBMA Peers (v4/v6): 2
# Ent Peer NBMA Addr Peer Tunnel Add State UpDn Tm Attrb Target Network

```

```

-----
2   10.11.11.22      192.1.1.22      UP 00:10:11      D      192.1.1.22/32
0   10.11.11.22      173.1.1.22      UP 00:10:11      DT1    172.16.22.0/24
1   10.11.11.99      173.1.1.99      UP 02:18:29      S      173.1.1.99/32

```

The example shows how to clear NHRP cache entries on tunnel interface 1 that have associated NHRP routes or nexthop overrides:

```
Router(config)# clear ip nhrp shortcut Tunnel1
```

## Additional References

The following sections provide references related to NHRP and DMVPN.

### Related Documents

Related Topic	Document Title
NHRP information and configuration tasks	“Configuring NHRP” module of the <i>Cisco IOS XE IP Addressing Services Configuration Guide</i> .
Cisco IOS commands	<a href="#">Cisco IOS Master Commands List, All Releases</a>
NHRP commands: complete command syntax, command mode, command history, defaults, usage guidelines, and examples	Cisco IOS IP Addressing Services Command Reference
Dynamic Multipoint VPN	“Dynamic Multipoint VPN” module

### Standards

Standard	Title
No new or modified standards are supported by this feature, and support for existing standards has not been modified by this feature.	--

### MIBs

MIB	MIBs Link
None	To locate and download MIBs for selected platforms, Cisco IOS XE software releases, and feature sets, use Cisco MIB Locator found at the following URL: <a href="http://www.cisco.com/go/mibs">http://www.cisco.com/go/mibs</a>

**RFCs**

<b>RFC</b>	<b>Title</b>
None	--

**Technical Assistance**

<b>Description</b>	<b>Link</b>
<p>The Cisco Support website provides extensive online resources, including documentation and tools for troubleshooting and resolving technical issues with Cisco products and technologies.</p> <p>To receive security and technical information about your products, you can subscribe to various services, such as the Product Alert Tool (accessed from Field Notices), the Cisco Technical Services Newsletter, and Really Simple Syndication (RSS) Feeds.</p> <p>Access to most tools on the Cisco Support website requires a Cisco.com user ID and password.</p>	<p><a href="http://www.cisco.com/cisco/web/support/index.html">http://www.cisco.com/cisco/web/support/index.html</a></p>

## Feature Information for Shortcut Switching Enhancements for NHRP in DMVPN Networks

The following table provides release information about the feature or features described in this module. This table lists only the software release that introduced support for a given feature in a given software release train. Unless noted otherwise, subsequent releases of that software release train also support that feature.

Use Cisco Feature Navigator to find information about platform support and Cisco software image support. To access Cisco Feature Navigator, go to [www.cisco.com/go/cfn](http://www.cisco.com/go/cfn). An account on Cisco.com is not required.

**Table 2**      **Feature Information for Shortcut Switching Enhancements for NHRP in DMVPN Networks**

Feature Name	Releases	Feature Information
Next Hop Resolution Protocol (NHRP)-CEF Rewrite for DMVPN Phase 3 Networks.	Cisco IOS XE Release 2.5	<p>Routers in a Dynamic Multipoint VPN (DMVPN) Phase 3 network use Next Hop Resolution Protocol (NHRP) Shortcut Switching to discover shorter paths to a destination network after receiving an NHRP redirect message from the hub. This allows the routers to communicate directly with each other without the need for an intermediate hop.</p> <p>The following commands were introduced or modified: <b>clear ip nhrp shortcut, debug dmvpn, debug nhrp routing, ip nhrp shortcut, show dmvpn, show ip nhrp, show ip nhrp shortcut, show ip route, show ip route next-hop-override.</b></p>

Cisco and the Cisco logo are trademarks or registered trademarks of Cisco and/or its affiliates in the U.S. and other countries. To view a list of Cisco trademarks, go to this URL: [www.cisco.com/go/trademarks](http://www.cisco.com/go/trademarks). Third-party trademarks mentioned are the property of their respective owners. The use of the word partner does not imply a partnership relationship between Cisco and any other company. (1110R)

Any Internet Protocol (IP) addresses and phone numbers used in this document are not intended to be actual addresses and phone numbers. Any examples, command display output, network topology diagrams, and other figures included in the document are shown for illustrative purposes only. Any use of actual IP addresses or phone numbers in illustrative content is unintentional and coincidental.

