



MLDP-Based MVPN

The MLDP-based MVPN feature provides extensions to Label Distribution Protocol (LDP) for the setup of point-to-multipoint (P2MP) and multipoint-to-multipoint (MP2MP) label switched paths (LSPs) for transport in the Multicast Virtual Private Network (MVPN) core network.

- [Finding Feature Information, on page 1](#)
- [Prerequisites for MLDP-Based MVPN, on page 1](#)
- [Restrictions for MLDP-Based MVPN on the RSP2 Module , on page 2](#)
- [Information About MLDP-Based MVPN, on page 2](#)
- [Configuring MLDPv4-Based MVPN, on page 14](#)
- [MLDPv6-Based MVPN, on page 19](#)
- [Configuration Examples for MLDP-Based MVPN, on page 23](#)

Finding Feature Information

Your software release may not support all the features documented in this module. For the latest caveats and feature information, see [Bug Search Tool](#) and the release notes for your platform and software release. To find information about the features documented in this module, and to see a list of the releases in which each feature is supported, see the feature information table.

Use Cisco Feature Navigator to find information about platform support and Cisco software image support. To access Cisco Feature Navigator, go to www.cisco.com/go/cfn. An account on Cisco.com is not required.

Prerequisites for MLDP-Based MVPN

- You must be familiar with IPv4 multicast routing configuration tasks and concepts.
- Cisco Express Forwarding (CEF) must be enabled on the router for label switching.
- Unicast routing must be operational.
- To enable MLDP based multicast VPN, you must configure a VPN routing and forwarding (VRF) instance. For more information about configuring a VRF, see *MPLS Layer 3 VPN Configuration Guide* for your router.

Restrictions for MLDP-Based MVPN on the RSP2 Module

The following restrictions apply to the MLDP-Based MVPN feature on the RSP2 module:

- mLDPv4 extranet is supported from Cisco IOS XE Release 3.17.0S onwards on RSP2 module.
- Route leaking (Leaking the mroutes/traffic from Virtual Routing and Forwarding (VRF) to global table or to between VRFs) for mLDPv4 is supported from Cisco IOS XE Release 3.17.0S onwards.
- MLDP FRR is partially supported (only link level).
- Spanning of mLDP packets in the bud node is *not* supported.
- Bridge domain interfaces (BDI) in the core is *not* supported for mLDPv4 in Cisco IOS XE Release 3.17; Only routed port in the core is supported. Starting with Cisco IOS Release 3.18 and later, MLDPv4 and MLDPv6 with BDI interfaces in core is supported.
- MLDP and Point-to-Multipoint Traffic Engineering (P2MP TE) coexistence is not supported.
- MLDP and MVPN GRE cannot co-exist in the same VRF.
- More than 20 Multicast VRFs (MVRFs) for MLDP is not supported.
- Following multicast groups are not supported:
 - IPv4 on the RSP2 module - more than 2000
 - IPv6 on the RSP2 module - more than 1000
- The **no mpls mldp forwarding recursive** command is required when multiple paths exist .
- Recursive Forwarding Equivalence Class (FEC) is not supported on Rosen MLDP.
- When ip multicast-routing is disabled on bud node, traffic for the downstream tail ends is not be forwarded.
- Routed port-channel, EFP and trunk EFP-based port-channel is not supported as core facing interface on the RSP2 module.

Information About MLDP-Based MVPN

Overview of MLDP-Based MVPN

MVPN allows a service provider to configure and support multicast traffic in an MPLS VPN environment. This feature supports routing and forwarding of multicast packets for each individual VPN routing and forwarding (VRF) instance, and it also provides a mechanism to transport VPN multicast packets across the service provider backbone.

A VPN is network connectivity across a shared infrastructure, such as an Internet service provider (ISP). Its function is to provide the same policies and performance as a private network, at a reduced cost of ownership, thus creating many opportunities for cost savings through operations and infrastructure.

An MVPN allows an enterprise to transparently interconnect its private network across the network backbone of a service provider. The use of an MVPN to interconnect an enterprise network in this way does not change the way that the enterprise network is administered, nor does it change general enterprise connectivity.

As shown in the figure, in an MLDP-based MVPN, a static default multicast distribution tree (MDT) is established for each multicast domain. The default MDT defines the path used by provider edge (PE) devices to send multicast data and control messages to every other PE device in the multicast domain. A default MDT is created in the core network using a single MP2MP LSP. The default MDT behaves like a virtual LAN.

Figure 1: MLDP with the Default MDT Scenario

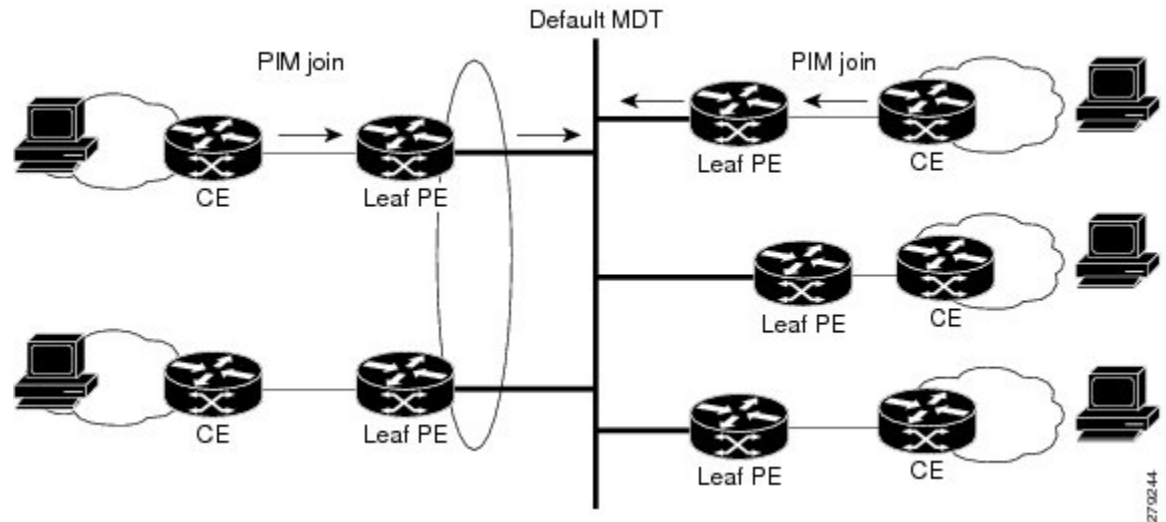

As shown in the figure, an MLDP-based MVPN also supports the dynamic creation of data MDTs for high-bandwidth transmission. For high-rate data sources, a data MDT is created using P2MP LSPs to off-load traffic from the default MDT to avoid unnecessary waste of bandwidth to PEs that did not join the stream. The creation of the data MDT is signaled dynamically using MDT Join TLV messages. Data MDTs are a feature unique to Cisco IOS software. Data MDTs are intended for high-bandwidth sources such as full-motion video inside the VPN to ensure optimal traffic forwarding in the MPLS VPN core. The threshold at which the data MDT is created can be configured on a per-device or a per-VRF basis. When the multicast transmission exceeds the defined threshold, the sending PE device creates the data MDT and sends a User Datagram Protocol (UDP) message, which contains information about the data MDT to all devices on the default MDT.

Figure 2: MLDP with the Data MDT Scenario

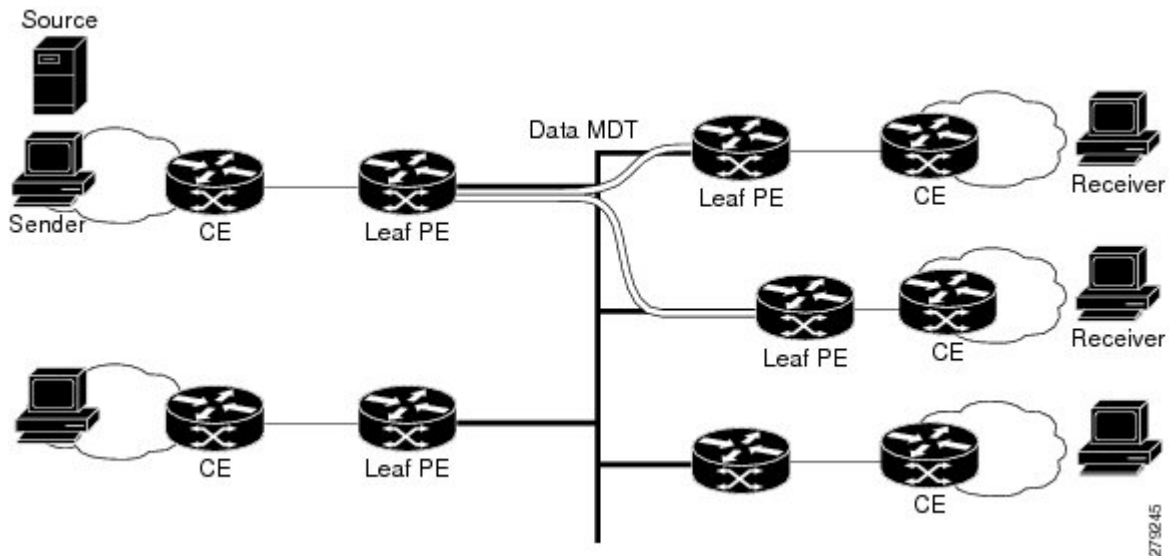

Data MDTs are created only for (S, G) multicast route entries within the VRF multicast routing table. They are not created for (*, G) entries regardless of the value of the individual source data rate.

The only transport mechanism previously available was Protocol Independent Multicast (PIM) with Multipoint Generic Routing Encapsulation (mGRE) over an IP core network. The introduction of Multicast Label Distribution Protocol (MLDP) provides transport by using MLDP with label encapsulation over an MPLS core network.

MLDP creates the MDTs as follows:

- The default MDT uses MP2MP LSPs.
 - Supports low bandwidth and control traffic between VRFs.
- The data MDT uses P2MP LSPs.
 - Supports a single high-bandwidth source stream from a VRF.

All other operations of MVPN remain the same regardless of the tunneling mechanism:

- PIM neighbors in a VRF are seen across a Label Switched Path virtual interface (LSP-VIF).
- The VPN multicast state is signaled by PIM.

The only other difference when using MLDP is that the MDT group address used in the mGRE solution is replaced with a VPN ID.

Benefits of MLDP-Based MVPN

- Enables the use of a single MPLS forwarding plane for both unicast and multicast traffic.
- Enables existing MPLS protection (for example, MPLS Traffic Engineering/Resource Reservation Protocol (TE/RSVP link protection) and MPLS Operations Administration and Maintenance (OAM) mechanisms to be used for multicast traffic.

- Reduces operational complexity due to the elimination of the need for PIM in the MPLS core network.

P2MP and MP2MP Label Switched Paths

mLDP is an application that sets up Multipoint Label Switched Paths (MP LSPs) in MPLS networks without requiring multicast routing protocols in the MPLS core. mLDP constructs the P2MP or MP2MP LSPs without interacting with or relying upon any other multicast tree construction protocol. Using LDP extensions for MP LSPs and Unicast IP routing, mLDP can setup MP LSPs. The two types of MP LSPs that can be setup are Point-to-Multipoint (P2MP) and Multipoint-to-Multipoint (MP2MP) type LSPs.

A P2MP LSP allows traffic from a single root (ingress node) to be delivered to a number of leaves (egress nodes), where each P2MP tree is uniquely identified with a 2-tuple (root node address, P2MP LSP identifier). A P2MP LSP consists of a single root node, zero or more transit nodes, and one or more leaf nodes, where typically root and leaf nodes are PEs and transit nodes are P routers. A P2MP LSP setup is receiver-driven and is signaled using mLDP P2MP FEC, where LSP identifier is represented by the MP Opaque Value element. MP Opaque Value carries information that is known to ingress LSRs and Leaf LSRs, but need not be interpreted by transit LSRs. There can be several MP LSPs rooted at a given ingress node, each with its own identifier.

A MP2MP LSP allows traffic from multiple ingress nodes to be delivered to multiple egress nodes, where a MP2MP tree is uniquely identified with a 2-tuple (root node address, MP2MP LSP identifier). For a MP2MP LSP, all egress nodes, except the sending node, receive a packet sent from an ingress node.

A MP2MP LSP is similar to a P2MP LSP, but each leaf node acts as both an ingress and egress node. To build an MP2MP LSP, you can setup a downstream path and an upstream path so that:

- Downstream path is setup just like a normal P2MP LSP
- Upstream path is setup like a P2P LSP towards the upstream router, but inherits the downstream labels from the downstream P2MP LSP.



Note We recommend that you configure one P2MP MDT tree per prefix. For example, if 500 multicast routes are needed, then you should configure at least 500 P2MP MDT trees.

```
ip vrf vrf-name1
.....!
.....
mdt data mpls mldp 500
```

Packet Flow in mLDP-based Multicast VPN

For each packet coming in, MPLS creates multiple out-labels. Packets from the source network are replicated along the path to the receiver network. The CE1 router sends out the native IP multicast traffic. The PE1 router imposes a label on the incoming multicast packet and replicates the labeled packet towards the MPLS core network. When the packet reaches the core router (P), the packet is replicated with the appropriate labels for the MP2MP default MDT or the P2MP data MDT and transported to all the egress PEs. Once the packet reaches the egress PE, the label is removed and the IP multicast packet is replicated onto the VRF interface.

Realizing a mLDP-based Multicast VPN

There are different ways a Label Switched Path (LSP) built by mLDP can be used depending on the requirement and nature of application such as:

- P2MP LSPs for global table transit Multicast using in-band signaling.
- P2MP/MP2MP LSPs for MVPN based on MI-PMSI or Multidirectional Inclusive Provider Multicast Service Instance (Rosen Draft).
- P2MP/MP2MP LSPs for MVPN based on MS-PMSI or Multidirectional Selective Provider Multicast Service Instance (Partitioned E-LAN).

The router performs the following important functions for the implementation of MLDP:

1. Encapsulating VRF multicast IP packet with GRE/Label and replicating to core interfaces (imposition node).
2. Replicating multicast label packets to different interfaces with different labels (Mid node).
3. Decapsulate and replicate label packets into VRF interfaces (Disposition node).

Supported mLDP Profiles

Profile Name	Supported on mLDPv4	Supported on mLDPv6
Profile 1 Default MDT - MLDP MP2MP - PIM C-mcast Signaling	Yes	Yes
Profile 2 Partitioned MDT - MLDP MP2MP - PIM C-mcast Signaling	No	No
Profile 4 Partitioned MDT - MLDP MP2MP - BGP-AD - PIM C-mcast Signaling	No	No
Profile 5 Partitioned MDT - MLDP P2MP - BGP-AD - PIM C-mcast Signaling	No	No
Profile 6 VRF MLDP - In-band Signaling	Yes	Yes
Profile 7 Global MLDP In-band Signaling	Yes	Yes
Profile 9 Default MDT - MLDP - MP2MP - BGP-AD - PIM C-mcast Signaling	Yes	Yes
Profile 12 Default MDT - MLDP - P2MP - BGP-AD - BGP C-mcast Signaling	Yes	Yes

Profile Name	Supported on mLDIPv4	Supported on mLDIPv6
Profile 13 Default MDT - MLDP - MP2MP - BGP-AD - BGP C-mcast Signaling	Yes	Yes
Profile 14 Partitioned MDT - MLDP P2MP - BGP-AD - BGP C-mast Signaling	Yes	Yes
Profile 15 Partitioned MDT - MLDP MP2MP - BGP-AD - BGP C-mast Signaling	No	No
Profile 17 Default MDT - MLDP - P2MP - BGP-AD - PIM C-mcast Signaling	Yes	Yes

For more information on mLDP profiles, see, <http://www.cisco.com/c/en/us/support/docs/ip/multicast/118985-configure-mcast-00.html#anc0>

Initial Deployment of an MLDP-Based MVPN

Initial deployment of an MLDP-based MVPN involves the configuration of a default MDT and one or more data MDTs.

A static default MDT is established for each multicast domain. The default MDT defines the path used by PE devices to send multicast data and control messages to every other PE device in the multicast domain. A default MDT is created in the core network using a single MP2MP LSP.

An MLDP-based MVPN also supports the dynamic creation of data MDTs for high-bandwidth transmission.

Default MDT Creation

The figure shows the default MDT scenario. The Opaque value used to signal a default MDT consists of two parameters: the VPN ID and the MDT number for the VPN in the format (vpn-id, 0) where vpn-id is a manually configured 7-byte number that uniquely identifies this VPN. The default MDT is set to zero.

In this scenario, each of the three PE devices belong to the VRF called VRF and they have the same VPN ID. Each PE device with the same VPN ID will join the same MP2MP tree. The PE devices have created a primary MP2MP tree rooted at P-Central (Root 1) and a backup MP2MP tree rooted at PE-North (Root 2). There are two sources at PE-West and interested receivers at both PE-North and PE-East. PE-West will choose one of the MP2MP trees to transmit the customer VPN traffic, but all PE devices can receive traffic on either of the MP2MP trees.

Figure 3: Default MDT Scenario

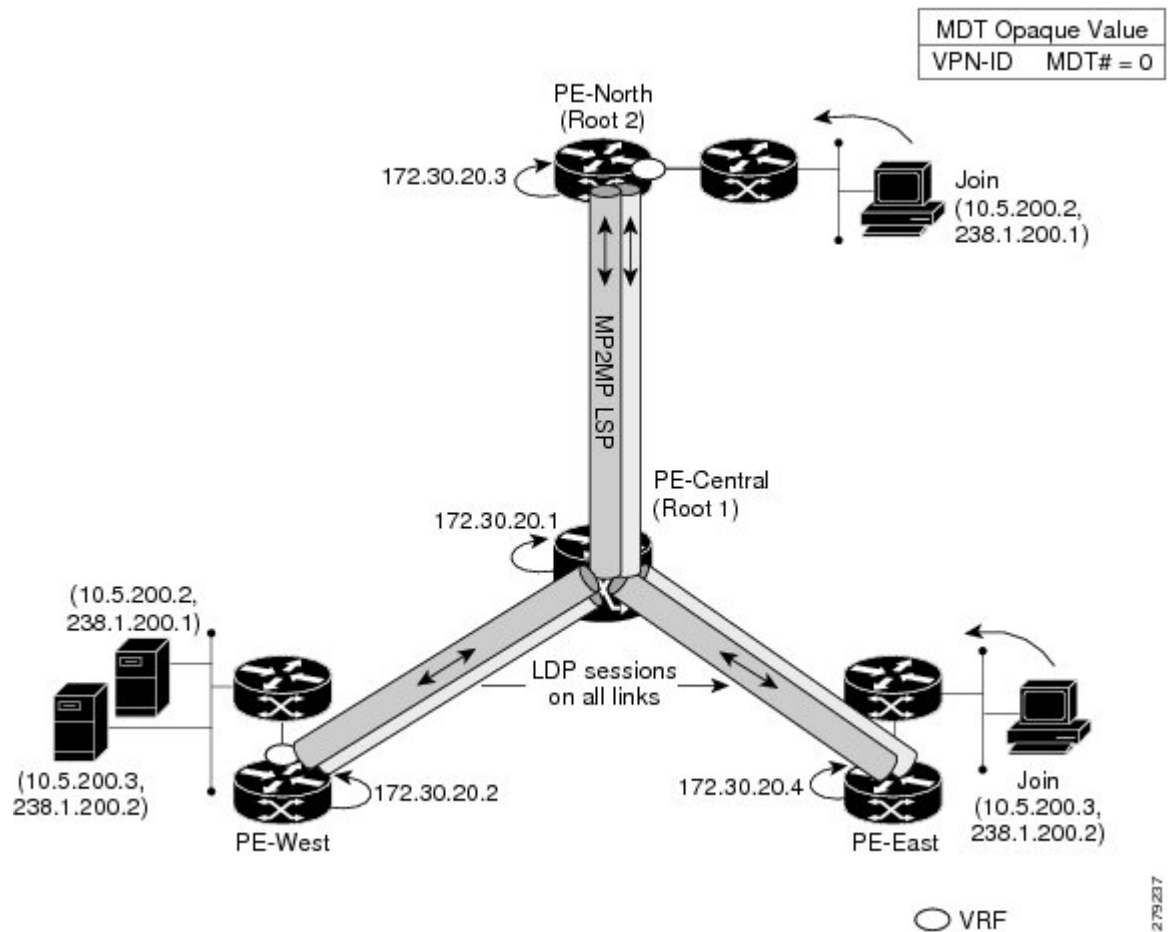

LSP Downstream Default MDT Creation

The figures show the downstream tree creation for each of the roots. Each PE device configured with VPN ID 100:2 creates the same Forwarding Equivalence Class (FEC) Type Length Value (TLV), but with a different root and downstream labels per MP2MP tree. The FEC type will be MP2MP Down, which prompts the receiving Label Switched Route (LSR) to respond with an upstream label mapping message to create the upstream path.

Figure 4: Default MDT Downstream--Root 1

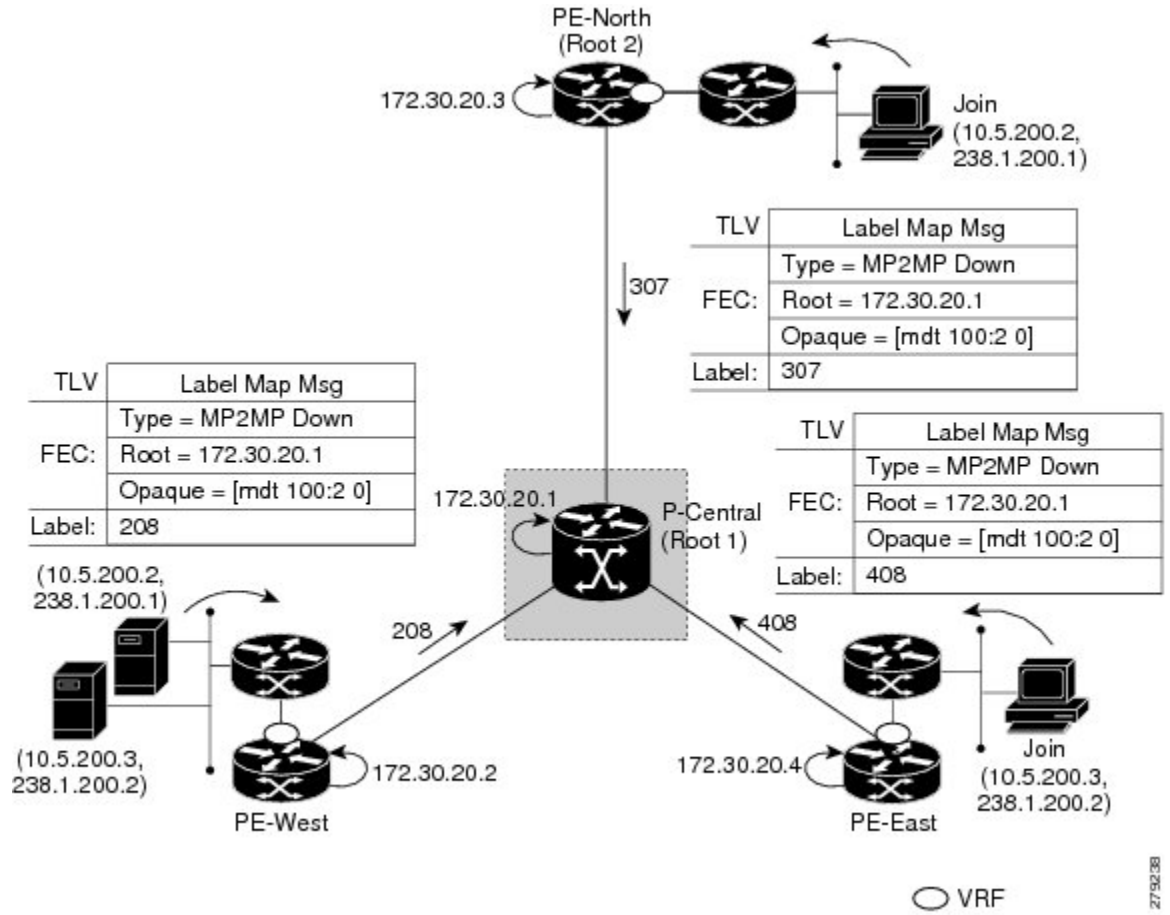

275238

Figure 5: Default MDT Downstream--Root 2

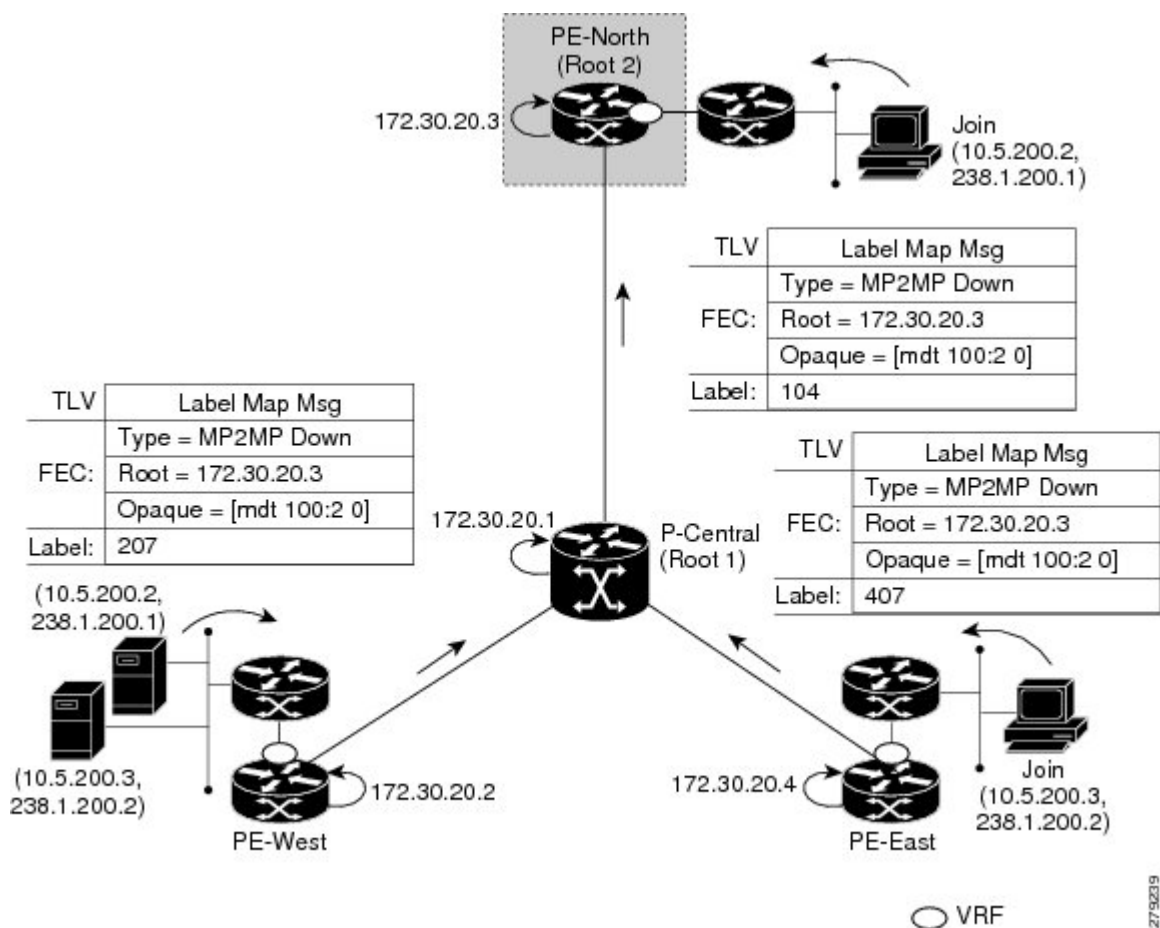

LSP Upstream Default MDT Creation

The figures show the upstream LSP creation for the default MDTs. For each downstream label received, a corresponding upstream label is sent. In the first figure, P-Central sends out three upstream labels (111, 109, and 105) to each downstream directly connected neighbor (downstream is away from the root). The process for PE-North is the same except that it only sends a single upstream label (313) as there is only one directly connected downstream neighbor, as shown in the second figure.

Figure 6: Default MDT Upstream--Root 1

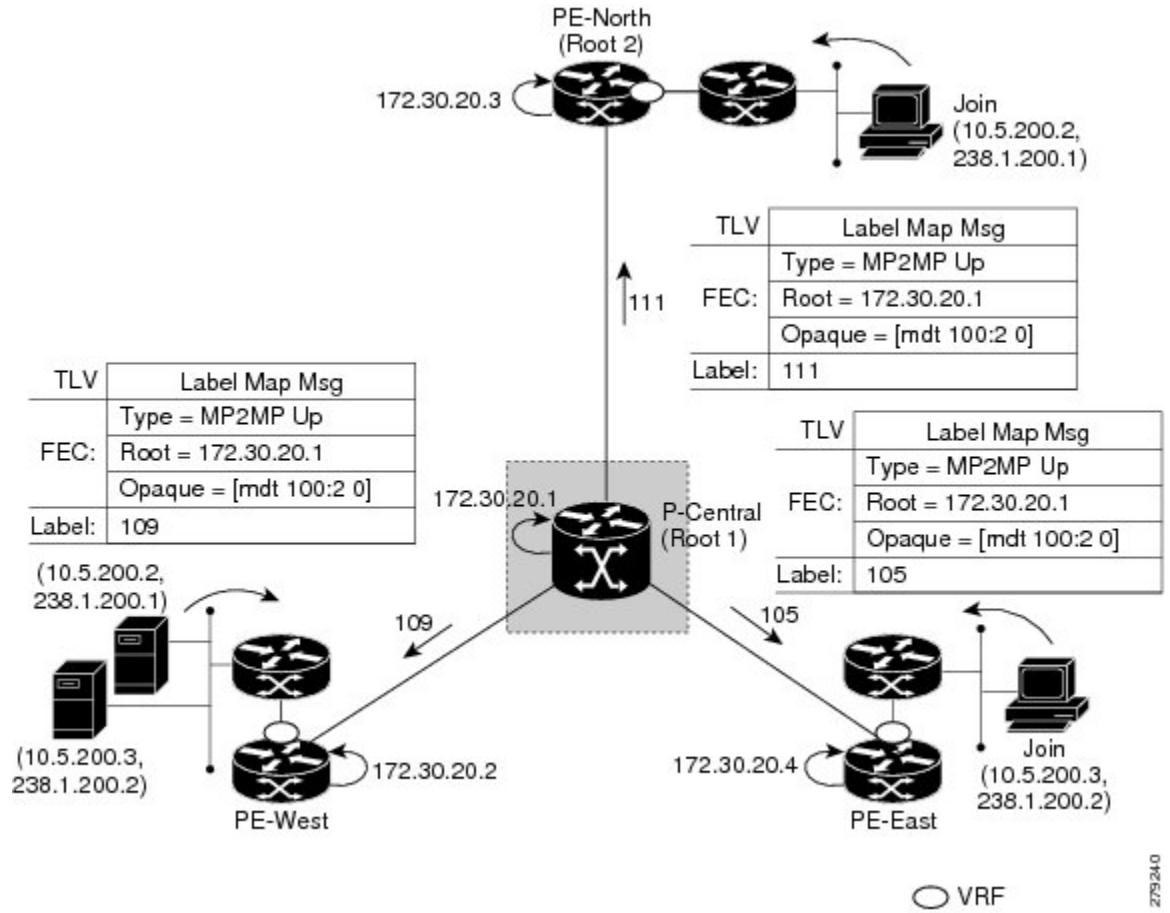

27524.0

Figure 7: Default MDT Upstream--Root 2

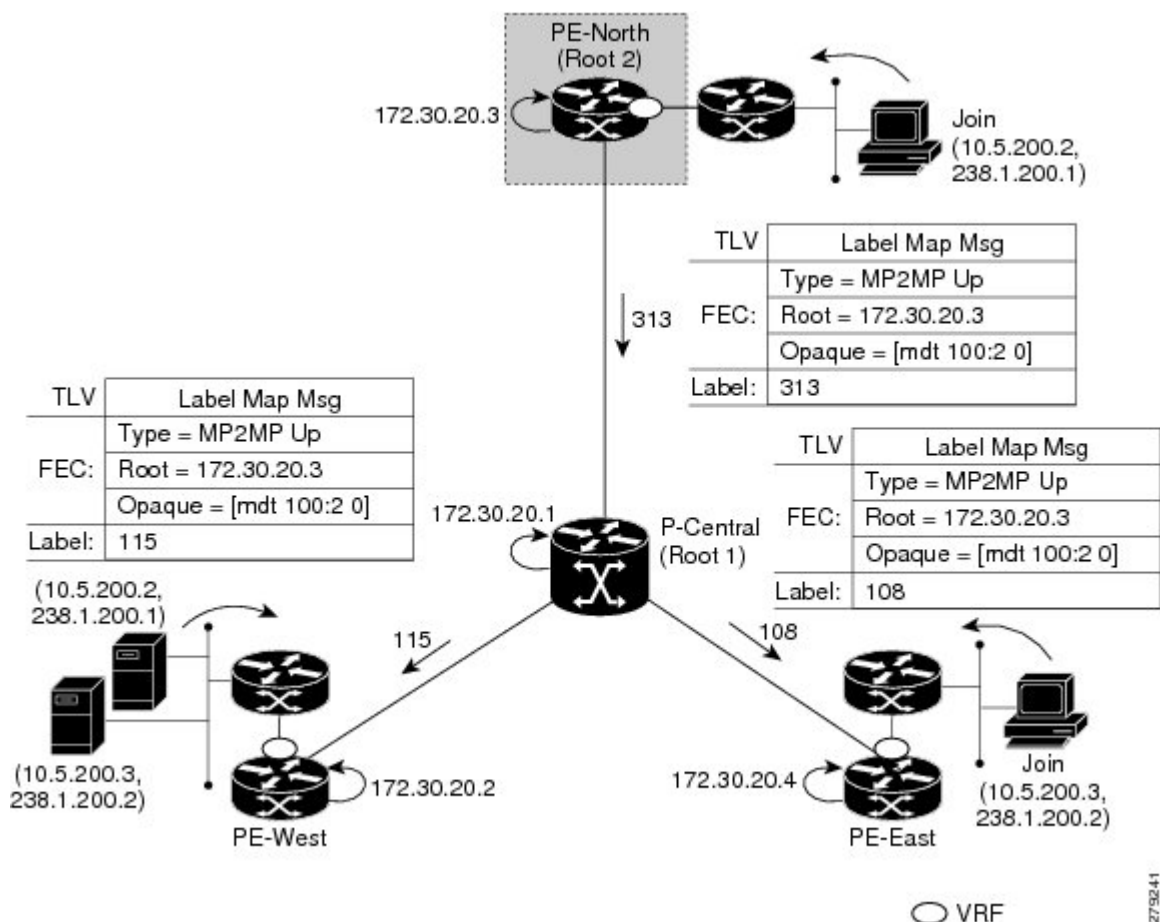

PIM Overlay Signaling of VPN Multicast State

The signaling of the multicast state within a VPN is via PIM. It is called overlay signaling because the PIM session runs over the multipoint LSP and maps the VPN multicast flow to the LSP. In an MVPN, the operation of PIM is independent of the underlying tunnel technology. In the MVPN solution, a PIM adjacency is created between PE devices, and the multicast states within a VRF are populated over the PIM sessions. When using MLDP, the PIM session runs over an LSP-VIF interface. The figure shows PIM signaling running over the default MDT MP2MP LSP. Access to the MP2MP LSP is via the LSP-VIF, which can see all the leaf PE devices at the end of branches, much like a LAN interface. In the figure, PE-East sends a downstream label mapping message to the root, P-Central, which in turn sends an upstream label mapping message to PE-West. These messages result in the creation of the LSP between the two leaf PE devices. A PIM session can then be activated over the top of the LSP allowing the (S, G) states and control messages to be signaled between PE-West and PE-East. In this case, PE-East receives a Join TLV message for (10.5.200.3, 238.1.200.2) within VRF, which it inserts into the mroute table. The Join TLV message is then sent via the PIM session to PE-West (BGP next-hop of 10.5.200.3), which populates its VRF mroute table. This procedure is identical to the procedure using an mGRE tunnel.

Figure 8: PIM Signaling over LSP

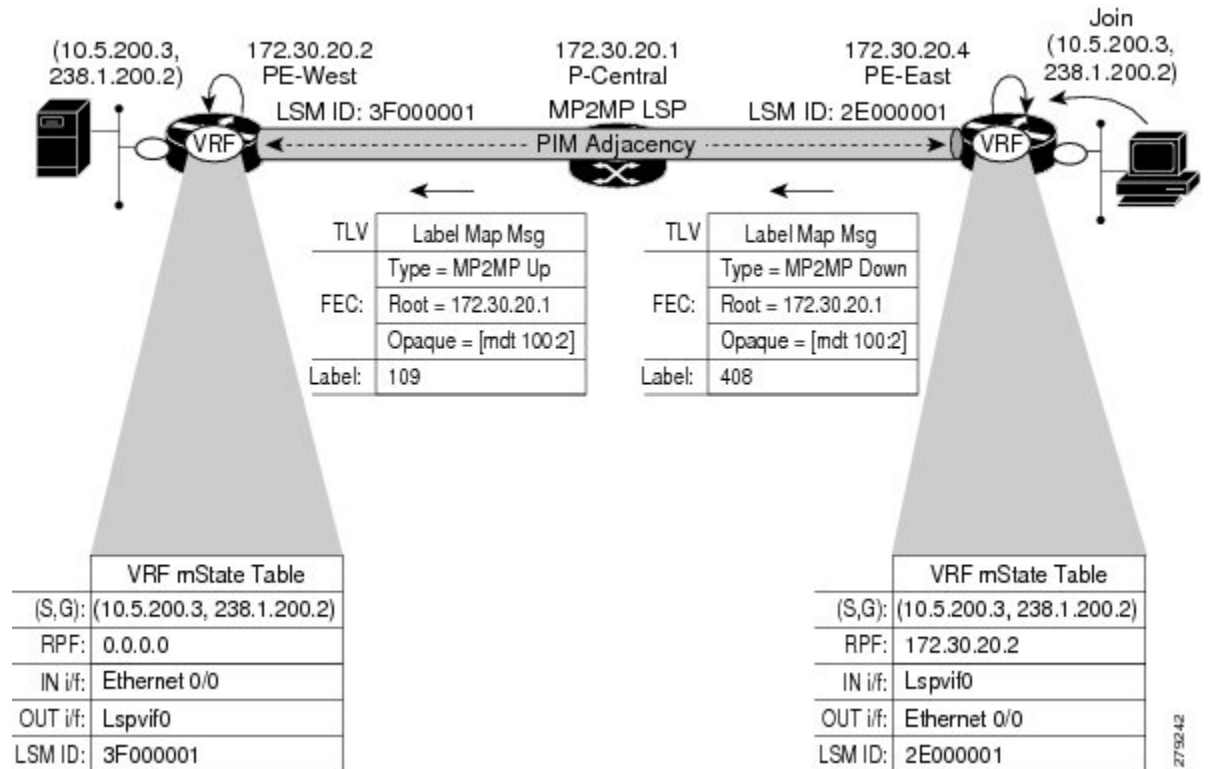

279342

Data MDT Scenario

In an MVPN, traffic that exceeds a certain threshold can move off the default MDT onto a data MDT.

The figure shows the data MDT scenario. The Opaque value used to signal a data MDT consists of two parameters: the VPN ID and the MDT number in the format (vpn-id, MDT# > 0) where vpn-id is a manually configured 7-byte number that uniquely identifies this VPN. The second parameter is the unique data MDT number for this VPN, which is a number greater than zero.

In the scenario, two receivers at PE-North and PE-East are interested in two sources at PE-West. If the source 10.5.200.3 exceeds the threshold on the default MDT, PE-West will issue an MDT Join TLV message over the default MDT MP2MP LSP advising all PE devices that a new data MDT is being created.

Because PE-East has an interested receiver in VRF, it will build a multipoint LSP using P2MP back to PE-West, which will be the root of the tree. PE-North does not have a receiver for 10.5.200.3, therefore it will just cache the Join TLV message.

Figure 9: Data MDT Scenario

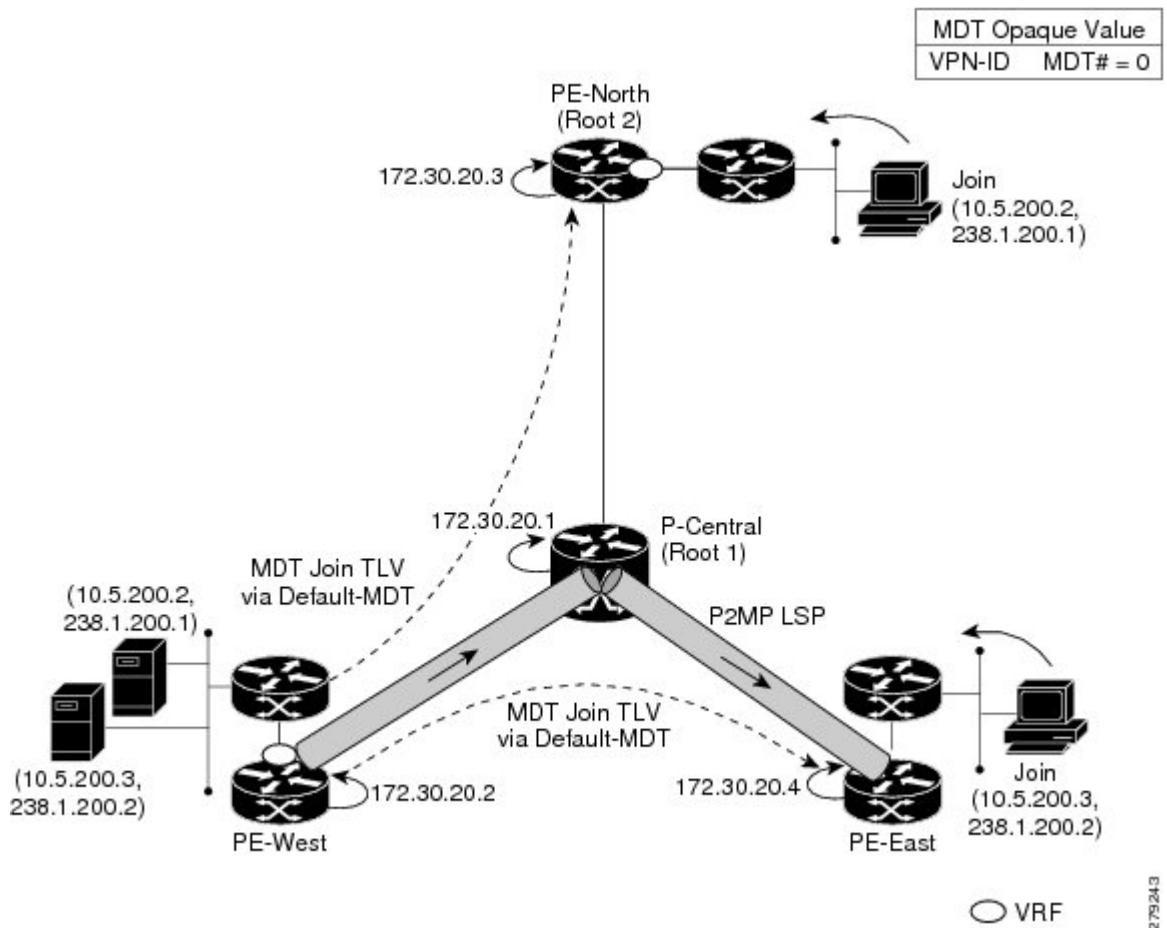

Configuring MLDPv4-Based MVPN

Configuring Initial MLDP Settings

Perform this task to configure the initial MLDP settings.

SUMMARY STEPS

1. enable
2. configure terminal
3. mpls mldp logging notifications
4. mpls mldp forwarding recursive
5. end

DETAILED STEPS

	Command or Action	Purpose
Step 1	enable Example: Device> enable	Enables privileged EXEC mode. <ul style="list-style-type: none"> • Enter your password if prompted.
Step 2	configure terminal Example: Device# configure terminal	Enters global configuration mode.
Step 3	mpls mldp logging notifications Example: Device(config)# mpls mldp logging notifications	Enables MLDP logging notifications.
Step 4	mpls mldp forwarding recursive Example: Device(config)# mpls mldp forwarding recursive	Enables MLDP recursive forwarding over a P2MP LSP.
Step 5	end Example: Device(config)# end	Ends the current configuration session and returns to privileged EXEC mode.

Configuring an MLDP-Based MVPN

Perform this task to configure an MLDP-based MVPN.

SUMMARY STEPS

1. **enable**
2. **configure terminal**
3. **ip multicast-routing**
4. **ip multicast-routing vrf** *vrf-name*
5. **ip vrf** *vrf-name*
6. **rd** *route-distinguisher*
7. **vpn id** *oui* : *vpn-index*
8. **route target export** *route-target-ext-community*
9. **route target import** *route-target-ext-community*
10. **mdt preference** { **mldp** | **pim** }
11. **mdt default mpls mldp** *group-address*
12. **mdt data mpls mldp** *number-of-data-mdt*
13. **mdt data threshold** *kb/s* **list** *access-list*

14. end

DETAILED STEPS

	Command or Action	Purpose
Step 1	enable Example: Device> enable	Enables privileged EXEC mode. <ul style="list-style-type: none">• Enter your password if prompted.
Step 2	configure terminal Example: Device# configure terminal	Enters global configuration mode.
Step 3	ip multicast-routing Example: Device(config)# ip multicast-routing	Enables IP multicast routing.
Step 4	ip multicast-routing vrf vrf-name Example: Device(config)# ip multicast-routing vrf VRF	Enables IP multicast routing for the MVPN VRF specified for the <i>vrf-name</i> argument.
Step 5	ip vrf vrf-name Example: Device(config-vrf)# ip vrf VRF	Defines a VRF instance and enters VRF configuration mode.
Step 6	rd route-distinguisher Example: Device(config-vrf)# rd 50:11	Creates a route distinguisher (RD) (in order to make the VRF functional). Creates the routing and forwarding tables, associates the RD with the VRF instance, and specifies the default RD for a VPN.
Step 7	vpn id oui : vpn-index Example: Device(config-vrf)# vpn id 50:10	Sets or updates the VPN ID on a VRF instance.
Step 8	route target export route-target-ext-community Example: Device(config-vrf)# route target export 100:100	Creates an export route target extended community for the specified VRF.
Step 9	route target import route-target-ext-community Example:	Creates an import route target extended community for the specified VRF.

	Command or Action	Purpose
	Device(config-vrf)# route target import 100:100	
Step 10	mdt preference { mldp / pim } Example: Device(config-vrf)# mdt preference mldp	Specifies a preference for a particular MDT type (MLDP or PIM).
Step 11	mdt default mpls mldp group-address Example: Device(config-vrf)# mdt default mpls mldp 172.30.20.1	Configures a default MDT group for a VPN VRF instance.
Step 12	mdt data mpls mldp number-of-data-mdt Example: Device(config-vrf)# mdt data mpls mldp 255	Specifies a range of addresses to be used in the data MDT pool.
Step 13	mdt data threshold kb/s list access-list Example: Device(config-vrf)# mdt data threshold 40 list 1	Defines the bandwidth threshold value in kilobits per second.
Step 14	end Example: Device(config)# end	Ends the current configuration session and returns to privileged EXEC mode.

Verifying the Configuration of an MLDP-Based MVPN

Perform this task in privileged EXEC mode to verify the configuration of an MLDP-based MVPN.

SUMMARY STEPS

1. show mpls mldp database
2. show ip pim neighbor [vrf vrf-name] neighbor [interface-type interface-number]
3. show ip mroute [vrf vrf-name] [[active [kbps] [interface type number] | bidirectional | count [terse] | dense | interface type number | proxy | pruned | sparse | ssm | static | summary] | [group-address [source-address]] [count [terse] | interface type number | proxy | pruned | summary] | [source-address group-address] [count [terse] | interface type number | proxy | pruned | summary] | [group-address] active [kbps] [interface type number | verbose]]
4. show mpls forwarding-table [network {mask | length} | labels label [- label] | interface interface | next-hop address | lsp-tunnel [tunnel-id]] [vrf vrf-name] [detail]
5. show adjacency [ip-address] [interface-type interface-number | null number | port-channel number | sysclock number | vlan number | fcpa number | serial number] [connectionid number] [link {ipv4 | mpls}] [detail | encapsulation]

DETAILED STEPS

Step 1 show mpls mldp database

Enter the **show mpls mldp database** command to display information in the MLDP database. It shows the FEC, the Opaque value of the FEC decoded, and the replication clients associated with it:

Example:

```
Device# show mpls mldp database
* Indicates MLDP recursive forwarding is enabled
LSM ID : D3000001 (RNR LSM ID: 8A000002)   Type: MP2MP   Uptime : 00:04:54
FEC Root      : 172.30.20.1
Opaque decoded : [mdt 100:2 0]
Opaque length  : 11 bytes
Opaque value   : 07 000B 0000010000000100000000
RNR active LSP : (this entry)
Upstream client(s) :
  172.30.20.1:0   [Active]
    Expires      : Never           Path Set ID   : 99000001
    Out Label (U) : 32             Interface     : Ethernet1/0*
    Local Label (D) : 30           Next Hop      : 10.0.1.7
Replication client(s) :
  MDT (VRF VRF)
    Uptime       : 00:04:54       Path Set ID   : 5000002
    Interface    : Lspvif0
```

Step 2 show ip pim neighbor [vrf vrf-name] neighbor [interface-type interface-number]

Enter the **show ip pim neighbor** command to display PIM adjacencies information:

Example:

```
Device# show ip pim vrf VRF neighbor
192.168.10.18   Serial6/0           04:53:19/00:01:18 v2 1 / G
172.30.20.3     Lspvif0             04:52:32/00:01:28 v2 1 / B S P G
172.30.20.2     Lspvif0             04:52:32/00:01:17 v2 1 / B S P G
```

Step 3 show ip mroute [vrf vrf-name] [[active [kbps] [interface type number] | bidirectional | count [terse] | dense | interface type number | proxy | pruned | sparse | ssm | static | summary] | [group-address [source-address]] [count [terse] | interface type number | proxy | pruned | summary] | [source-address group-address] [count [terse] | interface type number | proxy | pruned | summary] | [group-address] active [kbps] [interface type number | verbose]]

Enter the **show ip mroute** command to display the contents of the multicast routing (mroute) table:

Example:

```
Device# show ip mroute vrf VRF 238.1.200.2 10.5.200.3
(10.5.200.3, 238.1.200.2), 04:54:18/00:02:40, flags: sT
Incoming interface: Lspvif0, RPF nbr 172.30.20.2
Outgoing interface list:
Serial6/0, Forward/Sparse-Dense, 04:54:18/00:02:40
```

Step 4 show mpls forwarding-table [network {mask | length} | labels label [- label] | interface interface | next-hop address | lsp-tunnel [tunnel-id]] [vrf vrf-name] [detail]

Enter the **show mpls forwarding-table** command to display the contents of the MPLS Label Forwarding Information Base (LFIB):

Example:

```

Device# show mpls forwarding-table | inc 1F000001
105 307      mLDP:1F000001    38468      Se5/0      point2point
     208      mLDP:1F000001    38468      Se4/0      point2point
109 307      mLDP:1F000001    34738      Se5/0      point2point
     408      mLDP:1F000001    34738      Se6/0      point2point
111 408      mLDP:1F000001    282        Se6/0      point2point
     208      mLDP:1F000001    282        Se4/0      point2point

```

Step 5 `show adjacency [ip-address] [interface-type interface-number | null number | port-channel number | sysclock number | vlan number | fcpa number | serial number] [connectionid number] [link {ipv4 | mpls}] [detail | encapsulation]`

Enter the `show adjacency` command to display adjacency information for the specified LSP-VIF interface:

Example:

```

Device# show adjacency lspvif0
105 307      mLDP:1F000001    38468      Se5/0      point2point
     208      mLDP:1F000001    38468      Se4/0      point2point
109 307      mLDP:1F000001    34738      Se5/0      point2point
     408      mLDP:1F000001    34738      Se6/0      point2point
111 408      mLDP:1F000001    282        Se6/0      point2point
     208      mLDP:1F000001    282        Se4/0      point2point

```

MLDPv6-Based MVPN

The MLDPv6 based MVPN configuration enables IPv6 multicast packet delivery using MPLS. This configuration uses MPLS labels to construct default P2MP and MP2MP LSPs. The MPLS replication is used as a forwarding mechanism in the core network.

For MLDP MVPN configuration to work, ensure that the global MPLS MLDP configuration is enabled. These LSPs can be used for transporting IPv6 multicast packets, either in the global table or VPN context.

Figure 10: mLDpv6 topology

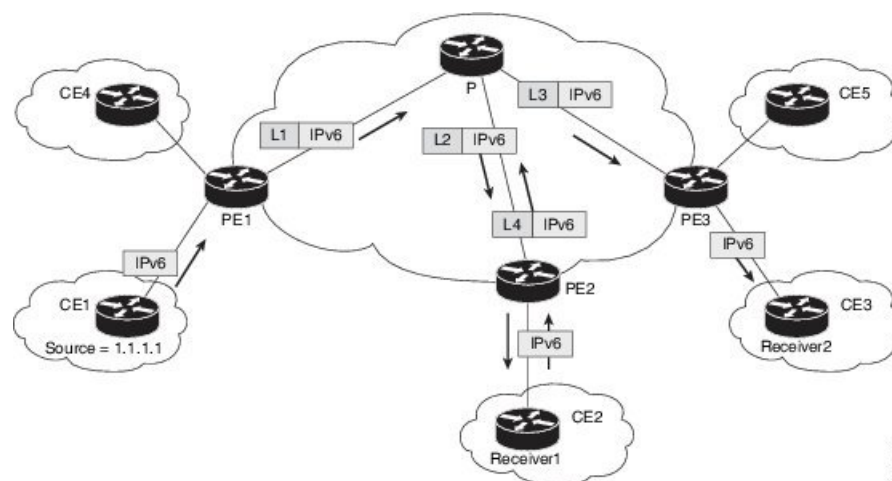

3485-5359

P2MP and MP2MP Label Switched Paths

MLDP is an application that sets up Multipoint Label Switched Paths (MP LSPs) in MPLS networks without requiring multicast routing protocols in the MPLS core. mLDP constructs the P2MP or MP2MP LSPs without interacting with or relying upon any other multicast tree construction protocol. Using LDP extensions for MP LSPs and Unicast IP routing, mLDP can setup MP LSPs. The two types of MP LSPs that can be setup are Point-to-Multipoint (P2MP) and Multipoint-to-Multipoint (MP2MP) type LSPs.

A P2MP LSP allows traffic from a single root (ingress node) to be delivered to a number of leaves (egress nodes), where each P2MP tree is uniquely identified with a 2-tuple (root node address, P2MP LSP identifier). A P2MP LSP consists of a single root node, zero or more transit nodes, and one or more leaf nodes, where typically root and leaf nodes are PEs and transit nodes are P routers. A P2MP LSP setup is receiver-driven and is signaled using mLDP P2MP FEC, where LSP identifier is represented by the MP Opaque Value element. MP Opaque Value carries information that is known to ingress LSRs and Leaf LSRs, but need not be interpreted by transit LSRs. There can be several MP LSPs rooted at a given ingress node, each with its own identifier.

A MP2MP LSP allows traffic from multiple ingress nodes to be delivered to multiple egress nodes, where a MP2MP tree is uniquely identified with a 2-tuple (root node address, MP2MP LSP identifier). For a MP2MP LSP, all egress nodes, except the sending node, receive a packet sent from an ingress node.

A MP2MP LSP is similar to a P2MP LSP, but each leaf node acts as both an ingress and egress node. To build an MP2MP LSP, you can setup a downstream path and an upstream path so that:

- Downstream path is setup just like a normal P2MP LSP
- Upstream path is setup like a P2P LSP towards the upstream router, but inherits the downstream labels from the downstream P2MP LSP.



Note We recommend that you configure one P2MP MDT tree per prefix. For example, if 500 multicast routes are needed, then you should configure at least 500 P2MP MDT trees.

```
ip vrf vrf-name1
.....!
.....
 mdt data mpls mldp 500
```

Packet Flow in mLDP-based Multicast VPN

For each packet coming in, MPLS creates multiple out-labels. Packets from the source network are replicated along the path to the receiver network. The CE1 router sends out the native IP multicast traffic. The PE1 router imposes a label on the incoming multicast packet and replicates the labeled packet towards the MPLS core network. When the packet reaches the core router (P), the packet is replicated with the appropriate labels for the MP2MP default MDT or the P2MP data MDT and transported to all the egress PEs. Once the packet reaches the egress PE, the label is removed and the IP multicast packet is replicated onto the VRF interface.

Realizing a mLDP-based Multicast VPN

There are different ways a Label Switched Path (LSP) built by mLDP can be used depending on the requirement and nature of application such as:

- P2MP LSPs for global table transit Multicast using in-band signaling.

- P2MP/MP2MP LSPs for MVPN based on MI-PMSI or Multidirectional Inclusive Provider Multicast Service Instance (Rosen Draft).
- P2MP/MP2MP LSPs for MVPN based on MS-PMSI or Multidirectional Selective Provider Multicast Service Instance (Partitioned E-LAN).

The router performs the following important functions for the implementation of MLDP:

1. Encapsulating VRF multicast IP packet with GRE/Label and replicating to core interfaces (imposition node).
2. Replicating multicast label packets to different interfaces with different labels (Mid node).
3. Decapsulate and replicate label packets into VRF interfaces (Disposition node).

Supported mLDP Profiles

Profile Name	Supported on mLDPv4	Supported on mLDPv6
Profile 1 Default MDT - MLDP MP2MP - PIM C-mcast Signaling	Yes	Yes
Profile 2 Partitioned MDT - MLDP MP2MP - PIM C-mcast Signaling	No	No
Profile 4 Partitioned MDT - MLDP MP2MP - BGP-AD - PIM C-mcast Signaling	No	No
Profile 5 Partitioned MDT - MLDP P2MP - BGP-AD - PIM C-mcast Signaling	No	No
Profile 6 VRF MLDP - In-band Signaling	Yes	Yes
Profile 7 Global MLDP In-band Signaling	Yes	Yes
Profile 9 Default MDT - MLDP - MP2MP - BGP-AD - PIM C-mcast Signaling	Yes	Yes
Profile 12 Default MDT - MLDP - P2MP - BGP-AD - BGP C-mcast Signaling	Yes	Yes
Profile 13 Default MDT - MLDP - MP2MP - BGP-AD - BGP C-mcast Signaling	Yes	Yes
Profile 14 Partitioned MDT - MLDP P2MP - BGP-AD - BGP C-mast Signaling	Yes	Yes

Profile Name	Supported on mLDPv4	Supported on mLDPv6
Profile 15 Partitioned MDT - MLDP MP2MP - BGP-AD - BGP C-mast Signaling	No	No
Profile 17 Default MDT - MLDP - P2MP - BGP-AD - PIM C-mcast Signaling	Yes	Yes

For more information on mLDP profiles, see, <http://www.cisco.com/c/en/us/support/docs/ip/multicast/118985-configure-mcast-00.html#anc0>

Configuration Rules for Profiles

Rules for Rosen-mGRE profiles (profiles- 0, 3, 11)

- All profiles require VPNv4 or v6 unicast reachability.
- By default, encap 1400-byte size c-multicast IP packet is supported. To support decap or encap larger packet size, **mdt mtu** command.
- Loopback configuration is required. Use the **mdt source loopback0** command. Other loopbacks can be used for different VRFs, but this is not recommended.

Rules for Rosen-mLDP profiles (profiles- 1, 9, 12, 13, 17)

- mLDP must be globally enabled.
- VPN-id is mandatory for Rosen-mLDP MP2MP profiles.
- Root node must be specified manually. Multiple root nodes can be configured for Root Node Redundancy.
- If only profile 1 is configured, MVPN must be enabled under bgp.
- For BGP-AD profiles, the remote PE address is required.

Rules for mLDP profiles (profiles- 2, 4, 5, 14, 15)

Rules for mLDP profiles (profile- 4)

- MVPN must be enabled under bgp, if only profile 2 is configured.
- Support only for static RP for customer RP.

Rules for inband mLDP profiles (profiles- 6, 7)

- MVPN must be enabled under bgp for vrf-inband profiles.
- Data MDT is not supported.
- Backbone facing interface (BFI) must be enabled on tail PE.
- Source route of SSM must be advertise to tail PE by iBGP.

Configuration Examples for MLDP-Based MVPN

Example Initial Deployment of an MLDP-Based MVPN

Initial deployment of an MLDP-based MVPN involves the configuration of a default MDT and one or more data MDTs.

Default MDT Configuration

The following example shows how to configure the default MDT for an MLDP-based MVPN. This configuration is based on the sample topology illustrated in the figure.

Figure 11: Default MDT Example

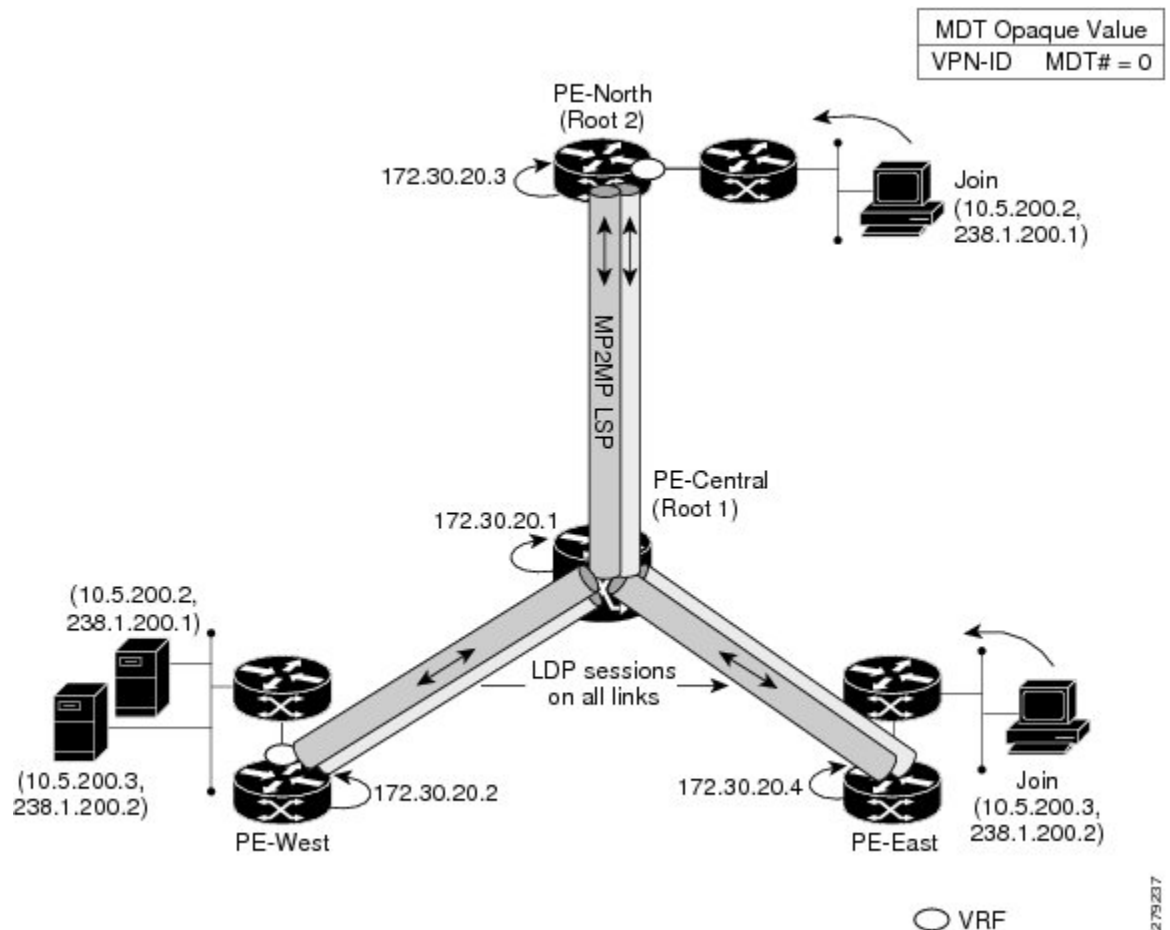

This configuration is consistent for every PE device participating in the same VPN ID. The **vpn id 100:2** command replaces the MDT group address used with the mGRE transport method. To provide redundancy, two default MDT trees are statically configured, rooted at P-Central and PE-North. The selection as to which MP2MP tree the default MDT will use at a particular PE device is determined by Interior Gateway Protocol (IGP) metrics. An MP2MP LSP is implicit for the default MDT.

```

ip pim mpls source Loopback0
ip multicast-routing
ip multicast-routing vrf VRF
!
ip vrf VRF
 rd 100:2
  vpn id 100:2
  route-target export 200:2
  route-target import 200:2
  mdt default mpls mldp 172.30.20.1 (P-Central)
  mdt default mpls mldp 172.30.20.3 (PE-North)

```

PIM Adjacencies

PIM operates over the LSP-VIF as if it were a regular tunnel interface. That means PIM hellos are exchanged over the LSP-VIF to establish PIM adjacencies over the default MDT. The sample output in this section displays the three PIM adjacencies in VRF of PE-East. The first is the adjacency to the receiver network over serial interface 6/0, and the next two are the adjacencies to PE-West and PE-North over the MP2MP LSP via LSP-VIF interface 0.

```

PE-East# show ip pim vrf VRF neighbor
192.168.10.18   Serial6/0           04:53:19/00:01:18 v2 1 / G
172.30.20.3    Lspvif0             04:52:32/00:01:28 v2 1 / B S P G
172.30.20.2    Lspvif0             04:52:32/00:01:17 v2 1 / B S P G

```

The output from the **show ip mroute** command also shows the (S, G) entry for VRF. The stream 238.1.200.2 has the Reverse Path Forwarding (RPF) interface of LSP-VIF interface 0 and the neighbor 172.30.20.2, which is PE-West.

```

PE-East# show ip mroute vrf VRF 238.1.200.2 10.5.200.3
(10.5.200.3, 238.1.200.2), 04:54:18/00:02:40, flags: sT
Incoming interface: Lspvif0, RPF nbr 172.30.20.2
Outgoing interface list:
Serial6/0, Forward/Sparse-Dense, 04:54:18/00:02:40

```

MLDP Database Entry--PE-East

The sample output in this section displays the database entries for the MP2MP trees supporting the default MDT at PE-East. The database is searched by Opaque value MDT 100:2, which results in information for two MP2MP trees (one for each root) being returned. Both trees have different system IDs (2E000001, F2000005) and use the same Opaque value ([mdt 100:2 0]), but with different roots. The last 0 in the Opaque value indicates this tree is a default MDT. Entry 79000004 shows it is the primary MP2MP tree, therefore PE-East will transmit all source multicast traffic on this LSP, and B2000006 will be the backup root. Note that interface LSP-VIF interface 0 represents both MP2MP LSPs. The Local Label (D) is the downstream label allocated by PE-East for this tree. In other words, traffic from the root will be received with either label 408 (Primary Tree) or 407 (Backup Tree). The Out Label (U) is the label that PE-East will use to send traffic into the tree; upstream towards the root, either 105 for the Primary Tree or 108 for the Backup Tree. Both these labels were received from P-Central.

```

PE-East# show mpls mldp database opaque_type mdt 100:2
* Indicates MLDP recursive forwarding is enabled
LSM ID : 79000004 (RNR LSM ID: 8A000002)   Type: MP2MP   Uptime : 00:04:54
  FEC Root      : 172.30.20.1
  Opaque decoded : [mdt 100:2 0]
  Opaque length  : 11 bytes
  Opaque value   : 07 000B 000001000000001000000000
  RNR active LSP : (this entry)

```



```

Upstream client(s) :
  172.30.20.1:0    [Active]
    Expires      : Never          Path Set ID : 99000001
    Out Label (U) : 32            Interface   : Ethernet1/0*
    Local Label (D): 30          Next Hop    : 10.0.1.7
Replication client(s):
  MDT (VRF VRF)
    Uptime       : 00:04:54      Path Set ID : 5000002
    Interface    : Lspvif0
LSM ID : 79000005 (RNR LSM ID: 8A000003)   Type: MP2MP   Uptime : 00:04:54
FEC Root      : 172.30.20.3
Opaque decoded : [mdt 100:2 0]
Opaque length  : 11 bytes
Opaque value   : 07 000B 000001000000001000000001
RNR active LSP : (this entry)
Upstream client(s) :
  172.30.20.1:0    [Active]
    Expires      : Never          Path Set ID : 99000002
    Out Label (U) : 32            Interface   : Ethernet1/0*
    Local Label (D): 30          Next Hop    : 10.0.1.7
Replication client(s):
  MDT (VRF VRF)
    Uptime       : 00:04:54      Path Set ID : 5000003
    Interface    : Lspvif0

```

Label Forwarding Entry--P-Central (Root 1)

The sample output shown in this section displays the VRF (MDT 100:2) MLDP database entry 1F000001 for the primary MP2MP LSP, which is P-Central. Because the local device P-Central is the root, there is no upstream peer ID, therefore no labels are allocated locally. However there are three replication clients, representing each of the three PE devices: PE-North, PE-West, and PE-East. These replication clients are the downstream nodes of the MP2MP LSP. These clients receive multipoint replicated traffic.

In the replication entry looking from the perspective of the root, there are two types of labels:

- Out label (D)--These are labels received from remote peers that are downstream to the root (remember traffic flows downstream away from the root).
- Local label (U)--These are labels provided by P-Central to its neighbors to be used as upstream labels (sending traffic to the root). It is easy to identify these labels as they all start in the 100 range, which we have configured for P-Central to use. P-Central sends these labels out when it receives a FEC with the type as MP2MP Down.

From the labels received and sent in the replication entries, the Label Forwarding Information Base (LFIB) is created. The LFIB has one entry per upstream path and one entry per downstream path. In this case because P-Central is the root, there are only upstream entries in the LFIB that have been merged with the corresponding downstream labels. For example, label 105 is the label P-Central sent to PE-East to send source traffic upstream. Traffic received from PE-East will then be replicated using the downstream labels 307 to PE-West and 208 to PE-North.

```

P-Central# show mpls mldp database opaque_type mdt 100:2
LSM ID : 79000006 (RNR LSM ID: 1F000001)   Type: MP2MP   Uptime : 00:04:54
FEC Root      : 172.30.20.1
Opaque decoded : [mdt 100:2 0]
Opaque length  : 11 bytes
Opaque value   : 07 000B 000001000000001000000000
RNR active LSP : (this entry)
Upstream client(s) : None
Replication client(s):
  172.3.20.2:0

```

```

Uptime      : 01:46:43      Path Set ID : AC000008
Out label (D) : 208        Interface   : Serial4/0
Local label (U) : 109      Next Hop    : 172.30.10.2
172.3.20.3:0
Uptime      : 01:42:43      Path Set ID : E00000C
Out label (D) : 307        Interface   : Serial5/0
Local label (U) : 111      Next Hop    : 172.30.10.6
172.3.20.4:0
Uptime      : 01:40:43      Path Set ID : 3D000010
Out label (D) : 408        Interface   : Serial6/0
Local label (U) : 105      Next Hop    : 172.30.10.10
P-Central# show mpls forwarding-table | inc 1F000001
105  307      mLDP:1F000001    38468      Se5/0      point2point
      208      mLDP:1F000001    38468      Se4/0      point2point
109  307      mLDP:1F000001    34738      Se5/0      point2point
      408      mLDP:1F000001    34738      Se6/0      point2point
111  408      mLDP:1F000001    282        Se6/0      point2point
      208      mLDP:1F000001    282        Se4/0      point2point

```

The sample output shown in this section displays the entry on P-Central for the MP2MP LSP rooted at PE-North (backup root). In this tree P-Central is a branch of the tree, not a root, therefore there are some minor differences to note:

- The upstream peer ID is PE-North, therefore P-Central has allocated label 104 in the downstream direction towards PE-North and subsequently PE-North has responded with an upstream label of 313.
- Two replication entries representing PE-East and PE-West are displayed.
- The merged LFIB shows three entries:
 - One downstream entry label 104 receiving traffic from Root 2 (PE-North), which is then directed further downstream using labels 207 PE-West and 407 PE-East.
 - Two upstream entries 108 and 115 receiving traffic from the leaves and directing it either downstream 207, 407 or upstream using label 313.

```

Central_P# show mpls mldp database opaque_type mdt 100:2
LSM ID      : E6000004
Uptime      : 00:42:03
Tree type   : MP2MP
FEC Root    : 172.30.20.3
Opaque length : 14 bytes
Opaque value : 07000B00 01000000 00020000 00009C
Opaque decoded : [mdt 100:2 0]
Upstream peer ID : 172.30.20.3:0, Label local (D): 104 remote (U): 313 active
Path Set ID   : 48000003
Replication client(s):
172.30.20.2:0 uptime: 00:42:03 Path Set ID: CF000004
                remote label (D): 207 local label (U): 115
                nhop: 172.30.10.2 intrf: Serial4/0
172.30.20.4:0 uptime: 00:41:44 Path Set ID: 5800000E
                remote label (D): 407 local label (U): 108
                nhop: 172.30.10.10 intrf: Serial6/0
Central_P# show mpls forwarding-table | inc E6000004
104  207      mLDP:E6000004    251228     Se4/0      point2point
      407      mLDP:E6000004    251334     Se6/0      point2point
108  207      mLDP:E6000004    0          Se4/0      point2point
      313      mLDP:E6000004    0          Se5/0      point2point
115  313      mLDP:E6000004    0          Se5/0      point2point
      407      mLDP:E6000004    0          Se6/0      point2point

```

Data MDT Configuration

The following example shows how to configure the data MDT for an MLDP-based MVPN. This configuration is based on the sample topology illustrated in the figure.

Figure 12: Data MDT Example

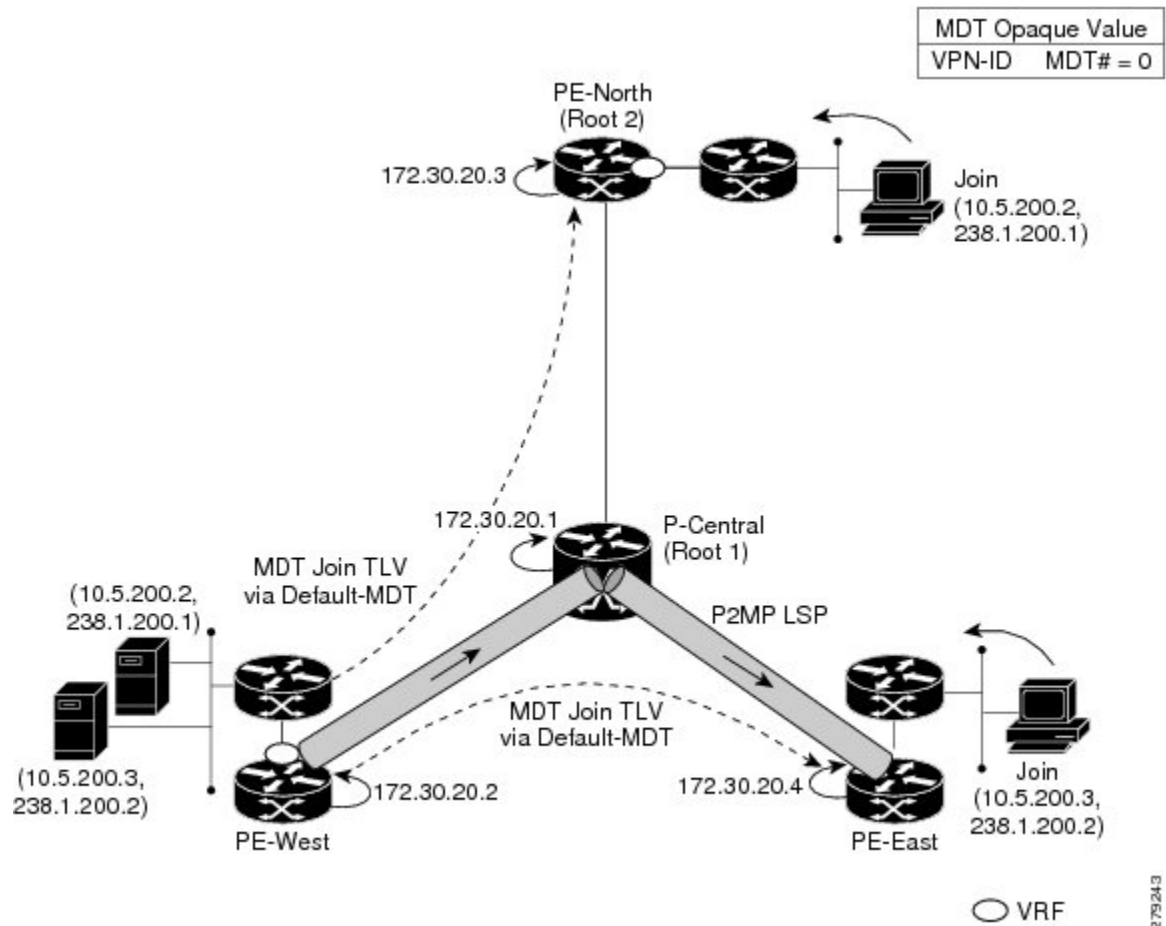

The sample output in this section displays the data MDT configuration for all the PE devices. The **mdt data** commands are the only additional commands necessary. The first **mdt data** command allows a maximum of 60 data MDTs to be created, and the second **mdt data** command sets the threshold. If the number of data MDTs exceeds 60, then the data MDTs will be reused in the same way as they are for the mGRE tunnel method (the one with the lowest reference count).

```
ip pim vrf VRF mpls source Loopback0
!
ip vrf VRF
rd 100:2
vpn id 100:2
route-target export 200:2
route-target import 200:2
mdt default mpls mldp 172.30.20.1 (P-Central)
mdt default mpls mldp 172.30.20.3 (PE-North)
mdt data mpls mldp 60
mdt data threshold 1
```

VRF mroute Table--PE-West

The sample output in this section displays the VRF mroute table on PE-West before the high-bandwidth source exceeds the threshold. At this point there are two streams, representing each of the two VPN sources at PE-West, on a single MP2MP LSP (System ID D8000000). The LSP represents the default MDT accessed via LSP-VIF interface 0.

```
PE-West# show ip mroute vrf VRF verbose
.
.
.
(10.5.200.2, 238.1.200.1), 00:00:25/00:03:29, flags: sT
  Incoming interface: Serial6/0, RPF nbr 192.168.10.6
  Outgoing interface list:
    Lspvif0, LSM MDT: D8000000 (default),Forward/Sparse-Dense,
.
.
.
(10.5.200.3, 238.1.200.2), 00:11:14/00:02:48, flags: sT
  Incoming interface: Serial6/0, RPF nbr 192.168.10.6
  Outgoing interface list:
    Lspvif0, LSM MDT: D8000000 (default),Forward/Sparse-Dense,
.
.
.
```

The sample output in this section displays the output after the source transmission exceeds the threshold. PE-West sends an MDT Join TLV message to signal the creation of a data MDT. In this case, the data MDT number is 1, therefore PE-East will send a label mapping message back to PE-West with a FEC TLV containing root=PE-West, Opaque value=(mdt vpn-id 1). The System ID is now changed to 4E000003 signaling a different LSP; however, the LSP-VIF is still LSP-VIF interface 0. The (S, G) entry also has the “y” flag set indicating this stream has switched to a data MDT.

```
PE-West# show ip mroute vrf VRF 10.5.200.3 238.1.200.2 verbose
.
.
.
(10.5.200.3, 238.1.200.2), 00:00:08/00:03:27, flags: sTy
  Incoming interface: Serial6/0, RPF nbr 192.168.10.6
  MDT TX nr: 1 LSM-ID 4E000003
  Outgoing interface list:
    Lspvif0, LSM MDT: 4E000003 (data) Forward/Sparse-Dense,
```

LSP-VIF Adjacencies--PE-West

For the interface LSP-VIF, each virtual circuit represents a unique multipoint LSP forwarding instance. The correct adjacency is selected when sending the multicast packet. The sample output in this section displays the application of that concept on PE-West. There is a single LSP-VIF interface 0 interface, but it has three adjacencies as follows:

- 4E000003 is the single data MDT created for (10.5.200.3, 238.1.200.2)
- 58000000 is the default MDT (backup root)
- D8000000 is the default MDT (primary root)

```
PE-West# show adjacency lspvif 0

Protocol Interface Address
```

```

IP      Lspvif0          4E000003 (5)
IP      Lspvif0          58000000 (4)
IP      Lspvif0          D8000000 (3)

```

MLDP Database Entries

The sample output in this section displays the MLDP entry for the data MDT (4E000003) on the ingress device PE-West. The following points about this entry should be noted:

- The tree type is P2MP with PE-West (172.30.20.2) as the root.
- The Opaque value is [mdt 100:2 1] denoting the first data MDT.
- There are no labels allocated as it is the root.
- There are two replication client entries on this tree.
- Label 112 will be used to send the traffic downstream towards PE-East (via P-Central).
- The MDT entry is an internal construct.

```
PE-West# show mpls mldp database id 4E000003
```

```

LSM ID : 4E000003 (RNR LSM ID: 8A000002)   Type: P2MP   Uptime : 00:04:54
FEC Root      : 172.30.20.2
Opaque decoded : [mdt 100:2 1]
Opaque length  : 11 bytes
Opaque value   : 07 000B 000001000000001000000000
RNR active LSP : (this entry)
Upstream client(s) : None
Replication client(s):
  MDT (VRF VRF)
    Uptime      : 00:04:54      Path Set ID   : 5000002
    Interface   : Lspvif0
172.30.20.1:0
    Uptime      : 01:41:43      Path Set ID   : D9000007
    Out label (D) : 27          Interface     : Serial4/0
    Local label (U) : 112       Next Hop      : 172.30.10.1

```

The sample output in this section displays the database entry for the data MDT on PE-East, the egress device. Also shown is the MDT Join TLV message that was sent from PE-West over the default MDT. The MDT Join TLV message contains all the necessary information to allow PE-East to create a label mapping message P2MP LSP back to the root of PE-West. Label 414 will be used by P-Central to send traffic to PE-East.

```
*Feb 19 04:43:24.039: PIM(1): MDT join TLV received for (10.5.200.3,238.1.200.2)
```

```
*Feb 19 04:43:24.039: MLDP: LDP root 172.30.20.2 added
```

```
*Feb 19 04:43:24.039: MLDP: [mdt 100:2 1] label mapping msg sent to 172.30.20.1:0
```

```
PE-East# show mpls mldp database opaque_type mdt 100:2 1
```

```

LSM ID : 4E000003 (RNR LSM ID: 8A000002)   Type: P2MP   Uptime : 00:04:54
FEC Root      : 172.30.20.2
Opaque decoded : [mdt 100:2 1]
Opaque length  : 11 bytes
Opaque value   : 07 000B 000001000000001000000000
RNR active LSP : (this entry)
Upstream client(s) : None
Replication client(s):
  MDT (VRF VRF)

```

```

Uptime           : 00:04:54      Path Set ID  : 5000002
Interface        : Lspvif0

```

LFIB Entry for the Data MDT

The sample output in this section displays the LFIB entry for the data MDT as it passes through P-Central and PE-East. The Tunnel ID used for the LSP is the Opaque value [mdt 100:2 1].

```

P-Central# show mpls for label 112
Local      Outgoing  Prefix          Bytes Label  Outgoing  Next Hop
Label      Label      or Tunnel Id    Switched      interface
111        414        [mdt 100:2 1]  2993584      Se6/0     point2point
PE-East# show mpls for label 400

Local      Outgoing  Prefix          Bytes Label  Outgoing  Next Hop
Label      Label      or Tunnel Id    Switched      interface
414 [T] No Label  [mdt 100:2 1][V] 3297312      aggregate/green

```