



## L2VPN Interworking

---

Layer 2 Virtual Private Network (L2VPN) Interworking allows you to connect disparate attachment circuits. This feature module explains how to configure the following L2VPN Interworking features:

- Ethernet/VLAN to ATM AAL5 Interworking
  - Ethernet/VLAN to Frame Relay Interworking
  - Ethernet/VLAN to PPP Interworking
  - Ethernet to VLAN Interworking
  - Frame Relay to ATM AAL5 Interworking
  - Frame Relay to PPP Interworking
  - Ethernet/VLAN to ATM virtual channel identifier (VPI) and virtual channel identifier (VCI) Interworking
  - L2VPN Interworking: VLAN Enable/Disable Option for AToM
- 
- [Finding Feature Information, page 1](#)
  - [Prerequisites for L2VPN Interworking, page 2](#)
  - [Restrictions for L2VPN Interworking, page 2](#)
  - [Information About L2VPN Interworking, page 12](#)
  - [How to Configure L2VPN Interworking, page 16](#)
  - [Configuration Examples for L2VPN Interworking, page 26](#)
  - [Additional References, page 34](#)
  - [Feature Information for L2VPN Interworking, page 36](#)

## Finding Feature Information

Your software release may not support all the features documented in this module. For the latest caveats and feature information, see [Bug Search Tool](#) and the release notes for your platform and software release. To find information about the features documented in this module, and to see a list of the releases in which each feature is supported, see the feature information table at the end of this module.

Use Cisco Feature Navigator to find information about platform support and Cisco software image support. To access Cisco Feature Navigator, go to [www.cisco.com/go/cfn](http://www.cisco.com/go/cfn). An account on Cisco.com is not required.

## Prerequisites for L2VPN Interworking

Before you configure L2VPN Interworking on a router:

- You must enable Cisco Express Forwarding.
- On the Cisco 12000 series Internet router, before you configure Layer 2 Tunnel Protocol version 3 (L2TPv3) for L2VPN Interworking on an IP Services Engine (ISE/Engine 3) or Engine 5 interface, you must also enable the L2VPN feature bundle on the line card.

To enable the feature bundle, enter the **hw-module slot np mode feature** command in global configuration mode as follows:

```
Router# configure terminal
Router(config)# hw-module slot slot-number np mode feature
```

## Restrictions for L2VPN Interworking

### General Restrictions

This section lists general restrictions that apply to L2VPN Interworking. Other restrictions that are platform-specific or device-specific are listed in the following sections.

- The interworking type on one provider edge (PE) router must match the interworking type on the peer PE router.
- The following quality of service (QoS) features are supported with L2VPN Interworking:
  - Static IP type of service (ToS) or Multiprotocol Label Switching (MPLS) experimental bit (EXP) setting in tunnel header
  - IP ToS reflection in tunnel header (Layer 2 Tunnel Protocol Version 3 (L2TPv3) only)
  - Frame Relay policing
  - Frame Relay data-link connection identifier (DLCI)-based congestion management (Cisco 7500/Versatile Interface Processor (VIP))
  - One-to-one mapping of VLAN priority bits to MPLS EXP bits
- Only ATM AAL5 VC mode is supported; ATM VP and port mode are not supported.
- In Cisco IOS Release 12.2(52)SE and Cisco IOS Release 12.2(33)SRE, the **encapsulation** command supports only the **mpls** keyword. The **l2tpv3** keyword is not supported. The **interworking** command supports only the **ethernet** and **vlan** keywords. The **ip** keyword is not supported.

## Cisco 7600 Series Routers Restrictions

The following line cards are supported on the Cisco 7600 series router. The first table below shows the line cards that are supported on the WAN (ATM, Frame Relay, or PPP) side of the interworking link. The second table below shows the line cards that are supported on the Ethernet side of the interworking link. For more details on the Cisco 7600 routers supported shared port adapters and line cards, see the following document:

- [Release Notes for Cisco IOS Release 12.2SR for the Cisco 7600 Series Routers](#)

**Table 1: Cisco 7600 Series Routers: Supported Line Cards for the WAN Side**

Interworking Type	Core-Facing Line Cards	Customer-Edge Line Cards
Ethernet (bridged) (ATM and Frame Relay)	Any	EflexWAN SIP-200 SIP-400
IP (routed) (ATM, Frame Relay, and PPP)	Any	EflexWAN SIP-200

**Table 2: Cisco 7600 Series Routers: Supported Line Cards for the Ethernet Side**

Interworking Type	Ethernet over MPLS Mode	Core-Facing Line Cards	Customer-Edge Line Cards
Ethernet (bridged)	Policy feature card (PFC) based	Any, except optical service module (OSM) and ES40	Catalyst LAN SIP-600
Ethernet (bridged)	Switched virtual interface (SVI) based	EflexWAN ES20 ES+40 SIP-200 SIP-400 SIP-600	Catalyst LAN EflexWAN (with MPB) ES20 ES+40 SIP-200 (with MPB) SIP-400 (with MPB) SIP-600
Ethernet (bridged)	Scalable (with E-MPB)	Any, except OSM	ES20 SIP-600 and SIP-400 with Gigabit Ethernet (GE) SPA
IP (routed)	PFC-based	Catalyst LAN SIP-600 <b>Note:</b> PFC-based mode is not supported with routed interworking in Cisco IOS Release 12.2(33)SRD. Use SVI, Scalable, or Ethernet virtual connection (EVC) based Ethernet over MPLS (EoMPLS) instead.	Catalyst LAN SIP-600 <b>Note:</b> PFC-based mode is not supported with routed interworking in Cisco IOS Release 12.2(33)SRD. Use SVI, Scalable, or EVC-based EoMPLS instead.

Interworking Type	Ethernet over MPLS Mode	Core-Facing Line Cards	Customer-Edge Line Cards
IP (routed)	SVI-based	Any, except Catalyst LAN and OSM.	Catalyst LAN EflexWAN (with MPB) ES20 SIP-200 (with MPB) SIP-400 (with MPB) SIP-600

The following restrictions apply to the Cisco 7600 series routers and L2VPN Interworking:

- OAM Emulation is not required with L2VPN Interworking on the SIP-200, SIP-400, and Flexwan2 line cards.
- Cisco 7600 series routers support the L2VPN Interworking: VLAN Enable/Disable Option for ATOM feature starting in Cisco IOS Release 12.2(33)SRE. This feature has the following restrictions:
  - PFC-based EoMPLS is not supported.
  - Scalable and SVI-based EoMPLS are supported with the SIP-400 line card.
- The Cisco 7600 series routers do not support L2VPN Interworking over L2TPv3.
- Cisco 7600 series routers support only the following interworking types:
  - Ethernet/VLAN to Frame Relay (IP and Ethernet modes)
  - Ethernet/VLAN to ATM AAL5SNAP (IP and Ethernet modes)
  - Ethernet/VLAN to PPP (IP only)
  - Ethernet to VLAN Interworking
- Cisco 7600 series routers do not support the following interworking types:
  - Ethernet/VLAN to ATM AAL5MUX
  - Frame Relay to PPP Interworking
  - Frame Relay to ATM AAL5 Interworking
- Both ends of the interworking link must be configured with the same encapsulation and interworking type:
  - If you use Ethernet encapsulation, you must use the Ethernet (bridged) interworking type. If you are not using Ethernet encapsulation, you can use a bridging mechanism, such as routed bridge encapsulation (RBE).
  - If you use an IP encapsulation (such as ATM or Frame Relay), you must use the IP (routed) interworking type. The PE routers negotiate the process for learning and resolving addresses.
  - You must use the same MTU size on the attachment circuits at each end of the pseudowire.
- PFC-based EoMPLS is not supported on ES40 line cards. SVI and EVC/scalable EoMPLS are the alternative options.

- PFC-based EoMPLS is not supported for Routed/IP interworking in Cisco IOS Release 12.2(33)SRD and later releases. The alternative Routed/IP interworking options are SVI and EVC or scalable EoMPLS. However, PFC-based EoMPLS is supported for Ethernet/Bridged interworking and for like-to-like over AToM.

## Cisco 12000 Series Router Restrictions

For more information about hardware requirements on the Cisco 12000 series routers, see the [Cross-Platform Release Notes for Cisco IOS Release 12.0S](#).

For QoS support on the Cisco 12000 series routers, see Any Transport over MPLS (AToM): Layer 2 QoS (Quality of Service) for the Cisco 12000 Series Router

### Frame Relay to PPP and High-Level Data Link Control Interworking

The Cisco 12000 series Internet router does not support L2VPN Interworking with PPP and high-level data link control (HDLC) transport types in Cisco IOS releases earlier than Cisco IOS Release 12.0(32)S.

In Cisco IOS Release 12.0(32)S and later releases, the Cisco 12000 series Internet router supports L2VPN interworking for Frame Relay over MPLS and PPP and HDLC over MPLS only on the following shared port adapters (SPAs):

- ISE/Engine 3 SPAs:
  - SPA-2XCT3/DS0 (2-port channelized T3 to DS0)
  - SPA-4XCT3/DS0 (4-port channelized T3 to DS0)
- Engine 5 SPAs:
  - SPA-1XCHSTM1/OC-3 (1-port channelized STM-1c/OC-3c to DS0)
  - SPA-8XCHT1/E1 (8-port channelized T1/E1)
  - SPA-2XOC-48-POS/RPR (2-port OC-48/STM16 POS/RPR)
  - SPA-OC-192POS-LR (1-port OC-192/STM64 POS/RPR)
  - SPA-OC-192POS-XFP (1-port OC-192/STM64 POS/RPR)

### L2VPN Interworking over L2TPv3

On the Cisco 12000 series Internet router, Ethernet (bridged) interworking is not supported for L2TPv3. Only IP (routed) interworking is supported.

IP (routed) interworking is not supported in an L2TPv3 pseudowire that is configured for data sequencing (using the **sequencing** command).

In Cisco IOS Release 12.0(32)SY and later releases, the Cisco 12000 series Internet router supports L2VPN Interworking over L2TPv3 tunnels in IP mode on ISE and Engine 5 line cards as follows:

- On an ISE interface configured for L2TPv3 tunneling, the following Layer 2 encapsulations are supported:
  - ATM adaptation layer type-5 (AAL5)
  - Ethernet

- 802.1q (VLAN)
  - Frame Relay DLCI
- On an Engine 5 interface configured for L2TPv3 tunneling, the following Layer 2 encapsulations are supported:
- Ethernet
  - 802.1q (VLAN)
  - Frame Relay DLCI

For more information, refer to Layer 2 Tunnel Protocol Version 3.

The only frame format supported for L2TPv3 interworking on Engine 5 Ethernet SPAs is Ethernet Version 2 (also known as Ethernet II) with the Ether type 0x0800 value set as Internet Protocol Payload and (optionally) 802.1q VLAN. Ethernet packets with other Ethernet frame formats are dropped.

### Remote Ethernet Port Shutdown Support

The Cisco Remote Ethernet Port Shutdown feature (which minimizes potential data loss after a remote link failure) is supported only on the following Engine 5 Ethernet SPAs:

- SPA-8XFE (8-port Fast Ethernet)
- SPA-2X1GE (2-port Gigabit Ethernet)
- SPA-5X1GE (5-port Gigabit Ethernet)
- SPA-10X1GE (10-port Gigabit Ethernet)
- SPA-1X10GE (1-port 10-Gigabit Ethernet)

For more information about this feature, refer to Any Transport over MPLS (AToM): Remote Ethernet Port Shutdown.

### L2VPN Any-to-Any Interworking on Engine 5 Line Cards

The table below shows the different combinations of transport types supported for L2VPN interworking on Engine 3 and Engine 5 SPA interfaces connected through an attachment circuit over MPLS or L2TPv3.

**Table 3: Engine 3 and Engine 5 Line Cards/SPAs Supported for L2VPN Interworking**

Attachment Circuit 1 (AC1)	Attachment Circuit 2 (AC2)	Interworking Mode	AC1 Engine Type and Line Card/SPA	AC2 Engine Type and Line Card/SPA
Frame Relay	Frame Relay	IP	Engine 5 POS and channelized	Engine 3 ATM line cards
Frame Relay	ATM	Ethernet	Engine 5 POS and channelized	Engine 3 ATM line cards
Frame Relay	ATM	IP	Engine 5 POS and channelized	Engine 3 ATM line cards

Attachment Circuit 1 (AC1)	Attachment Circuit 2 (AC2)	Interworking Mode	AC1 Engine Type and Line Card/SPA	AC2 Engine Type and Line Card/SPA
Frame Relay	Ethernet	Ethernet	Engine 5 POS and channelized	Engine 5 Gigabit Ethernet
Frame Relay	Ethernet	IP	Engine 5 POS and channelized	Engine 5 Gigabit Ethernet
Frame Relay	VLAN	Ethernet	Engine 5 POS and channelized	Engine 5 Gigabit Ethernet
Frame Relay	VLAN	IP	Engine 5 POS and channelized	Engine 5 Gigabit Ethernet
Ethernet	Ethernet	Ethernet	Engine 5 Gigabit Ethernet	Engine 5 Gigabit Ethernet
Ethernet	Ethernet	IP	Engine 5 Gigabit Ethernet	Engine 5 Gigabit Ethernet
Ethernet	VLAN	Ethernet	Engine 5 Gigabit Ethernet	Engine 5 Gigabit Ethernet
Ethernet	VLAN	IP	Engine 5 Gigabit Ethernet	Engine 5 Gigabit Ethernet
ATM	Ethernet	Ethernet	Engine 3 ATM line cards	Engine 5 Gigabit Ethernet
ATM	Ethernet	IP	Engine 3 ATM line cards	Engine 5 Gigabit Ethernet

On the Cisco 12000 series Engine 3 line card, Network Layer Protocol ID (NLPID) encapsulation is not supported in routed mode; and neither NLPID nor AAL5MUX is supported in bridged mode.

- On the Cisco 12000 series Internet router, Ethernet (bridged) interworking is not supported for L2TPv3.

In an L2VPN Interworking configuration, after you configure L2TPv3 tunnel encapsulation for a pseudowire using the **encapsulation l2tpv3** command, you cannot enter the **interworking ethernet** command.

- On Ethernet SPAs on the Cisco 12000 series Internet router, the only frame format supported for L2TPv3 interworking is Ethernet Version 2 (also known as Ethernet II) with the Ether type 0x0800 value set as Internet Protocol Payload and [optionally] 802.1q VLAN.

Ethernet packets with other Ethernet frame formats are dropped.

## ATM AAL5 Interworking Restrictions

The following restrictions apply to ATM AAL5 Interworking:

- Switched virtual circuits (SVCs) are not supported.
- Inverse Address Resolution Protocol (ARP) is not supported with IP interworking.
- Customer edge (CE) routers must use point-to-point subinterfaces or static maps.
- Both AAL5MUX and AAL5SNAP encapsulation are supported. In the case of AAL5MUX, no translation is needed.
- In the Ethernet end-to-end over ATM scenario, the following translations are supported:
  - Ethernet without LAN frame check sequence (FCS) (AAAA030080C200070000)
  - Spanning tree (AAAA030080c2000E)

Everything else is dropped.

- In the IP over ATM scenario, the IPv4 (AAAA030000000800) translation is supported. Everything else is dropped.
- Operation, Administration, and Management (OAM) emulation for L2VPN Interworking is the same as like-to-like. The end-to-end F5 loopback cells are looped back on the PE router. When the pseudowire is down, an F5 end-to-end segment Alarm Indication Signal (AIS)/Remote Defect Identification (RDI) is sent from the PE router to the CE router.
- Interim Local Management Interface (ILMI) can manage virtual circuits (VCs) and permanent virtual circuits (PVCs).
- To enable ILMI management, configure ILMI PVC 0/16 on the PE router's ATM interface. If a PVC is provisioned or deleted, an `ilmiVCCChange` trap is sent to the CE router.
- Only the user side of the User-Network Interface (UNI) is supported; the network side of the UNI is not supported.

## Ethernet VLAN Interworking Restrictions

The following restrictions apply to Ethernet/VLAN interworking:

- When you configure VLAN to Ethernet interworking, VLAN to Frame Relay (routed), or ATM using Ethernet (bridged) interworking, the PE router on the Ethernet side that receives a VLAN tagged frame from the CE router removes the VLAN tag. In the reverse direction, the PE router adds the VLAN tag to the frame before sending the frame to the CE router.

(If you enable the L2VPN Interworking: VLAN Enable/Disable Option for AToM feature with the **interworking vlan** command, VLAN ID is included as part of the Ethernet frame. See the [VLAN Interworking](#), on page 14 for more information. )

- In bridged interworking from VLAN to Frame Relay, the Frame Relay PE router does not strip off VLAN tags from the Ethernet traffic it receives.
- The Cisco 10720 Internet router supports Ethernet to VLAN Interworking Ethernet only over L2TPv3.



- Ethernet interworking for a raw Ethernet port or a VLAN trunk is not supported. Traffic streams are not kept separate when traffic is sent between transport types.
- In routed mode, only one CE router can be attached to an Ethernet PE router.
- There must be a one-to-one relationship between an attachment circuit and the pseudowire. Point-to-multipoint or multipoint-to-point configurations are not supported.
- Configure routing protocols for point-to-point operation on the CE routers when configuring an Ethernet to non-Ethernet setup.
- In the IP interworking mode, the IPv4 (0800) translation is supported. The PE router captures ARP (0806) packets and responds with its own MAC address (proxy ARP). Everything else is dropped.
- The Ethernet or VLAN must contain only two IP devices: PE router and CE router. The PE router performs proxy ARP and responds to all ARP requests it receives. Therefore, only one CE and one PE router should be on the Ethernet or VLAN segment.
- If the CE routers are doing static routing, you can perform the following tasks:
  - The PE router needs to learn the MAC address of the CE router to correctly forward traffic to it. The Ethernet PE router sends an Internet Control Message Protocol (ICMP) Router discovery protocol (RDP) solicitation message with the source IP address as zero. The Ethernet CE router responds to this solicitation message. To configure the Cisco CE router's Ethernet or VLAN interface to respond to the ICMP RDP solicitation message, issue the **ip irdp** command in interface configuration mode. If you do not configure the CE router, traffic is dropped until the CE router sends traffic toward the PE router.
  - To disable the CE routers from running the router discovery protocol, issue the **ip irdp maxadvertinterval 0** command in interface mode.
- This restriction applies if you configure interworking between Ethernet and VLAN with Catalyst switches as the CE routers. The spanning tree protocol is supported for Ethernet interworking. Ethernet interworking between an Ethernet port and a VLAN supports spanning tree protocol only on VLAN 1. Configure VLAN 1 as a nonnative VLAN.
- When you change the interworking configuration on an Ethernet PE router, clear the ARP entry on the adjacent CE router so that it can learn the new MAC address. Otherwise, you might experience traffic drops.

## Restrictions

The following restrictions apply to the L2VPN Interworking: VLAN Enable/Disable Option for AToM feature, which allows the VLAN ID to be included as part of the Ethernet frame:

- The L2VPN Interworking: VLAN Enable/Disable Option for AToM feature is supported on the following releases:
  - Cisco IOS release 12.2(52)SE for the Cisco Catalyst 3750 Metro switches
  - Cisco IOS Release 12.2(33)SRE for the Cisco 7600 series routers
- L2VPN Interworking: VLAN Enable/Disable Option for AToM is not supported with L2TPv3. You can configure the feature only with AToM.

- If the interface on the PE router is a VLAN interface, it is not necessary to specify the **interworking vlan** command on that PE router.
- The L2VPN Interworking: VLAN Enable/Disable Option for AToM feature works only with the following attachment circuit combinations:
  - Ethernet to Ethernet
  - Ethernet to VLAN
  - VLAN to VLAN
- If you specify an interworking type on a PE router, that interworking type must be enforced. The interworking type must match on both PE routers. Otherwise, the VC may be in an incompatible state and remain in the down state. If the attachment circuit (AC) is VLAN, the PE router can negotiate (autosense) the VC type using Label Distribution Protocol (LDP).

For example, both PE1 and PE2 use Ethernet interfaces, and VLAN interworking is specified on PE1 only. PE2 is not configured with an interworking type and cannot autosense the interworking type. The result is an incompatible state where the VC remains in the down state.

On the other hand, if PE1 uses an Ethernet interface and VLAN interworking is enabled (which will enforce VLAN as the VC type), and PE2 uses a VLAN interface and interworking is not enabled (which causes PE2 to use Ethernet as its default VC type), PE2 can autosense and negotiate the interworking type and select VLAN as the VC type.

The table below summarizes shows the AC types, interworking options, and VC types after negotiation.

**Table 4: Negotiating Ethernet and VLAN Interworking Types**

PE1 AC Type	Interworking Option	PE2 AC Type	Interworking Option	VC Type after Negotiation
Ethernet	none	Ethernet	none	Ethernet
Vlan	none	Ethernet	none	Ethernet
Ethernet	none	Vlan	none	Ethernet
Vlan	none	Vlan	none	Ethernet
Ethernet	Vlan	Ethernet	none	Incompatible
Vlan	Vlan	Ethernet	none	Incompatible
Ethernet	Vlan	Vlan	none	Vlan
Vlan	Vlan	Vlan	none	Vlan
Ethernet	none	Ethernet	Vlan	Incompatible
Vlan	none	Ethernet	Vlan	Vlan
Ethernet	none	Vlan	Vlan	Incompatible

PE1 AC Type	Interworking Option	PE2 AC Type	Interworking Option	VC Type after Negotiation
Vlan	none	Vlan	Vlan	Vlan
Ethernet	Vlan	Ethernet	Vlan	Vlan
Vlan	Vlan	Ethernet	Vlan	Vlan
Ethernet	Vlan	Vlan	Vlan	Vlan
Vlan	Vlan	Vlan	Vlan	Vlan

## Frame Relay Interworking Restrictions

The following restrictions apply to Frame Relay interworking:

- The attachment circuit maximum transmission unit (MTU) sizes must match when you connect them over MPLS. By default, the MTU size associated with a Frame Relay DLCI is the interface MTU. This may cause problems, for example, when connecting some DLCIs on a PoS interface (with a default MTU of 4470 bytes) to Ethernet or VLAN (with a default MTU of 1500 bytes) and other DLCIs on the same PoS interface to ATM (with a default MTU of 4470 bytes). To avoid reducing all the interface MTUs to the lowest common denominator (1500 bytes in this case), you can specify the MTU for individual DLCIs using the **mtu** command.
- Only DLCI mode is supported. Port mode is not supported.
- Configure Frame Relay switching to use DCE or Network-to-Network Interface (NNI). DTE mode does not report status in the Local Management Interface (LMI) process. If a Frame Relay over MPLS circuit goes down and the PE router is in DTE mode, the CE router is never informed of the disabled circuit. You must configure the **frame-relay switching** command in global configuration mode in order to configure DCE or NNI.
- Frame Relay policing is non-distributed on the Cisco 7500 series routers. If you enable Frame Relay policing, traffic is sent to the route switch processor for processing.
- Inverse ARP is not supported with IP interworking. CE routers must use point-to-point subinterfaces or static maps.
- The PE router automatically supports translation of both the Cisco encapsulations and the Internet Engineering Task Force (IETF) encapsulations that come from the CE, but translates only to IETF when sending to the CE router. This is not a problem for the Cisco CE router, because it can handle IETF encapsulation on receipt even if it is configured to send Cisco encapsulation.
- With Ethernet interworking, the following translations are supported:
  - Ethernet without LAN FCS (0300800080C20007 or 6558)
  - Spanning tree (0300800080C2000E or 4242)

All other translations are dropped.

- With IP interworking, the IPv4 (03CC or 0800) translation is supported. All other translations are dropped.
- PVC status signaling works the same way as in like-to-like case. The PE router reports the PVC status to the CE router, based on the availability of the pseudowire. PVC status detected by the PE router will also be reflected into the pseudowire. LMI to OAM interworking is supported when you connect Frame Relay to ATM.

## PPP Interworking Restrictions

The following restrictions apply to PPP interworking:

- There must be a one-to-one relationship between a PPP session and the pseudowire. Multiplexing of multiple PPP sessions over the pseudowire is not supported.
- There must be a one-to-one relationship between a PPP session and a Frame Relay DLCI. Each Frame Relay PVC must have only one PPP session.
- Only IP (IPv4 (0021) interworking is supported. Link Control Protocol (LCP) packets and Internet Protocol Control Protocol (IPCP) packets are terminated at the PE router. Everything else is dropped.
- Proxy IPCP is automatically enabled on the PE router when IP interworking is configured on the pseudowire.
- By default, the PE router assumes that the CE router knows the remote CE router's IP address.
- Password Authentication Protocol (PAP) and Challenge-Handshake Authentication Protocol (CHAP) authentication are supported.

## Information About L2VPN Interworking

### Overview of L2VPN Interworking

Layer 2 transport over MPLS and IP already exists for like-to-like attachment circuits, such as Ethernet-to-Ethernet or PPP-to-PPP. L2VPN Interworking builds on this functionality by allowing disparate attachment circuits to be connected. An interworking function facilitates the translation between the different

Layer 2 encapsulations. The figure below is an example of Layer 2 interworking, where ATM and Frame Relay packets travel over the MPLS cloud.

**Figure 1: ATM to Frame Relay Interworking Example**

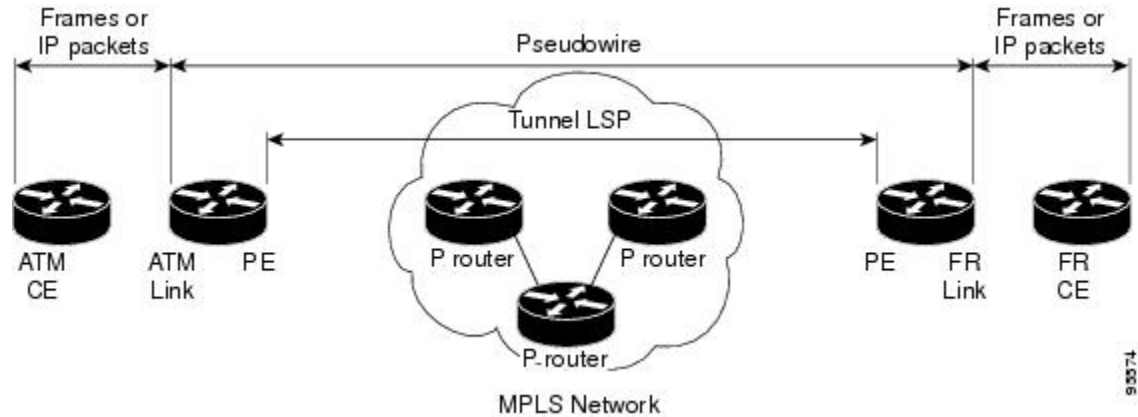

The L2VPN Interworking feature supports Ethernet, 802.1Q (VLAN), Frame Relay, ATM AAL5, and PPP attachment circuits over MPLS and L2TPv3. The features and restrictions for like-to-like functionality also apply to L2VPN Interworking.

## L2VPN Interworking Modes

L2VPN Interworking works in either Ethernet (“bridged”) mode, IP (“routed”), or Ethernet VLAN mode. You specify the mode by issuing the **interworking {ethernet | ip | vlan}** command in pseudowire-class configuration mode.

### Ethernet (Bridged) Interworking

The **ethernet** keyword causes Ethernet frames to be extracted from the attachment circuit and sent over the pseudowire. Ethernet end-to-end transmission is assumed. Attachment circuit frames that are not Ethernet are dropped. In the case of VLAN, the VLAN tag is removed, leaving an untagged Ethernet frame.

Ethernet Interworking is also called bridged interworking. Ethernet frames are bridged across the pseudowire. The CE routers could be natively bridging Ethernet or could be routing using a bridged encapsulation model, such as Bridge Virtual Interface (BVI) or RBE. The PE routers operate in Ethernet like-to-like mode.

This mode is used to offer the following services:

- LAN services--An example is an enterprise that has several sites, where some sites have Ethernet connectivity to the service provider (SP) network and others have ATM connectivity. The enterprise wants LAN connectivity to all its sites. In this case, traffic from the Ethernet or VLAN of one site can be sent through the IP/MPLS network and encapsulated as bridged traffic over an ATM VC of another site.
- Connectivity services--An example is an enterprise that has different sites that are running an Internal Gateway Protocol (IGP) routing protocol, which has incompatible procedures on broadcast and nonbroadcast links. The enterprise has several sites that are running an IGP, such as Open Shortest Path First (OSPF) or Intermediate System to Intermediate System (IS-IS), between the sites. In this scenario,

some of the procedures (such as route advertisement or designated router) depend on the underlying Layer 2 protocol and are different for a point-to-point ATM connection versus a broadcast Ethernet connection. Therefore, the bridged encapsulation over ATM can be used to achieve homogenous Ethernet connectivity between the CE routers running the IGP.

## IP (Routed) Interworking

The **ip** keyword causes IP packets to be extracted from the attachment circuit and sent over the pseudowire. Attachment circuit frames that do not contain IPv4 packets are dropped.

IP Interworking is also called routed interworking. The CE routers encapsulate IP on the link between the CE and PE routers. A new VC type is used to signal the IP pseudowire in MPLS and L2TPv3. Translation between the Layer 2 and IP encapsulations across the pseudowire is required. Special consideration needs to be given to address resolution and routing protocol operation, because these are handled differently on different Layer 2 encapsulations.

This mode is used to provide IP connectivity between sites, regardless of the Layer 2 connectivity to these sites. It is different from a Layer 3 VPN because it is point-to-point in nature and the service provider does not maintain any customer routing information.

Address resolution is encapsulation dependent:

- Ethernet uses ARP
- Frame Relay and ATM use Inverse ARP
- PPP uses IPCP

Therefore, address resolution must be terminated on the PE router. End-to-end address resolution is not supported. Routing protocols operate differently over broadcast and point-to-point media. For Ethernet, the CE routers must either use static routing or configure the routing protocols to treat the Ethernet side as a point-to-point network.

## VLAN Interworking

The **vlan** keyword allows the VLAN ID to be included as part of the Ethernet frame. In Cisco IOS Release 12.2(52)SE, you can configure Catalyst 3750 Metro switches to use Ethernet VLAN for Ethernet (bridged) interworking. You can specify the Ethernet VLAN (type 4) by issuing the **interworking vlan** command in pseudowire-class configuration mode. This allows the VLAN ID to be included as part of the Ethernet frame. In releases previous to Cisco IOS Release 12.2(52)SE, the only way to achieve VLAN encapsulation is to ensure the CE router is connected to the PE router through an Ethernet VLAN interface/subinterface.

## L2VPN Interworking Support Matrix

The supported L2VPN Interworking features are listed in the table below.

**Table 5: L2VPN Interworking Supported Features**

Feature	MPLS or L2TPv3 Support	IP or Ethernet Support
Ethernet/VLAN to ATM AAL5	MPLS L2TPv3 (12000 series only)	IP Ethernet

Feature	MPLS or L2TPv3 Support	IP or Ethernet Support
Ethernet/VLAN to Frame Relay	MPLS L2TPv3	IP Ethernet
Ethernet/VLAN to PPP	MPLS	IP
Ethernet to VLAN	MPLS L2TPv3	IP Ethernet <sup>1</sup>
L2VPN Interworking: VLAN Enable/Disable Option for AToM	MPLS	Ethernet VLAN
Frame Relay to ATM AAL5	MPLS L2TPv3 (12000 series only)	IP
Frame Relay to Ethernet or VLAN	MPLS L2TPv3	IP Ethernet
Frame Relay to PPP	MPLS L2TPv3	IP
<p><b>Note</b> : On the Cisco 12000 series Internet router:</p> <ul style="list-style-type: none"> <li>• Ethernet (bridged) interworking is not supported for L2TPv3.</li> <li>• IP (routed) interworking is not supported in an L2TPv3 pseudowire configured for data sequencing (using the <b>sequencing</b> command).</li> </ul>		

<sup>1</sup> With the L2VPN Interworking: VLAN Enable/Disable Option for AToM feature, VLAN interworking can also be supported. For more information, see the “VLAN Interworking” section on page 14 .

## Static IP Addresses for L2VPN Interworking for PPP

If the PE router needs to perform address resolution with the local CE router for PPP, you can configure the remote CE router’s IP address on the PE router. Issue the **ppp ipcp address proxy** command with the remote CE router’s IP address on the PE router’s xconnect PPP interface. The following example shows a sample configuration:

```
pseudowire-class ip-interworking
  encapsulation mpls
  interworking ip
interface Serial2/0
  encapsulation ppp
  xconnect 10.0.0.2 200 pw-class ip-interworking
  ppp ipcp address proxy 10.65.32.14
```

You can also configure the remote CE router’s IP address on the local CE router with the **peer default ip address** command if the local CE router performs address resolution.

# How to Configure L2VPN Interworking

## Configuring L2VPN Interworking

L2VPN Interworking allows you to connect disparate attachment circuits. Configuring the L2VPN Interworking feature requires that you add the **interworking** command to the list of commands that make up the pseudowire. The steps for configuring the pseudowire for L2VPN Interworking are included in this section. You use the **interworking** command as part of the overall AToM or L2TPv3 configuration. For specific instructions on configuring AToM or L2TPv3, see the following documents:

- Layer 2 Tunnel Protocol Version 3
- Any Transport over MPLS

### SUMMARY STEPS

1. **enable**
2. **configure terminal**
3. **hw-module slot *slot-number* np mode feature**
4. **pseudowire-class *name***
5. **encapsulation {mpls | l2tpv3}**
6. **interworking {ethernet | ip} | vlan}**

### DETAILED STEPS

	Command or Action	Purpose
<b>Step 1</b>	<b>enable</b>  <b>Example:</b> Router> enable	Enables privileged EXEC mode.  <ul style="list-style-type: none"> <li>• Enter your password if prompted.</li> </ul>
<b>Step 2</b>	<b>configure terminal</b>  <b>Example:</b> Router# configure terminal	Enters global configuration mode.
<b>Step 3</b>	<b>hw-module slot <i>slot-number</i> np mode feature</b>  <b>Example:</b> Router(config)# hw-module slot 3 np mode feature	(Optional) Enables L2VPN Interworking functionality on the Cisco 12000 series router.  <b>Note</b> Enter this command only on a Cisco 12000 series Internet router if you use L2TPv3 for L2VPN Interworking on an ISE (Engine 3) or Engine 5 interface. In this case, you must first enable the L2VPN feature bundle on the line card by entering the <b>hw-module slot <i>slot-number</i> np mode feature</b> command.



	Command or Action	Purpose
<b>Step 4</b>	<p><b>pseudowire-class</b> <i>name</i></p> <p><b>Example:</b></p> <pre>Router(config)# pseudowire-class class1</pre>	Establishes a pseudowire class with a name that you specify and enters pseudowire class configuration mode.
<b>Step 5</b>	<p><b>encapsulation</b> {mpls   l2tpv3}</p> <p><b>Example:</b></p> <pre>Router(config-pw)# encapsulation mpls</pre>	Specifies the tunneling encapsulation, which is either <b>mpls</b> or <b>l2tpv3</b> .
<b>Step 6</b>	<p><b>interworking</b> {ethernet   ip}   vlan}</p> <p><b>Example:</b></p> <pre>Router(config-pw)# interworking ip</pre>	<p>Specifies the type of pseudowire and the type of traffic that can flow across it.</p> <p><b>Note</b> On the Cisco 12000 series Internet router, Ethernet (bridged) interworking is not supported for L2TPv3. After you configure the L2TPv3 tunnel encapsulation for the pseudowire using the <b>encapsulation l2tpv3</b> command, you cannot enter the <b>interworking ethernet</b> command.</p>

## Verifying the L2VPN Interworking Configuration

To verify the L2VPN Interworking configuration, you can use the following commands.

### SUMMARY STEPS

1. **enable**
2. **show l2tun session all (L2TPv3 only)**
3. **show arp**
4. **ping**
5. **show l2tun session interworking (L2TPv3 only)**
6. **show mpls l2transport vc detail (AToM only)**

### DETAILED STEPS

- 
- Step 1**     **enable**  
Enables privileged EXEC mode. Enter your password if prompted.
- Step 2**     **show l2tun session all (L2TPv3 only)**  
For L2TPv3, you can verify the L2VPN Interworking configuration using the **show l2tun session all** command on the PE routers.

In the following example, the interworking type is shown in bold.

<b>PE1</b>	<b>PE2</b>
------------	------------

PE1	PE2
<pre> Router# show l2tun session all  Session Information Total tunnels 1 sessions 1  Session id 15736 is up, tunnel id 35411  Call serial number is 4035100045  Remote tunnel name is PE2  Internet address is 10.9.9.9  Session is L2TP signalled  Session state is established, time since change 1d22h  16 Packets sent, 16 received  1518 Bytes sent, 1230 received  Receive packets dropped:  out-of-order:          0  total:                 0  Send packets dropped:  exceeded session MTU:  0  total:                 0  Session vcid is 123  Session Layer 2 circuit, type is Ethernet, name is FastEthernet1/1/0  Circuit state is UP  Remote session id is 26570, remote tunnel id 46882  DF bit off, ToS reflect disabled, ToS value 0, TTL value 255  No session cookie information available </pre>	<pre> Router# show l2tun session all  Session Information Total tunnels 1 sessions 1  Session id 26570 is up, tunnel id 46882  Call serial number is 4035100045  Remote tunnel name is PE1  Internet address is 10.8.8.8  Session is L2TP signalled  Session state is established, time since change 1d22h  16 Packets sent, 16 received  1230 Bytes sent, 1230 received  Receive packets dropped:  out-of-order:          0  total:                 0  Send packets dropped:  exceeded session MTU:  0  total:                 0  Session vcid is 123  Session Layer 2 circuit, type is Ethernet Vlan, name is FastEthernet2/0.1:10  Circuit state is UP, <b>interworking type is Ethernet</b>  Remote session id is 15736, remote tunnel id 35411  DF bit off, ToS reflect disabled, ToS value 0, TTL value 255  No session cookie information available </pre>

PE1	PE2
<pre> FS cached header information:  encap size = 24 bytes  00000000 00000000 00000000 00000000  00000000 00000000  Sequencing is off </pre>	<pre> FS cached header information:  encap size = 24 bytes  00000000 00000000 00000000 00000000  00000000 00000000  Sequencing is off </pre>

**Step 3** **show arp**

You can issue the **show arp** command between the CE routers to ensure that data is being sent:

**Example:**

```

Router# show arp
Protocol  Address      Age (min)  Hardware Addr  Type   Interface
Internet  10.1.1.5     134       0005.0032.0854 ARPA   FastEthernet0/0
Internet  10.1.1.7     -         0005.0032.0000 ARPA   FastEthernet0/0

```

**Step 4** **ping**

You can issue the **ping** command between the CE routers to ensure that data is being sent:

**Example:**

```

Router# ping 10.1.1.5
Type escape sequence to abort.
Sending 5, 100-byte ICMP Echos to 10.1.1.5, timeout is 2 seconds:
!!!!
Success rate is 100 percent (5/5), round-trip min/avg/max = 1/2/4 ms

```

**Step 5** **show l2tun session interworking (L2TPv3 only)**

For L2TPv3, you can verify that the interworking type is correctly set using the **show l2tun session interworking** command. Enter the command on the PE routers that are performing the interworking translation.

- In Example 1, the PE router performs the raw Ethernet translation. The command output displays the interworking type with a dash (-).
- In Example 2, the PE router performs the Ethernet VLAN translation. The command output displays the interworking type as ETH.

Command Output for Raw Ethernet Translation

**Example:**

```

Router# show l2tun session interworking
Session Information Total tunnels 1 sessions 1
LocID      TunID      Peer-address  Type IWrk Username, Intf/Vcid, Circuit
15736     35411     10.9.9.9      ETH  -   123, Fa1/1/0

```

Command Output for Ethernet VLAN Translation

**Example:**

```
Router# show l2tun session interworking
Session Information Total tunnels 1 sessions 1
LocID      TunID      Peer-address  Type IWrk Username, Intf/Vcid, Circuit
26570     46882     10.8.8.8      VLAN ETH 123,      Fa2/0.1:10
```

**Step 6** show mpls l2transport vc detail (AToM only)

You can verify the AToM configuration by using the **show mpls l2transport vc detail** command. In the following example, the interworking type is shown in bold.

PE1	PE2
<pre> Router# <b>show mpls l2transport vc detail</b>  Local interface: Fa1/1/0 up, line protocol up, Ethernet up    Destination address: 10.9.9.9, VC ID: 123, VC status: up      Preferred path: not configured      Default path: active      Tunnel label: 17, next hop 10.1.1.3    Output interface: Fa4/0/0, imposed label stack {17 20}    Create time: 01:43:50, last status change time: 01:43:33    Signaling protocol: LDP, peer 10.9.9.9:0 up    MPLS VC labels: local 16, remote 20    Group ID: local 0, remote 0    MTU: local 1500, remote 1500    Remote interface description:  Sequencing: receive disabled, send disabled  VC statistics:    packet totals: receive 15, send 4184    byte totals:   receive 1830, send 309248    packet drops: receive 0, send 0 </pre>	<pre> Router# <b>show mpls l2transport vc detail</b>  Local interface: Fa2/0.3 up, line protocol up, Eth VLAN 10 up    MPLS VC type is Ethernet, <b>interworking type is Ethernet</b>    Destination address: 10.8.8.8, VC ID: 123, VC status: up      Preferred path: not configured      Default path: active      Tunnel label: 16, next hop 10.1.1.3    Output interface: Fa6/0, imposed label stack {16 16}    Create time: 00:00:26, last status change time: 00:00:06    Signaling protocol: LDP, peer 10.8.8.8:0 up    MPLS VC labels: local 20, remote 16    Group ID: local 0, remote 0    MTU: local 1500, remote 1500    Remote interface description:  Sequencing: receive disabled, send disabled  VC statistics:    packet totals: receive 5, send 0    byte totals:   receive 340, send 0    packet drops: receive 0, send 0 </pre>

## Configuring L2VPN Interworking: VLAN Enable-Disable Option for AToM

You can specify the Ethernet VLAN (type 4) by issuing the **interworking vlan** command in pseudowire-class configuration mode. This allows the VLAN ID to be included as part of the Ethernet frame. In releases previous to Cisco IOS Release 12.2(52)SE and Cisco IOS Release 12.2(33)SRE, the only way to achieve VLAN encapsulation is to ensure the CE router is connected to the PE router through an Ethernet link.

### Before You Begin

For complete instructions on configuring AToM, see "Any Transport over MPLS".

### SUMMARY STEPS

1. **enable**
2. **configure terminal**
3. **pseudowire-class** *name*
4. **encapsulation** {mpls | l2tpv3}
5. **interworking** {ethernet | ip} **vlan**
6. **end**
7. **show mpls l2transport vc** [**vcid** *vc-id* | **vcid** *vc-id-min* *vc-id-max*] [**interface** *type number* [*local-circuit-id*]] [**destination** *ip-address* | *name*] [**detail**]

### DETAILED STEPS

	Command or Action	Purpose
Step 1	<b>enable</b>  <b>Example:</b> Router> enable	Enables privileged EXEC mode. <ul style="list-style-type: none"> <li>• Enter your password if prompted.</li> </ul>
Step 2	<b>configure terminal</b>  <b>Example:</b> Router# configure terminal	Enters global configuration mode.
Step 3	<b>pseudowire-class</b> <i>name</i>  <b>Example:</b> Router(config)# pseudowire-class class1	Establishes a pseudowire class with a name that you specify and enters pseudowire class configuration mode.

	Command or Action	Purpose
Step 4	<b>encapsulation {mpls   l2tpv3}</b>  <b>Example:</b> <pre>Router(config-pw)# encapsulation mpls</pre>	Specifies the tunneling encapsulation, which is either <b>mpls</b> or <b>l2tpv3</b> . <ul style="list-style-type: none"> <li>For the L2VPN Interworking: VLAN Enable/Disable option for AToM feature, only MPLS encapsulation is supported.</li> </ul>
Step 5	<b>interworking {ethernet   ip  vlan}</b>  <b>Example:</b> <pre>Router(config-pw)# interworking vlan</pre>	Specifies the type of pseudowire and the type of traffic that can flow across it. <ul style="list-style-type: none"> <li>For the L2VPN Interworking: VLAN Enable/Disable option for AToM feature, specify the <b>vlan</b> keyword.</li> </ul>
Step 6	<b>end</b>  <b>Example:</b> <pre>Router(config-pw)# end</pre>	Exits pseudowire class configuration mode and enters privileged EXEC mode.
Step 7	<b>show mpls l2transport vc [vcid vc-id   vcid vc-id-min vc-id-max] [interface type number [local-circuit-id]] [destination ip-address   name] [detail]</b>  <b>Example:</b> <pre>Router# show mpls l2transport vc detail</pre>	Displays information about AToM VCs.

## Examples

When the pseudowire on an interface is different from the VC type, the interworking type is displayed in the **show mpls l2transport vc detail** command output. In the following example, the pseudowire is configured on an Ethernet port and VLAN interworking is configured in the pseudowire class. The relevant output is shown in bold:

```
PE1# show mpls l2 vc 34 detail
Local interface: Et0/1 up, line protocol up, Ethernet up
MPLS VC type is Ethernet, interworking type is Eth VLAN
Destination address: 10.1.1.2, VC ID: 34, VC status: down
Output interface: if-?(0), imposed label stack {}
Preferred path: not configured
Default path: no route
No adjacency
Create time: 00:00:13, last status change time: 00:00:13
Signaling protocol: LDP, peer unknown
Targeted Hello: 10.1.1.1(LDP Id) -> 10.1.1.2
Status TLV support (local/remote) : enabled/None (no remote binding)
LDP route watch : enabled
Label/status state machine : local standby, AC-ready, LnuRnd
Last local dataplane status rcvd: No fault
Last local SSS circuit status rcvd: No fault
```



```
Last local SSS circuit status sent: Not sent
Last local LDP TLV status sent: None
Last remote LDP TLV status rcvd: None (no remote binding)
Last remote LDP ADJ status rcvd: None (no remote binding)
MPLS VC labels: local 2003, remote unassigned
Group ID: local 0, remote unknown
MTU: local 1500, remote unknown
Remote interface description:
Sequencing: receive disabled, send disabled
VC statistics:
packet totals: receive 0, send 0
byte totals: receive 0, send 0
packet drops: receive 0, seq error 0, send 0
```

# Configuration Examples for L2VPN Interworking

## Ethernet to VLAN over L2TPV3 (Bridged) Example

The following example shows the configuration of Ethernet to VLAN over L2TPv3:

PE1	PE2
<pre> ip cef  ! l2tp-class interworking-class  authentication  hostname PE1 password 0 lab  ! pseudowire-class inter-ether-vlan  encapsulation l2tpv3 interworking ethernet protocol l2tpv3 interworking-class ip local interface Loopback0  ! interface Loopback0 ip address 10.8.8.8 255.255.255.255  ! interface FastEthernet1/0 xconnect 10.9.9.9 1 pw-class inter-ether-vlan </pre>	<pre> ip cef  ! l2tp-class interworking-class  authentication  hostname PE2 password 0 lab  ! pseudowire-class inter-ether-vlan encapsulation l2tpv3 interworking ethernet protocol l2tpv3 interworking-class ip local interface Loopback0  ! interface Loopback0 ip address 10.9.9.9 255.255.255.255  ! interface FastEthernet0/0 no ip address  ! interface FastEthernet0/0.3 encapsulation dot1Q 10 xconnect 10.8.8.8 1 pw-class inter-ether-vlan </pre>

## Ethernet to VLAN over AToM (Bridged) Example

The following example shows the configuration of Ethernet to VLAN over AToM:

PE1	PE2
<pre> ip cef  !  mpls label protocol ldp mpls ldp router-id Loopback0 force  !  pseudowire-class atom-eth-iw   encapsulation mpls   interworking ethernet  !  interface Loopback0 ip address 10.8.8.8 255.255.255.255  !  interface FastEthernet1/0.1   encapsulation dot1q 100   xconnect 10.9.9.9 123 pw-class atom-eth-iw </pre>	<pre> ip cef  !  mpls label protocol ldp mpls ldp router-id Loopback0 force  !  pseudowire-class atom   encapsulation mpls  !  interface Loopback0   ip address 10.9.9.9 255.255.255.255  !  interface FastEthernet0/0   no ip address  !  interface FastEthernet1/0   xconnect 10.9.9.9 123 pw-class atom </pre>

## Frame Relay to VLAN over L2TPV3 (Routed) Example

The following example shows the configuration of Frame Relay to VLAN over L2TPv3:

PE1	PE2
<pre> configure terminal ip cef frame-relay switching ! ! interface loopback 0 ip address 10.8.8.8 255.255.255.255 no shutdown ! pseudowire-class ip  encapsulation l2tpv3  interworking ip  ip local interface loopback0 ! interface POS1/0  encapsulation frame-relay  clock source internal  logging event dlci-status-change  no shutdown  no fair-queue ! connect fr-vlan POS1/0 206 l2transport  xconnect 10.9.9.9 6 pw-class ip ! router ospf 10  network 10.0.0.2 0.0.0.0 area 0  network 10.8.8.8 0.0.0.0 area 0 </pre>	<pre> configure terminal ip routing ip cef frame-relay switching ! ! interface loopback 0 ip address 10.9.9.9 255.255.255.255 no shutdown ! pseudowire-class ip  encapsulation l2tpv3  interworking ip  ip local interface loopback0 ! interface FastEthernet1/0/1  speed 10  no shutdown ! interface FastEthernet1/0/1.6  encapsulation dot1Q 6  xconnect 10.8.8.8 6 pw-class ip  no shutdown ! router ospf 10  network 10.0.0.2 0.0.0.0 area 0  network 10.9.9.9 0.0.0.0 area 0 </pre>

## Frame Relay to VLAN over AToM (Routed) Example

The following example shows the configuration of Frame Relay to VLAN over AToM:

PE1	PE2
<pre> configure terminal ip cef frame-relay switching ! mpls label protocol ldp mpls ldp router-id loopback0 mpls ip ! pseudowire-class atom   encapsulation mpls   interworking ip ! interface loopback 0   ip address 10.8.8.8 255.255.255.255   no shutdown ! connect fr-vlan POS1/0 206 12transport   xconnect 10.9.9.9 6 pw-class atom </pre>	<pre> configure terminal ip routing ip cef frame-relay switching ! mpls label protocol ldp mpls ldp router-id loopback0 mpls ip ! pseudowire-class atom   encapsulation mpls   interworking ip ! interface loopback 0   ip address 10.9.9.9 255.255.255.255   no shutdown ! interface FastEthernet1/0/1.6   encapsulation dot1Q 6   xconnect 10.8.8.8 6 pw-class atom   no shutdown </pre>

## Frame Relay to ATM AAL5 over AToM (Routed) Example

**Note**

Frame Relay to ATM AAL5 is available only with AToM in IP mode.

The following example shows the configuration of Frame Relay to ATM AAL5 over AToM:

PE1	PE2
<pre> ip cef frame-relay switching mpls ip mpls label protocol ldp mpls ldp router-id loopback0 force pseudowire-class fratmip encapsulation mpls interworking ip interface Loopback0 ip address 10.33.33.33 255.255.255.255 interface serial 2/0 encapsulation frame-relay ietf frame-relay intf-type dce connect fr-eth serial 2/0 100 l2transport xconnect 10.22.22.22 333 pw-class fratmip interface POS1/0 ip address 10.1.7.3 255.255.255.0 crc 32 clock source internal mpls ip mpls label protocol ldp router ospf 10 passive-interface Loopback0 network 10.33.33.33 0.0.0.0 area 10 network 10.1.7.0 0.0.0.255 area 10 </pre>	<pre> ip cef mpls ip mpls label protocol ldp mpls ldp router-id loopback0 force pseudowire-class fratmip encapsulation mpls interworking ip interface Loopback0 ip address 10.22.22.22 255.255.255.255 interface ATM 2/0 pvc 0/203 l2transport encapsulation aa5snap xconnect 10.33.33.33 333 pw-class fratmip interface POS1/0 ip address 10.1.1.2 255.255.255.0 crc 32 clock source internal mpls ip mpls label protocol ldp router ospf 10 passive-interface Loopback0 network 10.22.22.22 0.0.0.0 area 10 network 10.1.1.0 0.0.0.255 area 10 </pre>

## VLAN to ATM AAL5 over AToM (Bridged) Example

The following example shows the configuration of VLAN to ATM AAL5 over AToM:

PE1	PE2
<pre> ip cef ! mpls ip mpls label protocol ldp mpls ldp router-id Loopback0 ! pseudowire-class inter-ether encapsulation mpls interworking ethernet ! interface Loopback0  ip address 10.8.8.8 255.255.255.255 ! interface ATM1/0.1 point-to-point pvc 0/100 l2transport encapsulation aal5snap xconnect 10.9.9.9 123 pw-class inter-ether ! interface FastEthernet1/0 xconnect 10.9.9.9 1 pw-class inter-ether ! router ospf 10  log-adjacency-changes  network 10.8.8.8 0.0.0.0 area 0  network 10.1.1.1 0.0.0.0 area 0 </pre>	<pre> ip cef ! mpls ip mpls label protocol ldp mpls ldp router-id Loopback0 ! pseudowire-class inter-ether  encapsulation mpls  interworking ethernet ! interface Loopback0  ip address 10.9.9.9 255.255.255.255 ! interface FastEthernet0/0  no ip address ! interface FastEthernet0/0.1 encapsulation dot1Q 10 xconnect 10.8.8.8 123 pw-class inter-ether ! router ospf 10  log-adjacency-changes  network 10.9.9.9 0.0.0.0 area 0  network 10.1.1.2 0.0.0.0 area 0 </pre>

## Frame Relay to PPP over L2TPv3 (Routed) Example

The following example shows the configuration of Frame Relay to PPP over L2TPv3:

PE1	PE2
<pre> ip cef ip routing ! ! ! pseudowire-class ppp-fr encapsulation l2tpv3 interworking ip ip local interface Loopback0 ! interface Loopback0  ip address 10.1.1.1 255.255.255.255 ! interface FastEthernet1/0/0  ip address 10.16.1.1 255.255.255.0 ! interface Serial3/0/0 no ip address encapsulation ppp ppp authentication chap ! ip route 10.0.0.0 255.0.0.0 10.16.1.2 ! xconnect 10.2.2.2 1 pw-class ppp-fr ppp ipcp address proxy 10.65.32.14 </pre>	<pre> ip cef ip routing ! frame-relay switching ! pseudowire-class ppp-fr encapsulation l2tpv3 interworking ip ip local interface Loopback0 ! interface Loopback0  ip address 10.2.2.2 255.255.255.255 ! interface FastEthernet1/0/0  ip address 10.16.2.1 255.255.255.0 ! interface Serial3/0/0 no ip address encapsulation frame-relay frame-relay intf-type dce ! ip route 10.0.0.0 255.0.0.0 10.16.2.2 ! connect ppp-fr Serial3/0/0 100 l2transport xconnect 10.1.1.1 100 pw-class ppp-fr </pre>



## Frame Relay to PPP over AToM (Routed) Example

The following example shows the configuration of Frame Relay to PPP over AToM:

PE1	PE2
<pre> ip cef ip routing mpls label protocol ldp mpls ldp router-id loopback0 force ! ! ! pseudowire-class ppp-fr encapsulation mpls interworking ip ip local interface Loopback0 ! interface Loopback0  ip address 10.1.1.1 255.255.255.255 ! interface FastEthernet1/0/0 ip address 10.16.1.1 255.255.255.0 mpls ip label protocol ldp ! interface Serial3/0/0  no ip address  encapsulation ppp  ppp authentication chap  xconnect 10.2.2.2 1 pw-class ppp-fr ppp ipcp address proxy 10.65.32.14 ! ip route 10.0.0.0 255.0.0.0 10.16.1.2 </pre>	<pre> ip cef ip routing mpls label protocol ldp mpls ldp router-id loopback0 force ! ! frame-relay switching ! pseudowire-class ppp-fr encapsulation mpls interworking ip ip local interface Loopback0 ! interface Loopback0  ip address 10.2.2.2 255.255.255.255 ! interface FastEthernet1/0/0 ip address 10.16.2.1 255.255.255.0 mpls ip mpls label protocol ldp ! interface Serial3/0/0  no ip address  encapsulation frame-relay  frame-relay intf-type dce ! ip route 10.0.0.0 255.0.0.0 10.16.2.2 ! connect ppp-fr Serial3/0/0 100 l2transport  xconnect 10.1.1.1 100 pw-class ppp-fr </pre>

## Ethernet VLAN to PPP over AToM (Routed) Example

The following example shows the configuration of Ethernet VLAN to PPP over AToM:

PE1	PE2
<pre> configure terminal mpls label protocol ldp mpls ldp router-id Loopback0 mpls ip ! pseudowire-class ppp-ether   encapsulation mpls   interworking ip ! interface Loopback0   ip address 10.8.8.8 255.255.255.255   no shutdown ! interface POS2/0/1   no ip address   encapsulation ppp   no peer default ip address   ppp ipcp address proxy 10.10.10.1   xconnect 10.9.9.9 300 pw-class ppp-ether  no shutdown </pre>	<pre> configure terminal mpls label protocol ldp mpls ldp router-id Loopback0 mpls ip ! pseudowire-class ppp-ether   encapsulation mpls   interworking ip ! interface Loopback0   ip address 10.9.9.9 255.255.255.255   no shutdown ! interface vlan300   mtu 4470   no ip address   xconnect 10.8.8.8 300 pw-class ppp-ether  no shutdown ! interface GigabitEthernet6/2   switchport   switchport trunk encapsulation dot1q   switchport trunk allowed vlan 300   switchport mode trunk  no shutdown </pre>

## Additional References

The following sections provide references related to the L2VPN Interworking feature.

**Related Documents**

Related Topic	Document Title
Layer 2 Tunnel Protocol Version 3	Layer 2 Tunnel Protocol Version 3
Any Transport over MPLS	Any Transport over MPLS
Cisco 12000 series routers hardware support	<a href="http://www.cisco.com/univercd/cc/td/doc/product/core/cis12000/linecard/lc_spa/spa_swcs/1232sy/index.htm">http://www.cisco.com/univercd/cc/td/doc/product/core/cis12000/linecard/lc_spa/spa_swcs/1232sy/index.htm</a> <a href="http://www.cisco.com/en/US/products/sw/iosswrel/ps1829/prod_release_notes_list.html">http://www.cisco.com/en/US/products/sw/iosswrel/ps1829/prod_release_notes_list.html</a> Cross-Platform Release Notes for Cisco IOS Release 12.0S.
Cisco 7600 series routers hardware support	<ul style="list-style-type: none"> <li>• <a href="#">Release Notes for Cisco IOS Release 12.2SR for the Cisco 7600 Series Routers</a></li> </ul>
Cisco 3270 series routers hardware support	<a href="#">Cisco IOS Software Releases 12.2SE Release Notes</a>

**Standards**

Standards	Title
draft-ietf-l2tpext-l2tp-base-03.txt	<i>Layer Two Tunneling Protocol (Version 3) 'L2TPv3'</i>
draft-martini-l2circuit-trans-mpls-09.txt	<i>Transport of Layer 2 Frames Over MPLS</i>
draft-ietf-pwe3-frame-relay-03.txt.	<i>Encapsulation Methods for Transport of Frame Relay over MPLS Networks</i>
draft-martini-l2circuit-encap-mpls-04.txt.	<i>Encapsulation Methods for Transport of Layer 2 Frames Over IP and MPLS Networks</i>
draft-ietf-pwe3-ethernet-encap-08.txt.	<i>Encapsulation Methods for Transport of Ethernet over MPLS Networks</i>
draft-ietf-pwe3-hdlc-ppp-encap-mpls-03.txt.	<i>Encapsulation Methods for Transport of PPP/HDLC over MPLS Networks</i>
draft-ietf-ppvnpn-l2vpn-00.txt.	<i>An Architecture for L2VPNs</i>

**MIBs**

MIBs	MIBs Link
No new or modified MIBs are supported by this feature, and support for existing MIBs has not been modified by this feature.	To locate and download MIBs for selected platforms, Cisco IOS releases, and feature sets, use Cisco MIB Locator found at the following URL:  <a href="http://www.cisco.com/go/mibs">http://www.cisco.com/go/mibs</a>

**RFCs**

RFCs	Title
No new or modified RFCs are supported by this feature, and support for existing RFCs has not been modified by this feature.	--

**Technical Assistance**

Description	Link
<p>The Cisco Support website provides extensive online resources, including documentation and tools for troubleshooting and resolving technical issues with Cisco products and technologies.</p> <p>To receive security and technical information about your products, you can subscribe to various services, such as the Product Alert Tool (accessed from Field Notices), the Cisco Technical Services Newsletter, and Really Simple Syndication (RSS) Feeds.</p> <p>Access to most tools on the Cisco Support website requires a Cisco.com user ID and password.</p>	<a href="http://www.cisco.com/techsupport">http://www.cisco.com/techsupport</a>

## Feature Information for L2VPN Interworking

The following table provides release information about the feature or features described in this module. This table lists only the software release that introduced support for a given feature in a given software release train. Unless noted otherwise, subsequent releases of that software release train also support that feature.

Use Cisco Feature Navigator to find information about platform support and Cisco software image support. To access Cisco Feature Navigator, go to [www.cisco.com/go/cfn](http://www.cisco.com/go/cfn). An account on Cisco.com is not required.

**Table 6: Feature Information for L2VPN Interworking**

Feature Name	Releases	Feature Information
L2VPN Interworking	12.0(26)S 12.0(30)S 12.0(32)S 12.0(32)SY 12.2(33)SRA 12.4(11)T 12.2(33)SXH 12.2(33)SRD 12.2(52)SE 12.2(33)SRE	

Feature Name	Releases	Feature Information
		<p>This feature allows disparate attachment circuits to be connected. An interworking function facilitates the translation between the different Layer 2 encapsulations.</p> <p>This feature was introduced in Cisco IOS Release 12.0(26)S.</p> <p>In Cisco IOS Release 12.0(30)S, support was added for Cisco 12000 series Internet routers.</p> <p>In Cisco IOS Release 12.0(32)S, support was added on Engine 5 line cards (SIP-401, SIP-501, SIP-600, and SIP-601) in Cisco 12000 series routers for the following four transport types:</p> <ul style="list-style-type: none"> <li>• Ethernet/VLAN to Frame Relay Interworking</li> <li>• Ethernet/VLAN to ATM AAL5 Interworking</li> <li>• Ethernet to VLAN Interworking</li> <li>• Frame Relay to ATM AAL5 Interworking</li> </ul> <p>On the Cisco 12000 series Internet router, support was added for IP Services Engine (ISE) and Engine 5 line cards that are configured for L2TPv3 tunneling.</p> <p>In Cisco IOS Release 12.2(33)SRA, support was added for the Cisco 7600 series routers.</p> <p>In Cisco IOS Release 12.4(11)T, support was added for the following transport types:</p> <ul style="list-style-type: none"> <li>• Ethernet to VLAN Interworking</li> <li>• Ethernet/VLAN to Frame Relay Interworking</li> </ul> <p>This feature was integrated into Cisco IOS Release 12.2(33)SXH.</p>

Feature Name	Releases	Feature Information
		<p>In Cisco IOS Release 12.2(33)SRD, support for routed and bridged interworking on SIP-400 was added for the Cisco 7600 series routers.</p> <p>In Cisco IOS Release 12.2(52)SE, the L2VPN Internetworking: VLAN Enable/Disable option for AToM feature was added for the Cisco 3750 Metro switch.</p> <p>In Cisco IOS Release 12.2(33)SRE, the L2VPN Internetworking: VLAN Enable/Disable option for AToM feature was added for the Cisco 7600 series router.</p> <p>The following commands were introduced or modified: <b>interworking</b></p>

