



## **QoS: IP to ATM Class of Service Configuration Guide, Cisco IOS Release 15M&T**

**First Published:** February 20, 2013

**Last Modified:** February 20, 2013

### **Americas Headquarters**

Cisco Systems, Inc.  
170 West Tasman Drive  
San Jose, CA 95134-1706  
USA  
<http://www.cisco.com>  
Tel: 408 526-4000  
800 553-NETS (6387)  
Fax: 408 527-0883

THE SPECIFICATIONS AND INFORMATION REGARDING THE PRODUCTS IN THIS MANUAL ARE SUBJECT TO CHANGE WITHOUT NOTICE. ALL STATEMENTS, INFORMATION, AND RECOMMENDATIONS IN THIS MANUAL ARE BELIEVED TO BE ACCURATE BUT ARE PRESENTED WITHOUT WARRANTY OF ANY KIND, EXPRESS OR IMPLIED. USERS MUST TAKE FULL RESPONSIBILITY FOR THEIR APPLICATION OF ANY PRODUCTS.

THE SOFTWARE LICENSE AND LIMITED WARRANTY FOR THE ACCOMPANYING PRODUCT ARE SET FORTH IN THE INFORMATION PACKET THAT SHIPPED WITH THE PRODUCT AND ARE INCORPORATED HEREIN BY THIS REFERENCE. IF YOU ARE UNABLE TO LOCATE THE SOFTWARE LICENSE OR LIMITED WARRANTY, CONTACT YOUR CISCO REPRESENTATIVE FOR A COPY.

The Cisco implementation of TCP header compression is an adaptation of a program developed by the University of California, Berkeley (UCB) as part of UCB's public domain version of the UNIX operating system. All rights reserved. Copyright © 1981, Regents of the University of California.

NOTWITHSTANDING ANY OTHER WARRANTY HEREIN, ALL DOCUMENT FILES AND SOFTWARE OF THESE SUPPLIERS ARE PROVIDED "AS IS" WITH ALL FAULTS. CISCO AND THE ABOVE-NAMED SUPPLIERS DISCLAIM ALL WARRANTIES, EXPRESSED OR IMPLIED, INCLUDING, WITHOUT LIMITATION, THOSE OF MERCHANTABILITY, FITNESS FOR A PARTICULAR PURPOSE AND NON-INFRINGEMENT OR ARISING FROM A COURSE OF DEALING, USAGE, OR TRADE PRACTICE.

IN NO EVENT SHALL CISCO OR ITS SUPPLIERS BE LIABLE FOR ANY INDIRECT, SPECIAL, CONSEQUENTIAL, OR INCIDENTAL DAMAGES, INCLUDING, WITHOUT LIMITATION, LOST PROFITS OR LOSS OR DAMAGE TO DATA ARISING OUT OF THE USE OR INABILITY TO USE THIS MANUAL, EVEN IF CISCO OR ITS SUPPLIERS HAVE BEEN ADVISED OF THE POSSIBILITY OF SUCH DAMAGES.

Any Internet Protocol (IP) addresses and phone numbers used in this document are not intended to be actual addresses and phone numbers. Any examples, command display output, network topology diagrams, and other figures included in the document are shown for illustrative purposes only. Any use of actual IP addresses or phone numbers in illustrative content is unintentional and coincidental.

Cisco and the Cisco logo are trademarks or registered trademarks of Cisco and/or its affiliates in the U.S. and other countries. To view a list of Cisco trademarks, go to this URL: <http://www.cisco.com/go/trademarks>. Third-party trademarks mentioned are the property of their respective owners. The use of the word partner does not imply a partnership relationship between Cisco and any other company. (1110R)

© 2014 Cisco Systems, Inc. All rights reserved.



## **CONTENTS**

---

### **CHAPTER 1**

#### **IP to ATM Class of Service Overview 1**

- Finding Feature Information 1
- About IP to ATM CoS 1
  - Single ATM VC Support 2
  - VC Bundle Support and Bundle Management 3
  - Per-VC LLQ WFQ and CBWFQ Support 4
- Why Use IP to ATM CoS 5
  - Benefits 5
- IP to ATM CoS Features 6
  - Congestion Avoidance 6
  - Bumping and ATM VC Bundles 7
  - Restrictions 8

---

### **CHAPTER 2**

#### **Configuring IP to ATM Class of Service 11**

- Finding Feature Information 11
- IP to ATM CoS on a Single ATM VC Configuration Task List 11
  - Defining the WRED Parameter Group 12
  - Configuring the WRED Parameter Group 12
  - Displaying the WRED Parameters 12
  - Displaying the Queueing Statistics 13
- IP to ATM CoS on an ATM Bundle Configuration Task List 13
  - Creating a VC Bundle 13
  - Applying Bundle-Level Parameters 14
    - Configuring Bundle-Level Parameters 14
    - Configuring VC Class Parameters to Apply to a Bundle 15
    - Attaching a Class to a Bundle 15
  - Committing a VC to a Bundle 15
  - Applying Parameters to Individual VCs 16

|  |    |
|--|----|
| Configuring a VC Bundle Member Directly                        | 16 |
| Configuring VC Class Parameters to Apply to a VC Bundle Member | 17 |
| Applying a VC Class to a Discrete VC Bundle Member             | 17 |
| Configuring a VC Not to Accept Bumped Traffic                  | 17 |
| Monitoring and Maintaining VC Bundles and Their VC Members     | 18 |
| Per-VC WFQ and CBWFQ Configuration Task List                   | 18 |
| Configuring Class-Based Weighted Fair Queueing                 | 18 |
| Attaching a Service Policy and Enabling CBWFQ for a VC         | 19 |
| Attaching a Policy Map to a Standalone VC and Enabling CBWFQ   | 19 |
| Attaching a Policy Map to an Individual VC and Enabling CBWFQ  | 19 |
| Configuring a VC to Use Flow-Based WFQ                         | 20 |
| Attaching a Policy Map to a Standalone VC and Enabling WFQ     | 21 |
| Attaching a Policy Map to an Individual VC and Enabling WFQ    | 21 |
| Monitoring per-VC WFQ and CBWFQ                                | 21 |
| Enabling Logging of Error Messages to the Console              | 21 |
| IP to ATM CoS Configuration Examples                           | 22 |
| Example Single ATM VC with WRED Group and IP Precedence        | 22 |
| Example VC Bundle Configuration Using a VC Class               | 22 |
| Bundle-Class Class   | 22 |
| Control-Class Class  | 23 |
| Premium-Class Class  | 23 |
| Priority-Class Class   | 23 |
| Basic-Class Class  | 23 |
| new-york Bundle  | 24 |
| san-francisco Bundle   | 24 |
| los-angeles Bundle   | 25 |
| Example Per-VC WFQ and CBWFQ on a Standalone VC                | 25 |
| Example Per-VC WFQ and CBWFQ on Bundle-Member VCs              | 26 |

**CHAPTER 3****IP to ATM Class of Service Mapping for SVC Bundles 27**

|                                   |    |
|-----------------------------------|----|
| Finding Feature Information       | 27 |
| Feature Overview                  | 28 |
| Benefits                          | 28 |
| Restrictions                      | 28 |
| Related Features and Technologies | 28 |

|   |    |
|---|----|
| Related Documents   | 28 |
| Supported Platforms   | 29 |
| Supported Standards MIBs and RFCs   | 29 |
| Prerequisites   | 30 |
| Configuration Tasks   | 30 |
| Creating an SVC Bundle  | 30 |
| Configuring Bundle-Level Parameters                                       | 31 |
| Attaching a Class to a Bundle   | 31 |
| Configuring an SVC Bundle Member Directly                                 | 31 |
| Monitoring IP to ATM Class of Service Mapping for SVC Bundles             | 32 |
| Configuration Examples  | 33 |
| Example IP to ATM Class of Service Mapping in Bundle Mode                 | 33 |
| Example IP to ATM Class of Service Mapping Using the class-bundle Command | 34 |

---

**CHAPTER 4****ATM PVC Bundle Enhancement MPLS EXP-Based PVC Selection 35**

|  |    |
|--|----|
| Finding Feature Information                          | 35 |
| Feature Overview                                     | 36 |
| VC Bundle Support and Bundle Management              | 36 |
| Benefits   | 37 |
| Restrictions   | 38 |
| Related Features and Technologies                    | 38 |
| Related Documents                                    | 38 |
| Supported Platforms                                  | 38 |
| Supported Standards MIBs and RFCs                    | 39 |
| Configuration Tasks                                  | 39 |
| Enabling MPLS  | 40 |
| Creating a VC Bundle                                 | 40 |
| Applying Parameters to Bundles                       | 41 |
| Configuring Bundle-Level Parameters                  | 41 |
| Configuring a VC Bundle Member Directly              | 41 |
| Configuring VC Class Parameters to Apply to a Bundle | 42 |
| Attaching a Class to a Bundle                        | 42 |
| Verifying the Configuration                          | 42 |
| Configuration Examples                               | 43 |
| Example VC Bundle Configuration Using a VC Class     | 43 |

|                      |    |
|----------------------|----|
| Bundle-Class Class   | 43 |
| Control-Class Class  | 43 |
| Premium-Class Class  | 43 |
| Priority-Class Class | 44 |
| Basic-Class Class    | 44 |
| new-york Bundle      | 44 |
| san-francisco Bundle | 45 |
| los-angeles Bundle   | 45 |
| Command Reference    | 46 |



## CHAPTER

# 1

## IP to ATM Class of Service Overview

---

This module provides a high-level overview of IP to ATM Class of Service (CoS), a feature suite that maps QoS characteristics between IP and ATM.

- [Finding Feature Information, page 1](#)
- [About IP to ATM CoS, page 1](#)
- [Why Use IP to ATM CoS, page 5](#)
- [IP to ATM CoS Features, page 6](#)
- [Congestion Avoidance, page 6](#)
- [Bumping and ATM VC Bundles, page 7](#)
- [Restrictions, page 8](#)

### Finding Feature Information

Your software release may not support all the features documented in this module. For the latest caveats and feature information, see [Bug Search Tool](#) and the release notes for your platform and software release. To find information about the features documented in this module, and to see a list of the releases in which each feature is supported, see the feature information table at the end of this module.

Use Cisco Feature Navigator to find information about platform support and Cisco software image support. To access Cisco Feature Navigator, go to [www.cisco.com/go/cfn](http://www.cisco.com/go/cfn). An account on Cisco.com is not required.

### About IP to ATM CoS

The IP to ATM CoS feature implements a solution for coarse-grained mapping of QoS characteristics between IP and ATM, using Cisco Enhanced ATM port adapters (PA-A3) on Cisco 7200 and Cisco 7500 series routers. (This category of coarse-grained QoS is often referred to as CoS). The resulting feature makes it possible to support differential services in network service provider environments.

IP to ATM CoS is designed to provide a true working solution to class-based services, without the investment of new ATM network infrastructures. Now networks can offer different service classes (sometimes termed *differential service classes*) across the entire WAN, not just the routed portion. Mission-critical applications

can be given exceptional service during periods of high network usage and congestion. In addition, noncritical traffic can be restricted in its network usage, which ensures greater QoS for more important traffic and user types.

The IP to ATM CoS feature is supported on Cisco 2600, Cisco 3600, Cisco 7200, and Cisco 7500 series routers equipped with the following hardware:

- Cisco 2600 and Cisco 3600 series: ATM OC-3, T1 IMA, or E1 IMA port adapter
- Cisco 7200 series:
  - NPE-200 or higher (NPE-300 recommended for per-virtual circuit (VC) class-based weighted fair queuing (CBWFQ))
  - One of the following Enhanced ATM port adapters (PA-A3): T3, E3, DS3, or OC-3
- Cisco 7500 series:
  - VIP2-50
  - One of the following Enhanced ATM port adapters (PA-A3): T3, E3, DS3, or OC-3

IP to ATM CoS supports configuration of the following features:

## Single ATM VC Support

IP to ATM CoS support for a single ATM VC allows network managers to use existing features, such as committed access rate (CAR) or policy-based routing (PBR), to classify and mark different IP traffic by modifying the IP Precedence field in the IP version 4 (IPv4) packet header. Subsequently, Weighted Random Early Detection (WRED) or distributed WRED (DWRED) can be configured on a per-VC basis so that the IP traffic is subject to different drop probabilities (and therefore priorities) as IP traffic coming into a router competes for bandwidth on a particular VC.

Enhanced ATM port adapters (PA-A3) provide the ability to shape traffic on each VC according to the ATM service category and traffic parameters employed. When you use the IP to ATM CoS feature, congestion is managed entirely at the IP layer by WRED running on the routers at the edge of the ATM network.

The figure below illustrates the IP to ATM CoS support for a single ATM VC.

**Figure 1: Single ATM Circuit Class**

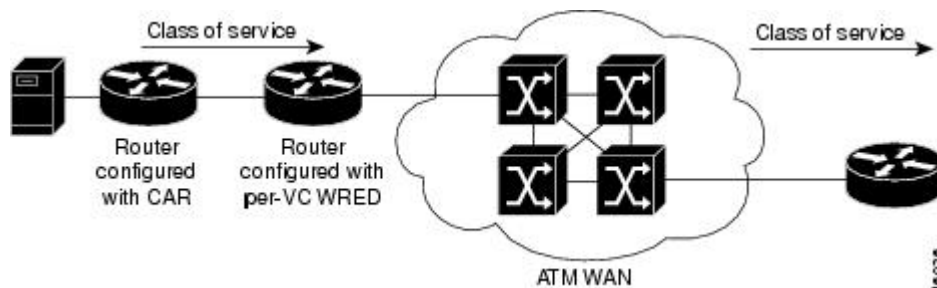



## VC Bundle Support and Bundle Management

ATM VC bundle management allows you to configure multiple VCs that have different QoS characteristics between any pair of ATM-connected routers. As shown in the figure below, these VCs are grouped in a bundle and are referred to as bundle members.

**Figure 2: ATM VC Bundle**

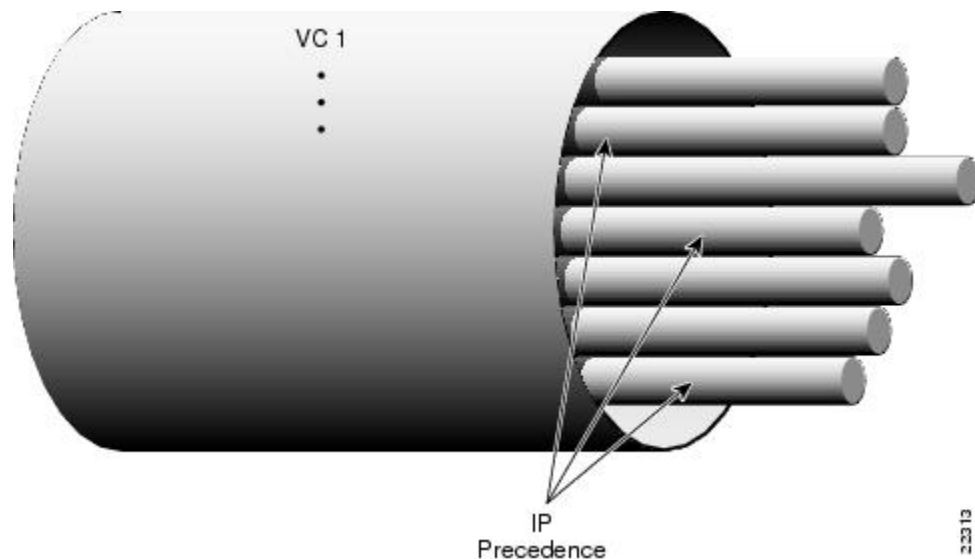

ATM VC bundle management allows you to define an ATM VC bundle and add VCs to it. Each VC of a bundle has its own ATM traffic class and ATM traffic parameters. You can apply attributes and characteristics to discrete VC bundle members or you can apply them collectively at the bundle level.

Using VC bundles, you can create differentiated service by flexibly distributing IP precedence levels over the different VC bundle members. You can map a single precedence level or a range of levels to each discrete VC in the bundle, thereby enabling individual VCs in the bundle to carry packets marked with different precedence levels. You can use WRED (or DWRED) to further differentiate service across traffic that has different IP precedences but that uses the same VC in a bundle.

To determine which VC in the bundle to use to forward a packet to its destination, the ATM VC bundle management software matches precedence levels between packets and VCs (see the figure below). IP traffic is sent to the next hop address for the bundle because all VCs in a bundle share the same destination, but the VC used to carry a packet depends on the value set for that packet in the IP Precedence bits of the type of service (ToS) byte of its header. The ATM VC bundle management software matches the IP precedence of the packet to the IP Precedence value or range of values assigned to a VC, sending the packet out on the appropriate VC. Moreover, the ATM VC bundle management feature allows you to configure how traffic will be redirected when the VC the packet was matched to goes down. The figure below illustrates how the

ATM VC bundle management software determines which permanent virtual circuit (PVC) bundle member to use to carry a packet and how WRED (or DWRED) is used to differentiate traffic on the same VC.

**Figure 3: ATM VC Bundle PVC Selection for Packet Transfer**

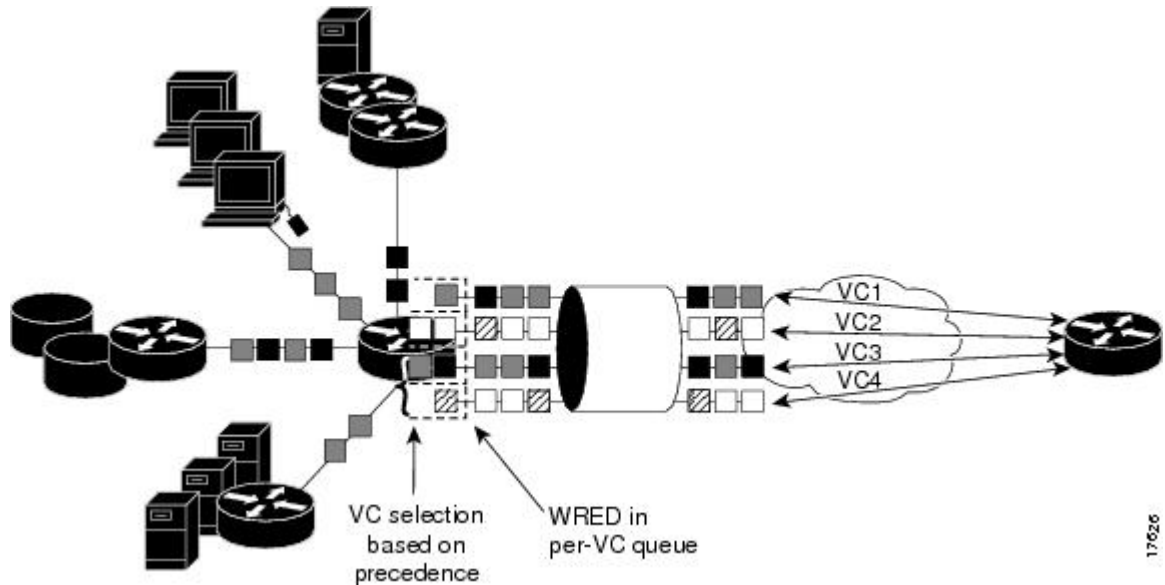

The support of multiple parallel ATM VCs allows you to create stronger service differentiation at the IP layer. For instance, you might want to provide IP traffic belonging to real-time CoS (such as Voice over IP traffic) on an ATM VC with strict constraints (constant bit rate (CBR) or variable bit rate real-time (VBR-rt), for example), while transporting traffic other than real-time traffic over a more elastic ATM available bit rate (ABR) PVC. Using a configuration such as this would allow you to fully utilize your network capacity. You could also elect to transport best-effort IP traffic over an unspecified bit rate (UBR) PVC--UBR is effectively the ATM version of best-effort service.

## Per-VC LLQ WFQ and CBWFQ Support

The IP to ATM CoS feature allows you to apply a policy map to a VC to specify a service policy for that VC so that all traffic sent on that VC is categorized according to the classes and their match criteria defined by the service policy. In other words, IP to ATM CoS takes the functionality defined for standard LLQ, WFQ, and CBWFQ and makes it available for application and use at the discrete VC level.

IP to ATM CoS allows you to configure a single, standalone VC or individual VCs belonging to a bundle. You also can configure collectively all VCs belonging to a bundle. However, for per-VC LLQ, WFQ and CBWFQ, you can configure individual VCs only. That is, you can configure a standalone VC or a VC that belongs to a bundle, but you cannot use per-VC LLQ, WFQ and CBWFQ to configure a bundle of VCs collectively.

Per-VC LLQ, WFQ and CBWFQ allows you to differentiate the use of individual VCs within a bundle. For instance, you can apply one service policy to one VC belonging to a VC bundle and apply a different service policy to another VC belonging to the same bundle. You can also apply the same policy map to multiple VCs--whether standalone or bundle members--but each VC can have only one service policy. To concatenate service policies, you must create a third policy map and include in it all the classes that you want to use from policy maps you would have concatenated.

The following is a summary of how you configure a VC to use CBWFQ:

- You define traffic classes to specify the classification policy (class maps). This process determines how many types of packets are to be differentiated from one another.
- You configure policy maps containing classes that specify the policy for each traffic class.
- You attach a policy map to a VC that uses IP to ATM CoS to specify the service policy for the VC.

To apply flow-based WFQ on a per-VC basis, you configure WFQ in the predefined CBWFQ default class, which is called class-default, but you do not ascribe bandwidth to the default class.

## Why Use IP to ATM CoS

Internet service classes can be identified and sorted within the router network. But as traffic traverses the wide-area ATM fabric, the relative ATM class definitions are not equivalent, and a traffic type may be treated differently in the ATM switching fabric than in the router network; mission-critical applications or data could be dropped during times of network congestion.

The IP to ATM CoS feature uses the Cisco Enhanced ATM port adapter (PA-A3) on Cisco 7500 and Cisco 7200 series routers to provide the ability to map IP CoS and ATM QoS, extending the capability previously available only for IP networks; differentiated services are preserved through the ATM network.

## Benefits

Here are some benefits of using IP to ATM CoS:

- Ensures effective differential classes over IP and traditional ATM networks. For instance, the VC bundle management feature provides for differentiated QoS by allowing for the coexistence of multiple VCs with different QoS characteristics from the same source to the same destination.
- Uses existing ATM infrastructures.
- Implements solutions for coarse-grained mapping of QoS characteristics called CoS between IP and ATM.
- Employs a high-performance design benefiting from distributed processing on the Cisco 7500 series routers and Versatile Interface Processor (VIP).
- Uses the Cisco Enhanced ATM port adapter (PA-A3), which supports traffic shaping and has rich ATM Service Category support. This port adapter (PA) is supported on the Cisco 7500+VIP and Cisco 7200 series routers.
- Provides per-VC queuing on the PA, per-VC back pressure, and per-VC WRED VIP queuing, which bring stability to a network by ensuring that system packets such as Border Gateway Protocol (BGP) and Intermediate System-to-Intermediate System (IS-IS) are never dropped.
- Provides flexible management of the VC bundle on PVC failure.
- Provides CBWFQ functionality at the VC level.

# IP to ATM CoS Features

IP to ATM CoS includes the following features:

- Per-VC queueing infrastructure. This feature enables queues to be maintained on a per-VC basis. Packets are queued and dequeued based on the back pressure from the PA. Use of a queue per VC prevents one or more congested VCs from affecting the traffic flow on other VCs that are not congested.
- Per-VC WRED (or DWRED). This feature applies the WRED algorithm independently to each per-VC queue. The WRED parameters are configurable on a per-VC basis so that congestion management can be configured as appropriate for each VC.
- Per-VC WRED (or DWRED) statistics. This feature maintains per-flow and per-VC statistics based on IP precedence.
- Per-VC LLQ, WFQ and CBWFQ. This feature allows you to apply CBWFQ functionality--normally applicable at the interface or subinterface levels only--to an individual VC configured for IP to ATM CoS. You can use this feature to apply either CBWFQ or flow-based WFQ on a per-VC basis.
- Per-VC traffic policing. This feature allows you to police traffic within a traffic policy, per-VC.

## Congestion Avoidance

For each VC that is created on the Enhanced ATM port adapter (PA-A3), the PA allocates some of the buffers from its buffer pool to that VC in order to create a queue for that VC.

The use of per-VC queues ensures that a direct relationship exists between the outgoing ATM VC and the IP packets to be forwarded on that queue. This mechanism establishes a packet queue for each outgoing ATM VC. In this manner, should an ATM VC become congested, only the packet queue associated with that VC will begin to fill. If the queue overfills, then all other queues remain unaffected. Such a mechanism ensures that an individual VC cannot consume all of the resources of the router should only one of its outgoing VCs be congested or underprovisioned.

Queues for buffering more packets for a particular VC are created in the Layer 3 processor system and are mapped one-to-one to the per-VC queues on the PA. When the PA per-VC queues become congested, they signal back pressure to the Layer 3 processor; the Layer 3 processor can then continue to buffer packets for that VC in the corresponding Layer 3 queue. Furthermore, because the Layer 3 queues are accessible by the Layer 3 processor, a user can run flexible software scheduling algorithms on those queues.

When you transport data over ATM fabrics, it is essential that decisions to discard data (because of insufficient network resources or congestion) be made at the packet level. To do otherwise would be to send incomplete data packets into the ATM fabric, causing the packets to be discarded by either the ATM switched fabric (if it is equipped with early packet discard) or at the remote end where the packet will be reassembled and found to be incomplete.

To initiate effective congestion management techniques, IP to ATM CoS uses per-VC WRED (or DWRED). Per-VC WRED (or DWRED) selectively places TCP sessions in slow start mode to ensure higher aggregate

throughput under congestion. The figure below shows low priority packets being dropped on VC1 because VC1 is congested. In this example, VC2 is not congested and all packets, regardless of priority, are sent.

**Figure 4: Traffic Congestion with IP to ATM CoS and Per-VC WRED**

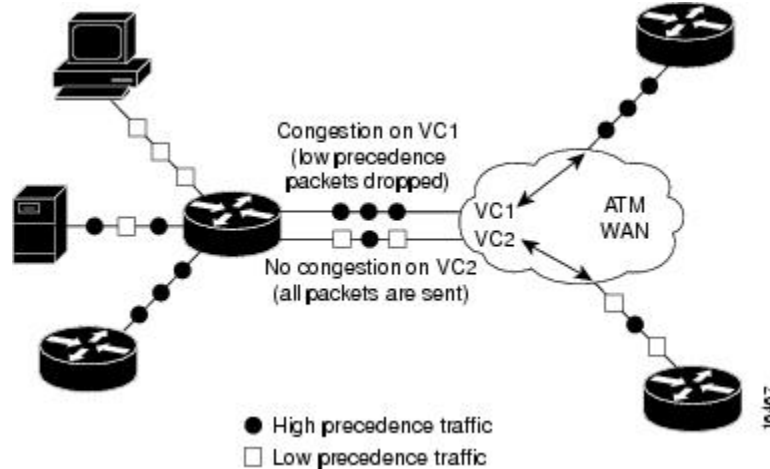

Running the WRED algorithm independently on each per-VC queue provides differentiated QoS to traffic of different IP Precedence values.

## Bumping and ATM VC Bundles

The ATM VC bundle is designed to behave as a single routing link to the destination router while managing the integrity of its group of circuits. The integrity of each circuit is maintained through individual monitoring. Should a circuit fail, appropriate action is taken, in the form of circuit bumping or bundle disabling.

VC integrity is maintained through ATM Operation, Administration, and Maintenance (OAM) polling mechanisms. These mechanisms will determine whether a VC is unavailable or severely congested. Should an individual circuit become unavailable, then the device consults a preset series of rules to determine the course of action to take next. These rules are defined by the Internet service provider (ISP) through configuration parameters.

The figure below conceptualizes a failed VC bundle member whose failure calls into effect the configured bumping rules.

**Figure 5: VC Bundle Member Circuit Failure Enacting Bumping Rules**

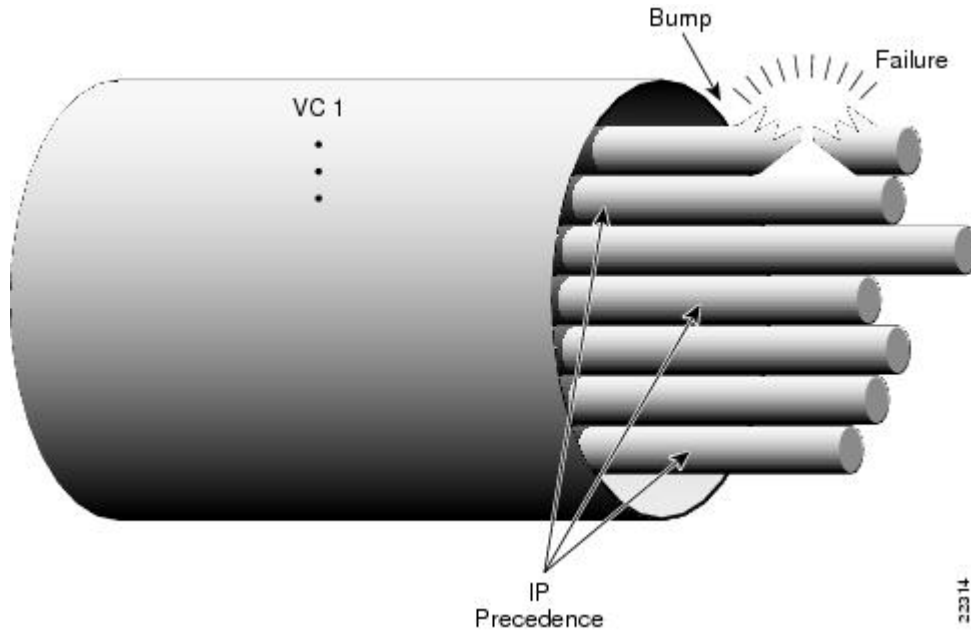

In the event of failure, the router responds with one of two methods. The first method dynamically assigns the traffic bound on the failed VC to an alternative VC, which is termed *circuit bumping*. Bumped traffic is then shared on an existing in-service VC. Traffic typically would be bumped from a higher class to a lower one, although it need not be. For example, should the premium, or first class, data circuit become unavailable, then all premium users would share the second class or general circuit. Preference would then be given to the premium traffic within this shared circuit.

The second method is to declare all circuits of the bundle to be down. In effect, the device is declaring the routed bundle inactive and asking the routing layer to search for an alternate.

The determination of whether to bump or whether to declare the bundle inactive is predefined by the network provider when administering the network configuration.

## Restrictions

The following restrictions apply for IP to ATM CoS:

- IP to ATM CoS supports only PVCs:
  - For PVC connections, it supports multipoint and point-to-point subinterfaces.
  - For PVC encapsulations, it supports only ATM adaptation layer (AAL5), Subnetwork Access Protocol (SNAP), and multiplex device (mux) interfaces.
- IP to ATM CoS does not allow point-to-multipoint VCs in the bundle. All VCs share the same source and destination (target) addresses.

- IP to ATM CoS does not work with the ATM Interface Processor (AIP) and the ATM port adapter (PA-A1).







## Configuring IP to ATM Class of Service

This module describes the tasks for configuring the IP to ATM Class of Service (CoS), a feature suite that maps QoS characteristics between IP and ATM.

Use Cisco Feature Navigator to find information about platform support and software image support. Cisco Feature Navigator enables you to determine which Cisco IOS and Catalyst OS software images support a specific software release, feature set, or platform. To access Cisco Feature Navigator, go to <http://www.cisco.com/go/cfn>. An account on Cisco.com is not required.

- [Finding Feature Information, page 11](#)
- [IP to ATM CoS on a Single ATM VC Configuration Task List, page 11](#)
- [IP to ATM CoS on an ATM Bundle Configuration Task List, page 13](#)
- [Per-VC WFQ and CBWFQ Configuration Task List, page 18](#)
- [IP to ATM CoS Configuration Examples, page 22](#)

### Finding Feature Information

Your software release may not support all the features documented in this module. For the latest caveats and feature information, see [Bug Search Tool](#) and the release notes for your platform and software release. To find information about the features documented in this module, and to see a list of the releases in which each feature is supported, see the feature information table at the end of this module.

Use Cisco Feature Navigator to find information about platform support and Cisco software image support. To access Cisco Feature Navigator, go to [www.cisco.com/go/cfn](http://www.cisco.com/go/cfn). An account on Cisco.com is not required.

### IP to ATM CoS on a Single ATM VC Configuration Task List

To configure IP to ATM CoS for a single ATM virtual circuit (VC), perform the tasks described in the following sections. The tasks in the first two sections are required; the tasks in the remaining sections are optional.

The IP to ATM CoS feature requires ATM permanent virtual circuit (PVC) management.

## Defining the WRED Parameter Group

| Command  | Purpose   |
|--|---|
| Router(config)# <b>random-detect-group</b> <i>group-name</i> | Defines the WRED or VIP-distributed WRED (DWRED) parameter group. |

## Configuring the WRED Parameter Group

### SUMMARY STEPS

1. Router(config)# **random-detect-group** *group-name*
2. Router(config)# **exponential-weighting-constant** *exponent* Router(config)# **precedence** *precedence min-threshold max-threshold mark-probability-denominator*

### DETAILED STEPS

|               | Command or Action  | Purpose  |
|---------------|--|--|
| <b>Step 1</b> | Router(config)# <b>random-detect-group</b> <i>group-name</i>   | Specifies the WRED or DWRED parameter group.   |
| <b>Step 2</b> | Router(config)# <b>exponential-weighting-constant</b> <i>exponent</i> Router(config)# <b>precedence</b> <i>precedence min-threshold max-threshold mark-probability-denominator</i> | Configures the exponential weight factor for the average queue size calculation for the specified WRED or DWRED parameter group.<br><br>or<br>Configures the specified WRED or DWRED parameter group for a particular IP precedence. |

## Displaying the WRED Parameters

| Command   | Purpose   |
|---|---|
| Router# <b>show queueing random-detect</b> [ <i>interface atm_subinterface</i> ] [ <i>vc</i> ] [ <i>[vpi/] vci</i> ]] | Displays the parameters of every VC with WRED or DWRED enabled on the specified ATM subinterface. |

## Displaying the Queueing Statistics

| Command  | Purpose  |
|--|--|
| Router# <b>show queueing interface</b><br><i>interface-number</i> [ <b>vc</b> [[ <i>vpi</i> /] <i>vci</i> ]] | Displays the queueing statistics of a specific VC on an interface. |

## IP to ATM CoS on an ATM Bundle Configuration Task List

To configure IP to ATM CoS on an ATM bundle, perform the tasks in the following sections.

The IP to ATM CoS feature requires ATM PVC management.

### Creating a VC Bundle

| Command   | Purpose  |
|---|--|
| Router(config-subif) # <b>bundle</b> <i>bundle-name</i> | Creates the specified bundle and enters bundle configuration mode. |

## Applying Bundle-Level Parameters

### Configuring Bundle-Level Parameters

| Command  | Purpose   |
|--|---|
| Device(config-atm-bundle)# <b>protocol</b> <i>protocol</i><br>{ <i>protocol-address</i>   <b>inarp</b> } [[ <b>no</b> ] <b>broadcast</b> ] | Configures a static map or enables Inverse Address Resolution Protocol (Inverse ARP) or Inverse ARP broadcasts for the bundle.<br><br><b>Note</b> Bundle-level parameters can be applied either by assigning VC classes or by directly applying them to the bundle. Parameters applied through a VC class assigned to the bundle are superseded by those applied at the bundle level. Bundle-level parameters are superseded by parameters applied to an individual VC. |
| Device(config-atm-bundle)# <b>encapsulation</b><br><i>aal-encap</i>  | Configures the ATM adaptation layer (AAL) and encapsulation type for the bundle.  |
| Device(config-atm-bundle)# <b>inarp</b> <i>minutes</i>   | Configures the Inverse ARP time period for all VC bundle members.   |
| Device(config-atm-bundle)# <b>broadcast</b>  | Enables broadcast forwarding for all VC bundle members.   |
| Device(config-atm-bundle)# <b>oam retry</b> up-count<br>down-count retry frequency   | Configures the VC bundle parameters related to operation, administration, and maintenance (OAM) management.   |
| Device(config-atm-bundle)# <b>oam-bundle</b><br>[ <b>manage</b> ] [ <i>frequency</i> ]   | Enables end-to-end F5 OAM loopback cell generation and OAM management for all VCs in the bundle.  |

## Configuring VC Class Parameters to Apply to a Bundle

| Command   | Purpose  |
|---|--|
| <pre>Router(config-vc-class)# oam-bundle [manage] [frequency]</pre> | <p>Enables end-to-end F5 OAM loopback cell generation and OAM management for all VCs in the bundle.</p> <p><b>Note</b> Use of a VC class allows you to configure a bundle applying multiple attributes to it at once because you apply the class itself to the bundle. Use of a class allows you to generalize a parameter across all VCs, after which (for some parameters) you can modify that parameter for individual VCs. (See the section "Applying Parameters to Individual VCs" for more information.)</p> |

## Attaching a Class to a Bundle

| Command  | Purpose   |
|--|---|
| <pre>(config-atm-bundle)# class-bundle vc-class-name</pre> | <p>Configures a bundle with the bundle-level commands contained in the specified VC class.</p> <p><b>Note</b> Parameters set through bundle-level commands contained in the VC class are applied to the bundle and all of its VC members. Bundle-level parameters applied through commands configured directly on the bundle supersede those applied through a VC class. Some bundle-level parameters applied through a VC class or directly to the bundle can be superseded by commands that you directly apply to individual VCs in bundle-vc configuration mode.</p> |

## Committing a VC to a Bundle

| Command  | Purpose  |
|--|--|
| <pre>Device(config-atm-bundle)# pvc-bundle pvc-name [vpi/] [vci]</pre> | <p>Adds the specified VC to the bundle and enters bundle-vc configuration mode in order to configure the specified VC bundle member.</p> |

## Applying Parameters to Individual VCs

### Configuring a VC Bundle Member Directly

| Command  | Purpose   |
|--|---|
| Device(config-if-atm-member) # <b>ubr</b> <i>output-pcr</i><br>[ <i>input-pcr</i> ]  | Configures the VC for unspecified bit rate (UBR) QoS and specifies the output peak cell rate (PCR) for it.  |
| Device(config-if-atm-member) # <b>ubr+</b> <i>output-pcr</i><br><i>output-mcr</i> [ <i>input-pcr</i> ] [ <i>input-mcr</i> ]                                | Configures the VC for UBR QoS and specifies the output PCR and output minimum guaranteed cell rate for it.  |
| Device(config-if-atm-member) # <b>vbr-nrt</b><br><i>output-pcr output-scr output-mbs</i> [ <i>input-pcr</i> ]<br>[ <i>input-scr</i> ] [ <i>input-mbs</i> ] | Configures the VC for variable bit rate nonreal-time (VBR-nrt) QoS and specifies the output PCR, output sustainable cell rate, and output maximum burst cell size for it. |
| Device(config-if-atm-member) # <b>precedence</b><br>[ <b>other</b>   <i>range</i> ]  | Configures the precedence levels for the VC.  |
| Device(config-if-atm-member) # <b>bump</b> { <b>implicit</b><br>  <b>explicit</b> <i>precedence-level</i>   <b>traffic</b> }                               | Configures the bumping rules for the VC.  |
| Device(config-if-atm-member) # <b>protect</b> { <b>group</b><br>  <b>vc</b> }  | Configures the VC to belong to the protected group of the bundle or to be an individually protected VC bundle member.   |

## Configuring VC Class Parameters to Apply to a VC Bundle Member

| Command   | Purpose  |
|---|--|
| Device(config-vc-class)# <b>bump</b> {implicit   explicit <i>precedence-level</i>   traffic}                          | <p>Specifies the bumping rules for the VC member to which the class is applied. These rules determine to which VC in the bundle traffic is directed when the carrier VC bundle member goes down.</p> <p><b>Note</b> You can also add the following commands to a VC class to be used to configure a VC bundle member: <b>ubr</b>, <b>ubr+</b>, and <b>vbr-nrt</b>. When a VC is a member of a VC bundle, the following commands cannot be used in vc-class mode to configure the VC: <b>encapsulation</b>, <b>protocol</b>, <b>inarp</b>, and <b>broadcast</b>. These commands are useful only at the bundle level, not the bundle member level. Configuration for an individual VC overrides the collective configuration applied to all VC bundle members through application of a VC class to the bundle.</p> |
| Device(config-vc-class)# <b>precedence</b> <i>precedence min-threshold max-threshold mark-probability-denominator</i> | Defines precedence levels for the VC member to which the class is applied.   |
| Device(config-vc-class)# <b>protect</b> {group   vc}  | Configures the VC as a member of the protected group of the bundle or as an individually protected VC.   |

## Applying a VC Class to a Discrete VC Bundle Member

| Command   | Purpose                                   |
|---|---|
| Device(config-if-atm-member)# <b>class-vc</b> <i>vc-class -name</i> | Assigns a VC class to a VC bundle member. |

## Configuring a VC Not to Accept Bumped Traffic

| Command  | Purpose  |
|--|--|
| Router(config-if-atm-member)# <b>no bump traffic</b> | Configures the VC not to accept any bumped traffic that would otherwise be redirected to it. |

## Monitoring and Maintaining VC Bundles and Their VC Members

| Command  | Purpose  |
|--|--|
| Device# <b>show atm bundle</b> <i>bundle-name</i>  | Displays the bundle attributes assigned to each bundle VC member and the current working status of the VC members. |
| Device# <b>show atm bundle</b> <i>bundle-name</i> <b>statistics</b><br>[ <b>detail</b> ] | Displays statistics or detailed statistics on the specified bundle.  |
| Device# <b>show atm map</b>  | Displays a list of all configured ATM static maps to remote hosts on an ATM network and on ATM bundle maps.        |
| Device# <b>debug atm bundle errors</b>   | Displays information on bundle errors.   |
| Device# <b>debug atm bundle events</b>   | Displays a record of bundle events.  |

## Per-VC WFQ and CBWFQ Configuration Task List

To configure IP to ATM CoS for per-VC WFQ and CBWFQ, perform the tasks described in the following sections.

The IP to ATM CoS feature requires ATM PVC management.

### Configuring Class-Based Weighted Fair Queueing

Before configuring CBWFQ for a VC, you must perform the following tasks using standard CBWFQ commands:

- Create one or more classes to be used to classify traffic sent across the VC
- Define a policy map containing the classes to be used as the service policy



#### Note

You can configure class policies for as many classes as are defined on the router, up to the maximum of 64. However, the total amount of bandwidth allocated for all classes included in a policy map to be attached to a VC must not exceed 75 percent of the available bandwidth of the VC. The remaining 25 percent of available bandwidth is used for encapsulation, such as the ATM cell overhead (also referred to as ATM cell tax), routing and best-effort traffic, and other functions that assume overhead. For more information on bandwidth allocation, see the "Congestion Management Overview" module.

Because CBWFQ gives you minimum bandwidth guarantee, you can only apply CBWFQ to VCs having these classes of service: available bit rate (ABR) and variable bit rate (VBR). You cannot apply per-VC WFQ



and CBWFQ to UBR and unspecified bit rate plus (UBR+) VCs because both of these service classes are best-effort classes that do not guarantee minimum bandwidth. When CBWFQ is enabled for a VC, all classes configured as part of the service policy are installed in the fair queuing system.

In addition to configuring CBWFQ at the VC level, the IP to ATM CoS feature allows you to configure flow-based WFQ at the VC level. Because flow-based WFQ gives you best-effort class of service--that is, it does not guarantee minimum bandwidth--you can configure per-VC WFQ for all types of CoS VCs: ABR, VBR, UBR, and UBR+.

Per-VC WFQ uses the class-default class. Therefore, to configure per-VC WFQ, you must first create a policy map and configure the class-default class. (You need not create the class-default class, which is predefined, but you must configure it.) For per-VC WFQ, the class-default class must be configured with the **fair-queue** policy-map class configuration command.

In addition to configuring the **fair-queue** policy-map class configuration command, you can configure the default class with either the **queue-limit** command or the **random-detect** command, but not both. Moreover, if you want the default class to use flow-based WFQ, you cannot configure the default class with the **bandwidth** policy-map class configuration command--to do so would disqualify the default class as flow-based WFQ, and therefore limit application of the service policy containing the class to ABR and VBR VCs.

## Attaching a Service Policy and Enabling CBWFQ for a VC

### Attaching a Policy Map to a Standalone VC and Enabling CBWFQ

| Command  | Purpose  |
|--|--|
| Router (config-if-atm-vc) # <b>service-policy output</b> <i>policy-map</i> | Enables CBWFQ and attaches the specified service policy map to the VC being created or modified. |

### Attaching a Policy Map to an Individual VC and Enabling CBWFQ

| Command  | Purpose  |
|--|--|
| Router (config-if-atm-member) # <b>service-policy output</b> <i>policy-map</i> | Enables CBWFQ and attaches the specified service policy map to the VC being created or modified. |



#### Note

The **service-policy output** and **random-detect-group** commands are mutually exclusive; you cannot apply a WRED group to a VC for which you have enabled CBWFQ through application of a service policy. Moreover, before you can configure one command, you must disable the other if it is configured.

## Configuring a VC to Use Flow-Based WFQ

### SUMMARY STEPS

1. Router(config)# **policy-map** *policy-map*
2. Router(config-pmap)# **class class-default** *default-class-name*
3. Router(config-pmap-c)# **fair-queue** *number-of-dynamic-queues*
4. Do one of the following:
  - Router(config-pmap-c)# **queue-limit** *number-of-packets*
  - Router(config-pmap-c)# **random-detect**

### DETAILED STEPS

|               | Command or Action  | Purpose  |
|---------------|--|--|
| <b>Step 1</b> | Router(config)# <b>policy-map</b> <i>policy-map</i>  | Specifies the name of the policy map to be created or modified.  |
| <b>Step 2</b> | Router(config-pmap)# <b>class class-default</b> <i>default-class-name</i>  | Specifies the default class so that you can configure or modify its policy.<br><b>Note</b> You can include other classes in the same policy map as the one that contains the flow-based WFQ class. Packets not otherwise matched are selected by the default class-default class match criteria.   |
| <b>Step 3</b> | Router(config-pmap-c)# <b>fair-queue</b> <i>number-of-dynamic-queues</i>   | Specifies the number of dynamic queues to be reserved for use by flow-based WFQ running on the default class.<br><b>Note</b> By default--that is, even if you do not configure the class-default class with the <b>fair-queue</b> policy-map class configuration command and you do not configure it with the <b>bandwidth</b> policy-map class configuration command--the default class is defined as flow-based WFQ. |
| <b>Step 4</b> | Do one of the following: <ul style="list-style-type: none"> <li>• Router(config-pmap-c)# <b>queue-limit</b> <i>number-of-packets</i></li> <li>• Router(config-pmap-c)# <b>random-detect</b></li> </ul> | Specifies the maximum number of packets that can be queued for the class.<br>Enables WRED. The class policy will drop packets using WRED instead of tail drop.   |

## Attaching a Policy Map to a Standalone VC and Enabling WFQ

| Command  | Purpose  |
|--|--|
| Router(config-if-atm-vc) # <b>service-policy output</b><br><i>policy-map</i> | Enables WFQ for the VC by attaching the specified policy map containing the class-default class to the VC being created or modified. |

## Attaching a Policy Map to an Individual VC and Enabling WFQ

| Command   | Purpose  |
|---|--|
| Router(config-if-atm-member) # <b>service-policy output</b> <i>policy-map</i> | Enables WFQ for the VC bundle member by attaching the specified policy map containing the class-default class to the VC bundle member. |

## Monitoring per-VC WFQ and CBWFQ

| Command   | Purpose   |
|---|---|
| Router# <b>show queue</b> <i>interface-name</i><br><i>interface-number</i> [ <b>vc</b> [ <i>vpi/ vci</i> ]] | Displays the contents of packets inside a queue for a particular interface or VC. |
| Router# <b>show queueing interface</b><br><i>interface-number</i> [ <b>vc</b> [ <i>vpi/ vci</i> ]]          | Displays the queueing statistics of a specific VC on an interface.                |

## Enabling Logging of Error Messages to the Console

| Command  | Purpose  |
|--|--|
| Router(config) # <b>logging console</b> <i>level</i> | Limits messages logged to the console based on severity. |

# IP to ATM CoS Configuration Examples

## Example Single ATM VC with WRED Group and IP Precedence

The following example creates a PVC on an ATM interface and applies the WRED parameter group called sanjose to that PVC. Next, the IP Precedence values are configured for the WRED parameter group sanjose.

```
interface ATM1/1/0.46 multipoint
 ip address 200.126.186.2 255.255.255.0
 no ip mroute-cache
 shutdown
 pvc cisco 46
 encapsulation aal5nlpid
 random-detect attach sanjose
 !
 random-detect-group sanjose
 precedence 0 200 1000 10
 precedence 1 300 1000 10
 precedence 2 400 1000 10
 precedence 3 500 1000 10
 precedence 4 600 1000 10
 precedence 5 700 1000 10
 precedence 6 800 1000 10
 precedence 7 900 1000 10
```

## Example VC Bundle Configuration Using a VC Class

This example configures VC bundle management on a router that uses Intermediate System-to-Intermediate System (IS-IS) as its IP routing protocol.

### Bundle-Class Class

At the outset, this configuration defines a VC class called bundle-class that includes commands that set VC parameters. When the class bundle-class is applied at the bundle level, these parameters are applied to all VCs that belong to the bundle. Note that any commands applied directly to an individual VC of a bundle in bundle-vc mode take precedence over commands applied globally at the bundle level. Taking into account hierarchy precedence rules, VCs belonging to any bundle to which the class bundle-class is applied will be characterized by these parameters: aal5snap encapsulation, broadcast on, use of Inverse Address Resolution Protocol (ARP) to resolve IP addresses, and operation, administration, and maintenance (OAM) enabled.

```
router isis
 net 49.0000.0000.0000.1111.00
 vc-class atm bundle-class
 encapsulation aal5snap
 broadcast
 protocol ip inarp
 oam-bundle manage 3
 oam retry 4 3 10
```

The following sections of the configuration define VC classes that contain commands specifying parameters that can be applied to individual VCs in a bundle by assigning the class to that VC.

## Control-Class Class

When the class called control-class is applied to a VC, the VC carries traffic whose IP Precedence level is 7. When the VC to which this class is assigned goes down, it takes the bundle down with it because this class makes the VC a protected one. The QoS type of a VC using this class is vbr-nrt.

```
vc-class atm control-class
  precedence 7
  protect vc
  vbr-nrt 10000 5000 32
```

## Premium-Class Class

When the class called premium-class is applied to a VC, the VC carries traffic whose IP Precedence levels are 6 and 5. The VC does not allow other traffic to be bumped onto it. When the VC to which this class is applied goes down, its bumped traffic will be redirected to a VC whose IP Precedence level is 7. This class makes a VC a member of the protected group of the bundle. When all members of a protected group go down, the bundle goes down. The QoS type of a VC using this class is vbr-nrt.

```
vc-class atm premium-class
  precedence 6-5
  no bump traffic
  protect group
  bump explicitly 7
  vbr-nrt 20000 10000 32
```

## Priority-Class Class

When the class called priority-class is applied to a VC, the VC is configured to carry traffic with IP Precedence in the 4-2 range. The VC uses the implicit bumping rule, it allows traffic to be bumped, and it belongs to the protected group of the bundle. The QoS type of a VC using this class isubr+.

```
vc-class atm priority-class
  precedence 4-2
  protect group
  ubr+ 10000 3000
```

## Basic-Class Class

When the class called basic-class is applied to a VC, the VC is configured through the **precedence other** command to carry traffic with IP Precedence levels not specified in the profile. The VC using this class belongs to the protected group of the bundle. The QoS type of a VC using this class isubr.

```
vc-class atm basic-class
  precedence other
  protect group
  ubr 10000
```

The following sets of commands configure three bundles that the router subinterface uses to connect to three of its neighbors. These bundles are called new-york, san-francisco, and los-angeles. Bundle new-york has four VC members, bundle san-francisco has four VC members, and bundle los-angeles has three VC members.

## new-york Bundle

The first part of this example specifies the IP address of the subinterface, the router protocol--the router uses IS-IS as an IP routing protocol--and it creates the first bundle called new-york and enters bundle configuration mode:

```
interface atm 1/0.1 multipoint
 ip address 10.0.0.1 255.255.255.0
 ip router isis
 bundle new-york
```

From within bundle configuration mode, the next portion of the configuration uses two protocol commands to enable IP and Open Systems Interconnect (OSI) traffic flows in the bundle. The OSI routing packets will use the highest precedence VC in the bundle. The OSI data packets, if any, will use the lowest precedence VC in the bundle. If configured, other protocols, such as IPX or AppleTalk, will always use the lowest precedence VC in the bundle.

As the indentation levels of the preceding and following commands suggest, subordinate to bundle new-york is a command that configures its protocol and a command that applies the class called bundle-class to it.

```
    protocol ip 1.1.1.2 broadcast
    protocol clns 49.0000.0000.2222.00 broadcast
    class-bundle bundle-class
```

The class called bundle-class, which is applied to the bundle new-york, includes a **protocol ip inarp** command. According to inheritance rules, **protocol ip**, configured at the bundle level, takes precedence over **protocol ip inarp** specified in the class bundle-class.

The next set of commands beginning with **pvc-bundle ny-control 207**, which are further subordinate, add four VCs (called ny-control, ny-premium, ny-priority, and ny-basic) to the bundle new-york. A particular class--that is, one of the classes predefined in this configuration example--is applied to each VC to configure it with parameters specified by commands included in the class.

As is the case for this configuration, to configure individual VCs belonging to a bundle, the router must be in bundle mode for the mother bundle. For each VC belonging to the bundle, the subordinate mode is pvc-mode for the specific VC.

The following commands configure the individual VCs for the bundle new-york:

```
pvc-bundle ny-control 207
 class-vc control-class
pvc-bundle ny-premium 206
 class-vc premium-class
pvc-bundle ny-priority 204
 class-vc priority-class
pvc-bundle ny-basic 201
 class-vc basic-class
```

## san-francisco Bundle

The following set of commands create and configure a bundle called san-francisco. At the bundle configuration level, the configuration commands included in the class bundle-class are ascribed to the bundle san-francisco and to the individual VCs that belong to the bundle. Then, the **pvc-bundle** command is executed for each individual VC to add it to the bundle. After a VC is added and bundle-vc configuration mode is entered, a particular, preconfigured class is assigned to the VC. The configuration commands comprising that class are used to configure the VC. Rules of hierarchy apply at this point. Command parameters contained in the applied

class are superseded by the same parameters applied at the bundle configuration level, which are superseded by the same parameters applied directly to a VC.

```
bundle san-francisco
  protocol clns 49.0000.0000.0000.333.00 broadcast
  inarp 1
  class-bundle bundle-class
  pvc-bundle sf-control 307
    class-vc control-class
  pvc-bundle sf-premium 306
    class-vc premium-class
  pvc-bundle sf-priority 304
    class-vc priority-class
  pvc-bundle sf-basic 301
    class-vc basic-class
```

## Los-angeles Bundle

The following set of commands create and configure a bundle called los-angeles. At the bundle configuration level, the configuration commands included in the class bundle-class are ascribed to the bundle los-angeles and to the individual VCs that belong to the bundle. Then, the **pvc-bundle** command is executed for each individual VC to add it to the bundle. After a VC is added and bundle-vc configuration mode is entered, precedence is set for the VC and the VC is either configured as a member of a protected group (protect group) or as an individually protected VC. A particular class is then assigned to each VC to further characterize it. Rules of hierarchy apply. Parameters of commands applied directly and discretely to a VC take precedence over the same parameters applied within a class to the VC at the bundle-vc configuration level, which take precedence over the same parameters applied to the entire bundle at the bundle configuration level.

```
bundle los-angeles
  protocol ip 1.1.1.4 broadcast
  protocol clns 49.0000.0000.4444.00 broadcast
  inarp 1
  class-bundle bundle-class
  pvc-bundle la-high 407
    precedence 7-5
    protect vc
    class-vc premium-class
  pvc-bundle la-mid 404
    precedence 4-2
    protect group
    class-vc priority-class
  pvc-bundle la-low 401
    precedence other
    protect group
    class-vc basic-class
```

## Example Per-VC WFQ and CBWFQ on a Standalone VC

The following example creates two class maps and defines their match criteria. For the first map class, called class1, the numbered access control list (ACL) 101 is used as the match criterion. For the second map class called class2, the numbered ACL 102 is used as the match criterion.

Next, the example includes these classes in a policy map called policy1. For class1, the policy includes a minimum bandwidth allocation request of 500 kbps and maximum packet count limit of 30 for the queue reserved for the class. For class2, the policy specifies only the minimum bandwidth allocation request of 1000 kbps, so the default queue limit of 64 packets is assumed. Note that the sum of the bandwidth requests for the two classes comprising policy1 is 75 percent of the total amount of bandwidth (2000 kbps) for the PVC called cisco to which the policy map is attached.

The example attaches the policy map called policy1 to the PVC called cisco. Once the policy map policy1 is attached to PVC cisco, its classes constitute the CBWFQ service policy for that PVC. Packets sent on this PVC will be checked for matching criteria against ACLs 101 and 102 and classified accordingly.

Because the **class-default** command is not explicitly configured for this policy map, all traffic that does not meet the match criteria of the two classes comprising the service policy is handled by the predefined class-default class, which provides best-effort flow-based WFQ.

```
class-map class1
  match access-group 101
class-map class2
  match access-group 102
policy-map policy1
  class class1
    bandwidth 500
    queue-limit 30
  class class2
    bandwidth 1000
interface ATM1/1/0.46 multipoint
ip address 200.126.186.2 255.255.255.0
pvc cisco 46
  vbr-nrt 2000 2000
  encaps aal5snap
  service policy output policy1
```

## Example Per-VC WFQ and CBWFQ on Bundle-Member VCs

The following example shows a PVC bundle called san-francisco with members for which per-VC WFQ and CBWFQ are enabled and service policies configured. The example assumes that the classes included in the following policy maps have been defined and that the policy maps have been created: policy1, policy2, and policy4. For each PVC, the IP to ATM CoS **pvc-bundle** command is used to specify the PVC to which the specified policy map is to be attached.

Note that PVC 0/34 and 0/31 have the same policy map attached to them, policy2. Although you can assign the same policy map to multiple VCs, each VC can have only one policy map attached at an output PVC.

```
bundle san-francisco
  protocol ip 1.0.2.20 broadcast
  encapsulation aal5snap
  pvc-bundle 0/35
    service policy output policy1
    vbr-nrt 5000 3000 500
    precedence 4-7
  pvc-bundle 0/34
    service policy output policy2
    vbr-nrt 5000 3000 500
    precedence 2-3
  pvc-bundle 0/33
    vbr-nrt 4000 3000 500
    precedence 2-3
    service policy output policy4
  pvc-bundle 0/31
    service policy output policy2
```





# IP to ATM Class of Service Mapping for SVC Bundles

## Feature History

| Release   | Modification                 |
|-----------|------------------------------|
| 12.2(4) T | This feature was introduced. |

This feature module describes the IP to ATM Class of Service Mapping for SVC Bundles feature for Cisco IOS Release 12.2(4)T and includes the following sections:

- [Finding Feature Information, page 27](#)
- [Feature Overview, page 28](#)
- [Supported Platforms, page 29](#)
- [Supported Standards MIBs and RFCs, page 29](#)
- [Prerequisites, page 30](#)
- [Configuration Tasks, page 30](#)
- [Monitoring IP to ATM Class of Service Mapping for SVC Bundles, page 32](#)
- [Configuration Examples, page 33](#)

## Finding Feature Information

Your software release may not support all the features documented in this module. For the latest caveats and feature information, see [Bug Search Tool](#) and the release notes for your platform and software release. To find information about the features documented in this module, and to see a list of the releases in which each feature is supported, see the feature information table at the end of this module.

Use Cisco Feature Navigator to find information about platform support and Cisco software image support. To access Cisco Feature Navigator, go to [www.cisco.com/go/cfn](http://www.cisco.com/go/cfn). An account on Cisco.com is not required.

## Feature Overview

The IP to ATM Class of Service Mapping for SVC Bundles feature supports multiple switched virtual circuits (SVCs) to the same NSAP destination for different types of service (ToS). This feature is an extension of the feature described in the "Configuring IP to ATM Class of Service" module. The original feature was limited to permanent virtual circuits (PVCs) only. This feature is an extension because it applies to SVCs.

The PVC bundle feature requires that the user configure PVCs for different IP ToS. The PVCs have to be set up throughout the ATM network between endpoints. The IP to ATM Class of Service Mapping for SVC Bundles feature needs configuration only at the endpoints. The user does not configure SVCs; the software sets up SVCs in a bundle between endpoints. When the router receives the first IP packet for the destination that is configured in the SVC bundle, that event triggers the creation of the SVC.

A default SVC is used for non-IP traffic, IP traffic with no precedence, and IP traffic with the precedence bit set but for which no SVC exists. SVC setup for the specific IP precedence traffic is triggered when the first IP packet with that precedence bit set is received.

## Benefits

### Multiple SVCs with Different QoS Parameters

Users can have multiple SVCs, each with different QoS parameters, between SVC endpoints. This allows the customer to easily offer differentiated services between SVC nodes.

### Reduced Configuration

SVC bundle configuration requires less configuration than a PVC configuration. The PVC bundle feature needs the configuration of PVCs in bundles throughout the ATM network. However, an SVC bundle needs configuration only at the endpoints and uses the User-Network Interface (UNI) to set up SVCs in the bundle between endpoints.

## Restrictions

- Both router platforms require enhanced ATM port adapters.

## Related Features and Technologies

The SVC bundle feature is similar to the IP to ATM Class of Service feature, which is documented in the "Configuring IP to ATM Class of Service" module.

## Related Documents

For related information on this feature, refer to the following documents:

- "Configuring IP to ATM Class of Service" module
- "IP to ATM Class of Service Overview" module

- *Cisco IOS Quality of Service Solutions Command Reference.*
- "Configuring ATM" module
- *Cisco IOS Wide-Area Networking Command Reference*

## Supported Platforms

- Cisco 7200 series with enhanced ATM port adapters

### Platform Support Through Feature Navigator

Cisco IOS software is packaged in feature sets that support specific platforms. To get updated information regarding platform support for this feature, access Feature Navigator. Feature Navigator dynamically updates the list of supported platforms as new platform support is added for the feature.

Feature Navigator is a web-based tool that enables you to quickly determine which Cisco IOS software images support a specific set of features and which features are supported in a specific Cisco IOS image.

To access Feature Navigator, you must have an account on Cisco.com. If you have forgotten or lost your account information, send a blank e-mail to [cco-locksmith@cisco.com](mailto:cco-locksmith@cisco.com). An automatic check will verify that your e-mail address is registered with Cisco.com. If the check is successful, account details with a new random password will be e-mailed to you. Qualified users can establish an account on Cisco.com by following the directions at <http://www.cisco.com/register>.

Feature Navigator is updated when major Cisco IOS software releases and technology releases occur. As of May 2001, Feature Navigator supports M, T, E, S, and ST releases. You can access Feature Navigator at the following URL:

<http://www.cisco.com/go/fn>

## Supported Standards MIBs and RFCs

### Standards

No new or modified standards are supported by this feature.

### MIBs

No new or modified MIBs are supported by this feature.

To obtain lists of supported MIBs by platform and Cisco IOS release, and to download MIB modules, go to the Cisco MIB website on Cisco.com at the following URL:

<http://www.cisco.com/public/sw-center/netmgmt/cmtk/mibs.shtml>

### RFCs

None

## Prerequisites

Before configuring the IP to ATM Class of Service for SVC Bundles feature, you should read and understand the concepts in the following modules:

- "Configuring ATM" module
- "Configuring IP to ATM Class of Service" module
- "IP to ATM Class of Service Overview" module

## Configuration Tasks

The following sections describe configuration tasks for the IP to ATM Class of Service Mapping for SVC Bundles feature. Each task in the list is identified as either optional or required.

Note that the bundle members must be configured either directly, by bundle-level parameters, or by class. The bundle configuration should be the same on both ends (the end where the SVC is initiated and the end where it is terminated).

## Creating an SVC Bundle

| Command  | Purpose   |
|--|---|
| <pre>Router(config-if)# <b>bundle svc</b> <i>bundle-name</i> <b>nsap</b> <i>destination-nsap-address</i></pre> | Creates or modifies an SVC bundle. The name must be the same on both sides of the VC. |

## Configuring Bundle-Level Parameters

| Command   | Purpose  |
|---|--|
| Router(config-if-atm-svc-bundle)# <b>protocol ip</b><br><i>protocol-address broadcast</i> | Configures the destination network address of an SVC bundle.   |
| Router(config-if-atm-svc-bundle)#<br><b>encapsulation aal5 snap mux ip</b>                | Sets the encapsulation method used by the interface. By default, <b>encapsulation aal5 snap</b> is enabled.  |
| Router(config-if-atm-svc-bundle)#<br><b>class-bundle</b> <i>vc-class-name</i>             | (Optional) Configures a bundle with the bundle-level commands contained in the specified VC class.   |
| Router(config-if-atm-svc-bundle)#<br><b>oam-bundle manage</b> [ <i>frequency</i> ]        | (Optional) Enables end-to-end F5 operation, administration, and maintenance (OAM) loopback cell generation and OAM management for all VC members of a bundle or a VC class that can be applied to a VC bundle. |

## Attaching a Class to a Bundle

| Command   | Purpose  |
|---|--|
| Router(config-if-atm-svc-bundle)#<br><b>class-bundle</b> <i>vc-class-name</i> | (Optional) Configures a bundle with the bundle-level commands contained in the specified VC class. |

## Configuring an SVC Bundle Member Directly

### SUMMARY STEPS

1. Router(config-if-atm-svc-bundle)# **svc-bundle** *svc-handle*
2. Router(config-if-atm-svc-member)# **ubr** *output-pcr input-pcr*
3. Router(config-if-atm-svc-member)# **ubr+** *output-pcr output-mcr input-pcr* [*input-mcr*]
4. Router(config-if-atm-svc-member)# **vbr-rt** *peak-rate average-rate burst*
5. Router(config-if-atm-svc-member)# **precedence other** | *range*
6. Router(config-if-atm-svc-member)# **bump implicit** | **explicit** *precedence-level traffic*
7. Router(config-if-atm-svc-member)# **idle-timeout** *seconds minimum-rate*
8. Router(config-if-atm-svc-member)# **class-vc** *vc-class-name*

## DETAILED STEPS

|               | Command or Action  | Purpose  |
|---------------|--|--|
| <b>Step 1</b> | Router(config-if-atm-svc-bundle)# <b>svc-bundle</b><br><i>svc-handle</i>   | Creates or modifies a member of an SVC bundle.<br><br><b>Note</b> Each SVC bundle can have a maximum of eight members. The number of members and the precedence values attached to them should be the same on both ends of the SVC (that is, where the SVC is initiated and where it is terminated). |
| <b>Step 2</b> | Router(config-if-atm-svc-member)# <b>ubr</b> <i>output-pcr</i><br><i>input-pcr</i>   | Configures the VC for unspecified bit rate (UBR) QoS and specifies the output peak cell rate (PCR) for it.   |
| <b>Step 3</b> | Router(config-if-atm-svc-member)# <b>ubr+</b> <i>output-pcr</i><br><i>output-mcr</i> <i>input-pcr</i> [ <i>input-mcr</i> ] | Configures the VC for UBR QoS and specifies the output PCR and output minimum guaranteed cell rate for it.   |
| <b>Step 4</b> | Router(config-if-atm-svc-member)# <b>vbr-rt</b> <i>peak-rate</i><br><i>average-rate</i> <i>burst</i>                       | Configures the real-time variable bit rate (VBR).  |
| <b>Step 5</b> | Router(config-if-atm-svc-member)# <b>precedence</b><br><b>other</b>   <i>range</i>   | Configures the precedence levels for the VC.   |
| <b>Step 6</b> | Router(config-if-atm-svc-member)# <b>bump implicit</b><br>  <b>explicit</b> <i>precedence-level</i> <b>traffic</b>         | Configures the bumping rules for the VC.   |
| <b>Step 7</b> | Router(config-if-atm-svc-member)# <b>idle-timeout</b><br><i>seconds</i> <i>minimum-rate</i>                                | Configure the idle timeout parameter for tearing down an ATM SVC.  |
| <b>Step 8</b> | Router(config-if-atm-svc-member)# <b>class-vc</b><br><i>vc-class-name</i>  | Assigns a VC class to a VC bundle member.  |

## Monitoring IP to ATM Class of Service Mapping for SVC Bundles

| Command  | Purpose  |
|--|--|
| Router# <b>debug atm bundle error</b>                                      | Displays debug messages for SVC bundle errors.   |
| Router# <b>debug atm bundle events</b>                                     | Displays SVC bundle events.  |
| Router# <b>show atm bundle svc</b> <i>bundle-name</i>                      | Displays the bundle attributes assigned to each bundle VC member and the current working status of the VC members. |
| Router# <b>show atm bundle svc</b> <i>bundle-name</i><br><b>statistics</b> | Displays the statistics of an SVC bundle.  |

# Configuration Examples

## Example IP to ATM Class of Service Mapping in Bundle Mode

In this example, the bundle parameters are configured in bundle mode. Initially, the end station ID (ESI) address and an Integrated Local Management Interface (ILMI) PVC are configured.

The PVC helps in getting the prefix from the switch (for example, an LS 1010). The combined address is the NSAP address.

You also need to know the other NSAP address to configure the SVC bundle. The eight VC classes are configured with precedences and traffic parameters. The classes must be configured before you attach them to the specific members. The **vc-class** commands could also be configured in the bundle-member configuration. The configuration of the members must be the same at both ends (that is, where the bundle is initiated and where it is terminated).

```

vc-class atm seven
  vbr-nrt 10000 5000 32
  precedence 7
!
vc-class atm six
  ubr 6000
  precedence 6
!
vc-class atm five
  ubr 5000
  precedence 5
  bump explicit 7
!
vc-class atm four
  ubr 4000
  precedence 4
!
vc-class atm three
  ubr 3000
  precedence 3
!
vc-class atm two
  ubr 2000
  precedence 2
!
vc-class atm one
  ubr 1000
  precedence 1
!
vc-class atm zero
  ubr 500
  precedence other
!
no ip address
no ip mroute-cache
no atm ilmi-keepalive
atm voice aal2 aggregate-svc upspeed-number 0
pvc qsaal 0/5 qsaal
!
pvc ilmi 0/16 ilmi
!
bundle-enable
!
interface ATM1/0.1 multipoint
ip address 170.100.9.2 255.255.255.0
atm esi-address 11111111111.11
bundle svc test nsap 47.0091810000000003E3924F01.999999999999.99

```

```

protocol ip 170.100.9.1
broadcast
oam retry 4 3 10
encapsulation aal5snap
oam-bundle manage
svc-bundle seven
  class-vc seven
svc-bundle six
  class-vc six
svc-bundle five
  class-vc five
svc-bundle four
  class-vc four
svc-bundle three
  class-vc three
svc-bundle two
  class-vc two
svc-bundle one
  class-vc one
svc-bundle zero
  class-vc zero
!
```

## Example IP to ATM Class of Service Mapping Using the class-bundle Command

In this example, the bundle parameters are added to the bundle by using the **class-bundle** command. The class attached is named "sanjose".

```

vc-class atm sanjose          !Here we are attaching this vc-class to the whole bundle
  broadcast
  oam retry 4 3 10
  encapsulation aal5snap
  oam-bundle manage 3
!
vc-class atm med
 ubr 10000
  precedence 4-5
!
vc-class atm high
vbr-nrt 10000 5000 32
 precedence 6-7
!
vc-class atm low
ubr+ 100000 5000
 precedence 0-3
interface ATM1/0
ip address 3.3.3.1 255.255.255.0
atm idle-timeout 5
atm esi-address 665544332211.22
no atm ilmi-keepalive
atm voice aal2 aggregate-svc upspeed-number 0
pvc 0/5 qsaal
!
pvc 0/16 ilmi
!
pvc 0/100
!
bundle svc svc-test nsap 47.00918100000000003E3924F01.998877665533.88
  class-bundle bundle-test
  protocol ip 3.3.3.2
  svc-bundle high
    class-vc high
  svc-bundle med
    class-vc med
  svc-bundle low
    class-vc low
!
```





# ATMPVC Bundle Enhancement MPLS EXP-Based PVC Selection

## Feature History

| Release  | Modification                 |
|----------|------------------------------|
| 12.2(8)T | This feature was introduced. |

This module describes the ATM PVC Bundle Enhancement MPLS EXP-Based PVC Selection feature in Cisco IOS Release 12.2(8)T. It includes the following sections:

- [Finding Feature Information, page 35](#)
- [Feature Overview, page 36](#)
- [Supported Platforms, page 38](#)
- [Supported Standards MIBs and RFCs, page 39](#)
- [Configuration Tasks, page 39](#)
- [Configuration Examples, page 43](#)
- [Command Reference, page 46](#)

## Finding Feature Information

Your software release may not support all the features documented in this module. For the latest caveats and feature information, see [Bug Search Tool](#) and the release notes for your platform and software release. To find information about the features documented in this module, and to see a list of the releases in which each feature is supported, see the feature information table at the end of this module.

Use Cisco Feature Navigator to find information about platform support and Cisco software image support. To access Cisco Feature Navigator, go to [www.cisco.com/go/cfn](http://www.cisco.com/go/cfn). An account on Cisco.com is not required.

## Feature Overview

The ATM PVC Bundle Enhancement MPLS EXP-Based PVC Selection feature is an extension to the IP to ATM Class of Service feature suite. The IP to ATM Class of Service feature suite, using virtual circuit (VC) support and bundle management, maps quality of service (QoS) characteristics between IP and ATM. It provides customers who have multiple VCs (with varying qualities of service to the same destination) the ability to build a QoS differentiated network.

The IP to ATM Class of Service feature suite allowed customers to use IP precedence level as the selection criteria for packet forwarding. This new feature now gives customers the option of using the Multiprotocol Label Switching (MPLS) experimental (EXP) level as an additional selection criteria for packet forwarding.



**Note**

If a selection criteria for packet forwarding is not selected (that is, if the packet is unlabeled), this new feature uses the IP precedence level as the default selection criteria.

## VC Bundle Support and Bundle Management

ATM VC bundle management allows you to configure multiple VCs that have different QoS characteristics between any pair of ATM-connected routers. As shown in the figure below, these VCs are grouped in a bundle and are referred to as bundle members.

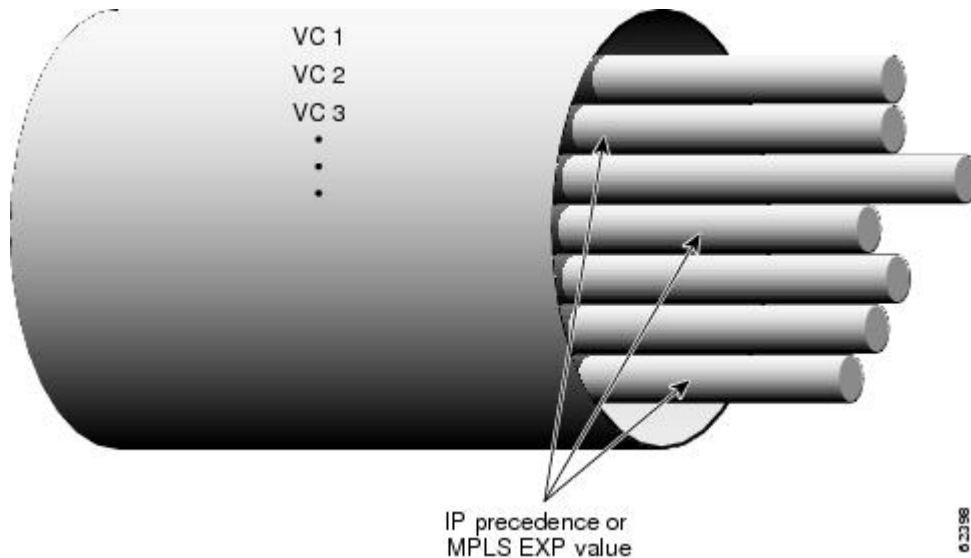
**Figure 6: ATM VC Bundle**



ATM VC bundle management allows you to define an ATM VC bundle and add VCs to it. Each VC of a bundle has its own ATM traffic class and ATM traffic parameters. You can apply attributes and characteristics to discrete VC bundle members, or you can apply them collectively at the bundle level.

Using VC bundles, you can create differentiated service by flexibly distributing MPLS EXP levels over the different VC bundle members. You can map a single MPLS EXP level, or a range of these levels, to each

discrete VC in the bundle, thereby enabling individual VCs in the bundle to carry packets marked with different MPLS EXP levels. You can use Weighted Random Early Detection (WRED) or distributed WRED (dWRED) to further differentiate service across traffic that has different MPLS EXP levels.

To determine which VC in the bundle to use to forward a packet to its destination, the ATM VC bundle management software matches MPLS EXP levels between packets and VCs (see the figure below). IP traffic is sent to the next hop address for the bundle because all VCs in a bundle share the same destination, but the VC used to carry a packet depends on the value set for that packet in the MPLS EXP level of the type of service (ToS) byte of its header. The ATM VC bundle management software matches the MPLS EXP level of the packet to the MPLS EXP levels assigned to a VC, sending the packet out on the appropriate VC. Moreover, the ATM VC bundle management software allows you to configure how traffic will be redirected when the VC to which the packet was initially directed goes down. The figure below illustrates how the ATM VC bundle management software determines which permanent virtual circuit (PVC) bundle member to use to carry a packet and how WRED (or dWRED) is used to differentiate traffic on the same VC.

**Figure 7: ATM VC Bundle PVC Selection for Packet Transfer**

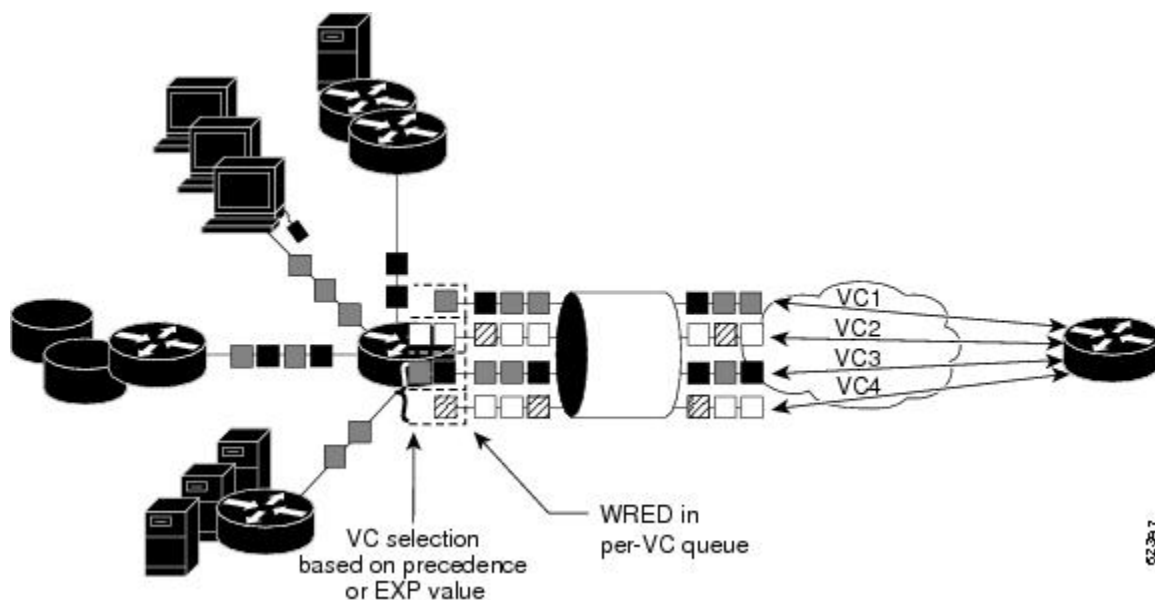

The support of multiple parallel ATM VCs allows you to create stronger service differentiation at the IP layer. For instance, you might want to configure the network to provide IP traffic belonging to real-time class of service (CoS) (such as Voice over IP traffic) on an ATM VC with strict constraints (constant bit rate (CBR) or variable bit rate real-time (VBR-rt), for example), while also allowing the network to transport nonreal-time traffic over a more elastic ATM unspecified bit rate (UBR) PVC. UBR is effectively the ATM version of best-effort service. Using a configuration such as this would allow you to make full use of your network capacity.

## Benefits

### Improved System Performance

This feature is designed to provide a true working solution to class-based services, without the investment of new ATM network infrastructures. Now networks can offer different service classes (sometimes termed

*differential service classes*) across the entire WAN, not just the routed portion. Mission-critical applications can be given exceptional service during periods of high network usage and congestion. In addition, noncritical traffic can be restricted in its network usage, ensuring greater QoS for more important traffic and user types.

#### **Additional Selection Criteria**

This new feature now gives customers the option of using the MPLS EXP level, in addition to IP precedence, as a selection criteria for packet forwarding.

## **Restrictions**

- This feature requires ATM PVC management, as well as Forwarding Information Base (FIB) and Tag Forwarding Information Base (TFIB) switching functionality.
- This feature is not supported on either the ATM interface processor (AIP) or the ATM Lite port adapter (PA-A1).
- The router at the remote end of the network must be using a version of Cisco IOS that supports MPLS and ATM PVC management.

## **Related Features and Technologies**

This feature is similar to the IP to ATM Class of Service feature suite, which is documented in the "Configuring IP to ATM Class of Service" module.

## **Related Documents**

- Cisco IOS Quality of Service Solutions Command Reference
- Cisco IOS Switching Services Command Reference
- "Frame Relay PVC Bundles with QoS Support for IP and MPLS " module
- Cisco IOS Wide-Area Networking Command Reference
- "IP to ATM SVC Bundles for Class of Service (CoS) Mapping " module
- "MPLS Label Distribution Protocol (LDP) Overview " module

## **Supported Platforms**

- Cisco 3600 series

The ATM Adapter PA-A3 is not supported on either the Cisco 3620 router or the Cisco 3640 router. Because certain QoS features (for example, WRED) require the ATM Adapter PA-A3, specific limitations may apply. For more information about platform and feature support, refer to Cisco Feature Navigator (described below).

- Cisco 3725
- Cisco 3745

- Cisco 7200 series
- Cisco 7500 series

### Determining Platform Support Through Cisco Feature Navigator

Cisco IOS software is packaged in feature sets that support specific platforms. To get updated information regarding platform support for this feature, access Cisco Feature Navigator. Cisco Feature Navigator dynamically updates the list of supported platforms as new platform support is added for the feature.

Cisco Feature Navigator is a web-based tool that enables you to quickly determine which Cisco IOS software images support a specific set of features and which features are supported in a specific Cisco IOS image. You can search by feature or release. Under the release section, you can compare releases side by side to display both the features unique to each software release and the features in common.

To access Cisco Feature Navigator, you must have an account on Cisco.com. If you have forgotten or lost your account information, send a blank e-mail to [cco-locksmith@cisco.com](mailto:cco-locksmith@cisco.com). An automatic check will verify that your e-mail address is registered with Cisco.com. If the check is successful, account details with a new random password will be e-mailed to you. Qualified users can establish an account on Cisco.com by following the directions at <http://www.cisco.com/register>.

Cisco Feature Navigator is updated regularly when major Cisco IOS software releases and technology releases occur. For the most current information, go to the Cisco Feature Navigator home page at the following URL:

<http://www.cisco.com/go/fn>

## Supported Standards MIBs and RFCs

### Standards

No new or modified standards are supported by this feature.

### MIBs

No new or modified MIBs are supported by this feature.

To obtain lists of supported MIBs by platform and Cisco IOS release, and to download MIB modules, go to the Cisco MIB website on Cisco.com at the following URL:

<http://www.cisco.com/public/sw-center/netmgmt/cmtk/mibs.shtml>

### RFCs

No new or modified RFCs are supported by this feature.

## Configuration Tasks

See the following sections for configuration tasks for the ATM PVC Bundle Enhancement MPLS EXP-Based PVC Selection feature. Each task in the list is identified as either required or optional.

## Enabling MPLS

### SUMMARY STEPS

1. Router(config)# **ip cef**
2. Router(config)# **mpls label protocol ldp**
3. Router(config)# **interface** *type number* [*name-tag*]
4. Router(config-if)# **mpls ip**

### DETAILED STEPS

|               | Command or Action   | Purpose   |
|---------------|---|---|
| <b>Step 1</b> | Router(config)# <b>ip cef</b>   | Enables Cisco Express Forwarding (CEF) on the Route Processor (RP) card. An optional keyword <b>distributed</b> can be used with this command to enable distributed CEF (dCEF) for the Versatile Interface Processor (VIP)-based platforms. |
| <b>Step 2</b> | Router(config)# <b>mpls label protocol ldp</b>                          | Specifies the default label distribution protocol for a platform.   |
| <b>Step 3</b> | Router(config)# <b>interface</b> <i>type number</i> [ <i>name-tag</i> ] | Configures an interface type and enters interface configuration mode.   |
| <b>Step 4</b> | Router(config-if)# <b>mpls ip</b>                                       | Enables MPLS forwarding of IPv4 packets along normally routed paths for the platform.   |

## Creating a VC Bundle

| Command   | Purpose  |
|---|--|
| Device (config-if) # <b>bundle</b> <i>bundle-name</i> | Creates the specified bundle and enters bundle configuration mode. |

## Applying Parameters to Bundles

### Configuring Bundle-Level Parameters

| Command   | Purpose   |
|---|---|
| Router(config-if-atm-bundle)# <b>protocol</b> <i>protocol</i><br>{ <i>protocol-address</i>   <b>inarp</b> } [[ <b>no</b> ] <b>broadcast</b> ] | Configures a static map or enables Inverse Address Resolution Protocol (Inverse ARP) or Inverse ARP broadcasts for the bundle.<br><br><b>Note</b> Note that some parameters applied through a VC class or directly to the bundle can be superseded by commands that you directly apply to individual VCs in bundle-vc configuration mode. |
| Router(config-if-atm-bundle)# <b>encapsulation</b><br><i>aal-encap</i>  | Configures the ATM adaptation layer (AAL) and encapsulation type for the bundle.  |

### Configuring a VC Bundle Member Directly

| Command   | Purpose   |
|---|---|
| Router(config-if-atm-member)# <b>ubr</b> <i>output-pcr</i><br>[ <i>input-pcr</i> ]  | Configures the VC for UBR QoS and specifies the output peak cell rate (PCR) for it.   |
| Router(config-if-atm-member)# <b>vbr-nrt</b><br><i>output-pcr output-scr output-mbs</i> [ <i>input-pcr</i> ]<br>[ <i>input-scr</i> ] [ <i>input-mbs</i> ] | Configures the VC for variable bit rate nonreal-time (VBR-nrt) QoS and specifies the output PCR, output sustainable cell rate, and output maximum burst cell size for it. |
| Router(config-if-atm-member)# <b>mpls</b><br><b>experimental</b> [ <b>other</b>   <i>range</i> ]  | Configures the MPLS EXP levels for the VC.  |
| Router(config-if-atm-member)# <b>bump</b> { <b>implicit</b><br>  <b>explicit</b> <i>precedence-level</i>   <b>traffic</b> }                               | Configures the bumping rules for the VC.  |
| Router(config-if-atm-member)# <b>protect</b> { <b>group</b><br>  <b>vc</b> }  | Configures the VC to belong to the protected group of the bundle or to be an individually protected VC bundle member.   |

## Configuring VC Class Parameters to Apply to a Bundle

| Command   | Purpose  |
|---|--|
| Router(config-vc-class) # <b>oam-bundle</b> [manage]<br>[frequency] | Enables end-to-end F5 Operation, Administration, and Maintenance (OAM) loopback cell generation and OAM management for all VCs in the bundle.<br><br><b>Note</b> If you are using a VC class to configure the bundle, you must attach the VC class to the bundle. To do this, complete the procedure in the section " <a href="#">Attaching a Class to a Bundle, on page 42.</a> " |

## Attaching a Class to a Bundle

| Command  | Purpose   |
|--|---|
| Router(config-if-atm-bundle) # <b>class-bundle</b><br><i>vc-class-name</i> | Configures a bundle with the bundle-level commands contained in the specified VC class. |

## Verifying the Configuration

| Command   | Purpose   |
|---|---|
| Router# <b>debug atm bundle error</b>             | Displays debug messages for PVC bundle errors.  |
| Router# <b>debug atm bundle events</b>            | Displays PVC bundle events.   |
| Router# <b>show atm map</b>                       | Displays the list of all configured ATM static maps to remote hosts on an ATM network.                      |
| Router# <b>show atm bundle</b> <i>bundle-name</i> | Displays the bundle attributes assigned to each VC member and the current working status of the VC members. |
| Router# <b>show mpls forwarding-table</b>         | Displays the contents of the MPLS FIB.  |



# Configuration Examples

## Example VC Bundle Configuration Using a VC Class

This example configures VC bundle management on a router that uses Intermediate System-to-Intermediate System (IS-IS) as its IP routing protocol.

### Bundle-Class Class

At the outset, this configuration defines a VC class called "bundle-class," which includes commands that set VC parameters. When the class bundle-class is applied at the bundle level, these parameters are applied to all VCs that belong to the bundle. Note that any commands applied directly to an individual VC of a bundle in bundle-vc mode take precedence over commands applied globally at the bundle level. Taking into account hierarchy precedence rules, VCs belonging to any bundle to which the class bundle-class is applied will be characterized by the following parameters: aal5snap encapsulation, broadcast on, use of Inverse ARP to resolve IP addresses, and OAM enabled.

```
router isis
 net 49.0000.0000.0000.1111.00
vc-class atm bundle-class
 encapsulation aal5snap
 broadcast
 protocol ip inarp
 oam-bundle manage 3
 oam 4 3 10
```

The following four sections of the configuration define specific VC classes. Each of these classes contains commands used to specify parameters that can then be applied to individual VCs in a bundle by assigning the class to that VC.

### Control-Class Class

When the class called "control-class" is applied to a VC, the VC carries traffic whose MPLS EXP level is 7. When the VC to which this class is assigned goes down, it takes the bundle down with it because this class makes the VC a protected one. The QoS type of a VC using this class is vbr-nrt.

```
vc-class atm control-class
 mpls experimental 7
 protect vc
 vbr-nrt 1000 5000 32
```

### Premium-Class Class

When the class called "premium-class" is applied to a VC, the VC carries traffic whose MPLS EXP levels are 6 and 5. The VC does not allow other traffic to be bumped onto it. When the VC to which this class is applied goes down, its bumped traffic will be redirected to a VC whose MPLS EXP level is 7. This class makes a VC a member of the protected group of the bundle. When all members of a protected group go down, the bundle goes down. The QoS type of a VC using this class is vbr-nrt.

```
vc-class atm premium-class
 mpls experimental 6-5
```

```
no bump traffic
protect group
bump explicitly 7
vbr-rt 20000 10000 32
```

## Priority-Class Class

When the class called "priority-class" is applied to a VC, the VC is configured to carry traffic with an MPLS EXP level in the 4 - 2 range. The VC uses the implicit bumping rule, it allows traffic to be bumped, and it belongs to the protected group of the bundle. The QoS type of a VC using this class is ubr+.

```
vc-class atm priority-class
mpls experimental 4-2
protect group
ubr+ 10000 3000
```

## Basic-Class Class

When the class called "basic-class" is applied to a VC, the VC is configured through the **mpls experimental other** command to carry traffic with MPLS EXP levels not specified in the profile. The VC using this class belongs to the protected group of the bundle. The QoS type of a VC using this class is ubr.

```
vc-class atm basic-class
mpls experimental other
protect group
ubr 10000
```

The following sets of commands configure three bundles that the router subinterface uses to connect to three of its neighbors. These bundles are called "new-york," "san-francisco," and "los-angeles." Bundle new-york has four VC members, bundle san-francisco has four VC members, and bundle los-angeles has three VC members.

## new-york Bundle

The first part of this example specifies the IP address of the subinterface, the router protocol--the router uses IS-IS as an IP routing protocol--and it creates the first bundle called "new-york" and enters bundle configuration mode:

```
interface a1/0.1 multipoint
ip address 10.0.0.1 255.255.255.0
ip router isis
bundle new-york
```

From within bundle configuration mode, the next portion of the configuration uses two protocol commands to enable IP and Open Systems Interconnect (OSI) traffic flows in the bundle. The OSI routing packets will use the highest MPLS EXP VC in the bundle. The OSI data packets, if any, will use the lowest MPLS EXP VC in the bundle. If configured, other protocols, such as Internet Packet Exchange (IPX) or AppleTalk, will always use the lowest MPLS EXP VC in the bundle.

As the indentation levels of the preceding and following commands suggest, subordinate to bundle new-york is a command that configures its protocol and a command that applies the class called "bundle-class" to it.

```
protocol ip 1.1.1.2 broadcast
protocol clns 49.0000.0000.2222.00 broadcast
class-bundle bundle-class
```

The class called "bundle-class," which is applied to the bundle new-york, includes a **protocol ip inarp** command. According to inheritance rules, **protocol ip**, configured at the bundle level, takes precedence over **protocol ip inarp** specified in the class bundle-class.

The next set of commands beginning with **pvc-bundle ny-control 207**, which are further subordinate, add four VCs (called "ny-control," "ny-premium," "ny-priority," and "ny-basic") to the bundle new-york. A particular class--that is, one of the classes predefined in this configuration example--is applied to each VC to configure it with parameters specified by commands included in the class.

As is the case for this configuration, to configure individual VCs belonging to a bundle, the router must be in bundle mode for the mother bundle. For each VC belonging to the bundle, the subordinate mode is pvc-mode for the specific VC.

The following commands configure the individual VCs for the bundle new-york:

```
pvc-bundle ny-control 207
  class-vc control-class
pvc-bundle ny-premium 206
  class-vc premium-class
pvc-bundle ny-priority 204
  class-vc priority-class
pvc-bundle ny-basic 201
  class-vc basic-class
```

## san-francisco Bundle

The following set of commands create and configure a bundle called "san-francisco." At the bundle configuration level, the configuration commands included in the class bundle-class are ascribed to the bundle san-francisco and to the individual VCs that belong to the bundle. Then, the **pvc-bundle** command is executed for each individual VC to add it to the bundle. After a VC is added and bundle-vc configuration mode is entered, a particular, preconfigured class is assigned to the VC. The configuration commands comprising that class are used to configure the VC. Rules of hierarchy apply at this point. Command parameters contained in the applied class are superseded by the same parameters applied at the bundle configuration level, which are superseded by the same parameters applied directly to a VC.

```
bundle san-francisco
  protocol cls 49.0000.0000.0000.333.00 broadcast
  inarp 1
  class-bundle bundle-class
pvc-bundle sf-control 307
  class-vc control-class
pvc-bundle sf-premium 306
  class-vc premium-class
pvc-bundle sf-priority 304
  class-vc priority-class
pvc-bundle sf-basic 301
  class-vc basic-class
```

## los-angeles Bundle

The following set of commands create and configure a bundle called "los-angeles." At the bundle configuration level, the configuration commands included in the class bundle-class are ascribed to the bundle los-angeles and to the individual VCs that belong to the bundle. Then, the **pvc-bundle** command is executed for each individual VC to add it to the bundle. After a VC is added and bundle-vc configuration mode is entered, the MPLS EXP level is set for the VC, and the VC is either configured as a member of a protected group (protect group) or as an individually protected VC. A particular class is then assigned to each VC to further characterize it. Rules of hierarchy apply. Parameters of commands applied directly and discretely to a VC take precedence

over the same parameters applied within a class to the VC at the bundle-vc configuration level, which take precedence over the same parameters applied to the entire bundle at the bundle configuration level.

```
bundle los-angeles
  protocol ip 1.1.1.4 broadcast
  protocol clns 49.0000.0000.4444.00 broadcast
  inarp 1
  class-bundle bundle-class
  pvc-bundle la-high 407
    mpls experimental 7-5
    protect vc
    class-vc premium-class
  pvc-bundle la-mid 404
    mpls experimental 4-2
    protect group
    class-vc priority-class
  pvc-bundle la-low 401
    mpls experimental other
    protect group
    class-vc basic-class
```

## Command Reference

The following commands are introduced or modified in the feature or features documented in this module. For information about these commands, see the *Cisco IOS Quality of Service Solutions Command Reference* at [http://www.cisco.com/en/US/docs/ios/qos/command/reference/qos\\_book.html](http://www.cisco.com/en/US/docs/ios/qos/command/reference/qos_book.html). For information about all Cisco IOS commands, use the Command Lookup Tool at <http://tools.cisco.com/Support/CLILookup> or a Cisco IOS master commands list.

### New Commands

- **mpls experimental**

### Modified Commands

- **show mpls forwarding-table**