



## **Internet Key Exchange for IPsec VPNs Configuration Guide**

### **Americas Headquarters**

Cisco Systems, Inc.  
170 West Tasman Drive  
San Jose, CA 95134-1706  
USA  
<http://www.cisco.com>  
Tel: 408 526-4000  
800 553-NETS (6387)  
Fax: 408 527-0883

THE SPECIFICATIONS AND INFORMATION REGARDING THE PRODUCTS IN THIS MANUAL ARE SUBJECT TO CHANGE WITHOUT NOTICE. ALL STATEMENTS, INFORMATION, AND RECOMMENDATIONS IN THIS MANUAL ARE BELIEVED TO BE ACCURATE BUT ARE PRESENTED WITHOUT WARRANTY OF ANY KIND, EXPRESS OR IMPLIED. USERS MUST TAKE FULL RESPONSIBILITY FOR THEIR APPLICATION OF ANY PRODUCTS.

THE SOFTWARE LICENSE AND LIMITED WARRANTY FOR THE ACCOMPANYING PRODUCT ARE SET FORTH IN THE INFORMATION PACKET THAT SHIPPED WITH THE PRODUCT AND ARE INCORPORATED HEREIN BY THIS REFERENCE. IF YOU ARE UNABLE TO LOCATE THE SOFTWARE LICENSE OR LIMITED WARRANTY, CONTACT YOUR CISCO REPRESENTATIVE FOR A COPY.

The Cisco implementation of TCP header compression is an adaptation of a program developed by the University of California, Berkeley (UCB) as part of UCB's public domain version of the UNIX operating system. All rights reserved. Copyright © 1981, Regents of the University of California.

NOTWITHSTANDING ANY OTHER WARRANTY HEREIN, ALL DOCUMENT FILES AND SOFTWARE OF THESE SUPPLIERS ARE PROVIDED "AS IS" WITH ALL FAULTS. CISCO AND THE ABOVE-NAMED SUPPLIERS DISCLAIM ALL WARRANTIES, EXPRESSED OR IMPLIED, INCLUDING, WITHOUT LIMITATION, THOSE OF MERCHANTABILITY, FITNESS FOR A PARTICULAR PURPOSE AND NON-INFRINGEMENT OR ARISING FROM A COURSE OF DEALING, USAGE, OR TRADE PRACTICE.

IN NO EVENT SHALL CISCO OR ITS SUPPLIERS BE LIABLE FOR ANY INDIRECT, SPECIAL, CONSEQUENTIAL, OR INCIDENTAL DAMAGES, INCLUDING, WITHOUT LIMITATION, LOST PROFITS OR LOSS OR DAMAGE TO DATA ARISING OUT OF THE USE OR INABILITY TO USE THIS MANUAL, EVEN IF CISCO OR ITS SUPPLIERS HAVE BEEN ADVISED OF THE POSSIBILITY OF SUCH DAMAGES.

Any Internet Protocol (IP) addresses and phone numbers used in this document are not intended to be actual addresses and phone numbers. Any examples, command display output, network topology diagrams, and other figures included in the document are shown for illustrative purposes only. Any use of actual IP addresses or phone numbers in illustrative content is unintentional and coincidental.

All printed copies and duplicate soft copies of this document are considered uncontrolled. See the current online version for the latest version.

Cisco has more than 200 offices worldwide. Addresses and phone numbers are listed on the Cisco website at [www.cisco.com/go/offices](http://www.cisco.com/go/offices).

Cisco and the Cisco logo are trademarks or registered trademarks of Cisco and/or its affiliates in the U.S. and other countries. To view a list of Cisco trademarks, go to this URL: <https://www.cisco.com/c/en/us/about/legal/trademarks.html>. Third-party trademarks mentioned are the property of their respective owners. The use of the word partner does not imply a partnership relationship between Cisco and any other company. (1721R)

© 2021 Cisco Systems, Inc. All rights reserved.



## CONTENTS

---

### CHAPTER 1

#### **Read Me First 1**

Short Description 2

---

### CHAPTER 2

#### **Configuring Internet Key Exchange for IPsec VPNs 3**

Finding Feature Information 3

Prerequisites for IKE Configuration 4

Restrictions for IKE Configuration 4

Information About Configuring IKE for IPsec VPNs 5

Supported Standards for Use with IKE 5

IKE Benefits 6

IKE Main Mode and Aggressive Mode 7

IKE Policies Security Parameters for IKE Negotiation 7

About IKE Policies 7

IKE Peers Agreeing Upon a Matching IKE Policy 8

IKE Authentication 8

RSA Signatures 8

RSA Encrypted Nonces 9

Preshared Keys 9

IKE Mode Configuration 10

How to Configure IKE for IPsec VPNs 10

Creating IKE Policies 11

Troubleshooting Tips 14

What to Do Next 14

Configuring IKE Authentication 14

Prerequisites 15

Configuring RSA Keys Manually for RSA Encrypted Nonces 15

- Configuring Preshared Keys 18
- Configuring IKE Mode Configuration 20
- Configuring an IKE Crypto Map for IPsec SA Negotiation 20
- Configuration Examples for an IKE Configuration 22
  - Example: Creating IKE Policies 22
    - Example: Creating 3DES IKE Policies 22
    - Example: Creating an AES IKE Policy 23
  - Example: Configuring IKE Authentication 23
- Where to Go Next 24
- Additional References 24
- Feature Information for Configuring IKE for IPsec VPNs 26

---

**CHAPTER 3**

- Call Admission Control for IKE 27**
  - Finding Feature Information 27
  - Prerequisites for Call Admission Control for IKE 27
  - Information About Call Admission Control for IKE 27
    - IKE Session 27
    - Security Association Limit 28
    - Limit on Number of In-Negotiation IKE Connections 28
    - System Resource Usage 28
  - How to Configure Call Admission Control for IKE 29
    - Configuring the IKE Security Association Limit 29
      - Configuring the IKEv2 Security Association Limit 30
    - Configuring the System Resource Limit 30
  - Verifying the Call Admission Control for IKE Configuration 31
  - Configuration Examples for Call Admission Control for IKE 32
    - Example Configuring the IKE Security Association Limit 32
    - Example Configuring the System Resource Limit 32
  - Additional References 33
  - Feature Information for Call Admission Control for IKE 34

---

**CHAPTER 4**

- Certificate to ISAKMP Profile Mapping 35**
  - Finding Feature Information 35
  - Prerequisites for Certificate to ISAKMP Profile Mapping 35

Restrictions for Certificate to ISAKMP Profile Mapping	36
Information About Certificate to ISAKMP Profile Mapping	36
Certificate to ISAKMP Profile Mapping Overview	36
How Certificate to ISAKMP Profile Mapping Works	36
Assigning an ISAKMP Profile and Group Name to a Peer	37
How to Configure Certificate to ISAKMP Profile Mapping	37
Mapping the Certificate to the ISAKMP Profile	37
Verifying That the Certificate Has Been Mapped	38
Assigning the Group Name to the Peer	39
Monitoring and Maintaining Your Certificate to ISAKMP Profile Mapping	39
Configuration Examples for Certificate to ISAKMP Profile Mapping	40
Certificates Mapped to the ISAKMP Profile on the Basis of Arbitrary Fields Example	40
Group Name Assigned to a Peer That Is Associated with an ISAKMP Profile Example	40
Mapping a Certificate to an ISAKMP Profile Verification Example	41
Group Name Assigned to a Peer Verification Example	42
Additional References	43
Feature Information for Certificate to ISAKMP Profile Mapping	44

---

**CHAPTER 5**
**Encrypted Preshared Key 45**

Finding Feature Information	45
Restrictions for Encrypted Preshared Key	45
Information About Encrypted Preshared Key	46
Using the Encrypted Preshared Key Feature to Securely Store Passwords	46
Changing a Password	46
Deleting a Password	46
Unconfiguring Password Encryption	46
Storing Passwords	46
Configuring New or Unknown Passwords	47
Enabling the Encrypted Preshared Key	47
How to Configure an Encrypted Preshared Key	47
Configuring an Encrypted Preshared Key	47
Troubleshooting Tips	48
Monitoring Encrypted Preshared Keys	48
What To Do Next	49

Configuring an ISAKMP Preshared Key	49
Configuring an ISAKMP Preshared Key in ISAKMP Keyrings	50
Configuring ISAKMP Aggressive Mode	51
Configuring a Unity Server Group Policy	52
Configuring an Easy VPN Client	54
Configuration Examples for Encrypted Preshared Key	55
Encrypted Preshared Key Example	55
No Previous Key Present Example	56
Key Already Exists Example	56
Key Already Exists But the User Wants to Key In Interactively Example	56
No Key Present But the User Wants to Key In Interactively Example	56
Removal of the Password Encryption Example	56
Where to Go Next	56
Additional References	57
Related Documents	57
Standards	57
MIBs	57
RFCs	57
Technical Assistance	57

---

**CHAPTER 6**

<b>Distinguished Name Based Crypto Maps</b>	<b>59</b>
Finding Feature Information	59
Feature Overview	60
Benefits	60
Restrictions	60
Related Documents	60
Supported Platforms	60
Supported Standards MIBs and RFCs	61
Prerequisites	61
Configuration Tasks	62
Configuring DN Based Crypto Maps (authenticated by DN)	62
Configuring DN Based Crypto Maps (authenticated by hostname)	62
Applying Identity to DN Based Crypto Maps	63
Verifying DN Based Crypto Maps	63

Troubleshooting Tips	64
Configuration Examples	64
DN Based Crypto Map Configuration Example	64

**CHAPTER 7****IPsec and Quality of Service 65**

Finding Feature Information	65
Prerequisites for IPsec and Quality of Service	66
Restrictions for IPsec and Quality of Service	66
Information About IPsec and Quality of Service	66
IPsec and Quality of Service Overview	66
How to Configure IPsec and Quality of Service	66
Configuring IPsec and Quality of Service	66
Verifying IPsec and Quality of Service Sessions	67
Troubleshooting Tips	68
Configuration Examples for IPsec and Quality of Service	68
QoS Policy Applied to Two Groups of Remote Users Example	68
show crypto isakmp profile Command Example	70
show crypto ipsec sa Command Example	70
Additional References	71
Related Documents	71
Standards	71
MIBs	71
RFCs	71
Technical Assistance	72
Feature Information for IPsec and Quality of Service	72

**CHAPTER 8****VRF-Aware IPsec 73**

Finding Feature Information	73
Restrictions for VRF-Aware IPsec	73
Information About VRF-Aware IPsec	74
VRF Instance	74
MPLS Distribution Protocol	74
VRF-Aware IPsec Functional Overview	74
Packet Flow into the IPsec Tunnel	75

Packet Flow from the IPsec Tunnel	75
How to Configure VRF-Aware IPsec	76
Configuring Crypto Keyrings	76
Configuring ISAKMP Profiles	78
What to Do Next	81
Configuring an ISAKMP Profile on a Crypto Map	82
Configuring to Ignore Extended Authentication During IKE Phase 1 Negotiation	83
Verifying VRF-Aware IPsec	83
Clearing Security Associations	84
Troubleshooting VRF-Aware IPsec	85
Debug Examples for VRF-Aware IPsec	85
Configuration Examples for VRF-Aware IPsec	93
Example Static IPsec-to-MPLS VPN	93
Example IPsec-to-MPLS VPN Using RSA Encryption	95
Example IPsec-to-MPLS VPN with RSA Signatures	96
Example IPsec Remote Access-to-MPLS VPN	98
Upgrade from Previous Versions of the Cisco Network-Based IPsec VPN Solution	99
Site-to-Site Configuration Upgrade	99
Remote Access Configuration Upgrade	100
Combination Site-to-Site and Remote Access Configuration Upgrade	102
Additional References	105
Feature Information for VRF-Aware IPsec	106
Glossary	106

---

**CHAPTER 9**

<b>IKE Initiate Aggressive Mode</b>	<b>109</b>
Finding Feature Information	109
Prerequisites for IKE Initiate Aggressive Mode	109
Restrictions for IKE Initiate Aggressive Mode	110
Information About IKE Initiate Aggressive Mode	110
Overview	110
RADIUS Tunnel Attributes	110
How to Configure IKE Initiate Aggressive Mode	111
Configuring RADIUS Tunnel Attributes	111
Verifying RADIUS Tunnel Attribute Configurations	112



Troubleshooting Tips	112
Configuration Examples for IKE Initiate Aggressive Mode	113
Hub Configuration Example	113
Spoke Configuration Example	113
RADIUS User Profile Example	114
Additional References	114
Feature Information for IKE Initiate Aggressive Mode	115





# CHAPTER 1

## Read Me First

---

### Important Information



---

**Note** For CUBE feature support information in Cisco IOS XE Bengaluru 17.6.1a and later releases, see [Cisco Unified Border Element IOS-XE Configuration Guide](#).

---



---

**Note** The documentation set for this product strives to use bias-free language. For purposes of this documentation set, bias-free is defined as language that does not imply discrimination based on age, disability, gender, racial identity, ethnic identity, sexual orientation, socioeconomic status, and intersectionality. Exceptions may be present in the documentation due to language that is hardcoded in the user interfaces of the product software, language used based on standards documentation, or language that is used by a referenced third-party product.

---

### Feature Information

Use [Cisco Feature Navigator](#) to find information about feature support, platform support, and Cisco software image support. An account on Cisco.com is not required.

### Related References

- [Cisco IOS Command References, All Releases](#)

### Obtaining Documentation and Submitting a Service Request

- To receive timely, relevant information from Cisco, sign up at [Cisco Profile Manager](#).
- To get the business impact you're looking for with the technologies that matter, visit [Cisco Services](#).
- To submit a service request, visit [Cisco Support](#).
- To discover and browse secure, validated enterprise-class apps, products, solutions and services, visit [Cisco Marketplace](#).
- To obtain general networking, training, and certification titles, visit [Cisco Press](#).
- To find warranty information for a specific product or product family, access [Cisco Warranty Finder](#).

- [Short Description, on page 2](#)

## Short Description

Cisco and the Cisco logo are trademarks or registered trademarks of Cisco and/or its affiliates in the U.S. and other countries. To view a list of Cisco trademarks, go to this URL: <https://www.cisco.com/c/en/us/about/legal/trademarks.html>. Third-party trademarks mentioned are the property of their respective owners. The use of the word partner does not imply a partnership relationship between Cisco and any other company. (1721R)



## CHAPTER 2

# Configuring Internet Key Exchange for IPsec VPNs

This module describes how to configure the Internet Key Exchange (IKE) protocol for basic IP Security (IPsec) Virtual Private Networks (VPNs). IKE is a key management protocol standard that is used in conjunction with the IPsec standard. IPsec is an IP security feature that provides robust authentication and encryption of IP packets.

IPsec can be configured without IKE, but IKE enhances IPsec by providing additional features, flexibility, and ease of configuration for the IPsec standard.

IKE is a hybrid protocol, that implements the Oakley key exchange and Skeme key exchange inside the Internet Security Association Key Management Protocol (ISAKMP) framework. (ISAKMP, Oakley, and Skeme are security protocols implemented by IKE.)



**Note** Security threats, as well as the cryptographic technologies to help protect against them, are constantly changing. For more information about the latest Cisco cryptographic recommendations, see the [Next Generation Encryption](#) (NGE) white paper.

- [Finding Feature Information, on page 3](#)
- [Prerequisites for IKE Configuration, on page 4](#)
- [Restrictions for IKE Configuration, on page 4](#)
- [Information About Configuring IKE for IPsec VPNs, on page 5](#)
- [How to Configure IKE for IPsec VPNs, on page 10](#)
- [Configuration Examples for an IKE Configuration, on page 22](#)
- [Where to Go Next, on page 24](#)
- [Additional References, on page 24](#)
- [Feature Information for Configuring IKE for IPsec VPNs, on page 26](#)

## Finding Feature Information

Your software release may not support all the features documented in this module. For the latest caveats and feature information, see [Bug Search Tool](#) and the release notes for your platform and software release. To find information about the features documented in this module, and to see a list of the releases in which each feature is supported, see the feature information table.

Use Cisco Feature Navigator to find information about platform support and Cisco software image support. To access Cisco Feature Navigator, go to <https://cfng.cisco.com/>. An account on Cisco.com is not required.

## Prerequisites for IKE Configuration

- You should be familiar with the concepts and tasks explained in the module [Configuring Security for VPNs with IPsec](#).
- Ensure that your Access Control Lists (ACLs) are compatible with IKE. Because IKE negotiation uses User Datagram Protocol (UDP) on port 500, your ACLs must be configured so that UDP port 500 traffic is not blocked at interfaces used by IKE and IPsec. In some cases you might need to add a statement to your ACLs to explicitly permit UDP port 500 traffic.

## Restrictions for IKE Configuration

- To avoid profiles being locked or leading to DMI degrade state, before using the **config-replace** command to replace a configuration, ensure to shut down the tunnel interface to bring down all crypto sessions, and tunnel configurations.
- The initiating router *must not* have a certificate associated with the remote peer.
- The preshared key *must* be by a fully qualified domain name (FQDN) on both peers. (To configure the preshared key, enter the **crypto isakmp key** command.)
- The communicating routers *must* have a FQDN host entry for each other in their configurations.
- The communicating routers *must* be configured to authenticate by hostname, *not* by IP address; thus, you should use the **crypto isakmp identity hostname** command.
- Use **show crypto eli** command to determine the software encryption limitations for your device. Without any hardware modules, the limitations are as follows:
  - 1000 IPsec security associations (SAs)
  - 100 IKE SAs
  - 50 Diffie-Hellman (DH) session keys
- Disable the crypto batch functionality, by using the **no crypto batch allowed** command to increase the performance of a TCP flow on a Site-to-site VPN. However, disabling the crypto batch functionality might have an impact on CPU utilization.
- Starting with Cisco IOS Release 15.0(1)SY and later, you cannot configure IPsec Network Security features using **crypto ipsec** commands on Cisco Catalyst 6500 Series switches. For IPsec support on these switches, you must use a hardware encryption engine.

# Information About Configuring IKE for IPsec VPNs

## Supported Standards for Use with IKE

Cisco implements the following standards:

- **IPsec**—IP Security Protocol. IPsec is a framework of open standards that provides data confidentiality, data integrity, and data authentication between participating peers. IPsec provides these security services at the IP layer; it uses IKE to handle negotiation of protocols and algorithms based on local policy and to generate the encryption and authentication keys to be used by IPsec. IPsec can be used to protect one or more data flows between a pair of hosts, between a pair of security gateways, or between a security gateway and a host.
- **ISAKMP**—Internet Security Association and Key Management Protocol. A protocol framework that defines payload formats, the mechanics of implementing a key exchange protocol, and the negotiation of a security association.
- **Oakley**—A key exchange protocol that defines how to derive authenticated keying material.
- **Skeme**—A key exchange protocol that defines how to derive authenticated keying material, with rapid key refreshment.



---

**Note**

Cisco no longer recommends using DES, 3DES, MD5 (including HMAC variant), and Diffie-Hellman (DH) groups 1, 2 and 5; instead, you should use AES, SHA-256 and DH Groups 14 or higher. For more information about the latest Cisco cryptographic recommendations, see the [Next Generation Encryption \(NGE\)](#) white paper.

---

The component technologies implemented for use by IKE include the following:

- **AES**—Advanced Encryption Standard. A cryptographic algorithm that protects sensitive, unclassified information. AES is privacy transform for IPsec and IKE and has been developed to replace the Data Encryption Standard (DES). AES is designed to be more secure than DES: AES offers a larger key size, while ensuring that the only known approach to decrypt a message is for an intruder to try every possible key. AES has a variable key length—the algorithm can specify a 128-bit key (the default), a 192-bit key, or a 256-bit key.
- **DES**—Data Encryption Standard. An algorithm that is used to encrypt packet data. IKE implements the 56-bit DES-CBC with Explicit IV standard. Cipher Block Chaining (CBC) requires an initialization vector (IV) to start encryption. The IV is explicitly given in the IPsec packet.

Cisco IOS software also implements Triple DES (168-bit) encryption, depending on the software versions available for a specific platform. Triple DES (3DES) is a strong form of encryption that allows sensitive information to be transmitted over untrusted networks. It enables customers, particularly in the finance industry, to utilize network-layer encryption.



**Note** Cisco IOS images that have strong encryption (including, but not limited to, 56-bit data encryption feature sets) are subject to United States government export controls, and have a limited distribution. Images that are to be installed outside the United States require an export license. Customer orders might be denied or subject to delay because of United States government regulations. Contact your sales representative or distributor for more information, or send e-mail to [export@cisco.com](mailto:export@cisco.com).

- **SEAL**—Software Encryption Algorithm. An alternative algorithm to software-based DES, 3DES, and AES. SEAL encryption uses a 160-bit encryption key and has a lower impact to the CPU when compared to other software-based algorithms.
- **SHA-2 and SHA-1 family (HMAC variant)**—Secure Hash Algorithm (SHA) 1 and 2. Both SHA-1 and SHA-2 are hash algorithms used to authenticate packet data and verify the integrity verification mechanisms for the IKE protocol. HMAC is a variant that provides an additional level of hashing. SHA-2 family adds the SHA-256 bit hash algorithm and SHA-384 bit hash algorithm. This functionality is part of the Suite-B requirements that comprises four user interface suites of cryptographic algorithms for use with IKE and IPsec that are described in RFC 4869. Each suite consists of an encryption algorithm, a digital signature algorithm, a key agreement algorithm, and a hash or message digest algorithm. See the Configuring Security for VPNs with IPsec feature module for more detailed information about Cisco IOS Suite-B support.
- **RSA signatures and RSA encrypted nonces**—RSA is the public key cryptographic system developed by Ron Rivest, Adi Shamir, and Leonard Adleman. RSA signatures provide nonrepudiation, and RSA encrypted nonces provide repudiation. (Repudiation and nonrepudiation have to do with traceability.)
- **Diffie-Hellman**—A public-key cryptography protocol that allows two parties to establish a shared secret over an unsecure communications channel. Diffie-Hellman is used within IKE to establish session keys. It supports 768-bit (the default), 1024-bit, 1536-bit, 2048-bit, 3072-bit, and 4096-bit DH groups. It also supports a 2048-bit DH group with a 256-bit subgroup, and 256-bit and 384-bit elliptic curve DH (ECDH). Cisco recommends using 2048-bit or larger DH key exchange, or ECDH key exchange.
- **MD5**—Message Digest 5 (Hash-Based Message Authentication Code (HMAC) variant). A hash algorithm used to authenticate packet data. HMAC is a variant that provides an additional level of hashing.

IKE interoperates with the X.509v3 certificates, which are used with the IKE protocol when authentication requires public keys. This certificate support allows the protected network to scale by providing the equivalent of a digital ID card to each device. When two devices intend to communicate, they exchange digital certificates to prove their identity (thus removing the need to manually exchange public keys with each peer or to manually specify a shared key at each peer).

## IKE Benefits

IKE automatically negotiates IPsec security associations (SAs) and enables IPsec secure communications without costly manual preconfiguration. Specifically, IKE provides the following benefits:

- Allows you to specify a lifetime for the IPsec SA.
- Allows encryption keys to change during IPsec sessions.
- Allows IPsec to provide antireplay services.
- Permits certification authority (CA) support for a manageable, scalable IPsec implementation.



- Allows dynamic authentication of peers.

## IKE Main Mode and Aggressive Mode

IKE has two phases of key negotiation: phase 1 and phase 2. Phase 1 negotiates a security association (a key) between two IKE peers. The key negotiated in phase 1 enables IKE peers to communicate securely in phase 2. During phase 2 negotiation, IKE establishes keys (security associations) for other applications, such as IPsec.

Phase 1 negotiation can occur using main mode or aggressive mode. Main mode tries to protect all information during the negotiation, meaning that no information is available to a potential attacker. When main mode is used, the identities of the two IKE peers are hidden. Although this mode of operation is very secure, it is relatively costly in terms of the time required to complete the negotiation. Aggressive mode takes less time to negotiate keys between peers; however, it gives up some of the security provided by main mode negotiation. For example, the identities of the two parties trying to establish a security association are exposed to an eavesdropper.

The two modes serve different purposes and have different strengths. Main mode is slower than aggressive mode, but main mode is more secure and more flexible because it can offer an IKE peer more security proposals than aggressive mode. Aggressive mode is less flexible and not as secure, but much faster.

In Cisco IOS software, the two modes are not configurable. The default action for IKE authentication (rsa-sig, rsa-encr, or preshared) is to initiate main mode; however, in cases where there is no corresponding information to initiate authentication, and there is a preshared key associated with the hostname of the peer, Cisco IOS software can initiate aggressive mode. Cisco IOS software will respond in aggressive mode to an IKE peer that initiates aggressive mode.

## IKE Policies Security Parameters for IKE Negotiation

An IKE policy defines a combination of security parameters to be used during the IKE negotiation. You must create an IKE policy at each peer participating in the IKE exchange.

If you do not configure any IKE policies, your router will use the default policy, which is always set to the lowest priority and which contains the default value of each parameter.

### About IKE Policies

Because IKE negotiations must be protected, each IKE negotiation begins by agreement of both peers on a common (shared) IKE policy. This policy states which security parameters will be used to protect subsequent IKE negotiations and mandates how the peers are authenticated.

After the two peers agree upon a policy, the security parameters of the policy are identified by an SA established at each peer, and these SAs apply to all subsequent IKE traffic during the negotiation.

You can configure multiple, prioritized policies on each peer--each with a different combination of parameter values. However, at least one of these policies must contain exactly the same encryption, hash, authentication, and Diffie-Hellman parameter values as one of the policies on the remote peer. For each policy that you create, you assign a unique priority (1 through 10,000, with 1 being the highest priority).



---

**Tip** If you are interoperating with a device that supports only one of the values for a parameter, your choice is limited to the value supported by the other device. Aside from this limitation, there is often a trade-off between security and performance, and many of these parameter values represent such a trade-off. You should evaluate the level of security risks for your network and your tolerance for these risks.

---

## IKE Peers Agreeing Upon a Matching IKE Policy

When the IKE negotiation begins, IKE searches for an IKE policy that is the same on both peers. The peer that initiates the negotiation will send all its policies to the remote peer, and the remote peer will try to find a match. The remote peer looks for a match by comparing its own highest priority policy against the policies received from the other peer. The remote peer checks each of its policies in order of its priority (highest priority first) until a match is found.

A match is made when both policies from the two peers contain the same encryption, hash, authentication, and Diffie-Hellman parameter values.

If a match is found, IKE will complete negotiation, and IPsec security associations will be created. If no acceptable match is found, IKE refuses negotiation and IPsec will not be established.



---

**Note** The parameter values apply to the IKE negotiations after the IKE SA is established. Depending on the authentication method specified in a policy, additional configuration might be required (as described in the section [IKE Authentication, on page 8](#)). If a peer's policy does not have the required companion configuration, the peer will not submit the policy when attempting to find a matching policy with the remote peer.

---

## IKE Authentication

IKE authentication consists of the following options and each authentication method requires additional configuration.

### RSA Signatures

With RSA signatures, you can configure the peers to obtain certificates from a CA. (The CA must be properly configured to issue the certificates.) Using a CA can dramatically improve the manageability and scalability of your IPsec network. Additionally, RSA signature-based authentication uses only two public key operations, whereas RSA encryption uses four public key operations, making it costlier in terms of overall performance. To properly configure CA support, see the module “Deploying RSA Keys Within a PKI.”

The certificates are used by each peer to exchange public keys securely. (RSA signatures requires that each peer has the public signature key of the remote peer.) When both peers have valid certificates, they will automatically exchange public keys with each other as part of any IKE negotiation in which RSA signatures are used.

You can also exchange the public keys manually, as described in the section “[Configuring RSA Keys Manually for RSA Encrypted Nonces, on page 15](#).”

RSA signatures provide nonrepudiation for the IKE negotiation. And, you can prove to a third party after the fact that you did indeed have an IKE negotiation with the remote peer.

## RSA Encrypted Nonces

With RSA encrypted nonces, you must ensure that each peer has the public keys of the other peers.

Unlike RSA signatures, the RSA encrypted nonces method cannot use certificates to exchange public keys. Instead, you ensure that each peer has the other's public keys by one of the following methods:

- Manually configuring RSA keys as described in the section “[Configuring RSA Keys Manually for RSA Encrypted Nonces, on page 15.](#)”
- Ensuring that an IKE exchange using RSA signatures with certificates has already occurred between the peers. (The peers' public keys are exchanged during the RSA-signatures-based IKE negotiations if certificates are used.) To make that the IKE exchange happens, specify two policies: a higher-priority policy with RSA encrypted nonces and a lower-priority policy with RSA signatures. When IKE negotiations occur, RSA signatures will be used the first time because the peers do not yet have each other's public keys. Then future IKE negotiations can use RSA encrypted nonces because the public keys will have been exchanged. This alternative requires that you already have CA support configured.

RSA encrypted nonces provide repudiation for the IKE negotiation; however, unlike RSA signatures, you cannot prove to a third party that you had an IKE negotiation with the remote peer.

## Preshared Keys

### Preshared Keys An Overview

Preshared keys are clumsy to use if your secured network is large, and they do not scale well with a growing network. However, they do not require use of a CA, as do RSA signatures, and might be easier to set up in a small network with fewer than ten nodes. RSA signatures also can be considered more secure when compared with preshared key authentication.



---

**Note** If RSA encryption is configured and signature mode is negotiated (and certificates are used for signature mode), the peer will request both signature and encryption keys. Basically, the router will request as many keys as the configuration will support. If RSA encryption is not configured, it will just request a signature key.

---

### ISAKMP Identity Setting for Preshared Keys

You should set the ISAKMP identity for each peer that uses preshared keys in an IKE policy.

When two peers use IKE to establish IPsec SAs, each peer sends its identity to the remote peer. Each peer sends either its hostname or its IP address, depending on how you have set the ISAKMP identity of the router.

By default, a peer's ISAKMP identity is the IP address of the peer. If appropriate, you could change the identity to be the peer's hostname instead. As a general rule, set the identities of all peers the same way--either all peers should use their IP addresses or all peers should use their hostnames. If some peers use their hostnames and some peers use their IP addresses to identify themselves to each other, IKE negotiations could fail if the identity of a remote peer is not recognized and a Domain Name System (DNS) lookup is unable to resolve the identity.

## Mask Preshared Keys

A mask preshared key allows a group of remote users with the same level of authentication to share an IKE preshared key. The preshared key of the remote peer must match the preshared key of the local peer for IKE authentication to occur.

A mask preshared key is usually distributed through a secure out-of-band channel. In a remote peer-to-local peer scenario, any remote peer with the IKE preshared key configured can establish IKE SAs with the local peer.

If you specify the **mask** keyword with the **crypto isakmp key** command, it is up to you to use a subnet address, which will allow more peers to share the same key. That is, the preshared key is no longer restricted to use between two users.



---

**Note** Using 0.0.0.0 as a subnet address is not recommended because it encourages group preshared keys, which allow all peers to have the same group key, thereby reducing the security of your user authentication.

---

### Disable Xauth on a Specific IPsec Peer

Disabling Extended Authentication (Xauth) for static IPsec peers prevents the routers from being prompted for Xauth information--username and password.

## IKE Mode Configuration

IKE mode configuration, as defined by the Internet Engineering Task Force (IETF), allows a gateway to download an IP address (and other network-level configuration) to the client as part of an IKE negotiation. Using this exchange, the gateway gives an IP address to the IKE client to be used as an “inner” IP address encapsulated under IPsec. This method provides a known IP address for the client that can be matched against IPsec policy.

To implement IPsec VPNs between remote access clients that have dynamic IP addresses and a corporate gateway, you have to dynamically administer scalable IPsec policy on the gateway once each client is authenticated. With IKE mode configuration, the gateway can set up a scalable policy for a very large set of clients regardless of the IP addresses of those clients.

There are two types of IKE mode configuration:

- Gateway initiation--Gateway initiates the configuration mode with the client. Once the client responds, the IKE modifies the identity of the sender, the message is processed, and the client receives a response.
- Client initiation--Client initiates the configuration mode with the gateway. The gateway responds with an IP address that it has allocated for the client.

## How to Configure IKE for IPsec VPNs

If you do not want IKE to be used with your IPsec implementation, you can disable it at all IPsec peers via the **no crypto isakmp** command, skip the rest of this chapter, and begin your IPsec VPN.

IKE is enabled by default. IKE does not have to be enabled for individual interfaces, but it is enabled globally for all interfaces at the router.



**Note** Security threats, as well as the cryptographic technologies to help protect against them, are constantly changing. For more information about the latest Cisco cryptographic recommendations, see the [Next Generation Encryption \(NGE\)](#) white paper.

Perform the following tasks to provide authentication of IPsec peers, negotiate IPsec SAs, and establish IPsec keys:

## Creating IKE Policies

### Before you begin

The following restrictions apply if you are configuring an AES IKE policy:

- Your device must support IPsec and long keys (the “k9” subsystem).
- AES cannot encrypt IPsec and IKE traffic if an acceleration card is present.

### SUMMARY STEPS

1. **enable**
2. **configure terminal**
3. **crypto isakmp policy *priority***
4. **encryption {des | 3des | aes | aes 192 | aes 256}**
5. **hash {sha | sha256 | sha384 | md5}**
6. **authentication {rsa-sig | rsa-encr | pre-share}**
7. **group {1 | 2 | 5 | 14 | 15 | 16 | 19 | 20 | 24}**
8. **lifetime *seconds***
9. **exit**
10. **exit**
11. **show crypto isakmp policy**
12. Repeat these steps for each policy you want to create.

### DETAILED STEPS

	Command or Action	Purpose
Step 1	<b>enable</b> <b>Example:</b> Router> enable	Enables privileged EXEC mode.  • Enter your password if prompted.
Step 2	<b>configure terminal</b> <b>Example:</b> Router# configure terminal	Enters global configuration mode.
Step 3	<b>crypto isakmp policy <i>priority</i></b> <b>Example:</b>	Defines an IKE policy and enters config-isakmp configuration mode.

	Command or Action	Purpose
	<code>Router(config)# crypto isakmp policy 10</code>	<ul style="list-style-type: none"> <li>• <i>priority</i>—Uniquely identifies the IKE policy and assigns a priority to the policy. Valid values: 1 to 10,000; 1 is the highest priority.</li> </ul>
<b>Step 4</b>	<b>encryption {des   3des   aes   aes 192   aes 256}</b> <b>Example:</b> <code>Router(config-isakmp)# encryption aes 256</code>	Specifies the encryption algorithm. <ul style="list-style-type: none"> <li>• By default, the <b>des</b> keyword is used.               <ul style="list-style-type: none"> <li>• <b>des</b>—56-bit DES-CBC (No longer recommended. AES is the recommended encryption algorithm)</li> <li>• <b>3des</b>—168-bit DES (No longer recommended. AES is the recommended encryption algorithm)</li> <li>• <b>aes</b>—128-bit AES</li> <li>• <b>aes 192</b>—192-bit AES</li> <li>• <b>aes 256</b>—256-bit AES</li> </ul> </li> </ul>
<b>Step 5</b>	<b>hash {sha   sha256   sha384   md5}</b> <b>Example:</b> <code>Router(config-isakmp)# hash sha</code>	Specifies the hash algorithm. <ul style="list-style-type: none"> <li>• By default, SHA-1 (<b>sha</b>) is used.</li> <li>• The <b>sha256</b> keyword specifies SHA-2 family 256-bit (HMAC variant) as the hash algorithm.</li> <li>• The <b>sha384</b> keyword specifies SHA-2 family 384-bit (HMAC variant) as the hash algorithm.</li> <li>• The <b>md5</b> keyword specifies MD5 (HMAC variant) as the hash algorithm. (No longer recommended. SHA-256 is the recommended replacement.)</li> </ul>
<b>Step 6</b>	<b>authentication {rsa-sig   rsa-encr   pre-share}</b> <b>Example:</b> <code>Router(config-isakmp)# authentication pre-share</code>	Specifies the authentication method. <ul style="list-style-type: none"> <li>• By default, RSA signatures are used.               <ul style="list-style-type: none"> <li>• <b>rsa-sig</b>—RSA signatures require that you configure your peer routers to obtain certificates from a CA.</li> <li>• <b>rsa-encr</b>—RSA encrypted nonces require that you ensure each peer has the other peer's RSA public keys.</li> <li>• <b>pre-share</b>—Preshared keys require that you separately configure these preshared keys.</li> </ul> </li> </ul>
<b>Step 7</b>	<b>group {1   2   5   14   15   16   19   20   24}</b> <b>Example:</b> <code>Router(config-isakmp)# group 14</code>	Specifies the Diffie-Hellman (DH) group identifier. <ul style="list-style-type: none"> <li>• By default, DH group 1 is used.               <ul style="list-style-type: none"> <li>• <b>1</b>—768-bit DH (No longer recommended.)</li> <li>• <b>2</b>—1024-bit DH (No longer recommended)</li> <li>• <b>5</b>—1536-bit DH (No longer recommended)</li> <li>• <b>14</b>—Specifies the 2048-bit DH group.</li> </ul> </li> </ul>

	Command or Action	Purpose
		<ul style="list-style-type: none"> <li>• <b>15</b>—Specifies the 3072-bit DH group.</li> <li>• <b>16</b>—Specifies the 4096-bit DH group.</li> <li>• <b>19</b>—Specifies the 256-bit elliptic curve DH (ECDH) group.</li> <li>• <b>20</b>—Specifies the 384-bit ECDH group.</li> <li>• <b>24</b>—Specifies the 2048-bit DH/DSA group.</li> </ul> <p>The group chosen must be strong enough (have enough bits) to protect the IPsec keys during negotiation. A generally accepted guideline recommends the use of a 2048-bit group after 2013 (until 2030). Group 14 or higher (where possible) can be selected to meet this guideline. Even if a longer-lived security method is needed, the use of Elliptic Curve Cryptography is recommended, but group 15 and group 16 can also be considered.</p>
<b>Step 8</b>	<p><b>lifetime</b> <i>seconds</i></p> <p><b>Example:</b></p> <pre>Router(config-isakmp)# lifetime 180</pre>	<p>Specifies the lifetime of the IKE SA.</p> <ul style="list-style-type: none"> <li>• <i>seconds</i>—Time, in seconds, before each SA expires. Valid values: 60 to 86,400; default value: 86,400.</li> </ul> <p><b>Note</b> The shorter the lifetime (up to a point), the more secure your IKE negotiations will be. However, with longer lifetimes, future IPsec SAs can be set up more quickly.</p>
<b>Step 9</b>	<p><b>exit</b></p> <p><b>Example:</b></p> <pre>Router(config-isakmp)# exit</pre>	Exits config-isakmp configuration mode.
<b>Step 10</b>	<p><b>exit</b></p> <p><b>Example:</b></p> <pre>Router(config)# exit</pre>	Exits global configuration mode.
<b>Step 11</b>	<p><b>show crypto isakmp policy</b></p> <p><b>Example:</b></p> <pre>Router# show crypto isakmp policy</pre>	(Optional) Displays all existing IKE policies.
<b>Step 12</b>	Repeat these steps for each policy you want to create.	—

**Examples**

The following sample output from the **show crypto isakmp policy** command displays a warning message after a user tries to configure an IKE encryption method that the hardware does not support:

```
Router# show crypto isakmp policy
Protection suite of priority 1
    encryption algorithm: AES - Advanced Encryption Standard (256 bit keys).
```

```

WARNING:encryption hardware does not support the configured
encryption method for ISAKMP policy 1
  hash algorithm:      Secure Hash Standard 2 (256-bit)
  authentication method: Pre-Shared Key
  Diffie-Hellman group: #14 (2048 bit)
  lifetime:           3600 seconds, no volume limit

```

## Troubleshooting Tips

- Clear (and reinitialize) IPsec SAs by using the **clear crypto sa** EXEC command.

Using the **clear crypto sa** command without parameters will clear out the full SA database, which will clear out active security sessions. You may also specify the **peer**, **map**, or **entry** keywords to clear out only a subset of the SA database. For more information, see the **clear crypto sa** command in the Cisco IOS Security Command Reference.

- The default policy and default values for configured policies do not show up in the configuration when you issue the **show running-config** command. To display the default policy and any default values within configured policies, use the **show crypto isakmp policy** command.
- Any IPsec transforms or IKE encryption methods that the current hardware does not support should be disabled; they are ignored whenever an attempt to negotiate with the peer is made.

If a user enters an IPsec transform or an IKE encryption method that the hardware does not support, a warning message will be generated. These warning messages are also generated at boot time. When an encrypted card is inserted, the current configuration is scanned. If any IPsec transforms or IKE encryption methods are found that are not supported by the hardware, a warning message will be generated.

## What to Do Next

Depending on which authentication method you specified in your IKE policies (RSA signatures, RSA encrypted nonces, or preshared keys), you must do certain additional configuration tasks before IKE and IPsec can successfully use the IKE policies. For information on completing these additional tasks, refer to the [Configuring IKE Authentication, on page 14.](#)

To configure an AES-based transform set, see the module “Configuring Security for VPNs with IPsec.”

## Configuring IKE Authentication

After you have created at least one IKE policy in which you specified an authentication method (or accepted the default method), you need to configure an authentication method. IKE policies cannot be used by IPsec until the authentication method is successfully configured.



---

**Note** Before configuring IKE authentication, you must have configured at least one IKE policy, which is where the authentication method was specified (or RSA signatures was accepted by default).

---

To configure IKE authentication, you should perform one of the following tasks, as appropriate:



## Prerequisites

You must have configured at least one IKE policy, which is where the authentication method was specified (or RSA signatures was accepted by default).

## Configuring RSA Keys Manually for RSA Encrypted Nonces



**Note** This task can be performed only if a CA is not in use.

To manually configure RSA keys, perform this task for each IPsec peer that uses RSA encrypted nonces in an IKE policy.

### SUMMARY STEPS

1. **enable**
2. **configure terminal**
3. **crypto key generate rsa** {general-keys} | usage-keys} [label *key-label*] [exportable] [modulus *modulus-size*]
4. **crypto key generate ec** keysize [256 | 384] [label *label-string*]
5. **exit**
6. **show crypto key mypubkey rsa**
7. **configure terminal**
8. **crypto key pubkey-chain rsa**
9. Do one of the following:
  - **named-key** *key-name* [encryption | signature]
  - **addressed-key** *key-address* [encryption | signature]
10. **address** *ip-address*
11. **key-string** *key-string*
12. **quit**
13. Repeat these steps at each peer that uses RSA encrypted nonces in an IKE policy.
14. **exit**
15. **exit**
16. **show crypto key pubkey-chain rsa** [name *key-name* | address *key-address*]

### DETAILED STEPS

	Command or Action	Purpose
Step 1	<b>enable</b> <b>Example:</b> Router> enable	Enables privileged EXEC mode. <ul style="list-style-type: none"> <li>• Enter your password if prompted.</li> </ul>
Step 2	<b>configure terminal</b> <b>Example:</b> Router# configure terminal	Enters global configuration mode.

	Command or Action	Purpose
<b>Step 3</b>	<p><b>crypto key generate rsa</b> {general-keys}   usage-keys} [label <i>key-label</i>] [exportable] [modulus <i>modulus-size</i>]</p> <p><b>Example:</b></p> <pre>Router(config)# crypto key generate rsa general-keys modulus 360</pre>	<p>Generates RSA keys.</p> <ul style="list-style-type: none"> <li>If a <i>key-label</i> argument is not specified, the default value, which is the fully qualified domain name (FQDN) of the router, is used.</li> </ul>
<b>Step 4</b>	<p><b>crypto key generate ec</b> <b>keysize</b> [256   384] [label <i>label-string</i>]</p> <p><b>Example:</b></p> <pre>Router(config)# crypto key generate ec keysize 256 label Router_1_Key</pre>	<p>Generates EC keys.</p> <ul style="list-style-type: none"> <li>The 256 keyword specifies a 256-bit keysize.</li> <li>The 384 keyword specifies a 384-bit keysize.</li> <li>A label can be specified for the EC key by using the <b>label</b> keyword and <i>label-string</i> argument.</li> </ul> <p><b>Note</b> If a label is not specified, then FQDN value is used.</p>
<b>Step 5</b>	<p><b>exit</b></p> <p><b>Example:</b></p> <pre>Router(config)# exit</pre>	(Optional) Exits global configuration mode.
<b>Step 6</b>	<p><b>show crypto key mypubkey rsa</b></p> <p><b>Example:</b></p> <pre>Router# show crypto key mypubkey rsa</pre>	(Optional) Displays the generated RSA public keys.
<b>Step 7</b>	<p><b>configure terminal</b></p> <p><b>Example:</b></p> <pre>Router# configure terminal</pre>	Returns to global configuration mode.
<b>Step 8</b>	<p><b>crypto key pubkey-chain rsa</b></p> <p><b>Example:</b></p> <pre>Router(config)# crypto key pubkey-chain rsa</pre>	Enters public key chain configuration mode (so you can manually specify the RSA public keys of other devices).
<b>Step 9</b>	<p>Do one of the following:</p> <ul style="list-style-type: none"> <li><b>named-key</b> <i>key-name</i> [encryption   signature]</li> <li><b>addressed-key</b> <i>key-address</i> [encryption   signature]</li> </ul> <p><b>Example:</b></p> <pre>Router(config-pubkey-chain)# named-key otherpeer.example.com</pre> <p><b>Example:</b></p> <pre>Router(config-pubkey-chain)# addressed-key 10.1.1.2 encryption</pre>	<p>Indicates which remote peer's RSA public key you will specify and enters public key configuration mode.</p> <ul style="list-style-type: none"> <li>If the remote peer uses its hostname as its ISAKMP identity, use the <b>named-key</b> command and specify the remote peer's FQDN, such as <i>somerouter.example.com</i>, as the <i>key-name</i>.</li> <li>If the remote peer uses its IP address as its ISAKMP identity, use the <b>addressed-key</b> command and specify the remote peer's IP address as the <i>key-address</i>.</li> </ul>
<b>Step 10</b>	<p><b>address ip-address</b></p> <p><b>Example:</b></p>	<p>Specifies the IP address of the remote peer.</p> <ul style="list-style-type: none"> <li>If you use the <b>named-key</b> command, you need to use this command to specify the IP address of the peer.</li> </ul>

	Command or Action	Purpose
	Router(config-pubkey-key)# address 10.5.5.1	
<b>Step 11</b>	<p><b>key-string</b> key-string</p> <p><b>Example:</b></p> <pre>Router(config-pubkey-key)# key-string</pre> <p><b>Example:</b></p> <pre>Router(config-pubkey)# 00302017 4A7D385B 1234EF29 335FC973</pre> <p><b>Example:</b></p> <pre>Router(config-pubkey)# 2DD50A37 C4F4B0FD 9DADE748 429618D5</pre> <p><b>Example:</b></p> <pre>Router(config-pubkey)# 18242BA3 2EDFBDD3 4296142A DDF7D3D8</pre> <p><b>Example:</b></p> <pre>Router(config-pubkey)# 08407685 2F2190A0 0B43F1BD 9A8A26DB</pre> <p><b>Example:</b></p> <pre>Router(config-pubkey)# 07953829 791FCDE9 A98420F0 6A82045B</pre> <p><b>Example:</b></p> <pre>Router(config-pubkey)# 90288A26 DBC64468 7789F76E EE21</pre>	<p>Specifies the RSA public key of the remote peer.</p> <ul style="list-style-type: none"> <li>(This key was previously viewed by the administrator of the remote peer when the RSA keys of the remote router were generated.)</li> </ul>
<b>Step 12</b>	<p><b>quit</b></p> <p><b>Example:</b></p> <pre>Router(config-pubkey-key)# quit</pre>	Returns to public key chain configuration mode.
<b>Step 13</b>	Repeat these steps at each peer that uses RSA encrypted nonces in an IKE policy.	—
<b>Step 14</b>	<p><b>exit</b></p> <p><b>Example:</b></p> <pre>Router(config-pubkey-key)# exit</pre>	Returns to global configuration mode.
<b>Step 15</b>	<p><b>exit</b></p> <p><b>Example:</b></p> <pre>Router(config)# exit</pre>	Returns to privileged EXEC mode.
<b>Step 16</b>	<p><b>show crypto key pubkey-chain rsa</b> [<b>name</b> <i>key-name</i>   <b>address</b> <i>key-address</i>]</p> <p><b>Example:</b></p> <pre>Router# show crypto key pubkey-chain rsa</pre>	(Optional) Displays either a list of all RSA public keys that are stored on your router or details of a particular RSA key that is stored on your router.

## Configuring Preshared Keys

To configure preshared keys, perform these steps for each peer that uses preshared keys in an IKE policy.



- Note** Preshared keys do not scale well with a growing network. Mask preshared keys have the following restrictions:
- The SA cannot be established between the IPsec peers until all IPsec peers are configured for the same preshared key.
  - The mask preshared key must be distinctly different for remote users requiring varying levels of authorization. You must configure a new preshared key for each level of trust and assign the correct keys to the correct parties. Otherwise, an untrusted party may obtain access to protected data.

### SUMMARY STEPS

1. **enable**
2. **configure terminal**
3. **crypto isakmp identity {address | dn | hostname}**
4. **ip host hostname address1 [address2...address8]**
5. Do one of the following:
  - **crypto isakmp key keystring address peer-address [mask] [no-xauth]**
  - **crypto isakmp key keystring hostname hostname [no-xauth]**
6. Do one of the following:
  - **crypto isakmp key keystring address peer-address [mask] [no-xauth]**
  - **crypto isakmp key keystring hostname hostname [no-xauth]**
7. Repeat these steps at each peer that uses preshared keys in an IKE policy.

### DETAILED STEPS

	Command or Action	Purpose
<b>Step 1</b>	<b>enable</b> <b>Example:</b> Router> enable	Enables privileged EXEC mode. <ul style="list-style-type: none"> <li>• Enter your password if prompted.</li> </ul>
<b>Step 2</b>	<b>configure terminal</b> <b>Example:</b> Router# configure terminal	Enters global configuration mode.
<b>Step 3</b>	<b>crypto isakmp identity {address   dn   hostname}</b> <b>Example:</b> Router(config)# crypto isakmp identity address	Specifies the peer's ISAKMP identity by IP address, by distinguished name (DN) hostname at the local peer. <ul style="list-style-type: none"> <li>• <b>address</b>--Typically used when only one interface (and therefore only one IP address) will be used by the peer for IKE negotiations, and the IP address is known.</li> <li>• <b>dn</b>--Typically used if the DN of a router certificate is to be specified and chosen as the ISAKMP identity</li> </ul>

	Command or Action	Purpose
		<p>during IKE processing. The <code>dn</code> keyword is used only for certificate-based authentication.</p> <ul style="list-style-type: none"> <li>• <b>hostname</b>--Should be used if more than one interface on the peer might be used for IKE negotiations, or if the interface's IP address is unknown (such as with dynamically assigned IP addresses).</li> </ul>
<p><b>Step 4</b></p>	<p><b>ip host</b> <i>hostname address1</i> [<i>address2...address8</i>]</p> <p><b>Example:</b></p> <pre>Router(config)# ip host RemoteRouter.example.com 192.168.0.1</pre>	<p>If the local peer's ISAKMP identity was specified using a hostname, maps the peer's host name to its IP address(es) at all the remote peers.</p> <p>(This step might be unnecessary if the hostname or address is already mapped in a DNS server.)</p>
<p><b>Step 5</b></p>	<p>Do one of the following:</p> <ul style="list-style-type: none"> <li>• <b>crypto isakmp key</b> <i>keystring address peer-address</i> [<i>mask</i>] [<b>no-xauth</b>]</li> <li>• <b>crypto isakmp key</b> <i>keystring hostname hostname</i> [<b>no-xauth</b>]</li> </ul> <p><b>Example:</b></p> <pre>Router(config)# crypto isakmp key sharedkeystring address 192.168.1.33 no-xauth</pre> <p><b>Example:</b></p> <pre>Router(config) crypto isakmp key sharedkeystring hostname RemoteRouter.example.com</pre>	<p>Specifies at the local peer the shared key to be used with a particular remote peer.</p> <ul style="list-style-type: none"> <li>• If the remote peer specified its ISAKMP identity with an address, use the <b>address</b> keyword in this step; otherwise use the <b>hostname</b> keyword in this step.</li> <li>• <b>no-xauth</b>--Prevents the router from prompting the peer for Xauth information.</li> </ul> <p><b>Note</b> According to the design of preshared key authentication in IKE main mode, preshared keys must be based on the IP address of the peers. Although you can send a hostname as the identity of a preshared key authentication, the key is searched on the IP address of the peer; if the key is not found (based on the IP address) the negotiation will fail.</p>
<p><b>Step 6</b></p>	<p>Do one of the following:</p> <ul style="list-style-type: none"> <li>• <b>crypto isakmp key</b> <i>keystring address peer-address</i> [<i>mask</i>] [<b>no-xauth</b>]</li> <li>• <b>crypto isakmp key</b> <i>keystring hostname hostname</i> [<b>no-xauth</b>]</li> </ul> <p><b>Example:</b></p> <pre>Router(config) crypto isakmp key sharedkeystring address 10.0.0.1</pre> <p><b>Example:</b></p> <pre>Router(config) crypto isakmp key sharedkeystring hostname LocalRouter.example.com</pre>	<p>Specifies at the remote peer the shared key to be used with the local peer.</p> <ul style="list-style-type: none"> <li>• This is the same key you just specified at the local peer.</li> <li>• If the local peer specified its ISAKMP identity with an address, use the <b>address</b> keyword in this step; otherwise use the <b>hostname</b> keyword in this step.</li> </ul>
<p><b>Step 7</b></p>	<p>Repeat these steps at each peer that uses preshared keys in an IKE policy.</p>	<p>--</p>

## Configuring IKE Mode Configuration



**Note** IKE mode configuration has the following restrictions:

### SUMMARY STEPS

1. **enable**
2. **configure terminal**
3. **ip local pool** *pool-name start-addr end-addr*
4. **crypto isakmp client configuration address-pool local** *pool-name*

### DETAILED STEPS

	Command or Action	Purpose
<b>Step 1</b>	<b>enable</b> <b>Example:</b> Router> enable	Enables privileged EXEC mode. <ul style="list-style-type: none"><li>• Enter your password if prompted.</li></ul>
<b>Step 2</b>	<b>configure terminal</b> <b>Example:</b> Router# configure terminal	Enters global configuration mode.
<b>Step 3</b>	<b>ip local pool</b> <i>pool-name start-addr end-addr</i> <b>Example:</b> Router(config)# ip local pool pool1 172.16.23.0 172.16.23.255	Defines an existing local address pool that defines a set of addresses.
<b>Step 4</b>	<b>crypto isakmp client configuration address-pool local</b> <i>pool-name</i> <b>Example:</b> Router(config)# crypto isakmp client configuration address-pool local pool1	References the local address pool in the IKE configuration.

## Configuring an IKE Crypto Map for IPsec SA Negotiation



**Note** Security threats, as well as the cryptographic technologies to help protect against them, are constantly changing. For more information about the latest Cisco cryptographic recommendations, see the [Next Generation Encryption \(NGE\)](#) white paper.

### SUMMARY STEPS

1. **enable**

2. `configure terminal`
3. `crypto map tag sequence ipsec-isakmp`
4. `set pfs {group1 | group2 | group5 | group14 | group15 | group16}`

**DETAILED STEPS**

	Command or Action	Purpose
Step 1	<p><b>enable</b></p> <p><b>Example:</b></p> <pre>Router&gt; enable</pre>	<p>Enables privileged EXEC mode.</p> <ul style="list-style-type: none"> <li>• Enter your password if prompted.</li> </ul>
Step 2	<p><b>configure terminal</b></p> <p><b>Example:</b></p> <pre>Router# configure terminal</pre>	<p>Enters global configuration mode.</p>
Step 3	<p><b>crypto map tag sequence ipsec-isakmp</b></p> <p><b>Example:</b></p> <pre>Router(config)# crypto map example 1 ipsec-ipsec-isakmp</pre>	<p>Specifies the crypto map and enters crypto map configuration mode.</p> <ul style="list-style-type: none"> <li>• The <i>tag</i> argument specifies the crypto map.</li> <li>• The <i>sequence</i> argument specifies the sequence to insert into the crypto map entry.</li> <li>• The <b>ipsec-isakmp</b> keyword specifies IPsec with IKEv1 (ISAKMP).</li> </ul>
Step 4	<p><b>set pfs {group1   group2   group5   group14   group15   group16}</b></p> <p><b>Example:</b></p> <pre>Router(config-isakmp)# set pfs 14</pre>	<p>Specifies the DH group identifier for IPsec SA negotiation.</p> <ul style="list-style-type: none"> <li>• By default, DH group 1 is used.</li> <li>• <b>group1</b>—768-bit DH (No longer recommended)</li> <li>• <b>group2</b>—1024-bit DH (No longer recommended)</li> <li>• <b>group5</b>—1536-bit DH (No longer recommended)</li> <li>• <b>group14</b>—Specifies the 2048-bit DH group.</li> <li>• <b>group15</b>—Specifies the 3072-bit DH group.</li> <li>• <b>group16</b>—Specifies the 4096-bit DH group.</li> </ul> <p>The group chosen must be strong enough (have enough bits) to protect the IPsec keys during negotiation. A generally accepted guideline recommends the use of a 2048-bit group after 2013 (until 2030). Either group 14 can be selected to meet this guideline. Even if a longer-lived security method is needed, the use of Elliptic Curve Cryptography is recommended, but group 15 and group 16 can also be considered.</p>

# Configuration Examples for an IKE Configuration

## Example: Creating IKE Policies

This section contains the following examples, which show how to configure an AES IKE policy and a 3DES IKE policy.



### Note

Cisco no longer recommends using 3DES; instead, you should use AES. For more information about the latest Cisco cryptographic recommendations, see the [Next Generation Encryption \(NGE\)](#) white paper.

## Example: Creating 3DES IKE Policies

This example creates two IKE policies, with policy 15 as the highest priority, policy 20 as the next priority, and the existing default priority as the lowest priority. It also creates a preshared key to be used with policy 20 with the remote peer whose IP address is 192.168.224.33.

```
crypto isakmp policy 15
  encryption 3des
  hash md5
  authentication rsa-sig
  group 2
  lifetime 5000
!
crypto isakmp policy 20
  authentication pre-share
  lifetime 10000
!
crypto isakmp key 1234567890 address 192.168.224.33
```

In the example, the encryption DES of policy default would not appear in the written configuration because this is the default value for the encryption algorithm parameter.

If the **show crypto isakmp policy** command is issued with this configuration, the output is as follows:

```
Protection suite priority 15
encryption algorithm:3DES - Triple Data Encryption Standard (168 bit keys)
hash algorithm:Message Digest 5
authentication method:Rivest-Shamir-Adleman Signature
Diffie-Hellman group:#2 (1024 bit)
lifetime:5000 seconds, no volume limit
Protection suite priority 20
encryption algorithm:DES - Data Encryption Standard (56 bit keys)
hash algorithm:Secure Hash Standard
authentication method:preshared Key
Diffie-Hellman group:#1 (768 bit)
lifetime:10000 seconds, no volume limit
Default protection suite
encryption algorithm:DES - Data Encryption Standard (56 bit keys)
hash algorithm:Secure Hash Standard
authentication method:Rivest-Shamir-Adleman Signature
Diffie-Hellman group:#1 (768 bit)
lifetime:86400 seconds, no volume limit
```



Note that although the output shows “no volume limit” for the lifetimes, you can configure only a time lifetime (such as 86,400 seconds); volume-limit lifetimes are not configurable.

## Example: Creating an AES IKE Policy

The following example is sample output from the **show running-config** command. In this example, the AES 256-bit key is enabled.

```
Current configuration : 1665 bytes
!
version 12.2
service timestamps debug datetime msec
service timestamps log datetime msec
no service password-encryption
!
hostname "Router1"
!
!
ip subnet-zero
!
!
no ip domain lookup
!
ip audit notify log
ip audit po max-events 100
!
crypto isakmp policy 10
 encryption aes 256
 authentication pre-share
 lifetime 180
crypto isakmp key cisco123 address 10.0.110.1
!
!
crypto ipsec transform-set aasset esp-aes 256 esp-sha-hmac
 mode transport

.
.
.
```

## Example: Configuring IKE Authentication

The following example shows how to manually specify the RSA public keys of two IPsec peer-- the peer at 10.5.5.1 uses general-purpose keys, and the other peer uses special-usage keys:

```
crypto key pubkey-chain rsa
 named-key otherpeer.example.com
 address 10.5.5.1
 key-string
005C300D 06092A86 4886F70D 01010105
00034B00 30480241 00C5E23B 55D6AB22
04AEF1BA A54028A6 9ACC01C5 129D99E4
64CAB820 847EDAD9 DF0B4E4C 73A05DD2
BD62A8A9 FA603DD2 E2A8A6F8 98F76E28
D58AD221 B583D7A4 71020301 0001
quit
exit
addressed-key 10.1.1.2 encryption
key-string
```

```

00302017 4A7D385B 1234EF29 335FC973
2DD50A37 C4F4B0FD 9DADE748 429618D5
18242BA3 2EDFBDD3 4296142A DDF7D3D8
08407685 2F2190A0 0B43F1BD 9A8A26DB
07953829 791FCDE9 A98420F0 6A82045B
90288A26 DBC64468 7789F76E EE21
quit
exit
addressed-key 10.1.1.2 signature
key-string
0738BC7A 2BC3E9F0 679B00FE 53987BCC
01030201 42DD06AF E228D24C 458AD228
58BB5DDD F4836401 2A2D7163 219F882E
64CE69D4 B583748A 241BED0F 6E7F2F16
0DE0986E DF02031F 4B0B0912 F68200C4
C625C389 0BFF3321 A2598935 C1B1
quit
exit
exit

```

## Where to Go Next

After you have successfully configured IKE negotiation, you can begin configuring IPsec. For information on completing these tasks, see the module “Configuring Security for VPNs With IPsec.”

## Additional References

### Related Documents

Related Topic	Document Title
Cisco IOS commands	<a href="#">Cisco IOS Master Commands List, All Releases</a>
Security commands: complete command syntax, command mode, command history, defaults, usage guidelines, and examples	<ul style="list-style-type: none"> <li>• <a href="#">Cisco IOS Security Command Reference Commands A to C</a></li> <li>• <a href="#">Cisco IOS Security Command Reference Commands D to L</a></li> <li>• <a href="#">Cisco IOS Security Command Reference Commands M to R</a></li> <li>• <a href="#">Cisco IOS Security Command Reference Commands S to Z</a></li> </ul>
IPsec configuration	<a href="#">Configuring Security for VPNs with IPsec</a>
IKE Version 2	<a href="#">Configuring Internet Key Exchange Version 2 and FlexVPN</a>
Configuring RSA keys to obtain certificates from a CA	<a href="#">Deploying RSA Keys Within a PKI</a>

Related Topic	Document Title
Suite-B ESP transforms	<a href="#">Configuring Security for VPNs with IPsec</a>
Suite-B Integrity algorithm type transform configuration.	<a href="#">Configuring Internet Key Exchange Version 2 and FlexVPN</a>
Suite-B Elliptic curve Diffie-Hellman (ECDH) support for IPsec SA negotiation	<a href="#">Configuring Internet Key Exchange Version 2 and FlexVPN</a>
Suite-B support for certificate enrollment for a PKI	<a href="#">Configuring Certificate Enrollment for a PKI</a>
Recommended cryptographic algorithms	<a href="#">Next Generation Encryption</a>

**Standards**

Standards	Title
None	--

**MIBs**

MIBs	MIBs Link
None	To locate and download MIBs for selected platforms, Cisco IOS software releases, and feature sets, use Cisco MIB Locator found at the following URL:  <a href="http://www.cisco.com/go/mibs">http://www.cisco.com/go/mibs</a>

**RFCs**

RFCs	Title
RFC 2408	<a href="#">Internet Security Association and Key Management Protocol (ISAKMP)</a>
RFC 2409	The Internet Key Exchange (IKE)
RFC 2412	<a href="#">The OAKLEY Key Determination Protocol</a>

**Technical Assistance**

Description	Link
The Cisco Support and Documentation website provides online resources to download documentation, software, and tools. Use these resources to install and configure the software and to troubleshoot and resolve technical issues with Cisco products and technologies. Access to most tools on the Cisco Support and Documentation website requires a Cisco.com user ID and password.	<a href="http://www.cisco.com/cisco/web/support/index.html">http://www.cisco.com/cisco/web/support/index.html</a>

## Feature Information for Configuring IKE for IPsec VPNs

The following table provides release information about the feature or features described in this module. This table lists only the software release that introduced support for a given feature in a given software release train. Unless noted otherwise, subsequent releases of that software release train also support that feature.

Use Cisco Feature Navigator to find information about platform support and Cisco software image support. To access Cisco Feature Navigator, go to [www.cisco.com/go/cfn](http://www.cisco.com/go/cfn). An account on Cisco.com is not required.

**Table 1: Feature Information for Configuring IKE for IPsec VPNs**

Feature Name	Releases	Feature Information
Ability to Disable Extended Authentication for Static IPsec Peers	12.2(4)T	This feature allows a user to disable Xauth while configuring the preshared key for router-to-router IPsec. Thus, the router will not prompt the peer for a username and password, which are transmitted when Xauth occurs for VPN-client-to-Cisco-IOS IPsec.  The following command was modified by this feature: <b>crypto isakmp key.</b>
Advanced Encryption Standard (AES)	12.2(8)T	This feature adds support for the new encryption standard AES, which is a privacy transform for IPsec and IKE and has been developed to replace DES.  The following commands were modified by this feature: <b>crypto ipsec transform-set, encryption (IKE policy), show crypto ipsec transform-set, crypto ipsec transform-set, show crypto isakmp policy.</b>
SEAL Encryption	12.3(7)T	This feature adds support for SEAL encryption in IPsec.  The following command was modified by this feature: <b>crypto ipsec transform-set.</b>
Suite-B support in IOS SW crypto	15.1(2)T	Suite-B adds support in the Cisco IOS for the SHA-2 family (HMAC variant) hash algorithm used to authenticate packet data and verify the integrity verification mechanisms for the IKE protocol. HMAC is a variant that provides an additional level of hashing. This feature also adds elliptic curve Diffie-Hellman (ECDH) support for IPsec SA negotiation.  See the Configuring Security for VPNs with IPsec feature module for more detailed information about Cisco IOS Suite-B support.  The following command was modified by this feature: <b>authentication, crypto key generate ec keysize, crypto map, group, hash, set pfs.</b>



## CHAPTER 3

# Call Admission Control for IKE

---

The Call Admission Control for IKE feature describes the application of Call Admission Control (CAC) to the Internet Key Exchange (IKE) protocol in Cisco IOS software. CAC limits the number of simultaneous IKE and IPsec security associations (SAs) that is, calls to CAC that a router can establish.

- [Finding Feature Information, on page 27](#)
- [Prerequisites for Call Admission Control for IKE, on page 27](#)
- [Information About Call Admission Control for IKE, on page 27](#)
- [How to Configure Call Admission Control for IKE, on page 29](#)
- [Configuration Examples for Call Admission Control for IKE, on page 32](#)
- [Additional References, on page 33](#)
- [Feature Information for Call Admission Control for IKE, on page 34](#)

## Finding Feature Information

Your software release may not support all the features documented in this module. For the latest caveats and feature information, see [Bug Search Tool](#) and the release notes for your platform and software release. To find information about the features documented in this module, and to see a list of the releases in which each feature is supported, see the feature information table.

Use Cisco Feature Navigator to find information about platform support and Cisco software image support. To access Cisco Feature Navigator, go to <https://cfng.cisco.com/>. An account on Cisco.com is not required.

## Prerequisites for Call Admission Control for IKE

- Configure IKE on the device.

## Information About Call Admission Control for IKE

### IKE Session

There are two ways to limit the number of Internet Key Exchange (IKE) security associations (SAs) that a device can establish to or from another device:

- Configure the absolute IKE SA limit by entering the **crypto call admission limit** command. The device drops new IKE SA requests when the configured limit is reached.
- Configure the system resource limit by entering the **call admission limit** command. The device drops new IKE SA requests when the level of system resources that are configured in the unit of charge is being used.

Call Admission Control (CAC) is applied only to new SAs (that is, when an SA does not already exist between peers). Every effort is made to preserve existing SAs. New SA requests are denied due to a lack of system resources or because the configured IKE SA limit is reached.

## Security Association Limit

An SA is a description of how two or more entities will utilize security services to communicate securely on behalf of a particular data flow. IKE requires and uses SAs to identify the parameters of its connections. IKE can negotiate and establish its own SA. An IKE SA is used by IKE only, and it is bidirectional. An IKE SA cannot limit IPsec.

IKE drops SA requests based on a user-configured SA limit. To configure an IKE SA limit, enter the **crypto call admission limit** command. When there is a new SA request from a peer router, IKE determines whether the number of active IKE SAs plus the number of SAs being negotiated meets or exceeds the configured SA limit. If the number is greater than or equal to the limit, the new SA request is rejected and a syslog is generated. This log contains the source destination IP address of the SA request.

The **ipsec sa number** and **ike sa number** keyword and argument pairs in the **crypto call admission limit** command set the limit for the number of established IPsec SAs and IKE SAs.

## Limit on Number of In-Negotiation IKE Connections

You can limit the number of in-negotiation IKE connections that can be configured on a device based on your Cisco release. This type of IKE connection represents either an aggressive mode IKE SA or a main mode IKE SA prior to its authentication and actual establishment. The default value for maximum in-negotiation CAC for IKEv2 is 40.

You can use the **crypto call admission limit ike in-negotiation-sa number** command to specify the maximum number of Internet Key Exchange (IKE) and IPsec security associations (SAs) that the device can establish before IKE begins rejecting the new SA requests.

The **all in-negotiation-sa number** and **ike in-negotiation-sa number** keyword and argument pairs in the **crypto call admission limit** command limit all SAs in negotiation and IKE SAs in negotiation.

## System Resource Usage

CAC polls a global resource monitor so that IKE knows when the router is running short of CPU cycles or memory buffers. You can configure a limit, in the range 1 to 100000, that represents the level of system resource usage in system resource usage units. When that level of resources is being used, IKE drops (will not accept new) SA requests. To configure the system resource usage limit, enter the **call admission limit** command.

For each incoming new SA request, the current load on the router is converted into a numerical value, representing the system resource usage level, and is compared to the resource limit set by the **call admission**

**limit** command. If the current load is more than the configured resource limit, IKE drops the new SA request. Load on the router includes active SAs, CPU usage, and SA requests being considered.

The **call admission load** command configures a multiplier value from 0 to 1000 that represents a scaling factor for current system resource usage and a load metric poll rate of 1 to 32 seconds. The numerical value for the system resource usage level is calculated by the formula (scaling factor \* current system resource usage) / 100. It is recommended that the **call admission load** command not be used unless advised by a Cisco Technical Assistance Center (TAC) engineer.

# How to Configure Call Admission Control for IKE

## Configuring the IKE Security Association Limit

Perform this task to configure the absolute IKE SA limit. The router drops new IKE SA requests when the limit has been reached.

### SUMMARY STEPS

1. **enable**
2. **configure terminal**
3. **crypto call admission limit** {all in-negotiation-sa number | ipsec sa number | ike {in-negotiation-sa number | sa number}}
4. **exit**

### DETAILED STEPS

	Command or Action	Purpose
Step 1	<b>enable</b> <b>Example:</b>  Router> enable	Enables privileged EXEC mode.  • Enter your password if prompted.
Step 2	<b>configure terminal</b> <b>Example:</b>  Router# configure terminal	Enters global configuration mode.
Step 3	<b>crypto call admission limit</b> {all in-negotiation-sa number   ipsec sa number   ike {in-negotiation-sa number   sa number}} <b>Example:</b>  Router(config)# crypto call admission limit ike sa 25	Specifies the maximum number of IKE SAs or total SAs in negotiation or the maximum IKE SAs or IPsec SAs that can be established before IKE begins rejecting new SA requests. The recommended CAC value for IKEv1 is 40.
Step 4	<b>exit</b> <b>Example:</b>	Exits global configuration mode and returns to privileged EXEC mode.

	Command or Action	Purpose
	Router(config)# exit	

## Configuring the IKEv2 Security Association Limit

Perform this task to configure the absolute IKEv2 SA limit. The router drops new IKE SA requests when the limit has been reached.

### SUMMARY STEPS

1. enable
2. configure terminal
3. crypto ikev2 limit {max-in-negotiation-sa limit *number* | max-sa limit *number*}
4. exit

### DETAILED STEPS

	Command or Action	Purpose
<b>Step 1</b>	<b>enable</b> <b>Example:</b> Router> enable	Enables privileged EXEC mode. <ul style="list-style-type: none"> <li>• Enter your password if prompted.</li> </ul>
<b>Step 2</b>	<b>configure terminal</b> <b>Example:</b> Router# configure terminal	Enters global configuration mode.
<b>Step 3</b>	<b>crypto ikev2 limit {max-in-negotiation-sa limit <i>number</i>   max-sa limit <i>number</i>}</b> <b>Example:</b> Router(config)# crypto ikev2 limit max-in-negotiation-sa 5000	Enables call admission control as follows: <ul style="list-style-type: none"> <li>• max-in-negotiation-sa limit: Limits the total number of in-negotiation IKEv2 SAs on the node.</li> <li>• max-sa limit: Limits the total number of IKEv2 SAs on the node.</li> </ul>
<b>Step 4</b>	<b>exit</b> <b>Example:</b> Router(config)# exit	Exits global configuration mode and returns to privileged EXEC mode.

## Configuring the System Resource Limit

Perform this task to configure the system resource limit. The router drops new IKE SA requests when the level of system resources that are configured in the unit of charge is being used.



**SUMMARY STEPS**

1. `enable`
2. `configure terminal`
3. `call admission limit charge`
4. `exit`

**DETAILED STEPS**

	<b>Command or Action</b>	<b>Purpose</b>
<b>Step 1</b>	<b>enable</b> <b>Example:</b> <pre>Router&gt; enable</pre>	Enables privileged EXEC mode. <ul style="list-style-type: none"> <li>• Enter your password if prompted.</li> </ul>
<b>Step 2</b>	<b>configure terminal</b> <b>Example:</b> <pre>Router# configure terminal</pre>	Enters global configuration mode.
<b>Step 3</b>	<b>call admission limit charge</b> <b>Example:</b> <pre>Router(config)# call admission limit 1000</pre>	Sets the level of the system resources that, when used, causes IKE to stop accepting new SA requests. <ul style="list-style-type: none"> <li>• <i>charge</i> --Valid values are 1 to 100000.</li> </ul>
<b>Step 4</b>	<b>exit</b> <b>Example:</b> <pre>Router(config)# exit</pre>	Exits global configuration mode and returns to privileged EXEC mode.

**Verifying the Call Admission Control for IKE Configuration**

To verify the CAC for IKE configuration, perform the following steps.

**SUMMARY STEPS**

1. `show call admission statistics`
2. `show crypto call admission statistics`

**DETAILED STEPS****Step 1** `show call admission statistics`

Use this command to monitor the global CAC configuration parameters and the behavior of CAC.

**Example:**

```
Router# show call admission statistics
Total Call admission charges: 82, limit 1000
```

Total calls rejected 1430, accepted 0  
Load metric: charge 82, unscaled 82%

## Step 2 show crypto call admission statistics

Use this command to monitor crypto CAC statistics.

### Example:

```
Router# show crypto call admission statistics
-----
Crypto Call Admission Control Statistics
-----
System Resource Limit:      111 Max IKE SAs:      0 Max in nego: 1000
Total IKE SA Count:        0 active:          0 negotiating:  0
Incoming IKE Requests:     0 accepted:      0 rejected:     0
Outgoing IKE Requests:     0 accepted:      0 rejected:     0
Rejected IKE Requests:     0 rsrc low:      0 Active SA limit: 0
                                           In-neg SA limit: 0

IKE packets dropped at dispatch:      0
Max IPSEC SAs:      111
Total IPSEC SA Count:      0 active:          0 negotiating:  0
Incoming IPSEC Requests:   0 accepted:      0 rejected:     0
Outgoing IPSEC Requests:   0 accepted:      0 rejected:     0
Phase1.5 SAs under negotiation:      0
```

# Configuration Examples for Call Admission Control for IKE

## Example Configuring the IKE Security Association Limit

The following example shows how to specify a maximum limit of 25 SAs before IKE starts rejecting new SA requests:

```
Router(config)# crypto call admission limit ike sa 25
```

## Example Configuring the System Resource Limit

The following example shows how to specify that IKE should drop SA requests when the level of system resources that are configured in the unit of charge reaches 9000:

```
Router(config)# call admission limit 9000
```

# Additional References

## Related Documents

Related Topic	Document Title
Cisco IOS commands	<a href="#">Cisco IOS Master Commands List, All Releases</a>
Configuring IKE	Configuring Internet Key Exchange for IPsec VPNs
IKE commands	<i>Cisco IOS Security Command Reference</i>

## Standards

Standards	Title
None	--

## MIBs

MIBs	MIBs Link
None	To locate and download MIBs for selected platforms, Cisco software releases, and feature sets, use Cisco MIB Locator found at the following URL: <a href="http://www.cisco.com/go/mibs">http://www.cisco.com/go/mibs</a>

## RFCs

RFCs	Title
RFC 2409	<i>The Internet Key Exchange</i>

## Technical Assistance

Description	Link
The Cisco Support and Documentation website provides online resources to download documentation, software, and tools. Use these resources to install and configure the software and to troubleshoot and resolve technical issues with Cisco products and technologies. Access to most tools on the Cisco Support and Documentation website requires a Cisco.com user ID and password.	<a href="http://www.cisco.com/cisco/web/support/index.html">http://www.cisco.com/cisco/web/support/index.html</a>

## Feature Information for Call Admission Control for IKE

The following table provides release information about the feature or features described in this module. This table lists only the software release that introduced support for a given feature in a given software release train. Unless noted otherwise, subsequent releases of that software release train also support that feature.

Use Cisco Feature Navigator to find information about platform support and Cisco software image support. To access Cisco Feature Navigator, go to [www.cisco.com/go/cfn](http://www.cisco.com/go/cfn). An account on Cisco.com is not required.

**Table 2: Feature Information for Call Admission Control for IKE**

Feature Name	Releases	Feature Information
Call Admission Control for IKE	12.3(8)T 12.2(18)SXD1 12.4(6)T 12.2(33)SRA 12.2(33)SXH	<p>The Call Admission Control for IKE feature describes the application of Call Admission Control (CAC) to the Internet Key Exchange (IKE) protocol in Cisco IOS software.</p> <p>In Cisco IOS Release 12.3(8)T, this feature was introduced.</p> <p>This feature was integrated into Cisco IOS Release 12.2(18)SXD1 and implemented on the Cisco 6500 and Cisco 7600 routers.</p> <p>In Cisco IOS Release 12.4(6)T, the ability to configure a limit on the number of in-negotiation IKE connections was added.</p> <p>The following sections provide information about this feature:</p> <p>The following commands were introduced or modified: <b>call admission limit</b>, <b>clear crypto call admission statistics</b>, <b>crypto call admission limit</b>, <b>show call admission statistics</b>, <b>show crypto call admission statistics</b>.</p>
IKEv1 Hardening	15.1(3)T	<p>The IKEv1 hardening feature describes the enhancements made to the Call Admission Control (CAC) for IKE feature.</p> <p>In Cisco IOS Release 15.1(3)T, this feature was introduced.</p> <p>The following sections provide information about this feature:</p> <p>The following commands were introduced or modified: <b>crypto call admission limit</b>, <b>show crypto call admission statistics</b>.</p>



## CHAPTER 4

# Certificate to ISAKMP Profile Mapping

The Certificate to ISAKMP Profile Mapping feature enables you to assign an Internet Security Association and Key Management Protocol (ISAKMP) profile to a peer on the basis of the contents of arbitrary fields in the certificate. In addition, this feature allows you to assign a group name to those peers that are assigned an ISAKMP profile.

- [Finding Feature Information, on page 35](#)
- [Prerequisites for Certificate to ISAKMP Profile Mapping, on page 35](#)
- [Restrictions for Certificate to ISAKMP Profile Mapping, on page 36](#)
- [Information About Certificate to ISAKMP Profile Mapping, on page 36](#)
- [How to Configure Certificate to ISAKMP Profile Mapping, on page 37](#)
- [Configuration Examples for Certificate to ISAKMP Profile Mapping, on page 40](#)
- [Additional References, on page 43](#)
- [Feature Information for Certificate to ISAKMP Profile Mapping, on page 44](#)

## Finding Feature Information

Your software release may not support all the features documented in this module. For the latest caveats and feature information, see [Bug Search Tool](#) and the release notes for your platform and software release. To find information about the features documented in this module, and to see a list of the releases in which each feature is supported, see the feature information table.

Use Cisco Feature Navigator to find information about platform support and Cisco software image support. To access Cisco Feature Navigator, go to <https://cfng.cisco.com/>. An account on Cisco.com is not required.

## Prerequisites for Certificate to ISAKMP Profile Mapping

- You should be familiar with configuring certificate maps.
- You should be familiar with configuring ISAKMP profiles.

## Restrictions for Certificate to ISAKMP Profile Mapping

This feature is not applicable if you use Rivest, Shamir, and Adelman (RSA)-signature or RSA-encryption authentication without certificate exchange. ISAKMP peers must be configured for RSA-signature or RSA-encryption authentication using certificates.

IPsec with two trustpoints enrolled in the same Certificate Authority (CA) server is not supported. When there are two or more ISAKMP profiles, each having a different trustpoint enrolled in the same CA server, the responder selects the last global trustpoint. (Trustpoints are selected in the reverse order in which they are defined globally). For the IPsec tunnel establishment to be successful for peers, the trustpoint selected by the initiator should match the trustpoint selected by the responder. All other IPsec tunnels will fail to establish connection if the trustpoints do not match.

## Information About Certificate to ISAKMP Profile Mapping

### Certificate to ISAKMP Profile Mapping Overview

Prior to Cisco IOS Release 12.3(8)T, the only way to map a peer to an ISAKMP profile was as follows. The ISAKMP identity field in the ISAKMP exchange was used for mapping a peer to an ISAKMP profile. When certificates were used for authentication, the ISAKMP identity payload contained the subject name from the certificate. If a CA did not provide the required group value in the first Organizational Unit (OU) field of a certificate, an ISAKMP profile could not be assigned to a peer.

Effective with Cisco IOS Release 12.3(8)T, a peer can still be mapped as explained above. However, the Certificate to ISAKMP Profile Mapping feature enables you to assign an ISAKMP profile to a peer on the basis of the contents of arbitrary fields in the certificate. You are no longer limited to assigning an ISAKMP profile on the basis of the subject name of the certificate. In addition, this feature allows you to assign a group to a peer to which an ISAKMP profile has been assigned.

### How Certificate to ISAKMP Profile Mapping Works

The figure below illustrates how certificate maps may be attached to ISAKMP profiles and assigned group names.

Figure 1: Certificate Maps Mapped for Profile Group Assignment

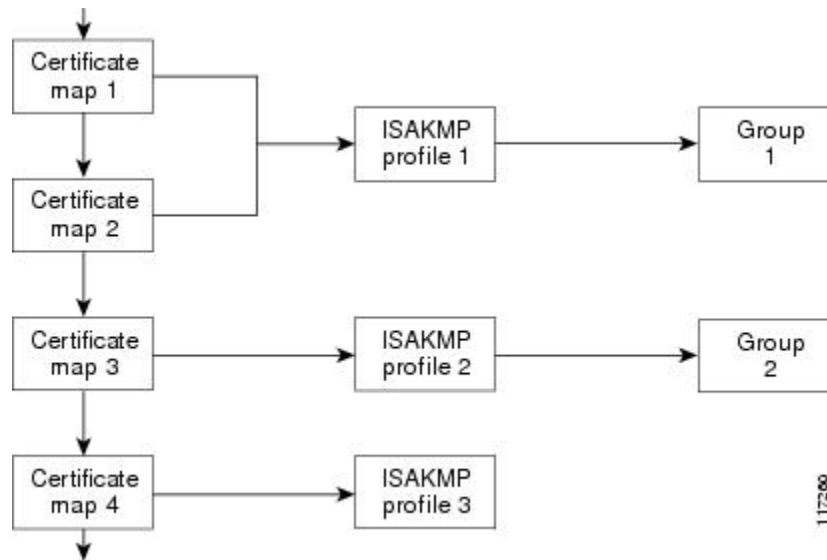

A certificate map can be attached to only one ISAKMP profile although an ISAKMP profile can have several certificate maps attached to it.

Certificate maps provide the ability for a certificate to be matched with a given set of criteria. ISAKMP profiles can bind themselves to certificate maps, and if the presented certificate matches the certificate map present in an ISAKMP profile, the peer will be assigned the ISAKMP profile. If the ISAKMP profile contains a client configuration group name, the same group name will be assigned to the peer. This ISAKMP profile information will override the information in the ID\_KEY\_ID identity or in the first OU field of the certificate.

## Assigning an ISAKMP Profile and Group Name to a Peer

To assign an ISAKMP profile to a peer on the basis of arbitrary fields in the certificate, use the **match certificate** command after the ISAKMP profile has been defined.

To associate a group name with an ISAKMP profile that will be assigned to a peer, use the **client configuration group** command, also after the ISAKMP profile has been defined.

## How to Configure Certificate to ISAKMP Profile Mapping

### Mapping the Certificate to the ISAKMP Profile

To map the certificate to the ISAKMP profile, perform the following steps. This configuration will enable you to assign the ISAKMP profile to a peer on the basis of the contents of arbitrary fields in the certificate.

#### SUMMARY STEPS

1. **enable**
2. **configure terminal**
3. **crypto isakmp profile** *profile-name*

#### 4. match certificate *certificate-map*

##### DETAILED STEPS

	Command or Action	Purpose
<b>Step 1</b>	<b>enable</b> <b>Example:</b> Router# enable	Enables privileged EXEC mode. <ul style="list-style-type: none"> <li>• Enter your password if prompted.</li> </ul>
<b>Step 2</b>	<b>configure terminal</b> <b>Example:</b> Router# configure terminal	Enters global configuration mode.
<b>Step 3</b>	<b>crypto isakmp profile <i>profile-name</i></b> <b>Example:</b> Router (config)# crypto isakmp profile vpnprofile	Defines an ISAKMP profile and enters into crypto ISAKMP profile configuration mode.
<b>Step 4</b>	<b>match certificate <i>certificate-map</i></b> <b>Example:</b> Router (conf-isa-prof)# match certificate map1	Accepts the name of a certificate map.

## Verifying That the Certificate Has Been Mapped

The following **show** command may be used to verify that the subject name of the certificate map has been properly configured.

##### SUMMARY STEPS

1. enable
2. show crypto ca certificates

##### DETAILED STEPS

	Command or Action	Purpose
<b>Step 1</b>	<b>enable</b> <b>Example:</b> Router# enable	Enables privileged EXEC mode. <ul style="list-style-type: none"> <li>• Enter your password if prompted.</li> </ul>
<b>Step 2</b>	<b>show crypto ca certificates</b> <b>Example:</b> Router# show crypto ca certificates	Displays information about your certificate.



## Assigning the Group Name to the Peer

To associate a group name with a peer when the peer is mapped to an ISAKMP profile, perform the following steps.

### SUMMARY STEPS

1. **enable**
2. **configure terminal**
3. **crypto isakmp profile** *profile-name*
4. **client configuration group** *group-name*

### DETAILED STEPS

	Command or Action	Purpose
Step 1	<b>enable</b> <b>Example:</b> Router# enable	Enables privileged EXEC mode. <ul style="list-style-type: none"> <li>• Enter your password if prompted.</li> </ul>
Step 2	<b>configure terminal</b> <b>Example:</b> Router# configure terminal	Enters global configuration mode.
Step 3	<b>crypto isakmp profile</b> <i>profile-name</i> <b>Example:</b> Router (config)# crypto isakmp profile vpnprofile	Defines an ISAKMP profile and enters into isakmp profile configuration mode.
Step 4	<b>client configuration group</b> <i>group-name</i> <b>Example:</b> Router (conf-isa-prof)# client configuration group group1	Accepts the name of a group that will be assigned to a peer when the peer is assigned this crypto ISAKMP profile.

## Monitoring and Maintaining Your Certificate to ISAKMP Profile Mapping

To monitor and maintain your certificate to ISAKMP profile mapping, you may use the following **debug** command.

### SUMMARY STEPS

1. **enable**
2. **debug crypto isakmp**

## DETAILED STEPS

	Command or Action	Purpose
<b>Step 1</b>	<b>enable</b> <b>Example:</b> Router# enable	Enables privileged EXEC mode. <ul style="list-style-type: none"> <li>• Enter your password if prompted.</li> </ul>
<b>Step 2</b>	<b>debug crypto isakmp</b> <b>Example:</b> Router# debug crypto isakmp	Displays output showing that the certificate has gone through certificate map matching and that the certificate matches the ISAKMP profile.  The command may also be used to verify that the peer has been assigned a group.

## Configuration Examples for Certificate to ISAKMP Profile Mapping

### Certificates Mapped to the ISAKMP Profile on the Basis of Arbitrary Fields Example

The following configuration example shows that whenever a certificate contains “ou = green,” the ISAKMP profile “cert\_pro” will be assigned to the peer:

```
crypto pki certificate map cert_map 10
  subject-name co ou = green
  !
  !
crypto isakmp identity dn
crypto isakmp profile cert_pro
  ca trust-point 2315
  ca trust-point LaBCA
  initiate mode aggressive
  match certificate cert_map
```

### Group Name Assigned to a Peer That Is Associated with an ISAKMP Profile Example

The following example shows that the group “some\_group” is to be associated with a peer that has been assigned an ISAKMP profile:

```
crypto isakmp profile id_profile
  ca trust-point 2315
  match identity host domain cisco.com
  client configuration group some_group
```

## Mapping a Certificate to an ISAKMP Profile Verification Example

The following examples show that a certificate has been mapped to an ISAKMP profile. The examples include the configurations for the responder and initiator, **show command** output verifying that the subject name of the certificate map has been configured, and **debug** command output showing that the certificate has gone through certificate map matching and been matched to the ISAKMP profile.

### Responder Configuration

```
crypto pki certificate map cert_map 10
! The above line is the certificate map definition.
  subject-name co ou = green
! The above line shows that the subject name must have "ou = green."
!
crypto isakmp profile certpro
! The above line shows that this is the ISAKMP profile that will match if the certificate
of the peer matches cert_map (shown on third line below).
  ca trust-point 2315
  ca trust-point LaBcA
  match certificate cert_map
  initiate mode aggressive
```

### Initiator Configuration

```
crypto ca trustpoint LaBcA
  enrollment url http://10.76.82.20:80/cgi-bin/openscep
  subject-name ou=green,c=IN
! The above line ensures that the subject name "ou = green" is set.
  revocation-check none
```

### show crypto ca certificates Command Output for the Initiator

```
Router# show crypto ca certificates
Certificate
  Status: Available
  Certificate Serial Number: 21
  Certificate Usage: General Purpose
  Issuer:
    cn=blue-lab CA
    o=CISCO
    c=IN
  Subject:
    Name: Router1.cisco.com
    c=IN
    ou=green
! The above line is a double check that "ou = green" has been set as the subject name.
  hostname=Router1.cisco.com
  Validity Date:
    start date: 14:34:30 UTC Mar 31 2004
    end   date: 14:34:30 UTC Apr 1 2009
    renew date: 00:00:00 UTC Jan 1 1970
  Associated Trustpoints: LaBcA
```

### debug crypto isakmp Command Output for the Responder

```
Router# debug crypto isakmp
6d23h: ISAKMP (0:268435460): received packet from 192.0.0.2 dport 500 sport 500 Global (R)
```

```

MM_KEY_EXCH
6d23h: ISAKMP: Main Mode packet contents (flags 1, len 892):
6d23h:         ID payload
6d23h:         FQDN <Router1.cisco.com> port 500 protocol 17
6d23h:         CERT payload
6d23h:         SIG payload
6d23h:         KEEPALIVE payload
6d23h:         NOTIFY payload
6d23h: ISAKMP:(0:4:HW:2):Input = IKE_MESG_FROM_PEER, IKE_MM_EXCH
6d23h: ISAKMP:(0:4:HW:2):Old State = IKE_R_MM4 New State = IKE_R_MM5
6d23h: ISAKMP:(0:4:HW:2): processing ID payload. message ID = 0
6d23h: ISAKMP (0:268435460): ID payload
        next-payload : 6
        type       : 2
        FQDN name   : Router1.cisco.com
        protocol    : 17
        port        : 500
        length      : 28
6d23h: ISAKMP:(0:4:HW:2):: peer matches *none* of the profiles
6d23h: ISAKMP:(0:4:HW:2): processing CERT payload. message ID = 0
6d23h: ISAKMP:(0:4:HW:2): processing a CT_X509_SIGNATURE cert
6d23h: ISAKMP:(0:4:HW:2): peer's pubkey isn't cached
6d23h: ISAKMP:(0:4:HW:2): OU = green
6d23h: ISAKMP:(0:4:HW:2): certificate map matches certpro profile
! The above line shows that the certificate has gone through certificate map matching and
that it matches the "certpro" profile.
6d23h: ISAKMP:(0:4:HW:2): Trying to re-validate CERT using new profile
6d23h: ISAKMP:(0:4:HW:2): Creating CERT validation list: 2315, LaBcA,
6d23h: ISAKMP:(0:4:HW:2): CERT validity confirmed.

```

## Group Name Assigned to a Peer Verification Example

The following configuration and debug output show that a group has been assigned to a peer.

### Initiator Configuration

```

crypto isakmp profile certpro
  ca trust-point 2315
  ca trust-point LaBcA
  match certificate cert_map
  client configuration group new_group
! The statement on the above line will assign the group "new_group" to any peer that matches
the ISAKMP profile "certpro."
  initiate mode aggressive
!

```

### debug crypto isakmp profile Command Output for the Responder

The following debug output example shows that the peer has been matched to the ISAKMP profile named "certpro" and that it has been assigned a group named "new\_group."

```

Router# debug crypto isakmp profile
6d23h: ISAKMP (0:268435461): received packet from 192.0.0.2 dport 500 sport 500 Global (R)
MM_KEY_EXCH
6d23h: ISAKMP: Main Mode packet contents (flags 1, len 892):
6d23h:         ID payload
6d23h:         FQDN <Router1.cisco.com> port 500 protocol 17
6d23h:         CERT payload
6d23h:         SIG payload

```

```

6d23h:          KEEPALIVE payload
6d23h:          NOTIFY payload
6d23h: ISAKMP:(0:5:HW:2):Input = IKE_MSG_FROM_PEER, IKE_MM_EXCH
6d23h: ISAKMP:(0:5:HW:2):Old State = IKE_R_MM4 New State = IKE_R_MM5
6d23h: ISAKMP:(0:5:HW:2): processing ID payload. message ID = 0
6d23h: ISAKMP (0:268435461): ID payload
      next-payload : 6
      type          : 2
      FQDN name     : Router1.cisco.com
      protocol      : 17
      port          : 500
      length        : 28
6d23h: ISAKMP:(0:5:HW:2):: peer matches *none* of the profiles
6d23h: ISAKMP:(0:5:HW:2): processing CERT payload. message ID = 0
6d23h: ISAKMP:(0:5:HW:2): processing a CT_X509_SIGNATURE cert
6d23h: ISAKMP:(0:5:HW:2): peer's pubkey isn't cached
6d23h: ISAKMP:(0:5:HW:2): OU = green
6d23h: ISAKMP:(0:5:HW:2): certificate map matches certpro profile
6d23h: ISAKMP:(0:5:HW:2): Trying to re-validate CERT using new profile
6d23h: ISAKMP:(0:5:HW:2): Creating CERT validation list: 2315, LaBcA,
6d23h: ISAKMP:(0:5:HW:2): CERT validity confirmed.
6d23h: ISAKMP:(0:5:HW:2):Profile has no keyring, aborting key search
6d23h: ISAKMP:(0:5:HW:2): Profile certpro assigned peer the group named new_group

```

## Additional References

### Related Documents

Related Topic	Document Title
Configuring ISAKMP profiles	VRF-Aware IPsec
Security commands	<i>Cisco IOS Security Command Reference</i>

### Standards

Standards	Title
None	--

### MIBs

MIBs	MIBs Link
None	To locate and download MIBs for selected platforms, Cisco IOS software releases, and feature sets, use Cisco MIB Locator found at the following URL: <a href="http://www.cisco.com/go/mibs">http://www.cisco.com/go/mibs</a>

### RFCs

RFC	Title
None	--

**Technical Assistance**

Description	Link
<p>The Cisco Support website provides extensive online resources, including documentation and tools for troubleshooting and resolving technical issues with Cisco products and technologies.</p> <p>To receive security and technical information about your products, you can subscribe to various services, such as the Product Alert Tool (accessed from Field Notices), the Cisco Technical Services Newsletter, and Really Simple Syndication (RSS) Feeds.</p> <p>Access to most tools on the Cisco Support website requires a Cisco.com user ID and password.</p>	<p><a href="http://www.cisco.com/cisco/web/support/index.html">http://www.cisco.com/cisco/web/support/index.html</a></p>

## Feature Information for Certificate to ISAKMP Profile Mapping

The following table provides release information about the feature or features described in this module. This table lists only the software release that introduced support for a given feature in a given software release train. Unless noted otherwise, subsequent releases of that software release train also support that feature.

Use Cisco Feature Navigator to find information about platform support and Cisco software image support. To access Cisco Feature Navigator, go to [www.cisco.com/go/cfn](http://www.cisco.com/go/cfn). An account on Cisco.com is not required.

**Table 3: Feature Information for Certificate to ISAKMP Profile Mapping**

Feature Name	Releases	Feature Information
Certificate to ISAKMP Profile Mapping	12.3(8)T 12.2(33)SRA 12.2(33)SXH	<p>The Certificate to ISAKMP Profile Mapping feature enables you to assign an Internet Security Association and Key Management Protocol (ISAKMP) profile to a peer on the basis of the contents of arbitrary fields in the certificate. In addition, this feature allows you to assign a group name to those peers that are assigned an ISAKMP profile.</p> <p>This feature was introduced in the Cisco IOS Release 12.3(8)T</p> <p>This feature was integrated into Cisco IOS Release 12.2(33)SRA.</p> <p>This feature was integrated into Cisco IOS Release 12.2(33)SXH.</p>



## CHAPTER 5

# Encrypted Preshared Key

---

The Encrypted Preshared Key feature allows you to securely store plain text passwords in type 6 (encrypted) format in NVRAM.

- [Finding Feature Information](#), on page 45
- [Restrictions for Encrypted Preshared Key](#), on page 45
- [Information About Encrypted Preshared Key](#), on page 46
- [How to Configure an Encrypted Preshared Key](#), on page 47
- [Configuration Examples for Encrypted Preshared Key](#), on page 55
- [Where to Go Next](#), on page 56
- [Additional References](#), on page 57

## Finding Feature Information

Your software release may not support all the features documented in this module. For the latest caveats and feature information, see [Bug Search Tool](#) and the release notes for your platform and software release. To find information about the features documented in this module, and to see a list of the releases in which each feature is supported, see the feature information table.

Use Cisco Feature Navigator to find information about platform support and Cisco software image support. To access Cisco Feature Navigator, go to <https://cfngng.cisco.com/>. An account on Cisco.com is not required.

## Restrictions for Encrypted Preshared Key

- Old ROM monitors (ROMMONs) and boot images cannot recognize the new type 6 passwords. Therefore, errors are expected if you boot from an old ROMMON.
- For Cisco 836 routers, please note that support for Advanced Encryption Standard (AES) is available only on IP plus images.

# Information About Encrypted Preshared Key

## Using the Encrypted Preshared Key Feature to Securely Store Passwords

Using the Encrypted Preshared Key feature, you can securely store plain text passwords in type 6 format in NVRAM using a command-line interface (CLI). Type 6 passwords are encrypted. Although the encrypted passwords can be seen or retrieved, it is difficult to decrypt them to find out the actual password. Use the **key config-key** command with the **password encryption aes** command to configure and enable the password (symmetric cipher AES is used to encrypt the keys). The password (key) configured using the **key config-key password-encryption** command is the master encryption key that is used to encrypt all other keys in the router.

If you configure the **password encryption aes** command without configuring the **key config-key** command, the following message is printed at startup or during any nonvolatile generation (NVGEN) process, such as when the **show running-config** or **copy running-config startup-config** commands have been configured:

```
"Can not encrypt password. Please configure a configuration-key with 'key config-key'"
```

### Changing a Password

If the password (master key) is changed, or reencrypted, using the **key config-key password-encryption** command, the list registry passes the old key and the new key to the application modules that are using type 6 encryption.

### Deleting a Password

If the master key that was configured using the **key config-key password-encryption** command is deleted from the system, a warning is printed (and a confirm prompt is issued) that states that all type 6 passwords will become useless. As a security measure, after the passwords have been encrypted, they will never be decrypted in the software. However, passwords can be reencrypted as explained in the previous paragraph.



#### Caution

If the password configured using the **key config-key password-encryption** command is lost, it cannot be recovered. The password should be stored in a safe location.

### Unconfiguring Password Encryption

If you later unconfigure password encryption using the **no password encryption aes** command, all existing type 6 passwords are left unchanged, and as long as the password (master key) that was configured using the **key config-key password-encryption** command exists, the type 6 passwords will be decrypted as and when required by the application.

### Storing Passwords

Because no one can “read” the password (configured using the **key config-key password-encryption** command), there is no way that the password can be retrieved from the router. Existing management stations cannot “know” what it is unless the stations are enhanced to include this key somewhere, in which case the password needs to be stored securely within the management system. If configurations are stored using TFTP, the



configurations are not standalone, meaning that they cannot be loaded onto a router. Before or after the configurations are loaded onto a router, the password must be manually added (using the **key config-key password-encryption** command). The password can be manually added to the stored configuration but is not recommended because adding the password manually allows anyone to decrypt all passwords in that configuration.

## Configuring New or Unknown Passwords

If you enter or cut and paste cipher text that does not match the master key, or if there is no master key, the cipher text is accepted or saved, but an alert message is printed. The alert message is as follows:

```
"ciphertext>[for username bar] is incompatible with the configured master key."
```

If a new master key is configured, all the plain keys are encrypted and made type 6 keys. The existing type 6 keys are not encrypted. The existing type 6 keys are left as is.

If the old master key is lost or unknown, you have the option of deleting the master key using the **no key config-key password-encryption** command. Deleting the master key using the **no key config-key password-encryption** command causes the existing encrypted passwords to remain encrypted in the router configuration. The passwords will not be decrypted.

## Enabling the Encrypted Preshared Key

The **password encryption aes** command is used to enable the encrypted password.

# How to Configure an Encrypted Preshared Key

## Configuring an Encrypted Preshared Key

To configure an encrypted preshared key, perform the following steps.

### SUMMARY STEPS

1. **enable**
2. **configure terminal**
3. **key config-key password-encryption** *[text]*
4. **password encryption aes**

### DETAILED STEPS

	Command or Action	Purpose
Step 1	<b>enable</b> <b>Example:</b> Router> enable	Enables privileged EXEC mode. <ul style="list-style-type: none"> <li>• Enter your password if prompted.</li> </ul>
Step 2	<b>configure terminal</b> <b>Example:</b>	Enters global configuration mode.

	Command or Action	Purpose
	<code>Router# configure terminal</code>	
<b>Step 3</b>	<p><b>key config-key password-encryption</b> <i>[text]</i></p> <p><b>Example:</b></p> <pre>Router (config)# key config-key password-encryption</pre>	<p>Stores a type 6 encryption key in private NVRAM.</p> <ul style="list-style-type: none"> <li>• If you want to key in interactively (using the enter key) and an encrypted key already exists, you will be prompted for the following: Old key, New key, and Confirm key.</li> <li>• If you want to key in interactively but an encryption key is not present, you will be prompted for the following: New key and Confirm key.</li> <li>• If you want to remove the password that is already encrypted, you will see the following prompt: “WARNING: All type 6 encrypted keys will become unusable. Continue with master key deletion? [yes/no]:”.</li> </ul>
<b>Step 4</b>	<p><b>password encryption aes</b></p> <p><b>Example:</b></p> <pre>Router (config)# password-encryption aes</pre>	Enables the encrypted preshared key.

## Troubleshooting Tips

If you see the warning message “ciphertext >[for username bar>] is incompatible with the configured master key,” you have entered or cut and pasted cipher text that does not match the master key or there is no master key. (The cipher text will be accepted or saved.) The warning message will allow you to locate the broken configuration line or lines.

## Monitoring Encrypted Preshared Keys

To get logging output for encrypted preshared keys, perform the following steps.

1. **enable**
2. **password logging**

### SUMMARY STEPS

1. **enable**
2. **password logging**

### DETAILED STEPS

	Command or Action	Purpose
<b>Step 1</b>	<code>enable</code>	Enables privileged EXEC mode.

	Command or Action	Purpose
	<b>Example:</b> Router> enable	<ul style="list-style-type: none"> <li>Enter your password if prompted.</li> </ul>
<b>Step 2</b>	<b>password logging</b> <b>Example:</b> Router# password logging	Provides a log of debugging output for a type 6 password operation.

### Examples

The following **password logging** debug output shows that a new master key has been configured and that the keys have been encrypted with the new master key:

```
Router (config)# key config-key password-encrypt
New key:
Confirm key:
Router (config)#
01:40:57: TYPE6_PASS: New Master key configured, encrypting the keys with
the new master keypas
Router (config)# key config-key password-encrypt
Old key:
New key:
Confirm key:
Router (config)#
01:42:11: TYPE6_PASS: Master key change heralded, re-encrypting the keys
with the new master key
01:42:11: TYPE6_PASS: Mac verification successful
01:42:11: TYPE6_PASS: Mac verification successful
01:42:11: TYPE6_PASS: Mac verification successful
```

## What To Do Next

You can perform any of the following procedures. Each procedure is independent of the others.

## Configuring an ISAKMP Preshared Key

To configure an ISAKMP preshared key, perform the following procedure.

### SUMMARY STEPS

1. **enable**
2. **configure terminal**
3. **crypto isakmp key** *keystring* **address** *peer-address*
4. **crypto isakmp key** *keystring* **hostname** *hostname*

## DETAILED STEPS

	Command or Action	Purpose
<b>Step 1</b>	<b>enable</b> <b>Example:</b> <pre>Router# enable</pre>	Enables privileged EXEC mode. <ul style="list-style-type: none"> <li>• Enter your password if prompted.</li> </ul>
<b>Step 2</b>	<b>configure terminal</b> <b>Example:</b> <pre>Router# configure terminal</pre>	Enters global configuration mode.
<b>Step 3</b>	<b>crypto isakmp key <i>keystring</i> address <i>peer-address</i></b> <b>Example:</b> <pre>Router (config)# crypto isakmp key cisco address 10.2.3.4</pre>	Configures a preshared authentication key. <ul style="list-style-type: none"> <li>• The <i>peer-address</i> argument specifies the IP address of the remote peer.</li> </ul>
<b>Step 4</b>	<b>crypto isakmp key <i>keystring</i> hostname <i>hostname</i></b> <b>Example:</b> <pre>Router (config)# crypto isakmp key mykey hostname mydomain.com</pre>	Configures a preshared authentication key. <ul style="list-style-type: none"> <li>• The <i>hostname</i> argument specifies the fully qualified domain name (FQDN) of the peer.</li> </ul>

**Example**

The following sample output shows that an encrypted preshared key has been configured:

```
crypto isakmp key 6 _Hg[^^ECgLGGPF^RXTQfDDWQ][YAAB address 10.2.3.4
crypto isakmp key 6 `eR\eTRaKCUZPYQfDgXRwi_AAB hostname mydomain.com
```

## Configuring an ISAKMP Preshared Key in ISAKMP Keyrings

To configure an ISAKMP preshared key in ISAKMP keyrings, which are used in IPsec Virtual Route Forwarding (VRF) configurations, perform the following procedure.

## SUMMARY STEPS

1. **enable**
2. **configure terminal**
3. **crypto keyring *keyring-name***
4. **pre-shared-key address *address* key *key***
5. **pre-shared-key hostname *hostname* key *key***

## DETAILED STEPS

	Command or Action	Purpose
Step 1	<b>enable</b> <b>Example:</b> Router# enable	Enables privileged EXEC mode. <ul style="list-style-type: none"> <li>• Enter your password if prompted.</li> </ul>
Step 2	<b>configure terminal</b> <b>Example:</b> Router# configure terminal	Enters global configuration mode.
Step 3	<b>crypto keyring</b> <i>keyring-name</i> <b>Example:</b> Router (config)# crypto keyring mykeyring	Defines a crypto keyring to be used during Internet Key Exchange (IKE) authentication and enters keyring configuration mode.
Step 4	<b>pre-shared-key address</b> <i>address</i> <b>key</b> <i>key</i> <b>Example:</b> Router (config-keyring)# pre-shared-key address 10.2.3.5 key cisco	Defines a preshared key to be used for IKE authentication. <ul style="list-style-type: none"> <li>• The <i>address</i> argument specifies the IP address of the remote peer.</li> </ul>
Step 5	<b>pre-shared-key hostname</b> <i>hostname</i> <b>key</b> <i>key</i> <b>Example:</b> Router (config-keyring)# pre-shared-key hostname mydomain.com key cisco	Defines a preshared key to be used for IKE authentication. <ul style="list-style-type: none"> <li>• The <i>hostname</i> argument specifies the FQDN of the peer.</li> </ul>

**Example**

The following **show-running-config** sample output shows that an encrypted preshared key in ISAKMP keyrings has been configured.

```
crypto keyring mykeyring
pre-shared-key address 10.2.3.5 key 6 `WHCJYR_Z]GRPF^RXTQfDcfZ]GPAAB
pre-shared-key hostname mydomain.com key 6 aE_REHDcOfYCPF^RXTQfDJYVVNSAAB
```

## Configuring ISAKMP Aggressive Mode

To configure ISAKMP aggressive mode, perform the following steps.

## SUMMARY STEPS

1. **enable**
2. **configure terminal**
3. **crypto isakmp peer** *ip-address* *ip-address*

4. **set aggressive-mode client-endpoint** *client-endpoint*
5. **set aggressive-mode password** *password*

## DETAILED STEPS

	Command or Action	Purpose
<b>Step 1</b>	<b>enable</b> <b>Example:</b> Router# enable	Enables privileged EXEC mode. <ul style="list-style-type: none"> <li>• Enter your password if prompted.</li> </ul>
<b>Step 2</b>	<b>configure terminal</b> <b>Example:</b> Router# configure terminal	Enters global configuration mode.
<b>Step 3</b>	<b>crypto isakmp peer ip-address</b> <i>ip-address</i> <b>Example:</b> Router (config)# crypto isakmp peer ip-address 10.2.3.4	To enable an IP Security (IPSec) peer for IKE querying of authentication, authorization, and accounting (AAA) for tunnel attributes in aggressive mode and to enter ISAKMP peer configuration mode.
<b>Step 4</b>	<b>set aggressive-mode client-endpoint</b> <i>client-endpoint</i> <b>Example:</b> Router (config-isakmp-peer)# set aggressive-mode client-endpoint fqdn cisco.com	Specifies the Tunnel-Client-Endpoint attribute within an ISAKMP peer configuration.
<b>Step 5</b>	<b>set aggressive-mode password</b> <i>password</i> <b>Example:</b> Router (config-isakmp-peer)# set aggressive-mode password cisco	Specifies the Tunnel-Password attribute within an ISAKMP peer configuration.

### Example

The following **show-running-config** sample output shows that an encrypted preshared key in ISAKMP aggressive mode has been configured.

```
crypto isakmp peer address 10.2.3.4
  set aggressive-mode password 6 ^aKPIQ_KJE_PPF^RXTQfDTIaLNeAAB
  set aggressive-mode client-endpoint fqdn cisco.com
```

## Configuring a Unity Server Group Policy

To configure a unity server group policy, perform the following steps.

## SUMMARY STEPS

1. **enable**
2. **configure terminal**
3. **crypto isakmp client configuration group** *group-name*
4. **pool** *name*
5. **domain name**
6. **key** *name*

## DETAILED STEPS

	Command or Action	Purpose
<b>Step 1</b>	<b>enable</b> <b>Example:</b> Router# enable	Enables privileged EXEC mode. <ul style="list-style-type: none"> <li>• Enter your password if prompted.</li> </ul>
<b>Step 2</b>	<b>configure terminal</b> <b>Example:</b> Router# configure terminal	Enters global configuration mode.
<b>Step 3</b>	<b>crypto isakmp client configuration group</b> <i>group-name</i> <b>Example:</b> Router (config)# crypto isakmp client configuration group mygroup	Specifies the policy profile of the group that will be defined and enters ISAKMP group configuration mode.
<b>Step 4</b>	<b>pool</b> <i>name</i> <b>Example:</b> Router (config-isakmp-group)# pool mypool	Defines a local pool address.
<b>Step 5</b>	<b>domain name</b> <b>Example:</b> Router (config-isakmp-group)# domain cisco.com	Specifies the Domain Name Service (DNS) domain to which a group belongs.
<b>Step 6</b>	<b>key</b> <i>name</i> <b>Example:</b> Router (config-isakmp-group)# key cisco	Specifies the IKE preshared key for group policy attribute definition.

**Example**

The following **show-running-config** sample output shows that an encrypted key has been configured for a unity server group policy:

```
crypto isakmp client configuration group mygroup
  key 6 cZZgDZPOE\ddPF^RXTQfDTIaLNeAAB
  domain cisco.com
  pool mypool
```

## Configuring an Easy VPN Client

To configure an Easy VPN client, perform the following steps.

### SUMMARY STEPS

1. **enable**
2. **configure terminal**
3. **crypto ipsec client ezvpn *name***
4. **peer *ipaddress***
5. **mode client**
6. **group *group-name* key *group-key***
7. **connect manual**

### DETAILED STEPS

	Command or Action	Purpose
<b>Step 1</b>	<b>enable</b> <b>Example:</b> Router# enable	Enables privileged EXEC mode. <ul style="list-style-type: none"> <li>• Enter your password if prompted.</li> </ul>
<b>Step 2</b>	<b>configure terminal</b> <b>Example:</b> Router# configure terminal	Enters global configuration mode.
<b>Step 3</b>	<b>crypto ipsec client ezvpn <i>name</i></b> <b>Example:</b> Router (config)# crypto ipsec client ezvpn myclient	Creates a Cisco Easy VPN remote configuration and enters Cisco Easy VPN remote configuration mode.
<b>Step 4</b>	<b>peer <i>ipaddress</i></b> <b>Example:</b> Router (config-isakmp-peer)# peer 10.2.3.4	Sets the peer IP address for the VPN connection.
<b>Step 5</b>	<b>mode client</b> <b>Example:</b> Router (config-isakmp-epvy)# mode client	Automatically configures the router for Cisco Easy VPN Client mode operation, which uses Network Address Translation (NAT) or Peer Address Translation (PAT) address translations.



	Command or Action	Purpose
Step 6	<b>group</b> <i>group-name</i> <b>key</b> <i>group-key</i> <b>Example:</b> Router (config-isakmp-ezvpn)# group mygroup key cisco	Specifies the group name and key value for the VPN connection.
Step 7	<b>connect manual</b> <b>Example:</b> Router (config-isakmp-ezvpn)# connect manual	Specifies the manual setting for directing the Cisco Easy VPN remote client to wait for a command or application program interface (API) call before attempting to establish the Cisco Easy VPN remote connection.

### Example

The following **show-running-config** sample output shows that an Easy VPN client has been configured. The key has been encrypted.

```
crypto ipsec client ezvpn myclient
connect manual
group mygroup key 6 gdMI`S^[GicPF^RXTQfDFKEO\RAAB
mode client
peer 10.2.3.4
```

## Configuration Examples for Encrypted Preshared Key

### Encrypted Preshared Key Example

The following is an example of a configuration for which a type 6 preshared key has been encrypted. It includes the prompts and messages that a user might see.

```
Router (config)# crypto isakmp key cisco address 10.0.0.2
Router (config)# exit
Router# show running-config | include crypto isakmp key
crypto isakmp key cisco address 10.0.0.2
Router#
Router# configure terminal
Enter configuration commands, one per line. End with CNTL/Z.
Router (config)# password encryption aes

Router (config)# key config-key password-encrypt

New key:
Confirm key:
Router (config)#
01:46:40: TYPE6_PASS: New Master key configured, encrypting the keys with
the new master key
Router (config)# exit
Router # show running-config | include crypto isakmp key
crypto isakmp key 6 CXWdhVTZYB_Vcd^`cIHDOahiFTa address 10.0.0.2
```

## No Previous Key Present Example

In the following configuration example, no previous key is present:

```
Router (config)#
```

## Key Already Exists Example

In the following configuration example, a key already exists:

```
Router (config)#
Old key:
Router (config)#
```

## Key Already Exists But the User Wants to Key In Interactively Example

In the following configuration example, the user wants to key in interactively, but a key already exists. The Old key, New key, and Confirm key prompts will show on your screen if you enter the **key config-key** command and press the enter key to get into interactive mode.

```
Router (config)#
Old key:
New key:
Confirm key:
```

## No Key Present But the User Wants to Key In Interactively Example

In the following example, the user wants to key in interactively, but no key is present. The New key and Confirm key prompts will show on your screen if you are in interactive mode.

```
Router (config)#

New key:
Confirm key:
```

## Removal of the Password Encryption Example

In the following configuration example, the user wants to remove the encrypted password. The “WARNING: All type 6 encrypted keys will become unusable. Continue with master key deletion? [yes/no]:” prompt will show on your screen if you are in interactive mode.

```
Router (config)#
WARNING: All type 6 encrypted keys will become unusable. Continue with master key deletion
? [yes/no]: y
```

## Where to Go Next

Configure any other preshared keys.

# Additional References

## Related Documents

Related Topic	Document Title
Configuring passwords	<i>Cisco IOS Security Command Reference</i>

## Standards

Standards	Title
None	--

## MIBs

MIBs	MIBs Link
None	To locate and download MIBs for selected platforms, Cisco IOS software releases, and feature sets, use Cisco MIB Locator found at the following URL: <a href="http://www.cisco.com/go/mibs">http://www.cisco.com/go/mibs</a>

## RFCs

RFCs	Title
None	--

## Technical Assistance

Description	Link
The Cisco Support and Documentation website provides online resources to download documentation, software, and tools. Use these resources to install and configure the software and to troubleshoot and resolve technical issues with Cisco products and technologies. Access to most tools on the Cisco Support and Documentation website requires a Cisco.com user ID and password.	<a href="http://www.cisco.com/cisco/web/support/index.html">http://www.cisco.com/cisco/web/support/index.html</a>





## CHAPTER 6

# Distinguished Name Based Crypto Maps

### Feature History

Release	Modification
12.2(4)T	This feature was introduced.



**Note** Security threats, as well as the cryptographic technologies to help protect against them, are constantly changing. For more information about the latest Cisco cryptographic recommendations, see the [Next Generation Encryption](#) (NGE) white paper.

This feature module describes the Distinguished Name Based Crypto Map feature in Cisco IOS Release 12.2(4)T. It includes the following sections:

- [Finding Feature Information](#), on page 59
- [Feature Overview](#), on page 60
- [Supported Platforms](#), on page 60
- [Supported Standards MIBs and RFCs](#), on page 61
- [Prerequisites](#), on page 61
- [Configuration Tasks](#), on page 62
- [Configuration Examples](#), on page 64

## Finding Feature Information

Your software release may not support all the features documented in this module. For the latest caveats and feature information, see [Bug Search Tool](#) and the release notes for your platform and software release. To find information about the features documented in this module, and to see a list of the releases in which each feature is supported, see the feature information table.

Use Cisco Feature Navigator to find information about platform support and Cisco software image support. To access Cisco Feature Navigator, go to <https://cfng.cisco.com/>. An account on Cisco.com is not required.

# Feature Overview

The Distinguished Name Based Crypto Maps feature allows you to configure the router to restrict access to selected encrypted interfaces for those peers with specific certificates, especially certificates with particular Distinguished Names (DNs).

Previously, if the router accepted a certificate or a shared secret from the encrypting peer, Cisco IOS did not have a method of preventing the peer from communicating with any encrypted interface other than the restrictions on the IP address of the encrypting peer. This feature allows you to configure which crypto maps are usable to a peer based on the DN that a peer used to authenticate itself, thereby, enabling you to control which encrypted interfaces a peer with a specified DN can access.

## Benefits

The Distinguished Name Based Crypto Maps feature allows you to set restrictions in the router configuration that prevent peers with specific certificates--especially certificates with particular DNs-- from having access to selected encrypted interfaces.

## Restrictions

### System Requirements

To configure this feature, your router must support IP Security.

### Performance Impact

If you restrict access to a large number of DNs, it is recommended that you specify a few number of crypto maps referring to large identity sections instead of specifying a large number of crypto maps referring to small identity sections.

## Related Documents

The following documents provide information related to the Distinguished Name Based Crypto Maps feature:

- Cisco IOS Security Command Reference
- Cisco IOS Security Configuration Guide: Secure Connectivity, Release 12.4T
- [Next Generation Encryption](#) (NGE) white paper.

## Supported Platforms

This feature is supported on the following platforms:

- Cisco 1700 series
- Cisco 2600 series
- Cisco 3620

- Cisco 3640
- Cisco 3660
- Cisco 7100 series
- Cisco 7200 series
- Cisco uBR905 Cable Access Router
- Cisco uBR925 Cable Access Router

### Determining Platform Support Through Feature Navigator

Use Cisco Feature Navigator to find information about platform support and Cisco software image support. To access Cisco Feature Navigator, go to [www.cisco.com/go/cfn](http://www.cisco.com/go/cfn). An account on Cisco.com is not required.

## Supported Standards MIBs and RFCs

### Standards

None

### MIBs

None

To locate and download MIBs for selected platforms, Cisco IOS releases, and feature sets, use Cisco MIB Locator found at the following URL:

<http://www.cisco.com/go/mibs>

### RFCs

None

## Prerequisites

Before configuring a DN based crypto map, you must perform the following tasks:

- Create an Internet Key Exchange (IKE) policy at each peer.

For more information on creating IKE policies, refer to the “Configuring Internet Key Exchange for IPsec VPNs” chapter in the *Cisco IOS Security Configuration Guide: Secure Connectivity ..*

- Create crypto map entries for IPsec.

For more information on creating crypto map entries, refer to the “Configuring Security for VPNs with IPsec” chapter in the *Cisco IOS Security Configuration Guide: Secure Connectivity*

## Configuration Tasks

See the following sections for configuration tasks for the Distinguished Name Based Crypto Maps feature. Each task in the list is identified as either required or optional.

- [Configuring DN Based Crypto Maps \(authenticated by DN\), on page 62](#) (required)
- [Configuring DN Based Crypto Maps \(authenticated by hostname\), on page 62](#) (required)
- [Applying Identity to DN Based Crypto Maps, on page 63](#) (required)
- [Verifying DN Based Crypto Maps, on page 63](#) (optional)

### Configuring DN Based Crypto Maps (authenticated by DN)

To configure a DN based crypto map that can be used only by peers that have been authenticated by a DN, use the following commands beginning in global configuration mode:

#### SUMMARY STEPS

1. Router(config)# **crypto identity** *name*
2. Router(crypto-identity)# **dn** *name=string* [*,name=string*]

#### DETAILED STEPS

	Command or Action	Purpose
<b>Step 1</b>	Router(config)# <b>crypto identity</b> <i>name</i>	Configures the identity of a router with the given list of DNs in the certificate of the router and enters crypto identity configuration mode.
<b>Step 2</b>	Router(crypto-identity)# <b>dn</b> <i>name=string</i> [ <i>,name=string</i> ]	Associates the identity of the router with the DN in the certificate of the router.  <b>Note</b> The identity of the peer must match the identity in the exchanged certificate.

### Configuring DN Based Crypto Maps (authenticated by hostname)

To configure a DN based crypto map that can be used only by peers that have been authenticated by a hostname, use the following commands beginning in global configuration mode:

#### SUMMARY STEPS

1. Router(config)# **crypto identity** *name*
2. Router(crypto-identity)# **fqdn** *name*



## DETAILED STEPS

	Command or Action	Purpose
Step 1	Router(config)# <b>crypto identity</b> <i>name</i>	Configures the identity of a router with the given list of DNs in the certificate of the router and enters crypto identity configuration mode.
Step 2	Router(crypto-identity)# <b>fqdn</b> <i>name</i>	Associates the identity of the router with the hostname that the peer used to authenticate itself.  <b>Note</b> The identity of the peer must match the identity in the exchanged certificate.

## Applying Identity to DN Based Crypto Maps

To apply the identity (within the crypto map context), use the following commands beginning in global configuration mode:

## SUMMARY STEPS

1. Router(config)# **crypto map** *map-name seq-num ipsec-isakmp*
2. Router(config-crypto-map)# **identity** *name*

## DETAILED STEPS

	Command or Action	Purpose
Step 1	Router(config)# <b>crypto map</b> <i>map-name seq-num ipsec-isakmp</i>	Creates or modifies a crypto map entry and enters the crypto map configuration mode.
Step 2	Router(config-crypto-map)# <b>identity</b> <i>name</i>	Applies the identity to the crypto map.  When this command is applied, only the hosts that match a configuration listed within the <b>identity</b> <i>name</i> can use the specified crypto map.  <b>Note</b> If the <b>identity</b> command does not appear within the crypto map, the encrypted connection does not have any restrictions other than the IP address of the encrypting peer.

## Verifying DN Based Crypto Maps

To verify that this functionality is properly configured, use the following command in EXEC mode:

Command	Purpose
Router# <b>show crypto identity</b>	Displays the configured identities.

## Troubleshooting Tips

If an encrypting peer attempts to establish a connection that is blocked by the DN based crypto map configuration, the following error message will be logged:

```
<time>: %CRYPTO-4-IKE_QUICKMODE_BAD_CERT: encrypted connection attempted with a peer without
the configured certificate attributes.
```

## Configuration Examples

### DN Based Crypto Map Configuration Example

The following example shows how to configure DN based crypto maps that have been authenticated by DN and hostname. Comments are included inline to explain various commands.

```
! DN based crypto maps require you to configure an IKE policy at each peer.
crypto isakmp policy 15
  encryption aes
  hash sha
  authentication rsa-sig
  group 14
  lifetime 5000
crypto isakmp policy 20
  encryption aes
  hash sha
  authentication pre-share
  group 14
  lifetime 10000
crypto isakmp key 1234567890 address 171.69.224.33
!
! The following is an IPsec crypto map (part of IPsec configuration). It can be used only
! by peers that have been authenticated by DN and if the certificate belongs to BigBiz.
crypto map map-to-bigbiz 10 ipsec-isakmp
  set peer 172.21.114.196
  set transform-set my-transformset
  match address 124
  identity to-bigbiz
!
crypto identity to-bigbiz
  dn ou=BigBiz
!
!
! This crypto map can be used only by peers that have been authenticated by hostname
! and if the certificate belongs to little.com.
crypto map map-to-little-com 10 ipsec-isakmp
  set peer 172.21.115.119
  set transform-set my-transformset
  match address 125
  identity to-little-com
!
crypto identity to-little-com
  fqdn little.com
!
```



## CHAPTER 7

# IPsec and Quality of Service

The IPsec and Quality of Service feature allows Cisco IOS quality of service (QoS) policies to be applied to IP Security (IPsec) packet flows on the basis of a QoS group that can be added to the current Internet Security Association and Key Management Protocol (ISAKMP) profile.



**Note** Security threats, as well as the cryptographic technologies to help protect against them, are constantly changing. For more information about the latest Cisco cryptographic recommendations, see the [Next Generation Encryption](#) (NGE) white paper.

### Finding Support Information for Platforms and Cisco IOS Software Images

Use Cisco Feature Navigator to find information about platform support and Cisco IOS software image support. Access Cisco Feature Navigator at <http://tools.cisco.com/ITDIT/CFN/jsp/index.jsp>. You must have an account on Cisco.com. If you do not have an account or have forgotten your username or password, click **Cancel** at the login dialog box and follow the instructions that appear.

- [Finding Feature Information](#), on page 65
- [Prerequisites for IPsec and Quality of Service](#), on page 66
- [Restrictions for IPsec and Quality of Service](#), on page 66
- [Information About IPsec and Quality of Service](#), on page 66
- [How to Configure IPsec and Quality of Service](#), on page 66
- [Configuration Examples for IPsec and Quality of Service](#), on page 68
- [Additional References](#), on page 71
- [Feature Information for IPsec and Quality of Service](#), on page 72

## Finding Feature Information

Your software release may not support all the features documented in this module. For the latest caveats and feature information, see [Bug Search Tool](#) and the release notes for your platform and software release. To find information about the features documented in this module, and to see a list of the releases in which each feature is supported, see the feature information table.

Use Cisco Feature Navigator to find information about platform support and Cisco software image support. To access Cisco Feature Navigator, go to <https://cfng.cisco.com/>. An account on Cisco.com is not required.

## Prerequisites for IPsec and Quality of Service

- You should be familiar with IPsec and the concept of ISAKMP profiles.
- You should be familiar with Cisco IOS QoS.

## Restrictions for IPsec and Quality of Service

- This feature can be applied only via the ISAKMP profile. The limit of 128 QoS groups that exists for QoS applications applies to this feature as well.
- You can apply an IPsec QoS group only to outbound service policies.
- QoS is not supported for software encryption.

## Information About IPsec and Quality of Service

### IPsec and Quality of Service Overview

The IPsec and Quality of Service feature allows you to apply QoS policies, such as traffic policing and shaping, to IPsec-protected packets by adding a QoS group to ISAKMP profiles. After the QoS group has been added, this group value will be mapped to the same QoS group as defined in QoS class maps. Any current QoS method that makes use of this QoS group tag can be applied to IPsec packet flows. Common groupings of packet flows can have specific policy classes applied by having the IPsec QoS group made available to the QoS mechanism. Marking IPsec flows allows QoS mechanisms to be applied to classes of traffic that could provide support for such things as restricting the amount of bandwidth that is available to specific groups or devices or marking the type of service (ToS) bits on certain flows.

The application of the QoS group is applied at the ISAKMP profile level because it is the profile that can uniquely identify devices through its concept of match identity criteria. These criteria are on the basis of the Internet Key Exchange (IKE) identity that is presented by incoming IKE connections and includes such things as IP address, fully qualified domain name (FQDN), and group (that is, the virtual private network [VPN] remote client grouping). The granularity of the match identity criteria will impose the granularity of the specified QoS policy, for example, to mark all traffic belonging to the VPN client group named “Engineering” as “TOS 5”. Another example of having the granularity of a specified QoS policy imposed would be to allocate 30 percent of the bandwidth on an outbound WAN link to a specific group of remote VPN devices.

## How to Configure IPsec and Quality of Service

### Configuring IPsec and Quality of Service

To apply QoS policies to an ISAKMP profile, perform the following steps.

**SUMMARY STEPS**

1. **enable**
2. **configure terminal**
3. **crypto isakmp-profile** *profile-number*
4. **qos-group** *group-number*

**DETAILED STEPS**

	<b>Command or Action</b>	<b>Purpose</b>
<b>Step 1</b>	<b>enable</b> <b>Example:</b> Router> enable	Enables privileged EXEC mode. <ul style="list-style-type: none"> <li>• Enter your password if prompted.</li> </ul>
<b>Step 2</b>	<b>configure terminal</b> <b>Example:</b> Router# configure terminal	Enters global configuration mode.
<b>Step 3</b>	<b>crypto isakmp-profile</b> <i>profile-number</i> <b>Example:</b> Router (config)# crypto isakmp-profile vpnprofile	Defines an ISAKMP profile, audits IPsec user sessions, and enters ISAKMP profile configuration mode.
<b>Step 4</b>	<b>qos-group</b> <i>group-number</i> <b>Example:</b> Router(config-isa-prof)# qos-group 1	Applies a QoS group value to an ISAKMP profile.

**Verifying IPsec and Quality of Service Sessions**

To verify your IPsec and QoS sessions, perform the following steps. The **show** commands can be used in any order or independent of each other.

**SUMMARY STEPS**

1. **enable**
2. **show crypto isakmp profile**
3. **show crypto ipsec sa**

**DETAILED STEPS**

	<b>Command or Action</b>	<b>Purpose</b>
<b>Step 1</b>	<b>enable</b> <b>Example:</b>	Enables privileged EXEC mode. <ul style="list-style-type: none"> <li>• Enter your password if prompted.</li> </ul>

	Command or Action	Purpose
	Router> enable	
<b>Step 2</b>	<b>show crypto isakmp profile</b> <b>Example:</b> Router# show crypto isakmp profile	Shows that the QoS group is applied to the profile.
<b>Step 3</b>	<b>show crypto ipsec sa</b> <b>Example:</b> Router# show crypto ipsec sa	Shows that the QoS group is applied to a particular pair of IPsec security associations (SAs).

## Troubleshooting Tips

If you have a problem with your IPsec and QoS sessions, ensure that you have done the following:

- Validated the application of QoS by the QoS service using the QoS-specific commands in the *Cisco IOS Quality of Service Solutions Command Reference*.
- Configured a QoS policy on the router that matches the same QoS group as that specified for the class map match criterion.
- Applied the service policy to the same interface to which a crypto map is applied.

# Configuration Examples for IPsec and Quality of Service

## QoS Policy Applied to Two Groups of Remote Users Example

In the following example, a specific QoS policy is applied to two groups of remote users. Two ISAKMP profiles are configured so that upon initial connection via IKE, remote users are mapped to a specific profile. From that profile, all IPsec SAs that have been created for that remote will be marked with the specific QoS group. As traffic leaves the outbound interface, the QoS service will map the IPsec set QoS group with the QoS group that is specified in the class maps that comprise the service policy that is applied on that outbound interface.

```

version 12.3
!
aaa authentication login group group radius
aaa authorization network autho local
aaa accounting update periodic 1
aaa session-id common
ip subnet-zero
!
!
ip cef
no ip domain lookup
!
class-map match-all yellow

```

```
    match qos-group 3
class-map match-all blue
match qos-group 2
!
!
policy-map clients
class blue
    set precedence 5
class yellow
    set precedence 7
!
!
crypto isakmp policy 1
encr aes
hash sha
authentication pre-share
group 14
lifetime 300
!
crypto isakmp keepalive 10 periodic
crypto isakmp xauth timeout 20
!
crypto isakmp client configuration group blue
key cisco
dns 10.2.2.2 10.2.2.3
wins 10.6.6.6
pool blue
save-password
include-local-lan
backup-gateway corkyl.cisco.com
!
crypto isakmp client configuration group yellow
dns 10.2.2.2 10.2.2.3
wins 10.6.6.5
pool yellow
!
crypto isakmp profile blue
match identity group cisco
client authentication list autho
isakmp authorization list autho
client configuration address respond
qos-group 2
crypto isakmp profile yellow
match identity group yellow
match identity address 10.0.0.11 255.255.255.255
client authentication list autho
isakmp authorization list autho
client configuration address respond
qos-group 3
!
!
crypto ipsec transform-set combo ah-sha-hmac esp-aes esp-sha-hmac
crypto ipsec transform-set client esp-aes esp-sha-hmac comp-lzs
!
crypto dynamic-map mode 1
set security-association lifetime seconds 180
set transform-set client
set isakmp-profile blue
reverse-route
crypto dynamic-map mode 2
set transform-set combo
set isakmp-profile yellow
reverse-route
!
```

**show crypto isakmp profile Command Example**

```

crypto map mode 1 ipsec-isakmp dynamic mode
!
interface FastEthernet0/0
 ip address 10.0.0.110 255.255.255.0
 no ip redirects
 no ip proxy-arp
 no ip mroute-cache
 duplex half
 no cdp enable
 crypto map mode
 service-policy out clients
!
ip local pool yellow 192.168.2.1 192.168.2.10
ip local pool blue 192.168.6.1 192.168.6.6
no ip classless
!
radius-server host 10.0.0.13 auth-port 1645 acct-port 1646
radius-server key XXXXXX
radius-server vsa send accounting
radius-server vsa send authentication

```

**show crypto isakmp profile Command Example**

The following output shows that QoS group “2” has been applied to the ISAKMP profile “blue” and that QoS group “3” has been applied to the ISAKMP profile “yellow”:

```

Router# show crypto isakmp profile
ISAKMP PROFILE blue
  Identities matched are:
    group blue
  QoS Group 2 is applied
ISAKMP PROFILE yellow
  Identities matched are:
    ip-address 10.0.0.13 255.255.255.255
    group yellow
  QoS Group 3 is applied

```

**show crypto ipsec sa Command Example**

The following output shows that the QoS group has been applied to a particular pair of IPsec SAs:

```

Router# show crypto ipsec sa
interface: FastEthernet0/0
  Crypto map tag: mode, local addr. 10.0.0.110
  protected vrf:
  local ident (addr/mask/prot/port): (0.0.0.0/0.0.0.0/0/0)
  remote ident (addr/mask/prot/port): (10.12.12.0/255.255.255.0/0/0)
  current_peer: 10.0.0.11:500
    PERMIT, flags={}
    #pkts encaps: 0, #pkts encrypt: 0, #pkts digest: 0
    #pkts decaps: 0, #pkts decrypt: 0, #pkts verify: 0
    #pkts compressed: 0, #pkts decompressed: 0
    #pkts not compressed: 0, #pkts compr. failed: 0
    #pkts not decompressed: 0, #pkts decompress failed: 0
    #send errors 0, #recv errors 0
    qos group is set to 2

```



## Additional References

The following sections provide references related to the IPsec and Quality of Service feature.

### Related Documents

Related Topic	Document Title
IPsec	Configuring Security for VPNs with IPsec
QoS options	<i>Cisco IOS Quality of Service Solutions Configuration Guide on Cisco.com</i>
QoS commands	<i>Cisco IOS Quality of Service Solutions Command Reference</i>
Security commands	<i>Cisco IOS Security Command Reference</i>
Recommended cryptographic algorithms	<a href="#">Next Generation Encryption</a>

### Standards

Standards	Title
No new or modified standards are supported by this feature.	--

### MIBs

MIBs	MIBs Link
No new or modified MIBs are supported by this feature.	To locate and download MIBs for selected platforms, Cisco IOS releases, and feature sets, use Cisco MIB Locator found at the following URL:  <a href="http://www.cisco.com/go/mibs">http://www.cisco.com/go/mibs</a>

### RFCs

RFCs	Title
No new or modified RFCs are supported by this feature.	--

## Technical Assistance

Description	Link
<p>The Cisco Support website provides extensive online resources, including documentation and tools for troubleshooting and resolving technical issues with Cisco products and technologies.</p> <p>To receive security and technical information about your products, you can subscribe to various services, such as the Product Alert Tool (accessed from Field Notices), the Cisco Technical Services Newsletter, and Really Simple Syndication (RSS) Feeds.</p> <p>Access to most tools on the Cisco Support website requires a Cisco.com user ID and password.</p>	<p><a href="http://www.cisco.com/techsupport">http://www.cisco.com/techsupport</a></p>

## Feature Information for IPsec and Quality of Service

The following table provides release information about the feature or features described in this module. This table lists only the software release that introduced support for a given feature in a given software release train. Unless noted otherwise, subsequent releases of that software release train also support that feature.

Use Cisco Feature Navigator to find information about platform support and Cisco software image support. To access Cisco Feature Navigator, go to [www.cisco.com/go/cfn](http://www.cisco.com/go/cfn). An account on Cisco.com is not required.

**Table 4: Feature Information for IPsec and Quality of Service**

Feature Name	Releases	Feature Information
IPsec and Quality of Service	Cisco IOS XE Release 3.9S	<p>The IPsec and Quality of Service feature allows Cisco IOS quality of service (QoS) policies to be applied to IP Security (IPsec) packet flows on the basis of a QoS group that can be added to the current Internet Security Association and Key Management Protocol (ISAKMP) profile.</p> <p>The following commands were introduced or modified: <b>qos-group.</b></p>



## CHAPTER 8

# VRF-Aware IPsec

The VRF-Aware IPsec feature introduces IP Security (IPsec) tunnel mapping to Multiprotocol Label Switching (MPLS) Virtual Private Networks (VPNs).



**Note** Security threats, as well as the cryptographic technologies to help protect against them, are constantly changing. For more information about the latest Cisco cryptographic recommendations, see the [Next Generation Encryption](#) (NGE) white paper.

- [Finding Feature Information](#), on page 73
- [Restrictions for VRF-Aware IPsec](#), on page 73
- [Information About VRF-Aware IPsec](#), on page 74
- [How to Configure VRF-Aware IPsec](#), on page 76
- [Configuration Examples for VRF-Aware IPsec](#), on page 93
- [Additional References](#), on page 105
- [Feature Information for VRF-Aware IPsec](#), on page 106
- [Glossary](#), on page 106

## Finding Feature Information

Your software release may not support all the features documented in this module. For the latest caveats and feature information, see [Bug Search Tool](#) and the release notes for your platform and software release. To find information about the features documented in this module, and to see a list of the releases in which each feature is supported, see the feature information table.

Use Cisco Feature Navigator to find information about platform support and Cisco software image support. To access Cisco Feature Navigator, go to <https://cfng.cisco.com/>. An account on Cisco.com is not required.

## Restrictions for VRF-Aware IPsec

- If you are configuring the VRF-Aware IPsec feature using a crypto map configuration and the Inside VRF (IVRF) is not the same as the Front Door VRF (FVRF), this feature is not interoperable with unicast reverse path forwarding (uRPF) if uRPF is enabled on the crypto map interface. If your network requires uRPF, it is recommended that you use Virtual Tunnel Interface (VTI) for IPsec instead of crypto maps.

- The VRF-Aware IPsec feature does not allow IPsec tunnel mapping between VRFs. For example, it does not allow IPsec tunnel mapping from VRF vpn1 to VRF vpn2.
- When the VRF-Aware IPsec feature is used with a crypto map, this crypto map cannot use the global VRF as the IVRF and a non-global VRF as the FVRF. However, configurations based on virtual tunnel interfaces do not have that limitation. When VTIs or Dynamic VTIs (DVTIs) are used, the global VRF can be used as the IVRF together with a non-global VRF used as the FVRF.
- You must include the VRF in the **local-address** command when using the local address with VRF in the ISAKMP profile and keyring.

## Information About VRF-Aware IPsec

### VRF Instance

A VRF instance is a per-VPN routing information repository that defines the VPN membership of a customer site attached to the Provider Edge (PE) router. A VRF comprises an IP routing table, a derived Cisco Express Forwarding (CEF) table, a set of interfaces that use the forwarding table, and a set of rules and routing protocol parameters that control the information that is included in the routing table. A separate set of routing and Cisco Express Forwarding (CEF) tables is maintained for each VPN customer.

### MPLS Distribution Protocol

The MPLS distribution protocol is a high-performance packet-forwarding technology that integrates the performance and traffic management capabilities of data link layer switching with the scalability, flexibility, and performance of network-layer routing.

### VRF-Aware IPsec Functional Overview

Front Door VRF (FVRF) and Inside VRF (IVRF) are central to understanding the feature.

Each IPsec tunnel is associated with two VRF domains. The outer encapsulated packet belongs to one VRF domain, which we shall call the FVRF, while the inner, protected IP packet belongs to another domain called the IVRF. Another way of stating the same thing is that the local endpoint of the IPsec tunnel belongs to the FVRF while the source and destination addresses of the inside packet belong to the IVRF.

One or more IPsec tunnels can terminate on a single interface. The FVRF of all these tunnels is the same and is set to the VRF that is configured on that interface. The IVRF of these tunnels can be different and depends on the VRF that is defined in the Internet Security Association and Key Management Protocol (ISAKMP) profile that is attached to a crypto map entry.

The diagram below is an illustration of a scenario showing IPsec to MPLS and Layer 2 VPNs.

Figure 2: IPsec to MPLS and Layer 2 VPNs

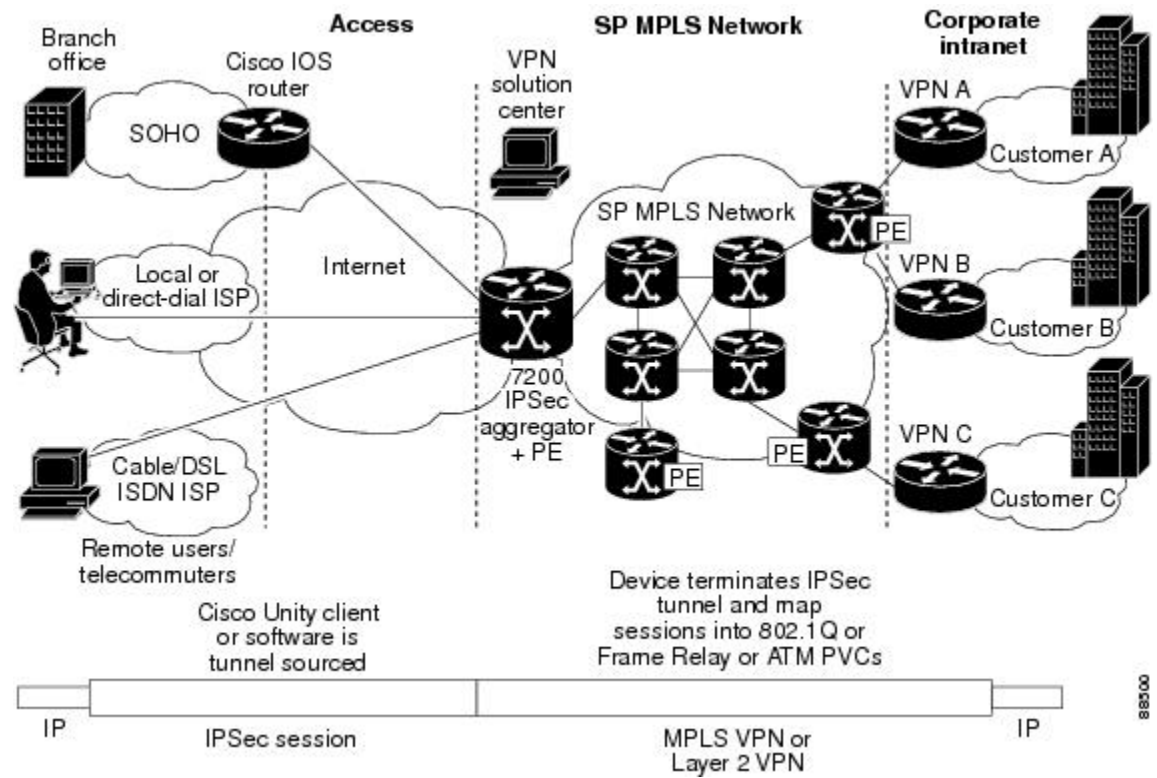

## Packet Flow into the IPsec Tunnel

- A VPN packet arrives from the Service Provider MPLS backbone network to the PE and is routed through an interface facing the Internet.
- The packet is matched against the Security Policy Database (SPD), and the packet is IPsec encapsulated. The SPD includes the IVRF and the access control list (ACL).
- The IPsec encapsulated packet is then forwarded using the FVRF routing table.

## Packet Flow from the IPsec Tunnel

- An IPsec-encapsulated packet arrives at the PE router from the remote IPsec endpoint.
- IPsec performs the Security Association (SA) lookup for the Security Parameter Index (SPI), destination, and protocol.
- The packet is decapsulated using the SA and is associated with IVRF.
- The packet is further forwarded using the IVRF routing table.

# How to Configure VRF-Aware IPsec

## Configuring Crypto Keyrings

A crypto keyring is a repository of preshared and Rivest, Shamir, and Adelman (RSA) public keys. There can be zero or more keyrings on the Cisco IOS router.

### SUMMARY STEPS

1. **enable**
2. **configure terminal**
3. **crypto keyring** *keyring-name* [**vrf** *fvrf-name*]
4. **description** *string*
5. **pre-shared-key** {**address** *address* [*mask*] | **hostname** *hostname*} **key** *key*
6. **rsa-pubkey** {**address** *address* | **name** *fqdn*} [**encryption** | **signature**]
7. **address** *ip-address*
8. **serial-number** *serial-number*
9. **key-string**
10. **text**
11. **quit**
12. **exit**
13. **exit**

### DETAILED STEPS

	Command or Action	Purpose
<b>Step 1</b>	<b>enable</b>  <b>Example:</b>  Router> enable	Enables privileged EXEC mode.  • Enter your password if prompted.
<b>Step 2</b>	<b>configure terminal</b>  <b>Example:</b>  Router# configure terminal	Enters global configuration mode.
<b>Step 3</b>	<b>crypto keyring</b> <i>keyring-name</i> [ <b>vrf</b> <i>fvrf-name</i> ]  <b>Example:</b>  Router (config)# crypto keyring VPN1	Defines a keyring with <i>keyring-name</i> as the name of the keyring and enters keyring configuration mode.  • (Optional) The <b>vrf</b> keyword and <i>fvrf-name</i> argument imply that the keyring is bound to Front Door Virtual Routing and Forwarding (FVRF). The key in the keyring is searched if the local endpoint is in FVRF. If <b>vrf</b> is not specified, the keyring is bound to the global.

	Command or Action	Purpose
Step 4	<p><b>description</b> <i>string</i></p> <p><b>Example:</b></p> <p><b>Example:</b></p> <pre>Router (config-keyring)# description The keys for VPN1</pre>	(Optional) Specifies a one-line description of the keyring.
Step 5	<p><b>pre-shared-key</b> {<b>address</b> <i>address</i> [<i>mask</i>]   <b>hostname</b> <i>hostname</i>} <b>key</b> <i>key</i></p> <p><b>Example:</b></p> <pre>Router (config-keyring)# pre-shared-key address 10.72.23.11 key VPN1</pre>	(Optional) Defines a preshared key by address or host name.
Step 6	<p><b>rsa-pubkey</b> {<b>address</b> <i>address</i>   <b>name</b> <i>fqdn</i>} [<b>encryption</b>   <b>signature</b>]</p> <p><b>Example:</b></p> <pre>Router(config-keyring)# rsa-pubkey name host.vpn.com</pre>	<p>(Optional) Defines an RSA public key by address or host name and enters rsa-pubkey configuration mode.</p> <ul style="list-style-type: none"> <li>• The optional <b>encryption</b> keyword specifies that the key should be used for encryption.</li> <li>• The optional <b>signature</b> keyword specifies that the key should be used for signature. By default, the key is used for signature.</li> </ul>
Step 7	<p><b>address</b> <i>ip-address</i></p> <p><b>Example:</b></p> <pre>Router(config-pubkey-key)# address 10.5.5.1</pre>	(Optional) Defines the RSA public key IP address.
Step 8	<p><b>serial-number</b> <i>serial-number</i></p> <p><b>Example:</b></p> <pre>Router(config-pubkey-key)# serial-number 1000000</pre>	(Optional) Specifies the serial number of the public key. The value is from 0 through infinity.
Step 9	<p><b>key-string</b></p> <p><b>Example:</b></p> <pre>Router (config-pubkey-key)# key-string</pre>	Enters into the text mode in which you define the public key.
Step 10	<p><b>text</b></p> <p><b>Example:</b></p> <pre>Router (config-pubkey)# 00302017 4A7D385B 1234EF29 335FC973</pre>	<p>Specifies the public key.</p> <p><b>Note</b> Only one public key may be added in this step.</p>
Step 11	<p><b>quit</b></p> <p><b>Example:</b></p>	Quits to the public key configuration mode.

	Command or Action	Purpose
	Router (config-pubkey)# quit	
<b>Step 12</b>	<b>exit</b> <b>Example:</b> Router (config-pubkey)# exit	Exits to the keyring configuration mode.
<b>Step 13</b>	<b>exit</b> <b>Example:</b> Router (config-keyring)# exit#	Exits to global configuration mode.

## Configuring ISAKMP Profiles

An ISAKMP profile is a repository for Internet Key Exchange (IKE) Phase 1 and IKE Phase 1.5 configuration for a set of peers. An ISAKMP profile defines items such as keepalive, trustpoints, peer identities, and XAUTH AAA list during the IKE Phase 1 and Phase 1.5 exchange. There can be zero or more ISAKMP profiles on the Cisco IOS router.



**Note** If traffic from the router to a certification authority (CA) (for authentication, enrollment, or for obtaining a certificate revocation list [CRL]) or to an Lightweight Directory Access Protocol (LDAP) server (for obtaining a CRL) needs to be routed via a VRF, the **vrf** command must be added to the trustpoint. Otherwise, the traffic uses the default routing table.

- If a profile does not specify one or more trustpoints, all trustpoints in the router will be used to attempt to validate the certificate of the peer (IKE main mode or signature authentication). If one or more trustpoints are specified, only those trustpoints will be used.



**Note** A router initiating IKE and a router responding to the IKE request should have symmetrical trustpoint configurations. For example, a responding router (in IKE Main Mode) performing RSA signature encryption and authentication might use trustpoints that were defined in the global configuration when sending the CERT-REQ payloads. However, the router might use a restricted list of trustpoints that were defined in the ISAKMP profile for the certificate verification. If the peer (the IKE initiator) is configured to use a certificate whose trustpoint is in the global list of the responding router but not in ISAKMP profile of the responding router, the certificate will be rejected. (However, if the initiating router does not know about the trustpoints in the global configuration of the responding router, the certificate can still be authenticated.)

>

### SUMMARY STEPS

1. **enable**
2. **configure terminal**



3. **crypto isakmp profile** *profile-name*
4. **description** *string*
5. **vrf** *ivrf-name*
6. **keepalive** *seconds* **retry** *retry-seconds*
7. **self-identity** {*address* | *fqdn* | **user-fqdn** *user-fqdn*}
8. **keyring** *keyring-name*
9. **ca trust-point** {*trustpoint-name*}
10. **match identity** {**group** *group-name* | **address** *address* [*mask*] [*fvr*] | **host** *host-name* | **host domain** *domain-name* | **user** *user-fqdn* | **user domain** *domain-name*}
11. **client configuration address** {**initiate** | **respond**}
12. **client authentication list** *list-name*
13. **isakmp authorization list** *list-name*
14. **initiate mode aggressive**
15. **exit**

## DETAILED STEPS

	Command or Action	Purpose
<b>Step 1</b>	<b>enable</b> <b>Example:</b> <pre>Router&gt; enable</pre>	Enables privileged EXEC mode. <ul style="list-style-type: none"> <li>• Enter your password if prompted.</li> </ul>
<b>Step 2</b>	<b>configure terminal</b> <b>Example:</b> <pre>Router# configure terminal</pre>	Enters global configuration mode.
<b>Step 3</b>	<b>crypto isakmp profile</b> <i>profile-name</i> <b>Example:</b> <pre>Router (config)# crypto isakmp profile vpnprofile</pre>	Defines an Internet Security Association and Key Management Protocol (ISAKMP) profile and enters into isakmp profile configuration mode.
<b>Step 4</b>	<b>description</b> <i>string</i> <b>Example:</b> <pre>Router (conf-isa-prof)# description configuration for VPN profile</pre>	(Optional) Specifies a one-line description of an ISAKMP profile.
<b>Step 5</b>	<b>vrf</b> <i>ivrf-name</i> <b>Example:</b> <pre>Router (conf-isa-prof)# vrf VPN1</pre>	(Optional) Maps the IPsec tunnel to a Virtual Routing and Forwarding (VRF) instance.  <b>Note</b> The VRF also serves as a selector for matching the Security Policy Database (SPD). If the VRF is not specified in the ISAKMP profile, the IVRF of the IPsec tunnel will be the same as its FVRF.

	Command or Action	Purpose
<b>Step 6</b>	<p><b>keepalive</b> <i>seconds</i> <b>retry</b> <i>retry-seconds</i></p> <p><b>Example:</b></p> <pre>Router (conf-isa-prof)# keepalive 60 retry 5</pre>	<p>(Optional) Allows the gateway to send dead peer detection (DPD) messages to the peer.</p> <ul style="list-style-type: none"> <li>• If not defined, the gateway uses the global configured value.</li> <li>• <i>seconds</i> --Number of seconds between DPD messages. The range is 10 to 3600 seconds.</li> <li>• <b>retry</b> <i>retry-seconds</i> --Number of seconds between retries if the DPD message fails. The range is 2 to 60 seconds.</li> </ul>
<b>Step 7</b>	<p><b>self-identity</b> {<i>address</i>   <i>fqdn</i>   <i>user-fqdn</i> <i>user-fqdn</i>}</p> <p><b>Example:</b></p> <pre>Router (conf-isa-prof)# self-identity address</pre>	<p>(Optional) Specifies the identity that the local Internet Key Exchange (IKE) should use to identify itself to the remote peer.</p> <ul style="list-style-type: none"> <li>• If not defined, IKE uses the global configured value.</li> <li>• <b>address</b> --Uses the IP address of the egress interface.</li> <li>• <b>fqdn</b>-- Uses the fully qualified domain name (FQDN) of the router.</li> <li>• <b>user-fqdn</b> --Uses the specified value.</li> </ul>
<b>Step 8</b>	<p><b>keyring</b> <i>keyring-name</i></p> <p><b>Example:</b></p> <pre>Router (conf-isa-prof)# keyring VPN1</pre>	<p>(Optional) Specifies the keyring to use for Phase 1 authentication.</p> <ul style="list-style-type: none"> <li>• If the keyring is not specified, the global key definitions are used.</li> </ul>
<b>Step 9</b>	<p><b>ca trust-point</b> {<i>trustpoint-name</i>}</p> <p><b>Example:</b></p> <pre>Router (conf-isa-prof)# ca trustpoint VPN1-trustpoint</pre>	<p>(Optional) Specifies a trustpoint to validate a Rivest, Shamir, and Adelman (RSA) certificate.</p> <ul style="list-style-type: none"> <li>• If no trustpoint is specified in the ISAKMP profile, all the trustpoints that are configured on the Cisco IOS router are used to validate the certificate.</li> </ul>
<b>Step 10</b>	<p><b>match identity</b> {<b>group</b> <i>group-name</i>   <b>address</b> <i>address</i> [<i>mask</i>] [<i>fvr</i>]   <b>host</b> <i>host-name</i>   <b>host domain</b> <i>domain-name</i>   <b>user</b> <i>user-fqdn</i>   <b>user domain</b> <i>domain-name</i>}</p> <p><b>Example:</b></p> <pre>Router (conf-isa-prof)# match identity address 10.1.1.1</pre>	<p>Specifies the client IKE Identity (ID) that is to be matched.</p> <ul style="list-style-type: none"> <li>• <b>group</b> <i>group-name</i> --Matches the <i>group-name</i> with the ID type ID_KEY_ID. It also matches the <i>group-name</i> with the Organizational Unit (OU) field of the Distinguished Name (DN).</li> <li>• <b>address</b> <i>address</i> [<i>mask</i>] <i>fvr</i> --Matches the <i>address</i> with the ID type ID_IPV4_ADDR. The <i>mask</i> argument can be used to specify a range of addresses. The <i>fvr</i> argument specifies that the address is in Front Door Virtual Routing and Forwarding (FVRF)</li> </ul>

	Command or Action	Purpose
		<ul style="list-style-type: none"> <li>• <b>host</b> <i>hostname</i> --Matches the <i>hostname</i> with the ID type ID_FQDN.</li> <li>• <b>host domain</b> <i>domain-name</i> --Matches the <i>domain-name</i> to the ID type ID_FQDN whose domain name is the same as the <i>domain-name</i>. Use this command to match all the hosts in the domain.</li> <li>• <b>user</b> <i>username</i> --Matches the <i>username</i> with the ID type ID_USER_FQDN.</li> <li>• <b>user domain</b> <i>domainname</i> --Matches the ID type ID_USER_FQDN whose domain name matches the <i>domainname</i>.</li> </ul>
<b>Step 11</b>	<b>client configuration address</b> {initiate   respond} <b>Example:</b> <pre>Router (conf-isa-prof)# client configuration address initiate</pre>	(Optional) Specifies whether to initiate the mode configuration exchange or responds to mode configuration requests.
<b>Step 12</b>	<b>client authentication list</b> <i>list-name</i> <b>Example:</b> <pre>Router (conf-isa-prof)# client authentication list xauthlist</pre>	(Optional) AAA (authentication, authorization, and accounting) to use for authenticating the remote client during the extended authentication (XAUTH) exchange.
<b>Step 13</b>	<b>isakmp authorization list</b> <i>list-name</i> <b>Example:</b> <pre>Router (conf-isa-prof)# isakmp authorization list ikessaaalist</pre>	(Optional) Network authorization server for receiving the Phase 1 preshared key and other attribute-value (AV) pairs.
<b>Step 14</b>	<b>initiate mode aggressive</b> <b>Example:</b> <pre>Router (conf-isa-prof)# initiate mode aggressive</pre>	(Optional) Initiates aggressive mode exchange. <ul style="list-style-type: none"> <li>• If not specified, IKE always initiates main mode exchange.</li> </ul>
<b>Step 15</b>	<b>exit</b> <b>Example:</b> <pre>Router (conf-isa-prof)# exit</pre>	Exits to global configuration mode.

## What to Do Next

Go to the section [Configuring an ISAKMP Profile on a Crypto Map, on page 82.](#)”

## Configuring an ISAKMP Profile on a Crypto Map

An ISAKMP profile must be applied to the crypto map. The IVRF on the ISAKMP profile is used as a selector when matching the VPN traffic. If there is no IVRF on the ISAKMP profile, the IVRF will be equal to the FVRF. Perform this task to configure an ISAKMP profile on a crypto map.

### Before you begin

Before configuring an ISAKMP profile on a crypto map, you must first configure your router for basic IPsec.

### SUMMARY STEPS

1. **enable**
2. **configure terminal**
3. **crypto map** *map-name* **isakmp-profile** *isakmp-profile-name*
4. **set isakmp-profile** *profile-name*
5. **exit**

### DETAILED STEPS

	Command or Action	Purpose
<b>Step 1</b>	<b>enable</b> <b>Example:</b> <pre>Router&gt; enable</pre>	Enables privileged EXEC mode. <ul style="list-style-type: none"> <li>• Enter your password if prompted.</li> </ul>
<b>Step 2</b>	<b>configure terminal</b> <b>Example:</b> <pre>Router# configure terminal</pre>	Enters global configuration mode.
<b>Step 3</b>	<b>crypto map</b> <i>map-name</i> <b>isakmp-profile</b> <i>isakmp-profile-name</i> <b>Example:</b> <pre>Router (config)# crypto map vpnmap isakmp-profile vpnprofile</pre>	(Optional) Specifies the Internet Key Exchange and Key Management Protocol (ISAKMP) profile for the crypto map set and enters crypto map configuration mode. <ul style="list-style-type: none"> <li>• The ISAKMP profile will be used during IKE exchange.</li> </ul>
<b>Step 4</b>	<b>set isakmp-profile</b> <i>profile-name</i> <b>Example:</b> <pre>Router (config-crypto-map)# set isakmp-profile vpnprofile</pre>	(Optional) Specifies the ISAKMP profile to use when the traffic matches the crypto map entry.
<b>Step 5</b>	<b>exit</b> <b>Example:</b> <pre>Router (config-crypto-map)# exit</pre>	Exits to global configuration mode.

## Configuring to Ignore Extended Authentication During IKE Phase 1 Negotiation

To ignore XAUTH during an IKE Phase 1 negotiation, use the **no crypto xauth** command. Use the **no crypto xauth** command if you do not require extended authentication for the Unity clients.

### SUMMARY STEPS

1. **enable**
2. **configure terminal**
3. **no crypto xauth** *interface*

### DETAILED STEPS

	Command or Action	Purpose
Step 1	<b>enable</b> <b>Example:</b> <pre>Router&gt; enable</pre>	Enables privileged EXEC mode. <ul style="list-style-type: none"> <li>• Enter your password if prompted.</li> </ul>
Step 2	<b>configure terminal</b> <b>Example:</b> <pre>Router# configure terminal</pre>	Enters global configuration mode.
Step 3	<b>no crypto xauth</b> <i>interface</i> <b>Example:</b> <pre>Router(config)# no crypto xauth ethernet0</pre>	Ignores XAUTH proposals for requests that are destined to the IP address of the interface. By default, Internet Key Exchange (IKE) processes XAUTH proposals.

## Verifying VRF-Aware IPsec

To verify your VRF-Aware IPsec configurations, use the following **show** commands. These **show** commands allow you to list configuration information and security associations (SAs):

### SUMMARY STEPS

1. **enable**
2. **show crypto ipsec sa** [**map** *map-name*] **address** | **identity** | **interface** *interface* | **peer** [**vrf** *vrf-name*] **address** | **vrf** *vrf-name*] [**detail**]
3. **show crypto isakmp key**
4. **show crypto isakmp profile**
5. **show crypto key pubkey-chain rsa**

### DETAILED STEPS

	Command or Action	Purpose
Step 1	<b>enable</b>	Enables privileged EXEC mode.

	Command or Action	Purpose
	<b>Example:</b>  <pre>Router&gt; enable</pre>	<ul style="list-style-type: none"> <li>Enter your password if prompted.</li> </ul>
<b>Step 2</b>	<b>show crypto ipsec sa</b> [map <i>map-name</i> ] <b>address</b>   <b>identity</b>   <b>interface</b> <i>interface</i> / <b>peer</b> [ <b>vrf</b> <i>fvr-f-name</i> ] <b>address</b>   <b>vrf</b> <i>ivrf-name</i> ] [ <b>detail</b> ]  <b>Example:</b>  <pre>Router# show crypto ipsec sa vrf vpn1</pre>	Allows you to view the settings used by current security associations (SAs).
<b>Step 3</b>	<b>show crypto isakmp key</b>  <b>Example:</b>  <pre>Router# show crypto isakmp key</pre>	Lists all the keyrings and their preshared keys. <ul style="list-style-type: none"> <li>Use this command to verify your crypto keyring configuration.</li> </ul>
<b>Step 4</b>	<b>show crypto isakmp profile</b>  <b>Example:</b>  <pre>Router# show crypto isakmp profile</pre>	Lists all ISAKMP profiles and their configurations.
<b>Step 5</b>	<b>show crypto key pubkey-chain rsa</b>  <b>Example:</b>  <pre>Router# show crypto key pubkey-chain rsa</pre>	Views the RSA public keys of the peer that are stored on your router. <ul style="list-style-type: none"> <li>The output is extended to show the keyring to which the public key belongs.</li> </ul>

## Clearing Security Associations

The following **clear** commands allow you to clear SAs.

### SUMMARY STEPS

- enable**
- clear crypto sa** [counters | map *map-name* | peer[**vrf** *fvr-f-name*] *address* | spi *address* {**ah** | **esp**} spi | **vrf** *ivrf-name*]

### DETAILED STEPS

	Command or Action	Purpose
<b>Step 1</b>	<b>enable</b>  <b>Example:</b>  <pre>Router&gt; enable</pre>	Enables privileged EXEC mode. <ul style="list-style-type: none"> <li>Enter your password if prompted.</li> </ul>

	Command or Action	Purpose
<b>Step 2</b>	<pre>clear crypto sa [counters   map map-name   peer[vrf fvrf-name] address   spi address {ah   esp} spi   vrf ivrf-name]</pre> <p><b>Example:</b></p> <pre>Router# clear crypto sa vrf VPN1</pre>	Clears the IPsec security associations (SAs).

## Troubleshooting VRF-Aware IPsec

To troubleshoot VRF-Aware IPsec, use the following **debug** commands:

### SUMMARY STEPS

1. **enable**
2. **debug crypto ipsec**
3. **debug crypto isakmp**

### DETAILED STEPS

	Command or Action	Purpose
<b>Step 1</b>	<pre>enable</pre> <p><b>Example:</b></p> <pre>Router&gt; enable</pre>	Enables privileged EXEC mode. <ul style="list-style-type: none"> <li>• Enter your password if prompted.</li> </ul>
<b>Step 2</b>	<pre>debug crypto ipsec</pre> <p><b>Example:</b></p> <pre>Router# debug crypto ipsec</pre>	Displays IP security (IPsec) events.
<b>Step 3</b>	<pre>debug crypto isakmp</pre> <p><b>Example:</b></p> <pre>Router(config)# debug crypto isakmp</pre>	Displays messages about Internet Key Exchange (IKE) events.

## Debug Examples for VRF-Aware IPsec

The following sample debug outputs are for a VRF-aware IPsec configuration:

### IPsec PE

```
Router# debug crypto ipsec
Crypto IPSEC debugging is on
IPSEC-PE#debug crypto isakmp
Crypto ISAKMP debugging is on
IPSEC-PE#debug crypto isakmp d
04:31:28: ISAKMP (0:12): purging SA., sa=6482B354, delme=6482B354
```

```

04:31:28: ISAKMP: Unlocking IKE struct 0x63C142F8 for declare_sa_dead(), count 0
IPSEC-PE#debug crypto isakmp detail
Crypto ISAKMP internals debugging is on
IPSEC-PE#
IPSEC-PE#
IPSEC-PE#
04:32:07: ISAKMP: Deleting peer node by peer_reap for 10.1.1.1: 63C142F8
04:32:55: ISAKMP cookie gen for src 172.16.1.1 dst 10.1.1.1
04:32:55: ISAKMP cookie 3123100B DC887D4E
04:32:55: ISAKMP cookie gen for src 10.1.1.1 dst 172.68.1.1
04:32:55: ISAKMP cookie AA8F7B41 49A60E88
04:32:55: ISAKMP cookie gen for src 172.16.1.1 dst 10.1.1.1
04:32:55: ISAKMP cookie 3123100B DBC8E125
04:32:55: ISAKMP cookie gen for src 10.1.1.1 dst 172.16.1.1
04:32:55: ISAKMP cookie AA8F7B41 B4BDB5B7
04:32:55: ISAKMP (0:0): received packet from 10.1.1.1 dport 500 sport 500 Global (N) NEW
SA
04:32:55: ISAKMP: local port 500, remote port 500
04:32:55: ISAKMP: hash from 729FA94 for 619 bytes
04:32:55: ISAKMP: Packet hash:
64218CC0:          B91E2C70 095A1346          9.,p.Z.F
64218CD0: 0EDB4CA6 8A46784F B314FD3B 00          .[L&.FxO.]);.
04:32:55: ISAKMP cookie gen for src 10.1.1.1 dst 172.18.1.1
04:32:55: ISAKMP cookie AA8F7B41 F7ACF384
04:32:55: ISAKMP cookie gen for src 10.1.1.1 dst 172.18.1.1
04:32:55: ISAKMP cookie AA8F7B41 0C07C670
04:32:55: ISAKMP: insert sa successfully sa = 6482B354
04:32:55: ISAKMP (0:13): processing SA payload. message ID = 0
04:32:55: ISAKMP (0:13): processing ID payload. message ID = 0
04:32:55: ISAKMP (0:13): peer matches vpn2-ra profile
04:32:55: ISAKMP: Looking for a matching key for 10.1.1.1 in default
04:32:55: ISAKMP: Created a peer struct for 10.1.1.1, peer port 500
04:32:55: ISAKMP: Locking peer struct 0x640BBB18, IKE refcount 1 for
crypto_ikmp_config_initialize_sa
04:32:55: ISAKMP (0:13): Setting client config settings 648252B0
04:32:55: ISAKMP (0:13): (Re)Setting client xauth list and state
04:32:55: ISAKMP (0:13): processing vendor id payload
04:32:55: ISAKMP (0:13): vendor ID seems Unity/DPD but major 157 mismatch
04:32:55: ISAKMP (0:13): vendor ID is NAT-T v3
04:32:55: ISAKMP (0:13): processing vendor id payload
04:32:55: ISAKMP (0:13): vendor ID seems Unity/DPD but major 123 mismatch
04:32:55: ISAKMP (0:13): vendor ID is NAT-T v2
04:32:55: ISAKMP (0:13) Authentication by xauth preshared
04:32:55: ISAKMP (0:13): Checking ISAKMP transform 1 against priority 1 policy
04:32:55: ISAKMP:          encryption AES-CBC
04:32:55: ISAKMP:          hash SHA
04:32:55: ISAKMP:          default group 14
04:32:55: ISAKMP:          auth XAUTHInitPreShared
04:32:55: ISAKMP:          life type in seconds
04:32:55: ISAKMP:          life duration (VPI) of 0x0 0x20 0xC4 0x9B
04:32:55: ISAKMP (0:13): atts are acceptable. Next payload is 3
04:32:55: ISAKMP (0:13): processing vendor id payload
04:32:55: ISAKMP (0:13): vendor ID seems Unity/DPD but major 157 mismatch
04:32:55: ISAKMP (0:13): vendor ID is NAT-T v3
04:32:55: ISAKMP (0:13): processing vendor id payload
04:32:55: ISAKMP (0:13): vendor ID seems Unity/DPD but major 123 mismatch
04:32:55: ISAKMP (0:13): vendor ID is NAT-T v2
04:32:55: ISAKMP (0:13): processing KE payload. message ID = 0
04:32:55: ISAKMP (0:13): processing NONCE payload. message ID = 0
04:32:55: ISAKMP (0:13): processing vendor id payload
04:32:55: ISAKMP (0:13): vendor ID is DPD
04:32:55: ISAKMP (0:13): processing vendor id payload
04:32:55: ISAKMP (0:13): vendor ID seems Unity/DPD but major 175 mismatch
04:32:55: ISAKMP (0:13): vendor ID is XAUTH

```



```

04:32:55: ISAKMP (0:13): processing vendor id payload
04:32:55: ISAKMP (0:13): claimed IOS but failed authentication
04:32:55: ISAKMP (0:13): processing vendor id payload
04:32:55: ISAKMP (0:13): vendor ID is Unity
04:32:55: ISAKMP (0:13): Input = IKE_MSG_FROM_PEER, IKE_AM_EXCH
04:32:55: ISAKMP (0:13): Old State = IKE_READY New State = IKE_R_AM_AAA_AWAIT
04:32:55: ISAKMP cookie gen for src 11.1.1.1 dst 172.16.1.1
04:32:55: ISAKMP cookie AA8F7B41 7AE6E1DF
04:32:55: ISAKMP:      isadb_post_process_list: crawler: 4 AA 31 (6482B354)
04:32:55:      crawler my_cookie AA8F7B41 F7ACF384
04:32:55:      crawler his_cookie E46E088D F227FE4D
04:32:55: ISAKMP: got callback 1
04:32:55: ISAKMP (0:13): SKEYID state generated
04:32:55: ISAKMP: Unity/DPD ID: vendor_id_payload:
      next: 0xD, reserved: 0x0, len 0x14
04:32:55: ISAKMP: Unity/DPD ID payload dump:
63E66D70:      0D000014      ....
63E66D80: 12F5F28C 457168A9 702D9FE2 74CC0100 .ur.Eqh)p-.btL..
63E66D90: 00
04:32:55: ISAKMP: Unity/DPD ID: vendor_id_payload:
      next: 0xD, reserved: 0x0, len 0x14
04:32:55: ISAKMP: Unity/DPD ID payload dump:
63E66D90: 0D000014 AFCAD713 68A1F1C9 6B8696FC ..../JW.h!qIk..|
63E66DA0: 77570100 00      wW...
04:32:55: ISAKMP (0:13): constructed NAT-T vendor-03 ID
04:32:55: ISAKMP (0:13): SA is doing pre-shared key authentication plus XAUTH using id type
      ID_IPV4_ADDR
04:32:55: ISAKMP (13): ID payload
      next-payload : 10
      type      : 1
      addr      : 172.16.1.1
      protocol   : 17
      port      : 0
      length    : 8
04:32:55: ISAKMP (13): Total payload length: 12
04:32:55: ISAKMP (0:13): constructed HIS NAT-D
04:32:55: ISAKMP (0:13): constructed MINE NAT-D
04:32:55: ISAKMP (0:13): sending packet to 10.1.1.1 my_port 500 peer_port 500 (R) AG_INIT_EXCH
04:32:55: ISAKMP (0:13): Input = IKE_MSG_FROM_AAA, PRESHARED_KEY_REPLY
04:32:55: ISAKMP (0:13): Old State = IKE_R_AM_AAA_AWAIT New State = IKE_R_AM2
04:32:55: ISAKMP cookie gen for src 172.16.1.1 dst 10.1.1.1
04:32:55: ISAKMP cookie 3123100B D99DA70D
04:32:55: ISAKMP cookie gen for src 10.1.1.1 dst 172.16.1.1
04:32:55: ISAKMP cookie AA8F7B41 9C69F917
04:32:55: ISAKMP:      isadb_post_process_list: crawler: 5 21FF 1 (6482B354)
04:32:55:      crawler my_cookie AA8F7B41 F7ACF384
04:32:55:      crawler his_cookie E46E088D F227FE4D
04:32:55: ISAKMP cookie gen for src 172.16.1.1 dst 10.1.1.1
04:32:55: ISAKMP cookie 3123100B 00583224
04:32:55: ISAKMP cookie gen for src 10.1.1.1 dst 172.16.1.1
04:32:55: ISAKMP cookie AA8F7B41 C1B006EE
04:32:55: ISAKMP:      isadb_post_process_list: crawler: 5 21FF 1 (6482B354)
04:32:55:      crawler my_cookie AA8F7B41 F7ACF384
04:32:55:      crawler his_cookie E46E088D F227FE4D
04:32:55: ISAKMP (0:13): received packet from 10.1.1.1 dport 500 sport 500 Global (R)
AG_INIT_EXCH
04:32:55: ISAKMP: hash from 7003A34 for 132 bytes
04:32:55: ISAKMP: Packet hash:
64218CC0:      D1202D99 2BB49D38      Q -.+4.8
64218CD0: B8FBB1BE 7CDC67D7 4E26126C 63      8{1>|\gWN&.lc
04:32:55: ISAKMP (0:13): processing HASH payload. message ID = 0
04:32:55: ISAKMP:received payload type 17
04:32:55: ISAKMP (0:13): Detected NAT-D payload
04:32:55: ISAKMP (0:13): recalc my hash for NAT-D

```

```

04:32:55: ISAKMP (0:13): NAT match MINE hash
04:32:55: ISAKMP:received payload type 17
04:32:55: ISAKMP (0:13): Detected NAT-D payload
04:32:55: ISAKMP (0:13): recalc his hash for NAT-D
04:32:55: ISAKMP (0:13): NAT match HIS hash
04:32:55: ISAKMP (0:13): processing NOTIFY INITIAL_CONTACT protocol 1
      spi 0, message ID = 0, sa = 6482B354
04:32:55: ISAKMP (0:13): Process initial contact,
bring down existing phase 1 and 2 SA's with local 172.16.1.1 remote 10.1.1.1 remote port
500
04:32:55: ISAKMP (0:13): returning IP addr to the address pool
04:32:55: ISAKMP cookie gen for src 10.1.1.1 dst 172.16.1.1
04:32:55: ISAKMP cookie AA8F7B41 05D315C5
04:32:55: ISAKMP cookie gen for src 172.16.1.1 dst 10.1.1.1
04:32:55: ISAKMP cookie 3123100B 041A85A6
04:32:55: ISAKMP (0:13): SA has been authenticated with 10.1.1.1
04:32:55: ISAKMP: Trying to insert a peer 172.16.1.1/10.1.1.1/500/, and inserted
successfully.
04:32:55: ISAKMP: set new node -803402627 to CONF_XAUTH
04:32:55: IPSEC(key_engine): got a queue event...
04:32:55: ISAKMP (0:13): sending packet to 10.1.1.1 my_port 500 peer_port 500 (R) QM_IDLE

04:32:55: ISAKMP (0:13): purging node -803402627
04:32:55: ISAKMP: Sending phase 1 responder lifetime 86400
04:32:55: ISAKMP (0:13): Input = IKE_MESG_FROM_PEER, IKE_AM_EXCH
04:32:55: ISAKMP (0:13): Old State = IKE_R_AM2 New State = IKE_P1_COMPLETE
04:32:55: ISAKMP cookie gen for src 10.1.1.1 dst 172.168.1.1
04:32:55: ISAKMP cookie AA8F7B41 25EEF256
04:32:55: ISAKMP:      isadb_post_process_list: crawler: 9 27FF 2 (6482B354)
04:32:55:      crawler my_cookie AA8F7B41 F7ACF384
04:32:55:      crawler his_cookie E46E088D F227FE4D
04:32:55: ISAKMP (0:13): Need XAUTH
04:32:55: ISAKMP (0:13): Input = IKE_MESG_INTERNAL, IKE_PHASE1_COMPLETE
04:32:55: ISAKMP (0:13): Old State = IKE_P1_COMPLETE New State =
IKE_XAUTH AAA_START_LOGIN_AWAIT
04:32:55: ISAKMP cookie gen for src 10.1.1.1 dst 172.16.1.1
04:32:55: ISAKMP cookie AA8F7B41 2CCFA491
04:32:55: ISAKMP:      isadb_post_process_list: crawler: B 27FF 12 (6482B354)
04:32:55:      crawler my_cookie AA8F7B41 F7ACF384
04:32:55:      crawler his_cookie E46E088D F227FE4D
04:32:55: ISAKMP: got callback 1
04:32:55: ISAKMP: set new node -1447732198 to CONF_XAUTH
04:32:55: ISAKMP/xauth: request attribute XAUTH_USER_NAME_V2
04:32:55: ISAKMP/xauth: request attribute XAUTH_USER_PASSWORD_V2
04:32:55: ISAKMP (0:13): initiating peer config to 10.1.1.1. ID = -1447732198
04:32:55: ISAKMP (0:13): sending packet to 10.1.1.1 my_port 500 peer_port 500 (R) CONF_XAUTH

04:32:55: ISAKMP (0:13): Input = IKE_MESG_FROM_AAA, IKE_AAA_START_LOGIN
04:32:55: ISAKMP (0:13): Old State = IKE_XAUTH_AAA_START_LOGIN_AWAIT New State =
IKE_XAUTH_REQ_SENT
04:33:00: ISAKMP (0:13): retransmitting phase 2 CONF_XAUTH -1447732198 ...
04:33:00: ISAKMP (0:13): incrementing error counter on sa: retransmit phase 2
04:33:00: ISAKMP (0:13): incrementing error counter on sa: retransmit phase 2
04:33:00: ISAKMP (0:13): retransmitting phase 2 -1447732198 CONF_XAUTH
04:33:00: ISAKMP (0:13): sending packet to 10.1.1.1 my_port 500 peer_port 500 (R) CONF_XAUTH

04:33:03: ISAKMP cookie gen for src 172.18.1.1 dst 10.1.1.1
04:33:03: ISAKMP cookie 3123100B 124D4618
04:33:03: ISAKMP cookie gen for src 10.1.1.1 dst 172.18.1.1
04:33:03: ISAKMP cookie AA8F7B41 B0C91917
04:33:03: ISAKMP:      isadb_post_process_list: crawler: B 27FF 2 (6482B354)
04:33:03:      crawler my_cookie AA8F7B41 F7ACF384
04:33:03:      crawler his_cookie E46E088D F227FE4D
04:33:03: ISAKMP cookie gen for src 172.18.1.1 dst 10.1.1.1

```

```

04:33:03: ISAKMP cookie 3123100B 0E294692
04:33:03: ISAKMP cookie gen for src 10.1.1.1 dst 172.18.1.1
04:33:03: ISAKMP cookie AA8F7B41 091A7695
04:33:03: ISAKMP:          isadb_post_process_list: crawler: B 27FF 2 (6482B354)
04:33:03:          crawler my_cookie AA8F7B41 F7ACF384
04:33:03:          crawler his_cookie E46E088D F227FE4D
04:33:03: ISAKMP (0:13): received packet from 10.1.1.1 dport 500 sport 500 Global (R)
CONF_XAUTH
04:33:03: ISAKMP: hash from 7292D74 for 92 bytes
04:33:03: ISAKMP: Packet hash:
64218CC0:          84A1AF24 5D92B116          .!/$].1.
64218CD0: FC2C6252 A472C5F8 152AC860 63          |,br$rEx.*H`c
04:33:03: ISAKMP (0:13): processing transaction payload from 11.1.1.1. message ID =
-1447732198
04:33:03: ISAKMP: Config payload REPLY
04:33:03: ISAKMP/xauth: reply attribute XAUTH_USER_NAME_V2
04:33:03: ISAKMP/xauth: reply attribute XAUTH_USER_PASSWORD_V2
04:33:03: ISAKMP (0:13): deleting node -1447732198 error FALSE reason "done with xauth
request/reply exchange"
04:33:03: ISAKMP (0:13): Input = IKE_MSG_FROM_PEER, IKE_CFG_REPLY
04:33:03: ISAKMP (0:13): Old State = IKE_XAUTH_REQ_SENT New State =
IKE_XAUTH_AAA_CONT_LOGIN_AWAIT
04:33:03: ISAKMP cookie gen for src 10.1.1.1 dst 172.18.1.1
04:33:03: ISAKMP cookie AA8F7B41 A1B3E684
04:33:03: ISAKMP:          isadb_post_process_list: crawler: B 27FF 12 (6482B354)
04:33:03:          crawler my_cookie AA8F7B41 F7ACF384
04:33:03:          crawler his_cookie E46E088D F227FE4D
04:33:03: ISAKMP: got callback 1
04:33:03: ISAKMP: set new node 524716665 to CONF_XAUTH
04:33:03: ISAKMP (0:13): initiating peer config to 10.1.1.1. ID = 524716665
04:33:03: ISAKMP (0:13): sending packet to 10.1.1.1 my_port 500 peer_port 500 (R) CONF_XAUTH

04:33:03: ISAKMP (0:13): Input = IKE_MSG_FROM_AAA, IKE_AAA_CONT_LOGIN
04:33:03: ISAKMP (0:13): Old State = IKE_XAUTH_AAA_CONT_LOGIN_AWAIT New State =
IKE_XAUTH_SET_SENT
004:33:03: ISAKMP cookie gen for src 172.18.1.1 dst 10.1.1.1
04:33:03: ISAKMP cookie 3123100B 5C83A09D
04:33:03: ISAKMP cookie gen for src 10.1.1.1 dst 172.18.1.1
04:33:03: ISAKMP cookie AA8F7B41 2BEBEFD4
04:33:03: ISAKMP:          isadb_post_process_list: crawler: B 27FF 2 (6482B354)
04:33:03:          crawler my_cookie AA8F7B41 F7ACF384
04:33:03:          crawler his_cookie E46E088D F227FE4D
04:33:03: ISAKMP cookie gen for src 172.18.1.1 dst 10.1.1.1
04:33:03: ISAKMP cookie 3123100B DA00A46B
04:33:03: ISAKMP cookie gen for src 10.1.1.1 dst 172.18.1.1
04:33:03: ISAKMP cookie AA8F7B41 FDD27773
04:33:03: ISAKMP:          isadb_post_process_list: crawler: B 27FF 2 (6482B354)
04:33:03:          crawler my_cookie AA8F7B41 F7ACF384
04:33:03:          crawler his_cookie E46E088D F227FE4D
04:33:03: ISAKMP (0:13): received packet from 10.1.1.1 dport 500 sport 500 Global (R)
CONF_XAUTH
04:33:03: ISAKMP: hash from 7292A34 for 68 bytes
04:33:03: ISAKMP: Packet hash:
64218CC0:          5034B99E B8BA531F          P49.8:S.
64218CD0: 6267B8BD F3006989 DC118796 63          bg8=s.i.\...c
04:33:03: ISAKMP (0:13): processing transaction payload from 11.1.1.1. message ID = 524716665
04:33:03: ISAKMP: Config payload ACK
04:33:03: ISAKMP (0:13):          XAUTH ACK Processed
04:33:03: ISAKMP (0:13): deleting node 524716665 error FALSE reason "done with transaction"
04:33:03: ISAKMP (0:13): Input = IKE_MSG_FROM_PEER, IKE_CFG_ACK
04:33:03: ISAKMP (0:13): Old State = IKE_XAUTH_SET_SENT New State = IKE_P1_COMPLETE
04:33:03: ISAKMP cookie gen for src 10.1.1.1 dst 172.18.1.1
04:33:03: ISAKMP cookie AA8F7B41 E0BB50E9
04:33:03: ISAKMP:          isadb_post_process_list: crawler: 9 27FF 2 (6482B354)

```

```

04:33:03: crawler my_cookie AA8F7B41 F7ACF384
04:33:03: crawler his_cookie E46E088D F227FE4D
04:33:03: ISAKMP (0:13): Input = IKE_MSG_INTERNAL, IKE_PHASE1_COMPLETE
04:33:03: ISAKMP (0:13): Old State = IKE_P1_COMPLETE New State = IKE_P1_COMPLETE
04:33:03: ISAKMP cookie gen for src 172.18.1.1 dst 10.1.1.1
04:33:03: ISAKMP cookie 3123100B 7794EF6E
04:33:03: ISAKMP cookie gen for src 10.1.1.1 dst 172.18.1.1
04:33:03: ISAKMP cookie AA8F7B41 C035AAE5
04:33:03: ISAKMP: isadb_post_process_list: crawler: 9 27FF 2 (6482B354)
04:33:03: crawler my_cookie AA8F7B41 F7ACF384
04:33:03: crawler his_cookie E46E088D F227FE4D
04:33:03: ISAKMP cookie gen for src 172.18.1.1 dst 10.1.1.1
04:33:03: ISAKMP cookie 3123100B F1FCC25A
04:33:03: ISAKMP cookie gen for src 10.1.1.1 dst 172.18.1.1
04:33:03: ISAKMP cookie AA8F7B41 31744F44
04:33:03: ISAKMP: isadb_post_process_list: crawler: 9 27FF 2 (6482B354)
04:33:03: crawler my_cookie AA8F7B41 F7ACF384
04:33:03: crawler his_cookie E46E088D F207FE4D
04:33:03: ISAKMP (0:13): received packet from 10.1.1.1 dport 500 sport 500 Global (R) QM_IDLE

04:33:03: ISAKMP: set new node -1639992295 to QM_IDLE
04:33:03: ISAKMP: hash from 7293A74 for 100 bytes
04:33:03: ISAKMP: Packet hash:
64218CC0: 9D7DF4DF FE3A6403 .}t~:d.
64218CD0: 3F1D1C59 C5D138CE 50289B79 07 ?..YEQ8NP(.y.
04:33:03: ISAKMP (0:13): processing transaction payload from 10.1.1.1. message ID =
-1639992295
04:33:03: ISAKMP: Config payload REQUEST
04:33:03: ISAKMP (0:13): checking request:
04:33:03: ISAKMP: IP4_ADDRESS
04:33:03: ISAKMP: IP4_NETMASK
04:33:03: ISAKMP: IP4_DNS
04:33:03: ISAKMP: IP4_DNS
04:33:03: ISAKMP: IP4_NBNS
04:33:03: ISAKMP: IP4_NBNS
04:33:03: ISAKMP: SPLIT_INCLUDE
04:33:03: ISAKMP: DEFAULT_DOMAIN
04:33:03: ISAKMP (0:13): Input = IKE_MSG_FROM_PEER, IKE_CFG_REQUEST
04:33:03: ISAKMP (0:13): Old State = IKE_P1_COMPLETE New State = IKE_CONFIG_AUTHOR_AAA_AWAIT

04:33:03: ISAKMP cookie gen for src 10.1.1.1 dst 172.18.1.1
04:33:03: ISAKMP cookie AA8F7B41 B02E0D67
04:33:03: ISAKMP: isadb_post_process_list: crawler: C 27FF 12 (6482B354)
04:33:03: crawler my_cookie AA8F7B41 F7ACF384
04:33:03: crawler his_cookie E46E088D F227FE4D
04:33:03: ISAKMP: got callback 1
04:33:03: ISAKMP (0:13): attributes sent in message:
04:33:03: Address: 10.2.0.0
04:33:03: ISAKMP (0:13): allocating address 10.4.1.4
04:33:03: ISAKMP: Sending private address: 10.4.1.4
04:33:03: ISAKMP: Sending DEFAULT_DOMAIN default domain name: vpn2.com
04:33:03: ISAKMP (0:13): responding to peer config from 10.1.1.1. ID = -1639992295
04:33:03: ISAKMP (0:13): sending packet to 10.1.1.1 my_port 500 peer_port 500 (R) CONF_ADDR

04:33:03: ISAKMP (0:13): deleting node -1639992295 error FALSE reason ""
04:33:03: ISAKMP (0:13): Input = IKE_MSG_FROM_AAA, IKE_AAA_GROUP_ATTR
04:33:03: ISAKMP (0:13): Old State = IKE_CONFIG_AUTHOR_AAA_AWAIT New State = IKE_P1_COMPLETE

04:33:03: ISAKMP cookie gen for src 172.18.1.1 dst 10.1.1.1
04:33:03: ISAKMP cookie 3123100B 881D5411
04:33:03: ISAKMP cookie gen for src 11.1.1.1 dst 172.18.1.1
04:33:03: ISAKMP cookie AA8F7B41 6FD82541
04:33:03: ISAKMP: isadb_post_process_list: crawler: 9 27FF 2 (6482B354)
04:33:03: crawler my_cookie AA8F7B41 F7ACF384

```

```

04:33:03: crawler his_cookie E46E088D F227FE4D
04:33:03: ISAKMP cookie gen for src 172.18.1.1 dst 10.1.1.1
04:33:03: ISAKMP cookie 3123100B 8A94C1BE
04:33:03: ISAKMP cookie gen for src 10.1.1.1 dst 172.18.1.1
04:33:03: ISAKMP cookie AA8F7B41 F3BA766D
04:33:03: ISAKMP: isadb_post_process_list: crawler: 9 27FF 2 (6482B354)
04:33:03: crawler my_cookie AA8F7B41 F7ACF384
04:33:03: crawler his_cookie E46E088D F207FE4D
04:33:03: ISAKMP (0:13): received packet from 10.1.1.1 dport 500 sport 500 Global (R) QM_IDLE

04:33:03: ISAKMP: set new node 17011691 to QM_IDLE
04:33:03: ISAKMP: hash from 70029F4 for 540 bytes
04:33:03: ISAKMP: Packet hash:
64218CC0: AFBA30B2 55F5BC2D /:02Uu<-
64218CD0: 3A86B1C9 00D2F5BA 77BF5589 07 :.lI.Ru:w?U..
04:33:03: ISAKMP (0:13): processing HASH payload. message ID = 17011691
04:33:03: ISAKMP (0:13): processing SA payload. message ID = 17011691
04:33:03: ISAKMP (0:13): Checking IPsec proposal 1
04:33:03: ISAKMP: transform 1, ESP_AES
04:33:03: ISAKMP: attributes in transform:
04:33:03: ISAKMP: encaps is 1
04:33:03: ISAKMP: SA life type in seconds
04:33:03: ISAKMP: SA life duration (VPI) of 0x0 0x20 0xC4 0x9B
04:33:03: ISAKMP: SA life type in kilobytes
04:33:03: ISAKMP: SA life duration (VPI) of 0x0 0x46 0x50 0x0
04:33:03: ISAKMP: authenticator is HMAC-SHA
04:33:03: ISAKMP (0:13): atts are acceptable.
04:33:03: IPSEC(validate_proposal_request): proposal part #1,
(key eng. msg.) INBOUND local= 172.18.1.1, remote= 10.1.1.1,
local_proxy= 0.0.0.0/0.0.0.0/0/0 (type=4),
remote_proxy= 10.4.1.4/255.255.255.255/0/0 (type=1),
protocol= ESP, transform= esp-aes esp-sha-hmac,
lifedur= 0s and 0kb,
spi= 0x0(0), conn_id= 0, keysize= 0, flags= 0x2
04:33:03: IPSEC(kei_proxy): head = ra, map->ivrf = vpn1, kei->ivrf = vpn2
04:33:03: IPSEC(kei_proxy): head = ra, map->ivrf = vpn2, kei->ivrf = vpn2
04:33:03: IPSEC(validate_transform_proposal): transform proposal not supported for identity:
{esp-aes esp-sha-hmac}
04:33:03: ISAKMP (0:13): IPsec policy invalidated proposal
04:33:03: ISAKMP (0:13): Checking IPsec proposal 2
04:33:03: ISAKMP: transform 1, ESP_AES
04:33:03: ISAKMP: attributes in transform:
04:33:03: ISAKMP: encaps is 1
04:33:03: ISAKMP: SA life type in seconds
04:33:03: ISAKMP: SA life duration (VPI) of 0x0 0x20 0xC4 0x9B
04:33:03: ISAKMP: SA life type in kilobytes
04:33:03: ISAKMP: SA life duration (VPI) of 0x0 0x46 0x50 0x0
04:33:03: ISAKMP: authenticator is HMAC-SHA
04:33:03: ISAKMP (0:13): atts are acceptable.
04:33:03: IPSEC(validate_proposal_request): proposal part #1,
(key eng. msg.) INBOUND local= 172.18.1.1, remote= 10.1.1.1,
local_proxy= 0.0.0.0/0.0.0.0/0/0 (type=4),
remote_proxy= 10.4.1.4/255.255.255.255/0/0 (type=1),
protocol= ESP, transform= esp-aes esp-sha-hmac,
lifedur= 0s and 0kb,
spi= 0x0(0), conn_id= 0, keysize= 0, flags= 0x2
04:33:03: IPSEC(kei_proxy): head = ra, map->ivrf = vpn1, kei->ivrf = vpn2
04:33:03: IPSEC(kei_proxy): head = ra, map->ivrf = vpn2, kei->ivrf = vpn2
04:33:03: ISAKMP (0:13): processing NONCE payload. message ID = 17011691
04:33:03: ISAKMP (0:13): processing ID payload. message ID = 17011691
04:33:03: ISAKMP (0:13): processing ID payload. message ID = 17011691
04:33:03: ISAKMP (0:13): asking for 1 spis from ipsec
04:33:03: ISAKMP (0:13): Node 17011691, Input = IKE_MSG_FROM_PEER, IKE_QM_EXCH

```

```

04:33:03: ISAKMP (0:13): Old State = IKE_QM_READY New State = IKE_QM_SPI_STARVE
04:33:03: IPSEC(key_engine): got a queue event...
04:33:03: IPSEC(spi_response): getting spi 2749516541 for SA
    from 172.18.1.1 to 10.1.1.1 for prot 3
04:33:03: ISAKMP: received ke message (2/1)
04:33:04: ISAKMP (13): ID payload
    next-payload : 5
    type          : 1
    addr          : 10.4.1.4
    protocol     : 0
    port         : 0
04:33:04: ISAKMP (13): ID payload
    next-payload : 11
    type          : 4
    addr          : 0.0.0.0
    protocol     : 0
    port         : 0
04:33:04: ISAKMP (0:13): sending packet to 10.1.1.1 my_port 500 peer_port 500 (R) QM_IDLE

04:33:04: ISAKMP (0:13): Node 17011691, Input = IKE_MESG_FROM_IPSEC, IKE_SPI_REPLY
04:33:04: ISAKMP (0:13): Old State = IKE_QM_SPI_STARVE New State = IKE_QM_R_QM2
04:33:04: ISAKMP cookie gen for src 172.18.1.1 dst 10.1.1.1
04:33:04: ISAKMP cookie 3123100B 93DE46D2
04:33:04: ISAKMP cookie gen for src 10.1.1.1 dst 172.18.1.1
04:33:04: ISAKMP cookie AA8F7B41 088A0A16
04:33:04: ISAKMP:      isadb_post_process_list: crawler: 9 27FF 2 (6482B354)
04:33:04:      crawler my_cookie AA8F7B41 F7ACF384
04:33:04:      crawler his_cookie E46E088D F227FE4D
04:33:04: ISAKMP cookie gen for src 172.18.1.1 dst 10.1.1.1
04:33:04: ISAKMP cookie 3123100B A8F23F73
04:33:04: ISAKMP cookie gen for src 10.1.1.1 dst 172.18.1.1
04:33:04: ISAKMP cookie AA8F7B41 93D8D879
04:33:04: ISAKMP:      isadb_post_process_list: crawler: 9 27FF 2 (6482B354)
04:33:04:      crawler my_cookie AA8F7B41 F7ACF384
04:33:04:      crawler his_cookie E46E088D F227FE4D
04:33:04: ISAKMP (0:13): received packet from 10.1.1.1 dport 500 sport 500 Global (R) QM_IDLE

04:33:04: ISAKMP: hash from 7290DB4 for 60 bytes
04:33:04: ISAKMP: Packet hash:
64218CC0:      4BB45A92 7181A2F8      K4Z.q."x
64218CD0: 73CC12F8 091875C0 054F77CD 63      sL.x..u@.OwMc
04:33:04: ISAKMP: Locking peer struct 0x640BBB18, IPSEC refcount 1 for stuff_ke
04:33:04: ISAKMP (0:13): Creating IPsec SAs
04:33:04:      inbound SA from 10.1.1.1 to 172.18.1.1 (f/i) 0/ 2
    (proxy 10.4.1.4 to 0.0.0.0)
04:33:04:      has spi 0xA3E24AFD and conn_id 5127 and flags 2
04:33:04:      lifetime of 2147483 seconds
04:33:04:      lifetime of 4608000 kilobytes
04:33:04:      has client flags 0x0
04:33:04:      outbound SA from 172.18.1.1 to 10.1.1.1 (f/i) 0/ 2 (proxy
0.0.0.0 to 10.4.1.4 )
04:33:04:      has spi 1343294712 and conn_id 5128 and flags A
04:33:04:      lifetime of 2147483 seconds
04:33:04:      lifetime of 4608000 kilobytes
04:33:04:      has client flags 0x0
04:33:04: ISAKMP (0:13): deleting node 17011691 error FALSE reason "quick mode done (await)"
04:33:04: ISAKMP (0:13): Node 17011691, Input = IKE_MESG_FROM_PEER, IKE_QM_EXCH
04:33:04: ISAKMP (0:13): Old State = IKE_QM_R_QM2 New State = IKE_QM_PHASE2_COMPLETE
04:33:04: IPSEC(key_engine): got a queue event...
04:33:04: IPSEC(initialize_sas): ,
    (key eng. msg.) INBOUND local= 172.18.1.1, remote= 10.1.1.1,
    local_proxy= 0.0.0.0/0.0.0.0/0/0 (type=4),
    remote_proxy= 10.4.1.4/0.0.0.0/0/0 (type=1),
    protocol= ESP, transform= esp-aes esp-sha-hmac ,

```

```

    lifedur= 2147483s and 4608000kb,
    spi= 0xA3E24AFD(2749516541), conn_id= 5127, keysize= 0, flags= 0x2
04:33:04: IPSEC(initialize_sas): ,
    (key eng. msg.) OUTBOUND local= 172.18.1.1, remote= 10.1.1.1,
    local_proxy= 0.0.0.0/0.0.0.0/0/0 (type=4),
    remote_proxy= 10.4.1.4/0.0.0.0/0/0 (type=1),
    protocol= ESP, transform= esp-aes esp-sha-hmac,
    lifedur= 2147483s and 4608000kb,
    spi= 0x50110CF8(1343294712), conn_id= 5128, keysize= 0, flags= 0xA
04:33:04: IPSEC(kei_proxy): head = ra, map->ivrf = vpn1, kei->ivrf = vpn2
04:33:04: IPSEC(kei_proxy): head = ra, map->ivrf = vpn2, kei->ivrf = vpn2
04:33:04: IPSEC(rte_mgr): VPN Route Added 10.4.1.4 255.255.255.255 via 10.1.1.1 in vpn2
04:33:04: IPSEC(add mtree): src 0.0.0.0, dest 10.4.1.4, dest_port 0
04:33:04: IPSEC(create_sa): sa created,
    (sa) sa_dest= 172.18.1.1, sa_prot= 50,
    sa_spi= 0xA3E24AFD(2749516541),
    sa_trans= esp-aes esp-sha-hmac, sa_conn_id= 5127
04:33:04: IPSEC(create_sa): sa created,
    (sa) sa_dest= 10.1.1.1, sa_prot= 50,
    sa_spi= 0x50110CF8(1343294712),
    sa_trans= esp-aes esp-sha-hmac, sa_conn_id= 5128
04:33:53: ISAKMP (0:13): purging node -1639992295
04:33:54: ISAKMP (0:13): purging node 17011691

```

## Configuration Examples for VRF-Aware IPsec

### Example Static IPsec-to-MPLS VPN

The following sample shows a static configuration that maps IPsec tunnels to MPLS VPNs. The configurations map IPsec tunnels to MPLS VPNs “VPN1” and “VPN2.” Both of the IPsec tunnels terminate on a single public-facing interface.

#### IPsec PE Configuration

```

ip vrf vpn1
 rd 100:1
  route-target export 100:1
  route-target import 100:1
!
ip vrf vpn2
 rd 101:1
  route-target export 101:1
  route-target import 101:1
!
crypto keyring vpn1
 pre-shared-key address 172.16.1.1 key vpn1
crypto keyring vpn2
 pre-shared-key address 10.1.1.1 key vpn2
!
crypto isakmp policy 1
 encr aes
 authentication pre-share
 group 14
!
crypto isakmp profile vpn1
 vrf vpn1
 keyring vpn1
 match identity address 172.16.1.1 255.255.255.255

```

```

!
crypto isakmp profile vpn2
  vrf vpn2
  keyring vpn2
  match identity address 10.1.1.1 255.255.255.255
!
crypto ipsec transform-set vpn1 esp-aes esp-sha-hmac
crypto ipsec transform-set vpn2 esp-aes esp-sha-hmac
!
crypto map crypmap 1 ipsec-isakmp
  set peer 172.16.1.1
  set transform-set vpn1
  set isakmp-profile vpn1
  match address 101
crypto map crypmap 3 ipsec-isakmp
  set peer 10.1.1.1
  set transform-set vpn2
  set isakmp-profile vpn2
  match address 102
!
interface Ethernet1/1
  ip address 172.17.1.1 255.255.0.0
  tag-switching ip
!
interface Ethernet1/2
  ip address 172.18.1.1 255.255.255.0
  crypto map crypmap
!
ip route 172.16.1.1 255.255.255.255 172.18.1.2
ip route 10.1.1.1 255.255.255.255 172.18.1.2
ip route vrf vpn1 10.2.0.0 255.255.0.0 172.18.1.2 global
ip route vrf vpn2 10.2.0.0 255.255.0.0 172.18.1.2 global
!
access-list 101 permit ip 10.1.0.0 0.0.255.255 10.2.0.0 0.0.255.255
access-list 102 permit ip 10.1.0.0 0.0.255.255 10.2.0.0 0.0.255.255

```

### IPsec Customer Provided Edge (CPE) Configuration for VPN1

```

crypto isakmp policy 1
  encr aes
  authentication pre-share
  group 14
crypto isakmp key vpn1 address 172.18.1.1
!
!
crypto ipsec transform-set vpn1 esp-aes esp-sha-hmac
!
crypto map vpn1 1 ipsec-isakmp
  set peer 172.18.1.1
  set transform-set vpn1
  match address 101
!
interface FastEthernet1/0
  ip address 172.16.1.1 255.255.255.0
  crypto map vpn1
!
interface FastEthernet1/1
  ip address 10.2.1.1 255.255.0.0
!
access-list 101 permit ip 10.2.0.0 0.0.255.255 10.1.0.0 0.0.255.255
!

```



**IPsec CPE Configuration for VPN2**

```

crypto isakmp policy 1
  encr aes
  authentication pre-share
  group 14
!
crypto isakmp key vpn2 address 172.18.1.1
!
!
crypto ipsec transform-set vpn2 esp-aes esp-sha-hmac
!
crypto map vpn2 1 ipsec-isakmp
  set peer 172.18.1.1
  set transform-set vpn2
  match address 101
!
interface FastEthernet0
  ip address 10.1.1.1 255.255.255.0
  crypto map vpn2
!
interface FastEthernet1
  ip address 10.2.1.1 255.255.0.0
!
access-list 101 permit ip 10.2.0.0 0.0.255.255 10.1.0.0 0.0.255.255

```

**Example IPsec-to-MPLS VPN Using RSA Encryption**

The following example shows an IPsec-to-MPLS configuration using RSA encryption:

**PE Router Configuration**

```

ip vrf vpn1
  rd 100:1
  route-target export 100:1
  route-target import 100:1
!
crypto isakmp policy 10
  authentication rsa-encr
!
crypto keyring vpn1
  rsa-pubkey address 172.16.1.1 encryption
  key-string
    305C300D 06092A86 4886F70D 01010105 00034B00 30480241 00DBF381 00DDECC8
    DC4AA490 40320C52 9912D876 EB36717C 63DCA95C 7E5EC02A 84F276CE 292B42D7
    D664F324 3726F4E0 39D33093 ECB81B95 482511A5 F064C4B3 D5020301 0001
  quit
!
crypto isakmp profile vpn1
  vrf vpn1
  keyring vpn1
  match identity address 172.16.1.1 255.255.255.255
!
crypto ipsec transform-set vpn1 esp-aes esp-sha-hmac
!
crypto map crypmap 1 ipsec-isakmp
  set peer 172.16.1.1
  set transform-set vpn1
  set isakmp-profile vpn1
  match address 101

```

```

!
interface Ethernet1/1
 ip address 172.17.1.1 255.255.0.0
 tag-switching ip
!
interface Ethernet1/2
 ip address 172.18.1.1 255.255.255.0
 crypto map crypmap
!
ip route 172.16.1.1 255.255.255.255 172.18.1.2
ip route vrf vpn1 10.2.0.0 255.255.0.0 172.18.1.2 global
!
access-list 101 permit ip 10.1.0.0 0.0.255.255 10.2.0.0 0.0.255.255

```

### IPsec CPE Configuration for VPN1

```

crypto isakmp policy 10
 authentication rsa-encr
!
crypto key pubkey-chain rsa
 addressed-key 172.18.1.1 encryption
 key-string
 3082011B 300D0609 2A864886 F70D0101 01050003 82010800 30820103 0281FB00
 C90CC78A 6002BDBA 24683396 B7D7877C 16D08C47 E00C3C10 63CF13BC 4E09EA23
 92EB8A48 4113F5A4 8796C8BE AD7E2DC1 3B0742B6 7118CE7C 1B0E21D1 AA9724A4
 4D74FCEA 562FF225 A2B11F18 E53C4415 61C3B741 3A06E75D B4F9102D 6163EE40
 16C68FD7 6532F660 97B59118 9C8DE3E5 4E2F2925 BBB87FCB 95223D4E A5E362DB
 215CB35C 260080805 17BBE1EF C3050E13 031F3D5B 5C22D16C FC8B1EC5 074F07A5
 D050EC80 7890D9C5 EC20D6F0 173FE2BA 89F5B5F9 2EADC9A6 D461921E 3D5B60016
 ABB8B6B9 E2124A21 93F0E4AE B487461B E7F1F1C4 032A0B0E 80DC3E15 CB268EC9
 5D76B9BD 3C78CB75 CE9F68C6 484D6573 CBC3EB59 4B5F3999 8F9D0203 010001
 quit
!
crypto ipsec transform-set vpn1 esp-aes esp-sha-hmac
!
crypto map vpn1 1 ipsec-isakmp
 set peer 172.18.1.1
 set transform-set vpn1
 match address 101
!
interface FastEthernet1/0
 ip address 172.16.1.1 255.255.255.0
 crypto map vpn1
!
interface FastEthernet1/1
 ip address 10.2.1.1 255.255.0.0
!
access-list 101 permit ip 10.2.0.0 0.0.255.255 10.1.0.0 0.0.255.255
!

```

## Example IPsec-to-MPLS VPN with RSA Signatures

The following shows an IPsec-to-MPLS VPN configuration using RSA signatures:

### PE Router Configuration

```

ip vrf vpn1
 rd 100:1
 route-target export 100:1
 route-target import 100:1

```

```

!
crypto ca trustpoint bombo
  enrollment url http://172.31.68.59:80
  crl optional
!
crypto ca certificate chain bombo
  certificate 03C0
  308203BF 308202A7 A0030201 02020203 C0300D06 092A8648 86F70D01 01050500
  . . .
  quit
  certificate ca 01
  30820379 30820261 A0030201 02020101 300D0609 2A864886 F70D0101 05050030
  . . .
  quit
!
crypto isakmp profile vpn1
  vrf vpn1
  ca trust-point bombo
  match identity address 172.16.1.1 255.255.255.255
!
crypto ipsec transform-set vpn1 esp-aes esp-sha-hmac
!
crypto map crypmap 1 ipsec-isakmp
  set peer 172.16.1.1
  set transform-set vpn1
  set isakmp-profile vpn1
  match address 101
!
interface Ethernet1/1
  ip address 172.31.1.1 255.255.0.0
  tag-switching ip
!
interface Ethernet1/2
  ip address 172.18.1.1 255.255.255.0
  crypto map crypmap
!
ip route 172.16.1.1 255.255.255.255 172.18.1.2
ip route vrf vpn1 10.2.0.0 255.255.0.0 172.18.1.2 global
!
access-list 101 permit ip 10.1.0.0 0.0.255.255 10.2.0.0 0.0.255.255
!

```

### IPsec CPE Configuration for VPN1

```

crypto ca trustpoint bombo
  enrollment url http://172.31.68.59:80
  crl optional
!
crypto ca certificate chain bombo
  certificate 03BF
  308203BD 308202A5 A0030201 02020203 BF300D06 092A8648 86F70D01 01050500
  . . .
  quit
  certificate ca 01
  30820379 30820261 A0030201 02020101 300D0609 2A864886 F70D0101 05050030
  . . .
  quit
!
crypto ipsec transform-set vpn1 esp-aes esp-sha-hmac
!
crypto map vpn1 1 ipsec-isakmp
  set peer 172.18.1.1
  set transform-set vpn1

```

```

    match address 101
    !
interface FastEthernet1/0
 ip address 172.16.1.1 255.255.255.0
 crypto map vpn1
 !
interface FastEthernet1/1
 ip address 10.2.1.1 255.255.0.0
 !
access-list 101 permit ip 10.2.0.0 0.0.255.255 10.1.0.0 0.0.255.255
 !

```

## Example IPsec Remote Access-to-MPLS VPN

The following shows an IPsec remote access-to-MPLS VPN configuration. The configuration maps IPsec tunnels to MPLS VPNs. The IPsec tunnels terminate on a single public-facing interface.

### PE Router Configuration

```

aaa new-model
!
aaa group server radius vpn1
 server-private 10.1.1.1 auth-port 1645 acct-port 1646 timeout 5 retransmit 3 key vpn1
!
aaa group server radius vpn2
 server-private 10.1.1.1 auth-port 1645 acct-port 1646 timeout 5 retransmit 3 key vpn2
!
aaa authorization network aaa-list group radius
!
ip vrf vpn1
 rd 100:1
 route-target export 100:1
 route-target import 100:1
!
ip vrf vpn2
 rd 101:1
 route-target export 101:1
 route-target import 101:1
!
crypto isakmp profile vpn1-ra
 vrf vpn1
 match identity group vpn1-ra
 client authentication list vpn1
 isakmp authorization list aaa-list
 client configuration address initiate
 client configuration address respond
crypto isakmp profile vpn2-ra
 vrf vpn2
 match identity group vpn2-ra
 client authentication list vpn2
 isakmp authorization list aaa-list
 client configuration address initiate
 client configuration address respond
!
!
crypto ipsec transform-set vpn1 esp-aes esp-sha-hmac
crypto ipsec transform-set vpn2 esp-aes esp-sha-hmac
!
crypto dynamic-map vpn1 1
 set transform-set vpn1
 set isakmp-profile vpn1-ra

```

```

reverse-route
!
crypto dynamic-map vpn2 1
set transform-set vpn2
set isakmp-profile vpn2-ra
reverse-route
!
!
crypto map ra 1 ipsec-isakmp dynamic vpn1
crypto map ra 2 ipsec-isakmp dynamic vpn2
!
interface Ethernet1/1
ip address 172.17.1.1 255.255.0.0
tag-switching ip
!
interface Ethernet1/2
ip address 172.18.1.1 255.255.255.0
crypto map ra
!
ip local pool vpn1-ra 10.4.1.1 10.4.1.254 group vpn1-ra
ip local pool vpn2-ra 10.4.1.1 10.4.1.254 group vpn2-ra
!

```

## Upgrade from Previous Versions of the Cisco Network-Based IPsec VPN Solution

The VRF-Aware IPsec feature in the Cisco network-based IPsec VPN solution release 1.5 requires that you change your existing configurations. The following sample configurations indicate the changes you must make to your existing configurations.

### Site-to-Site Configuration Upgrade

The following configurations show the changes that are necessary for a site-to-site configuration upgrade from a previous version of the network-based IPsec VPN solution to the Cisco network-based IPsec VPN solution release 1.5:

#### Previous Version Site-to-Site Configuration

```

crypto isakmp key VPN1 address 172.21.25.74
crypto isakmp key VPN2 address 172.21.21.74
!
crypto ipsec transform-set VPN1 esp-aes esp-sha-hmac
crypto ipsec transform-set VPN2 esp-aes esp-sha-hmac
!
crypto map VPN1 10 ipsec-isakmp
set peer 172.21.25.74
set transform-set VPN1
match address 101
!
crypto map VPN2 10 ipsec-isakmp
set peer 172.21.21.74
set transform-set VPN2
match address 102
!
interface FastEthernet0/0.1
encapsulation dot1Q 1 native
ip vrf forwarding VPN1
ip address 172.21.25.73 255.255.255.0

```

```

crypto map VPN1
!
interface FastEthernet0/0.2
 encapsulation dot1Q 2 native
 ip vrf forwarding VPN2
 ip address 172.21.21.74 255.255.255.0
 crypto map VPN2

```

## New Version Site-to-Site Configuration

The following is an upgraded version of the same site-to-site configuration to the Cisco network-based IPsec VPN solution release 1.5 solution:



**Note** You must change two keyrings. The VRF-Aware Upset feature requires that keys be associated with a VRF if the IKE local endpoint is in the VRF.

```

crypto keyring VPN1-KEYS vrf VPN1
pre-shared-key address 172.21.25.74 key VPN1
!
crypto keyring VPN2-KEYS vrf VPN2
pre-shared-key address 172.21.21.74 key VPN2
!
crypto ipsec transform-set VPN1 esp-aes esp-sha-hmac
crypto ipsec transform-set VPN2 esp-aes esp-sha-hmac
!
crypto map VPN1 10 ipsec-isakmp
set peer 172.21.25.74
set transform-set VPN1
match address 101
!
crypto map VPN2 10 ipsec-isakmp
set peer 172.21.21.74
set transform-set VPN2
match address 102
!
interface FastEthernet0/0.1
 encapsulation dot1Q 1 native
 ip vrf forwarding VPN1
 ip address 172.21.25.73 255.255.255.0
 crypto map VPN1
!
interface FastEthernet0/0.2
 encapsulation dot1Q 2 native
 ip vrf forwarding VPN2
 ip address 172.21.21.74 255.255.255.0
 crypto map VPN2

```

## Remote Access Configuration Upgrade

The following configurations show the changes that are necessary for a remote access configuration upgrade from a previous version of the network-based IPsec VPN solution to the Cisco network-based IPsec VPN solution release 1.5:

### Previous Version Remote Access Configuration

```

crypto isakmp client configuration group VPN1-RA-GROUP
key VPN1-RA

```

```

pool VPN1-RA
!
crypto isakmp client configuration group VPN2-RA-GROUP
key VPN2-RA
pool VPN2-RA
!
crypto ipsec transform-set VPN1-RA esp-aes esp-sha-hmac
crypto ipsec transform-set VPN2-RA esp-aes esp-sha-hmac
!
crypto dynamic-map VPN1-RA 1
  set transform-set VPN1-RA
reverse-route
!
crypto dynamic-map VPN2-RA 1
  set transform-set VPN2-RA
reverse-route
!
!
crypto map VPN1 client authentication list VPN1-RA-LIST
crypto map VPN1 isakmp authorization list VPN1-RA-LIST
crypto map VPN1 client configuration address initiate
crypto map VPN1 client configuration address respond
crypto map VPN1 10 ipsec-isakmp dynamic VPN1-RA
!
crypto map VPN2 client authentication list VPN2-RA-LIST
crypto map VPN2 isakmp authorization list VPN2-RA-LIST
crypto map VPN2 client configuration address initiate
crypto map VPN2 client configuration address respond
crypto map VPN2 10 ipsec-isakmp dynamic VPN2-RA
!
interface FastEthernet0/0.1
encapsulation dot1Q 1 native
ip vrf forwarding VPN1
ip address 172.21.25.73 255.255.255.0
crypto map VPN1
!
interface FastEthernet0/0.2
encapsulation dot1Q 2 native
ip vrf forwarding VPN2
ip address 172.21.21.74 255.255.255.0
crypto map VPN2

```

## New Version Remote Access Configuration

In the following instance, there is no upgrade; it is recommended that you change to the following configuration:

```

crypto isakmp client configuration group VPN1-RA-GROUP
  key VPN1-RA
  pool VPN1-RA
!
crypto isakmp client configuration group VPN2-RA-GROUP
  key VPN2-RA
  pool VPN2-RA
!
crypto isakmp profile VPN1-RA
  match identity group VPN1-RA-GROUP
  client authentication list VPN1-RA-LIST
  isakmp authorization list VPN1-RA-LIST
  client configuration address initiate
  client configuration address respond
!
crypto isakmp profile VPN2-RA
  match identity group VPN2-RA-GROUP

```

```

client authentication list VPN2-RA-LIST
isakmp authorization list VPN2-RA-LIST
client configuration address initiate
client configuration address respond
!
crypto ipsec transform-set VPN1-RA esp-aes esp-sha-hmac
crypto ipsec transform-set VPN2-RA esp-aes esp-sha-hmac
!
crypto dynamic-map VPN1-RA 1
set transform-set VPN1-RA
set isakmp-profile VPN1-RA
reverse-route
!
crypto dynamic-map VPN2-RA 1
set transform-set VPN2-RA
set isakmp-profile VPN2-RA
reverse-route
!
crypto map VPN1 10 ipsec-isakmp dynamic VPN1-RA
!
crypto map VPN2 10 ipsec-isakmp dynamic VPN2-RA
!
interface FastEthernet0/0.1
encapsulation dot1Q 1 native
ip vrf forwarding VPN1
ip address 172.21.25.73 255.255.255.0
crypto map VPN1
!
interface FastEthernet0/0.2
encapsulation dot1Q 2 native
ip vrf forwarding VPN2
ip address 172.21.21.74 255.255.255.0
crypto map VPN2

```

## Combination Site-to-Site and Remote Access Configuration Upgrade

The following configurations show the changes that are necessary for a site-to-site and remote access configuration upgrade from a previous version of the network-based IPsec VPN solution to the Cisco network-based IPsec VPN solution release 1.5:

### Previous Version Site-to-Site and Remote Access Configuration

```

crypto isakmp key VPN1 address 172.21.25.74 no-xauth
crypto isakmp key VPN2 address 172.21.21.74 no-xauth
!
crypto isakmp client configuration group VPN1-RA-GROUP
key VPN1-RA
pool VPN1-RA
!
crypto isakmp client configuration group VPN2-RA-GROUP
key VPN2-RA
pool VPN2-RA
!
crypto ipsec transform-set VPN1 esp-aes esp-sha-hmac
crypto ipsec transform-set VPN2 esp-aes esp-sha-hmac
!
crypto ipsec transform-set VPN1-RA esp-aes esp-sha-hmac
crypto ipsec transform-set VPN2-RA esp-aes esp-sha-hmac
!
crypto dynamic-map VPN1-RA 1
set transform-set VPN1-RA
reverse-route

```



```

!
crypto dynamic-map VPN2-RA 1
set transform-set VPN2-RA
reverse-route
!
crypto map VPN1 client authentication list VPN1-RA-LIST
crypto map VPN1 isakmp authorization list VPN1-RA-LIST
crypto map VPN1 client configuration address initiate
crypto map VPN1 client configuration address respond
crypto map VPN1 10 ipsec-isakmp
set peer 172.21.25.74
set transform-set VPN1
match address 101
crypto map VPN1 20 ipsec-isakmp dynamic VPN1-RA
!
crypto map VPN2 client authentication list VPN2-RA-LIST
crypto map VPN2 isakmp authorization list VPN2-RA-LIST
crypto map VPN2 client configuration address initiate
crypto map VPN2 client configuration address respond
crypto map VPN2 10 ipsec-isakmp
set peer 172.21.21.74
set transform-set VPN2
match address 102
crypto map VPN2 20 ipsec-isakmp dynamic VPN2-RA
!
interface FastEthernet0/0.1
encapsulation dot1Q 1 native
ip vrf forwarding VPN1
ip address 172.21.25.73 255.255.255.0
crypto map VPN1
!
interface FastEthernet0/0.2
encapsulation dot1Q 2 native
ip vrf forwarding VPN2
ip address 172.21.21.74 255.255.255.0
crypto map VPN2

```

## New Version Site-to-Site and Remote Access Configuration

You must upgrade to this configuration:



**Note** For site-to-site configurations that do not require XAUTH, configure an ISAKMP profile without XAUTH configuration. For remote access configurations that require XAUTH, configure an ISAKMP profile with XAUTH.

```

crypto keyring VPN1-KEYS vrf VPN1
pre-shared-key address 172.21.25.74 key VPN1
!
crypto keyring VPN2-KEYS vrf VPN2
pre-shared-key address 172.21.21.74 key VPN2
!
crypto isakmp client configuration group VPN1-RA-GROUP
key VPN1-RA
pool VPN1-RA
!
crypto isakmp client configuration group VPN2-RA-GROUP
key VPN2-RA
pool VPN2-RA
!

```

```

crypto isakmp profile VPN1
keyring VPN1-KEYS
match identity address 172.21.25.74 VPN1
!
crypto isakmp profile VPN2
keyring VPN2-KEYS
match identity address 172.21.21.74 VPN2
!
crypto isakmp profile VPN1-RA
match identity group VPN1-RA-GROUP
client authentication list VPN1-RA-LIST
isakmp authorization list VPN1-RA-LIST
client configuration address initiate
client configuration address respond
!
crypto isakmp profile VPN2-RA
match identity group VPN2-RA-GROUP
client authentication list VPN2-RA-LIST
isakmp authorization list VPN2-RA-LIST
client configuration address initiate
client configuration address respond
!
crypto ipsec transform-set VPN1 esp-aes esp-sha-hmac
crypto ipsec transform-set VPN2 esp-aes esp-sha-hmac
!
crypto ipsec transform-set VPN1-RA esp-aes esp-sha-hmac
crypto ipsec transform-set VPN2-RA esp-aes esp-sha-hmac
!
crypto dynamic-map VPN1-RA 1
set transform-set VPN1-RA
set isakmp-profile VPN1-RA
reverse-route
!
crypto dynamic-map VPN2-RA 1
set transform-set VPN2-RA
set isakmp-profile VPN2-RA
reverse-route
!
crypto map VPN1 10 ipsec-isakmp
set peer 172.21.25.74
set transform-set VPN1
set isakmp-profile VPN1
match address 101
crypto map VPN1 20 ipsec-isakmp dynamic VPN1-RA
!
crypto map VPN2 10 ipsec-isakmp
set peer 172.21.21.74
set transform-set VPN2
set isakmp-profile VPN2
match address 102
crypto map VPN2 20 ipsec-isakmp dynamic VPN2-RA
!
interface FastEthernet0/0.1
encapsulation dot1Q 1 native
ip vrf forwarding VPN1
ip address 172.21.25.73 255.255.255.0
crypto map VPN1
!
interface FastEthernet0/0.2
encapsulation dot1Q 2 native
ip vrf forwarding VPN2
ip address 172.21.21.74 255.255.255.0
crypto map VPN2

```

# Additional References

## Related Documents

Related Topic	Document Title
IPsec configuration tasks	“Configuring Security for VPNs with IPsec”
IPsec commands	<i>Cisco IOS Security Command Reference</i>
IKE Phase 1 and Phase 2, aggressive mode, and main mode	“Configuring Internet Key Exchange for IPsec VPNs”
IKE dead peer detection	“Easy VPN Server”
Recommended cryptographic algorithms	<a href="#">Next Generation Encryption</a>

## Standards

Standard	Title
None	--

## MIBs

MIB	MIBs Link
None	To locate and download MIBs for selected platforms, Cisco software releases, and feature sets, use Cisco MIB Locator found at the following URL:  <a href="http://www.cisco.com/go/mibs">http://www.cisco.com/go/mibs</a>

## RFCs

RFC	Title
None	--

## Technical Assistance

Description	Link
The Cisco Support and Documentation website provides online resources to download documentation, software, and tools. Use these resources to install and configure the software and to troubleshoot and resolve technical issues with Cisco products and technologies. Access to most tools on the Cisco Support and Documentation website requires a Cisco.com user ID and password.	<a href="http://www.cisco.com/cisco/web/support/index.html">http://www.cisco.com/cisco/web/support/index.html</a>

## Feature Information for VRF-Aware IPsec

The following table provides release information about the feature or features described in this module. This table lists only the software release that introduced support for a given feature in a given software release train. Unless noted otherwise, subsequent releases of that software release train also support that feature.

Use Cisco Feature Navigator to find information about platform support and Cisco software image support. To access Cisco Feature Navigator, go to [www.cisco.com/go/cfn](http://www.cisco.com/go/cfn). An account on Cisco.com is not required.

**Table 5: Feature Information for VRF-Aware IPsec**

Feature Name	Releases	Feature Information
VRF-Aware IPsec	12.2(15)T	<p>The VRF-Aware IPsec feature introduces IP Security (IPsec) tunnel mapping to Multiprotocol Label Switching (MPLS) Virtual Private Networks (VPNs). Using the VRF-Aware IPsec feature, you can map IPsec tunnels to Virtual Routing and Forwarding (VRF) instances using a single public-facing address.</p> <p>This feature was introduced in Cisco IOS Release 12.2(15)T.</p> <p>The following sections provide information about this feature:</p> <p>The following commands were introduced or modified: <b>address, ca trust-point, client authentication list, client configuration address, crypto isakmp profile, crypto keyring, crypto map isakmp-profile, initiate-mode, isakmp authorization list, keepalive (isakmp profile), keyring, key-string, match identity, no crypto xauth, pre-shared-key, quit, rsa-pubkey, self-identity, serial-number, set isakmp-profile, show crypto isakmp key, show crypto isakmp profile, vrf, clear crypto sa, crypto isakmp peer, crypto map isakmp-profile, show crypto dynamic-map, show crypto ipsec sa, show crypto isakmp sa, show crypto map (IPsec).</b></p>
	15.1(1)S	This feature was integrated into Cisco IOS Release 15.1(1)S.

## Glossary

**CA** --certification authority. CA is an entity that issues digital certificates (especially X.509 certificates) and vouches for the binding between the data items in a certificate.

**CLI** --command-line-interface. CLI is an interface that allows the user to interact with the operating system by entering commands and optional arguments. The UNIX operating system and DOS provide CLIs.

**client** --Corresponding IPsec IOS peer of the UUT in the Multi Protocol Label Switching (MPLS) network.

**dead peer** --IKE peer that is no longer reachable.

**DN** --Distinguished Name. A DN is the global, authoritative name of an entry in the Open System Interconnection (OSI Directory [X.500]).

**FQDN** --fully qualified domain name. A FQDN is the full name of a system rather than just its host name. For example, aldebaran is a host name, and aldebaran.interop.com is an FQDN.

**FR** --Frame Relay. FR is an industry-standard, switch-data-link-layer protocol that handles multiple virtual circuits using high-level data link (HDLC) encapsulation between connected devices. Frame Relay is more efficient than X.25, the protocol for which it generally is considered a replacement.

**FVRF** --Front Door Virtual Routing and Forwarding (VRF) repository. FVRF is the VRF used to route the encrypted packets to the peer.

**IDB** --Interface descriptor block. An IDB subblock is an area of memory that is private to an application. This area stores private information and states variables that an application wants to associate with an IDB or an interface. The application uses the IDB to register a pointer to its subblock, not to the contents of the subblock itself.

**IKE** --Internet Key Exchange. IKE establishes a shared security policy and authenticates keys for services (such as IPsec) that require keys. Before any IPsec traffic can be passed, each router, firewall, and host must verify the identity of its peer. This can be done by manually entering preshared keys into both hosts or by a CA service.

**IKE keepalive** --Bidirectional mechanism for determining the liveness of an IKE peer.

**IPsec** --Security protocol for IP.

**IVRF** --Inside Virtual Routing and Forwarding. IVRF is the VRF of the plaintext packets.

**MPLS** --Multiprotocol Label Switching. MPLS is a switching method that forwards IP traffic using a label. This label instructs the routers and the switches in the network where to forward the packets based on preestablished IP routing information.

**RSA** --Rivest, Shamir, and Adelman are the inventors of the RSA technique. The RSA technique is a public-key cryptographic system that can be used for encryption and authentication.

**SA** --Security Association. SA is an instance of security policy and keying material applied to a data flow.

**VPN** --Virtual Private Network. A VPN enables IP traffic to travel securely over a public TCP or IP network by encrypting all traffic from one network to another. A VPN uses “tunneling” to encrypt all information at the IP level.

**VRF** --Virtual Route Forwarding. VRF is A VPN routing and forwarding instance. A VRF consists of an IP routing table, a derived forwarding table, a set of interfaces that use the forwarding table, and a set of rules and routing protocols that determine what goes into the forwarding table. In general, a VRF includes the routing information that defines a customer VPN site that is attached to a PE router.

**XAUTH** --Extended authentication. XAUTH is an optional exchange between IKE Phase 1 and IKE Phase 2, in which the router demands additional authentication information in an attempt to authenticate the actual user (as opposed to authenticating the peer).





## CHAPTER 9

# IKE Initiate Aggressive Mode

The IKE: Initiate Aggressive Mode feature allows you to specify RADIUS tunnel attributes for an IPsec (IPsec) peer and to initiate an Internet Key Exchange (IKE) aggressive mode negotiation with the tunnel attributes. This feature is best implemented in a crypto hub-and-spoke scenario, by which the spokes initiate IKE aggressive mode negotiation with the hub by using the preshared keys that are specified as tunnel attributes and stored on the AAA server. This scenario is scalable because the preshared keys are kept at a central repository (the AAA server) and more than one hub router and one application can use the information.



**Note** Security threats, as well as the cryptographic technologies to help protect against them, are constantly changing. For more information about the latest Cisco cryptographic recommendations, see the [Next Generation Encryption](#) (NGE) white paper.

- [Finding Feature Information, on page 109](#)
- [Prerequisites for IKE Initiate Aggressive Mode, on page 109](#)
- [Restrictions for IKE Initiate Aggressive Mode, on page 110](#)
- [Information About IKE Initiate Aggressive Mode, on page 110](#)
- [How to Configure IKE Initiate Aggressive Mode, on page 111](#)
- [Configuration Examples for IKE Initiate Aggressive Mode, on page 113](#)
- [Additional References, on page 114](#)
- [Feature Information for IKE Initiate Aggressive Mode, on page 115](#)

## Finding Feature Information

Your software release may not support all the features documented in this module. For the latest caveats and feature information, see [Bug Search Tool](#) and the release notes for your platform and software release. To find information about the features documented in this module, and to see a list of the releases in which each feature is supported, see the feature information table.

Use Cisco Feature Navigator to find information about platform support and Cisco software image support. To access Cisco Feature Navigator, go to <https://cfng.cisco.com/>. An account on Cisco.com is not required.

## Prerequisites for IKE Initiate Aggressive Mode

Before configuring the Initiate Aggressive Mode IKE feature, you must perform the following tasks:

- Configure AAA
- Configure an IPsec Transform
- Configure a static crypto map
- Configure an Internet Security Association and Key Management Protocol (ISAKMP) policy
- Configure a dynamic crypto map

## Restrictions for IKE Initiate Aggressive Mode

### TED Restriction

This feature is not intended to be used with a dynamic crypto map that uses Tunnel Endpoint Discovery (TED) to initiate tunnel setup. TED is useful in configuring a full mesh setup, which requires an AAA server at each site to store the preshared keys for the peers; this configuration is not practical for use with this feature.

### Tunnel-Client-Endpoint ID Types

Only the following ID types can be used in this feature:

- ID\_IPV4 (IPv4 address)
- ID\_FQDN (fully qualified domain name, for example “foo.cisco.com”)
- ID\_USER\_FQDN (e-mail address)

## Information About IKE Initiate Aggressive Mode

### Overview

The IKE: Initiate Aggressive Mode feature allows you to configure IKE preshared keys as RADIUS tunnel attributes for IPsec peers. Thus, you can scale your IKE preshared keys in a hub-and-spoke topology.

Although IKE preshared keys are simple to understand and easy to deploy, they do not scale well with an increasing number of users and are therefore prone to security threats. Instead of keeping your preshared keys on the hub router, this feature allows you to scale your preshared keys by storing and retrieving them from an authentication, authorization, and accounting (AAA) server. The preshared keys are stored in the AAA server as Internet Engineering Task Force (IETF) RADIUS tunnel attributes and are retrieved when a user tries to “speak” to the hub router. The hub router retrieves the preshared key from the AAA server and the spokes (the users) initiate aggressive mode to the hub by using the preshared key that is specified in the Internet Security Association Key Management Policy (ISAKMP) peer policy as a RADIUS tunnel attribute.

### RADIUS Tunnel Attributes

To initiate an IKE aggressive mode negotiation, the Tunnel-Client-Endpoint (66) and Tunnel-Password (69) attributes must be configured in the ISAKMP peer policy. The Tunnel-Client-Endpoint attribute will be



communicated to the server by encoding it in the appropriate IKE identity payload; the Tunnel-Password attribute will be used as the IKE preshared key for the aggressive mode negotiation

# How to Configure IKE Initiate Aggressive Mode

## Configuring RADIUS Tunnel Attributes

To configure the Tunnel-Client-Endpoint and Tunnel-Password attributes within the ISAKMP peer configuration, perform the following steps.

### SUMMARY STEPS

1. **enable**
2. **configure terminal**
3. **crypto map** *map-name* **isakmp authorization list** *list-name*
4. **crypto isakmp peer** {*ip-address ip-address* | **fqdn** *fqdn*}
5. **set aggressive-mode client-endpoint** *client-endpoint*
6. **set aggressive-mode password** *password*

### DETAILED STEPS

	Command or Action	Purpose
Step 1	<b>enable</b> <b>Example:</b>  Router> enable	Enables privileged EXEC mode.  • Enter your password if prompted.
Step 2	<b>configure terminal</b> <b>Example:</b>  Router# configure terminal	Enters global configuration mode.
Step 3	<b>crypto map</b> <i>map-name</i> <b>isakmp authorization list</b> <i>list-name</i> <b>Example:</b>  Router (config)# crypto map testmap10 isakmp authorization list list ike	Enables IKE querying of AAA for tunnel attributes in aggressive mode.
Step 4	<b>crypto isakmp peer</b> { <i>ip-address ip-address</i>   <b>fqdn</b> <i>fqdn</i> }	Enables an IPsec peer for IKE querying of AAA for tunnel attributes in aggressive mode and enters ISAKMP policy configuration mode.
Step 5	<b>set aggressive-mode client-endpoint</b> <i>client-endpoint</i> <b>Example:</b>	Specifies the Tunnel-Client-Endpoint attribute within an ISAKMP peer configuration.

	Command or Action	Purpose
	Router (config-isakmp)# set aggressive-mode client-endpoint user-fqdn user@cisco.com	
<b>Step 6</b>	<b>set aggressive-mode password <i>password</i></b> <b>Example:</b> Router (config-isakmp)#set aggressive-mode password cisco123	Specifies the Tunnel-Password attribute within an ISAKMP peer configuration.

## Verifying RADIUS Tunnel Attribute Configurations

To verify that the Tunnel-Client-Endpoint and Tunnel-Password attributes have been configured within the ISAKMP peer policy, use the **show running-config global** configuration command.

## Troubleshooting Tips

To troubleshoot the IKE: Initiate Aggressive Mode feature, perform the following steps.

### SUMMARY STEPS

1. **enable**
2. **debug aaa authorization**
3. **debug crypto isakmp**
4. **debug radius**

### DETAILED STEPS

	Command or Action	Purpose
<b>Step 1</b>	<b>enable</b> <b>Example:</b> Router> enable	Enables privileged EXEC mode. <ul style="list-style-type: none"> <li>• Enter your password if prompted.</li> </ul>
<b>Step 2</b>	<b>debug aaa authorization</b> <b>Example:</b> Router# debug aaa authorization	Displays information about AAA authorization.
<b>Step 3</b>	<b>debug crypto isakmp</b> <b>Example:</b> Router# debug crypto isakmp	Displays messages about IKE events.
<b>Step 4</b>	<b>debug radius</b> <b>Example:</b>	Displays information associated with RADIUS.

	Command or Action	Purpose
	Router# debug radius	

## Configuration Examples for IKE Initiate Aggressive Mode

### Hub Configuration Example

The following example shows how to configure a hub for a hub-and-spoke topology that supports aggressive mode using RADIUS tunnel attributes:

```
!The AAA configurations are as follows:
aaa new-model
aaa authorization network ike group radius
aaa authentication login default group radius
!
! The Radius configurations are as follows:
radius-server host 10.1.1.1 auth-port 1645 acct-port 1646
radius-server key rad123
!
! The IKE configurations are as follows:
crypto isakmp policy 1
 authentication pre-share
!
! The IPsec configurations are as follows:
crypto ipsec transform-set trans1 esp-aes esp-sha-hmac
!
crypto dynamic-map Dmap 10
 set transform-set trans1
!
crypto map Testtag isakmp authorization list ike
crypto map Testtag 10 ipsec-isakmp dynamic Dmap
!
interface FastEthernet0
 ip address 10.4.4.1 255.255.255.0
 crypto map Testtag
!
interface FastEthernet1
 ip address 10.2.2.1 255.255.255.0
```

### Spoke Configuration Example

The following example shows how to configure a spoke for a hub-and-spoke topology that supports aggressive mode using RADIUS tunnel attributes:

```
!The IKE configurations are as follows:
crypto isakmp policy 1
 authentication pre-share
!
! The IPsec configurations are as follows:
crypto ipsec transform-set trans1 esp-aes esp-sha-hmac
 access-list 101 permit ip 10.3.3.0 0.0.0.255 10.2.2.0 0.0.0.255
!
! Initiate aggressive mode using Radius tunnel attributes
```

```

crypto isakmp peer address 10.4.4.1
  set aggressive-mode client-endpoint user-fqdn user@cisco.com
  set aggressive-mode password cisco123
!
crypto map Testtag 10 ipsec-isakmp
  set peer 10.4.4.1
  set transform-set trans1
  match address 101
!
interface FastEthernet0
  ip address 10.5.5.1 255.255.255.0
  crypto map Testtag
!
interface FastEthernet1
  ip address 10.3.3.1 255.255.255.0

```

## RADIUS User Profile Example

The following is an example of a user profile on a RADIUS server that supports the Tunnel-Client-Endpoint and Tunnel-Password attributes:

```

user@cisco.com Password = "cisco", Service-Type = Outbound
  Tunnel-Medium-Type = :1:IP,
  Tunnel-Type = :1:ESP,
  Cisco:Avpair = "ipsec:tunnel-password=cisco123",
  Cisco:Avpair = "ipsec:key-exchange=ike"

```

## Additional References

The following sections provide references related to the IKE: Initiate Aggressive Mode feature.

### Related Documents

Related Topic	Document Title
Security commands	<i>Cisco IOS Security Command Reference</i>
Configuring authentication	Configuring Authentication
Configuring IKE	Configuring Internet Key Exchange for IPsec VPNs
Recommended cryptographic algorithms	<a href="#">Next Generation Encryption</a>

### Standards

Standard	Title
No new or modified standards are supported by this feature, and support for existing standards has not been modified by this feature.	--

**MIBs**

MIB	MIBs Link
No new or modified MIBs are supported by this feature, and support for existing MIBs has not been modified by this feature.	To locate and download MIBs for selected platforms, Cisco IOS XE software releases, and feature sets, use Cisco MIB Locator found at the following URL: <a href="http://www.cisco.com/go/mibs">http://www.cisco.com/go/mibs</a>

**RFCs**

RFC	Title
<ul style="list-style-type: none"> <li>• RFC 2409</li> <li>• RFC 2868</li> </ul>	<ul style="list-style-type: none"> <li>• RFC 2409, <i>The Internet Key Exchange</i></li> <li>• RFC 2868, <i>RADIUS Attributes for Tunnel Protocol Support</i></li> </ul>

**Technical Assistance**

Description	Link
<p>The Cisco Support website provides extensive online resources, including documentation and tools for troubleshooting and resolving technical issues with Cisco products and technologies.</p> <p>To receive security and technical information about your products, you can subscribe to various services, such as the Product Alert Tool (accessed from Field Notices), the Cisco Technical Services Newsletter, and Really Simple Syndication (RSS) Feeds.</p> <p>Access to most tools on the Cisco Support website requires a Cisco.com user ID and password.</p>	<a href="http://www.cisco.com/techsupport">http://www.cisco.com/techsupport</a>

## Feature Information for IKE Initiate Aggressive Mode

The following table provides release information about the feature or features described in this module. This table lists only the software release that introduced support for a given feature in a given software release train. Unless noted otherwise, subsequent releases of that software release train also support that feature.

Use Cisco Feature Navigator to find information about platform support and Cisco software image support. To access Cisco Feature Navigator, go to [www.cisco.com/go/cfn](http://www.cisco.com/go/cfn). An account on Cisco.com is not required.

*Table 6: Feature Information for IKE: Initiate Aggressive Mode*

Feature Name	Releases	Feature Information
IKE: Initiate Aggressive Mode	Cisco IOS XE Release 2.1	<p>The IKE: Initiate Aggressive Mode feature allows you to specify RADIUS tunnel attributes for an IPsec peer and to initiate an IKE aggressive mode negotiation with the tunnel attributes.</p> <p>The following commands were introduced or modified: <b>crypto isakmp peer</b>, <b>set aggressive-mode client-endpoint</b>, <b>set aggressive-mode password</b>.</p>